

E22703

First Edition / February 2024

IN SEARCH OF INCREDIBLE



Service Manual

ASUS

COPYRIGHT INFORMATION

No part of this manual, including the products and software described in it, may be reproduced, transmitted, transcribed, stored in a retrieval system, or translated into any language in any form or by any means, except documentation kept by the purchaser for backup purposes, without the express written permission of ASUSTeK COMPUTER INC. ("ASUS").

ASUS PROVIDES THIS MANUAL "AS IS" WITHOUT WARRANTY OF ANY KIND, EITHER EXPRESS OR IMPLIED, INCLUDING BUT NOT LIMITED TO THE IMPLIED WARRANTIES OR CONDITIONS OF MERCHANTABILITY OR FITNESS FOR A PARTICULAR PURPOSE. IN NO EVENT SHALL ASUS, ITS DIRECTORS, OFFICERS, EMPLOYEES OR AGENTS BE LIABLE FOR ANY INDIRECT, SPECIAL, INCIDENTAL, OR CONSEQUENTIAL DAMAGES (INCLUDING DAMAGES FOR LOSS OF PROFITS, LOSS OF BUSINESS, LOSS OF USE OR DATA, INTERRUPTION OF BUSINESS AND THE LIKE), EVEN IF ASUS HAS BEEN ADVISED OF THE POSSIBILITY OF SUCH DAMAGES ARISING FROM ANY DEFECT OR ERROR IN THIS MANUAL OR PRODUCT.

Products and corporate names appearing in this manual may or may not be registered trademarks or copyrights of their respective companies, and are used only for identification or explanation and to the owners' benefit, without intent to infringe.

SPECIFICATIONS AND INFORMATION CONTAINED IN THIS MANUAL ARE FURNISHED FOR INFORMATIONAL USE ONLY, AND ARE SUBJECT TO CHANGE AT ANY TIME WITHOUT NOTICE, AND SHOULD NOT BE CONSTRUED AS A COMMITMENT BY ASUS. ASUS ASSUMES NO RESPONSIBILITY OR LIABILITY FOR ANY ERRORS OR INACCURACIES THAT MAY APPEAR IN THIS MANUAL, INCLUDING THE PRODUCTS AND SOFTWARE DESCRIBED IN IT.

Copyright © 2024 ASUSTeK COMPUTER INC. All Rights Reserved.

LIMITATION OF LIABILITY

Circumstances may arise where because of a default on ASUS' part or other liability, you are entitled to recover damages from ASUS. In each such instance, regardless of the basis on which you are entitled to claim damages from ASUS, ASUS is liable for no more than damages for bodily injury (including death) and damage to real property and tangible personal property; or any other actual and direct damages resulted from omission or failure of performing legal duties under this Warranty Statement, up to the listed contract price of each product.

ASUS will only be responsible for or indemnify you for loss, damages or claims based in contract, tort or infringement under this Warranty Statement.

This limit also applies to ASUS' suppliers and its reseller. It is the maximum for which ASUS, its suppliers, and your reseller are collectively responsible.

UNDER NO CIRCUMSTANCES IS ASUS LIABLE FOR ANY OF THE FOLLOWING: (1) THIRD-PARTY CLAIMS AGAINST YOU FOR DAMAGES; (2) LOSS OF, OR DAMAGE TO, YOUR RECORDS OR DATA; OR (3) SPECIAL, INCIDENTAL, OR INDIRECT DAMAGES OR FOR ANY ECONOMIC CONSEQUENTIAL DAMAGES (INCLUDING LOST PROFITS OR SAVINGS), EVEN IF ASUS, ITS SUPPLIERS OR YOUR RESELLER IS INFORMED OF THEIR POSSIBILITY.

SERVICE AND SUPPORT

Visit our multi-language website at <https://www.asus.com/support/>

Table of Contents

Chapter 1: Introduction

Disclaimer	8
Safety precautions.....	8
Pre-repair checklist	10
Installation tools.....	11
Accessories.....	11
Diagnostic tools	11
Major components.....	12

Chapter 2: Service Procedures

Bottom cover.....	20
Removal	21
Installation	23
Battery	25
Removal	26
Installation	29
M.2 SSD module.....	32
Removal	33
Installation	35
WLAN module.....	38
Removal	39
Installation	40
LTE module (on selected models).....	41
Removal	42
Installation	43

RAM module.....	44
Removal	45
Installation	46
Speakers.....	48
Removal	49
Installation	50
Heat sink	51
Removal	52
Installation	54
Fan module	56
Removal	57
Installation	58
Smart card reader (on selected models)	59
Removal	60
Installation	61
Display panel module.....	62
Removal	63
Installation	67
I/O board.....	71
Removal	72
Installation	73
Motherboard	74
Removal	75
Installation	77

Touchpad.....	80
Removal	81
Installation	83
Keyboard module.....	85
Removal	86
Installation	87

Appendix

Wiring and connection diagrams	90
--------------------------------------	----

Chapter 1: ***Introduction***

Disclaimer

ASUS is not responsible for direct, indirect, intentional or unintentional damages resulting from improper installation and operation.

Safety precautions

- Before handling components, use a grounded wrist strap or touch a safely grounded object to avoid damaging them due to static electricity.
- Keep liquids or moisture away from your device to avoid short circuits.
- Remove rings, watches, and any other metal objects from your hands.
- Hold components by the edges to avoid touching the ICs.
- Properly install all components before connecting the AC power.
- Do not use power adapters or batteries from other devices to reduce the risk of injury to persons due to fire or explosion. Use only certified power adapters or batteries supplied by the manufacturer or authorized retailers.
- Detach all clips or flaps before removing cables to prevent damage.

- Disconnect cables, connectors, and power plugs by pulling the plug evenly to avoid damage.
- Use the correct screw models on your device to prevent damage.
- Confirm that the cable orientation is correct before connecting any cables.
- Fully remove all adhesive residue after removing and before installing any components.
- Photograph the appearance of cables, cable routing, connectors, and screws for later reference before proceeding with each step.

Pre-repair checklist

- Read the entire manual before starting any service procedures and follow all instructions.
 - Back up the data on your device.
 - Place your device on a clean and stable surface.
 - Turn off your device.
 - Disconnect all connected peripherals and cables.
 - Disconnect all power cables and remove the battery pack (if applicable).
-

IMPORTANT!

- If you are uncertain about performing the described service procedures, stop and contact an authorized service center for assistance.
 - Purchase replacement components from authorized retailers of this device to ensure maximum compatibility and reliability.
-

NOTE:

- The illustrations are for reference only.
 - The service procedures described in this manual depend on the model configuration and may not reflect the entire servicing process. To service components that are not covered in this manual, please visit an authorized service center for further assistance.
 - Keep all adhesive tape, insulating materials, screws, and other removable items in a safe place until the service procedure is completed, as they may be needed during installation.
-

Installation tools



Screwdriver



Plastic blade



Tweezers

Accessories



Power adapter

Diagnostic tools

Use ASUS System Diagnostics after completing any service procedures to ensure that all components are working properly.

For more information, visit www.asus.com/support/FAQ/1048490/.

Major components

B5404CVA

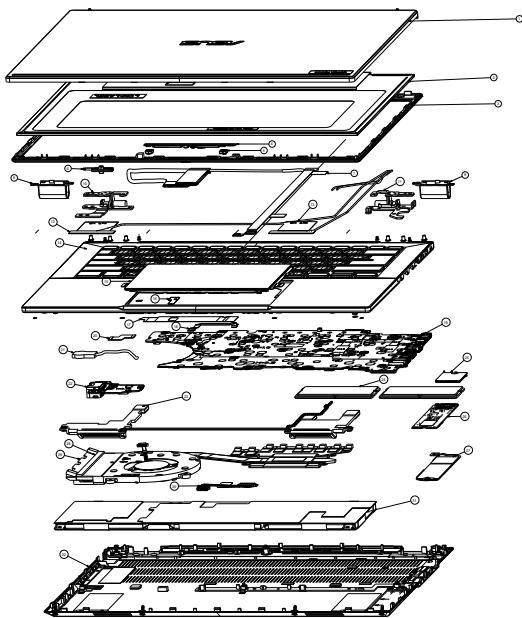

1. Top cover
2. Display panel
3. Display bezel
4. Camera module
5. Microphone rubber caps
6. Webcam shield
7. eDP cable
8. Hinge cap (left)
9. Hinge cap (right)
10. Hinge (left)
11. Hinge (right)
12. Auxiliary antenna cable
13. Main antenna cable
14. Keyboard module
15. Touchpad
16. Touchpad tape
17. Touchpad polyester film
18. Touchpad cable
19. Motherboard
20. I/O board cable
21. Coin battery
22. I/O board
23. Speakers
24. RAM module
25. WLAN module
26. M.2 SSD module
27. M.2 SSD bracket
28. Fan
29. Heat sink
30. Battery power cable
31. Battery
32. Bottom cover

1. Top cover
2. Display panel
3. Display bezel
4. Camera module
5. Microphone rubber caps
6. Webcam shield
7. eDP cable
8. Hinge cap (left)
9. Hinge cap (right)
10. Hinge (left)
11. Hinge (right)
12. Auxiliary antenna cable
13. Main antenna cable
14. Keyboard module
15. Touchpad
16. Touchpad tape
17. Touchpad polyester film
18. Touchpad cable
19. Motherboard
20. I/O board cable
21. Coin battery
22. I/O board
23. Speakers
24. RAM module
25. WLAN module
26. M.2 SSD module
27. M.2 SSD bracket
28. Fan
29. Heat sink
30. Battery power cable
31. Battery
32. Bottom cover

B5404CMA

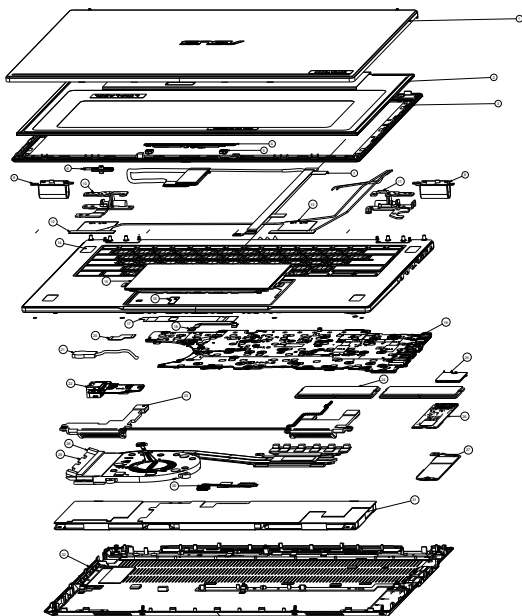

1. Top cover
2. Display panel
3. Display bezel
4. Camera module
5. Microphone rubber caps
6. Webcam shield
7. eDP cable
8. Hinge cap (left)
9. Hinge cap (right)
10. Hinge (left)
11. Hinge (right)
12. Auxiliary antenna cable
13. Main antenna cable
14. Keyboard module
15. Touchpad
16. Touchpad tape
17. Touchpad polyester film
18. Touchpad cable
19. Motherboard
20. I/O board cable
21. Coin battery
22. I/O board
23. Speakers
24. RAM module
25. WLAN module
26. M.2 SSD module
27. M.2 SSD bracket
28. Fan
29. Heat sink
30. Battery power cable
31. Battery
32. Bottom cover

Chapter 2: ***Service Procedures***

Bottom cover

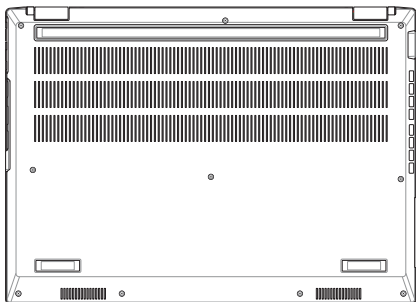

Before you begin

Read the **Safety Precautions** and complete the **Pre-repair Checklist**.

Screw list

- ⊕ M2.0 X 8.5L (3-6pcs)
- ⊕ M2.0 X 6.5L (4-7pcs)

Removal

1. Remove the screw(s) from the bottom cover.

B5404CVF

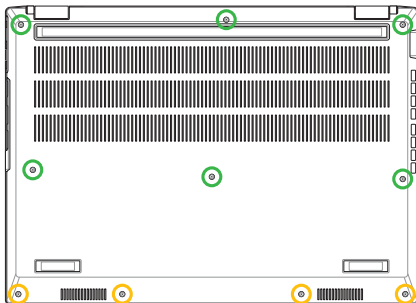

B5404CVA/B5404CMA

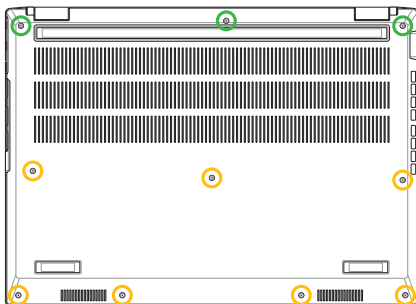

2. Use the plastic blade to pry open the indicated area of the bottom cover as shown in the illustration below.

IMPORTANT! Avoid sliding the plastic blade along the side of your device or air vents to prevent damage.

3. Remove the bottom cover.

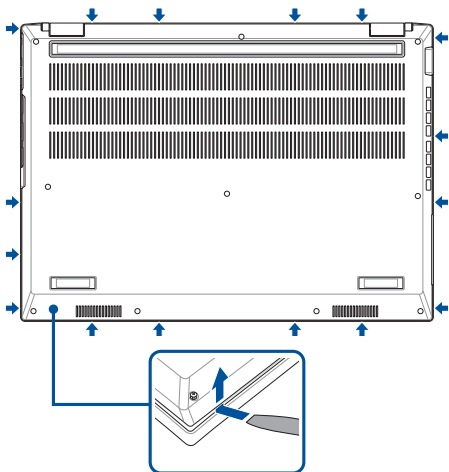

Installation

1. Install the bottom cover.
2. Gently press down on the bottom cover until it clicks into place.

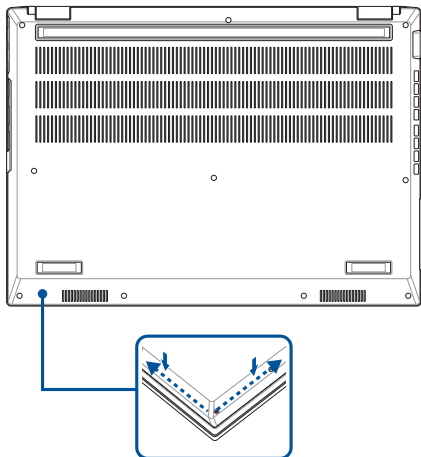

3. Secure the bottom cover using the screw(s) you removed earlier.

B5404CVF

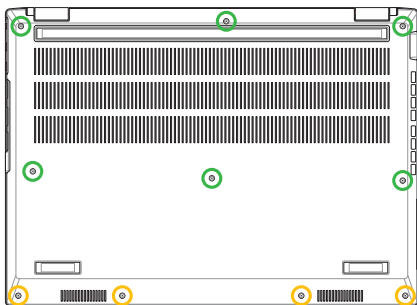

B5404CVA/B5404CMA

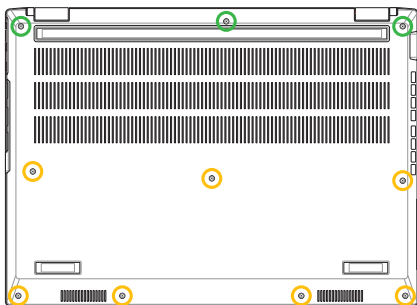

Battery

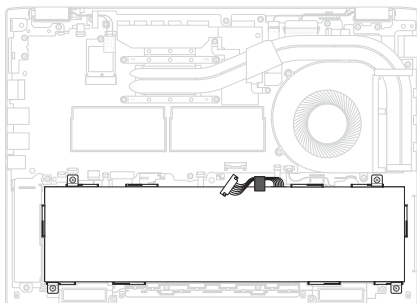

Before you begin

1. Read the **Safety Precautions** and **Pre-repair Checklist**.
2. Remove the following components:
 - Bottom cover

Screw list

- ⊕ M2.0 X 4.0L (4pcs)

Removal

1. Remove the tape, then disconnect the battery power cable.

IMPORTANT!

- Disconnect the battery power cable by lifting the side with the red wires first.
 - Serious risk of fire or explosion may occur if the battery is punctured. If you are uncertain about proceeding, stop and contact an authorized service center for assistance.
-

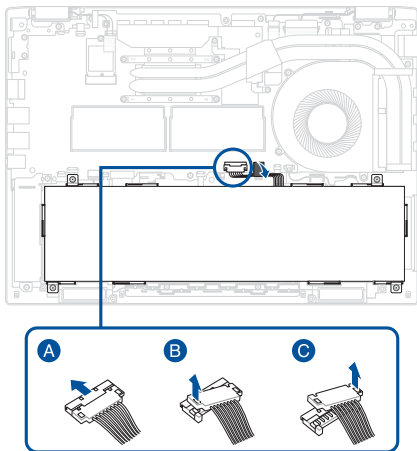

2. Remove the screw(s) from the battery, then remove the battery.

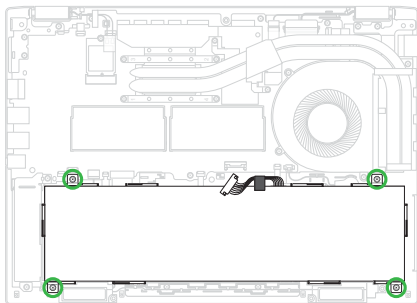

3. Remove the battery power cable.

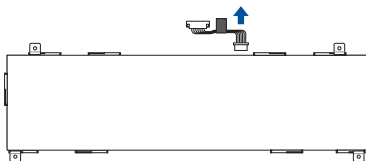

4. Remove the battery brackets from the battery.

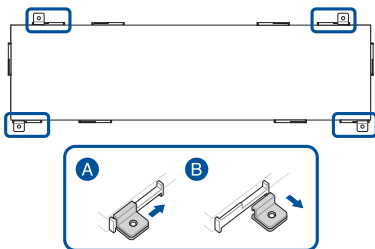

Installation

1. Attach the battery brackets to the battery.

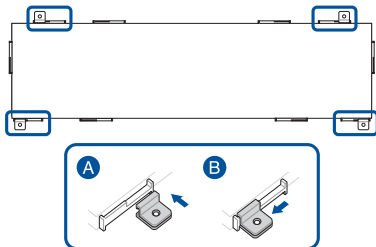

2. Connect the battery power cable to the battery.

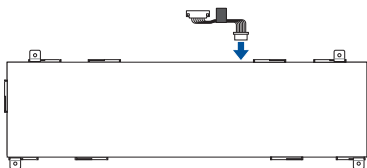

3. Attach the polyester film to the battery.

NOTE: This step is only required when you are replacing the existing component with a new one.

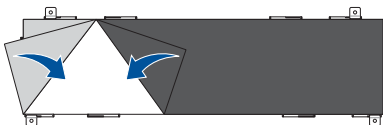

4. Install the battery, then secure the battery using the screw(s) you removed earlier.

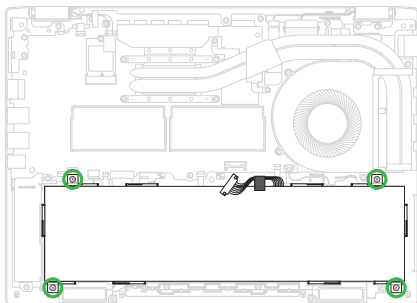

5. Reconnect the battery power cable, then reattach the tape.
6. Install the components you removed in the *Before you begin* section.

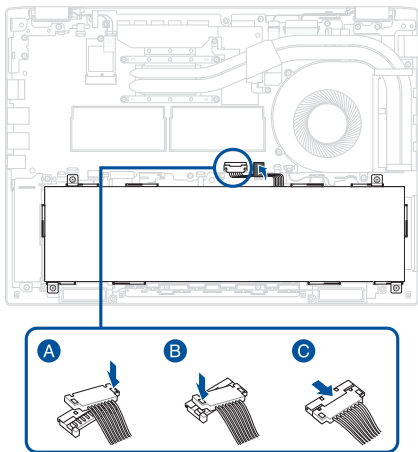

M.2 SSD module

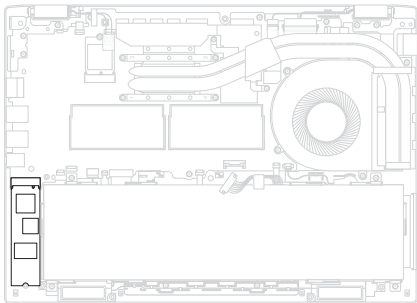

Before you begin

1. Read the **Safety Precautions** and **Pre-repair Checklist**.
2. Remove the following components:
 - Bottom cover
 - Battery

Screw list

- ⊕ M2.0 X 4.0L (2pcs)
- ⊕ M2.0 X 3.0L (2pcs)

Removal

M.2 2280 SSD module

1. Remove the screw(s), then remove the M.2 SSD shield.

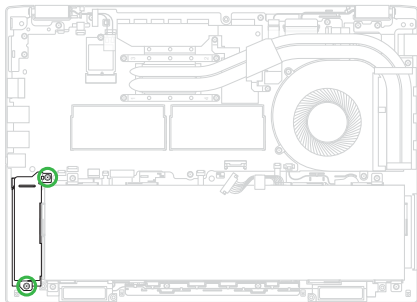

2. Remove the M.2 SSD module from the motherboard.

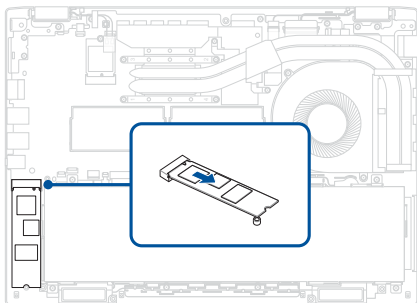

M.2 2230 SSD module (on selected models)

1. Remove the screw, then remove the M.2 SSD module from the motherboard.
2. Flip the M.2 SSD module over, then remove the screw and remove the M.2 SSD module from the M.2 SSD bracket.
3. Install the M.2 SSD bracket, then secure the M.2 SSD bracket using the screw you removed earlier.

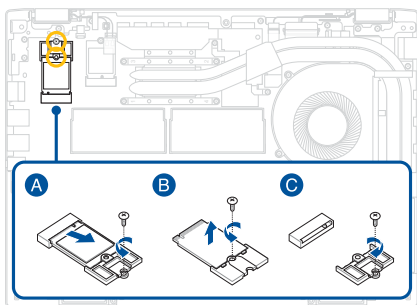

Installation

M.2 2280 SSD module

1. Align and insert the M.2 SSD module into the M.2 connector on the motherboard.

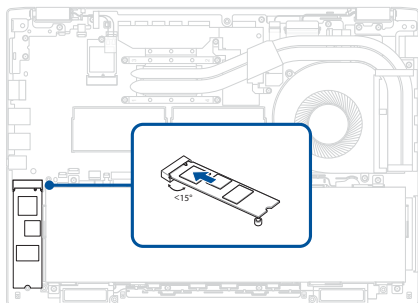

2. Install the M.2 SSD shield, then secure the M.2 SSD shield using the screw(s) you removed earlier.
3. Install the components you removed in the *Before you begin* section.

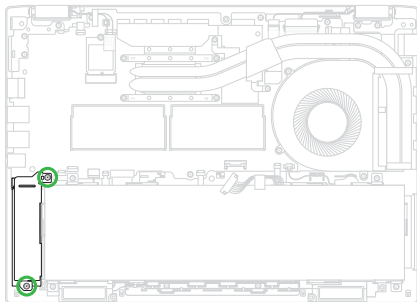

M.2 2230 SSD module (on selected models)

1. Remove the screw, then remove the M.2 SSD bracket from the motherboard.
2. Flip the M.2 SSD bracket over, then secure the M.2 SSD module to the M.2 SSD bracket using the screw you removed earlier.
3. Align and insert the M.2 SSD module into the M.2 connector on the motherboard, then secure the M.2 SSD module using the screw you removed earlier.
4. Install the components you removed in the *Before you begin* section.

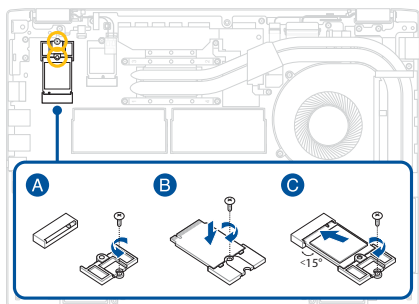

WLAN module

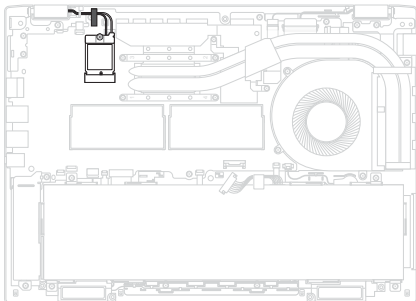

Before you begin

1. Read the **Safety Precautions** and **Pre-repair Checklist**.
2. Remove the following components:
 - Bottom cover
 - Battery

Screw list

- ⊕ M2.0 X 3.0L (1pc)

Removal

1. Remove the screw and remove the bracket, then disconnect the cable(s) and remove the WLAN module.
2. Remove the tape, then remove the cable(s) from the cable guide(s).

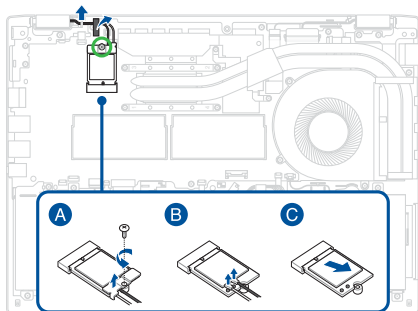

Installation

1. Install the WLAN module and reconnect the cable(s), then install the bracket and secure the bracket using the screw you removed earlier.
2. Route the cable(s) through the cable guide(s), then reattach the tape.

IMPORTANT! Damage may occur if cables are not properly routed through the cable guides. Confirm that all cables are routed through each of the indicated cable guides before proceeding.

3. Install the components you removed in the *Before you begin* section.

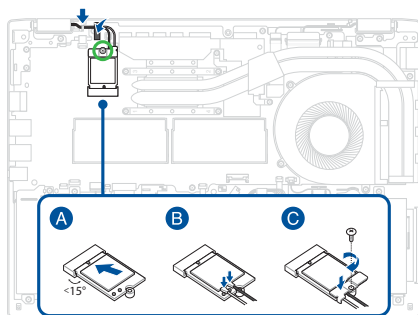

LTE module (on selected models)

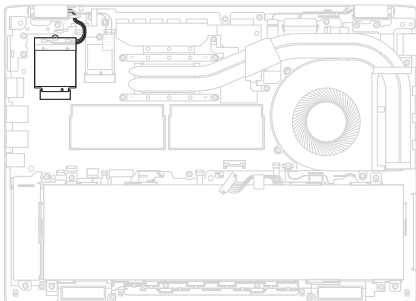

Before you begin

1. Read the **Safety Precautions** and **Pre-repair Checklist**.
2. Remove the following components:
 - Bottom cover
 - Battery

Screw list

- ⊕ M2.0 X 3.0L (1pc)

Removal

1. Remove the polyester film and disconnect the cable(s), then remove the screw and remove the LTE module.
2. Remove the cable from the cable guide.

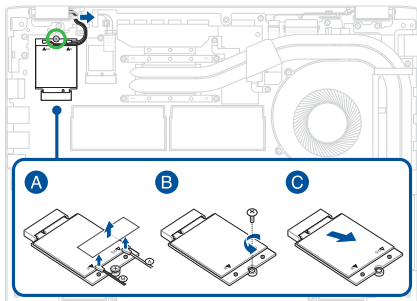

Installation

1. Install the LTE module and secure the LTE module using the screw you removed earlier, then reconnect the cable(s) and reattach the polyester film.
2. Route the cable through the cable guide(s).

IMPORTANT! Damage may occur if cables are not properly routed through the cable guides. Confirm that all cables are routed through each of the indicated cable guides before proceeding.

3. Install the components you removed in the *Before you begin* section.

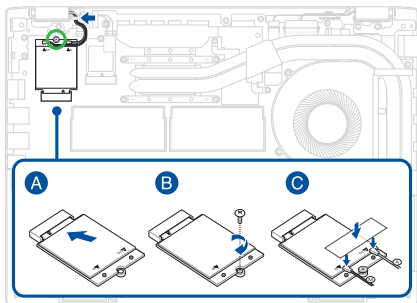

RAM module

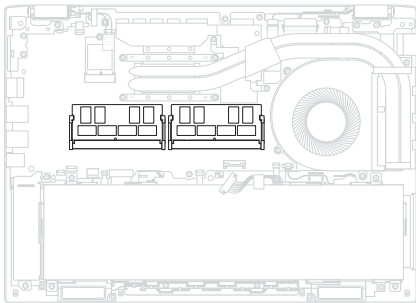

Before you begin

1. Read the **Safety Precautions** and **Pre-repair Checklist**.
2. Remove the following components:
 - Bottom cover
 - Battery

Removal

1. Remove the polyester film.

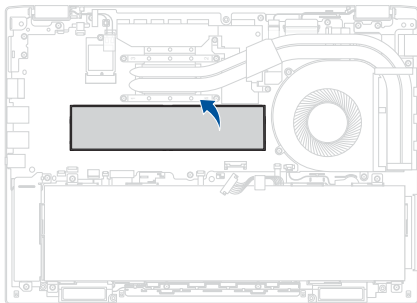

2. Push the clips outwards to remove the RAM module.

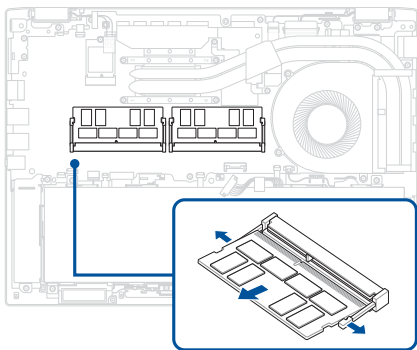

Installation

1. Align and insert the RAM module into the RAM module slot.

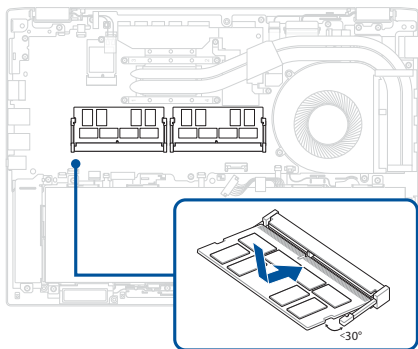

2. Reattach the polyester film.
3. Install the components you removed in the *Before you begin* section.

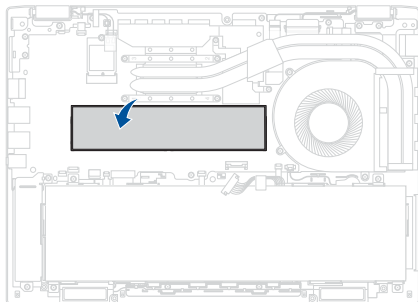

Speakers

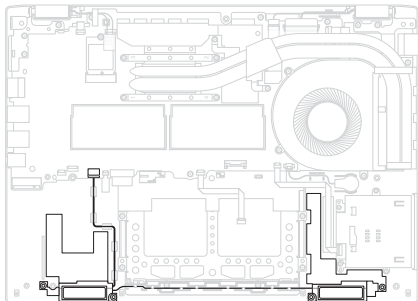

Before you begin

1. Read the **Safety Precautions** and **Pre-repair Checklist**.
2. Remove the following components:
 - Bottom cover
 - Battery

Removal

1. Disconnect the speaker connector.
2. Remove the cable from the cable guide(s).
3. Remove the speakers.

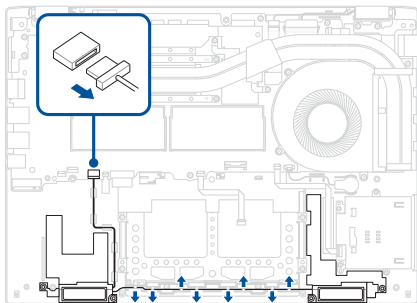

Installation

1. Install the speakers.
2. Route the cable through the cable guide(s).

IMPORTANT! Damage may occur if cables are not properly routed through the cable guides. Confirm that all cables are routed through each of the indicated cable guides before proceeding.

3. Reconnect the speaker connector.
4. Install the components you removed in the *Before you begin* section.

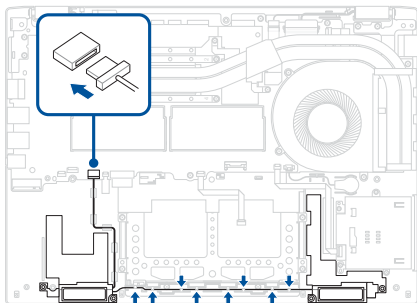

Heat sink

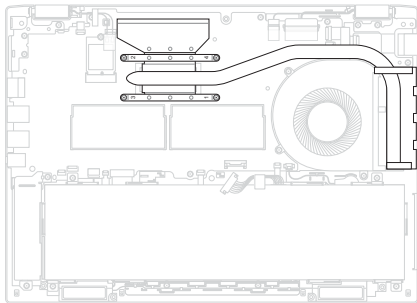

Before you begin

IMPORTANT! Thermal paste, thermal pads, liquid metal, or other thermal interface materials must be thoroughly removed and replaced if this component is removed. Ensure that replacement materials are available before proceeding, or contact an authorized service center for assistance.

1. Read the **Safety Precautions** and **Pre-repair Checklist**.
2. Remove the following components:
 - Bottom cover
 - Battery

Screw list

- ⊕ M2.0 X 3.0L (4-6pcs)

Removal

Remove the heat sink screw(s) one by one in the sequence shown in the illustration below, then remove the heat sink.

IMPORTANT! Vertically lift the heat sink using the left side of the heat sink to prevent damage.

4-screw heat sink

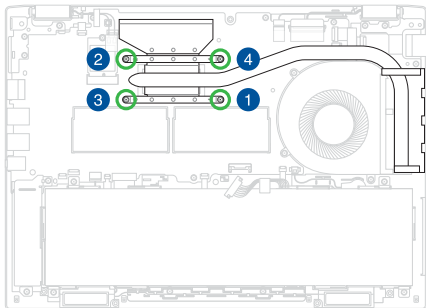

6-screw heat sink

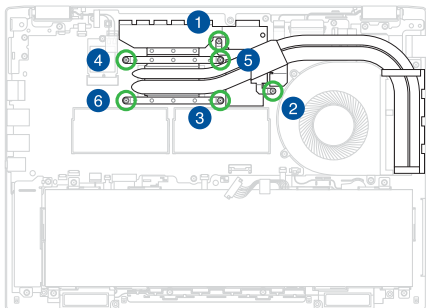

Installation

1. Install the heat sink, then secure the heat sink screw(s) one by one in the sequence shown in the illustration below.
2. Install the components you removed in the *Before you begin* section.

4-screw heat sink

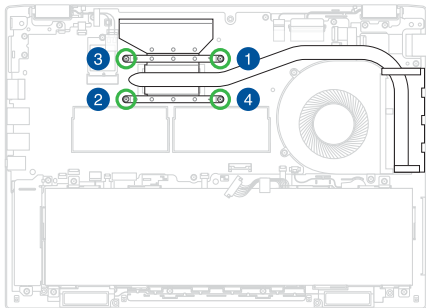

6-screw heat sink

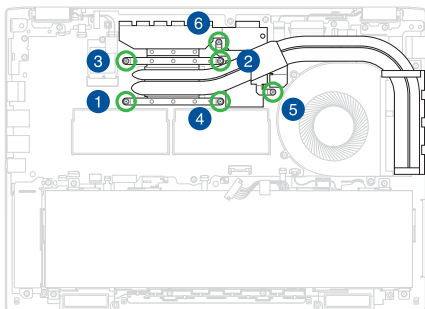

Fan module

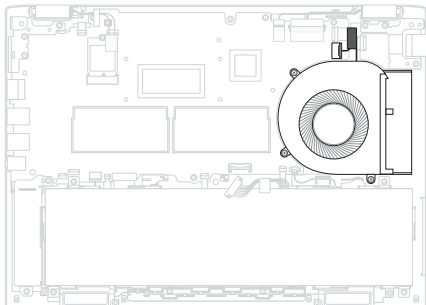

Before you begin

1. Read the **Safety Precautions** and **Pre-repair Checklist**.
2. Remove the following components:
 - Bottom cover
 - Battery
 - Heat sink

Screw list

- ⊕ M2.0 X 4.0L (3pcs)

Removal

1. Remove the tape, then disconnect the fan connector.
2. Remove the screw(s).
3. Remove the fan.

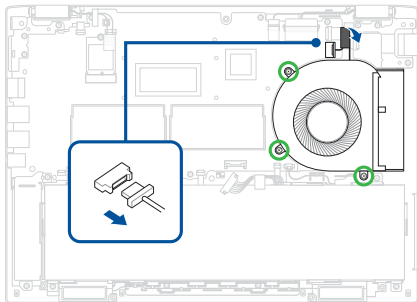

Installation

1. Install the fan.
2. Secure the fan using the screw(s) you removed earlier.
3. Reconnect the fan connector, then reattach the tape.
4. Install the components you removed in the *Before you begin* section.

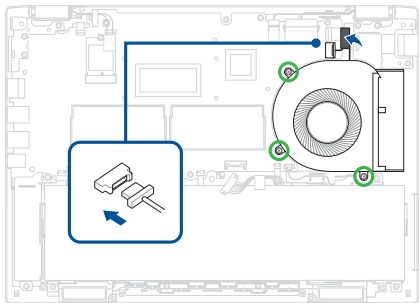

Smart card reader (on selected models)

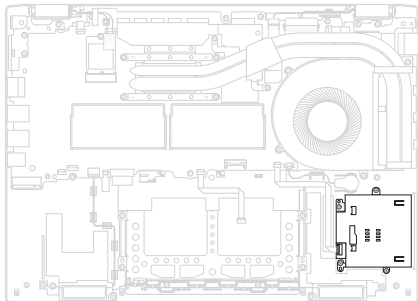

Before you begin

1. Read the **Safety Precautions** and **Pre-repair Checklist**.
2. Remove the following components:
 - Bottom cover
 - Battery

Screw list

- ⊕ M1.6 X 2.0L (4pcs)

Removal

Disconnect the cable and remove the screw(s), then remove the smart card reader.

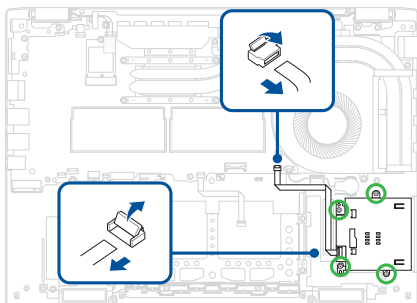

Installation

1. Install the smart card reader, then secure the smart card reader using the screw(s) you removed earlier and reconnect the cable.
2. Install the components you removed in the *Before you begin* section.

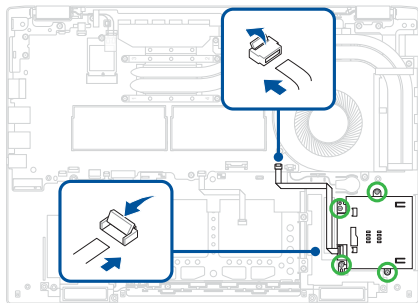

Display panel module

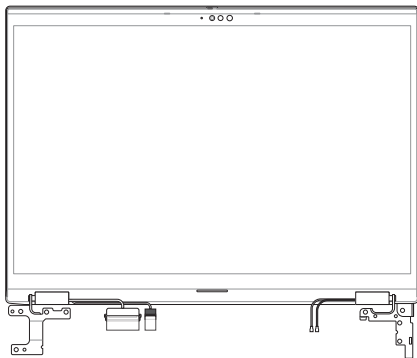

Before you begin

IMPORTANT! Do not bend the display panel in any way to avoid risk of display panel leakage.

1. Read the **Safety Precautions** and **Pre-repair Checklist**.
2. Remove the following components:
 - Bottom cover
 - Battery

Screw list

- ⊕ M2.5 X 4.5L (6pcs)

Removal

1. Place your device with the display panel hanging over the edge of the workspace as shown in the illustration below.

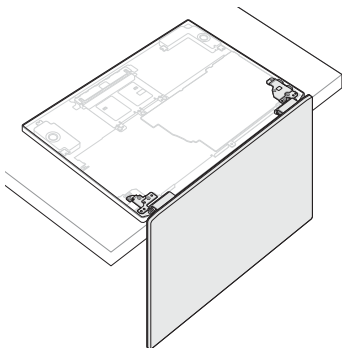

2. Remove the screw and remove the bracket, then disconnect the cable(s).
3. Remove the tape, then remove the cable(s) from the cable guide(s).

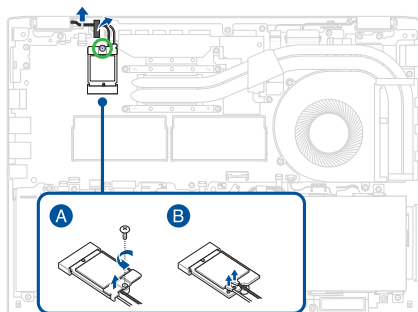

4. Remove the polyester film and disconnect the cable(s) (if available).
5. Remove the cable(s) from the cable guide(s) (if available).

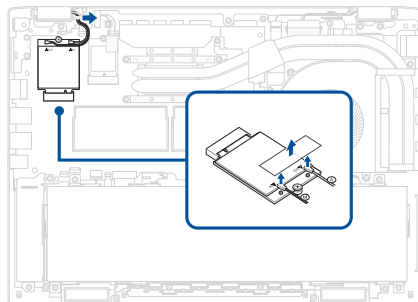

6. Disconnect the cable(s).
7. Remove the cable(s) from the cable guide(s).
8. Remove the screw(s).

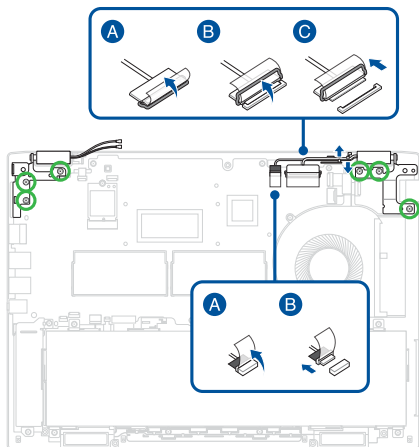

9. Remove the display panel module.

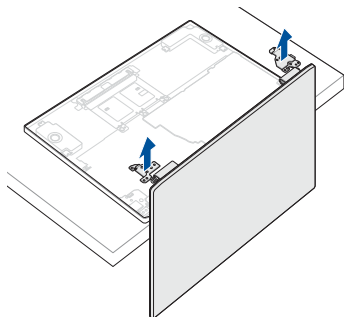

Installation

1. In the orientation shown, align and place the hinges of the display panel module on the screw holes.

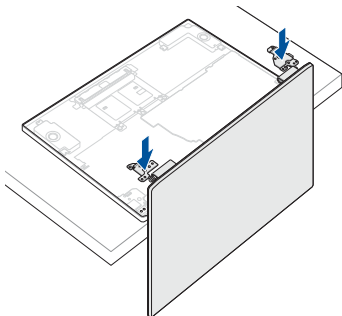

2. Secure the hinges using the screw(s) you removed earlier.
3. Route the cable(s) through the cable guide(s).

IMPORTANT! Damage may occur if cables are not properly routed through the cable guides. Confirm that all cables are routed through each of the indicated cable guides before proceeding.

4. Reconnect the cable(s).

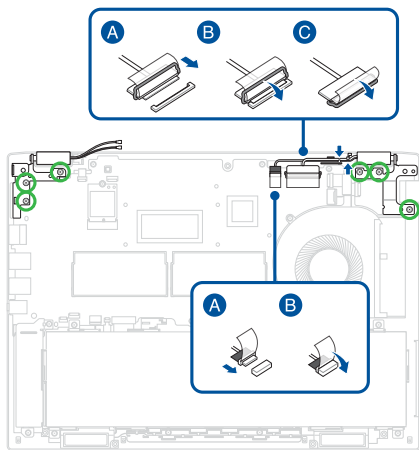

5. Reconnect the cable(s) and reattach the polyester film (if available).
6. Route the cable through the cable guide(s) (if available).

IMPORTANT! Damage may occur if cables are not properly routed through the cable guides. Confirm that all cables are routed through each of the indicated cable guides before proceeding.

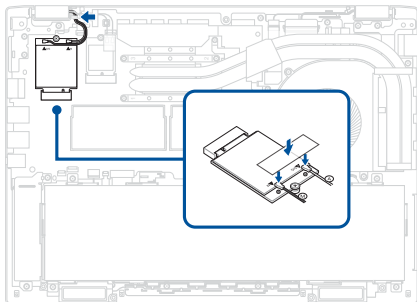

7. Reconnect the cable(s), then install the bracket and secure the bracket using the screw you removed earlier.
8. Route the cable(s) through the cable guide(s), then reattach the tape.

IMPORTANT! Damage may occur if cables are not properly routed through the cable guides. Confirm that all cables are routed through each of the indicated cable guides before proceeding.

9. Install the components you removed in the *Before you begin* section.

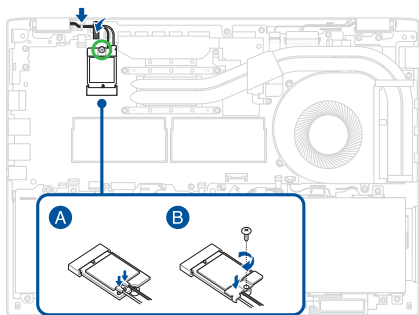

I/O board

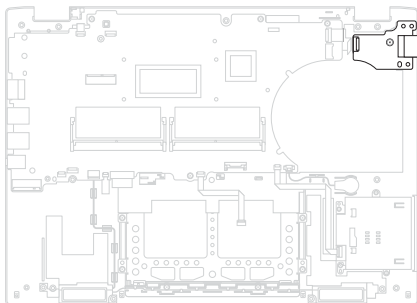

Before you begin

1. Read the **Safety Precautions** and **Pre-repair Checklist**.
2. Remove the following components:
 - Bottom cover
 - Battery
 - Heat sink
 - Fan module
 - Display panel module

Screw list

- ⊕ M2.0 X 2.0L (1pc)

Removal

Remove the screw and disconnect the cable, then remove the I/O board.

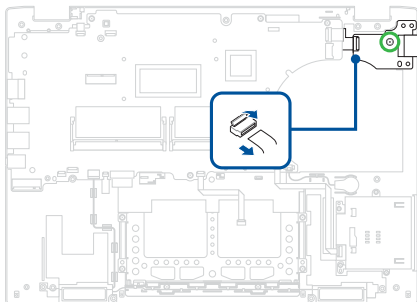

Installation

1. Install the I/O board, then reconnect the cable and secure the I/O board using the screw you removed earlier.
2. Install the components you removed in the *Before you begin* section.

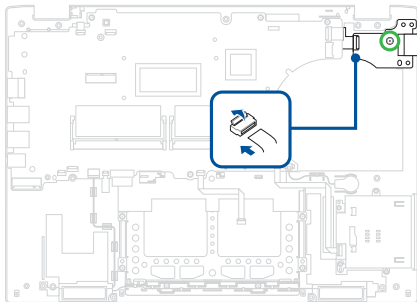

Motherboard

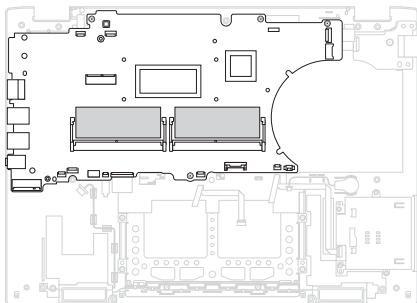

Before you begin

1. Read the **Safety Precautions** and **Pre-repair Checklist**.
2. Remove the following components:
 - Bottom cover
 - Battery
 - M.2 SSD module
 - WLAN module
 - LTE module (on selected models)
 - Heat sink
 - Fan module
 - Display panel module

Screw list

- ⊕ M2.0 X 4.0L (4pcs)

Removal

1. Remove the tape, then disconnect the cable(s) from the motherboard.

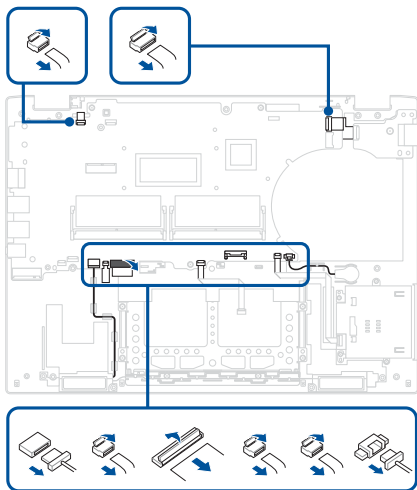

2. Remove the screw(s), then remove the motherboard from the chassis.

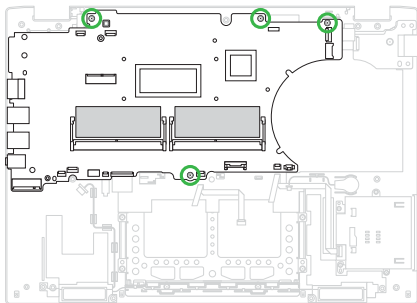

Installation

1. Attach the polyester film to the bottom of the motherboard.

NOTE: This step is only required when you are replacing the existing component with a new one.

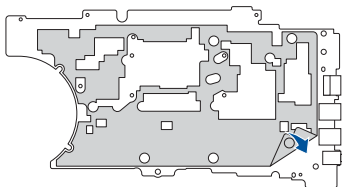

2. Flip the motherboard over, then attach the polyester film to the top of the motherboard.

NOTE: This step is only required when you are replacing the existing component with a new one.

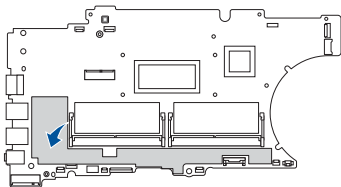

3. Align and install the motherboard, then secure the motherboard using the screw(s) you removed earlier.

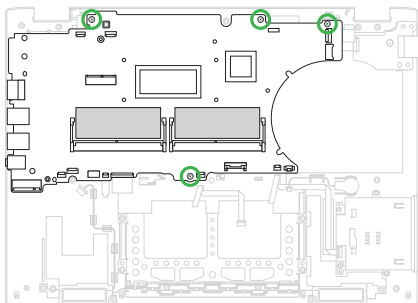

4. Reconnect the cable(s) to the motherboard, then reattach the tape.
5. Install the components you removed in the *Before you begin* section.

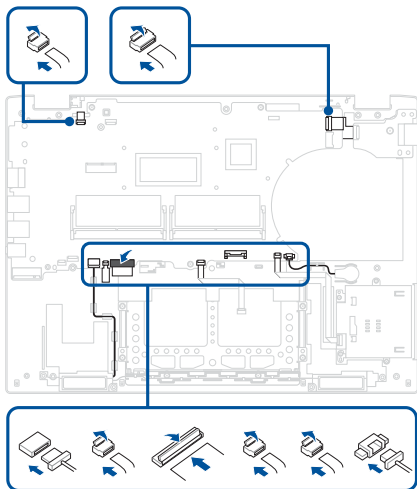

Touchpad

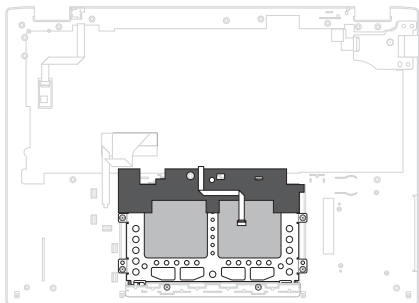

Before you begin

1. Read the **Safety Precautions** and **Pre-repair Checklist**.
2. Remove the following components:
 - Bottom cover
 - Battery
 - M.2 SSD module
 - WLAN module
 - LTE module (on selected models)
 - Heat sink
 - Fan module

- Smart card reader (on selected models)
- Display panel module
- Motherboard

Screw list

- ⊕ M2.0 X 2.5L (8pcs)

Removal

1. Disconnect the cable, then remove the polyester film.

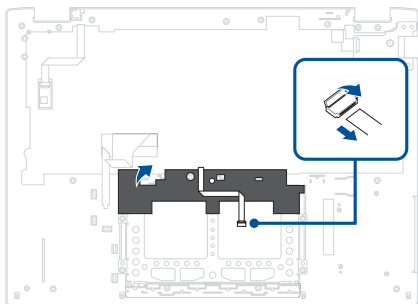

2. Remove the screw(s), then remove the touchpad.

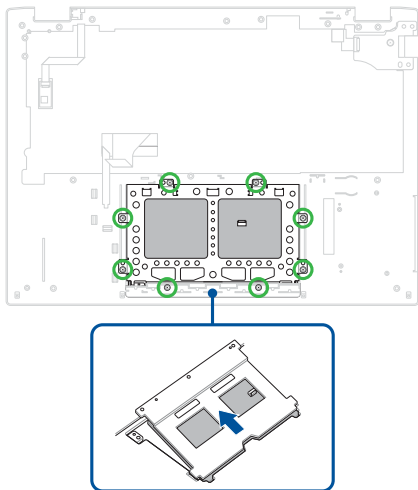

Installation

1. Install the touchpad, then secure the touchpad using the screw(s) you removed earlier.

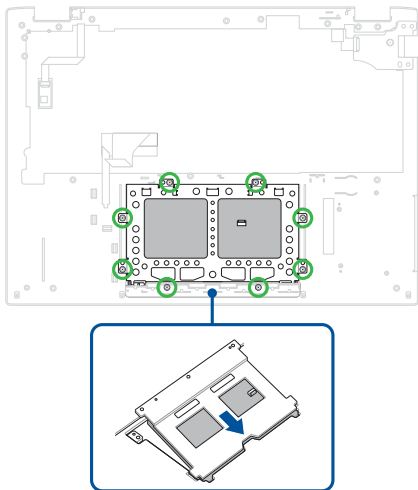

2. Reattach the polyester film, then reconnect the cable.
3. Install the components you removed in the *Before you begin* section.

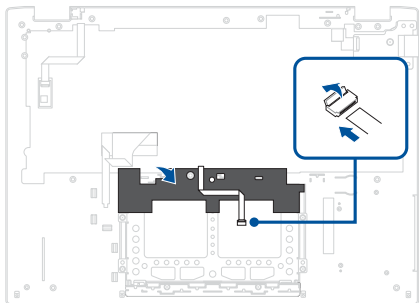

Keyboard module

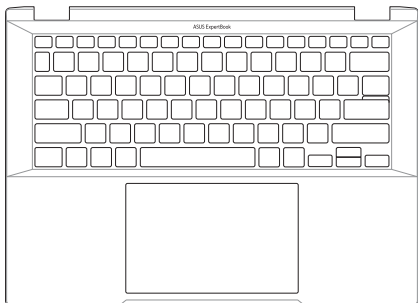

Before you begin

1. Read the **Safety Precautions** and **Pre-repair Checklist**.
2. Remove the following components:
 - Bottom cover
 - Battery
 - M.2 SSD module
 - WLAN module
 - LTE module (on selected models)
 - Speakers
 - Heat sink
 - Fan module

- Smart card reader (on selected models)
- Display panel module
- Motherboard
- Touchpad

Removal

Disconnect the cable, then remove the coin battery.

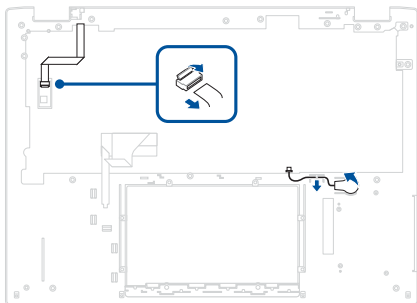

Installation

1. Install the coin battery and reconnect the cable.
2. Route the cable(s) through the cable guide(s).

IMPORTANT! Damage may occur if cables are not properly routed through the cable guides. Confirm that all cables are routed through each of the indicated cable guides before proceeding.

3. Install the components you removed in the *Before you begin* section.

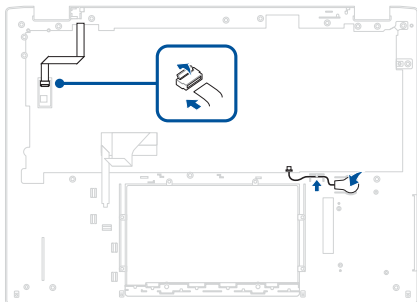



Appendix

Wiring and connection diagrams

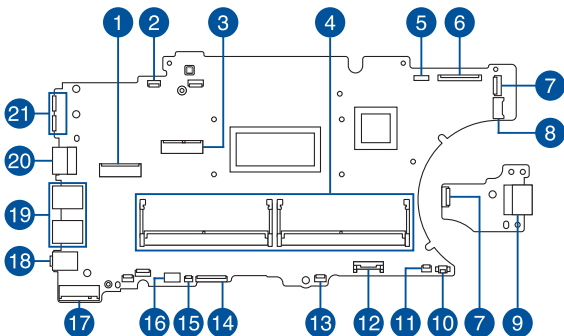

- | | |
|----------------------------------|-----------------------------------|
| 1. LTE module connector* | 12. Battery connector |
| 2. Fingerprint sensor connector | 13. Touchpad connector |
| 3. WLAN module connector | 14. Keyboard connector |
| 4. RAM module slot | 15. Keyboard backlight connector* |
| 5. Touch panel connector* | 16. Speaker connector |
| 6. eDP connector | 17. M.2 SSD connector |
| 7. I/O board connector | 18. Audio connector |
| 8. Fan connector | 19. USB Type-A connector |
| 9. LAN connector | 20. HDMI connector |
| 10. Coin battery connector | 21. USB Type-C® connector |
| 11. Smart card reader connector* | |

* On selected models