



Product Overview

- [Switch Models, on page 1](#)
- [Front Panel Components, on page 3](#)
- [Rear Panel, on page 8](#)
- [Network Configurations, on page 13](#)

Switch Models

The Cisco Catalyst 9200 Series switches have modular (C9200) and fixed (C9200L) switch models. The following tables describe all the available Cisco Catalyst 9200 Series switches and the features supported.

Table 1: C9200L Switch Models and Descriptions

Switch Model	Description
C9200L-24P-4G	Stackable 24x1G PoE+ ports; 4x1G SFP fixed uplink ports; 2 power supply slots; 2 fixed fans; supports StackWise-80.
C9200L-24P-4X	Stackable 24x1G PoE+ ports; 4x10G SFP+ fixed uplink ports; 2 power supply slots; 2 fixed fans; supports StackWise-80.
C9200L-24T-4G	Stackable 24x1G ports; 4x1G SFP fixed uplink ports; 2 power supply slots; 2 fixed fans; supports StackWise-80.
C9200L-24T-4X	Stackable 24x1G ports; 4x10G SFP+ fixed uplink ports; 2 power supply slots; 2 fixed fans; supports StackWise-80.
C9200L-48P-4G	Stackable 48x1G PoE+ ports; 4x1G SFP fixed uplink ports; 2 power supply slots; 2 fixed fans; supports StackWise-80.
C9200L-48P-4X	Stackable 48x1G PoE+ ports; 4x10G SFP+ fixed uplink ports; 2 power supply slots; 2 fixed fans; supports StackWise-80.
C9200L-48T-4G	Stackable 48x1G ports; 4x1G SFP fixed uplink ports; 2 power supply slots; 2 fixed fans; supports StackWise-80.
C9200L-48T-4X	Stackable 48x1G ports; 4x10G SFP+ fixed uplink ports; 2 power supply slots; 2 fixed fans; supports StackWise-80.

Switch Model	Description
C9200L-24PXG-4X	Stackable 8xMultigigabit Ethernet PoE+ ports and 16x1G PoE+ ports; 4x10G SFP+ fixed uplink ports; 2 power supply slots; 2 fixed fans; supports StackWise-80.
C9200L-24PXG-2Y	Stackable 8xMultigigabit Ethernet PoE+ ports and 16x1G PoE+ ports; 2x25G SFP28 fixed uplink ports; 2 power supply slots; 2 fixed fans; supports StackWise-80.
C9200L-48PXG-4X	Stackable 12xMultigigabit Ethernet PoE+ ports and 36x1G PoE+ ports; 4x10G SFP+ fixed uplink ports; 2 power supply slots; 2 fixed fans; supports StackWise-80.
C9200L-48PXG-2Y	Stackable 8xMultigigabit Ethernet PoE+ ports and 40x1G PoE+ ports; 2x25G SFP28 fixed uplink ports; 2 power supply slots; 2 fixed fans; supports StackWise-80.
C9200L-48PL-4G	Stackable 48x1G PoE+ ports with partial PoE support; 4x1G SFP fixed uplink ports; 2 power supply slots; 2 fixed fans; supports StackWise-80.
C9200L-48PL-4X	Stackable 48x1G PoE+ ports with partial PoE support; 4x10G SFP fixed uplink ports; 2 power supply slots; 2 fixed fans; supports StackWise-80.

Table 2: C9200 Switch Models and Descriptions

Switch Model	Description
C9200-24P	Stackable 24x1G PoE+ ports; 4x1G and 4x10G network modules for uplink ports; 2 power supply slots; 2 field-replaceable fans; supports StackWise-160.
C9200-24PB	Stackable 24x1G PoE+ ports; 4x1G and 4x10G network modules for uplink ports; 2 power supply slots; 2 field-replaceable fans; supports StackWise-160.
C9200-24T	Stackable 24x1G ports; 4x1G and 4x10G network modules for uplink ports; 2 power supply slots; 2 field-replaceable fans; supports StackWise-160.
C9200-48P	Stackable 48x1G PoE+ ports; 4x1G and 4x10G network modules for uplink ports; 2 power supply slots; 2 field-replaceable fans; supports StackWise-160.
C9200-48PB	Stackable 48x1G PoE+ ports; 4x1G and 4x10G network modules for uplink ports; 2 power supply slots; 2 field-replaceable fans; supports StackWise-160.
C9200-48T	Stackable 48x1G ports; 4x1G and 4x10G network modules for uplink ports; 2 power supply slots; 2 field-replaceable fans; supports StackWise-160.

Switch Model	Description
C9200-24PXG	Stackable 8 Multigigabit Ethernet and 16x1G PoE+ ports; supports 4x10G, 2x25G and 2x40G network modules for uplink ports; 2 power supply slots; 2 field-replaceable fans; supports StackWise-160.
C9200-48PXG	Stackable 8 Multigigabit Ethernet and 40x1G PoE+ ports; supports 4x10G, 2x25G and 2x40G network modules for uplink ports; 2 power supply slots; 2 field-replaceable fans; supports StackWise-160.
C9200-48PL	Stackable 48x1G PoE+ ports with partial PoE support; 4x1G and 4x10G network modules for uplink ports; 2 power supply slots; 2 field-replaceable fans; supports StackWise-160.

Front Panel Components

This section describes the front panel components of Cisco Catalyst 9200 Series switches :

- 24 or 48 downlink ports of one of the following types:
 - 10/100/1000
 - 10/100/1000 PoE+
- 1G/10G Uplink ports
- USB Type A storage ports
- USB mini-Type B console port
- LEDs
- Blue Beacon



Note The Cisco Catalyst 9200 Series switches might have slight cosmetic differences on the bezels.

Front Panel of a C9200L Switch

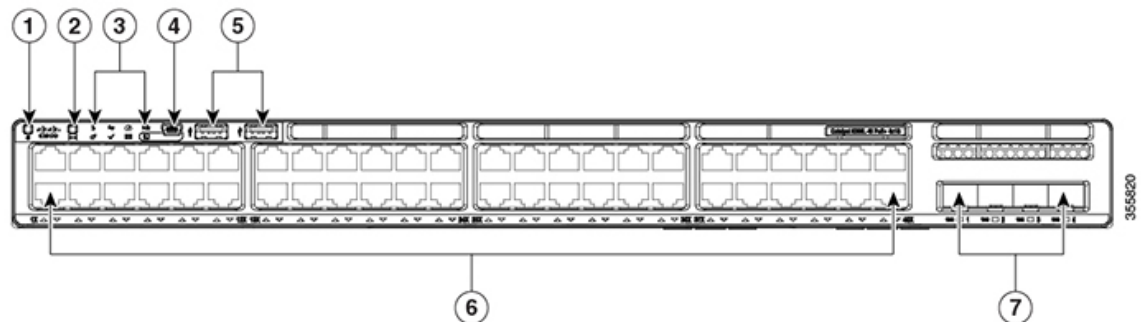

1	Blue Beacon (UID button)	5	USB Type A storage ports
2	Mode button	6	10/100/1000 PoE+ ports
3	Status LEDs	7	Fixed uplink ports
4	USB mini-Type B (console) port		

Front Panel of a C9200 Switch

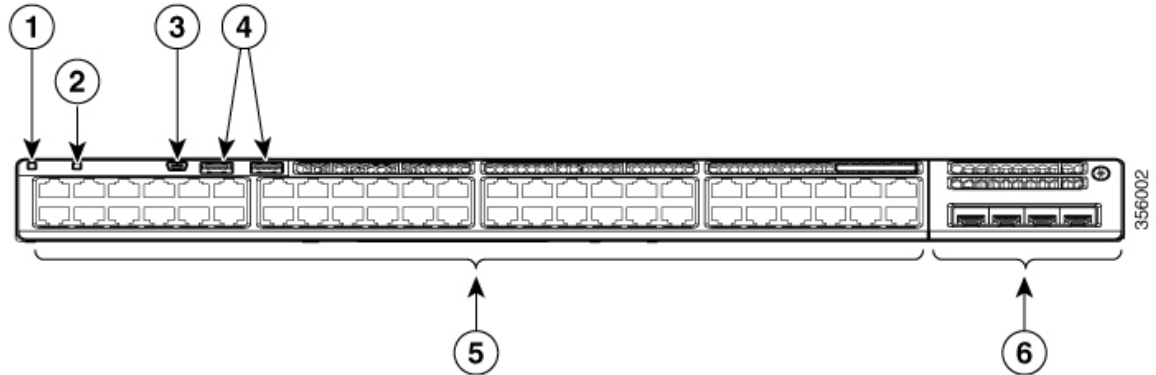

1	Blue Beacon (UID button)	4	USB Type A storage ports
2	Mode button	5	10/100/1000 PoE+ ports
3	USB mini-Type B (console) port	6	Network Module with uplink ports

10/100/1000 Ports

The 10/100/1000 ports use RJ-45 connectors with Ethernet pinouts. The maximum cable length is 328 feet (100 meters). The 100BASE-TX and 1000BASE-T traffic requires twisted pair (UTP) cable of Category 5 or higher. The 10BASE-T traffic can use Category 3 cable or higher.

PoE and PoE+ Ports

The PoE and PoE+ ports provide the following functionality:

- PoE/PoE+ ports: Support for IEEE 802.3af-compliant powered devices (up to 15.4W PoE per port) and support for IEEE 802.3at-compliant powered devices (up to 30W PoE+ per port).
- Support for pre-standard Cisco powered devices.
- Configurable support for Cisco intelligent power management, including enhanced power negotiation, power reservation, and per-port power policing.

See the [Power Supply Modules, on page 9](#) for the power supply matrix that defines the available PoE and PoE+ power per port. The PoE circuit has been evaluated to meet the limits for Limited Power Source (LPS) per Annex Q in IEC/UL 62368-1. It has also been evaluated as a class ES1, PS2.

Multigigabit Ethernet Ports

The Multigigabit (mGig) Ethernet ports can be configured to auto-negotiate multiple speeds on switch ports. The ports support 100 Mbps, 1 Gbps, 2.5 Gbps, and 5 Gbps speeds on Category 5e (Cat5e) cables, and up to 10 Gbps over Category 6 (Cat6) and Category 6A (Cat6A) cables up to a maximum of 100 m. 10Gbps over Cat6 cable is limited for distances up to 55 m. For 10GBASE-T, Cat6a can support up to 100 m when transmitting 10Gbps. Due to the extra bandwidth requirements from the cable, additional limitations exist for best performance. These limitations include, but are not limited to cable reach, cable bundling parameters (tightness, frequency, number of cables, speed with respect to each cable) and cable termination quality.

The 802.3 channel requirements for interoperability typically limit the cable reach to 100 m, but other factors can shorten this reach. In addition, for both Cisco UPOE and Cisco UPOE+ and data integrity, the 100 m total should not include more than 10 m total stranded or patch cable. Therefore, it is assumed that a 100 m link includes a maximum of two 5 m patch cables of the appropriate category, and 90 m of plenum or riser (i.e. solid copper core) cables. Ensure that you follow the TIA guidance on cable dressing.

It is recommended to test the complete link using an appropriate cable tester for 10 Gbps as well as 5 Gbps links. However, even if the link passes cable testing, it is still prone to occasional errors due to aggressors in the bundle, and physical disturbances of the cables. As an example of bundling limitations, for 5 Gbps with cat5e cable, only a total 45 m bundled length is supported; the remaining 55 m should be unbundled. For bundling, follow [Cisco Guidelines and Best Practices for the Installation and Maintenance of Data Networking Equipment](#) which recommends the use of Velcro ties every 1 to 2 m for bundled sections.

If you are upgrading the network gear but reusing the existing cable plant, note that at speeds above 2.5 Gbps traditional Cat5e channel specifications do not support full 100 m reach. To ensure 5 Gbps link speeds, we recommend using Cat6a cabling. For more information, see the Whitepaper from NBASE-T alliance, which has now merged with Ethernet Alliance, archived at <https://archive.nbase-t.ethernetalliance.org/library/white-paper-2/>.



Note Multigigabit ports do not support half duplex mode. Use full duplex mode.

Management Ports

The management ports connect the switch to a PC running Microsoft Windows or to a terminal server.

- Ethernet management port. See [Ethernet Management Port, on page 12](#).
- RJ-45 console port (EIA/TIA-232). See [RJ-45 Console Port, on page 13](#).
- USB mini-Type B console port (5-pin connector).

The 10/100/1000 Ethernet management port connection uses a standard RJ-45 crossover or straight-through cable. The RJ-45 console port connection uses the supplied RJ-45-to-DB-9 female cable. The USB console port connection uses a USB Type A to 5-pin mini-Type B cable. The USB console interface speeds are the same as the RJ-45 console interface speeds.

If you use the USB mini-Type B console port, the Cisco Windows USB device driver must be installed on any PC connected to the console port (for operation with Microsoft Windows). Mac OS X or Linux do not require special drivers.

The 4-pin mini-Type B connector resembles the 5-pin mini-Type B connectors. They are not compatible. Use only the 5-pin mini-Type B.

Figure 1: USB Mini-Type B Port

This illustration shows a 5-pin mini-Type B USB port.

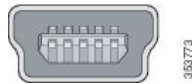

With the Cisco Windows USB device driver, you can connect and disconnect the USB cable from the console port without affecting Windows HyperTerminal operations.

The console output always goes to both the RJ-45 and the USB console connectors, but the console input is active on only one of the console connectors at any one time. The USB console takes precedence over the RJ-45 console. When a cable is connected into the USB console port, the RJ-45 console port becomes inactive. Conversely, when the USB cable is disconnected from the USB console port, the RJ-45 port becomes active.

You can use the command-line interface (CLI) to configure an inactivity timeout which reactivates the RJ-45 console if the USB console has been activated and no input activity has occurred on the USB console for a specified time.

After the USB console deactivates due to inactivity, you cannot use the CLI to reactivate it. Disconnect and reconnect the USB cable to reactivate the USB console. For information on using the CLI to configure the USB console interface, see the Software Configuration Guide.

USB Type A Port

The USB Type A port provides access to external USB flash devices (also known as thumb drives or USB keys).

The port supports Cisco USB flash drives with capacities from 128 MB to 8 GB. USB devices with port densities of 128 MB, 256 MB, 1 GB, 4 GB, and 8 GB are supported. When combined with stacking, you can upgrade other switches in the stack from an USB key inserted in any switch within the stack. Cisco IOS software provides standard file system access to the flash device: read, write, erase, and copy, as well as the ability to format the flash device with a FAT file system.

It provides you with the ability to automatically upgrade the internal flash with the USB drive's configuration and image for emergency switch recovery using USB auto-upgrade. This feature checks the internal flash for a bootable image and configuration and if either image or the configuration is not available, then the USB drive is checked for boot images and configuration. If the boot image and configuration are available, these are copied to flash for the reboot.

Uplink Ports

The Cisco Catalyst 9200 Series switches support both fixed uplinks and modular uplinks. The C9200 switch models support modular uplinks with one hot-swappable network module that provides uplink ports to connect to other devices.

The fixed uplink ports on C9200L switch models support the following types of transceiver modules.

- 4x1G ports that support 1G SFP modules.

- 4x10G ports that support either 1G SFP or 10G SFP+ modules.
- 2x25G ports that support SFP28 modules.

For supported Cisco pluggable transceiver modules (SFP, SFP, SFP28 and QSFP+ modules), refer to the Cisco Transceiver Modules Compatibility Information at http://www.cisco.com/en/US/products/hw/modules/ps5455/products_device_support_tables_list.html



Note For information about installing an (uplink) transceiver module, see [Installing a Cisco Pluggable Transceiver Module](#).

Figure 2: Network Module C9200-NM-4G

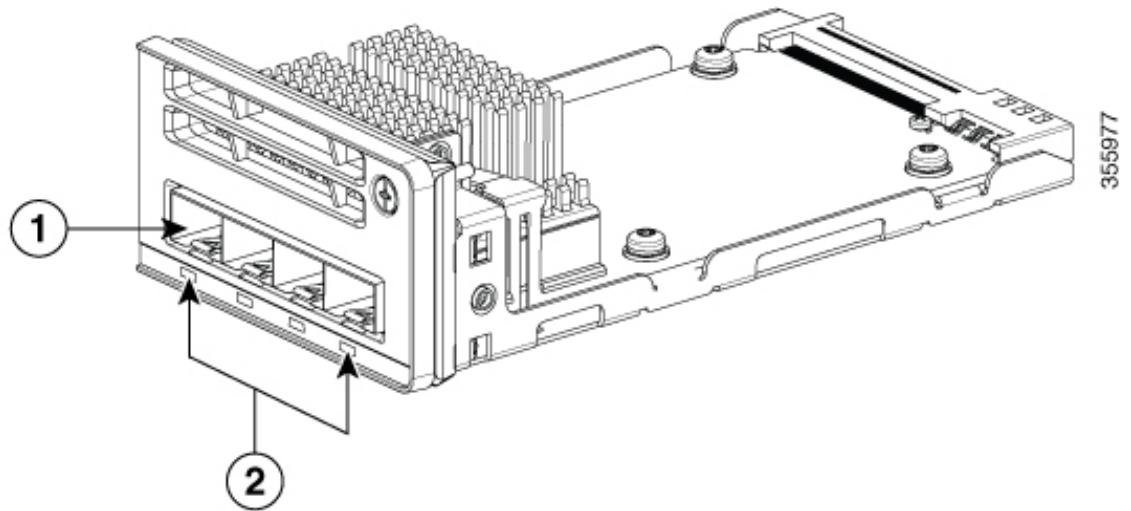

1	Module slot	2	LEDs
---	-------------	---	------

The following table lists the optional Cisco Catalyst 9200 Series Switches uplink network modules with 4x1G, 4x10G, 2x25G, and 2x40G slots.

Table 3: Supported Network Modules

Network Module	Description
C9200-NM-4G	<p>This module has four 1G SFP module slots. Any combination of standard SFP modules is supported. SFP+ modules are not supported.</p> <p>If you insert an SFP+ module in the 1G network module, the SFP+ module does not operate, and the switch logs an error message. This module is not supported on C9200 Multigigabit Ethernet switches.</p>

Network Module	Description
C9200-NM-4X	This module has four 10G SFP module slots. Each port supports a 1G or 10G connection. Any combination of standard SFP modules is supported. This module is supported on both 1G and Multigigabit Ethernet switch models of C9200 switches.
C9200-NM-2Y	This module has two 25 Gigabit Ethernet SFP28 module slots. Any combination of SFP, SFP+, and SFP28 modules are supported. This module is supported only on C9200 Multigigabit Ethernet switches.
C9200-NM-2Q	This module has two 40G slots with a QSFP+ connector in each slot. This module is supported only on C9200 Multigigabit Ethernet switches.
C9200-NM-BLANK	Insert this blank module when the switch has no uplink ports to enable sufficient airflow.



Note For information about installing a network module, see [Installing a Network Module](#).

Rear Panel

The switch rear panel includes StackWise connectors, fan modules, and power supply modules.

Figure 3: Rear Panel of a C9200L Switch

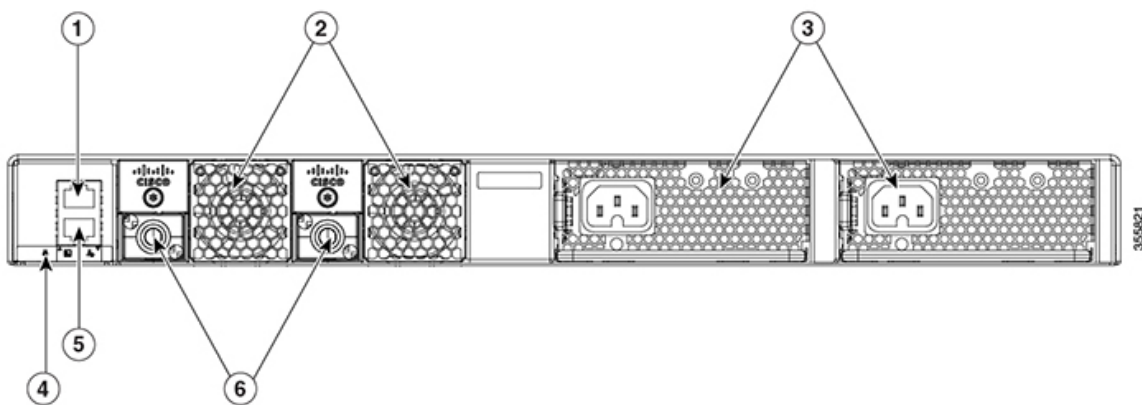

1	RJ-45 console port	4	Blue Beacon LED
2	Fixed fan modules on C9200L switches	5	MGMT (RJ-45 10/100/1000 management port)
3	Power supply module slots	6	StackWise-80 port connectors

Figure 4: Rear Panel of a C9200 Switch

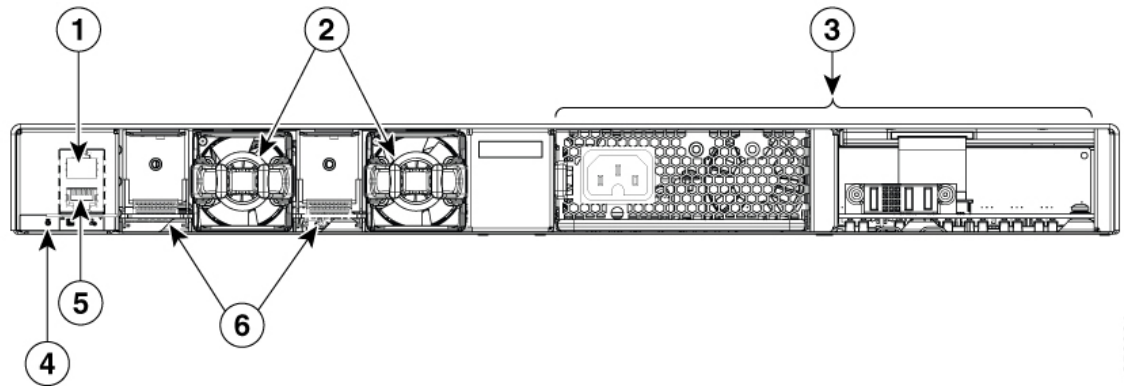

356001

1	RJ-45 console port	4	Blue Beacon LED
2	Modular fan modules on C9200 switches	5	MGMT (RJ-45 10/100/1000 management port)
3	Power supply module slots	6	StackWise-160 port connector slots with stack blanks installed

RFID Tag

The switch has a built-in, front-facing, passive RFID tag that uses UHF RFID technology and requires an RFID reader with compatible software. It provides auto-identification capabilities for asset management and tracking. The RFID tags are compatible with the Generation 2 GS1 EPC Global Standard and are ISO 18000-6C compliant. They operate in the 860- to 960-MHz UHF band. For more information, see [Radio Frequency Identification \(RFID\) on Cisco Catalyst 9000 Family Switches White Paper](#).

StackWise Ports

StackWise ports are used to connect switches in StackWise stacking configurations. The switch ships with a 0.5-meter StackWise cable that you can use to connect the StackWise ports. For more information on StackWise cables, see [Connecting to the StackWise Ports](#).



Caution Use only approved cables, and connect only to similar Cisco equipment. Equipment might be damaged if connected to nonapproved Cisco cables or equipment.

Power Supply Modules

The switch has a field replaceable main AC power supply module and a redundant hot-swappable field replaceable AC power supply module. The switch is powered through one or two internal power supply modules. In switches with PoE capability, the redundant power supply can also be used for extra PoE power.

Following are the power supply modules supported on Cisco Catalyst 9200 Series Switches:

- PWR-C5-125WAC
- PWR-C5-600WAC
- PWR-C5-1KWAC
- PWR-C6-125WAC
- PWR-C6-600WAC
- PWR-C6-1KWAC

The switch has two internal power supply module slots. You can use two AC power supply modules or one power supply module and a blank module (PWR-C5-BLANK).

The switch can operate with either one or two active power supply modules.

[Switch Models, on page 1](#) shows the default power supply modules that ship with each switch model. All power supply modules (except the blank modules) have internal fans. All switches ship with a blank power supply module in the second power supply slot. Each AC power supply module has a power cord (CAB-TA-XXX) for connection to an AC power outlet.



Caution Do not operate the switch with one power supply module slot empty. For proper chassis cooling, both power supply module slots must be populated with either a power supply or a blank module.

The power supply modules are autoranging units that support input voltages between 100 and 240 VAC. The output voltage range is 12 to 12.5 V for 125W power supply and 54 to 56 V for 600W and 1000W power supplies.

All the PoE-enabled switches when installed with both the power supplies support full PoE+; 1440W on a 48-port switch and 740W on a 24-port switch. The partial PoE-enabled switches support only 600W power supply providing a PoE budget of 370W. If the switch is installed with one power supply, the available POE budget is 370W and 740W, if there are two power supplies installed.

The following tables show the PoE available and PoE requirements for PoE switch models.

Table 4: Available PoE with AC Power Supply

Models	Default Power Supply	Available PoE	Full PoE with Redundant Power Supply
C9200 Switches			
C9200-24P	PWR-C5-600WAC or PWR-C6-600WAC	370W	740W
C9200-48P	PWR-C5-1KWAC or PWR-C6-1KWAC	740W	1440W
C9200-24T	PWR-C5-125WAC or PWR-C6-125WAC	-	-
C9200-48T	PWR-C5-125WAC or PWR-C6-125WAC	-	-

Models	Default Power Supply	Available PoE	Full PoE with Redundant Power Supply
C9200-24PB	PWR-C5-600WAC or PWR-C6-600WAC	370W	740W
C9200-48PB	PWR-C5-1KWAC or PWR-C6-1KWAC	740W	1440W
C9200-48PL	PWR-C5-600WAC or PWR-C6-600WAC	370W	740W
C9200-24PXG	PWR-C5-600WAC or PWR-C6-600WAC	370W	740W
C9200-48PXG	PWR-C5-1KWAC or PWR-C6-1KWAC	740W	1440W
C9200L Switches			
C9200L-24P-4G	PWR-C5-600WAC	370W	740W
C9200L-24P-4X	PWR-C5-600WAC	370W	740W
C9200L-24PXG-2Y	PWR-C5-600WAC	370W	740W
C9200L-24PXG-4X	PWR-C5-600WAC	370W	740W
C9200L-24T-4G	PWR-C5-125WAC	—	—
C9200L-24T-4X	PWR-C5-125WAC	—	—
C9200L-48P-4G	PWR-C5-1KWAC	740W	1440W
C9200L-48P-4X	PWR-C5-1KWAC	740W	1440W
C9200L-48PL-4G	PWR-C5-600WAC	370W	740W
C9200L-48PL-4X	PWR-C5-600WAC	370W	740W
C9200L-48PXG-2Y	PWR-C5-1KWAC	740W	1440W
C9200L-48PXG-4X	PWR-C5-1KWAC	740W	1440W
C9200L-48T-4G	PWR-C5-125WAC	—	—
C9200L-48T-4X	PWR-C5-125WAC	—	—

The power supply modules have two status LEDs.

Table 5: Switch Power Supply Module LEDs

→]	Description	←]	Description
Off	No AC input power.	Off	Output is disabled, or input is outside operating range (AC LED is off).
Green	AC input power present.	Green	Power output to switch active.
		Red	Output has failed.

Fan Modules

The Cisco Catalyst 9200 Series Switches supports two internal fixed 12-V fan modules and two field-replaceable fan modules (C9200-FAN=). The C9200 models support modular fans whereas the C9200L models provide two internal fixed fans.

For information about the type of fan module supported on different switch models, see [Switch Models, on page 1](#).

The air circulation system consists of the fan modules and the power supply modules. The airflow patterns vary depending on the power supply configuration. The switch can operate at ambient temperature if one of the fans fail.

Figure 5: Switch Airflow Pattern

The following illustration shows the airflow pattern for the switches. The blue arrow shows cool airflow, and the red arrow shows warm airflow.

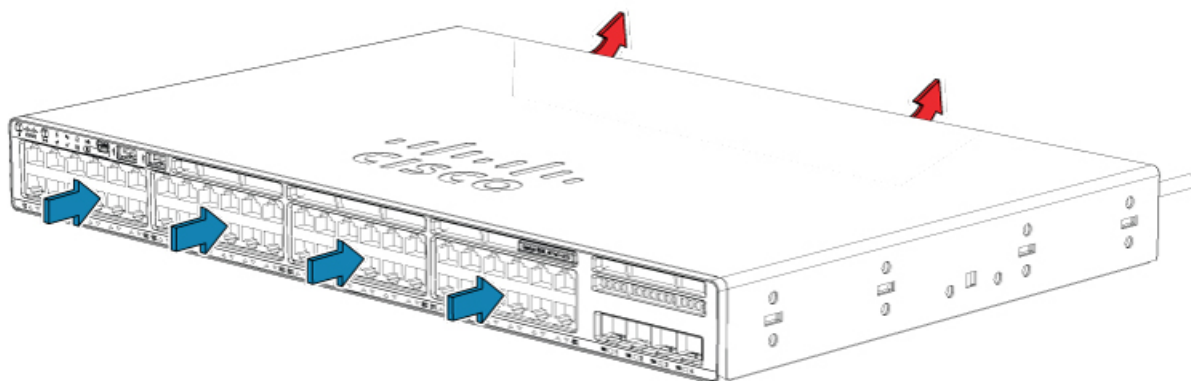

356592

Ethernet Management Port

You can connect the switch to a host such as a Windows workstation or a terminal server through the 10/100/1000 Ethernet management port or one of the console ports. The 10/100/1000 Ethernet out-of-band management port is a virtual routing and forwarding (VRF) interface and uses a RJ-45 crossover or straight-through cable.



Note The 10/100/1000 Ethernet management port is an RJ-45 connector that should be connected to a Windows workstation or a terminal server. Do not connect this port to another port in the same switch or to any port within the same switch stack.

The following table shows the Ethernet management port LED colors and their meanings.

Table 6: Ethernet Management Port LED

Color	Description
Green	Link up but no activity.
Blinking green	Link up and activity.
Off	Link down.

RJ-45 Console Port

The RJ-45 console port connection uses the supplied RJ-45-to-DB-9 female cable.

The following table shows the RJ-45 console port LED colors and their meanings.

Table 7: RJ-45 Console LED

Color	Description
Green	RJ-45 console port is active.
Off	The port is not active.

Network Configurations

See the switch software configuration guide for network configuration concepts and examples of using the switch to create dedicated network segments and interconnecting the segments through Fast Ethernet and Gigabit Ethernet connections.

