



Maintenance and Service Guide

HP 27mq model

SUMMARY

This guide provides information about spare parts, removal and replacement of parts, diagnostic tests, problem troubleshooting, and more.

© Copyright 2021 HP Development Company, L.P.

AMD is a trademark of Advanced Micro Devices, Inc. Bluetooth is a trademark owned by its proprietor and used by HP Inc. under license. NVIDIA is a trademark and/or registered trademark of NVIDIA Corporation in the U.S. and other countries. USB Type-C and USB-C are registered trademarks of USB Implementers Forum. DisplayPort and the DisplayPort logo are trademarks owned by the Video Electronics Standards Association (VESA) in the United States and other countries.

The information contained herein is subject to change without notice. The only warranties for HP products and services are set forth in the express warranty statements accompanying such products and services. Nothing herein should be construed as constituting an additional warranty. HP shall not be liable for technical or editorial errors or omissions contained herein.

First Edition June 2021

Document Part Number: L75252-HP 27mq-MSG-V1

Assembly part number: L75252-001

Product notice

Only trained service personnel familiar with this product should service it. Before performing any maintenance or service, be sure to read "Important Safety Information".

Table of Contents

| | | |
|---|-------------------------------------------------------------|----|
| 1 | Getting started | 1 |
| | Important safety information..... | 1 |
| | Important service information and precautions..... | 1 |
| | RoHS (2002/95/EC) requirements..... | 2 |
| | General descriptions | 2 |
| | Firmware updates..... | 2 |
| | Before returning the repaired product to the customer | 2 |
| 2 | Monitor features | 3 |
| | Features | 3 |
| | Front components..... | 4 |
| | Rear components | 5 |
| | Locating the serial number and product number..... | 6 |
| 3 | Illustrated parts catalog..... | 7 |
| | How to order parts..... | 8 |
| 4 | Removal and replacement procedures | 9 |
| | Preparation for disassembly..... | 9 |
| | RC | 10 |
| | Power board..... | 15 |
| | Connector repair..... | 16 |
| | HDMI connector CN503..... | 17 |
| | D-SUB connector CN101..... | 18 |
| | Function test..... | 19 |
| | Function test..... | 19 |
| | Support and troubleshooting..... | 19 |
| | Index..... | 20 |

1 Getting started

Read this chapter to learn about safety information and where to find additional HP resources.

Important safety information

A power cord is included with the monitor. If you use another cord, use only a power source and connection appropriate for this monitor. For information about the correct power cord set to use with the monitor, see the *Product Notices* provided in your documentation kit.

WARNING! To reduce the risk of electric shock or damage to the equipment:

- Plug the power cord into an AC outlet that is easily accessible at all times.
- If the power cord has a 3-pin attachment plug, plug the cord into a grounded (earthed) 3-pin outlet.
- Disconnect power from the computer by unplugging the power cord from the AC outlet. When unplugging the power cord from the AC outlet, grasp the cord by the plug.

For your safety, do not place anything on power cords or cables. Care should be taken to route all cords and cables connected to the monitor so that they cannot be stepped on, pulled, grabbed, or tripped over.

To reduce the risk of serious injury, read the *Safety & Comfort Guide* provided with your user guides. It describes proper workstation setup and proper posture, health, and work habits for computer users. The *Safety & Comfort Guide* also provides important electrical and mechanical safety information. The *Safety & Comfort Guide* is also available on the Web at <http://www.hp.com/ergo>.

IMPORTANT: For the protection of the monitor and the computer, connect all power cords for the computer and its peripheral devices (such as a monitor, printer, scanner) to a surge protection device such as a power strip or uninterruptible power supply (UPS). Not all power strips provide surge protection; the power strip must be specifically labeled as having this capability. Use a power strip whose manufacturer offers a damage replacement policy so that you can replace the equipment if surge protection fails.

Use the appropriate and correctly sized furniture designed to properly support your monitor.

WARNING! Monitors that are inappropriately situated on dressers, bookcases, shelves, desks, speakers, chests, or carts could fall over and cause personal injury.

NOTE: This product is suitable for entertainment purposes. Consider placing the monitor in a controlled luminous environment to avoid interference from surrounding light and bright surfaces that might cause disturbing reflections from the screen.

Important service information and precautions

- Repair must be performed by professional service technicians in a repair center. End users should not perform these procedures.
- Please note during servicing that the primary side is the high voltage area.
- This monitor meets ROHS requirements. Be sure to use lead-free solder wire when soldering.
- If you must change a capacitor, be sure to match the polarity as printed on the PCB.
- If you must replace a capacitor, make sure the specification and part number match the BOM and location.

- If you must replace a capacitor, insert new parts carefully to avoid a short circuit caused by the near pin.
- Do not get the board wet. Water and moisture can cause a short circuit that causes malfunctions.
- To avoid damage, be sure to use lead-free solder.
- When soldering, work quickly to avoid overheating the circuit board.
- Keep the soldering iron tip clean and well tinned when replacing parts.
- After repair, perform a close inspection of the circuit board to confirm it is in good condition.
- After repair, perform a function test to confirm the power supply is working properly.

ERP Lot5 requirement

1. A professional repairer must have the technical competence to repair electronic displays and comply with the applicable regulations for repairers of electrical equipment in the Member States where the repairer operates. Reference to an official registration system as professional repairer, where such a system exists in the Member States, shall be accepted as proof of compliance.
2. A professional repairer must have insurance that covers liabilities resulting from repairs, regardless of whether required by the Member State.

RoHS (2002/95/EC) requirements

Applied to all countries that require RoHS.

The RoHS (Restriction of Hazardous Substance in Electrical and Electronic Equipment Directive) is a legal requirement by the EU (European Union) for the global electronics industry sold in the EU and other countries. Any electrical and electronics products launched in the market after June 2006 should meet this RoHS requirement. Products launched in the market before June 2006 are not required to be compliant with RoHS parts. If the original parts are not RoHS compliant, the replacement parts can be non-ROHS compliant. If the original parts are RoHS compliant, the replacement parts **MUST** be RoHS compliant.

If product service or maintenance requires replacing parts, confirm the RoHS requirement before replacement.

General descriptions

This manual contains general information. There are two levels of service:

Level 1: Cosmetic/appearance/alignment service

Level 2: Circuit board or standard parts replacement

Firmware updates

Firmware updates for the monitor are available at support.hp.com. If no firmware is posted, the monitor does not need a firmware update.

Before returning the repaired product to the customer

Perform an AC leakage current check on exposed metallic parts to be sure the product is safe to operate without the potential of electrical shock. Do not use a line isolation transformer during this check.

Measurements that are not within specified limits present a possible shock hazard. You must check and repair the product before returning it to the customer.

2 Monitor features

This chapter provides an overview of the monitor's features.

Features

This guide describes features of the following monitors:

- 68.6 cm (27.0 in) diagonal viewable screen area with 2560 × 1440 resolution, plus full-screen support for lower resolutions; includes custom scaling for maximum image size while preserving original aspect ratio

The monitor features include the following:

- Nonglare IPS panel with an LED backlight
- Wide viewing angle to allow viewing from a sitting or standing position, or when moving from side to side
- Tilt capability
- Pivot capability to rotate the monitor panel from landscape to portrait mode
- Swivel and height adjustment capabilities
- Removable stand for flexible monitor panel mounting solutions
- VGA video input
- One HDMI (High-Definition Multimedia Interface) video input (cable provided)
- Plug and Play capability, if supported by your operating system
- Security cable slot provision on rear of monitor for optional security cable
- On-screen display (OSD) adjustments in several languages for easy setup and screen optimization
- HP Display Assistant software for adjusting monitor settings and enabling the theft deterrence features
- HDCP (High-bandwidth Digital Content Protection) copy protection on all digital inputs
- Energy saver feature to meet requirements for reduced power consumption

NOTE: For safety and regulatory information, see the *Product Notices* provided on your optical disc, if one is included, or in your documentation kit. To access the latest user guide, go to <http://www.hp.com/support> and following the instructions to find your product. Then select **User Guides**.

Front components

To identify the components on the front of the monitor, use this illustration and table.



Table 1-1: Front components and their descriptions

| Control | Function |
|------------------------------------|------------------------------------------------------------------------------------------------------------------------------------------------------------------------------------------------------------------------------------------------------------------------------------------------------------------------------------------------------------------------------------------------------------------|
| 1 Menu button | Press to open the OSD menu, select a menu item from the OSD, or close the OSD menu. When the OSD menu is open, the Menu light turns on. |
| 2 OSD buttons (assignable) | When the OSD menu is open, press the buttons to navigate through the menu. The function light icons indicate the default button functions. For a description of these functions, see Using the function buttons on page 15 . You can reassign the function buttons to quickly select the most commonly used operations. See Reassigning the function buttons on page 15 . |
| 3 Power button | Turns the monitor on or off. |

Rear components

To identify the components on the rear of the monitor, use this illustration and table.

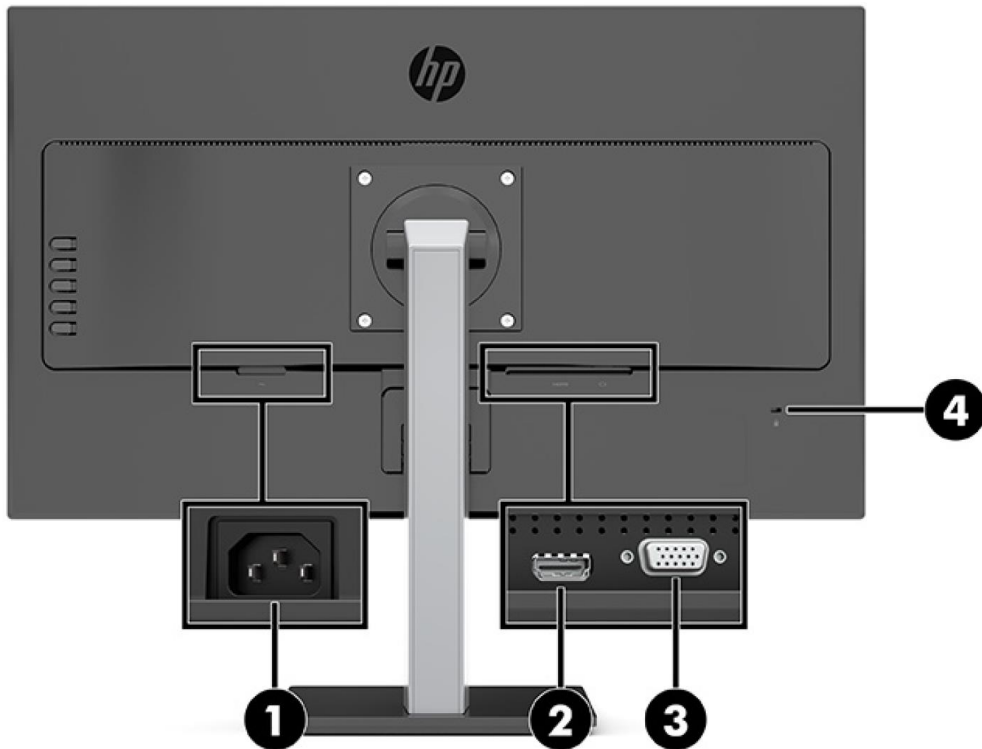
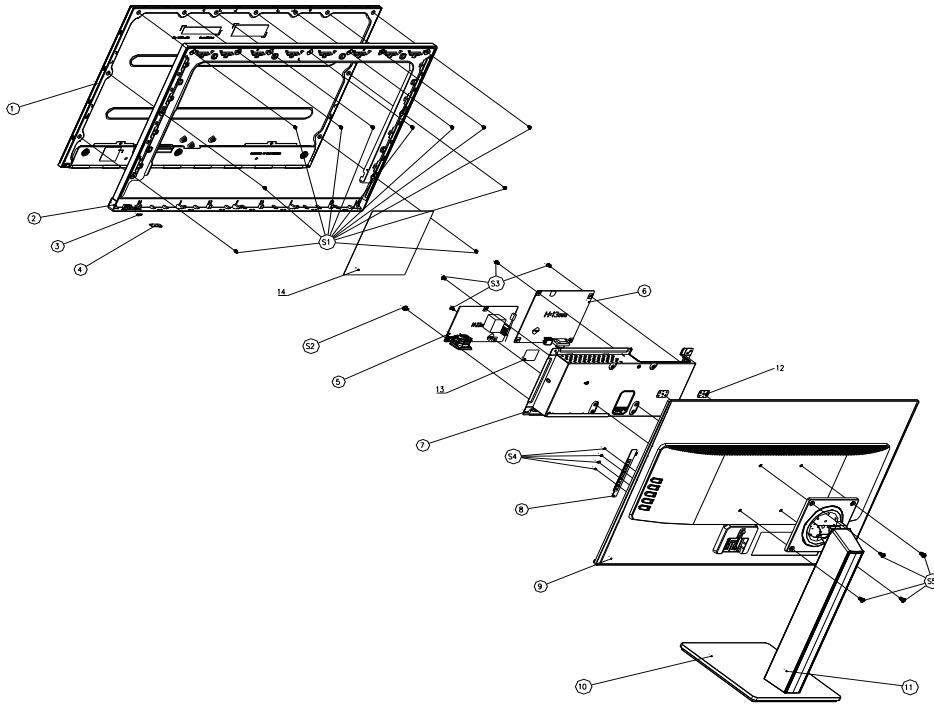

Table 1-1 Rear components

| Component | Function |
|-----------------------|--------------------------------------------------------------------------------|
| 1 Power connector | Connects the power cord. |
| 2 HDMI port | Connects the HDMI cable to a source device such as a computer or game console. |
| 3 VGA port | Connects the VGA cable to the source device. |
| 4 Security cable slot | Connects an optional security cable to the monitor. |

3 Illustrated parts catalog

To identify the monitor major components, use this illustration and table.



| Item | Description | Qty |
|------|----------------------------------------------|-----|
| 1 | PANEL | 1 |
| 2 | MIDDLE_FRAME | 1 |
| 4 | LENS | 1 |
| 5 | LED BOARD | 1 |
| 6 | ADAPTER BOARD | 1 |
| 7 | MAIN BOARD | 1 |
| 8 | MAINFRAME | 1 |
| 9 | KEY BOARD | 1 |
| 10 | REAR_COVER | 1 |
| 10 | BASE_ASS'Y | 1 |
| 11 | stand ass'y | 1 |
| 12 | BKT_VESA | 1 |
| 13 | INSULATING SHEET | 6 |
| 14 | INSULATING SHEET | 1 |
| S1 | SCREW 3 4(MIDDLE FRAME/PANEL) | 11 |
| S2 | SCREW -- 6mm(POWER BOARD/MAINFRAME) | 1 |
| S3 | SCREW D3 6(MAIN BOARD/POWER BOARD/MAINFRAME) | 5 |
| S4 | SCREW(KEY BOARD/MAINFRAME) | 4 |
| S5 | SCREW M4 10(STAND ASSY/REAR COVER) | 4 |

How to order parts

The HP authorized repair center can purchase the power board from HP.

Capacitors and connectors are available for purchase from the following EU distributors:

- RS: [Capacitors | RS Components \(rs-online.com\)](https://www.rs-online.com)
- tme: [Transfer Multisort Elektronik](https://www.tme.eu)
- Digi-Key: [Digikey Electronics](https://www.digikey.com)

Power board

| Description | HP spare part number | Manufacturer part number |
|-------------|----------------------|--------------------------|
| PSU HP 27mq | M84482-001 | ADPCJ1903AA2 |

Capacitors by distributor

| Component description | Location | Component distributor | Distributor part number |
|--------------------------------------------------------------------------|----------|-----------------------|-------------------------|
| EC 470UF 20% 25V 10*16 ED/EC 470UF 20% 25V 10*16 -- 1.21A ECR1EXX4 | C916 | Digi-Key | EEU-FM1E471 |
| EC 470UF 20% 25V 10*16 ED/EC 470UF 20% 25V 10*16 -- 1.21A ECR1EXX4 | C917 | Digi-Key | RZW471M1EBK-1016S |

Connectors by manufacturer

| Component description | Location identifier | Component distributor | Distributor part number |
|-----------------------|---------------------|-----------------------|---------------------------|
| D-SUB | CN101 | tme | HDL15-SL-B (ADAM TECH) |
| HDMI | CN503 | RS | SD-47151-001 (Molex) |

NOTE: Rear cover and chassis need to be modified to hold connector. Connector may need modifications to meet functional, safety and regulatory requirements accordingly if it doesn't match exactly.

You can purchase cables from the HP part store at <https://partsurfer.hp.com/Search.aspx>.

NOTE: HP continually improves and changes product parts. For complete and current information about supported parts for your computer, go to <http://partsurfer.com>, select your country or region, and then follow the on-screen instructions.

4 Removal and replacement procedures

Adherence to these procedures and precautions is essential for proper service.

Preparation for disassembly

Use this information to properly prepare to disassemble and reassemble the monitor.

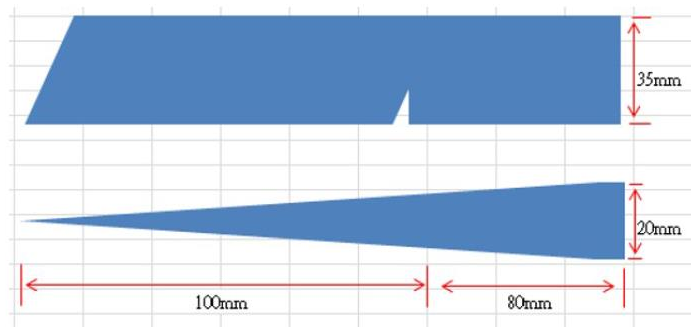

- 1) Read the “Important safety information” and “Important service information and precautions” sections in the “Getting started” chapter of this guide.
- 2) Clean the room for disassembly.
- 3) Identify the disassembly area.
- 4) Check the position that the monitors are to be placed along with the number of monitors. Prepare the area for material flow according to the disassembly layout.
- 5) Be sure to have the following equipment and materials:
 - Press fixture
 - Working table
 - Screwdriver
 - Knife
 - Gloves
 - Cleaning cloth
 - ESD protection
 - Scraper bar in the following dimensions:



RC

Before removing the RC, follow these steps:

- ▲ Prepare the monitor for disassembly. See Preparation for disassembly on page 9.

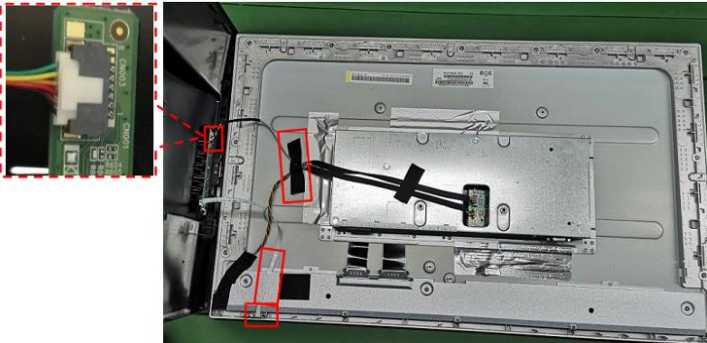
| Step | Figure | Description |
|-------------------------------------------------------|--------------------------------------------------------------------------------------|------------------------------------------------------------------------------------------------------|
| 1. Preparation and remove the stand-base ass'y |  | Lay the monitor on a flat, soft and clean surface. Remove the screws to remove the stand-base ass'y. |
| 2. Remove the rear cover |  | Remove the rear cover |
| 3. Disconnect the cable and the tape |  | Disconnect the cable and the tape |

4. Disconnect the tapes and remove the screws. Remove the Led Board

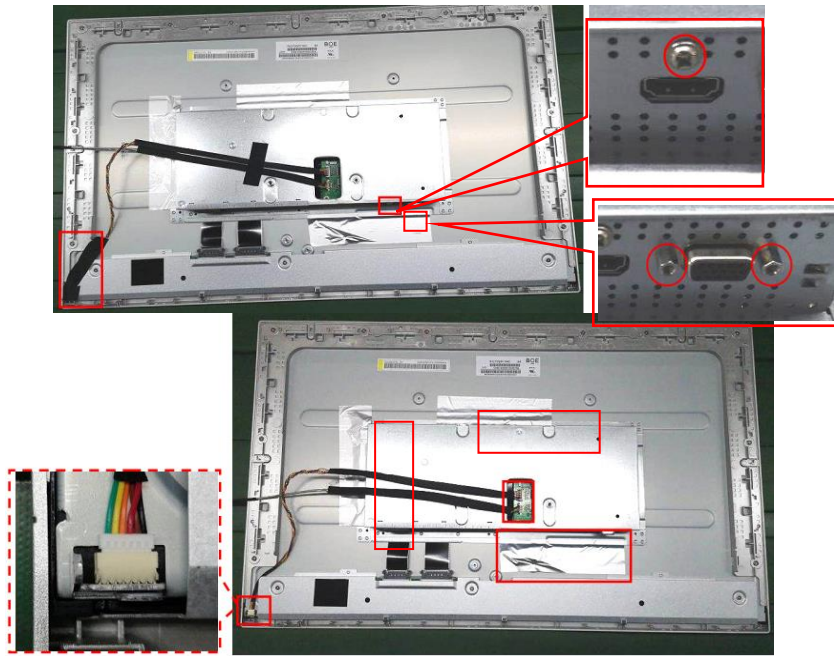

Disconnect the tapes and remove the screws. Remove the LED Board

5. Remove the screws and disconnect the pins.

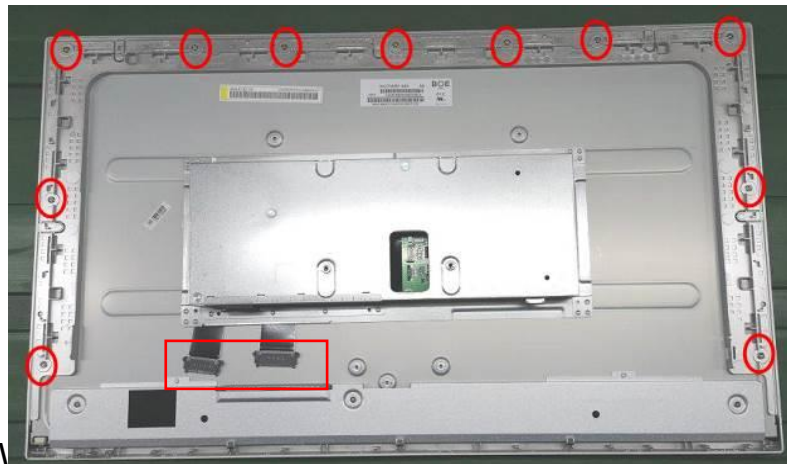

Remove the screws and disconnect the pins.

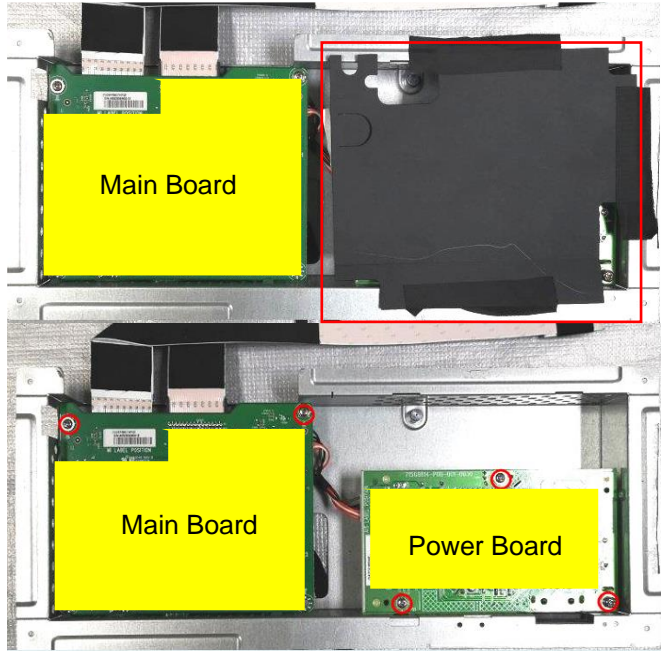
| | | |
|------------------------------------------------------------|------------------------------------------------------------------------------------|------------------------------------------------------------------------------------------|
| <p>6. Remove the main board and the power board</p> |  | <p>Remove the mylar. remove the screws to remove the main board and the power board.</p> |
|------------------------------------------------------------|------------------------------------------------------------------------------------|------------------------------------------------------------------------------------------|

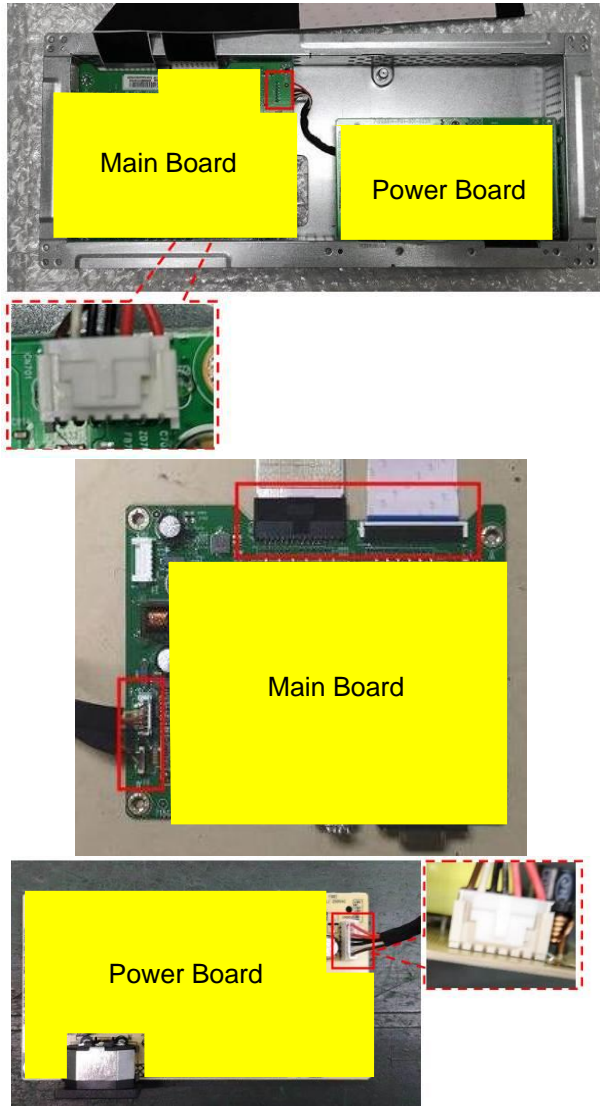
| | | |
|--------------------------------------|-------------------------------------------------------------------------------------|----------------------------|
| <p>7. Disconnect the pins</p> |  | <p>Disconnect the pins</p> |
|--------------------------------------|-------------------------------------------------------------------------------------|----------------------------|

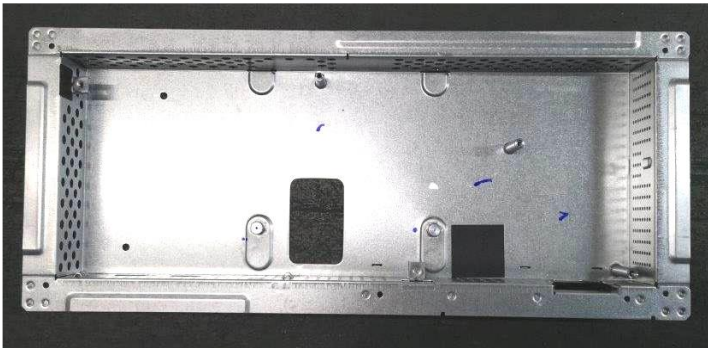
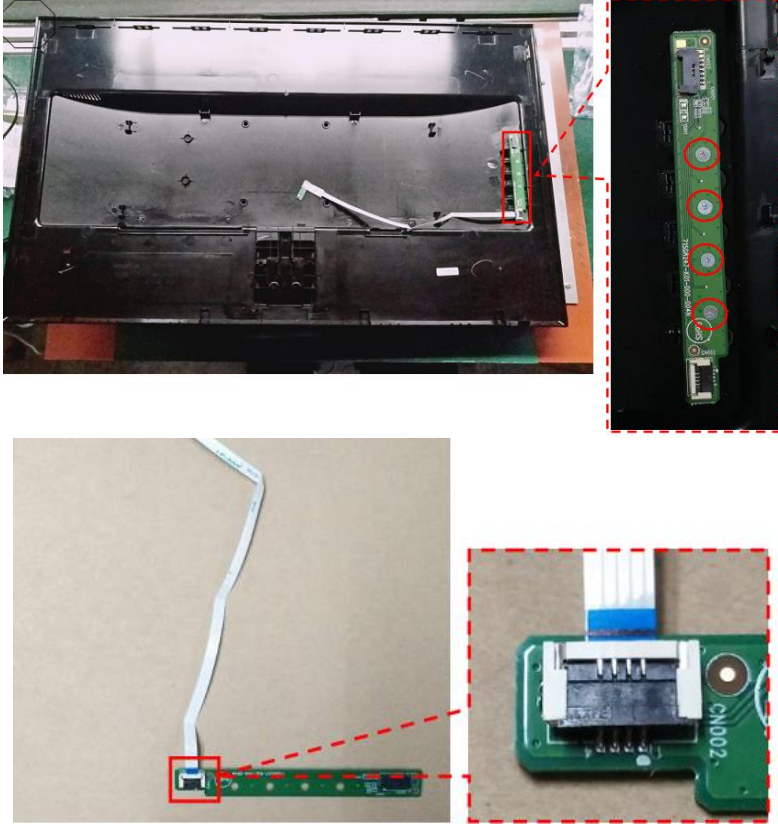
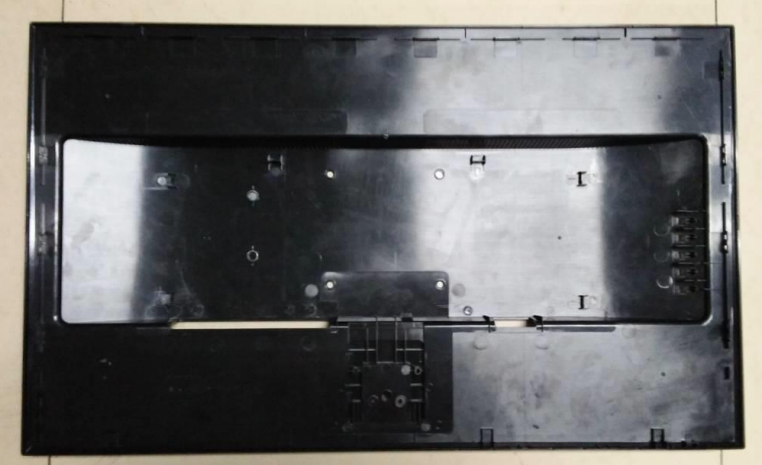
| | | |
|------------------------------------------------------------|--------------------------------------------------------------------------------------|--------------------------------------------------|
| <p>8. The Mainframe</p> |  | <p>The Mainframe</p> |
| <p>9. Remove the screws to remove the key board</p> |  | <p>Remove the screws to remove the key board</p> |
| <p>10. The Rear Cover</p> |  | <p>The Rear Cover</p> |

11. The panel and the bezel



The panel and the Bezel.

Power board

The power board part number is ADPCJ1903AA2

Before removing the power board, follow these steps:

- ▲ Prepare the monitor for disassembly. See Preparation for disassembly on page 9.

Remove the power board:

- 1) The HP 27mq power board connector position is as follows:

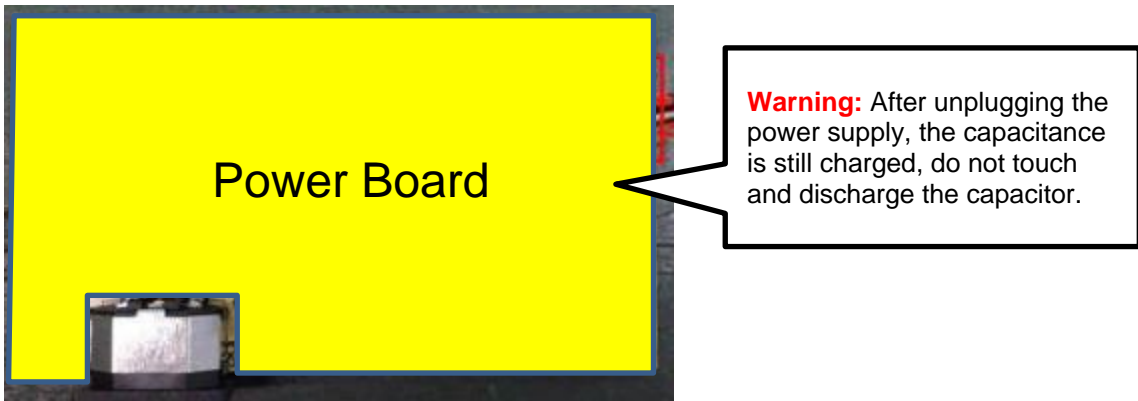

- 2) Locate the part number location on the board.

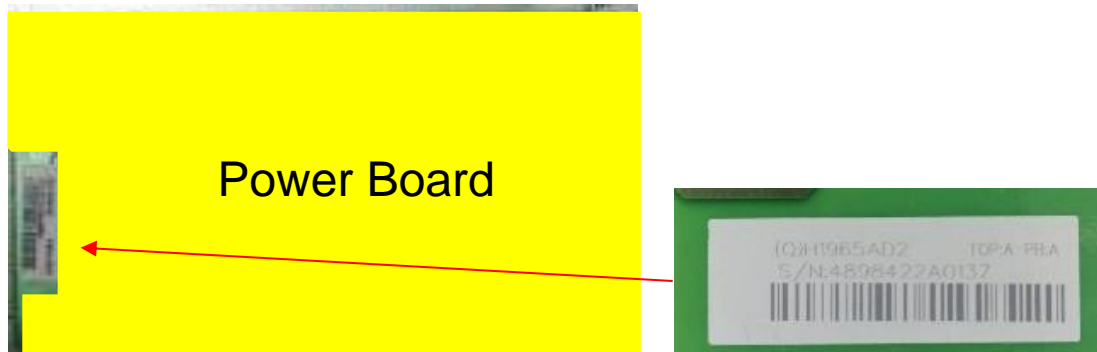

Connector repair

This procedure includes HDMI and D-SUB connectors.

The connectors are on the main board (board part number CBPRNE7HPQ7).

The connectors identifiers are as follows:

| Connector | Location |
|-----------|----------|
| HDMI | CN503 |
| D-SUB | CN101 |

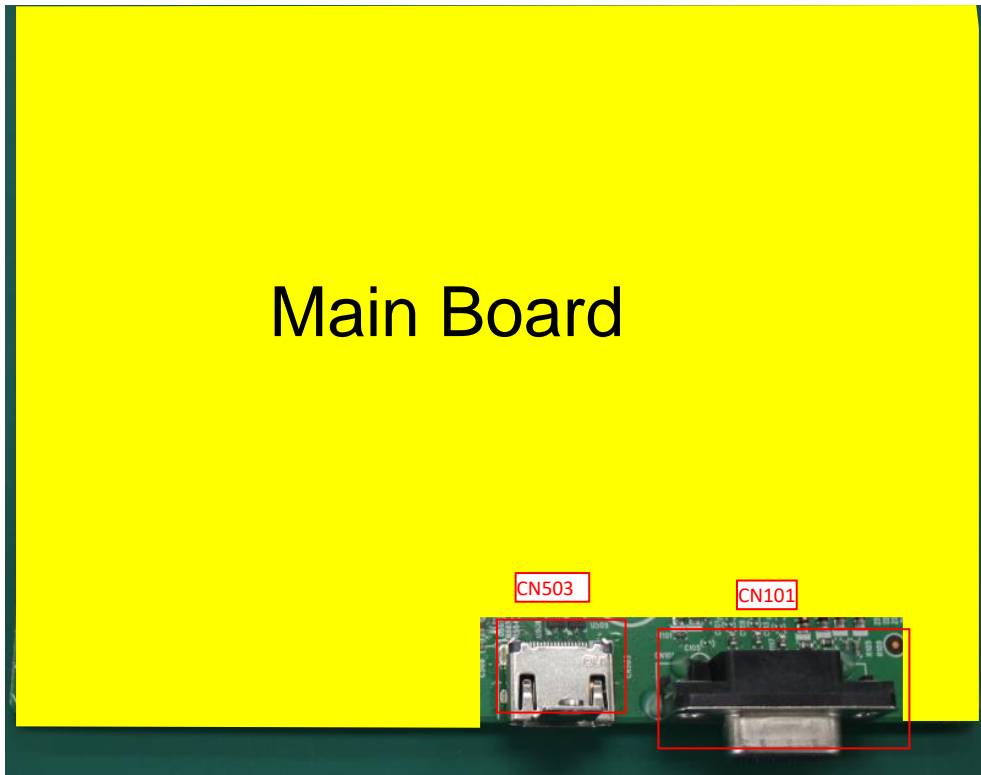

Before repairing connectors, follow these steps:

- ▲ Prepare the monitor for disassembly. See [Preparation for disassembly](#) on page 9.

IMPORTANT:

- **Repair Condition: Connector repair is only for out of warranty.**
- **Repairing must operate by professional repairers (Note) in repair center, not applicable for end user.**
- **Electrostatic protection is required when component replacement is required.**
- **The monitor meets ROHS, please use Lead-free solder wire for soldering.**
- **If Connector need to replace, must check specification and part number whether match the BOM and location.**
- **If connector need to replace, please insert new parts carefully because the near pin may cause short circuit by inappropriate operate.**
- **DO NOT allow any liquid on the board. Water and moisture may cause short-circuit to the electronic components and lead to malfunctions.**
- **The fusion point of Lead-Free solder is requested. Repairing with conventional lead wire may cause damage.**
- **Work quickly to avoid overheating the circuit board as soon as you confirm the steady soldering condition.**
- **Keep the soldering iron tip clean and well tinned and when replacing parts.**
- **A close inspection of the circuit board revealed look in good condition.**
- **After repaired, must connect source to each port to check Main board function is ordinary.**

Note: (The requirement of professional repairers' regulation by ERP lot5)

- 1) The professional repairer has the technical competence to repair electronic displays and complies with the applicable regulations for repairers of electrical equipment in the Member States where it operates. Reference to an official registration system as professional repairer, where such system exists in the Member States concerned, shall be accepted as proof of compliance with this point.
- 2) The professional repairer is covered by insurance covering liabilities resulting from its activity, regardless of whether this is required by the Member State.

HDMI connector CN503

Repair the HDMI connector:

- 1) Use a soldering iron and a desoldering pump to remove as much solder as possible from the pin.

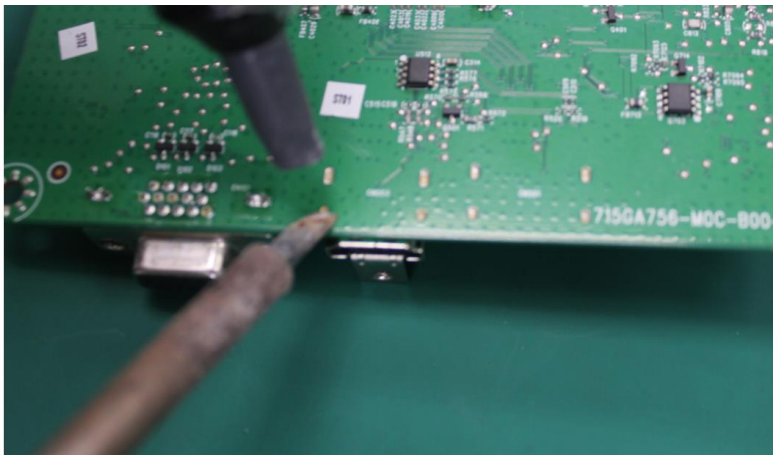

- 2) Use a hot air gun to melt the solder on the pins.

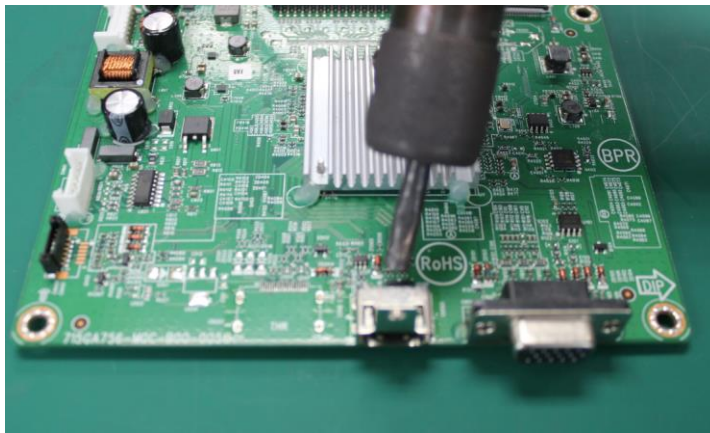

- 3) Lift the CN503 connector from the PCB.
- 4) Place the new component on the PCB. Be sure that it matches the PCB footprint.
- 5) Solder the new component.

D-SUB connector CN101

Repair the D-SUB connector:

- 1) Use a soldering iron and a desoldering pump to remove as much solder as possible from the pin.



- 2) Use a hot air gun to melt the solder on the pins.
- 3) Lift the CN101 connector from the PCB.
- 4) Place the new component on the PCB. Be sure that it matches the PCB footprint.
- 5) Solder the new component.

Function test

After repair, be sure to confirm that all functions are working.

Table 4-1: Function test

| Test item | Operating description | Tool used |
|------------|--------------------------------------------------------------------------|--------------------------|
| HDMI test | Confirm whether image displays and sound plays correctly on the monitor. | Computer or DVD player |
| D-SUB test | Confirm whether image displays and sound plays correctly on the monitor | Computer or D-SUB player |

Support and troubleshooting

The following table lists possible problems, the possible cause or each problem, and the recommended solutions.

Table 3-1 Common issues and solutions

| Issues | Possible cause | Solution |
|----------------------------------------------------------|--------------------------------------------------------------------------------|---------------------------------------------------------------------------------------------------------------------------------------------------------------------------------------------------------------------------------------------------|
| Screen is blank or video is flashing. | Power cord is disconnected. | Connect the power cord. |
| | Monitor is off. | Press the monitor power button. NOTE: If pressing the power button has no effect, press and hold the power button for 10 seconds to disable the Power Button Lockout feature. |
| | Video cable is improperly connected. | Connect the video cable properly. See Connecting the cables on page 7 for more information. |
| | System is in Auto-Sleep Mode. | Press any key on the keyboard or move the mouse to inactivate the screen blanking utility. |
| | Video card is incompatible. | Open the OSD menu and select the Input menu. Set Auto-Switch Input to Off and manually select the input. or Replace the video card or connect the video cable to one of the computer's on-board video sources. |
| Image appears blurred, indistinct, or too dark. | Brightness setting is too low. | Open the OSD menu, and select Brightness to adjust the brightness scale as needed. |
| "Check Video Cable" is displayed on the screen. | Monitor video cable is disconnected. | Connect the appropriate video signal cable between the computer and monitor. Be sure that the computer power is off while connecting the video cable. |
| "Input Signal Out of Range" is displayed on screen. | Video resolution and/or refresh rate are set higher than the monitor supports. | Change the settings to a supported setting (see Preset display resolutions on page 26). |
| The monitor does not enter into a low-power sleep state. | The monitor's power saving control is disabled. | Open the OSD menu and select Power , select Auto-Sleep Mode , and then set auto-sleep to On . |
| "OSD Lockout" is displayed. | The monitor's OSD Lockout function is enabled. | Press and hold the Menu button for 10 seconds to disable the OSD Lockout function. |
| "Power Button Lockout" is displayed. | The monitor's Power Button Lockout feature is enabled. | Press and hold the Power button for 10 seconds to unlock the power button function. |

Index

- components
 - front, 4
 - rear, 5
- features, 3
- firmware updates, 2
- front components, 4
- function test, 19
- how to order parts, 8
- illustrated parts catalog, 7
- parts, 7
- parts, ordering, 8
- power board removal, 15
- precautions, 1
- preparation for disassembly, 9
- RC removal, 10
- rear components, 5
- removal
 - power board, 15
 - RC, 10
- removal and replacement procedures, 9
- returning to customer, 2
- RoHS (2002/95/EC) requirements, 2
- safety information, 1
- serial number location, 6
- service information, 1
- spare parts, 7
- support and troubleshooting, 19
- troubleshooting, 19