



Maintenance and Service Guide

E24q G5 model

SUMMARY

This guide provides information about spare parts, removal and replacement of parts, diagnostic tests, problem troubleshooting, and more.

© Copyright 2022 HP Development Company, L.P.

AMD is a trademark of Advanced Micro Devices, Inc. Bluetooth is a trademark owned by its proprietor and used by HP Inc. under license. NVIDIA is a trademark and/or registered trademark of NVIDIA Corporation in the U.S. and other countries. USB Type-C and USB-C are registered trademarks of USB Implementers Forum. DisplayPort and the DisplayPort logo are trademarks owned by the Video Electronics Standards Association (VESA) in the United States and other countries.

The information contained herein is subject to change without notice. The only warranties for HP products and services are set forth in the express warranty statements accompanying such products and services. Nothing herein should be construed as constituting an additional warranty. HP shall not be liable for technical or editorial errors or omissions contained herein.

First Edition: December 2022

Document Part Number: N22680-E24q G5-MSG-V1

Assembly part number: N22680-001

Product notice

Only trained service personnel familiar with this product should service it. Before performing any maintenance or service, be sure to read "Important Safety Information".

Table of Contents

1	Getting started.....	2
	Important safety information.....	2
	Important service information and precautions.....	2
	RoHS (2002/95/EC) requirements.....	3
	General descriptions.....	3
	Firmware updates.....	3
	Before returning the repaired product to the customer.....	3
2	Monitor features.....	4
	Features.....	4
	Front components.....	6
	Rear components.....	6
	Locating the serial number and product number.....	8
3	Illustrated parts catalog.....	9
	How to order parts.....	10
4	Removal and replacement procedures.....	12
	Preparation for disassembly.....	12
	Rear Cover.....	12
	Power board.....	16
	Connector repair.....	17
	HDMI connector CN502.....	18
	DP connector CN501.....	19
	USB3.0 (UP) connector CN105.....	20
	USB3.0 (1/2) connector CN106/CN104.....	20
	USB3.0 (3/4) connector CN1005/CN1004.....	21
	Function test.....	21
	Support and troubleshooting.....	22
	Index.....	24

1 Getting started

Read this chapter to learn about safety information and where to find additional HP resources.

Important safety information

Carefully read the cautions and notes within this document to minimize the risk of personal injury to service personnel. The cautions and notes are not exhaustive. Proper service methods are important to the safe, reliable operation of equipment. Improper service methods can damage equipment.

The service procedures recommended and described in this service manual provide effective methods of performing service operations. Service engineers should have prior repair knowledge and experience as well as appropriate training for the product before performing service procedures.

- Be sure your working environment is dry and clean and meets all government safety requirements.
- Be sure that other persons are safe while you are servicing the product.
- Do not perform any action that can cause a hazard to the customer or make the product unsafe.
- Use proper safety devices to ensure your personal safety.
- Always use approved tools and test equipment for servicing.
- Never assume the product's power is disconnected from the main power supply. Check that it is disconnected before opening the product's cabinet.
- Modules containing electrical components are sensitive to electrostatic discharge (ESD). Follow ESD safety procedures while handling these parts.
- Some products contain more than one battery. Do not disassemble or expose a battery to high temperatures, such as throwing into fire, or the battery may explode.
- Refer to government requirements for battery recycling or disposal.

This information provides general service information for the monitor. Adherence to the procedures and precautions is essential for proper service.

IMPORTANT: Only trained service personnel who are familiar with this HP product should perform service or maintenance for it. Before performing any service or maintenance, personnel must read the important safety information.

IMPORTANT: You must disconnect the power cord from the power source before opening the monitor to prevent component damage.

Important service information and precautions

- Repair must be performed by professional service technicians in a repair center. End users should not perform these procedures.
- Please note during servicing that the primary side is the high voltage area.
- This monitor meets ROHS requirements. Be sure to use lead-free solder wire when soldering.
- If you must change a capacitor, be sure to match the polarity as printed on the PCB.
- If you must replace a capacitor, make sure the specification and part number match the BOM and location.
- If you must replace a capacitor, insert new parts carefully to avoid a short circuit caused by the near pin.
- Do not get the board wet. Water and moisture can cause a short circuit that causes malfunctions.

- To avoid damage, be sure to use lead-free solder.
- When soldering, work quickly to avoid overheating the circuit board.
- Keep the soldering iron tip clean and well tinned when replacing parts.
- After repair, perform a close inspection of the circuit board to confirm it is in good condition.
- After repair, perform a function test to confirm the power supply is working properly.

ERP Lot5 requirement

1. A professional repairer must have the technical competence to repair electronic displays and comply with the applicable regulations for repairers of electrical equipment in the Member States where the repairer operates. Reference to an official registration system as professional repairer, where such a system exists in the Member States, shall be accepted as proof of compliance.

2. A professional repairer must have insurance that covers liabilities resulting from repairs, regardless of whether required by the Member State.

RoHS (2002/95/EC) requirements

Applied to all countries that require RoHS.

The RoHS (Restriction of Hazardous Substance in Electrical and Electronic Equipment Directive) is a legal requirement by the EU (European Union) for the global electronics industry sold in the EU and other countries. Any electrical and electronics products launched in the market after June 2006 should meet this RoHS requirement. Products launched in the market before June 2006 are not required to be compliant with RoHS parts. If the original parts are not RoHS compliant, the replacement parts can be non-ROHS compliant. If the original parts are RoHS compliant, the replacement parts **MUST** be RoHS compliant.

If product service or maintenance requires replacing parts, confirm the RoHS requirement before replacement.

General descriptions

This manual contains general information. There are two levels of service:

Level 1: Cosmetic/appearance/alignment service

Level 2: Circuit board or standard parts replacement

Firmware updates

Firmware updates for the monitor are available at support.hp.com. If no firmware is posted, the monitor does not need a firmware update.

Before returning the repaired product to the customer

Perform an AC leakage current check on exposed metallic parts to be sure the product is safe to operate without the potential of electrical shock. Do not use a line isolation transformer during this check.

Measurements that are not within specified limits present a possible shock hazard. You must check and repair the product before returning it to the customer.

2 Monitor features

This chapter provides an overview of the monitor's features.

Features

Depending on the model, your monitor might include the following features:

Display features

- 60.50cm (23.8 in), plus full-screen support for lower resolutions; includes custom scaling for maximum image size while preserving original aspect ratio
- True 8 bit (QHD only)
- sRGB 99%
- Antiglare panel with an LED backlight
- Touch screen capability (select products only)
- Ergonomic monitor setup guide (via the HP Display Center software) during first time use
- Tilt, swivel, height-adjustable, and pivot capabilities
- On-screen display (OSD) adjustments in several languages for easy setup and screen optimization
- Joypad OSD navigation
- Energy saver feature to meet requirements for reduced power consumption
- HP Eye Ease (TUV Low Blue Light Hardware Solution, certified and with a 75 Hz Max Refresh rate)
- Compatible with displays software including:
 - HP Display Center
 - HP Display Manager
- Secure firmware updates with HP Display Center
- Security cable slot on the rear of the monitor for an optional security cable
- Cable management feature for placement of cables and cords

Connectors

- DisplayPort™ video input
- High-Definition Multimedia Interface® (HDMI®) video input
- USB Type-B port
- USB Type-A port
- Plug and Play capability, if supported by your operating system

Monitor stand

- Removable stand for flexible monitor head mounting solutions
- VESA® mounting capability (100 × 100 mm) for attaching the monitor to a swing arm mount

NOTE: For safety and regulatory information, refer to the Product Notices provided on your optical disc or in

your documentation kit. To locate updates to the user guide for your product, go to <http://www.hp.com/support> and select your country. Select Find your product, and then follow the on-screen instructions.

Front components

To identify the components on the front of the monitor, use this illustration and table.

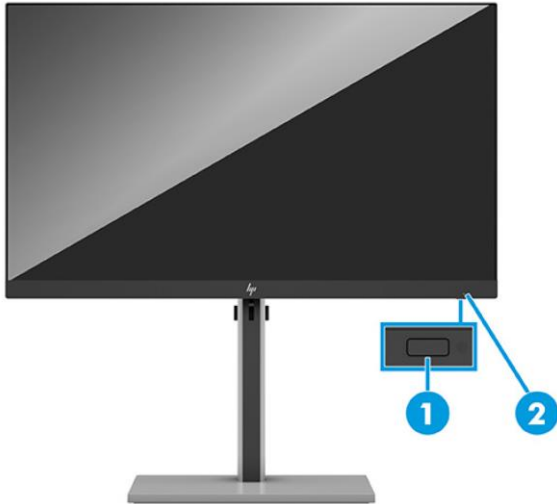

Table 1-1: Front components

Component	Function
1 Power button	Turns the monitor on or off.
2 Power LED	Indicates that the monitor is powered on.

Rear components

To identify the components on the rear of the monitor, use this illustration and table.

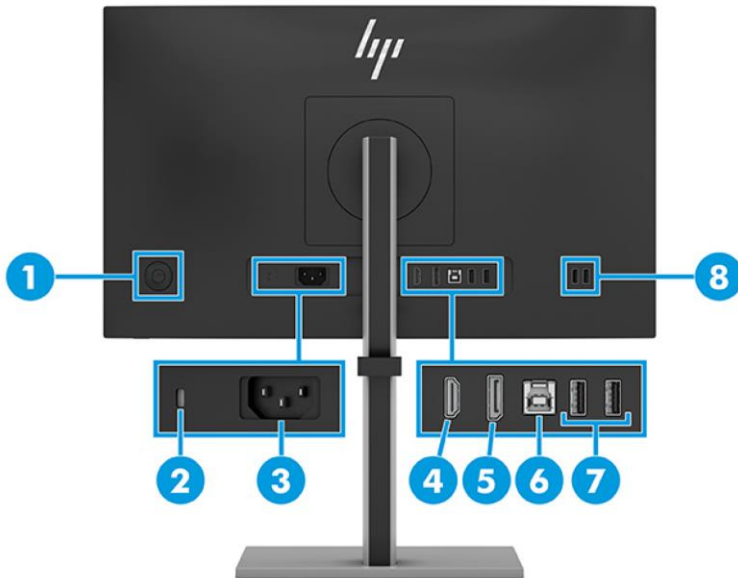

Table 1-2: Rear components

Component		Function
1	Joypad	Press to open the OSD settings.
2	Security cable slot	Connects an optional security cable.
3	Power connector	Connects a power cord.
4	HDMI port	Connects the HDMI cable to a source device such as a computer.
5	DisplayPort in connector	Connects the DisplayPort cable to a source device such as a computer.
6	USB Type-B port	Connects a USB Type-B to A cable Note: The USB hub is enabled only if the monitor is connected to the computer via a USB Type-B to A cable. Note: The touch screen function (select products only) is enabled only if the monitor is connected to the computer via a USB Type-B to A cable.
7	USB Type-A ports (2)	Connects a USB device, provides data transfer, and (for select products) charges small devices (such as a smartphone) when the computer is on or in Sleep mode. NOTE: Use a standard USB Type-A charging cable or cable adapter (purchased separately) when charging a small external device.
8	USB Type-A port (1), USB Type-A port with battery fast-charging 1.2 (1)	USB port: Connects a USB device, provides data transfer, and (for select products) charges small devices (such as a smartphone) when the computer is on or in Sleep mode. USB port with battery fast-charging 1.2 (5 V × 1.5 A = 7.5 W): Connects a USB device, provides high-speed data transfer, and charges small devices (such as a smartphone), even when the monitor is DC off with OSD performance mode on. NOTE: Use a standard USB Type-A charging cable or cable adapter (purchased separately) when charging a small external device.

Locating the serial number and product number

The label is located on the rear of the monitor. You may need these numbers when contacting HP about the monitor model.



For worldwide models

<p>HP 型号/型號: E24q G5 HP E24q G5 QHD Monitor 液晶显示器/液晶顯示器/모니터 60.5 cm (23.8") Monitor Regulatory Model No. / 規定型號 / 모델명: HSD-0149-A Input Rating/輸入电压 电流/輸入電壓 電流/ 정격입력: 100-240V ~ 1.6A (1.6A) 50/60Hz Made in China / 제조국: 중국 / 中国制造 / 中國製造</p>	<p>FC Apparätet må tilkoples jordet stikkontakt. Apparaten skall anslutas till jordat uttag. Laite on liitettävä suojakoskettimilla varustettuun pistorasiaan. Apparätets stikprop skal tilsluttes en stikkontakt med jord, som giver forbindelse til stikproppens jord.</p> <p>定格電壓 : 100V~ 定格電流 : 1.6A 定格周波數 : 50/60Hz</p>	<p>IS 13252 (Part 1)/ IEC 60950-1</p> <p>R-41069710 www.bis.gov.in</p> <p>UK CA HP Inc UK Ltd, Regulatory Enquiries, Earley West, 300 Thames Valley Park Drive, Reading, RG6 1PT</p> <p>XU100828-22117 R-R-hp-HSD-0149-A TPV Electronics (Fujian) Co., Ltd. 서비스센터 : 1588-3003</p>	<p>TÜVRheinland CERTIFIED</p> <p>GS</p> <p>PS E</p> <p>SAFETY MARK 220862-11</p> <p>NOM</p> <p>NYCE</p> <p>Low Blue Light (Hardware Solution) TÜVRheinland CERTIFIED www.tuv.com ID: 0217050412</p> <p>Assembly Part No. : N22680-001 Head Spares No. N24809-001/ASSY N22680-700</p>
<p>This device complies with part 15 of the FCC Rules. Nihon HP Operation is subject to the following two conditions: (1) This device may not cause harmful interference, and (2) this device must accept any interference received, including interference that may cause undesired operation.</p> <p>CAN ICES-003(B)/NMB-003(B) 警語: 使用過度恐傷害視力。</p>	<p>HDMI HIGH DEFINITION MULTIMEDIA INTERFACE</p>	<p>Image Quality ISO 9241-307 TÜVRheinland CERTIFIED www.tuv.com ID: 021705018</p> <p>TÜVRheinland CERTIFICADO www.tuv.com ID: 0000100000</p> <p>RSAS04 RoHS</p>	<p>EAC</p> <p>HP Inc.</p> <p>Product No. : 6N4F1AA Serial No. : CN4XX00001 Rev. XXXXXX Manufactured / 製造日期 / 製造日期: December 2022</p>

3 Illustrated parts catalog

To identify the monitor major components, use this illustration and table.

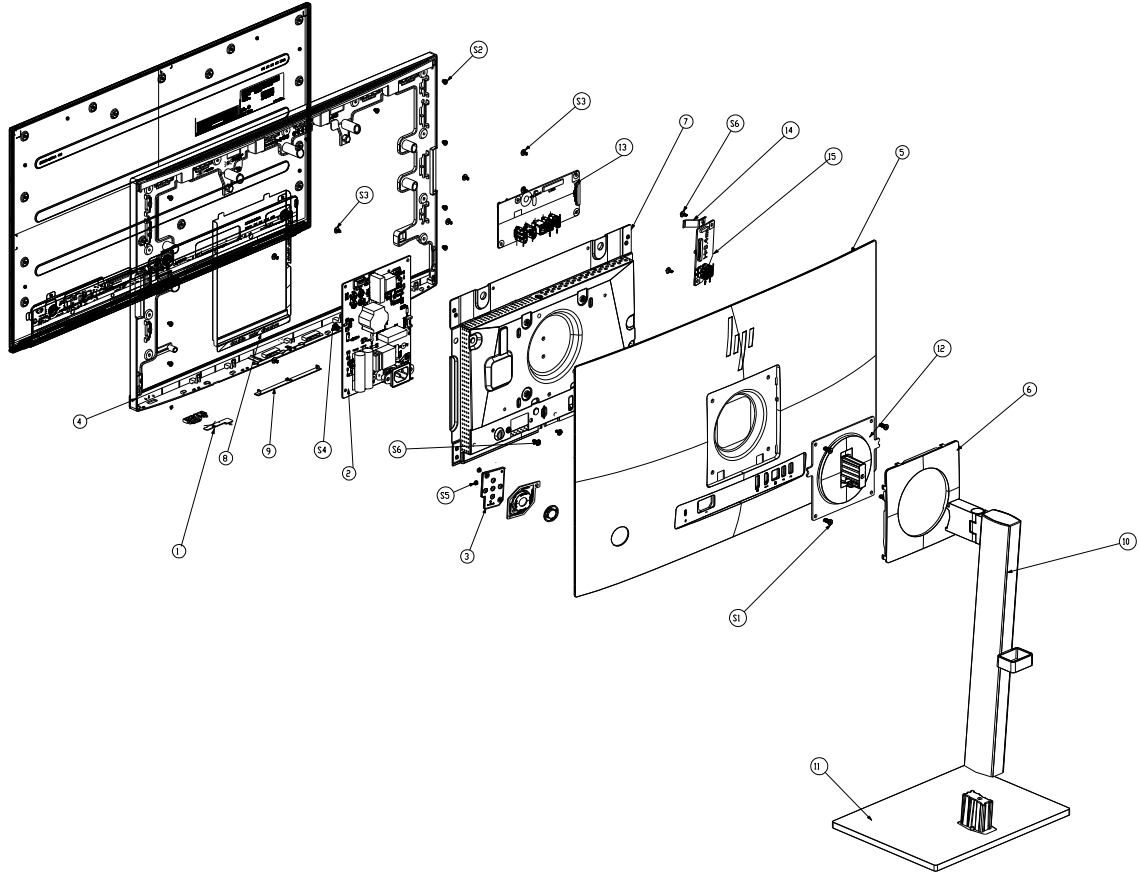

Item	Description	Qty
1	KEY BOARD	1
2	ADAPTER BOARD	1
3	Key Board	1
4	MIDDLE_FRAME	1
5	REAR_COVER	1
6	COVER_VESA	1
7	MAIN FRAME	1
8	INSULATING SHEET 188.17*132*9.5	1
9	COVER_SPK	1
10	stand ass'y N/A NA	1
11	BASE_ASS'Y N/A N/A	1
12	HINGE ASS"Y	1

13	MAIN BOARD	1
14	Spring Finger	2
15	USB BOARD	1
S1	QM1G088Z1002250AH1	4
S2	0M1G3030 4120	11
S3	0M1G1030 6120	7
S4	QM1G38400601200ARA	1
S5	QQ1G24200301200AWL	2
S6	0Q1G1030 6120	4

How to order parts

The HP authorized repair center can purchase the power board from HP.

Power board

Description	HP spare part number	Manufacturer part number
PSU E24q G5 (AUO)	N42815-001	PLPCME451AQAA
PSU E24q G5 (BOE)	N42816-001	PLPCME561KQA9
PSU E24q G5 (LGD)	N42817-001	PLPCME431GQA8

Capacitors and connectors are available for purchase from the following EU distributors

- RS Component: [Capacitors | RS Components \(rs-online.com\)](http://rs-online.com)

Capacitors by distributor

Component description	Location	Component distributor	Distributor part number
NA	NA	NA	NA

Connectors by manufacturer

Component description	Location identifier	Component distributor	Distributor part number
HDMI	CN502	NA	Contact HP Support
DP	CN501	NA	Contact HP Support
USB3.0-A	CN104/CN106	RS	10117836-002LF (Amphenol ICC)
USB 3.0-A	CN105	RS	692221030100 (Wurth Elektronik)
USB 3.0-A	CN1004/CN1005	RS	10117836-002LF (Amphenol ICC)

NOTE: Rear cover and chassis need to be modified to hold connector. Connector may need modifications to meet functional, safety and regulatory requirements accordingly if it doesn't match exactly.

You can purchase cables from the HP part store at <https://partsurfer.hp.com/Search.aspx>.

Internal and External Power Supplies are available for purchase from the following EU distributor: EET_ <https://www.eetgroup.com/en-eu/>

NOTE: HP continually improves and changes product parts. For complete and current information about supported parts for your product, go to <https://partsurfer.hp.com/Search.aspx>, select your country or region, and then follow the on-screen instructions.

4 Removal and replacement procedures

Adherence to these procedures and precautions is essential for proper service.

Preparation for disassembly

Use this information to properly prepare to disassemble and reassemble the monitor.

- 1) Read the “Important safety information” and “Important service information and precautions” sections in the “Getting started” chapter of this guide.
- 2) Clean the room for disassembly.
- 3) Identify the disassembly area.
- 4) Check the position that the monitors are to be placed along with the number of monitors. Prepare the area for material flow according to the disassembly layout.
- 5) Be sure to have the following equipment and materials:
 - Press fixture
 - Working table
 - Screwdriver
 - Knife
 - Gloves
 - Cleaning cloth
 - ESD protection
 - Scraper bar in the following dimensions:

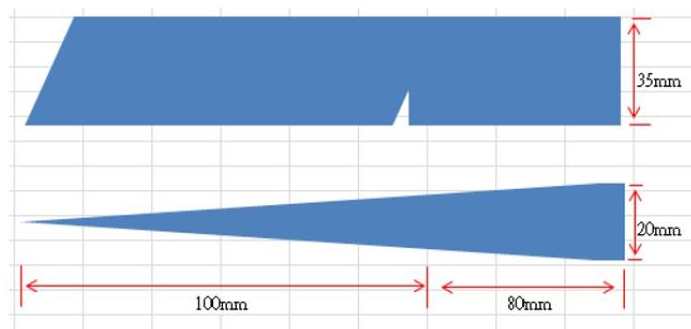

Rear Cover

Before removing the Rear Cover, follow these steps:

- ▲ Prepare the monitor for disassembly. See Preparation for disassembly on page 12.

Remove the Rear Cover:

- 1) Remove four screw from the hinge.



- 2) Use your fingers to split the left and right sides apart between the middle frame and rear case.

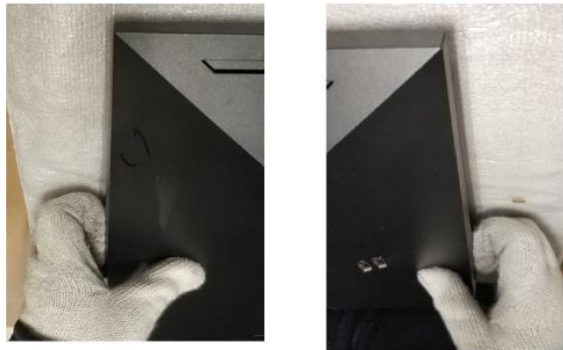

- 3) Insert the scraper bar tool into the gap between the middle frame and rear case, and then rotate. The hook opens. Repeat the steps.



- 4) Disassemble Rear Cover.



- 5) Remove the USB board wire from the Interface-board.

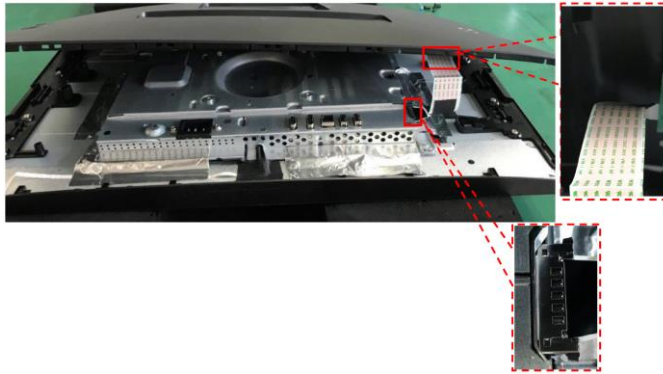

6) Disassemble the USB board and key board from the Rear Cover (if required).

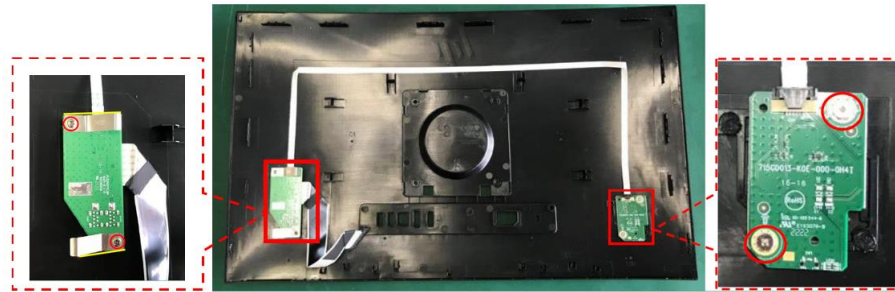

7) Remove the LED board.

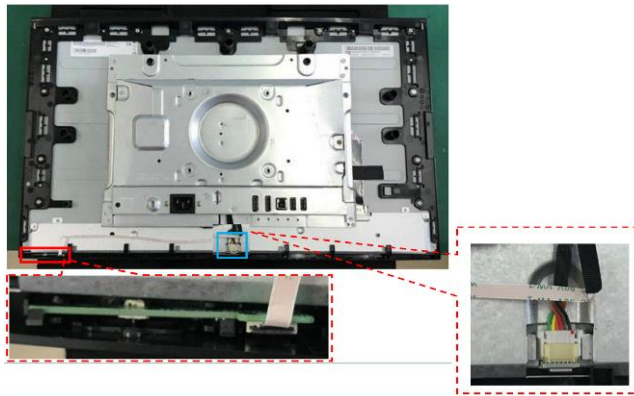

8) Remove the mylar. Tear off the tapes and disconnect the FFC cables to disassemble the main frame from panel

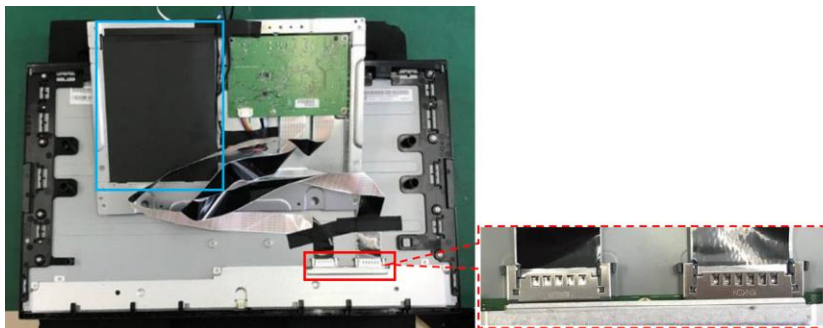

9) Tear off tapes and disassemble 8 screws from the board.

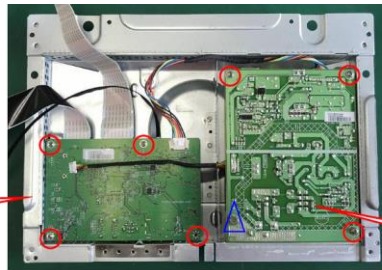
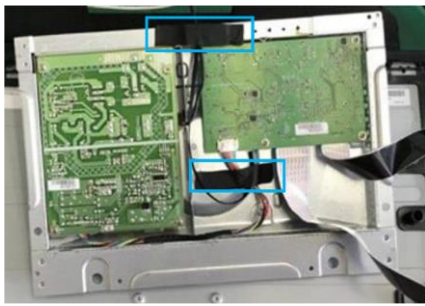

Main Board

Power Board

- 10) Disassemble all the boards from housing.
- 11) Disconnect all the wires from the board.

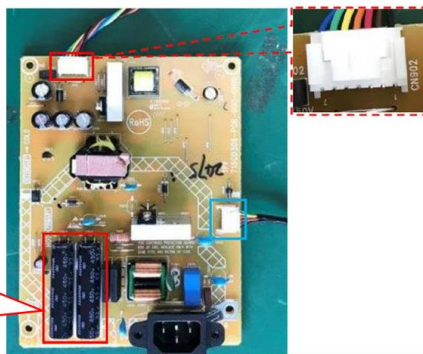
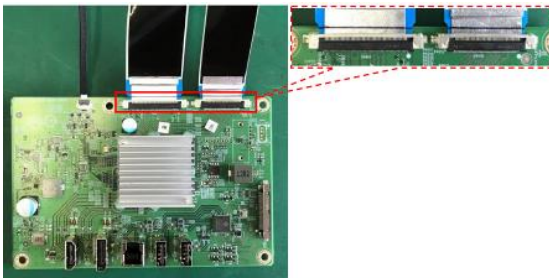
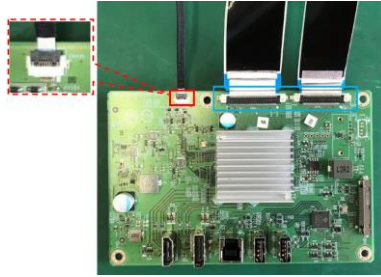
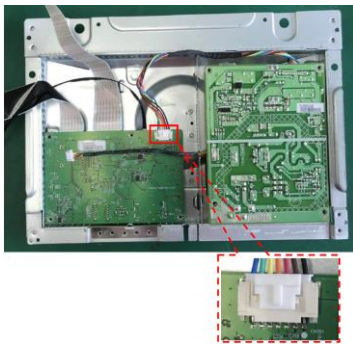

Capacitors greater than 2.5cm in diameter or height

- 12) Disassemble 11 screws to remove the middle frame and Panel.

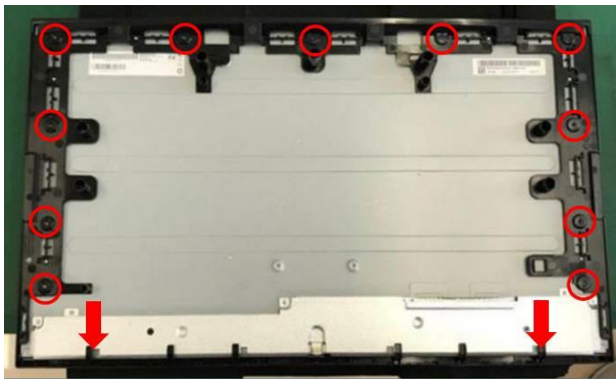

Power board

The power board part number is PLPCME451AQAA (AUO) or PLPCME561KQA9 (BOE) or PLPCME431GQA8 (LGD)

Before removing the power board, follow these steps:

- ▲ Prepare the monitor for disassembly. See Preparation for disassembly on page 12.

Remove the power board:

- 1) The HP E24q G5 power board connector position is as follows:

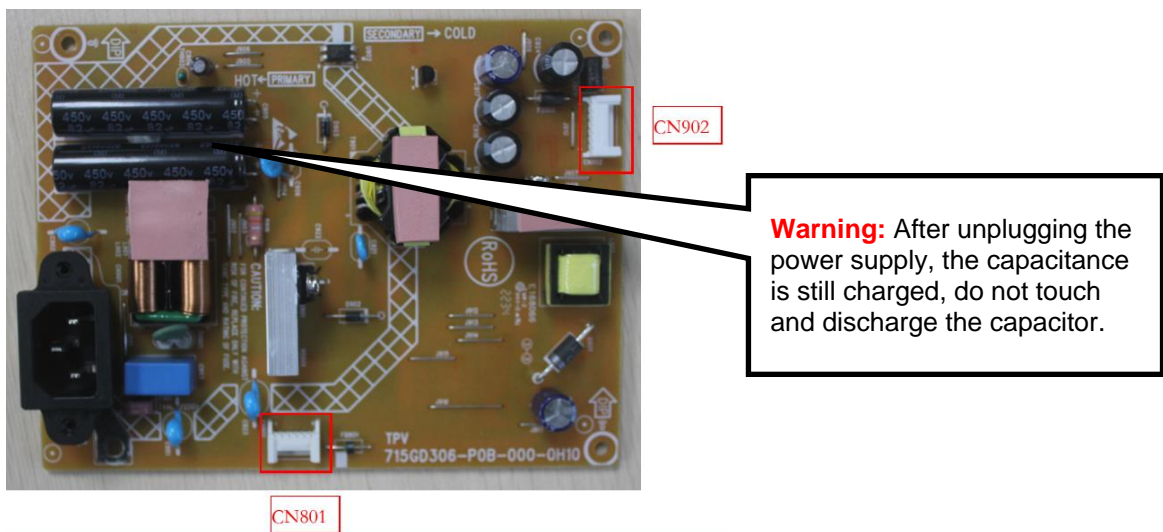

- 2) Locate the part number location on the board

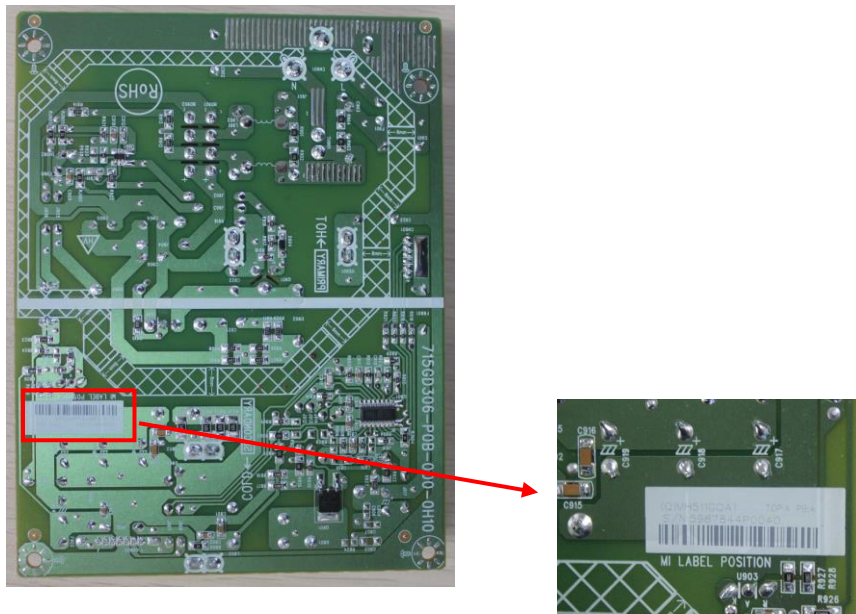

Connector repair

This procedure includes HDMI, DisplayPort, USB 3.0A connectors.

The connectors are on the main board (board part number CBPR2A6HPQ1)

The connectors' identifiers are as follows:

Connector	Location
HDMI	CN502
DP	CN501
USB3.0A(UP)	CN105
USB 3.0A(1/2)	CN106/ CN104

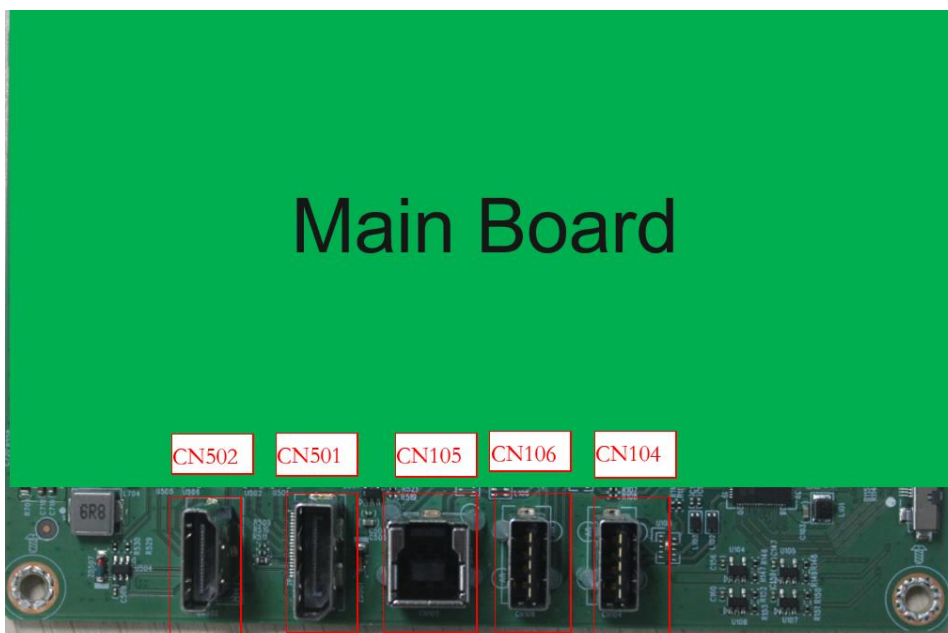

This procedure includes USB3.0 A connectors.

The connectors are on the USB board (board part number USB2QC2)

The connectors' identifiers are as follows:

Connector	Location
USB 3.0 A(3/4)	CN1005/CN1004



Before repairing connectors, follow these steps:

- ▲ Prepare the monitor for disassembly. See [Preparation for disassembly](#) on page 12.

IMPORTANT:

- **Repair Condition: Connector repair is only for out of warranty.**
- **Repairing must operate by professional repairers (Note) in repair center, not applicable for end user.**
- **Electrostatic protection is required when component replacement is required.**
- **The monitor meets ROHS, please use Lead-free solder wire for soldering.**
- **If Connector need to replace, must check specification and part number whether match the BOM and location.**
- **If connector need to replace, please insert new parts carefully because the near pin may cause short circuit by inappropriate operate.**
- **DO NOT allow any liquid on the board. Water and moisture may cause short-circuit to the electronic components and lead to malfunctions.**
- **The fusion point of Lead-Free solder is requested. Repairing with conventional lead wire may cause damage.**
- **Work quickly to avoid overheating the circuit board as soon as you confirm the steady soldering condition.**
- **Keep the soldering iron tip clean and well tinned and when replacing parts.**
- **A close inspection of the circuit board revealed look in good condition.**
- **After repaired, must connect source to each port to check Main board function is ordinary.**

Note: (The requirement of professional repairers' regulation by ERP lot5)

- 1) The professional repairer has the technical competence to repair electronic displays and complies with the applicable regulations for repairers of electrical equipment in the Member States where it operates. Reference to an official registration system as professional repairer, where such system exists in the Member States concerned, shall be accepted as proof of compliance with this point.
- 2) The professional repairer is covered by insurance covering liabilities resulting from its activity, regardless of whether this is required by the Member State.

HDMI connector CN502

Repair the HDMI connector:

- 1) Use a soldering iron and a de-soldering pump to remove as much solder as possible from the pin.

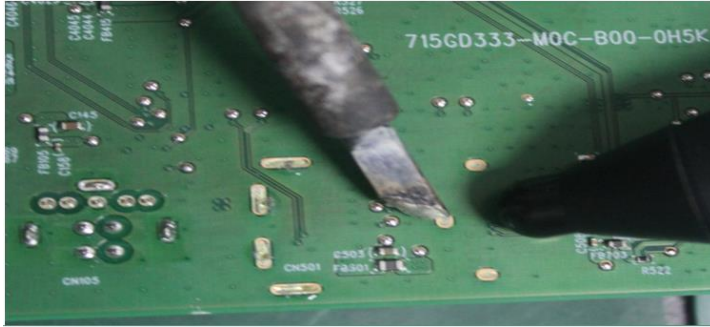

- 2) Use a hot air gun to melt the solder on the pins.

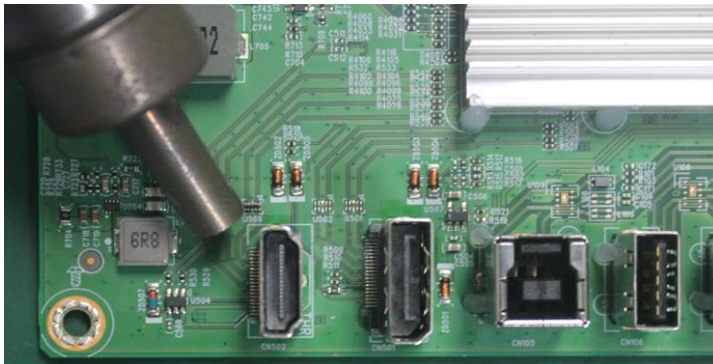

- 3) Lift the CN502 connector from the circuit board.
- 4) Place the new component on the circuit board. Be sure that it matches the footprint.
- 5) Solder the new component.

DP connector CN501

Repair the DP connector:

- 1) Use a soldering iron and a de-soldering pump to remove as much solder as possible from the pin.



- 2) Use a hot air gun to melt the solder on the pins.

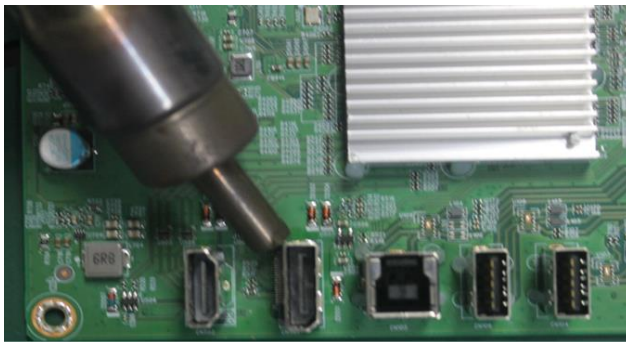

- 3) Lift the CN501 connector from the circuit board
- 4) Place the new component on the circuit board. Be sure that it matches the footprint.
- 5) Solder the new component.

USB3.0 (UP) connector CN105

Repair the USB3.0 (up) connector:

- 1) Use a soldering iron and a de-soldering pump to remove as much solder as possible from the pin.

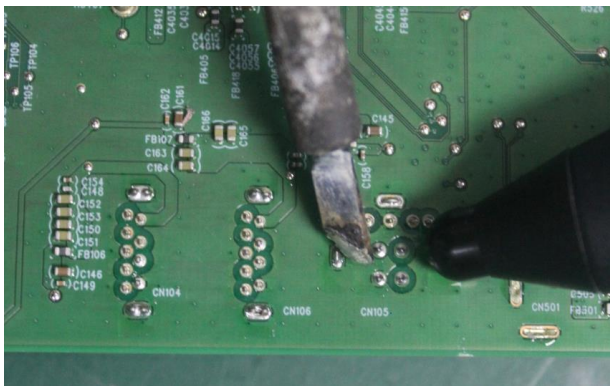

- 2) Lift the CN105 connector from the circuit board.
- 3) Place the new component on the circuit board. Be sure that it matches the footprint.
- 4) Solder the new component.

USB3.0 (1/2) connector CN106/CN104

Repair the USB3.0 (1/2) connector:

- 1) Use a soldering iron and a de-soldering pump to remove as much solder as possible from the pin.

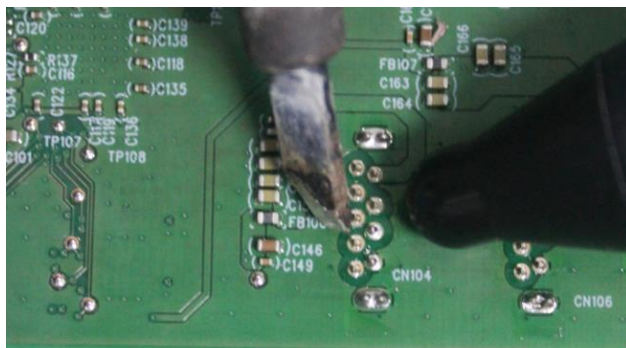

- 2) Lift the CN106/CN104 connector from the circuit board
- 3) Place the new component on the circuit board. Be sure that it matches the footprint.
- 4) Solder the new component.

USB3.0 (3/4) connector CN1005/CN1004

Repair the USB 3.0 connector:

- 1) Use a soldering iron and a de-soldering pump to remove as much solder as possible from the pin.

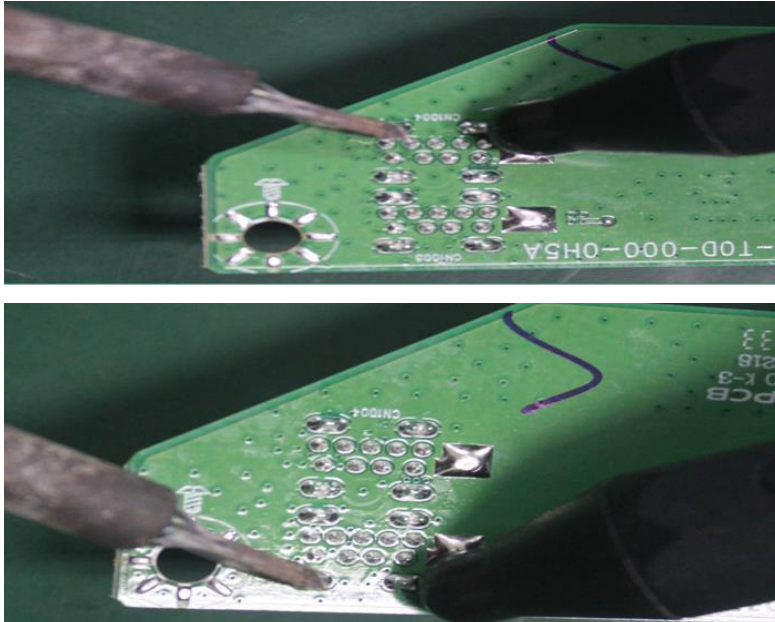

- 2) Lift the CN1005/CN1004 connector from the circuit board.
- 3) Place the new component on the circuit board. Be sure that it matches the footprint.
- 4) Solder the new component.

Function test

After repair, be sure to confirm that all functions are working.

Table 4-1: Function test

Test item	Operating description	Tool used
HDMI test	Confirm whether image displays and sound plays correctly on the monitor.	Computer or DVD player
DP test	Confirm whether image displays and sound plays correctly on the monitor.	Computer or DVD player

Support and troubleshooting

The following table lists possible problems, the possible cause or each problem, and the recommended solutions.

Problem	Possible cause	Solution
Screen is blank or video is flashing.	Power cord is disconnected.	Connect the power cord.
	Monitor is off.	Press the monitor power button. NOTE: If pressing the Power button has no effect, press and hold the power button for 10 seconds to disable the Power button lockout feature.
	Video cable is improperly connected.	Connect the video cable properly.
	System is in Auto-Sleep Mode.	Press any key on the keyboard or move the mouse to inactivate the screen blanking utility.
	Video card is incompatible.	Open the OSD menu and select the Input menu. Set Auto- Switch Input to Off and manually select the input. Or replace the video card or connect the video cable to one of the computer's on-board video sources.
Image appears blurred, indistinct, or too dark.	Brightness setting is too low.	Open the OSD menu and select Brightness to adjust the brightness scale as needed.
“Check Video Cable” is displayed on the screen.	Monitor video cable is disconnected.	Connect the appropriate video signal cable between the computer and monitor. Be sure that the computer power is off while connecting the video cable.
Input Signal Out of Range displayed on screen.	Video resolution and/or refresh rate are set higher than what the monitor supports.	Change the settings to a supported setting.
The monitor does not enter into a low-power sleep state.	The monitor's power saving control is disabled.	Open the OSD menu and select Power, select Auto-Sleep Mode, and then set auto-sleep to On.
Touch function is not working (select products only)	The touch screen function is enabled only if the USB Type-B port on the monitor is connected to the USB-Type-A port on the computer via a USB Type-B-to-A cable.	Connect the appropriate cables.
“OSD Lockout” is displayed	The monitor's OSD lockout function is enabled.	Press and hold the Left button for 10 seconds to disable the OSD Lockout function.
“Power Button Lockout” is displayed.	The monitor's Power Button Lockout feature is enabled.	Press and hold the Power button for 10 seconds to unlock the power button

Monitor has trouble waking from Sleep mode	function. DisplayPort inputs: Set the DisplayPort hot-plug detection to Always Active. Power mode monitors: Set the hot-plug detection to Always Active to switch the monitor to Performance mode.
--	--

Index

- components
 - front, 6
 - rear, 6
- connector repair, 17
- features, 4
- firmware updates, 3
- front components, 6
- function test, 21
- how to order parts, 10
- illustrated parts catalog, 9
- menu button location, 6
- parts, 9
- parts, ordering, 10
- power board removal, 16
- precautions, 2
- preparation for disassembly, 12
- RC removal, 12
- rear components, 6
- removal
 - power board, 16
 - RC, 12
- removal and replacement procedures, 12
- returning to customer, 3
- RoHS (2002/95/EC) requirements, 3
- safety information, 2
- serial number location, 8
- service information, 2
- spare parts, 9
- support and troubleshooting, 22
- troubleshooting, 22