

MODELS:

SRCOOLDXRW12, SRCOOLDXRW25

SmartRack® In-Row Precision Air Conditioning Units

FRONT VIEW

- A** Touchscreen
- B** Side Air Discharge

PIPING CONNECTIONS

- C** Main Electrical Input
- D** Outdoor Unit Electrical Input
- E** Signal Wiring Input
- F** Gas Pipe
- G** Liquid Pipe
- H** Accessory and Network Cable Access Port
- I** Water Drainpipe

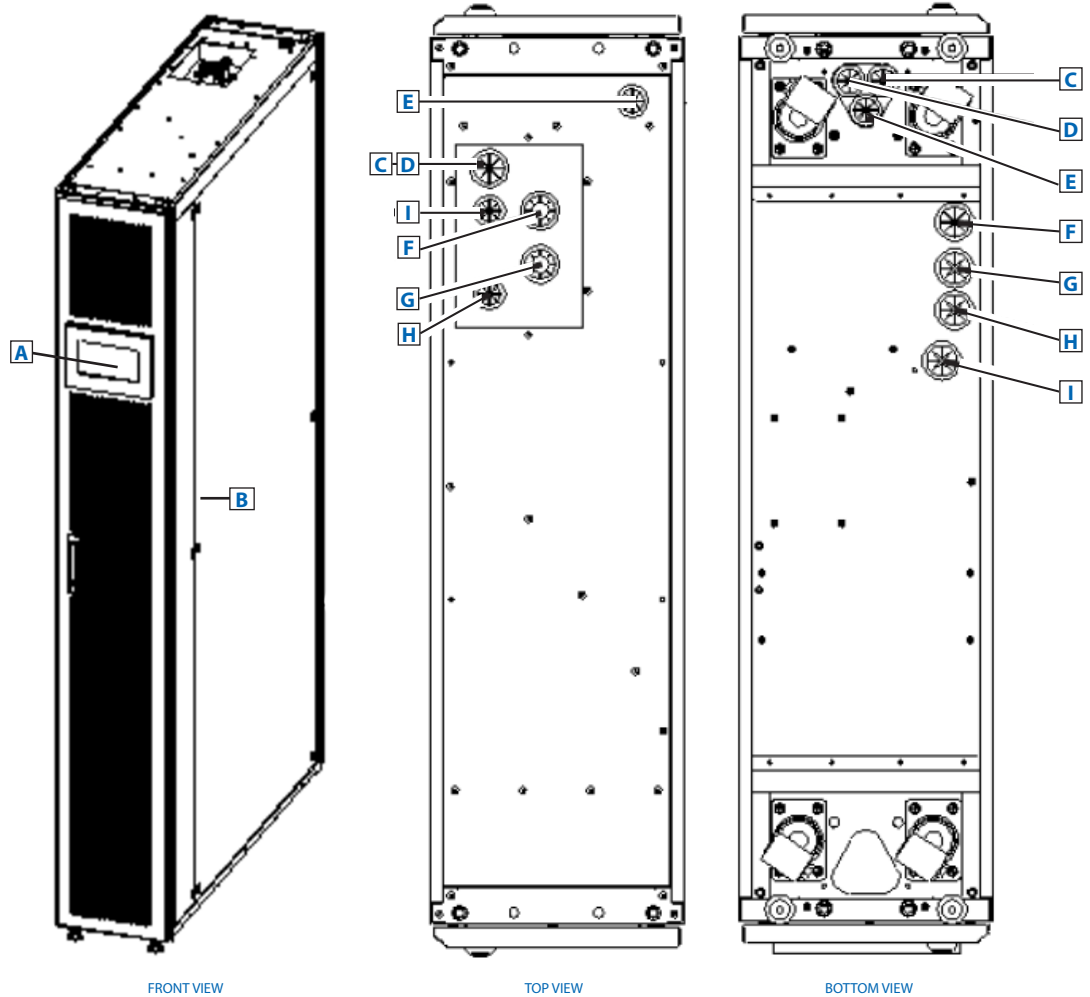

- Robust cooling in a space-saving footprint for your data center, IT room or other edge location
- Up to 85,000 BTU of cooling power
- Built-in casters all for easy expansion or movement as IT cooling needs change
- Pre-installed WEBCARDLX network interface offers 24/7 remote access

TRIPP-LITE
by **EATON**

Specifications

| Models | SRCOOLDXRW12 | SRCOOLDXRW25 |
|-----------------------------------|---|---|
| Model Includes | In-Row Cooler + External Condenser | In-Row Cooler + External Condenser |
| Rated Cooling Capacity | 12.8 kW (43,686 BTU/hr) | 25.8 kW (88,033 BTU) |
| Input Power | 208V, 3-Phase | 208V, 3-Phase |
| Min. Circuit Ampacity (MCA) | 19A | 33A |
| Max. Overcurrent Protection (MOP) | 25A | 50A |
| Frequency | 60 Hz | 60 Hz |
| Refrigerant Type | R410A | R410A |
| Input Power Cable (Phases) | 8 AWG 10 mm ² (0.02 in ²) | 8 AWG 10 mm ² (0.02 in ²) |
| Input Cable (Neutral & Ground) | 8 AWG 10 mm ² (0.02 in ²) | 8 AWG 10 mm ² (0.02 in ²) |
| Cable Fixation Torque | 1.5~1.8 N•m | 1.5~1.8 N•m |
| Unit Height | 2000 mm (78.7 in.); 42U | 2000 mm (78.7 in.); 42U |
| Unit Depth | 1100 mm (43.3 in.) | 1100 mm (43.3 in.) |
| Unit Width | 300 mm (11.8 in.) | 300 mm (11.8 in.) |
| Unit Weight | 180 kg (397 lb.) | 198 kg (437 lb.) |
| Unit Carton Weight | 215 kg (474 lb.) | 233 kg (514 lb.) |
| External Condenser Units | | |
| Input Power | 208V, 1-Phase | 208V, 3-Phase |
| Input Power Cable (Phases) | 16 AWG 1.5 mm ² (0.002 in. ²) | 16 AWG 1.5 mm ² (0.002 in. ²) |
| Input Power Cable (Neutral) | 16 AWG 1.5 mm ² (0.002 in. ²) | (No Neutral line) |
| Cable Fixation Torque | 0.6~0.8 N•m | Terminal: 0.6~0.8 N•m Breaker: 3.5~4 N•m |
| Unit Height | 1239 mm (48.78 in.) | 723 mm (28.46 in.) |
| Unit Depth | 425.1 mm (16.74 in.) | 997 mm (39.25 in.) |
| Unit Width | 800 mm (31.5 in.) | 1407 mm (55.39 in.) |
| Leg Height | N/A (Vertical Standing) | 452 mm (17.80 in.) |
| Unit Weight | 62 kg (136.6 lb.) | 87 kg (191.8 lb.) |
| Unit Carton Weight | 78 kg (172 lb.) | 120 kg (265 lb.) |

Models:

**SRCOOLDXRW12/
SRCOOLDXRW25**

TRIPP·LITE
by **EAT·N**

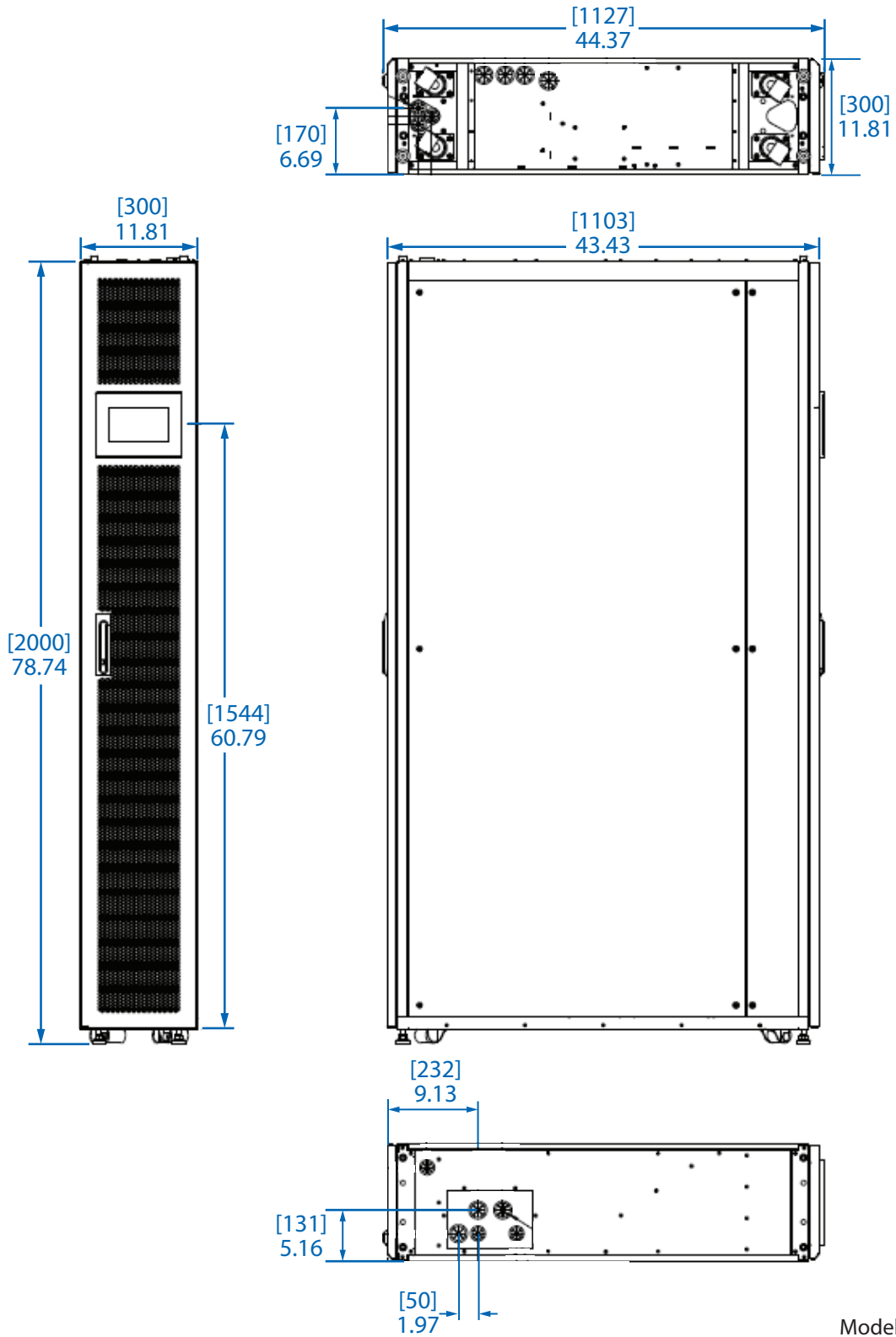

Models:
SRCOOLDXRW12/
SRCOOLDXRW25

TRIPP-LITE
 by **EAT·N**

Dimensions: [mm] inches

Outdoor unit for SRCOOLDXRW12

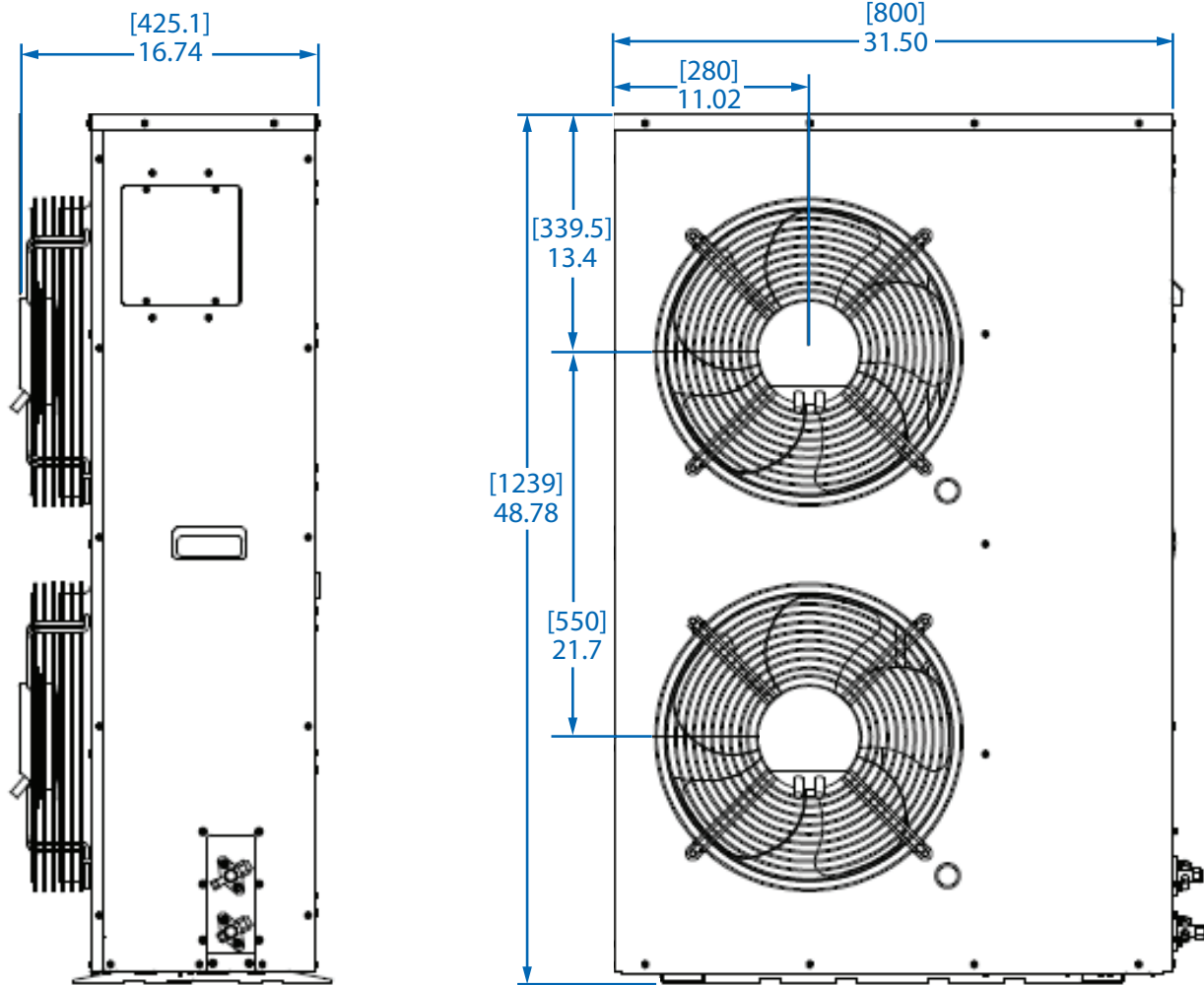

Dimensions: [mm] inches

Models:
**SRCOOLDXRW12/
SRCOOLDXRW25**

TRIPP·LITE
by **EAT·N**

Outdoor unit for SRCOOLDXRW25

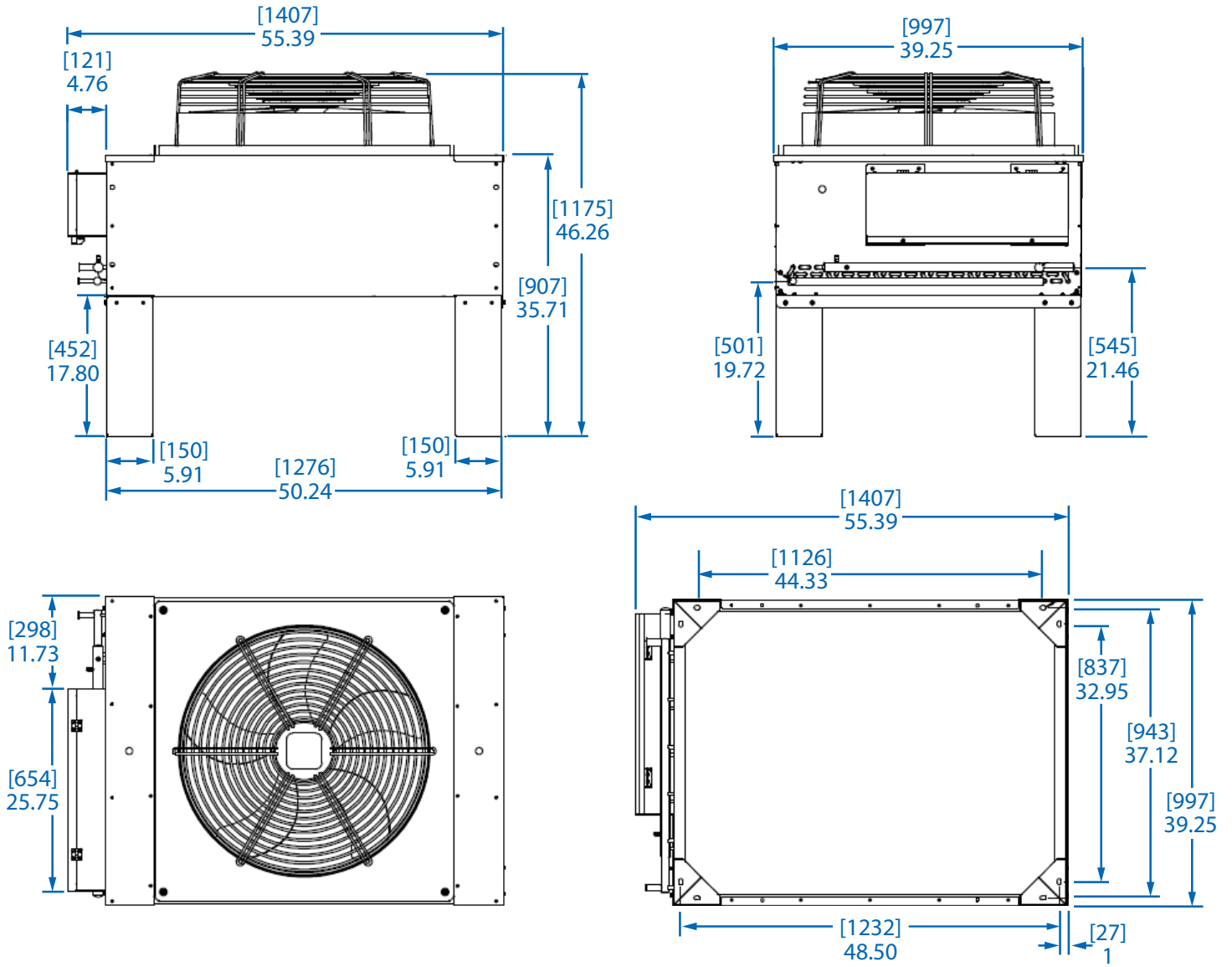

Dimensions: [mm] inches

Models:
SRCOOLDXRW12/
SRCOOLDXRW25

TRIPP·LITE
 by **FAT·N**

Clearance Requirements (Indoor Units)

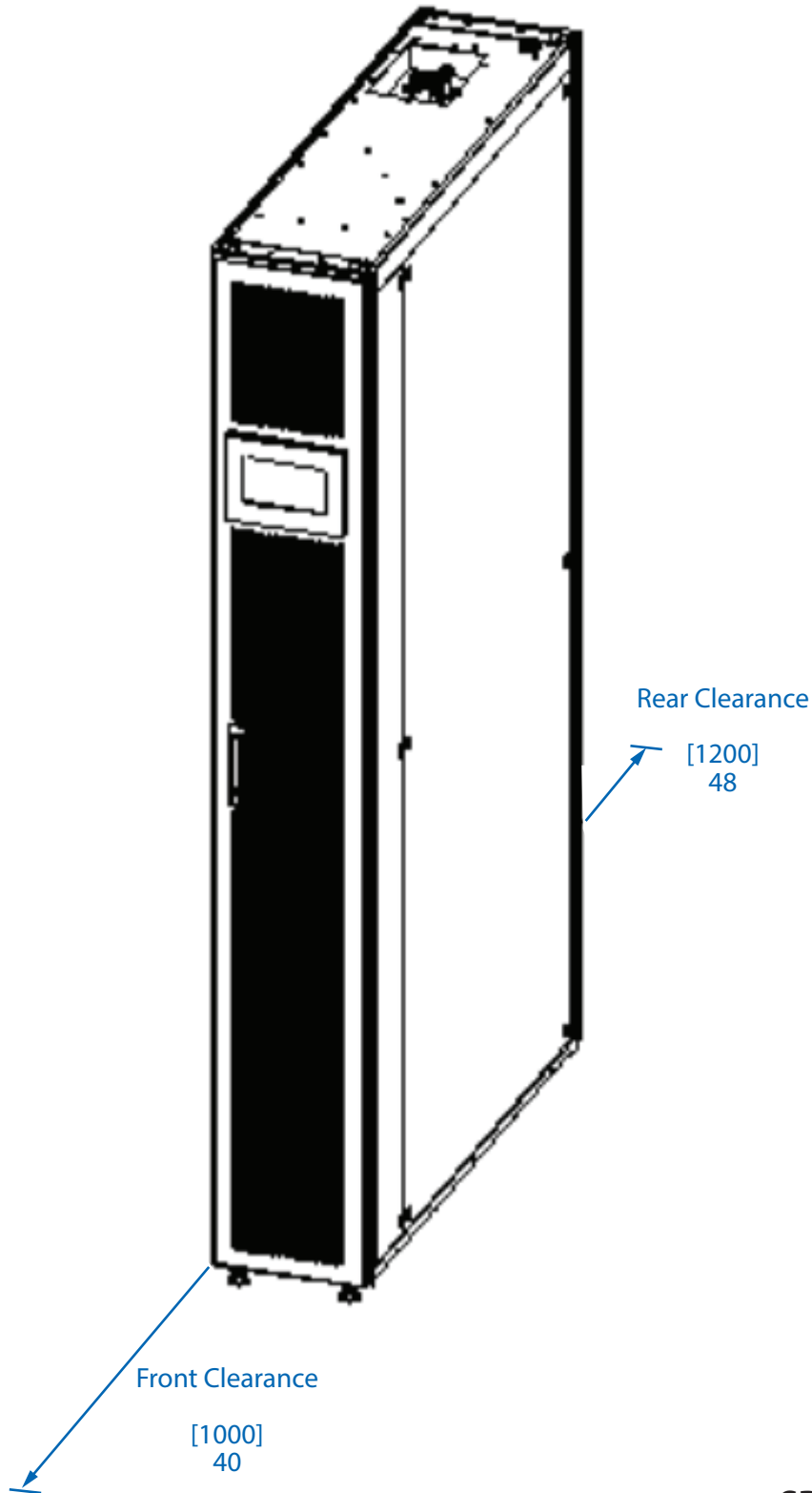

Dimensions: [mm] inches

Models:
**SRCOOLDXRW12/
SRCOOLDXRW25**

TRIPP·LITE
by **EAT·N**

Clearance Requirements, Outdoor Units

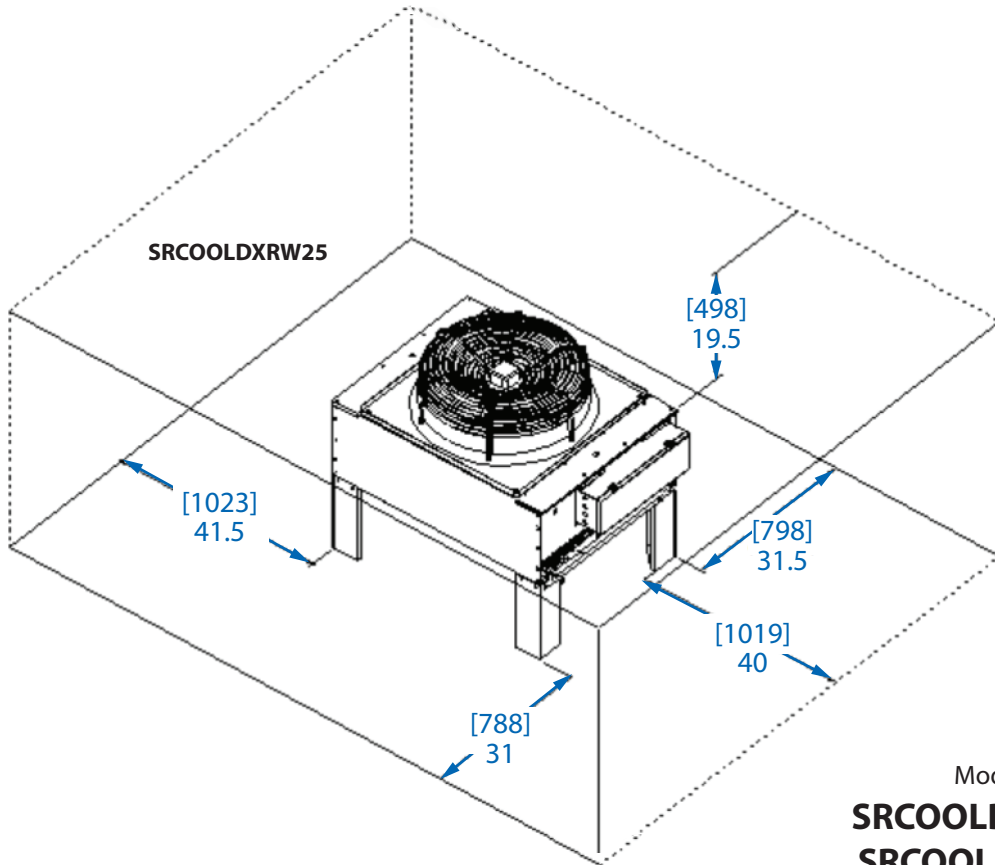
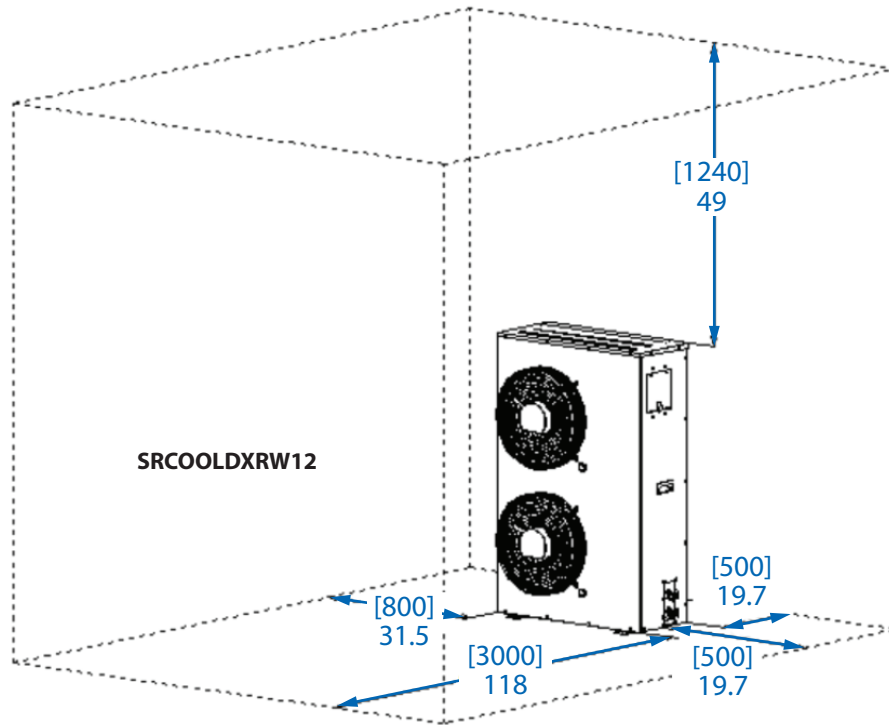

Models:
**SRCOOLDXRW12/
SRCOOLDXRW25**

TRIPP·LITE
by **EAT·N**

Dimensions: [mm] inches

Electrical Panel

SRCOOLDXRW12

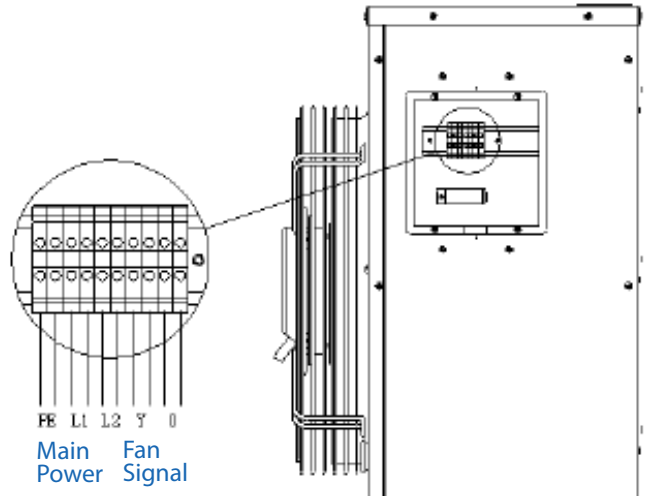
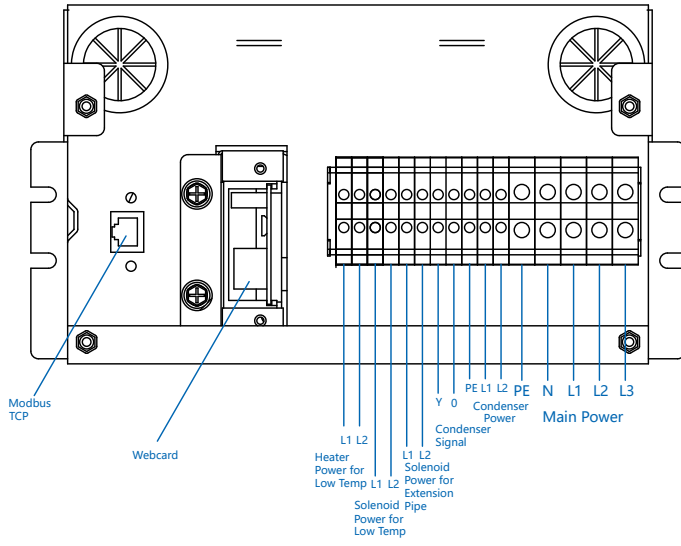

SRCOOLDXRW25

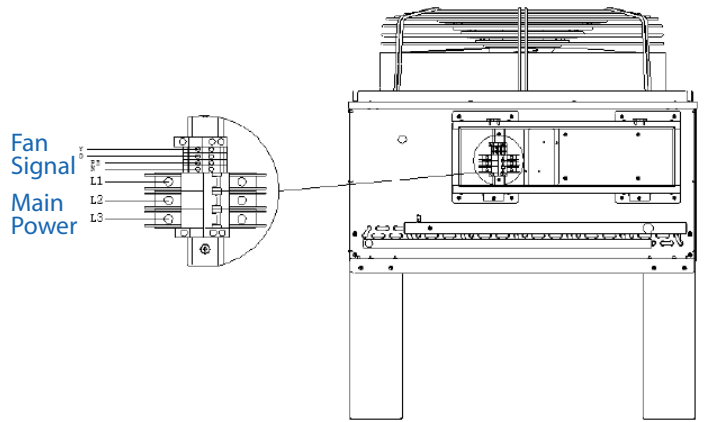
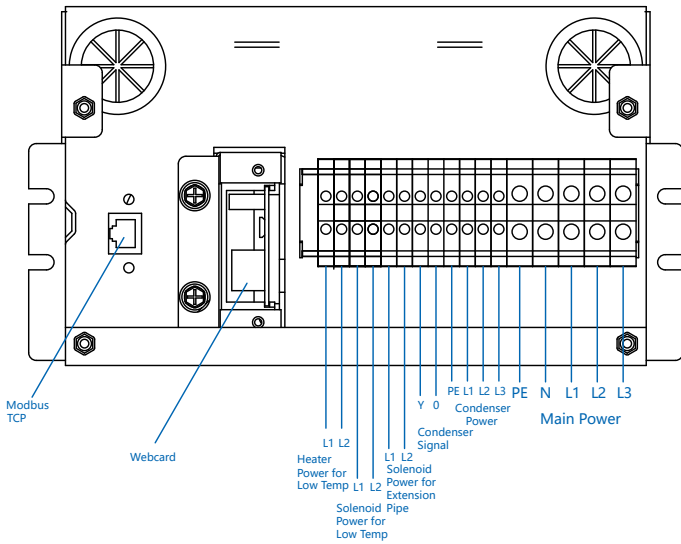

Models:
SRCOOLDXRW12/
SRCOOLDXRW25

TRIPP-LITE
 by **EAT·N**

Controller Diagram

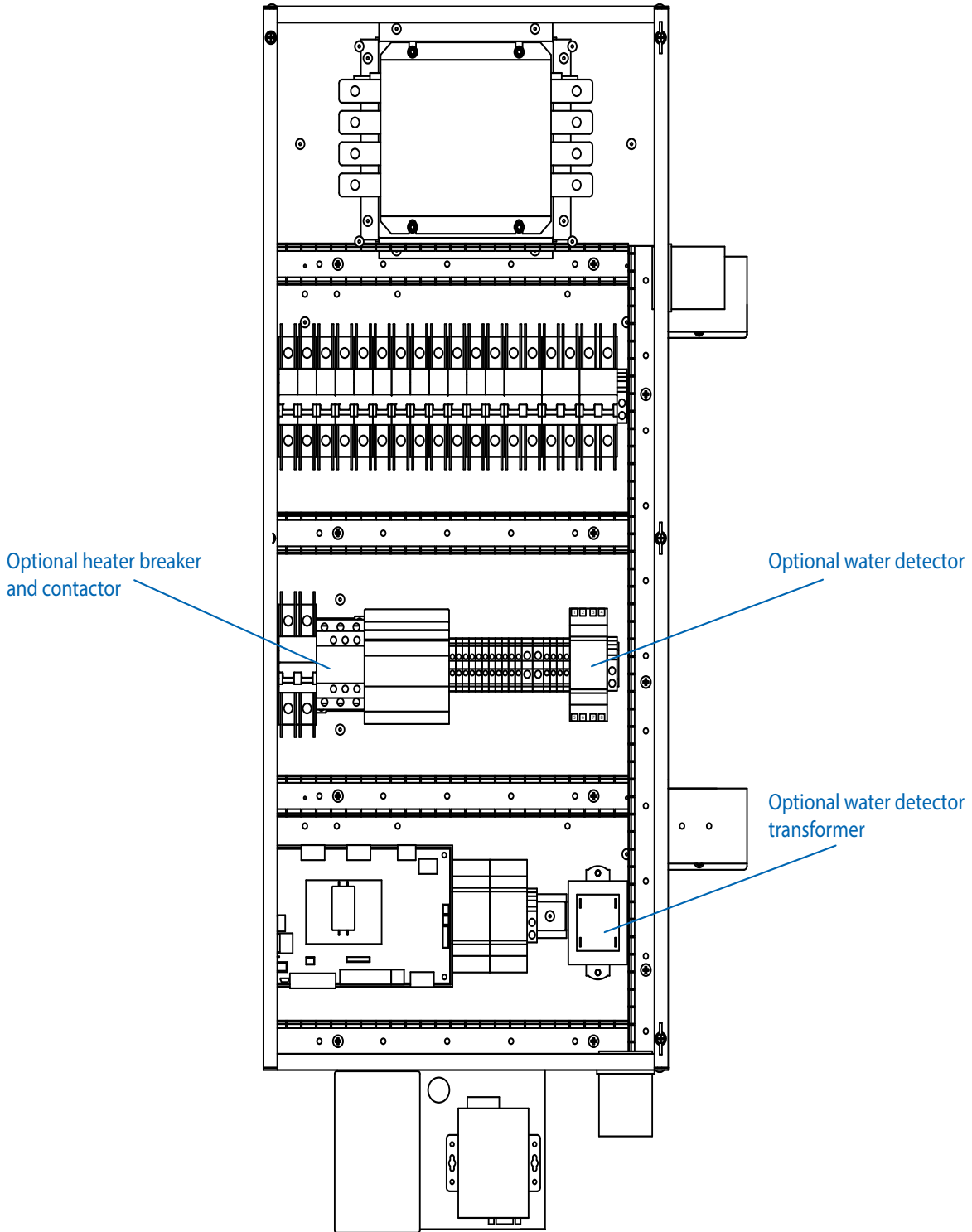

Models:
**SRCOOLDXRW12/
SRCOOLDXRW25**

TRIPP-LITE
by **EATON**

Placement Configuration

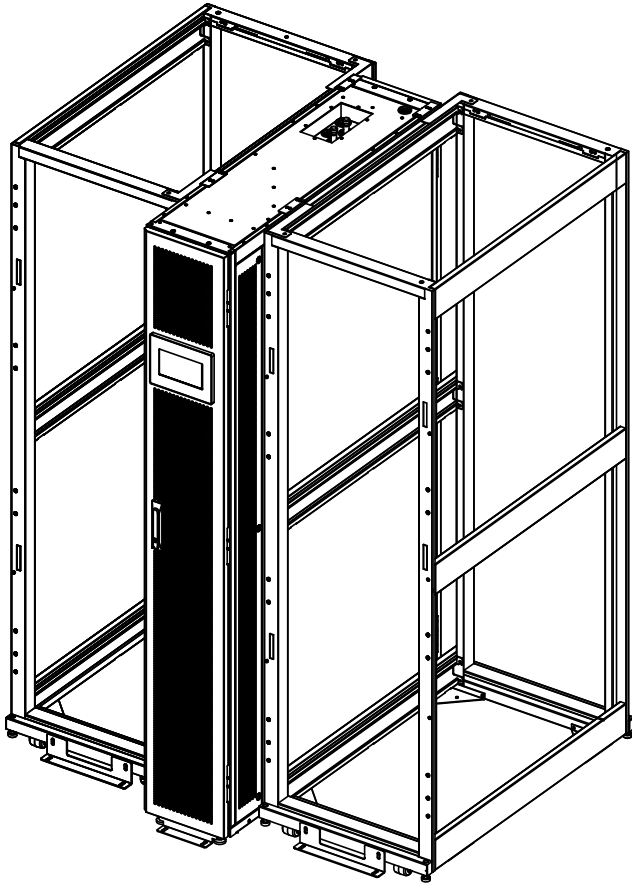

Protruded installation:
For side air discharge configuration

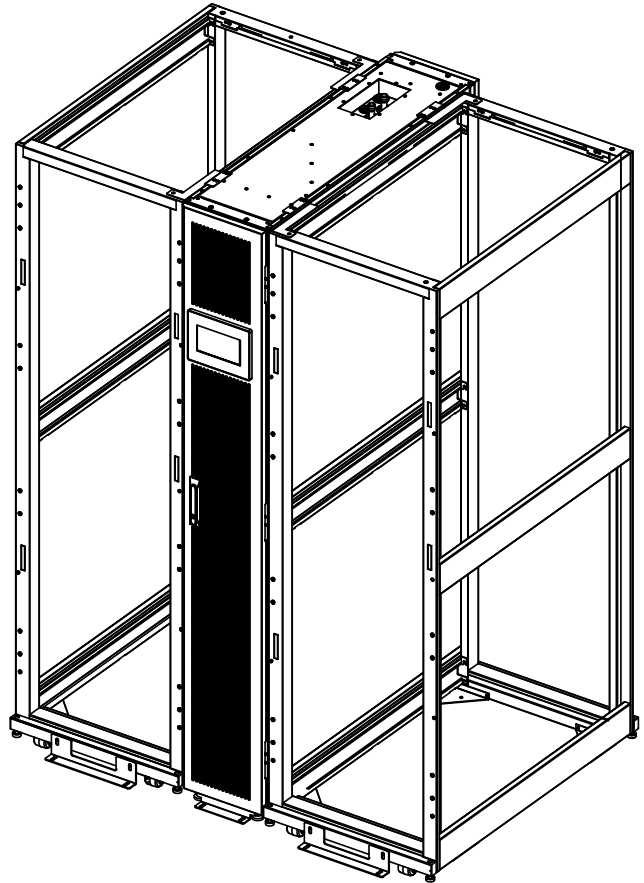

Flush installation:
For front air discharge configuration

Models:

**SRCOOLDXRW12/
SRCOOLDXRW25**

TRIPP·LITE
by **EAT·N**

1111 W. 35th Street
Chicago, IL 60609 USA
773.869.1234
tripplite.com

We have a policy of continuous improvement. Specifications are subject to change without notice.
Photos and illustrations may differ slightly from actual products.

About Tripp Lite by Eaton

Tripp Lite joined the Eaton family in March 2021. Eaton has long been a premier name in backup power and power management. The acquisition of Tripp Lite transforms Eaton's distributed IT infrastructure and connectivity equipment capabilities. Combining our product strengths and expert personnel allows us to offer comprehensive and innovative solutions for critical power and digital infrastructure applications, backed by quality, service and support you can trust. Learn more at tripplite.com/byEaton.