

TOSHIBA

POS PRINTER

Owner's Manual

TRST-L1 SERIES



⚠ WARNING!

This is a Class A product. In domestic environment, this product may cause radio interference in which user may be required to take adequate measures.

Changes or modifications not expressly approved by the manufacturer for compliance could void the User's authority to operate the equipment.

Supplier's Declaration of Conformity

This equipment has been tested and found to comply with the limits for a Class A digital device, pursuant to Part 15 of the FCC Rules. These limits are designed to provide reasonable protection against harmful interference when the equipment is operated in a commercial environment. This equipment generates, uses, and can radiate radio frequency energy and, if not installed and used in accordance with the instruction manual, may cause harmful interference to radio communications. Operations of this equipment in a residential area is likely to cause harmful interference in which case the user will be required to correct the interference at his own expense.

⚠ WARNING!

Changes or modifications made to this equipment, not expressly approved by TOSHIBA TEC or parties authorized by TOSHIBA TEC, could void the user's authority to operate the equipment.

Toshiba America Business Solutions, Inc.
25530 Commercentre Drive
Lake Forest, CA 92630
Tel: 949-462-6000

(for USA only)

Canada – Industry Canada (IC)

This device complies with Canada license-exempt RSS standard(s).

Operation is subject to the following two conditions:

- (1) this device may not cause interference, and
- (2) this device must accept any interference received, including interference that may cause undesired operation.

Any changes or modifications not expressly approved the grantee of the device could void the user's authority to operate the equipment.

Cet appareil est conforme avec industrie Canada exemptes de license RSS standard(s).

Son fonctionnement est soumis aux deux conditions suivantes:

- (1) cet appareil ne doit pas causer d'interference et
- (2) cet appareil doit accepter toute interference, notamment les interference qui peuvent affecter son fonctionnement.

Waste Recycling Information for Users:



This product is marked according to the requirement on Waste electrical and electronic equipment - WEEE.

The use of the symbol indicates that this product may not be disposed as unsorted municipal waste and has to be collected separately. By ensuring this product is disposed of correctly, you will help prevent potential negative consequences for the environment and human health, which could otherwise be caused by inappropriate waste handling of this product.

For more detailed information about the take-back and recycling of this product please contact your supplier where you purchased the product.

CE Compliance (for EU only)

This product is labelled with the CE mark in accordance with the provisions of the applicable European Directives, notably the Low Voltage Directive 2014/35/EU, the Electromagnetic Compatibility Directive 2014/30/EU, the RoHS Directive 2011/65/EU, (EU) 2015/863 for this product and electric accessories.

Safety Summary

Safety Summary

Personal safety in handling or maintaining the equipment is extremely important. Warnings and Cautions necessary for safe handling are included in this manual. All warnings and cautions contained in this manual should be read and understood before handling or maintaining the equipment.

Do not attempt to effect repairs or modifications to this equipment. If a fault occurs that cannot be rectified using the procedures described in this manual, turn off the power supply, unplug the machine, and then contact your authorized TOSHIBA TEC representative for assistance.

Meanings of Each Symbol



This symbol indicates warning items (including cautions). Specific warning contents are drawn inside the \triangle symbol. (The symbol on the left indicates a general caution.)



This symbol indicates prohibited actions (prohibited items). Specific prohibited contents are drawn inside or near the \odot symbol. (The symbol on the left indicates "no disassembling".)



This symbol indicates actions which must be performed. Specific instructions are drawn inside or near the \bullet symbol. (The symbol on the left indicates "disconnect the power cord plug from the outlet".)



WARNING

This indicates that there is the risk of **death** or **serious injury** if the machines are improperly handled contrary to this indication.



Any other than the specified AC voltage is prohibited.

Do not use voltages other than the voltage (AC) specified on the rating plate, as this may cause **fire** or **electric shock**.

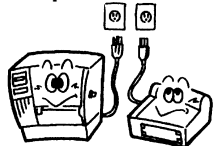

Prohibited

Do not plug in or unplug the power cord plug with wet hands as this may cause **electric shock**.

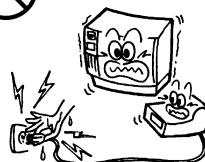

Prohibited

If the machines share the same outlet with any other electrical appliances which consume large amounts of power, the voltage will fluctuate widely each time these appliances operate. Be sure to provide an exclusive outlet for the machine as this may cause the machines to **malfunction**.



Prohibited

Do not place metal objects or water-filled containers such as flower vases, flower pots or mugs, etc. on top of the machines. If metal objects or spilled liquid enter the machines, this may cause **fire** or **electric shock**.



Prohibited

Do not insert or drop metal, flammable or other foreign objects into the machines through the ventilation slits, as this may cause **fire** or **electric shock**.

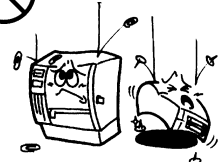

Prohibited

Do not scratch, damage or modify the power cords. Also, do not place heavy objects on, pull on, or excessively bend the cords, as this may cause **fire** or **electrical shock**.



Disconnect the plug.

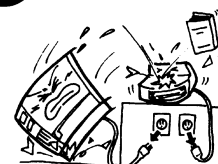

If the machines are dropped or their cabinets damaged, first turn off the power switches and disconnect the power cord plugs from the outlet, and then contact your authorized TOSHIBA TEC representative for assistance. Continued use of the machine in that condition may cause **fire** or **electric shock**.





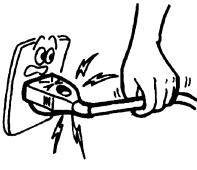

Disconnect the plug.

Continued use of the machines in an abnormal condition such as when the machines are producing smoke or strange smells may cause **fire** or **electric shock**. In these cases, immediately turn off the power switches and disconnect the power cord plugs from the outlet. Then, contact your authorized TOSHIBA TEC representative for assistance.



 <p>Disconnect the plug.</p> 	<p>If foreign objects (metal fragments, water, and liquids) enter the machines, first turn off the power switches and disconnect the power cord plugs from the outlet, and then contact your authorized TOSHIBA TEC representative for assistance. Continued use of the machine in that condition may cause fire or electric shock.</p>	 <p>Disconnect the plug.</p>  <p>When unplugging the power cords, be sure to hold and pull on the plug portion. Pulling on the cord portion may cut or expose the internal wires and cause fire or electric shock.</p>
--	---	---

 <p>Connect a grounding wire.</p> 	<p>Ensure that the equipment is properly grounded. Extension cables should also be grounded. Fire or electric shock could occur on improperly grounded equipment.</p>	 <p>No disassembling.</p>  <p>Do not remove covers, repair or modify the machine by yourself. You may be injured by high voltage, very hot parts or sharp edges inside the machine.</p>
---	---	---

 **CAUTION!** This indicates that there is the risk of personal **injury** or **damage** to objects if the machines are improperly handled contrary to this indication.

Precautions

The following precautions will help to ensure that this machine will continue to function correctly.

- Try to avoid locations that have the following adverse conditions:
 - * Temperatures out of the specification
 - * Direct sunlight
 - * High humidity
 - * Shared power source
 - * Excessive vibration
 - * Dust/Gas
- The cover should be cleaned by wiping with a dry cloth or a cloth slightly dampened with a mild detergent solution. **NEVER USE THINNER OR ANY OTHER VOLATILE SOLVENT** on the plastic covers.
- **USE ONLY TOSHIBA TEC SPECIFIED** paper.
- **DO NOT STORE** the paper where they might be exposed to direct sunlight, high temperatures, high humidity, dust, or gas.
- Ensure the printer is operated on a level surface.
- Any data stored in the memory of the printer could be lost during a printer fault.
- Try to avoid using this equipment on the same power supply as high voltage equipment or equipment likely to cause mains interference.
- Unplug the machine whenever you are working inside it or cleaning it.
- Keep your work environment static free.
- Do not place heavy objects on top of the machines, as these items may become unbalanced and fall causing **injury**.
- Take precautions not to injure your fingers by the manual cutter.
 - When remove printed paper.
 - When perform other operation such as loading /replacing paper roll.
- Do not lean against the machine. It may fall on you and could cause **injury**.
- Care must be taken not to injure yourself with the printer paper cutter.
- Unplug the machine when it is not used for a long period of time.

GENERAL PRODUCT INFORMATION

Product Description:

The subject model is a Class III POS Printer and can be powered by a certified external power supply, which the output was 24V $\overline{\text{---}}$, 2.5A max. and complied to the limited power source requirement as per clause 2.5 of IEC 60950-1:2005/A2:2013 or Annex Q of IEC 62368-1:2014, Alternately, the POS printer can be powered by the dedicated point of sale (POS) terminal, which the POS terminal's output was rated 24V $\overline{\text{---}}$, 2.3A max (include single fault) and classified as PS3 circuits and Resistive PIS as per clauses 6.2.2 and 6.2.3 of IEC 62368-1:2014 respectively

Y-cable will be provided for both the external power supply and POS terminal are connected to the POS printer. The Y-cable shall be rated at 24V Vdc, 2.3A, 50°C & VW-1 when used in the end installation.

The maximum ambient temperature specified by manufacturer was 40°C when powered by external power supply (Type reference: FSP060-RAAK3) and 50°C when powered by POS terminal. 24V, 2.3A max.

Important Information to the User

In order to ensure compliance with the Product Safety, FCC marking requirements, you must use the power supply, power cord, and interface cable which were shipped with this product or which meet the following parameters:

Power Adapter

The power adapter is required to comply with the safety and/or EMC requirements depending on the county where the equipment is used, and to have the following electrical characteristics, Class 1 power adapter with SELV (Secondary Extra Low Voltage) and L.P.S (Limited Power Source), non-energy hazard output, input rated 100-240 Vac, 1.8A Max, 50/60 Hz, output rated 24 Vdc, 2.5A. For the finest, please use TOSHIBA TEC recommended power adapter.

Interface Cable

You are advised to use a shielded (360 degree) interface cable with this product. The shield must be connected to the frame or earth ground connection or earth ground reference at BOTH ends of the cable. If another cable is used than described above you will need to test this cable with the TOSHIBA TEC printer and your system for local EMC requirements where the equipment is used.

Power Cord

For this product a UL listed, detachable power cord is required. When the power supply is mounted on the floor, a power cord with Type SJT marking is required. If a power cord is used different from described above, you might violate safety certifications which are in force in the country of use. The socket-outlet needs to be installed near the equipment and must be easily accessible.

Caution Label Information / Informations sur l'étiquette d'avertissement



Hot surface, Do not touch / Surface chaude, Ne pas toucher



Hazardous Moving Parts, Keep Fingers and Other Body Parts Away/ Parties Mobiles
Dangereuses Tenir Les Doigts Et Les Autres Parties Du Corps Éloignés.

Power Cord

As the power cord is not supplied with this printer, locally purchase the power cord that meets the following standard.

For USA and Canada:

Power Cord – UL and CSA approved, type SVT, 18/3AWG, rated min. 125V, 10A

Attached Plug and Appliance Coupler – UL and CSA approved, molded on type.

The plug is parallel-blade grounding type, NEMA 5-15P configuration. The appliance coupler is Female configuration.

Both attachment plug and appliance coupler are rated minimum 125V, 10A.

For European countries:

Power Supply Cord – HAR or domestic approved where the equipment is used,

Type H05VV-F, rated minimum 250V, 10A.

Attachment Plug and Appliance Coupler – Domestic approved where the equipment is used, molded on type, having grounding terminal rated minimum 250V, 10A. The appliance coupler is Female configuration.

Unpacking

1. Open the carton.
2. Remove the POS printer and **cushion** out from the carton.
3. Check the content and make sure no missing parts.
4. Place the POS printer on a level surface and make sure no physical damage.



POS Printer



Carton

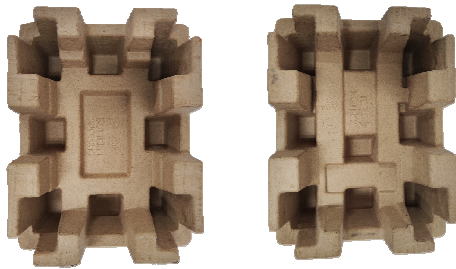

Paper Pulp

NOTE: *Keep the original carton and cushion for future transportation of the POS printer.*

TABLE OF CONTENTS

1. PRODUCT OVERVIEW.....	1
1.1 Introduction.....	1
1.2 Features	1
1.3 Applicable Model.....	2
1.4 Accessories	3
2. SPECIFICATIONS.....	4
2.1 General.....	4
2.2 Environmental usage conditions.....	7
2.3 Internal buffers.....	8
2.4 Thermal head basic performance.....	8
2.5 Main Card	8
2.6 Option Interface Card	8
2.7 Reliability (TRST-L1)	9
2.7.1 Life.....	9
2.7.2 Life MTBF (MCFB).....	9
2.8 Options.....	10
2.9 Receipt Roll	11
3. APPEARANCE	13
3.1 Front/Rear View.....	13
3.2 LED and Feed Button	13
3.3 Connectors	14
3.4 Specification of Interface & Power Connector.....	15
3.4.1 RS232C Interface.....	15
3.4.2 Ethernet Interface.....	15
3.4.3 USB Interface.....	16
3.4.4 Power Cable Connector	16
3.4.5 Cash Drawer Connector and Pin Assignments	17
4. SET UP PROCEDURE.....	18
4.1 Requirements for Operation.....	18
4.2 Setting up the Printer	19
4.3 Turning off the Printer	19
5. INSTALLATION PROCEDURE.....	20
5.1 Connecting the Power Cord and Interface Cable.....	21
5.1.1 Connect to Power Adapter.....	21
5.1.2 Connect via standard USB Type-B Cable	21
5.1.3 Connect via Option Card (RS232C & LAN).....	22
5.1.4 Connect via Y-Cable.....	23
5.1.5 Connecting via Cash Drawer	23
5.1.6 Interface cable to POS terminal connection position.....	24
5.2 Choosing a Location	25
5.3 Loading the Paper Roll	28
5.4 Changing Paper Guiding Width.....	30
5.5 Black Mark Sensor Configuration	31
5.6 Paper Damper Configuration	32
5.7 Minimum Paper Print Length	32
6. DIAGNOSTICS.....	33
6.1 Offline Diagnostic.....	33
6.2 Main Menu.....	33
6.3 Sub Menu	34
6.3.1 Setting Menu.....	36

6.3.2 Final Confirmation Menu	36
6.4 Printer Configuration Form.....	37
6.5 Paper Setting	39
6.5.1 Media Type	39
6.5.2 Paper Type	39
6.5.3 Paper Mode	40
6.5.4 Paper Width	40
6.5.5 Paper Low Detection.....	40
6.6 Printer Maintenance	40
6.6.1 Printer Maintenance QR	40
6.6.2 Cleaning Setting.....	41
6.7 Other Software Setting.....	41
7. GENERAL MAINTENANCE.....	43
7.1 Cleaning the Covers	43
7.2 Cleaning Mode.....	43
8. TROUBLESHOOTING.....	45
8.1 Removing Jammed Paper	45
8.2 Resetting Cutter Failure or Jam	45
8.3 Common Problems & Solutions	47
8.4 LED Indication Table	49
9. APPENDIX A.....	51
9.1 Ethernet	51
9.2 Password Registration.....	51
9.3 Web Setting Page.....	52
9.4 Reset Password	53
10. APPENDIX B	54
10.1 Reference List of Tested Linerless Paper	54
10.2 Reference List of Tested Receipt Paper.....	55
10.3 Reference List of Tested Label Paper	55
11. APPENDIX C	56
11.1 Black Mark Specification	56
12. APPENDIX D.....	57
12.1 Liner Label Specification.....	57



CAUTION!

1. This manual may not be copied in whole or in part without prior written permission of TOSHIBA TEC.
2. The contents of this manual may be changed without notification.
3. Please refer to your local authorized service representative with regard to any queries you may have in this manual.

1. PRODUCT OVERVIEW

1.1 Introduction

Thank you for purchasing the TOSHIBA TEC TRST-L1 Series POS Printer. This product is a single station POS printer, which consists a thermal head for one side printing. Base model includes 32bit CPU architecture with Flash ROM, Cash Drawer Connector, Mini-DIN Power, USB Type A and Type B connector. The interface used is USB I/F, and RS232C I/F or Ethernet I/F as option.

This manual contains general set-up and maintenance information and should be read carefully to help gain the maximum performance and life from your printer. For most queries please refer to this manual and keep it safe for future reference.

1.2 Features

- Printer Speed:
 - Receipt mode : Max 203mm/sec or 8ips
 - Linerless mode : Max 203mm/sec or 8ips
 - Label mode : Max 203mm/sec or 8ips
- Drop-in paper loading
- Paper out sensor
- Paper removal sensor
- Black mark sensor
- Label gap sensor
- Paper low detection sensor
- Build-in adjustable paper guide, support up to 3 types of width (40mm, 58mm, 80mm)
- Supported paper type: Receipt/Linerless paper/Label paper
- Large LED & loud audio notification
- Knife: Selectable between Full and Partial cut (Default: Partial Cut)
- Support vertical, horizontal and wall mount (90°)

1. PRODUCT OVERVIEW

1.3 Applicable Model

Model name description

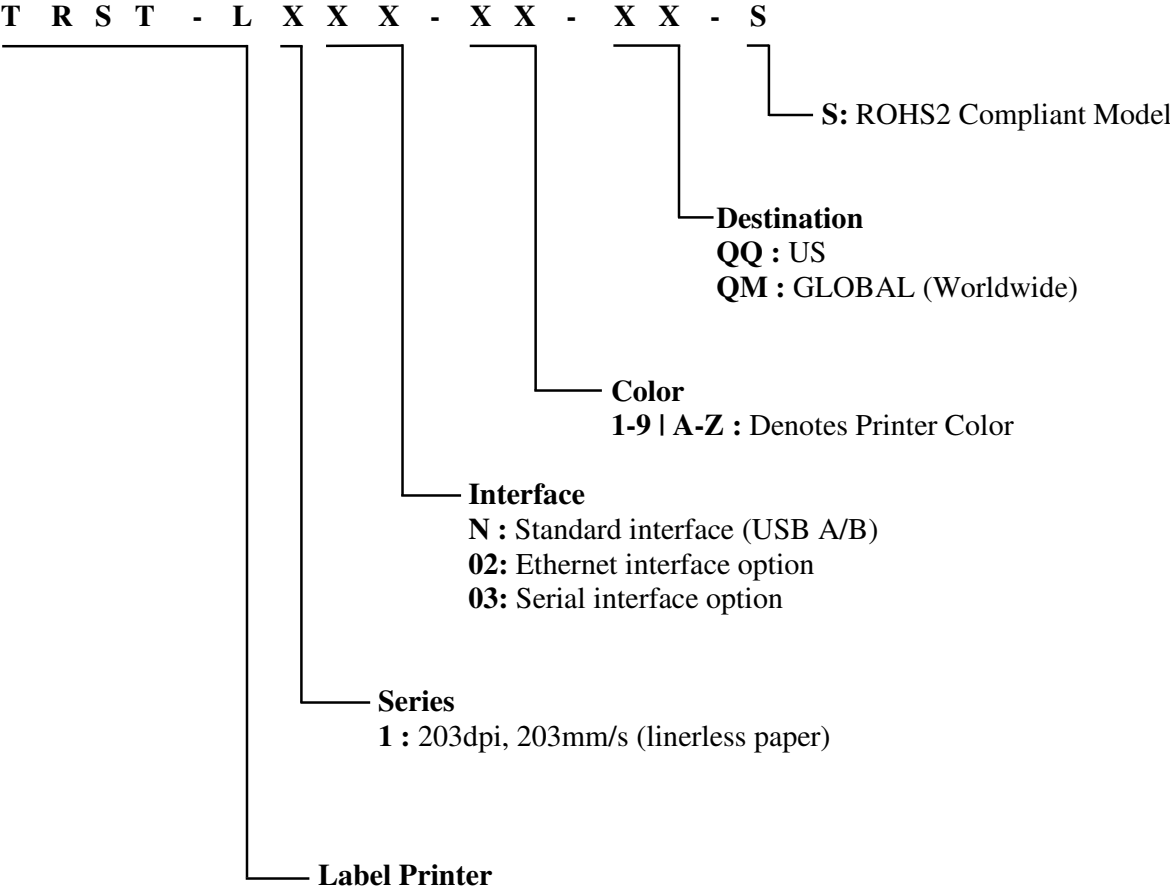

1. PRODUCT OVERVIEW

1.4 Accessories

Confirm that the following accessories are contained in the carton. If any accessories are missing or damaged, contact your TOSHIBA TEC service representative.

The following accessories are packed in the shipping carton box as shown below:

Printer enclosed in a plastic bag and paper pulp pack
Quick Installation Manual (1 copy)

2. SPECIFICATIONS

2. SPECIFICATIONS

2.1 General

Resolution	203.2 dpi x 203.2 dpi (8 dots/mm)		
Interface (USB Type-B)	USB 2.0 High Speed Printer Class		
Interface (USB Type-A)	USB High Speed Mass storage class - File format supported: FAT12,FAT16,FAT32, VFAT - Max. size of USB memory device supported: 32 GB		
Emulation Mode	ESC/POS		
Character set	CP437 (DOS USA), CP850 (DOS Latin 1), CP852 (DOS Latin 2), CP857 (DOS Turkish), CP858 (DOS Latin 1 + Euro), CP860 (DOS Portuguese), CP863 (DOS Fench Canadian), CP865 (DOS Nordic), CP866 (DOS Russian), CP1251 (Windows Cyrillic), CP1252 (Windows Latin 1), CP1253 (Windows Greek), CP1254 (Windows Latin-5 Turkish), CP1256 (Windows Arabic) CP1257 (Windows Baltic)		
Printing Speed	Receipt - Max. 203 mm/Sec (8 IPS) Linerless - Max. 203mm/Sec (8 IPS) Label - Max. 203mm/Sec (8 IPS) Printing speed is varied according to print density.		
Bar code	UPC-A, UPC-E, JAN-13(EAN13), JAN-8(EAN8), CODE39, Interleaved 2 of 5(ITF), CODABAR(NW-7), Code 93, Code 128, PDF417, GS1 DataBar, QR code, Data Matrix, MaxiCode, 2- dimensional GS1 DataBar, Aztec code, Composite Symbology.		
Gray scale printing	16 level gray scale, Print Speed max.4ips		
Character attribute	Double width, Double high, rotate, under line, bold		
Line Spacing	6.0 LPI (default)		
Resident Font (It support two font types)			
Character Cell Size			
- (Font mode1) Font A	12(H) X 24(V) dots		
- (Font mode1) Font B	9(H) X 24(V) dots		
- (Font mode2) Font A	13(H) X 28(V) dots		
- (Font mode2) Font B	10(H) X 28(V) dots		
Column Width	80mm Paper mode	58mm Paper mode	40mm Paper mode
- (Font mode1) Font A	48 columns	34 columns	23 columns
- (Font mode1) Font B	64 columns	44 columns	30 columns
- (Font mode2) Font A	42 columns	30 columns	20 columns
- (Font mode2) Font B	56 columns	40 columns	28 columns
Printable Width ¹	80mm Paper mode	58mm Paper mode	40mm Paper mode
- (Font mode1) Font A	576 dots (72.00 mm)	408 dots (51.00 mm)	276 dots (34.50 mm)
- (Font mode1) Font B	576 dots (72.00 mm)	396 dots (49.50 mm)	270 dots (33.75 mm)
- (Font mode2) Font A	546 dots (68.25 mm)	390 dots (48.75 mm)	260 dots (32.50 mm)
- (Font mode2) Font B	560 dots (70.00 mm)	400 dots (50.00 mm)	280 dots (35.00 mm)
- Graphics	576 dots (72.00 mm)	400 dots (50.00 mm)	280 dots (35.00 mm)

Note:

- Print quality of text, prahics and barcode may defer depending on the type of paper used. Please refer to the *paper mode selection* to select the appropiate paper mode for the paper currently in used or lower the print speed and adjust the print density accordingly
- Linerless label paper adhesive type and pattern may cause print quality such as white streak or disturbance in the line pitch due to the peeling force of the paper.

¹ The printable width for each text is based on cell size.

2. SPECIFICATIONS

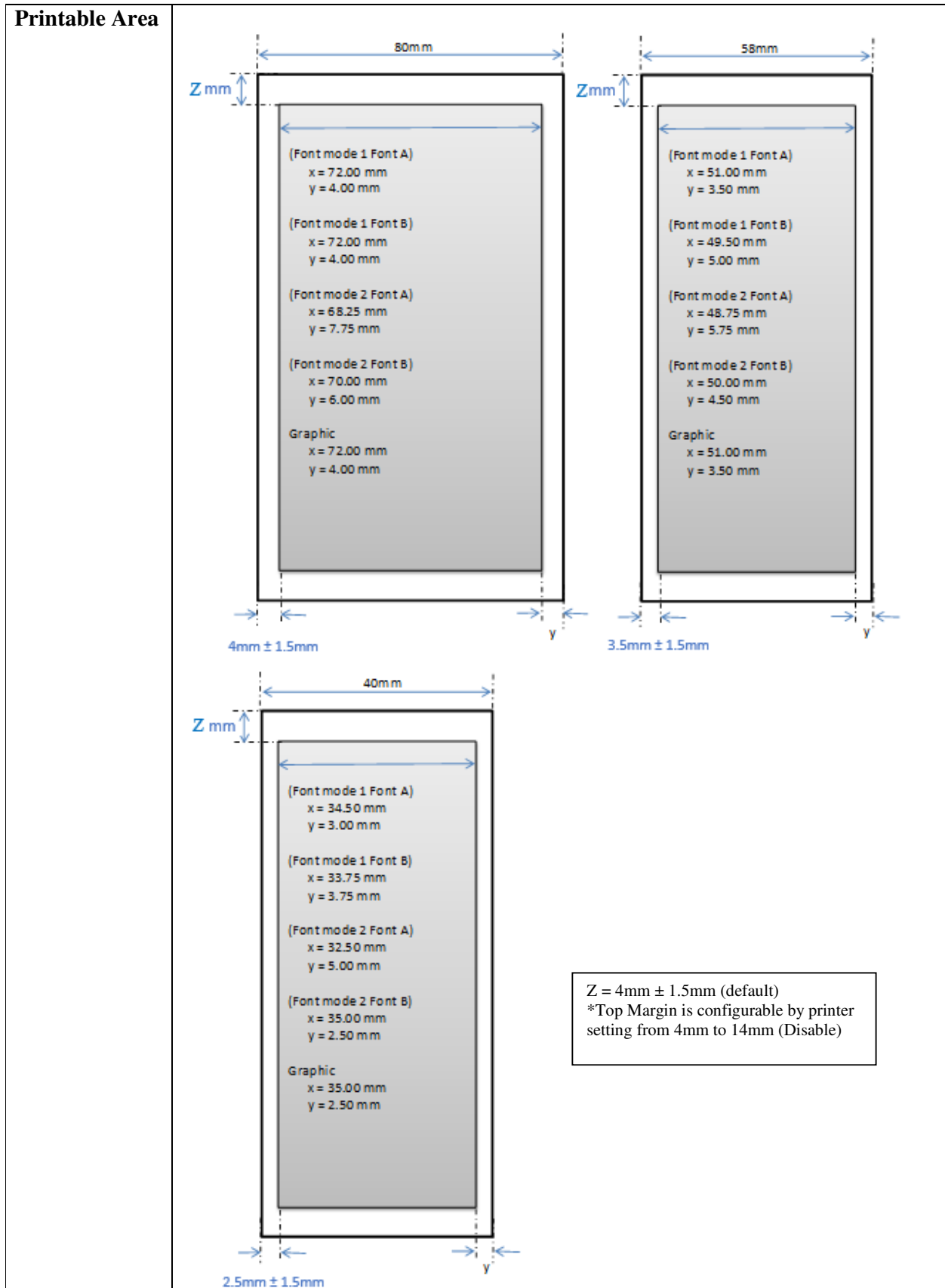

2. SPECIFICATIONS

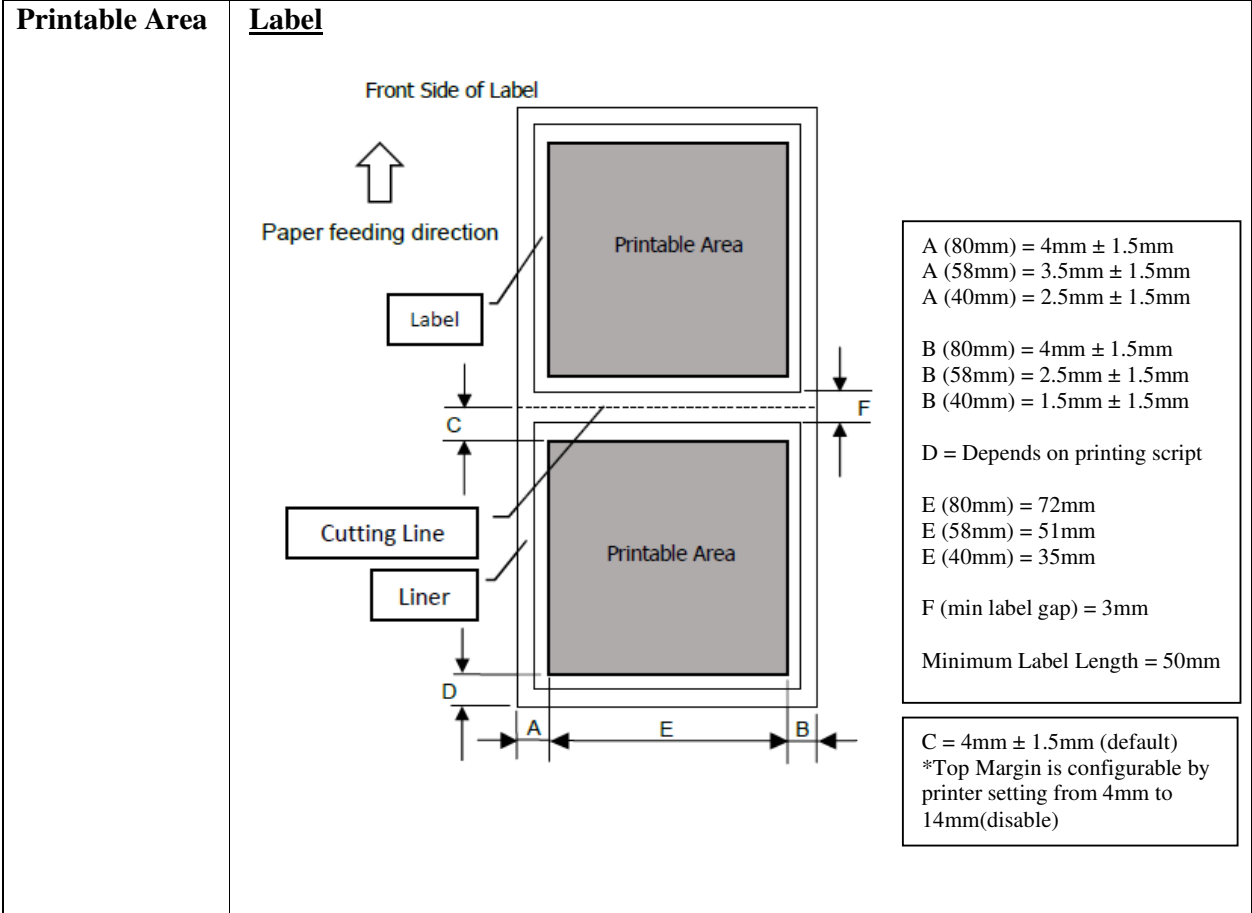

2. SPECIFICATIONS

2.2 Environmental usage conditions

1) During normal operation

Temperature range	: 5 - 50°C (Plain Thermal Paper) 5 - 40°C (Linerless Paper *) * Temperature and Humidity range guaranteed by respective Linerless paper
Temperature change	: Max. 10°C /hour
Humidity range (no condensation)	: 5% - 90%
Temperature at dew point	: Max. 26°C
Humidity change	: Max.10% /hour (at 26°C)

2) In idle mode

Temperature range	: 0 - 55°C
Temperature change	: Max. 10°C /hour
Humidity range (no condensation)	: 5 - 95%
Temperature at dew point	: Max. 26°C

3) Extreme operating range

Temperature range	: 0 - 55°C (Plain Thermal Paper) 0 - 45°C (Linerless Paper *) * Temperature and Humidity range guaranteed by respective Linerless paper
Temperature change	: Max. 10°C /hour
Humidity range (no condensation)	: 10 - 90%
Temperature at dew point	: Max. 45°C

4) Storage

Temperature range (Dry Bulb)	: -10 - 55°C
Max. Temperature Change	: 15°C/hour
Humidity range (no condensation)	: 5% - 90%

5) Transit

Temperature range (Dry Bulb)	: -40 - 60°C
Max. Temperature Change	: 20°C/hour
Humidity range (no condensation)	: 5% - 95%

2. SPECIFICATIONS

2.3 Internal buffers

RAM (Total Size: IRAM 1.25MB, DRAM 8MB)

Interface Receive Data buffer	64 KB
Interface Send Data buffer	1 KB
User-defined Logo buffer	256 KB
Macro buffer	2 KB

Flash Memory (Total Size: 8MB)

User-defined Logo area	256 KB
User-defined Character area	64 KB
User-defined Data area	64 KB
Macro area	2 KB

2.4 Thermal head basic performance

1) Type	: Line thermal
2) Number of heating elements	: 640 dots
3) Dot density	: 8 dots/mm
4) Effective recording width	: 72.00 mm
5) Data transmission method	: 2 serial I/O inputs.
6) Number of strobes	: 2

2.5 Main Card

1) CPU	: STM32H750XBH6
2) Operation Clock (CPU Internal)	: 480 MHz
3) Program ROM	: 128M bits Serial Flash ROM (W25Q6128JV or equivalent)
4) RAM	: 64M bits SDRAM (W9864G6KH-6 or equivalent)
5) I/F circuit	: USB I/F (Type A and Type B)
6) Other I/F Connector	: Cash Drawer Connector
7) Input	: DC 24V Input
8) Indicator and SW	: LED (Blue and Amber) Feed SW
9) Resettable Fuse	: PTC (MINISMDC075F/33-2 or equivalent)

2.6 Option Interface Card

1) Option Interface board 1	: RS232C I/F
2) Option Interface board 2	: Ethernet 10Base-t, 100Base-TX I/F

* Only one optional interface card is available to integrate into the printer.

2. SPECIFICATIONS

2.7 Reliability (TRST-L1)

2.7.1 Life

1.1 Receipt Paper

Thermal print head : 150 km (based on specified paper NPI TF50KS-EY)
Cutter : 2 million cuts (based on specified paper NPI TF50KS-EY)

1.2 Linerless Paper

Thermal print head : 75 km (based on specified paper as listed below)
Cutter : 1 million cuts (based on specified paper as listed below)
Platen : 30 km

Tested Linerless paper list : 1) Iconex: 9023-2240, 9023-0075
2) MAXstick: X2, PLUS D
3) StickyPOS: BT80X270, HTFC10 80X270

Note : Cleaning interval for linerless paper

- a) Thermal print head : 3 km.
- b) Cutter : 40,000 Cuts

2.7.2 Life MTBF (MCBF)

Printer :
Receipt Paper : 48,000,000 Lines* (MCBF)
Linerless Paper : 24,000,000 Lines* (MCBF)
MAIN PCB : 1,700,000 hours (Telcordia RPP, formerly Bellcore)
Interface PCB : RS232 I/F => 43,450,000 hours (Telcordia RPP, formerly Bellcore)
Ethernet I/F => 26,160,000 hours (Telcordia RPP, formerly Bellcore)





Condition:

Above MTBF and MCBF has been confirmed under Normal environment (at 25°C)

*Assume print head as first failure part and line spacing of 8.13LPI

2. SPECIFICATIONS

2.8 Options

Option	Model	Description
Y-cable 	TRST-PC06-QM-S	A 2.5-m (8.2 feet) printer interface cable Printer side: USB Interface connector DC24V Power connector POS terminal side: Powered USB connector
Power Adapter 	TRST-PC04-QM-S	This Power Adapter is for the use of TRST-P1, TRST-P2 and TRST-L1 Series TOSHIBA TEC POS Printer
Serial Interface 	TRST-PC03-QM-S	Serial Interface is used to transmit data from the network to your computer by using RS232 cable.
Ethernet Interface 	TRST-L02-QM-S	Ethernet Interface is used to transmit data from the network to your computer by using Ethernet cable. This Option is exclusive use for TRST-L1 Series Printer.

2. SPECIFICATIONS

2.9 Receipt Roll

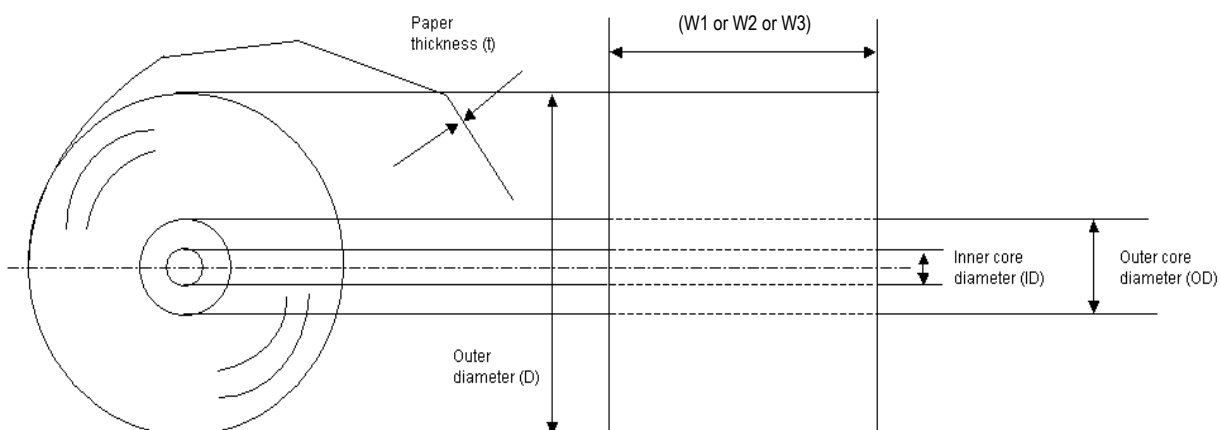

1) Receipt Paper	
Paper type	Thermal paper rolled with the print side facing outside
Width (W1)	80 +0.5/ -1.2 mm
Width (W2)	58 +0.0/ -1.0 mm
Width (W3)	40 +0.0/ -1.0 mm
Smoothness	180 sec. Min.
Outer diameter (D)	101.6 mm or less
Paper thickness (T)	0.056 ~0.070 mm
Weight	58~75 g/m ²
Outer core diameter	15 mm
Recommended thermal paper	Only paper rolled onto a core is acceptable, however, the paper end should not be pasted to the core. TOSHIBA TEC recommends using the following thermal paper for this product. Manufacturer : NIPPON PAPER Type : TF50KS-EY
2) Linerless Paper	
Paper type	Linerless paper rolled with the print side facing outside
Width (W1)	80 +0.5/ -1.2 mm
Width (W2)	58 +0.0/ -1.0 mm
Width (W3)	40 +0.0/ -1.0 mm
Smoothness	180 sec. Min.
Outer diameter (D)	101.6 mm or less
Paper thickness (T)	0.06 ~ 0.10 mm
Weight	50~70 g/m ²
Outer core diameter	25.4 mm min
Recommended thermal paper	1) Iconex : 9023-2240, 9023-0075 2) MAXstick : X2, PLUS D 3) StickyPOS: BT80X270, HTFC10 80X270

2. SPECIFICATIONS

3) Liner Label	
Paper type	Continuous Label backing should be grassine paper (7K or 8K, white) or equivalent. (at least 22% transmittance)
Width (W1)	80 +0.5/ -1.2 mm
Width (W2)	58 +0.0/ -1.0 mm
Width (W3)	40 +0.0/ -1.0 mm
Smoothness	180 sec. Min.
Outer diameter (D)	101.6 mm or less
Paper thickness (T)	0.06 ~ 0.16 mm
Weight	50~70 g/m ²
Outer core diameter	25.4 mm min
Recommended thermal paper	LINTEC DT PW-7 6K

⚠ CAUTION!

Use only paper which meets specified requirements. Use of non-specified paper may shorten the head life of the printer, resulting in problems with print quality, and cause a paper feed failure or shorten the cutter life. All paper should be handled with care to avoid any damage to the paper. Read the following guideline carefully.

- Do not store the paper for longer than the manufacturer's recommended shelf life.
- Store the paper in a cool, dry place. Avoid areas where they would be exposed to direct sunlight, high temperature, high humidity, dust or gas.
- A contact of chemical or oil may discolor or erase the printed record.
- Rubbing the paper hard with nail or hard object may discolor the paper.
- The paper end should not be pasted to the core.

For further information please contact your authorized TOSHIBA TEC representative or authorized paper manufacturer.

3. APPEARANCE

3. APPEARANCE

3.1 Front/Rear View

Front View

Rear View

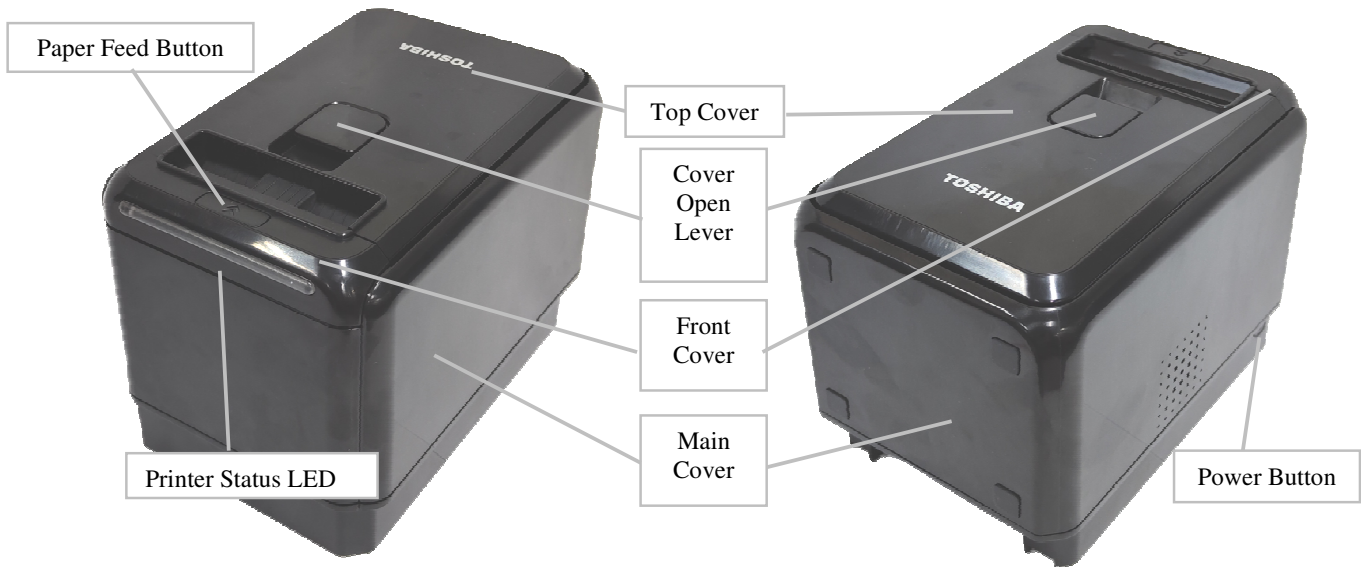

- Top Cover — Open this cover to load paper
- Cover Open Lever — Lift this lever to open top cover
- Paper Feed Button — Press this button to feed paper or to change printer settings
- Printer Status LED — Indicates status and error of printer (Two color: Blue and Amber)
- Power Button — Press this button to turn on or off the printer

3.2 LED and Feed Button



PAPER FEED BUTTON

Used to feed receipt paper. A press on this button causes one line feed. Pressing and holding it feeds the paper continuously. While the printer cover is open, press and hold the feed button until the printer first beeps. Close the cover and the printer enters offline diagnostic mode.

POWER (Blue) & ERROR LED (Amber)

Lights when the power supply is turn on.
The Error LED indicates an error by showing different blinking patterns. Please refer to **Section 8.4 “LED Indication Table”** for more information.

3. APPEARANCE

3.3 Connectors

⚠ CAUTION!

1. The drawer interface connector is exclusively for connecting the drawer. Do not connect a phone line or any other cables than the drawer cable to this connector. Doing so may cause a failure of the phone line and this printer.
2. To the DC24V connector (Power connector), do not connect anything other than the TOSHIBA TEC recommended power adapter.
3. The TOSHIBA TEC recommended power adapter be exclusively for this printer. Do not use it for any other machines.

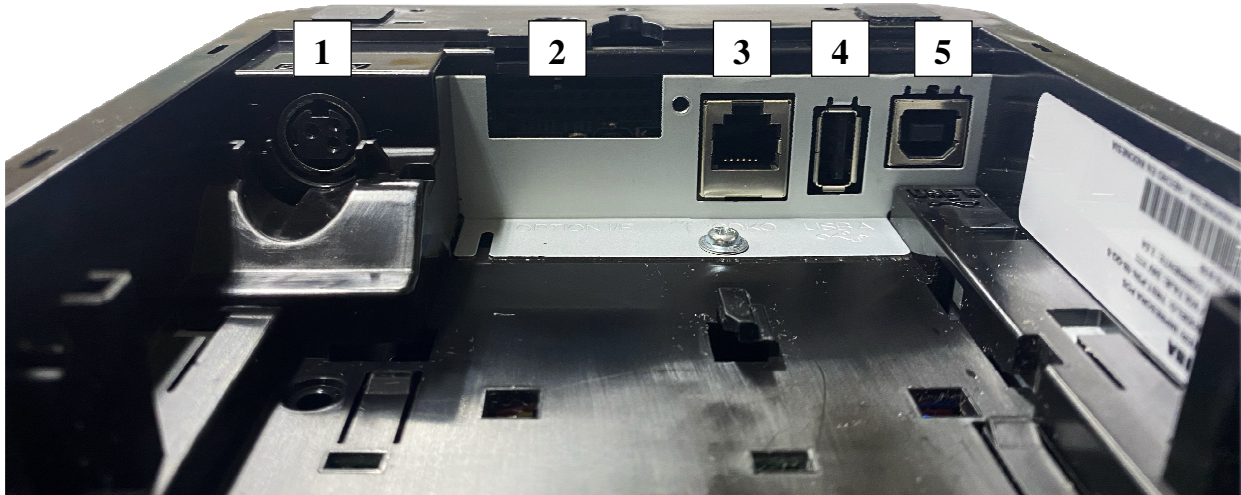

1. [DC24V] (Power connector)

The external power adapter supplies +24V power to the printer through this connector. Further information can refer to **Section 2.8 “Option Table”** and **Section 3.4.4 “Power Cable Connector”**.

2. [Serial or Ethernet interface connector] (Option)

A connector, which needs an interface cable connecting the printer to a POS terminal. A RS232 interface cable (Serial I/F model) or an Ethernet interface cable “Ethernet I/F model” is need for this connector. Further information can refer to **Section 3.4.1 “RS232 Interface”** and **3.4.2 “Ethernet Interface”**.

3. [Drawer interface connector] [CDKO] (6 pin modular connector)

A drawer cable, which connects the printer to a drawer, is connect to this connector. Do not connect anything other than the connectable drawer. Further information can refer to **Section 3.4.5 “Cash Drawer Connector and Pin Assignments”**.

4. [USB Type-A interface connector]

An external thumb drive can be connect to this connector for printer configuration and Firmware flashing purpose. Further information can refer to **Section 3.4.3 “USB Interface”**.

5. [USB Type-B interface connector]

A connector, which needs an interface cable connecting the printer to a POS terminal. An USB I/F (V2.0 Full Speed) is need for this connector. Further information can refer to **Section 3.4.3 “USB Interface”**

3. APPEARANCE

3.4 Specification of Interface & Power Connector

3.4.1 RS232C Interface

RS232C Option I/F is transmitted through the full duplex serial port. The specification is as follows.

- 1) Baud Rate : 115200, 57600, 38400, 19200, 9600 bps
- 2) Data transfer protocol : DTR/DSR or XON/XOFF
- 3) Parity Bits : Non-parity, Even parity or odd parity
- 4) Data Length : 7 bits or 8 bits
- 5) Stop Bits : 1 bit or 2 bits
- 6) Connector Pin Assignment

Serial I/F connector is 9pin D-SUB Male type connector with the following pin assignments:

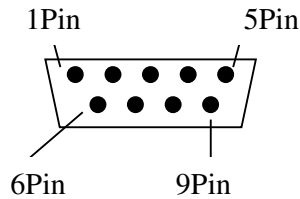

Pin Number	Pin Function
1	Not Used
2	RXD
3	TXD
4	DTR
5	Logic GND
6	DSR
7	RTS
8	CTS
9	Not Used

3.4.2 Ethernet Interface

The specification of Ethernet Option I/F is as follows.

- 1) Standard : Fully Compliant with IEEE 802.3u Standard (10BASE-T/100BASE-TX)
- 2) Speed: Auto Negotiation : 10Mbps/100Mbps, Full/Half Duplex
- 3) Connector Pin Assignment :

The Ethernet I/F connector is an 8P8C modular connector (Usually called RJ45) with the following, pin assignments:

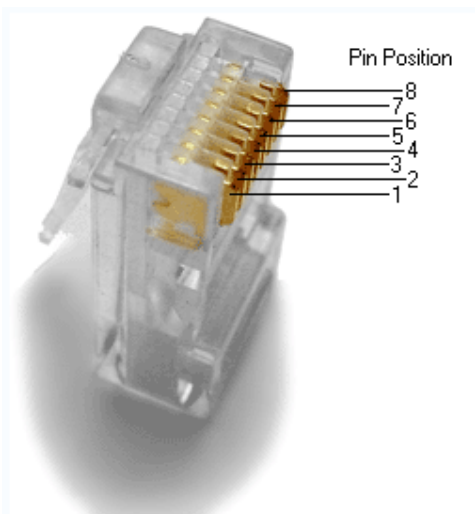

- Pin Position 1 – TX+
- Pin Position 2 – TX-
- Pin Position 3 – RX+
- Pin Position 6 – RX-

3. APPEARANCE

3.4.3 USB Interface

USB I/F is mounted on main card as default. There are 2 ports. 1st port is for Host function with Type A connector and 2nd is for Device function with Type B connector. It does not support USB host port and device port at the same time.

1) USB Version : Version 2.0 High speed

2) Connector Pin Assignment

The USB I/F connector is “B” Plug type for Device function. And “A” Plug type for Host function.

Type B connector

1	VBUS
2	D-
3	D+
4	GND
Shell	Shield

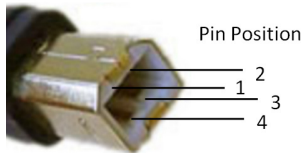

Type A connector

1	VBUS
2	D-
3	D+
4	GND
Shell	Shield

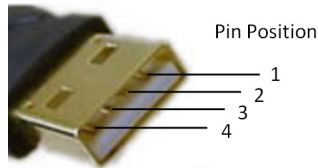

Note: For USB type A, refer to Appendix B for thumb drive size supported by printer.

3.4.4 Power Cable Connector

The control cards received 24VDC \pm 10% power via a 3-pin Mini-DIN plug, which mates with an integral shielded cable from the power supply unit.

The power connector is WIESON GA1009-3AT1N1 (or equivalent) with the following pin out:

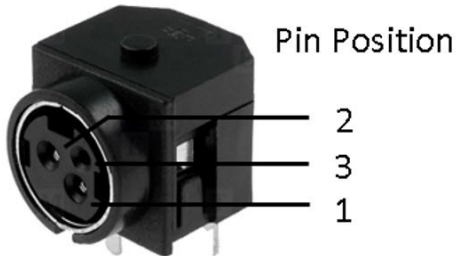

1	+24VDC
2	Power Ground
3	NC
Shell	Frame Ground

3. APPEARANCE

3.4.5 Cash Drawer Connector and Pin Assignments

The Cash drawer connector is located at the rear of the printer.

The Cash drawer connector is a 6-pin modular type connector with the following pin assignments:

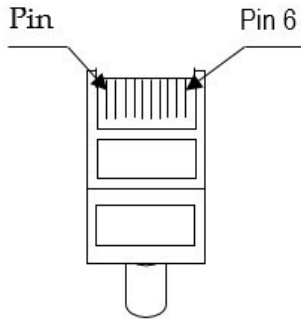

Pin Number	Pin Function
1	Frame GND
2	Drawer 1 Solenoid
3	Drawer 1 Status Switch
4	+24 Volts (to Solenoid)
5	Drawer 2 Solenoid
6	GND

4. SET UP PROCEDURE

4. SET UP PROCEDURE

4.1 Requirements for Operation

This printer needs the following requirements for communication and power:

Serial Interface Type

The POS terminal to be connected must have a Serial port.

To communicate with the POS terminal, an RS232C interface cable is required. Further information can refer to **Section 3.4.1 “RS232C Interface”**.

Ethernet Interface Type

The POS terminal to be connected must have an Ethernet port.

To communicate with the POS terminal, an Ethernet interface cable is required. Further information can refer to **Section 3.4.2 “Ethernet Interface”**.

USB Interface Type

The POS terminal to be connected must have an USB port.

To communicate with the POS terminal, a USB cable is required. Further information can refer to **Section 3.4.3 “USB Interface”**.

Power Supply

To supply power to printer with Power adapter (Option), or use Y cable (Option) to supply power from POS terminal to printer through power connector or USB connector, refer to **Section 3.4.4 “Power Cable Connector”**.

*To prevent the emission and receipt of electrical noise, the interface cable must meet the following requirements:

Fully shielded and fitted with metal or metalized connector housings.

Kept as short as possible.

Should not be tightly bundled with the power cord.

Should not be tied to power line conduits.

Power Mode

The printer supports 2 power modes as below:

- Low Power Mode (Configuration print displays “55W”)
Maximum allowable printing cycle power consumption is 60W.
- High Power Mode (Configuration print displays “60W”)
This mode is supported with certified Power Supply (FSP060-RAAK3)
Maximum peak current during printing is 13A/500us (50% duty)

The mode should be adjusted accordingly based on the source of power. Refer to **Section 6.3 “Sub Menu”** for more information.

Power Saving

The printer is certified to the Energy Star Requirements as defined by the “*ENERGY STAR® Product Specification for Imaging Equipment, Version 3.0*”. Refer to **Section 4.3 “Turning off the printer”** for more information.

4. SET UP PROCEDURE

4.2 Setting up the Printer

⚠ CAUTION!

1. Place the printer on a flat, stable surface.
2. Do not place the printer close to a heater or where it may be exposed to direct sunlight.
3. Avoid locations where the printer may be exposed to high temperature, high humidity or dust.
4. Care must be taken that no condensation occurs in the printer. If it should, however, do not turn ON the power supply until the condensation is dried.
5. Use a grounded electrical outlet. Do not use an adapter plug.
6. Be sure that there is adequate room around the printer for easy operation and maintenance.
7. Keep your work environment static free.

- 1) Make sure that the printer does not connect to power supply.
- 2) Connect the adapter cable to the printer.
- 3) Insert the power cord into the AC inlet.
- 4) Connect the interface cable to a POS terminal, and plug in the power cord to the AC outlet.
- 5) If a drawer is desired to be connected, connect the drawer interface cable to the printer.
- 6) Secure the drawer ground wire to the ground terminal on the rear of the printer.
- 7) Turn the printer power ON by switching on the power supply.
- 8) Open the printer cover.
- 9) Load the receipt roll into the printer.
- 10) Close the printer cover.
- 11) Check the print quality by performing an Offline Diagnostic.
- 12) Install the printer driver given into POS terminal.
- 13) Connect the correct interface cable to the printer and the POS terminal.

Now the printer is ready for printing.

NOTES:

1. *For details of the above steps 1) to 4), refer to Section 5.1 “Connecting the Power Cord and Interface Cables”.*
2. *Steps 5) and 6) are the procedures of the drawer connection. For details of Steps 5) and 6), refer to Section 5.1.6 “Connecting via Cash Drawer”.*
3. *For details of Steps 8) to 10), refer to Section 5.3 “Loading the Receipt Roll”.*
4. *For details of Step 11), refer to Section 6.0 “Diagnostic”.*
5. *For details of step 12), refer to Section 5.4 “Driver Installation”.*

4.3 Turning off the Printer

- 1) Open the printer cover by pulling the lever up.
- 2) Press and hold the feed button for 5 seconds until double ‘beep’ sound. During pressing, the printer will produce first ‘beep’ sound and followed by double ‘beep’ sound.
- 3) LED light will turn off indicates the printer is turned off.
- 4) Close back the top cover.
- 5) To turn on the printer back, press the feed button again and the LED will light up.

5. INSTALLATION PROCEDURE

5. INSTALLATION PROCEDURE

⚠WARNING!

Since the power cord and the interface cable are not provided with this unit, please locally purchase ones that meet the specifications. For detail specifications, please contact the nearest authorized TOSHIBA TEC representative.

Before connecting the power cord and cables to the printer, please turn off the power supply of the POS terminal and the printer.

Do not pull the power cord hard. Doing this may damage the power cord, causing fire, electric shock, or broken wire.

When it thunders, unplug the power cord. Lightning stroke may cause fire or electric shock.

Keep the power cord away from a heater. The cover of the power cord may be melted, causing fire or electric shock.

Do not connect the power cord to the AC outlet provided on the POS terminal.

⚠CAUTION!

When separating the power adapter, please contact your authorized TOSHIBA TEC representative.

The recommended power adapter is exclusively for this printer. Do not use it for any other machines.

The power adapter can be used indoors only. Never use it outdoors.

Be sure to unplug the printer when it is not used for a long time.

Do not share the power source with other electric appliances which generate noise.

5. INSTALLATION PROCEDURE

5.1 Connecting the Power Cord and Interface Cable

⚠CAUTION!

Be sure to hold the connector when plugging in or unplugging the power adapter cable.
Insert the power adapter cable and the power cord firmly.

5.1.1 Connect to Power Adapter

Insert the power cable into the power connector.



5.1.2 Connect via standard USB Type-B Cable

Connect USB Type-B is to link the printer to the POS Terminal.



5. INSTALLATION PROCEDURE

5.1.3 Connect via Option Card (RS232C & LAN)

Remove the screw to detach the option metal cover in order to install the option cards. Remove the other screw also as this will be used to secure the option assembly.

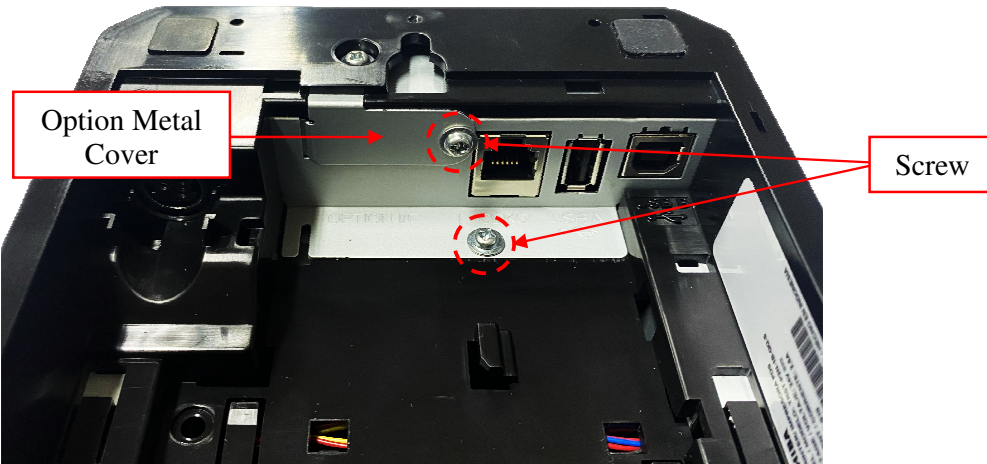

Serial Interface (RS232C) Option:

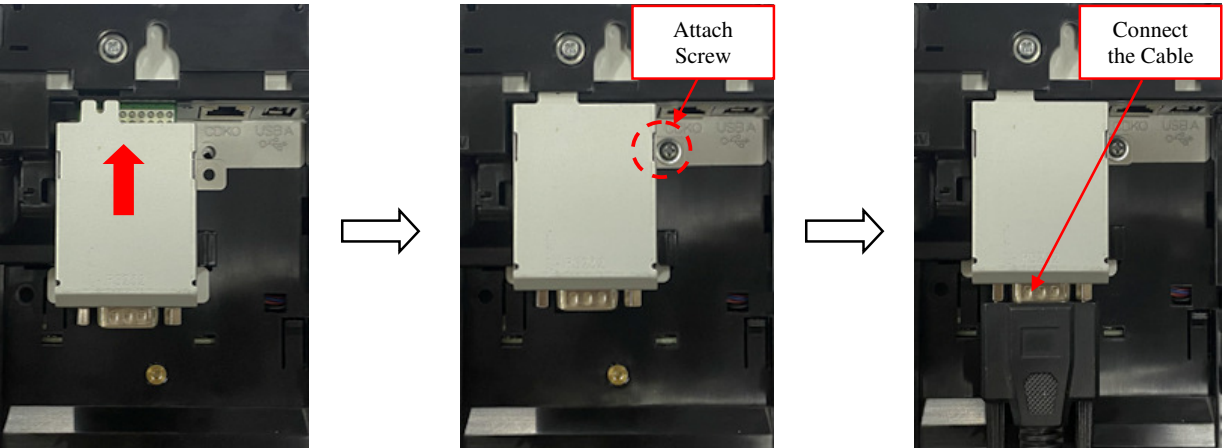

Ethernet Interface (LAN) Option

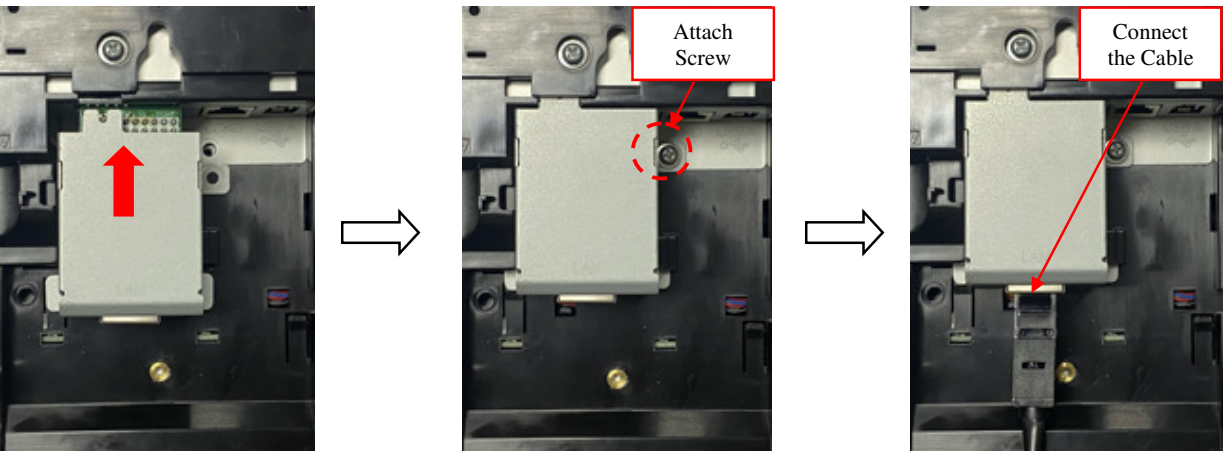

5. INSTALLATION PROCEDURE

5.1.4 Connect via Y-Cable

Y-cable is an option to connect power connector and USB Type-B connector to POS terminal.

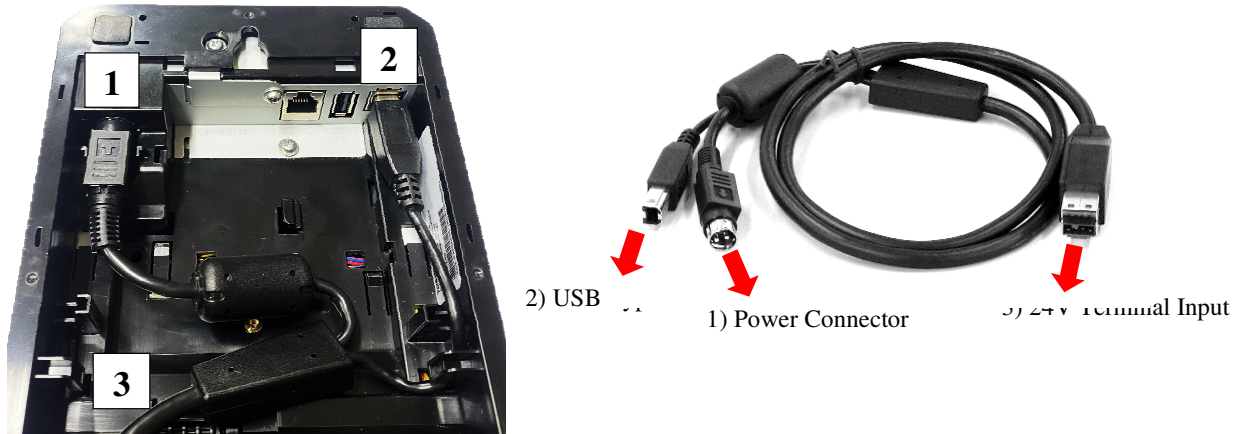

5.1.5 Connecting via Cash Drawer

- 1) Make sure that the printer does not connect to any power supply.
- 2) Connect the drawer cable to the drawer interface connector in the correct orientation.

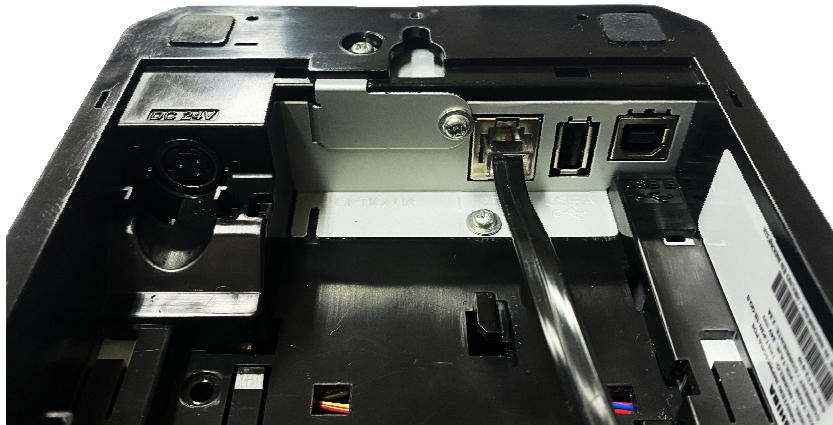

[Drawer interface connector] (6-pin modular connector)

A Drawer cable which connects the printer to a drawer is connected to this connector. To this connector, a TOSHIBA TEC drawer can be connected. Further information please refer to **Section 3.4.5 “Cash Drawer Connector and Pin Assignments”**.

5. INSTALLATION PROCEDURE

5.1.6 Interface cable to POS terminal connection position

Connect the interface cable to the POS terminal, and then plug in the power cord to the AC outlet.

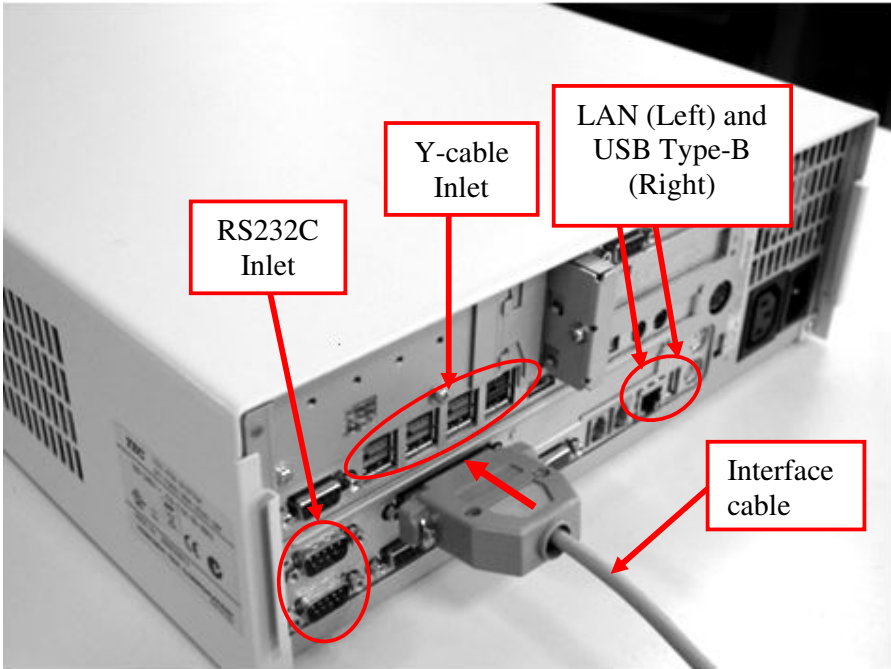

5. INSTALLATION PROCEDURE

5.2 Choosing a Location

Table Top – Horizontal orientation

The POS printer takes up relatively little counter space and may be set on or near the POS terminal. Make sure that there is enough room to open the receipt cover for changing the paper roll. The paper will be presented in the top exit direction.



Table Top/Under Counter – Vertical orientation

The POS printer can also be mounted in vertical manner as shown below. The paper will be presented in the front exit direction. Hence it is also suitable to be placed under the counter.



5. INSTALLATION PROCEDURE

3. Wall Mounted – Vertical orientation

⚠ CAUTION!

The wall mounting printer must be installed by a **qualified and professional installer** who is familiar with building construction methods, building materials, building codes, electrical codes, fire codes, and local laws governing public access areas.

There is a wide variety of types of wall construction, age and condition. After reviewing the conditions onsite, the installer must make the final judgment as to the suitability of the existing wall material to determine if additional bracing or supports are required. Attaching the screws involve making minor modifications to the building construction. Be sure to observe proper safety precautions to prevent injury. Unforeseen hazards, for example, natural gas and power lines, can exist when drilling and cutting into walls.

Screws are not included with the printer and must be supplied by the installer. The type of screws required are flat head metallic screws. Screw sizes can be referred at the figure below.

Mount the printer to a flat, sturdy, structurally sound column or wall surface. Before installing the wall mounting printer, ensure that all applicable building and electrical codes and accessibility requirements and guidelines are followed. Compliance with local building codes, electrical codes, and governing laws should take precedence over this set of instructions.

The POS printer may be mounted on vertical wall. Make sure there is enough room to open the receipt cover to change the paper. Mount the screws on the wall using the following recommended mount dimensions. To fix the printer securely, install the screws on the wall made of **wood, concrete, or metal**. The thickness of the wall should be **10 mm (0.4")** or more. Be sure to use **flat head metallic tapping screws**. Make sure that the POS printer fix on the mounting heights of **2 meters and below**.

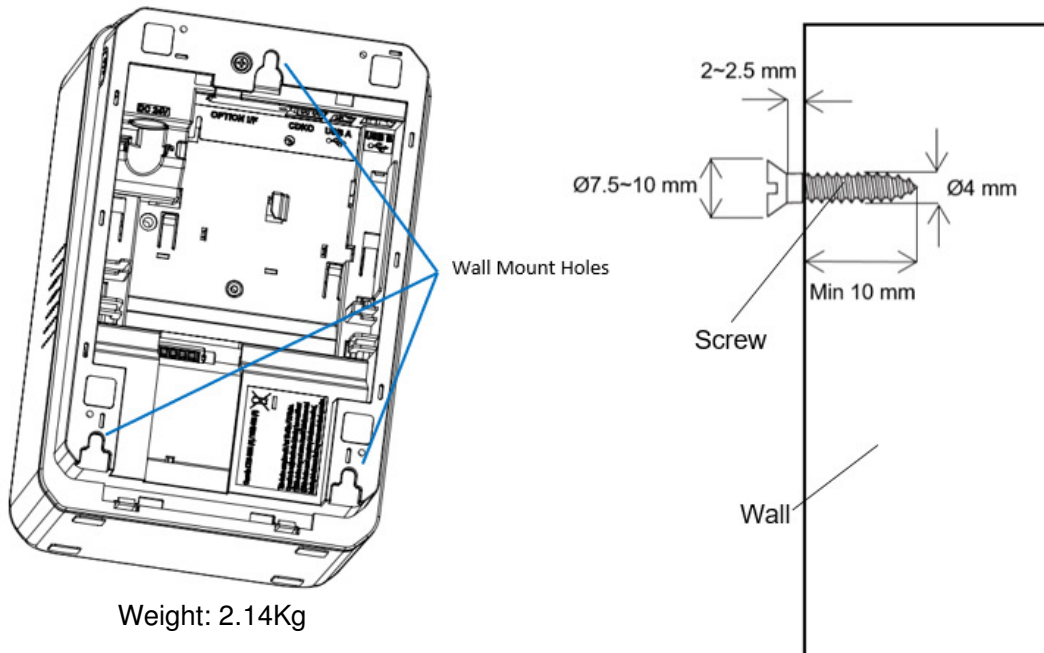

Weight: 2.14Kg

*Below guide can be printed out in A4 size as a reference for the wall mount. Since printing A4 paper settings may vary across different printers, please measure and ensure the distances are the same as the dimensions stated before drilling the wall.

5. INSTALLATION PROCEDURE

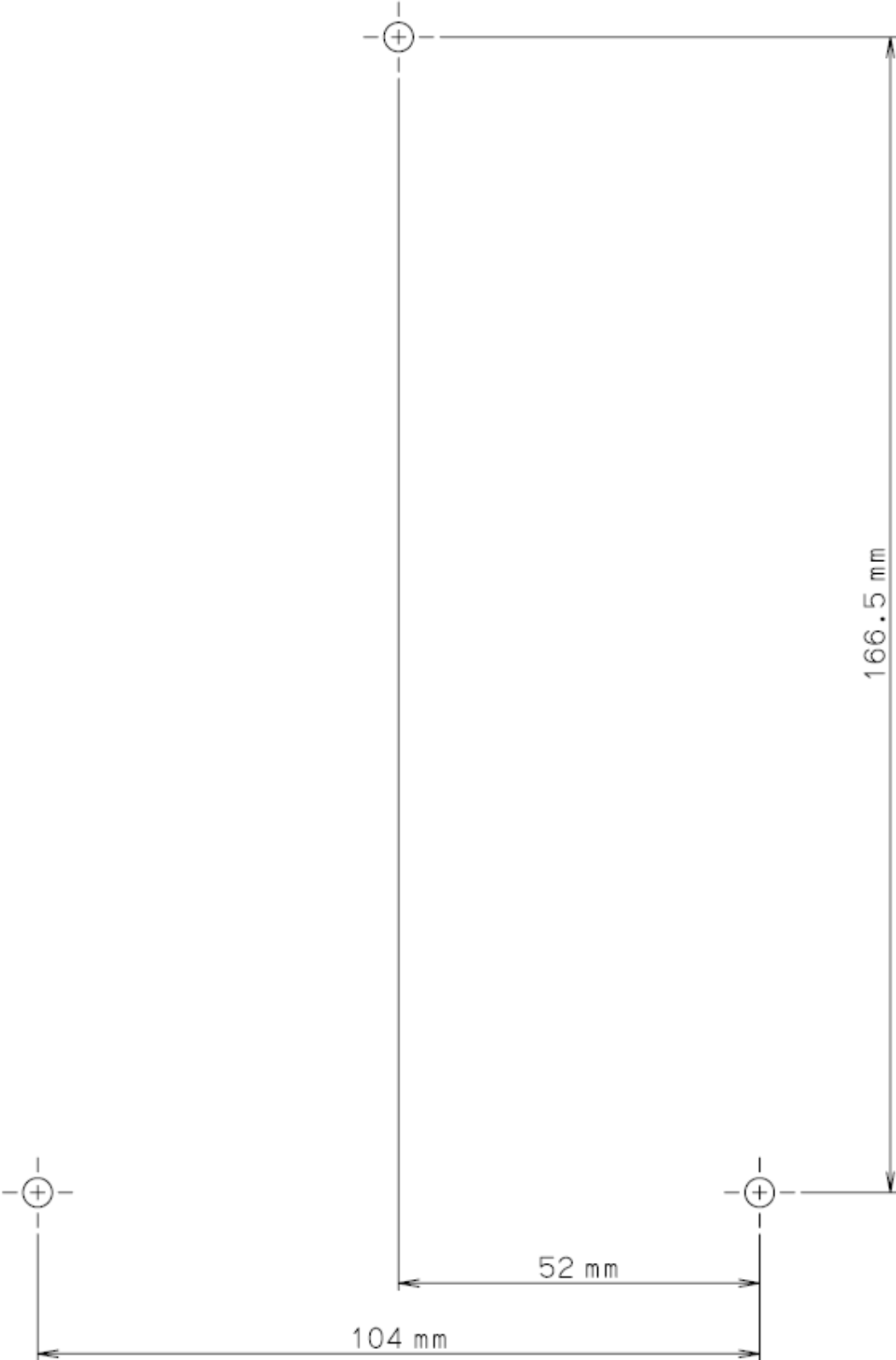





5. INSTALLATION PROCEDURE

5.3 Loading the Paper Roll

When you use the printer for the first time or when the receipt paper has been used up, load a paper roll following the procedures while the printer power is still connecting to power supply and is set to ON.

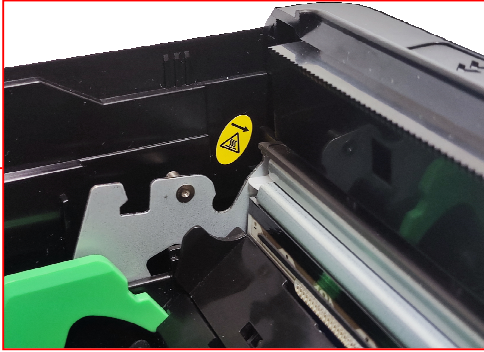
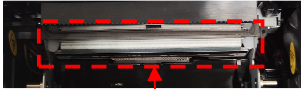
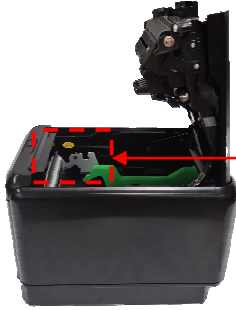
A POS printer prints thermal receipt paper by applying heat to the paper to react with the chemicals on the paper surface. Paper Low sensor and the LED blinking pattern will indicate that the paper roll conditions.

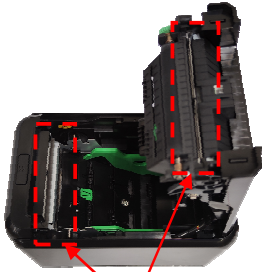
WARNING! 			
		 Print Head	The print head becomes very hot while printing. Never touch the print head to avoid getting burned. Standard operating temperature of printer is 5°C to 50°C. Please do not operate out of range for safe operation.
		 Cutter Blades	Hazardous moving cutter. Keep fingers and other body parts away.

5. INSTALLATION PROCEDURE

⚠ CAUTION!

1. Use only TOSHIBA TEC specified paper. Use of non-specified paper may shorten the print head life resulting in problems with print quality, paper feed failure, or shorten the cutter life.
2. Do not subject the thermal receipt roll to water, oil, or heat source as this will darken the paper.
3. Load the receipt roll in the correct orientation. Failure to do this may cause a paper jam error.
4. Care must be taken not to damage the print head and platen when the printer cover is opened as this may cause a poor print or a printer failure.
5. Do not open the printer cover while the printer is printing.
6. Do not hold the receipt while the printer is printing. Doing so may cause a paper jam.
7. When closing the printer cover, do not press it down too hard.
8. Do not put anything on the printer cover or push the cover too strongly. Doing so may cause a print failure.

Turn the printer power ON by connecting to power supply.
Pull up the cover open lever to open printer top cover.

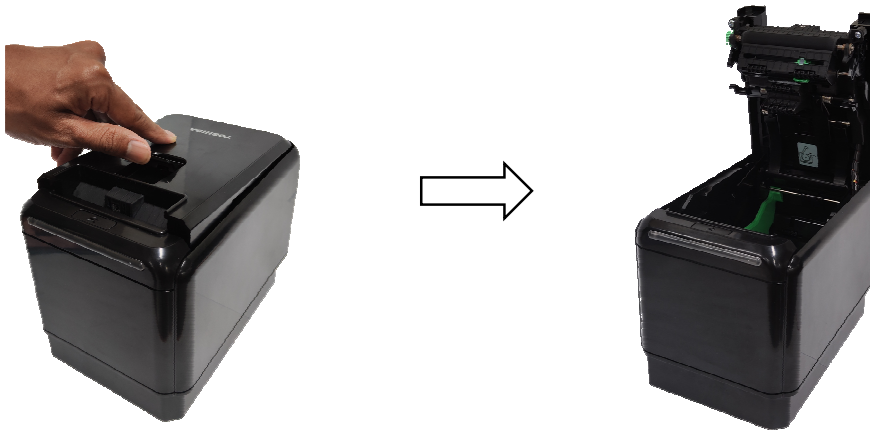

Check for the correct orientation of the receipt roll, and load into the paper holder.
Pull the receipt until it extends past the paper outlet for about 5 cm.



Horizontal Orientation



Vertical Orientation

6. DIAGNOSTICS

Close the printer top cover gently and printer will automatically perform auto cut.



Horizontal Orientation



Vertical Orientation

5.4 Changing Paper Guiding Width

Printer auto detect paper width setting based on paper guide position. To manual change 58 mm or 40 mm print width, refer to 6.3 Sub Menu, select “Paper Width” and select 58 mm or 40 mm.

To shift the paper guide, pull paper guide to unlatch from printer and shift the paper guide to the slots 58 mm or 40 mm located inside of the printer.

Place the 58 mm or 40 mm paper roll inside and close the cover.



80mm Width setting



58mm Width setting

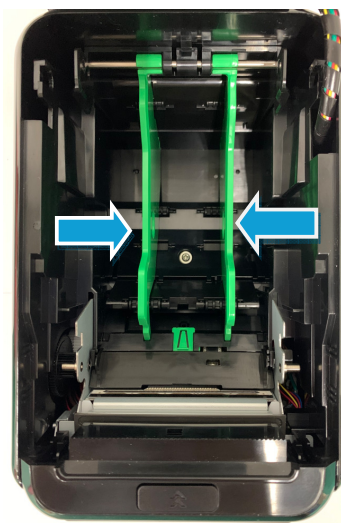

40mm Width setting

CAUTION!

Platen worn out depend on different paper width and print head contact, after start using printer with shorter width paper, please do not change to wider width paper, as it might affect print quality due to uneven platen worn out.

6. DIAGNOSTICS

5.5 Black Mark Sensor Configuration

Black Mark detection location is adjustable, you can shift Black Mark sensor holder to position where black mark located.

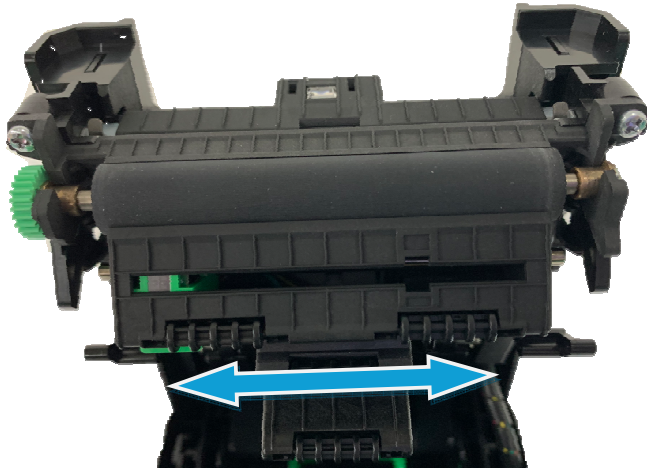

Adjustable Black Mark Sensor

For Label “Gap” mode selection, sensor to shift to indicated position below for label gap detection.

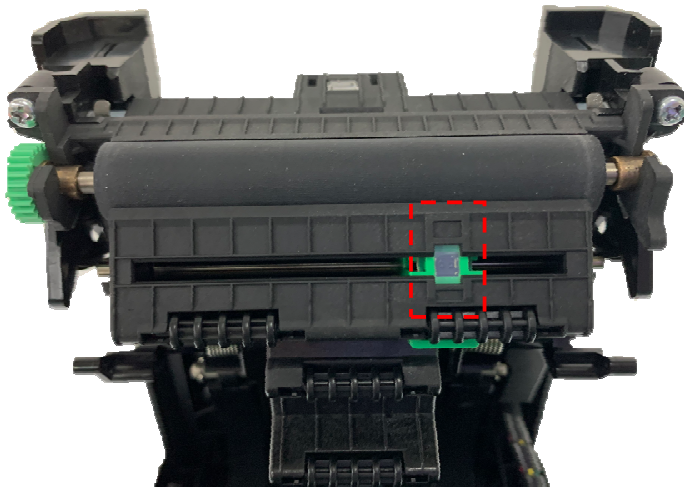

Label Gap detection location

6. DIAGNOSTICS

5.6 Paper Damper Configuration

When print is in label mode, push paper damping mechanism in flat condition, and push green color feature downward to lock the damping mechanism.

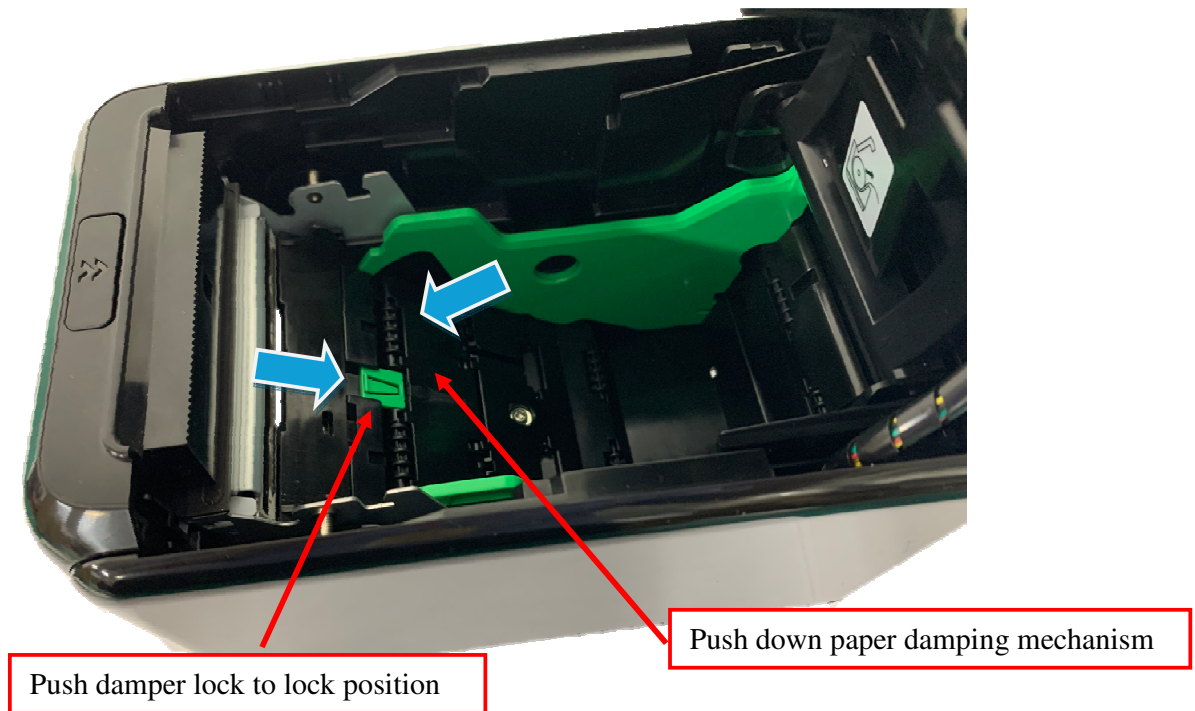

5.7 Minimum Paper Print Length

There is a minimum paper feed length requirement for a printer, when paper print length is not enough, it may cause paper jam or difficult to remove paper from printer.

Below the matrix is recommended minimum print length for all cases.

Cutter Setting	Printer Orientation	Minimum Print Length
Partial Cut	Horizontal	25 mm
Partial Cut	Vertical	25 mm
Full Cut	Horizontal	37 mm
Full Cut	Vertical	25mm

6. DIAGNOSTICS

6. DIAGNOSTICS

6.1 Offline Diagnostic

While the printer cover is open, press and hold the feed button until the printer beeps once. Close the cover and the printer prints the configuration form. Press feed button by a short press to enter offline diagnostic mode or press it long to exit to online mode.

In 203dpi model, it always prints in Font 1 in Offline Diagnostic regardless of the font setting.

6.2 Main Menu

Once it enters offline diagnostic mode, it prints main menu as follows.

```
Model number       : xxxx-xxxx-xxxx
Serial number      : 1234567890
Boot Firmware     : V00.11 / C79F
Main Firmware     : V00.30 / 765D
Table Firmware    : V00.20 / 10A9
Font (SBCS)       : V10.00

Offline Diagnostic (Main Menu) ***
To select an option, press the key by a short press
followed by a long press.

To Exit Offline Diagnostic  -> No click
To Paper setting           -> 1 click
To Printer Maintenance     -> 2 clicks
To Print Config Form       -> 3 clicks
To Change Setting          -> 4 clicks
To Clear User Define Data. -> 5 clicks
To Reset to Default Setting -> 6 clicks
To Change RS232C Settings  -> 7 clicks
or
To Change Ethernet Settings -> 7 clicks
```

Pressing the key by a short press followed by a long press according to the guidance on the menu executes following diagnostic.

To Exit Offline Diagnostic

It exits Offline Diagnostic mode and it goes to online mode after the reset.

To Paper setting

It goes to Sub Menu that guides an operator to change paper related settings.

To Printer Maintenance

It goes to Sub Menu that guides an operator to get and change maintenance related information and settings.

To Print config Form

It prints the printer configuration form. After that, it will go back to Main Menu printout.

To Change Setting

It goes to Sub Mene that guides an operator to change printer settings.

To Clear User Define Data

It clears all user define data. After that, it will go back to Main Menu printout.

6. DIAGNOSTICS

To Reset to Default Setting

It changes all the settings to the default value and it goes to Final Confirmation Menu.

To Change RS232 Settings or Ethernet Settings

It goes to Sub Menu that guides an operator to change option interface setting.

6.3 Sub Menu

Once a menu to change a setting is selected in main menu, it prints sub menu as follows.

This menu is to select an item to change a setting by pressing the feed button by a short press followed by a long press for 3 seconds and release according to the menu guideline.

1) Paper Settings

***** Printer Settings *****	
To select an option, press the key by a short press followed by a long press.	
Main Menu	-> No click
Media Type	-> 1 click
Paper Type	-> 2 clicks
Paper Mode	-> 3 clicks
Paper Width	-> 4 clicks
Paper Low Detection	-> 5 clicks

2) Printer Maintenance

***** Printer Maintenance *****	
To select an option, press the key by a short press followed by a long press.	
Main Menu	-> No click
To Printer Maintenance QR	-> 1 click
To Cleaning Setting	-> 2 clicks
To Reset Tallies After Part Replacement	-> 3 clicks

3) Change Setting

***** Printer Setting *****	
To select an option, press the key by a short press followed by a long press.	
Main Menu	-> No click
Next Page	-> 1 click
Code Page	-> 2 clicks
Font size	-> 3 clicks
Default LPI	-> 4 clicks
⋮	⋮
Power Off Mode	-> 10 clicks

6. DIAGNOSTICS

4) RS232C Settings

***** **RS232C Settings** *****

To select an option, press the key by a short press followed by a long press.

Main Menu	-> No click
Baud Rate	-> 1 click
Data Bits	-> 2 clicks
Stop Bits	-> 3 clicks
Parity	-> 4 clicks
Flow Control	-> 5 clicks
Reception Errors	-> 6 clicks
DSR Signal	-> 7 clicks

5) Ethernet Settings

***** **Ethernet Settings** *****

To select an option, press the key by a short press followed by a long press.

Main Menu	-> No click
DHCP	-> 1 click
Physical LAN Speed	-> 2 clicks
Link down Timeout	-> 3 clicks
TCP Idle Timeout	-> 4 clicks
SNMP Trap 1	-> 5 clicks
SNMP Trap 2	-> 6 clicks
SNMP	-> 7 clicks

6. DIAGNOSTICS

6.3.1 Setting Menu

Once an item to change a setting is selected in, it prints setting menu as follows.

This menu is to select a setting option of each setting by clicking the feed button followed by long press according to the menu guideline.

```
***** e.g. Code Page *****
To select an option, press the key by a
short press followed by a long press.

Sub Menu                -> No click
Setting option 1        -> 1 click
Setting option 2        -> 2 clicks
    ⋮                    ⋮
Setting option n        -> n clicks
```

6.3.2 Final Confirmation Menu

Once a setting option is selected in setting menu, it goes to each final confirmation menu as follows.

```
***** e.g. Code Page *****
850
Save the change          ->Long Press
Cancel the change       ->Short Press
```

This menu is to confirm if the change done on setting menu before it is stored into the non-volatile memory.

Long Press for 3 seconds

It saves the change into non-volatile memory and goes back to Main Menu.

Short Click

It cancels the change and goes back to the previous Setting Menu. If it is the final confirmation of “Reset to Default Setting”, it goes back to Top Menu without changing any settings.

6. DIAGNOSTICS

6.4 Printer Configuration Form

Printer Configuration Form indicates the individual information including its configurations.

Operations to print Printer Configuration Form are as follows.

1. The cover is closed after the printer beeps once.
2. "To Print Config. Form" in offline diagnostic is chosen
3. "Print Printer Configuration Form" command (0x1F 0x74) is received

Note: The printout should be similar to below but the setting and the content may vary depending on your printer setting.

Model number	: XXXX -XXXX-XXXX
Serial number	: 1234567890
Boot Firmware	: V00.11 / C79F
Main Firmware	: V00.30 / 765D
Table Firmware	: V00.20 / 10A9
Font (SBCS)	: V10.00 / 2020
Printer Settings	
Code Page	: 437
Font Size	: Font 2
Default LPI	: 6 LPI
Legacy Barcode	: Disabled
Carriage Return	: Use Cmd
Print Density	: 0
Power Supply	: 60W
Standby Mode	: Enabled
⋮	⋮
BM/GAP Error Recover	: Auto Measure
Power Up Top Feed	: Enabled
Paper Setting	
Media Type	: Linerless
Paper Type	: Predefined 8
Paper Mode	: Document
Paper Width	: 80mm
Paper Low Setting	
Paper Low Detection	: Enabled (15ft)
Paper Core diameter	: 29mm
Paper Thickness	: 0.145mm
Diameter Detection	: 0
Cleaning Setting	
Cleaning Reminder	: Disabled
Cleaning Interval	: 0 Cut
Maintenance Information	
	User Perm
Hours ON	: 00000000 / 00000000
FW Download	: 00000000 / 00000000
Print Length	: 00000000 / 00000000
Feed Length	: 00000000 / 00000000
Head over Heat	: 00000000 / 00000000
Knife Cut	: 00000000 / 00000000
Knife Jam	: 00000000 / 00000000
Cover Open	: 00000000 / 00000000
BM Error	: 00000000 / 00000000
Gap Error	: 00000000 / 00000000
Paper Guide Err	: 00000000 / 00000000
Warning Dots	: 000 dots ²
User Define Data in Flash Memory	
Logos	: NA
Characters	: NA
Macro	: NA
Sensor Level	
Black Mark	: 1.6V, 0.3V, 0.9V, 0.8V
Paper Gap	: 0.2V, 1.1V, 0.6V, 0.4V
Paper Gap Label	: 1.1V, 2.1V, 1.6V, 0.4V
Paper Taken	: 1.8V, 0.2V, 1.0V, 0.9V

² Before it prints Printer Configuration Form, it performs the head failure detection in order to update the status of each thermal head dot.

6. DIAGNOSTICS

When RS232 interface card is inserted to the printer, the following information is shown.

<u>RS232 Interface Settings</u>	
Baud Rate	: 19200
Data Bits	: 8
Stop Bits	: 1
Parity	: None
Flow Control	: DTR/DSR
Reception Errors	: Print “?”
DSR Signal	: Disable

When Ethernet interface card is inserted to the printer, the following information is shown.

<u>Ethernet Interface Settings</u>	
MAC address	: xx.xx.xx.xx.xx.xx
IP address	: 192.168.1.99
Subnet Mask	: 255.255.255.0
Default Gateway	: 0.0.0.0.
TCP Port Number	: 9100
UDP Port Number	: 3000
DHCP	: Enable
DHCP request address	: 192.168.2.1
Physical LAN Speed	: Auto
Link down Timeout	: 120 min
TCP Idle Timeout	: 2 min
SNMP	: Enable
SNMP Trap 1	: Disable
Trap 1 IP Address	: 192.168.1.111
SNMP Trap 2	: Disable
Trap 1 IP Address	: 192.168.1.222

7. GENERAL MAINTENANCE

6.5 Paper Setting

The printer has software setting function that allow user to configure various setting for printer. See the next section for an overview of paper printing related function.

6.5.1 Media Type

To select media in use.

- Receipt
- Linerless
- Label

6.5.2 Paper Type

To select Pre-defined paper parameter setting.

Media Type: Receipt	
Paper Type	Max Print Speed
Predefined 1	8 ips
Predefined 2	8 ips

Media Type: Linerless	
Paper Type	Max Print Speed
Predefined 1	6 ips
Predefined 2	6 ips
Predefined 3	6 ips
Predefined 4	6 ips
Predefined 5	6 ips
Predefined 6	4 ips
Predefined 7	4 ips
Predefined 8	6 ips
User-defined 4*	

Media Type: Label	
Paper Type	Max Print Speed
Predefined 1	8 ips
User-defined 1*	
User-defined 3*	

NOTE:

- Refer to APPENDIX B for recommended paper type setting for respective paper list.
- *User may customize printer parameters setting through Toshiba Utilities and save under “User-defined” type for respective Media type for quick set up in future.

7. GENERAL MAINTENANCE

6.5.3 Paper Mode

To select printer feed length and cutting control.

- Document Length: Cutter cutting based on data received.
- Black Mark: Cutter cutting at Black Mark.
- Gap: Cutter cutting at Label Gap. For Label Type selection only.

6.5.4 Paper Width

- 80 mm
- 58 mm
- 48 mm
- Auto (Printer detect paper width automatically)

6.5.5 Paper Low Detection

- Enable (40ft)
- Disabled
- Enable (30ft)
- Enable (20ft)
- Enable (15ft)

Note: Paper Low Detection available selection depends on paper type predefined parameters. Certain selection not available due to remaining paper calculation based on paper roll size.

6.6 Printer Maintenance

Printer Maintenance setting has selection to get maintenance information, change cleaning setting and make printer enter to cleaning mode.

6.6.1 Printer Maintenance QR

Maintenance QR consists of two 2D barcode that include various information related to the maintenance.

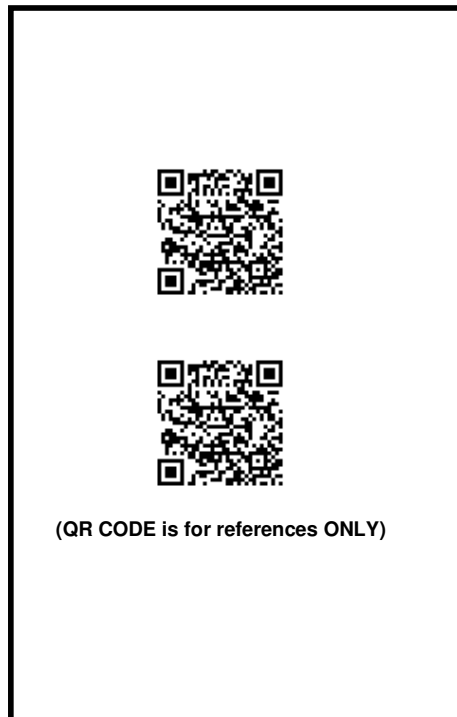

7. GENERAL MAINTENANCE

Operations to print Maintenance Information are as follows.

“To Print Maintenance Info.” in Offline Diagnostic is chosen

“Print Maintenance Information Form” command (0x1D 0x64 0x01) is received

Before it prints Maintenance Information Form, it performs the head failure detection in order to update the status of each thermal head dot.

Once Maintenance Information is printed out, Maintenance tally is increased. Apart from this, there are other conditions that Maintenance tally is counted up as follows. The update of Maintenance tally is only one time through each power-on regardless of a trigger.

- 1) At the timing of some tally information is reset.
- 2) At the timing of all the printer information / settings are reset by a command.
- 3) At the timing of sensor calibration.
- 4) At the timing of updating Printer Model Name, Serial Number

6.6.2 Cleaning Setting

Cleaning Setting allows you to configure the cleaning reminder, interval or enter to cleaning mode to perform cleaning operation.

- Cleaning Reminder
To configure the reminder method or disable it.
- Cleaning Interval
To set a reminder interval between Ten thousand cuts to One million cuts.
- Cleaning Mode
Printer enters cleaning mode, printer will extend Cutter moving blade for easy access for blade cleaning.

6.7 Other Software Setting

Other useful settings which can be configured through offline diagnostic form are listed below.

- Print Density
Adjustable range from
Default settings is 0

NOTE:

When higher print density is set, print speed may reduce depending on print content.

- Max. Print Speed
Adjustable range from 2ips to 8ips
(Default setting refer “Paper Type” mode predefined value)

NOTE:

Actual print speed may vary by condition, such as print duty, data transfer speed and print content.

7. GENERAL MAINTENANCE

- Max Barcode Speed
Adjustable range from 2ips to 8ips
(Default setting refer “Paper Type” mode predefined value)

NOTE:

Depending on Linerless Paper adhesive condition, higher print speed may cause white streak on printouts and affect barcode scan ability. It is recommended to check barcode scan ability before increase barcode speed.

- Knife Cut
 - Select by Command
 - Disabled
 - Partial Cut (Default)
- Paper Taken
 - Enabled (Default)
 - Disabled
- Buzzer Volume
To adjust buzzer loudness
 - Level 1
 - Level 2 (Default)
 - Level 3
- Buzzer Tone
To adjust buzzer sound pitch
 - Low
 - Middle (Default)
 - High
- Top Margin
Selectable from 4mm to 14mm (disabled)
Default Top Margin Setting is 4mm

7. GENERAL MAINTENANCE

⚠ WARNING!

Be sure to disconnect the power cord prior to performing any maintenance.
DO NOT POUR WATER directly onto the printer, as this may cause electric shock or fire.
The print head becomes very hot while printing. To avoid getting burned, never touch the print head during the maintenance.

⚠ CAUTION!

Do not use any sharp object to clean the print head and platen. Doing so may damage them, causing poor print or missing dots.
Never use an organic solvent like thinners or benzene for cleaning. Using such solvents may discolor the covers.
Do not touch the print head element as static built-up may damage the print head.

To help retain the high quality and performance of your printer it should be cleaned regularly. The greater the usage on the printer, the more frequent the cleaning. (i.e. low usage=weekly, high usage=daily)

7.1 Cleaning the Covers

Wipe the covers with a soft dry cloth or soft cloth slightly moistened with mild detergent. After using detergent for cleaning, be sure to wipe it off with a slightly moistened cloth.

7.2 Cleaning Mode

Printer software includes Cleaning, Mode, when printer enter Cleaning Mode, printer will extend Cutter Moving blade to allow easy access for Cleaning.

To enter Cleaning Mode through offline diagnostic, refer to section 6.6.2 Cleaning Setting.

When cleaning mode is selected, printer will print an illustration instruction to show the step for cleaning and Cutter moving blade will extend outward. Follow the instruction to open Front Cover first, then open the Top Cover.

Clean the Cutter Moving blade, Fix blade, Thermal Print Head and Sensor with cleaning pen. After cleaning is completed, close cover as sequence shown in instruction.

7. GENERAL MAINTENANCE

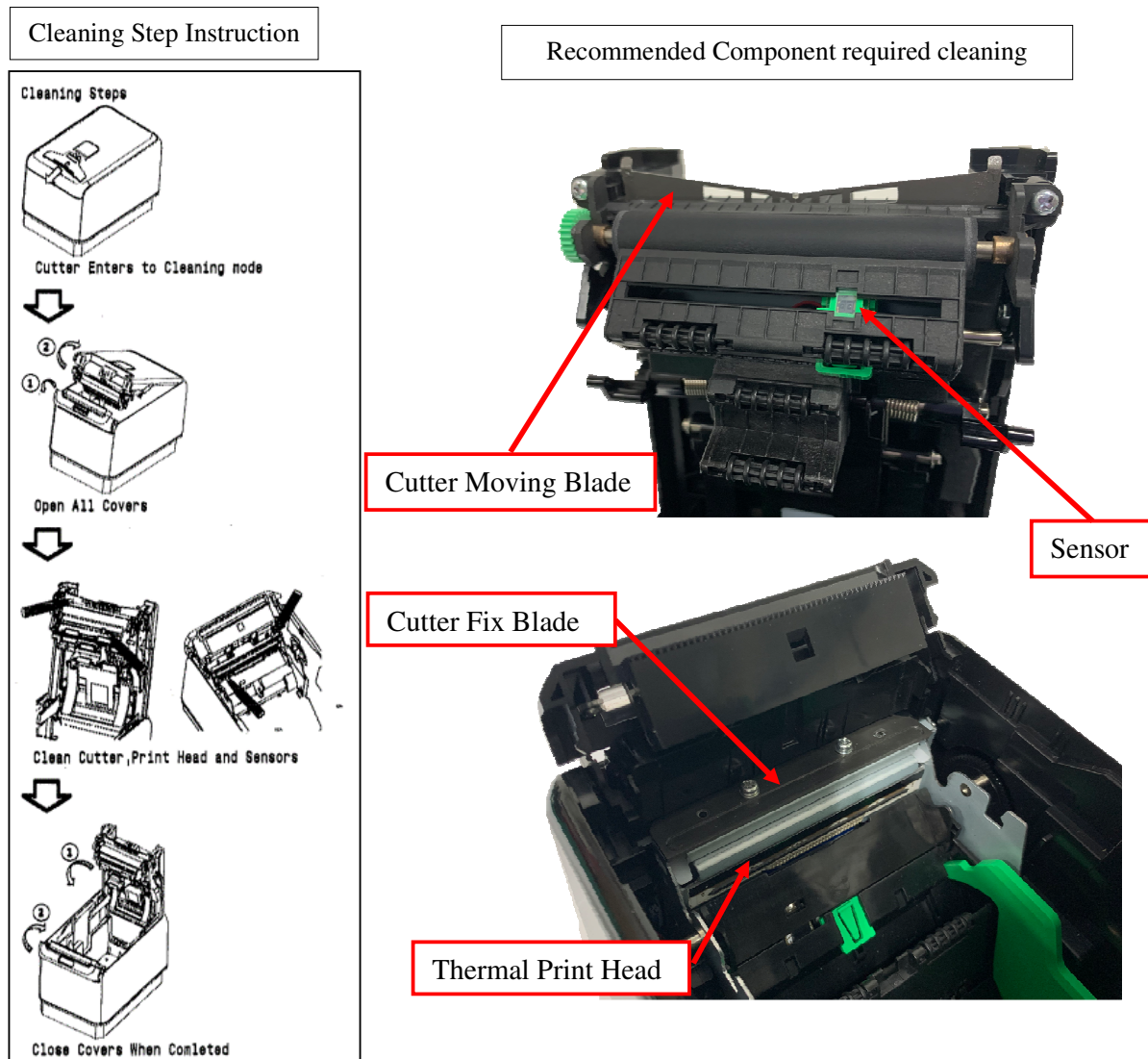

⚠ Caution!: Do not spray or try to clean the thermal print head or the inside of the printer with any kind of cleaner as this may damage the thermal print head and electronics. If the thermal print head appears dirty, clean it with cleaning pen or wipe it with cotton swabs and isopropyl alcohol.

Note: If non-recommended paper has been used for an extended period of time, cleaning the print head with cotton swabs and rubbing alcohol will not be of much benefit.

Recommended cleaning interval for Linerless Paper

- | | |
|------------------------------------|-----------------------------------|
| 1) Print head and Platen Roller | : 30 rolls or 3km |
| 2) Cutter | : 30 rolls or 40,000 cuts |
| 3) Print engine/paper path/sensors | : 30 rolls or 40,000 transactions |

Note: Calculation based on 106 meter per roll or 1300 transactions per roll.

8. TROUBLESHOOTING

⚠ WARNING!

If you cannot solve a problem with the following solutions, do not attempt to repair it by yourself. Turn the power supply off, unplug the printer, and then contact your authorized TOSHIBA TEC representative for assistance.

8.1 Removing Jammed Paper

- 1) When printer is jammed, the LED will show AMBER color with one blinks and Pause for 5seconds.
- 2) Open the printer cover.
- 3) Remove the jammed paper. **DO NOT USE** any sharp implement or tool as these will damage the printer.



- 4) Re-load the receipt roll. Refer to **Section 5.3 “Loading the Paper Roll”**.
- 5) Close the printer top cover and the printer will be ready to use.

8.2 Resetting Cutter Failure or Jam

1. When the cutter is jammed, the LED will show AMBER color with 2 blinks and Pause for 5 seconds.
2. Open the printer front cover by pulling on both sides as shown in the figure on the left.



3. Flip to fully open the front cover.



8. TROUBLESHOOTING

4. Flip to open the top cover.



5. Remove any jammed paper and paper roll out from the printer. DO NOT USE any sharp implement or tool as these will damage the printer.



6. Close the printer top cover A first. Then, close the printer front cover B. The printer cutter will reset to the original position.

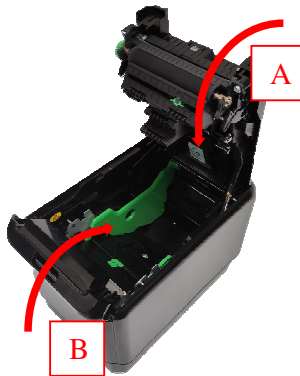

7. Then, Re-load the receipt roll. Refer to **Section 5.3 “Loading the Receipt Roll”** and the printer is ready to be use again.

8. TROUBLESHOOTING

8.3 Common Problems & Solutions

Power Supply Failure

Phenomenon	Cause	Check method	Solution
No power is supplied. (Power LED does not light.)	The power adapter DC cable is not connected to printer.	Check if the cable is connected properly.	Connect the specified power adapter DC cable to printer.
	The AC power cord is not connected to power adapter and wall outlet.	Check if the cable is connected properly.	Connect the AC power cord to power adapter and wall outlet.
	The wall outlet has problem.	If it is not a power failure, check if the power is supplied to the AC outlet with another electric appliance.	If not, contact your nearest power company.

Printing Failure

Phenomenon	Cause	Check method	Solution
Paper is not fed or is fed irregularly	The paper roll is not loaded properly	Check the paper roll if it is loaded properly.	Refer to Section 5.3 “Loading the Paper Roll” and load the receipt roll properly
	The top or front covers is not closed properly	Check if the LED status (refer to Section 8.4 “LED Indication Table”) and the covers.	Close top cover and front cover properly.
	The paper is jammed	Check if the LED status (refer to Section 8.4 “LED Indication Table”) and whether the paper is jammed or torn and caught in the paper path.	Remove jammed paper from the paper path and set the paper properly.
No Printing when print job is sent from POS terminal	Interface cable is not connected properly	Check if the offline diagnostic printing work correctly. If yes, check the interface cable connection.	Connect the interface cable properly. Refer to Section 5.1 “Connecting the Power Cord and Interface Cable” .
Void Printing (Paper comes out, but no characters are printed on the paper)	Wrong type of media inserted.	Check if the media is thermal.	Use the specified media.
	Paper Roll inserted wrongly.	Thermal coating should be in contact with printer head.	Insert correctly the paper roll. Refer to Section 5.3 “Loading the Paper Roll” .

8. TROUBLESHOOTING

Printing Failure

Phenomenon	Cause	Check method	Solution
Blurred or uneven print	Foreign object is attached to the print head.	Check whether any foreign objects are attached to the print head.	Clean print head with cotton swab or soft cloth slightly moistened with ethyl alcohol. Refer to Section 7.2 “Cleaning Mode” .
	Non recommended type of media loaded	Check if the media is of recommended type	Contact the TOSHIBA TEC’s dealer for the recommended paper
	Faulty print head.	Check print head health if it is showing any warning dots. Refer to Section 6.4 “Printer Configuration Form”	Contact TOSHIBA TEC’s dealer for service.

Cash Drawer Failure

Phenomenon	Cause	Check method	Solution
Cash drawer cannot be opened	The cash drawer cable is not connected properly	Check if the cash drawer cable is connected properly to the printer and cash drawer	Connect the cable properly. Refer to Section 5.1.5 “Connecting via Cash Drawer”
	Incorrect cable is used	Check if the cable specification is meeting the requirement. Refer to Section 3.4 “Specification of Interface & Power Connector”	Use the cable which meets the specification.
	Cash drawer open function is not enabled in POS terminal	Check the setting in the POS terminal	Make sure the function is enabled in the POS terminal.

NOTE: If any problem occurs other than the above, please contact your authorized TOSHIBA TEC representative.

8. TROUBLESHOOTING

8.4 LED Indication Table

Printer Status	Cycle	Color	Control	Buzzer	What to Do	Where to Go
Boot Up	NA	BLUE =>AMBER =>BLUE => OFF	ON	OFF		
Idle	NA	BLUE	ON	OFF		
Printing	1 Hz	BLUE	ON	OFF		
Firmware Update (Online / Offline / IPL)	3 Hz	BLUE	Constant Blink	OFF		
Offline Diagnostics	3 Hz	BLUE	Constant Blink	Beep according to the feed button click Operation		
Unrecoverable error: Thermal Head Abnormal Temperature	2 Hz	AMBER	3 Blinks Pause 3 seconds	Beep continuously	Turn off the printer for 5minutes to cool down the printer.	
Unrecoverable error: Memory Error	2 Hz	AMBER	4 Blinks Pause 3 seconds	Beep continuously	Power cycle to check if the printer recovers	
Recoverable error: Paper End	NA	AMBER	ON	Beep continuously	Change the paper now. Do not run a transaction without paper as the data may be lost.	See Section 5.3. “Loading the Receipt Roll”
Recoverable error: Cover Open	NA	AMBER	ON	OFF	Close the cover. The printer will not operate with the cover open.	
Recoverable error: Thermal Head Over Heat	1 Hz	AMBER	Constant Blink	Beep continuously	Wait for 10 seconds and the printer will resume printing	
Recoverable error: Cutter Jam	2 Hz	AMBER	2 Blinks Pause 3 seconds	Beep continuously	Open the receipt front cover first, then follow by top cover and check for the cutter. Clear any jammed paper you can see. Tear off any excess paper against the tear-off blade.	See Section 8.2 “Resetting Cutter Failure or Jam”
Recoverable error: Black Mark Error	2 Hz	AMBER	5 Blinks Pause 3 seconds	Beep continuously	1) If non-black mark paper is loaded, change paper with black mark	
					2) If black mark is loaded, shift black mark sensor to match with paper black mark position	See Section 5.5 “Black Mark Sensor Configuration”

8. TROUBLESHOOTING

					3) If intend to use non-black mark paper, change Paper Mode to "Document Length"	See Section 6.5.3 "Paper Mode"
Recoverable error: Gap Error	2 Hz	AMBER	6 Blinks Pause 3 seconds	Beep continuously	1) Shift black mark sensor to label gap detection position.	See Section 5.5 "Black Mark Sensor Configuration"
					2) If loaded paper is not label paper, change paper roll to label paper	
					3) If not using label media, change Paper Mode to "Document Length" or "Black Mark" mode depends on actual paper used.	See Section 6.5.3 "Paper Mode"
Recoverable error: Paper Guide Error	2 Hz	AMBER	7 Blinks Pause 3 seconds	Beep continuously	Change paper guide configuration according to paper width used.	See Section 5.4 "Changing Paper Guiding Width"
Warning: Paper is remaining on exit area	2 Hz	BLUE	Constant Blink	Beep continuously	Remove the remaining paper at exit area	
Warning: Paper Low	1 Hz	BLUE	Constant Blink	OFF	There are about 4.5 meters, \pm 3 meters (15 feet, \pm 10 feet) of paper left. Change the paper soon to avoid running out of paper part way through a transaction. * Remaining length value for Paper Low detection is adjustable between 15 feet (default), 20 feet, 30 feet and 40 feet. Refer to Owner Manual for Paper Low Detection setting adjustment.	See Section 5.3. "Loading the Receipt Roll" See Section 6.5.5 "Paper Low Detection"

NOTE: If other LED status except for the above occurs, turn the power supply off, and then reopen. If this does not restore the LED, contact your nearest TOSHIBA TEC representative for assistance.

9. APPENDIX A

9.1 Ethernet

Ethernet interface is available when Ethernet option card is connected to printer.

9.2 Password Registration

The printer rejects all data / commands via Ethernet interface unless an end user specifies their own password of Web setting

However, even if the password is not properly specified yet, it is able to Links-Up. Printer prints the following message once it links-up.



Printer web setting link in the warning print “<http://xxx.xxx.xxx.xxx/index.html>” the address is based on printer IP address. QR code content is the same as printer access link. Printer requires password registration as follows when the web setting page is opened at the very beginning.

Warning

This printer is not configure yet. If the credential is not setup properly, the printer will reject all data from any host through LAN (TCP/UDP).

Please specify a password to access Web setting.

Your password:

- Must contain at least 4 characters.
- Must not contain more than 16 characters.
- Must contain only alphanumeric characters.

9.3 Web Setting Page

Printer supports setting change via web page.

It requires “User name” and “Password” to login web setting page.

[IP]		
IP Address	192 168 1 99	Value(0-255): Valid address
Subnet Mask	255 255 255 0	Value(0-255): Valid Mask
Default Gateway	0 0 0 0	Value(0-255): Valid address
DHCP	Enabled ▾	Select option
DHCP Request IP Address	0 0 0 0	Value(0-255): Valid address
Host Name		Maximum 16 character

- IP Address : IP address for DHCP “Disable”
- Subnet mask : Subnet mask setting
- Default gateway : default gateway setting
- DHCP : DHCP enable/disable option
- DHCP request IP : IP address request for DHCP
- Host name : Printer host name.

[TCP/UDP]		
Number of TCP Connections	6	Value(1-6)
Time of Time-out (for Link Down)	120	Value(1-120 minutes) : 0=No timeout
Time of Time-out (for Idle)	2	Value(1-120 minutes) : 0=No timeout
TCP port	9100	Value(1024-65535)
UDP port	3000	Value(1024-65535)

- Number of TCP connection : Maximum number of TCP connection
- Time out. (link down) : Time out for TCP port close by Link down. (1-120 minutes)
- Time out. (Idle) : Time out for TCP port close by idle. (1-120 minutes)
- TCP port : Port number for TCP communication.
- UDP port : Port number for UDP communication.

[Ethernet]		
MAC Address	00-80-91-e1-00-00	Unchangeable
Physical Layer	Auto ▾	Select option

- MAC address : MAC address.
- Physical layer : Auto / 100Mbps full / 100Mbps Half / 10Mbps full / 10Mbps Half

[User/Password]		
User	admin	Maximum 16 character
Password	•••••	Maximum 16 character

- User : User name to login web setting page.
- Password : Password to login web setting page.

SNMP – Configuration

[Community]		
SNMP	Enabled ▼	Select option
Read Only	public	Unchangeable
Read/Write	<input type="text"/>	Maximum 16 character

[SNMP Trap1]		
TRAP	Disabled ▼	Select option
IP Address	<input type="text" value="0"/> <input type="text" value="0"/> <input type="text" value="0"/> <input type="text" value="0"/>	Value(0-255): Valid address
Community Name	<input type="text"/>	Maximum 16 character

[SNMP Trap2]		
TRAP	Disabled ▼	Select option
IP Address	<input type="text" value="0"/> <input type="text" value="0"/> <input type="text" value="0"/> <input type="text" value="0"/>	Value(0-255): Valid address
Community Name	<input type="text"/>	Maximum 16 character

- SNMP : “Enable”, “Disable” SNMP functionality.
- Read/Write : Community name for SNMP.
- TRAP 1 : “Enable” “Disable” for TRAP 1.
- IP address : IP address for Trap 1
- Community name : Community name for Trap1
- TRAP 1 : Enable” “Disable” for TRAP 2.
- IP address : IP address for Trap 2
- Community name : Community name for Trap2

9.4 Reset Password

Printer resets password in the following cases

- Factory default by Printer setting change command. (1F 36 m n FF)
- Factory default by offline diagnostic.
- Delete password by web setting page.

Once password is reset, Ethernet is invalid unless the password is registered again. Please refer to **Section 9.2 “Password Registration”**.

10. APPENDIX B

10.1 Reference List of Tested Linerless Paper

Media type selection: Linerless

Maker	Product Line	Product / Part Number	Paper Width	TRST-L1	Paper Type
Iconex	Ultralite	9023-2150/9023-0205	40mm	√*	2
		9023-2431	58mm	√*	2
		9023-2244/9023-9317	80mm	√*	2
		9023-0085	80mm	√*	2
	G2	9023-2634	58mm	√*	2
		9023-2663	80mm	√*	2
	Full Tack	9023-1873/9023-1708	40mm	√*	3
		9023-2242	58mm	√*	3
		9023-2243	58mm	√*	3
		9023-2240	80mm	√	3
		9023-2241	80mm	√*	3
	Extreme	9023-0075/9023-3301	40mm	√	3
		9023-3303	58mm	√*	3
		9023-0088	80mm	√*	3
	Bag Label	9023-4188	80mm	√*	2
MAXStick	2GO	9023-0273	80mm	√*	5
	2GO PLUS D	9023-0264	58mm	√	5
		9023-0242	80mm	√*	5
	PLUS D	9023-0265	58mm	√*	5
		9023-0287	80mm	√*	5
	X2	9023-3375	58mm	√*	4
9023-3378		80mm	√	4	
StickyPOS	BT	BT40X270	40mm	√*	6
		BT58X270	58mm	√*	6
		BT80X270	80mm	√	6
	HTFC10	HTFC10 40X270	40mm	√*	8
		HTFC10 58X270	58mm	√*	8
		HTFC10 80X270	80mm	√	8

√	Papers tested for Print Quality & Reliability
√*	Papers tested for Print Quality

- Notes: 1) These Linerless paper adhesive type and pattern may cause print quality such as white streak or disturbance in the line pitch due to the peeling force of the paper.
- 2) This Linerless paper is sensitive to heat, if paper left in printer for long time or continuously printing high density print, the linerless paper may stick to print head, it may cause irregular paper feeding, compress print or paper jams. If issue occur, increase interval between transaction to avoid heat accumulation at print head.

10.2 Reference List of Tested Receipt Paper

Media Type Selection: Receipt

Maker	Grade	TRST-L1	Paper Type
Nippon Paper Industries	TF50KS-EY	√	1
Koehler	KT75 FA	√*	3

√	Papers tested for Print Quality & Reliability
√*	Papers tested for Print Quality

10.3 Reference List of Tested Label Paper

Media Type Selection: Label

Maker	Grade	TRST-L1	Paper Type
LINTEC	DT PW-7 6K	√*	1

√	Papers tested for Print Quality & Reliability
√*	Papers tested for Print Quality

11. APPENDIX C

11.1 Black Mark Specification

General requirements

- Black mark sensor position: Non Coating side of Media
- Black marks should be consistent in darkness
- Transmittance: 15% or less
- Oil-based ink should be used. (Surface should not be glossy but matte.)
- Reflectance: PCS 0.7 or more
- Accumulated pitch tolerances of the black dots are max. ± 0.3 for two pitches.
- In case of pre-printing outside the specified area, the PCS value must be lower than 0.4

Black Mark position criteria

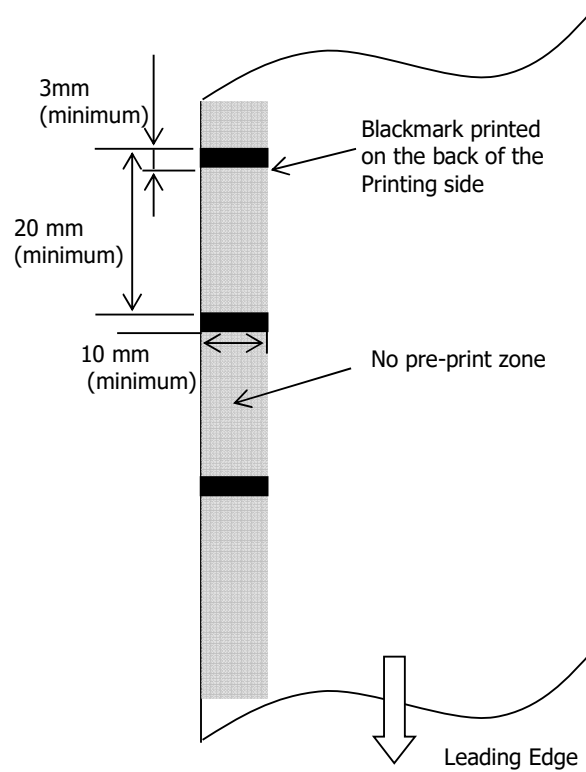

Unit: mm

12. APPENDIX D

12.1 Liner Label Specification

General Requirements

- Label backings are certified in pairs with labels.
- Label backing should be grassine paper 7K or 8K white or equivalent.

Media Size and Shape

