



# ThinkSystem SR630 V3 System Configuration Guide



**Machine Types:** 7D72, 7D73, 7D74

## Note

Before using this information and the product it supports, be sure to read and understand the safety information and the safety instructions, which are available at:

[https://pubs.lenovo.com/safety\\_documentation/](https://pubs.lenovo.com/safety_documentation/)

In addition, be sure that you are familiar with the terms and conditions of the Lenovo warranty for your server, which can be found at:

<http://datacentersupport.lenovo.com/warrantylookup>

**Tenth Edition (August 2024)**

**© Copyright Lenovo 2023, 2024.**

LIMITED AND RESTRICTED RIGHTS NOTICE: If data or software is delivered pursuant to a General Services Administration "GSA" contract, use, reproduction, or disclosure is subject to restrictions set forth in Contract No. GS-35F-05925.

---

# Contents

<b>Contents</b> . . . . .	<b>i</b>	Identify the server and access the Lenovo XClarity Controller . . . . .	73
<b>Safety</b> . . . . .	<b>.iii</b>	Server setup checklist . . . . .	75
Safety inspection checklist . . . . .	iv	<b>Chapter 5. System configuration</b> . . . . .	<b>77</b>
<b>Chapter 1. Introduction</b> . . . . .	<b>1</b>	Set the network connection for the Lenovo XClarity Controller . . . . .	77
Features. . . . .	1	Set USB port for Lenovo XClarity Controller connection. . . . .	78
Tech Tips . . . . .	3	Update the firmware . . . . .	79
Security advisories . . . . .	3	Configure the firmware . . . . .	82
Specifications . . . . .	3	Enable Software Guard Extensions (SGX). . . . .	83
Technical specifications. . . . .	4	RAID configuration . . . . .	84
Mechanical specifications . . . . .	12	Deploy the operating system. . . . .	85
Environmental specifications . . . . .	12	Back up the server configuration . . . . .	86
Management options. . . . .	18	Enable Intel® On Demand . . . . .	86
Enable Intel® On Demand Troubleshooting . . . . .	96	<b>Appendix A. Getting help and technical assistance</b> . . . . .	<b>97</b>
<b>Chapter 2. Server components</b> . . . . .	<b>23</b>	Before you call . . . . .	97
Front view . . . . .	23	Collecting service data . . . . .	98
Rear view . . . . .	31	Contacting Support . . . . .	99
Top view . . . . .	36	<b>Appendix B. Documents and supports</b> . . . . .	<b>101</b>
Top view with standard heat sinks . . . . .	36	Documents download . . . . .	101
Top view with liquid to air module . . . . .	38	Support websites . . . . .	101
Top view with direct water cooling module . . . . .	38	<b>Appendix C. Notices.</b> . . . . .	<b>103</b>
Front I/O module . . . . .	39	Trademarks . . . . .	104
System-board-assembly layout . . . . .	41	Important notes. . . . .	104
System-board-assembly connectors. . . . .	42	Electronic emission notices . . . . .	104
System-board-assembly switches. . . . .	44	Taiwan Region BSMI RoHS declaration . . . . .	105
System LEDs and diagnostics display . . . . .	46	Taiwan Region import and export contact information . . . . .	105
Troubleshooting by system LEDs and diagnostics display. . . . .	46		
<b>Chapter 3. Parts list</b> . . . . .	<b>69</b>		
Power cords . . . . .	72		
<b>Chapter 4. Unboxing and setup</b> . . . . .	<b>73</b>		
Server package contents . . . . .	73		



---

## Safety

Before installing this product, read the Safety Information.

قبل تركيب هذا المنتج، يجب قراءة الملاحظات الأمنية

Antes de instalar este produto, leia as Informações de Segurança.

在安装本产品之前，请仔细阅读 Safety Information（安全信息）。

安裝本產品之前，請先閱讀「安全資訊」。

Prije instalacije ovog produkta obavezno pročitajte Sigurnosne Upute.

Před instalací tohoto produktu si přečtěte příručku bezpečnostních instrukcí.

Læs sikkerhedsforskrifterne, før du installerer dette produkt.

Lees voordat u dit product installeert eerst de veiligheidsvoorschriften.

Ennen kuin asennat tämän tuotteen, lue turvaohjeet kohdasta Safety Information.

Avant d'installer ce produit, lisez les consignes de sécurité.

Vor der Installation dieses Produkts die Sicherheitshinweise lesen.

Πριν εγκαταστήσετε το προϊόν αυτό, διαβάστε τις πληροφορίες ασφαλείας (safety information).

לפני שתתקינו מוצר זה, קראו את הוראות הבטיחות.

A termék telepítése előtt olvassa el a Biztonsági előírásokat!

Prima di installare questo prodotto, leggere le Informazioni sulla Sicurezza.

製品の設置の前に、安全情報をお読みください。

본 제품을 설치하기 전에 안전 정보를 읽으십시오.

Пред да се инсталира овој продукт, прочитајте информацијата за безбедност.

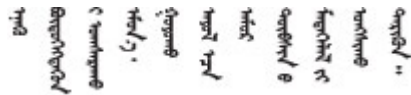

Les sikkerhetsinformasjonen (Safety Information) før du installerer dette produktet.

Przed zainstalowaniem tego produktu, należy zapoznać się z książką "Informacje dotyczące bezpieczeństwa" (Safety Information).

Antes de instalar este produto, leia as Informações sobre Segurança.

Перед установкой продукта прочтите инструкции по технике безопасности.

Pred inštaláciou tohto zariadenia si pečítajte Bezpečnostné predpisy.

Pred namestitvijo tega proizvoda preberite Varnostne informacije.

Antes de instalar este producto, lea la información de seguridad.

Läs säkerhetsinformationen innan du installerar den här produkten.

ཐོན་ཁུངས་འདི་བདེ་སྤྱོད་མ་བྱས་གོང་། སྐྱོར་གྱི་ཡིད་གཟབ་  
བྱ་འདྲ་མིན་ཡིད་པའི་འོད་ཟེར་བལྟ་དགོས།

Bu ürünü kurmadan önce güvenlik bilgilerini okuyun.

مەزكۇر مەھسۇلاتنى ئورنىتىشتىن بۇرۇن بىخەتەرلىك ئۇچۇرلىرىنى ئوقۇپ چىقىڭ.

Youq mwngz yungh canjbinj neix gaxgonq, itdingh aeu doeg aen  
canjbinj soengq cungj vahgangj ancien siusik.

---

## Safety inspection checklist

Use the information in this section to identify potentially unsafe conditions with your server. As each machine was designed and built, required safety items were installed to protect users and service technicians from injury.

**Note:** The product is not suitable for use at visual display workplaces according to §2 of the Workplace Regulations.

**Note:** The set-up of the server is made in the server room only.

### CAUTION:

**This equipment must be installed or serviced by trained personnel, as defined by the NEC, IEC 62368-1 & IEC 60950-1, the standard for Safety of Electronic Equipment within the Field of Audio/Video, Information Technology and Communication Technology. Lenovo assumes that you are qualified in the servicing of equipment and trained in recognizing hazards energy levels in products. Access to the equipment is by the use of a tool, lock and key, or other means of security, and is controlled by the authority responsible for the location.**

**Important:** Electrical grounding of the server is required for operator safety and correct system function. Proper grounding of the electrical outlet can be verified by a certified electrician.

Use the following checklist to verify that there are no potentially unsafe conditions:

1. If your working condition necessitates the server being powered off or you intend to power off, make sure that the power cord is disconnected.

### S002



### CAUTION:

**The power-control button on the device and the power switch on the power supply do not turn off the electrical current supplied to the device. The device also might have more than one power cord. To remove all electrical current from the device, ensure that all power cords are disconnected from the power source.**

**Note:** Under certain circumstances, powering off the server is not a prerequisite. Refer to the precautions before conducting any tasks.

2. Check the power cord.

- Make sure that the third-wire ground connector is in good condition. Use a meter to measure third-wire ground continuity for 0.1 ohm or less between the external ground pin and the frame ground.
- Make sure that the power cord is the correct type.

To view the power cords that are available for the server:

a. Go to:

<http://dcsc.lenovo.com/#/>

b. Click **Preconfigured Model** or **Configure to order**.

c. Enter the machine type and model for your server to display the configurator page.

d. Click **Power → Power Cables** to see all line cords.

- Make sure that the insulation is not frayed or worn.

3. Check for any obvious non-Lenovo alterations. Use good judgment as to the safety of any non-Lenovo alterations.

4. Check inside the server for any obvious unsafe conditions, such as metal filings, contamination, water or other liquid, or signs of fire or smoke damage.

5. Check for worn, frayed, or pinched cables.

6. Make sure that the power-supply cover fasteners (screws or rivets) have not been removed or tampered with.



---

## Chapter 1. Introduction

The ThinkSystem SR630 V3 server (7D72, 7D73, 7D74) is a high-performance, multi-core 1U rack server designed to support many kinds of Information Technology (IT) workloads with high agility. It carries the most advanced processing and memory units and can scale up to the state-of-the-art liquid cooling solutions. This server is ideally suited for IT environments that require superior processor performance, flexible manageability, and thermal efficiency.

Figure 1. ThinkSystem SR630 V3



---

## Features

Performance, ease of use, reliability, and expansion capabilities are key considerations in the design of your server. These design features make it possible for you to customize the system hardware to meet your needs today, and provide flexible expansion capabilities for the future.

Your server implements the following features and technologies:

- **Features on Demand**

If a Features on Demand feature is integrated in the server or in an optional device that is installed in the server, you can purchase an activation key to activate the feature. For information about Features on Demand, see:

<https://fod.lenovo.com/lkms>

Intel® On Demand is a feature that allows user to customize processor capabilities according to workload and tasks at hand. For more information, see “Enable Intel® On Demand” in *User Guide*.

- **Lenovo XClarity Controller (XCC)**

The Lenovo XClarity Controller is the common management controller for Lenovo ThinkSystem server hardware. The Lenovo XClarity Controller consolidates multiple management functions in a single chip on the server system board (system board assembly). Some of the features that are unique to the Lenovo XClarity Controller are enhanced performance, higher-resolution remote video, and expanded security options.

The server supports Lenovo XClarity Controller 2 (XCC2). For additional information about Lenovo XClarity Controller 2 (XCC2), refer to <https://pubs.lenovo.com/lxcc-overview/>.

- **UEFI-compliant server firmware**

Lenovo ThinkSystem firmware is Unified Extensible Firmware Interface (UEFI) compliant. UEFI replaces BIOS and defines a standard interface between the operating system, platform firmware, and external devices.

Lenovo ThinkSystem servers are capable of booting UEFI-compliant operating systems, BIOS-based operating systems, and BIOS-based adapters as well as UEFI-compliant adapters.

**Note:** The server does not support Disk Operating System (DOS).

- **Active Memory**

The Active Memory feature improves the reliability of memory through memory mirroring. Memory mirroring mode replicates and stores data on two pairs of DIMMs within two channels simultaneously. If a failure occurs, the memory controller switches from the primary pair of memory DIMMs to the backup pair of DIMMs.

- **Large system-memory capacity**

The server supports synchronous dynamic random-access memory (SDRAM) registered dual inline memory modules (DIMMs) with error correcting code (ECC). For more information about the specific types and maximum amount of memory, see [“Technical specifications” on page 4](#).

- **Integrated network support**

The server comes with an integrated 1-port Gigabit Ethernet controller with an RJ-45 connector, which supports connection to a 1000 Mbps network.

- **Large data-storage capacity and hot-swap capability**

With the hot-swap feature, you can add, remove, or replace hard disk drives without turning off the server.

Storage capacity is different depending on server models. See [“Technical specifications” on page 4](#) for more information.

- **Lightpath Diagnostics**

Lightpath Diagnostics provides LEDs to help you diagnose problems. For more information about the Lightpath Diagnostics, see [“System LEDs and diagnostics display” on page 46](#).

- **Mobile access to Lenovo Service Information website**

The server provides a QR code on the system service label, which is on the cover of the server, that you can scan using a QR code reader and scanner with a mobile device to get quick access to the Lenovo Service Information website. The Lenovo Service Information website provides additional information for parts installation, replacement videos, and error codes for server support.

- **Active Energy Manager**

Lenovo XClarity Energy Manager is a power and temperature management solution for data centers. You can monitor and manage the power consumption and temperature of Converged, NeXtScale, System x, and ThinkServer servers, and improve energy efficiency using Lenovo XClarity Energy Manager.

- **Redundant networking connection**

The Lenovo XClarity Controller provides failover capability to a redundant Ethernet connection with the applicable application installed. If a problem occurs with the primary Ethernet connection, all Ethernet traffic that is associated with the primary connection is automatically switched to the optional redundant Ethernet connection. If the applicable device drivers are installed, this switching occurs without data loss and without user intervention.

- **Redundant cooling**

The redundant cooling by the fans in the server enables continued operation if one of the fan rotors fails. See “Thermal rules” in *User Guide* or *Hardware Maintenance Guide* for more information.

- **ThinkSystem RAID support**

The ThinkSystem RAID adapter provides hardware redundant array of independent disks (RAID) support to create configurations. The standard RAID adapter provides RAID levels 0, 1, and 10. Optional RAID adapter with RAID 5, 50, 6, and 60 is available for purchase.

---

## Tech Tips

Lenovo continually updates the support website with the latest tips and techniques that you can use to solve issues that your server might encounter. These Tech Tips (also called retain tips or service bulletins) provide procedures to work around issues or solve problems related to the operation of your server.

To find the Tech Tips available for your server:

1. Go to <http://datacentersupport.lenovo.com>, and input the model name or machine type of your server in the search bar to navigate to the support page.
2. Click on **How To's** from the navigation pane.
3. Click **Article Type** → **Solution** from the drop-down menu.

Follow the on-screen instructions to choose the category for the problem that you are having.

---

## Security advisories

In order to protect our customers and their data, Lenovo is committed to developing products and services that adhere to the highest security standards. When potential vulnerabilities are reported, it is the responsibility of the Lenovo Product Security Incident Response Team (PSIRT) to investigate and provide information to our customers so that they may put mitigation plans in place as we work toward providing solutions.

The list of current advisories is available at the following site:

[https://datacentersupport.lenovo.com/product\\_security/home](https://datacentersupport.lenovo.com/product_security/home)

---

## Specifications

Summary of the features and specifications of the server. Depending on the model, some features might not be available, or some specifications might not apply.

Refer to the below table for specifications categories and the content of each category.

Specification category	Technical specifications	Mechanical specifications	Environmental specifications
<b>Content</b>	<ul style="list-style-type: none"> <li>• Processor</li> <li>• Memory</li> <li>• Internal drives</li> <li>• Expansion slots</li> <li>• Graphics processing units (GPU)</li> <li>• Integrated functions and I/O connectors</li> <li>• Network</li> <li>• Rear button</li> <li>• RAID adapter</li> <li>• Host bus adapter</li> <li>• System fan</li> <li>• Electrical input</li> <li>• Minimal configuration for debugging</li> <li>• Operating systems</li> </ul>	<ul style="list-style-type: none"> <li>• Dimension</li> <li>• Weight</li> </ul>	<ul style="list-style-type: none"> <li>• Acoustical noise emissions</li> <li>• Ambient temperature management</li> <li>• Environmental</li> </ul>

## Technical specifications

Summary of the technical specifications of the server. Depending on the model, some features might not be available, or some specifications might not apply.

- [“Processor” on page 5](#)
- [“Memory” on page 6](#)
- [“Internal drives” on page 7](#)
- [“Expansion slots” on page 7](#)
- [“Graphics processing unit \(GPU\)” on page 8](#)
- [“Integrated functions and I/O connectors” on page 8](#)
- [“Network” on page 8](#)
- [“Rear button” on page 8](#)
- [“RAID adapter” on page 9](#)
- [“Host bus adapter” on page 10](#)
- [“System fan” on page 10](#)
- [“Electrical input” on page 11](#)
- [“Minimal configuration for debugging” on page 11](#)
- [“Operating systems” on page 12](#)

## Processor

### Processor

Supports multi-core Intel Xeon® processors, with integrated memory controller and Intel Mesh UPI (Ultra Path Interconnect) topology.

- Up to two 4th (Sapphire Rapids, SPR) or 5th Gen (Emerald Rapids, EMR) Intel Xeon scalable processors with the new LGA 4677 socket
- Up to 60 cores per socket for SPR processors and 64 cores per socket for EMR processors
- Up to 4 UPI links at up to 16 GT/s for SPR processors and 20 GT/s for EMR processors
- Thermal Design Power (TDP): up to 350 watts for SPR and 385 watts for EMR processors

**Note:** EMR processors with U suffix only support one-processor configurations. The maximum quantity supported is one.

For a list of supported processors, see: <https://serverproven.lenovo.com>.

## Memory

### Memory

See “Memory module installation order” in *User Guide* or *Hardware Maintenance Guide* for detailed information about memory configuration and setup.

- Slots: 32 dual inline memory module (DIMM) connectors that support up to 32 TruDDR5 DIMMs
- Memory module types for SPR processors:
  - TruDDR5 4800 MHz RDIMM: 16 GB (1Rx8), 32 GB (2Rx8), 48 GB (2Rx8)
  - TruDDR5 4800 MHz 10x4 RDIMM: 32 GB (1Rx4), 64 GB (2Rx4), 96 GB (2Rx4)
  - TruDDR5 4800 MHz 9x4 RDIMM: 32 GB (1Rx4), 64 GB (2Rx4)
  - TruDDR5 4800 MHz 3DS RDIMM: 128 GB (4Rx4), 256 GB (8Rx4)
- Memory module types for EMR processors:
  - TruDDR5 5600 MHz RDIMM: 16 GB (1Rx8), 24 GB (1Rx8), 32 GB (2Rx8), 48 GB (2Rx8)
  - TruDDR5 5600 MHz 10x4 RDIMM: 32 GB (1Rx4), 48 GB (1Rx4), 64 GB (2Rx4), 96 GB (2Rx4)
  - TruDDR5 5600 MHz 3DS RDIMM: 128 GB (4Rx4)
  - TruDDR5 5600 MHz Performance + RDIMM: 32 GB (2Rx8), 64 GB (2Rx4 10x4)
- Speed: Operating speed depends on processor model and UEFI settings.
  - 4800 MHz RDIMMs:
    - 1 DPC: 4800 MT/s
    - 2 DPC: 4400 MT/s
  - 5600 MHz RDIMMs:
    - 1 DPC: 5600 MT/s
    - 2 DPC:
      - 4800 MT/s for Performance + RDIMMs
      - 4400 MT/s
- Minimum memory: 16 GB
- Maximum memory: 8 TB: 32 x 256 GB 3DS RDIMMs

#### Notes:

- SPR processors (4510, 4509Y, 3508U, 4510T) and VRAN support 4800 MHz RDIMMs.
- EMR processors only support 5600 MHz RDIMMs.

For a list of supported memory options, see <https://serverproven.lenovo.com>.

For technical rules for memory modules, see “Memory module installation order” in *User Guide* or *Hardware Maintenance Guide*.

## Internal drives

Internal drives
<p>Front:</p> <ul style="list-style-type: none"><li>• Up to four 3.5-inch hot-swap SAS/SATA drives</li><li>• Up to four 3.5-inch hot-swap AnyBay (SAS/SATA/NVMe) drives</li><li>• Up to four 2.5-inch hot-swap SAS/SATA drives</li><li>• Up to four 2.5-inch hot-swap NVMe drives</li><li>• Up to eight 2.5-inch hot-swap SAS/SATA drives</li><li>• Up to six 2.5-inch hot-swap SAS/SATA and four 2.5-inch hot-swap AnyBay (SAS/SATA/NVMe) drives</li><li>• Up to six 2.5-inch hot-swap SAS/SATA and two 2.5-inch hot-swap AnyBay (SAS/SATA/NVMe) and two 2.5-inch hot-swap NVMe drives</li><li>• Up to ten 2.5-inch hot-swap SAS/SATA drives</li><li>• Up to eight 2.5-inch hot-swap NVMe drives</li><li>• Up to ten 2.5-inch hot-swap NVMe drives</li><li>• Up to ten 2.5-inch hot-swap AnyBay (SAS/SATA/NVMe) drives</li><li>• Up to 16 hot-swap EDSFF drives</li></ul> <p>Inside:</p> <ul style="list-style-type: none"><li>• Up to two internal SATA or NVMe M.2 drives</li></ul> <p>Rear:</p> <ul style="list-style-type: none"><li>• Up to two 2.5-inch hot-swap SAS/SATA or NVMe drives</li><li>• Up to two 7mm hot-swap SATA or NVMe drives</li></ul> <p><b>Notes:</b></p> <ul style="list-style-type: none"><li>• M.2 and 7mm drives are not supported at the same time.</li><li>• If 256 GB DIMM is used, rear 2.5-inch drives are not supported.</li></ul>

## Expansion slots

Expansion slots
<p>Depending on the model, your server supports up to three PCIe slots in the rear and up to two PCIe slots in the front.</p> <ul style="list-style-type: none"><li>• PCIe x16, low-profile</li><li>• PCIe x16/x16, low-profile + low-profile</li><li>• PCIe x16/x16, low profile + full-height</li><li>• PCIe x16, full-height</li></ul>

## Graphics processing unit (GPU)

### Graphics processing unit (GPU)

Your server supports the following GPUs:

- Half-length, single-wide:
  - NVIDIA® A2
  - NVIDIA® L4

#### Notes:

- For GPU supporting rules, see “Thermal rules” in *User Guide* or *Hardware Maintenance Guide*.
- To prevent potential thermal issues, change the **Misc** setting in the BIOS from **Option3** (default value) to **Option1** if the following two conditions are met:
  - The server is equipped with a GPU adapter.
  - The UEFI firmware version is ESE122T or later.

For the method of changing the **Misc** setting, see <https://support.lenovo.com/us/en/solutions/TT1832>.

## Integrated functions and I/O connectors

### Integrated functions and I/O connectors

- Lenovo XClarity Controller (XCC), which provides service processor control and monitoring functions, video controller, and remote keyboard, video, mouse, and remote drive capabilities.
  - The server supports Lenovo XClarity Controller 2 (XCC2). For additional information about Lenovo XClarity Controller 2 (XCC2), refer to <https://pubs.lenovo.com/lxcc-overview/>.
- One XCC system management port on the rear to connect to a systems-management network. This RJ-45 connector is dedicated to the Lenovo XClarity Controller functions and runs at 1 GB speed.
- A group of two or four Ethernet connectors on OCP module
- Up to four USB 3.2 Gen1 (5 Gbps) ports:
  - Three on the rear of the server
  - (Optional) One on the front of the server<sup>1</sup>
- One internal USB 3.2 Gen1 (5 Gbps) port
- (Optional) One USB 2.0 port on the front of the server<sup>1</sup>
- (Optional) External LCD diagnostics handset connector on the front of the server<sup>1</sup>
- Up to two VGA connectors
  - One on the rear of the server
  - (Optional) One on the front of the server<sup>1</sup>
- (Optional) One serial port connector on the rear of the server<sup>2</sup>

#### Notes:

1. Available when the front I/O module is installed in the server.
2. Available when the serial port cable is installed in the server.

## Network

### Network

- OCP module

**Note:** The OCP module is an optional part. It is default to be installed in the rear and optional in the front of the server.

## Rear button

### Rear button

- NMI button

## RAID adapter

### RAID adapter

- Onboard SATA ports with software RAID support (Intel VROC SATA RAID, supporting RAID levels 0, 1, 5, and 10) and JBOD
- Onboard NVMe ports with software RAID support (Intel VROC NVMe RAID) and JBOD
  - Intel VROC standard: requires an activation key and supports RAID levels 0, 1, and 10
  - Intel VROC Premium: requires an activation key and supports RAID levels 0, 1, 5, and 10
  - Intel VROC Boot (except 4510T, 4510, 4509Y, and 3508U): requires an activation key and supports RAID level 1 only<sup>Note</sup>
- Hardware RAID levels 0, 1, 10 and JBOD:
  - ThinkSystem RAID 540-8i PCIe Gen4 12Gb Adapter
  - ThinkSystem RAID 540-16i PCIe Gen4 12Gb Adapter
- Hardware RAID levels 0, 1, 5, 10 and JBOD:
  - ThinkSystem RAID 5350-8i PCIe 12Gb Adapter
  - ThinkSystem RAID 5350-8i PCIe 12Gb Internal Adapter
- Hardware RAID levels 0, 1, 10, 5, 50, 6, 60 and JBOD:
  - ThinkSystem RAID 9350-8i 2GB Flash PCIe 12Gb Adapter
  - ThinkSystem RAID 9350-8i 2GB Flash PCIe 12Gb Internal Adapter
  - ThinkSystem RAID 9350-16i 4GB Flash PCIe 12Gb Adapter
  - ThinkSystem RAID 9350-16i 4GB Flash PCIe 12Gb Internal Adapter
  - ThinkSystem RAID 940-8i 4GB Flash PCIe Gen4 12Gb Adapter
  - ThinkSystem RAID 940-8i 4GB Flash PCIe Gen4 12Gb Adapter (Tri-mode)
  - ThinkSystem RAID 940-16i 4GB Flash PCIe Gen4 12Gb Adapter
  - ThinkSystem RAID 940-16i 4GB Flash PCIe Gen4 12Gb Adapter (Tri-mode)
  - ThinkSystem RAID 940-16i 8GB Flash PCIe Gen4 12Gb Adapter
  - ThinkSystem RAID 940-16i 8GB Flash PCIe Gen4 12Gb Adapter (Tri-mode)
  - ThinkSystem RAID 940-16i 8GB Flash PCIe Gen4 12Gb Internal Adapter
- JBOD only:
  - ThinkSystem RAID 940-8e 4GB Flash PCIe Gen4 12Gb Adapter

#### Notes:

- Processors 4510T, 4510, 4509Y, and 3508U support Intel VROC standard and Intel VROC Premium.
- For more information about the RAID/HBA adapters, see [Lenovo ThinkSystem RAID Adapter and HBA Reference](#).

## Host bus adapter

Host bus adapter
<ul style="list-style-type: none"><li>• HBAs support JBOD:<ul style="list-style-type: none"><li>– ThinkSystem 4350-8i SAS/SATA 12Gb HBA</li><li>– ThinkSystem 4350-16i SAS/SATA 12Gb HBA</li><li>– ThinkSystem 440-8i SAS/SATA 12Gb HBA</li><li>– ThinkSystem 440-8e SAS/SATA 12Gb HBA</li><li>– ThinkSystem 440-16i SAS/SATA 12Gb HBA</li><li>– ThinkSystem 440-16e SAS/SATA 12Gb HBA</li><li>– ThinkSystem 440-16i SAS/SATA PCIe Gen4 12Gb Internal HBA</li></ul></li><li>• Fiber channel HBAs:<ul style="list-style-type: none"><li>– ThinkSystem QLogic 16Gb Enhanced Gen5 FC Single-port HBA</li><li>– ThinkSystem QLogic 16Gb Enhanced Gen5 FC Dual-port HBA</li><li>– ThinkSystem Emulex 16Gb Gen6 FC Single-port HBA</li><li>– ThinkSystem Emulex 16Gb Gen6 FC Dual-port HBA</li></ul></li></ul>

## System fan

System fan
<ul style="list-style-type: none"><li>• Supported fan types:<ul style="list-style-type: none"><li>– Standard fan 4056 (21000 RPM)</li><li>– Performance fan 4056 (28000 RPM)</li></ul></li><li>• Fan redundancy: N+1 redundancy, one redundant fan rotor<ul style="list-style-type: none"><li>– One processor: six hot-swap dual-rotor system fans (one redundant fan rotor)</li><li>– Two processors: eight hot-swap dual-rotor system fans (one redundant fan rotor)</li></ul></li></ul> <p><b>Note:</b> The redundant cooling by the fans in the server enables continued operation if one rotor of a fan fails.</p> <p>When the system is powered off but still plugged in to AC power, fans 1 and 2 may continue to spin at a much lower speed. This is the system design to provide proper cooling.</p>

## Electrical input

Electrical input				
One or two hot-swap power supply units for redundancy support:				
<i>Table 1. Electrical input for power supply units</i>				
Power supply	100–127 V ac	200–240 V ac	240 V dc	-48 V dc
750-watt 80 PLUS Platinum	√	√	√	
1100-watt 80 PLUS Platinum	√	√	√	
1800-watt 80 PLUS Platinum		√	√	
750-watt 80 PLUS Titanium		√	√	
1100-watt 80 PLUS Titanium		√	√	
1800-watt 80 PLUS Titanium		√	√	
1100-watt -48 V DC				√

**CAUTION:**

- **240 V dc input is supported in Chinese Mainland ONLY.**
- **Power supply with 240 V dc input cannot support hot plugging power cord function. Before removing the power supply with dc input, please turn off server or disconnect dc power sources at the breaker panel or by turning off the power source. Then, remove the power cord.**

## Minimal configuration for debugging

Minimal configuration for debugging
<ul style="list-style-type: none"><li>• One processor in processor socket 1</li><li>• One memory module in slot 7</li><li>• One power supply unit</li><li>• One HDD/SSD drive, one M.2 drive, or one 7mm drive (if OS is needed for debugging)</li><li>• Six system fans (with one processor)</li></ul>

## Operating systems

Operating systems
Supported and certified operating systems: <ul style="list-style-type: none"><li>• Microsoft Windows Server</li><li>• VMware ESXi</li><li>• Red Hat Enterprise Linux</li><li>• SUSE Linux Enterprise Server</li><li>• Canonical Ubuntu</li></ul> References: <ul style="list-style-type: none"><li>• Complete list of available operating systems: <a href="https://lenovopress.lenovo.com/osig">https://lenovopress.lenovo.com/osig</a>.</li><li>• OS deployment instructions: Follow the adopted combination to install DDR5 DIMMs (see “Install the operating system” in <i>User Guide</i>).</li></ul>

## Mechanical specifications

Summary of the mechanical specifications of the server. Depending on the model, some features might not be available, or some specifications might not apply.

Dimension
1U server <ul style="list-style-type: none"><li>• Height: 43.0 mm (1.69 inches)</li><li>• Width:<ul style="list-style-type: none"><li>– With rack latches: 482 mm (18.98 inches)</li><li>– Without rack latches: 434.4 mm (17.10 inches)</li></ul></li><li>• Depth: 787.6 mm (31.01 inches)</li></ul> <b>Note:</b> The depth is measured with rack latches and the handle of the power supply unit included.

Weight
<ul style="list-style-type: none"><li>• Net weight: up to 20.80 kg (45.86 lb)</li><li>• Gross weight: up to 28.41 kg (62.66 lb)</li></ul> <b>Note:</b> The gross weight includes the weights of the server, power cable, packaging, rail kit and cable management arm.

## Environmental specifications

Summary of the environmental specifications of the server. Depending on the model, some features might not be available, or some specifications might not apply.

- “Acoustical noise emissions” on page 13
- “Ambient temperature management” on page 14
- “Environment” on page 15
- “Water requirements” on page 17

## Acoustical noise emissions

Acoustical noise emissions						
The server has the following acoustic noise emissions declaration:						
<i>Table 2. Acoustic noise emissions declaration</i>						
Scenario	Used configuration	Sound power level (L <sub>WA,d</sub> )		Sound pressure level (L <sub>pAm</sub> ):		
		Idling	Operating	Idling	Operating	
Minimal	Two 150 W processors Thirty two 64 GB RDIMMs Eight SAS hard disk drives RAID 440-16i CFF adapter Intel X710-T2L 10GBASE-T 2-port OCP adapter Two 750-watt power supply units	5.8 Bel	6.4 Bel	45 dBA	50 dBA	
Typical	Two 205 W processors Thirty two 64 GB RDIMMs Ten SAS hard disk drives RAID 940-16i SFF adapter Intel X710-T2L 10GBASE-T 2-port OCP adapter Two 1100-watt power supply units	6.7 Bel	7.7 Bel	54 dBA	61 dBA	
Storage rich	Two 165 W processors Thirty two 64 GB RDIMMs 12 SAS hard disk drives RAID 940-16i SFF adapter Intel X710-T2L 10GBASE-T 2-port OCP adapter Two 750-watt power supply units	7.5 Bel	7.6 Bel	60 dBA	61 dBA	
GPU rich	Two 205 W processors Thirty two 64 GB RDIMMs Ten SAS hard disk drives RAID 940-16i SFF adapter Intel X710-T2L 10GBASE-T 2-port OCP adapter Two 1100-watt power supply units	6.7 Bel	8.3 Bel	53 dBA	68 dBA	
<b>Notes:</b>						

### Acoustical noise emissions

- These sound power levels are measured in controlled acoustical environments according to procedures specified by ISO 7779 and are reported in accordance with ISO 9296.
- The declared sound levels may change depending on configuration/conditions, for example, with high-power NICs, high-power processors and GPUs, such as ThinkSystem Mellanox ConnectX-6 HDR/200GbE QSFP56 1-port/2-port PCIe Adapter, ThinkSystem Broadcom 57454 10GBASE-T 4-port OCP Ethernet Adapter.
- Government regulations (such as those prescribed by OSHA or European Community Directives) may govern noise level exposure in the workplace and may apply to you and your server installation. The actual sound pressure levels in your installation depend upon a variety of factors, including the number of racks in the installation; the size, materials, and configuration of the room; the noise levels from other equipment; the room ambient temperature, and employee's location in relation to the equipment. Further, compliance with such government regulations depends on a variety of additional factors, including the duration of employees' exposure and whether employees wear hearing protection. Lenovo recommends that you consult with qualified experts in this field to determine whether you are in compliance with the applicable regulations.

## Ambient temperature management

### Ambient temperature management

The server is supported in the following environment:

- Air temperature:
  - Operating:
    - ASHRAE class H1: 5–25°C (41–77°F); when the altitude exceeds 900 m (2953 ft), the maximum ambient temperature value decreases by 1°C (1.8°F) with every 500 m (1640 ft) of altitude increase.
    - ASHRAE class A2: 10–35°C (50–95°F); when the altitude exceeds 900 m (2953 ft), the maximum ambient temperature value decreases by 1°C (1.8°F) with every 300 m (984 ft) of altitude increase.
    - ASHRAE class A3: 5–40°C (41–104°F); when the altitude exceeds 900 m (2953 ft), the maximum ambient temperature value decreases by 1°C (1.8°F) with every 175 m (574 ft) of altitude increase.
    - ASHRAE class A4: 5–45°C (41–113°F); when the altitude exceeds 900 m (2953 ft), the maximum ambient temperature value decreases by 1°C (1.8°F) with every 125 m (410 ft) of altitude increase.
  - Server off: 5–45°C (41–113°F)
  - Shipping or storage: -40–60°C (-40–140°F)
- Maximum altitude: 3050 m (10 000 ft)
- Relative humidity (non-condensing):
  - Operating:
    - ASHRAE Class H1: 8%–80%, maximum dew point: 17°C (62.6°F)
    - ASHRAE Class A2: 8%–80%, maximum dew point: 21°C (70°F)
    - ASHRAE Class A3: 8%–85%, maximum dew point: 24°C (75°F)
    - ASHRAE Class A4: 8%–90%, maximum dew point: 24°C (75°F)
  - Shipment or storage: 8%–90%
- Particulate contamination

**Attention:** Airborne particulates and reactive gases acting alone or in combination with other environmental factors such as humidity or temperature might pose a risk to the server. For information about the limits for particulates and gases, see [“Particulate contamination” on page 17](#).

## Environment

Environment
<p>ThinkSystem SR630 V3 complies with ASHRAE Class A2 specifications. System performance may be affected when operating temperature is outside of AHSARE A2 specification.</p> <ul style="list-style-type: none"><li>• Air temperature:<ul style="list-style-type: none"><li>– Operating<ul style="list-style-type: none"><li>– ASHARE Class A2: 10°C to 35°C (50°F to 95°F); the maximum ambient temperature decreases by 1°C for every 300 m (984 ft) increase in altitude above 900 m (2,953 ft).</li></ul></li><li>– Server off: 5°C to 45°C (41°F to 113°F)</li><li>– Shipment/storage: -40°C to 60°C (-40°F to 140°F)</li></ul></li><li>• Maximum altitude: 3,050 m (10,000 ft)</li><li>• Relative Humidity (non-condensing):<ul style="list-style-type: none"><li>– Operating<ul style="list-style-type: none"><li>– ASHRAE Class A2: 8% to 80%; maximum dew point: 21°C (70°F)</li></ul></li><li>– Shipment/storage: 8% to 90%</li></ul></li><li>• Particulate contamination</li></ul> <p><b>Attention:</b> Airborne particulates and reactive gases acting alone or in combination with other environmental factors such as humidity or temperature might pose a risk to the server. For information about the limits for particulates and gases, see <a href="#">“Particulate contamination” on page 17</a>.</p> <p><b>Note:</b> The server is designed for standard data center environment and recommended to be placed in industrial data centers.</p> <p>When the ambient temperature is greater than the supported max temperature (ASHARE A4 45°C), the server will shut down. The server will not power on again until the ambient temperature falls within the supported temperature range. Depending on hardware configurations, the server complies with ASHRAE Class H1, A2, A3, or A4 specifications with certain thermal restrictions. System performance may be impacted when operating temperature is out of permitted conditions.</p> <p>The restrictions to ASHRAE support are as follows (cooling by air or Liquid to Air Module (L2AM)) :</p> <ul style="list-style-type: none"><li>• The ambient temperature must be no more than 25°C if your server meets the following conditions when installing:<ul style="list-style-type: none"><li>– <math>300\text{ W} \leq \text{TDP} \leq 350\text{ W}</math></li><li>– L2AM</li><li>– ThinkSystem 128GB TruDDR5 4800MHz (4Rx4) 3DS RDIMM v1, ThinkSystem 128GB TruDDR5 4800MHz (4Rx4) 3DS RDIMM v2 or ThinkSystem 128GB TruDDR5 5600MHz (4Rx4) 3DS RDIMM with L2AM</li><li>– ThinkSystem 256GB TruDDR5 4800MHz (8Rx4) 3DS RDIMM v1 and standard or performance heat sinks, and 4 x 2.5" backplane or no backplane</li></ul></li><li>• The ambient temperature must be no more than 30°C if your server meets any of the following conditions when installing:<ul style="list-style-type: none"><li>– <math>205\text{ W} &lt; \text{TDP} \leq 350\text{ W}</math></li><li>– Any rear 2.5-inch NVMe drive</li><li>– A2/L4 GPU on the rear</li><li>– Any ConnectX-6/ConnectX-7 adapters with the AOC transceiver</li><li>– Parts with AOC transceivers and the rate is greater than 25 GB</li><li>– <math>205\text{ W} &lt; \text{TDP} &lt; 300\text{ W}</math> with the L2AM</li><li>– ThinkSystem 128GB TruDDR5 4800MHz (4Rx4) 3DS RDIMM v1, ThinkSystem 256GB TruDDR5 4800MHz (8Rx4) 3DS RDIMM v2 with standard or performance heat sinks</li></ul></li><li>• The ambient temperature must be no more than 35°C if your server meets any of the following conditions when installing:<ul style="list-style-type: none"><li>– <math>165\text{ W} &lt; \text{TDP} \leq 205\text{ W}</math></li><li>– ThinkSystem 128GB TruDDR5 4800MHz (4Rx4) 3DS RDIMM v2, ThinkSystem 128GB TruDDR5 5600MHz (4Rx4) 3DS RDIMM, or ThinkSystem 96GB TruDDR5 5600MHz (2Rx4) 10x4 RDIMM</li></ul></li></ul>

## Environment

- Any front NVMe drive or rear NVMe AIC SSD
- Any 7mm boot drive
- Any M.2 NVMe drive
- Any rear 2.5-inch SAS/SATA drive
- ThinkSystem Broadcom 57454 10GBASE-T 4-port OCP/ Broadcom 57416 10GBASE-T 2-port OCP
- PCIe network interface cards (NICs) and OCP modules at a rate greater than or equal to 100 GB
- Parts with AOC transceivers and at the rate of 25 GB
- TDP  $\leq$  205 W with the L2AM
- A2/L4 GPU on the front
- The ambient temperature must be no more than 45°C if the processor TDP is equal to or smaller than 185 W.

The restrictions to ASHRAE support are as follows (cooling by Direct Water Cooling Module (DWCM)) :

- The ambient temperature must be no more than 25°C if your server meets the following conditions when installing:
  - TDP  $\leq$  350
  - DWCM
  - ThinkSystem 256GB TruDDR5 4800MHz (8Rx4) 3DS RDIMM v1 but except for 4 x 2.5" backplane or no backplane
- The ambient temperature must be no more than 30°C if your server meets the following conditions when installing:
  - TDP  $\leq$  350
  - DWCM
  - Standard fans
  - Any ConnectX-6/ConnectX-7 adapters with the AOC transceiver
- The ambient temperature must be no more than 35°C if your server meets the following conditions when installing:
  - TDP  $\leq$  350
  - DWCM
  - A2/L4 GPU and performance fans
  - Any ConnectX-6/ConnectX-7 adapters with the AOC transceiver
  - ThinkSystem 128GB TruDDR5 4800MHz (4Rx4) 3DS RDIMM v1 or ThinkSystem 256GB TruDDR5 4800MHz (8Rx4) 3DS RDIMM v2 with performance fans
  - ThinkSystem 128GB TruDDR5 4800MHz (4Rx4) 3DS RDIMM v2 or ThinkSystem 128GB TruDDR5 5600MHz (4Rx4) 3DS RDIMM with DWCM
  - ThinkSystem 256GB TruDDR5 4800MHz (8Rx4) 3DS RDIMM v1 and 4 x 2.5" backplane or no backplane

**Note:** For more thermal information about 128/256 GB RDIMMs, see "Thermal rules for 128/256 GB RDIMMs" in *User Guide* or *Hardware Maintenance Guide*.

## Water requirements

Water requirements	
ThinkSystem SR630 V3 is supported in the following environment:	
<ul style="list-style-type: none"><li>• Maximum pressure: 3 bars</li><li>• Water inlet temperature and flow rates:</li></ul>	
Water inlet temperature	Water flow rate
50°C (122°F)	1.5 liters per minute (lpm) per server
45°C (113°F)	1 liter per minute (lpm) per server
40°C (104°F) or lower	0.5 liters per minute (lpm) per server

**Note:** The water required to initially fill the system side cooling loop must be reasonably clean, bacteria-free water (<100 CFU/ml) such as de-mineralized water, reverse osmosis water, de-ionized water, or distilled water. The water must be filtered with an in-line 50 micron filter (approximately 288 mesh). The water must be treated with anti-biological and anti-corrosion measures.

## Particulate contamination

**Attention:** Airborne particulates (including metal flakes or particles) and reactive gases acting alone or in combination with other environmental factors such as humidity or temperature might pose a risk to the device that is described in this document.

Risks that are posed by the presence of excessive particulate levels or concentrations of harmful gases include damage that might cause the device to malfunction or cease functioning altogether. This specification sets forth limits for particulates and gases that are intended to avoid such damage. The limits must not be viewed or used as definitive limits, because numerous factors, such as temperature or moisture in the air, can influence the effect of particulates or environmental corrosives and gaseous contaminant transfer. In the absence of specific limits that are set forth in this document, you must implement practices that maintain particulate and gas levels that are consistent with the protection of human health and safety. If Lenovo determines that the levels of particulates or gases in your environment have caused damage to the device, Lenovo may condition provision of repair or replacement of devices or parts on implementation of appropriate remedial measures to mitigate such environmental contamination. Implementation of such remedial measures is a customer responsibility.

Table 3. Limits for particulates and gases

Contaminant	Limits
Reactive gases	<p>Severity level G1 as per ANSI/ISA 71.04-1985<sup>1</sup>:</p> <ul style="list-style-type: none"> <li>• The copper reactivity level shall be less than 200 Angstroms per month (<math>\text{\AA}/\text{month} \approx 0.0035 \mu\text{g}/\text{cm}^2\text{-hour}</math> weight gain).<sup>2</sup></li> <li>• The silver reactivity level shall be less than 200 Angstroms per month (<math>\text{\AA}/\text{month} \approx 0.0035 \mu\text{g}/\text{cm}^2\text{-hour}</math> weight gain).<sup>3</sup></li> <li>• The reactive monitoring of gaseous corrosivity must be conducted approximately 5 cm (2 in.) in front of the rack on the air inlet side at one-quarter and three-quarter frame height off the floor or where the air velocity is much higher.</li> </ul>
Airborne particulates	<p>Data centers must meet the cleanliness level of ISO 14644-1 class 8.</p> <p>For data centers without airside economizer, the ISO 14644-1 class 8 cleanliness might be met by choosing one of the following filtration methods:</p> <ul style="list-style-type: none"> <li>• The room air might be continuously filtered with MERV 8 filters.</li> <li>• Air entering a data center might be filtered with MERV 11 or preferably MERV 13 filters.</li> </ul> <p>For data centers with airside economizers, the choice of filters to achieve ISO class 8 cleanliness depends on the specific conditions present at that data center.</p> <ul style="list-style-type: none"> <li>• The deliquescent relative humidity of the particulate contamination should be more than 60% RH.<sup>4</sup></li> <li>• Data centers must be free of zinc whiskers.<sup>5</sup></li> </ul>

<sup>1</sup> ANSI/ISA-71.04-1985. *Environmental conditions for process measurement and control systems: Airborne contaminants*. Instrument Society of America, Research Triangle Park, North Carolina, U.S.A.

<sup>2</sup> The derivation of the equivalence between the rate of copper corrosion growth in the thickness of the corrosion product in  $\text{\AA}/\text{month}$  and the rate of weight gain assumes that  $\text{Cu}_2\text{S}$  and  $\text{Cu}_2\text{O}$  grow in equal proportions.

<sup>3</sup> The derivation of the equivalence between the rate of silver corrosion growth in the thickness of the corrosion product in  $\text{\AA}/\text{month}$  and the rate of weight gain assumes that  $\text{Ag}_2\text{S}$  is the only corrosion product.

<sup>4</sup> The deliquescent relative humidity of particulate contamination is the relative humidity at which the dust absorbs enough water to become wet and promote ionic conduction.

<sup>5</sup> Surface debris is randomly collected from 10 areas of the data center on a 1.5 cm diameter disk of sticky electrically conductive tape on a metal stub. If examination of the sticky tape in a scanning electron microscope reveals no zinc whiskers, the data center is considered free of zinc whiskers.

## Management options

The XClarity portfolio and other system management options described in this section are available to help you manage the servers more conveniently and efficiently.

## Overview

Options	Description
Lenovo XClarity Controller	<p>Baseboard management controller (BMC)</p> <p>Consolidates the service processor functionality, Super I/O, video controller, and remote presence capabilities into a single chip on the server system board (system board assembly).</p> <p><b>Interface</b></p> <ul style="list-style-type: none"> <li>• CLI application</li> <li>• Web GUI interface</li> <li>• Mobile application</li> <li>• Redfish API</li> </ul> <p><b>Usage and downloads</b></p> <p><a href="https://pubs.lenovo.com/lxcc-overview/">https://pubs.lenovo.com/lxcc-overview/</a></p>
Lenovo XCC Logger Utility	<p>Application that reports the XCC events to local OS system log.</p> <p><b>Interface</b></p> <ul style="list-style-type: none"> <li>• CLI application</li> </ul> <p><b>Usage and downloads</b></p> <ul style="list-style-type: none"> <li>• <a href="https://pubs.lenovo.com/lxcc-logger-linux/">https://pubs.lenovo.com/lxcc-logger-linux/</a></li> <li>• <a href="https://pubs.lenovo.com/lxcc-logger-windows/">https://pubs.lenovo.com/lxcc-logger-windows/</a></li> </ul>
Lenovo XClarity Administrator	<p>Centralized interface for multi-server management.</p> <p><b>Interface</b></p> <ul style="list-style-type: none"> <li>• Web GUI interface</li> <li>• Mobile application</li> <li>• REST API</li> </ul> <p><b>Usage and downloads</b></p> <p><a href="https://pubs.lenovo.com/lxca/">https://pubs.lenovo.com/lxca/</a></p>
Lenovo XClarity Essentials toolset	<p>Portable and light toolset for server configuration, data collection, and firmware updates. Suitable both for single-server or multi-server management contexts.</p> <p><b>Interface</b></p> <ul style="list-style-type: none"> <li>• <b>OneCLI:</b> CLI application</li> <li>• <b>Bootable Media Creator:</b> CLI application, GUI application</li> <li>• <b>UpdateXpress:</b> GUI application</li> </ul> <p><b>Usage and downloads</b></p> <p><a href="https://pubs.lenovo.com/lxce-overview/">https://pubs.lenovo.com/lxce-overview/</a></p>

Options	Description
Lenovo XClarity Provisioning Manager	<p>UEFI-based embedded GUI tool on a single server that can simplify management tasks.</p> <p><b>Interface</b></p> <ul style="list-style-type: none"> <li>• Web interface (BMC remote access)</li> <li>• GUI application</li> </ul> <p><b>Usage and downloads</b></p> <p><a href="https://pubs.lenovo.com/lxpm-overview/">https://pubs.lenovo.com/lxpm-overview/</a></p> <p><b>Important:</b> Lenovo XClarity Provisioning Manager (LXPM) supported version varies by product. All versions of Lenovo XClarity Provisioning Manager are referred to as Lenovo XClarity Provisioning Manager and LXPM in this document, unless specified otherwise. To see the LXPM version supported by your server, go to <a href="https://pubs.lenovo.com/lxpm-overview/">https://pubs.lenovo.com/lxpm-overview/</a>.</p>
Lenovo XClarity Integrator	<p>Series of applications that integrate the management and monitoring functionalities of the Lenovo physical servers with the software used in a certain deployment infrastructure, such as VMware vCenter, Microsoft Admin Center, or Microsoft System Center while delivering additional workload resiliency.</p> <p><b>Interface</b></p> <ul style="list-style-type: none"> <li>• GUI application</li> </ul> <p><b>Usage and downloads</b></p> <p><a href="https://pubs.lenovo.com/lxci-overview/">https://pubs.lenovo.com/lxci-overview/</a></p>
Lenovo XClarity Energy Manager	<p>Application that can manage and monitor server power and temperature.</p> <p><b>Interface</b></p> <ul style="list-style-type: none"> <li>• Web GUI Interface</li> </ul> <p><b>Usage and downloads</b></p> <p><a href="https://datacentersupport.lenovo.com/solutions/Invo-lxem">https://datacentersupport.lenovo.com/solutions/Invo-lxem</a></p>
Lenovo Capacity Planner	<p>Application that supports power consumption planning for a server or rack.</p> <p><b>Interface</b></p> <ul style="list-style-type: none"> <li>• Web GUI Interface</li> </ul> <p><b>Usage and downloads</b></p> <p><a href="https://datacentersupport.lenovo.com/solutions/Invo-lcp">https://datacentersupport.lenovo.com/solutions/Invo-lcp</a></p>

## Functions

Options		Functions							
		Multi-system mgmt	OS deployment	System configuration	Firmware updates <sup>1</sup>	Event/alert monitoring	Inventory/logs	Power mgmt	Power planning
Lenovo XClarity Controller				√	√ <sup>2</sup>	√	√ <sup>4</sup>		
Lenovo XCC Logger Utility						√			
Lenovo XClarity Administrator		√	√	√	√ <sup>2</sup>	√	√ <sup>4</sup>		
Lenovo XClarity Essentials toolset	OneCLI	√		√	√ <sup>2</sup>	√	√		
	Bootable Media Creator			√	√ <sup>2</sup>		√ <sup>4</sup>		
	UpdateXpress			√	√ <sup>2</sup>				
Lenovo XClarity Provisioning Manager			√	√	√ <sup>3</sup>		√ <sup>5</sup>		
Lenovo XClarity Integrator		√	√ <sup>6</sup>	√	√	√	√	√ <sup>7</sup>	
Lenovo XClarity Energy Manager		√				√		√	
Lenovo Capacity Planner									√ <sup>8</sup>

### Notes:

1. Most options can be updated through the Lenovo tools. Some options, such as GPU firmware or Omni-Path firmware require the use of supplier tools.
2. The server UEFI settings for option ROM must be set to **Auto** or **UEFI** to update firmware using Lenovo XClarity Administrator, Lenovo XClarity Essentials, or Lenovo XClarity Controller.
3. Firmware updates are limited to Lenovo XClarity Provisioning Manager, Lenovo XClarity Controller, and UEFI updates only. Firmware updates for optional devices, such as adapters, are not supported.
4. The server UEFI settings for option ROM must be set to **Auto** or **UEFI** for detailed adapter card information, such as model name and firmware levels, to be displayed in Lenovo XClarity Administrator, Lenovo XClarity Controller, or Lenovo XClarity Essentials.
5. Limited inventory.
6. The Lenovo XClarity Integrator deployment check for System Center Configuration Manager (SCCM) supports Windows operating system deployment.
7. Power management function is supported only by Lenovo XClarity Integrator for VMware vCenter.
8. It is highly recommended that you check the power summary data for your server using Lenovo Capacity Planner before purchasing any new parts.



## Chapter 2. Server components

This section includes information about the front view, rear view, and top view of the server. Front I/O modules, the system board assembly and LEDs are also illustrated in details.

### Front view

The front view of the server varies by model. Depending on the model, your server might look slightly different from the illustrations in this topic.

Refer to the following front view for different server models:

- “Server models with four 2.5-inch front drive bays” on page 23
- “Server models with four 2.5-inch front drive bays and a front riser assembly” on page 24
- “Server models with eight 2.5-inch front drive bays” on page 25
- “Server models with ten 2.5-inch front drive bays” on page 25
- “Server models with 16 EDSFF front drives” on page 26
- “Server model with 16 EDSFF drives and an M.2 cage” on page 27
- “Server models with four 3.5-inch front drive bays” on page 27
- “Server models with 2.5-inch front drive bays (backplane-less)” on page 28
- “Server models with 3.5-inch front drive bays (backplane-less)” on page 28
- “Server models with eight 2.5-inch front drive bays (with LCD diagnostics panel)” on page 29
- “Server models with 16 EDSFF front drives (with LCD diagnostics panel)” on page 30

#### Server model with four 2.5-inch drive bays

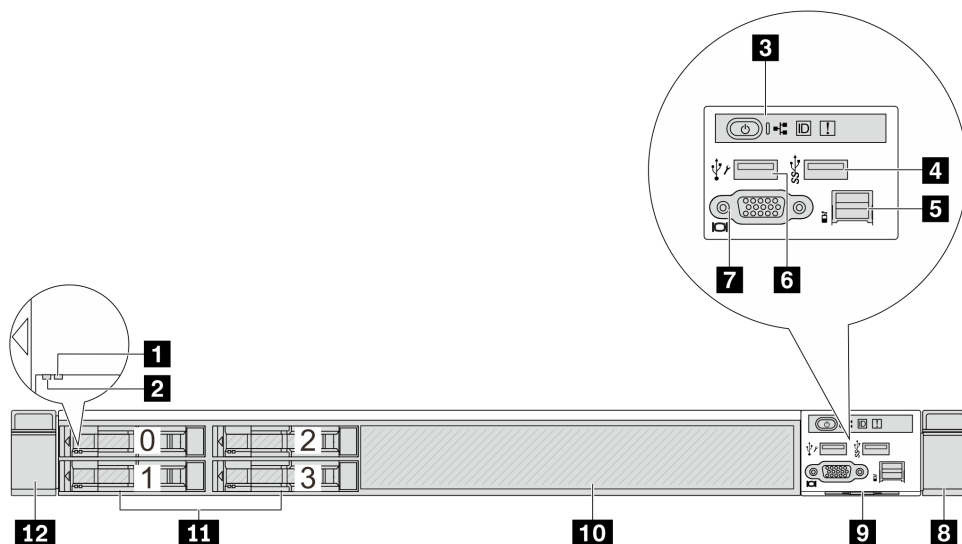

Table 4. Components on the front of the server

Callout	Callout
<b>1</b> Drive status LED	<b>2</b> Drive activity LED
<b>3</b> Diagnostics panel	<b>4</b> USB 3.2 Gen 1 (5Gbps) connector

Table 4. Components on the front of the server (continued)

Callout	Callout
<b>5</b> External LCD connector	<b>6</b> XClarity Controller USB connector
<b>7</b> VGA connector (optional)	<b>8</b> Rack latch (right)
<b>9</b> Pull-out information tab	<b>10</b> Drive filler (1)
<b>11</b> Drive bays (4)	<b>12</b> Rack latch (left)

**Note:** For more information about each component, see [“Front components overview” on page 30](#).

**Server model with four 2.5-inch drive bays and a front riser assembly**

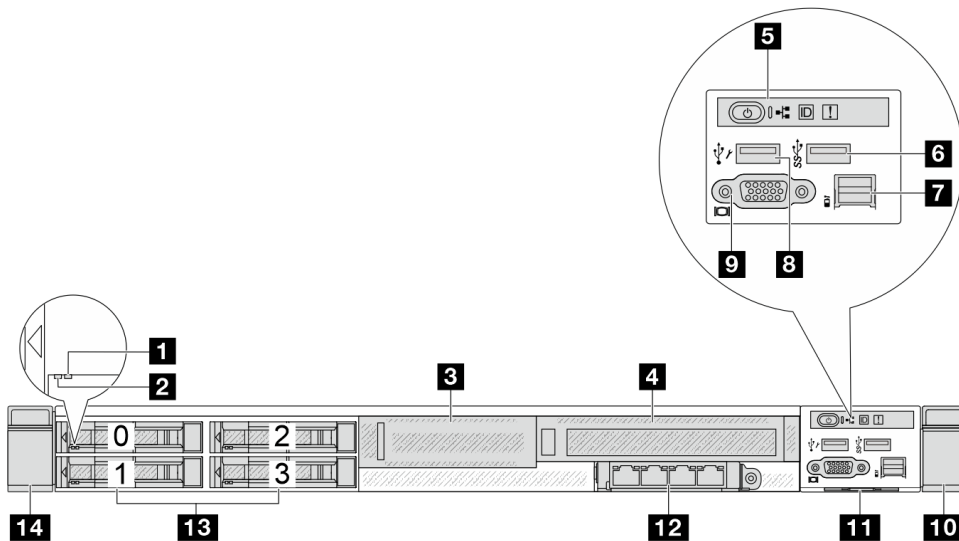

Table 5. Components on the front of the server

Callout	Callout
<b>1</b> Drive status LED	<b>2</b> Drive activity LED
<b>3</b> Front low-profile riser assembly	<b>4</b> Front full-height riser assembly
<b>5</b> Diagnostics panel	<b>6</b> USB 3.2 Gen 1 (5Gbps) connector
<b>7</b> External LCD connector	<b>8</b> XClarity Controller USB connector
<b>9</b> VGA connector (optional)	<b>10</b> Rack latch (right)
<b>11</b> Pull-out information tab	<b>12</b> Front OCP module
<b>13</b> Drive bays (4)	<b>14</b> Rack latch (left)

**Note:** For more information about each component, see [“Front components overview” on page 30](#).

### Server model with eight 2.5-inch drive bays

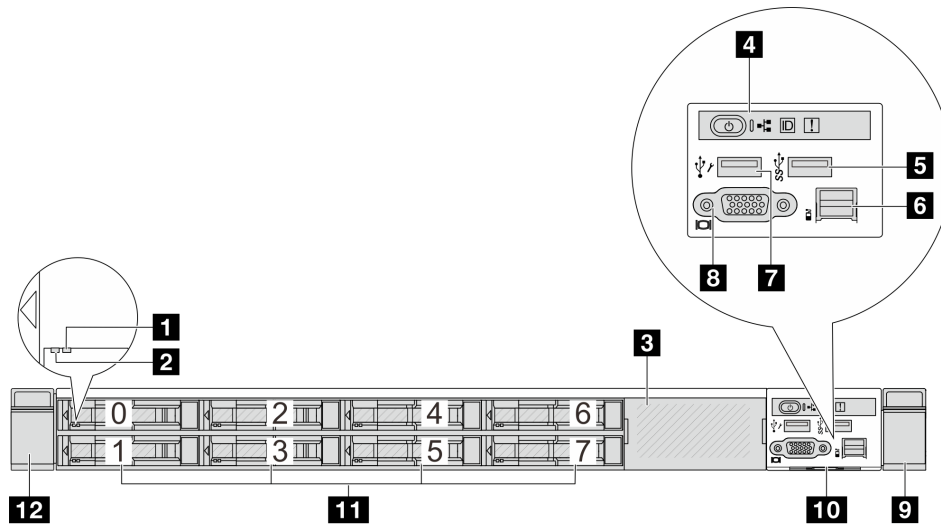

Table 6. Components on the front of the server

Callout	Callout
<b>1</b> Drive status LED	<b>2</b> Drive activity LED
<b>3</b> Drive filler (1)	<b>4</b> Diagnostics panel
<b>5</b> USB 3.2 Gen 1 (5Gbps) connector	<b>6</b> External LCD connector
<b>7</b> XClarity Controller USB connector	<b>8</b> VGA connector (optional)
<b>9</b> Rack latch (right)	<b>10</b> Pull-out information tab
<b>11</b> Drive bays (8)	<b>12</b> Rack latch (left)

**Note:** For more information about each component, see [“Front components overview”](#) on page 30.

### Server model with ten 2.5-inch drive bays

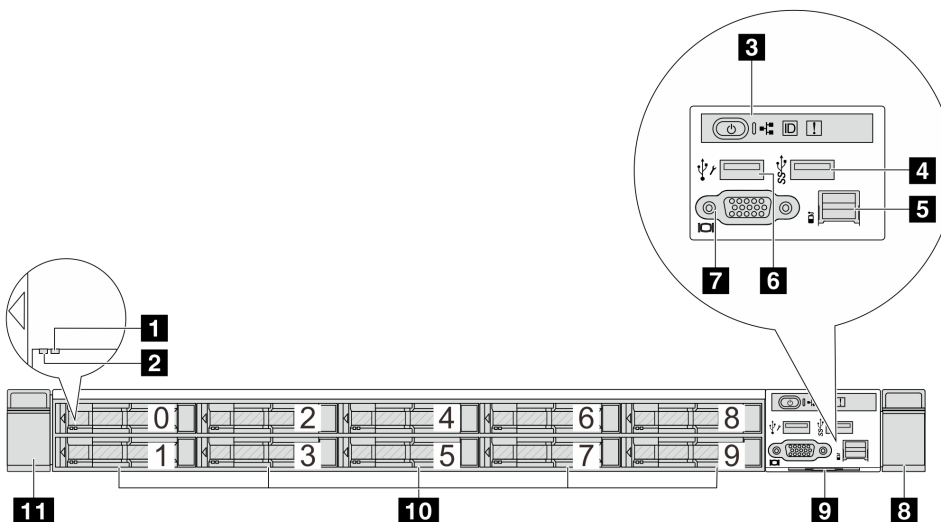

Table 7. Components on the front of the server

Callout	Callout
<b>1</b> Drive status LED	<b>2</b> Drive activity LED
<b>3</b> Diagnostics panel	<b>4</b> USB 3.2 Gen 1 (5Gbps) connector
<b>5</b> External LCD connector	<b>6</b> XClarity Controller USB connector
<b>7</b> VGA connector (optional)	<b>8</b> Rack latch (right)
<b>9</b> Pull-out information tab	<b>10</b> Drive bays (10)
<b>11</b> Rack latch (left)	

**Note:** For more information about each component, see [“Front components overview” on page 30](#).

**Server model with 16 EDSFF drives**

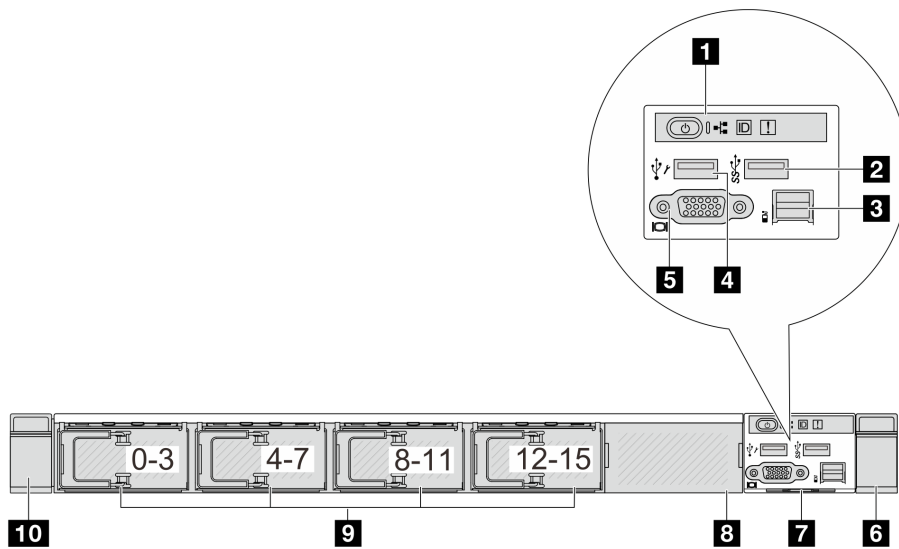

Table 8. Components on the front of the server

Callout	Callout
<b>1</b> Diagnostics panel	<b>2</b> USB 3.2 Gen 1 (5Gbps) connector
<b>3</b> External LCD connector	<b>4</b> XClarity Controller USB connector
<b>5</b> VGA connector (optional)	<b>6</b> Rack latch (right)
<b>7</b> Pull-out information tab	<b>8</b> Drive filler (1)
<b>9</b> Drive bays (16)	<b>10</b> Rack latch (left)

**Note:** For more information about each component, see [“Front components overview” on page 30](#).

### Server model with 16 EDSFF drives and an M.2 cage

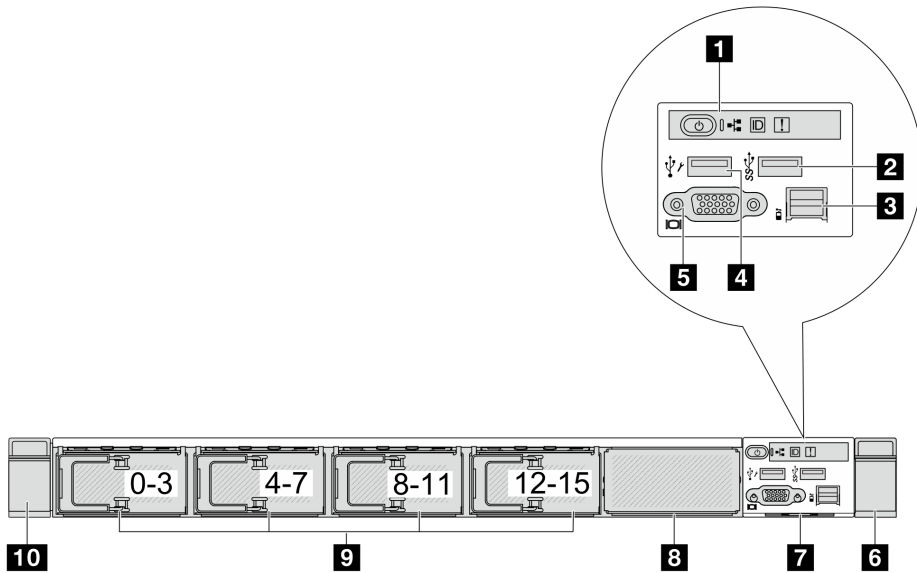

Table 9. Components on the front of the server

Callout	Callout
<b>1</b> Diagnostics panel	<b>2</b> USB 3.2 Gen 1 (5Gbps) connector
<b>3</b> External LCD connector	<b>4</b> XClarity Controller USB connector
<b>5</b> VGA connector (optional)	<b>6</b> Rack latch (right)
<b>7</b> Pull-out information tab	<b>8</b> M.2 cage
<b>9</b> Drive bays (16)	<b>10</b> Rack latch (left)

**Note:** For more information about each component, see [“Front components overview”](#) on page 30.

### Server model with four 3.5-inch drive bays

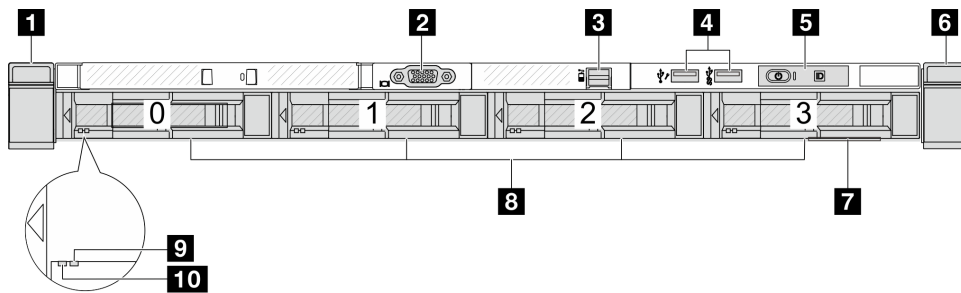

Table 10. Components on the front of the server

Callout	Callout
<b>1</b> Rack latch (left)	<b>2</b> VGA connector (optional)
<b>3</b> External LCD connector	<b>4</b> XClarity Controller USB connector and USB 3.2 Gen 1 (5Gbps) connector
<b>5</b> Diagnostics panel	<b>6</b> Rack latch (right)

Table 10. Components on the front of the server (continued)

Callout	Callout
<b>7</b> Pull-out information tab	<b>8</b> Drive bays (4)
<b>9</b> Drive status LED	<b>10</b> Drive activity LED

**Note:** For more information about each component, see [“Front components overview”](#) on page 30.

**Server model with 2.5-inch drive bays (backplane-less)**

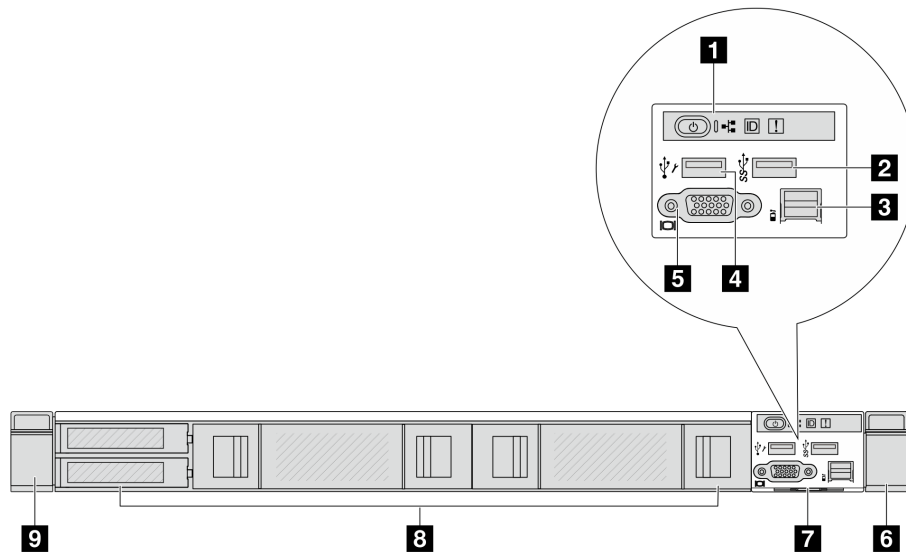

Table 11. Components on the front of the server

Callout	Callout
<b>1</b> Diagnostics panel	<b>2</b> USB 3.2 Gen 1 (5Gbps) connector
<b>3</b> External LCD connector (reserved)	<b>4</b> XClarity Controller USB connector
<b>5</b> VGA connector (optional)	<b>6</b> Rack latch (right)
<b>7</b> Pull-out information tab	<b>8</b> Drive fillers (4)
<b>9</b> Rack latch (left)	

**Note:** For more information about each component, see [“Front components overview”](#) on page 30.

**Server model with 3.5-inch drive bays (backplane-less)**

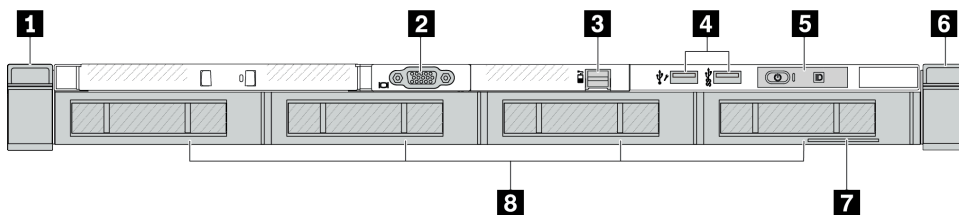

Table 12. Components on the front of the server

Callout	Callout
<b>1</b> Rack latch (left)	<b>2</b> VGA connector (optional)
<b>3</b> External LCD connector	<b>4</b> XClarity Controller USB connector and USB 3.2 Gen 1 (5Gbps) connector
<b>5</b> Diagnostics panel	<b>6</b> Rack latch (right)
<b>7</b> Pull-out information tab	<b>8</b> Drive fillers (4)

**Note:** For more information about each component, see [“Front components overview” on page 30](#).

**Server model with eight 2.5-inch drive bays (with LCD diagnostics panel assembly)**

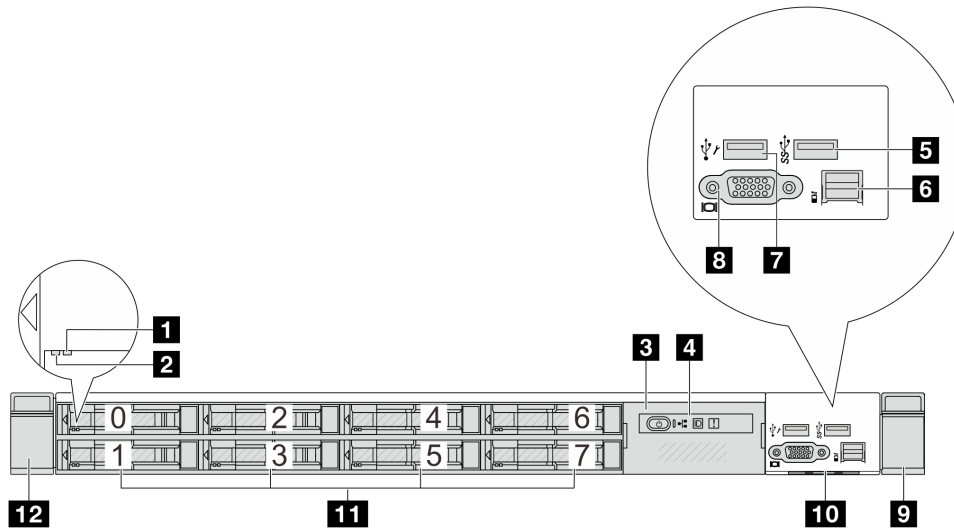

Table 13. Components on the front of the server

Callout	Callout
<b>1</b> Drive status LED	<b>2</b> Drive activity LED
<b>3</b> LCD diagnostics panel assembly	<b>4</b> LCD diagnostics panel
<b>5</b> USB 3.2 Gen 1 (5Gbps) connector	<b>6</b> External LCD connector
<b>7</b> XClarity Controller USB connector	<b>8</b> VGA connector (optional)
<b>9</b> Rack latch (right)	<b>10</b> Pull-out information tab
<b>11</b> Drive bays (8)	<b>12</b> Rack latch (left)

**Note:** For more information about each component, see [“Front components overview” on page 30](#).

## Server model with 16 EDSFF drives (with LCD diagnostics panel assembly)

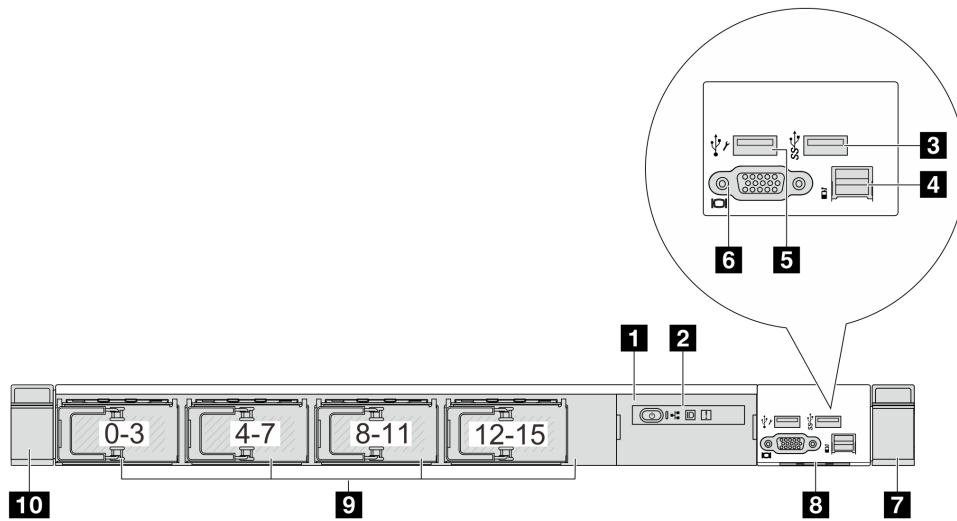

Table 14. Components on the front of the server

Callout	Callout
<b>1</b> LCD diagnostics panel assembly	<b>2</b> LCD diagnostics panel
<b>3</b> USB 3.2 Gen 1 (5Gbps) connector	<b>4</b> External LCD connector
<b>5</b> XClarity Controller USB connector	<b>6</b> VGA connector (optional)
<b>7</b> Rack latch (right)	<b>8</b> Pull-out information tab
<b>9</b> Drive bays (16)	<b>10</b> Rack latch (left)

**Note:** For more information about each component, see [“Front components overview”](#) on page 30.

### Front components overview

#### Integrated diagnostics panel

The diagnostics panel is integrated in front I/O assembly on some models. For information about the controls and status LEDs on the diagnostics panel, see “Integrated diagnostics panel” in *User Guide* or *Hardware Maintenance Guide*.

#### External diagnostics port

The connector is for connecting an external diagnostics handset. For more about its functions, see “External diagnostics handset” in *User Guide* or *Hardware Maintenance Guide*.

#### Front operator panel

The assembly comes with an integrated LCD diagnostics panel that can be used to quickly obtain system status, firmware levels, network information, and health information about the system. For more about the panel functions, see “Front operator panel” in *User Guide* or *Hardware Maintenance Guide*.

#### Hot-swap drives and drive bays

The drive bays on the front and rear of your server are designed for hot-swap drives. The number of the installed drives in your server varies by model. When you install drives, follow the order of the drive bay numbers.

The EMI integrity and cooling of the server are protected by having all drive bays occupied. Vacant drive bays must be occupied by drive fillers.

### **Pull-out information tab**

The Lenovo XClarity Controller network access label is attached on the pull-out information tab. The default Lenovo XClarity Controller hostname and the IPv6 Link Local Address (LLA) are provided on the tab.

### **Rack latches**

If your server is installed in a rack, you can use the rack latches to help you slide the server out of the rack. You also can use the rack latches and screws to secure the server in the rack so that the server cannot slide out, especially in vibration-prone areas. For more information, refer to the *Rack Installation Guide* that comes with your rail kit.

### **USB 3.2 Gen 1 (5Gbps) connectors**

The USB 3.2 Gen 1 (5Gbps) connectors can be used to attach a USB-compatible device, such as a USB keyboard, USB mouse, or USB storage device.

### **VGA connector**

The VGA connectors on the front and rear of the server can be used to attach a high-performance monitor, a direct-drive monitor, or other devices that use a VGA connector.

### **XClarity Controller USB connector**

The XClarity Controller USB connector can function as a regular USB 2.0 connector to the host OS. In addition, it can also be used to connect the server to an android or iOS device, where you can then install and launch the Lenovo XClarity Mobile app to manage the system using XClarity Controller.

For details about using the Lenovo XClarity Mobile app, refer to [https://pubs.lenovo.com/lxca/lxca\\_usemobileapp](https://pubs.lenovo.com/lxca/lxca_usemobileapp).

---

## **Rear view**

The rear view of the server varies by model. Depending on the model, your server might look slightly different from the illustrations in this topic.

Refer to the following rear view for different server models:

- [“Server model with three PCIe slots” on page 31](#)
- [“Server model with two PCIe slots” on page 32](#)
- [“Server model with two 2.5-inch hot-swap rear drive bays and one PCIe slot” on page 33](#)
- [“Server model with two 7mm hot-swap rear drive bays and two PCIe slots” on page 33](#)
- [“Server model with two 7mm hot-swap rear drive bays and one PCIe slot” on page 34](#)
- [“Server model with two PCIe slots and a direct water cooling module” on page 34](#)

### **Server model with three PCIe slots**

The following illustration shows the rear view of server model with three PCIe slots. Depending on the model, your server might look slightly different from the illustration below.

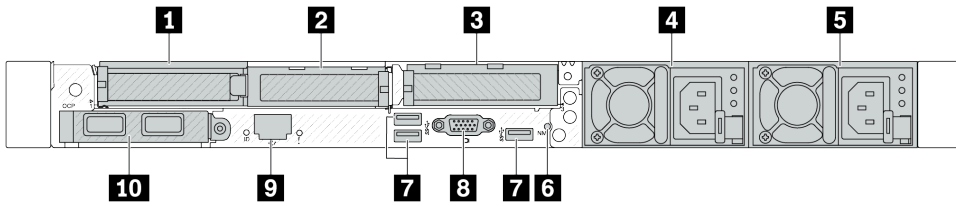

Figure 2. Rear view with three low profile PCIe adapters

Table 15. Components on the rear of the server

Callout	Callout
<b>1</b> PCIe slot 1 on riser 1 assembly	<b>2</b> PCIe slot 2 on riser 1 assembly
<b>3</b> PCIe slot 3 on riser 2 assembly	<b>4</b> Power supply 2 (optional)
<b>5</b> Power supply 1	<b>6</b> NMI button
<b>7</b> USB 3.2 Gen 1 (5Gbps) connectors (3 DCIs)	<b>8</b> VGA connector
<b>9</b> XClarity Controller network connector	<b>10</b> Ethernet connectors on OCP module (optional)

**Note:** For more information about each component, see [“Rear components overview”](#) on page 35.

### Server model with two PCIe slots

The following illustration shows the rear views of the server model with two PCIe slots. Depending on the model, your server might look slightly different from the illustration below.

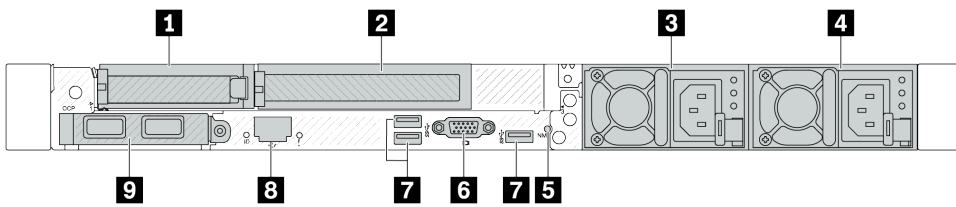

Figure 3. Rear view with one low profile PCIe adapter, one full height PCIe adapter, and one filler

Table 16. Components on the rear of the server

Callout	Callout
<b>1</b> PCIe slot 1 on riser 1 assembly	<b>2</b> PCIe slot 2 on riser 1 assembly
<b>3</b> Power supply 2 (optional)	<b>4</b> Power supply 1
<b>5</b> NMI button	<b>6</b> VGA connector
<b>7</b> USB 3.2 Gen 1 (5Gbps) connectors (3 DCIs)	<b>8</b> XClarity Controller network connector
<b>9</b> Ethernet connectors on OCP module (optional, two or four connectors may be available)	

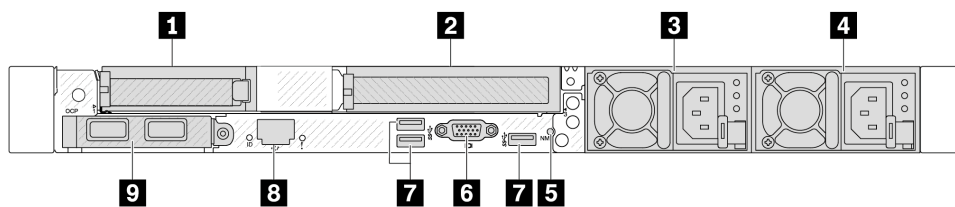

Figure 4. Rear view with one low profile PCIe adapter, one filler, and one full height PCIe adapter

Table 17. Components on the rear of the server

Callout	Callout
<b>1</b> PCIe slot 1 on riser 1 assembly	<b>2</b> PCIe slot 3 on riser 2 assembly
<b>3</b> Power supply 2 (optional)	<b>4</b> Power supply 1
<b>5</b> NMI button	<b>6</b> VGA connector
<b>7</b> USB 3.2 Gen 1 (5Gbps) connectors (3 DCIs)	<b>8</b> XClarity Controller network connector
<b>9</b> Ethernet connectors on OCP module (optional, two or four connectors may be available)	

**Note:** For more information about each component, see [“Rear components overview”](#) on page 35.

### Server model with two 2.5-inch hot-swap rear drive bays and one PCIe slot

The following illustration shows the rear view of the server model with two hot-swap drive bays and one PCIe slot. Depending on the model, your server might look slightly different from the illustration below.

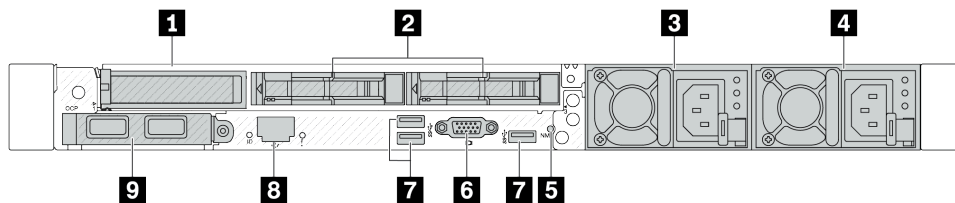

Table 18. Components on the rear of the server

<b>1</b> PCIe slot 1 on riser 1 assembly	<b>2</b> Rear 2.5-inch drive bays (2)
<b>3</b> Power supply 2 (optional)	<b>4</b> Power supply 1
<b>5</b> NMI button	<b>6</b> VGA connector
<b>7</b> USB 3.2 Gen 1 (5Gbps) connectors (3 DCIs)	<b>8</b> XClarity Controller network connector
<b>9</b> Ethernet connectors on OCP module (optional, two or four connectors may be available)	

**Note:** For more information about each component, see [“Rear components overview”](#) on page 35.

### Server model with two 7mm hot-swap rear drive bays and two PCIe slots

The following illustration shows the rear view of the server model with two 7mm hot-swap rear drive bays and two PCIe slots. Depending on the model, your server might look slightly different from the illustration below.

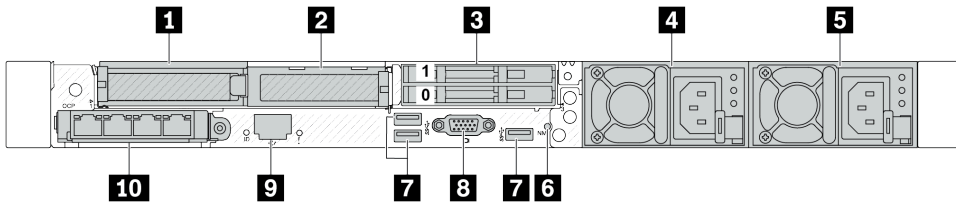

Table 19. Components on the rear of the server

<b>1</b> PCIe slot 1 on riser 1 assembly	<b>2</b> PCIe slot 2 on riser 1 assembly
<b>3</b> Rear 7mm drive bays (2)	<b>4</b> Power supply 2 (optional)
<b>5</b> Power supply 1	<b>6</b> NMI button
<b>7</b> USB 3.2 Gen 1 (5Gbps) connectors (3 DCIs)	<b>8</b> VGA connector
<b>9</b> XClarity Controller network connector	<b>10</b> Ethernet connectors on OCP module (optional, two or four connectors may be available)

**Note:** For more information about each component, see [“Rear components overview”](#) on page 35.

### Server model with two 7mm hot-swap rear drive bays and one PCIe slot

The following illustration shows the rear view of the server model with two 7mm hot-swap rear drive bays and one PCIe slots. Depending on the model, your server might look slightly different from the illustration below.

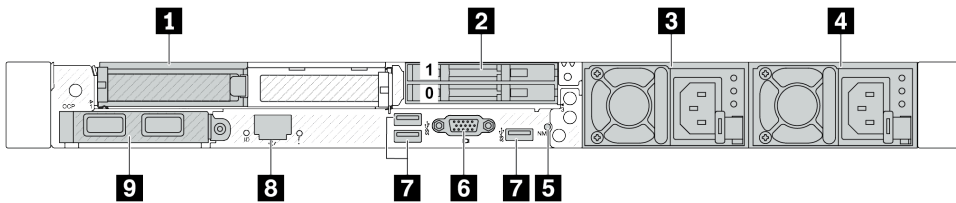

Table 20. Components on the rear of the server

<b>1</b> PCIe slot 1 on riser 1 assembly	<b>2</b> Rear 7mm drive bays (2)
<b>3</b> Power supply 2 (optional)	<b>4</b> Power supply 1
<b>5</b> NMI button	<b>6</b> VGA connector
<b>7</b> USB 3.2 Gen 1 (5Gbps) connectors (3 DCIs)	<b>8</b> XClarity Controller network connector
<b>9</b> Ethernet connectors on OCP module (optional, two or four connectors may be available)	

**Note:** For more information about each component, see [“Rear components overview”](#) on page 35.

### Server model with two PCIe slots and a direct water cooling module

The following illustration shows the rear view of the server model with two PCIe slots and a direct water cooling module. Depending on the model, your server might look slightly different from the illustration below.

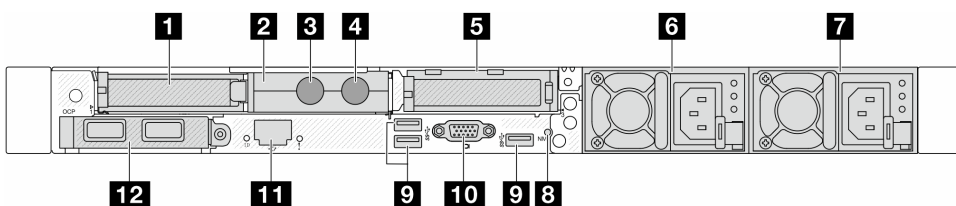

Table 21. Components on the rear of the server

<b>1</b> PCIe slot 1 on riser 1 assembly	<b>2</b> Hose holder
<b>3</b> Inlet hose	<b>4</b> Outlet hose
<b>5</b> PCIe slot 3 on riser 2 assembly	<b>6</b> Power supply 2 (optional)
<b>7</b> Power supply 1	<b>8</b> NMI button
<b>9</b> USB 3.2 Gen 1 (5Gbps) connectors (3 DCIs)	<b>10</b> VGA connector
<b>11</b> XClarity Controller network connector	<b>12</b> Ethernet connectors on OCP module (optional, two or four connectors may be available)

**Note:** For more information about each component, see [“Rear components overview”](#) on page 35.

## Rear components overview

### Ethernet connectors

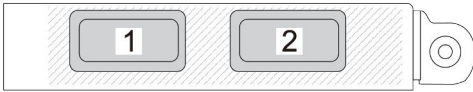

Figure 5. OCP module (two connectors)

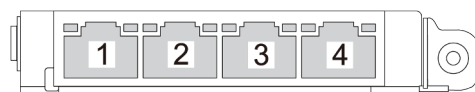

Figure 6. OCP module (four connectors)

- The OCP module provides two or four extra Ethernet connectors for network connections.
- By default, any Ethernet connector on the OCP module can also function as a management connector using the shared management capacity.

**Note:** The OCP module is an optional part. It is default to be installed in the rear and optional in the front of the server.

### Hot-swap drives and drive bays

The drive bays on the front and rear of your server are designed for hot-swap drives. The number of the installed drives in your server varies by model. When you install drives, follow the order of the drive bay numbers.

The EMI integrity and cooling of the server are protected by having all drive bays occupied. Vacant drive bays must be occupied by drive fillers.

### NMI button

Press this button to force a nonmaskable interrupt (NMI) to the processor. By this way, you can make the operating system halt (such as Windows Blue Screen of Death) and take a memory dump. You might have to use a pen or the end of a straightened paper clip to press the button.

### PCIe slots

The PCIe slots are on the rear of the server and your server supports up to three PCIe slots on riser 1 and 2 assemblies.

## Power supply units

The hot-swap redundant power supply helps you avoid significant interruption to the operation of the system when a power supply fails. You can purchase a power supply option from Lenovo and install the power supply to provide power redundancy without turning off the server.

On each power supply, there are three status LEDs near the power cord connector. For information about the LEDs, see [“System LEDs and diagnostics display” on page 46](#).

## USB 3.2 Gen 1 (5Gbps) connectors

The USB 3.2 Gen 1 (5Gbps) connectors are direct connect interfaces (DCIs) for debugging, which can be used to attach a USB-compatible device, such as a USB keyboard, USB mouse, or USB storage device.

## VGA connector

The VGA connectors on the front and rear of the server can be used to attach a high-performance monitor, a direct-drive monitor, or other devices that use a VGA connector.

## XClarity Controller network connector

The XClarity Controller network connector can be used to attach an Ethernet cable to manage the baseboard management controller (BMC).

## Rear LEDs

- For more information about the LEDs on the XCC system management port, see “LEDs on the XCC system management port” in *User Guide*.
- For more information about the system error LED and system ID LED, see “LEDs on the system board assembly” in *User Guide*.
- For more information about the LEDs on the power supply unit, see “LEDs on the power supply unit” in *User Guide*.

## Inlet and outlet hoses

The Direct Water Cooling Module (DWCM) spreads two hoses out to connect to the manifolds. The inlet hose conveys warm water from the facility to the cold plates to cool down the processors, and the outlet hose conducts hot water out of the DWCM to realize system cooling.

---

## Top view

This section contains information on the top views of the server.

The following illustrations show the top views of the server without any air baffle or rear drive cage installed.

- [“Top view with standard heat sinks” on page 36](#)
- [“Top view with liquid to air module” on page 38](#)

## Top view with standard heat sinks

This topic offers the top view of server models with standard heat sinks.

## Top view with standard heat sinks

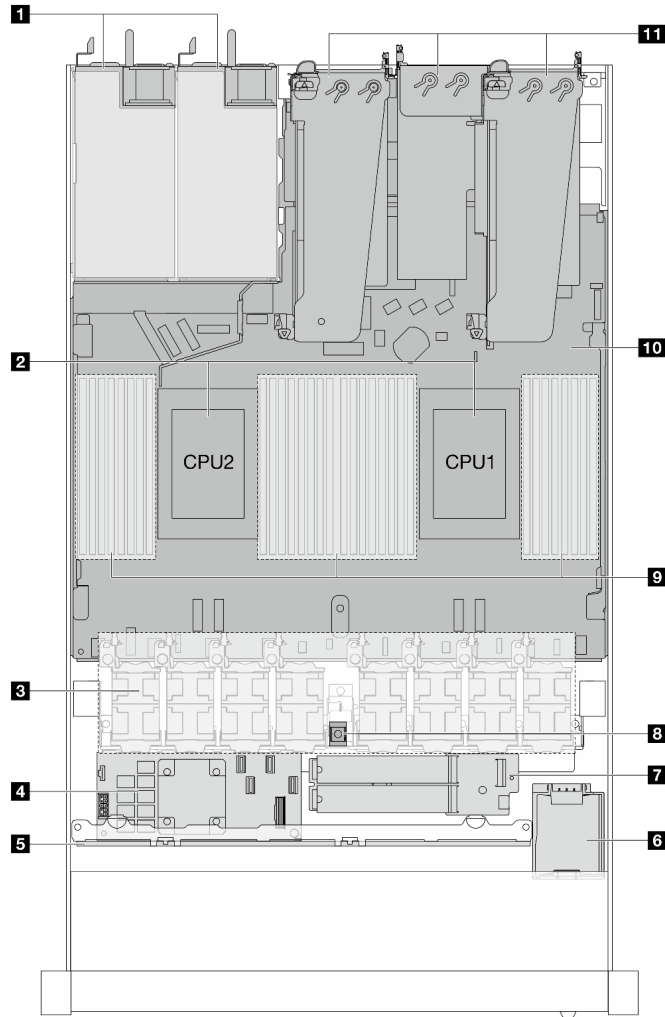

Figure 7. Top view with standard heat sinks

Table 22. Components on the top view with standard heat sinks

<b>1</b> Power supply units	<b>7</b> M.2 drive module
<b>2</b> Processors	<b>8</b> Intrusion switch
<b>3</b> Fan modules	<b>9</b> Memory modules
<b>4</b> Internal RAID adapter	<b>10</b> System board assembly
<b>5</b> Front backplane	<b>11</b> Riser assemblies
<b>6</b> RAID flash power module	

### Notes:

1. The illustration shows the server rear configuration with three riser assemblies. The server rear configurations vary by server model. For details, see [“Rear view” on page 31](#).
2. The illustration shows the location of certain parts. Some parts may not be supported at the same time within certain configuration(s).

## Top view with liquid to air module

This topic offers the top view of server models with the Liquid to Air Module (L2AM).

### Top view with the liquid to air module

The illustration below singles out the L2AM from other components in the chassis. The parts contained depend on the configuration of the server.

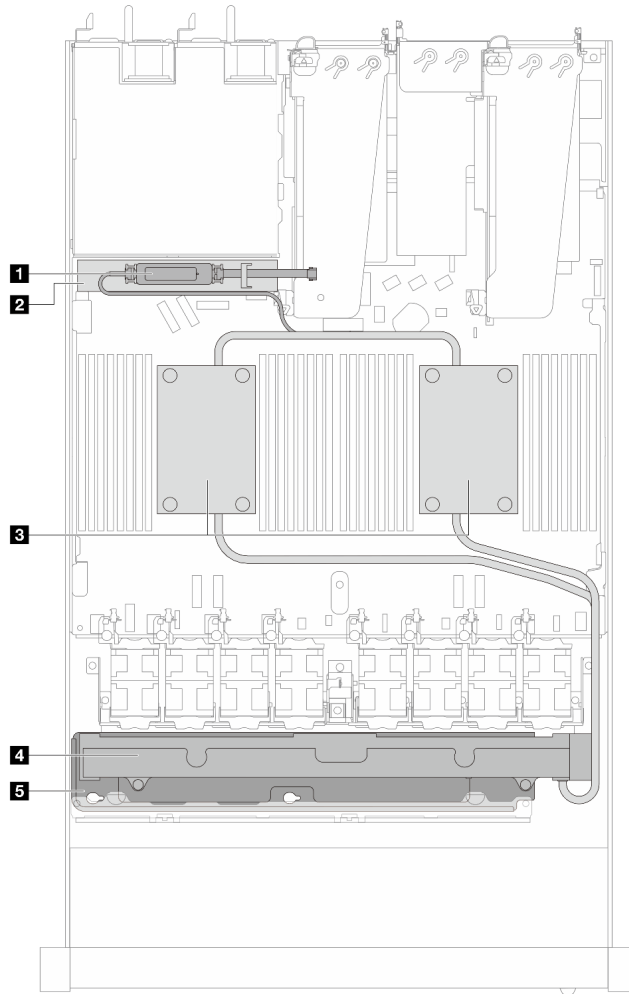

Figure 8. Top view of the L2AM

Table 23. Components on the top view of the L2AM

<b>1</b> Liquid detection sensor module	<b>4</b> Radiator
<b>2</b> The holder for the leakage detection sensor module	<b>5</b> The holder for the radiator
<b>3</b> Cold plate assembly	

## Top view with direct water cooling module

This topic offers the top view of server models with the Direct Water Cooling Module (DWCM).

## Top view with the direct water cooling module

The illustration below singles out the DWCM from other components in the chassis. The parts contained depend on the configuration of the server.

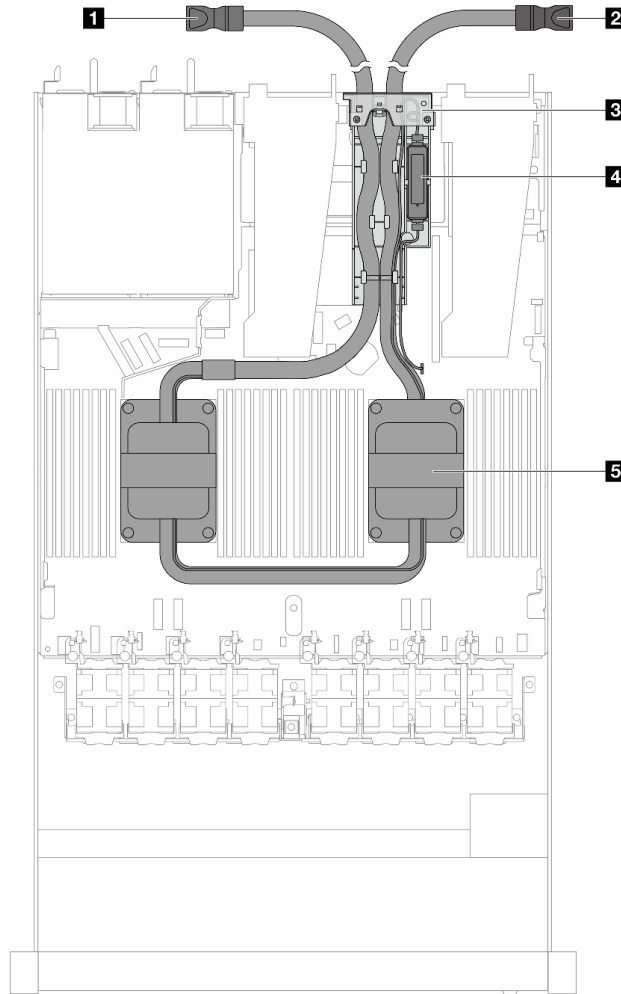

Figure 9. Top view of the DWCM

Table 24. Components on the top view of the DWCM

<b>1</b> Outlet hose	<b>4</b> The leakage detection sensor module
<b>2</b> Inlet hose	<b>5</b> Cold plate assembly
<b>3</b> Hose holder	

---

## Front I/O module

The front I/O module of the server provides controls, connectors, and LEDs. The front I/O module varies by model.

Depending on server models, your server supports the following front I/O modules.

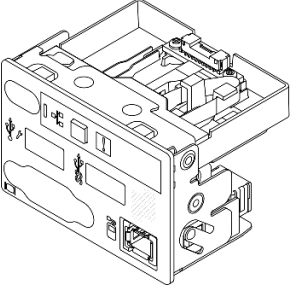
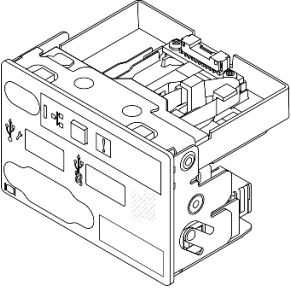
FIO modules	For server models with
 <p data-bbox="168 579 477 609"><i>Figure 10. FIO module type 1</i></p>	<ul data-bbox="594 243 902 390" style="list-style-type: none"> <li>• 4 x 2.5" front drive bays</li> <li>• 8 x 2.5" front drive bays</li> <li>• 10 x 2.5" front drive bays</li> <li>• 16 EDSFF front drive bays</li> </ul>
 <p data-bbox="168 978 477 1008"><i>Figure 11. FIO module type 2</i></p>	<ul data-bbox="594 642 902 672" style="list-style-type: none"> <li>• 10 x 2.5" front drive bays</li> </ul>

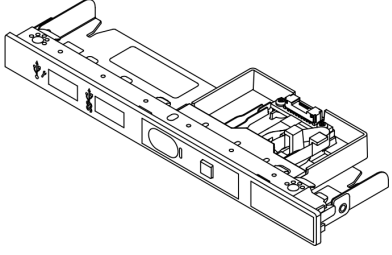
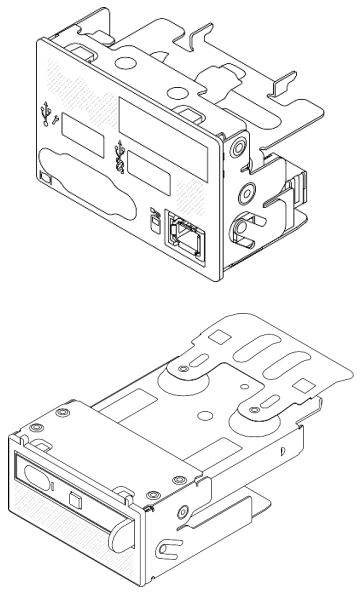
FIO modules	For server models with
 <p data-bbox="194 535 527 598"><i>Figure 12. FIO module type 3 + external LCD cable</i></p>	<ul data-bbox="625 241 909 273" style="list-style-type: none"> <li>• 4 x 3.5" front drive bays</li> </ul>
 <p data-bbox="194 1249 527 1312"><i>Figure 13. FIO module type 4 + integrated diagnostics panel</i></p>	<ul data-bbox="625 630 933 693" style="list-style-type: none"> <li>• 8 x 2.5" front drive bays</li> <li>• 16 EDSFF front drive bays</li> </ul>

## System-board-assembly layout

The illustrations in this section provide information about the layout, connectors and switches that are available on the system board assembly.

The following illustration shows the layout of the system board assembly which contains the Firmware and RoT security module, system I/O board, and processor board.

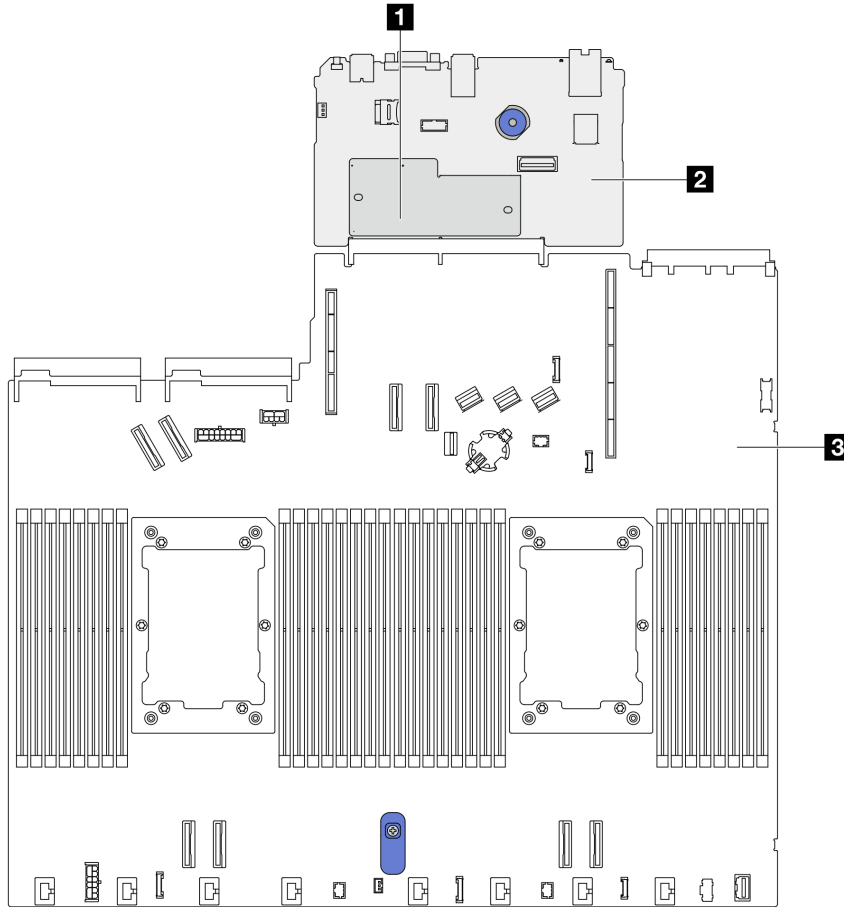

Figure 14. System-board-assembly layout

<b>1</b> Firmware and RoT Security Module	<b>2</b> System I/O board	<b>3</b> Processor board
---	---------------------------	--------------------------

For more information about the LEDs that are available on the system board assembly, see “System-board-assembly LEDs” in *User Guide* or *Hardware Maintenance Guide*.

## System-board-assembly connectors

The following illustrations show the internal connectors on the system board assembly.

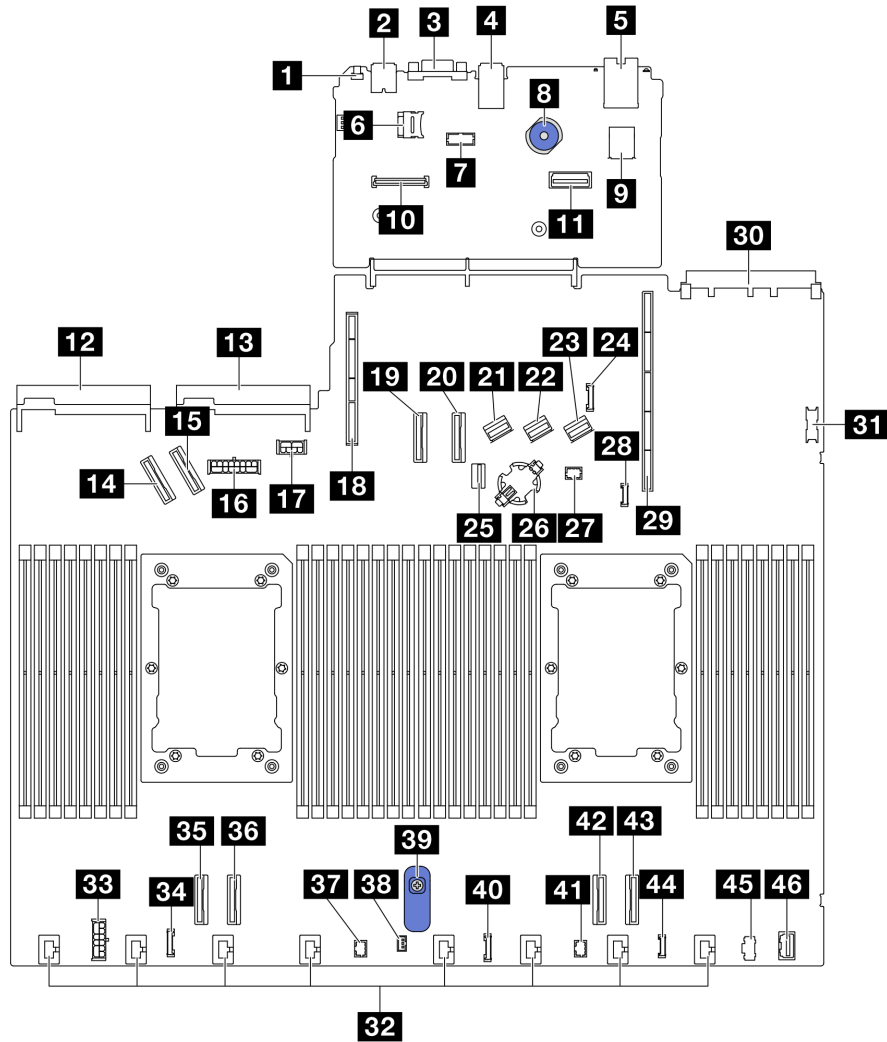

Figure 15. System-board-assembly connectors

Table 25. System-board-assembly connectors

<b>1</b> NMI button	<b>24</b> Rear backplane sideband connector
<b>2</b> Rear USB connector 1	<b>25</b> M.2/7mm backplane signal connector
<b>3</b> VGA connector	<b>26</b> CMOS battery socket
<b>4</b> Rear USB connector 2	<b>27</b> Pump 1 connector
<b>5</b> Management NIC connector	<b>28</b> Leak detection connector
<b>6</b> MicroSD card socket	<b>29</b> Riser 1 slot
<b>7</b> Serial port connector	<b>30</b> OCP 3.0 slot
<b>8</b> Plunger	<b>31</b> Front USB connector
<b>9</b> Internal USB connector	<b>32</b> Fan 1-8 connectors
<b>10</b> Firmware and RoT Security Module connector	<b>33</b> Internal RAID power connector
<b>11</b> Second management Ethernet connector	<b>34</b> CFF re-timer clock connector

Table 25. System-board-assembly connectors (continued)

<b>12</b> Power supply unit 1 connector	<b>35</b> PCIe connector 4
<b>13</b> Power supply unit 2 connector	<b>36</b> PCIe connector 3
<b>14</b> PCIe connector 5	<b>37</b> Pump 2 connector
<b>15</b> PCIe connector 6	<b>38</b> Intrusion switch connector
<b>16</b> Front backplane power connector	<b>39</b> System-board-assembly handle
<b>17</b> GPU and rear backplane power connector	<b>40</b> Front panel connector
<b>18</b> Riser 2 slot	<b>41</b> Front panel LCD connector
<b>19</b> PCIe connector 7	<b>42</b> PCIe connector 2
<b>20</b> PCIe connector 8	<b>43</b> PCIe connector 1
<b>21</b> SAS/SATA connector 0	<b>44</b> External LCD connector
<b>22</b> SAS/SATA connector 1	<b>45</b> M.2 power connector
<b>23</b> SAS/SATA connector 2	<b>46</b> Front VGA connector

## System-board-assembly switches

The following illustrations show the location of the switches on the server.

**Note:** If there is a clear protective sticker on the top of the switch blocks, you must remove and discard it to access the switches.

### Important:

- Before you change any switch settings or move any jumpers, turn off the server; then, disconnect all power cords and external cables. Review the following information:
  - [https://pubs.lenovo.com/safety\\_documentation/](https://pubs.lenovo.com/safety_documentation/)
  - “Installation Guidelines”, “Handling static sensitive devices”, and “Power off the server ” in *User Guide* or *Hardware Maintenance Guide*.
- Any system-board switch or jumper block that is not shown in the illustrations in this document are reserved.

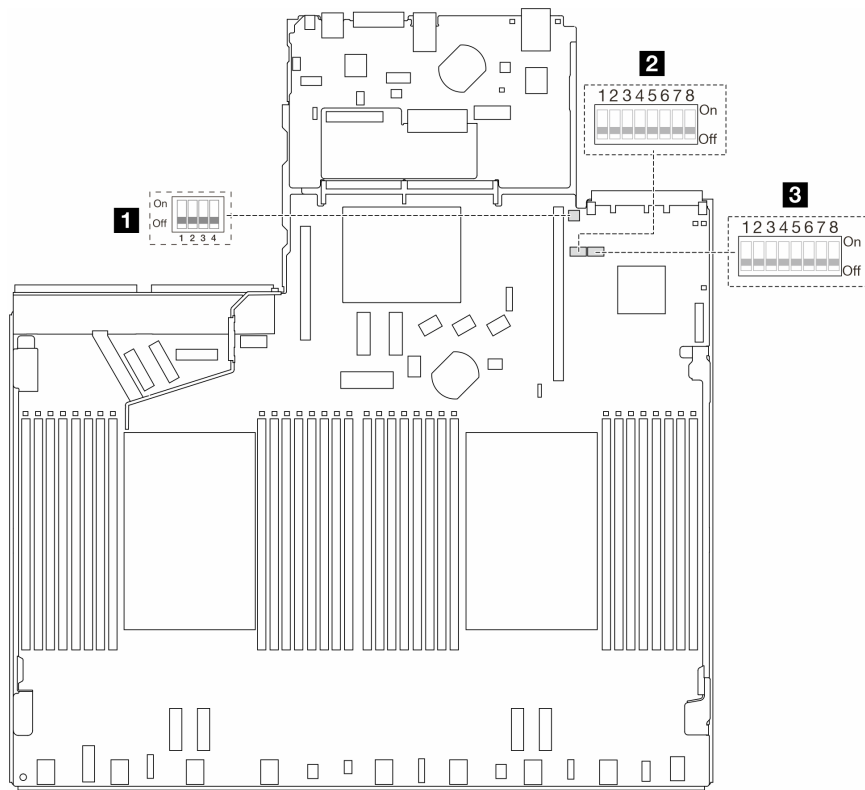

Figure 16. System-board-assembly switches

<b>1</b> “Switch 2 (SW2)” on page 45	<b>2</b> “Switch 7 (SW7)” on page 45	<b>3</b> “Switch 6 (SW6)” on page 46
--------------------------------------	--------------------------------------	--------------------------------------

### SW2 switch block

The following table describes the functions of the SW2 switch block on the system board assembly.

Table 26. SW2 switch block description

Switch-bit number	Switch name	Default position	Description
<b>1</b> SW2-1	FPGA reset	OFF	Forces FPGA into reset when switched to ON.
<b>2</b> SW2-2	Force BMC CPU reset	OFF	Forces BMC and CPU into reset when switched to ON.
<b>3</b> SW2-3	Reserved	OFF	Reserved
<b>4</b> SW2-4	BIOS image swap	OFF	Enables BIOS image swap when switched to ON.

### SW7 switch block

The following table describes the functions of the SW7 switch block on the system board assembly.

Table 27. SW7 switch block description

Switch-bit number	Switch name	Default position	Description
<b>1</b> SW7-1	XCC boot primary	OFF	XCC boots from upper half of flash region when switched to ON.
<b>2</b> SW7-2	XCC force update	OFF	XCC boots from kernel code only when switched to ON.
<b>3</b> SW7-3	Power permission override	OFF	Ignores Power Permission and allows system to power-on when switched to ON.
<b>4</b> SW7-4	Force XCC reset	OFF	Forces XCC into reset when switched to ON.
<b>5</b> SW7-5	Reserved	OFF	Reserved
<b>6</b> SW7-6	Reserved	OFF	Reserved
<b>7</b> SW7-7	Reserved	OFF	Reserved
<b>8</b> SW7-8	Reserved	OFF	Reserved

### SW6 switch block

The following table describes the functions of the SW6 switch block on the system board assembly.

Table 28. SW6 switch block description

Switch-bit number	Switch name	Default position	Description
<b>1</b> SW6-1	ME security override	OFF	Disables ME Security checks when switched to ON.
<b>2</b> SW6-2	Clear CMOS	OFF	Clears the real-time clock (RTC) registry when switched to ON.
<b>3</b> SW6-3	Password override	OFF	Overrides the power-on password when switched to ON.
<b>4</b> SW6-4	ME recovery	OFF	Boots ME into recovery mode when switched to ON.
<b>5</b> SW6-5	BIOS recovery	OFF	Boots BIOS into recovery mode when switched to ON.
<b>6</b> SW6-6	Reserved	OFF	Reserved
<b>7</b> SW6-7	Reserved	OFF	Reserved
<b>8</b> SW6-8	Reserved	OFF	Reserved

## System LEDs and diagnostics display

See the following section for information on available system LEDs and diagnostics display.

For more information, refer to [“Troubleshooting by system LEDs and diagnostics display” on page 46.](#)

## Troubleshooting by system LEDs and diagnostics display

See the following section for information on available system LEDs and diagnostics display.

## External diagnostics handset

The external LCD diagnostics handset is an external device that is connected to the server with a cable, and it allows quick access to system information such as errors, system status, firmware, network, and health information.

**Note:** The external diagnostics handset is an optional part that needs to be purchased separately.

### Location of the external diagnostics handset

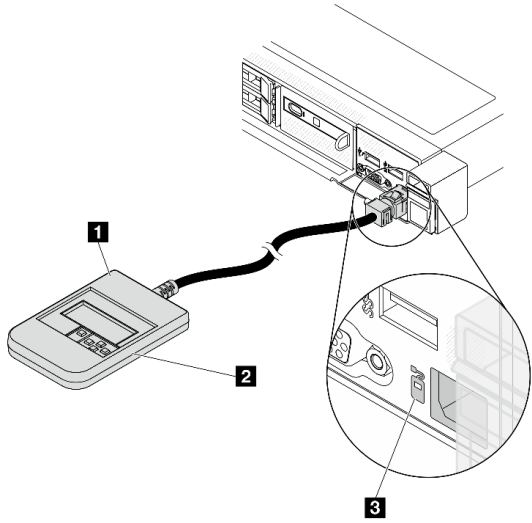
Location	Callouts
<p>The external diagnostics handset is connected to the server with an external cable.</p> 	<b>1</b> External diagnostics handset
	<b>2</b> Magnetic bottom With this component, the diagnostic handset can be attached to the top or side of the rack with hands spared for service tasks.
	<b>3</b> External diagnostics connector This connector is located on the front of the server, and is used to connect an external diagnostics handset.

**Note:** When unplugging the external handset, see the following instructions:

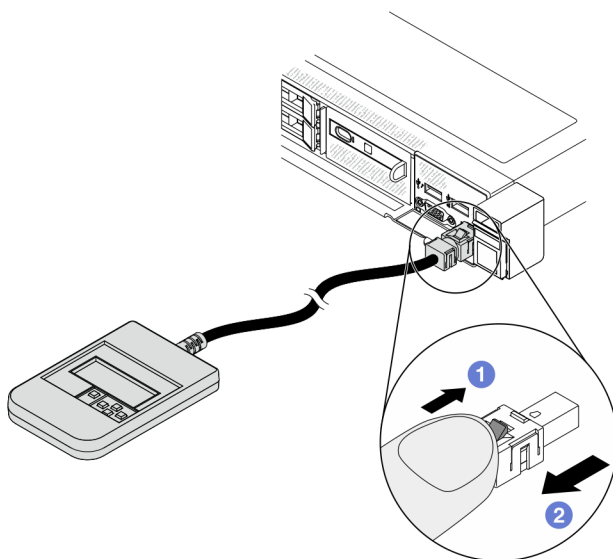

- 1** Press the plastic clip on the plug forward.
- 2** Hold the clip and remove the cable from the connector.

## Display panel overview

The diagnostics device consists of an LCD display and 5 navigation buttons.

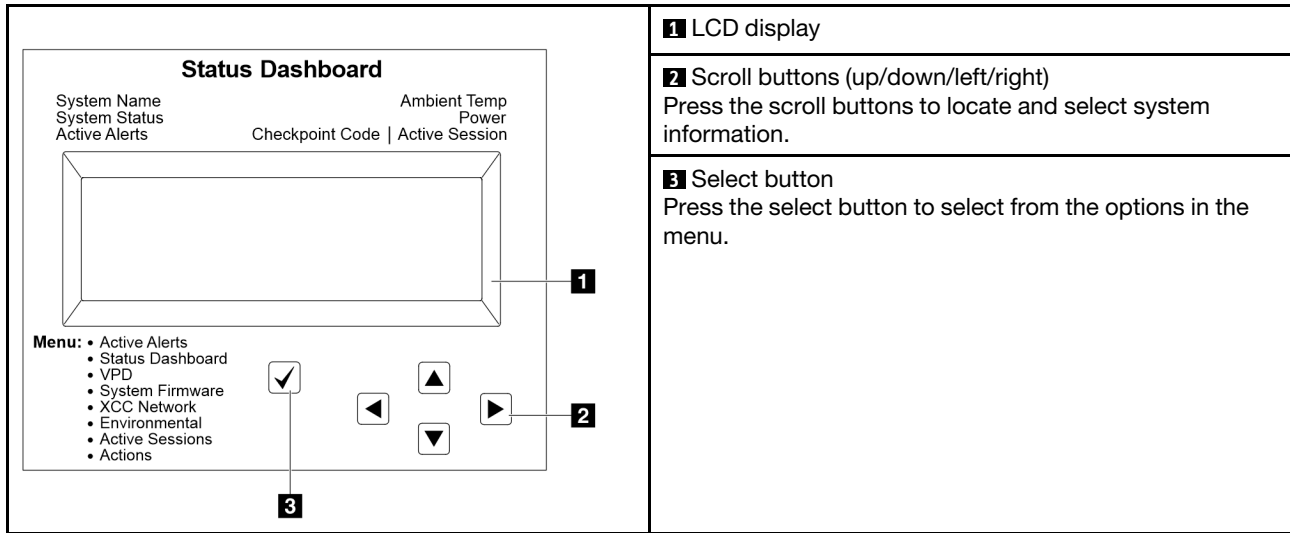

## Option flow diagram

The external diagnostics handset displays various system information. Navigate through the options with the scroll keys.

Depending on the model, the options and entries on the LCD display might be different.

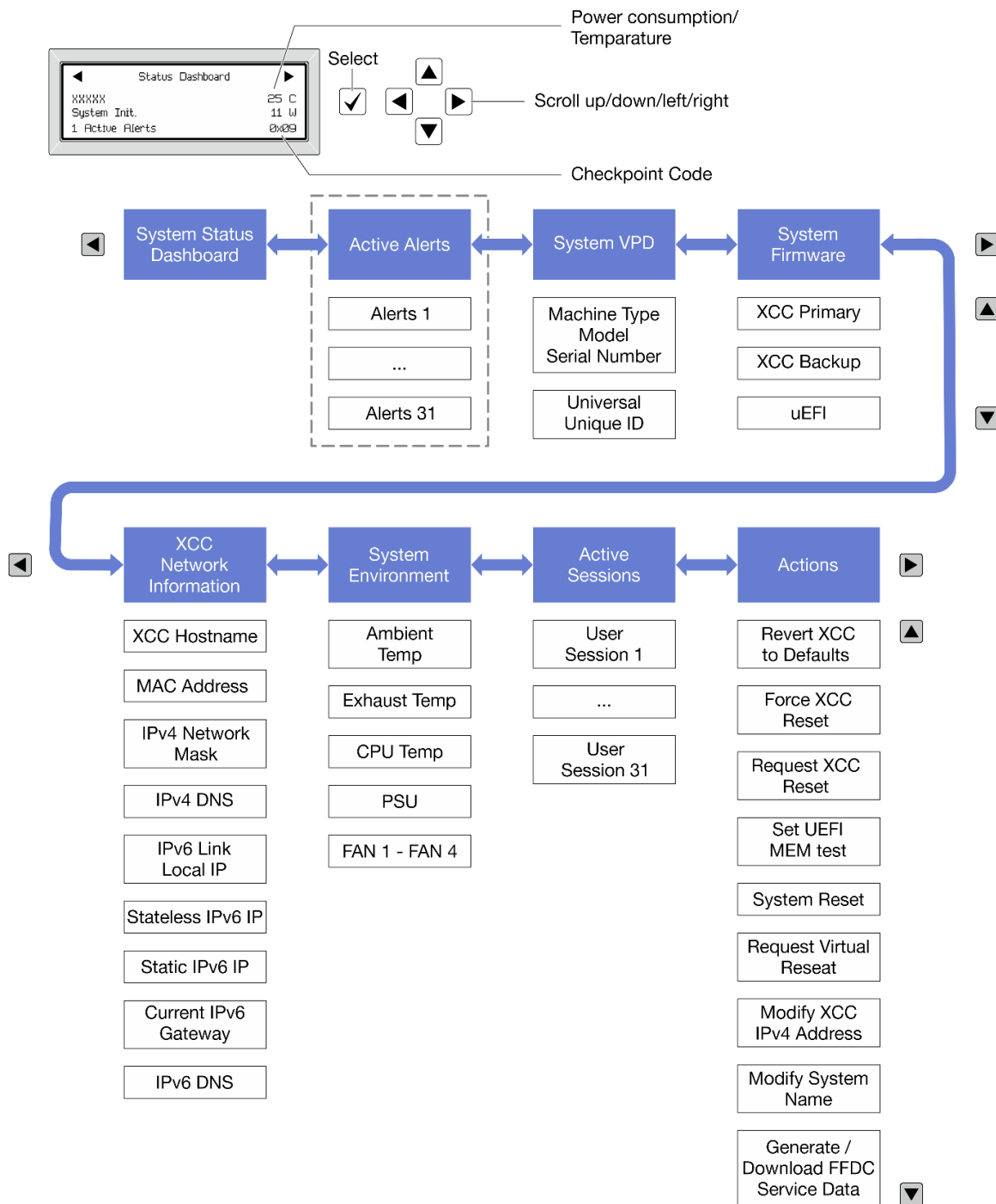

### Full menu list

Following is the list of available options. Switch between an option and the subordinate information entries with the select button, and switch among options or information entries with the scroll buttons.

Depending on the model, the options and entries on the LCD display might be different.

### Home Menu (System Status Dashboard)

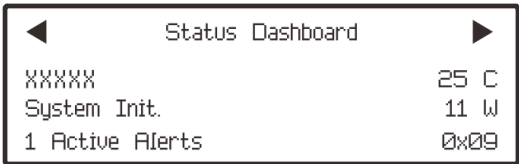
Home Menu	Example
<ul style="list-style-type: none"> <li>1 System name</li> <li>2 System status</li> <li>3 Active alert quantity</li> <li>4 Temperature</li> <li>5 Power consumption</li> <li>6 Checkpoint code</li> </ul>	

### Active Alerts

Sub Menu	Example
<p>Home screen: Active error quantity</p> <p><b>Note:</b> The “Active Alerts” menu displays only the quantity of active errors. If no errors occur, the “Active Alerts” menu will not be available during navigation.</p>	<p>1 Active Alerts</p>
<p>Details screen:</p> <ul style="list-style-type: none"> <li>• Error message ID (Type: Error/Warning/Information)</li> <li>• Occurrence time</li> <li>• Possible sources of the error</li> </ul>	<p>Active Alerts: 1</p> <p>Press ▼ to view alert details</p> <p>FQXSPPU009N(Error)</p> <p>04/07/2020 02:37:39 PM</p> <p>CPU 1 Status:</p> <p>Configuration Error</p>

### System VPD Information

Sub Menu	Example
<ul style="list-style-type: none"> <li>• Machine type and serial number</li> <li>• Universal Unique ID (UUID)</li> </ul>	<p>Machine Type: xxxx</p> <p>Serial Num: xxxxxx</p> <p>Universal Unique ID: XXXXXXXXXXXXXXXXXXXXXXXXXXXX</p>

## System Firmware

Sub Menu	Example
XCC Primary <ul style="list-style-type: none"> <li>Firmware level (status)</li> <li>Build ID</li> <li>Version number</li> <li>Release date</li> </ul>	XCC Primary (Active) Build: DVI399T Version: 4.07 Date: 2020-04-07
XCC Backup <ul style="list-style-type: none"> <li>Firmware level (status)</li> <li>Build ID</li> <li>Version number</li> <li>Release date</li> </ul>	XCC Backup (Active) Build: D8BT05I Version: 1.00 Date: 2019-12-30
UEFI <ul style="list-style-type: none"> <li>Firmware level (status)</li> <li>Build ID</li> <li>Version number</li> <li>Release date</li> </ul>	UEFI (Inactive) Build: DOE101P Version: 1.00 Date: 2019-12-26

## XCC Network Information

Sub Menu	Example
<ul style="list-style-type: none"> <li>XCC hostname</li> <li>MAC address</li> <li>IPv4 Network Mask</li> <li>IPv4 DNS</li> <li>IPv6 Link Local IP</li> <li>Stateless IPv6 IP</li> <li>Static IPv6 IP</li> <li>Current IPv6 Gateway</li> <li>IPv6 DNS</li> </ul> <p><b>Note:</b> Only the MAC address that is currently in use is displayed (extension or shared).</p>	XCC Network Information XCC Hostname: XCC-xxxx-SN MAC Address: xx:xx:xx:xx:xx:xx IPv4 IP: xx.xx.xx.xx IPv4 Network Mask: x.x.x.x IPv4 Default Gateway: x.x.x.x

## System Environmental Information

Sub Menu	Example
<ul style="list-style-type: none"> <li>• Ambient temperature</li> <li>• Exhaust temperature</li> <li>• CPU temperature</li> <li>• PSU status</li> <li>• Spinning speed of fans by RPM</li> </ul>	Ambient Temp: 24 C Exhaust Temp: 30 C CPU1 Temp: 50 C PSU1: Vin= 213 w Inlet= 26 C FAN1 Front: 21000 RPM FAN2 Front: 21000 RPM FAN3 Front: 21000 RPM FAN4 Front: 21000 RPM

## Active Sessions

Sub Menu	Example
Quantity of active sessions	Active User Sessions: 1

## Actions

Sub Menu	Example
Several quick actions are available: <ul style="list-style-type: none"> <li>• Revert XCC to Defaults</li> <li>• Force XCC Reset</li> <li>• Request XCC Reset</li> <li>• Set UEFI Memory Test</li> <li>• Request Virtual Reseat</li> <li>• Modify XCC Static IPv4 Address/Net mask/Gateway</li> <li>• Modify System Name</li> <li>• Generate/Download FFDC Service Data</li> </ul>	Request XCC Reset? This will request the BMC to reboot itself. Hold $\checkmark$ for 3 seconds

## Integrated diagnostics panel

The integrated diagnostics panel is attached to the front of the server, while it allows quick access to system information such as errors, system status, firmware, network, and health information.

## Location of the integrated diagnostics panel

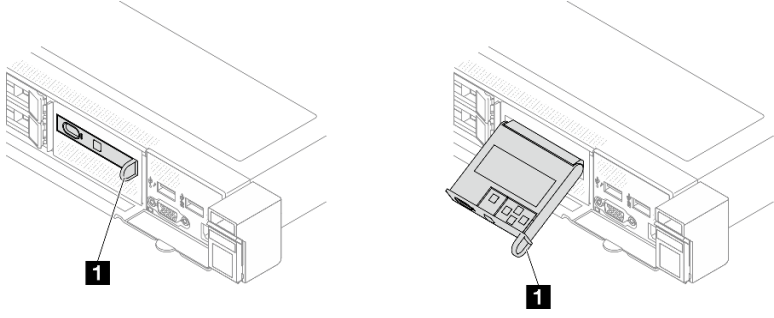
<p><b>Location</b></p>	<p>The integrated diagnostics panel is attached to the front of the server.</p> 
<p><b>Callout</b></p>	<p><b>1</b> The handle with which the panel can be pulled out from the server.</p> <p><b>Notes:</b></p> <ul style="list-style-type: none"> <li>• The panel can be pushed in or pulled out regardless of the system power status.</li> <li>• When pulling it out, do it gently to avoid damage.</li> </ul>

## Display panel overview

The diagnostics device consists of an LCD display and 5 navigation buttons.

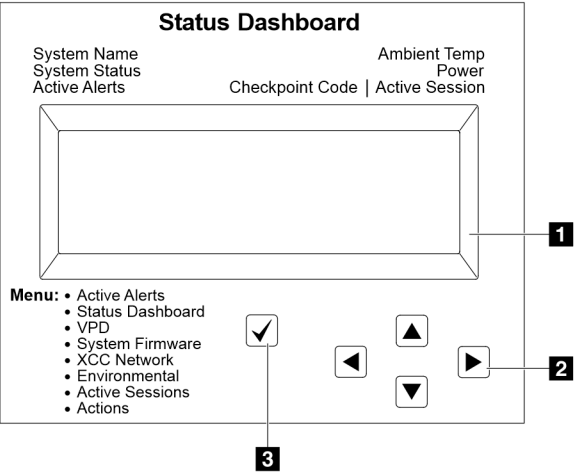
	<p><b>1</b> LCD display</p> <p><b>2</b> Scroll buttons (up/down/left/right) Press the scroll buttons to locate and select system information.</p> <p><b>3</b> Select button Press the select button to select from the options in the menu.</p>
--	---

## Option flow diagram

The external diagnostics handset displays various system information. Navigate through the options with the scroll keys.

Depending on the model, the options and entries on the LCD display might be different.

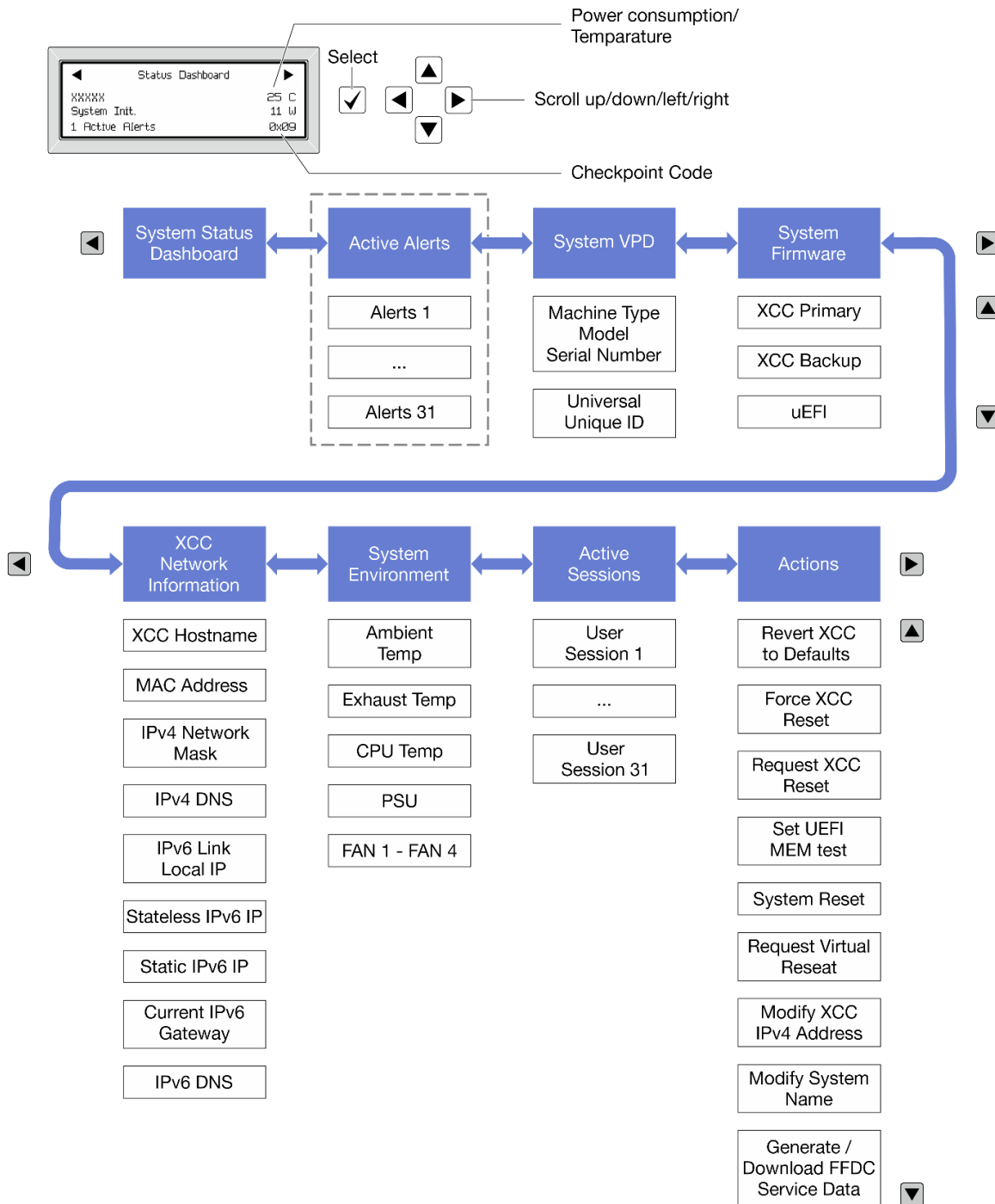

### Full menu list

Following is the list of available options. Switch between an option and the subordinate information entries with the select button, and switch among options or information entries with the scroll buttons.

Depending on the model, the options and entries on the LCD display might be different.

### Home Menu (System Status Dashboard)

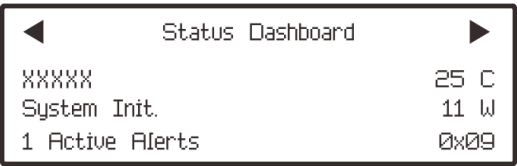
Home Menu	Example
<ul style="list-style-type: none"> <li>1 System name</li> <li>2 System status</li> <li>3 Active alert quantity</li> <li>4 Temperature</li> <li>5 Power consumption</li> <li>6 Checkpoint code</li> </ul>	

### Active Alerts

Sub Menu	Example
Home screen: Active error quantity <b>Note:</b> The “Active Alerts” menu displays only the quantity of active errors. If no errors occur, the “Active Alerts” menu will not be available during navigation.	1 Active Alerts
Details screen: <ul style="list-style-type: none"> <li>• Error message ID (Type: Error/Warning/Information)</li> <li>• Occurrence time</li> <li>• Possible sources of the error</li> </ul>	Active Alerts: 1 Press ▼ to view alert details FQXSPPU009N(Error) 04/07/2020 02:37:39 PM CPU 1 Status: Configuration Error

### System VPD Information

Sub Menu	Example
<ul style="list-style-type: none"> <li>• Machine type and serial number</li> <li>• Universal Unique ID (UUID)</li> </ul>	Machine Type: xxxx Serial Num: xxxxxx Universal Unique ID: xxxxxxxxxxxxxxxxxxxxxxxxxxxxxxxx

## System Firmware

Sub Menu	Example
XCC Primary <ul style="list-style-type: none"> <li>Firmware level (status)</li> <li>Build ID</li> <li>Version number</li> <li>Release date</li> </ul>	XCC Primary (Active) Build: DVI399T Version: 4.07 Date: 2020-04-07
XCC Backup <ul style="list-style-type: none"> <li>Firmware level (status)</li> <li>Build ID</li> <li>Version number</li> <li>Release date</li> </ul>	XCC Backup (Active) Build: D8BT05I Version: 1.00 Date: 2019-12-30
UEFI <ul style="list-style-type: none"> <li>Firmware level (status)</li> <li>Build ID</li> <li>Version number</li> <li>Release date</li> </ul>	UEFI (Inactive) Build: D0E101P Version: 1.00 Date: 2019-12-26

## XCC Network Information

Sub Menu	Example
<ul style="list-style-type: none"> <li>XCC hostname</li> <li>MAC address</li> <li>IPv4 Network Mask</li> <li>IPv4 DNS</li> <li>IPv6 Link Local IP</li> <li>Stateless IPv6 IP</li> <li>Static IPv6 IP</li> <li>Current IPv6 Gateway</li> <li>IPv6 DNS</li> </ul> <p><b>Note:</b> Only the MAC address that is currently in use is displayed (extension or shared).</p>	XCC Network Information XCC Hostname: XCC-xxxx-SN MAC Address: xx:xx:xx:xx:xx:xx IPv4 IP: xx.xx.xx.xx IPv4 Network Mask: x.x.x.x IPv4 Default Gateway: x.x.x.x

## System Environmental Information

Sub Menu	Example
<ul style="list-style-type: none"> <li>• Ambient temperature</li> <li>• Exhaust temperature</li> <li>• CPU temperature</li> <li>• PSU status</li> <li>• Spinning speed of fans by RPM</li> </ul>	Ambient Temp: 24 C Exhaust Temp: 30 C CPU1 Temp: 50 C PSU1: Vin= 213 w Inlet= 26 C FAN1 Front: 21000 RPM FAN2 Front: 21000 RPM FAN3 Front: 21000 RPM FAN4 Front: 21000 RPM

## Active Sessions

Sub Menu	Example
Quantity of active sessions	Active User Sessions: 1

## Actions

Sub Menu	Example
Several quick actions are available: <ul style="list-style-type: none"> <li>• Revert XCC to Defaults</li> <li>• Force XCC Reset</li> <li>• Request XCC Reset</li> <li>• Set UEFI Memory Test</li> <li>• Request Virtual Reseat</li> <li>• Modify XCC Static IPv4 Address/Net mask/Gateway</li> <li>• Modify System Name</li> <li>• Generate/Download FFDC Service Data</li> </ul>	Request XCC Reset? This will request the BMC to reboot itself. Hold √ for 3 seconds

## LEDs and buttons on the front operator panel

The front operator panel of the server provides controls, connectors, and LEDs.

**Note:** Diagnostics panel with an LCD display is available for some models. For details, see [“Integrated diagnostics panel” on page 52](#) and [“External diagnostics handset” on page 47](#).

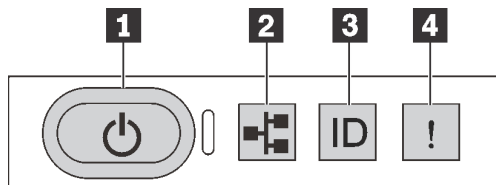

Figure 17. Diagnostics panel

### 1 Power button with power status LED

You can press the power button to power on the server when you finish setting up the server. You also can hold the power button for several seconds to power off the server if you cannot shut down the server from the operating system. The power status LED helps you determine the current power status.

Status	Color	Description
Solid on	Green	The server is on and running.
Slow blinking (about one flash per second)	Green	The server is off and is ready to be powered on (standby state).
Fast blinking (about four flashes per second)	Green	<ul style="list-style-type: none"> <li>The server is off, but the XClarity Controller is initializing, and the server is not ready to be powered on.</li> <li>System-board-assembly power has failed.</li> </ul>
Off	None	There is no ac power applied to the server.

### **2 Network activity LED**

Compatibility of the NIC adapter and the network activity LED

NIC adapter	Network activity LED
OCP module	Support
PCIe NIC adapter	Not support

When an OCP module is installed, the network activity LED on the front I/O assembly helps you identify the network connectivity and activity. If no OCP module is installed, this LED is off.

Status	Color	Description
On	Green	The server is connected to a network.
Blinking	Green	The network is connected and active.
Off	None	<p>The server is disconnected from the network.</p> <p><b>Note:</b> If the network activity LED is off when an OCP module is installed, check the network ports in the rear of your server to determine which port is disconnected.</p>

### **3 System ID button with system ID LED**

Use this system ID button and the blue system ID LED to visually locate the server. A system ID LED is also located on the rear of the server. Each time you press the system ID button, the state of both the system ID LEDs changes. The LEDs can be changed to on, blinking, or off. You can also use the Lenovo XClarity Controller or a remote management program to change the state of the system ID LEDs to assist in visually locating the server among other servers.

If the XClarity Controller USB connector is set to have both the USB 2.0 function and XClarity Controller management function, you can press the system ID button for three seconds to switch between the two functions.

### **4 System error LED**

The system error LED helps you to determine if there are any system errors.

Status	Color	Description	Action
On	Amber	<p>An error has been detected on the server. Causes might include but are not limited to the following errors:</p> <ul style="list-style-type: none"> <li>• The temperature of the server reached the non-critical temperature threshold.</li> <li>• The voltage of the server reached the non-critical voltage threshold.</li> <li>• A fan has been detected to be running at low speed.</li> <li>• A hot-swap fan has been removed.</li> <li>• The power supply has a critical error.</li> <li>• The power supply is not connected to the power.</li> <li>• A processor error.</li> <li>• A system I/O board or processor board error.</li> <li>• Abnormal status is detected on the Liquid to Air Module (L2AM) or Direct Water Cooling Module (DWCM).</li> </ul>	<ul style="list-style-type: none"> <li>• Check the Lenovo XClarity Controller event log and the system event log to determine the exact cause of the error.</li> <li>• Check if additional LEDs in the server are lit. It will direct you to the error source. See <a href="#">“Troubleshooting by system LEDs and diagnostics display”</a> on page 46.</li> <li>• Save the log if necessary.</li> </ul> <p><b>Note:</b> For server models with L2AM or DWCM installed, it is required to open the top cover to check the LED status of the leakage detection sensor module. For more instructions, see <a href="#">“The LED on the leakage detection sensor module”</a> on page 67.</p>
Off	None	The server is off or the server is on and is working correctly.	None.

## LEDs on drives

This topic provides information on drive LEDs.

Each drive comes with an activity LED and a status LED. Different colors and speeds indicate different activities or status of the drive. The following illustrations and tables describe the problems that are indicated by the activity LED and the status LED.

- [“LEDs on hard disk drives or solid-state drives”](#) on page 59
- [“LEDs on EDSFF drives”](#) on page 60

### LEDs on hard disk drives or solid-state drives

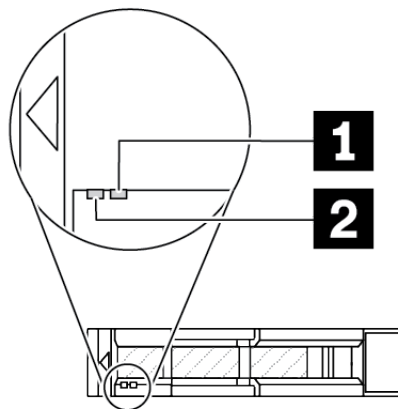

Figure 18. LEDs on hard disk drives or solid-state drives

Drive LED	Status	Description
<b>1</b> Drive status LED (right)	Solid yellow	The drive has an error.
	Blinking yellow (blinking slowly, about one flash per second)	The drive is being rebuilt.
	Blinking yellow (blinking rapidly, about four flashes per second)	The RAID adapter is locating the drive.
<b>2</b> Drive activity LED (left)	Solid green	The drive is powered but not active.
	Blinking green	The drive is active.

### LEDs on EDSFF drives

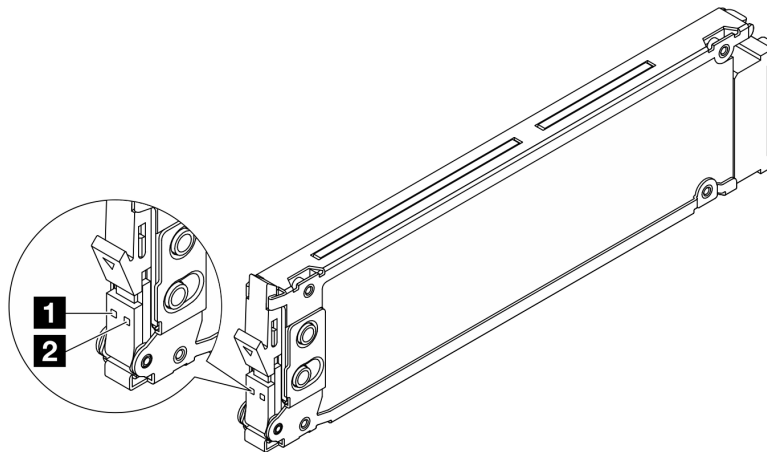

Figure 19. LEDs on EDSFF drives

Drive LED	Status	Description
<b>1</b> Drive activity LED	Solid green	The drive is powered but not active.
	Blinking green (about four flashed per second)	The drive is active.
	Off	The drive is not powered.
<b>2</b> Drive status LED	Solid amber	The drive has an error.
	Blinking amber (blinking slowly, about one flash per second)	The drive is being rebuilt.
	Blinking amber (blinking rapidly, about four flashes per second)	The RAID adapter is locating the drive.

### LEDs on the Firmware and RoT Security Module

The following illustrations show the light-emitting diodes (LEDs) on the ThinkSystem V3 Firmware and Root of Trust Security Module (Firmware and RoT Security Module).

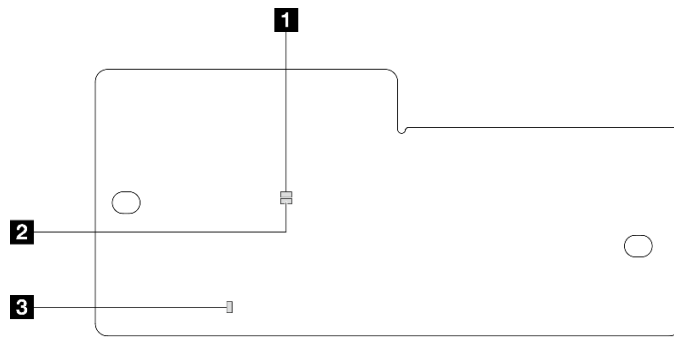

Figure 20. LEDs on the Firmware and RoT Security Module

<b>1</b> AP0 LED (Green)	<b>2</b> AP1 LED (Green)	<b>3</b> Fatal Error LED (Amber)
--------------------------	--------------------------	----------------------------------

Table 29. LEDs description

Scenario	AP0 LED	AP1 LED	Fatal Error LED	FPGA heartbeat LED <sup>note</sup>	XCC heartbeat LED <sup>note</sup>	Actions
RoT security module fatal firmware failure	Off	Off	On	N/A	N/A	Replace the Firmware and RoT Security Module.
	Blink	N/A	On	N/A	N/A	Replace the Firmware and RoT Security Module.
	Blink	N/A	On	On	N/A	Replace the Firmware and RoT Security Module.
No system power (FPGA heartbeat LED off)	Off	Off	Off	Off	Off	If the AC power is on, but the system board assembly does not have power, then: <ol style="list-style-type: none"> <li>1. Check the power supply unit (PSU) or power interposer board (PIB) if any. If the PSU or PIB has any error, replace it.</li> <li>2. If the PSU or PIB is good, do the following:               <ol style="list-style-type: none"> <li>a. Replace the system I/O board.</li> <li>b. Replace the processor board.</li> </ol> </li> </ol>
XCC firmware recoverable error	Blink	N/A	Off	N/A	N/A	Information only. No action is required.
XCC firmware is recovered from error	Blink	N/A	Off	N/A	N/A	Information only. No action is required.
UEFI firmware authentication failure	N/A	Blink	Off	N/A	N/A	Information only. No action is required.
UEFI firmware is recovered from authentication failure	N/A	On	Off	N/A	N/A	Information only. No action is required.
System is OK (FPGA heartbeat LED is On)	On	On	Off	On	On	Information only. No action is required.

**Note:** For locations of the FPGA LED and XCC heartbeat LED, see “LEDs on the system board assembly” on page 62.

## LEDs on the system board assembly

The following illustrations show the light-emitting diodes (LEDs) on the system board assembly.

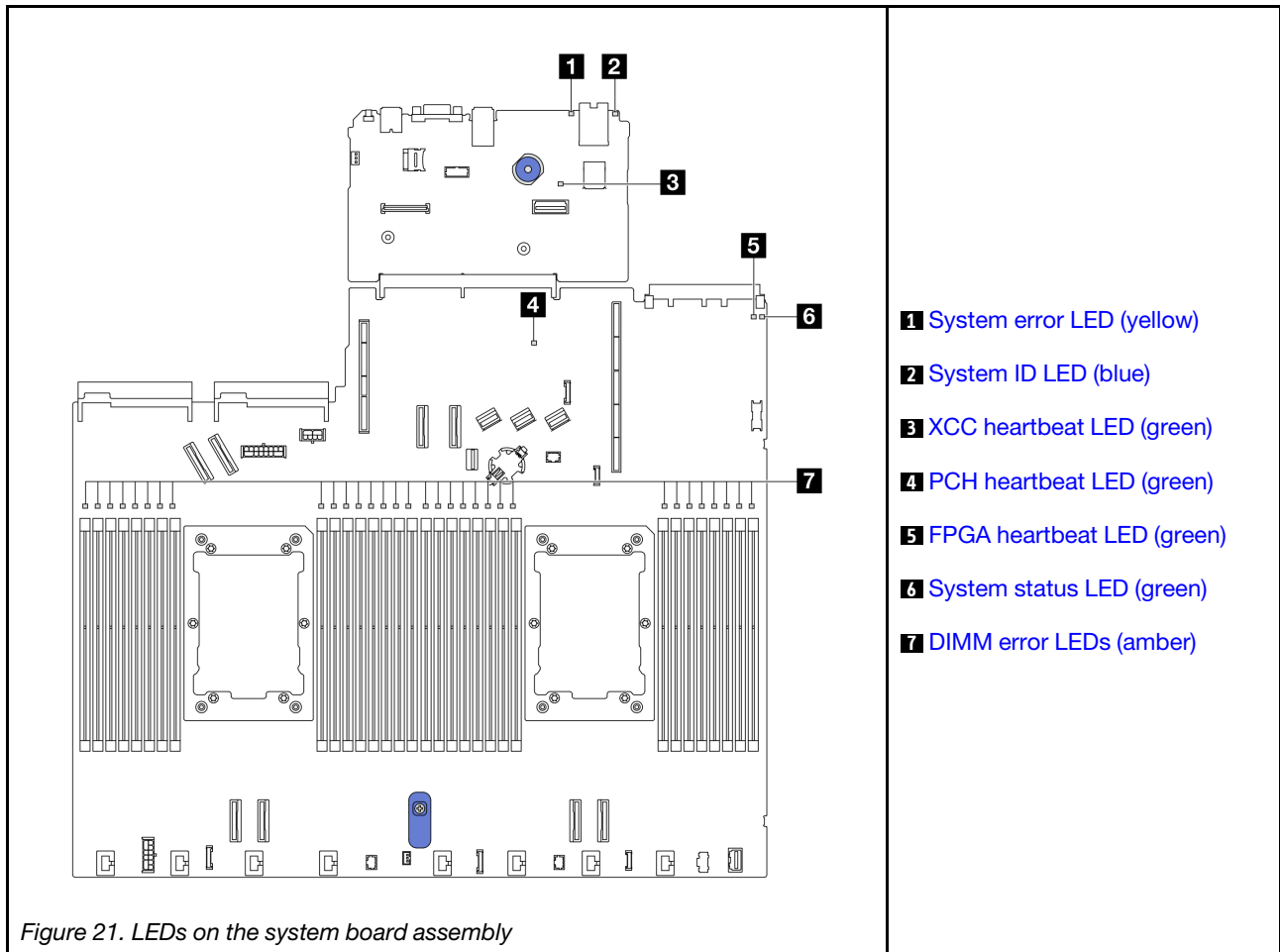

### Descriptions of LEDs on the system board assembly

<b>1 System error LED (yellow)</b>	
Description	When this yellow LED is lit, another one or more LEDs in the server might also be lit to direct you to the error source.
Action	Check system logs or internal error LEDs to identify the failed part. For more information, see “LEDs and buttons on the front operator panel” on page 57.

<b>2 System ID LED (blue)</b>	
Description	The front system ID LED helps you locate the server.
Action	Each time you press the system ID button, the state of both system ID LEDs changes, and the state can be on, blinking, or off.

<b>3 XCC heartbeat LED (green)</b>	
Description	<p>The XCC heartbeat LED helps you identify the XCC status.</p> <ul style="list-style-type: none"> <li>• Blinking (about one flash per second) : XCC is working normally.</li> <li>• Blinking at other speeds or always on: XCC is at the initial phase or is working abnormally.</li> <li>• Off: XCC is not working.</li> </ul>
Action	<ul style="list-style-type: none"> <li>• If the XCC heartbeat LED is always off or always on, do the following: <ul style="list-style-type: none"> <li>– If XCC cannot be accessed: <ol style="list-style-type: none"> <li>1. Re-plug the power cord.</li> <li>2. Check and ensure that the system I/O board and the Firmware and RoT Security Module are installed correctly. (Trained technicians only) Reinstall them if needed.</li> <li>3. (Trained technicians only) Replace the Firmware and RoT Security Module.</li> <li>4. (Trained technicians only) Replace the system I/O board.</li> </ol> </li> <li>– If XCC can be accessed, replace the system I/O board.</li> </ul> </li> <li>• If the XCC heartbeat LED is always blinking fast over 5 minutes, do the following: <ol style="list-style-type: none"> <li>1. Re-plug the power cord.</li> <li>2. Check and ensure that the system I/O board and the Firmware and RoT Security Module are installed correctly. (Trained technicians only) Reinstall them if needed.</li> <li>3. (Trained technicians only) Replace the Firmware and RoT Security Module.</li> <li>4. (Trained technicians only) Replace the system I/O board.</li> </ol> </li> <li>• If the XCC heartbeat LED is always blinking slow over 5 minutes, do the following: <ol style="list-style-type: none"> <li>1. Re-plug the power cord.</li> <li>2. Check and ensure that the system I/O board and the Firmware and RoT Security Module are installed correctly. (Trained technicians only) Reinstall them if needed.</li> <li>3. If the problem remains, contact Lenovo Support.</li> </ol> </li> </ul>

<b>4 PCH heartbeat LED (green)</b>	
Description	<p>The PCH heartbeat LED helps you identify the PCH status.</p> <ul style="list-style-type: none"> <li>• Blinking (about one flash per second): system ME is working normally.</li> <li>• Off: system ME is not working.</li> </ul>
Action	<p>If the PCH heartbeat LED is always off or always on, do the following:</p> <ol style="list-style-type: none"> <li>1. Check and ensure that the system I/O board and the Firmware and RoT Security Module are installed correctly. (Trained technicians only) Reinstall them if needed.</li> <li>2. Make sure the UEFI firmware has been flashed to the corresponding platform version.</li> <li>3. Update UEFI and XCC firmware to the latest version.</li> <li>4. Check if there is an ME error event triggered in system event log. If yes, and the above actions are done, replace the Firmware and RoT Security Module.</li> <li>5. (Trained technicians only) If it is still not working, replace the processor board.</li> </ol>

<b>5 FPGA heartbeat LED (green)</b>	
Description	<p>The FPGA heartbeat LED helps you identify the FPGA status.</p> <ul style="list-style-type: none"> <li>Blinking (about one flash per second): FPGA is working normally.</li> <li>On or off: FPGA is not working.</li> </ul>
Action	<p>If FPGA heartbeat LED is always off or always on, do the following:</p> <ol style="list-style-type: none"> <li>Replace the processor board.</li> <li>If the problem remains, contact Lenovo Support.</li> </ol>

<b>6 System status LED (green)</b>	
Description	<p>The system status LED indicates the working status of the system.</p> <ul style="list-style-type: none"> <li>Fast blinking (about four flashes per second): Power fault or is waiting for XCC power permission ready.</li> <li>Slow blinking (about one flash per second): Power off and is ready to be powered on (standby state).</li> <li>On: Power on.</li> </ul>
Action	<ul style="list-style-type: none"> <li>If the system status LED is blinking fast over 5 minutes and cannot power on, check the XCC heartbeat LED and follow the <a href="#">actions for the XCC heartbeat LED</a>.</li> <li>If the system status LED remains off or is blinking fast (about four flashes per second) and the system error LED on the front panel is on (yellow), the system is in a power fault status. Do the following: <ol style="list-style-type: none"> <li>Re-plug the power cord.</li> <li>Remove installed adapters/devices, one at a time, until you reach the minimal configuration for debugging.</li> <li>(Trained technicians only) If the problem remains, capture FFDC log, and replace the processor board.</li> <li>If the problem still remains, contact Lenovo Support.</li> </ol> </li> </ul>

<b>7 DIMM error LEDs (amber)</b>	
Description	<p>When a memory module error LED is lit, it indicates that the corresponding memory module has failed.</p>
Action	<p>For more information, see "Memory problems" in the <i>User Guide</i>.</p>

## Demo video

[Watch blinking symptoms of system status LED on YouTube](#)

## Rear LEDs

This topic provides an overview of the LEDs on the rear of the server.

### Rear LEDs of the server

The following illustration shows the LEDs on the rear view of server model with two PCIe slots and a two-bay 7mm drive cage. The LEDs on the rear view of other server models are the same.

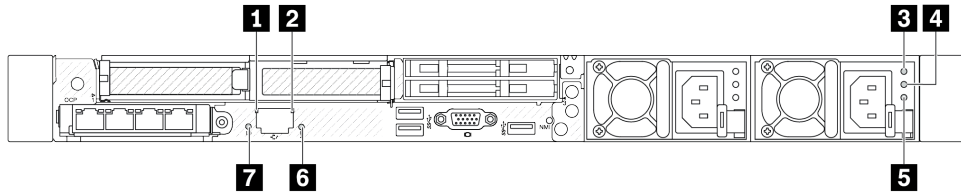

Figure 22. Rear LEDs overview

Callout	LED
<b>1 2</b>	<a href="#">“LEDs on the XCC system management port” on page 66</a>
<b>3 4 5</b>	<a href="#">“LEDs on the power supply unit” on page 65</a>
<b>6 7</b>	<a href="#">Rear system LEDs</a>

### LEDs on the power supply unit

This topic provides information about various power supply unit LED status and corresponding action suggestions.

The following minimal configuration is required for the server to start:

- One processor in processor socket 1
- One memory module in slot 7
- One power supply unit
- One HDD/SSD drive, one M.2 drive, or one 7mm drive (if OS is needed for debugging)
- Six system fans (with one processor)

The following table describes the problems that are indicated by various combinations of the power-supply unit LEDs and the power-on LED and suggested actions to correct the detected problems.

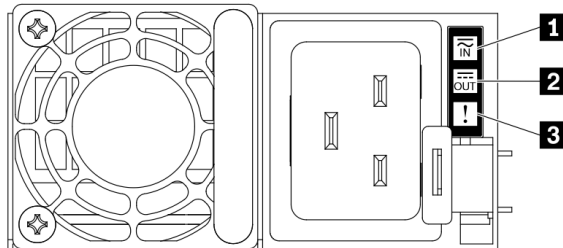

Figure 23. LEDs on the power supply unit

LED	Description
<b>1</b> Input status	<p>The input status LED can be in one of the following states:</p> <ul style="list-style-type: none"> <li>• Off: The power supply unit is disconnected from the input power source.</li> <li>• Green: The power supply unit is connected to the input power source.</li> </ul>
<b>2</b> Output status	<p>The output status LED can be in one of the following states:</p> <ul style="list-style-type: none"> <li>• Off: The server is powered off, or the power supply unit is not working properly. If the server is powered on but the output status LED is off, replace the power supply unit.</li> <li>• Slow blinking green (about one flash every two seconds): The power supply unit is in cold redundancy active mode.</li> <li>• Fast blinking green (about 2 flashes each second): The power supply unit is in cold redundancy sleep mode.</li> <li>• Green: The server is on and the power supply unit is working normally.</li> </ul> <p>Zero-output mode can be disabled via Setup Utility or Lenovo XClarity Controller web interface. If you disable zero-output mode, both power supplies will be in the active state.</p> <ul style="list-style-type: none"> <li>• Start the Setup Utility, go to <b>System Settings → Power → Zero Output</b> and select <b>Disable</b>. If you disable zero-output mode, both power supplies will be in the active state.</li> <li>• Log in to the Lenovo XClarity Controller web interface, choose <b>Server Configuration → Power Policy</b>, disable <b>Zero Output Mode</b>, and then click <b>Apply</b>.</li> </ul>
<b>3</b> Fault LED	<ul style="list-style-type: none"> <li>• Off: The power supply unit is working normally.</li> <li>• Yellow: The power supply unit may have failed. Dump the FFDC log from the system and contact Lenovo back end support team for PSU data log reviewing.</li> </ul>

### LEDs on the XCC system management port

This topic provides information on LEDs of XCC system management port.

The following table describes the problems that are indicated by LEDs on XCC system management port.

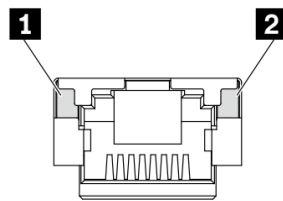

Figure 24. LEDs on the XCC system management port

LED	Description
<b>1</b> XCC system management port (1 GB RJ-45) Ethernet port link LED	<p>Use this green LED to distinguish the network connectivity status:</p> <ul style="list-style-type: none"> <li>• Off: The network link is disconnected.</li> <li>• Green: The network link is established.</li> </ul>
<b>2</b> XCC system management port (1 GB RJ-45) Ethernet port activity LED	<p>Use this green LED to distinguish the network activity status:</p> <ul style="list-style-type: none"> <li>• Off: The server is disconnected from a LAN.</li> <li>• Green: The network is connected and active.</li> </ul>

## The LED on the leakage detection sensor module

This topic provides information about the LED on the leakage detection sensor module.

The leakage detection sensor module on the Liquid to Air Module (L2AM) or Direct Water Cooling Module (DWCM) comes with one LED. The following illustration shows the LED on the module.

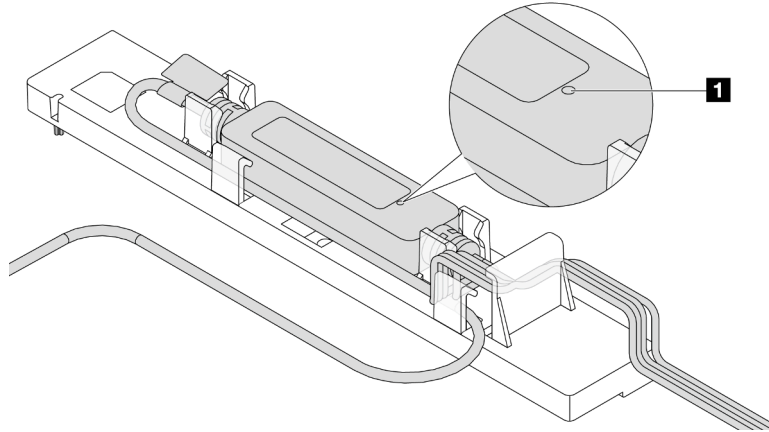

Figure 25. Leak detection LED

The following table describes the status that are indicated by the leakage detection sensor module LED.

<b>1 Leakage detection sensor LED</b>	
Description	<ul style="list-style-type: none"><li>• Solid green: No coolant leakage detected.</li><li>• Blinking green: Abnormal status detected.</li></ul>
Action	<ul style="list-style-type: none"><li>• For L2AM problem determination and troubleshooting, see “Coolant leak problems (Liquid Assisted Cooling Module)” in <i>User Guide</i> and <i>Hardware Maintenance Guide</i>.</li><li>• For DWCM problem determination and troubleshooting, see “Coolant leak problems (Direct Water Cooling Module)” in <i>User Guide</i> and <i>Hardware Maintenance Guide</i>.</li></ul>



---

## Chapter 3. Parts list

Identify each of the components that is available for your server with the parts list.

For more information about ordering parts:

1. Go to <http://datacentersupport.lenovo.com>, and enter the model name or machine type of your server in the search bar to navigate to the support page.
2. Click **Parts**.
3. Enter the serial number to view a listing of parts for your server.

It is highly recommended that you check the power summary data for your server using Lenovo Capacity Planner before purchasing any new parts.

**Note:** Depending on the model, your server might look slightly different from the illustration.

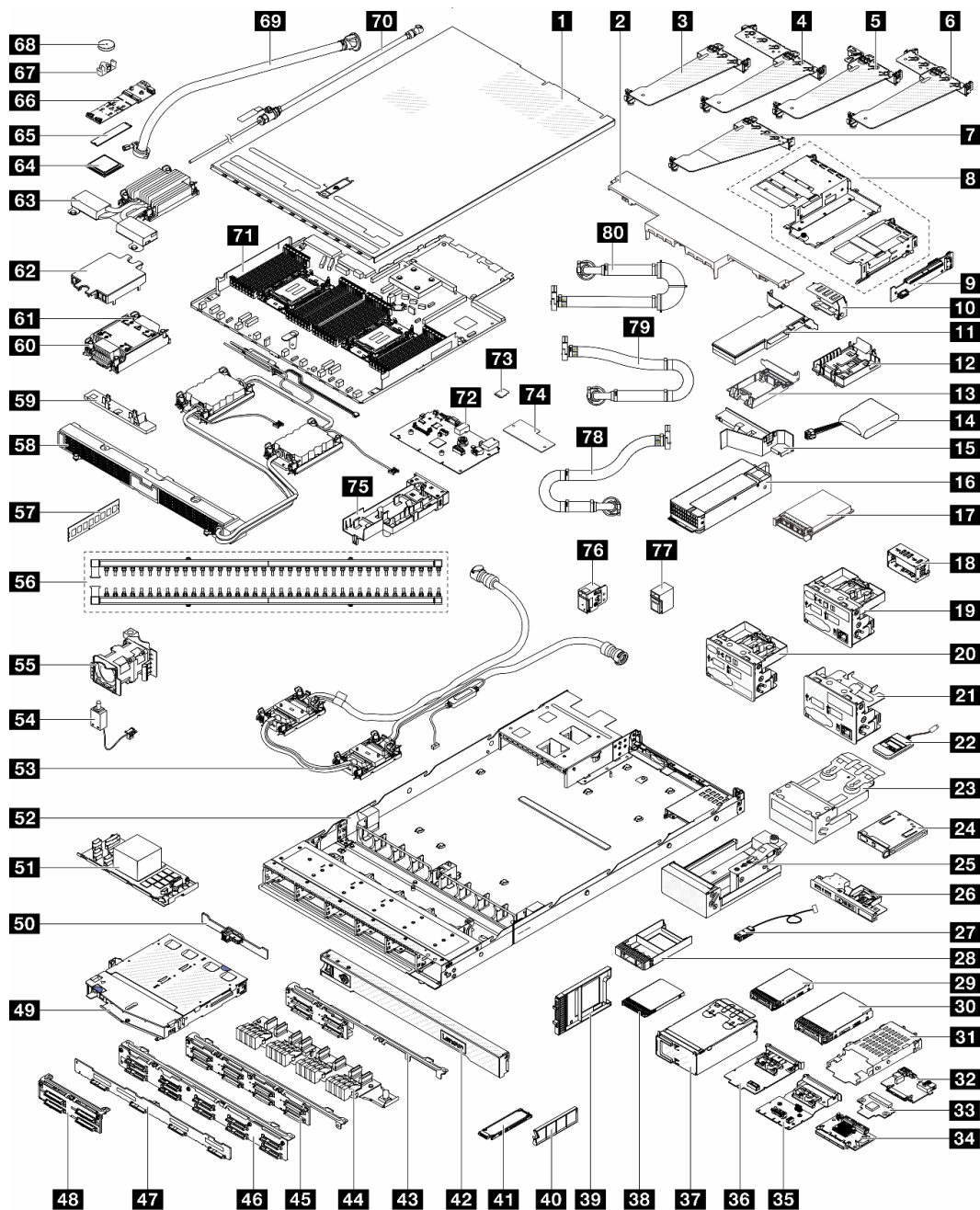

Figure 26. Server components

The parts listed in the following table are identified as one of the following:

- **T1:** Tier 1 customer replaceable unit (CRU). Replacement of Tier 1 CRUs is your responsibility. If Lenovo installs a Tier 1 CRU at your request with no service agreement, you will be charged for the installation.
- **T2:** Tier 2 customer replaceable unit (CRU). You may install a Tier 2 CRU yourself or request Lenovo to install it, at no additional charge, under the type of warranty service that is designated for your server.
- **FRU:** Field replaceable unit (FRU). FRUs must be installed only by trained service technicians.
- **C:** Consumable and Structural parts. Purchase and replacement of consumable and structural parts is your responsibility. If Lenovo acquires or installs a structural component at your request, you will be charged for the service.

Description	Type	Description	Type
<b>1</b> Top cover	T1	<b>2</b> Standard air baffle	T1
<b>3</b> Riser bracket (low profile, LP)	C	<b>4</b> Riser bracket (low profile-full height, LP-FH)	T1
<b>5</b> Riser bracket (low profile-filler, LP-filler)	T1	<b>6</b> Riser bracket (low profile-low profile, LP-LP)	T1
<b>7</b> Rear riser bracket (full height, FH)	T1	<b>8</b> Front riser cages	C
<b>9</b> Riser card	T2	<b>10</b> Rear wall bracket	C
<b>11</b> PCIe adapter	T1	<b>12</b> RAID flash power module holder (on chassis)	T1
<b>13</b> RAID flash power module holder (in riser bracket)	T1	<b>14</b> RAID flash power module	T1
<b>15</b> Power-supply-unit air baffle	T1	<b>16</b> Power supply unit	T1
<b>17</b> OCP module	T1	<b>18</b> Power-supply-unit filler	C
<b>19</b> Front I/O module with diagnostics panel (1)	T1	<b>20</b> Front I/O module with diagnostics panel (2)	T1
<b>21</b> Front I/O module (3)	T1	<b>22</b> External diagnostics handset	T1
<b>23</b> Integrated diagnostics panel assembly	T1	<b>24</b> Integrated diagnostics panel	T1
<b>25</b> M.2 cage	T1	<b>26</b> Front I/O module with diagnostics panel (4)	T1
<b>27</b> External LCD cable	T1	<b>28</b> 2.5-inch drive bay filler	C
<b>29</b> 2.5-inch drive	T1	<b>30</b> 3.5-inch drive	T1
<b>31</b> 7mm drive cage	T1	<b>32</b> 7mm drive backplane (bottom)	T2
<b>33</b> 7mm drive backplane (top)	T2	<b>34</b> Front OCP interposer card	T2
<b>35</b> Management NIC adapter	T2	<b>36</b> Rear OCP interposer card	T1
<b>37</b> 4-EDSFF cage	T1	<b>38</b> 7mm drive	T1
<b>39</b> 7mm drive bay filler	C	<b>40</b> EDSFF drive bay filler	C
<b>41</b> EDSFF drive	T1	<b>42</b> Security bezel	C
<b>43</b> 4 x 2.5-inch front drive backplane (long bracket)	T1	<b>44</b> 16-EDSFF front drive backplane	T1
<b>45</b> 8 x 2.5-inch front drive backplane	T1	<b>46</b> 10 x 2.5-inch front drive backplane (10 x AnyBay)	T2
		<b>46</b> 10 x 2.5-inch front drive backplane (6 x SAS/SATA + 4 x AnyBay)	T1
<b>47</b> 4 x 3.5-inch front drive backplane	T1	<b>48</b> 4 x 2.5-inch front drive backplane (short bracket)	T2
<b>49</b> 2 x 2.5-inch rear drive cage	C	<b>50</b> 2 x 2.5-inch rear drive backplane	T1
<b>51</b> Internal RAID adapter	T2	<b>52</b> Chassis	FRU
<b>53</b> Lenovo Neptune Processor Direct Water Cooling Module	FRU	<b>54</b> Intrusion switch	T1
<b>55</b> System fan	T1	<b>56</b> Manifolds	FRU
<b>57</b> Memory module	T1	<b>58</b> Lenovo Neptune Liquid to Air Cooling Module	FRU
<b>59</b> Leakage detection sensor module holder	C	<b>60</b> Heat sink PEEK nut	T2

Description	Type	Description	Type
<b>61</b> Standard heat sink	FRU	<b>62</b> Cold plate cover	C
<b>63</b> Performance heat sink (T-shape)	FRU	<b>64</b> Processor	FRU
<b>65</b> M.2 drive	T1	<b>66</b> M.2 backplane	T1
<b>67</b> M.2 retainer clip	T1	<b>68</b> CMOS battery	C
<b>69</b> 42U in-row hose kit	FRU	<b>70</b> Bleeder kit	FRU
<b>71</b> Processor board	FRU	<b>72</b> System I/O board	FRU
<b>73</b> MicroSD card	T1	<b>74</b> Firmware and RoT Security Module	FRU
<b>75</b> Hose holder	C	<b>76</b> Rack latch (left)	T1
<b>77</b> Rack latch (right)	T1	<b>78</b> 42U/48U in-rack connection hose (return side)	FRU
<b>79</b> 48U in-rack connection hose (supply side)	FRU	<b>80</b> 42U in-rack connection hose (supply side)	FRU

## Power cords

Several power cords are available, depending on the country and region where the server is installed.

To view the power cords that are available for the server:

1. Go to:  
<http://dcsc.lenovo.com/#/>
2. Click **Preconfigured Model** or **Configure to order**.
3. Enter the machine type and model for your server to display the configurator page.
4. Click **Power** → **Power Cables** to see all line cords.

### Notes:

- For your safety, a power cord with a grounded attachment plug is provided to use with this product. To avoid electrical shock, always use the power cord and plug with a properly grounded outlet.
- Power cords for this product that are used in the United States and Canada are listed by Underwriter's Laboratories (UL) and certified by the Canadian Standards Association (CSA).
- For units intended to be operated at 115 volts: Use a UL-listed and CSA-certified cord set consisting of a minimum 18 AWG, Type SVT or SJT, three-conductor cord, a maximum of 15 feet in length and a parallel blade, grounding-type attachment plug rated 15 amperes, 125 volts.
- For units intended to be operated at 230 volts (U.S. use): Use a UL-listed and CSA-certified cord set consisting of a minimum 18 AWG, Type SVT or SJT, three-conductor cord, a maximum of 15 feet in length and a tandem blade, grounding-type attachment plug rated 15 amperes, 250 volts.
- For units intended to be operated at 230 volts (outside the U.S.): Use a cord set with a grounding-type attachment plug. The cord set should have the appropriate safety approvals for the country in which the equipment will be installed.
- Power cords for a specific country or region are usually available only in that country or region.

---

## Chapter 4. Unboxing and setup

Information in this section assists you on unboxing and setting up the server. When unboxing the server, check if the items in the package are correct, and learn where to find information of server serial number and Lenovo XClarity Controller access. Make sure to follow the instructions in [“Server setup checklist” on page 75](#) when setting up the server.

---

### Server package contents

When you receive your server, verify that the shipment contains everything that you expected to receive.

The server package includes the following items:

- Server
- Rail installation kit\*. Installation guide is provided in the package.
- Cable management arm\*. Installation guide is provided in the package.
- Material box, including items such as power cords\*, accessory kit, and printed documents.

#### Notes:

- Some of the items listed are available on select models only.
- Items marked with asterisk(\*) are optional.

If any item is missing or damaged, contact your place of purchase. Ensure that you retain your proof of purchase and packing material. They might be required to receive warranty service.

---

### Identify the server and access the Lenovo XClarity Controller

This section contains instruction on how to identify your server and where to find the Lenovo XClarity Controller access information.

#### Identifying your server

When you contact Lenovo for help, the machine type, model, and serial number information help support technicians to identify your server and provide faster service.

The illustration below shows the location of the ID label which contains the model number, machine type, and serial number of the server.

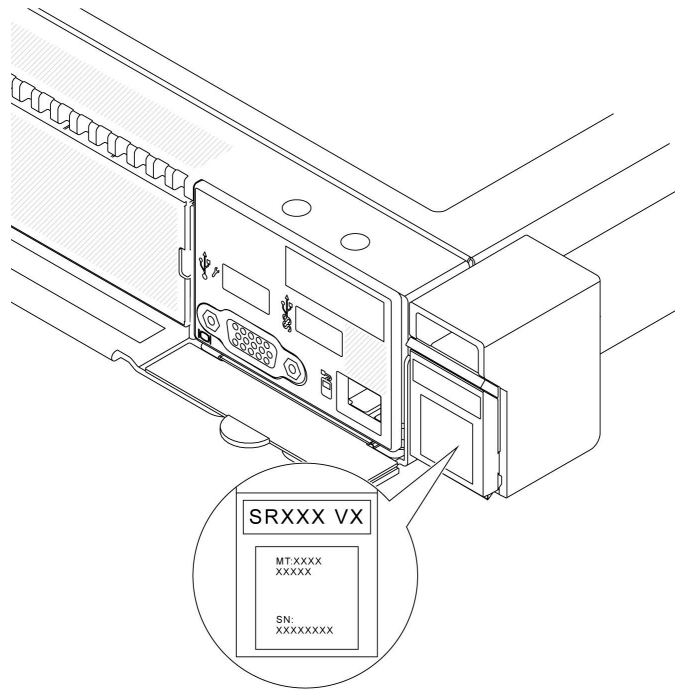

Figure 27. Location of the ID label

### Lenovo XClarity Controller network access label

In addition, the Lenovo XClarity Controller network access label is attached to the pull-out information tab in the front of the chassis, with MAC address accessible with a pull.

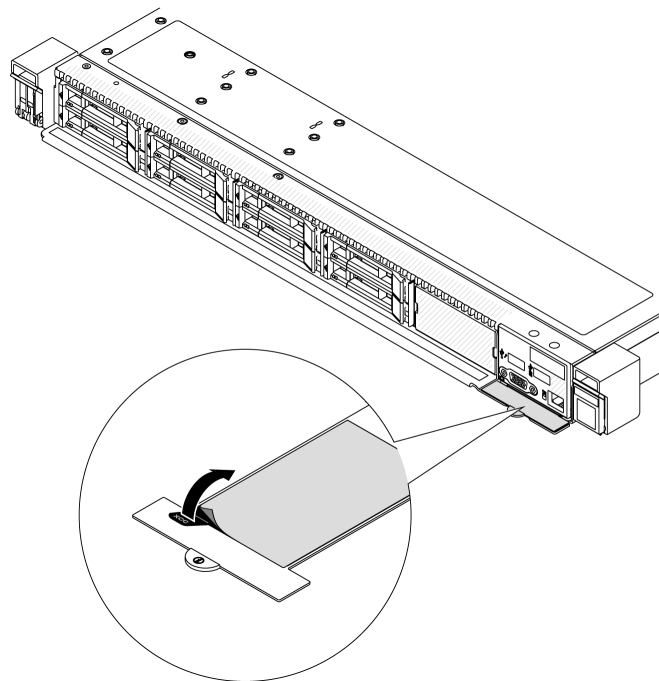

Figure 28. Lenovo XClarity Controller network access label on the pull-out information tab

## Service Label and QR code

In addition, the system Service Label is located on the surface of the top cover, providing a quick response (QR) code for mobile access to service information. You can scan the QR code with a mobile device using a QR code reader application and get quick access to the Service Information web page. The Service Information web page provides additional information for parts installation and replacement videos, and error codes for solution support.

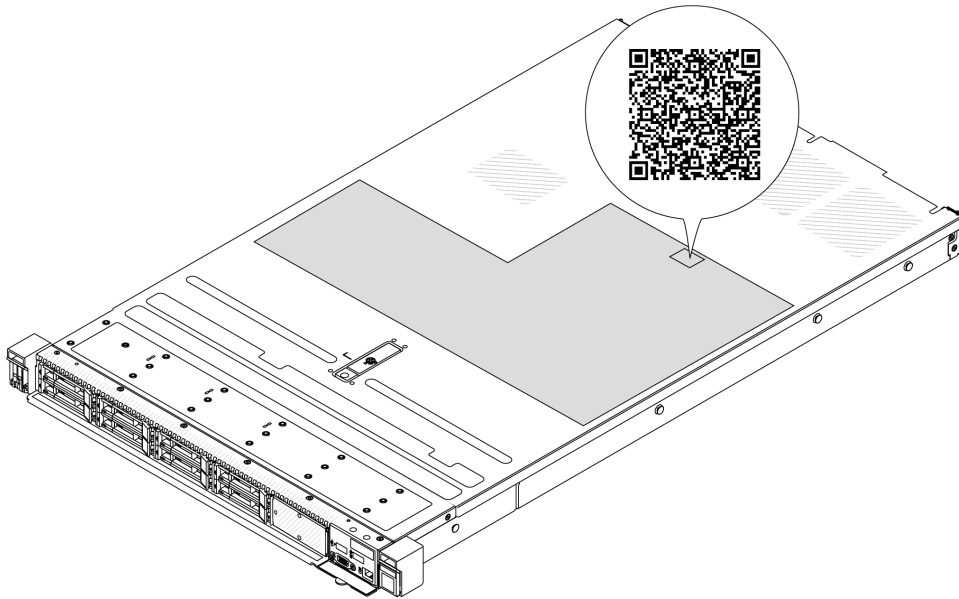

Figure 29. Service Label and QR code

---

## Server setup checklist

Use the server setup checklist to ensure that you have performed all tasks that are required to set up your server.

The server setup procedure varies depending on the configuration of the server when it was delivered. In some cases, the server is fully configured and you just need to connect the server to the network and an AC power source, and then you can power on the server. In other cases, the server needs to have hardware options installed, requires hardware and firmware configuration, and requires an operating system to be installed.

The following steps describe the general procedure for setting up a server.

### Setup the server hardware

Complete the following procedures to setup the server hardware.

1. Unpack the server package. See [“Server package contents” on page 73](#).
2. Install any required hardware or server options. See the related topics in “Hardware replacement procedures” in *User Guide* or *Hardware Maintenance Guide*.
3. If necessary, install the rail and CMA to a standard rack cabinet. Follow the instruction in *Rail Installation Guide* and *CMA Installation Guide* that comes with the rail installation kit.
4. If necessary, install the server into a standard rack cabinet. See “Install the server to rack” in *User Guide* or *Hardware Maintenance Guide*.

5. Connect all external cables to the server. See [Chapter 2 “Server components” on page 23](#) for connectors locations.

Typically, you will need to connect the following cables:

- Connect server to the power source
- Connect server to the data network
- Connect the server to the storage device
- Connect the server to the management network

6. Power on the server.

Power button location and power LED are specified in:

- [Chapter 2 “Server components” on page 23](#)
- “Troubleshooting by system LEDs and diagnostics display” in *User Guide*

The server can be turned on (power LED on) in any of the following ways:

- You can press the power button.
- The server can restart automatically after a power interruption.
- The server can respond to remote power-on requests sent to the Lenovo XClarity Controller.

**Note:** You can access the management processor interface to configure the system without powering on the server. Whenever the server is connected to power, the management processor interface is available. For details about accessing the management server processor, see “Opening and Using the XClarity Controller Web Interface” section in the XCC documentation compatible with your server at <https://pubs.lenovo.com/lxccc-overview/>.

7. Validate the server. Make sure that the power LED, Ethernet connector LED, and network LED are lit with green light, which means the server hardware was set up successfully.

See [“System LEDs and diagnostics display” on page 46](#) for more information on the LED indications.

## Configure the system

Complete the following procedures to configure the system. For detailed instructions, refer to [Chapter 5 “System configuration” on page 77](#).

1. Set the network connection for the Lenovo XClarity Controller to the management network.
2. Update the firmware for the server, if necessary.
3. Configure the firmware for the server.

The following information is available for RAID configuration:

- <https://lenovopress.lenovo.com/lp0578-lenovo-raid-introduction>
- <https://lenovopress.lenovo.com/lp0579-lenovo-raid-management-tools-and-resources>

4. Install the operating system.
5. Back up the server configuration.
6. Install the applications and programs that the server intends to use.

---

## Chapter 5. System configuration

Complete these procedures to configure your system.

---

### Set the network connection for the Lenovo XClarity Controller

Before you can access the Lenovo XClarity Controller over your network, you need to specify how Lenovo XClarity Controller will connect to the network. Depending on how the network connection is implemented, you might need to specify a static IP address as well.

The following methods are available to set the network connection for the Lenovo XClarity Controller if you are not using DHCP:

- If a monitor is attached to the server, you can use Lenovo XClarity Provisioning Manager to set the network connection.

Complete the following steps to connect the Lenovo XClarity Controller to the network using the Lenovo XClarity Provisioning Manager.

1. Start the server.
2. Press the key specified in the on-screen instructions to display the Lenovo XClarity Provisioning Manager interface. (For more information, see the “Startup” section in the LXPM documentation compatible with your server at <https://pubs.lenovo.com/lxpm-overview/>.)
3. Go to **LXPM → UEFI Setup → BMC Settings** to specify how the Lenovo XClarity Controller will connect to the network.
  - If you choose a static IP connection, make sure that you specify an IPv4 or IPv6 address that is available on the network.
  - If you choose a DHCP connection, make sure that the MAC address for the server has been configured in the DHCP server.
4. Click **OK** to apply the setting and wait for two to three minutes.
5. Use an IPv4 or IPv6 address to connect Lenovo XClarity Controller.

**Important:** The Lenovo XClarity Controller is set initially with a user name of USERID and password of PASSW0RD (with a zero, not the letter O). This default user setting has Supervisor access. It is required to change this user name and password during your initial configuration for enhanced security.

- If no monitor is attached to the server, you can set the network connection through the Lenovo XClarity Controller interface. Connect an Ethernet cable from your laptop to XCC system management port on your server. For the location of the XCC system management port, see [Chapter 2 “Server components” on page 23](#).

**Note:** Make sure that you modify the IP settings on the laptop so that it is on the same network as the server default settings.

The default IPv4 address and the IPv6 Link Local Address (LLA) is provided on the Lenovo XClarity Controller Network Access label that is affixed to the Pull Out Information Tab. See [“Identify the server and access the Lenovo XClarity Controller” on page 73](#).

- If you are using the Lenovo XClarity Administrator Mobile app from a mobile device, you can connect to the Lenovo XClarity Controller through the Lenovo XClarity Controller USB connector on the server. For the location of the Lenovo XClarity Controller USB connector, see [Chapter 2 “Server components” on page 23](#).

**Note:** The Lenovo XClarity Controller USB connector mode must be set to manage the Lenovo XClarity Controller (instead of normal USB mode). To switch from normal mode to Lenovo XClarity Controller management mode, hold the ID button on the server for at least 3 seconds until its LED flashes slowly (once every couple of seconds). See [Chapter 2 “Server components” on page 23](#) for the location of the ID button.

To connect using the Lenovo XClarity Administrator Mobile app:

1. Connect the USB cable of your mobile device to the Lenovo XClarity Controller USB connector on the server.
2. On your mobile device, enable USB tethering.
3. On your mobile device, launch the Lenovo XClarity Administrator mobile app.
4. If automatic discovery is disabled, click **Discovery** on the USB Discovery page to connect to the Lenovo XClarity Controller.

For more information about using the Lenovo XClarity Administrator Mobile app, see:

[https://pubs.lenovo.com/lxca/lxca\\_usemobileapp](https://pubs.lenovo.com/lxca/lxca_usemobileapp)

---

## Set USB port for Lenovo XClarity Controller connection

Before you can access the Lenovo XClarity Controller through the USB port, you need to configure the USB port for Lenovo XClarity Controller connection.

### Server support

To see if your server supports accessing Lenovo XClarity Controller through the USB port, check one of the following:

- Refer to [Chapter 2 “Server components” on page 23](#).



- If there is a wrench icon on the USB port of your server, you can set the management USB port to connect to Lenovo XClarity Controller. It is also the only USB port that supports USB automation update of the system I/O board (or firmware and RoT security module).

### Setting the USB port for Lenovo XClarity Controller connection

You can switch the USB port between normal and Lenovo XClarity Controller management operation by performing one of the following steps.

- Hold the ID button for at least 3 seconds until its LED flashes slowly (once every couple of seconds). See [Chapter 2 “Server components” on page 23](#) for ID button location.
- From the Lenovo XClarity Controller management controller CLI, run the `usbfp` command. For information about using the Lenovo XClarity Controller CLI, see the “Command-line interface” section in the XCC documentation compatible with your server at <https://pubs.lenovo.com/lxcc-overview/>.
- From the Lenovo XClarity Controller management controller web interface, click **BMC Configuration → Network → USB Management Port Assignment**. For information about Lenovo XClarity Controller web interface functions, see the “Description of XClarity Controller functions on web interface” section in the XCC documentation compatible with your server at <https://pubs.lenovo.com/lxcc-overview/>.

### Checking USB port current setting

You can also check the current setting of the USB port using the Lenovo XClarity Controller management controller CLI (`usbfp` command) or the Lenovo XClarity Controller management controller web interface (**BMC Configuration → Network → USB Management Port Assignment**). See the “Command-line

interface” and “Description of XClarity Controller functions on web interface” sections in the XCC documentation compatible with your server at <https://pubs.lenovo.com/lxcc-overview/>.

---

## Update the firmware

Several options are available to update the firmware for the server.

You can use the tools listed here to update the most current firmware for your server and the devices that are installed in the server.

- Best practices related to updating firmware is available at the following site:
  - <https://lenovopress.lenovo.com/lp0656-lenovo-thinksystem-firmware-and-driver-update-best-practices>
- The latest firmware can be found at the following site:
  - <https://datacentersupport.lenovo.com/products/servers/thinksystem/sr630v3/7d72/downloads/driver-list/>
- You can subscribe to product notification to stay up to date on firmware updates:
  - <https://datacentersupport.lenovo.com/solutions/ht509500>

### Update Bundles (Service Packs)

Lenovo typically releases firmware in bundles called Update Bundles (Service Packs). To ensure that all of the firmware updates are compatible, you should update all firmware at the same time. If you are updating firmware for both the Lenovo XClarity Controller and UEFI, update the firmware for Lenovo XClarity Controller first.

### Update method terminology

- **In-band update.** The installation or update is performed using a tool or application within an operating system that is executing on the server’s core CPU.
- **Out-of-band update.** The installation or update is performed by the Lenovo XClarity Controller collecting the update and then directing the update to the target subsystem or device. Out-of-band updates have no dependency on an operating system executing on the core CPU. However, most out-of-band operations do require the server to be in the S0 (Working) power state.
- **On-Target update.** The installation or update is initiated from an installed operating system executing on the target server itself.
- **Off-Target update.** The installation or update is initiated from a computing device interacting directly with the server’s Lenovo XClarity Controller.
- **Update Bundles (Service Packs).** Update Bundles (Service Packs) are bundled updates designed and tested to provide the interdependent level of functionality, performance, and compatibility. Update Bundles (Service Packs) are server machine-type specific and are built (with firmware and device driver updates) to support specific Windows Server, Red Hat Enterprise Linux (RHEL) and SUSE Linux Enterprise Server (SLES) operating system distributions. Machine-type-specific firmware-only Update Bundles (Service Packs) are also available.

### Firmware updating tools

See the following table to determine the best Lenovo tool to use for installing and setting up the firmware:

Tool	Update Methods Supported	Core System Firmware Updates	I/O Devices Firmware Updates	Drive Firmware Updates	Graphical user interface	Command line interface	Supports Update Bundles (Service Packs)
<b>Lenovo XClarity Provisioning Manager (LXPM)</b>	In-band <sup>2</sup> On-Target	√			√		
<b>Lenovo XClarity Controller (XCC)</b>	In-band <sup>4</sup> Out-of-band Off-Target	√	Selected I/O devices	√ <sup>3</sup>	√		√
<b>Lenovo XClarity Essentials OneCLI (OneCLI)</b>	In-band Out-of-band On-Target Off-Target	√	All I/O devices	√ <sup>3</sup>		√	√
<b>Lenovo XClarity Essentials UpdateXpress (LXCE)</b>	In-band Out-of-band On-Target Off-Target	√	All I/O devices		√		√
<b>Lenovo XClarity Essentials Bootable Media Creator (BoMC)</b>	In-band Out-of-band Off-Target	√	All I/O devices		√ (BoMC application)	√ (BoMC application)	√
<b>Lenovo XClarity Administrator (LXCA)</b>	In-band <sup>1</sup> Out-of-band <sup>2</sup> Off-Target	√	All I/O devices		√		√
<b>Lenovo XClarity Integrator (LXCI) for VMware vCenter</b>	Out-of-band Off-Target	√	Selected I/O devices		√		
<b>Lenovo XClarity Integrator (LXCI) for Microsoft Windows Admin Center</b>	In-band Out-of-band On-Target Off-Target	√	All I/O devices		√		√

Tool	Update Methods Supported	Core System Firmware Updates	I/O Devices Firmware Updates	Drive Firmware Updates	Graphical user interface	Command line interface	Supports Update Bundles (Service Packs)
<b>Lenovo XClarity Integrator (LXCI) for Microsoft System Center Configuration Manager</b>	In-band On-Target	√	All I/O devices		√		√
<b>Notes:</b> <ol style="list-style-type: none"> <li>For I/O firmware updates.</li> <li>For BMC and UEFI firmware updates.</li> <li>Drive firmware update is only supported by the tools and methods below: <ul style="list-style-type: none"> <li>XCC Bare Metal Update (BMU): In-band, and requires system reboot.</li> <li>Lenovo XClarity Essentials OneCLI: <ul style="list-style-type: none"> <li>For OneCLI version earlier than 5.0.0: <ul style="list-style-type: none"> <li>For drives supported by ThinkSystem V2 and V3 products (legacy drives): In-band, and does not require system reboot.</li> <li>For drives supported only by ThinkSystem V3 products (new drives): Staging to XCC and complete the update with XCC BMU (In-band, and requires system reboot.).</li> </ul> </li> <li>For OneCLI 5.0.0 and later versions: In-band, and does not require system reboot.</li> </ul> </li> </ul> </li> <li>Bare Metal Update (BMU) only.</li> </ol>							

- **Lenovo XClarity Provisioning Manager**

From Lenovo XClarity Provisioning Manager, you can update the Lenovo XClarity Controller firmware, the UEFI firmware, and the Lenovo XClarity Provisioning Manager software.

**Note:** By default, the Lenovo XClarity Provisioning Manager Graphical User Interface is displayed when you start the server and press the key specified in the on-screen instructions. If you have changed that default to be the text-based system setup, you can bring up the Graphical User Interface from the text-based system setup interface.

For additional information about using Lenovo XClarity Provisioning Manager to update firmware, see:

“Firmware Update” section in the LXPM documentation compatible with your server at <https://pubs.lenovo.com/lxpm-overview/>

- **Lenovo XClarity Controller**

If you need to install a specific update, you can use the Lenovo XClarity Controller interface for a specific server.

**Notes:**

- To perform an in-band update through Windows or Linux, the operating system driver must be installed and the Ethernet-over-USB (sometimes called LAN over USB) interface must be enabled.

For additional information about configuring Ethernet over USB, see:

“Configuring Ethernet over USB” section in the XCC documentation version compatible with your server at <https://pubs.lenovo.com/lxcc-overview/>

- If you update firmware through the Lenovo XClarity Controller, make sure that you have downloaded and installed the latest device drivers for the operating system that is running on the server.

For additional information about using Lenovo XClarity Controller to update firmware, see:

“Updating Server Firmware” section in the XCC documentation compatible with your server at <https://pubs.lenovo.com/lxcc-overview/>

- **Lenovo XClarity Essentials OneCLI**

Lenovo XClarity Essentials OneCLI is a collection of command line applications that can be used to manage Lenovo servers. Its update application can be used to update firmware and device drivers for your servers. The update can be performed within the host operating system of the server (in-band) or remotely through the BMC of the server (out-of-band).

For additional information about using Lenovo XClarity Essentials OneCLI to update firmware, see:

[https://pubs.lenovo.com/lxce-onecli/onecli\\_c\\_update](https://pubs.lenovo.com/lxce-onecli/onecli_c_update)

- **Lenovo XClarity Essentials UpdateXpress**

Lenovo XClarity Essentials UpdateXpress provides most of OneCLI update functions through a graphical user interface (GUI). It can be used to acquire and deploy Update Bundles (Service Packs) update packages and individual updates. Update Bundles (Service Packs) contain firmware and device driver updates for Microsoft Windows and for Linux.

You can obtain Lenovo XClarity Essentials UpdateXpress from the following location:

<https://datacentersupport.lenovo.com/solutions/Invo-xpress>

- **Lenovo XClarity Essentials Bootable Media Creator**

You can use Lenovo XClarity Essentials Bootable Media Creator to create bootable media that is suitable for firmware updates, VPD updates, inventory and FFDC collection, advanced system configuration, FoD Keys management, secure erase, RAID configuration, and diagnostics on supported servers.

You can obtain Lenovo XClarity Essentials BoMC from the following location:

<https://datacentersupport.lenovo.com/solutions/Invo-bomc>

- **Lenovo XClarity Administrator**

If you are managing multiple servers using the Lenovo XClarity Administrator, you can update firmware for all managed servers through that interface. Firmware management is simplified by assigning firmware-compliance policies to managed endpoints. When you create and assign a compliance policy to managed endpoints, Lenovo XClarity Administrator monitors changes to the inventory for those endpoints and flags any endpoints that are out of compliance.

For additional information about using Lenovo XClarity Administrator to update firmware, see:

[https://pubs.lenovo.com/lxca/update\\_fw](https://pubs.lenovo.com/lxca/update_fw)

- **Lenovo XClarity Integrator offerings**

Lenovo XClarity Integrator offerings can integrate management features of Lenovo XClarity Administrator and your server with software used in a certain deployment infrastructure, such as VMware vCenter, Microsoft Admin Center, or Microsoft System Center.

For additional information about using Lenovo XClarity Integrator to update firmware, see:

<https://pubs.lenovo.com/lxci-overview/>

---

## Configure the firmware

Several options are available to install and set up the firmware for the server.

**Important:** Lenovo does not recommend setting option ROMs to **Legacy**, but you can conduct this setting if necessary. Note that this setting prevents UEFI drivers for the slot devices from loading, which may cause

negative side effects to Lenovo software, such as LXCA, OneCLI, and XCC. These side effects include but are not limited to the inability to determine adapter card details, such as model name and firmware levels. For example, "ThinkSystem RAID 930-16i 4GB Flash" may be displayed as "Adapter 06:00:00". In some cases, the functionality on a specific PCIe adapter may not be enabled properly.

- **Lenovo XClarity Provisioning Manager (LXPM)**

From Lenovo XClarity Provisioning Manager, you can configure the UEFI settings for your server.

**Notes:** The Lenovo XClarity Provisioning Manager provides a Graphical User Interface to configure a server. The text-based interface to system configuration (the Setup Utility) is also available. From Lenovo XClarity Provisioning Manager, you can choose to restart the server and access the text-based interface. In addition, you can choose to make the text-based interface the default interface that is displayed when you start LXPM. To do this, go to **Lenovo XClarity Provisioning Manager → UEFI Setup → System Settings → <F1>Start Control → Text Setup**. To start the server with Graphic User Interface, select **Auto** or **Tool Suite**.

See the following documentations for more information:

- Search for the LXPM documentation version compatible with your server at <https://pubs.lenovo.com/lxpm-overview/>
- *UEFI User Guide* at <https://pubs.lenovo.com/uefi-overview/>

- **Lenovo XClarity Essentials OneCLI**

You can use the config application and commands to view the current system configuration settings and make changes to Lenovo XClarity Controller and UEFI. The saved configuration information can be used to replicate or restore other systems.

For information about configuring the server using Lenovo XClarity Essentials OneCLI, see:

[https://pubs.lenovo.com/lxce-onecli/onecli\\_c\\_settings\\_info\\_commands](https://pubs.lenovo.com/lxce-onecli/onecli_c_settings_info_commands)

- **Lenovo XClarity Administrator**

You can quickly provision and pre-provision all of your servers using a consistent configuration. Configuration settings (such as local storage, I/O adapters, boot settings, firmware, ports, and Lenovo XClarity Controller and UEFI settings) are saved as a server pattern that can be applied to one or more managed servers. When the server patterns are updated, the changes are automatically deployed to the applied servers.

Specific details about updating firmware using Lenovo XClarity Administrator are available at:

[https://pubs.lenovo.com/lxca/server\\_configuring](https://pubs.lenovo.com/lxca/server_configuring)

- **Lenovo XClarity Controller**

You can configure the management processor for the server through the Lenovo XClarity Controller Web interface, the command-line interface, or Redfish API.

For information about configuring the server using Lenovo XClarity Controller, see:

“Configuring the Server” section in the XCC documentation compatible with your server at <https://pubs.lenovo.com/lxcc-overview/>

---

## Enable Software Guard Extensions (SGX)

Intel® Software Guard Extensions (Intel® SGX) operates under the assumption that the security perimeter includes only the internals of the CPU package, and leaves the DRAM untrusted.

Complete the following steps to enable SGX.

- Step 1. **Make sure** to refer to “Memory module installation rules and order” section in the *User Guide* or *Hardware Maintenance Guide*, which specifies whether your server supports SGX and lists the memory module population sequence for SGX configuration. (DIMM configuration must be at least 8 DIMMs per socket to support SGX.)
- Step 2. Restart the system. Before the operating system starts up, press the key specified in the on-screen instructions to enter the Setup Utility. (For more information, see the “Startup” section in the LXPM documentation compatible with your server at <https://pubs.lenovo.com/lxpm-overview/>.)
- Step 3. Go to **System settings** → **Processors** → **UMA-Based Clustering** and disable the option.
- Step 4. Go to **System settings** → **Processors** → **Total Memory Encryption (TME)** and enable the option.
- Step 5. Save the changes, then go to **System settings** → **Processors** → **SW Guard Extension (SGX)** and enable the option.

---

## RAID configuration

Using a Redundant Array of Independent Disks (RAID) to store data remains one of the most common and cost-efficient methods to increase server's storage performance, availability, and capacity.

RAID increases performance by allowing multiple drives to process I/O requests simultaneously. RAID can also prevent data loss in case of a drive failure by reconstructing (or rebuilding) the missing data from the failed drive using the data from the remaining drives.

RAID array (also known as RAID drive group) is a group of multiple physical drives that uses a certain common method to distribute data across the drives. A virtual drive (also known as virtual disk or logical drive) is a partition in the drive group that is made up of contiguous data segments on the drives. Virtual drive is presented up to the host operating system as a physical disk that can be partitioned to create OS logical drives or volumes.

An introduction to RAID is available at the following Lenovo Press website:

<https://lenovopress.lenovo.com/lp0578-lenovo-raid-introduction>

Detailed information about RAID management tools and resources is available at the following Lenovo Press website:

<https://lenovopress.lenovo.com/lp0579-lenovo-raid-management-tools-and-resources>

## Intel VROC

### Enabling Intel VROC

Before setting up RAID for NVMe drives, follow the below steps to enable VROC:

1. Restart the system. Before the operating system starts up, press the key specified in the on-screen instructions to enter the Setup Utility. (For more information, see the “Startup” section in the LXPM documentation compatible with your server at <https://pubs.lenovo.com/lxpm-overview/>.)
2. Go to **System settings** → **Devices and I/O Ports** → **Intel® VMD technology** → **Enable/Disable Intel® VMD** and enable the option.
3. Save the changes and reboot the system.

### Intel VROC configurations

Intel offers various VROC configurations with different RAID level and SSD support. See the following for more details.

**Notes:**

- Supported RAID levels varies by model. For the RAID level supported by SR630 V3, see [Technical specifications](#).
- For more information about acquiring and installing the activation key, see <https://fod.lenovo.com/lkms>.

Intel VROC configurations for PCIe NVMe SSDs	Requirements
Intel VROC Standard	<ul style="list-style-type: none"> <li>• Supports RAID levels 0, 1, and 10</li> <li>• Requires an activation key</li> </ul>
Intel VROC Premium	<ul style="list-style-type: none"> <li>• Supports RAID levels 0, 1, 5, and 10</li> <li>• Requires an activation key</li> </ul>
Bootable RAID	<ul style="list-style-type: none"> <li>• RAID 1 only</li> <li>• Supported by 5th Gen Intel® Xeon® Scalable processors (formerly codenamed as Emerald Rapids, EMR)</li> <li>• Requires an activation key</li> </ul>
Intel VROC configurations for SATA SSDs	Requirements
Intel VROC SATA RAID	<ul style="list-style-type: none"> <li>• Supports RAID levels 0, 1, 5, and 10.</li> </ul>

---

## Deploy the operating system

Several options are available to deploy an operating system on the server.

### Available operating systems

- Microsoft Windows Server
- VMware ESXi
- Red Hat Enterprise Linux
- SUSE Linux Enterprise Server
- Canonical Ubuntu

Complete list of available operating systems: <https://lenovopress.lenovo.com/osig>.

### Tool-based deployment

- **Multi-server**

Available tools:

- Lenovo XClarity Administrator  
[https://pubs.lenovo.com/lxca/compute\\_node\\_image\\_deployment](https://pubs.lenovo.com/lxca/compute_node_image_deployment)
- Lenovo XClarity Essentials OneCLI  
[https://pubs.lenovo.com/lxce-onecli/onecli\\_r\\_uxspi\\_proxy\\_tool](https://pubs.lenovo.com/lxce-onecli/onecli_r_uxspi_proxy_tool)
- Lenovo XClarity Integrator deployment pack for SCCM (for Windows operating system only)  
[https://sysmgmt.lenovofiles.com/help/topic/com.lenovo.lxci\\_deploypack\\_sccm.doc/dpsccm\\_c\\_endtoend\\_deploy\\_scenario.html](https://sysmgmt.lenovofiles.com/help/topic/com.lenovo.lxci_deploypack_sccm.doc/dpsccm_c_endtoend_deploy_scenario.html)

- **Single-server**

Available tools:

- Lenovo XClarity Provisioning Manager

“OS Installation” section in the LXPM documentation compatible with your server at <https://pubs.lenovo.com/lxpm-overview/>

- Lenovo XClarity Essentials OneCLI

[https://pubs.lenovo.com/lxce-onecli/onecli\\_r\\_uxspi\\_proxy\\_tool](https://pubs.lenovo.com/lxce-onecli/onecli_r_uxspi_proxy_tool)

- Lenovo XClarity Integrator deployment pack for SCCM (for Windows operating system only)

[https://sysmgmt.lenovofiles.com/help/topic/com.lenovo.lxci\\_deploypack\\_sccm.doc/dpsccm\\_c\\_endtoend\\_deploy\\_scenario.html](https://sysmgmt.lenovofiles.com/help/topic/com.lenovo.lxci_deploypack_sccm.doc/dpsccm_c_endtoend_deploy_scenario.html)

## Manual deployment

If you cannot access the above tools, follow the instructions below, download the corresponding OS *Installation Guide*, and deploy the operating system manually by referring to the guide.

1. Go to <https://datacentersupport.lenovo.com/solutions/server-os>.
2. Select an operating system from the navigation pane and click **Resources**.
3. Locate the “OS Install Guides” area and click the installation instructions. Then, follow the instructions to complete the operation system deployment task.

---

## Back up the server configuration

After setting up the server or making changes to the configuration, it is a good practice to make a complete backup of the server configuration.

Make sure that you create backups for the following server components:

- **Management processor**

You can back up the management processor configuration through the Lenovo XClarity Controller interface. For details about backing up the management processor configuration, see:

“Backing up the BMC configuration” section in the XCC documentation compatible with your server at <https://pubs.lenovo.com/lxcc-overview/>.

Alternatively, you can use the `save` command from Lenovo XClarity Essentials OneCLI to create a backup of all configuration settings. For more information about the `save` command, see:

[https://pubs.lenovo.com/lxce-onecli/onecli\\_r\\_save\\_command](https://pubs.lenovo.com/lxce-onecli/onecli_r_save_command)

- **Operating system**

Use your backup methods to back up the operating system and user data for the server.

---

## Enable Intel® On Demand

A processor is equipped with various computing capabilities. Basic capabilities are available at the initial processor installation, while others remain inactivated. As development environment and tasks evolve, computing demands may accelerate and require leverage of the previously inactivated processor capabilities. In such cases, user can select desired processor capabilities and activate them through Intel On Demand feature—a feature that allows user to customize processor capabilities according to environment and tasks at hand. The following section specifies system hardware and software requirement, Intel On Demand enabling and transferring procedures, and list of processor capabilities.

This documentation includes the following sections:

- “Supported processor” on page 87
- “Installation tool” on page 87
- Procedures for “Enabling Intel On Demand Features” on page 88
- Procedures for “Transferring Intel On Demand Features” on page 88

- XCC and LXCE OneCLI instructions for:
  - “Reading PPIN” on page 89
  - “Installing Intel On Demand to processor” on page 90
  - “Acquiring and uploading Intel On Demand State Report” on page 91
  - “Checking the Intel On Demand features installed in a processor” on page 93

**Note:** Depending on the model, the XCC Web GUI layout may be slightly different from the illustrations in this document.

### Supported processor

Intel On Demand is only supported by Intel On Demand capable processors. For more information on Intel On Demand capable processors supported by SR630 V3, see <https://lenovopress.lenovo.com/lp1600-thinksystem-sr630-v3-server>.

**Note:** All processors in a system must be installed with identical Intel On Demand feature.

### Installation tool

Intel On Demand can be installed via Lenovo XClarity Controller (XCC) and Lenovo XClarity Essentials OneCLI (LXCE OneCLI). After confirming that your processor supports Intel On Demand, you also need to make sure the XCC and LXCE OneCLI installed in your system supports installing Intel On Demand.

1. Check if Lenovo XClarity Controller (XCC) supports installing Intel On Demand (two methods provided):

- **Via XCC WebGUI**

Go to **BMC Configuration** → **License**, if there is a section named **On Demand Capabilities for Intel CPU** in the page, it indicates that current XCC supports installing Intel On Demand, otherwise you need to update XCC firmware to the latest version to ensure it supports installing Intel On Demand.

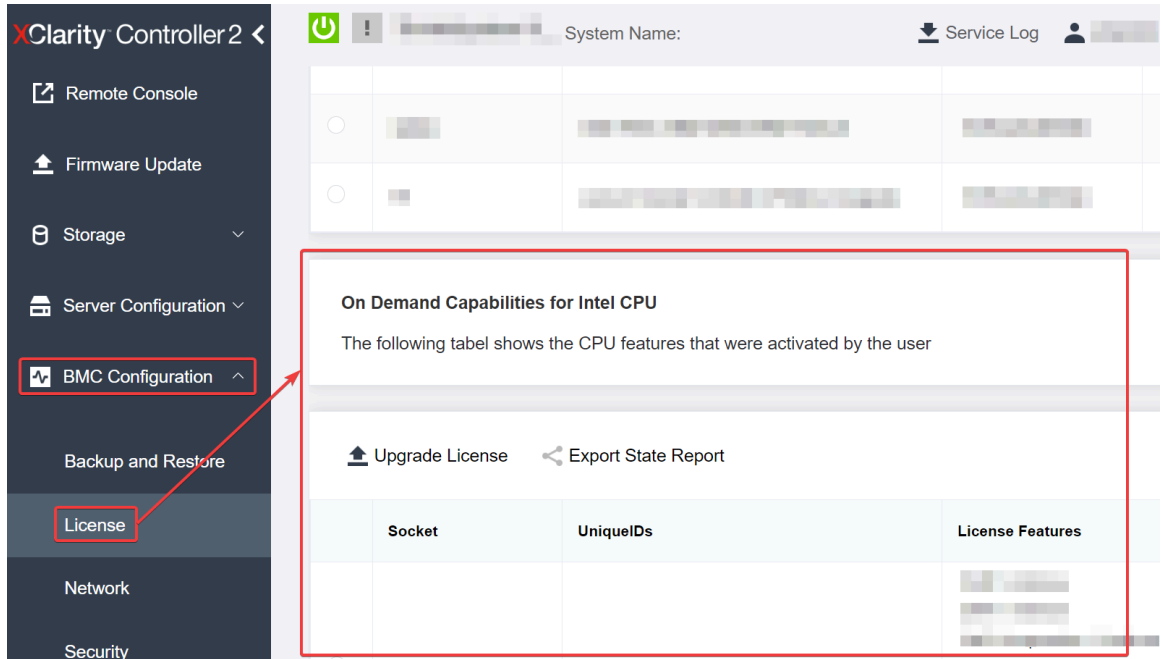

Figure 30. On Demand Capabilities for Intel CPU in XCC Web GUI

- **Via XCC REST API**

- a. Use the **GET** method with the following Request URL:  
GET [https://bmc\\_ip/redfish/v1/LicenseService/Licenses/](https://bmc_ip/redfish/v1/LicenseService/Licenses/)

- b. In the response JSON object, the Members field includes the API such as `/redfish/v1/LicenseService/Licenses/CPUX_OnDemandCapability`, where X is the CPU numbering, it indicates that current XCC supports installing Intel On Demand, otherwise you need to update XCC firmware to the latest version to ensure it supports installing Intel On Demand.

For example:

```
"Members": [  
  {  
    "@odata.id": "/redfish/v1/LicenseService/Licenses/CPU1_OnDemandCapability"  
  },  
  {  
    "@odata.id": "/redfish/v1/LicenseService/Licenses/CPU2_OnDemandCapability"  
  },  
]
```

2. Check if LXCE OneCLI supports installing Intel On Demand
  - LXCE OneCLI version must be at 4.2.0 or above.

### Enabling Intel On Demand Features

1. Select the Intel On Demand features that meets your workload needs, see [“Intel On Demand Features” on page 95](#).
2. After completing ordering the features, you will receive Authorization Code via e-mail.
3. PPIN is a mandatory information for enabling the features. Read the PPIN of the processor that is to be installed with the features. See [“Reading PPIN” on page 89](#).
4. Go to <https://fod.lenovo.com/lkms> and input the Authorization Code to acquire the Activation Key.
5. In the website, input Machine Type, Machine serial number, and PPIN.
6. The website will generate the Activation Key. Download the Activation Key.
7. Install the features to the processor with the Activation Key via XCC or LXCE OneCLI. See [“Installing Intel On Demand to processor” on page 90](#).

**Note:** If more than one Activation Keys are acquired, it is mandatory to install them in the sequential order they were acquired. For example, start with installing the first acquired key, and proceed with the second acquired key, and so on.

8. AC cycle the server.
9. (Optional) Upload Intel On Demand State Report. See [“Acquiring and uploading Intel On Demand State Report” on page 91](#).

The State Report represents the current configuration state of the Intel On Demand capable processors. Lenovo accepts State Reports from customers to calibrate the current state of the Intel On Demand capable processors.

10. To see the features installed in a processor, see [“Checking the Intel On Demand features installed in a processor” on page 93](#).

For reference, see [https://pubs.lenovo.com/lenovo\\_fod](https://pubs.lenovo.com/lenovo_fod).

### Transferring Intel On Demand Features

After replacing a processor, you may need to transfer the features from the defective processor to the new processor. Complete the following steps to transfer features to new processor.

1. Before removing the defective processor from the system, read the PPIN of the defective processor. See [“Reading PPIN” on page 89](#).
2. After installing the new processor, read the PPIN of the new processor. See [“Reading PPIN” on page 89](#).

- Go to <https://fod.lenovo.com/lkms> and input the PPIN of the defective processor. (Input PPIN in the UID section.)
- Select the features to be transferred.
- Input the PPIN of the new processor.
- The website will generate the new Activation Key. Download the new Activation Key. See “[Installing Intel On Demand to processor](#)” on page 90.
- Install the features to the new processor with the new Activation Key via XCC or LXCE OneCLI.
- AC cycle the server.
- (Optional) Upload Intel On Demand State Report. See “[Acquiring and uploading Intel On Demand State Report](#)” on page 91.

The State Report represents the current configuration state of the Intel On Demand capable processors. Lenovo accepts State Reports from customers to calibrate the current state of the Intel On Demand capable processors.

- To see the features installed in a processor, see “[Checking the Intel On Demand features installed in a processor](#)” on page 93.

For reference, see [https://pubs.lenovo.com/lenovo\\_fod](https://pubs.lenovo.com/lenovo_fod).

## Reading PPIN

Protected Processor Inventory Number, or PPIN, is a mandatory information for enabling Intel On Demand. PPIN can be read via XCC Web GUI, XCC REST API, and LXCE OneCLI. See the following for more information.

### Reading PPIN via XCC Web GUI

Open XCC Web GUI, go to **Inventory page → CPU tab → Expand → PPIN**

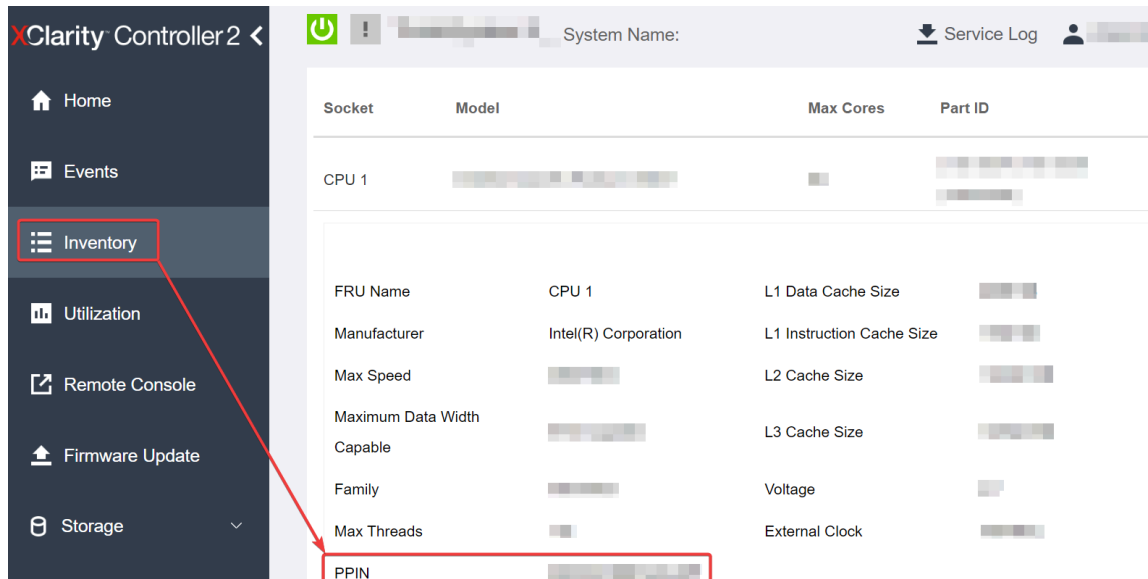

Figure 31. Reading PPIN via XCC Web GUI

### Reading PPIN via XCC REST API

- Use the **GET** method with the following Request URL:  
GET [https://bmc\\_ip/redfish/v1/Systems/1/Processors](https://bmc_ip/redfish/v1/Systems/1/Processors)

For example:

```
GET https://bmc_ip/redfish/v1/Systems/1/Processors
```

2. In the response JSON object, the Members field shows reference link to an element of processor resource.

For example:

```
"Members":[
{
@odata.id: "/redfish/v1/Systems/1/Processors/1"
},
{
@odata.id: "/redfish/v1/Systems/1/Processors/2"
}
],
```

3. Select the processor you need to read the PPIN from. Use the **GET** method with the following Request URL, where x is the CPU numbering:

```
GET https://bmc_ip/redfish/v1/Systems/1/Processors/x
```

For example, to read Processor 1 PPIN, see the following:

```
GET https://bmc_ip/redfish/v1/Systems/1/Processors/1
```

4. In the response JSON object, the ProcessorId field shows the ProtectedIdentificationNumber field, which is the PPIN info of the requested CPU.

For example:

```
"ProcessorId":{
"ProtectedIdentificationNumber":"1234567890xxxyyy"
},
```

### Reading PPIN via LXCE OneCLI

Input the following command:

```
OneCli.exe fod showppin -b XCC_USER:XCC_PASSWORD@XCC_HOST
```

The output shows PPIN information. For example:

Machine Type: 7D75

Serail Number: 7D75012345

FoD PPIN result:

```
=====
| Socket ID |          PPIN          |
| Processor 1 | 1234567890xxxyyy |
| Processor 2 | 9876543210zzzyyy |
=====
```

### Installing Intel On Demand to processor

Install Intel On Demand features to the processor with the Activation Key downloaded from the <https://fod.lenovo.com/lkms> via XCC Web GUI, XCC REST API or LXCE OneCLI.

### Use XCC Web GUI to install Intel On Demand

1. Open XCC Web GUI, go to **BMC Configuration → License → On Demand Capabilities for Intel CPU → Upgrade License → Browse → Import** to upload the Activation Key

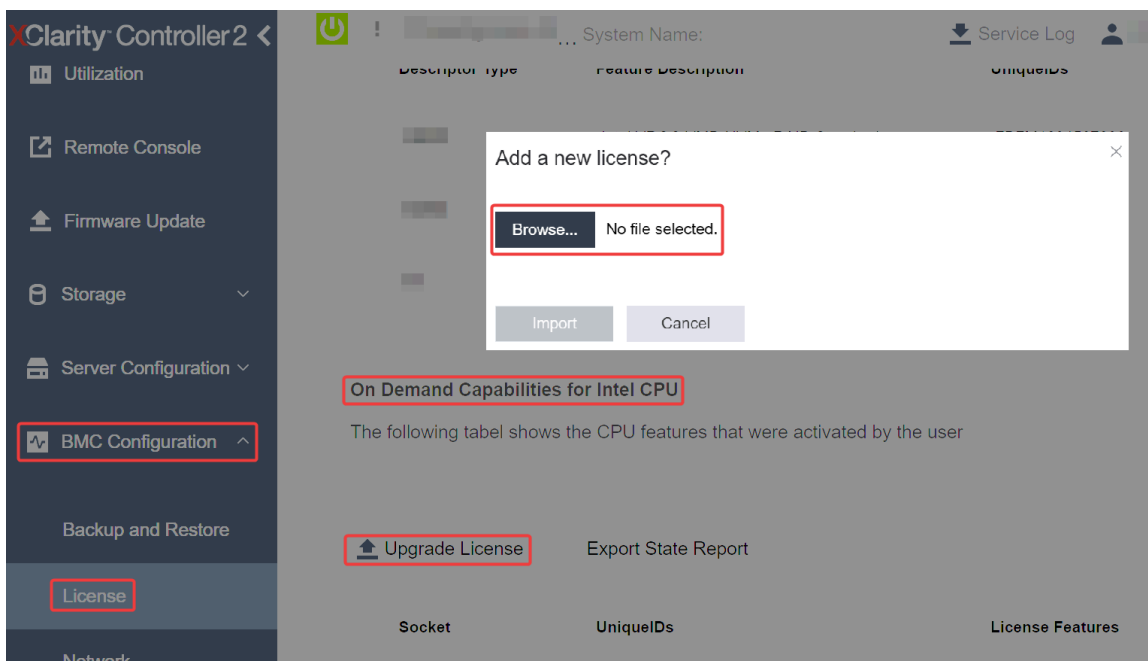

Figure 32. Uploading Activation Key via XCC Web GUI

2. If the installation is successful, the Web GUI will show a pop-up window with the message “License key upgraded successfully. The features will be activated on the processor after system power cycle”.

Otherwise, see [“Enable Intel® On Demand Troubleshooting” on page 96](#).

#### Use XCC REST API to install Intel On Demand

1. Use the **POST** method with the following Request URL:  
POST https://bmc\_ip/redfish/v1/LicenseService/Licenses
2. Transfer Activation Key to base64 string at first and fill it into the LicenseString field as POST data.  

```
{
  "LicenseString": ""
}
```
3. If the installation is successful, XCC REST API show the message “License key upgraded successfully. The features will be activated on the processor after system power cycle”.

Otherwise, see [“Enable Intel® On Demand Troubleshooting” on page 96](#).

#### Use LXCE OneCLI to install Intel On Demand

Input the following command, where <key\_file> specifies the Activation Key:  
OneCli.exe fod install --keyfile <key\_file>

If successfully installed, the response will show:  
Successfully install key

Call Lenovo support if the response shows the following:  
Failed to install key

#### Acquiring and uploading Intel On Demand State Report

After completing enabling or transferring Intel On Demand, acquire and upload the State Report via XCC Web GUI, XCC REST API, and LXCE OneCLI. See the following for more information.

#### Use XCC Web GUI to upload State Report

1. Open XCC Web GUI, go to **BMC Configuration → License → On Demand Capabilities for Intel CPU → Choose CPU → Export State Report**

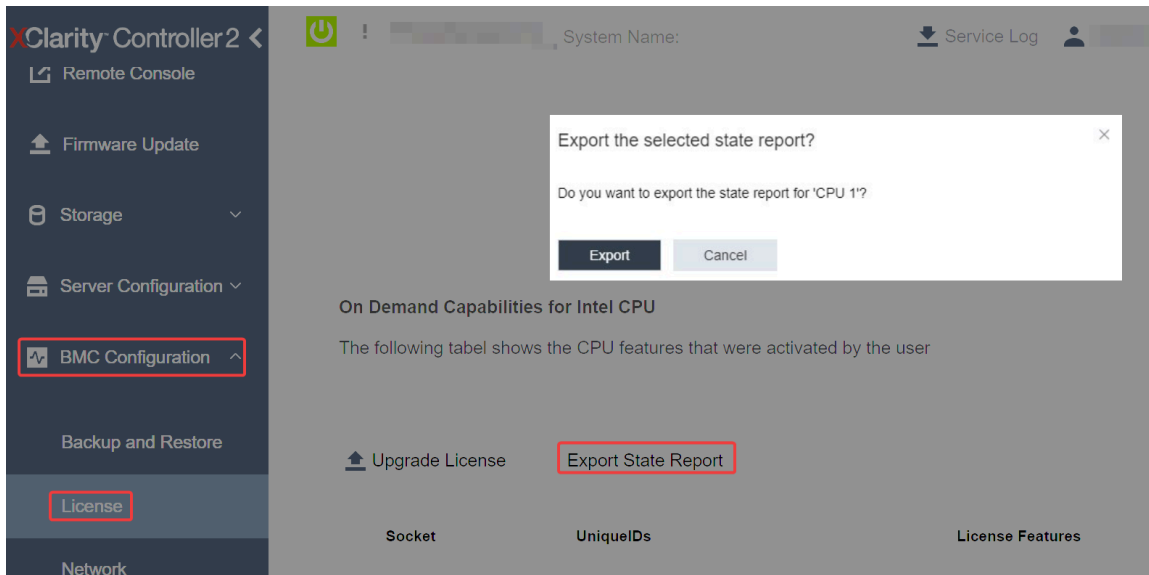

Figure 33. Export State Report via XCC Web GUI

2. Upload State Report via “On Demand Feedback” section in <https://fod.lenovo.com/lkms>.

### Use XCC REST API to upload State Report

1. Use the **GET** method with the following Request URL to retrieve CPU State Report API, where X is the CPU numbering:  
 GET `https://bmc_ip/redfish/v1/LicenseService/Licenses/CPUX_OnDemandCapability`  
 For example, to retrieve CPU 1 State Report API, see the following:  
 GET `https://bmc_ip/redfish/v1/LicenseService/Licenses/CPU1_OnDemandCapability`
2. In the response JSON object, the response of the target field of the `LenovoLicense.ExportStateReport` field is the CPU State Report API, where X is the CPU numbering:

```

"Actions": {
  "Oem": {
    "#LenovoLicense.ExportStateReport": {
      "title": "ExportStateReport",
      "target": "/redfish/v1/LicenseService/Licenses/CPUX_OnDemandCapability/Actions/Oem/LenovoLicense.ExportStateReport"
    }
  }
},

```

In the following example, the response of the target field is the CPU 1 State Report API. Copy the CPU 1 State Report API.

```

"Actions": {
  "Oem": {
    "#LenovoLicense.ExportStateReport": {
      "title": "ExportStateReport",
      "target": "/redfish/v1/LicenseService/Licenses/CPU1_OnDemandCapability/Actions/Oem/LenovoLicense.ExportStateReport"
    }
  }
},

```

3. Retrieve the State Report.
  - a. Use the **POST** method with the following Request URL with CPU State Report API to retrieve the State Report, where X is the CPU numbering:

POST [https://bmc\\_ip/redfish/v1/LicenseService/licenses/CPUX\\_OnDemandCapability/Actions/Oem/LenovoLicense.ExportStateReport](https://bmc_ip/redfish/v1/LicenseService/licenses/CPUX_OnDemandCapability/Actions/Oem/LenovoLicense.ExportStateReport)

For example, to retrieve CPU 1 State Report, see the following:

POST [https://bmc\\_ip/redfish/v1/LicenseService/licenses/CPU1\\_OnDemandCapability/Actions/Oem/LenovoLicense.ExportStateReport](https://bmc_ip/redfish/v1/LicenseService/licenses/CPU1_OnDemandCapability/Actions/Oem/LenovoLicense.ExportStateReport)

- b. Use an empty JSON object as POST data. When using API tool such as Postman, fill an empty JSON object in **Body** → **Raw** → **JSON**, fill a NULL object '{}' in a JSON file.

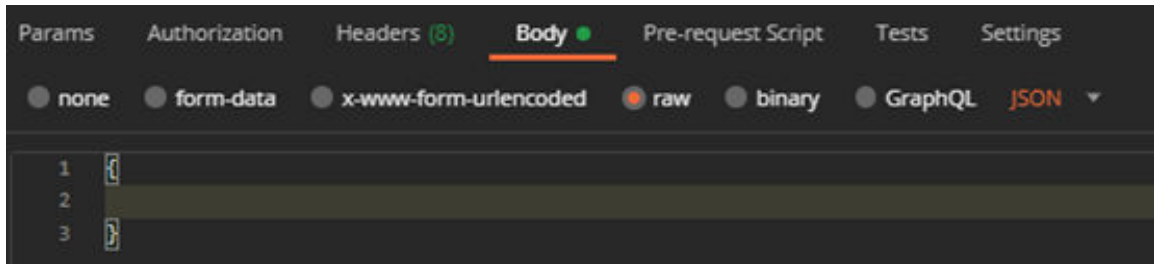

4. In the response, retrieve the State Report in the stateReports field.

```
{
  "stateReports": [
    {
      "syntaxVersion": "1.0",
      "timestamp": "",
      "objectId": "",
      "hardwareComponentData": [
        {
          "hardwareId": {
            "type": "PPIN",
            "value": ""
          },
          "stateCertificate": {
            "pendingCapabilityActivationPayloadCount": ,
            "value": ""
          },
          "hardwareType": "CPU"
        }
      ]
    }
  ]
}
```

5. Upload State Report via “On Demand Feedback” section in <https://fod.lenovo.com/lkms>.

### Use LXCE OneCLI to upload State Report

1. Acquire State Report with the following command:  
`OneCli.exe fod exportreport -b XCC_USER:XCC_PASSWORD@XCC_HOST`
2. Upload State Report with the following command:  
`OneCli.exe fod uploadreport --file CPU1_xxxxxx_StateReport.json --kmsid KMS_USER:KMS_PASSWORD`  
Where:

CPU1\_xxxxxx\_StateReport.json is the file name downloaded from the **fod exportreport** command in Step 1.

KMS\_USER and KMS\_PASSWORD are your ID and password on the <https://fod.lenovo.com/lkms>.

### Checking the Intel On Demand features installed in a processor

You can check the Intel On Demand features installed in a processor via XCC Web GUI, XCC REST API, and LXCE OneCLI. See the following for more information.

**Note:** If the processor has not been installed with any license, it would not appear in the **On Demand Capabilities for Intel CPU** section in XCC Web GUI.

### Use XCC Web GUI to check the Intel On Demand features installed in a processor

Go to **BMC Configuration** → **License** → **On Demand Capabilities for Intel CPU** → **Choose CPU** → **License Features**, where the installed features are listed.

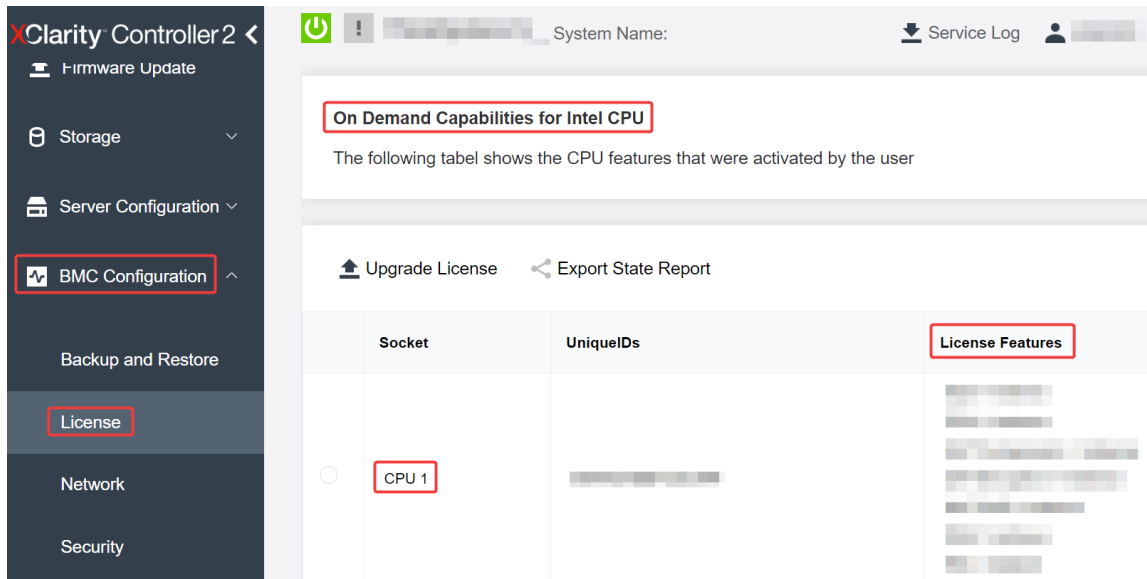

Figure 34. Checking the Intel On Demand features installed in a processor in XCC Web GUI

### Use XCC REST API to check the Intel On Demand features installed in a processor

1. Use the **GET** method with the following Request URL to retrieve Intel On Demand features installed on CPU X, where X is the CPU numbering:  
 GET https://bmc\_ip/redfish/v1/LicenseService/Licenses/CPUX\_OnDemandCapability  
 For example, to retrieve Intel On Demand features installed on CPU 1, see the following:  
 GET https://bmc\_ip/redfish/v1/LicenseService/Licenses/CPU1\_OnDemandCapability
2. In the response JSON object, the FeatureList field contains the Intel On Demand features installed in this processor.

```

{
  "Oem": {
    "Lenovo": {
      "FeatureList": [],
      "@odata.type": ""
    }
  }
},

```

### Use LXCE OneCLI to check the Intel On Demand features installed in a processor

1. Check installed features with the following command:  
 OneCli.exe fod report -b XCC\_USER:XCC\_PASSWORD@XCC\_HOST
2. The output shows all license, including Intel On Demand features. For example:

```

FoD Reports result:
=====
| Feature | Key | Status | Description | User | Expired |
| Type | ID | | Feature List | Reminding | Date |
=====
| N/A | CPU1_OnDemandCapability | StandbyOffline | DSA 4 instances, | N/A | N/A |
| | | | IAA 4 instances | | |
=====
| N/A | CPU2_OnDemandCapability | Enabled | DSA 4 instances, | N/A | N/A |
| | | | IAA 4 instances | | |
=====
| 004a | XCC2_Platinum | Enabled | Lenovo XClarity Controller 2 | N/A | N/A |
| | | | Platinum Upgrade | | |
=====
Succeed.

```

## Intel On Demand Features

Intel On Demand features are listed below. Supported features vary by product, for more information, see <https://lenovopress.lenovo.com/lp1600-thinksystem-sr630-v3-server>.

### Features

- **Intel Quick Assist Technology (Intel QAT)<sup>1</sup>**

Intel® QAT which helps free up processor cores by offloading encryption, decryption, and compression so systems can serve a larger number of clients or use less power. With Intel QAT, 4th gen Intel Xeon Scalable processors are the highest performance CPUs that can compress and encrypt in a single data flow.

- **Intel Dynamic Load Balancer (Intel DLB)<sup>2</sup>**

Intel DLB is a hardware managed system of queues and arbiters connecting producers and consumers. It is a PCI device envisaged to live in the server CPU uncore and can interact with software running on cores, and potentially with other devices.

- **Intel Data Streaming Accelerator (Intel DSA)<sup>1</sup>**

Intel DSA drives high performance for storage, networking, and data-intensive workloads by improving streaming data movement and transformation operations. Designed to offload the most common data movement tasks that cause overhead in data center-scale deployments, Intel DSA helps speed up data movement across the CPU, memory, caches, all attached memory, storage, and network devices.

- **Intel In Memory Accelerator (Intel IAA)<sup>1</sup>**

Intel IAA helps run database and analytics workloads faster, with potentially greater power efficiency. This built-in accelerator increases query throughput and decreases the memory footprint for in-memory database and big data analytics workloads. Intel IAA is ideal for in-memory databases, and source databases.

- **Intel Software Guard Extensions (Intel SGX) 512 GB<sup>3</sup>**

Intel® SGX offers hardware-based memory encryption that isolates specific application code and data in memory. Intel SGX allows user-level code to allocate private regions of memory, called enclaves, which are designed to be protected from processes running at higher privilege levels.

### References

- <sup>1</sup>*Achieve Performance Advantage with Intel oneAPI, AI Tools, and 4th Gen Intel® Xeon® Scalable Processors Featuring Built-in Accelerator Engines*, (n.d.). Intel. <https://www.intel.com/content/www/us/en/developer/articles/technical/performance-advantage-with-xeon-and-oneapi-tools.html>
- <sup>2</sup>*Intel® Dynamic Load Balancer*, (2023, May 23) Intel. <https://www.intel.com/content/www/us/en/download/686372/intel-dynamic-load-balancer.html>

- <sup>3</sup>Intel® Software Guard Extensions (Intel® SGX), (n.d.) Intel. <https://www.intel.com/content/www/us/en/architecture-and-technology/software-guard-extensions.html>

## Enable Intel® On Demand Troubleshooting

Refer to the table below for Intel On Demand installation error messages and user actions.

Table 30. Intel On Demand installation messages and user actions

Message	User Action
License key upgraded successfully. The features will be activated on the processor after system power cycle.	You can activate Intel On Demand after performing one system power cycle.
The activation key format is invalid	Check if you have uploaded the correct Activation Key file. If the error persists, contact Lenovo support.
Invalid processor PPIN in Activation key	Contact Lenovo support.
The license was installed in the processor already	You have already installed this activation key. Check if the activation key you uploaded is correct.
Not enough NMRAM space in the processor	Contact Lenovo support.
Internal error	Contact Lenovo support.
Cold reset needed before next provisioning	If you want to continue installing an activation key, perform a system power cycle at first.
Unable to provision LAC due to FEH error	Contact Lenovo support.
Unable to import license in shutdown state, please try again after power on.	Power on the system before installing Intel On Demand.
Unable to import license due to On Demand Capabilities information is in progress. Please try again later.	If you want to continue installing an activation key, try again later.

---

## Appendix A. Getting help and technical assistance

If you need help, service, or technical assistance or just want more information about Lenovo products, you will find a wide variety of sources available from Lenovo to assist you.

On the World Wide Web, up-to-date information about Lenovo systems, optional devices, services, and support are available at:

<http://datacentersupport.lenovo.com>

**Note:** IBM is Lenovo's preferred service provider for ThinkSystem.

---

### Before you call

Before you call, there are several steps that you can take to try and solve the problem yourself. If you decide that you do need to call for assistance, gather the information that will be needed by the service technician to more quickly resolve your problem.

#### Attempt to resolve the problem yourself

You can solve many problems without outside assistance by following the troubleshooting procedures that Lenovo provides in the online help or in the Lenovo product documentation. The online help also describes the diagnostic tests that you can perform. The documentation for most systems, operating systems, and programs contains troubleshooting procedures and explanations of error messages and error codes. If you suspect a software problem, see the documentation for the operating system or program.

You can find the product documentation for your ThinkSystem products at the following location:

<https://pubs.lenovo.com/>

You can take these steps to try to solve the problem yourself:

- Check all cables to make sure that they are connected.
- Check the power switches to make sure that the system and any optional devices are turned on.
- Check for updated software, firmware, and operating-system device drivers for your Lenovo product. (See the following links) The Lenovo Warranty terms and conditions state that you, the owner of the Lenovo product, are responsible for maintaining and updating all software and firmware for the product (unless it is covered by an additional maintenance contract). Your service technician will request that you upgrade your software and firmware if the problem has a documented solution within a software upgrade.
  - Drivers and software downloads
    - <https://datacentersupport.lenovo.com/products/servers/thinksystem/sr630v3/7d72/downloads/driver-list/>
  - Operating system support center
    - <https://datacentersupport.lenovo.com/solutions/server-os>
  - Operating system installing instructions
    - <https://pubs.lenovo.com/thinksystem#os-installation>
- If you have installed new hardware or software in your environment, check <https://serverproven.lenovo.com> to make sure that the hardware and software are supported by your product.
- Refer to “Problem Determination” in *User Guide* or *Hardware Maintenance Guide* for instructions on isolating and solving issues.

- Go to <http://datacentersupport.lenovo.com> and check for information to help you solve the problem.

To find the Tech Tips available for your server:

1. Go to <http://datacentersupport.lenovo.com>, and input the model name or machine type of your server in the search bar to navigate to the support page.
2. Click on **How To's** from the navigation pane.
3. Click **Article Type** → **Solution** from the drop-down menu.

Follow the on-screen instructions to choose the category for the problem that you are having.

- Check Lenovo Data Center Forum at [https://forums.lenovo.com/t5/Datacenter-Systems/ct-p/sv\\_eg](https://forums.lenovo.com/t5/Datacenter-Systems/ct-p/sv_eg) to see if someone else has encountered a similar problem.

### Gathering information needed to call Support

If you require warranty service for your Lenovo product, the service technicians will be able to assist you more efficiently if you prepare the appropriate information before you call. You can also go to <http://datacentersupport.lenovo.com/warrantylookup> for more information about your product warranty.

Gather the following information to provide to the service technician. This data will help the service technician quickly provide a solution to your problem and ensure that you receive the level of service for which you might have contracted.

- Hardware and Software Maintenance agreement contract numbers, if applicable
- Machine type number (Lenovo 4-digit machine identifier). Machine type number can be found on the ID label, see [“Identify the server and access the Lenovo XClarity Controller” on page 73](#).
- Model number
- Serial number
- Current system UEFI and firmware levels
- Other pertinent information such as error messages and logs

As an alternative to calling Lenovo Support, you can go to <https://support.lenovo.com/servicerequest> to submit an Electronic Service Request. Submitting an Electronic Service Request will start the process of determining a solution to your problem by making the pertinent information available to the service technicians. The Lenovo service technicians can start working on your solution as soon as you have completed and submitted an Electronic Service Request.

---

## Collecting service data

To clearly identify the root cause of a server issue or at the request of Lenovo Support, you might need collect service data that can be used for further analysis. Service data includes information such as event logs and hardware inventory.

Service data can be collected through the following tools:

- **Lenovo XClarity Provisioning Manager**

Use the Collect Service Data function of Lenovo XClarity Provisioning Manager to collect system service data. You can collect existing system log data or run a new diagnostic to collect new data.

- **Lenovo XClarity Controller**

You can use the Lenovo XClarity Controller web interface or the CLI to collect service data for the server. The file can be saved and sent to Lenovo Support.

- For more information about using the web interface to collect service data, see the “Backing up the BMC configuration” section in the XCC documentation compatible with your server at <https://pubs.lenovo.com/lxcc-overview/>.
- For more information about using the CLI to collect service data, see the “XCC `ffdc` command” section in the XCC documentation compatible with your server at <https://pubs.lenovo.com/lxcc-overview/>.

- **Lenovo XClarity Administrator**

Lenovo XClarity Administrator can be set up to collect and send diagnostic files automatically to Lenovo Support when certain serviceable events occur in Lenovo XClarity Administrator and the managed endpoints. You can choose to send diagnostic files to Lenovo Support using Call Home or to another service provider using SFTP. You can also manually collect diagnostic files, open a problem record, and send diagnostic files to the Lenovo Support.

You can find more information about setting up automatic problem notification within the Lenovo XClarity Administrator at [https://pubs.lenovo.com/lxca/admin\\_setupcallhome](https://pubs.lenovo.com/lxca/admin_setupcallhome).

- **Lenovo XClarity Essentials OneCLI**

Lenovo XClarity Essentials OneCLI has inventory application to collect service data. It can run both in-band and out-of-band. When running in-band within the host operating system on the server, OneCLI can collect information about the operating system, such as the operating system event log, in addition to the hardware service data.

To obtain service data, you can run the `getinfor` command. For more information about running the `getinfor`, see [https://pubs.lenovo.com/lxce-onecli/onecli\\_r\\_getinfor\\_command](https://pubs.lenovo.com/lxce-onecli/onecli_r_getinfor_command).

---

## Contacting Support

You can contact Support to obtain help for your issue.

You can receive hardware service through a Lenovo Authorized Service Provider. To locate a service provider authorized by Lenovo to provide warranty service, go to <https://datacentersupport.lenovo.com/serviceprovider> and use filter searching for different countries. For Lenovo support telephone numbers, see <https://datacentersupport.lenovo.com/supportphonenumber> for your region support details.



---

## Appendix B. Documents and supports

This section provides handy documents, driver and firmware downloads, and support resources.

---

### Documents download

This section provides introduction and download link for handy documents.

#### Documents

- **Rail Installation Guides**
  - Rail installation in a rack
- **User Guide**
  - Complete overview, system configuration, hardware components replacing, and troubleshooting.  
Selected chapters from *User Guide*:
    - **System Configuration Guide** : Server overview, components identification, system LEDs and diagnostics display, product unboxing, setting up and configuring the server.
    - **Hardware Maintenance Guide** : Installing hardware components, cable routing, and troubleshooting.
- **Messages and Codes Reference**
  - XClarity Controller, LXPM, and uEFI events
- **UEFI Manual**
  - UEFI setting introduction

---

### Support websites

This section provides driver and firmware downloads and support resources.



---

## Appendix C. Notices

Lenovo may not offer the products, services, or features discussed in this document in all countries. Consult your local Lenovo representative for information on the products and services currently available in your area.

Any reference to a Lenovo product, program, or service is not intended to state or imply that only that Lenovo product, program, or service may be used. Any functionally equivalent product, program, or service that does not infringe any Lenovo intellectual property right may be used instead. However, it is the user's responsibility to evaluate and verify the operation of any other product, program, or service.

Lenovo may have patents or pending patent applications covering subject matter described in this document. The furnishing of this document is not an offer and does not provide a license under any patents or patent applications. You can send inquiries in writing to the following:

*Lenovo (United States), Inc.  
8001 Development Drive  
Morrisville, NC 27560  
U.S.A.  
Attention: Lenovo Director of Licensing*

LENOVO PROVIDES THIS PUBLICATION "AS IS" WITHOUT WARRANTY OF ANY KIND, EITHER EXPRESS OR IMPLIED, INCLUDING, BUT NOT LIMITED TO, THE IMPLIED WARRANTIES OF NON-INFRINGEMENT, MERCHANTABILITY OR FITNESS FOR A PARTICULAR PURPOSE. Some jurisdictions do not allow disclaimer of express or implied warranties in certain transactions, therefore, this statement may not apply to you.

This information could include technical inaccuracies or typographical errors. Changes are periodically made to the information herein; these changes will be incorporated in new editions of the publication. Lenovo may make improvements and/or changes in the product(s) and/or the program(s) described in this publication at any time without notice.

The products described in this document are not intended for use in implantation or other life support applications where malfunction may result in injury or death to persons. The information contained in this document does not affect or change Lenovo product specifications or warranties. Nothing in this document shall operate as an express or implied license or indemnity under the intellectual property rights of Lenovo or third parties. All information contained in this document was obtained in specific environments and is presented as an illustration. The result obtained in other operating environments may vary.

Lenovo may use or distribute any of the information you supply in any way it believes appropriate without incurring any obligation to you.

Any references in this publication to non-Lenovo Web sites are provided for convenience only and do not in any manner serve as an endorsement of those Web sites. The materials at those Web sites are not part of the materials for this Lenovo product, and use of those Web sites is at your own risk.

Any performance data contained herein was determined in a controlled environment. Therefore, the result obtained in other operating environments may vary significantly. Some measurements may have been made on development-level systems and there is no guarantee that these measurements will be the same on generally available systems. Furthermore, some measurements may have been estimated through extrapolation. Actual results may vary. Users of this document should verify the applicable data for their specific environment.

---

## Trademarks

LENOVO and THINKSYSTEM are trademarks of Lenovo.

All other trademarks are the property of their respective owners.

---

## Important notes

Processor speed indicates the internal clock speed of the processor; other factors also affect application performance.

CD or DVD drive speed is the variable read rate. Actual speeds vary and are often less than the possible maximum.

When referring to processor storage, real and virtual storage, or channel volume, KB stands for 1 024 bytes, MB stands for 1 048 576 bytes, and GB stands for 1 073 741 824 bytes.

When referring to hard disk drive capacity or communications volume, MB stands for 1 000 000 bytes, and GB stands for 1 000 000 000 bytes. Total user-accessible capacity can vary depending on operating environments.

Maximum internal hard disk drive capacities assume the replacement of any standard hard disk drives and population of all hard-disk-drive bays with the largest currently supported drives that are available from Lenovo.

Maximum memory might require replacement of the standard memory with an optional memory module.

Each solid-state memory cell has an intrinsic, finite number of write cycles that the cell can incur. Therefore, a solid-state device has a maximum number of write cycles that it can be subjected to, expressed as total bytes written (TBW). A device that has exceeded this limit might fail to respond to system-generated commands or might be incapable of being written to. Lenovo is not responsible for replacement of a device that has exceeded its maximum guaranteed number of program/erase cycles, as documented in the Official Published Specifications for the device.

Lenovo makes no representations or warranties with respect to non-Lenovo products. Support (if any) for the non-Lenovo products is provided by the third party, not Lenovo.

Some software might differ from its retail version (if available) and might not include user manuals or all program functionality.

---

## Electronic emission notices

When you attach a monitor to the equipment, you must use the designated monitor cable and any interference suppression devices that are supplied with the monitor.

Additional electronic emissions notices are available at:

[https://pubs.lenovo.com/important\\_notices/](https://pubs.lenovo.com/important_notices/)

## Taiwan Region BSMI RoHS declaration

單元 Unit	限用物質及其化學符號 Restricted substances and its chemical symbols					
	鉛Lead (PB)	汞Mercury (Hg)	鎘Cadmium (Cd)	六價鉻 Hexavalent chromium (Cr <sup>6+</sup> )	多溴聯苯 Polybrominated biphenyls (PBB)	多溴二苯醚 Polybrominated diphenyl ethers (PBDE)
機架	○	○	○	○	○	○
外部蓋板	○	○	○	○	○	○
機械組合作件	-	○	○	○	○	○
空氣傳動設備	-	○	○	○	○	○
冷卻組合作件	-	○	○	○	○	○
內存模組	-	○	○	○	○	○
處理器模組	-	○	○	○	○	○
電纜組合作件	-	○	○	○	○	○
電源供應器	-	○	○	○	○	○
儲備設備	-	○	○	○	○	○
印刷電路板	-	○	○	○	○	○
<p>備考1. “超出0.1 wt %” 及 “超出0.01 wt %” 係指限用物質之百分比含量超出百分比含量基準值。            Note1 : “exceeding 0.1wt%” and “exceeding 0.01 wt%” indicate that the percentage content of the restricted substance exceeds the reference percentage value of presence condition.</p> <p>備考2. “○” 係指該項限用物質之百分比含量未超出百分比含量基準值。            Note2 : “○” indicates that the percentage content of the restricted substance does not exceed the percentage of reference value of presence.</p> <p>備考3. “-” 係指該項限用物質為排除項目。            Note3 : The “-” indicates that the restricted substance corresponds to the exemption.</p>						

## Taiwan Region import and export contact information

Contacts are available for Taiwan Region import and export information.

委製商/進口商名稱: 台灣聯想環球科技股份有限公司  
 進口商地址: 台北市南港區三重路 66 號 8 樓  
 進口商電話: 0800-000-702





**Lenovo**