

**Acer Chromebook Plus 514  
CB514-3H/ CB514-3HT/ CBE574-1/ CBE574-1T**

## **Lifecycle Extension Guide**

# Table of Contents

---

- Self-Repair . . . . . 1**
- Disassembly Procedures . . . . . 2**
- Troubleshooting . . . . . 36**
- FRU (Field Replaceable Unit) List . . . . . 40**
- Exploded Diagrams . . . . . 41**
- Check for Updates Yourself . . . . . 45**
- Factory Reset Your Chromebook . . . . . 46**

# Self-Repair

---

This chapter highlights the limited self-repair capabilities of the product.

Prior performing self-repair, familiarize yourself with the Safety Guidelines and Recommended Equipment sections first as described in the chapter "[Disassembly Procedures](#)".

Depending on model, the following key components are eligible for self-repair (if applicable);

- Battery pack
- HDD / SSD module
- DIMM module(s)
- WLAN module
- LTE module

If a particular key component is listed and thus would be eligible for self-repair, but is not described in the "[Disassembly Procedures](#)" section, then this component is either not present on the respective model, or it is present but embedded on the motherboard and therefore not eligible for self-repair.

**⇒ NOTE:**

Do not attempt to replace other components than those listed above.

**⇒ NOTE:**

For replacement parts, always use only Acer certified components in order to safeguard quality, optimum system performance, stability and reliability of the product.

**⇒ NOTE:**

Any damage to the product that occur during self-repair, or which has occurred as a result of a careless or unsuccessful self-repair attempt, is not covered by the standard product warranty.

## Disassembly Procedures

Please refer to the chapter "[Disassembly Procedures](#)" for step by step disassembly instructions.

## Software Recovery

This product has embedded software recovery tools which can be used to either perform a partial or full software recovery, but also to create a Factory Default recovery media.

For more information about the software recovery options, how to perform a software recovery or creating a Factory Default recovery media, please refer to the chapter "Recovery" which is available in the User Manual of the product.

**⇒ NOTE:**

In the event of not being able to create a Factory Default recovery media, it is possible to obtain a copy of the recovery media through Acer Customer Service (<http://www.acer.com/support>)

This is not a free of charge service.

# Disassembly Procedures

---

## Safety Guidelines

This chapter contains step by step procedures on how to remove and de-install components from the computer. Use the following safety guidelines to ensure your personal safety. Each procedure included in this chapter assumes that you are preparing your computer for recycling and disposal. **By performing any of these procedures you acknowledge that any remaining warranty applicable to your computer will be voided. Before you start any of the procedures in this chapter, make sure to read the following safety guidelines and the respective instructions within the chapter.**

### CAUTION!

- Turn off your computer and disconnect all power sources before opening the computer cover or panels.
- To avoid electrostatic discharge, ground yourself by using a wrist grounding strap or by periodically touching an unpainted metal surface at the same time as touching a connector on the back of the computer.
- Take off any metal objects on your arms or fingers such as bracelets, rings or watches and make sure your hands are completely dry. Even if your unit is unplugged, there may still be some remaining electric charge.
- If a component does not come out easily, do not forcefully remove it. Instead, check that you are removing it correctly and that no wires or other parts are in the way.
- When you disconnect a cable, pull on its connector or on its pull-tab, not on the cable itself. Some cables have connectors with locking tabs; if you are disconnecting this type of cable, press in on the locking tabs before you disconnect the cable.

## Recommended Equipment

The following tools are required to perform maintenance on the notebook:

- Wrist grounding strap and conductive mat
- Flat screwdriver
- Philips screwdriver
- Pointed plastic pry or similar object
- Tweezers

# WEEE Annex VII Component

These components are classified as requiring selective treatment:

- WLAN Module
- Battery
- SSD Module
- Touchpad
- Mainboard
- USB Board
- LCD Panel

# Getting Started

Perform the following prior to performing any maintenance procedures:

1. Place the system on a flat work surface.
2. Make sure the system is completely powered down.
  - a. If the device is in powered up mode, shut down the system normally.
  - b. If the device is in sleep mode, wait for the Home Screen to clear. Then, shut down normally.
3. Disconnect the AC Adapter and remove all cables from the system and its peripherals.



**Figure 1-1. Disconnecting the Power Adapter**

## Lower Case Removal

1. Remove the ten (10) screws securing the lower case to the upper case.

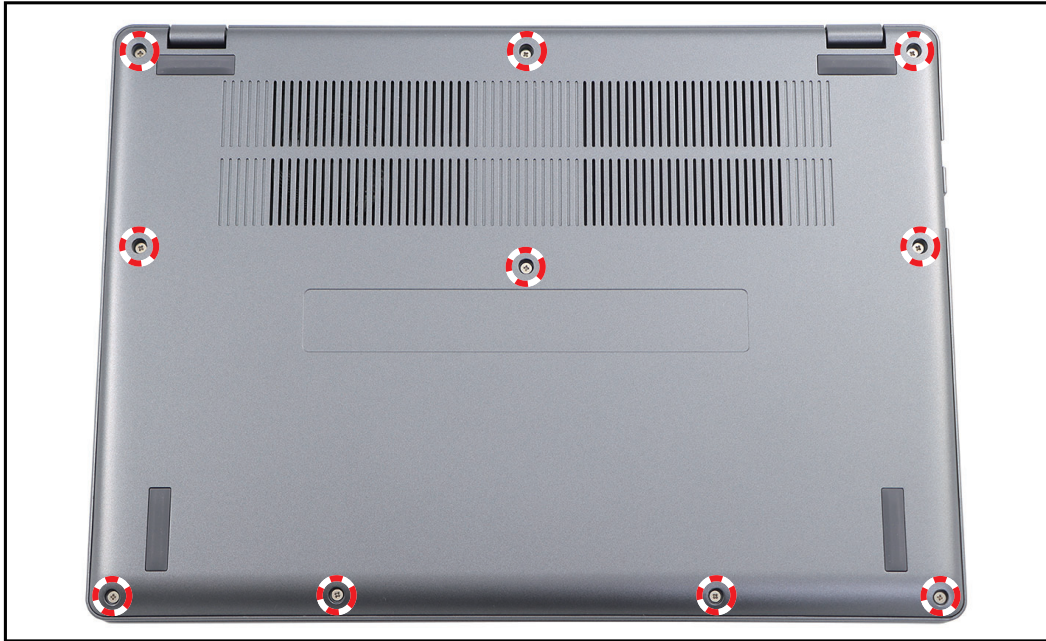

**Figure 1-2. Removing the Screws**

2. Starting from the bottom left and right sides, pry to release the latches.

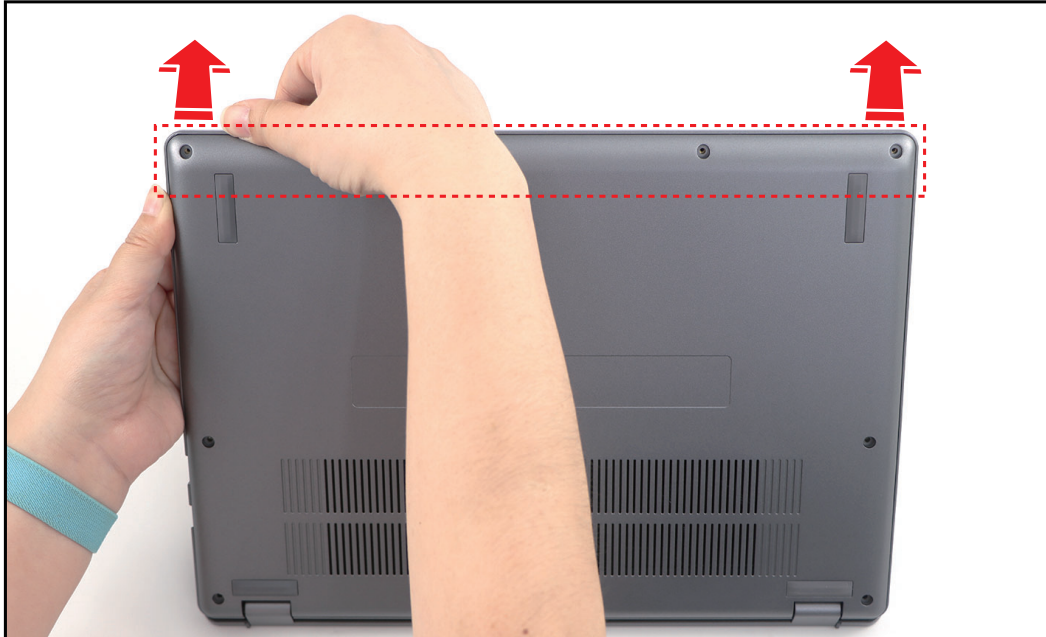

**Figure 1-3. Releasing the Lower Case**

- Continue releasing the remaining latches and then remove the lower case.



Figure 1-4. Removing the Lower Case

- Detach the acetate tapes from the battery cable connector.

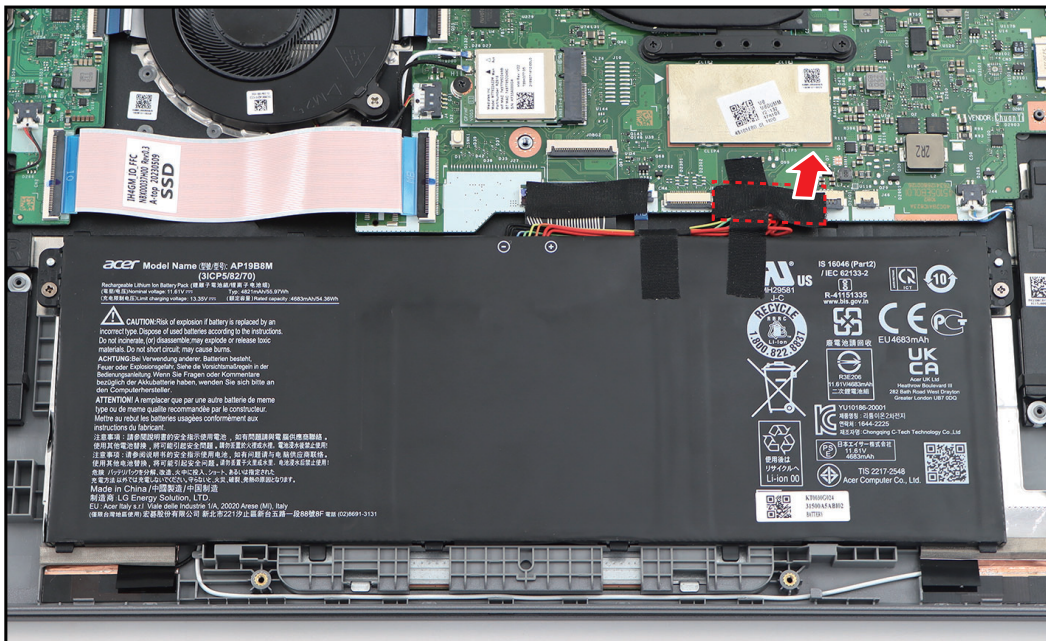

Figure 1-5. Detaching the Acetate Tapes (1 of 2)



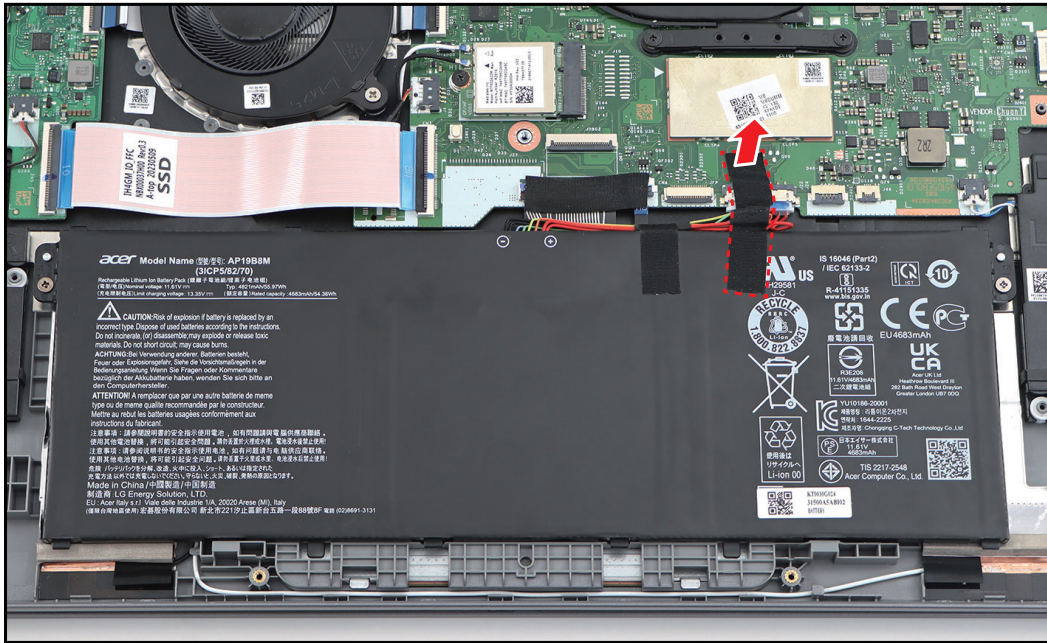

Figure 1-6. Detaching the Acetate Tape (2 of 2)

5. Disconnect the battery cable from the mainboard connector.

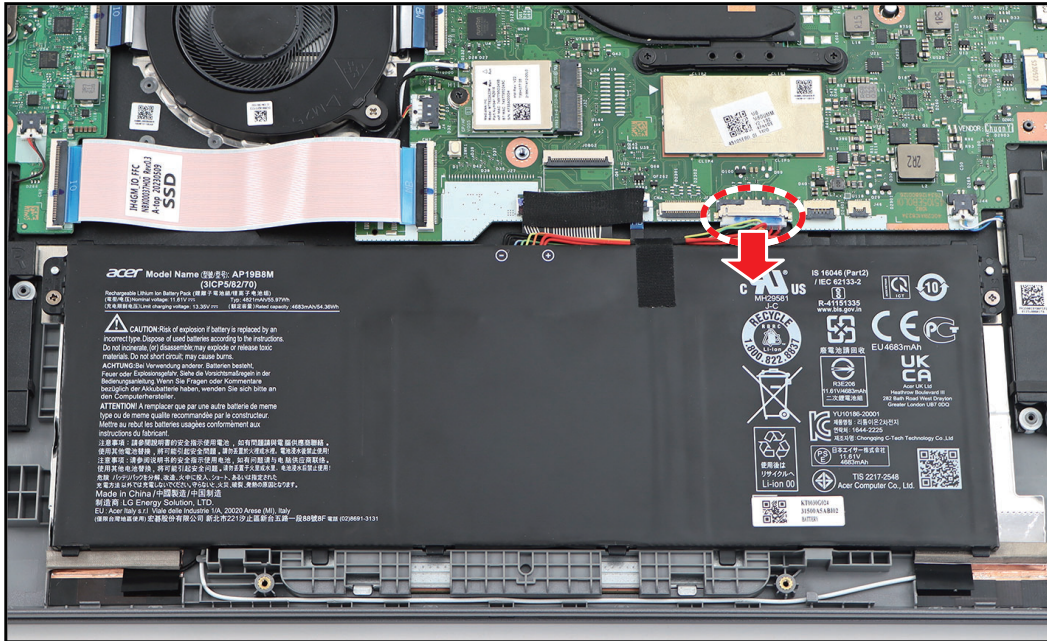



Figure 1-7. Disconnecting the Battery Cable

Table 1-1. Lower Case Screws

Screw Name	Screw Type	Torque	Quantity
M 2.0 x 6.0		2.0~2.2kgf.cm	10

# WLAN Module Removal

Prerequisite:

※ **Lower Case Removal** on page 1-5

1. Disconnect the WLAN antenna cables.

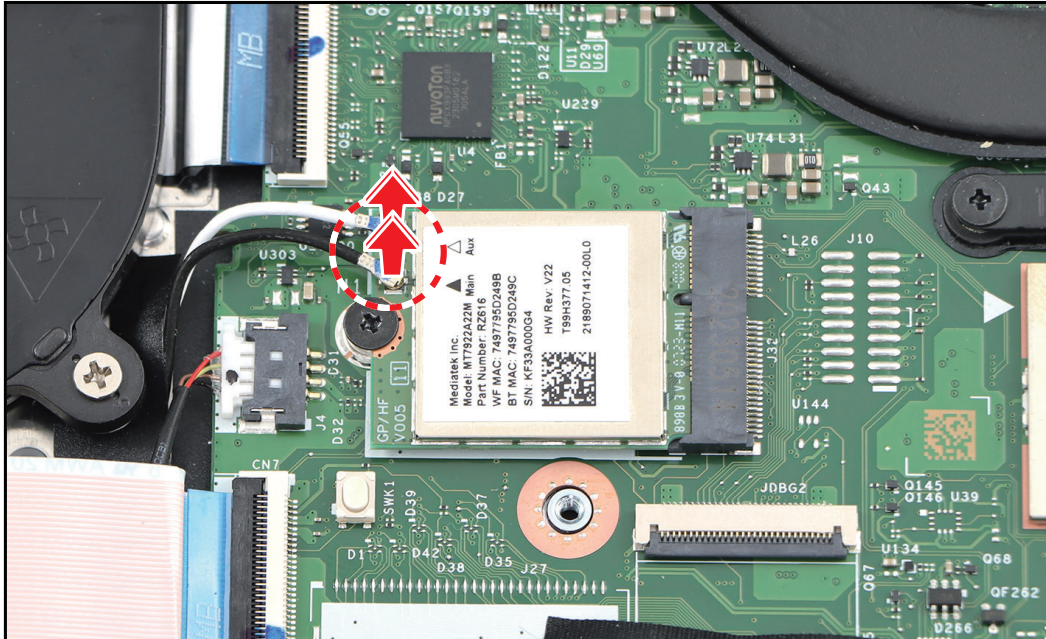

Figure 1-8. Disconnecting the WLAN Antenna Cables

2. Remove the screw securing the WLAN module to the mainboard.

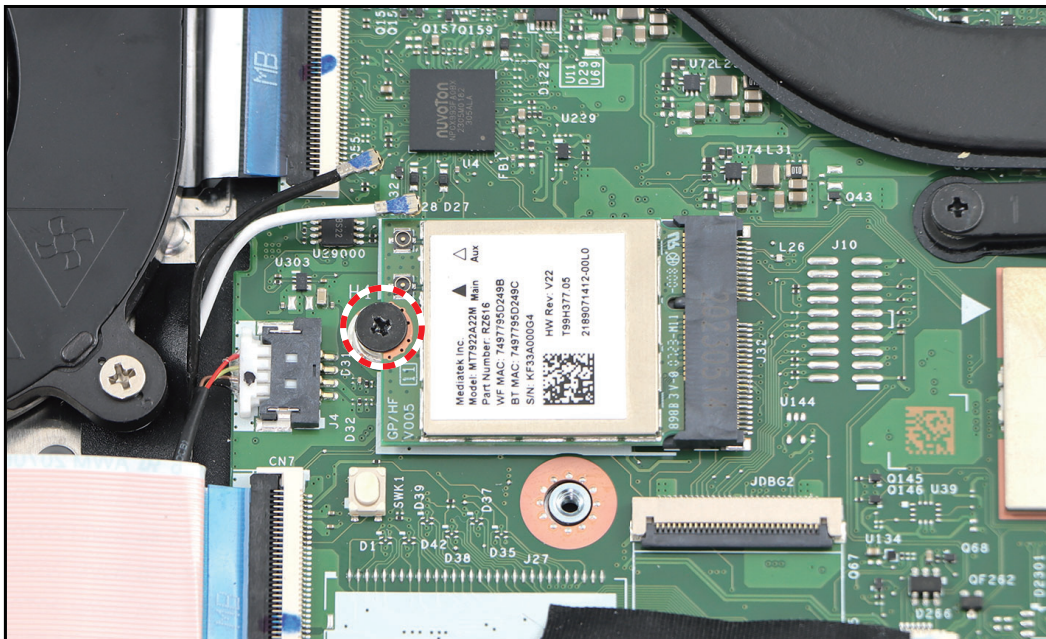
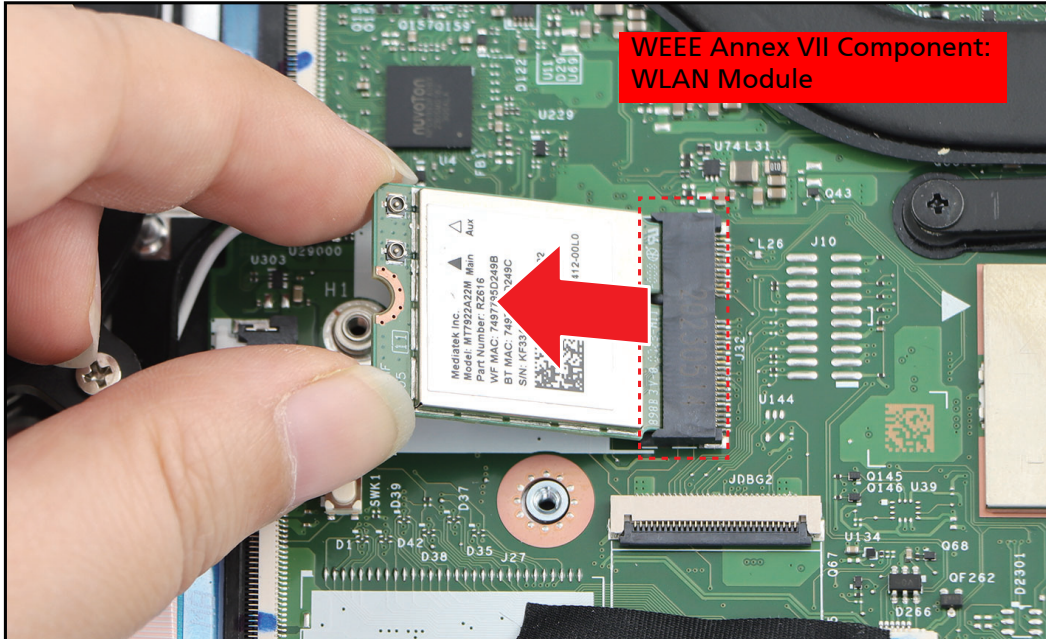



Figure 1-9. Removing the Screw

3. Pull to disconnect the WLAN module from the mainboard connector. Then remove the WLAN module.



**Figure 1-10. Removing the WLAN Module**

**Table 1-2. WLAN Module Screw**

Screw Name	Screw Type	Torque	Quantity
M 2.0 x 2.5		1.8~2.2kgf.cm	1

# Battery Removal

Prerequisite:

※ **Lower Case Removal** on page 1-5

1. Remove the two (2) screws securing the battery to the upper case.



Figure 1-11. Removing the Screws

2. Lift the battery and remove it from the system.

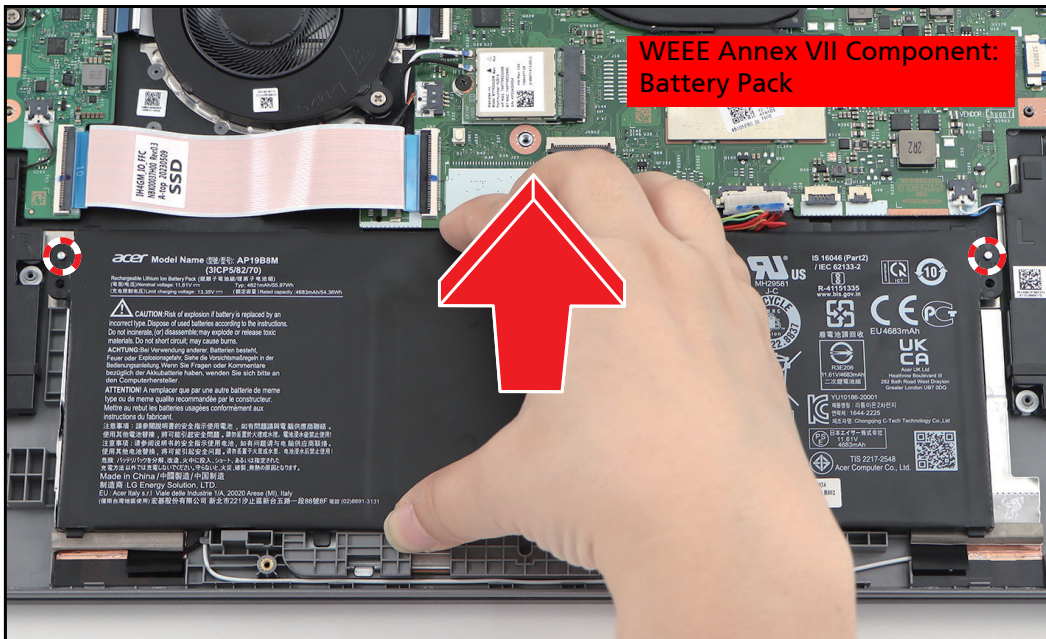



Figure 1-12. Disconnecting the Battery Cable

**Table 1-3. Battery Screws**

<b>Screw Name</b>	<b>Screw Type</b>	<b>Torque</b>	<b>Quantity</b>
M 2.0 x 4.0		1.8~2.2kgf.cm	2

# SSD Module Removal

Prerequisite:

※ [Lower Case Removal](#) on page 1-5

1. Release the latches and disconnect the USB board FFC from the USB and mainboard connectors. Remove the USB board FFC from the system.

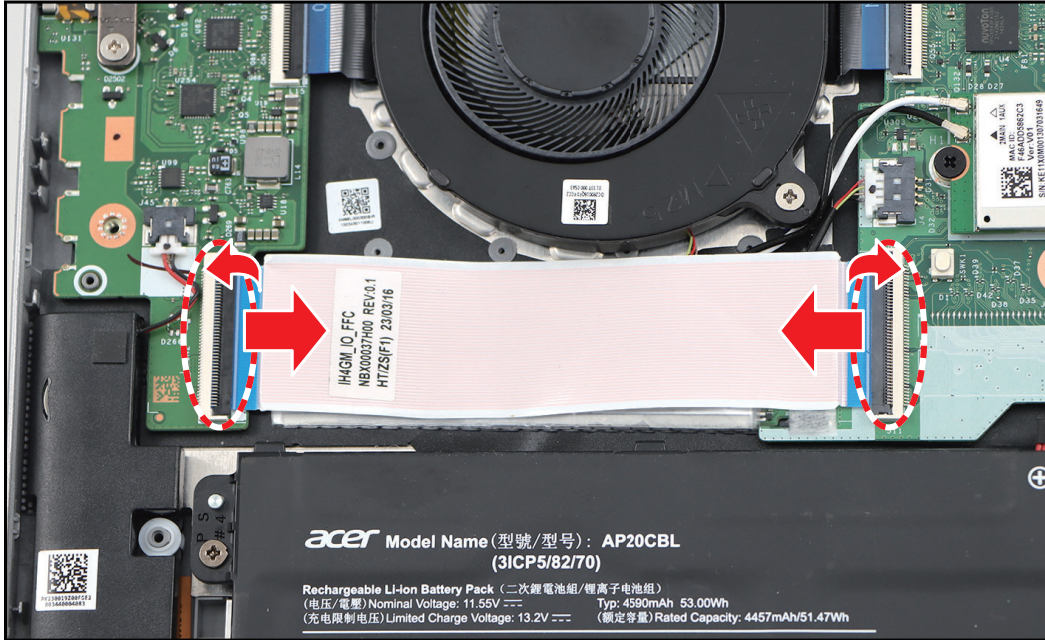
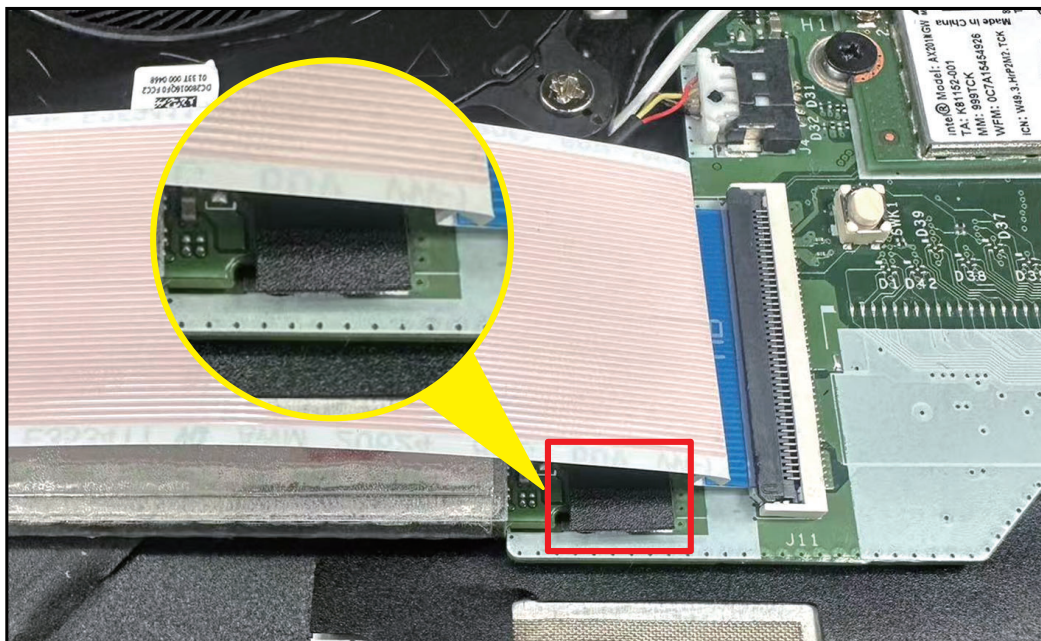

Figure 1-13. Removing the USB Board FFC

⇒ **NOTE:** For non-SSD SKU, if there is black mylar attached underneath the USB board FFC, then follow steps “a” to “e” to disconnect the USB board FFC from the mainboard connector:

a) Locate the black mylar underneath the USB board FFC.



**Figure 1-14. Locating the Black Mylar**

b) Hold the black mylar in place.

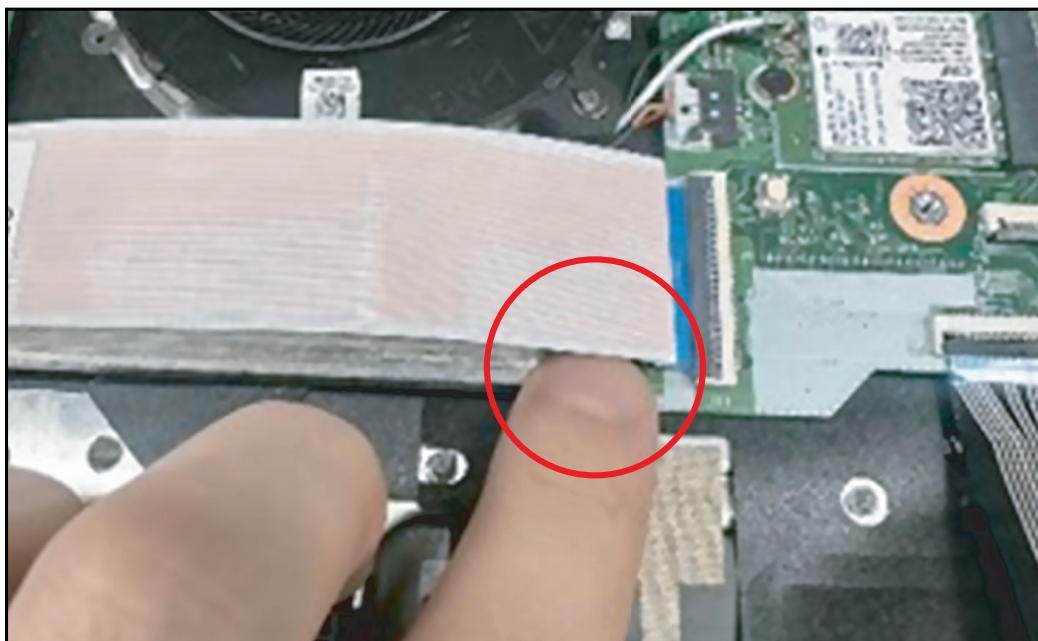

**Figure 1-15. Holding the Black Mylar In Place**

c) Release the USB board FFC latch.

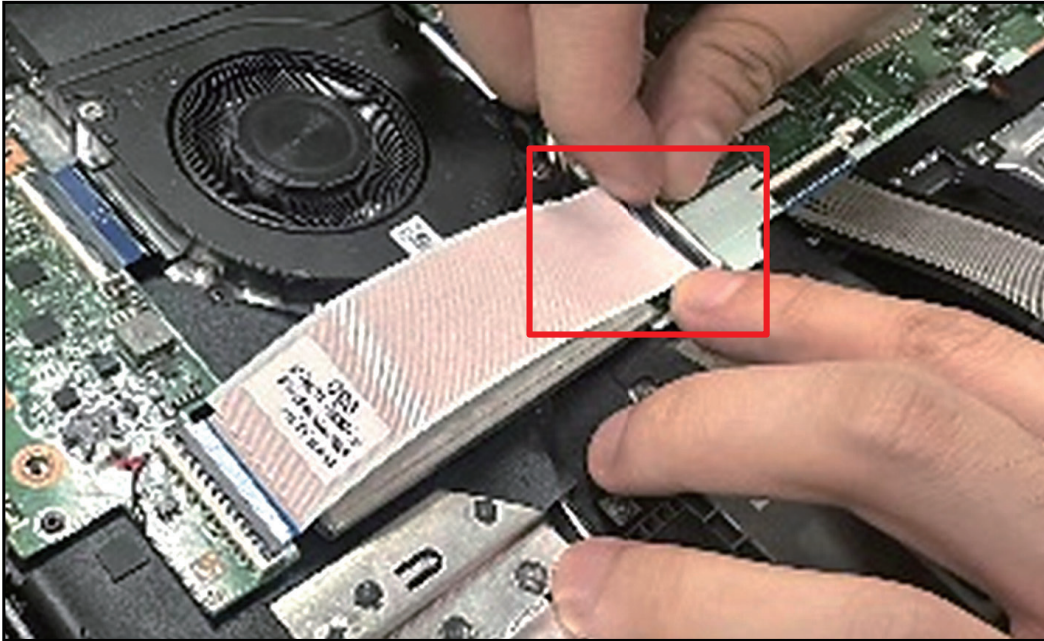

**Figure 1-16. Releasing the USB Board FFC Latch**

d) Disconnect the USB board FFC from the mainboard connector and release it from the black mylar.

e) Release the hand holding the black mylar.

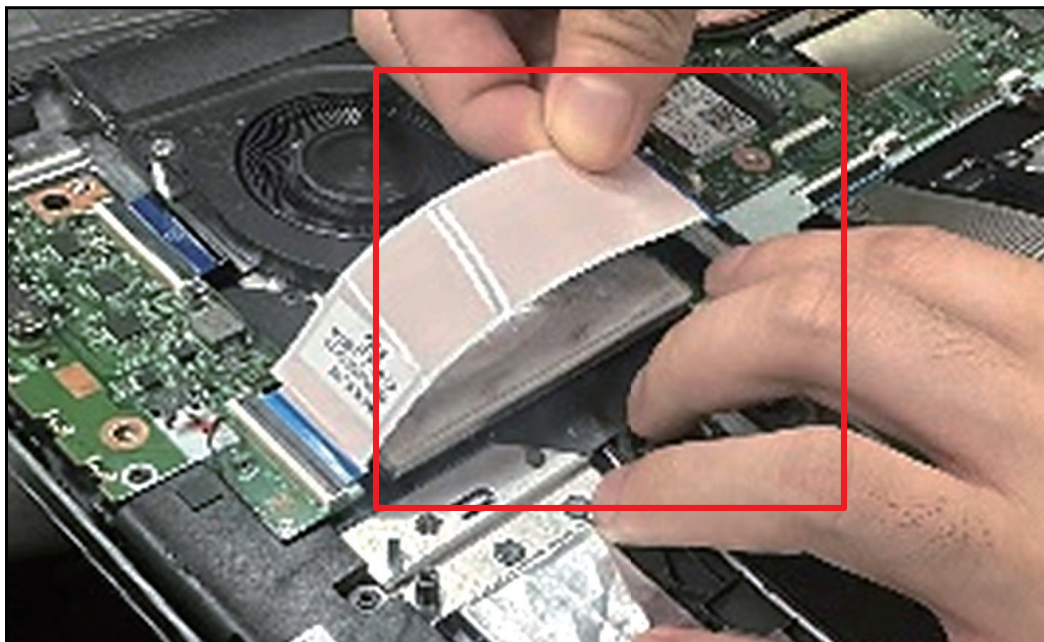

**Figure 1-17. Disconnecting the USB Board FFC**



2. Remove the screw securing the SSD module to the keyboard plate.

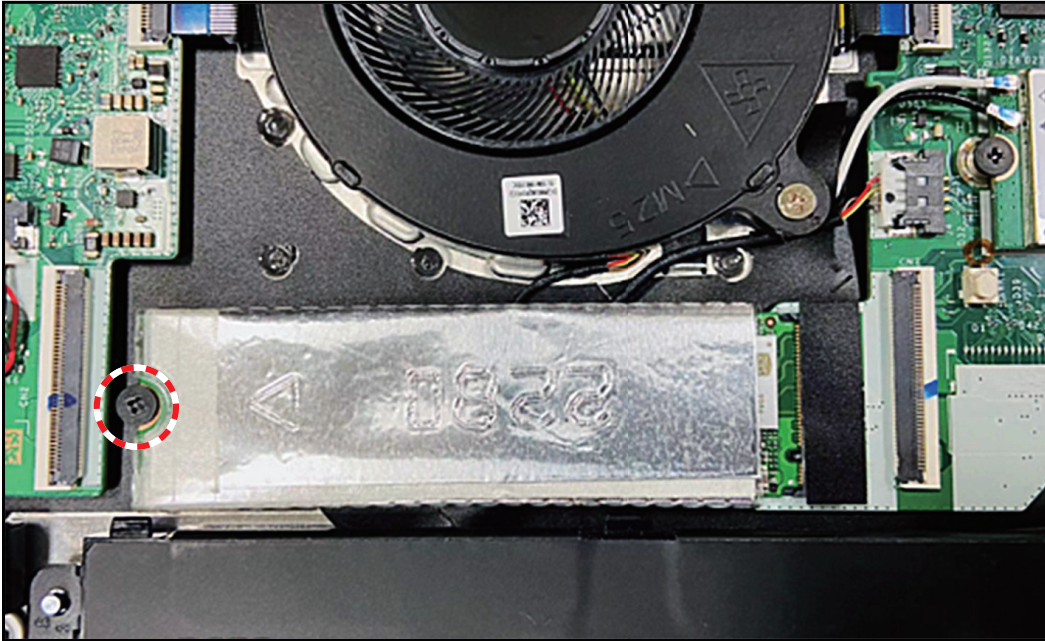

Figure 1-18. Removing the Screw

3. Pull to disconnect the SSD module from the mainboard connector. Then remove the SSD module.



Figure 1-19. Removing the SSD Module

- Remove the SSD module from the foil cover.

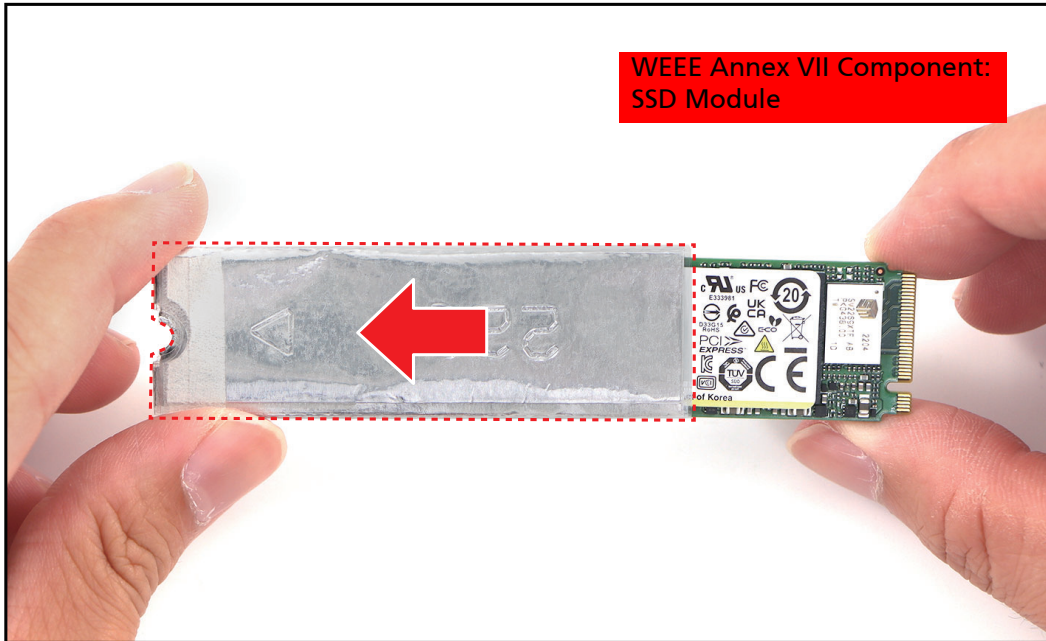



Figure 1-20. Removing the SSD Module from the Foil Cover

Table 1-4. SSD Module Screw

Screw Name	Screw Type	Torque	Quantity
M 2.0 x 2.5		1.8~2.2kgf.cm	1

# LCD Module Removal

Prerequisite:

※ [Lower Case Removal](#) on page 1-5

1. Release the eDP cable latch.

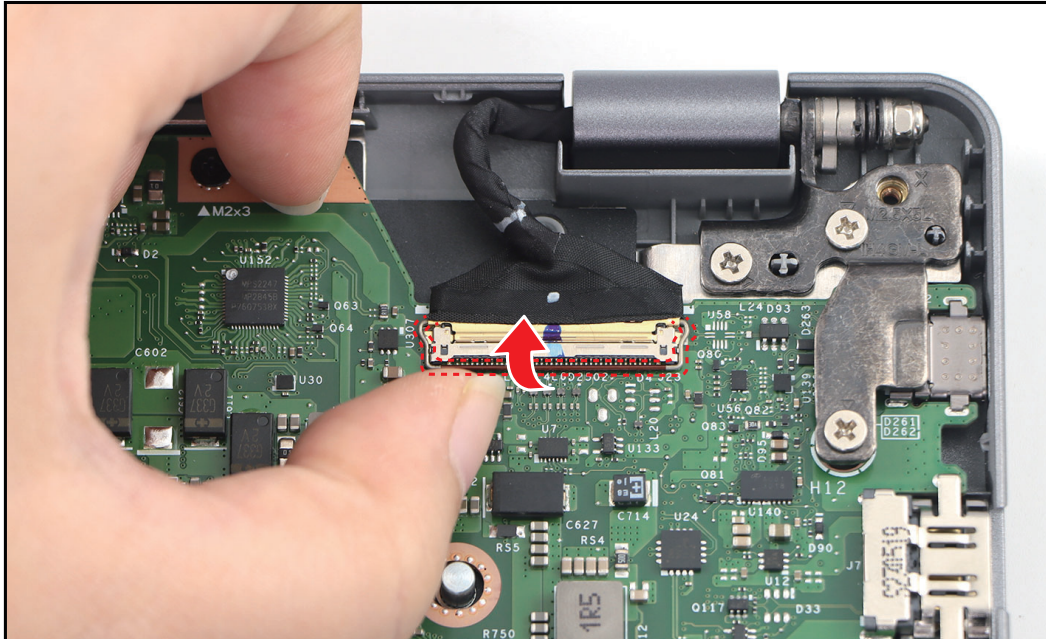

Figure 1-21. Releasing the eDP Cable Latch

2. Disconnect the eDP cable from the mainboard connector and unroute it from the upper case.

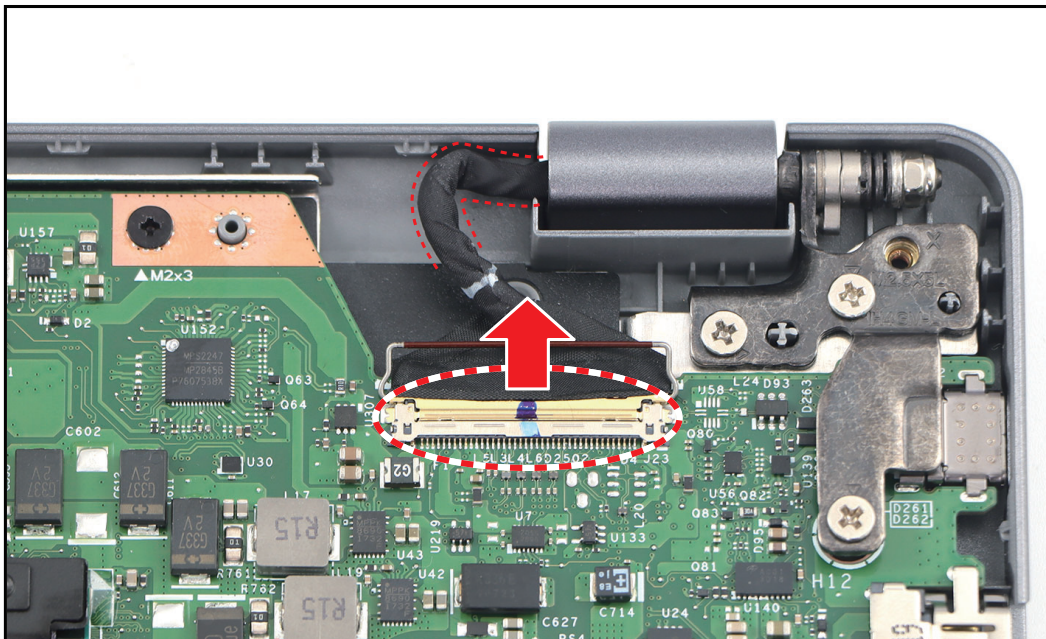
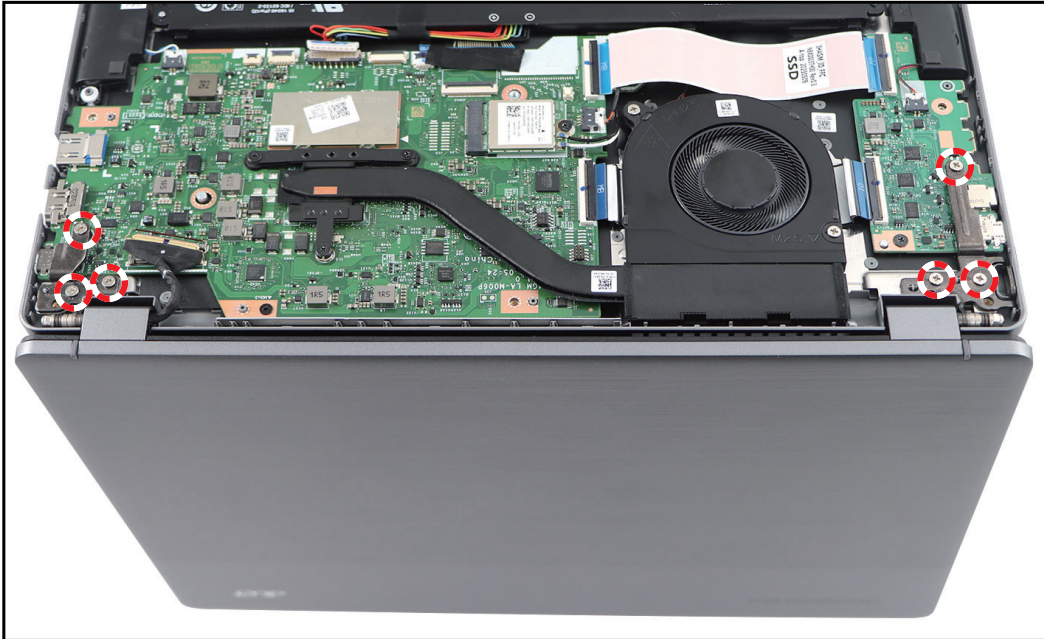

Figure 1-22. Disconnecting the eDP Cable

- Remove the six (6) screws securing the LCD hinges and LCD module to the upper case.



**Figure 1-23. Removing the Screws**

- Remove the LCD module away from the upper case.

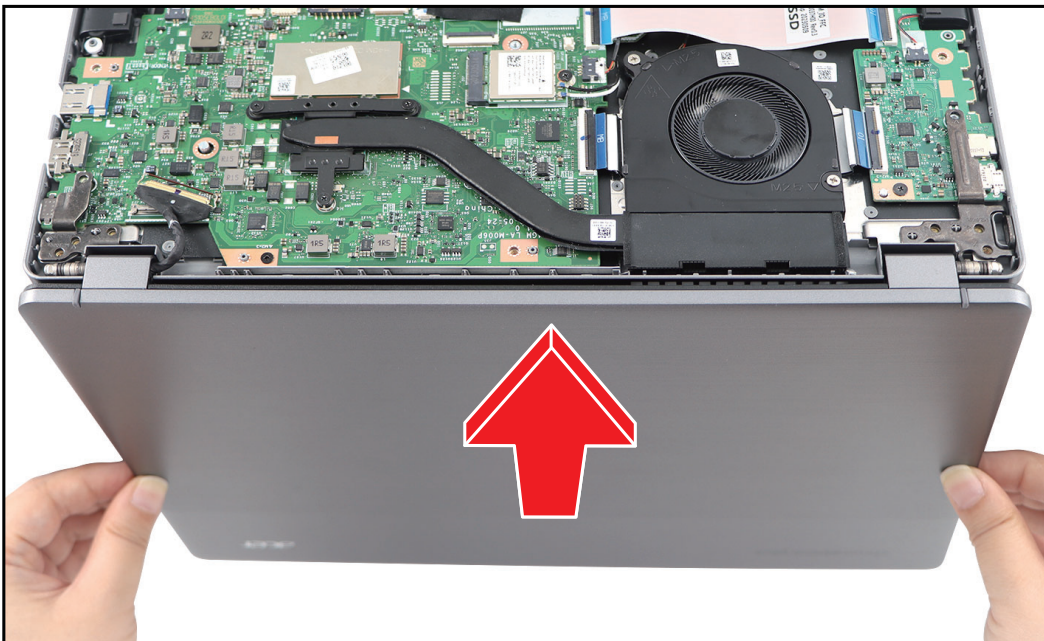

**Figure 1-24. Removing the LCD Module**

**Table 1-5. LCD Hinge Screws**

Screw Name	Screw Type	Torque	Quantity
M 2.5 x 5.0		2.65~3.45kgf.cm	6

# Touchpad Removal

Prerequisite:

- ※ [Battery Removal](#) on page 1-10

1. Detach the acetate tape from the keyboard FPC connector.

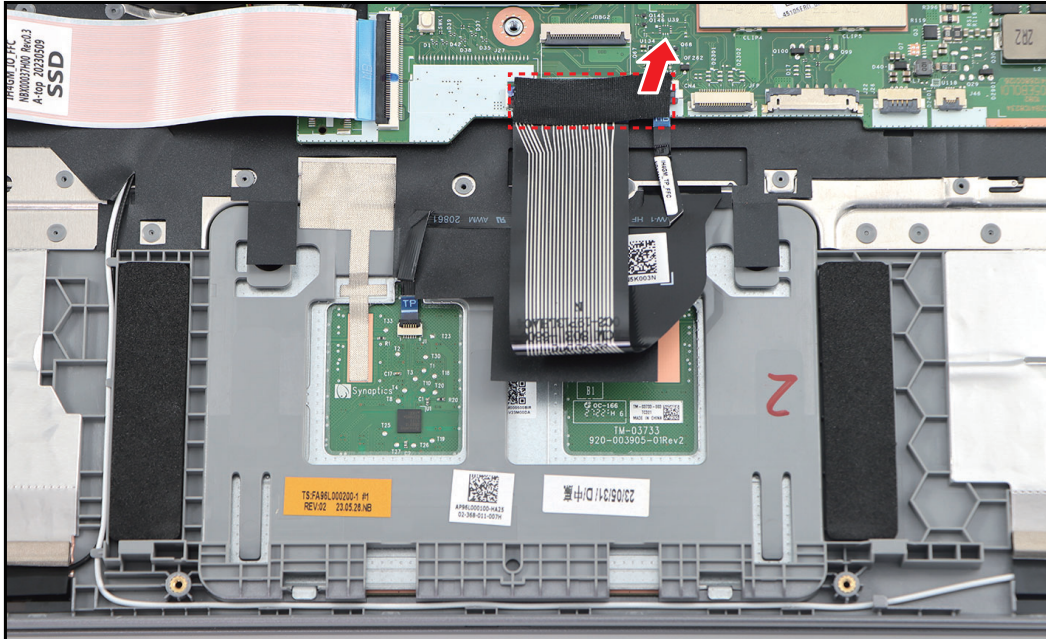

Figure 1-25. Detaching the Acetate Tape

2. Release the latch and disconnect the keyboard FPC from the mainboard connector.

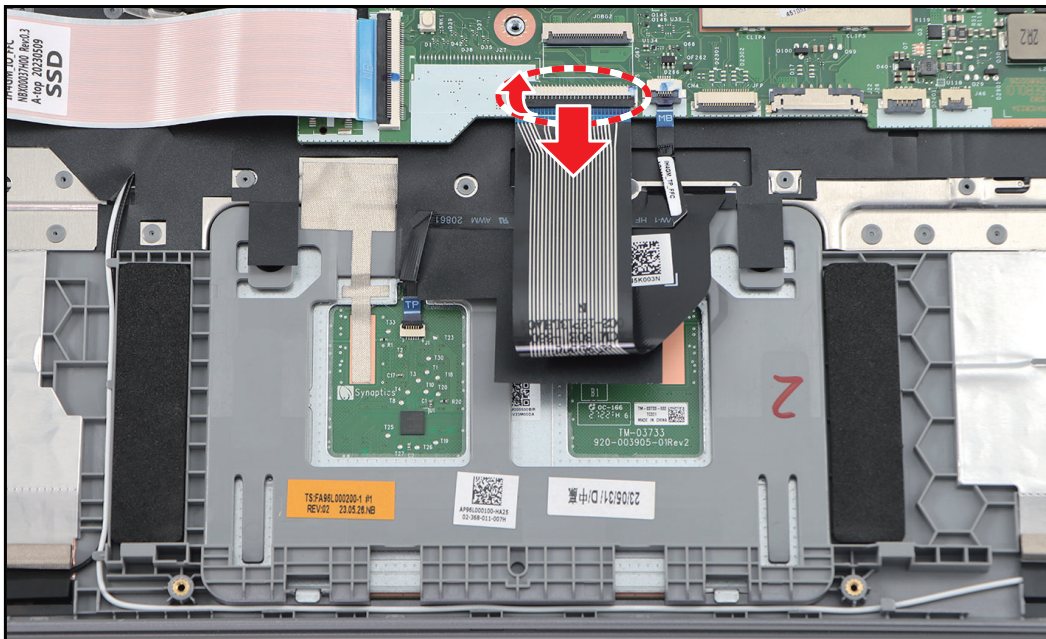
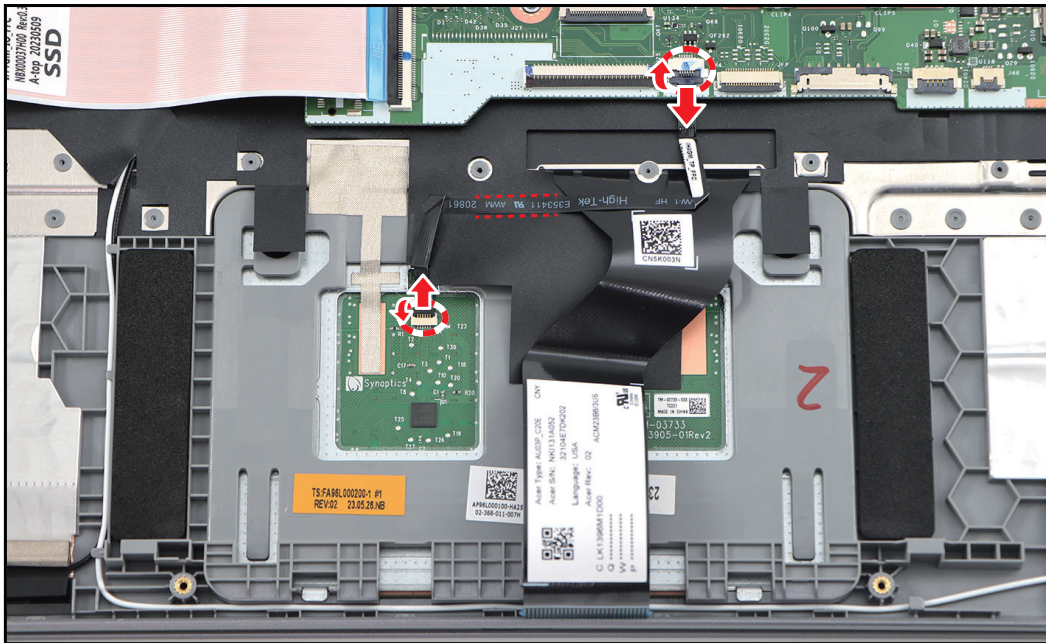

Figure 1-26. Disconnecting the Keyboard FPC

3. Release the latches and disconnect the touchpad FFC from the mainboard and touchpad connectors. Release the portion of the touchpad FFC from the upper case and then remove it.

**⇒ NOTE:**

When removing the FFC, carefully lift the portion of the touchpad FFC (marked with red dashed line in the illustration below) to detach it from the adhesive tape underneath.



**Figure 1-27. Removing the Touchpad FFC**

4. Detach the conductive tape from the touchpad and the upper case.

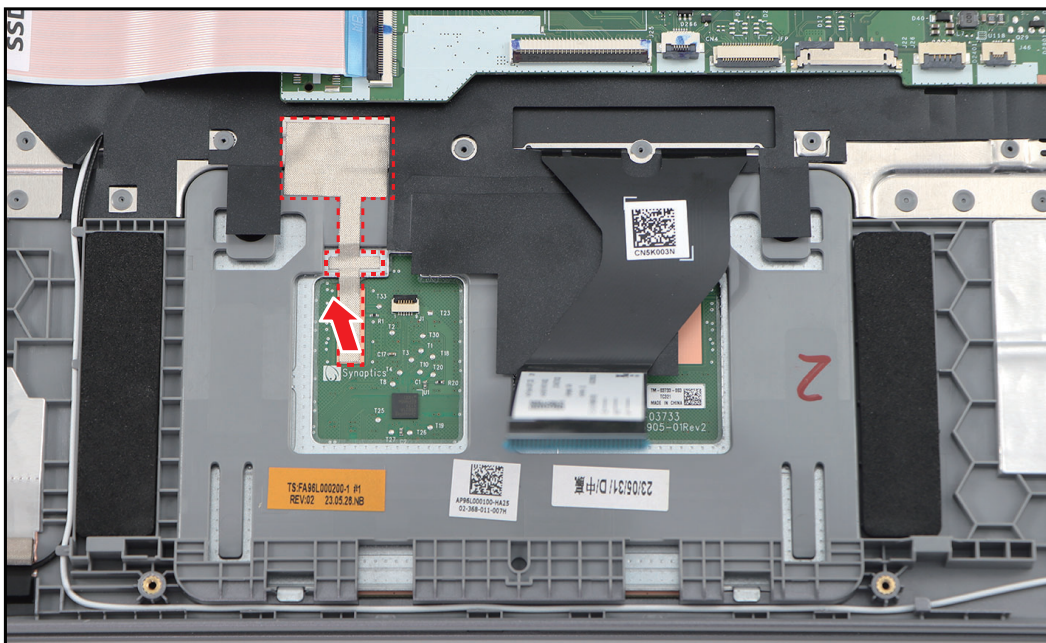

**Figure 1-28. Detaching the Conductive Tape**

- Remove the two (2) screws securing the touchpad to the upper case.

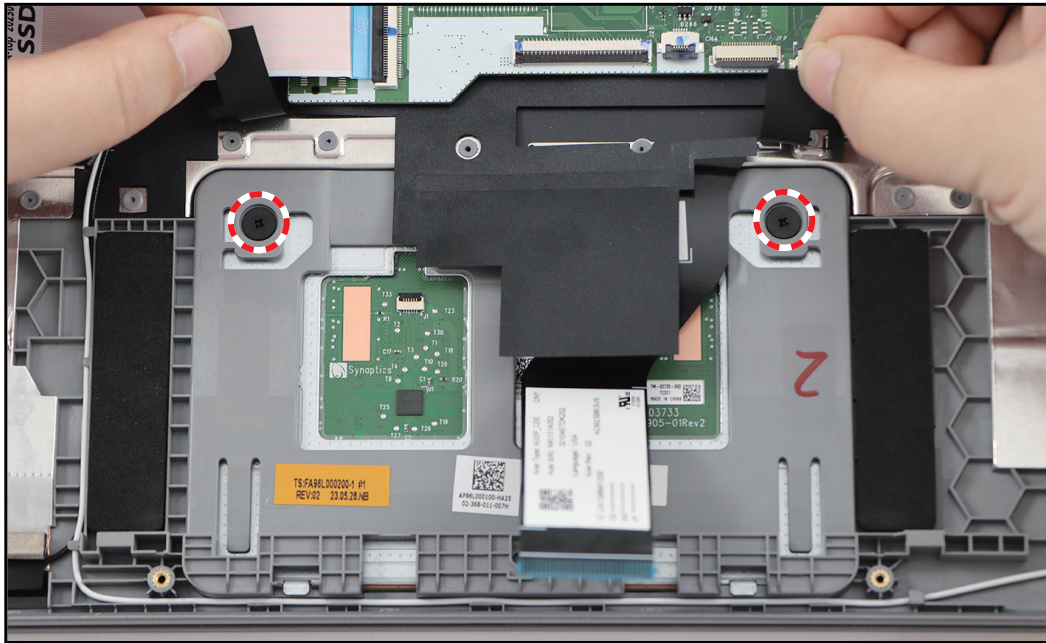

**Figure 1-29. Removing the Screws**

- Place one of your hands underneath the touchpad. Use a pointed device to push on the screw holes and then slide the bottom part of the touchpad forward to disengage it from the latches. Remove the touchpad from the upper case.

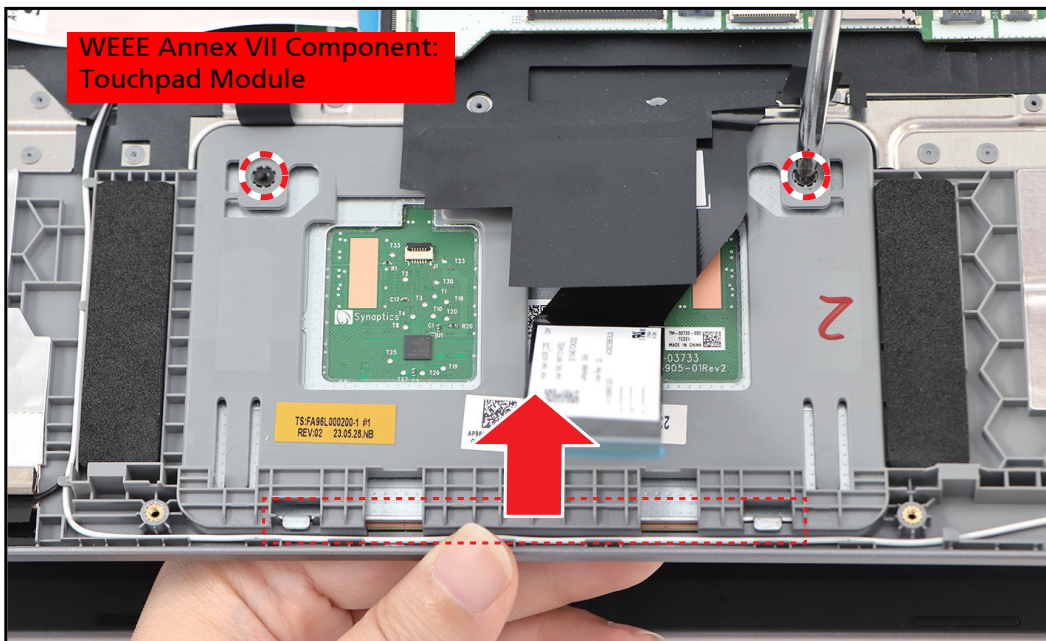

**Figure 1-30. Removing the Touchpad**

**Table 1-6. Touchpad Screws**

Screw Name	Screw Type	Torque	Quantity
M 2.0 x 2.0		1.8~2.2kgf.cm	2

# Mainboard Removal

## Prerequisite:

- \* [WLAN Module Removal](#) on page 1-8
- \* Thermal Module Removal
- \* [Battery Removal](#) on page 1-10
- \* Fan Module Removal
- \* [LCD Module Removal](#) on page 1-17

1. Detach the acetate tape from the keyboard FPC connector.

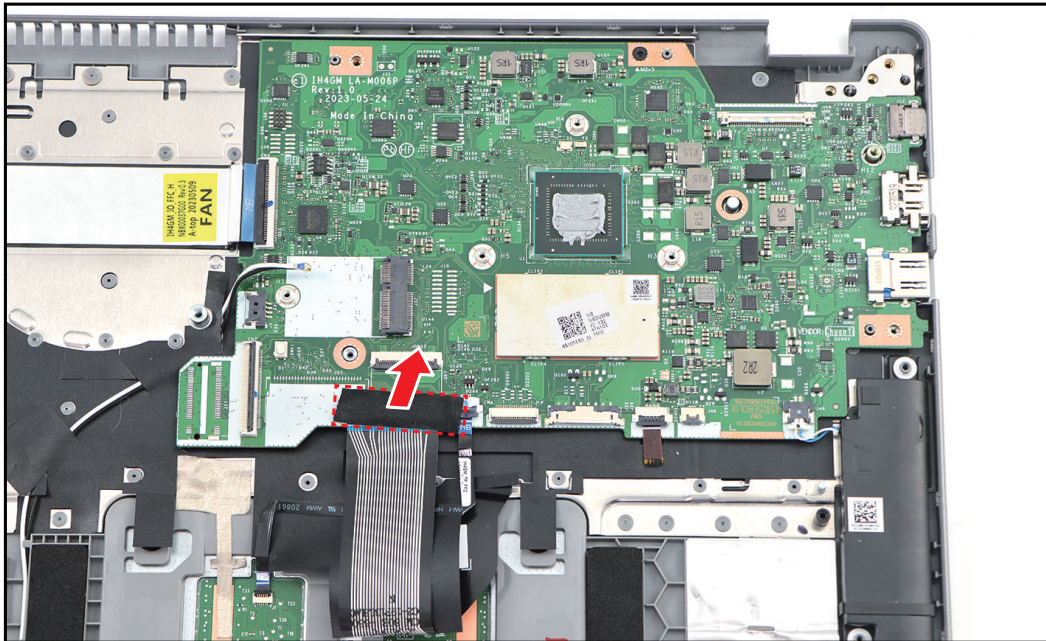

**Figure 1-31. Detaching the Acetate Tape**



2. Release the latch (if necessary) and disconnect the following cables from the mainboard connectors:
  - USB board FFC (A)
  - Keyboard FPC (B)
  - Touchpad FFC (C)
  - Keyboard backlight FPC (D)
  - Left speaker cable (E).

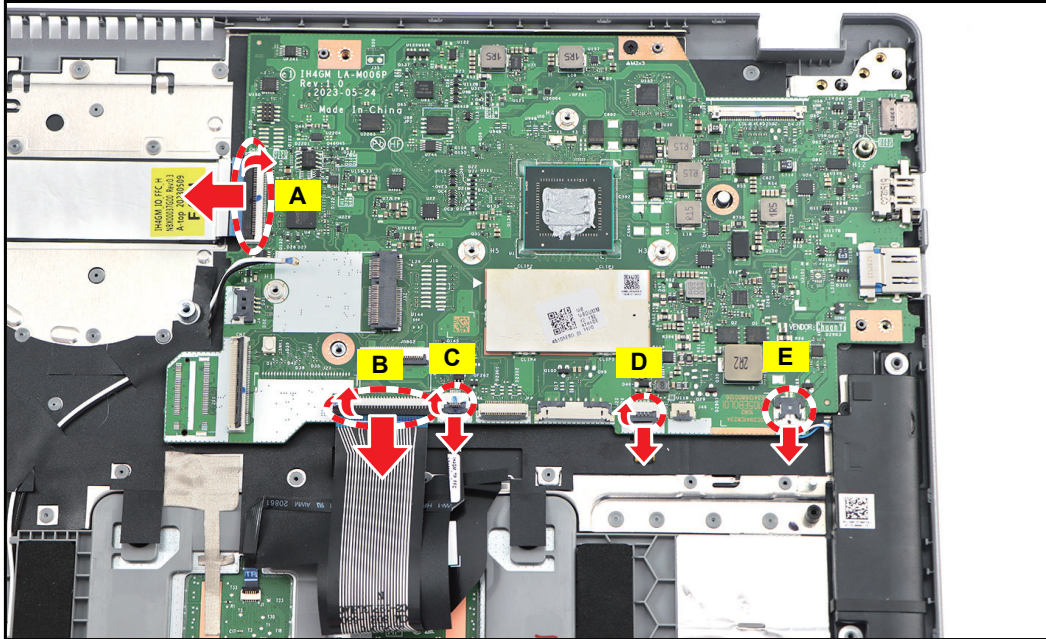

Figure 1-32. Disconnecting the Cables

3. Remove the screw securing the mainboard to the upper case.

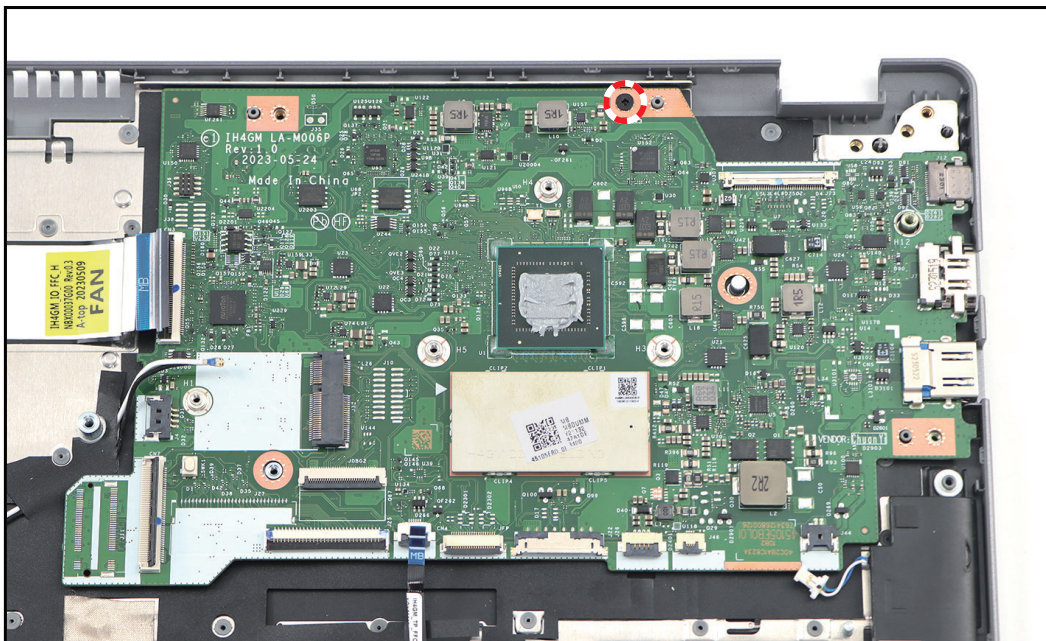
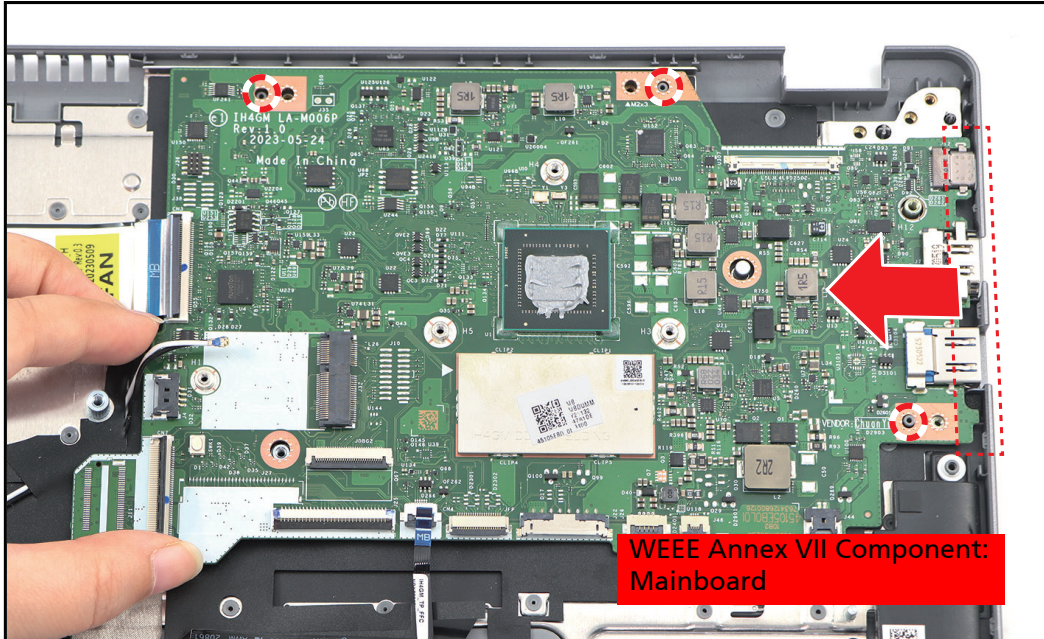



Figure 1-33. Removing the Screw

4. Slightly lift the mainboard to release it from the guides and then slide it to release the I/O connectors from their slots. Remove the mainboard from the upper case.



**Figure 1-34. Removing the Mainboard**

**Table 1-7. Mainboard Screw**

Screw Name	Screw Type	Torque	Quantity
M 2.0 x 3.0		1.8~2.2kgf.cm	1

# USB Board Removal

## Prerequisite:

- ※ Fan Module Removal
- ※ [LCD Module Removal](#) on page 1-17
- ※ Right Speaker Removal

1. Release the latches and disconnect the USB board FFC from the USB board and mainboard connectors.
2. Detach and remove the USB board FFC from the upper case.

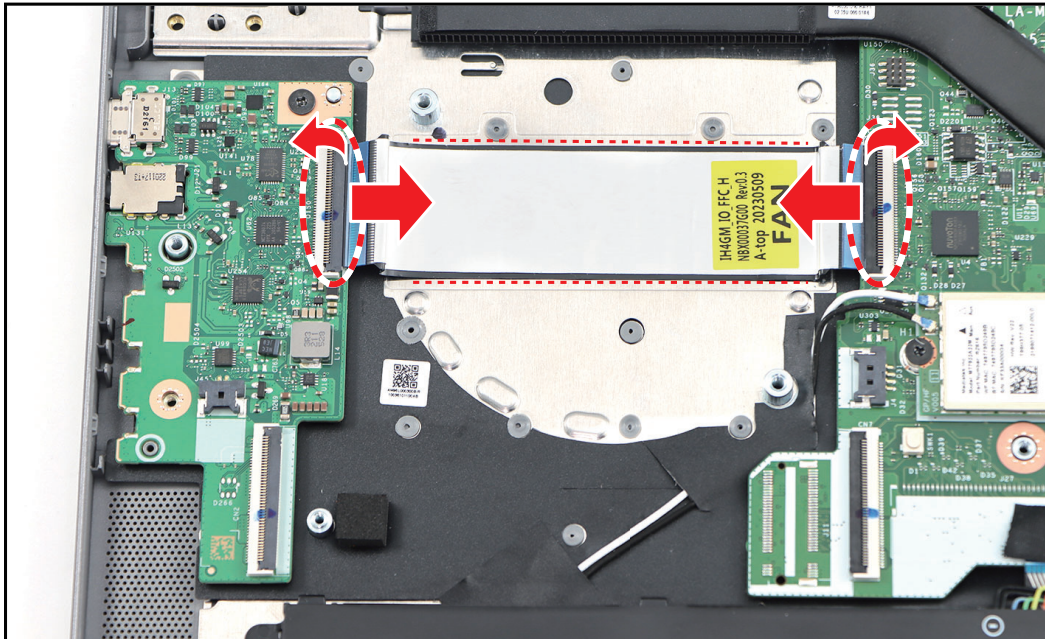
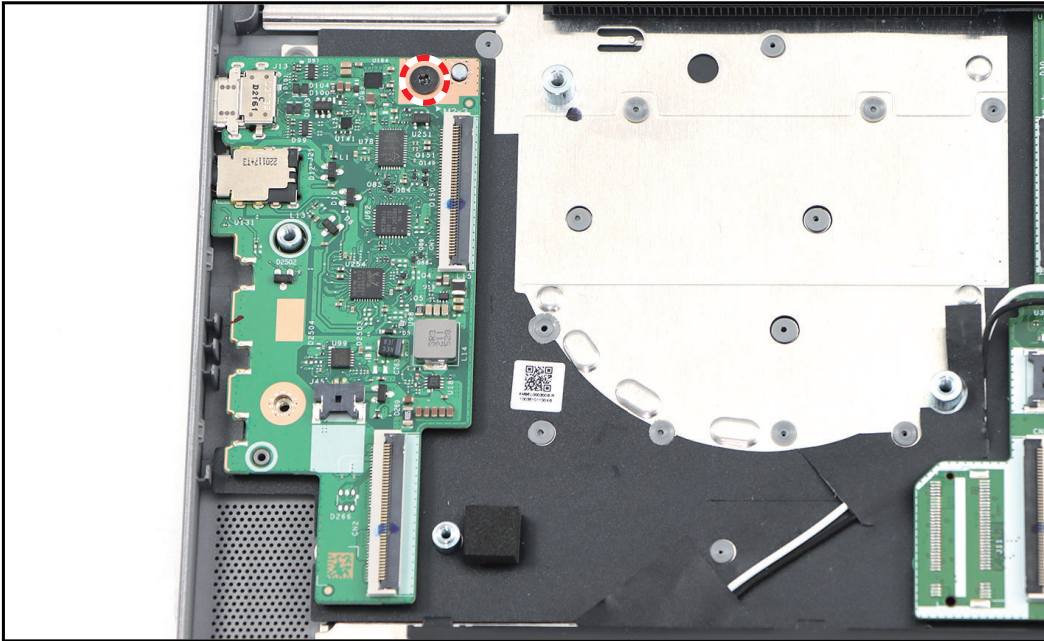

Figure 1-35. Removing the USB Board FFC

3. Remove the screw securing the USB board to the upper case.



**Figure 1-36. Removing the Screw**

4. Slightly lift the USB board to release it from the guide pins and then slide it to release the I/O connectors from their slots.
5. Remove the USB board from the upper case.

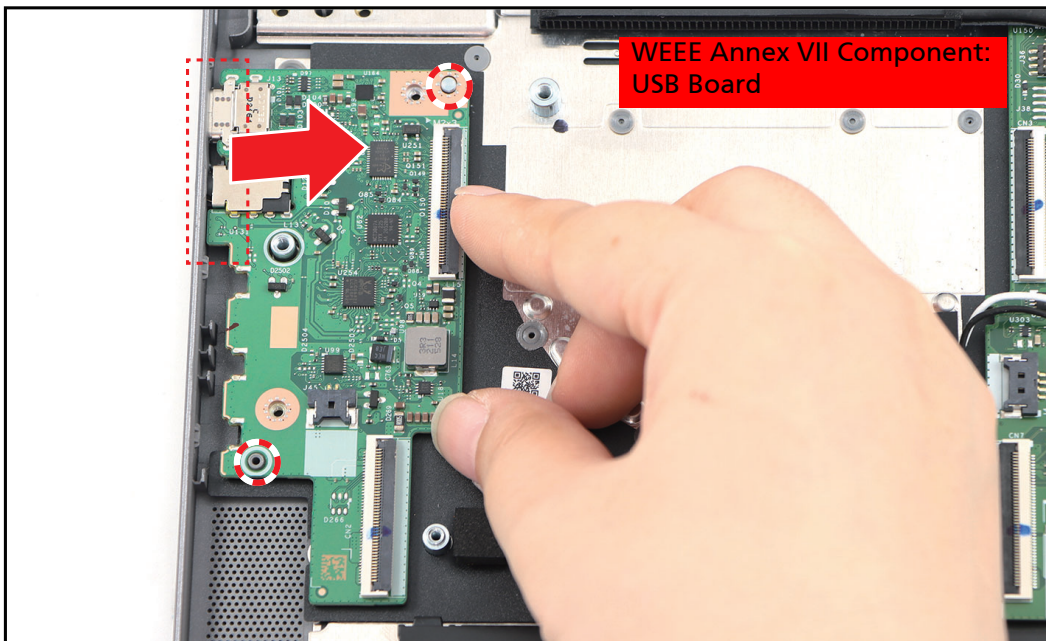

**Figure 1-37. Removing the USB Board**

**Table 1-8. USB Board Screw**

Screw Name	Screw Type	Torque	Quantity
M 2.0 x 3.0		1.8~2.2kgf.cm	1

# LCD Bezel Removal

Prerequisite:

※ [LCD Module Removal](#) on page 1-17

1. Push down both LCD hinges.



Figure 1-38. Pushing Down the LCD Hinges

2. Pry the LCD bezel from the upper side to release the latches.

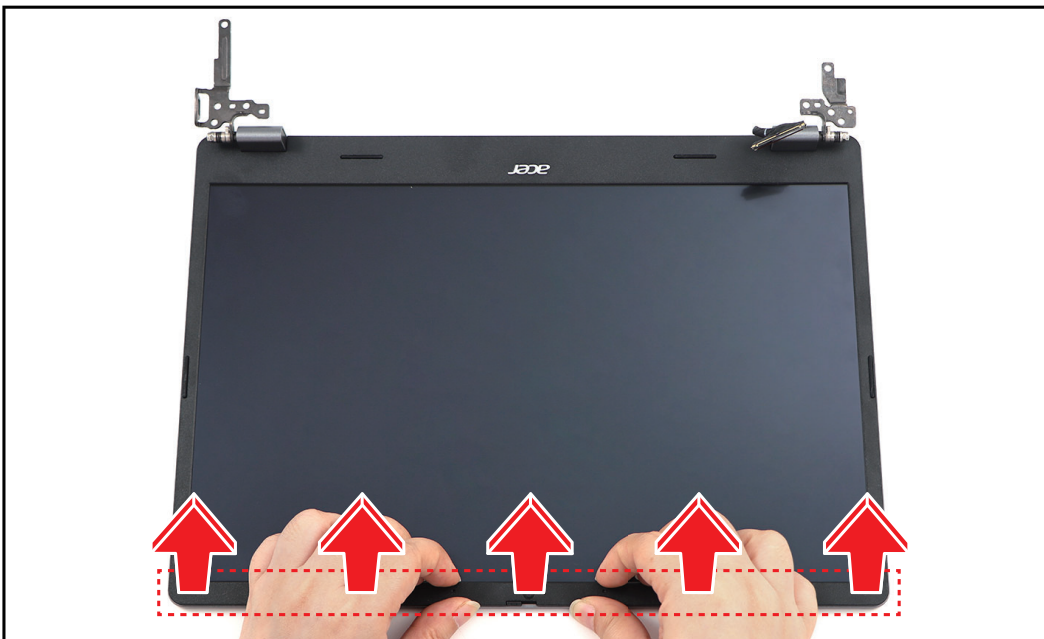
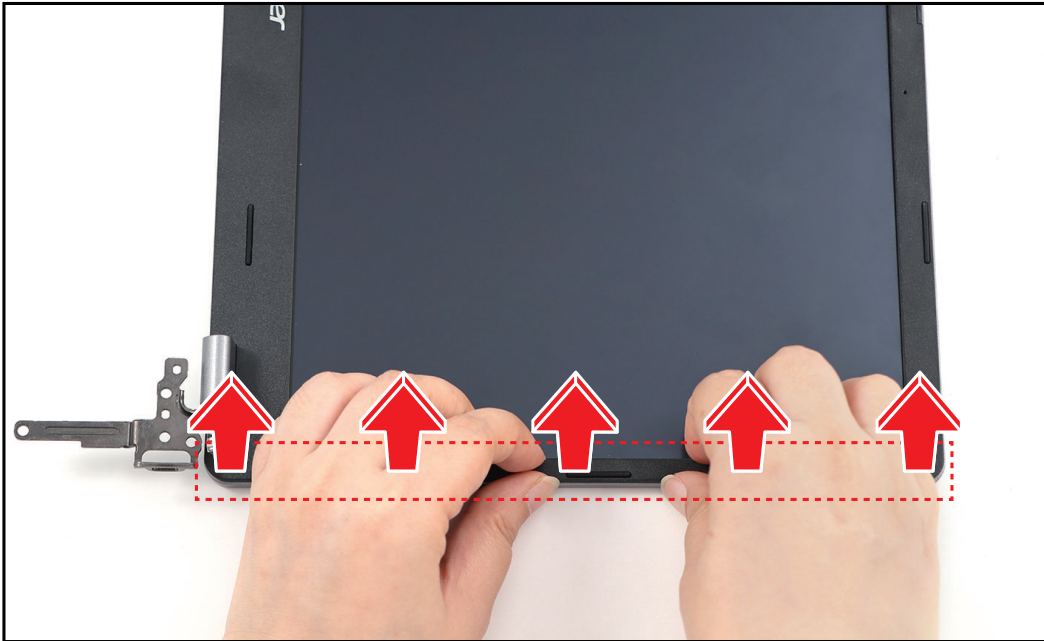

Figure 1-39. Removing the LCD Bezel (1 of 4)

3. Continue to release the right side latches.



**Figure 1-40. Removing the LCD Bezel (2 of 4)**

4. Pry the left side latches.

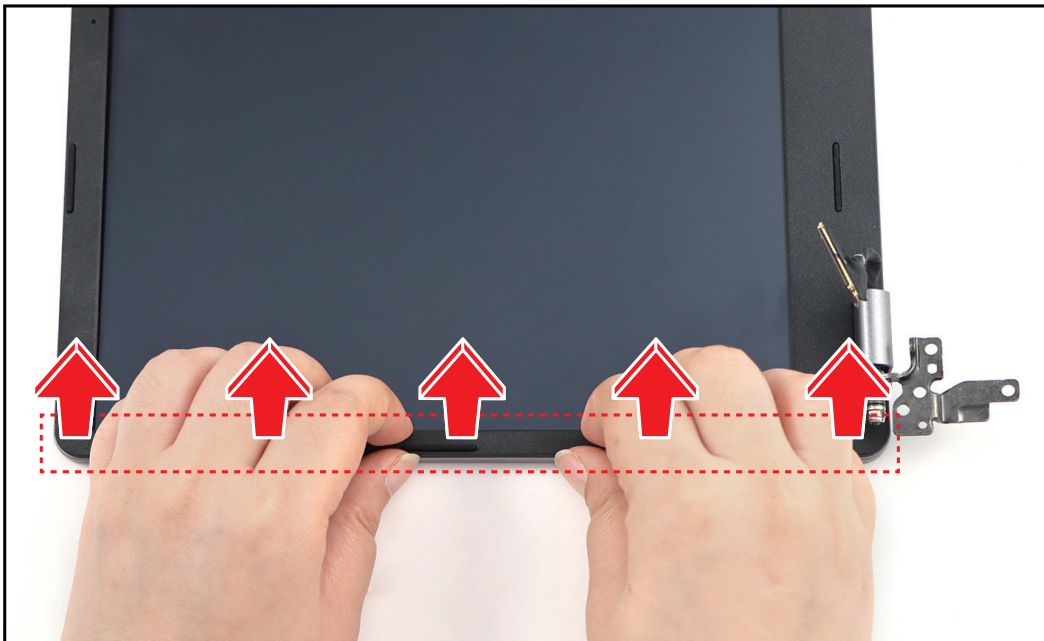

**Figure 1-41. Removing the LCD Bezel (3 of 4)**

5. Pry the bottom side latches. Then remove the LCD bezel.



**Figure 1-42. Removing the LCD Bezel (4 of 4)**



# LCD Panel Removal

## Prerequisite:

※ Hinge Caps Removal

1. Disconnect the eDP cable from the CMOS and dual microphone module connector and unroute the eDP cable from the upper cable guides.

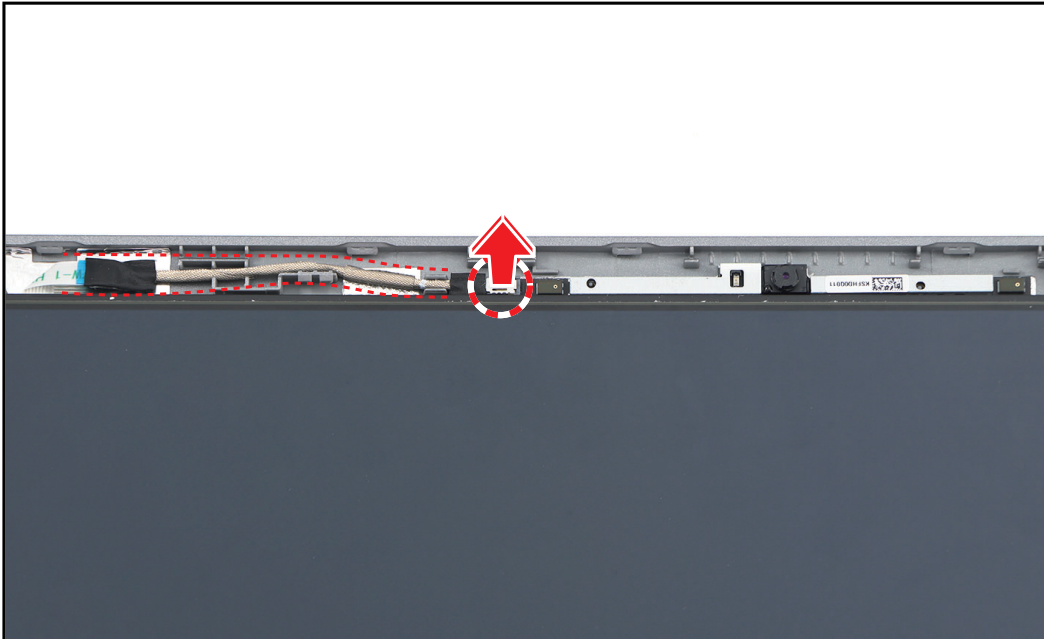

**Figure 1-43. Disconnecting and Unrouting the eDP Cable**

2. Remove ten (10) screws securing the LCD hinges in place.



**Figure 1-44. Removing the Screws**

3. Release the left and right LCD hinges from the guide pins and remove them from the LCD cover.

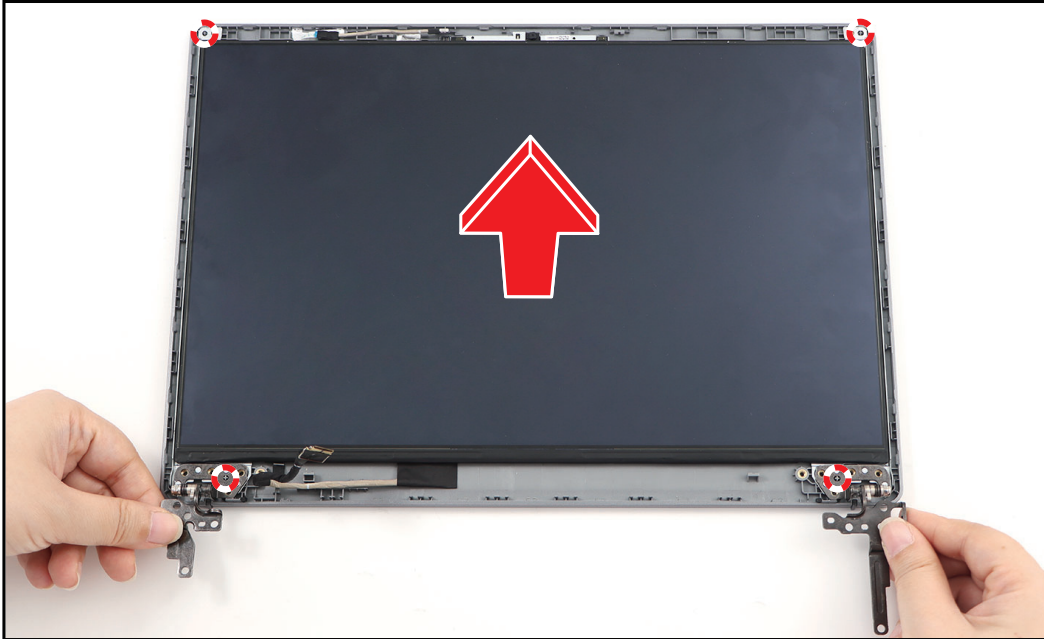

**Figure 1-45. Removing the LCD Hinges**

4. Pry slightly to access the double-sided mounting tape underneath the LCD panel. Then carefully pull to detach the double-sided mounting tape. Repeat the same procedure to remove the double-sided mounting tape on another side of the LCD panel.

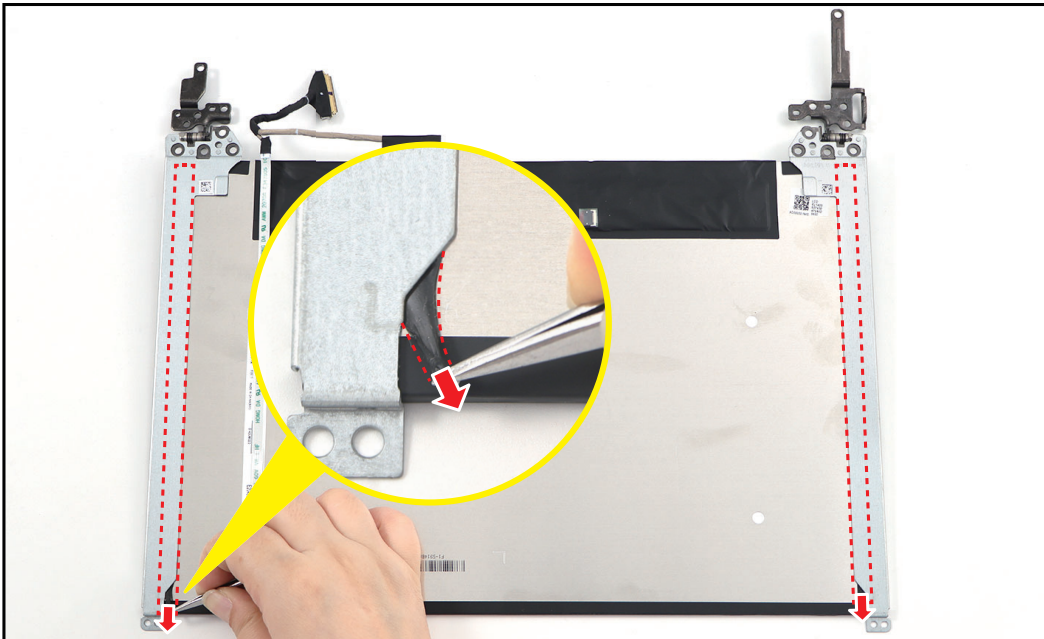

**Figure 1-46. Detaching the Double-sided Mounting Tapes**

5. Detach the eDP cable from the LCD panel and remove it.



**Figure 1-47. Removing the eDP Cable**

6. Carefully flip the LCD panel and detach the mylar securing the eDP cable to the LCD panel connector.

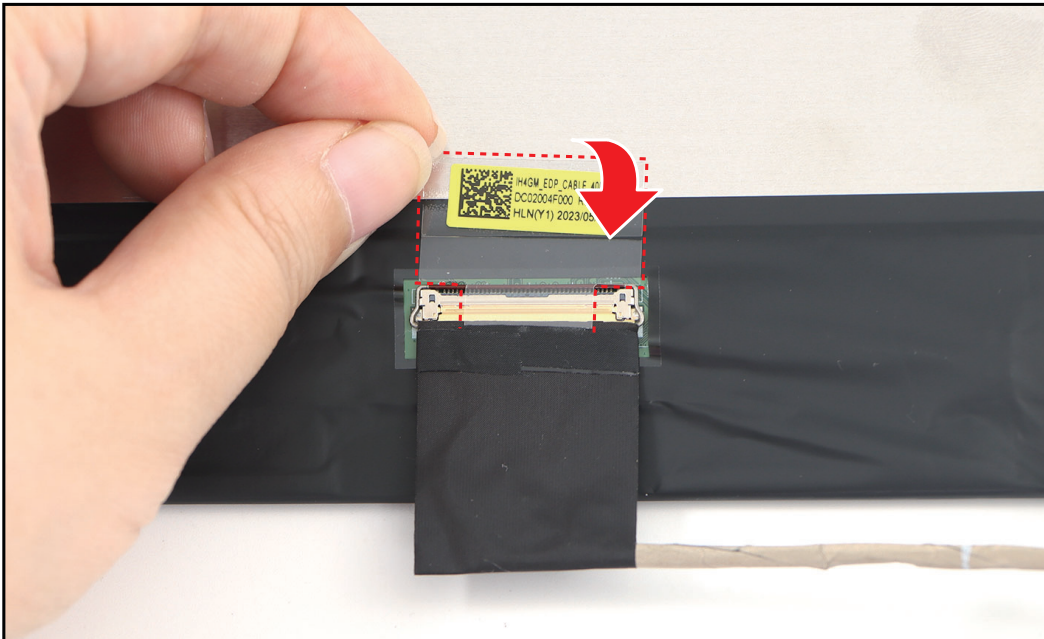

**Figure 1-48. Detaching the Mylar**

7. Lift to open the latch securing the eDP cable.

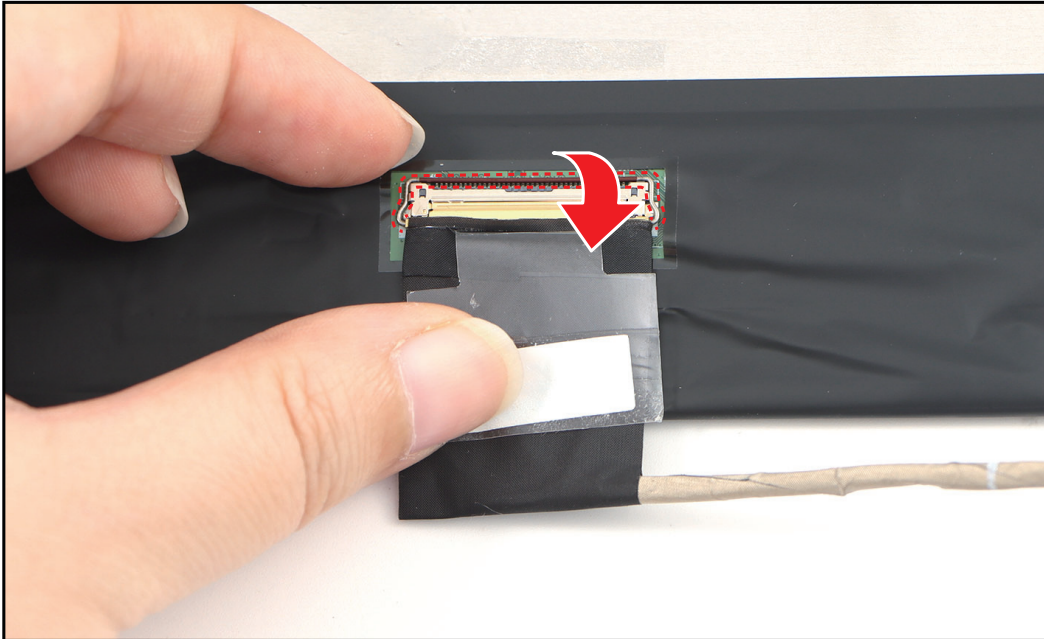

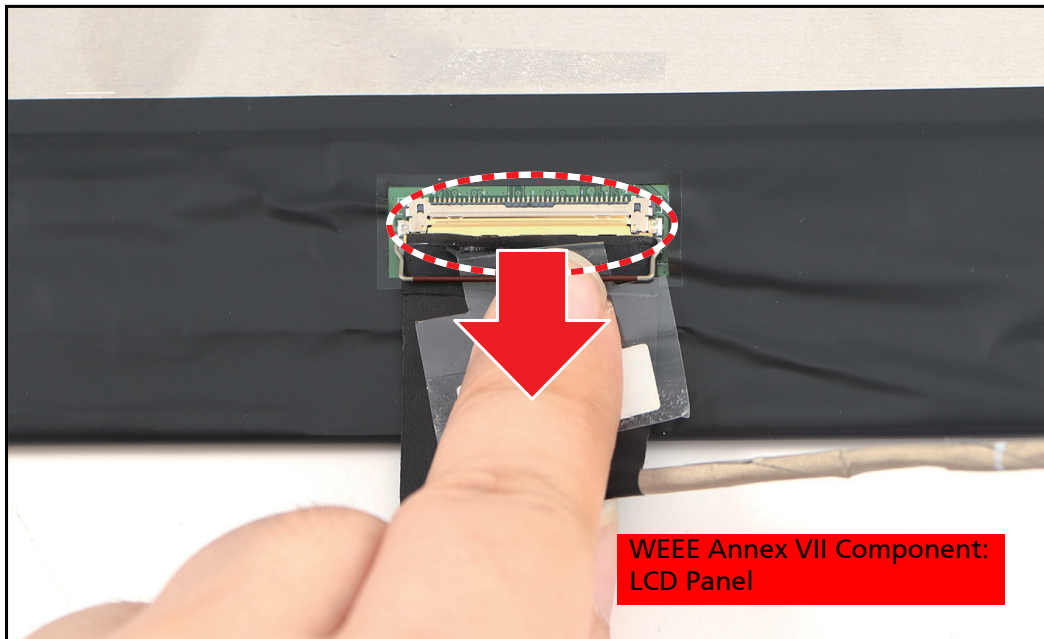

**Figure 1-49. Opening the Latch**

8. Disconnect the eDP cable from the LCD panel connector. Then remove the LCD panel.



**Figure 1-50. Disconnecting the eDP Cable**

**Table 1-9. LCD Hinges Screws**

<b>Screw Name</b>	<b>Screw Type</b>	<b>Torque</b>	<b>Quantity</b>
M 2.5 x 4.0		2.65~3.45kgf.cm	8
M 2.0 x 3.0		1.8~2.2kgf.cm	2

# Troubleshooting

---

This chapter shows you how to deal with common system problems. Read it before calling a technician if a problem occurs. Solutions to more serious problems require opening up the computer. Do not attempt to open the computer yourself; contact your dealer or authorized service center for assistance.

## Recover your Chromebook

When your Chromebook's operating system (OS) isn't working properly, you can recover it. Recovery is removing and reinstalling the OS.

### ⇒ NOTE:

If you're using your Chromebook at work or school, ask [your administrator](#) for help. Administrators: For more help, contact Google support.

## When to recover

You might want to recover if:

- You see this error message: "Chrome OS is missing or damaged".
- You've tried [other troubleshooting](#) steps and nothing has fixed your issue.
- You've asked the experts in our [help forum](#) for help fixing your issue, and they recommend recovery.

## What you need to get started

- The Chromebook with the "Chrome OS is missing or damaged" error.
- Another Chromebook, or a Windows or Mac computer with Chrome installed.
- A USB flash drive that can hold at least 8 GB, and that you don't mind erasing. If your Chromebook has an SD card slot, you can use an SD card instead.



### IMPORTANT:

Recovery permanently erases everything on your Chromebook's hard drive, including your downloaded files. If possible, [back up your files](#) before you recover your Chromebook.

## What you need to do

### Step 1: Try less invasive steps



If you can sign in to your Chromebook, try these steps first:

1. Turn your Chromebook off, then back on again.
2. If your Chromebook still has an error, [reset to factory settings](#).

If neither of those steps fix the error, continue to Step 2.



## Step 2: Download a new copy of the OS

On the working computer (not the Chromebook with the error):

1. If you're using a Mac or Windows computer:
  - a) If you haven't yet, [install Chrome](#).
  - b) Open **Chrome** .
  - c) Install the [recovery extension](#).
2. To open the recovery extension:
  - a) At the top right of your browser window, click **Extensions** .
  - b) To launch the extension popup, click on the "**Chromebook Recovery Utility**" extension. If the extension popup doesn't automatically appear on your screen, [make sure it's turned on](#).
3. Click **Get started**.
4. Click **Select** a model from a list, or type in the model number of the Chromebook you want to recover. To find this number, look at the bottom of the error message on your Chromebook screen.
5. Click **Continue**.
6. Insert your USB flash drive or SD card into the computer.
7. In the dropdown menu, choose the USB flash drive or SD card you inserted.
8. Click **Continue**.
9. Click **Create now**.
10. When you see a message saying that your recovery media is ready, remove the USB flash drive or SD card from the computer.



## Step 3: Enter recovery mode

On the Chromebook with the error:

1. If you have anything connected to this Chromebook (such as a mouse or external hard drive), remove it.
2. Enter recovery mode:
  - Chromebook: Press and hold **Esc + Refresh** , then press **Power** . Let go of **Power**. When a message shows on the screen, let go of the other keys.
  - Chromebox: First, turn it off. Using a paper clip or similar object, press and hold the [recovery button](#). Press the **Power** button to turn the Chromebox back on. When you see a message on screen, release the recovery button.
  - Chromebit: First, unplug it from power. Using a paper clip or similar object, press and hold the [recovery button](#). Plug the Chromebit back in to power. When you see a message on screen, release the recovery button.
  - Chromebook tablet: Press and hold the **Volume Up**, **Volume Down**, and **Power** buttons for at least 10 seconds, then release them.

3. You'll see one of these messages:
  - "Chrome OS is missing or damaged. Please insert a recovery USB stick or SD card."
  - "Please insert a recovery USB stick or SD card."
4. Insert the USB flash drive or SD card that you used to create recovery media.
5. Follow the on-screen instructions.



### **Make sure the recovery extension is turned on**

1. On your computer, open **Chrome** .
2. At the top right, click **Extensions**  > **Manage extensions**.
3. Next to "Chromebook Recovery," toggle the switch to the right.
4. Optional: You can also click **Details** and toggle the switch to the right.
5. Once the extension is on, in the extension panel in your browser, click on the extension to open the popup.
6. Optional: If you use the extension frequently, you can pin it .

### **Optional: Reuse your USB flash drive or SD card**

After recovering your Chromebook, you'll need to erase the recovery media if you want to reuse your USB flash drive or SD card to store other files.

To erase the recovery media:

1. On your computer, open **Chrome** .
2. At the top right, click **Extensions** .
3. To launch the extension popup, click on the "**Chromebook Recovery Utility**" extension.
4. In the extension popup, click **Settings** .
5. Click **Erase recovery media**.
6. From the dropdown menu, select the USB drive or SD card you'd like to erase.
7. Click **Continue**.
8. Make sure the storage device you used for recovery is listed.
9. Click **Erase now**.
10. The tool will erase everything on your USB drive or SD card. When you see the message "Your recovery media has been erased," click **Done**.
11. Remove the USB flash drive or SD card from the computer.
12. Format the storage device using a tool provided by your operating system.



## Fix problems with recovery

*“An unexpected error has occurred”.*

1. [Erase the storage device](#), then [try recovery again](#).
2. Try using a different USB flash drive or SD card to recover. Some USB flash drives and SD cards don't work well with recovery.

If you're still having problems, contact your Chromebook manufacturer for help.

[Learn how to contact your manufacturer](#).

*“Please remove all connected devices and start recovery”.*

First, remove anything that's connected to your Chromebook, such as a mouse, SD card or external hard drive. Then follow the steps to [enter recovery mode](#).

*“The device you inserted does not contain Chrome OS”.*

First, make sure that you inserted the USB drive or SD card that you used to create recovery media.

If you're using the correct storage device, but still see this error, the storage device might not be working properly.

1. [Erase the storage device](#), then [try recovery again](#).
2. Try using a different USB flash drive or SD card to recover. Some USB flash drives and SD cards don't work well with recovery.

If you're still having problems, contact your Chromebook manufacturer for help.

[Learn how to contact your manufacturer](#).

*“The security module on this device is not working”.*

First, ask our experts for help:

- “If you use your Chromebook at work or school, contact your administrator. Administrators: contact Google support.”
- “Chat with experts on the [Chromebook help forum](#).”

If you're still having problems, contact your manufacturer to repair your Chromebook.

[Learn how to contact your manufacturer](#).

# FRU (Field Replaceable Unit) List

---

Please contact your local service center to find out how to obtain the part or replace your device.

# Exploded Diagrams

## Main Assembly

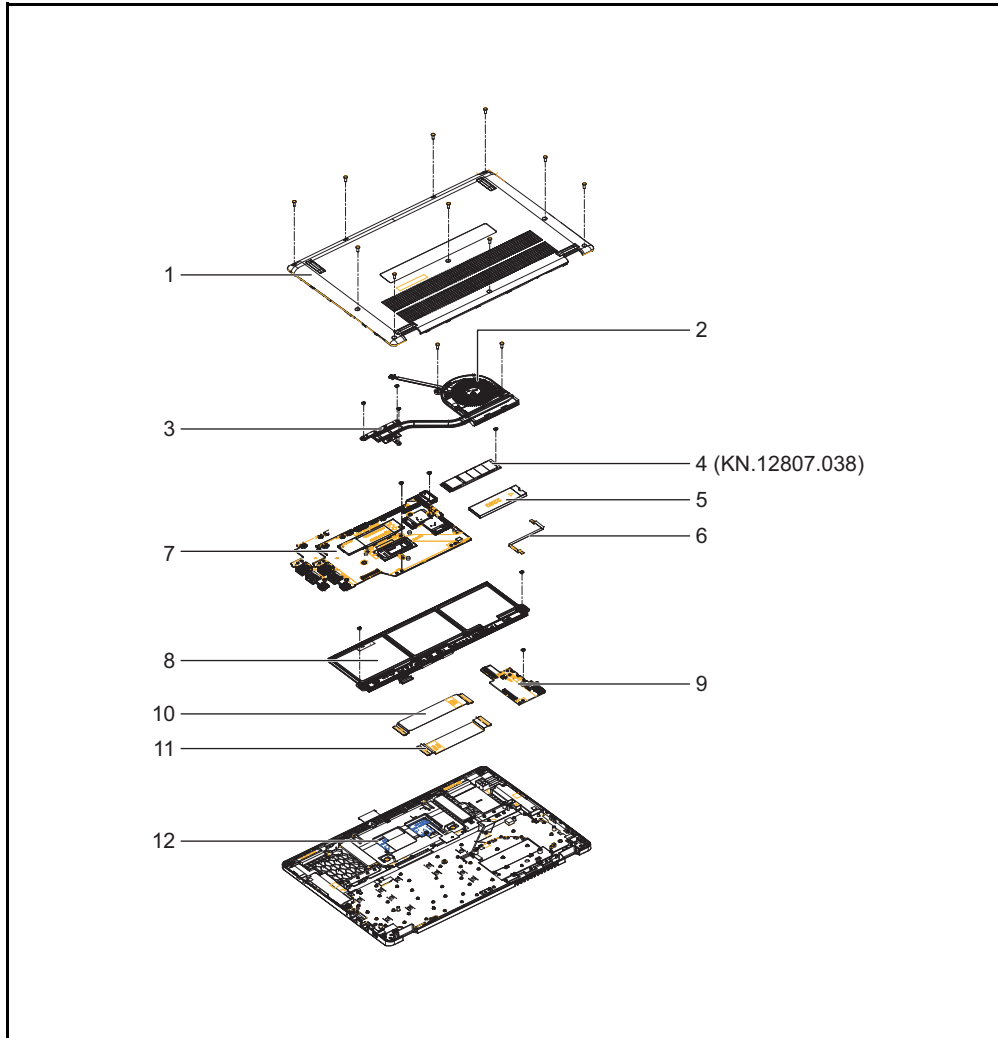

Figure 1-1. Main Assembly Exploded Diagram

Table 1-10. Main Assembly Exploded Diagram

No.	Acer Description	Acer P/N
1	Lower case	64.KP2N2.001
2	Fan module	23.KP2N2.001
3	Thermal module	24.KP2N2.001
4	SSD module	KN.12807.038
5	Foil shielding for SSD	47.B0QN2.004
6	Touchpad FFC	50.KP2N2.003

**Table 1-10. Main Assembly Exploded Diagram (Continued)**

<b>No.</b>	<b>Acer Description</b>	<b>Acer P/N</b>
7	Mainboard	NB.KP211.001
8	Battery pack	KT.0030B.004
9	USB board	55.KP2N2.001
10	USB board FFC	50.KP2N2.001
11	USB board FFC (high speed)	50.KP2N2.002
12	Keyboard	6B.KP4N2.001

# Upper Case Assembly

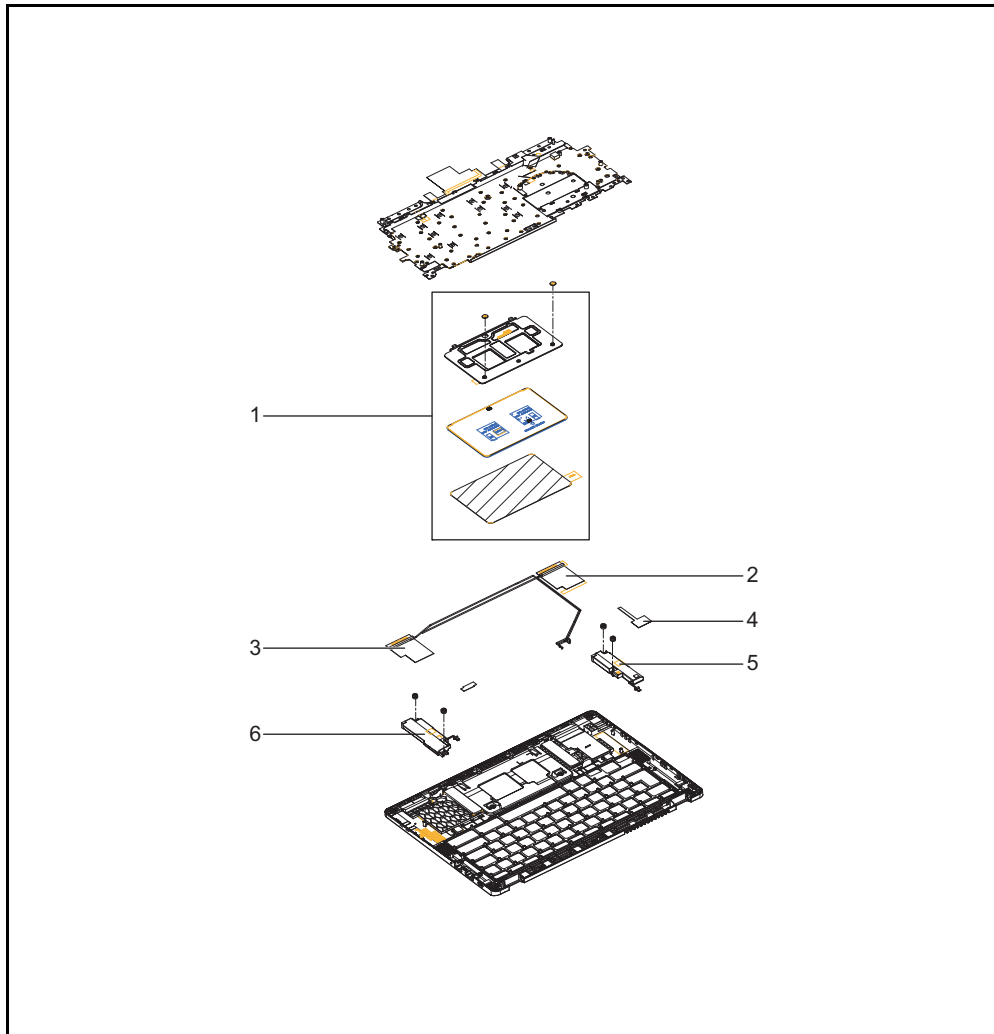
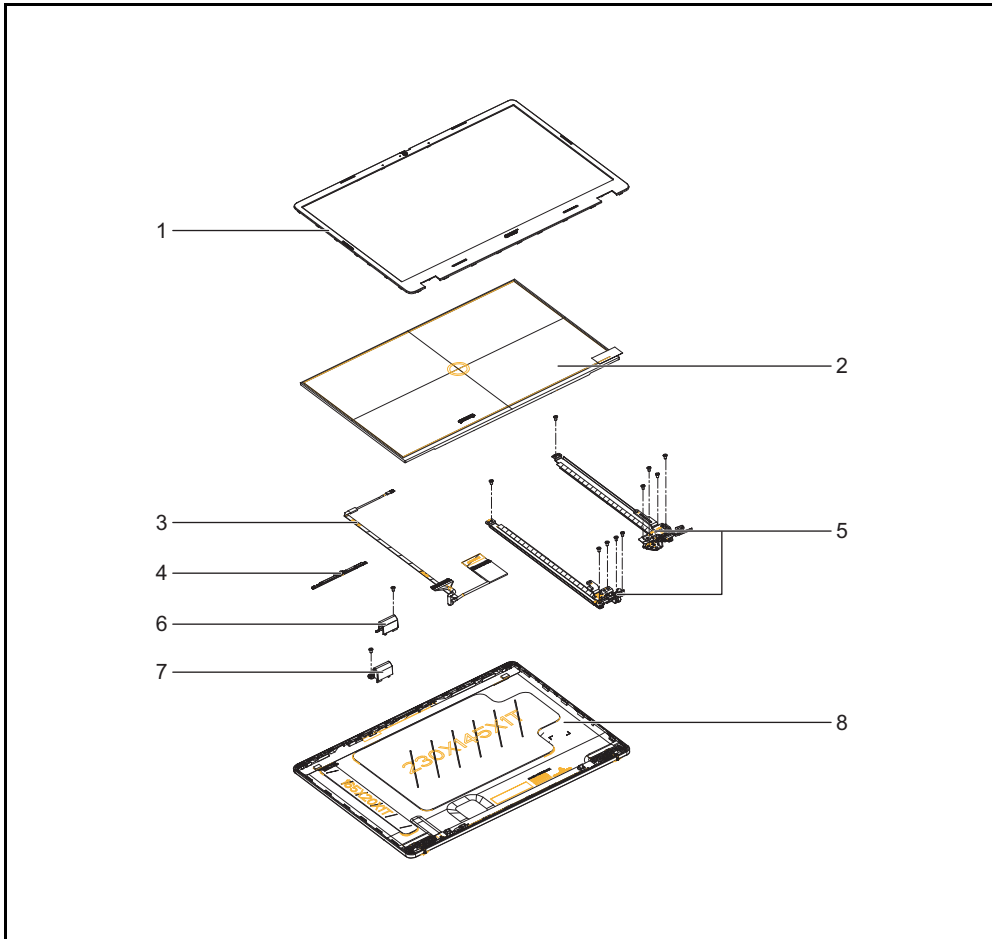

**Figure 1-2. Upper Case Assembly Exploded Diagram**

**Table 1-11. Upper Case Assembly Exploded Diagram**

No.	Acer Description	Acer P/N
1	Touchpad module	56.KP2N2.001
2	WLAN main antenna	50.KP2N2.004
3	WLAN aux antenna	50.KP2N2.005
4	Conductive tape for touchpad	47.KP2N2.001
5	Left speaker	23.KP2N2.002
6	Right speaker	23.KP2N2.003

# LCD Assembly



**Figure 1-3. LCD Assembly Exploded Diagram**

**Table 1-12. LCD Assembly Exploded Diagram**

No.	Acer Description	Acer P/N
1	LCD bezel	62.KP2N2.001
2	LCD panel	KL.14005.070
3	Edp cable	50.KP2N2.006
4	Camera module	KS.FHD0Q.011
5	Left LCD hinge bracket with adhesive	33.KP2N2.001
	Right LCD hinge bracket with adhesive	33.KP2N2.002
6	Right LCD hinge cap	42.KP2N2.002
7	Left LCD hinge cap	42.KP2N2.001
8	LCD cover	61.KP2N2.001

# Check for Updates Yourself

---

1. Turn on your Chromebook.
2. Connect your Chromebook to Wi-Fi.
3. At the bottom right, select the time.
4. Select **Settings** .
5. At the bottom of the left panel, select **About Chrome OS**.
6. Under "Google Chrome OS", you'll find which version of the Chrome operating system your Chromebook uses.
7. Select **Check for updates**.
8. If your Chromebook finds a software update, it will start to download automatically.

# Factory Reset Your Chromebook

---

1. Sign out of your Chromebook.
2. Press and hold **Ctrl + Alt + Shift + r**.
3. Select **Restart**.
4. In the box that appears, select **Powerwash > Continue**.
5. Follow the steps that appear and sign in with your Google Account.

**⇒ NOTE:**

The account you sign in with after you reset your Chromebook will be the owner account.