



Poly Partner Mode User Guide 4.1.0 (G7500, Studio X70, Studio X52, Studio X50, and Studio X30)

SUMMARY

This guide provides the end-user with task-based user information for the featured product.

Legal information

Copyright and license

© Copyright June 2023, HP Development Company, L.P. The information contained herein is subject to change without notice. The only warranties for HP products and services are set forth in the express warranty statements accompanying such products and services. Nothing herein should be construed as constituting an additional warranty. HP shall not be liable for technical or editorial errors or omissions contained herein.

Trademark credits

All third-party trademarks are the property of their respective owners. Google and the Google Logo are registered trademarks of Google LLC.

Privacy policy

Poly complies with applicable data privacy and protection laws and regulations. Poly products and services process customer data in a manner consistent with the Poly Privacy Policy. Please direct comments or questions to privacy@poly.com.

Open source software used in this product

This product contains open source software. You may receive the open source software from Poly up to three (3) years after the distribution date of the applicable product or software at a charge not greater than the cost to Poly of shipping or distributing the software to you. To receive software information, as well as the open source software code used in this product, contact Poly by email at open.source@poly.com.

Table of contents

| | |
|---|----------|
| 1 About this guide | 1 |
| Audience, Purpose, and Required Skills | 1 |
| Icons used in Poly documentation | 1 |
| 2 Getting Started | 2 |
| Poly Partner Mode Overview | 2 |
| Navigating Your System | 2 |
| Poly IR Remote Control Button Functions | 2 |
| Bluetooth Remote Control Button Functions | 3 |
| Enable TalkBack in Microsoft Teams Rooms | 5 |
| Navigating Talkback in Microsoft Teams Rooms | 5 |
| Using a Connected Trio in a Microsoft Teams Rooms Environment | 5 |
| Product Overview of Poly Video Systems | 6 |
| Poly G7500 System Features and Capabilities | 6 |
| Poly Studio X70 Features and Capabilities | 6 |
| Poly Studio X52 Features and Capabilities | 7 |
| Poly Studio X50 Features and Capabilities | 7 |
| Poly Studio X30 Features and Capabilities | 8 |
| Poly Studio E70 Camera Overview | 8 |
| Administrator Features and Capabilities | 9 |
| Overview of System Hardware | 9 |
| Poly G7500 Hardware | 9 |
| Poly G7500 System Ports | 9 |
| Poly Studio X70 Hardware | 10 |
| Poly Studio X70 System Hardware Ports | 11 |
| Poly Studio X70 Privacy Shutter Behavior | 12 |
| Poly Studio X52 Hardware | 12 |
| Poly Studio X52 System Ports | 13 |
| Poly Studio X52 Privacy Cover | 13 |
| Poly Studio X50 Hardware | 14 |
| Poly Studio X50 System Ports | 14 |
| Poly Studio X50 Privacy Cover | 15 |
| Poly Studio X30 Hardware | 16 |
| Poly Studio X30 System Ports | 16 |
| Poly Studio X30 Privacy Cover | 17 |
| Poly Studio E70 Camera Hardware | 17 |

| | |
|--|-----------|
| Poly Studio E70 Ports..... | 17 |
| Poly Studio E70 Privacy Shutter Behavior..... | 18 |
| LED Status Indicators | 19 |
| LED Status Indicators for the G7500 System | 19 |
| LED Status Indicators for the Studio X70 System | 19 |
| LED Status Indicators for Studio X50, and Studio X30 Systems | 20 |
| LED Status Indicators for the Studio E70 Camera..... | 21 |
| Powering the System On and Off..... | 21 |
| Wake the System | 21 |
| Accessibility Features | 22 |
| Users Who Are Deaf or Hard of Hearing | 22 |
| Users Who Are Blind, Have Low Vision, or Have Limited Vision..... | 22 |
| Users with Limited Mobility | 22 |
| 3 Sharing Content | 24 |
| Share Content Using an HDMI Connection | 24 |
| 4 Using Device Mode | 25 |
| Computer and Cable Requirements for Device Mode | 25 |
| Access Device Mode..... | 25 |
| Use Your System as a Computer Accessory | 26 |
| Adjust the System Audio and Camera Settings in Device Mode | 26 |
| Managing Incoming Calls When in Device Mode | 27 |
| Exit Device Mode and Disconnect Your Computer | 27 |
| 5 Settings | 28 |
| Cameras..... | 28 |
| Adjust an In-Room Camera | 28 |
| Turn Camera Tracking On or Off | 28 |
| Audio Adjustments | 29 |
| Adjust the Volume..... | 29 |
| 6 Troubleshooting..... | 30 |
| Poly Device Mode | 30 |
| Audio Levels are Too High or Low..... | 30 |
| Conferencing Application Doesn't Use System Camera or Audio | 30 |
| Can't Use System's Camera or Audio | 30 |
| Improve Audio Quality..... | 31 |
| Improve Laptop Screen Mirroring | 31 |
| 7 Getting help | 32 |

1 About this guide





This section provides clarifying information about this guide.

Audience, Purpose, and Required Skills

This guide is intended for beginning users, as well as intermediate and advanced users who want to learn how to use the features available with Poly Trio.

Icons used in Poly documentation

This section describes the icons used in Poly Documentation and what they mean.

-
-  **WARNING!** Indicates a hazardous situation that, if not avoided, **could** result in serious injury or death.
 -  **CAUTION:** Indicates a hazardous situation that, if not avoided, **could** result in minor or moderate injury.
 -  **IMPORTANT:** Indicates information considered important but not hazard-related (for example, messages related to property damage). Warns the user that failure to follow a procedure exactly as described could result in loss of data or in damage to hardware or software. Also contains essential information to explain a concept or to complete a task.
 -  **NOTE:** Contains additional information to emphasize or supplement important points of the main text.
 -  **TIP:** Provides helpful hints for completing a task.
-

2 Getting Started

Before you use your system, familiarize yourself with its features and local interface.

Poly Partner Mode Overview

Poly Partner Mode allows you to run third-party conferencing applications on supported Poly video systems. For example, after powering on your system for the first time, you can select Zoom Rooms to place Zoom calls.



NOTE: Not all providers are supported on all systems. For the latest information on partner applications supported on each system, see the *Poly VideoOS Release Notes*.

Refer to the supported partner documentation for information on using third-party applications:

- **Microsoft Teams Rooms:** <https://support.office.com/en-us/teams>
- **Zoom Rooms:** <https://support.zoom.us/hc/en-us>
- **Google Meet:** <https://apps.google.com/meet/>
- **BlueJeans Rooms by Verizon:** <https://support.bluejeans.com/s/>
- **Dialpad:** <https://help.dialpad.com/>
- **GoToRoom by LogMeIn:** <https://support.goto.com/products>
- **RingCentral Rooms (RCV Rooms):** <https://support.ringcentral.com/>
- **Tencent:** <https://meeting.tencent.com/cloud-rooms.html>

Navigating Your System

The system has icons and user screens to help you navigate and understand important information about your system.

Poly IR Remote Control Button Functions

When you connect a Poly IR receiver to your G7500 or Studio X system, you can use the Poly IR remote control to navigate your system.



NOTE: Remote control functionality may be limited in other partner applications.

The following illustration and table show the buttons and functionality of the Poly IR remote control.

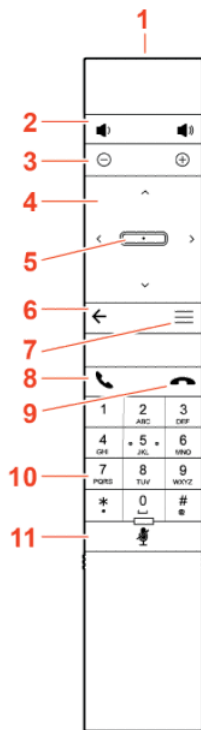

Table 2-1 IR Remote Button Functions

| Item | Description | Function |
|------|---------------------|--|
| 1 | IR LED | Sends IR signals to the IR receiver |
| 2 | Volume | Increase or decrease the volume |
| 3 | Camera zoom | Zoom the camera in or out |
| 4 | Navigation controls | Navigate the user interface. |
| 5 | Select | Select an item on the user interface or adjust a toggle |
| 6 | Back arrow | Return to the previous screen |
| 7 | Menu | In Poly Video mode only, show or hide the settings and camera controls |
| 8 | Call | Display the calls screen or answer an incoming call |
| 9 | End call | End an active call or reject an incoming call |
| 10 | Dialpad | Dial a number |
| 11 | Mute | Mute or unmute the system microphones |

Bluetooth Remote Control Button Functions

When you pair the Poly Bluetooth remote control with your G7500 or Studio X system, you can use the remote control to navigate your system.



NOTE: Remote control functionality may be limited in other partner applications.

The following illustration and table show the buttons and functionality of the Bluetooth remote control. The functionality is specific to Poly Video mode.

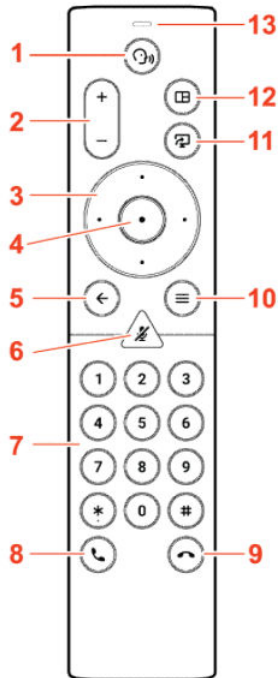



Table 2-2 IR Remote Button Functions

| Item | Description | Function |
|------|---------------------|--|
| 1 | Voice Assistant | Feature planned for future use |
| 2 | Volume or zoom | Adjust volume up and down or, in camera mode, zoom the camera in or out |
| 3 | Navigation controls | Navigate the screen In camera mode, controls camera pan and tilt |
| 4 | Select | Select an item on the user interface or adjust a toggle |
| 5 | Back arrow | Return to the previous screen |
| 6 | Mute | Mute the system microphones. Long press to pair the remote control with the system |
| 7 | Keypad | Dial a number. Select camera presets while in a call in |
| 8 | Call button | Display the calls screen or answer an incoming call |
| 9 | End call | End an active call, reject an incoming call, or end a meeting |
| 10 | Menu | Open the available system menu to access features |
| 11 | Present content | From the home screen, display the content help screen In a meeting, open the content tray and select available content to share |

Table 2-2 IR Remote Button Functions (continued)

| Item | Description | Function |
|------|----------------------------|---|
| 12 | Layout | Open the layout screen to choose how two or more participants display on the screen |
| 13 | Voice Assistant Microphone | Feature planned for future use |

Enable TalkBack in Microsoft Teams Rooms

 **NOTE:** Talkback is disabled by default. If the device restarts, you'll need to reenable Talkback.

1. On the touch controller, select **More > Settings > Device Settings > Accessibility**.
2. Enable **Talkback**.

Navigating Talkback in Microsoft Teams Rooms

Navigate the user interface by touch using a menu of available gestures. As you navigate the screen, the device announces the item you select.

 **NOTE:** Items in the **Settings** menu may appear below the screen. To access items below the screen, use two fingers to scroll up or swipe right on the screen to go down the list.

Talkback Navigation

| Touch Gesture | Result |
|-----------------------------------|--|
| Swipe right | Moves to the next user interface element and announces the element name |
| Swipe left | Moves to the previous user interface element and announces the element name |
| Drag one finger around the screen | Speaks the name of the user interface item or the onscreen text as your finger moves over it |
| Double tap the screen | Selects the user interface item currently in focus |
| Swipe down then left | Returns to the main screen |
| Swipe up or down and right | Opens the Talkback menu |
| Swipe up or down with two fingers | Scrolls through menu items |
| Swipe down then left | Return to the main screen |

Using a Connected Trio in a Microsoft Teams Rooms Environment

Your Microsoft Teams Rooms solution may include one or two connected Poly Trio speakerphones. The Poly Trio speakerphones are used as external speakers and microphones for your system.

From a connected Poly Trio in Microsoft Teams Rooms mode, you can:

- Mute or unmute the microphones
- Adjust the call volume

Product Overview of Poly Video Systems

Poly G7500, Studio X70, Studio X52, Studio X50, and Studio X30 systems in Poly Video Mode support Poly video conferencing and content sharing features.

Poly G7500 System Features and Capabilities

G7500 systems support the following features:

- Peripheral cameras and microphones make the system scalable for medium rooms and up to large integrated rooms
- Placing and joining video calls
- Sharing wireless and wired content
- Camera tracking technology that can automatically zoom in on the person talking or frame the group of people in the room (depending on the paired camera and system configuration)
- Poly NoiseBlockAI, which eliminates background and extraneous sound during calls in common working environments
- Polycom Acoustic Fence technology, which enables video conferencing in open workspaces by capturing only the voices in a defined area
- HDMI: Single input and dual output
- Using a wired or wireless USB mouse as an input device

Poly Studio X70 Features and Capabilities

Poly Studio X70 Features and Capabilities

Studio X70 systems support the following features:

- All-in-one collaboration system for medium-to-large rooms
- No need for a separate PC, laptop, or codec to run video-conferencing software
- Placing and joining video calls
- Sharing wireless and wired content
- Dual built-in 4K cameras
- Camera tracking technology that automatically frames the group of people in the room
- Hi-fidelity, built-in stereo microphones that pick up sound within 7.62 m (25 ft) and use spatial audio for life-like presence and clarity
- Poly NoiseBlockAI, which eliminates background and extraneous sound during calls in common working environments
- HDMI: Single input and dual output
- Using a wired or wireless USB mouse as an input device

Poly Studio X70 Mounting Orientation

You can mount the Studio X70 above or below a display. The Studio X70 doesn't support inverted mounting. For information on mounting the Studio X70, see the Studio X70 setup sheet.

Poly Studio X52 Features and Capabilities

Studio X52 systems support the following features:

- All-in-one collaboration system for huddle rooms and small-to-medium rooms
- No need for a separate PC, laptop, or codec to run video-conferencing software
- Placing and joining video calls
- Sharing wireless and wired content
- Sharp 4K, 20MP camera with 95-degree horizontal field of view
- Camera tracking technology that automatically frames the group of people in the room
- Hi-fidelity, built-in stereo microphones that pick up sound within 7.62 m (25 ft) and use spatial audio for life-like presence and clarity
- Poly NoiseBlockAI, which eliminates background and extraneous sound during calls in common working environments
- Dual stereo speakers
- HDMI: Single input and dual output
- Simple to set up, manage, and use with Poly Lens

Poly Studio X52 Mounting Orientation

You can mount the Studio X52 above or below a display. The Studio X52 doesn't support inverted mounting. For information on mounting the Studio X52, see the *Poly Studio X52 Quick Start Guide*.

Poly Studio X50 Features and Capabilities

Studio X50 systems support the following features:

- All-in-one collaboration system for huddle rooms and small-to-medium rooms
- No need for a separate PC, laptop, or codec to run video-conferencing software
- Placing and joining video calls
- Sharing wireless and wired content
- Built-in 4K camera with ultra-wide 120-degree field of view
- Camera tracking technology that automatically frames the group of people in the room
- Hi-fidelity, built-in stereo microphones that pick up sound within 7.62 m (25 ft) and use spatial audio for life-like presence and clarity
- Poly NoiseBlockAI, which eliminates background and extraneous sound during calls in common working environments

- Dual stereo speakers
- HDMI: Single input and dual output
- Using a wired or wireless USB mouse as an input device

Poly Studio X50 Mounting Orientation

You can mount the Studio X50 above or below a display. The Studio X50 doesn't support inverted mounting. For information on mounting the Studio X50, see the Studio X50 setup sheet.

Poly Studio X30 Features and Capabilities

Studio X30 systems support the following features:

- All-in-one collaboration system for huddle rooms and small-to-medium rooms
- No need for a separate PC, laptop, or codec to run video-conferencing software
- Placing and joining video calls
- Sharing wireless and wired content
- Built-in 4K camera with ultra-wide 120-degree field of view
- Camera tracking technology that automatically frames the group of people in the room
- High-fidelity, built-in stereo microphones that pick up sound within 4.57 m (15 ft) and use spatial audio for life-like presence and clarity
- Poly NoiseBlockAI, which eliminates background and extraneous sound during calls in common working environments
- Single mono speaker
- HDMI: Single input and output
- Using a wired or wireless USB mouse as an input device

Poly Studio X30 Mounting Orientation

You can mount the Studio X30 above or below a display. The Studio X30 supports inverted mounting. For information on mounting the Studio X30, see the Studio X30 setup sheet.

Poly Studio E70 Camera Overview

Poly Studio E70 is a dual-camera solution supported on Poly G7500, Studio X70, Studio X52, and Studio X50 systems.

The Poly Studio E70 includes the following features:

- Standalone USB 4K camera with full tracking and framing capabilities
- Visual coverage up to 7.6 m (25 ft)
- Microphones that provide accurate sound source location to support camera tracking

Administrator Features and Capabilities

The G7500 and Studio X Family systems provide features for administrators to deploy, manage, and access systems.

These systems provide the following features and capabilities:

- Remote access for managing standalone systems
- Provisioning with Poly Clariti Manager to support single system, small business, and large multisite enterprise deployments
- SNMP reporting and remote logging
- Industry-standard security techniques, including 802.1X authentication

Overview of System Hardware

The figures and tables in the following topics provide information about hardware features available on your system.

Poly G7500 Hardware

The following figure displays the hardware features on the Poly G7500 system. The table lists each feature numbered in the figure.

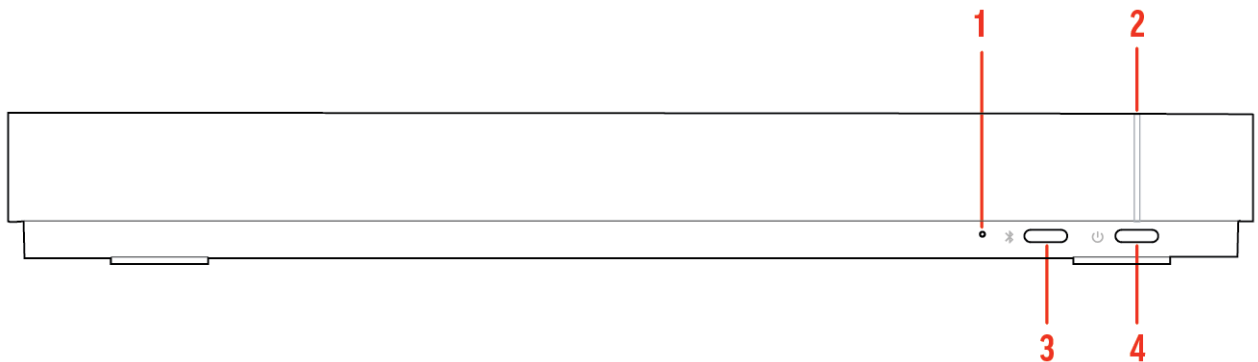

Table 2-3 Poly G7500 Feature Descriptions

| Ref. Number | Feature | Feature Description |
|-------------|-------------------------------|---|
| 1 | Reset button | Resets the Poly G7500 to the factory software version |
| 2 | LED indicator | Indicates the system status |
| 3 | Remote control pairing button | Enables the Bluetooth remote control pairing mode |
| 4 | Restart button | Restarts your system |

Poly G7500 System Ports

The following illustration and table explain the ports on the back panel of your G7500 system.

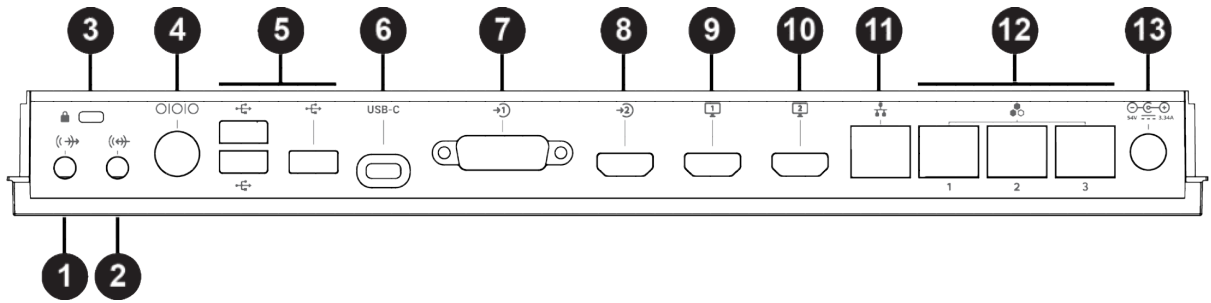

Table 2-4 G7500 System Port Descriptions

| Ref. Number | Port Description |
|-------------|--|
| 1 | 3.5 mm audio line out |
| 2 | 3.5 mm audio line in |
| 3 | Security lock |
| 4 | Mini-DIN/RS-232 serial port NOTE: The serial port is occasionally used by third party control system devices for automation. |
| 5 | USB-A ports |
| 6 | USB-C port |
| 7 | HDCI input for Polycom cameras |
| 8 | HDMI input for sharing content (for example, from a laptop) |
| 9 | HDMI output for the primary monitor |
| 10 | HDMI output for the secondary monitor |
| 11 | LAN connection for the system |
| 12 | Link-local network (LLN) connections for IP-based peripheral devices |
| 13 | Power cord port |

Poly Studio X70 Hardware

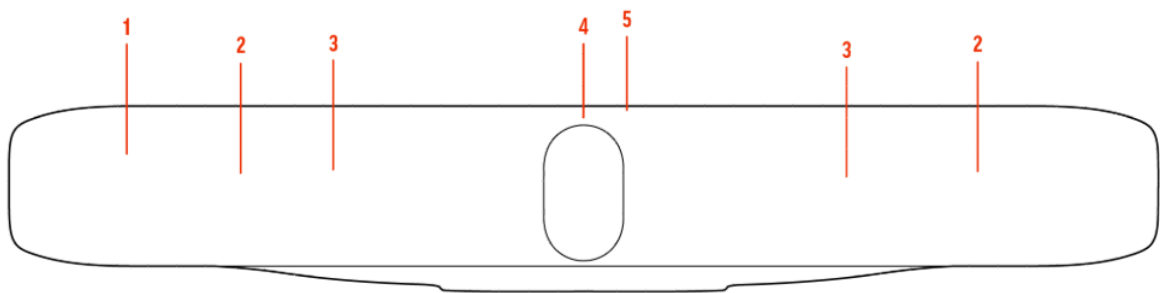

Table 2-5

| Ref. Number | Feature | Description |
|-------------|---------|---|
| 1 | Screen | Protective screen that covers the front of the system |

Table 2-5 (continued)

| Ref. Number | Feature | Description |
|-------------|------------------|---|
| 2 | Microphone array | Microphone array that captures audio |
| 3 | Speakers | Stereo audio output |
| 4 | Dual cameras | Camera array with a privacy shutter that automatically opens or closes, depending on the camera state |
| 5 | LED indicators | Indicates the system status and information on the tracked speaker |

Poly Studio X70 System Hardware Ports

The following illustration and table explain the hardware ports on your Poly Studio X70 system.

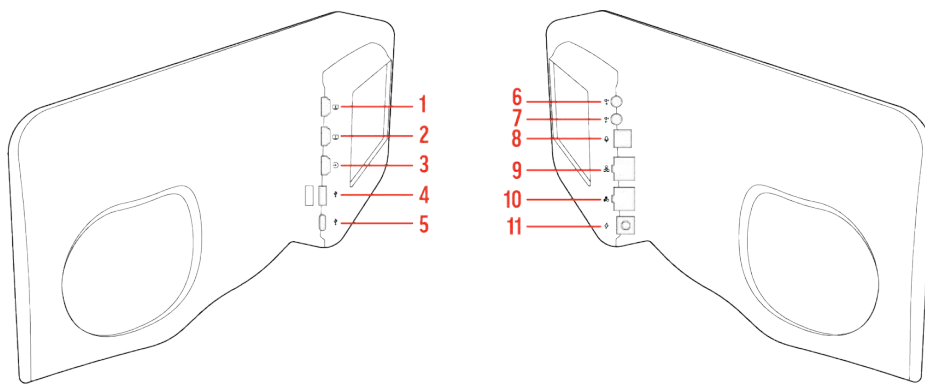

Table 2-6 Poly Studio X70 System Hardware Port Descriptions

| Ref. Number | Port Description |
|-------------|--|
| 1 | HDMI output for the secondary monitor |
| 2 | HDMI output for the primary monitor |
| 3 | HDMI input for sharing content (for example, from a laptop) |
| 4 | USB-A ports |
| 5 | USB-C port |
| 6 | 3.5 mm audio line in |
| 7 | 3.5 mm audio line out |
| 8 | Expansion microphone connection |
| 9 | LAN connection for the system |
| 10 | Link-local network (LLN) connections for IP-based peripheral devices NOTE: This port is disabled and is reserved for future use. |
| 11 | Power cord port |

Poly Studio X70 Privacy Shutter Behavior

The privacy shutter automatically opens and closes depending on the state of the connected video system.

Poly Studio X70 Privacy Shutter Behavior



NOTE: Shutter behavior may vary depending on the partner application.

| System Event | Shutter Behavior |
|---|--|
| The system powers on | Shutters open |
| The system powers off | Shutters close NOTE: If you remove power immediately, the shutters don't close. |
| The system enters sleep mode or digital signage starts and the Camera Sleep Setting is set to Save Energy | Shutters close |
| The system enters sleep mode or digital signage starts and Camera Sleep Setting is set to Fast Wake | Shutters remain open NOTE: When Fast Wake is set, the shutters never close. |
| You wake the system | Shutters open |
| You wake the system and the Studio X70 built-in camera isn't the primary camera | Shutters remain closed |
| You select the Studio X70 built-in camera as the primary camera | Shutters open |
| The system receives an incoming call | If the shutters are closed, they remain closed until the call is answered |
| The system is sending video | Shutters are open |
| The system is in an active call and the video is muted | Shutters are open |

Poly Studio X52 Hardware

The following figure displays the hardware features on the Poly Studio X52 system. The table lists each feature numbered in the figure.

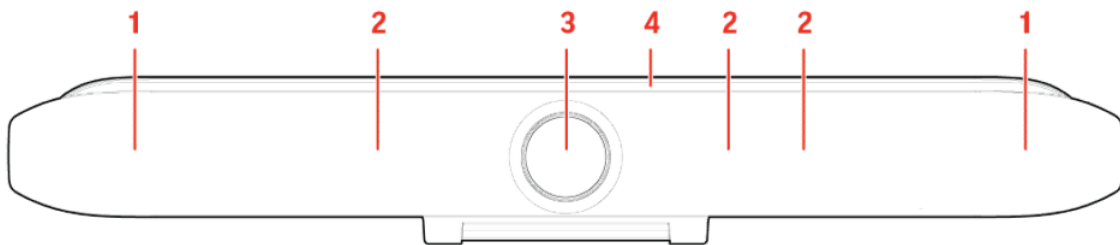

Table 2-7 Poly Studio X52 Feature Descriptions

| Ref. Number | Feature | Feature Description |
|-------------|------------------|--------------------------------------|
| 1 | Speaker | Stereo audio output |
| 2 | Microphone array | Microphone array that captures audio |

Table 2-7 Poly Studio X52 Feature Descriptions (continued)

| Ref. Number | Feature | Feature Description |
|-------------|----------------|--|
| 3 | Camera | Camera with a privacy cover that enables or disables the video input as you choose |
| 4 | LED indicators | Indicates the system status and information on the tracked speaker |

Poly Studio X52 System Ports

The following illustration and table explain the ports on your Poly Studio X52 system.

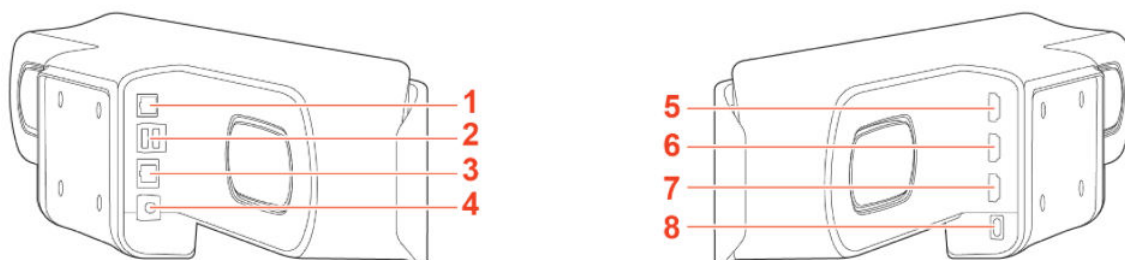
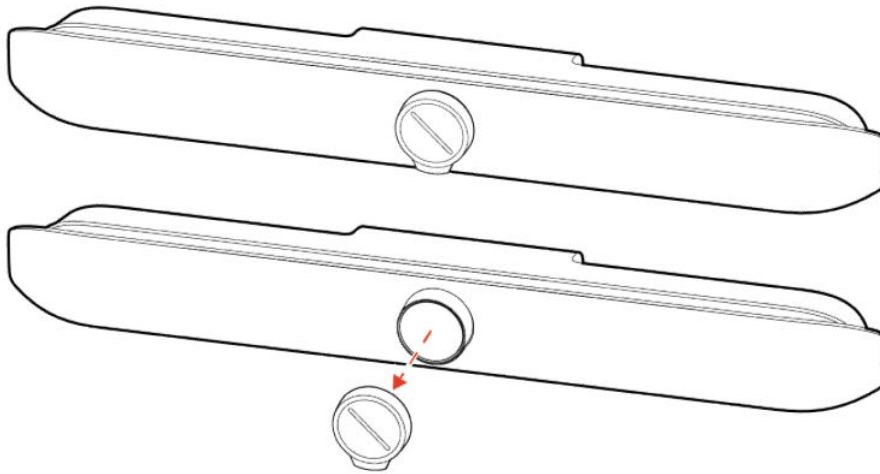

Table 2-8 Poly Studio X52 System Port Descriptions

| Ref. Number | Port Description |
|-------------|---|
| 1 | Poly Table Expansion Microphone connection |
| 2 | USB-A ports |
| 3 | RJ45 Ethernet port |
| 4 | Power port |
| 5 | HDMI port for secondary monitor |
| 6 | HDMI port for primary monitor |
| 7 | HDMI port for content sharing and Device Mode |
| 8 | USB-C port for Device Mode |

Poly Studio X52 Privacy Cover

The Poly Studio X52 system provides a physical cover that you can place over the camera lens to protect your privacy.



Poly Studio X50 Hardware

The following figure displays the hardware features on the Poly Studio X50 system. The table lists each feature numbered in the figure.

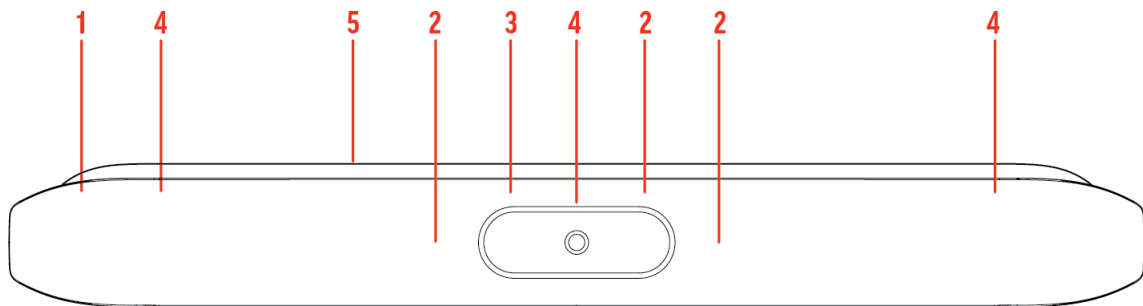

Table 2-9 Poly Studio X50 Feature Descriptions

| Ref. Number | Feature | Feature Description |
|-------------|------------------|--|
| 1 | Screen | Protective screen that covers the front of your system |
| 2 | Microphone array | Microphone array that captures audio |
| 3 | Camera | Camera with a privacy cover that enables or disables the video input as you choose |
| 4 | Speakers | Stereo audio output |
| 5 | LED indicators | Indicates the system status and information on the tracked speaker |

Poly Studio X50 System Ports

The following illustration and table explain the ports on your Poly Studio X50 system.

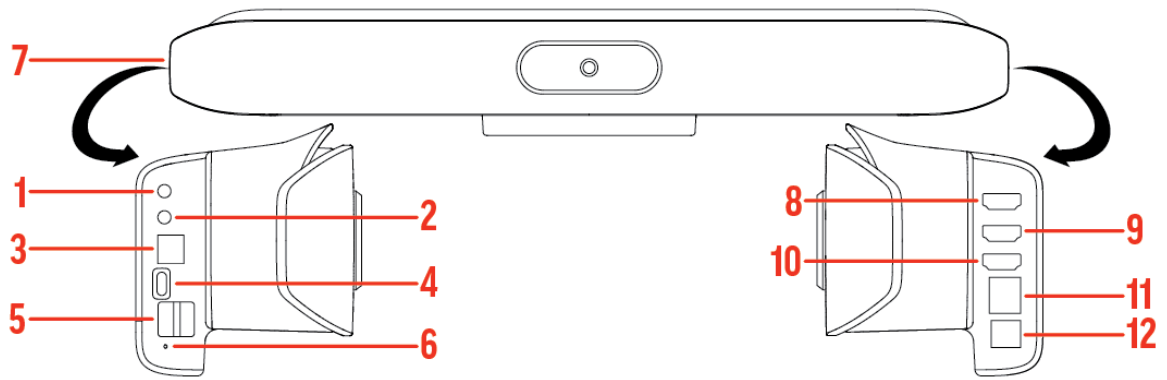
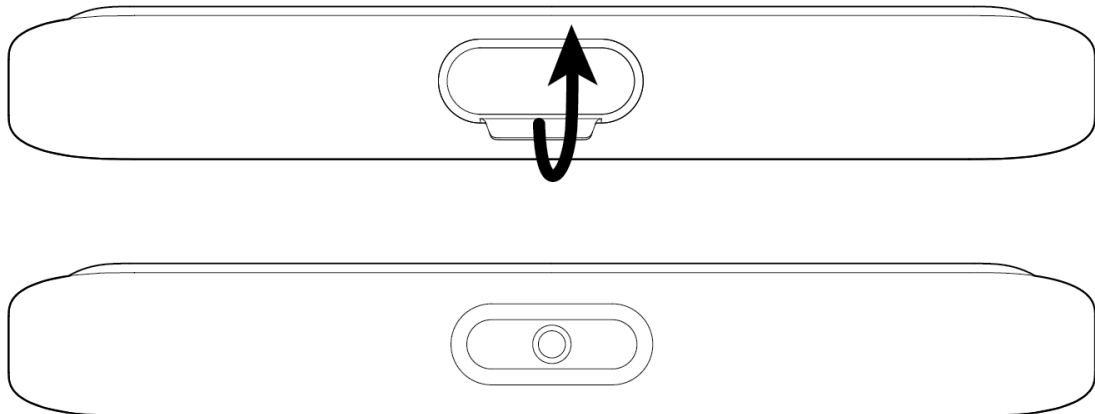

Table 2-10 Poly Studio X50 System Port Descriptions

| Ref. Number | Port Description |
|-------------|---|
| 1 | 3.5 mm audio line in |
| 2 | 3.5 mm audio line out |
| 3 | Polycom RealPresence Debut expansion microphone connection |
| 4 | USB-C port |
| 5 | USB-A ports |
| 6 | Factory restore pinhole |
| 7 | Security lock (on the back flat section of the system) |
| 8 | HDMI output for the secondary monitor |
| 9 | HDMI output for the primary monitor |
| 10 | HDMI input for sharing content (for example, from a laptop) |
| 11 | LAN connection for the system |
| 12 | Power cord port |

Poly Studio X50 Privacy Cover

The Poly Studio X50 provides a physical cover that you can place over the camera lens to protect your privacy.



Poly Studio X30 Hardware

The following figure displays the hardware features on the Poly Studio X30 system. The table lists each feature numbered in the figure.

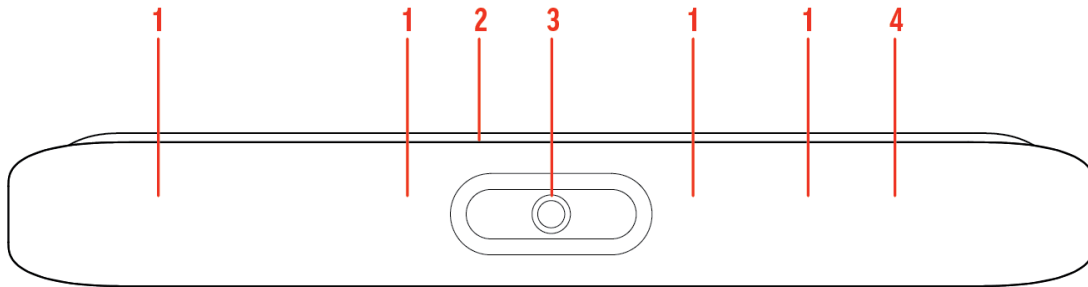

Table 2-11 Poly Studio X30 Feature Descriptions

| Ref. Number | Feature | Feature Description |
|-------------|------------------|--|
| 1 | Microphone array | Microphone array that captures audio |
| 2 | LED indicators | Indicates the system status and information on the tracked speaker |
| 3 | Camera | Camera with a privacy cover that enables or disables the video input as you choose |
| 4 | Speaker | Mono audio output |

Poly Studio X30 System Ports

The following illustration and table explain the ports on your Poly Studio X30 system.

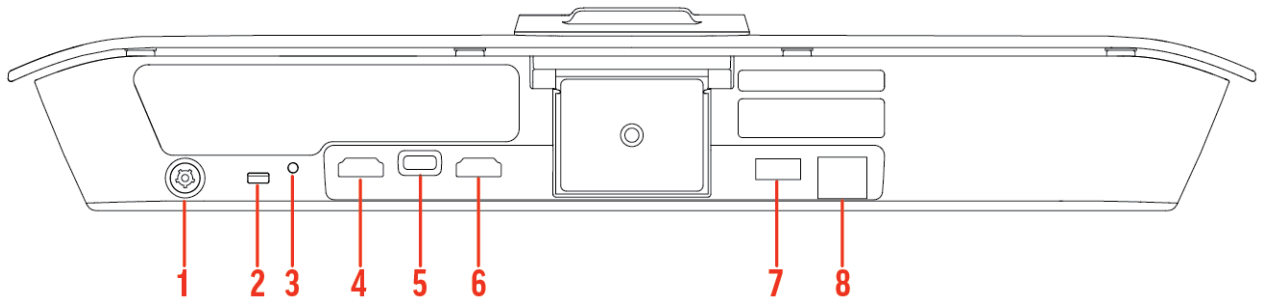
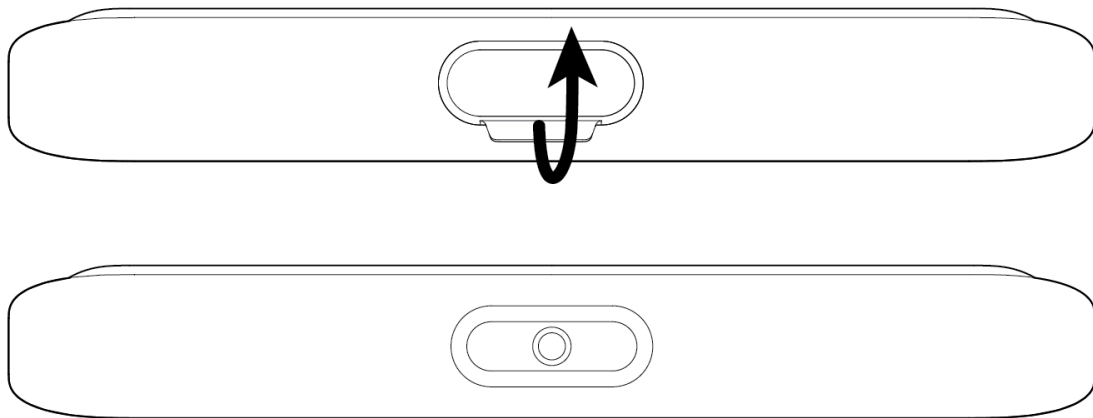

Table 2-12 Poly Studio X30 System Port Descriptions

| Ref. Number | Port Description |
|-------------|---|
| 1 | Power cord port |
| 2 | Security lock |
| 3 | Factory restore pinhole |
| 4 | HDMI output for the primary monitor |
| 5 | USB-C port |
| 6 | HDMI input for sharing content (for example, from a laptop) |
| 7 | USB-A ports |
| 8 | LAN connection for the system |

Poly Studio X30 Privacy Cover

The Poly Studio X30 provides a physical cover that you can place over the camera lens to protect your privacy.



Poly Studio E70 Camera Hardware

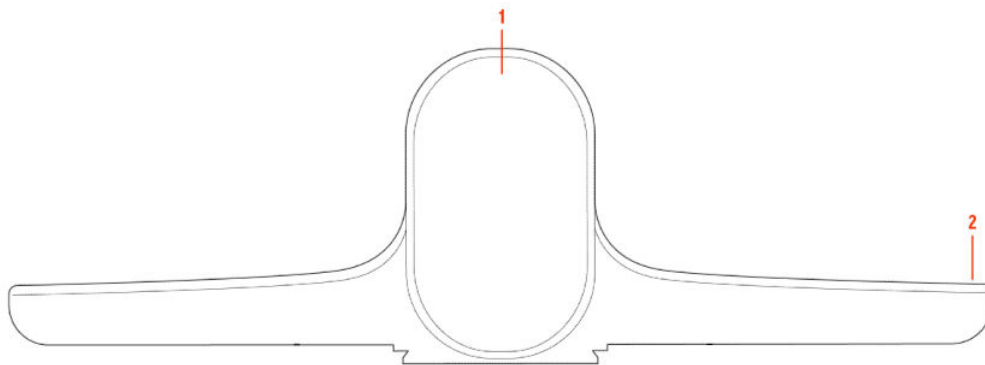



Table 2-13 Poly Studio E70 Feature Descriptions

| Reference Number | Feature | Description |
|------------------|----------------|--|
| 1 | Dual-cameras | Camera array with a privacy shutter that automatically opens or closes depending on the camera state |
| 2 | LED indicators | Front and right indicators that show the status of the camera |

Poly Studio E70 Ports

The following illustration and table explain the ports on your Poly Studio E70 camera.

 **IMPORTANT:** If you use an Ethernet port to power the Studio E70, the Ethernet port must be able to supply 30W PoE+ Type 2/Class 4 power.

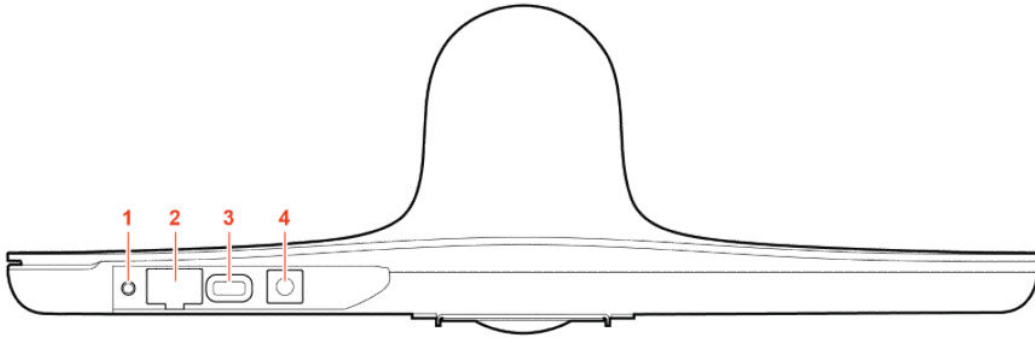

Table 2-14 Poly Studio E70 Port Descriptions

| Ref. Number | Port Description |
|-------------|--|
| 1 | Reset button |
| 2 | Ethernet port (Can be used to provide power to the camera) |
| 3 | USB-C port |
| 4 | Power cord port |

Poly Studio E70 Privacy Shutter Behavior

The privacy shutter automatically opens and closes depending on the state of the connected video system.

 **NOTE:** Shutter behavior may vary depending on the partner application.

| System Event | Shutter Behavior |
|---|--|
| The system powers on | Shutters open |
| The system powers off | Shutters close NOTE: If you remove power immediately, the shutters don't close. |
| The system enters sleep mode or digital signage starts and the Camera Sleep Setting is set to Save Energy | Shutters close |
| The system enters sleep mode or digital signage starts and Camera Sleep Setting is set to Fast Wake | Shutters remain open NOTE: When Fast Wake is set, the shutters never close. |
| You wake the system | Shutters open |
| You wake the system and the Studio E70 isn't the primary camera | Shutters remain closed |
| You select the Studio E70 as the primary camera | Shutters open |
| The Studio E70 isn't the primary camera and is idle for five minutes | Shutters close |

| System Event | Shutter Behavior |
|--|---|
| The system receives an incoming call | If the shutters are closed, they remain closed until the call is answered |
| The system is sending video | Shutters are open |
| The system is in an active call and the video is muted | Shutters are open |

LED Status Indicators

The following topics list the LED behavior for your system. The tables list each LED indicator and its associated status.

LED Status Indicators for the G7500 System

Use the LED on the front right corner of the codec to get information on the state of your system.

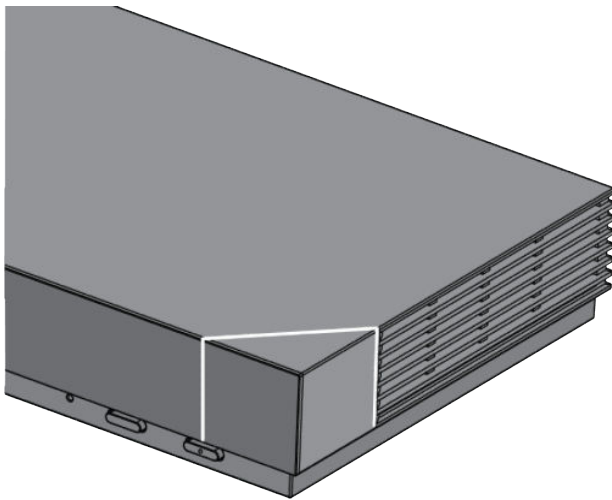

Table 2-15 G7500 System LED Status Indicators

| Indicator | Status |
|----------------|-----------------------------------|
| Blinking white | Powering on |
| Solid white | Working normally |
| Solid green | In a call |
| Blinking amber | Update in progress. |
| Solid amber | Sleeping |
| Blinking red | Error preventing normal operation |
| Solid red | Muted microphone |

LED Status Indicators for the Studio X70 System

Use the LED on the right side of the system to help you understand the system's behaviors.

Table 2-16 Basic Studio X70 LED Indicators and Status

| Indicator | Status |
|-------------------------|---|
| Solid white | Device is idle and standing by |
| Pulsing white | Boot initiation in progress |
| Pulsing amber | Firmware update or factor restore in progress |
| Blinking blue and white | Bluetooth pairing |
| Solid blue | Bluetooth paired |
| Solid green | Active call in progress |
| Solid red | Audio mute |

LED Status Indicators for Studio X50, and Studio X30 Systems

The system provides an LED light bar above the camera to help you understand the system's behaviors.

Table 2-17 Studio X50 and Studio X30 LED Indicators and Status

| Indicator | Position | Status |
|---------------------------|---|---|
| Solid white | All | Boot initialization in progress |
| Blinking blue | Twelve in the middle | Bluetooth in discover |
| Solid blue for 3 seconds | All | Bluetooth paired |
| Blinking green | All | Incoming call |
| Solid green | All | Outgoing call |
| Solid green | Four to eight (when in the middle), indicating the tracked speaker or the direction of the camera | Working The lights are green with supported applications in the following cases: <ul style="list-style-type: none"> Tracking people in group framing and speaker tracking mode Indicating the direction of the camera that you customize in pan-tilt-zoom (PTZ) mode |
| Solid amber | Twelve in the middle | Standing by System in sleep mode with no active video output |
| Pulsing red | Twelve in the middle | Call on hold |
| Pulsing green | Twelve in the middle | Call on hold (by far site) |
| Solid white for 3 seconds | Twelve in the middle | Saving a preset |
| Solid red | All | Muted microphone |
| Solid red | Four in the middle | Muted camera Muted microphone LEDs take precedence over camera mute LEDs |
| Pulsing amber | All | Firmware update in progress |

Table 2-17 Studio X50 and Studio X30 LED Indicators and Status (continued)

| Indicator | Position | Status |
|----------------|--------------------|---|
| Blinking red | All | Error preventing normal operation |
| Blinking amber | Twelve alternating | In a POST sequence, at least one test results in a warning error. The system continues to blink amber but initializes after the sequence is complete if no severe errors occur. |

LED Status Indicators for the Studio E70 Camera

The camera provides LED indicators on the front and right side of the camera to help you understand the camera's behaviors when connected to a G7500, Studio X series system, or a Windows PC.

Table 2-18 Studio E70 Camera System LED Status Indicators

| Color and Pattern | Status |
|-------------------------------|---|
| Pulsing white | Boot initialization is in progress |
| Solid white (50% brightness) | Powered on but disconnected from video system Sleep mode |
| Solid white (100% brightness) | Powered on and connected to the video system |
| Solid green | In a call or the camera is active |
| Pulsing amber | Firmware update or factory reset in progress |

Powering the System On and Off

The system powers on when you plug it in to a power source.

 **NOTE:**

- Don't restart or power off the system during maintenance activities (for example, while a software update is in progress).
- If a system restart is necessary, use the system web interface, RestAPI, Telnet, or SSH. If possible, avoid using the power cable to restart the system.

Wake the System

After a period of no activity, the system enters sleep mode (if configured by your administrator).

- Do one of the following:
 - If you're using a touch monitor, tap the primary screen.
 - If you're using the TC8, tap the screen.
 - If you're using a Poly Trio, tap the screen.

Accessibility Features

Poly products include a number of features to accommodate users with disabilities.

Users Who Are Deaf or Hard of Hearing

Your system includes accessibility features so that users who are deaf or hard of hearing can use the system.

The following table lists the accessibility features for users who are deaf or hard of hearing.

Table 2-19 Accessibility Features for Users Who Are Deaf or Hard of Hearing

| Accessibility Feature | Description |
|-------------------------|--|
| Visual notifications | Status and icon indicators let you know when you have incoming, outgoing, active, or held calls. Indicators also alert you of the device's status and when features are enabled. |
| Status indicator lights | The system uses LEDs to indicate some statuses, including if your microphones are muted. |
| Adjustable call volume | While in a call, you can raise or lower the volume of the device. |
| Auto-answering | You can enable the system to auto-answer calls. |

Users Who Are Blind, Have Low Vision, or Have Limited Vision

Your system includes accessibility features so that users who are blind, have low vision, or have limited vision can use the system.

The following table lists the accessibility features for users who are blind, have low vision, or have limited vision.

Table 2-20 Accessibility Features for Users Who Are Blind, Have Low Vision, or Have Limited Vision

| Accessibility Feature | Description |
|-------------------------------|--|
| Auto-answering | You can enable the system to auto-answer calls. |
| Adjustable backlight settings | You can change the brightness of the screen by adjusting backlight intensity settings. |
| Visual notifications | Status and icon indicators let you know when you have incoming, outgoing, active, or held calls. Indicators also alert you of the device's status and when features are enabled. |

Users with Limited Mobility

Your system includes accessibility features so that users with limited mobility can use various system features.

The following table lists the accessibility features for users with limited mobility.

Table 2-21 Accessibility Features for Users with Limited Mobility

| Accessibility Feature | Description |
|-------------------------------|---|
| Alternative control interface | This product provides an alternative control interface for the connected video conferencing system for people with disabilities that cause limited manipulation issues. |

Table 2-21 Accessibility Features for Users with Limited Mobility (continued)

| Accessibility Feature | Description |
|--|--|
| Auto-answering | You can enable the system to auto-answer calls. |
| Calling from a personal device | With administrator credentials, you can wirelessly access the system web interface from your own device to make calls and manage contacts and favorites. |
| Flexible mounting/display configurations | Product isn't stationary and can be mounted or displayed in various configurations. Touch controls require minimal strength to operate. |

3 Sharing Content

To enhance the collaboration experience, you can share documents, graphics, and videos with other participants using a computer.

Share Content Using an HDMI Connection

Share content from your device through an HDMI connection. This method doesn't require you to connect using a wireless service.

- Connect your device to the video system's HDMI input port.

4 Using Device Mode

Poly Device Mode enables you to use the system's camera, speaker, microphone, and connected monitors from your computer.

Once you connect the system to your computer with a USB cable, you can control the video system's camera and audio features using your computer's third-party conferencing application.

For example, instead of using your computer's camera for Zoom Rooms calls, connect the Studio X30 and use its 4K camera to automatically follow the conversation in the room. You also gain a Poly echo-cancelling microphone and speaker technology during calls.



NOTE: The system doesn't support hot plugging cameras. To connect a camera to the system, power the system off, connect the camera, and restart the system.

Computer and Cable Requirements for Device Mode

Your computer and cables must meet the following requirements to use Device Mode.

Operating system requirements:

- Windows 10 1803 or later
- macOS 10.12 or later

USB cable requirements:

- A cable with at least one USB-C connection for the video system
- USB 2.0 or USB 3.0 cable (preferred to ensure connection reliability and video and audio quality)
- Self-powered USB booster extension cable for connections longer than 2 m (6.6 ft)



NOTE: Don't use a cable used for charging devices. A charging cable may not be capable of sending data.

HDMI cable requirements:

- An HDMI adapter is required if your computer doesn't have an HDMI port

Access Device Mode

Use the system touchscreen or a TC10 or TC8 touch controller to start Device Mode.

 **NOTE:** Your administrator may configure your system to remain in Device Mode. If your system is already in Device Mode, the system monitor and TC10 or TC8 touch controller prompt you to connect a USB and HDMI cable to your computer.

Use Your System as a Computer Accessory

To use the video system as an external camera and audio accessory, set your system to Device Mode and connect your Windows or macOS computer with a USB cable.

If your system isn't already in Device Mode, access **Device Mode**. If your conferencing application uses echo cancellation, disable that feature.

You must use a cable with at least one USB-C connection for your video system. If you use a cable with only one USB-C connection, the USB-C end must connect to your video system for Device Mode to work properly.

 **NOTE:** Device Mode isn't available if your system administrator disables the system USB ports. If you need help with Device Mode or connecting a computer to your system, contact your administrator.

1. Connect a USB-C end of the USB cable to the video system's USB-C port, and connect the other end of the USB cable to your computer.

The system monitor and the TC10 or TC8 touch controller display a confirmation message.

2. To display your computer on the video system monitor, connect your computer using the system's HDMI input port.

Adjust the System Audio and Camera Settings in Device Mode

In Device Mode, you can mute the system, adjust the volume, and adjust camera settings.

Access **Device Mode** and connect your computer to the system.

 **NOTE:** The controls on a connected Poly Trio phone don't work if the system is in Device Mode.

1. To mute the microphones, do one of the following:
 - In a conference application on your computer, select mute.
 - On the controller or any connected microphone, select **Mute** .
2. To adjust the volume, do one of the following:
 - On the touchscreen or TC10 or TC8, select **Volume** and adjust the volume slider.
 - Adjust the volume from your computer using the computer or conference application settings.

 **NOTE:** Ensure that you select the correct device when adjusting the volume. Changing the volume alone may not work. You must have selected the Poly video system as the audio device.

3. To configure camera settings:

- a. From the right border of the TC10 or TC8 or the touchscreen, swipe left and select **Camera Settings**.
- b. Select **Camera Control**.
 - Turn **Camera Tracking** on or off.
 - Select or set a **Preset**.
 - Press **+** to zoom in or **-** to zoom out.
 - Press the arrows to tilt up and down or to pan left to right.

Managing Incoming Calls When in Device Mode

Exit Device Mode and Disconnect Your Computer

Any camera options you change on the video system with your USB-connected computer revert to their previous settings when you exit Device Mode.



NOTE: If the system is using Device Mode as the provider, **Exit** (⊗) isn't available.

- Do one of the following:
 - On the video system local interface or TC10 or TC8 touch controller, select **Exit** (⊗).
 - Unplug the cables connecting your computer and video system. After , you see the home screen (even if you haven't selected **Exit**).

5 Settings

Before or during calls, you can adjust the system volume. During calls, you can adjust your camera's position.

Cameras

Depending on the camera type, you can control the following options:

- Adjust near-site (local) camera positions.
- Turn tracking on or off.

Adjust an In-Room Camera

To enhance the view of meeting participants, make adjustments to the in-room camera.

If camera tracking is on, camera control is unavailable. Turn tracking off to access camera controls.



You can only make camera adjustments during a call.

With the Studio X50 and Studio X30 systems, you can't pan or tilt the camera if it's zoomed all the way out.

1. From the right border of your screen, swipe left.
2. Go to **Camera Settings** > **Camera Controls**.
3. Press **+** to zoom in or **-** to zoom out. Press the arrows to tilt up and down or to pan left to right.
4. To exit the control screen, select **Back** ← .

Turn Camera Tracking On or Off

When camera tracking is on, the camera automatically frames the group of people in the room or the current speaker (depending on your camera and how your system is configured).

1. From the right border of your screen, swipe left.
2. Select **Camera Settings**.
3. Select **Tracking On**  or **Tracking Off** .

Audio Adjustments

You can control several audio settings on the system.

Adjust the Volume

You can adjust the volume before or during a call.

- Use the volume slider on the device controlling your video system.

6 Troubleshooting

This section includes information related to troubleshooting issues with your system. You can also find information on pairing your remote, configuring your monitors, and where to find help tips.

Poly Device Mode

Use these topics to troubleshoot problems you may encounter using Device Mode.

Audio Levels are Too High or Low

In Device Mode, audio from the video system speakers is too loud or it's difficult to hear call participants.

In Device Mode, your conferencing application and laptop control the video system's audio. You may need to adjust those volume controls.

Follow these steps until you get the audio levels you want:

1. Adjust your conferencing application's volume.
2. Adjust your laptop's volume.

Conferencing Application Doesn't Use System Camera or Audio

Your conferencing application isn't using the video system's camera or audio in Device Mode.

Your conferencing application by default may choose the connected monitor speakers instead of, for example, the Studio X50 speakers.

- In your conferencing application, select the video system as your speaker, microphone, and camera device.

Can't Use System's Camera or Audio

Your conferencing application isn't using the video system's camera or audio in Device Mode. There could be a few reasons for these types of problems. For instance, your conferencing application by default may choose the connected monitor speakers instead of, for example, the Studio X50 speakers.

You may notice the following while using Device Mode:

- In your laptop's conferencing application, you can't select the video system as a camera or audio source.
- The video system's camera and audio seem unavailable.

- The video system's camera doesn't display live video.

Follow these steps until you fix your problem:

1. In your conferencing application, select the video system as your speaker, microphone, and camera device.
2. In your laptop settings, select the video system as your speaker, microphone, and camera device.
3. Exit and restart Device Mode.
4. Replug the USB cable.
5. Connect the cable to a different USB port on your laptop.
6. Try using a different USB cable.
7. Restart your laptop.

Improve Audio Quality

Audio quality during calls in Device Mode could be better. For example, people on the call notice interference or dropped words when you're speaking.

You may encounter these problems for the following reasons: additional USB connections, a bad cable, or audio processing settings.

Follow these steps until your audio quality improves:

1. Remove USB audio devices (such as a headset) connected to your laptop.
2. Connect your laptop and video system with a different USB cable.
3. If your conferencing application uses echo cancellation, disable that feature.
4. If you're playing a musical instrument, enable M-Mode in the system web interface.

Improve Laptop Screen Mirroring

When mirroring your laptop screen with an HDMI connection, the picture on the connected monitor isn't ideal.

The resolution on your laptop may need to be adjusted for the monitor connected to the Poly video system.

Follow these steps until screen mirroring quality improves:

1. Adjust your laptop's resolution settings.
2. Adjust your laptop's display settings so the screen duplicates on the monitor.

7 Getting help

Poly is now a part of HP. The joining of Poly and HP will pave the way for us to create the hybrid work experiences of the future.

During the merge of our two organizations, information about Poly products will transition from the [Poly Support](#) site to the [HP® Support](#) site.

The [Poly Documentation Library](#) will continue to host the installation, configuration, and administration guides for Poly products in HTML and PDF format. In addition, the Poly Documentation Library will provide Poly customers with up-to-date status information about the transition of Poly content from the [Poly Support](#) site to the [HP® Support](#) site.

■ HP Inc. addresses

HP US
HP Inc.
1501 Page Mill Road
Palo Alto 94304, U.S.A.
650-857-1501

HP Germany
HP Deutschland GmbH
HP HQ-TRE
71025 Boeblingen, Germany

HP UK
HP Inc UK Ltd
Regulatory Enquiries, Earley West
300 Thames Valley Park Drive
Reading, RG6 1PT
United Kingdom

■ Document information

Model ID: Poly Bluetooth® Remote Control (model: P010), Poly IR Receiver (model: BW7650), Poly IR Remote (model: BW7600), Poly Microphone IP Adapter (model: P012), Poly IP Table Microphone (model: P013), Poly IP Ceiling Microphone (model: P014), Poly Studio X70 (model: P026), Poly Studio X50 (model: P017), Poly Studio X30 (model: P018), Poly Studio E70 (model: P025), Poly TC10 (model: P030), Poly TC8 (model: P020)

Document part number: 3725-00000-001A

Last update: June 2023

Email us at documentation.feedback@hp.com with queries or suggestions related to this document.