

Poly CCX 400 Business Media Phone

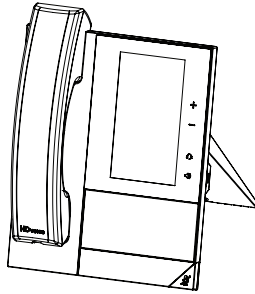

Package Contents

CCX 400

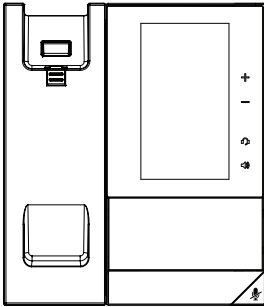

Handset

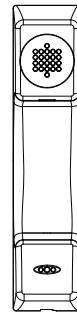

Stand

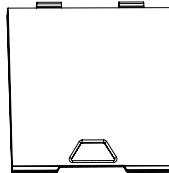

Setup Sheet



Handset Cord

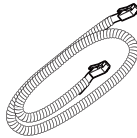

Network Cable

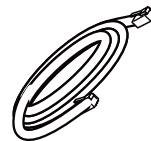

Optional Accessories

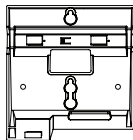
AC Power Adapter
(varies by region)

Wallmount

Features

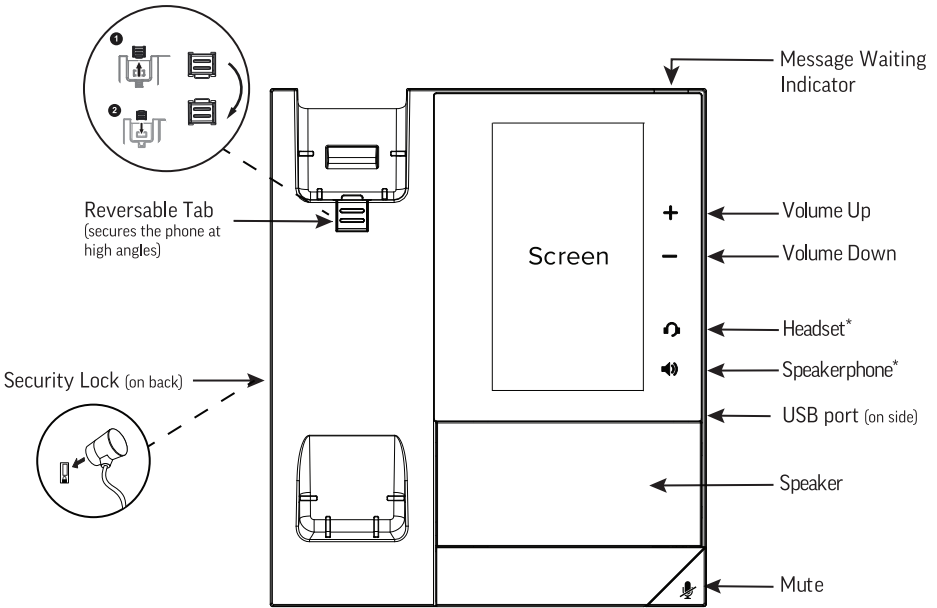

* Icon displays when the phone is powered on.

Connect Desktop Stand

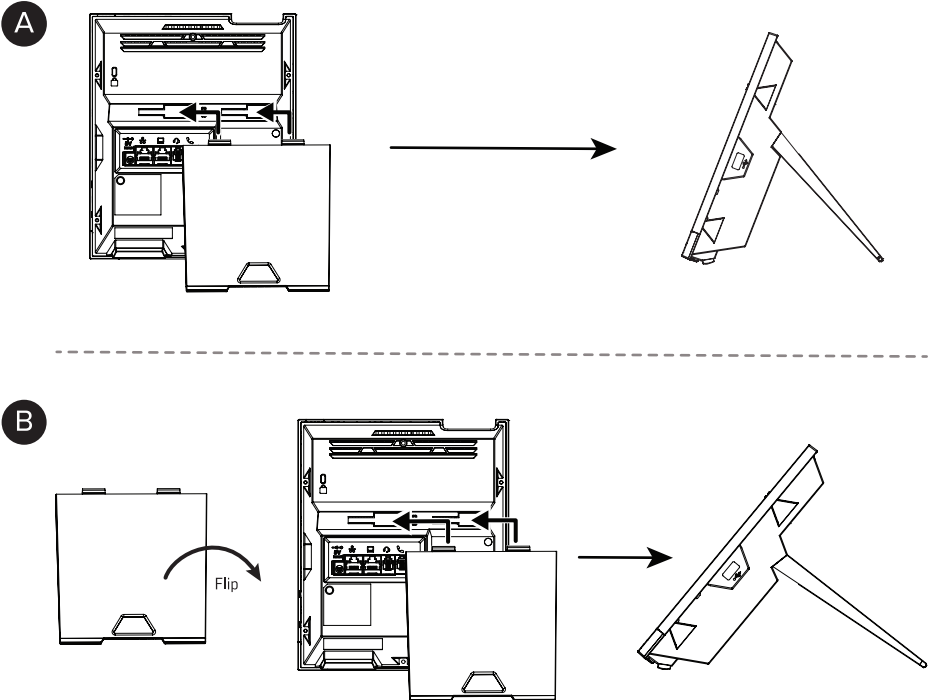

Connect Cables

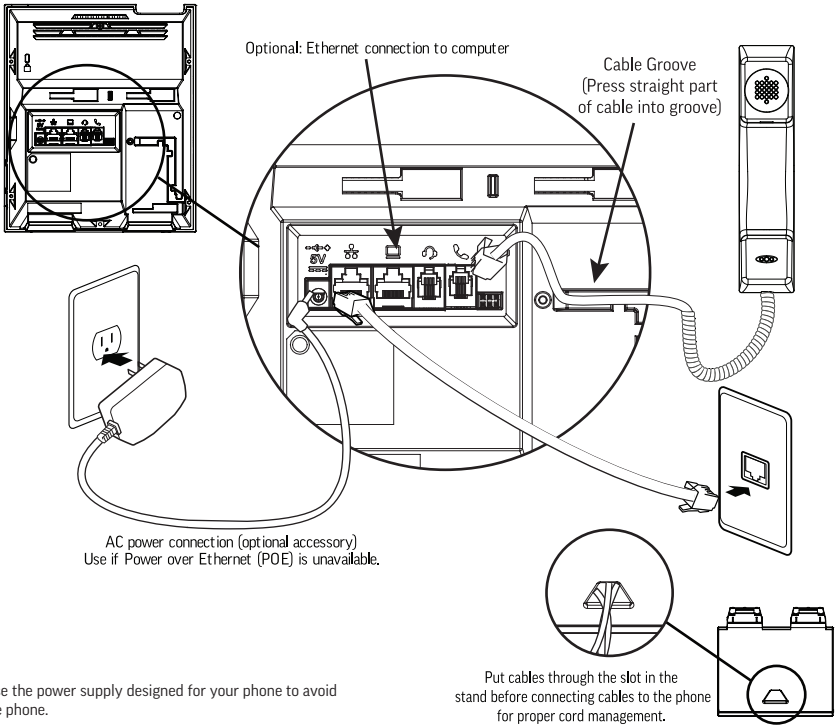

Connect Optional Headset

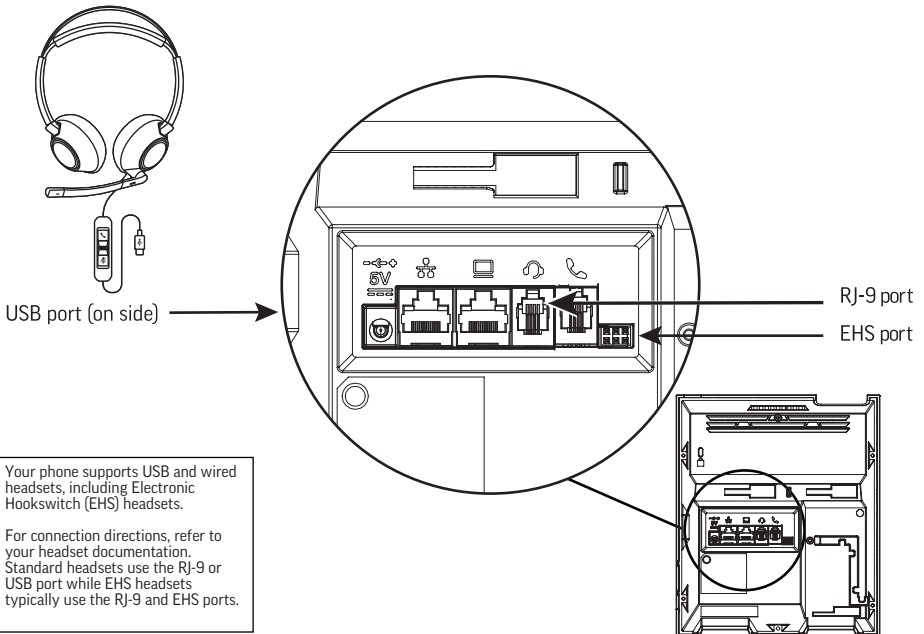



BY USING THIS PRODUCT, YOU ARE AGREEING TO THE TERMS OF THE END USER LICENSE AGREEMENT (EULA) AT:
<http://documents.polycom.com/indexes/licenses>. IF YOU DO NOT AGREE TO THE TERMS OF THE EULA, DO NOT USE THE PRODUCT, AND YOU MAY RETURN IT IN THE ORIGINAL PACKAGING TO THE SELLER FROM WHOM YOU PURCHASED THE PRODUCT.

Refer to the Limited Warranty section of the Product Warranty Guide found under Service Policies at
<http://support.polycom.com/>

ENERGY STAR®:



Backlight intensity and timeout can be adjusted in basic user settings menu. By default, after the phone is idle for 40 seconds, the backlight dims. The backlight automatically turns on with any phone activity.

Polycom Documentation
www.polycom.com/support



Contact Information:

Contact your Authorized Reseller for Assistance.
www.poly.com

Plantronics, Inc. 345 Encinal Street Santa Cruz, California 95060

1725-49705-001A

