

AXIS T6112 MK II Audio and I/O Interface

Repainting instructions

AXIS T6112 MK II Audio and I/O Interface

Impact on warranty

Impact on warranty

This product is approved for repaint by Axis, provided that you follow the instructions in this document and at axis.com/warranty-implication-when-repainting.

Risks with repainting

There are several risks when disassembling or assembling an Axis product. There is always a certain yield loss during assembly. Training of operators and the use of correct tools mediates some of the problems but they can never be fully avoided. Some of the risks include:

ESD Damage – Always handle the product in an ESD safe environment. Even if precautions are taken there is always a risk of ESD damage. The damage can remain undetected and cause problems during the lifetime of the equipment.

Paint overspray – Masking the different components of the equipment is critical. Failure to mask sensitive areas can cause problems with assembling the equipment. Any areas that are not painted at factory or have a different surface treatment than the rest of the parts (threads, ground and electrical contact surfaces) must also be masked to ensure function.

AXIS T6112 MK II Audio and I/O Interface

Repaint the product

Repaint the product

Preparations

- If applicable, disassemble the device according to the instructions in this document.
- Clean all parts that will be repainted thoroughly to remove grease, dust, or oil.
- To ensure reassembly and functionality of the product, mask any openings (for example for screws, LED indicators, or microphones) before you paint.

Pretreatment of parts

Depending on the part material and type of paint applied at factory, different pretreatment should be done for the new paint to adhere as well as possible. Clean the parts properly to remove oil, grease and dust.

Powder coated parts – Use a primer. Alternatively, remove the original powder coating down to the base material, using fine sandpaper, and clean the parts before painting.

Anodised and chromated parts – Use a primer.

Uncoated stainless steel – No special pretreatment is needed, but make sure that the surface is clean before painting.

Plastic – Use a primer.

The material used in the product is PC+ABS Infino GW-1041.

Disassembly

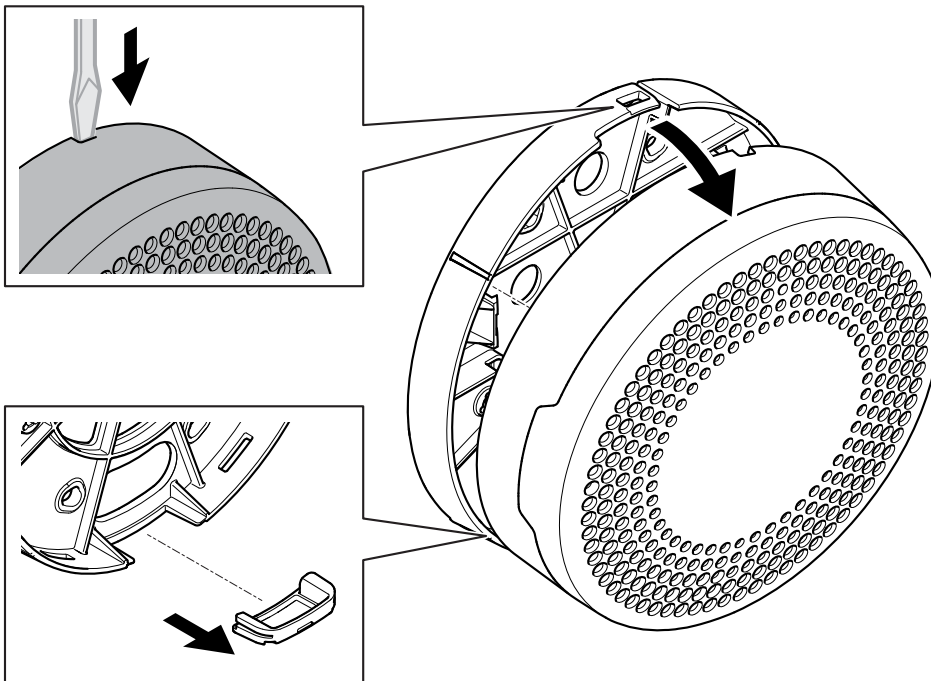

1. Use a flat-headed screwdriver to remove the cover.

AXIS T6112 MK II Audio and I/O Interface

Repaint the product

2. Remove the side lid (if used).
3. Disconnect the Audio connector.

Repainting

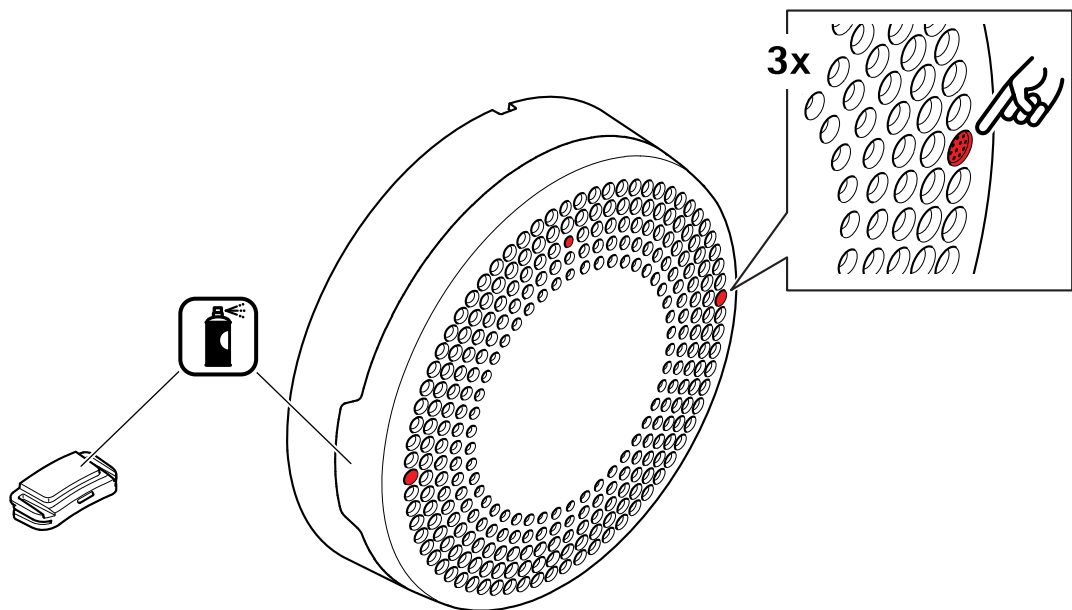

1. Make sure you have made all necessary preparations of the parts to be repainted.
2. Apply a thin and even layer of spray paint according to the instructions of the paint manufacturer.

AXIS T6112 MK II Audio and I/O Interface

Repaint the product

⚠CAUTION

Make sure the paint doesn't clog the holes on the cover. If paint clogs the three mic and light guide holes the microphone will not register any sound.

3. Let the paint dry according to the paint manufacturer's recommendations.
4. To get a better coverage and clearer color, apply a second layer of spray paint.
5. When the paint is dry, reassemble the product.

Reassembly

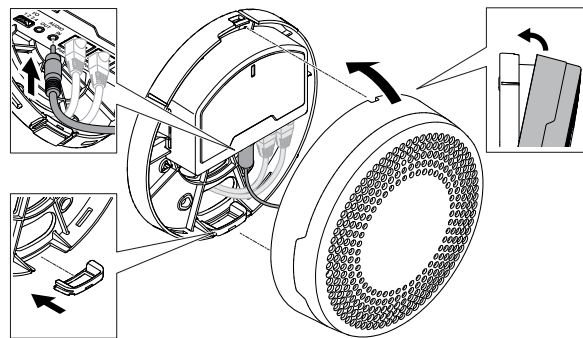

1. Connect the microphone to the Audio in connector.
2. Attach the side lid (if used) to the bracket mount.
3. Attach the cover to the bracket mount.

