



HPE ProLiant Compute ML350 Gen12 Maintenance and Service Guide

Part Number: 30-50DF3739-003

Published: April 2026

Edition: 3

HPE ProLiant Compute ML350 Gen12 Maintenance and Service Guide

Abstract

This document is for the person who installs, administers, and troubleshoots servers and storage systems. Hewlett Packard Enterprise assumes you are qualified in the servicing of computer equipment and trained in recognizing hazards in products with hazardous energy levels.

Part Number: 30-50DF3739-003

Published: April 2026

Edition: 3

© Copyright 2025–2026 Hewlett Packard Enterprise Development LP

Notices

The information provided here is subject to change without notice. Hewlett Packard Enterprise's products and services are covered only by the express warranty statements that come with them. This document does not constitute an additional warranty. Hewlett Packard Enterprise is not responsible for any technical or editorial errors or omissions in this document.

Confidential computer software. You must have a valid license from Hewlett Packard Enterprise to possess, use, or copy the software. In accordance with FAR 12.211 and 12.212, Commercial Computer Software, Computer Software Documentation, and Technical Data for Commercial Items are licensed to the U.S. Government under the vendor's standard commercial license.

Links to third-party websites will take you outside of the Hewlett Packard Enterprise website. Hewlett Packard Enterprise has no control over and is not responsible for the information outside the Hewlett Packard Enterprise website.

Acknowledgments

Intel®, Intel® Virtual RAID on CPU (Intel® VROC), and Xeon® are trademarks of Intel Corporation in the United States and other countries.

Linux® is the registered trademark of Linus Torvalds in the U.S. and other countries.

Microsoft®, Windows®, and Windows Server® are either registered trademarks or trademarks of Microsoft Corporation in the United States and/or other countries.

VMware® is a registered trademark or trademark of VMware Inc. and its subsidiaries in the United States and other jurisdictions.

All third-party marks are property of their respective owners.

Table of contents

Customer self repair.....	9
Illustrated parts catalog.....	19
Mechanical components.....	20
Front bezel spare part.....	21
Boot device cage assembly spare part.....	21
Front I/O module spare part.....	22
Fan cage spare part.....	22
DIMM guard spare parts.....	22
Miscellaneous blank spare parts.....	23
Miscellaneous mechanical spare parts.....	24
Drive blank spare parts.....	25
Cable management arm spare part.....	25
Rack rails spare part.....	25
System components.....	26
Internal fan spare part.....	26
Heatsink spare parts.....	27
Processor spare parts.....	27
DIMM spare parts.....	28
Power supply spare parts.....	28
System battery spare part.....	29
System board spare part.....	29
Drive cable spare parts.....	30
Server options.....	31
Drive backplane spare parts.....	33
Chassis intrusion detection switch spare part.....	33
HPE NS204i-u Boot Device V2 spare parts.....	33
Serial port cable spare part.....	34
Riser board spare parts.....	35
External fan spare parts.....	35
Energy pack spare parts.....	36
Storage controller spare parts.....	36
Media device cable spare part.....	37
OCP bandwidth upgrade cable spare parts.....	37
Tertiary riser signal cable spare part.....	37

GPU auxiliary power cable spare part.....	38
Removal and replacement procedures.....	38
Safety considerations.....	39
Electrostatic discharge.....	39
Symbols on equipment.....	40
Rack warnings and cautions.....	46
Server warnings and cautions.....	48
Preparation procedures.....	49
Server data backup.....	49
Power down the server.....	50
Position the tower server for hardware configuration.....	51
Extend the server from the rack.....	52
Remove the server from the rack.....	53
Remove the access panel.....	56
Remove the drive cage	58
Remove the primary riser cage.....	61
Remove the secondary riser cage blank.....	63
Remove the secondary riser cage.....	64
Remove the energy pack and the energy pack holder.....	67
Remove the fan cage bracket.....	69
Remove the HPE NS204i-u Boot Device V2 on the power supply cage.....	70
Power up the server.....	72
Removing and replacing the front bezel.....	72
Removing and replacing a hot-plug LFF / SFF / E3.S drive.....	73
Removing and replacing the drive box blank.....	76
Removing and replacing a drive blank.....	78
Removing and replacing the media bay filler panel.....	80
Flexible Slot power supply replacement.....	82
Power supply warnings and cautions.....	83
DC power supply warnings and cautions.....	84
Removing and replacing a Flexible Slot power supply.....	84
Removing and replacing a power supply blank.....	91
Removing and replacing the cable management arm.....	92
Removing and replacing the rack rails.....	93
Media device replacement.....	98
Removing and replacing a SAS LTO tape drive.....	98
Removing and replacing the optical drive.....	100
Removing and replacing the front I/O module.....	104

Drive backplane replacement.....	106
Removing and replacing the 4 LFF drive backplane.....	107
Removing and replacing the 8 SFF drive backplane.....	109
Removing and replacing the 4 E3.S drive backplane.....	111
Fan replacement.....	113
Fan population.....	114
Removing and replacing the internal fan in hot-plug mode.....	115
Removing and replacing the internal fan in non-hot-plug mode.....	116
Removing and replacing the external fan.....	118
Removing and replacing the fan blank.....	119
Removing and replacing the fan cage.....	121
Removing and replacing the system board handle.....	123
Removing and replacing a DIMM.....	125
Removing and replacing a DIMM guard.....	129
Removing and replacing the chassis intrusion detection switch.....	131
Removing and replacing a cable clamp.....	133
HPE NS204i-u Boot Device V2 replacement.....	134
Removing and replacing a boot device drive	134
Removing and replacing the boot device V2 cage on the front panel.....	140
Removing and replacing the boot device V2 cage on the rear panel.....	143
Removing and replacing the front boot device cage assembly.....	148
Removing and replacing the boot device baffle.....	152
Removing and replacing the boot device latch.....	154
Removing and replacing the boot device blank.....	158
Removing and replacing the energy pack.....	159
Removing and replacing the energy pack holder.....	161
Expansion card replacement.....	163
Removing and replacing an expansion card from the primary or secondary riser cage....	163
Removing and replacing an expansion card from the tertiary riser.....	165
Riser board replacement.....	168
Removing and replacing the primary/secondary riser board.....	168
Removing and replacing the tertiary riser board.....	171
Removing and replacing a type-o storage controller.....	174
Removing and replacing the OCP NIC adapter.....	176
Removing and replacing an OCP slot blank.....	178
Removing and replacing the left OCP A Slot 14 rail.....	180
Removing and replacing the secondary riser cage blank.....	182
Removing and replacing the external fan connector blank.....	184

Removing and replacing the external fan cable.....	185
Removing and replacing the serial port cable.....	187
Removing and replacing the serial port blank.....	188
Removing and replacing the tertiary riser slot cover.....	189
Heatsink replacement.....	191
Removing the heatsink.....	191
Installing the heatsink.....	203
Processor replacement.....	221
Processor cautions.....	221
Removing the processor.....	222
Installing the processor.....	233
System board replacement.....	250
Removing the system board.....	250
Installing the system board.....	261
Re-entering the server serial number and product ID.....	272
System battery replacement.....	273
System battery information.....	274
Removing and replacing the system battery.....	274
Component identification.....	277
Front panel components.....	278
Front panel LEDs and button.....	282
Server UID LED.....	283
Viewing the Server Health Summary.....	283
Rear panel components.....	285
Rear panel LEDs.....	287
Component touchpoints.....	288
System board components.....	290
System maintenance switch.....	292
DIMM label identification.....	293
DIMM slot numbering.....	294
Heatsink and processor socket components.....	295
Fan bay numbering.....	295
Drive bay numbering.....	296
LFF drive bay numbering.....	297
SFF drive bay numbering.....	298
Mixed drive bay numbering.....	300
E3.S drive bay numbering.....	316
Drive backplane naming.....	317

HPE Basic Drive LED definitions.....	318
EDSFF SSD LED definitions.....	320
HPE NS204i-u Boot Device V2 components.....	322
HPE NS204i-u Boot Device V2 LED definitions	323
Riser board components.....	324
Riser slot numbering.....	325
Media device screws.....	327
Troubleshooting.....	328
NMI functionality.....	328
Front panel LED power fault codes.....	328
Troubleshooting resources.....	329
Cabling.....	329
Cabling guidelines.....	330
Cabling diagrams.....	332
Internal cabling management.....	335
Storage cabling.....	336
Drive power cabling.....	336
Storage controller cabling.....	338
SFF drive controller cabling.....	338
LFF drive controller cabling.....	345
E3.S drive controller cabling.....	349
Mixed drive controller cabling.....	351
Storage controller backup power cabling.....	351
Energy pack cabling.....	353
Media device cabling.....	353
LTO tape drive cabling.....	354
Optical drive cabling.....	356
HPE NS204i-u Boot Device V2 cabling.....	357
GPU auxiliary power cabling.....	358
Fan cabling.....	360
OCP bandwidth enablement cabling.....	362
Tertiary riser signal cabling.....	365
Serial port cabling.....	366
Chassis intrusion detection switch cabling.....	367
Front I/O cabling.....	367
Configuration resources.....	368
Updating firmware or system ROM.....	369
Configuring the server.....	370

Configuring storage controllers.....	372
Deploying an OS.....	373
Configuring security.....	374
Server management.....	374
Managing Linux-based high performance compute clusters.....	375
Safety, warranty, and regulatory information.....	375
Regulatory information.....	376
Notices for Eurasian Economic Union.....	376
Turkey RoHS material content declaration.....	377
Ukraine RoHS material content declaration.....	378
Warranty information.....	378
Specifications.....	378
Environmental specifications.....	378
Mechanical specifications.....	379
Power supply specifications.....	380
HPE 800 W Flex Slot Platinum Hot-plug Low Halogen Power Supply.....	381
HPE 1000 W Flex Slot Titanium Hot-plug Power Supply.....	382
HPE 1600 W Flex Slot Platinum Hot-plug Low Halogen Power Supply.....	383
HPE 1600 W Flex Slot -48 VDC Hot-plug Power Supply.....	383
HPE 1800-2200 W Flex Slot Titanium Power Supply.....	384
Websites.....	385
Support and other resources.....	385
Accessing Hewlett Packard Enterprise Support.....	386
HPE product registration.....	386
Accessing updates.....	387
Remote support.....	387
Documentation feedback.....	388

Customer self repair

Hewlett Packard Enterprise products are designed with many Customer Self Repair (CSR) parts to minimize repair time and allow for greater flexibility in performing defective parts replacement. If during the diagnosis period Hewlett Packard Enterprise (or Hewlett Packard Enterprise service providers or service partners) identifies that the repair can be accomplished by the use of a CSR part, Hewlett Packard Enterprise will ship that part directly to you for replacement. There are two categories of CSR parts:

- **Mandatory**—Parts for which customer self repair is mandatory. If you request Hewlett Packard Enterprise to replace these parts, you will be charged for the travel and labor costs of this service.
- **Optional**—Parts for which customer self repair is optional. These parts are also designed for customer self repair. If, however, you require that Hewlett Packard Enterprise replace them for you, there may or may not be additional charges, depending on the type of warranty service designated for your product.



NOTE

Some Hewlett Packard Enterprise parts are not designed for customer self repair. In order to satisfy the customer warranty, Hewlett Packard Enterprise requires that an authorized service provider replace the part. These parts are identified as "No" in the Illustrated Parts Catalog.

Based on availability and where geography permits, CSR parts will be shipped for next business day delivery. Same day or four-hour delivery may be offered at an additional charge where geography permits. If assistance is required, you can contact the Hewlett Packard Enterprise Support Center and a technician will help you over the telephone or by electronic means. Hewlett Packard Enterprise specifies in the materials shipped with a replacement CSR part whether a defective part must be returned to Hewlett Packard Enterprise. In cases where it is required to return the defective part to Hewlett Packard Enterprise, you must ship the defective part back to Hewlett Packard Enterprise within a defined period of time, normally five (5) business days. The defective part must be returned with the associated documentation in the provided shipping material. Failure to return the defective part may result in Hewlett Packard Enterprise billing you for the replacement. With a customer self repair, Hewlett Packard Enterprise will pay all shipping and part return costs and determine the courier/carrier to be used.

For more information about the Hewlett Packard Enterprise CSR program, contact your local service provider.

Parts only warranty service

Your Hewlett Packard Enterprise Limited Warranty may include a parts only warranty service. Under the terms of parts only warranty service, Hewlett Packard Enterprise will provide replacement parts free of charge.

For parts only warranty service, CSR part replacement is mandatory. If you request Hewlett Packard Enterprise to replace these parts, you will be charged for the travel and labor costs of this service.

Réparation par le client (CSR)

Les produits Hewlett Packard Enterprise comportent de nombreuses pièces CSR (Customer Self Repair = réparation par le client) afin de minimiser les délais de réparation et faciliter le remplacement des pièces défectueuses. Si pendant la période de diagnostic, Hewlett Packard Enterprise (ou ses partenaires ou mainteneurs agréés) détermine que la réparation peut être effectuée à l'aide d'une pièce CSR, Hewlett Packard Enterprise vous l'envoie directement. Il existe deux catégories de pièces CSR :

- **Obligatoire**—Pièces pour lesquelles la réparation par le client est obligatoire. Si vous demandez à Hewlett Packard Enterprise de remplacer ces pièces, les coûts de déplacement et main d'œuvre du service vous seront facturés.
- **Facultatif**—Pièces pour lesquelles la réparation par le client est facultative. Ces pièces sont également conçues pour permettre au client d'effectuer lui-même la réparation. Toutefois, si vous demandez à Hewlett Packard Enterprise de remplacer ces pièces, l'intervention peut ou non vous être facturée, selon le type de garantie applicable à votre produit.

REMARQUE: Certaines pièces Hewlett Packard Enterprise ne sont pas conçues pour permettre au client d'effectuer lui-même la réparation. Pour que la garantie puisse s'appliquer, Hewlett Packard Enterprise exige que le remplacement de la pièce soit effectué par un Mainteneur Agréé. Ces pièces sont identifiées par la mention "Non" dans le Catalogue illustré.

Les pièces CSR sont livrées le jour ouvré suivant, dans la limite des stocks disponibles et selon votre situation géographique. Si votre situation géographique le permet et que vous demandez une livraison le jour même ou dans les 4 heures, celle-ci vous sera facturée. Pour toute assistance, appelez le Centre d'assistance Hewlett Packard Enterprise pour qu'un technicien vous aide au téléphone. Dans les documents envoyés avec la pièce de rechange CSR, Hewlett Packard Enterprise précise s'il est nécessaire de lui retourner la pièce défectueuse. Si c'est le cas, vous devez le faire dans le délai indiqué, généralement cinq (5) jours ouvrés. La pièce et sa documentation doivent être retournées dans l'emballage fourni. Si vous ne retournez pas la pièce défectueuse, Hewlett Packard Enterprise se réserve le droit de vous facturer les coûts de remplacement. Dans le cas d'une pièce CSR, Hewlett Packard Enterprise supporte l'ensemble des frais d'expédition et de retour, et détermine la société de courses ou le transporteur à utiliser.

Pour plus d'informations sur le programme CSR de Hewlett Packard Enterprise, contactez votre Mainteneur Agréé local.

Service de garantie "pièces seules"

Votre garantie limitée Hewlett Packard Enterprise peut inclure un service de garantie "pièces seules". Dans ce cas, les pièces de rechange fournies par Hewlett Packard Enterprise ne sont pas facturées.

Dans le cadre de ce service, la réparation des pièces CSR par le client est obligatoire. Si vous demandez à Hewlett Packard Enterprise de remplacer ces pièces, les coûts de déplacement et main d'œuvre du service vous seront facturés.

Riparazione da parte del cliente

Per abbreviare i tempi di riparazione e garantire una maggiore flessibilità nella sostituzione di parti difettose, i prodotti Hewlett Packard Enterprise sono realizzati con numerosi componenti che possono essere riparati direttamente dal cliente (CSR, Customer Self Repair). Se in fase di diagnostica Hewlett Packard Enterprise (o un centro di servizi o di assistenza Hewlett Packard Enterprise) identifica il guasto come riparabile mediante

un ricambio CSR, Hewlett Packard Enterprise lo spedisce direttamente al cliente per la sostituzione. Vi sono due categorie di parti CSR:

- **Obbligatorie**—Parti che devono essere necessariamente riparate dal cliente. Se il cliente ne affida la riparazione ad Hewlett Packard Enterprise, deve sostenere le spese di spedizione e di manodopera per il servizio.
- **Opzionali**—Parti la cui riparazione da parte del cliente è facoltativa. Si tratta comunque di componenti progettati per questo scopo. Se tuttavia il cliente ne richiede la sostituzione ad Hewlett Packard Enterprise, potrebbe dover sostenere spese addizionali a seconda del tipo di garanzia previsto per il prodotto.

NOTA: alcuni componenti Hewlett Packard Enterprise non sono progettati per la riparazione da parte del cliente. Per rispettare la garanzia, Hewlett Packard Enterprise richiede che queste parti siano sostituite da un centro di assistenza autorizzato. Tali parti sono identificate da un "No" nel Catalogo illustrato dei componenti.

In base alla disponibilità e alla località geografica, le parti CSR vengono spedite con consegna entro il giorno lavorativo seguente. La consegna nel giorno stesso o entro quattro ore è offerta con un supplemento di costo solo in alcune zone. In caso di necessità si può richiedere l'assistenza telefonica di un addetto del centro di supporto tecnico Hewlett Packard Enterprise. Nel materiale fornito con una parte di ricambio CSR, Hewlett Packard Enterprise specifica se il cliente deve restituire dei componenti. Qualora sia richiesta la resa ad Hewlett Packard Enterprise del componente difettoso, lo si deve spedire ad Hewlett Packard Enterprise entro un determinato periodo di tempo, generalmente cinque (5) giorni lavorativi. Il componente difettoso deve essere restituito con la documentazione associata nell'imballo di spedizione fornito. La mancata restituzione del componente può comportare la fatturazione del ricambio da parte di Hewlett Packard Enterprise. Nel caso di riparazione da parte del cliente, Hewlett Packard Enterprise sostiene tutte le spese di spedizione e resa e sceglie il corriere/vettore da utilizzare.

Per ulteriori informazioni sul programma CSR di Hewlett Packard Enterprise, contattare il centro di assistenza di zona.

Servizio di garanzia per i soli componenti

La garanzia limitata Hewlett Packard Enterprise può includere un servizio di garanzia per i soli componenti. Nei termini di garanzia del servizio per i soli componenti, Hewlett Packard Enterprise fornirà gratuitamente le parti di ricambio.

Per il servizio di garanzia per i soli componenti è obbligatoria la formula CSR che prevede la riparazione da parte del cliente. Se il cliente invece richiede la sostituzione ad Hewlett Packard Enterprise dovrà sostenere le spese di spedizione e di manodopera per il servizio.

Customer Self Repair

Hewlett Packard Enterprise Produkte enthalten viele CSR-Teile (Customer Self Repair), um Reparaturzeiten zu minimieren und höhere Flexibilität beim Austausch defekter Bauteile zu ermöglichen. Wenn Hewlett Packard Enterprise (oder ein Hewlett Packard Enterprise Servicepartner) bei der Diagnose feststellt, dass das Produkt mithilfe eines CSR-Teils repariert werden kann, sendet Ihnen Hewlett Packard Enterprise dieses Bauteil zum Austausch direkt zu. CSR-Teile werden in zwei Kategorien unterteilt:

- **Zwingend**—Teile, für die das Customer Self Repair-Verfahren zwingend vorgegeben ist. Wenn Sie den Austausch dieser Teile von Hewlett Packard Enterprise vornehmen lassen, werden Ihnen die Anfahrt- und Arbeitskosten für diesen Service berechnet.
- **Optional**—Teile, für die das Customer Self Repair-Verfahren optional ist. Diese Teile sind auch für Customer Self Repair ausgelegt. Wenn Sie jedoch den Austausch dieser Teile von Hewlett Packard Enterprise vornehmen lassen möchten, können bei diesem Service je nach den für Ihr Produkt vorgesehenen Garantiebedingungen zusätzliche Kosten anfallen.

HINWEIS: Einige Hewlett Packard Enterprise Teile sind nicht für Customer Self Repair ausgelegt. Um den Garantieanspruch des Kunden zu erfüllen, muss das Teil von einem Hewlett Packard Enterprise Servicepartner ersetzt werden. Im illustrierten Teilekatalog sind diese Teile mit „No“ bzw. „Nein“ gekennzeichnet.

CSR-Teile werden abhängig von der Verfügbarkeit und vom Lieferziel am folgenden Geschäftstag geliefert. Für bestimmte Standorte ist eine Lieferung am selben Tag oder innerhalb von vier Stunden gegen einen Aufpreis verfügbar. Wenn Sie Hilfe benötigen, können Sie das Hewlett Packard Enterprise Support Center anrufen und sich von einem Mitarbeiter per Telefon helfen lassen. Den Materialien von Hewlett Packard Enterprise, die mit einem CSR-Ersatzteil geliefert werden, können Sie entnehmen, ob das defekte Teil an Hewlett Packard Enterprise zurückgeschickt werden muss. Wenn es erforderlich ist, das defekte Teil an Hewlett Packard Enterprise zurückzuschicken, müssen Sie dies innerhalb eines vorgegebenen Zeitraums tun, in der Regel innerhalb von fünf (5) Geschäftstagen. Das defekte Teil muss mit der zugehörigen Dokumentation in der Verpackung zurückgeschickt werden, die im Lieferumfang enthalten ist. Wenn Sie das defekte Teil nicht zurückschicken, kann Hewlett Packard Enterprise Ihnen das Ersatzteil in Rechnung stellen. Im Falle von Customer Self Repair kommt Hewlett Packard Enterprise für alle Kosten für die Lieferung und Rücksendung auf und bestimmt den Kurier-/Frachtdienst.

Weitere Informationen über das Hewlett Packard Enterprise Customer Self Repair Programm erhalten Sie von Ihrem Servicepartner vor Ort.

Parts-only Warranty Service (Garantieservice ausschließlich für Teile)

Ihre Hewlett Packard Enterprise Garantie umfasst möglicherweise einen Parts-only Warranty Service (Garantieservice ausschließlich für Teile). Gemäß den Bestimmungen des Parts-only Warranty Service stellt Hewlett Packard Enterprise Ersatzteile kostenlos zur Verfügung.

Für den Parts-only Warranty Service ist das CSR-Verfahren zwingend vorgegeben. Wenn Sie den Austausch dieser Teile von Hewlett Packard Enterprise vornehmen lassen, werden Ihnen die Anfahrt- und Arbeitskosten für diesen Service berechnet.

Reparaciones del propio cliente

Los productos de Hewlett Packard Enterprise incluyen muchos componentes que el propio usuario puede reemplazar (Customer Self Repair, CSR) para minimizar el tiempo de reparación y ofrecer una mayor flexibilidad a la hora de realizar sustituciones de componentes defectuosos. Si, durante la fase de diagnóstico, Hewlett Packard Enterprise (o los proveedores o socios de servicio de Hewlett Packard Enterprise) identifica que una reparación puede llevarse a cabo mediante el uso de un componente CSR, Hewlett Packard Enterprise le enviará dicho componente directamente para que realice su sustitución. Los componentes CSR se clasifican en dos categorías:

- **Obligatorio**—Componentes cuya reparación por parte del usuario es obligatoria. Si solicita a Hewlett Packard Enterprise que realice la sustitución de estos componentes, tendrá que hacerse cargo de los gastos de desplazamiento y de mano de obra de dicho servicio.
- **Opcional**—Componentes cuya reparación por parte del usuario es opcional. Estos componentes también están diseñados para que puedan ser reparados por el usuario. Sin embargo, si precisa que Hewlett Packard Enterprise realice su sustitución, puede o no conllevar costes adicionales, dependiendo del tipo de servicio de garantía correspondiente al producto.

NOTA: Algunos componentes de Hewlett Packard Enterprise no están diseñados para que puedan ser reparados por el usuario. Para que el usuario haga valer su garantía, Hewlett Packard Enterprise pone como condición que un proveedor de servicios autorizado realice la sustitución de estos componentes. Dichos componentes se identifican con la palabra "No" en el catálogo ilustrado de componentes.

Según la disponibilidad y la situación geográfica, los componentes CSR se enviarán para que lleguen a su destino al siguiente día laborable. Si la situación geográfica lo permite, se puede solicitar la entrega en el mismo día o en cuatro horas con un coste adicional. Si precisa asistencia técnica, puede llamar al Centro de asistencia técnica de Hewlett Packard Enterprise y recibirá ayuda telefónica por parte de un técnico. Con el envío de materiales para la sustitución de componentes CSR, Hewlett Packard Enterprise especificará si los componentes defectuosos deberán devolverse a Hewlett Packard Enterprise. En aquellos casos en los que sea necesario devolver algún componente a Hewlett Packard Enterprise, deberá hacerlo en el periodo de tiempo especificado, normalmente cinco días laborables. Los componentes defectuosos deberán devolverse con toda la documentación relacionada y con el embalaje de envío. Si no enviara el componente defectuoso requerido, Hewlett Packard Enterprise podrá cobrarle por el de sustitución. En el caso de todas sustituciones que lleve a cabo el cliente, Hewlett Packard Enterprise se hará cargo de todos los gastos de envío y devolución de componentes y escogerá la empresa de transporte que se utilice para dicho servicio.

Para obtener más información acerca del programa de Reparaciones del propio cliente de Hewlett Packard Enterprise, póngase en contacto con su proveedor de servicios local.

Servicio de garantía exclusivo de componentes

La garantía limitada de Hewlett Packard Enterprise puede que incluya un servicio de garantía exclusivo de componentes. Según las condiciones de este servicio exclusivo de componentes, Hewlett Packard Enterprise le facilitará los componentes de repuesto sin cargo adicional alguno.

Para este servicio de garantía exclusivo de componentes, es obligatoria la sustitución de componentes por parte del usuario (CSR). Si solicita a Hewlett Packard Enterprise que realice la sustitución de estos componentes, tendrá que hacerse cargo de los gastos de desplazamiento y de mano de obra de dicho servicio.

Customer Self Repair

Veel onderdelen in Hewlett Packard Enterprise producten zijn door de klant zelf te repareren, waardoor de reparatieduur tot een minimum beperkt kan blijven en de flexibiliteit in het vervangen van defecte onderdelen groter is. Deze onderdelen worden CSR-onderdelen (Customer Self Repair) genoemd. Als Hewlett Packard Enterprise (of een Hewlett Packard Enterprise Service Partner) bij de diagnose vaststelt dat de reparatie kan worden uitgevoerd met een CSR-onderdeel, verzendt Hewlett Packard Enterprise dat onderdeel rechtstreeks naar u, zodat u het defecte onderdeel daarmee kunt vervangen. Er zijn twee categorieën CSR-onderdelen:

- **Verplicht**—Onderdelen waarvoor reparatie door de klant verplicht is. Als u Hewlett Packard Enterprise verzoekt deze onderdelen voor u te vervangen, worden u voor deze service reiskosten en arbeidsloon in rekening gebracht.
- **Optioneel**—Onderdelen waarvoor reparatie door de klant optioneel is. Ook deze onderdelen zijn ontworpen voor reparatie door de klant. Als u echter Hewlett Packard Enterprise verzoekt deze onderdelen voor u te vervangen, kunnen daarvoor extra kosten in rekening worden gebracht, afhankelijk van het type garanteservice voor het product.

OPMERKING: Sommige Hewlett Packard Enterprise onderdelen zijn niet ontwikkeld voor reparatie door de klant. In verband met de garantievoorzwaarden moet het onderdeel door een geautoriseerde Service Partner worden vervangen. Deze onderdelen worden in de geïllustreerde onderdelencatalogus aangemerkt met "Nee".

Afhankelijk van de leverbaarheid en de locatie worden CSR-onderdelen verzonden voor levering op de eerstvolgende werkdag. Levering op dezelfde dag of binnen vier uur kan tegen meerkosten worden aangeboden, indien dit mogelijk is gezien de locatie. Indien assistentie is gewenst, belt u het Hewlett Packard Enterprise Support Center om via de telefoon ondersteuning van een technicus te ontvangen. Hewlett Packard Enterprise vermeldt in de documentatie bij het vervangende CSR-onderdeel of het defecte onderdeel aan Hewlett Packard Enterprise moet worden geretourneerd. Als het defecte onderdeel aan Hewlett Packard Enterprise moet worden teruggezonden, moet u het defecte onderdeel binnen een bepaalde periode, gewoonlijk vijf (5) werkdagen, retourneren aan Hewlett Packard Enterprise. Het defecte onderdeel moet met de bijbehorende documentatie worden geretourneerd in het meegeleverde verpakkingsmateriaal. Als u het defecte onderdeel niet terugzendt, kan Hewlett Packard Enterprise u voor het vervangende onderdeel kosten in rekening brengen. Bij reparatie door de klant betaalt Hewlett Packard Enterprise alle verzendkosten voor het vervangende en geretourneerde onderdeel en kiest Hewlett Packard Enterprise zelf welke koerier/transportonderneming hiervoor wordt gebruikt.

Neem contact op met een Service Partner voor meer informatie over het Customer Self Repair programma van Hewlett Packard Enterprise.

Garanteservice "Parts Only"

Het is mogelijk dat de Hewlett Packard Enterprise garantie alleen de garanteservice "Parts Only" omvat. Volgens de bepalingen van de Parts Only garanteservice zal Hewlett Packard Enterprise kosteloos vervangende onderdelen ter beschikking stellen.

Voor de Parts Only garanteservice is vervanging door CSR-onderdelen verplicht. Als u Hewlett Packard Enterprise verzoekt deze onderdelen voor u te vervangen, worden u voor deze service reiskosten en arbeidsloon in rekening gebracht

Reparo feito pelo cliente

Os produtos da Hewlett Packard Enterprise são projetados com muitas peças para reparo feito pelo cliente (CSR) de modo a minimizar o tempo de reparo e permitir maior flexibilidade na substituição de peças com defeito. Se, durante o período de diagnóstico, a Hewlett Packard Enterprise (ou fornecedores/parceiros da Hewlett Packard Enterprise) concluir que o reparo pode ser efetuado pelo uso de uma peça CSR, a Hewlett Packard Enterprise enviará a peça diretamente ao cliente. Há duas categorias de peças CSR:

- **Obrigatória**—Peças cujo reparo feito pelo cliente é obrigatório. Se desejar que a Hewlett Packard Enterprise substitua essas peças, serão cobradas as despesas de transporte e mão-de-obra do serviço.

- **Opcional**—Peças cujo reparo feito pelo cliente é opcional. Essas peças também são projetadas para o reparo feito pelo cliente. No entanto, se desejar que a Hewlett Packard Enterprise as substitua, pode haver ou não a cobrança de taxa adicional, dependendo do tipo de serviço de garantia destinado ao produto.

OBSERVAÇÃO: Algumas peças da Hewlett Packard Enterprise não são projetadas para o reparo feito pelo cliente. A fim de cumprir a garantia do cliente, a Hewlett Packard Enterprise exige que um técnico autorizado substitua a peça. Essas peças estão identificadas com a marca "No" (Não), no catálogo de peças ilustrado.

Conforme a disponibilidade e o local geográfico, as peças CSR serão enviadas no primeiro dia útil após o pedido. Onde as condições geográficas permitirem, a entrega no mesmo dia ou em quatro horas pode ser feita mediante uma taxa adicional. Se precisar de auxílio, entre em contato com o Centro de suporte técnico da Hewlett Packard Enterprise para que um técnico o ajude por telefone. A Hewlett Packard Enterprise especifica nos materiais fornecidos com a peça CSR de reposição se a peça com defeito deve ser devolvida à Hewlett Packard Enterprise. Nos casos em que isso for necessário, é preciso enviar a peça com defeito à Hewlett Packard Enterprise, você deverá enviar a peça com defeito de volta para a Hewlett Packard Enterprise dentro do período de tempo definido, normalmente em 5 (cinco) dias úteis. A peça com defeito deve ser enviada com a documentação correspondente no material de transporte fornecido. Caso não o faça, a Hewlett Packard Enterprise poderá cobrar a reposição. Para as peças de reparo feito pelo cliente, a Hewlett Packard Enterprise paga todas as despesas de transporte e de devolução da peça e determina a transportadora/serviço postal a ser utilizado.

Para obter mais informações sobre o programa de reparo feito pelo cliente da Hewlett Packard Enterprise, entre em contato com o fornecedor de serviços local.

Serviço de garantia apenas para peças

A garantia limitada da Hewlett Packard Enterprise pode incluir um serviço de garantia apenas para peças. Segundo os termos do serviço de garantia apenas para peças, a Hewlett Packard Enterprise fornece as peças de reposição sem cobrar nenhuma taxa.

No caso desse serviço, a substituição de peças CSR é obrigatória. Se desejar que a Hewlett Packard Enterprise substitua essas peças, serão cobradas as despesas de transporte e mão-de-obra do serviço.

カスタマーセルフリペア

修理時間を短縮し、故障部品の交換における高い柔軟性を確保するために、Hewlett Packard Enterprise製品には多数のカスタマーセルフリペア（CSR）部品があります。診断の際に、CSR部品を使用すれば修理ができるとHewlett Packard Enterprise（Hewlett Packard EnterpriseまたはHewlett Packard Enterprise正規保守代理店）が判断した場合、Hewlett Packard Enterpriseはその部品を直接、お客様に発送し、お客様に交換していただきます。CSR部品には以下の2種類があります。

- **必須** - カスタマーセルフリペアが必須の部品。当該部品について、もしもお客様がHewlett Packard Enterpriseに交換作業を依頼される場合には、その修理サービスに関する交通費および人件費がお客様に請求されます。
- **任意** - カスタマーセルフリペアが任意である部品。この部品もカスタマーセルフリペア用です。当該部品について、もしもお客様がHewlett Packard Enterpriseに交換作業を依頼される場合には、お買い上げの製品に適用される保証サービス内容の範囲内においては、別途費用を負担していただくことなく保証サービスを受けることができます。

注：Hewlett Packard Enterprise製品の一部の部品は、カスタマーセルフリペアの対象外です。製品の保証を継続するためには、Hewlett Packard EnterpriseまたはHewlett Packard Enterprise正規保守代理店による交換作業が必須となります。部品カタログには、当該部品がカスタマーセルフリペア除外品である旨が記載されています。

部品供給が可能な場合、地域によっては、CSR部品を翌営業日に届くように発送します。また、地域によっては、追加費用を負担いただくことにより同日または4時間以内に届くように発送することも可能な場合があります。サポートが必要なときは、Hewlett Packard Enterpriseサポートセンターに電話していただければ、技術者が電話でアドバイスします。交換用のCSR部品または同梱物には、故障部品をHewlett Packard Enterpriseに返送する必要があるかどうかが表示されています。故障部品をHewlett Packard Enterpriseに返送する必要がある場合は、指定期限内（通常は5営業日以内）に故障部品をHewlett Packard Enterpriseに返送してください。故障部品を返送する場合は、届いた時の梱包箱に関連書類とともに入れてください。故障部品を返送しない場合、Hewlett Packard Enterpriseから部品費用が請求されます。カスタマーセルフリペアの際には、Hewlett Packard Enterpriseは送料および部品返送費を全額負担し、使用する宅配便会社や運送会社を指定します。

部品のみ保証サービス

Hewlett Packard Enterprise保証サービスには、部品のみ保証サービスが適用される場合があります。このサービスでは、交換部品は無償で提供されます。

部品のみ保証サービスにおいては、CSR部品をお客様により交換作業していただくことが必須となります。当該部品について、もしもお客様がHewlett Packard Enterpriseに交換作業を依頼される場合には、その修理サービスに関する交通費および人件費がお客様のご負担となります。

客户自行维修

Hewlett Packard Enterprise 产品提供许多客户自行维修 (CSR) 部件，以尽可能缩短维修时间和在更换缺陷部件方面提供更大的灵活性。如果在诊断期间 Hewlett Packard Enterprise (或 Hewlett Packard Enterprise 服务提供商或服务合作伙伴) 确定可以通过使用 CSR 部件完成维修，Hewlett Packard Enterprise 将直接把该部件发送给您进行更换。有两类 CSR 部件：

- **强制性的** — 要求客户必须自行维修的部件。如果您请求 Hewlett Packard Enterprise 更换这些部件，则必须为该服务支付差旅费和人工费用。
- **可选的** — 客户可以选择是否自行维修的部件。这些部件也是为客户自行维修设计的。不过，如果您要求 Hewlett Packard Enterprise 为您更换这些部件，则根据为您的产品指定的保修服务类型，Hewlett Packard Enterprise 可能收取或不再收取任何附加费用。

注：某些 Hewlett Packard Enterprise 部件的设计并未考虑客户自行维修。为了满足客户保修的需要，Hewlett Packard Enterprise 要求授权服务提供商更换相关部件。这些部件在部件图解目录中标记为“否”。

CSR 部件将在下一个工作日发运（取决于备货情况和允许的地理范围）。在允许的地理范围内，可在当天或四小时内发运，但要收取额外费用。如果需要帮助，您可以致电 Hewlett Packard Enterprise 技术支持中心，将会有技术人员通过电话为您提供帮助。Hewlett Packard Enterprise 会在随更换的 CSR 部件发运的材料中指明是否必须将有缺陷的部件返还给 Hewlett Packard Enterprise。如果要求您将有缺陷的部件返还给 Hewlett Packard Enterprise，那么您必须在规定的期限内（通常是五 (5) 个工作日）将缺陷部件发给 Hewlett Packard Enterprise。有缺陷的部件必须随所提供的发运材料中的相关文件一起返还。如果未能送还有缺陷的部件，Hewlett Packard Enterprise 可能会要求您支付更换费用。客户自行维修时，Hewlett Packard Enterprise 将承担所有相关运输和部件返回费用，并指定快递商/承运商。

有关 Hewlett Packard Enterprise 客户自行维修计划的详细信息，请与您当地的服务提供商联系。

仅部件保修服务

您的 Hewlett Packard Enterprise 有限保修服务可能涉及仅部件保修服务。根据仅部件保修服务条款的规定，Hewlett Packard Enterprise 将免费提供更换的部件。

仅部件保修服务要求进行 CSR 部件更换。如果您请求 Hewlett Packard Enterprise 更换这些部件，则必须为该服务支付差旅费和人工费用。

客戶自行維修

Hewlett Packard Enterprise 產品設計了許多「客戶自行維修」(CSR) 的零件以減少維修時間，並且使得更換瑕疵零件時能有更大的彈性。如果在診斷期間，Hewlett Packard Enterprise (或 Hewlett Packard Enterprise 服務供應商或維修夥伴) 辨認出此項維修工作可以藉由使用 CSR 零件來完成，則 Hewlett Packard Enterprise 將直接寄送該零件給您作更換。CSR 零件分為兩種類別：

- **強制的** — 客戶自行維修所使用的零件是強制性的。如果您要求 Hewlett Packard Enterprise 更換這些零件，Hewlett Packard Enterprise 將會向您收取此服務所需的外出費用與勞動成本。
- **選購的** — 客戶自行維修所使用的零件是選購的。這些零件也設計用於客戶自行維修之用。不過，如果您要求 Hewlett Packard Enterprise 為您更換，則可能需要也可能不需要負擔額外的費用，端視針對此產品指定的保固服務類型而定。

備註：某些 Hewlett Packard Enterprise 零件沒有消費者可自行維修的設計。為符合客戶保固，Hewlett Packard Enterprise 需要授權的服務供應商更換零件。這些零件在圖示的零件目錄中，被標示為「否」。

基於材料取得及環境允許的情況下，CSR 零件將於下一個工作日以快遞寄送。在環境的允許下當天或四小時內送達，則可能需要額外的費用。若您需要協助，可致電 Hewlett Packard Enterprise 支援中心，會有一位技術人員透過電話來協助您。不論損壞的零件是否必須退回，Hewlett Packard Enterprise 皆會在與 CSR 替換零件一起運送的材料中註明。若要將損壞的零件退回 Hewlett Packard Enterprise，您必須在指定的一段時間內 (通常為五 (5) 個工作天)，將損壞的零件寄回 Hewlett Packard Enterprise。損壞的零件必須與寄送資料中隨附的相關技術文件一併退還。如果無法退還損壞的零件，Hewlett Packard Enterprise 可能要向您收取替換費用。針對客戶自行維修情形，Hewlett Packard Enterprise 將負責所有運費及零件退還費用，並指定使用何家快遞/貨運公司。

如需 Hewlett Packard Enterprise 的 CSR 方案詳細資訊，請連絡您當地的服務供應商。

僅限零件的保固服務

您的「Hewlett Packard Enterprise 有限保固」可能包含僅限零件的保固服務。在僅限零件的保固服務情況下，Hewlett Packard Enterprise 將免費提供替換零件。

針對僅限零件的保固服務，CSR 零件替換是強制性的。如果您要求 Hewlett Packard Enterprise 更換這些零件，Hewlett Packard Enterprise 將會向您收取此服務所需的外出費用與勞動成本。

고객 셀프 수리

Hewlett Packard Enterprise 제품은 수리 시간을 최소화하고 결함이 있는 부품 교체 시 더욱 용동성을 발휘할 수 있도록 하기 위해 고객 셀프 수리(CSR) 부품을 다량 사용하여 설계되었습니다. 진단 기간 동안 Hewlett Packard Enterprise(또는 Hewlett Packard Enterprise 서비스 공급업체 또는 서비스 협력업체)에서 CSR 부품을 사용하여 수리가 가능하다고 판단되면 Hewlett Packard Enterprise는 해당 부품을 바로 사용자에게 보내어 사용자가 교체할 수 있도록 합니다. CSR 부품에는 두 가지 종류가 있습니다.

- 필수 - 고객 셀프 수리가 의무 사항인 필수 부품. 사용자가 Hewlett Packard Enterprise에 이 부품의 교체를 요청할 경우 이 서비스에 대한 출장비 및 작업비가 청구됩니다.
- 선택 사항 - 고객 셀프 수리가 선택 사항인 부품. 이 부품들도 고객 셀프 수리가 가능하도록 설계되었습니다. 하지만 사용자가 Hewlett Packard Enterprise에 이 부품의 교체를 요청할 경우 사용자가 구입한 제품에 해당하는 보증 서비스 유형에 따라 추가 비용 없이 교체가 가능할 수 있습니다.

참고: 일부 Hewlett Packard Enterprise 제품은 고객 셀프 수리가 불가능하도록 설계되었습니다. Hewlett Packard Enterprise는 만족스러운 고객 보증을 위해 공인 서비스 제공업체를 통해 부품을 교체하도록 하고 있습니다. 이러한 부품들은 Illustrated Parts Catalog에 "No"라고 표시되어 있습니다.

CSR 부품은 재고 상태와 지리적 조건이 허용하는 경우 다음 영업일 납품이 가능하도록 배송이 이루어집니다. 지리적 조건이 허용하는 경우 추가 비용이 청구되는 조건으로 당일 또는 4시간 배송이 가능할 수도 있습니다. 도움이 필요하시면 Hewlett Packard Enterprise Support Center로 전화하십시오. 전문 기술자가 전화로 도움을 줄 것입니다. Hewlett Packard Enterprise는 결함이 발생한 부품을 Hewlett Packard Enterprise로 반환해야 하는지 여부를 CSR 교체 부품과 함께 배송된 자료에 지정합니다. 결함이 발생한 부품을 Hewlett Packard Enterprise로 반환해야 하는 경우에는 지정된 기간 내(통상 영업일 기준 5일)에 Hewlett Packard Enterprise로 반환해야 합니다. 이때 결함이 발생한 부품은 제공된 포장 재료에 넣어 관련 설명서와 함께 반환해야 합니다. 결함이 발생한 부품을 반환하지 않는 경우 Hewlett Packard Enterprise가 교체 부품에 대해 비용을 청구할 수 있습니다. 고객 셀프 수리의 경우, Hewlett Packard Enterprise는 모든 운송 및 부품 반환 비용을 부담하며 이용할 운송업체 및 택배 서비스를 결정합니다.

Hewlett Packard Enterprise CSR 프로그램에 대한 자세한 내용은 가까운 서비스 제공업체에 문의하십시오.

부품 제공 보증 서비스

Hewlett Packard Enterprise 제한 보증에는 부품 제공 보증 서비스가 포함될 수 있습니다. 이러한 경우 Hewlett Packard Enterprise는 부품 제공 보증 서비스의 조건에 따라 교체 부품만을 무료로 제공합니다.

부품 제공 보증 서비스 제공 시 CSR 부품 교체는 의무 사항입니다. 사용자가 Hewlett Packard Enterprise에 이 부품의 교체를 요청할 경우 이 서비스에 대한 출장비 및 작업비가 청구됩니다.

Illustrated parts catalog

Subtopics

[Mechanical components](#)

[System components](#)

[Server options](#)

Mechanical components

Hewlett Packard Enterprise continually improves and changes product parts. For complete and current supported spare parts information, see the Hewlett Packard Enterprise PartSurfer website:

<https://www.hpe.com/info/partssurfer>

https://sketchfab.com/models/ebee8046ca764dc1a1d8e68aa97c0c00/embed?ui_infos=0&ui_watermark=0&ui_help=0&ui_vr=0&ui_settings=0&ui_inspector=0&ui_hint=2&ui_color=01a982&ui_theme=dark&autostart=1&camera=0&ui_animations=0

Item	Description
1	Front bezel spare part
2	Front I/O module spare part
3	Front boot device cage assembly spare part
4	Fan cage spare part
5	DIMM guard spare parts
6	Energy pack holder spare part
7	System board handle spare part
8	Left OCP A Slot 14 rail spare part
9	SFF drive blank spare part*
10	LFF drive blank spare part*
11	E3.S drive blank spare part*
12	Drive box blank spare part*
13	Media bay filler panel spare part*
14	Fan blank spare part*
15	DIMM guard spare parts*
16	Cable clamp spare part*
17	Boot device latch spare part*
18	Boot device baffle spare part*
19	Boot device blank spare part*
20	Power supply blank spare part*
21	Tertiary riser slot cover spare part*
22	OCP slot blank spare part*
23	Secondary riser cage blank spare part*
24	Serial port blank spare part*

Item	Description
25	External fan connector blank spare part*
26	Cable management arm spare part*
27	Rack rail spare part*

*Not shown

Subtopics

[Front bezel spare part](#)

[Boot device cage assembly spare part](#)

[Front I/O module spare part](#)

[Fan cage spare part](#)

[DIMM guard spare parts](#)

[Miscellaneous blank spare parts](#)

[Miscellaneous mechanical spare parts](#)

[Drive blank spare parts](#)

[Cable management arm spare part](#)

[Rack rails spare part](#)

Front bezel spare part

Customer self repair: **Mandatory**

Replacement procedure: [Removing and replacing the front bezel](#)

Description	Spare part number
Front bezel	P78893-001

Boot device cage assembly spare part

Customer self repair: **Mandatory**

Replacement procedure: [Removing and replacing the front boot device cage assembly](#)

Description	Spare part number
Front boot device cage assembly, includes: <ul style="list-style-type: none"> • Boot device cage • Front boot device baffle 	P78895-001

Front I/O module spare part

Customer self repair: **Mandatory**

Replacement procedure: [Removing and replacing the front I/O module](#)

Description	Spare part number
Front I/O module	P78892-001

Fan cage spare part

Customer self repair: **Mandatory**

Replacement procedure: [Removing and replacing the fan cage](#)

Description	Spare part number
Fan cage	P52799-001

DIMM guard spare parts

Customer self repair: **Mandatory**

Replacement procedure: [Removing and replacing a DIMM guard](#)

Description	Spare part number
Right DIMM guard	P79343-001
Left DIMM guard	P79342-001

Miscellaneous blank spare parts

Customer self repair: **Mandatory**

Replacement procedure:

- [Removing and replacing the drive box blank](#)
- [Removing and replacing the media bay filler panel](#)
- [Removing and replacing the fan blank](#)
- [Removing and replacing the energy pack holder](#)
- [Removing and replacing the boot device blank](#)
- [Removing and replacing the external fan connector blank](#)
- [Removing and replacing the secondary riser cage blank](#)
- [Removing and removing the tertiary riser slot cover](#)
- [Removing and replacing the OCP slot blank](#)
- [Removing and replacing the serial port blank](#)
- [Removing and replacing the cable clamp](#)
- [Removing and replacing the power supply blank](#)

Description	Spare part number
<ul style="list-style-type: none"> • Drive box blank • Media bay filler panel • Fan blank • Energy pack holder 	P52800-001

Description	Spare part number
<ul style="list-style-type: none"> • Boot device blank • External fan connector blank • Secondary riser cage blank • Tertiary riser slot cover 	
<ul style="list-style-type: none"> • OCP slot blank • Serial port blank 	P56489-001
<ul style="list-style-type: none"> • Cable clamp • Power supply blank 	879518-001

Miscellaneous mechanical spare parts

Customer self repair: **Mandatory**

Replacement procedure:

- [Removing and replacing the left OCP A Slot 14 rail](#)
- [Removing and replacing the boot device baffle](#)
- [Removing and replacing the boot device latch](#)
- [Removing and replacing the system board handle](#)

Description	Spare part number
Boot device latch	P58521-001
Boot device baffle	P79345-001
Left OCP A Slot 14 rail	P79344-001
System board handle	P53214-001

Drive blank spare parts

Customer self repair: **Mandatory**

Replacement procedure: [Removing and replacing a drive blank](#)

Description	Spare part number
LFF drive blank	827363-001
SFF drive blank	670033-001
E3.S drive blank	P52488-001

Cable management arm spare part

Customer self repair: **Mandatory**

Replacement procedure: [Removing and replacing the cable management arm](#)

Description	Spare part number
Cable management arm	879160-001

Rack rails spare part

Customer self repair: **Mandatory**

Replacement procedure: [Removing and replacing the rack rails](#)

Description	Spare part number
Server rack rails (left and right)	879448-001

System components

Hewlett Packard Enterprise continually improves and changes product parts. For complete and current supported spare parts information, see the Hewlett Packard Enterprise PartSurfer website:

<https://www.hpe.com/info/partssurfer>

https://sketchfab.com/models/705cdc87cfd484b9923411b0ff7960e/embed?ui_infos=0&ui_watermark=0&ui_help=0&ui_vr=0&ui_settings=0&ui_inspector=0&ui_hint=2&ui_color=01a982&ui_theme=dark&autostart=1&camera=0&ui_animations=0

Item	Description
1	Internal fan spare part
2	Heatsink spare parts
3	Processor spare parts
4	DIMM spare parts
5	Power supply spare parts
6	System battery spare part
7	System board spare part
8	Drive cable spare parts*

*Not shown

Subtopics

[**Internal fan spare part**](#)

[**Heatsink spare parts**](#)

[**Processor spare parts**](#)

[**DIMM spare parts**](#)

[**Power supply spare parts**](#)

[**System battery spare part**](#)

[**System board spare part**](#)

[**Drive cable spare parts**](#)

Internal fan spare part

Customer self repair: **Mandatory**

Replacement procedure: [Fan replacement](#)

Description	Spare part number
Internal fan	P52792-001

Heatsink spare parts

[Customer self repair:](#) **Optional**

Replacement procedure: [Heatsink replacement](#)

Description	Spare part number
Standard heatsink	P73107-001
Performance heatsink	P73108-001

Processor spare parts

[Customer self repair:](#) **Optional**

Replacement procedure: [Processor replacement](#)

Description	Spare part number
Intel Xeon 6500 Series Processors with Performance Cores (P-cores)	—
Intel Xeon 6505P, 2.20 GHz, 12C, 150 W	P80285-001
Intel Xeon 6507P, 3.50 GHz, 8C, 150 W	P80286-001
Intel Xeon 6515P, 2.40 GHz, 16C, 150 W	P80288-001
Intel Xeon 6517P, 3.20 GHz, 16C, 190 W	P80289-001
Intel Xeon 6520P, 2.40 GHz, 24C, 210 W	P80278-001
Intel Xeon 6527P, 3.00 GHz, 24C, 255 W	P80280-001
Intel Xeon 6530P, 2.30 GHz, 32C, 225 W	P80281-001
Intel Xeon 6700 Series Processors with Performance Cores (P-cores)	—

Description	Spare part number
Intel Xeon 6725P, 3.7 GHz, 16C, 235 W	P87398-001
Intel Xeon 6730P, 2.50 GHz, 32C, 250 W	P78738-001
Intel Xeon 6736P, 2 GHz, 36C, 205 W	P80283-001
Intel Xeon 6737P, 2.9 GHz, 32C, 270 W	P80284-001
Intel Xeon 6740P, 2.10 GHz, 48C, 270 W	P78691-001
Intel Xeon 6745P, 3.1 GHz, 32C, 300 W	P82218-001
Intel Xeon 6747P, 2.70 GHz, 48C, 330 W	P78693-001
Intel Xeon 6760P, 2.20 GHz, 64C, 330 W	P78694-001
Intel Xeon 6767P, 2.40 GHz, 64C, 350 W	P78696-001
Intel Xeon 6787P, 2.00 GHz, 86C, 350 W	P78698-001

DIMM spare parts

Customer self repair: **Mandatory**

Replacement procedure: [Removing and replacing a DIMM](#)

Description	Spare part number
16 GB, single-rank x8 PC5-6400B-R	P71254-001
32 GB, dual-rank x8 PC5-6400B-R	P71255-001
64 GB, dual-rank x4 PC5-6400B-R	P71256-001
96 GB, dual-rank x4 PC5-6400B-R	P71257-001
128 GB, dual-rank x4 PC5-6400B-R	P71258-001
256 GB, quad-rank x4 PC5-6400B-R 3DS	P75947-001

Power supply spare parts

Customer self repair: **Mandatory**

Replacement procedure: [Flexible Slot power supply replacement](#)

Description	Spare part number
HPE 800 W Flex Slot Platinum Hot-plug Low Halogen Power Supply	P39385-001
HPE 1000 W Flex Slot Titanium Hot-plug Power Supply	P44412-001
HPE 1600 W Flex Slot Platinum Hot-plug Low Halogen Power Supply	P39384-001
HPE 1600 W Flex Slot -48 VDC Hot-plug Power Supply	P18510-001
HPE 1800-2200 W Flex Slot Titanium Power Supply	P47163-001

System battery spare part

Customer self repair: **Mandatory**

Replacement procedure: [Removing and replacing the system battery](#)

Description	Spare part number
3.0-V lithium battery coin (CR2032)	319603-001

System board spare part

Customer self repair: **Optional**

Replacement procedure: [System board replacement](#)

Description	Spare part number
System board	P77347-001

Drive cable spare parts

Customer self repair: **Mandatory**

Description and PN	Spare part number
4 LFF SAS/SATA drive controller cable from Box 3 for type-p controller: P45300-001	P52803-001
8 LFF SAS/SATA drive controller cable from Box 2 for type-p controller: P45301-001	P52803-001
4 LFF SAS/SATA drive controller cable from Box 3 for type-o controller: P49936-001	P52804-001
4/8 LFF SAS/SATA drive controller cable from Box 2 for type-o controller: P45306-001	P52804-001
8/16 SFF SAS/SATA drive controller cable for type-o controller: P45304-001	P52808-001
8/16 SFF SAS/SATA drive controller cable from Box 1/2 for type-p controller: P45296-001	P52805-001
8/16 SFF SAS/SATA drive controller cable from Box 2/3 for type-p controller: P45297-001	P52806-001
8/16/24 SFF NVMe x2 drive direct attach cable: P75563-001	P77391-001
8/16 SFF NVMe x4 drive direct attach cable: P75564-001	P76754-001
8 SFF NVMe x4 drive controller cabling in Box 3: MR932i-p in the primary riser: P76443-001	P77389-001
24 SFF NVMe x2 drive controller cabling: MR932i-p in the primary and secondary riser: P78631-001	P80139-001
12 E3.S drive direct attach cable for Box 3: P75568-001	P76755-001
12 E3.S E3.S drive controller cabling in Box 3: MR932i-p controller in the primary riser: P75570-001	P84599-001
LFF/SFF drive power cable: P75906-001	P76905-001
E3.S drive power cable: P75277-001	P76895-001

Server options

Hewlett Packard Enterprise continually improves and changes product parts. For complete and current supported spare parts information, see the Hewlett Packard Enterprise PartSurfer website:

<https://www.hpe.com/info/partssurfer>

https://sketchfab.com/models/621267b001534ed694acdaa888fbc8fc/embed?ui_infos=0&ui_watermark=0&ui_help=0&ui_vr=0&ui_settings=0&ui_inspector=0&ui_hint=2&ui_color=01a982&ui_theme=dark&autostart=1&camera=0&ui_animations=0

Item	Description
1	SFF hot-plug drive For more information on the removal and replacement procedures, see Removing and replacing a hot-plug drive .
2	8 SFF drive backplane spare part
3	M.2 SSD For more information on the removal and replacement procedures, see: Removing and replacing a boot device drive
4	M.2 SSD carrier spare part
5	Boot device cage assembly spare part
6	Tertiary riser spare part
7	Chassis intrusion detection switch spare part
8	M.2 SSD For more information on the removal and replacement procedures, see: Removing and replacing a boot device drive
9	M.2 SSD carrier spare part
10	Boot device cage assembly spare part
11	PCIe5 riser spare parts
12	Serial port cable spare part
13	External fan spare part
14	E3.S hot-plug drive* For more information on the removal and replacement procedures, see Removing and replacing a hot-plug drive .

Item	Description
15	LFF hot-plug drive* For more information on the removal and replacement procedures, see Removing and replacing a hot-plug drive .
16	4 LFF drive backplane spare part*
17	E3.S drive backplane spare part*
18	Optical drive* For more information on the removal and replacement procedures, see Removing and replacing the optical drive .
19	SAS LTO tape drive* For more information on the removal and replacement procedures, see Removing and replacing a SAS LTO tape drive .
20	Energy pack spare parts*
21	HPE MR type-p PCIe storage controller spare parts*
22	HPE MR type-o storage controller spare parts*
23	OCP NIC adapter* For more information on the removal and replacement procedures, see Removing and replacing the OCP NIC adapter .
24	Media device cable spare part*
25	OCP bandwidth upgrade cable spare parts*
26	GPU auxiliary power cable spare part*

*Not shown

Subtopics

[Drive backplane spare parts](#)

[Chassis intrusion detection switch spare part](#)

[HPE NS204i-u Boot Device V2 spare parts](#)

[Serial port cable spare part](#)

[Riser board spare parts](#)

[External fan spare parts](#)

[Energy pack spare parts](#)

[Storage controller spare parts](#)

[Media device cable spare part](#)

[OCP bandwidth upgrade cable spare parts](#)

[Tertiary riser signal cable spare part](#)

[GPU auxiliary power cable spare part](#)

Drive backplane spare parts

Customer self repair: **Mandatory**

Replacement procedure:

- [Removing and replacing the 4 LFF drive backplane](#)
- [Removing and replacing the 8 SFF drive backplane](#)
- [Removing and replacing the 4 E3.S drive backplane](#)

Description	Spare part number
4 LFF 12G x1 SAS / SATA UBM3 LP	P48075-001
8 SFF 24G x1 U.3 NVMe / SAS UBM3 BC	P39781-001
8 SFF 24G x1 U.3 NVMe / SAS UBM6 BC	P62070-001
8 SFF 24G x4 U.3 NVMe / SAS UBM3 BC	P39780-001
8 SFF 24G x4 U.3 NVMe / SAS UBM6 BC	P62065-001
4 E3.S 32G x4 NVMe UMB10 EC	P73067-001

Chassis intrusion detection switch spare part

Customer self repair: **Mandatory**

Replacement procedure: [Removing and replacing the chassis intrusion detection switch](#)

Description and PN	Spare part number
Chassis intrusion detection switch: P47751-001	P52442-001

HPE NS204i-u Boot Device V2 spare parts

Customer self repair: **Mandatory**

Replacement procedure: [HPE NS204i-u Boot Device V2 replacement](#)



IMPORTANT

For successful RAID 1 configuration, verify that the boot device SSDs have the same model number and firmware version:

- In the iLO web interface, see the **Storage** page.
- In UEFI System Utilities, see **System Configuration > HPE NS204i Boot Controller > Physical Device Information**.

Configurations with SSDs from different manufacturers are not supported.

Description and cable PN	Spare part number
Boot device V2 cage assembly	P78425-001
M.2 SSD carrier	P59777-001
480 GB NVMe RI M.2 SV 2280 SSD	P69616-001
480 GB NVMe RI M.2 2280 V2 MV SSD	P80342-001
960 GB NVMe RI M.2 2280 V2 MV SSD	P80343-001
960 GB NVMe RI M.2 2280 MV SED SSD	P80345-001
Front boot device SlimSAS cable: P74730-001	P76890-001
Front boot device power cable: P48956-001	P56479-001
Rear boot device SlimSAS cable: P72024-001	P74017-001
Rear boot device power cable: P54089-001	P52811-001

Serial port cable spare part

Customer self repair: **Mandatory**

Replacement procedure: [Removing and replacing the serial port cable](#)

Description and PN	Spare part number
Serial port cable: P45623-001	P56488-001

Riser board spare parts

Customer self repair: **Mandatory**

Replacement procedure: Removing and replacing the primary/secondary riser board

Description	Spare part number
PCIe5 4 x8 slots riser	P52790-001
PCIe5 2 x16 slots riser	P52791-001

Customer self repair: **Optional**

Replacement procedure: Removing and replacing the tertiary riser board

Description	Spare part number
Tertiary riser	P53213-001

External fan spare parts

Customer self repair: **Mandatory**

Replacement procedure:

- Removing and replacing the external fan
- Removing and replacing the external fan cable

Description	Spare part number
External fan spare kit, includes: <ul style="list-style-type: none">• External fan• External fan cable (PN: P45291-001)	P52813-001

Energy pack spare parts

Customer self repair: **Mandatory**

Replacement procedure: [Removing and replacing the energy pack](#)

Description and cable PN	Spare part number
HPE 96 W Smart Storage Battery with 260 mm (10.24 in) cable	878644-001
HPE 12 W Smart Storage Hybrid Capacitor with 260 mm (10.24 in) cable	P07474-001
HPE 16 W Smart Storage Hybrid Capacitor with 260 mm (10.24 in) cable	P66826-001
Energy pack extension cable: 873905-001	P52804-001

Storage controller spare parts

Customer self repair: **Optional**

Replacement procedure:

- [Removing and replacing a type-o storage controller](#)
- [Removing and replacing a type-p storage controller](#)

Description	Spare part number
HPE type-o controllers	—
HPE MR216i-o Gen11 controller	P47954-001
HPE MR408i-o Gen11 controller	P58543-001
HPE MR416i-o Gen11 controller	P47952-001
HPE type-p controllers	—
HPE MR216i-p Gen11 controller	P47953-001
HPE MR416i-p Gen11 controller	P47951-001
HPE MR932i-p controller	P75933-001

Media device cable spare part

Customer self repair: **Mandatory**

Cable description and PN	Spare part number
LTO SlimSAS storage cable to type-o controller: P49 007-001	P75595-001
LTO SlimSAS storage cable to type-p controller: P49 006-001	P68552-001
LTO power splitter cable: P45303-001	P52812-001
Optical drive cable: P73776-002	P76888-001

OCP bandwidth upgrade cable spare parts

Customer self repair: **Mandatory**

Description and PN	Spare part number
Slot 15 OCP B enablement cable: P74891-001	P76893-001
Slot 14 OCP A bandwidth upgrade cable: P74890-001	P76892-001
Dual OCP slot upgrade cable: P74889-001	P76891-001

Tertiary riser signal cable spare part

Customer self repair: **Mandatory**

Description and PN	Spare part number
Tertiary riser signal cable: P79969-001	P81005-001

GPU auxiliary power cable spare part

Customer self repair: **Mandatory**

Description and PN	Spare part number
16-pin GPU auxiliary power Y-cable: P58422-001	P59963-001

Removal and replacement procedures

Subtopics

Safety considerations

Preparation procedures

Removing and replacing the front bezel

Removing and replacing a hot-plug LFF / SFF / E3.S drive

Removing and replacing the drive box blank

Removing and replacing a drive blank

Removing and replacing the media bay filler panel

Flexible Slot power supply replacement

Removing and replacing a power supply blank

Removing and replacing the cable management arm

Removing and replacing the rack rails

Media device replacement

Removing and replacing the front I/O module

Drive backplane replacement

Fan replacement

Removing and replacing the fan blank

Removing and replacing the fan cage

Removing and replacing the system board handle

Removing and replacing a DIMM

Removing and replacing a DIMM guard

Removing and replacing the chassis intrusion detection switch

Removing and replacing a cable clamp

HPE NS204i-u Boot Device V2 replacement

Removing and replacing the front boot device cage assembly

Removing and replacing the boot device baffle

Removing and replacing the boot device latch

Removing and replacing the boot device blank

Removing and replacing the energy pack

Removing and replacing the energy pack holder

Expansion card replacement

Riser board replacement

Removing and replacing a type-o storage controller

Removing and replacing the OCP NIC adapter

Removing and replacing an OCP slot blank

Removing and replacing the left OCP A Slot 14 rail

Removing and replacing the secondary riser cage blank

Removing and replacing the external fan connector blank

Removing and replacing the external fan cable

Removing and replacing the serial port cable

Removing and replacing the serial port blank

Removing and replacing the tertiary riser slot cover

Heatsink replacement

Processor replacement

System board replacement

System battery replacement

Safety considerations

Before performing service procedures, review all the safety information.

- [Electrostatic discharge](#)
- [Symbols on equipment](#)
- [Rack warnings and cautions](#)
- [Server warnings and cautions](#)

Subtopics

Electrostatic discharge

Symbols on equipment

Rack warnings and cautions

Server warnings and cautions

Electrostatic discharge

Be aware of the precautions you must follow when setting up the system or handling components. A discharge of static electricity from a finger or other conductor may damage system boards or other static-sensitive devices. This type of damage may reduce the life expectancy of the system or component.

To prevent electrostatic damage:

- Avoid hand contact by transporting and storing products in static-safe containers.
- Keep electrostatic-sensitive parts in their containers until they arrive at static-free workstations.
- Place parts on a grounded surface before removing them from their containers.
- Avoid touching pins, leads, or circuitry.
- Always be properly grounded when touching a static-sensitive component or assembly. Use one or more of the following methods when handling or installing electrostatic-sensitive parts:
 - Use a wrist strap connected by a ground cord to a grounded workstation or computer chassis. Wrist straps are flexible straps with a minimum of 1 megohm \pm 10 percent resistance in the ground cords. To provide proper ground, wear the strap snug against the skin.
 - Use heel straps, toe straps, or boot straps at standing workstations. Wear the straps on both feet when standing on conductive floors or dissipating floor mats.
 - Use conductive field service tools.
 - Use a portable field service kit with a folding static-dissipating work mat.

If you do not have any of the suggested equipment for proper grounding, have an authorized reseller install the part.

For more information on static electricity or assistance with product installation, contact an authorized reseller.

Symbols on equipment

The following symbols may be placed on equipment to indicate the presence of potentially hazardous conditions:



This symbol in conjunction with any of the following symbols indicates the presence of a potential hazard. The potential for injury exists if warnings are not observed. Consult your documentation for specific details.

該符號與以下任意符號組合使用，指示存在潛在的危險。如果不遵守警告，可能會造成人身傷害。詳細信息請參閱相關文檔。



This symbol indicates the presence of hazardous energy circuits or electric shock hazards. Refer all servicing to qualified personnel.



WARNING

To reduce the risk of injury from electric shock hazards, do not open this enclosure. Refer all maintenance, upgrades, and servicing to qualified personnel.

此符號表明存在危險電路或觸電的危險。所有維修工作應由具有相關資格的人員來完成。

警告：為了減少觸電造成人身傷害的危險，請不要打開此外殼。所有維護、升級和維修工作都應由具有相關資格的人員來完成。



This symbol indicates the presence of electric shock hazards. The area contains no user or field-serviceable parts. Do not open for any reason.



WARNING

To reduce risk of injury from electric shock hazards, do not open this enclosure.

此符號表明存在觸電的危險。在這一區域內沒有用戶可以現場維修的部件。一定不要打開。警告：為了減少觸電造成人身傷害的危險，請不要打開此外殼。



This symbol on an RJ-45 receptacle indicates a Network Interface Connection.



WARNING

To reduce risk of electric shock, fire, or damage to the equipment, do not plug telephone or telecommunications connectors into this receptacle.

RJ-45 插孔上的該符號指示網絡接口連接。

警告：為了減少觸電、火災或設備損壞的危險，不要將電話或電信連接設備插入此插孔。



This symbol indicates the presence of a hot surface or hot component. If this surface is contacted, the potential for injury exists.



WARNING

To reduce the risk of injury from a hot component, allow the surface to cool before touching.

此符號表明表面或組件過熱。如果觸摸此表面，可能會造成人身傷害。警告：為了減少因組件過熱而造成人身傷害的危險，應等到表面降溫後再觸摸。



This symbol indicates the presence of a moving fan blade. If the spinning blades are contacted, the potential for injury exists.



WARNING

Hazardous moving parts. Keep away from moving fan blades. To reduce the risk of injury from a hot component, allow the surface to cool before touching.

此符號表明存在運動風扇葉片的危險。如果觸摸旋轉葉片，可能會造成人身傷害。警告：危險的運動部件。請遠離運動風扇刀片。為減少被高溫組件燙傷的危險，應在表面冷卻之後再接觸。

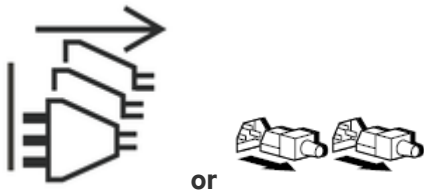

These symbols on power supplies or systems indicate that the equipment is supplied by multiple sources of power.



WARNING

To reduce the risk of injury from electric shock, remove all power cords to completely disconnect power from the system.

電源或系統上的這些符號表明設備由多個電源供電。
警告：為了減少觸電造成人身傷害的危險，應拔下所有電源線插頭，完全斷開系統的電源。



Weight in kg.

Weight in lb.

This symbol indicates that the component exceeds the recommended weight for one individual to handle safely.



WARNING

To reduce the risk of personal injury or damage to the equipment, observe local occupational health and safety requirements and guidelines for manual material handling.

此符號表明組件的重量超出了建議值，一個人無法安全取放。
警告：為了減少人身傷害或設備損壞的危險，應遵守當地有關人工取放物品的職業保健與安全規定及準則。



A discharge of static electricity from a finger or other conductor may damage system boards or other static-sensitive devices. To prevent damage, observe antistatic precautions.

手指或其它導體所釋放的靜電可能損壞主板或其它對靜電敏感的設備。為防止發生損壞，請遵守防靜電預防措施。



These symbols appearing together indicate that the product may have high touch current and that a reliable earth ground must be in place before connecting the equipment.



WARNING

Risk of electric shock due to high touch current. Connect to earth before connecting to supply.



This symbol indicates the presence of a laser device in the product that may exceed Class 1 limits. Refer to the product documentation for more information.

此符號表明在可能會超出 1 類限制的產品中存在激光設備。有關詳細信息，請參閱產品文檔。



This symbol indicates the presence of moving parts inside the product that may present a pinch point if improperly contacted.



WARNING

Hazardous moving parts. Do not insert any tools or any part of your body into the product while it is operating or in any openings.



This symbol indicates the presence of coin cell battery.



WARNING

- **INGESTION HAZARD:** This product contains a button cell or coin battery.
- **DEATH** or serious injury can occur if ingested.
- A swallowed button cell or coin battery can cause Internal Chemical Burns in as little as 2 hours.
- **KEEP** new and used batteries **OUT OF REACH** of **CHILDREN**.
- Seek immediate medical attention if a battery is suspected to be swallowed or inserted inside any part of the body.

Rack warnings and cautions



WARNING

When all components are removed, the server weighs 23.96 kg (58.22 lb). When all components are installed, the server can weigh up to 45.13 kg (99.49 lb).

Before configuring your rack solution, be sure to check the rack manufacturer weight limits and specifications. Failure to do so can result in physical injury or damage to the equipment and the facility.



WARNING

The server is heavy. To reduce the risk of personal injury or damage to the equipment, do the following:

- Observe local occupational health and safety requirements and guidelines for manual material handling.
- Get help to lift and stabilize the product during installation or removal, especially when the product is not fastened to the rails. The server weighs more than 23.96 kg (58.22 lb), so at least two people must lift the server into the rack together. An additional person may be required to help align the server if the server is installed higher than chest level.
- Use caution when installing the server in or removing the server from the rack.
- Adequately stabilize the rack before extending a component outside the rack. Extend only one component at a time. A rack may become unstable if more than one component is extended.
- Do not stack anything on top of rail-mounted component or use it as a work surface when extended from the rack.



WARNING

To reduce the risk of personal injury or damage to the equipment, be sure that:

- The rack has anti-tip measures in place. Such measures include floor-bolting, anti-tip feet, ballast, or a combination as specified by the rack manufacturer and applicable codes.
- The leveling jacks (feet) are extended to the floor.
- The full weight of the rack rests on the leveling jacks (feet).

Server warnings and cautions



WARNING

To reduce the risk of personal injury, electric shock, or damage to the equipment, disconnect the power cord to remove power from the server. Pressing the Power On/Standby button does not shut off system power completely. Portions of the power supply and some internal circuitry remain active until AC power is removed.



WARNING

To reduce the risk of personal injury from hot surfaces, allow the drives and the internal system components to cool before touching them.



WARNING

To reduce the risk of fire or burns after removing the energy pack:

- Do not disassemble, crush, or puncture the energy pack.
- Do not short external contacts.
- Do not dispose of the energy pack in fire or water.
- Do not expose the energy pack to low air pressure as it might lead to explosion or leakage of flammable liquid or gas.
- Do not expose the energy pack to temperatures higher than 60°C (140°F).

After power is disconnected, battery voltage might still be present for 1s to 160s.



CAUTION

Protect the server from power fluctuations and temporary interruptions with a regulating UPS. This device protects the hardware from damage caused by power surges and voltage spikes and keeps the server in operation during a power failure.



CAUTION

To prevent damage to electrical components, properly ground the server before beginning any installation, removal, or replacement procedure. Improper grounding can cause electrostatic discharge.



CAUTION

To avoid data loss, Hewlett Packard Enterprise recommends that you back up

Preparation procedures

Prerequisites

Before powering down the server for an upgrade, maintenance, or service procedure, perform a backup of critical server data.

About this task

To access components and perform certain upgrade, maintenance, or service procedure, you must perform one or more of the procedures described in this section.

Subtopics

Server data backup

Power down the server

Position the tower server for hardware configuration

Extend the server from the rack

Remove the server from the rack

Remove the access panel

Remove the drive cage

Remove the primary riser cage

Remove the secondary riser cage blank

Remove the secondary riser cage

Remove the energy pack and the energy pack holder

Remove the fan cage bracket

Remove the HPE NS204i-u Boot Device V2 on the power supply cage

Power up the server

Server data backup

To avoid data loss, make sure to back up all server data before installing or removing a hardware option, performing a server maintenance, or a troubleshooting procedure.

Server data in this context refers to information that may be required to return the system to a normal operating environment after completing a hardware maintenance or troubleshooting procedure. This information may include:

- User data files
- User account names and passwords
- Application settings and passwords

- Component drivers and firmware
- TPM recovery key/password
- BIOS configuration settings—Use the backup and restore function in UEFI System Utilities. For more information, see the UEFI user guide (<https://www.hpe.com/support/hpeuefisystemutilities-quicklinks>).
 - Custom default system settings
 - Security passwords including those required for power-on and BIOS admin access, persistent memory, and Server Configuration Lock (for HPE Trusted Supply Chain servers)
 - Server serial number and the product ID
- iLO-related data—Use the iLO backup and restore function. For more information, see the iLO user guide (<https://www.hpe.com/support/hpeilodocs-quicklinks>).
 - iLO license
 - Customer iLO user name, password, and DNS name
 - iLO configuration settings

Power down the server

Before powering down the server for any upgrade or maintenance procedures, perform a backup of critical server data and programs.



IMPORTANT

When the server is in standby mode, auxiliary power is still being provided to the system.

To power down the server, use one of the following methods:

- Press and release the Power On/Standby button.
This method activates a controlled shutdown of applications and the OS before the server enters standby mode. It can also activate a shutdown behavior governed by an OS configuration or policy.
- Press and hold the Power On/Standby button for more than 4 seconds to force the server to enter standby mode.
This method forces the server to enter standby mode without properly exiting applications and the OS. If an application stops responding, you can use this method to force a shutdown.

- Use a virtual power button selection through iLO 7.
This method initiates a controlled remote shutdown of applications and the OS before the server enters standby mode.

Before proceeding, verify that the server is in standby mode by observing that the system power LED is amber.

Position the tower server for hardware configuration

Procedure

1. Rotate the chassis feet inward.

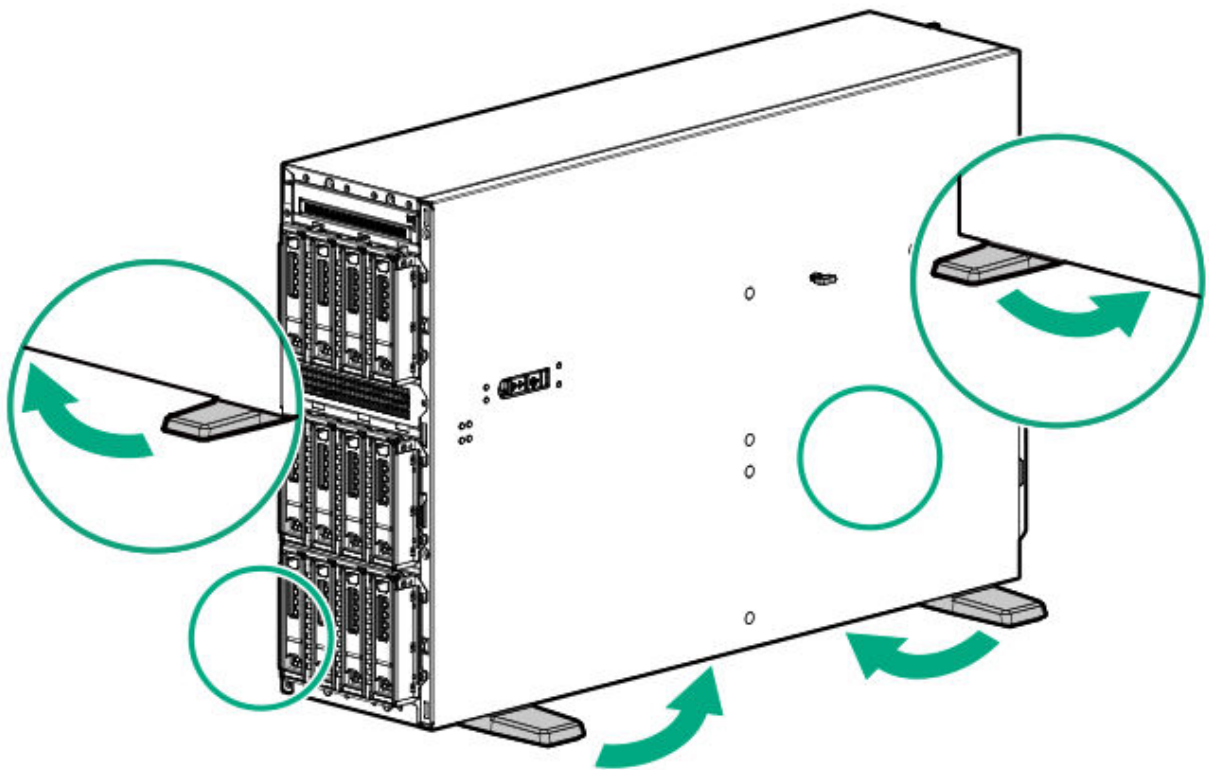

2. Place the server on a flat, level surface with the access panel facing up.

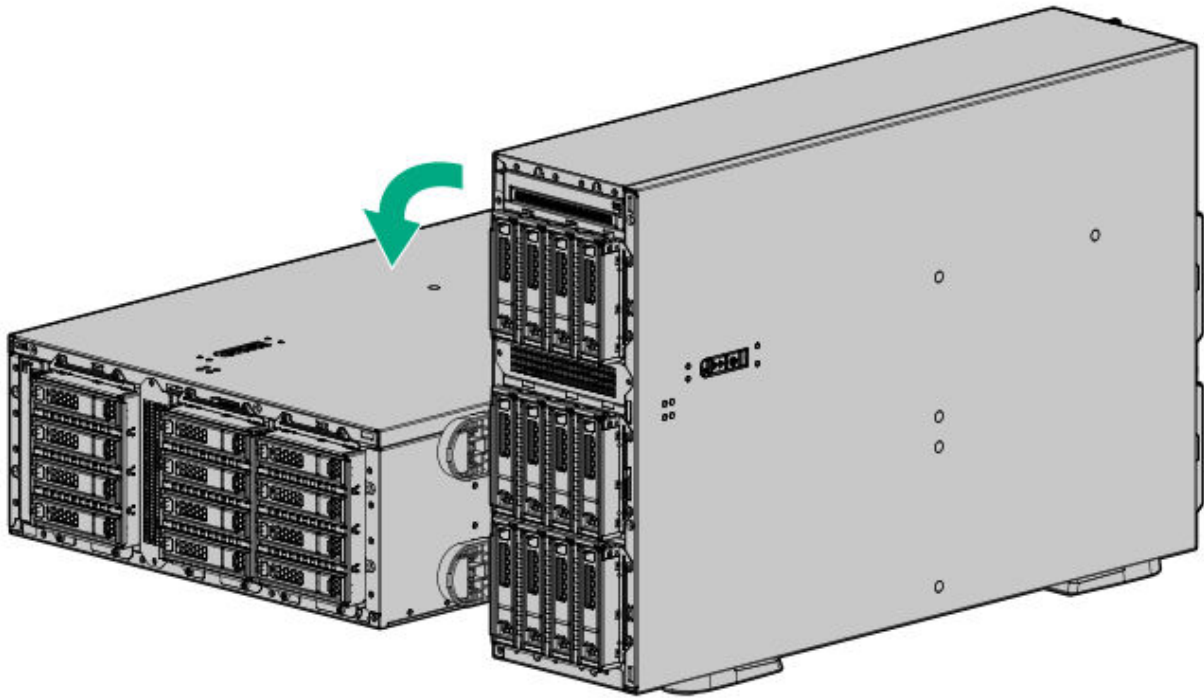

Extend the server from the rack

Prerequisites

Before you perform this procedure, review the [Rack warnings and cautions](#).

Procedure

Slide the server tray out of the rack:

1. Loosen the server tray thumbscrews.
2. Grasp the tray notch and slide the server out of the rack.

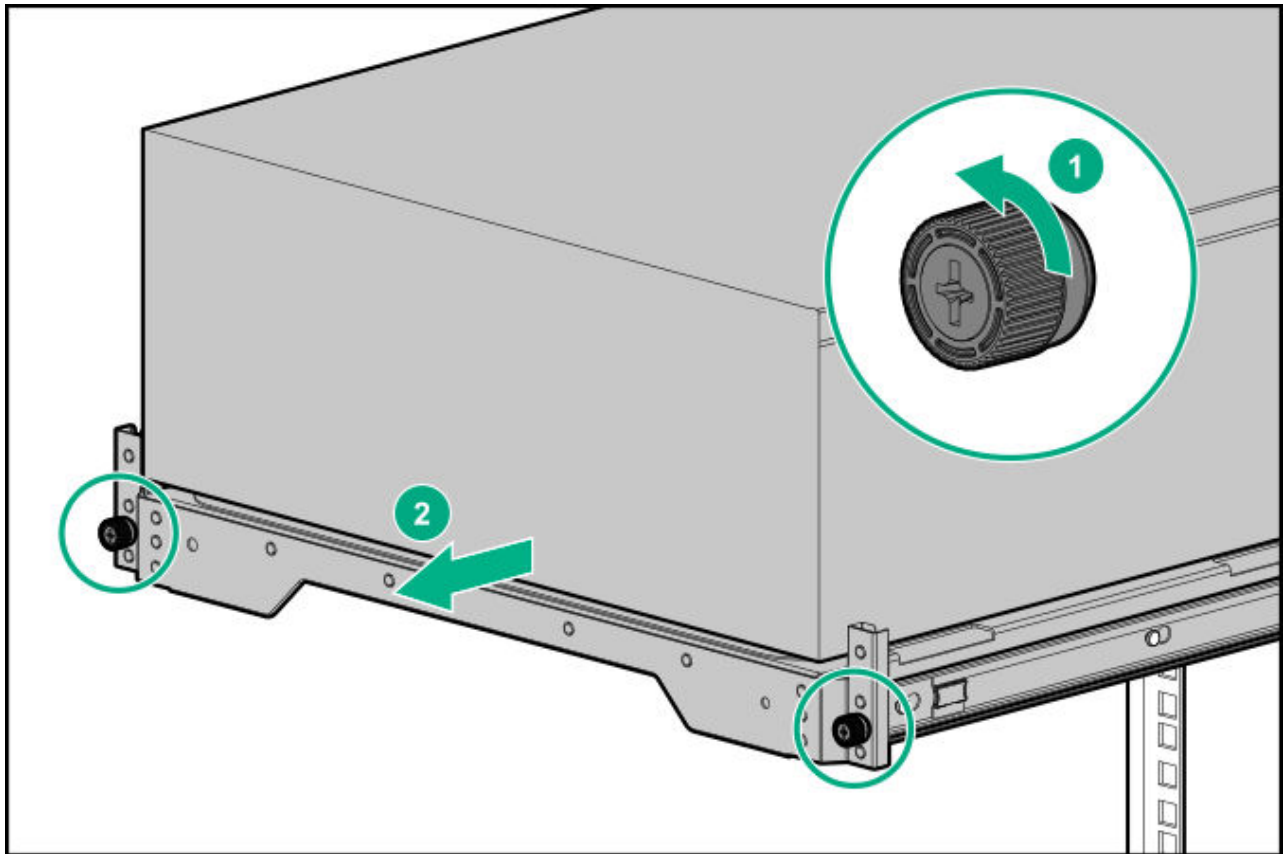

Remove the server from the rack

Prerequisites

- Get help to lift and stabilize the server during removal from the rack. **If the server is installed higher than chest level, additional two people might be required to help remove the server:** One person to support the server weight, and the other two to slide the server out of the rack.
- Before you perform this procedure, review the:
 - [Rack warnings and cautions](#)
 - [Server warnings and cautions](#)
- A fully populated server is heavy. Hewlett Packard Enterprise recommends removing the external chassis components before removing the server from a rack.
- Before you perform this procedure, make sure that you have a T-15 Torx screwdriver available.

Procedure

1. Power down the server.
2. Remove all power:
 - a. Disconnect each power cord from the power source.
 - b. Disconnect each power cord from the server.
3. Disconnect all peripheral cables from the server.
4. If installed, unlock and remove the security padlock and/or the Kensington security lock.
For more information, see the lock documentation.
5. Slide the server tray out of the rack:
 - a. Loosen the server tray thumbscrews.
 - b. Grasp the tray notch and slide the server out of the rack.

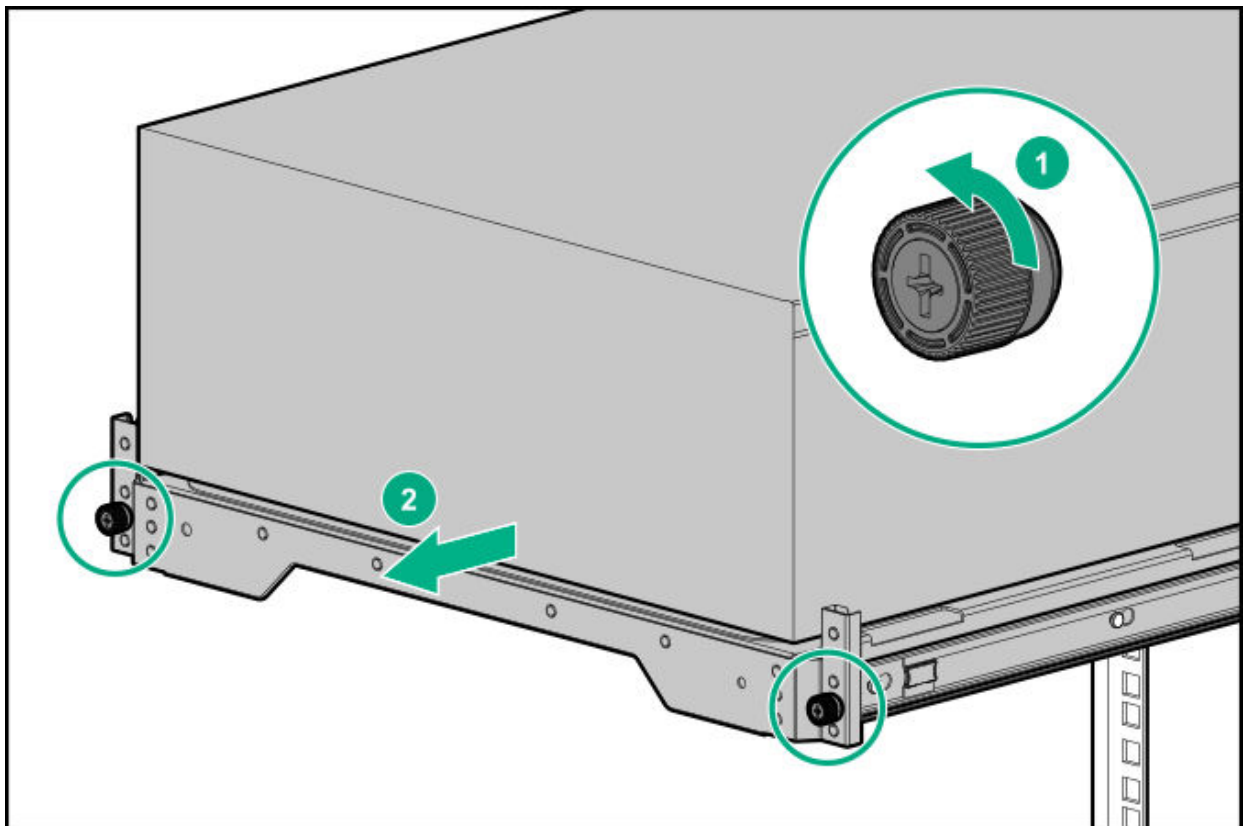

6. Remove the chassis rear bracket screws.

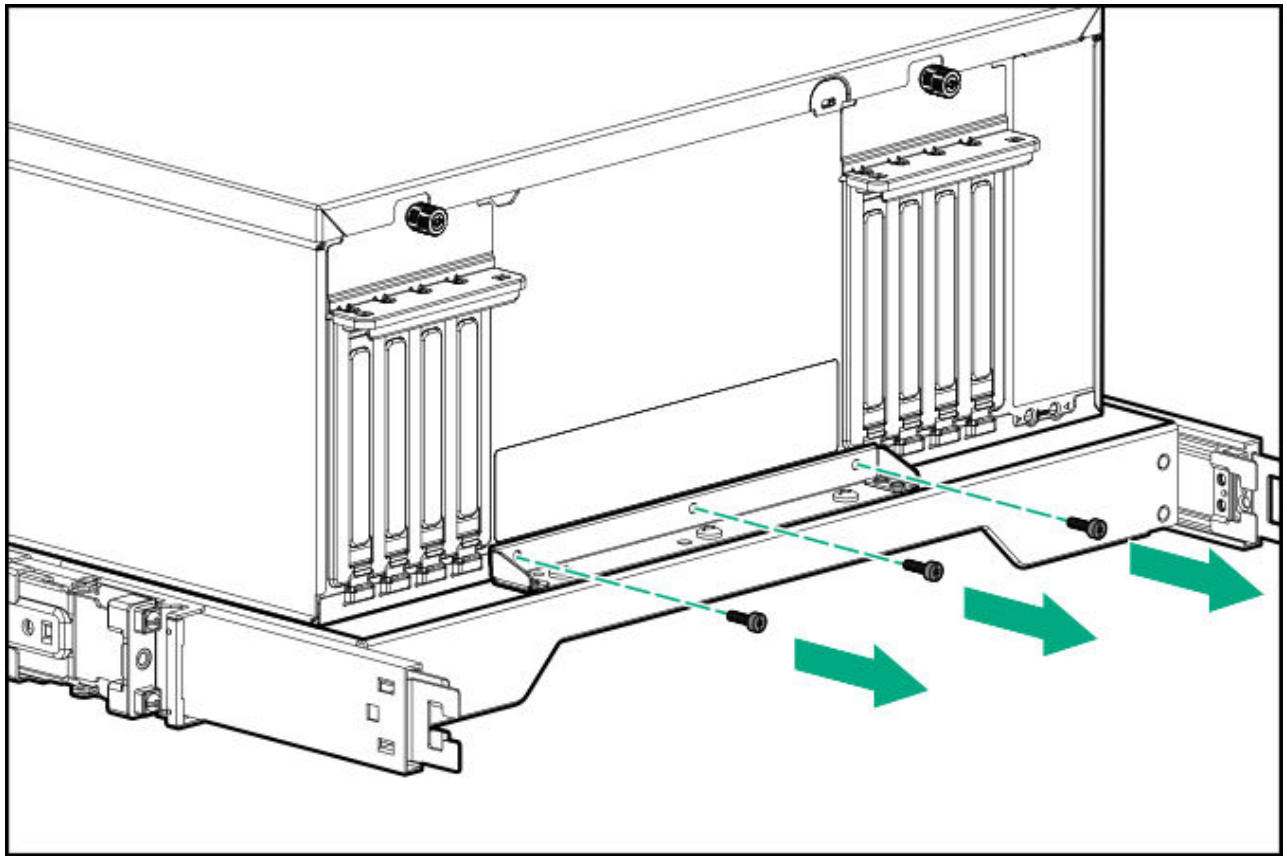

7. Remove the server from the tray.

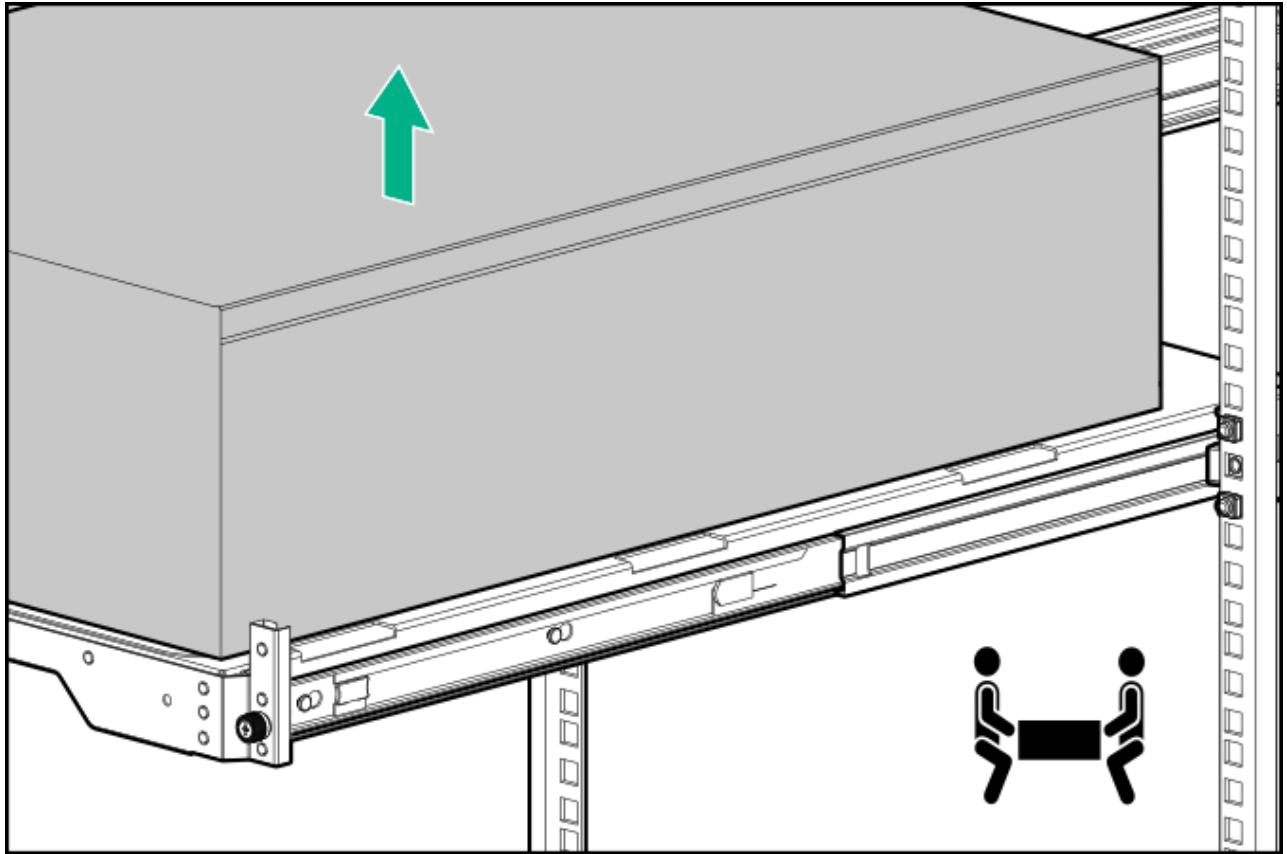

8. Place the server on a flat, level surface with the access panel facing up.

Remove the access panel

Prerequisites

Before you perform this procedure, make sure that you have a T-15 Torx screwdriver available.

About this task



WARNING

To reduce the risk of personal injury from hot surfaces, allow the drives and the internal system components to cool before touching them.



CAUTION

To prevent damage to electrical components, properly ground the server before beginning any installation, removal, or replacement procedure. Improper grounding can cause electrostatic discharge.



CAUTION

To maintain proper system cooling, do not operate the server for long period with the access panel open or removed. Operating the server in this manner results in an improper system airflow. For internal hot-plug component procedures, complete the procedure within 60 seconds. Failure to do so can cause the system temperature to increase and trip the safety threshold. When this happens:

- The health LED flashes amber.
- The operating system gracefully shuts down.

Procedure

1. Power down the server.
2. Remove all power:
 - a. Disconnect each power cord from the power source.
 - b. Disconnect each power cord from the server.
3. Disconnect all peripheral cables from the server.
4. If the server is in tower mode, place the server on a flat, level surface with the access panel facing up.
5. If the server is in rack mode, do one of the following:
 - Extend the server from the rack.
 - Remove the server from the rack.
6. Unlock the front bezel.
7. Remove the access panel:
 - a. If necessary, unlock the access panel latch.

- b. To disengage the access panel from the chassis, press the release button and pull up the latch.
- c. Lift the access panel.

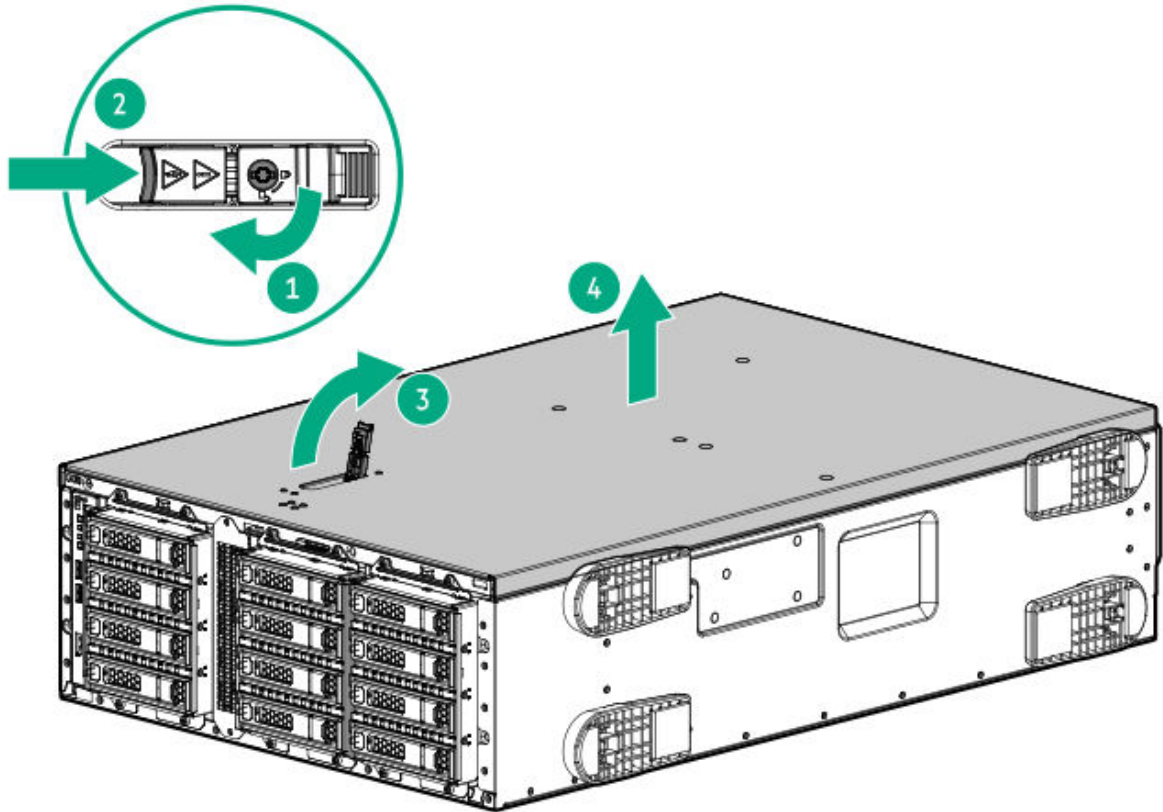

Remove the drive cage

Prerequisites

Before you perform this procedure, make sure that you have a T-15 Torx screwdriver available.

About this task



CAUTION

A discharge of static electricity from a finger or other conductor might damage system boards or other static-sensitive devices. To prevent damage, observe antistatic precautions.



CAUTION

To prevent improper cooling and thermal damage, do not operate the server unless all bays are populated with either a component or a blank.

Procedure

1. Removing and replacing the front bezel.
2. Power down the server.
3. Remove all power:
 - a. Disconnect each power cord from the power source.
 - b. Disconnect each power cord from the server.
4. Disconnect all peripheral cables from the server.
5. Do one of the following:
 - If the server is in tower mode, place the server on a flat, level surface with the access panel facing up.
 - If the server is in rack mode, remove the server from the rack.
6. Remove the access panel.
7. Removing and replacing the fan cage.
8. Disconnect the drive cables.
9. Remove the drive cage:
 - 4 LFF drive:

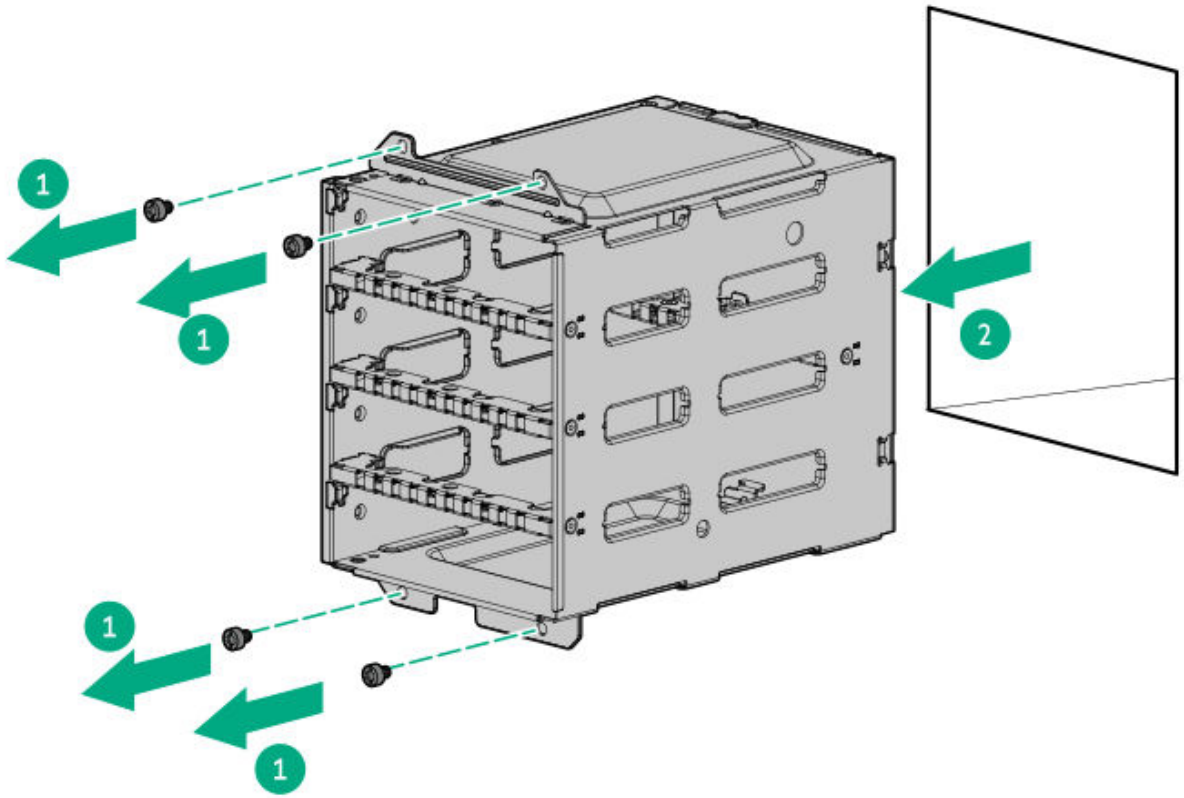

- 8 SFF drive:

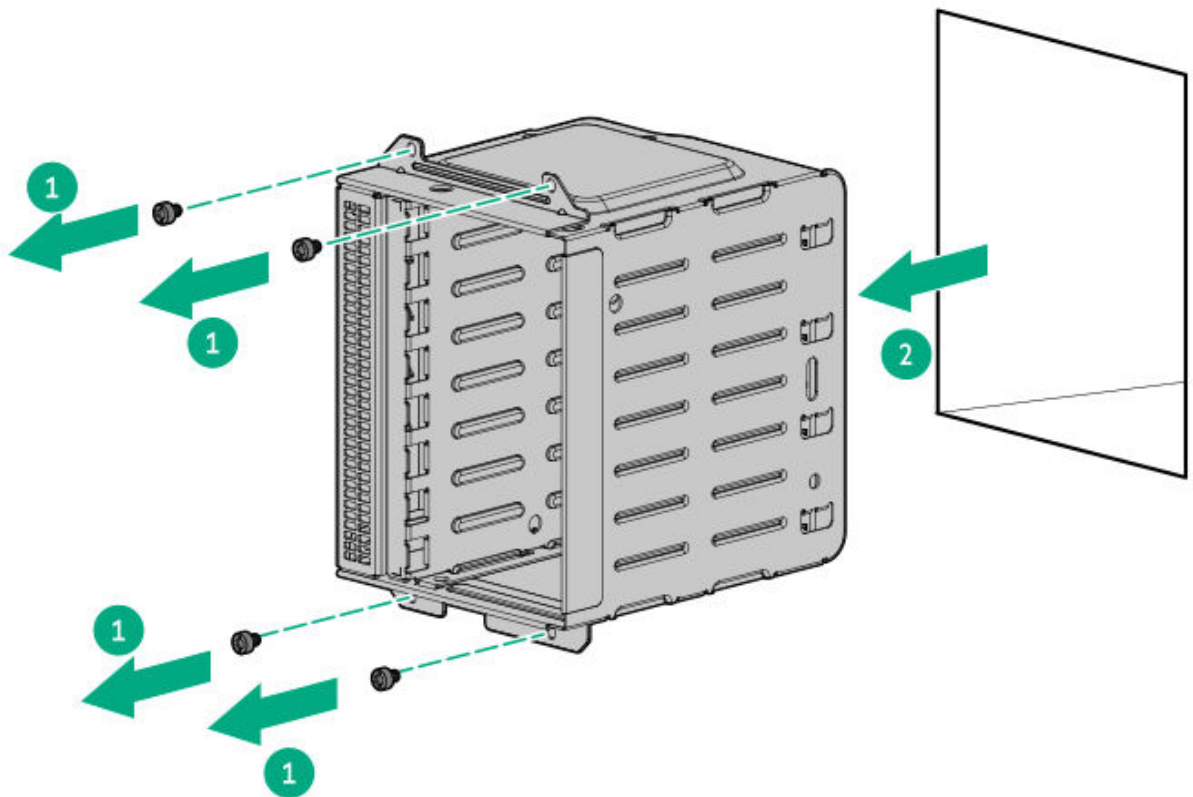

- 12 E3.S drive:

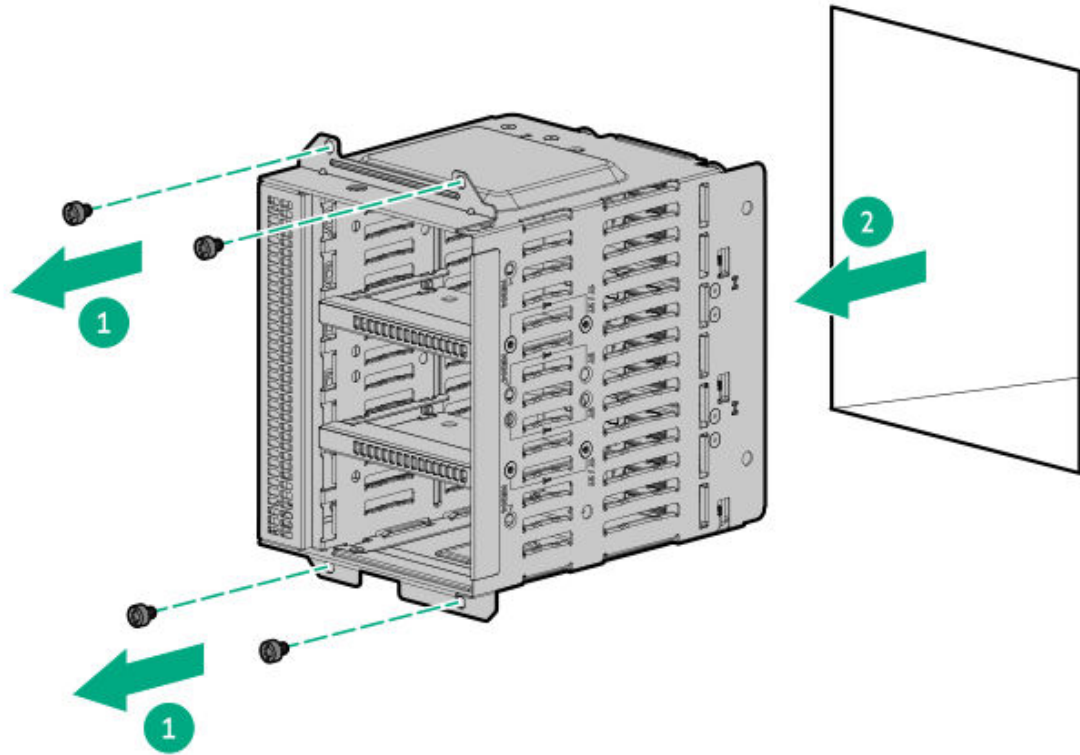

Remove the primary riser cage

About this task

https://sketchfab.com/models/3f84aff558cd485c8bae678486db081e/embed?ui_infos=0&ui_watermark=0&ui_help=0&ui_vr=0&ui_settings=0&ui_inspector=0&ui_hint=2&ui_color=01a982&ui_theme=dark&autostart=1&camera=0&

Procedure

1. Power down the server.
2. Remove all power:
 - a. Disconnect each power cord from the power source.
 - b. Disconnect each power cord from the server.
3. Disconnect all peripheral cables from the server.

4. Do one of the following:
 - If the server is in tower mode, place the server on a flat, level surface with the access panel facing up.
 - If the server is in rack mode, remove the server from the rack.
5. Unlock the front bezel.
6. Remove the access panel.
7. If an expansion card with internal cables is installed on the riser, disconnect all cables from the expansion card.
8. Remove the primary riser cage:
 - a. Release the half-turn spring latch.
 - b. Lift the riser cage off the system board.

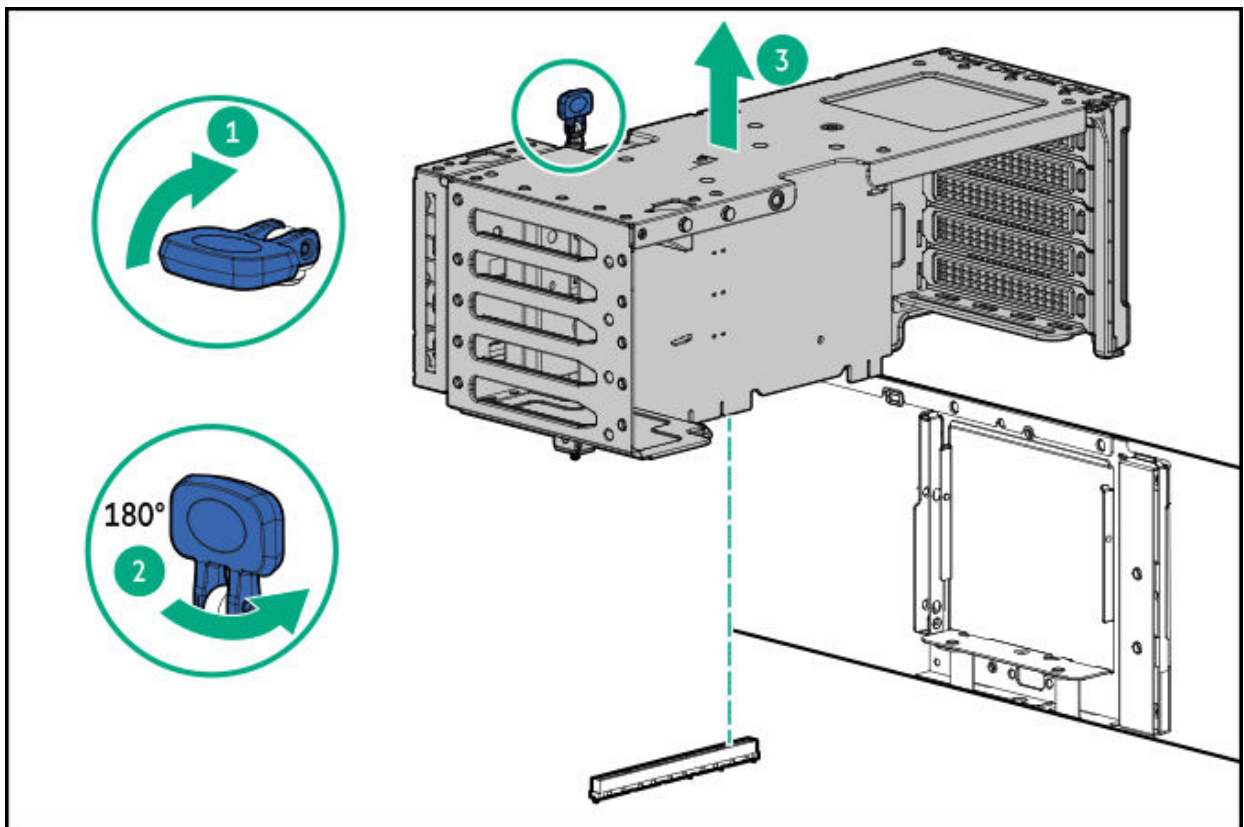

Remove the secondary riser cage blank

Prerequisites

Before you perform this procedure, make sure that you have a T-10 Torx screwdriver available.

About this task



CAUTION

To prevent improper cooling and thermal damage, do not operate the server unless all bays are populated with either a component or a blank.

Procedure

1. Power down the server.
2. Remove all power:
 - a. Disconnect each power cord from the power source.
 - b. Disconnect each power cord from the server.
3. Disconnect all peripheral cables from the server.
4. Do one of the following:
 - If the server is in tower mode, place the server on a flat, level surface with the access panel facing up.
 - If the server is in rack mode, remove the server from the rack.
5. Unlock the front bezel.
6. Remove the access panel.
7. Remove the secondary riser cage blank.

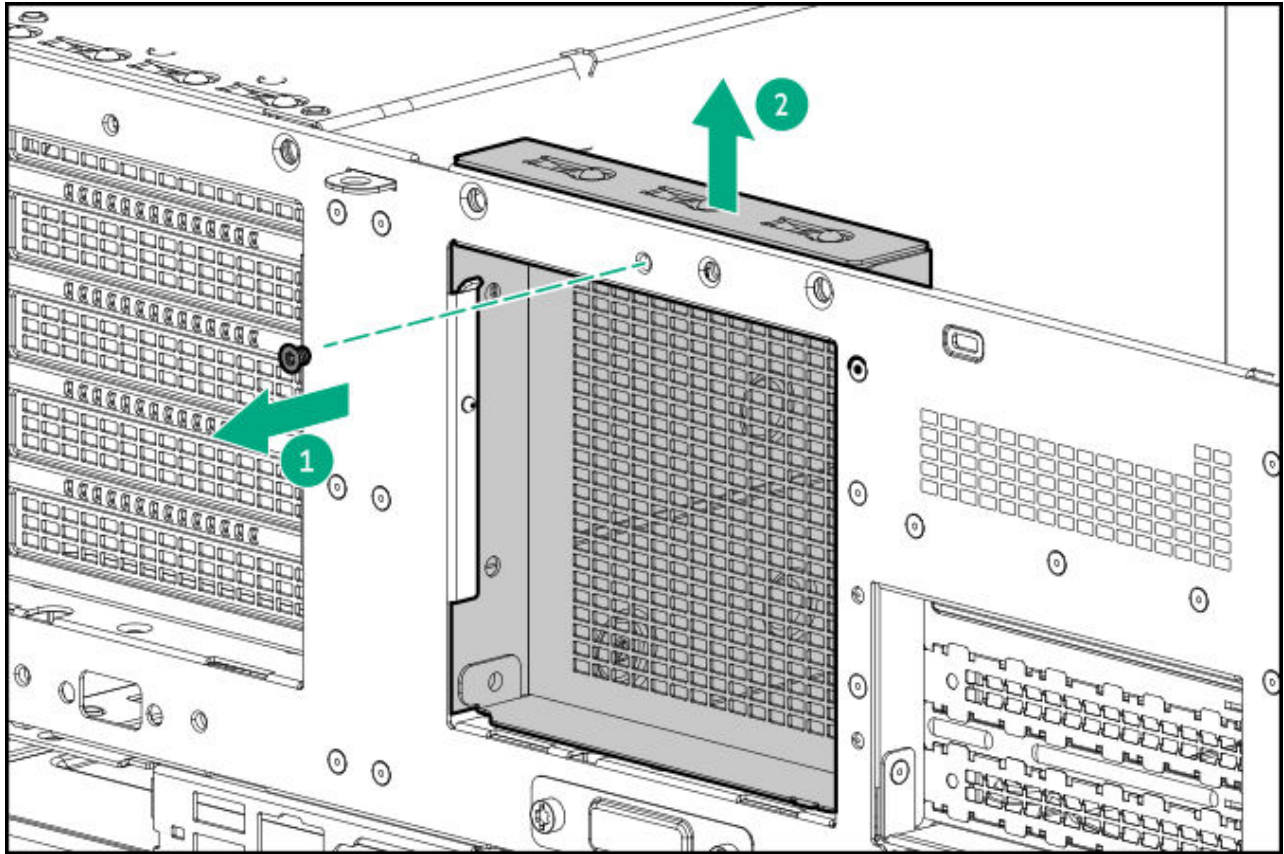

Remove the secondary riser cage

About this task

https://sketchfab.com/models/3f84aff558cd485c8bae678486db081e/embed?ui_infos=0&ui_watermark=0&ui_help=0&ui_vr=0&ui_settings=0&ui_inspector=0&ui_hint=2&ui_color=01a982&ui_theme=dark&autostart=1&camera=0&

Procedure

1. Power down the server.
2. Remove all power:
 - a. Disconnect each power cord from the power source.
 - b. Disconnect each power cord from the server.
3. Disconnect all peripheral cables from the server.

4. Do one of the following:
 - If the server is in tower mode, place the server on a flat, level surface with the access panel facing up.
 - If the server is in rack mode, remove the server from the rack.
5. Unlock the front bezel.
6. Remove the access panel.
7. If an expansion card with internal cables is installed on the riser, disconnect all cables from the expansion card.
8. If installed, remove the expansion card from the tertiary riser:
 - a. If installed, remove the following components:
 - Boot device
 - Energy pack and energy pack holder
 - b. Loosen the stabilizer bracket captive screw, and then pull the stabilizer bracket from the expansion card.

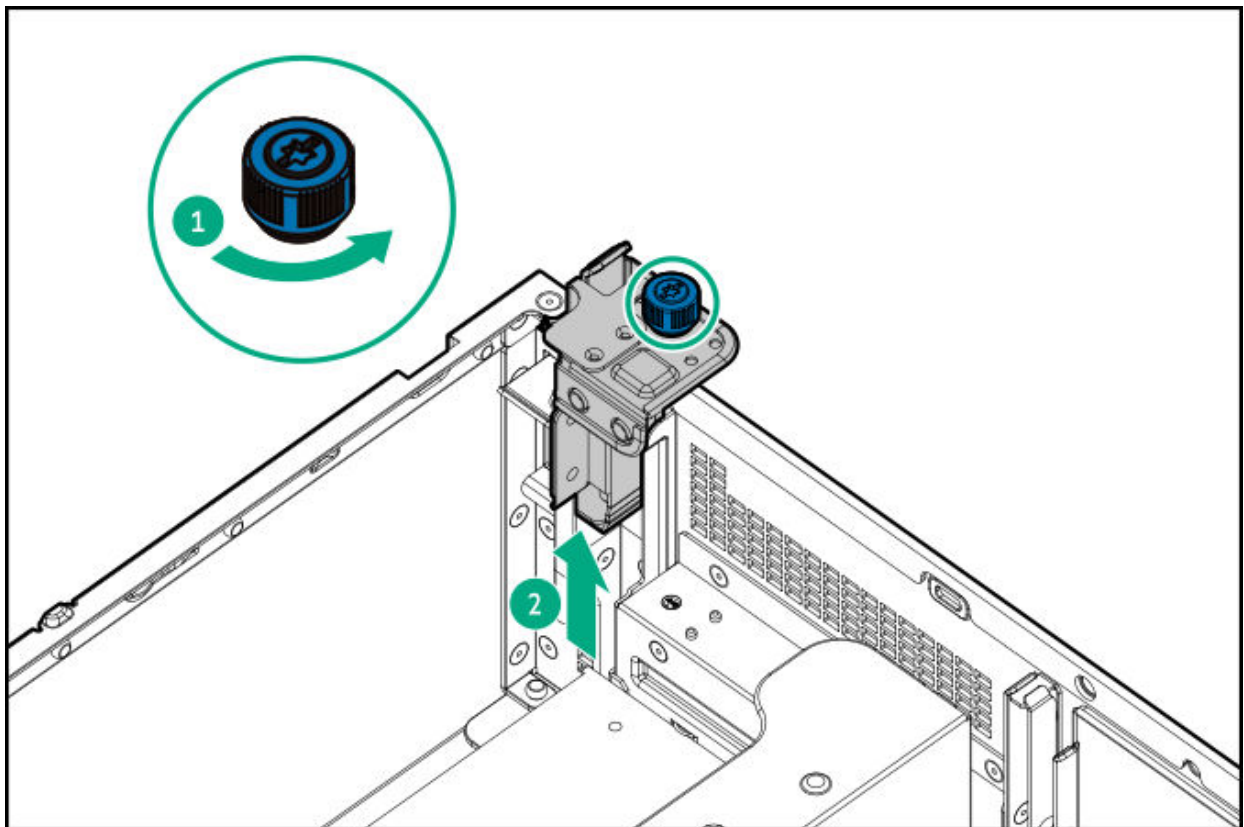

- c. Remove the expansion card from the tertiary riser.

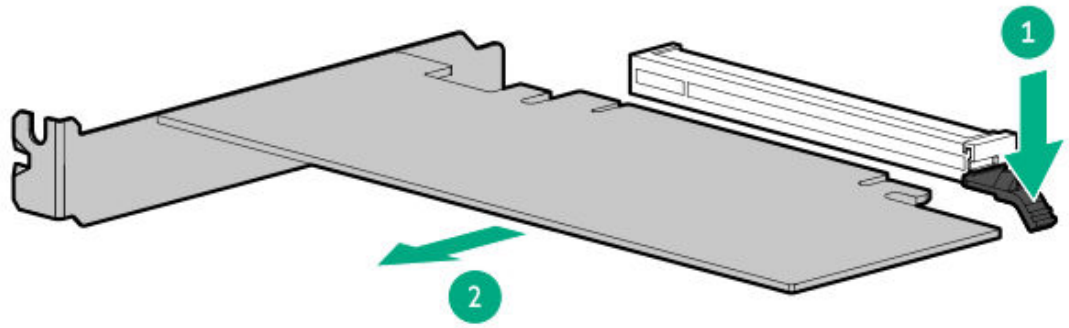

9. If installed, remove the tertiary riser.

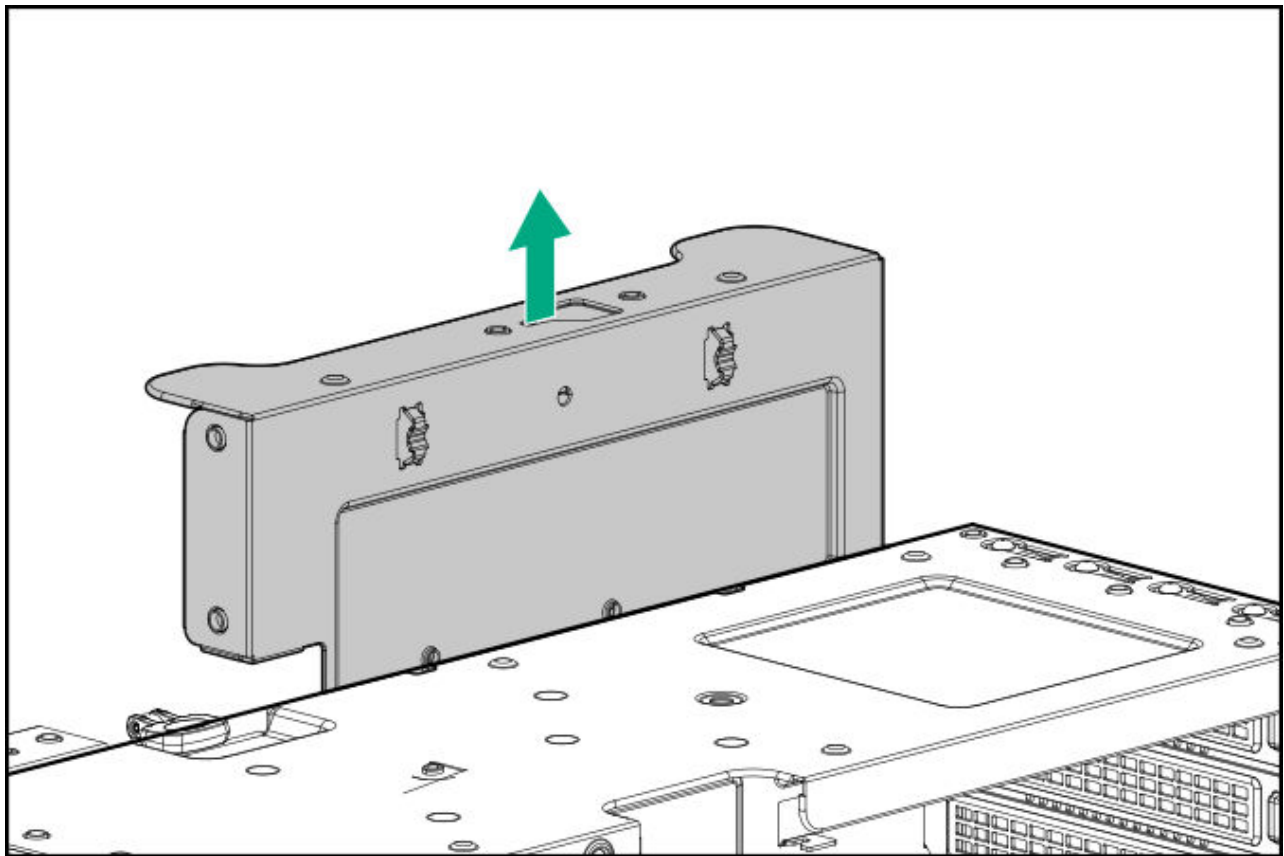

- 10. Remove the secondary riser cage:
 - a. Release the half-turn spring latch.
 - b. Lift the riser cage off the system board.

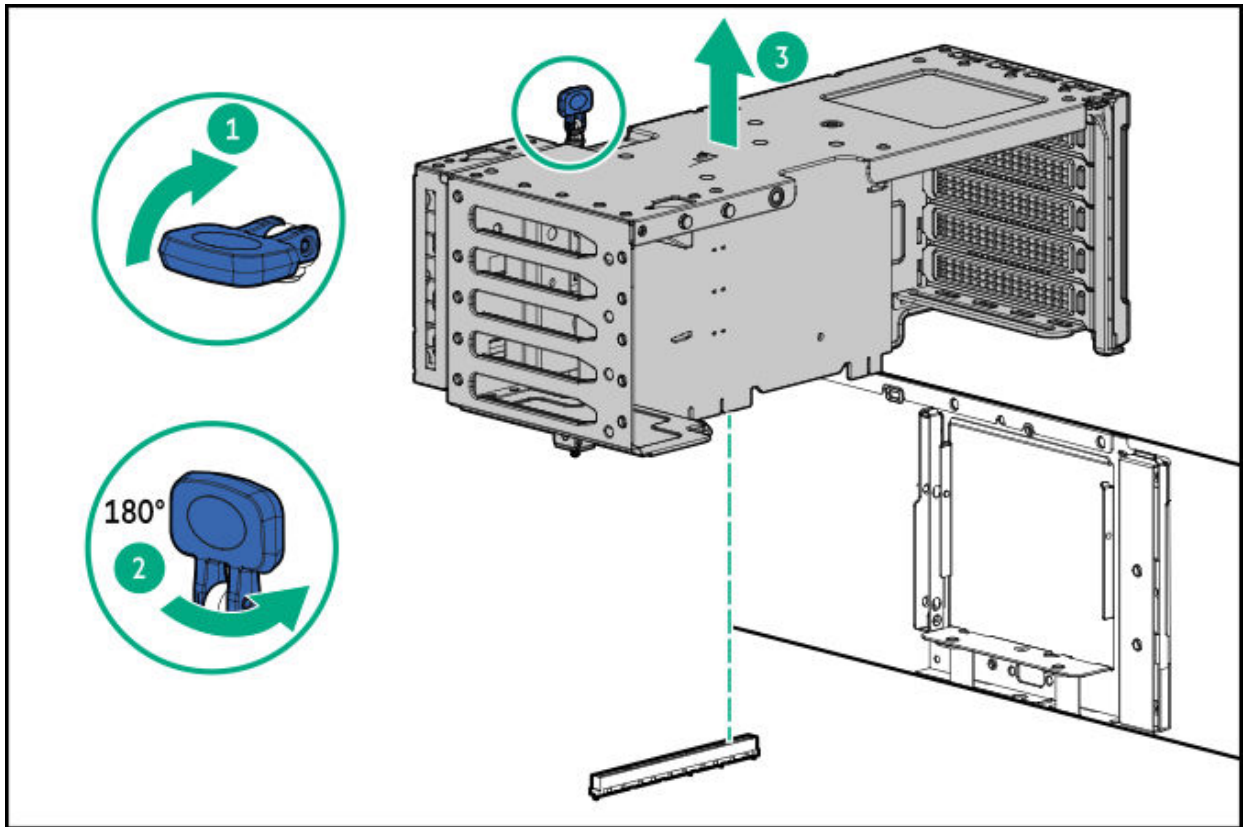

Remove the energy pack and the energy pack holder

About this task



CAUTION

A discharge of static electricity from a finger or other conductor might damage system boards or other static-sensitive devices. To prevent damage, observe [antistatic precautions](#).

Procedure

1. [Power down the server](#).
2. Remove all power:
 - a. Disconnect each power cord from the power source.
 - b. Disconnect each power cord from the server.
3. Disconnect all peripheral cables from the server.

4. Do one of the following:
 - If the server is in tower mode, place the server on a flat, level surface with the access panel facing up.
 - If the server is in rack mode, remove the server from the rack.
5. Unlock the front bezel.
6. Remove the access panel.
7. If installed, remove the boot device.
8. Remove the energy pack:
 - a. Disconnect the energy pack extension cable from the system board.
 - b. Press and hold the release latch.
 - c. Lift one end of the energy pack and release it from the holder.

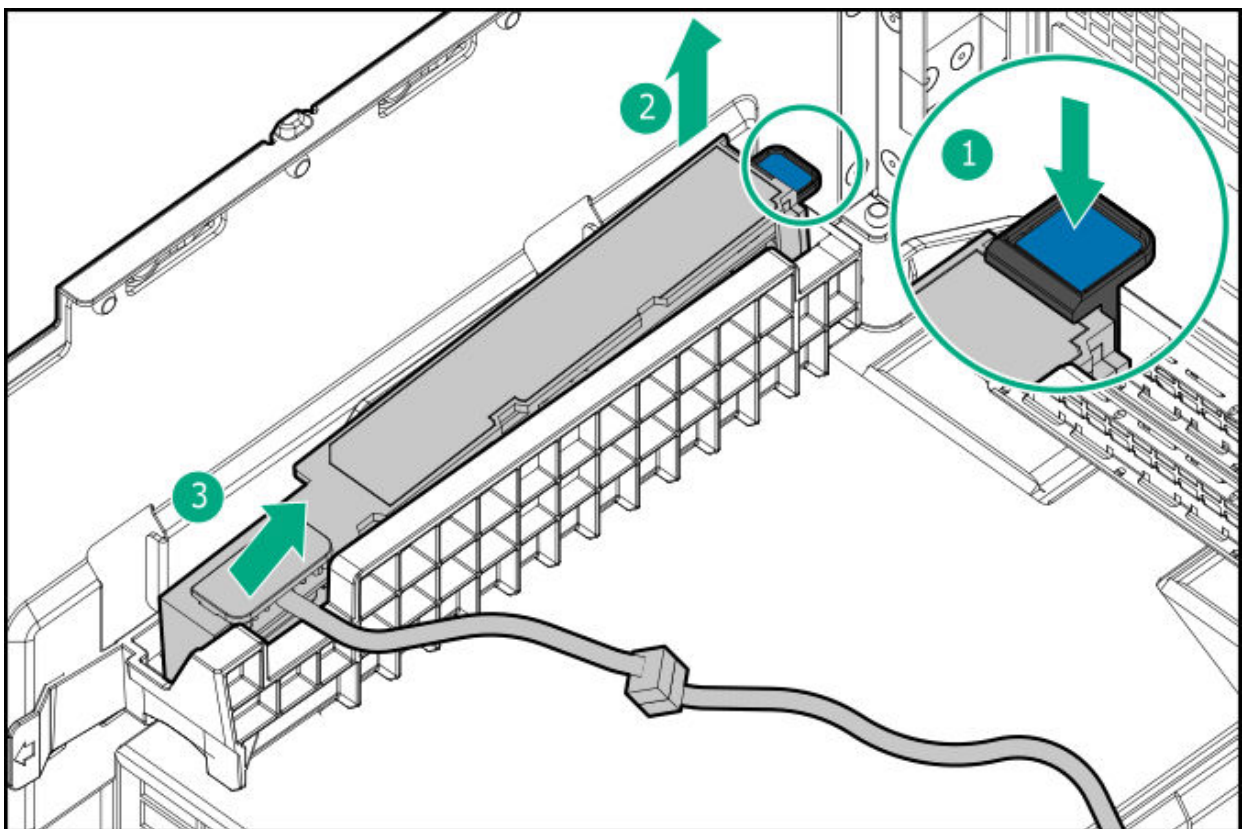

9. Remove the energy pack holder:
 - a. Press and hold the release latch on the holder.
 - b. Pull the holder towards the front panel to disengage from the chassis.

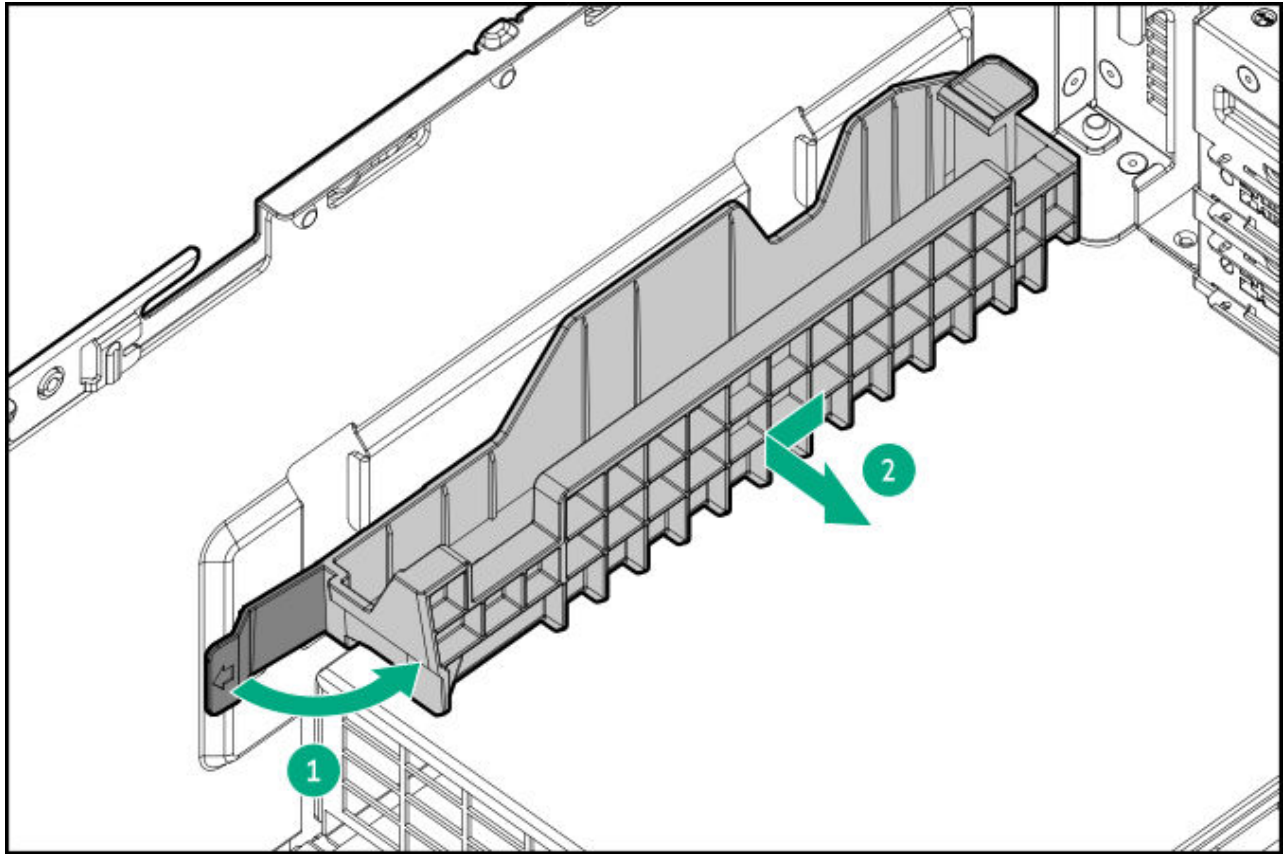

Remove the fan cage bracket

Procedure

1. Power down the server.
2. Remove all power:
 - a. Disconnect each power cord from the power source.
 - b. Disconnect each power cord from the server.
3. Disconnect all peripheral cables from the server.
4. If the server is in tower mode, place the server on a flat, level surface with the access panel facing up.
5. If the server is in rack mode, do one of the following:
 - Extend the server from the rack.
 - Remove the server from the rack.

6. Remove the access panel.
7. Remove the fan cage.
8. Remove the fan cage bracket:
 - a. Retract and hold the spring plunger.
 - b. Slide the bracket towards the front of the chassis to release it.

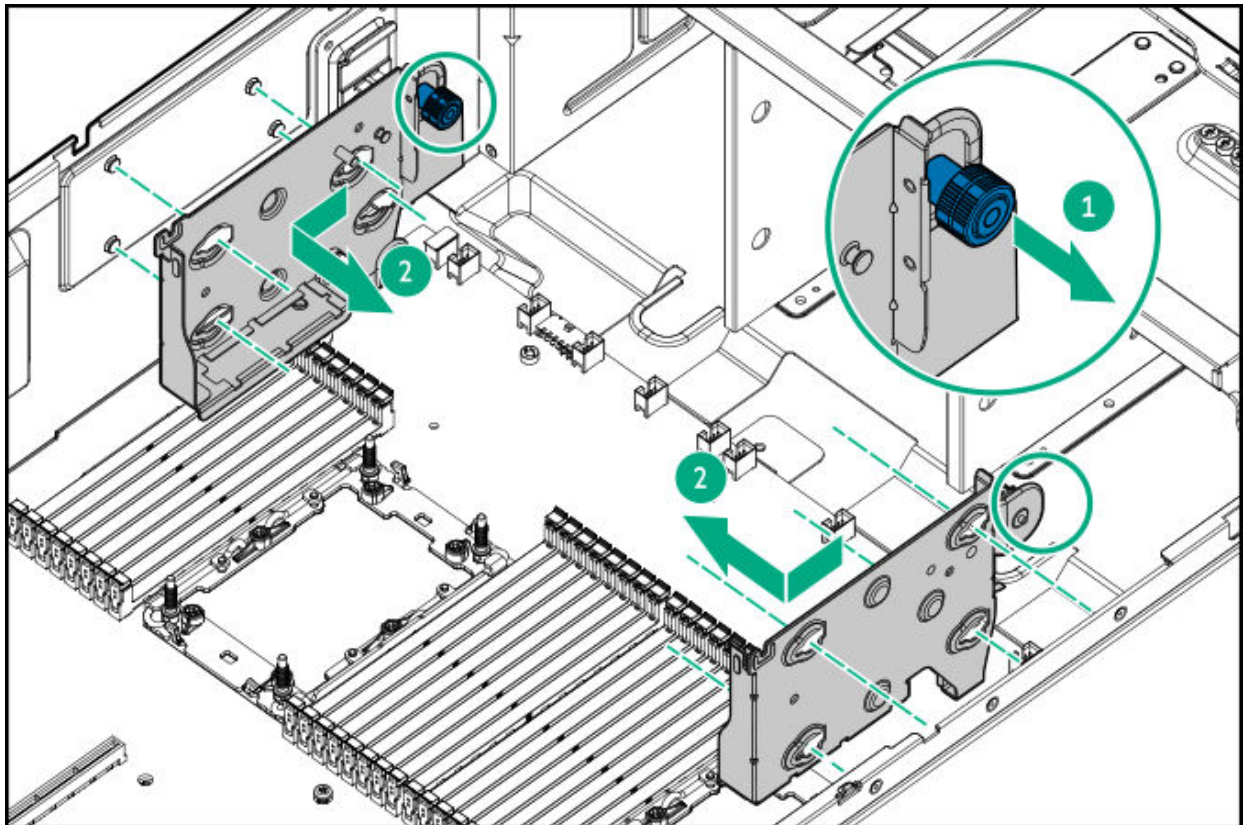

Remove the HPE NS204i-u Boot Device V2 on the power supply cage

Procedure

1. Power down the server.
2. Remove all power:
 - a. Disconnect each power cord from the power source.
 - b. Disconnect each power cord from the server.
3. Disconnect all peripheral cables from the server.

4. Do one of the following:
 - If the server is in tower mode, place the server on a flat, level surface with the access panel facing up.
 - If the server is in rack mode, remove the server from the rack.
5. Unlock the front bezel.
6. Remove the access panel.
7. Remove the boot device from the top of the power supply cage:
 - a. Pull and hold the latch.
 - b. Remove the boot device from the chassis side wall.

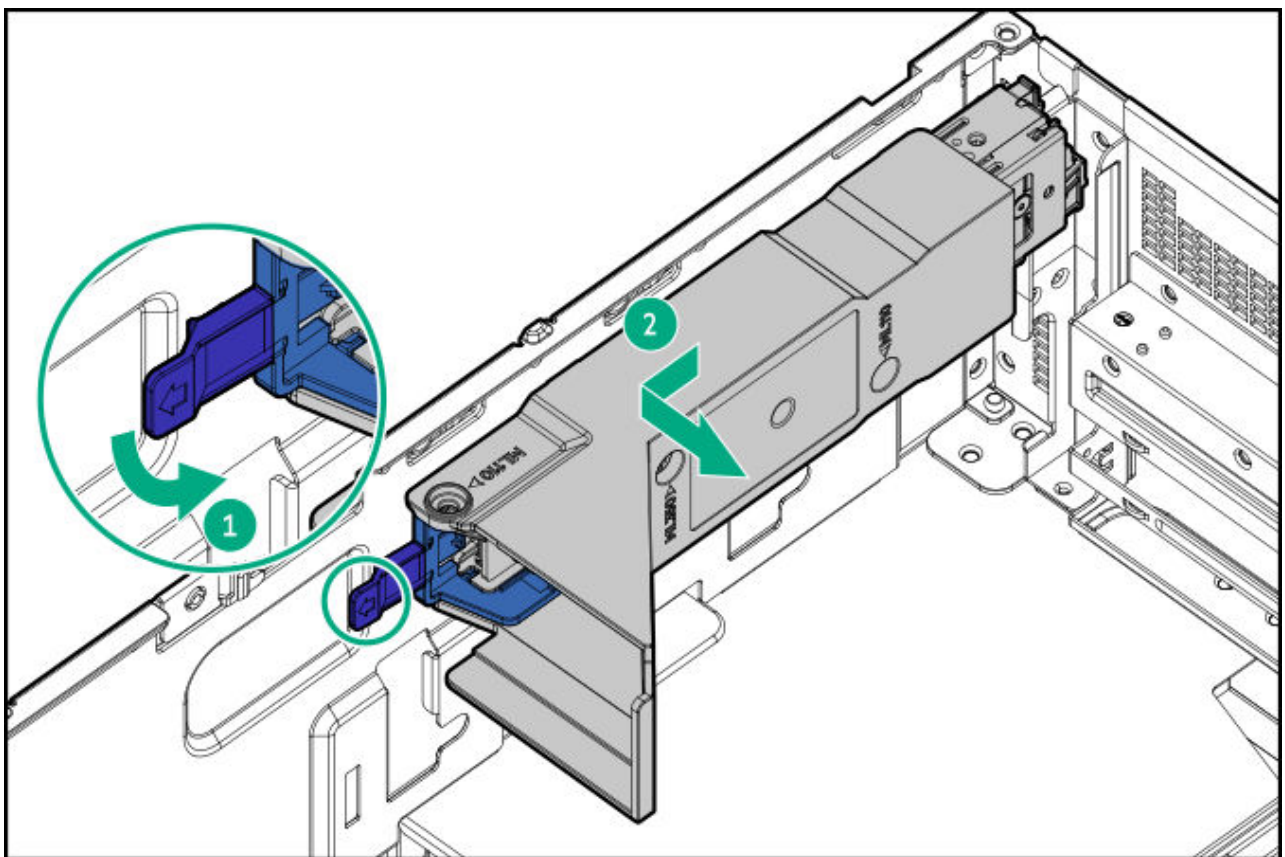

Power up the server

Procedure

- Press the Power On/Standby button.
- Use the virtual power button through iLO 7.

Removing and replacing the front bezel

About this task

https://sketchfab.com/models/2f9362031c5d401fbdefcdc7c0286455/embed?ui_infos=0&ui_watermark=0&ui_help=0&ui_vr=0&ui_settings=0&ui_inspector=0&ui_hint=2&ui_color=01a982&ui_theme=dark&autostart=1&camera=0&

Procedure

1. Unlock the front bezel.
2. Open the front bezel.

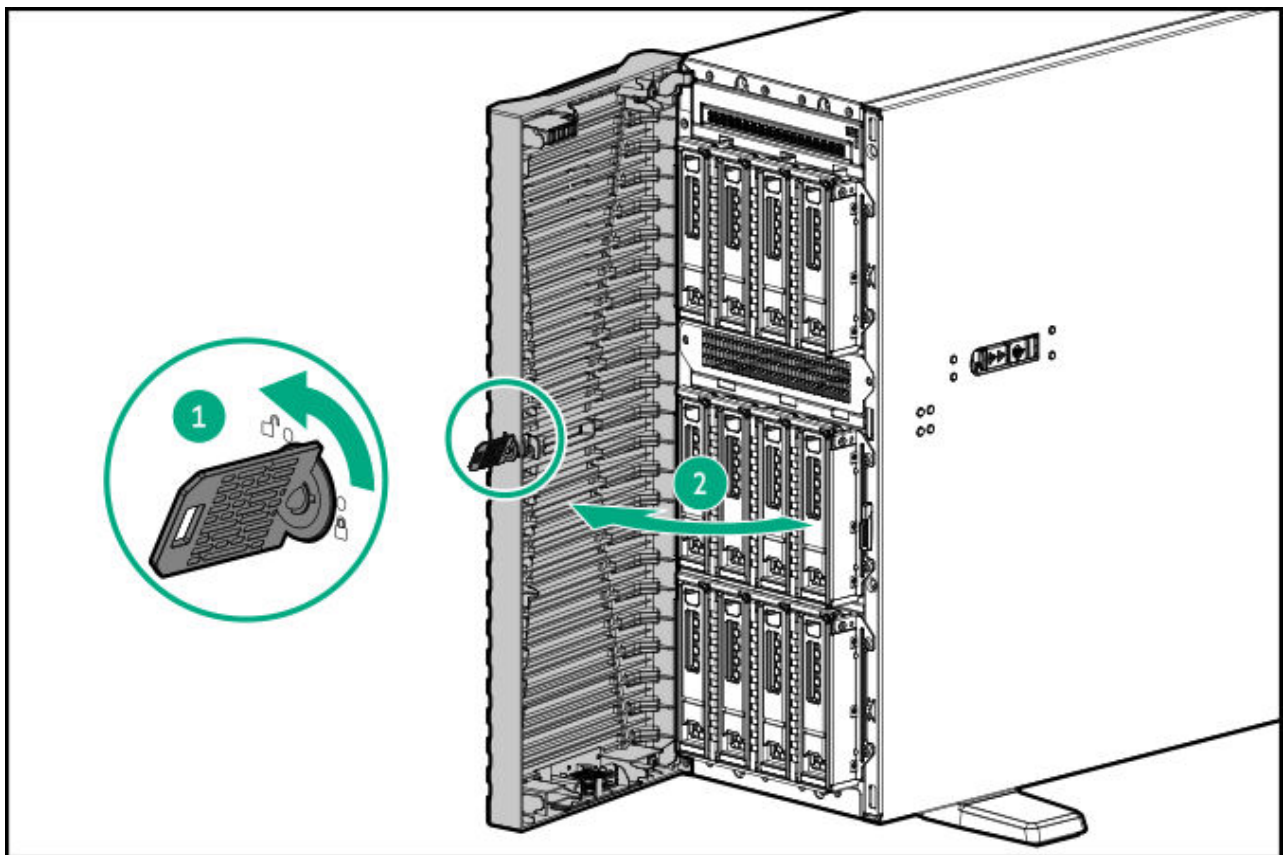

3. Release the bezel hooks from the front panel.

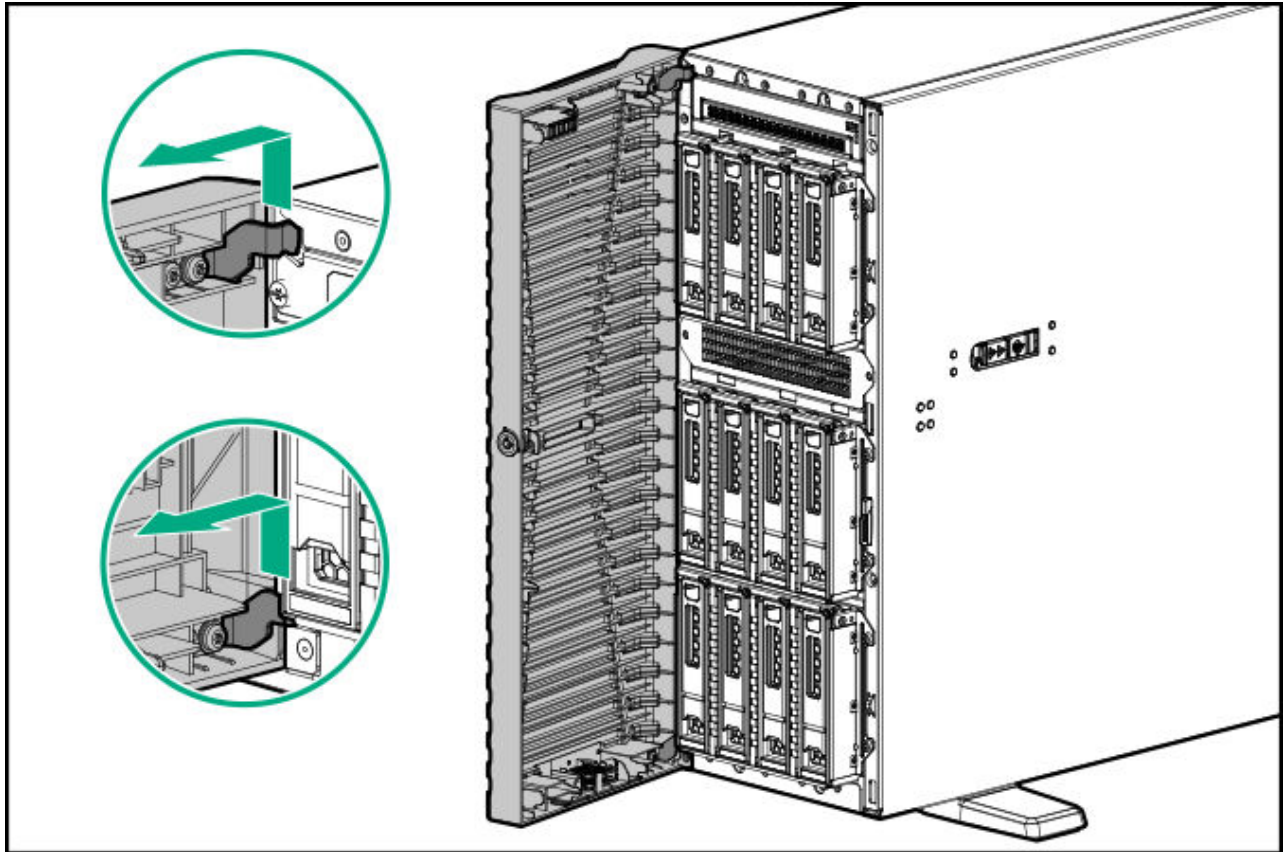

Results

The removal procedure is complete. To replace the component, reverse this procedure.

Removing and replacing a hot-plug LFF / SFF / E3.S drive

About this task

- SFF drive

https://sketchfab.com/models/1458622c15fa44c7bb9e74e10c02994d/embed?ui_infos=0&ui_watermark=0&ui_help=0&ui_vr=0&ui_settings=0&ui_inspector=0&ui_hint=2&ui_color=01a982&ui_theme=dark&autostart=1&camera=0&

- E3.S drive

https://sketchfab.com/models/ad1a6368534a4773a4891013bd6838aa/embed?ui_infos=0&ui_watermark=0&ui_help=0&ui_vr=0&ui_settings=0&ui_inspector=0&ui_hint=2&ui_color=01a982&ui_theme=dark&autostart=1&camera=0&

**CAUTION**

To prevent improper cooling and thermal damage, do not operate the server unless all bays are populated with either a component or a blank.

**CAUTION**

A discharge of static electricity from a finger or other conductor might damage system boards or other static-sensitive devices. To prevent damage, observe antistatic precautions.

Procedure

1. Back up all server data.
2. Remove the front bezel.
3. Observe the drive LED status and determine if the drive can be removed.
 - LFF / SFF drive
 - E3.S drive
4. Remove the drive.
 - LFF drive

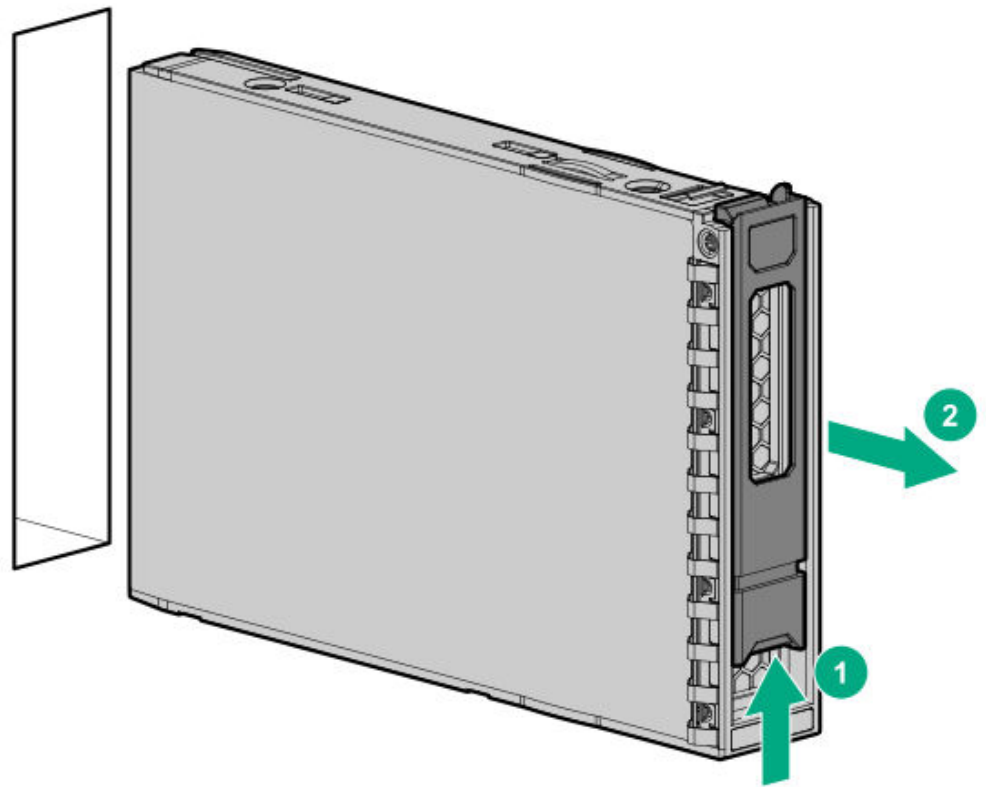

- SFF drive

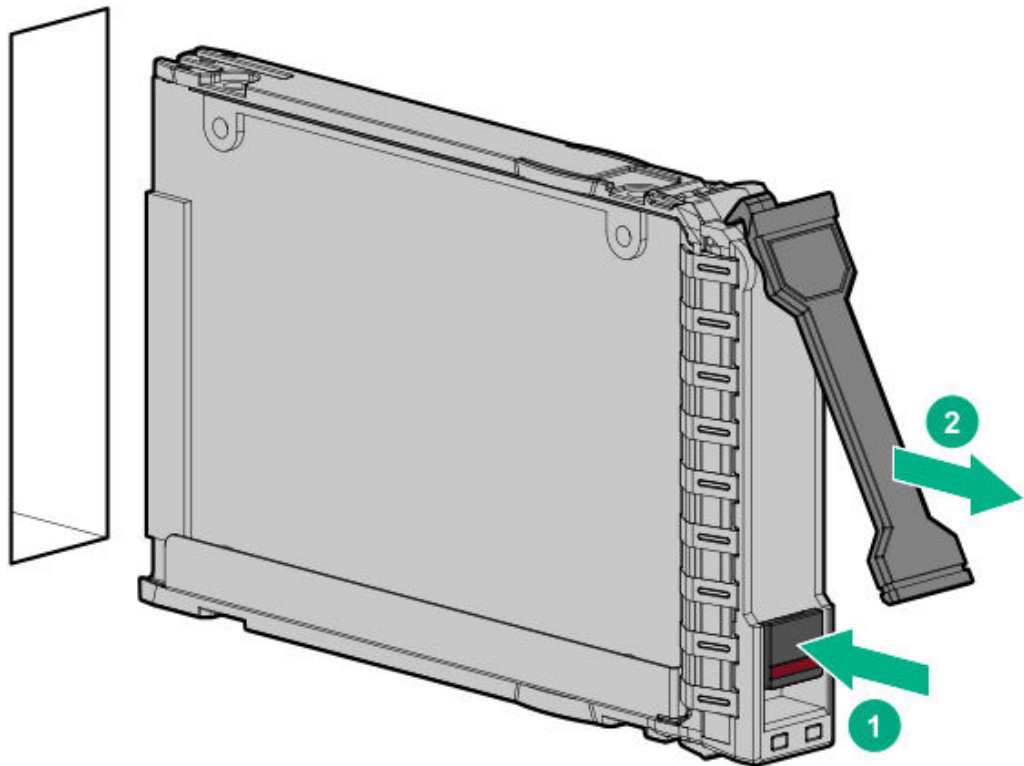

- E3.S drive

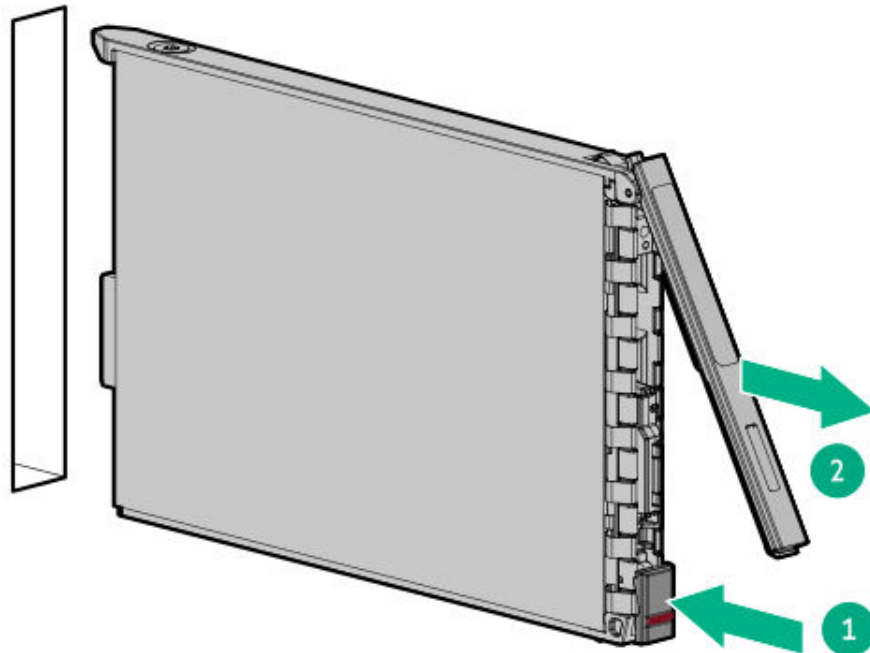

Results

The removal procedure is complete. To replace the component, reverse this procedure.

Removing and replacing the drive box blank

Prerequisites

Before you perform this procedure, make sure that you have a T-15 Torx screwdriver available.

About this task



CAUTION

To prevent improper cooling and thermal damage, do not operate the server unless all bays are populated with either a component or a blank.

Procedure

1. [Remove the front bezel.](#)
2. [Power down the server.](#)

3. Remove all power:
 - a. Disconnect each power cord from the power source.
 - b. Disconnect each power cord from the server.
4. Disconnect all peripheral cables from the server.
5. If the server is in tower mode, place the server on a flat, level surface with the access panel facing up.
6. If the server is in rack mode, do one of the following:
 - Extend the server from the rack.
 - Remove the server from the rack.
7. Remove the drive box blank:
 - a. Remove the screws.
 - b. Remove the blank.

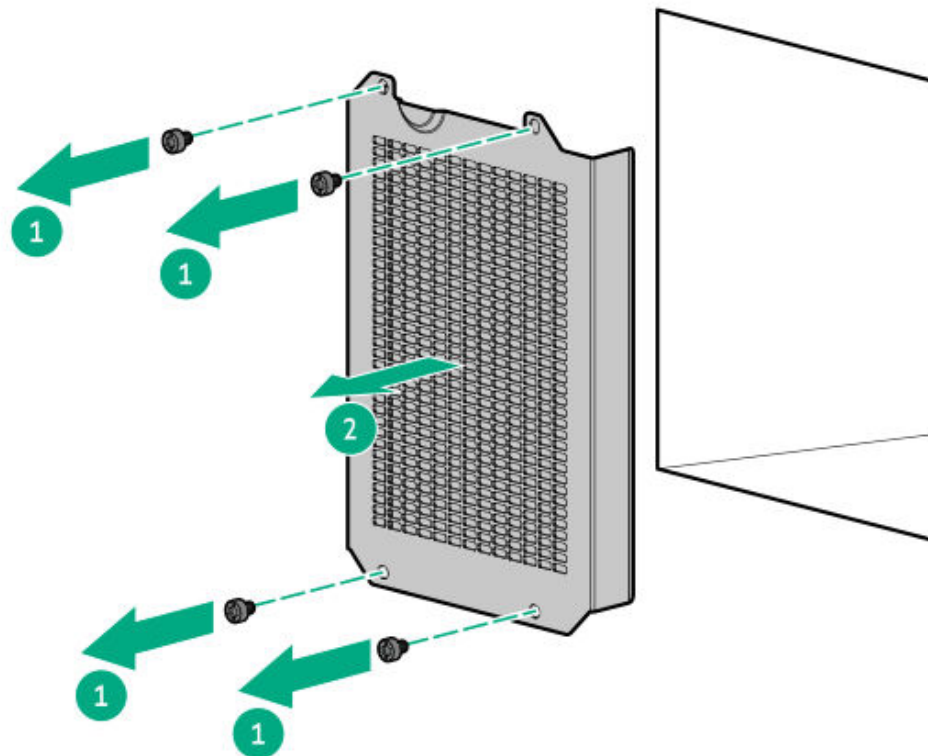

Results

The removal procedure is complete. To replace the component, reverse this procedure.

Removing and replacing a drive blank

About this task

- SFF drive blank

https://sketchfab.com/models/d949d61d04b84aa8968c6d032017825e/embed?ui_infos=0&ui_watermark=0&ui_help=0&ui_vr=0&ui_settings=0&ui_inspector=0&ui_hint=2&ui_color=01a982&ui_theme=dark&autostart=1&camera=0&

- E3.S drive blank

https://sketchfab.com/models/40a05517a5ec4778bb58e55cf12a9daf/embed?ui_infos=0&ui_watermark=0&ui_help=0&ui_vr=0&ui_settings=0&ui_inspector=0&ui_hint=2&ui_color=01a982&ui_theme=dark&autostart=1&camera=0&



CAUTION

To prevent improper cooling and thermal damage, do not operate the server unless all bays are populated with either a component or a blank.

Procedure

1. Open the front bezel.
2. Remove the drive blank.
 - LFF drive blank

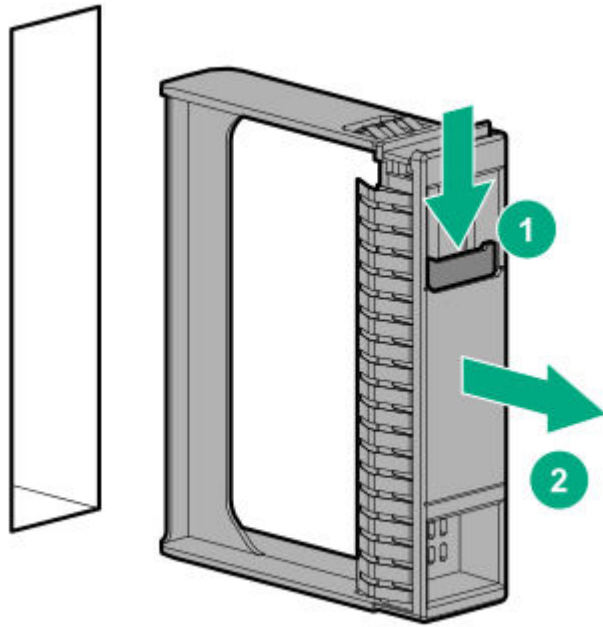

- SFF drive blank

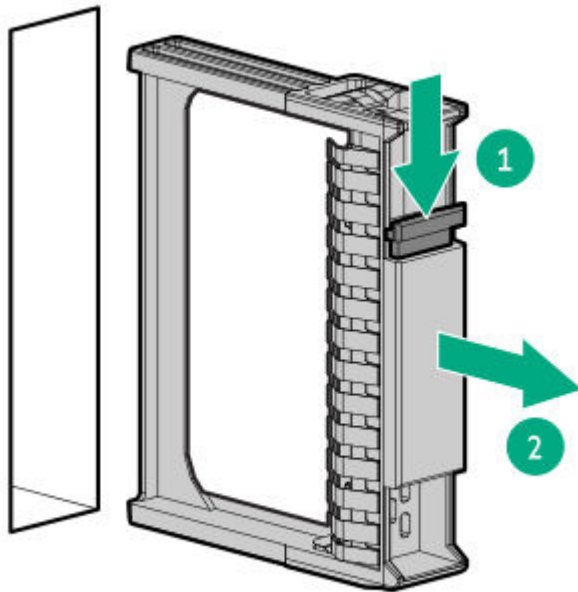

- E3.S drive blank

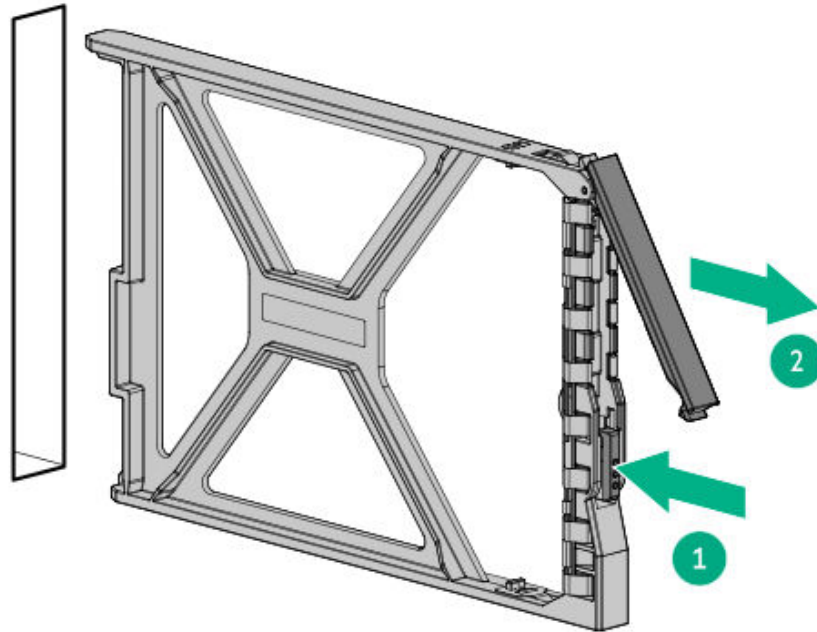

Results

The removal procedure is complete. To replace the component, reverse this procedure.

Removing and replacing the media bay filler panel

Prerequisites

Before you perform this procedure, make sure that you have a T-15 Torx screwdriver available.

About this task



CAUTION

To prevent improper cooling and thermal damage, do not operate the server unless all bays are populated with either a component or a blank.

Procedure

1. Remove the front bezel.
2. Power down the server.

3. Remove all power:
 - a. Disconnect each power cord from the power source.
 - b. Disconnect each power cord from the server.
4. Disconnect all peripheral cables from the server.
5. If the server is in tower mode, place the server on a flat, level surface with the access panel facing up.
6. If the server is in rack mode, do one of the following:
 - Extend the server from the rack.
 - Remove the server from the rack.
7. Remove the media bay filler panel:
 - a. Remove the media bay filler panel screws.
 - b. Remove the media bay filler panel.

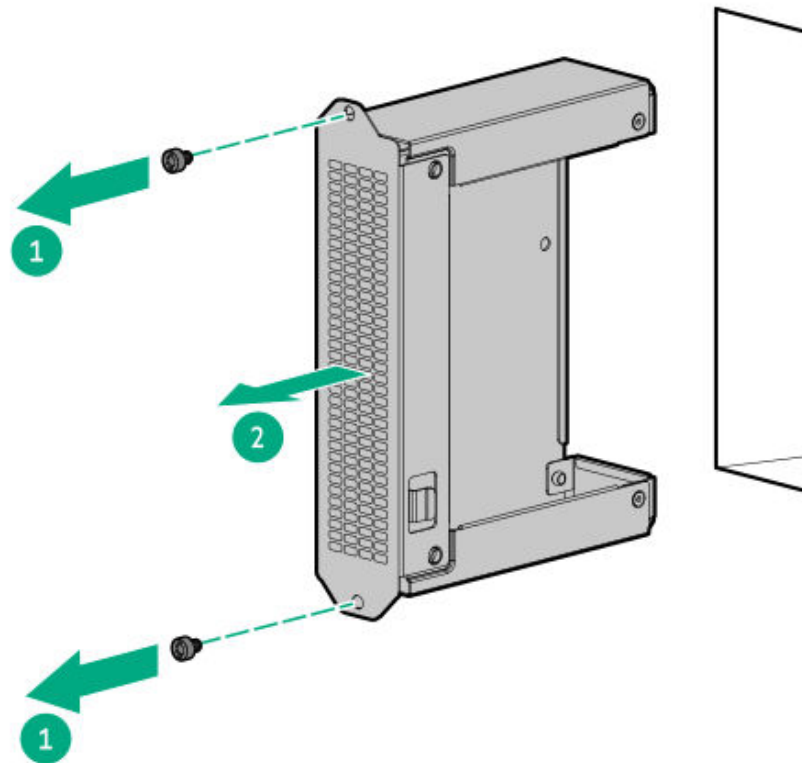

Results

The removal procedure is complete. To replace the component, reverse this procedure.

Flexible Slot power supply replacement

Depending on the configuration and the regional location where the server was purchased, the server can be configured with one of the supported [power supplies](#).

Subtopics

[Power supply warnings and cautions](#)

[DC power supply warnings and cautions](#)

[Removing and replacing a Flexible Slot power supply](#)

Power supply warnings and cautions



WARNING

To reduce the risk of electric shock or damage to the equipment:

- Do not disable the power cord grounding plug. The grounding plug is an important safety feature.
- Plug the power cord into a grounded (earthed) electrical outlet that is easily accessible at all times.
- Unplug the power cord from the power supply to disconnect power to the equipment.
- Do not route the power cord where it can be walked on or pinched by items placed against it. Pay particular attention to the plug, electrical outlet, and the point where the cord extends from the server.



WARNING

To reduce the risk of injury from electric shock hazards, do not open power supplies. Refer all maintenance, upgrades, and servicing to qualified personnel.



CAUTION

Mixing different types of power supplies in the same server might:

- Limit or disable some power supply features including support for power redundancy.
- Cause the system to become unstable and might shut down.

To ensure access to all available features, all power supplies in the same server should have the same output and efficiency ratings. Verify that all power supplies have the same part number and label color.

DC power supply warnings and cautions



WARNING

To reduce the risk of electric shock, be sure that the cable grounding kit is properly installed and connected to a suitable protective earth terminal before connecting the power source to the rack.



CAUTION

This equipment is designed to permit the connection of the earthed conductor of the DC supply circuit to the earthing conductor at the equipment. If this connection is made, all the following must be met:

- This equipment must be connected directly to the DC supply system earthing electrode conductor or to a bonding jumper from an earthing terminal bar or bus to which the DC supply system earthing electrode conductor is connected.
- This equipment must be located in the same immediate area (such as adjacent cabinets) as any other equipment that has a connection between the earthed conductor of the same DC supply circuit and the earthing conductor, and also the point of earthing of the DC system. The DC system must be earthed elsewhere.
- The DC supply source is to be located within the same premises as the equipment.
- Switching or disconnecting devices must not be in the earthed circuit conductor between the DC source and the point of connection of the earthing electrode conductor.

Removing and replacing a Flexible Slot power supply

Prerequisites

- Before replacing a power supply, review the following:
 - [Power supply warnings and cautions](#)
 - [DC power supply warnings and cautions](#)

- If you are replacing a DC power supply:
 - Make sure that you have a Phillips No.2 screwdriver available.
 - Identify the wire color and corresponding wire slots on the DC power supply:

Wire color	Description	Wire slot
Red	Positive return wire	RTN
Black	Negative input wire	-48V
Green + yellow	Ground wire	Ground

About this task

https://sketchfab.com/models/ef1927dac07d4c40b5925173aacddb9a/embed?ui_infos=0&ui_watermark=0&ui_help=0&ui_vr=0&ui_settings=0&ui_inspector=0&ui_hint=2&ui_color=01a982&ui_theme=dark&autostart=1&camera=0&



WARNING

To reduce the risk of personal injury from hot surfaces, allow the power supply, power supply blank, or dual slot power supply adapter to cool before touching it.



CAUTION

To prevent improper cooling and thermal damage, do not operate the server unless all bays are populated with either a component or a blank.

Procedure

1. Power down the server.
2. To remove an AC power supply, do the following:
 - a. Release the power cords, wires, and cables from the strain relief strap.

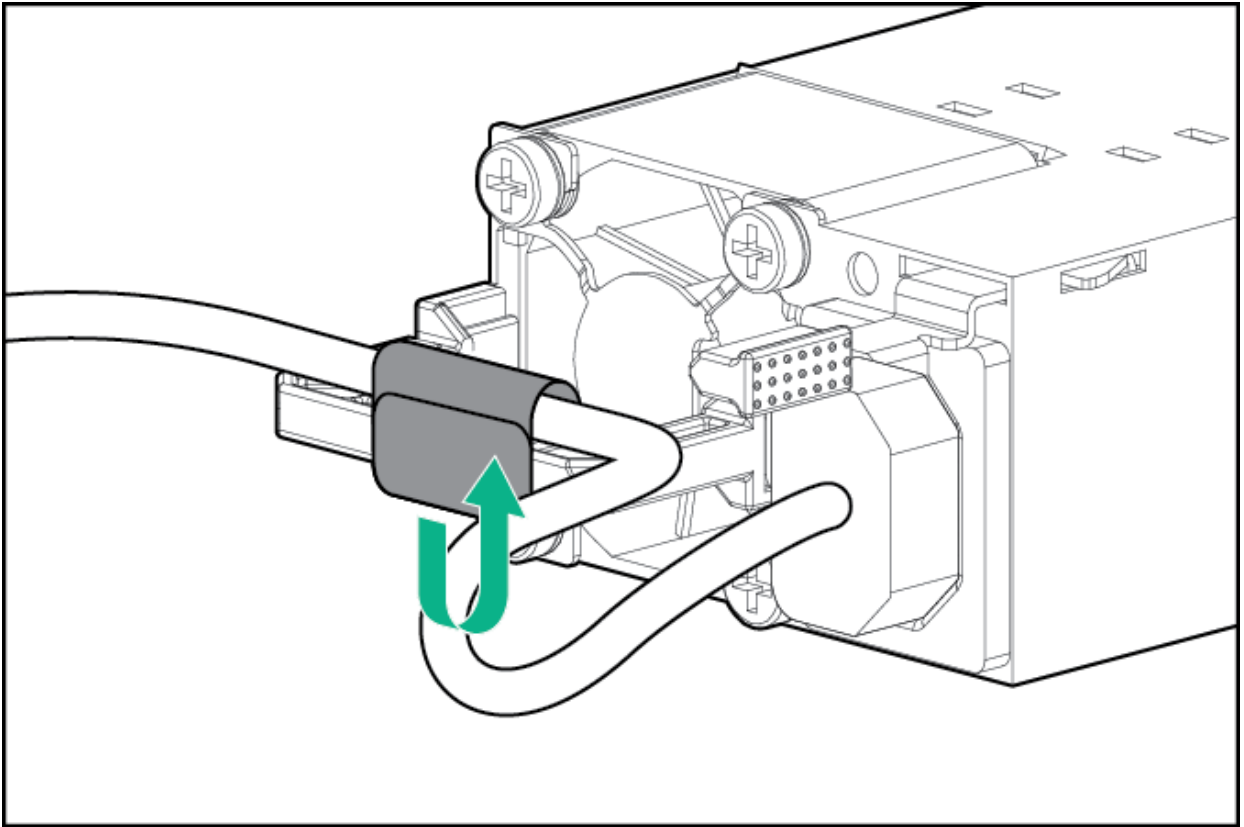

b. Disconnect the power cord from the power supply.

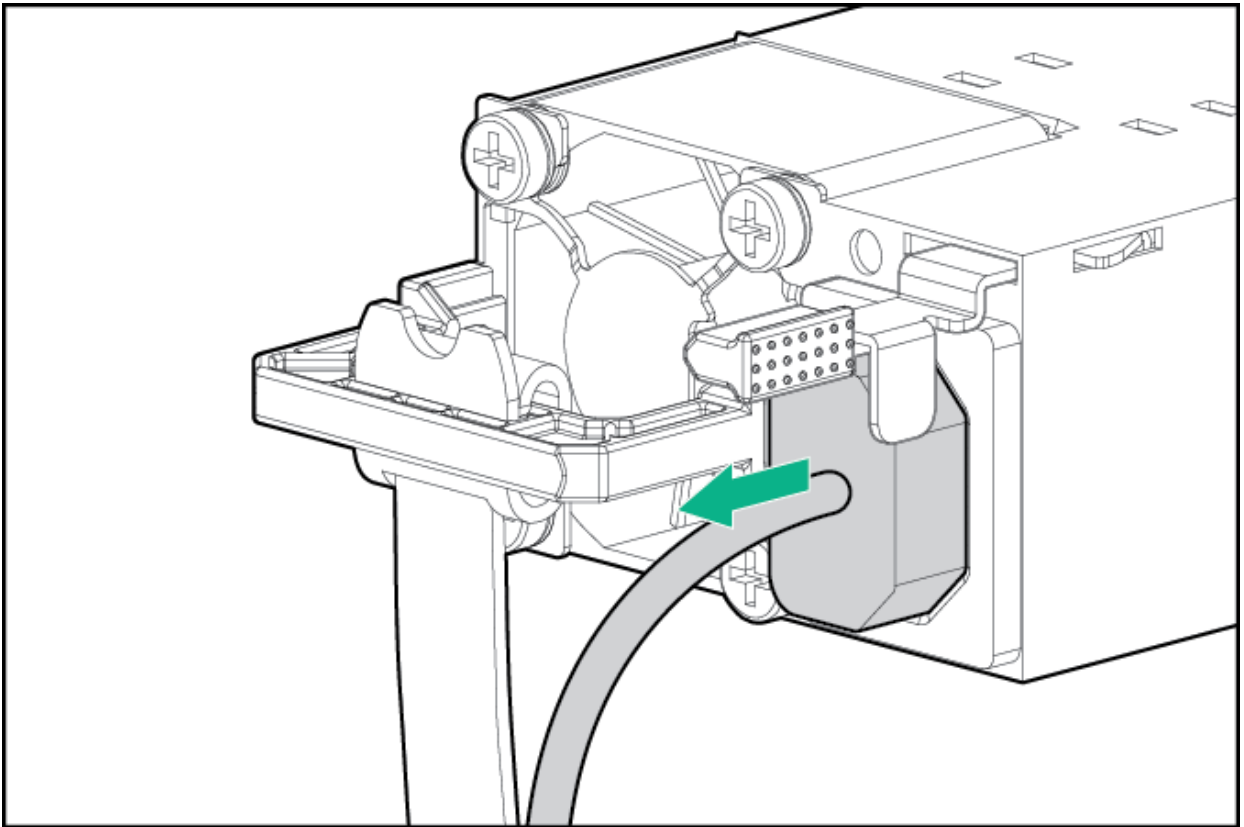

c. Remove the power supply.

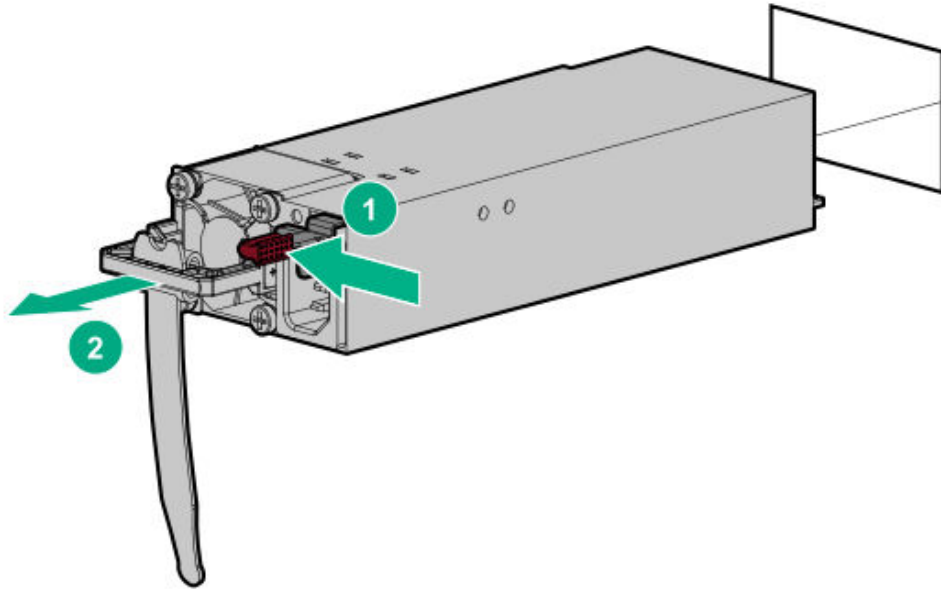

3. To remove the DC power supply, do the following:

a. Remove the power supply.

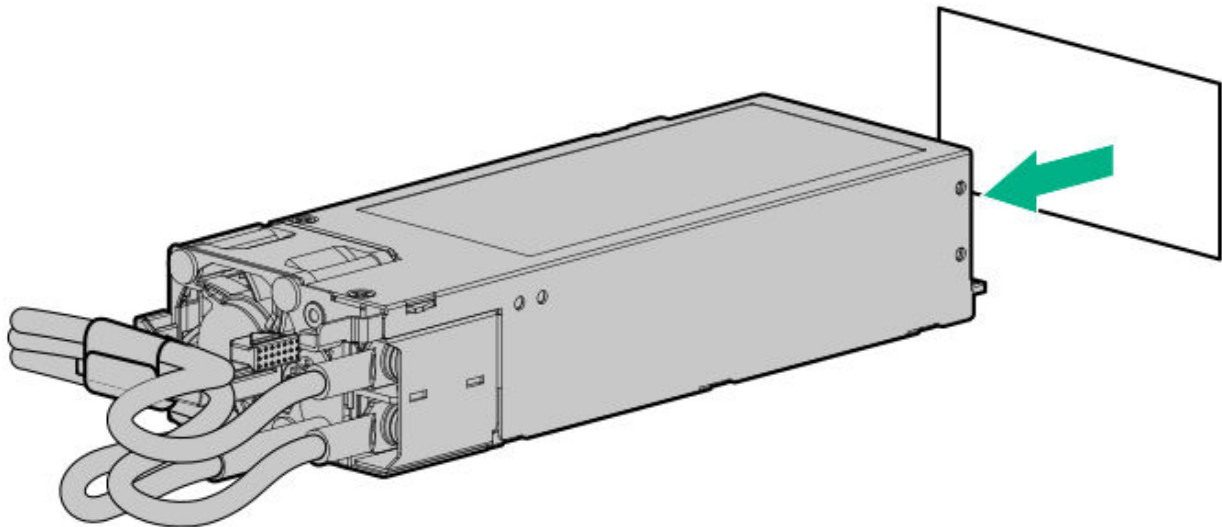

b. Release the ground, positive return, and negative input wires from the strain relief strap.

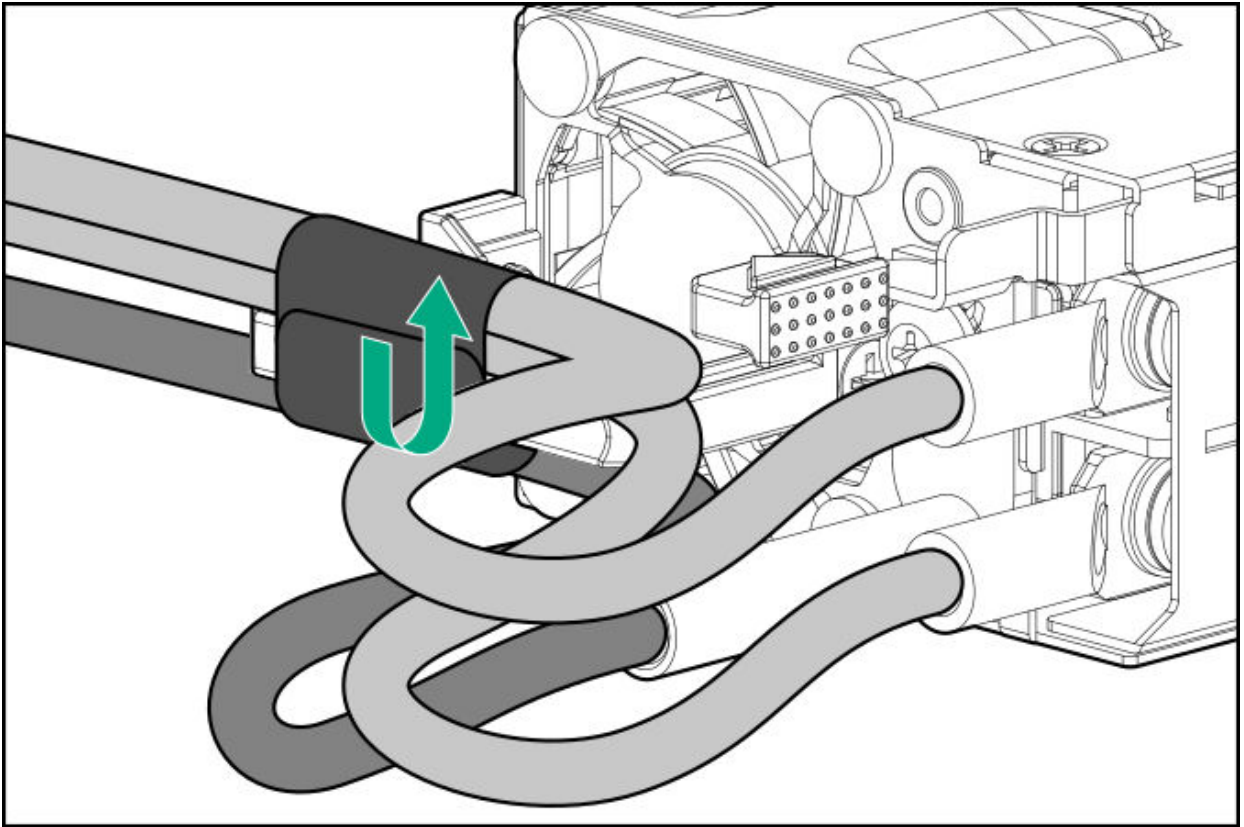

c. Remove the protective cover from the power supply.

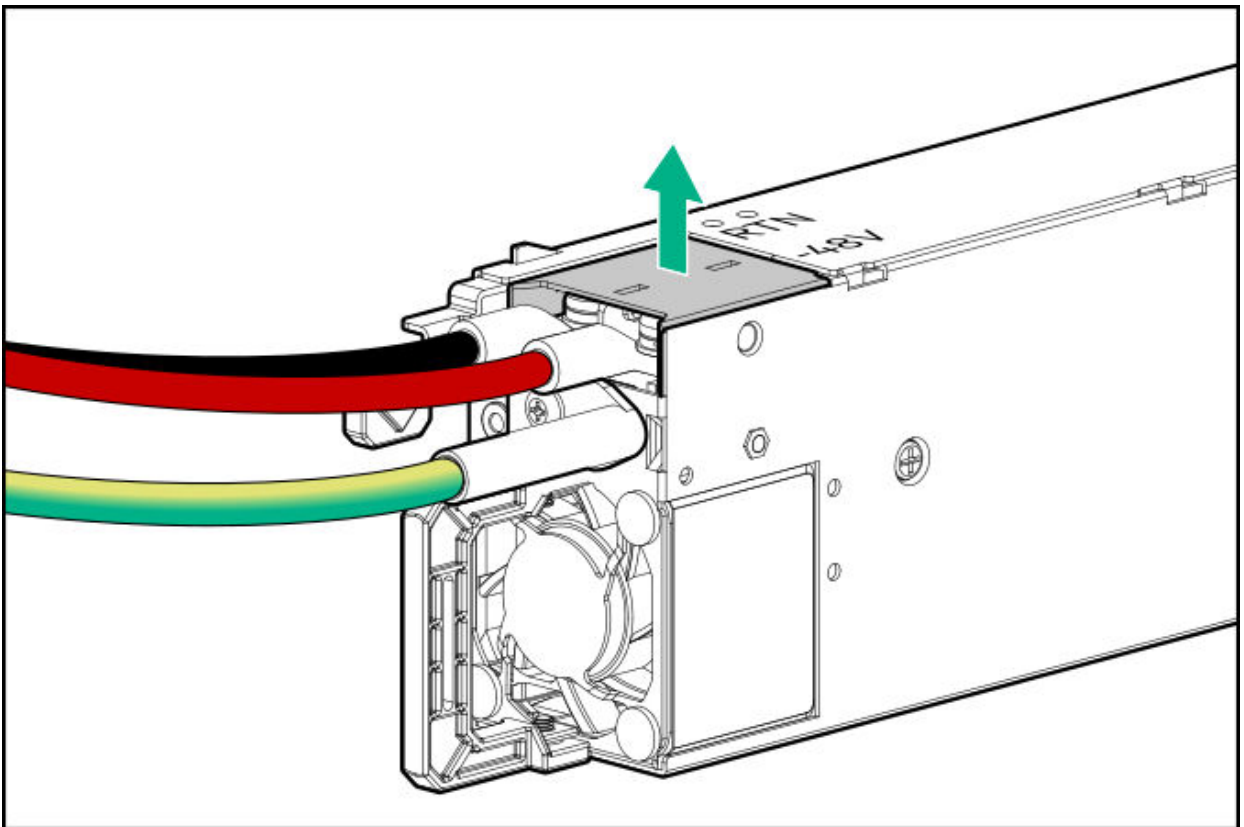

d. Remove the line wire (red) from the -48V slot on the DC power supply.

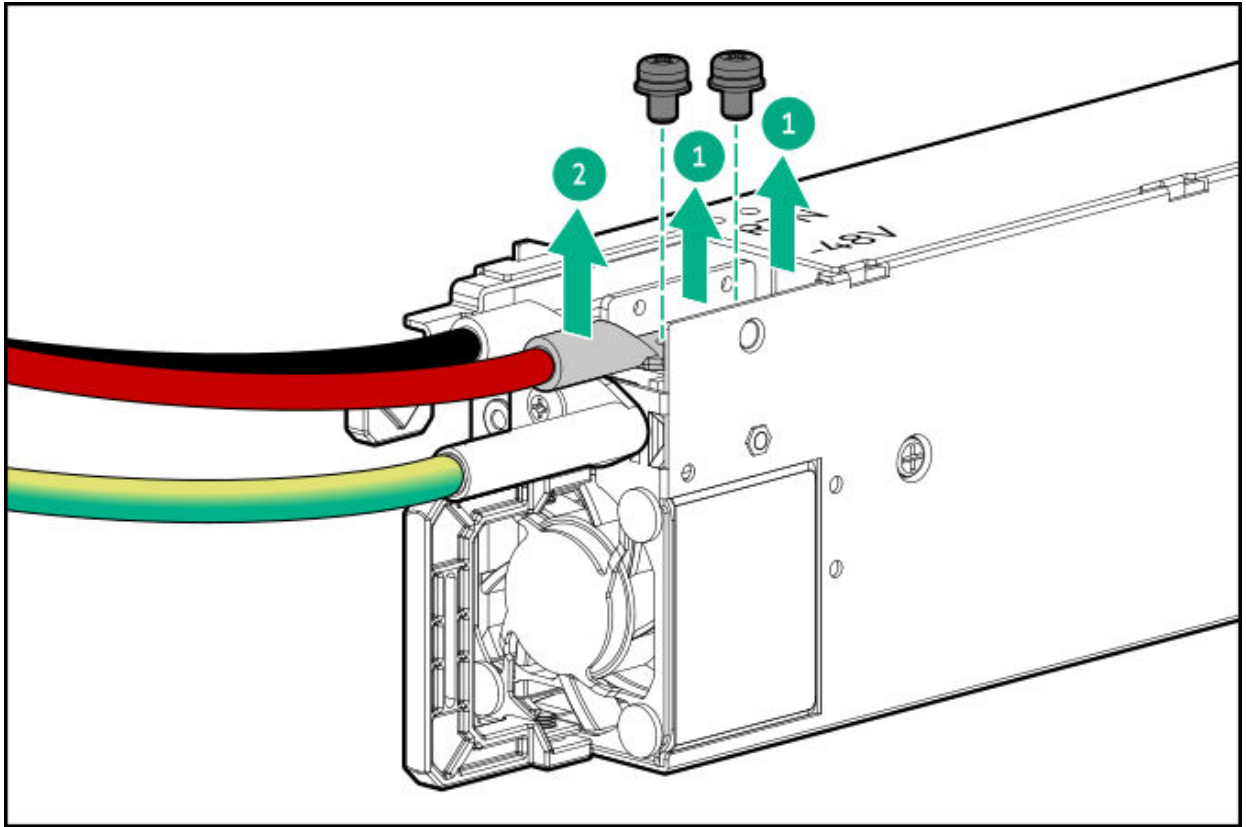

e. Remove the return wire (black) from the RTN slot on the DC power supply.

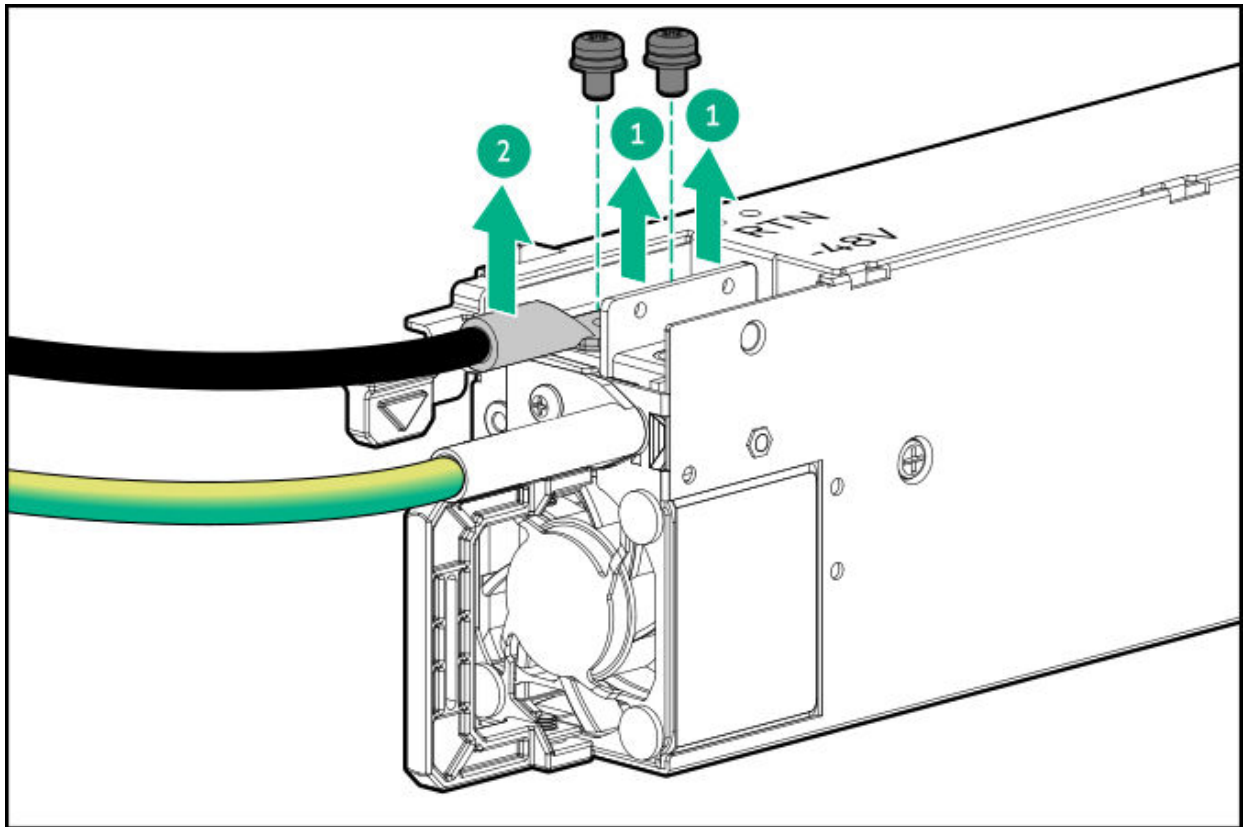

f. Remove the ground wire (green and yellow) from the DC power supply.

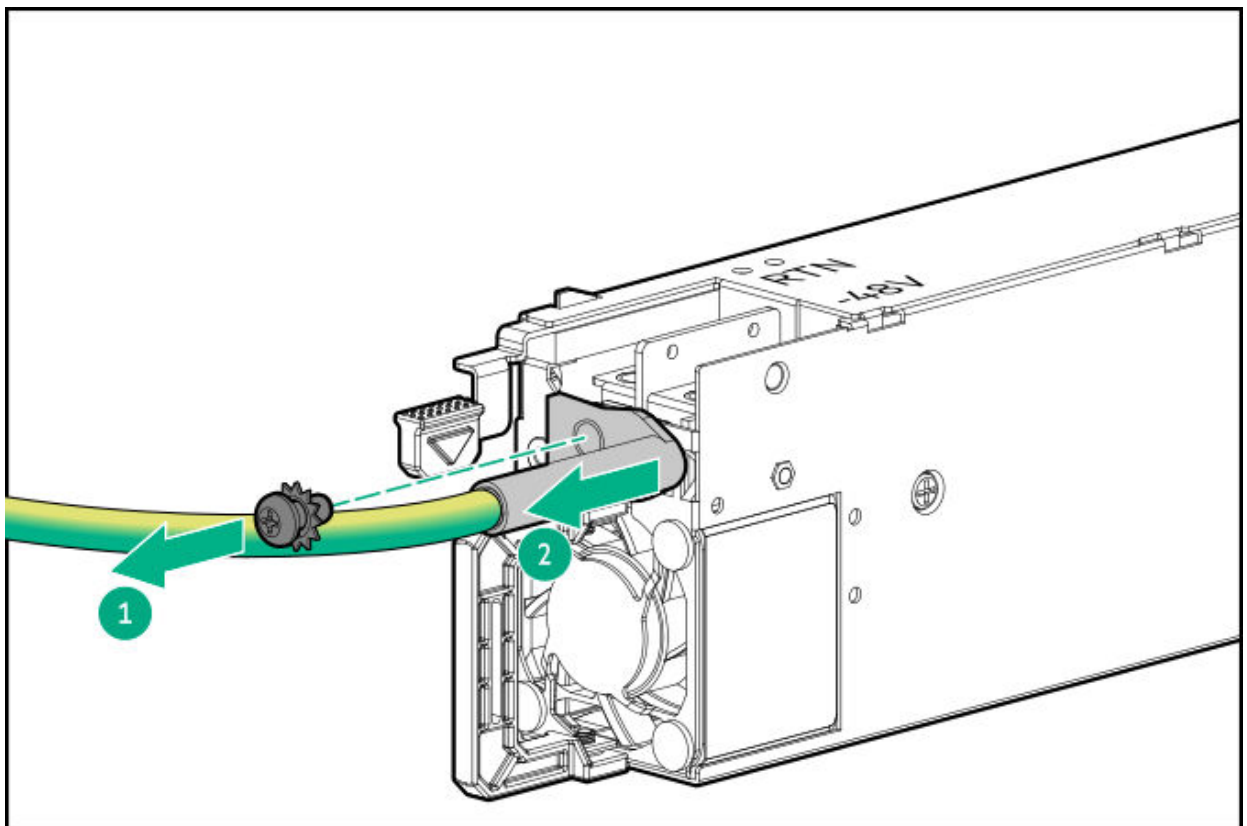

Results

The removal procedure is complete. To replace the component, reverse this procedure.

Removing and replacing a power supply blank

About this task



WARNING

To reduce the risk of personal injury from hot surfaces, allow the power supply, power supply blank, or dual slot power supply adapter to cool before touching it.



CAUTION

To prevent improper cooling and thermal damage, do not operate the server unless all bays are populated with either a component or a blank.

Procedure

Remove the power supply blank from the bay.

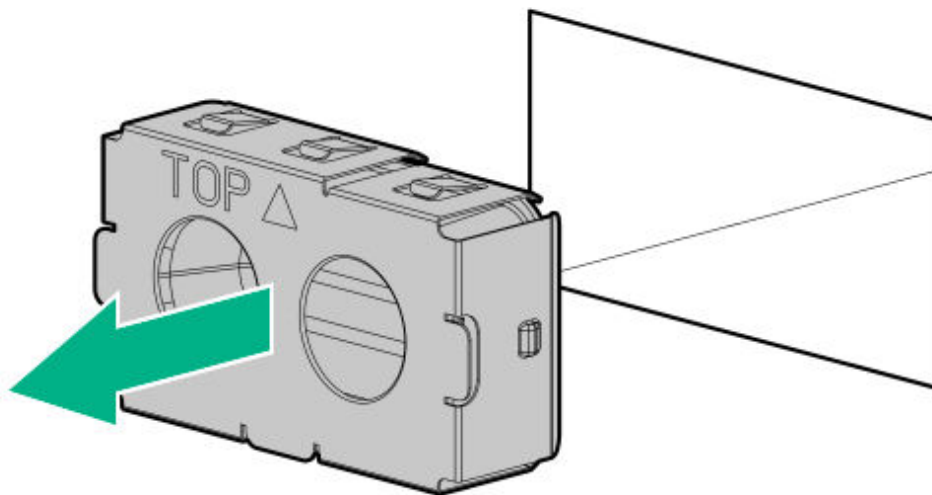

Results

The removal procedure is complete. To replace the component, reverse this procedure.

Removing and replacing the cable management arm

About this task



CAUTION

Support the CMA during the removal and replacement procedures. Do not allow the CMA to hang by its own weight during the procedure.

Procedure

1. Remove the peripheral cables and power cords from the CMA:
 - a. Open the cable clamps.
 - b. Remove the peripheral cables and power cords.

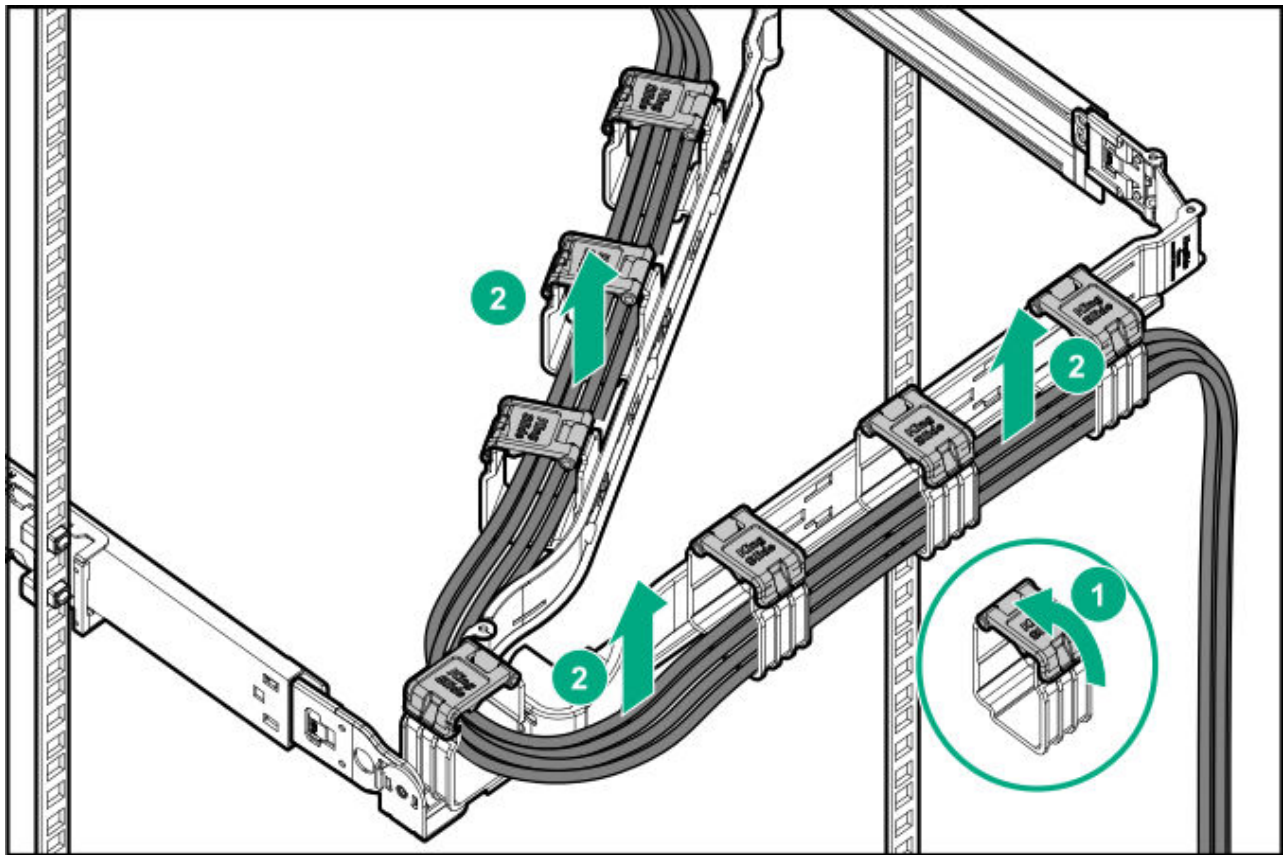

2. Remove the cable management arm:
 - a. Press and hold the blue **PUSH** button on the retention bracket.
 - b. Swing the arm away from the mounting rail.
 - c. Press and hold the blue **PUSH** buttons on the outer and inner tabs and detach from the rack rails.

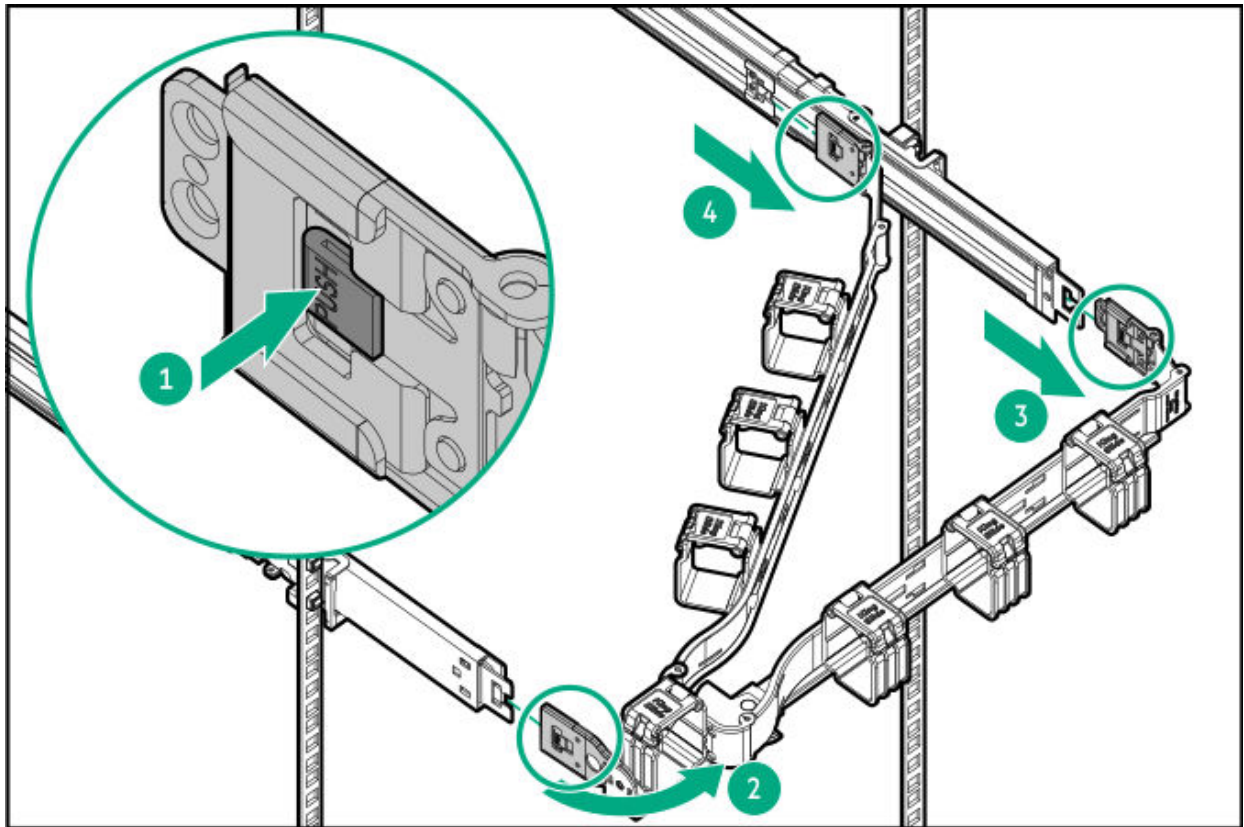

Results

The removal procedure is complete. To replace the component, reverse this procedure.

Removing and replacing the rack rails

Prerequisites

If you are replacing the rack mounting rails from a threaded-hole rack, make sure that you have a Phillips No. 2 screwdriver available.

Procedure

1. Power down the server.
2. Remove the cable management arm.
3. Remove all power:
 - a. Disconnect each power cord from the power source.
 - b. Disconnect each power cord from the server.

4. Disconnect all peripheral cables from the server.
5. Remove the server from the rack.
6. Place the server on a flat, level work surface.
7. Slide and hold the white release tab in the direction shown, and slide out the server tray from the rack.

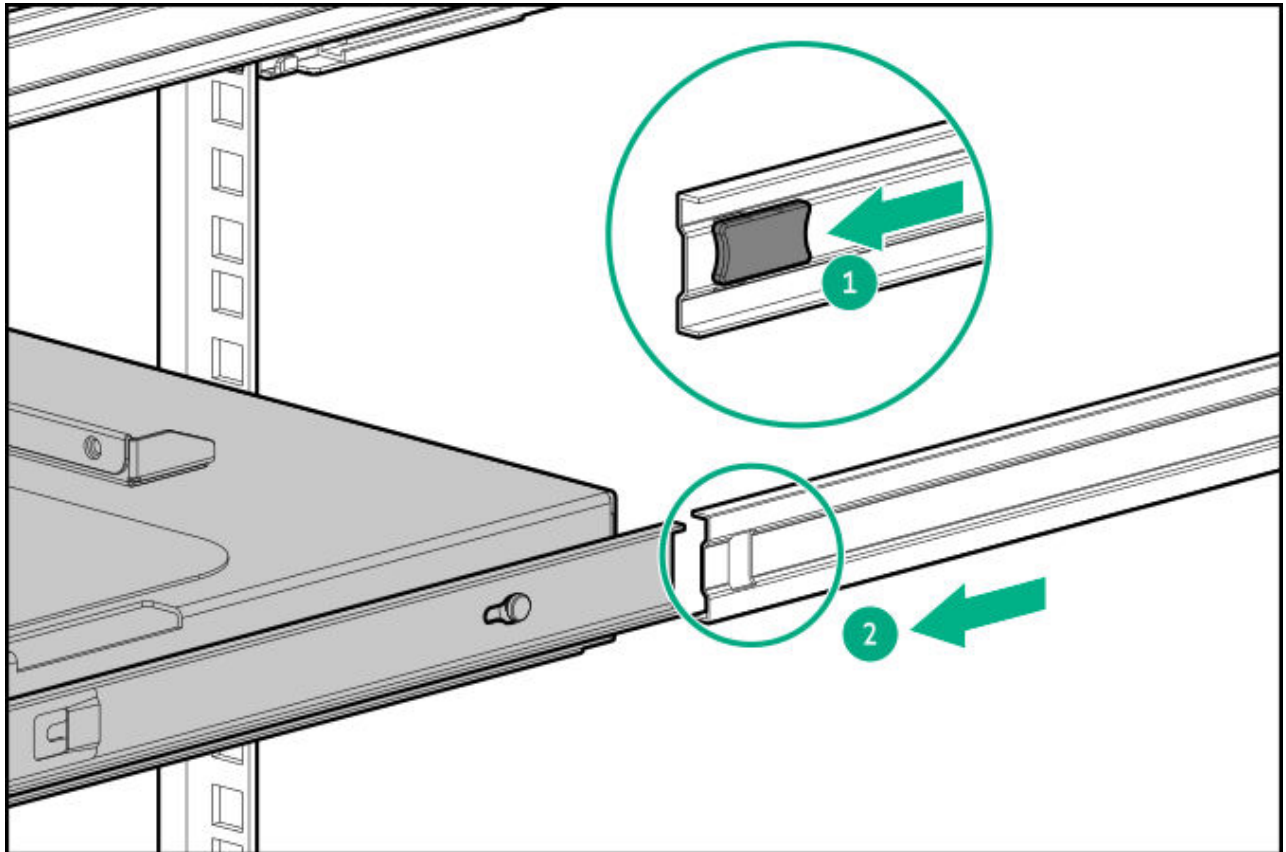

8. If you are replacing a rack mounting rail, do the following:
 - a. If installed, remove the shipping screw from the rear rack column.

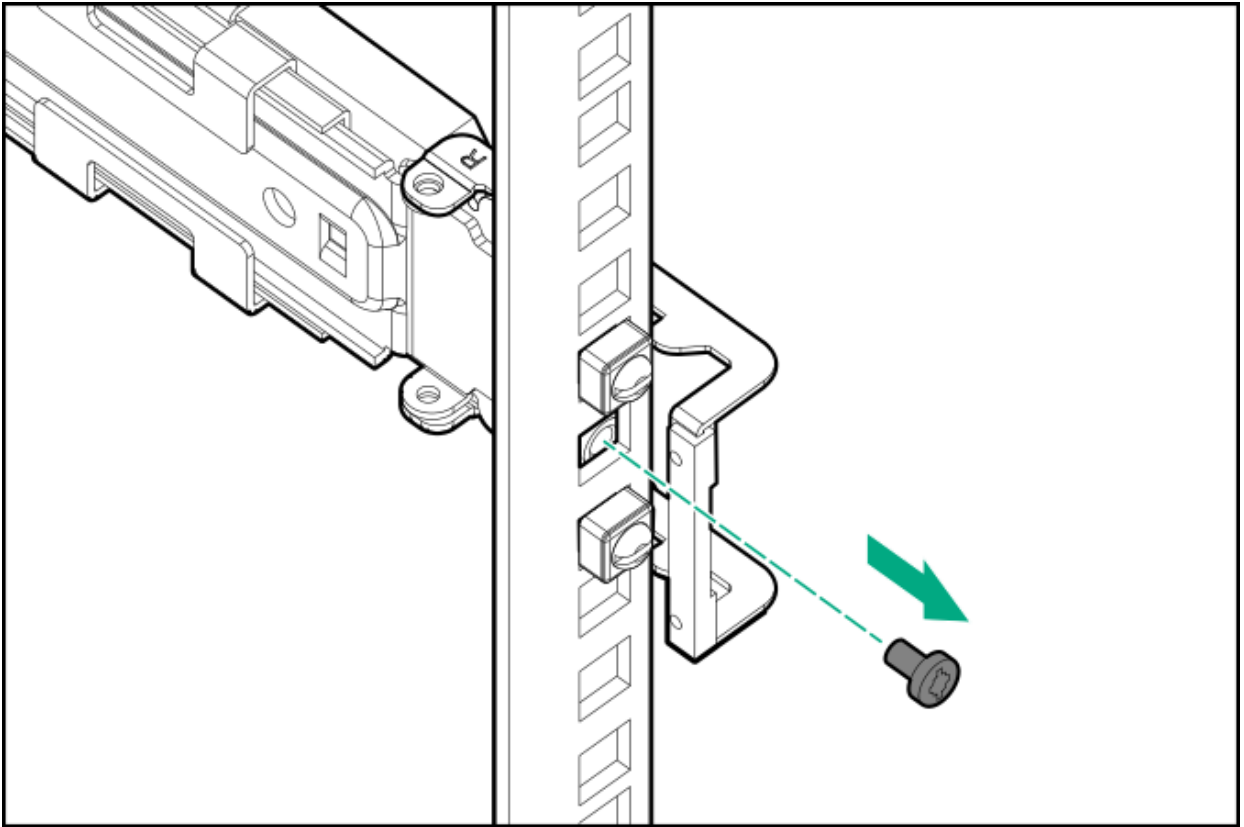

- b. Retract and hold the rear retention bracket.
- c. Slide out the rear end of the rail to disengage it from the rear rack column.

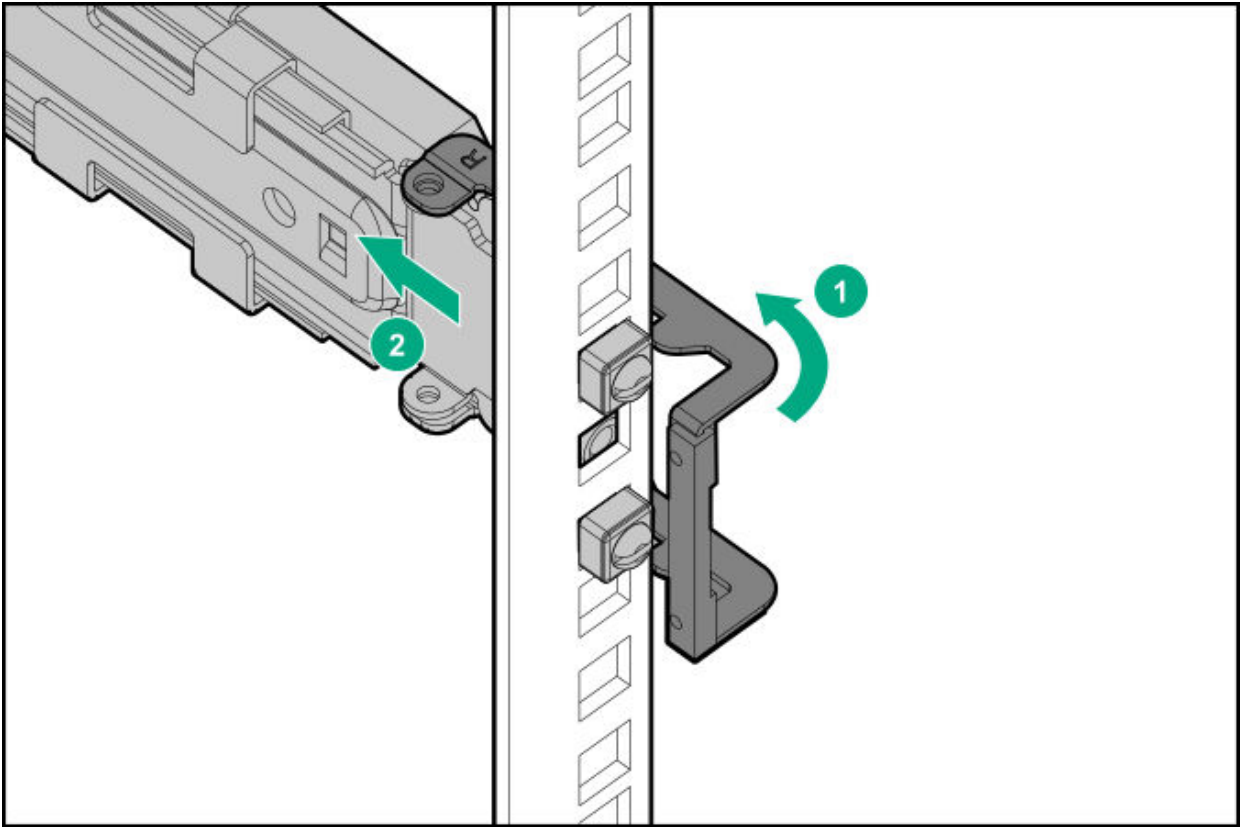

- d. Retract and hold the front retention bracket.
- e. Slide out the front end of the rail to disengage it from the front rack column.

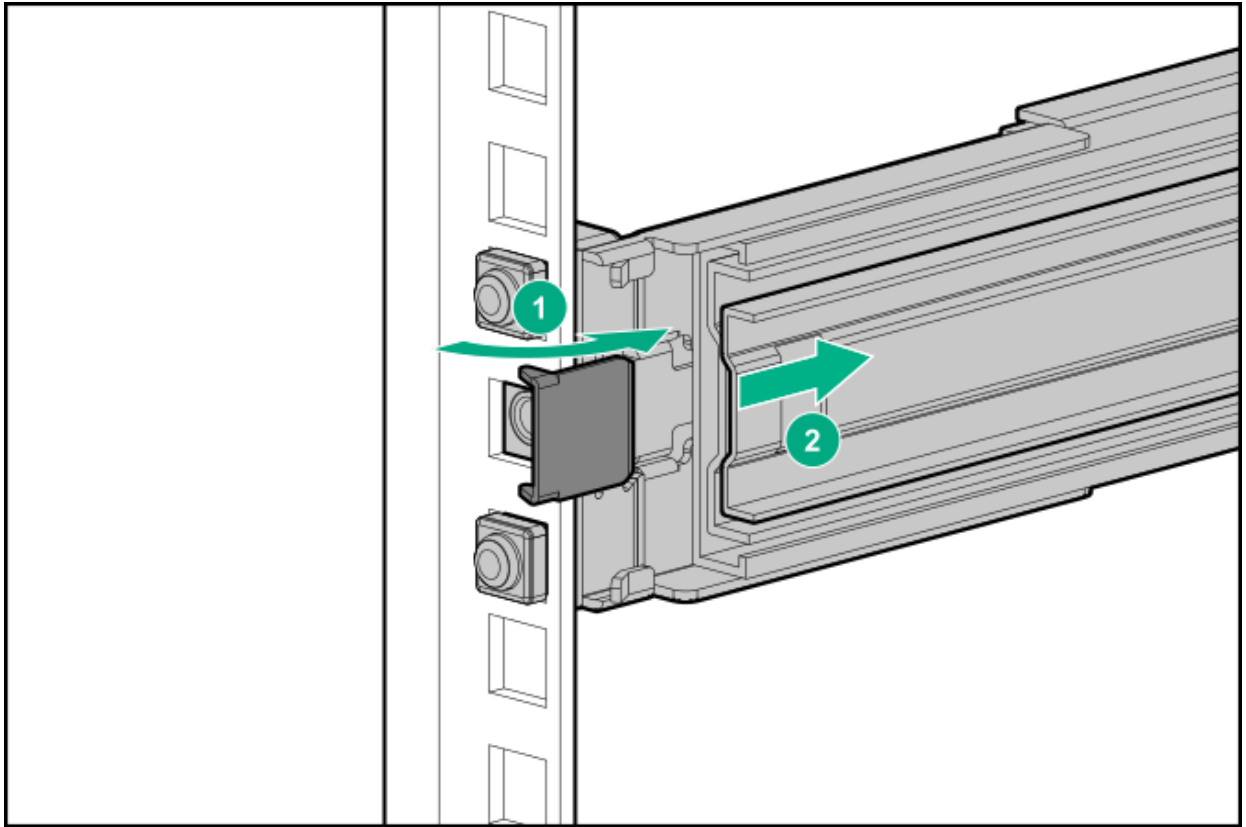

9. If you are replacing a rack sliding rail, do the following:
 - a. Slightly pull the rail latch to unlock the rail.
 - b. Slide the rail towards the front to disengage it from the alignment pins on the server tray, and then remove the rail from the server tray.

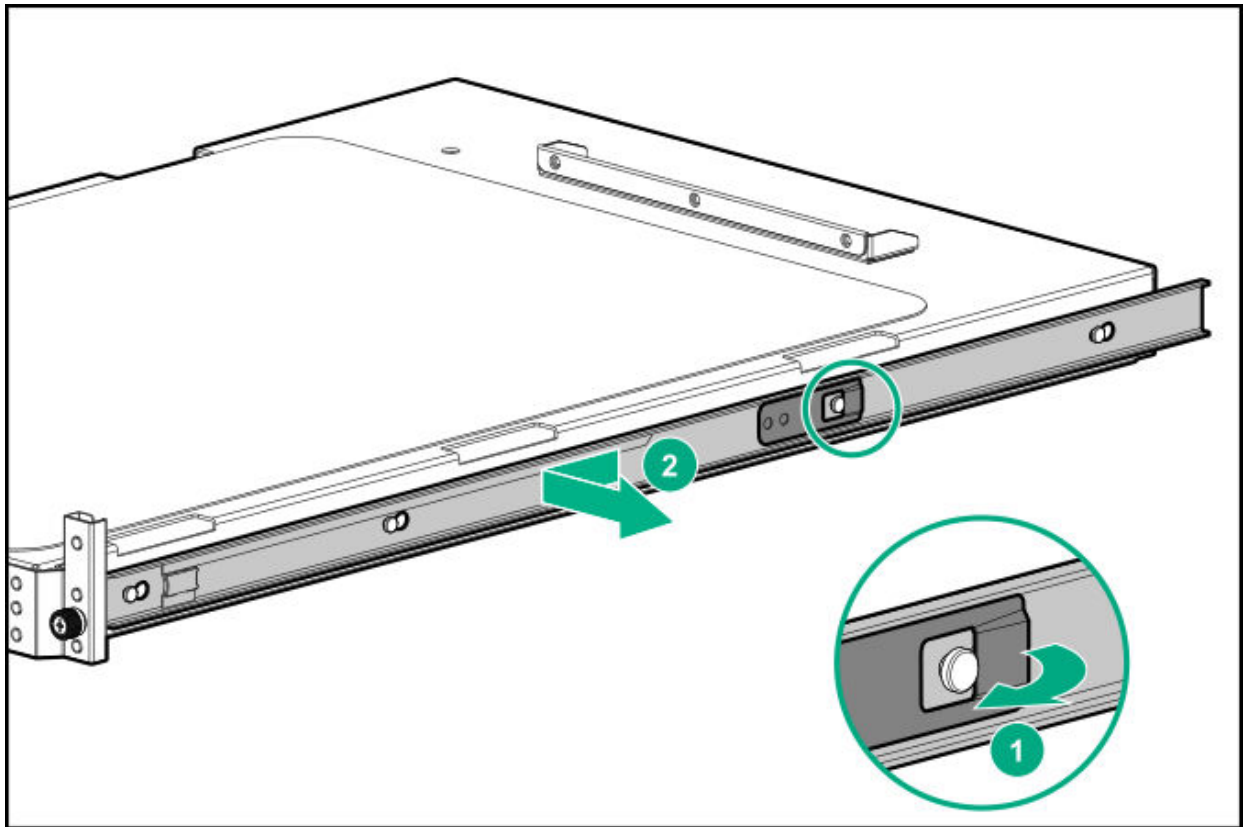

Results

The removal procedure is complete. To replace the component, reverse this procedure.

Media device replacement

Subtopics

[Removing and replacing a SAS LTO tape drive](#)

[Removing and replacing the optical drive](#)

Removing and replacing a SAS LTO tape drive

Prerequisites

Before you perform this procedure, make sure that you have a T-15 Torx screwdriver available.

About this task



CAUTION

A discharge of static electricity from a finger or other conductor might damage system boards or other static-sensitive devices. To prevent damage, observe antistatic precautions.



CAUTION

To prevent improper cooling and thermal damage, do not operate the server unless all bays are populated with either a component or a blank.

Procedure

1. Remove the front bezel.
2. Power down the server.
3. Remove all power:
 - a. Disconnect each power cord from the power source.
 - b. Disconnect each power cord from the server.
4. Disconnect all peripheral cables from the server.
5. If the server is in tower mode, place the server on a flat, level surface with the access panel facing up.
6. If the server is in rack mode, do one of the following:
 - Extend the server from the rack.
 - Remove the server from the rack.
7. Remove the access panel.
8. Remove the fan cage.
9. Disconnect the drive power and SAS cables from the LTO tape drive.
10. Press and hold the release latch, and then slide the LTO tape drive out of the server.

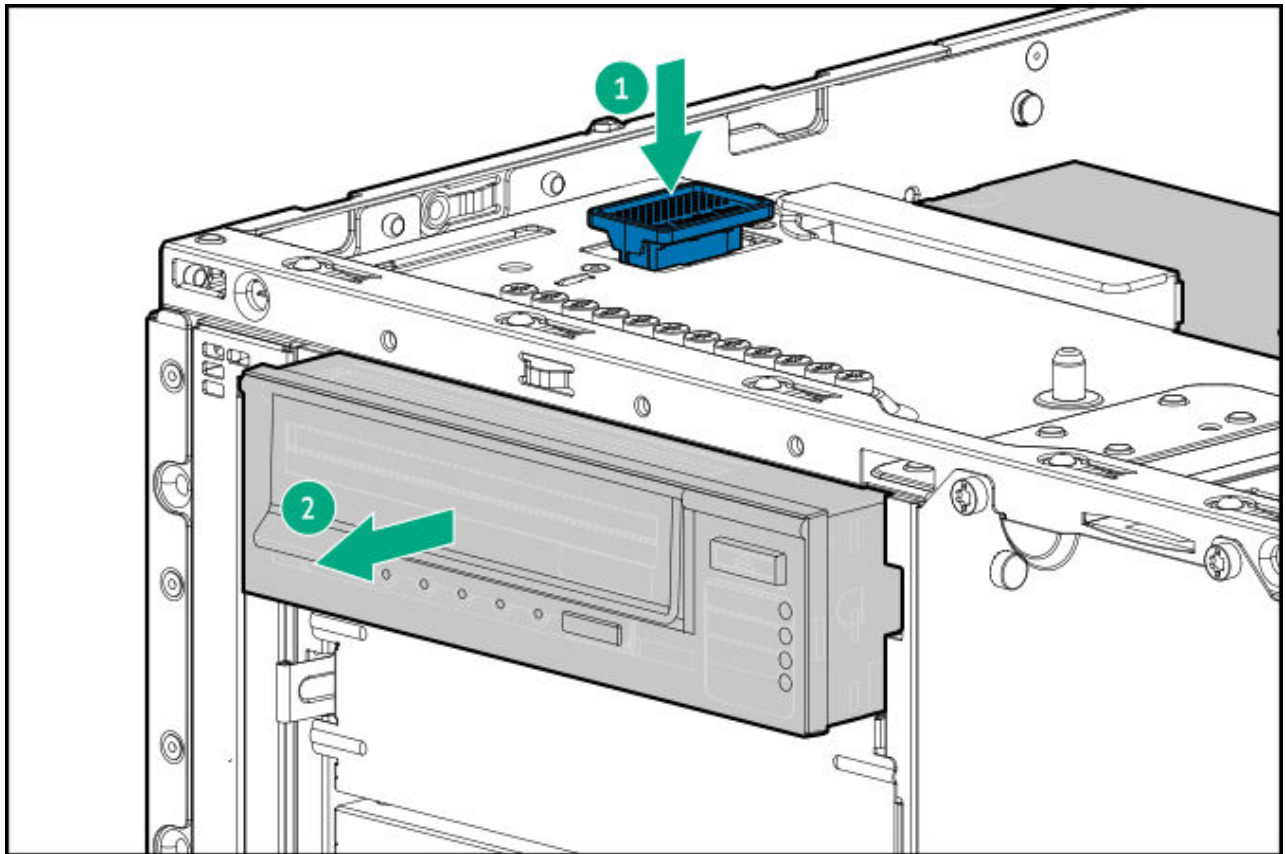

Results

The removal procedure is complete. To replace the component, reverse this procedure.

Before installing the replacement LTO tape drive in the media bay, install the mounting screws included in the spare kit on the tape drive.

Removing and replacing the optical drive

Prerequisites

Before you perform this procedure, make sure that you have the following items available:

- T-10 Torx screwdriver
- Phillips No. 1 screwdriver

About this task



CAUTION

A discharge of static electricity from a finger or other conductor might damage system boards or other static-sensitive devices. To prevent damage, observe antistatic precautions.



CAUTION

To prevent improper cooling and thermal damage, do not operate the server unless all bays are populated with either a component or a blank.

Procedure

1. Remove the front bezel.
2. Power down the server.
3. Remove all power:
 - a. Disconnect each power cord from the power source.
 - b. Disconnect each power cord from the server.
4. Disconnect all peripheral cables from the server.
5. If the server is in tower mode, place the server on a flat, level surface with the access panel facing up.
6. If the server is in rack mode, do one of the following:
 - Extend the server from the rack.
 - Remove the server from the rack.
7. Remove the access panel.
8. Remove the fan cage.
9. Disconnect the optical drive cable from the optical drive.
0. Disconnect the front I/O cables from the system board.
- .1. Remove the front I/O cage:
 - a. Remove the front I/O cage screws.
 - b. Slide the front I/O cage out of the server.

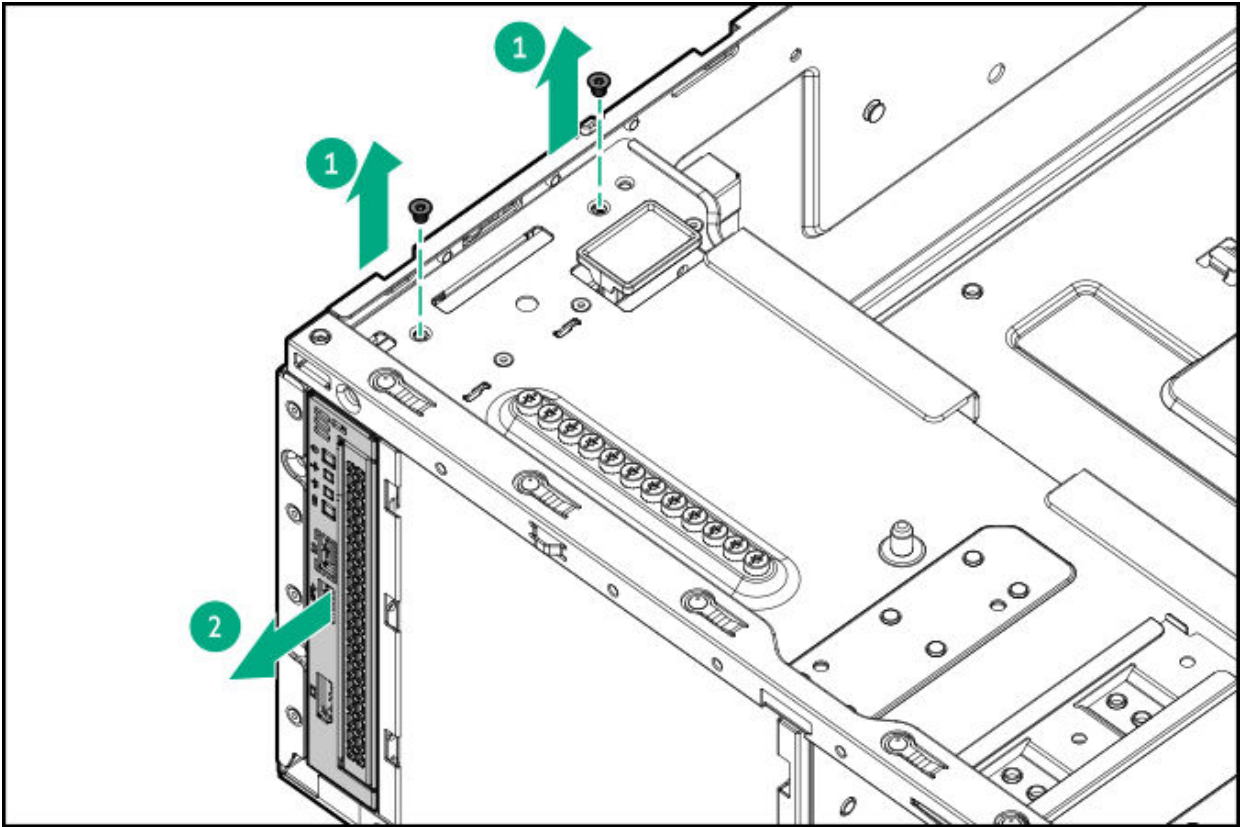

- .2. Remove the optical drive from the front I/O cage:
 - a. Remove the drive bracket screw.
 - b. Slide the optical drive out of the front I/O cage.

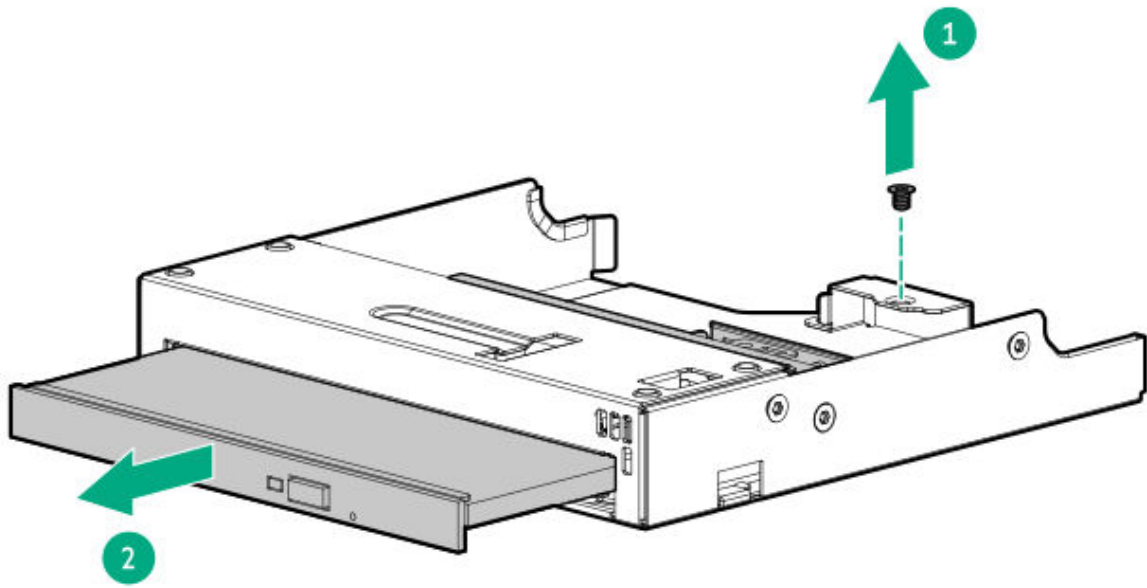

3. Remove the optical drive bracket.

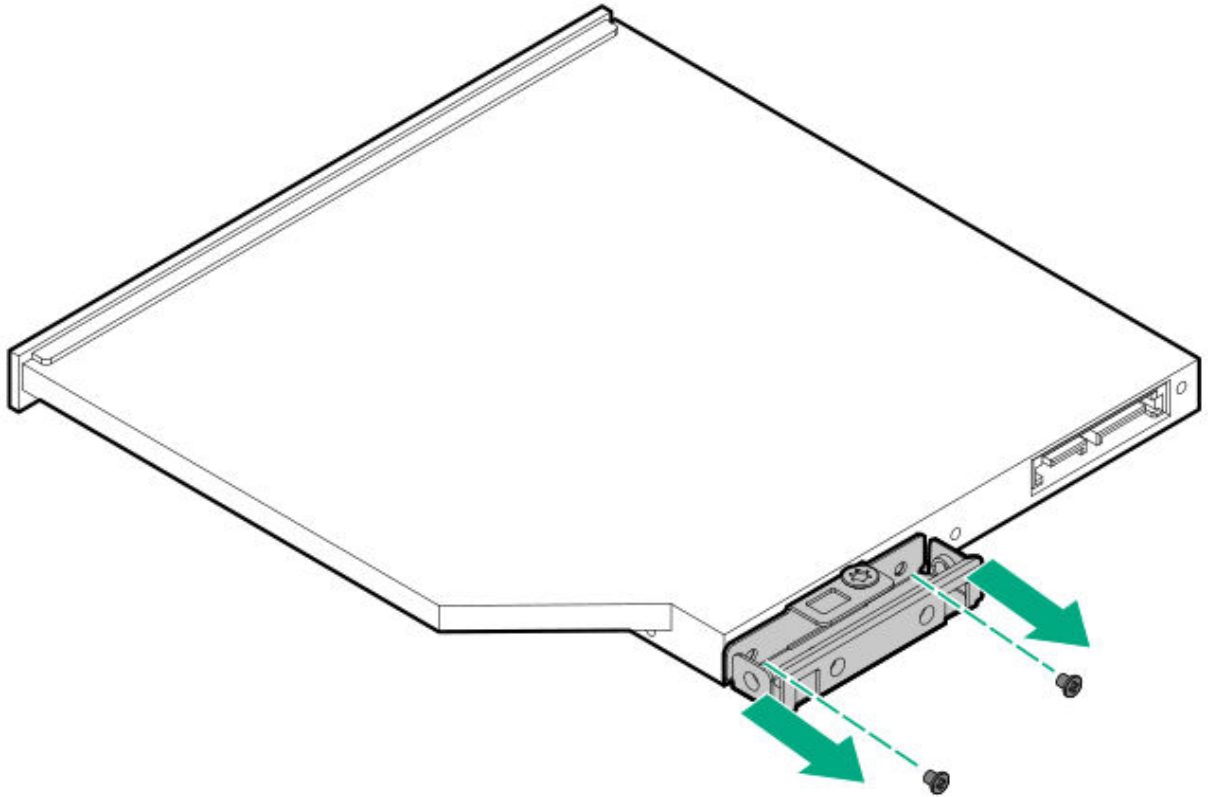

Results

The removal procedure is complete. To replace the component, reverse this procedure.

Removing and replacing the front I/O module

Prerequisites

Before you perform this procedure, make sure that you have a T-10 Torx screwdriver available.

About this task

https://sketchfab.com/models/39171ff45504474a9a4d83c05290b04a/embed?ui_infos=0&ui_watermark=0&ui_help=0&ui_vr=0&ui_settings=0&ui_inspector=0&ui_hint=2&ui_color=01a982&ui_theme=dark&autostart=1&camera=0&

Procedure

1. Remove the front bezel.

2. Power down the server.
3. Remove all power:
 - a. Disconnect each power cord from the power source.
 - b. Disconnect each power cord from the server.
4. Disconnect all peripheral cables from the server.
5. If the server is in tower mode, place the server on a flat, level surface with the access panel facing up.
6. If the server is in rack mode, do one of the following:
 - Extend the server from the rack.
 - Remove the server from the rack.
7. Remove the access panel.
8. Remove the fan cage.
9. Remove the primary riser cage.
0. Disconnect the front I/O cables from the system board.
- .1. If installed, disconnect the SATA-power Y-cable from the optical drive.
- .2. Remove the front I/O module:
 - a. Remove the front I/O cage screws.
 - b. Remove the front I/O module from the chassis.

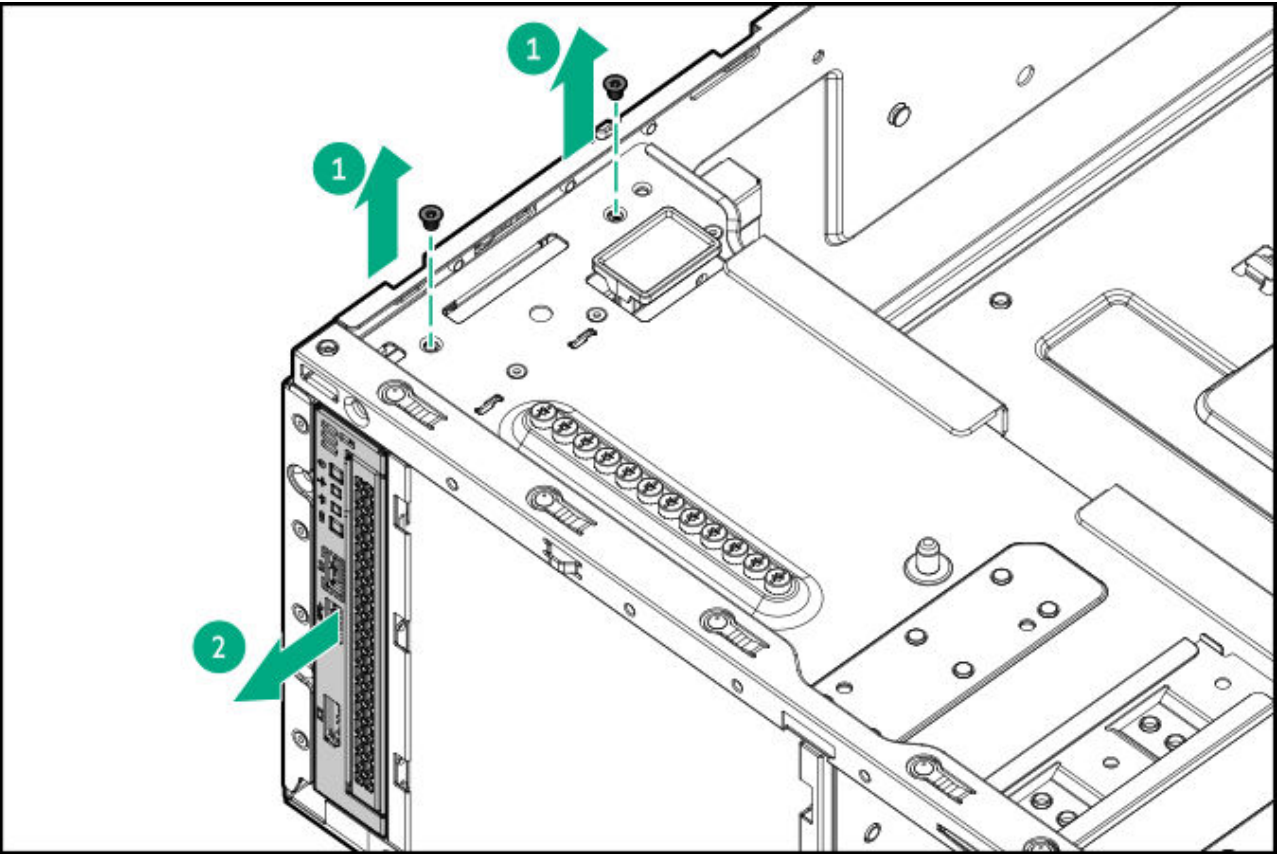

.3. If installed, remove the optical drive.

Results

The removal procedure is complete. To replace the component, reverse this procedure.

When installing the new front I/O cable to the system board, route the cable along the right DIMM guard.

Drive backplane replacement

Subtopics

Removing and replacing the 4 LFF drive backplane

Removing and replacing the 8 SFF drive backplane

Removing and replacing the 4 E3.S drive backplane

Removing and replacing the 4 LFF drive backplane

Prerequisites

Before you perform this procedure, make sure that you have a T-15 Torx screwdriver available.

About this task

https://sketchfab.com/models/61d8c8808b584d88b47026a501fe2bff/embed?ui_infos=0&ui_watermark=0&ui_help=0&ui_vr=0&ui_settings=0&ui_inspector=0&ui_hint=2&ui_color=01a982&ui_theme=dark&autostart=1&camera=0&



CAUTION

A discharge of static electricity from a finger or other conductor might damage system boards or other static-sensitive devices. To prevent damage, observe antistatic precautions.

Procedure

1. Remove the front bezel.
2. Remove all drives.
3. Power down the server.
4. Remove all power:
 - a. Disconnect each power cord from the power source.
 - b. Disconnect each power cord from the server.
5. Disconnect all peripheral cables from the server.
6. If the server is in tower mode, place the server on a flat, level surface with the access panel facing up.
7. If the server is in rack mode, do one of the following:
 - Extend the server from the rack.
 - Remove the server from the rack.
8. Remove the access panel.
9. Disconnect all cables from the drive backplane.
10. Remove 4 LFF drive cage:
 - a. Remove the screws.

b. Remove the drive cage from the server.

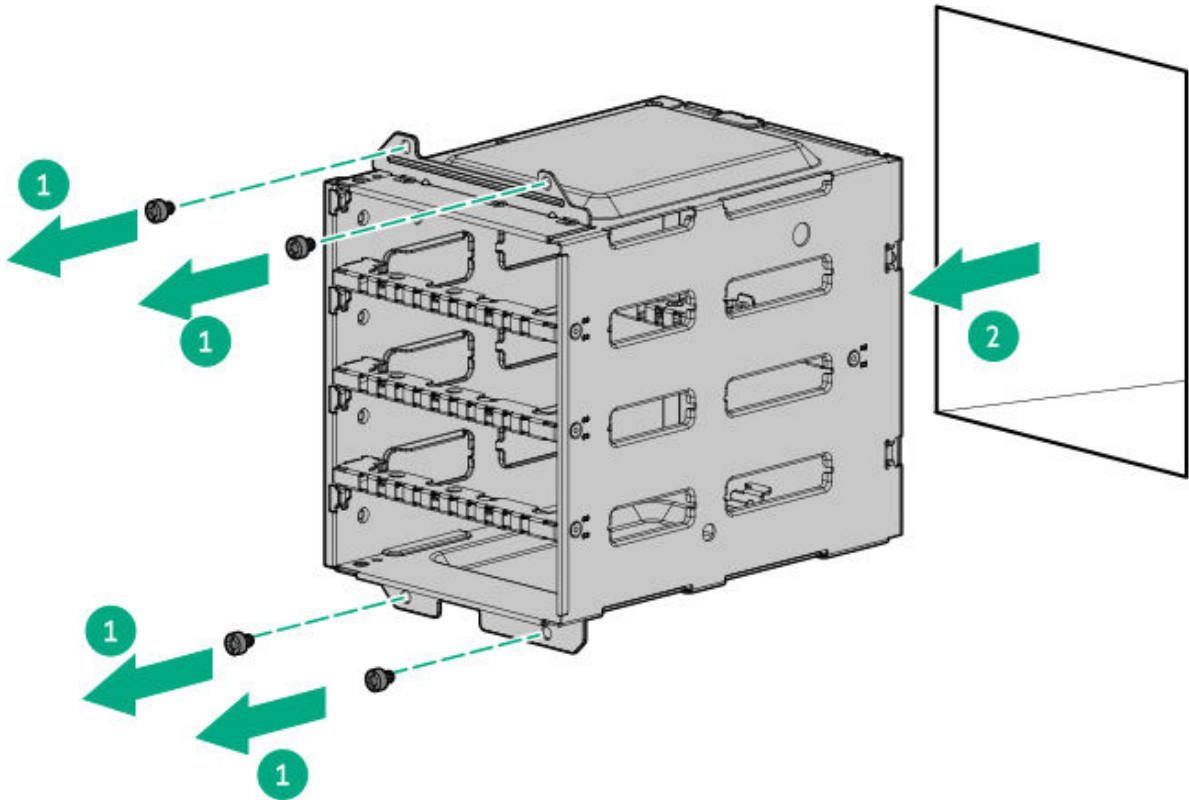

.1. Remove the 4 LFF drive backplane.

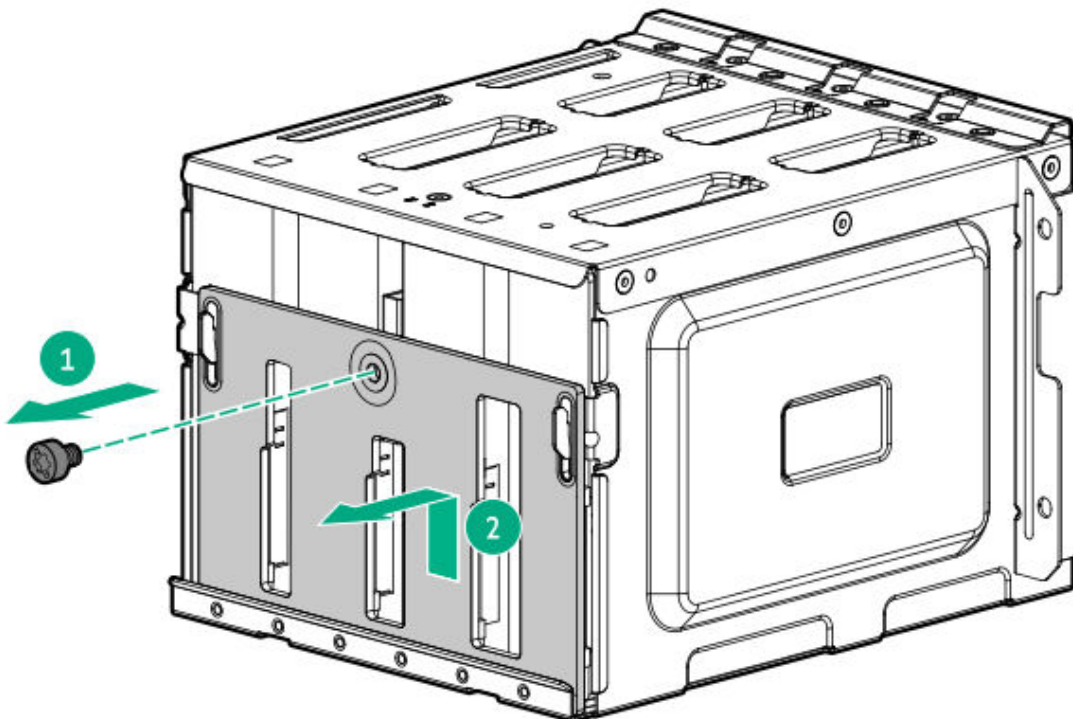

Results

The removal procedure is complete. To replace the component, reverse this procedure.

Removing and replacing the 8 SFF drive backplane

Prerequisites

Before you perform this procedure, make sure that you have a T-15 Torx screwdriver available.

About this task

https://sketchfab.com/models/63dd78e530424276a62f6d2e4bfcc65a/embed?ui_infos=0&ui_watermark=0&ui_help=0&ui_vr=0&ui_settings=0&ui_inspector=0&ui_hint=2&ui_color=01a982&ui_theme=dark&autostart=1&camera=0&



CAUTION

A discharge of static electricity from a finger or other conductor might damage system boards or other static-sensitive devices. To prevent damage, observe antistatic precautions.

Procedure

1. Remove the front bezel.
2. Remove all drives.
3. Power down the server.
4. Remove all power:
 - a. Disconnect each power cord from the power source.
 - b. Disconnect each power cord from the server.
5. Disconnect all peripheral cables from the server.
6. If the server is in tower mode, place the server on a flat, level surface with the access panel facing up.
7. If the server is in rack mode, do one of the following:
 - Extend the server from the rack.
 - Remove the server from the rack.
8. Remove the access panel.

9. Disconnect all cables from the drive backplane.
10. Remove the 8 SFF drive cage:
 - a. Remove the screws.
 - b. Remove the drive cage from the server.

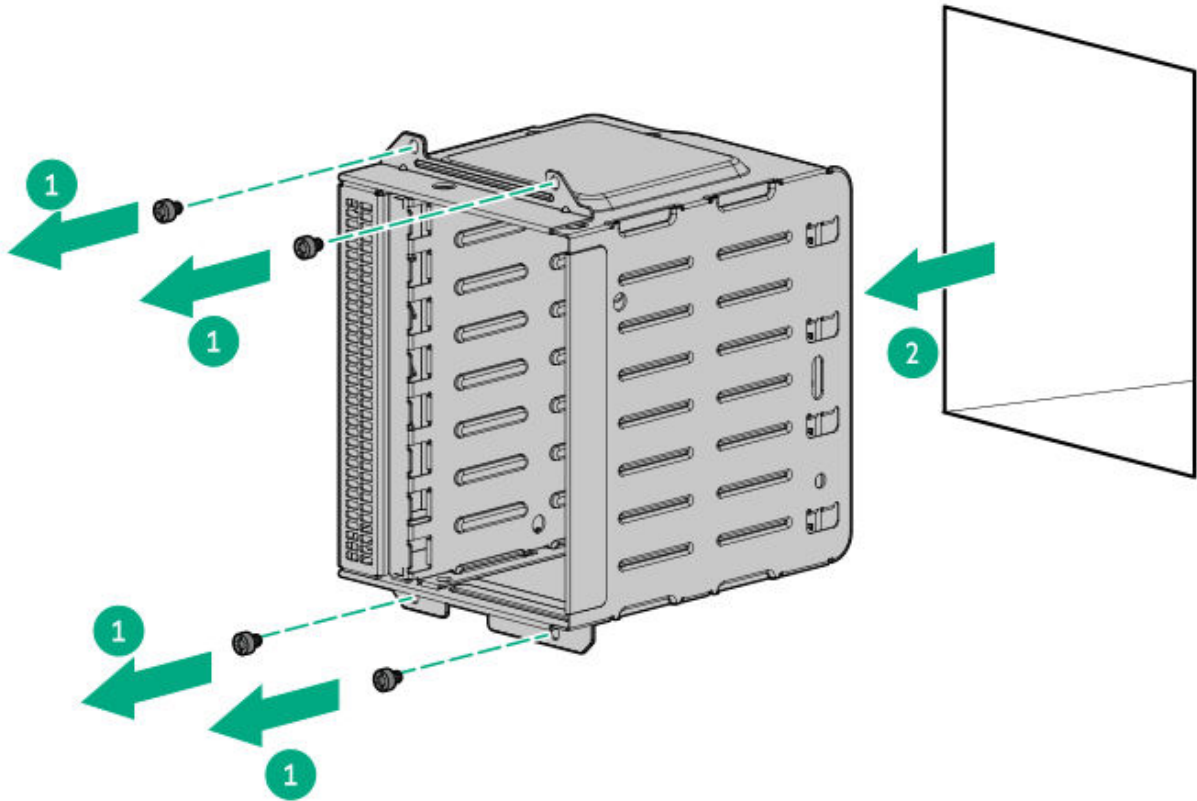

11. Remove the 8 SFF drive backplane.

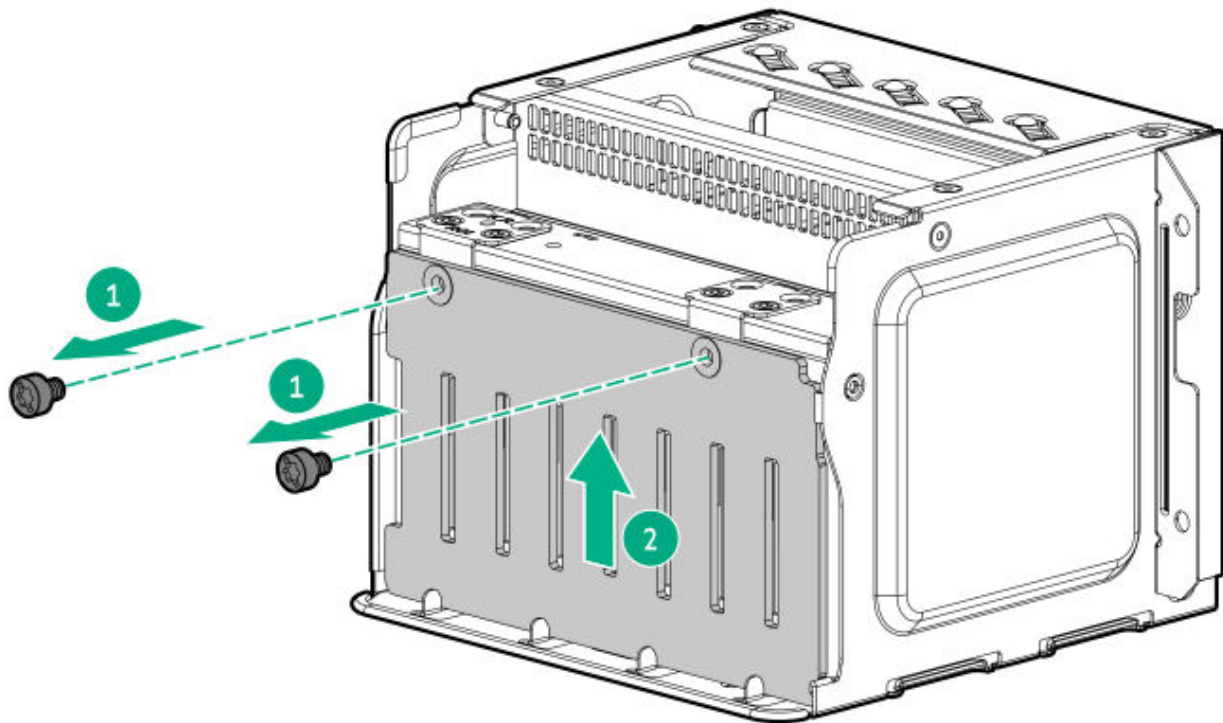

Results

The removal procedure is complete. To replace the component, reverse this procedure.

Removing and replacing the 4 E3.S drive backplane

Prerequisites

Before you perform this procedure, make sure that you have a T-15 Torx screwdriver available.

About this task

https://sketchfab.com/models/8e1e1e12a92d4c7d99c502c2b66fec97/embed?ui_infos=0&ui_watermark=0&ui_help=0&ui_vr=0&ui_settings=0&ui_inspector=0&ui_hint=2&ui_color=01a982&ui_theme=dark&autostart=1&camera=0&



CAUTION

A discharge of static electricity from a finger or other conductor might damage system boards or other static-sensitive devices. To prevent damage, observe [antistatic precautions](#).

Procedure

1. Remove the front bezel.
2. Remove all drives.
3. Power down the server.
4. Remove all power:
 - a. Disconnect each power cord from the power source.
 - b. Disconnect each power cord from the server.
5. Disconnect all peripheral cables from the server.
6. If the server is in tower mode, place the server on a flat, level surface with the access panel facing up.
7. If the server is in rack mode, remove the server from the rack.
8. Remove the access panel.
9. Disconnect all cables from the drive backplane.
10. Remove the 12 E3.S drive cage:
 - a. Remove the screws.
 - b. Remove the drive cage from the server.

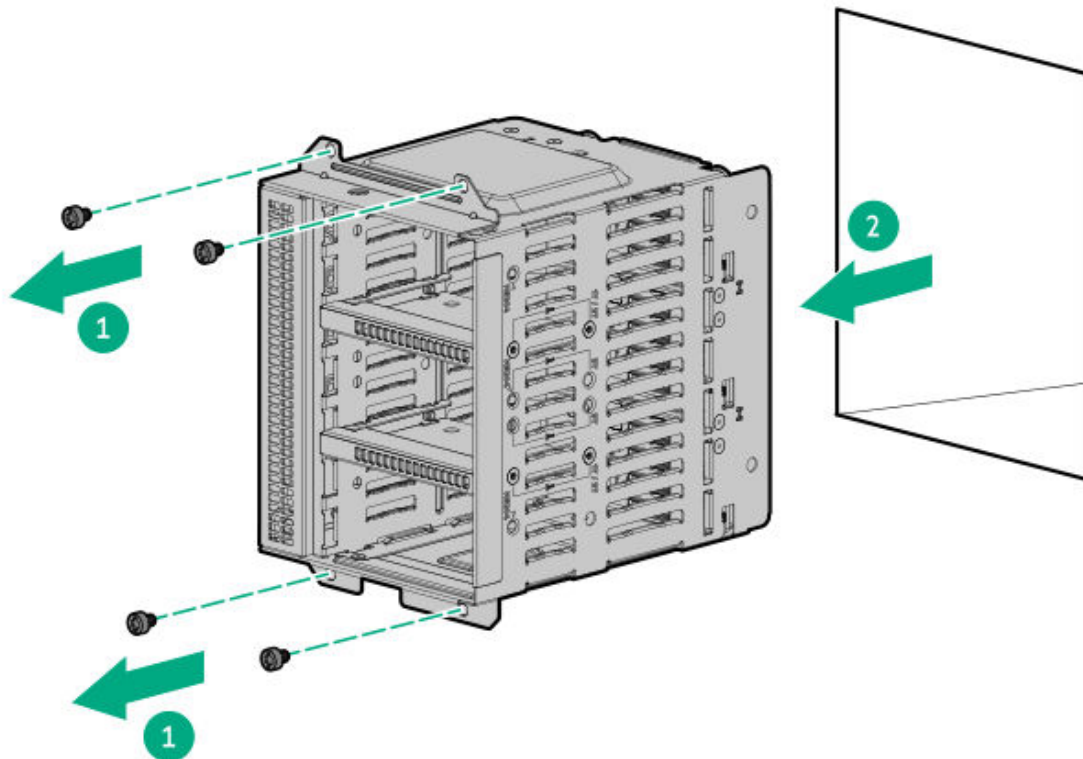

.1. Remove the 4 E3.S drive backplane.

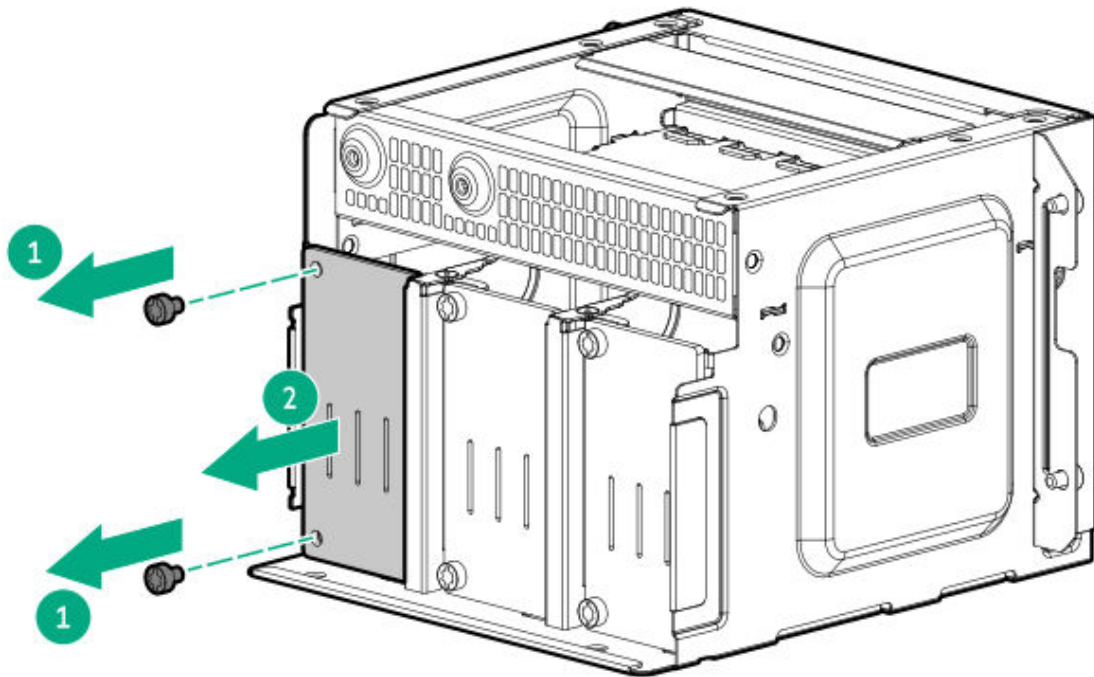

Results

The removal procedure is complete. To replace the component, reverse this procedure.

Fan replacement

Subtopics

Fan population

Removing and replacing the internal fan in hot-plug mode

Removing and replacing the internal fan in non-hot-plug mode

Removing and replacing the external fan

Fan population

- In a single-processor system, nonredundant configuration, fans 2–4 are preinstalled in the fan cage and a fan blank is preinstalled in bay 1.
- In a dual-processor system, nonredundant configuration requires a fan in bay 1.
- To enable redundant fan mode in single- and dual-processor systems, install fans in bay 1, 5–8.
- In the E3.S drive configuration, the external fan 10 is default in the server.
- When installing GPU options in the primary and secondary risers, external fans 9–10 covering the rear side of riser slots are highly recommended.
- To maintain optimum system cooling, observe the following fan requirements for specific hardware components:

Hardware component	Bay 1	Bays 2–4	Bays 5–8	Bay 9	Bay 10	Fan redundancy
HPE NS204i-u Boot Device V2	Fan	Fan	—	—	—	Not supported
Tertiary riser	Fan	Fan	—	—	—	Not supported
Processor with a TDP of 300 W or higher	Fan	Fan	Fan	—	—	Supported
High power GPU in the primary riser	Fan	Fan	Fan	—	Fan 2	Supported
High power GPU in the secondary riser	Fan	Fan	Fan	Fan 2	—	Supported
E3.S drives	Fan	Fan	Fan	—	Fan	Supported
256 GB DIMM	Fan	Fan	Fan	—	—	Supported
200 Gb or faster Ethernet/InfiniBand adapter	Fan	Fan	Fan	—	—	Supported

- 1 For limited operating inlet ambient temperature requirements when GPUs are installed, see the server QuickSpecs on the Hewlett Packard Enterprise website (<https://www.hpe.com/info/quickspecs>).
- 2 For additional cooling support, Hewlett Packard Enterprise highly recommends installing an external fan.

Removing and replacing the internal fan in hot-plug mode

About this task

https://sketchfab.com/models/e6f9ad15ec3a4091b948f9e70456c3fe/embed?ui_infos=0&ui_watermark=0&ui_help=0&ui_vr=0&ui_settings=0&ui_inspector=0&ui_hint=2&ui_color=01a982&ui_theme=dark&autostart=1&camera=0&

Only the server in rack mode supports fan replacement in hot-plug mode.



CAUTION

To maintain proper system cooling, do not operate the server for long period with the access panel open or removed. Operating the server in this manner results in an improper system airflow. For internal hot-plug component procedures, complete the procedure within 60 seconds. Failure to do so can cause the system temperature to increase and trip the safety threshold. When this happens:

- The health LED flashes amber.
- The operating system gracefully shuts down.

Procedure

1. Extend the server from the rack.
2. Unlock the front bezel.
3. Unlock the front bezel.
4. Remove the access panel.
5. Press and hold the latch, and then lift the fan from the bay.

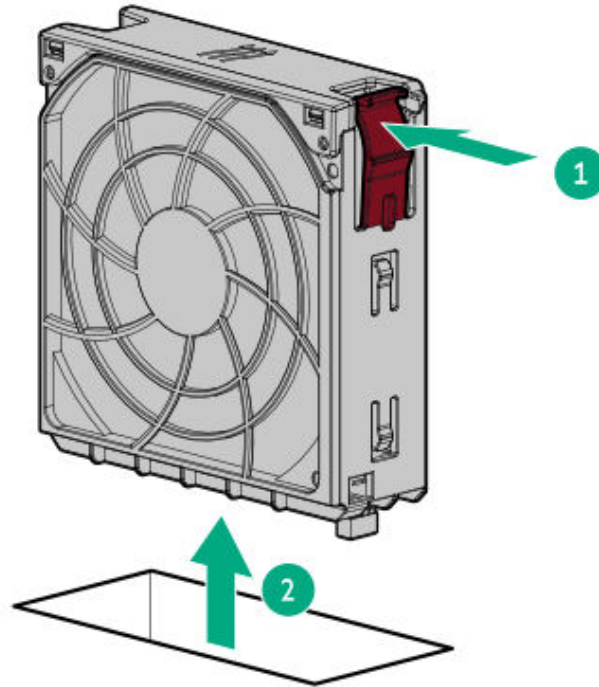

Results

The removal procedure is complete. To replace the component, reverse this procedure.

When installing the fan replacement, make sure that the fan clicks into place.

Removing and replacing the internal fan in non-hot-plug mode

About this task

https://sketchfab.com/models/e6f9ad15ec3a4091b948f9e70456c3fe/embed?ui_infos=0&ui_watermark=0&ui_help=0&ui_vr=0&ui_settings=0&ui_inspector=0&ui_hint=2&ui_color=01a982&ui_theme=dark&autostart=1&camera=0&



CAUTION

To prevent improper cooling and thermal damage, do not operate the server unless all bays are populated with either a component or a blank.

Procedure

1. Power down the server.
2. Remove all power:
 - a. Disconnect each power cord from the power source.
 - b. Disconnect each power cord from the server.
3. Disconnect all peripheral cables from the server.
4. If the server is in tower mode, place the server on a flat, level surface with the access panel facing up.
5. If the server is in rack mode, do one of the following:
 - Extend the server from the rack.
 - Remove the server from the rack.
6. Unlock the front bezel.
7. Remove the access panel.
8. Press and hold the latch, and then lift the fan from the bay.

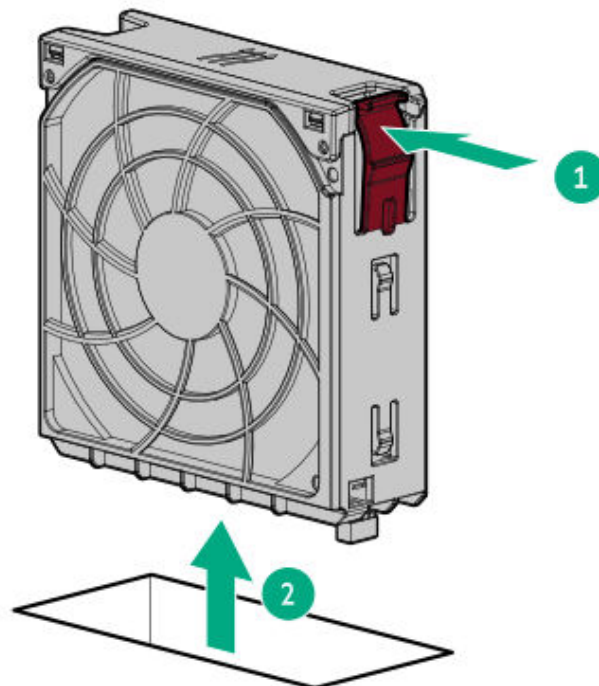

Results

The removal procedure is complete. To replace the component, reverse this procedure.

When installing the fan replacement, make sure that the fan clicks into place.

Removing and replacing the external fan

Prerequisites

Before you perform this procedure, make sure that you have a T-15 Torx screwdriver available.

About this task

https://sketchfab.com/models/55e98828246d4e78bca341d26e39d206/embed?ui_infos=0&ui_watermark=0&ui_help=0&ui_vr=0&ui_settings=0&ui_inspector=0&ui_hint=2&ui_color=01a982&ui_theme=dark&autostart=1&camera=0&



CAUTION

To prevent improper cooling and thermal damage, do not operate the server unless all bays are populated with either a component or a blank.

Procedure

1. Power down the server.
2. Remove all power:
 - a. Disconnect each power cord from the power source.
 - b. Disconnect each power cord from the server.
3. Disconnect all peripheral cables from the server.
4. If the server is in tower mode, place the server on a flat, level surface with the access panel facing up.
5. If the server is in rack mode, do one of the following:
 - Extend the server from the rack.
 - Remove the server from the rack.
6. Remove the external fan:
 - a. Loosen the captive screws.

- b. Remove the external fan from the bay.

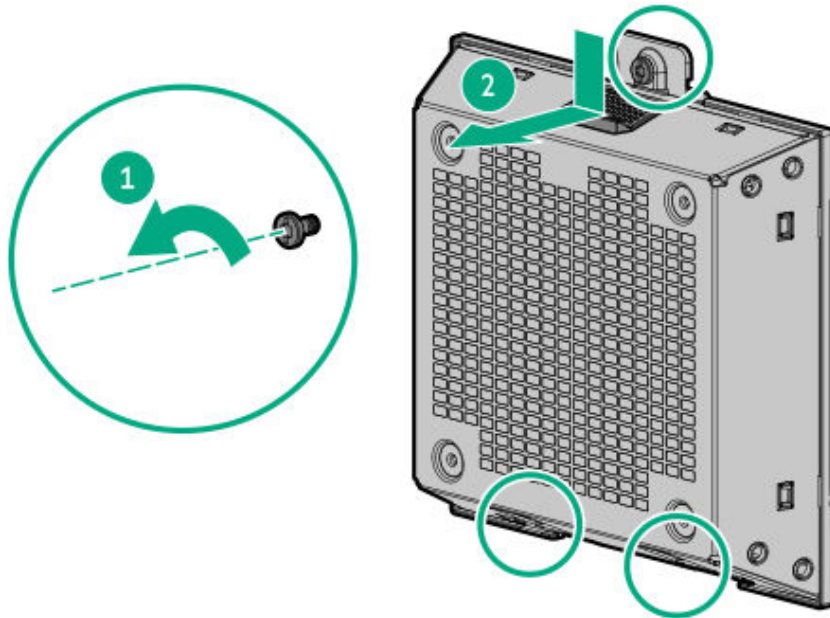

Results

The removal procedure is complete. To replace the component, reverse this procedure.

Removing and replacing the fan blank

About this task



CAUTION

To prevent improper cooling and thermal damage, do not operate the server unless all bays are populated with either a component or a blank.

Procedure

1. Power down the server.
2. Remove all power:

- a. Disconnect each power cord from the power source.
- b. Disconnect each power cord from the server.
3. Disconnect all peripheral cables from the server.
4. If the server is in tower mode, place the server on a flat, level surface with the access panel facing up.
5. If the server is in rack mode, do one of the following:
 - Extend the server from the rack.
 - Remove the server from the rack.
6. Unlock the front bezel.
7. Remove the access panel.
8. Remove the fan blank.

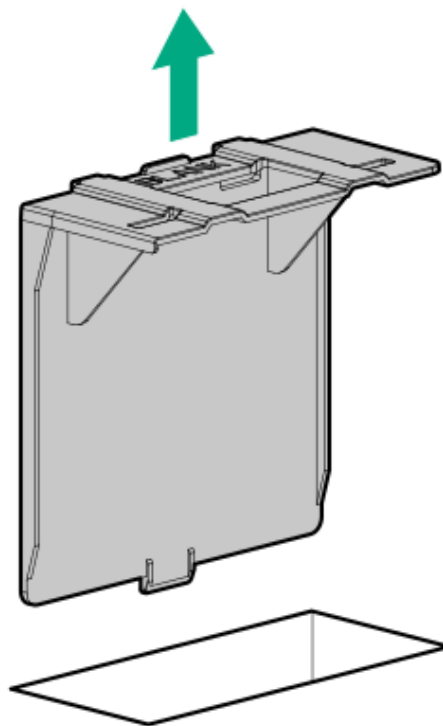

Results

The removal procedure is complete. To replace the component, reverse this procedure.

Removing and replacing the fan cage

About this task

https://sketchfab.com/models/73f5c2a4bd494924a35f1512501c429f/embed?ui_infos=0&ui_watermark=0&ui_help=0&ui_vr=0&ui_settings=0&ui_inspector=0&ui_hint=2&ui_color=01a982&ui_theme=dark&autostart=1&camera=0&

Procedure

1. Power down the server.
2. Remove all power:
 - a. Disconnect each power cord from the power source.
 - b. Disconnect each power cord from the server.
3. Disconnect all peripheral cables from the server.
4. If the server is in tower mode, place the server on a flat, level surface with the access panel facing up.
5. If the server is in rack mode, do one of the following:
 - Extend the server from the rack.
 - Remove the server from the rack.
6. Remove the access panel.
7. Press and hold the latch, and then lift the fan from the bay.

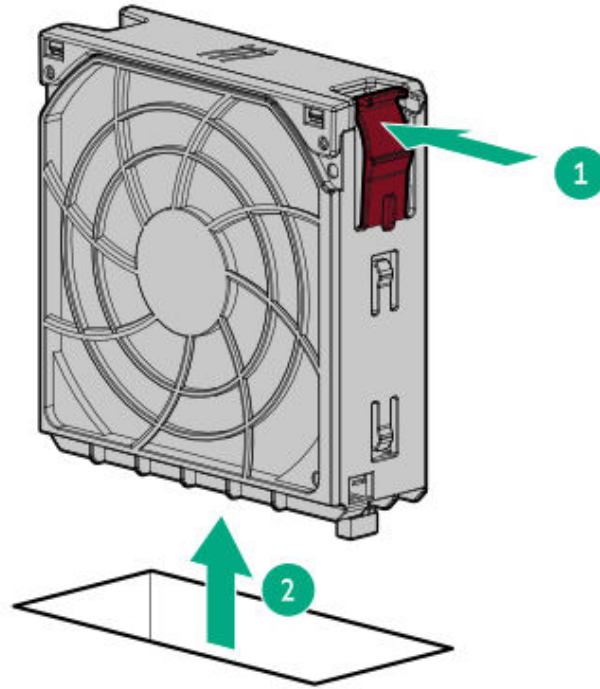

8. If installed, remove the fan blank from bay 1.

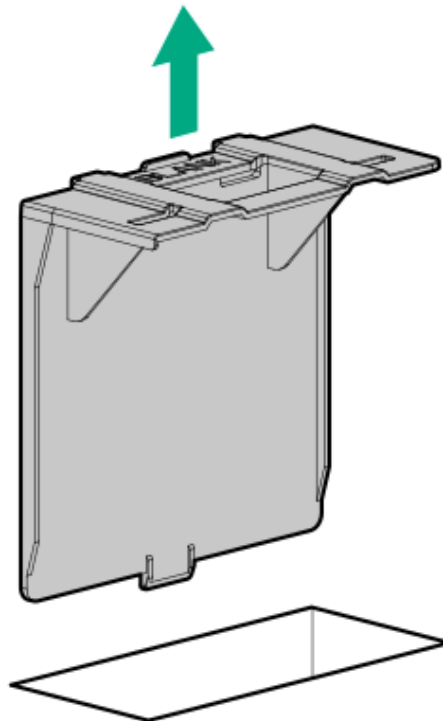

9. Disconnect the fan cage cables from the system board.
10. Remove the fan cage:
 - a. Open the fan cage latches.
 - b. Lift the fan cage away from the chassis.

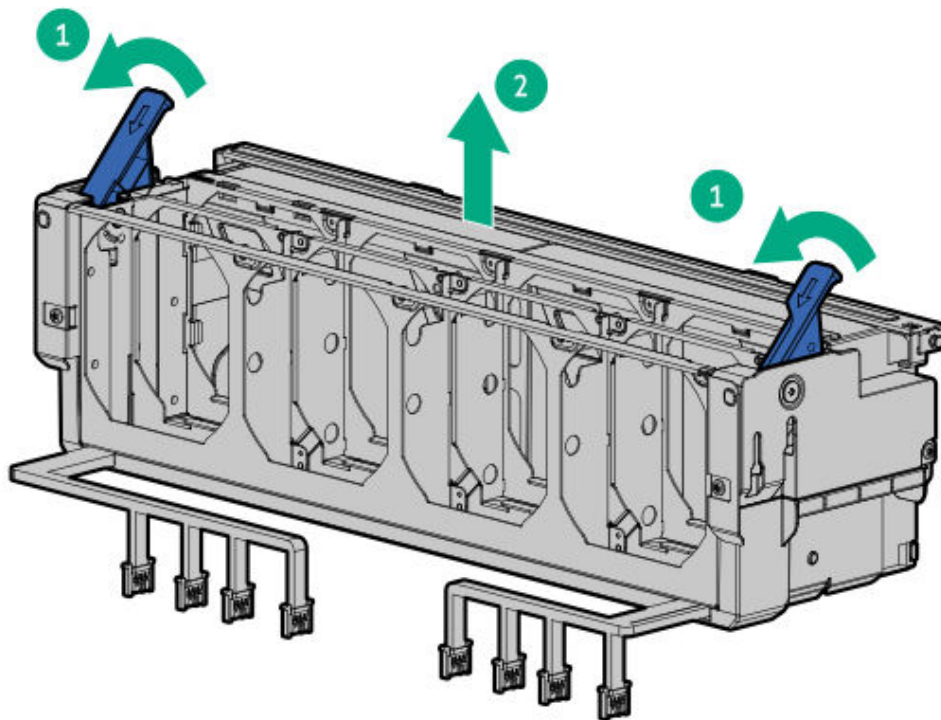

Results

The removal procedure is complete. To replace the component, reverse this procedure.

Removing and replacing the system board handle

Prerequisites

Before you perform this procedure, make sure that you have a T-10 Torx screwdriver available.

About this task

https://sketchfab.com/models/c64f10aa60624d3e9eaaee5285b5d2a9/embed?ui_infos=0&ui_watermark=0&ui_help=0&ui_vr=0&ui_settings=0&ui_inspector=0&ui_hint=2&ui_color=01a982&ui_theme=dark&autostart=1&camera=0&



WARNING

To reduce the risk of personal injury from hot surfaces, allow the drives and the internal system components to cool before touching them.



CAUTION

A discharge of static electricity from a finger or other conductor might damage system boards or other static-sensitive devices. To prevent damage, observe antistatic precautions.

Procedure

1. Power down the server.
2. Remove all power:
 - a. Disconnect each power cord from the power source.
 - b. Disconnect each power cord from the server.
3. Disconnect all peripheral cables from the server.
4. If the server is in tower mode, place the server on a flat, level surface with the access panel facing up.
5. If the server is in rack mode, remove the server from the rack.
6. Unlock the front bezel.
7. Remove the access panel.
8. If installed, remove the secondary riser cage.
9. Allow all internal system components to cool before continuing.
0. Remove the cable from the holder.
1. Remove the system board handle.

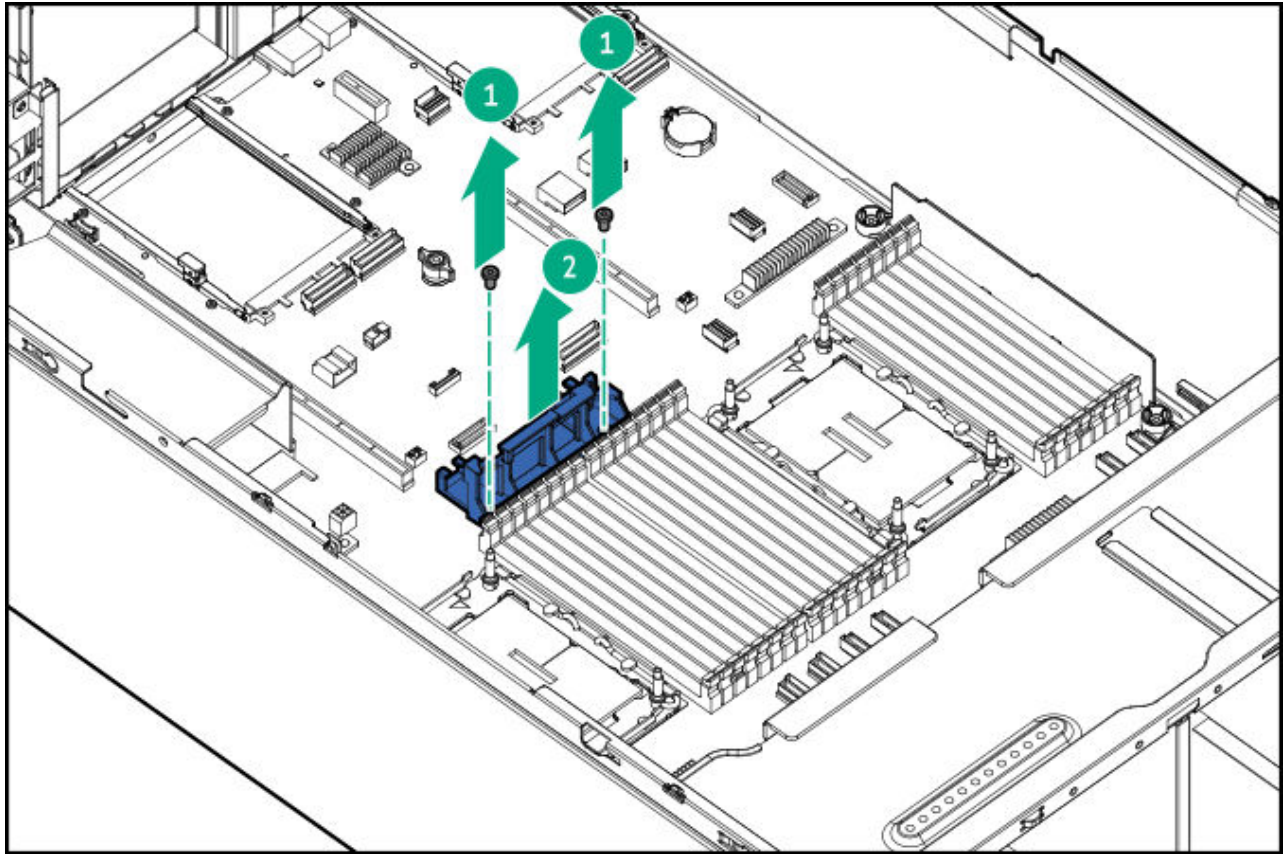

Results

The removal procedure is complete. To replace the component, reverse this procedure.

Removing and replacing a DIMM

About this task

- Standard heatsink

https://sketchfab.com/models/ec39e4183f8f410e93c8c34a1611b560/embed?ui_infos=0&ui_watermark=0&ui_help=0&ui_vr=0&ui_settings=0&ui_inspector=0&ui_hint=2&ui_color=01a982&ui_theme=dark&autostart=1&camera=0&

- Performance heatsink

<https://sketchfab.com/models/1c5d64e66cc9428fad4b17894ae4c32c/embed?>



CAUTION

Before replacing a DIMM, backplane, expansion card, riser board, or other similar PCA components due to a perceived hardware error, make sure first that the component is firmly seated in the slot.

When installing the replacement component:

- Observe antistatic precautions.
- Handle the PCA only along the edges.
- Do not touch the components and connectors on the PCA.
- Do not bend or flex the PCA.

Procedure

1. Back up all server data.
2. Power down the server.
3. Remove all power:
 - a. Disconnect each power cord from the power source.
 - b. Disconnect each power cord from the server.
4. Disconnect all peripheral cables from the server.
5. If the server is in tower mode, place the server on a flat, level surface with the access panel facing up.
6. If the server is in rack mode, do one of the following:
 - Extend the server from the rack.
 - Remove the server from the rack.
7. Unlock the front bezel.
8. Remove the access panel.
9. Remove the fan cage.
10. If remove the DIMM in the standard heatsink configuration:
 - a. Open the DIMM slot latches.

- b. Lift the DIMM out of the slot.

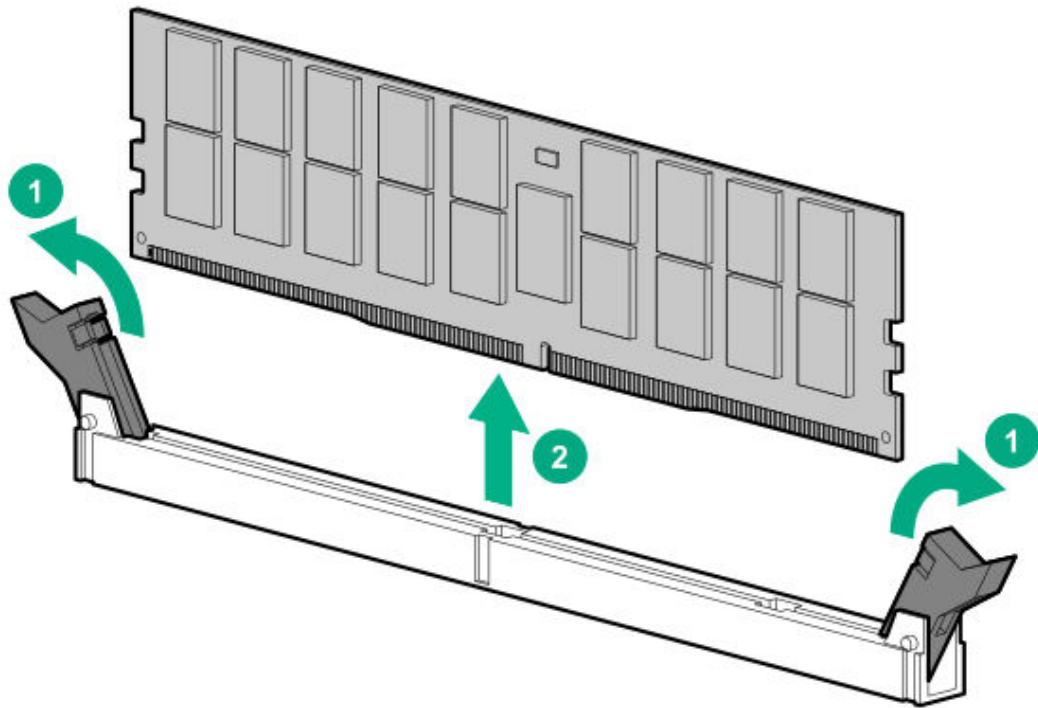

- .1. If remove the DIMM in the performance heatsink configuration:
 - a. Open the DIMM slot latches.
 - b. Lift the DIMM out of the slot.

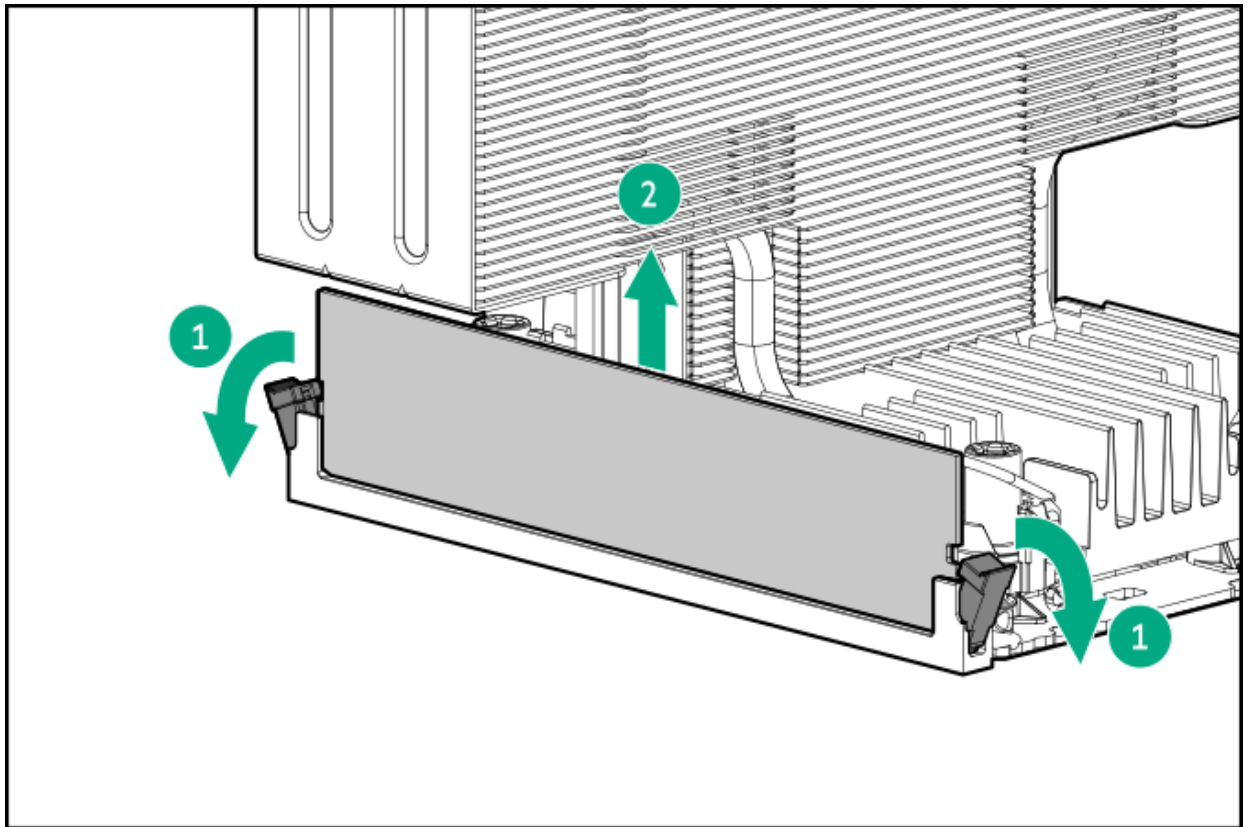

- c. Position the DIMM in a horizontal orientation and carefully slide the DIMM from the slot under the performance heatsink.

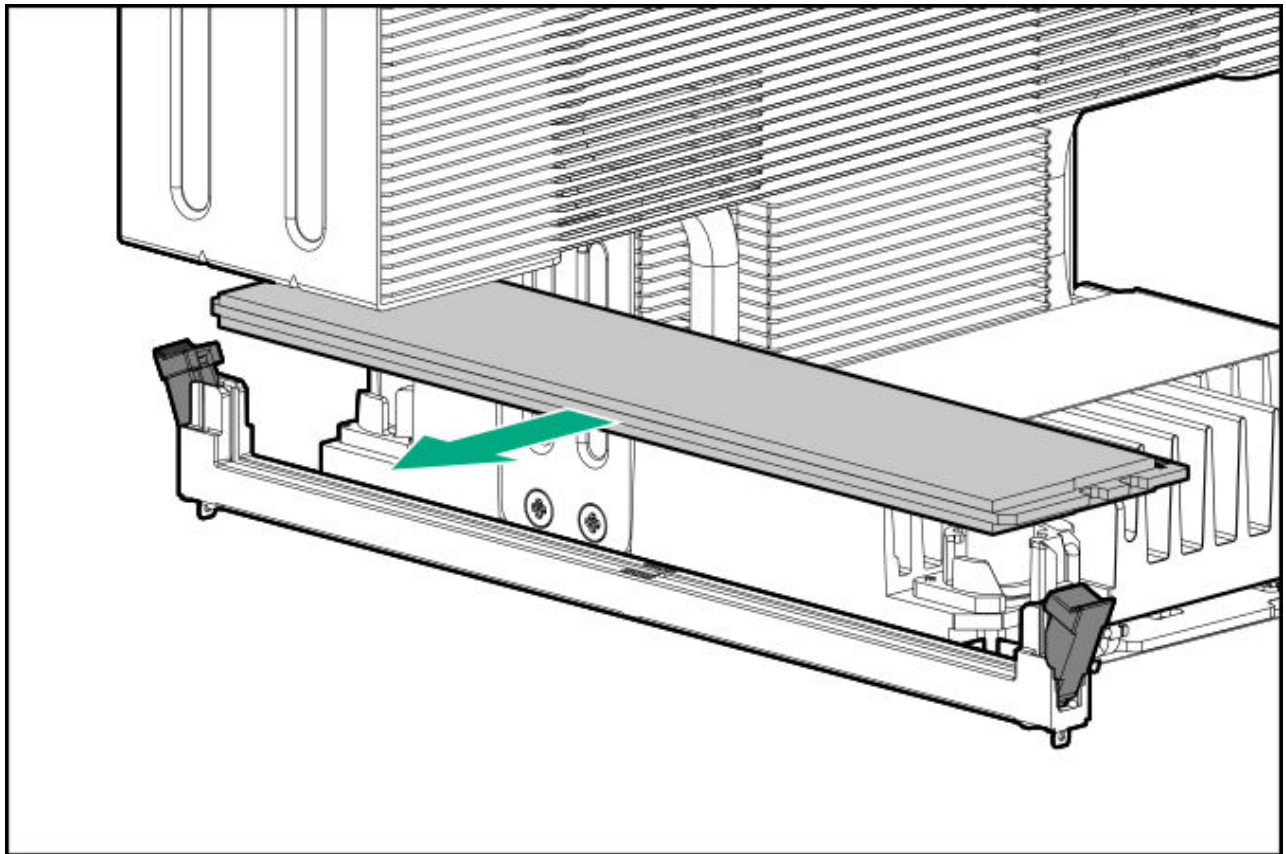

Results

The removal procedure is complete. To replace the component, reverse this procedure.

Removing and replacing a DIMM guard

Prerequisites

Before you perform this procedure, make sure that you have a T-15 Torx screwdriver available.

About this task

https://sketchfab.com/models/dc52addfa8ce438ea514a0a68e739d18/embed?ui_infos=0&ui_watermark=0&ui_help=0&ui_vr=0&ui_settings=0&ui_inspector=0&ui_hint=2&ui_color=01a982&ui_theme=dark&autostart=1&camera=0&

Procedure

1. [Power down the server.](#)

2. Remove all power:
 - a. Disconnect each power cord from the power source.
 - b. Disconnect each power cord from the server.
3. Disconnect all peripheral cables from the server.
4. If the server is in tower mode, place the server on a flat, level surface with the access panel facing up.
5. If the server is in rack mode, remove the server from the rack.
6. Unlock the front bezel.
7. Remove the access panel.
8. Remove the fan cage.
9. Remove the fan cage bracket.
0. Remove the cable clamp.
- .1. Remove the DIMM guard.

- Left

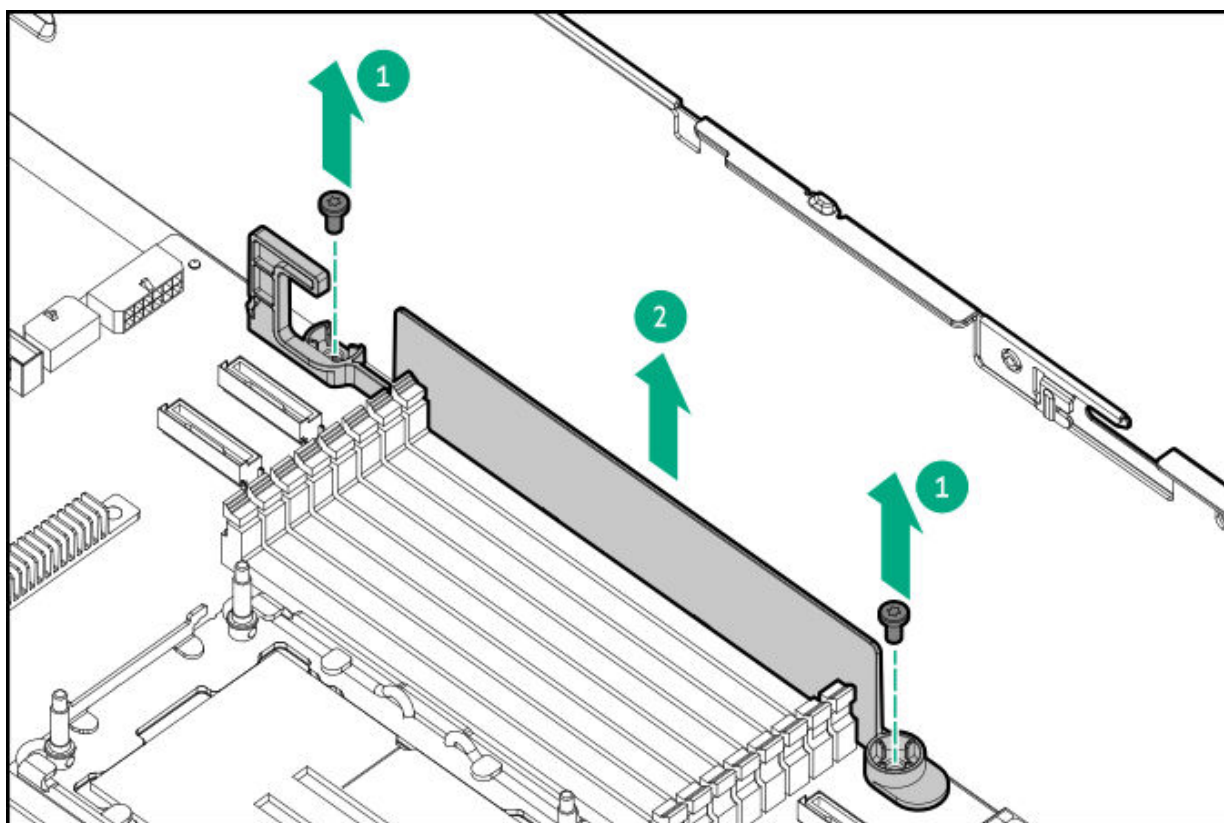

- Right

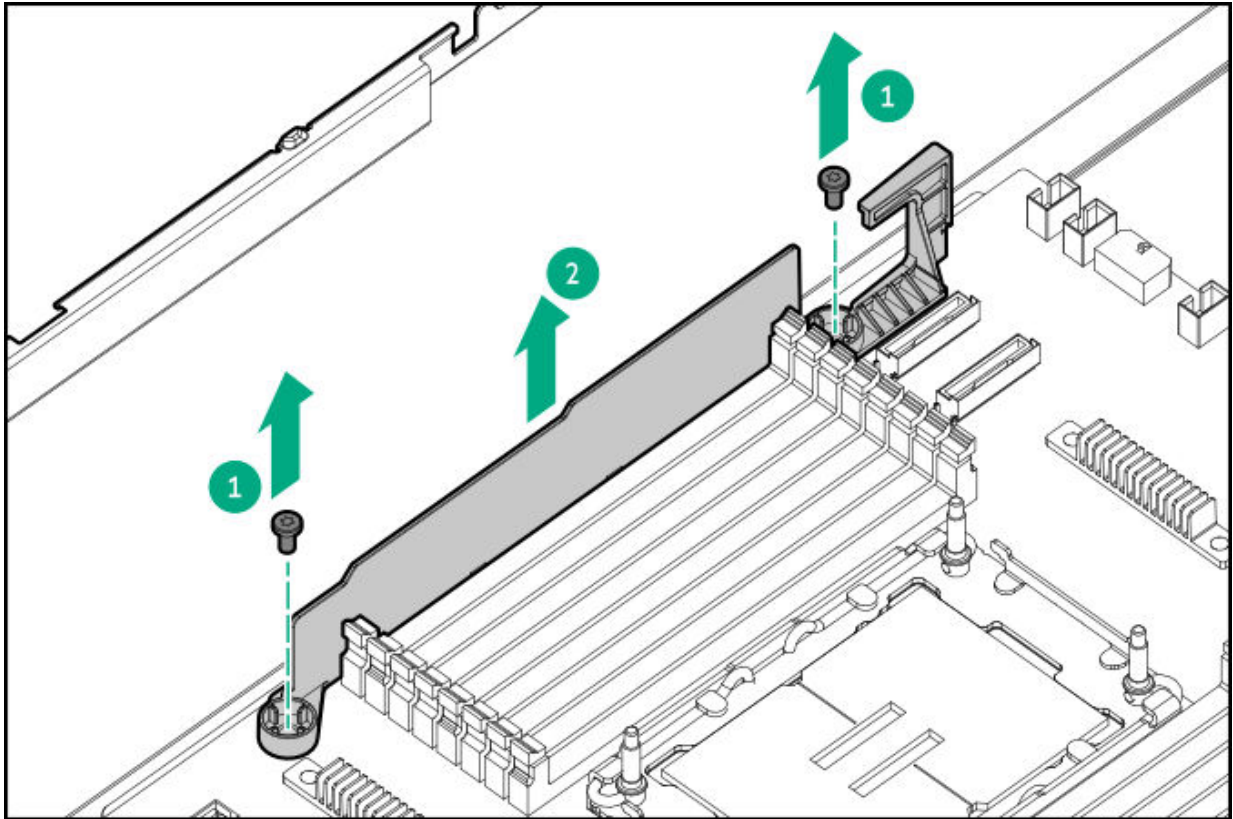

Results

The removal procedure is complete. To replace the component, reverse this procedure.

Removing and replacing the chassis intrusion detection switch

About this task

Procedure

1. Power down the server.
2. Remove all power:
 - a. Disconnect each power cord from the power source.
 - b. Disconnect each power cord from the server.
3. Disconnect all peripheral cables from the server.
4. If the server is in tower mode, place the server on a flat, level surface with the access panel facing up.
5. If the server is in rack mode, do one of the following:

- Extend the server from the rack.
 - Remove the server from the rack.
6. Unlock the front bezel.
 7. Remove the access panel.
 8. Remove the chassis intrusion detection switch:
 - a. Disconnect the switch cable and release it from the cable clamp.
 - b. While carefully retracting the snap-in latch, pull out the tab from the chassis slot.

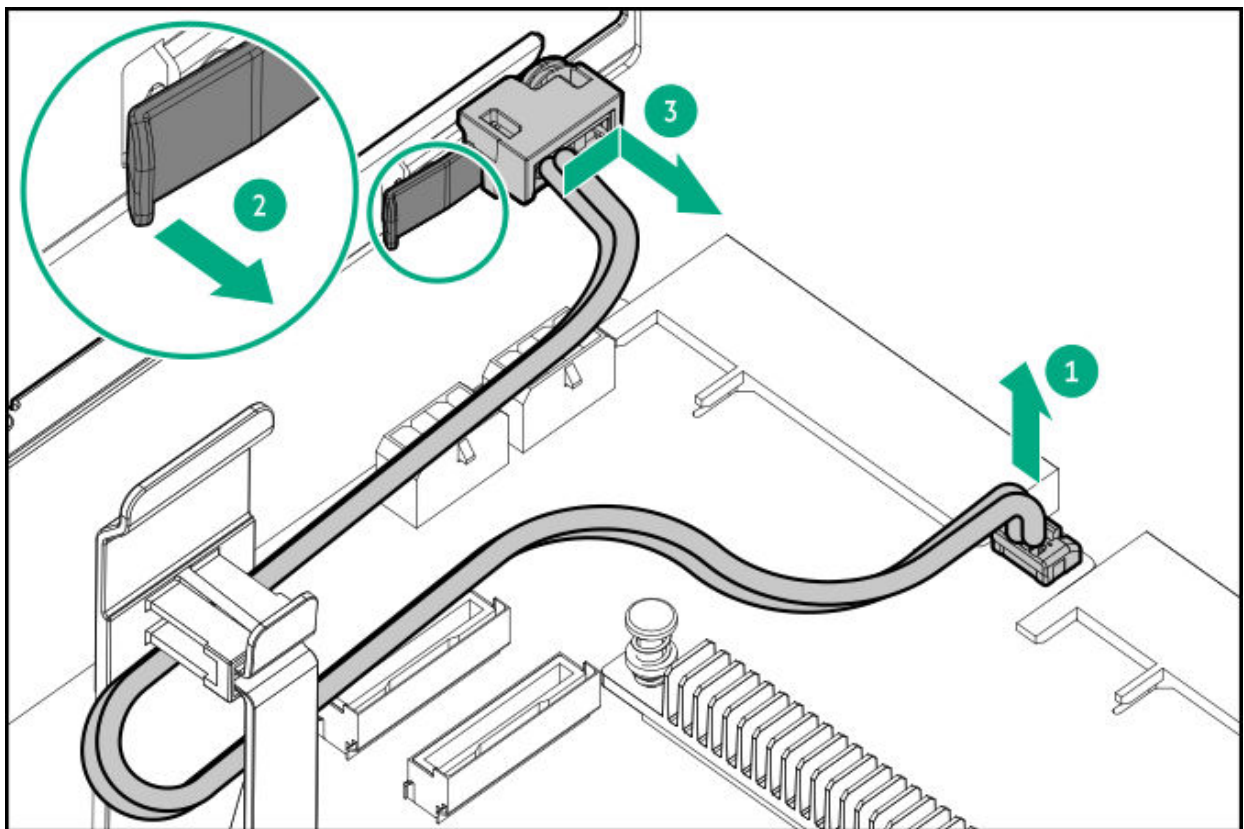

Results

The removal procedure is complete. To replace the component, reverse this procedure.

Removing and replacing a cable clamp

About this task

Procedure

1. Power down the server.
2. Remove all power:
 - a. Disconnect each power cord from the power source.
 - b. Disconnect each power cord from the server.
3. Disconnect all peripheral cables from the server.
4. If the server is in tower mode, place the server on a flat, level surface with the access panel facing up.
5. If the server is in rack mode, do one of the following:
 - Extend the server from the rack.
 - Remove the server from the rack.
6. Unlock the front bezel.
7. Remove the access panel.
8. Open the cable clamp.
9. Release all cables from the clamp.
10. Remove the cable clamp:
 - a. Press and hold the latch.
 - b. Slide the clamp up to remove it from the chassis.

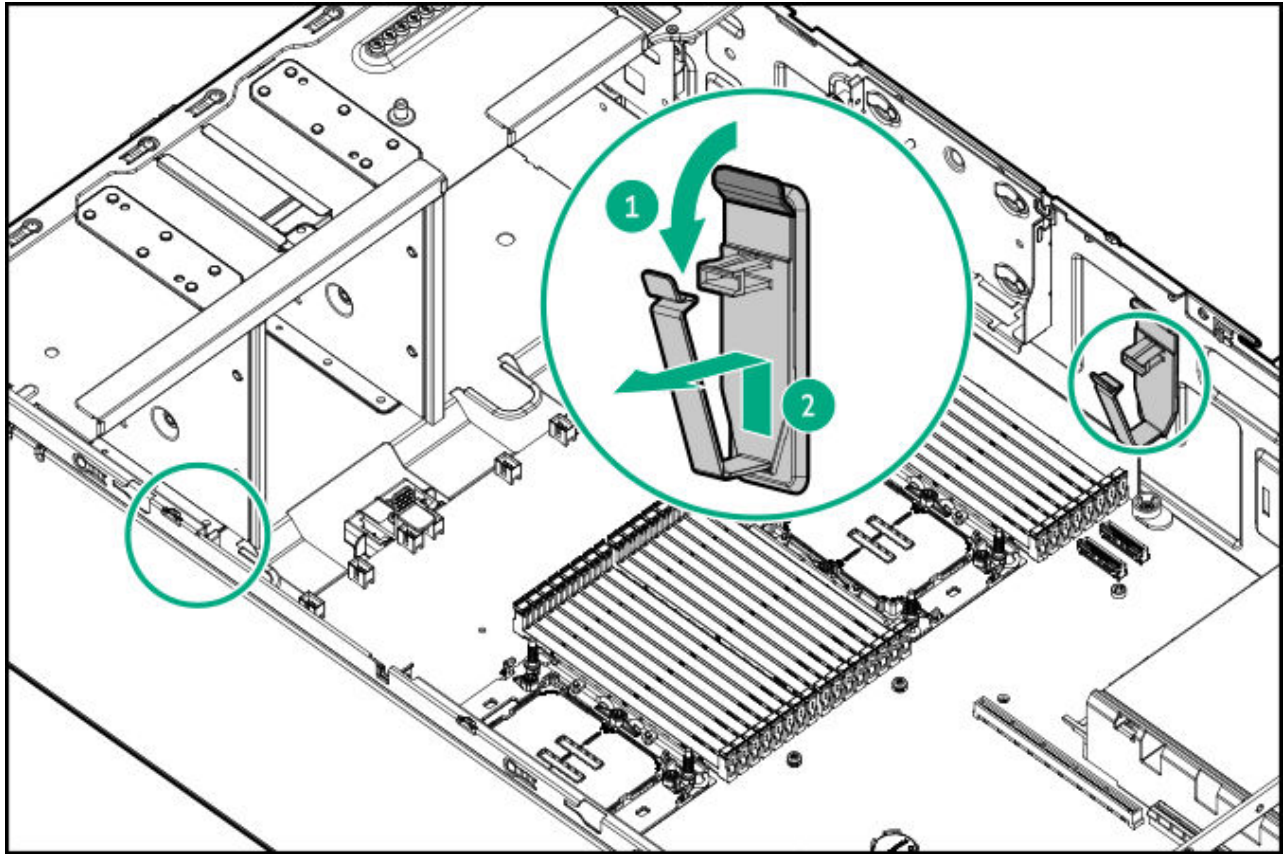

Results

The removal procedure is complete. To replace the component, reverse this procedure.

HPE NS204i-u Boot Device V2 replacement

Subtopics

[Removing and replacing a boot device drive](#)

[Removing and replacing the boot device V2 cage on the front panel](#)

[Removing and replacing the boot device V2 cage on the rear panel](#)

Removing and replacing a boot device drive

Prerequisites

- Identify the failed drive, do one of the following:

- [Locate the boot device drive with a flashing amber or blue Online/Activity LED.](#)
 - iLO web interface: **Storage** page
 - UEFI System Utilities: **System Utilities** > **Embedded Applications** > **Integrated Management Log** > **View IML**
- Before you perform this procedure, make sure that you have a Phillips No. 1 screwdriver available.

About this task

https://sketchfab.com/models/bbb61184a86a4ca792b988e9caae5278/embed?ui_infos=0&ui_watermark=0&ui_help=0&ui_vr=0&ui_settings=0&ui_inspector=0&ui_hint=2&ui_color=01a982&ui_theme=dark&autostart=1&camera=0&



CAUTION

Before replacing a DIMM, backplane, expansion card, riser board, or other similar PCA components due to a perceived hardware error, make sure first that the component is firmly seated in the slot.

When installing the replacement component:

- Observe [antistatic precautions](#).
- Handle the PCA only along the edges.
- Do not touch the components and connectors on the PCA.
- Do not bend or flex the PCA.



IMPORTANT

For successful RAID 1 configuration, verify that the boot device SSDs have the same model number and firmware version:

- In the iLO web interface, see the **Storage** page.
- In UEFI System Utilities, see **System Configuration** > **HPE NS204i Boot Controller** > **Physical Device Information**.

Configurations with SSDs from different manufacturers are not supported.

Procedure

1. [Back up all server data.](#)
2. Remove the failed drive and replace it with a new drive:

- a. Press and hold the carrier latch.
- b. Pivot the latch to open.
- c. Slide the carrier out from the boot device cage.

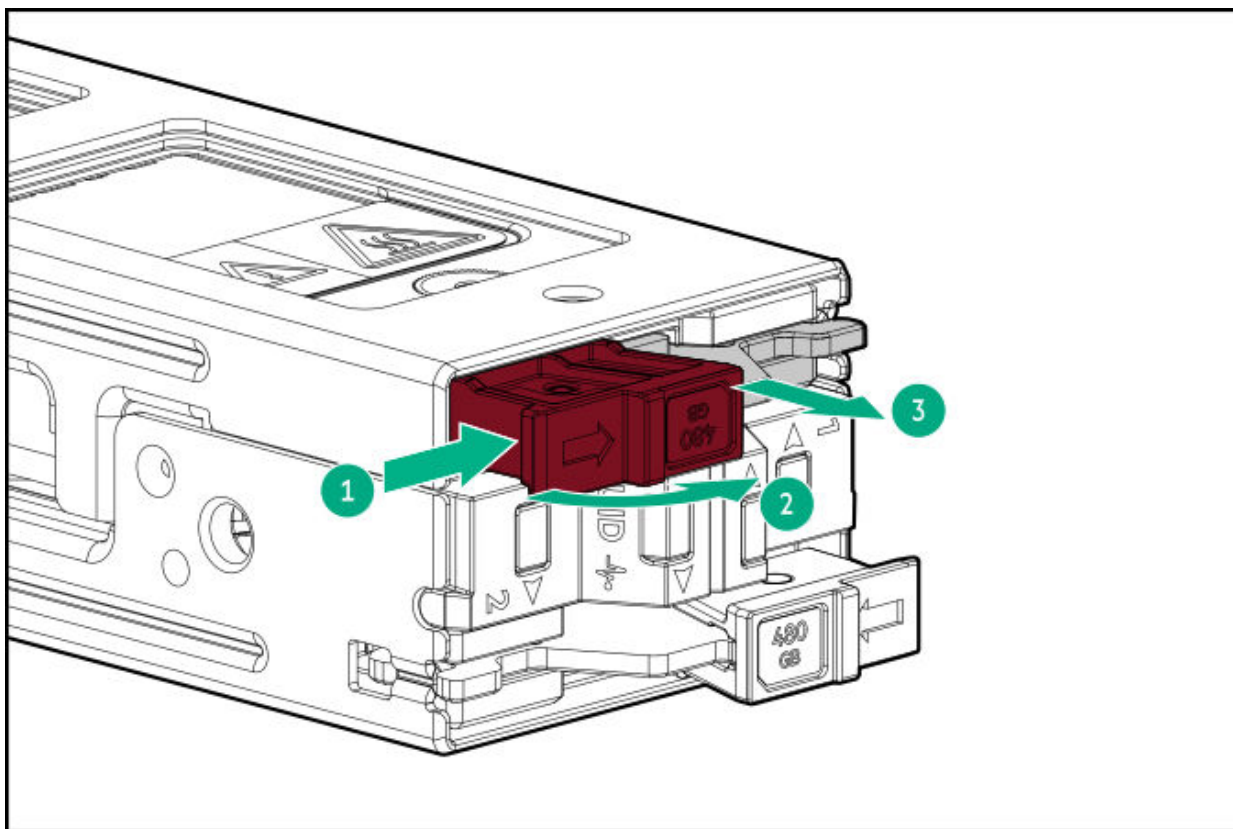

- d. Remove the SSD mounting screw.
- e. Tilt the SSD at a 45° angle, and then remove the failed SSD from the M.2 slot.

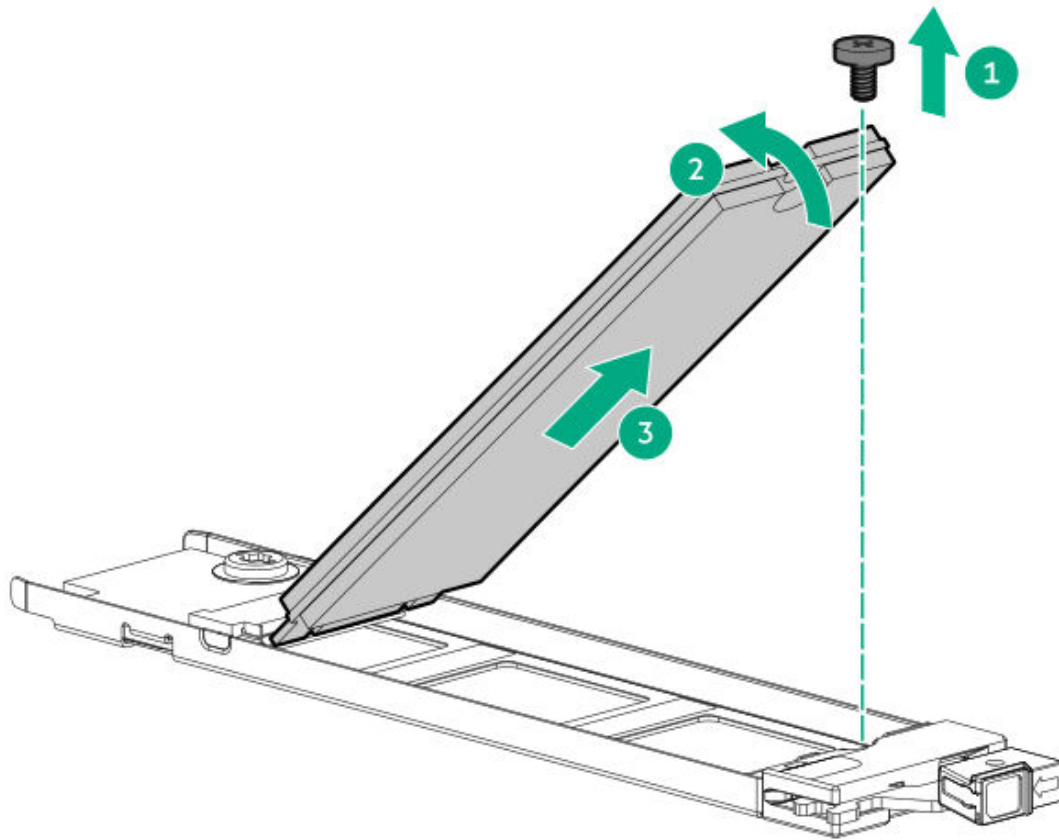

- f. Insert the new SSD into the M.2 slot at a 45° angle.
- g. Carefully press the SSD down to the horizontal position.
- h. Install the SSD mounting screw.

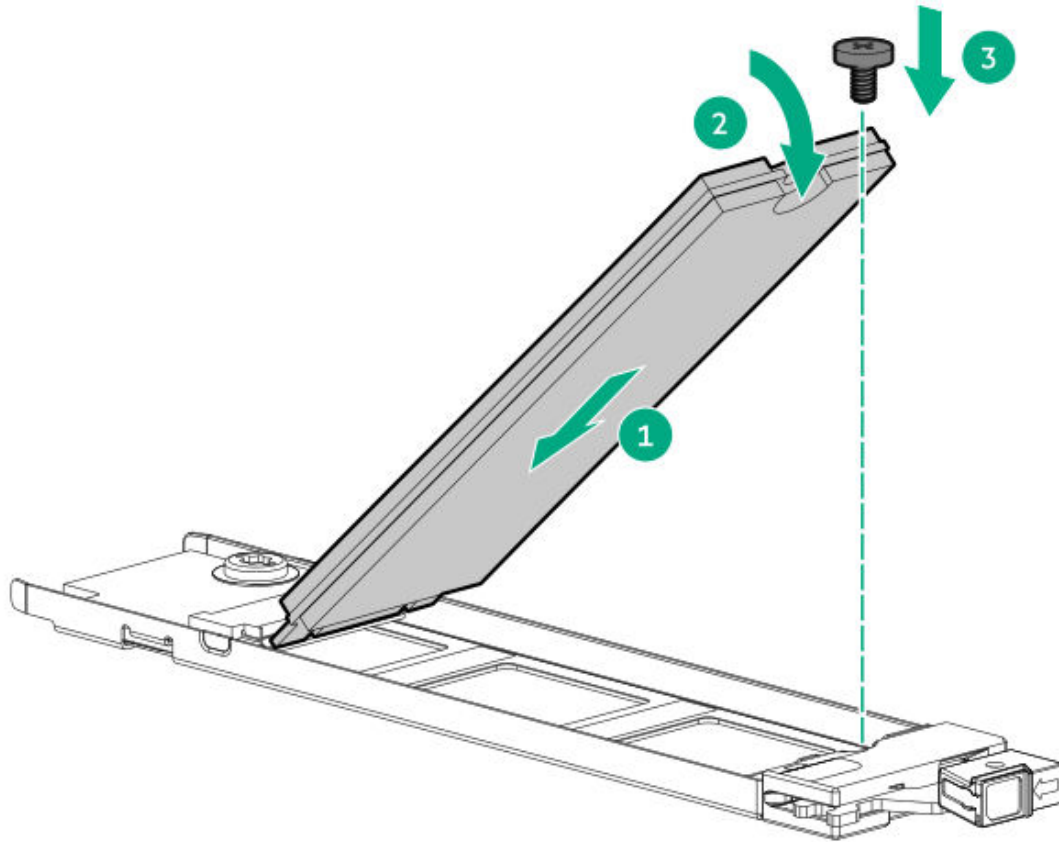

- i. If closed, pivot the carrier latch to open.
- j. Slide the carrier with the new SSD into the boot device cage.
- k. Pivot the latch to close.

Make sure that the carrier latch is locked on the boot device cage.

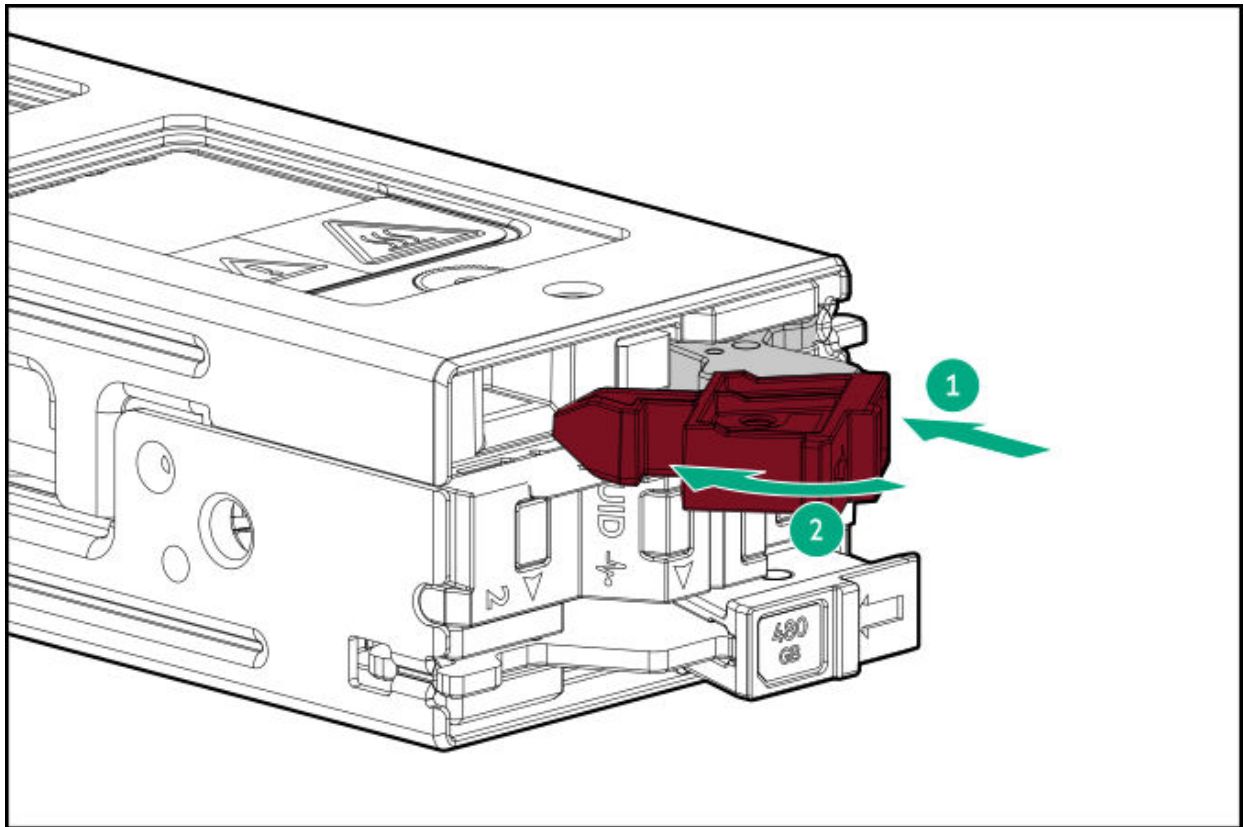

The boot device automatically rebuilds the RAID 1 volume.

3. If the newly installed SSD has a different model number as the SSD on the other drive carrier, replace the other SSD with one that is of the same model number as the new SSD.

Once both SSDs are installed, the boot device automatically rebuilds the RAID 1 volume.

4. To monitor the drive rebuild status, see any of the following:

- [Boot device Online/Activity LED](#)
- iLO web interface: **Storage** page
- UEFI System Utilities:
 - **System Utilities > System Configuration > Virtual Device Information > NS Volume > Virtual Device Detail Information**
 - **System Utilities > Embedded Applications > Integrated Management Log > View IML**

Removing and replacing the boot device V2 cage on the front panel

Prerequisites

Before you perform this procedure, make sure that you have a T-15 Torx screwdriver available.

About this task

https://sketchfab.com/models/81c09e74b8f4419c9ce69128f9c6e778/embed?ui_infos=0&ui_watermark=0&ui_help=0&ui_vr=0&ui_settings=0&ui_inspector=0&ui_hint=2&ui_color=01a982&ui_theme=dark&autostart=1&camera=0&



CAUTION

A discharge of static electricity from a finger or other conductor might damage system boards or other static-sensitive devices. To prevent damage, observe [antistatic precautions](#).



CAUTION

To prevent improper cooling and thermal damage, do not operate the server unless all bays are populated with either a component or a blank.



IMPORTANT

For successful RAID 1 configuration, verify that the boot device SSDs have the same model number and firmware version:

- In the iLO web interface, see the **Storage** page.
- In UEFI System Utilities, see **System Configuration > HPE NS204i Boot Controller > Physical Device Information**.

Configurations with SSDs from different manufacturers are not supported.

Procedure

1. [Remove the front bezel](#).
2. [Power down the server](#).
3. Remove all power:
 - a. Disconnect each power cord from the power source.
 - b. Disconnect each power cord from the server.
4. Disconnect all peripheral cables from the server.

5. If the server is in tower mode, place the server on a flat, level surface with the access panel facing up.
6. If the server is in rack mode, do one of the following:
 - Extend the server from the rack.
 - Remove the server from the rack.
7. Remove the access panel.
8. Remove the fan cage.
9. If installed, remove the drive cage from box 1.
0. Remove the boot device cage from the front panel.

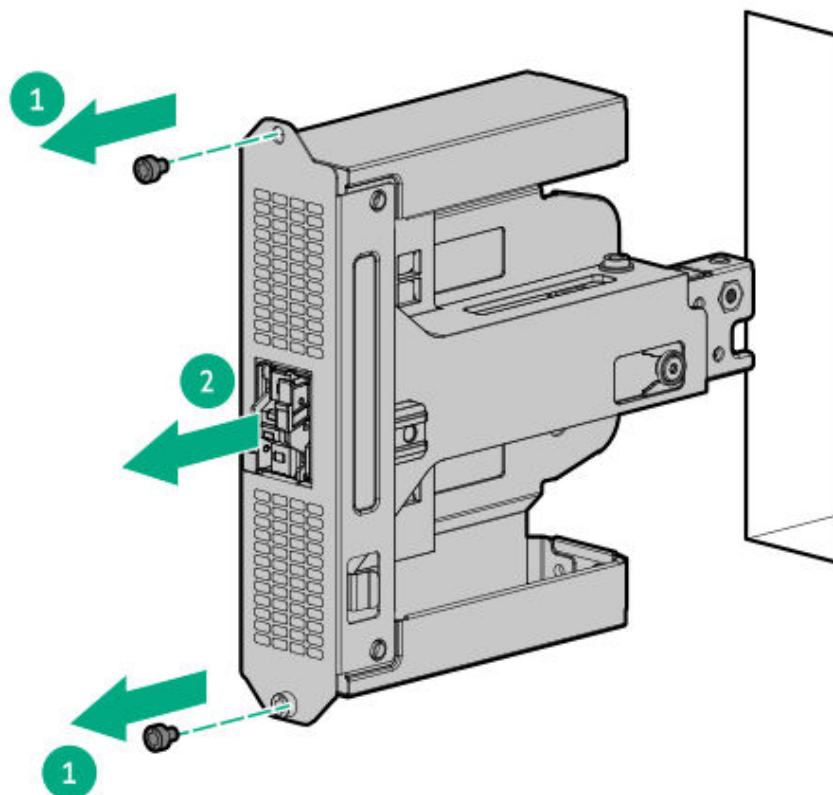

- .1. Disconnect the signal and power cables from the boot device.
- .2. Remove the boot device baffle from the cage.

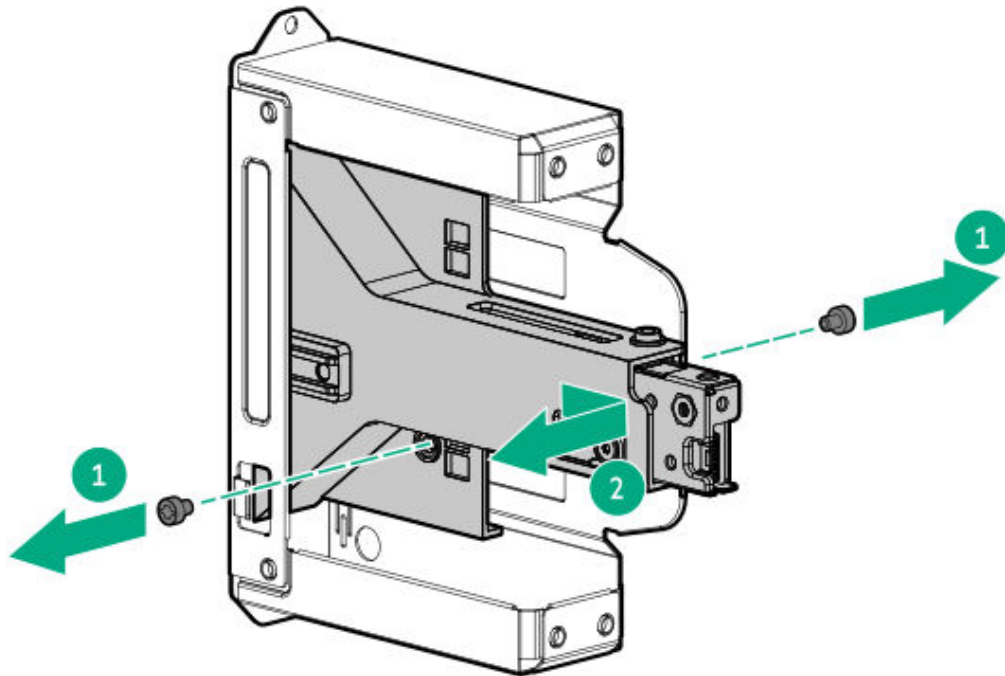

3. Remove the boot device baffle.

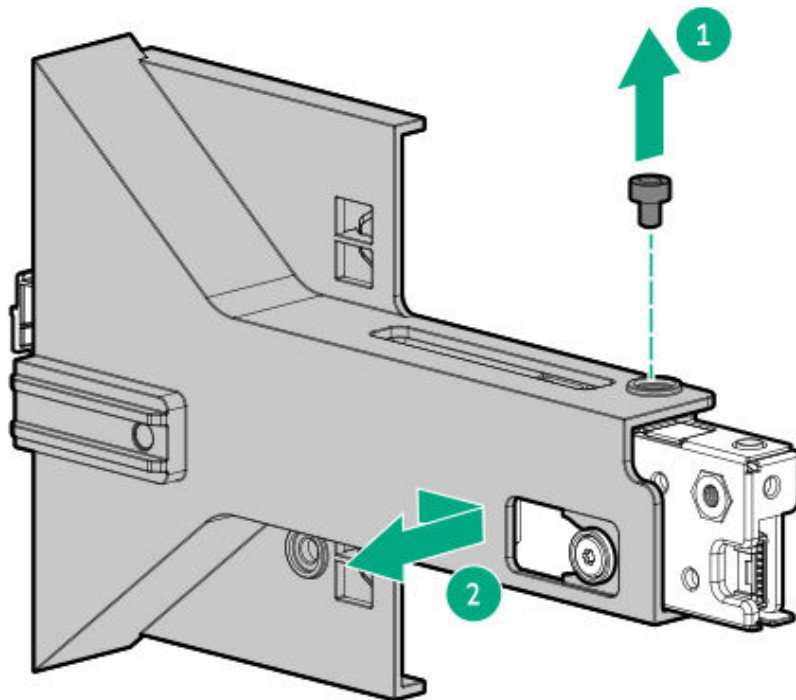

4. Remove the boot device carriers:
 - a. Press and hold the carrier latch.
 - b. Pivot the latch to open.
 - c. Slide the carrier out from the boot device cage.

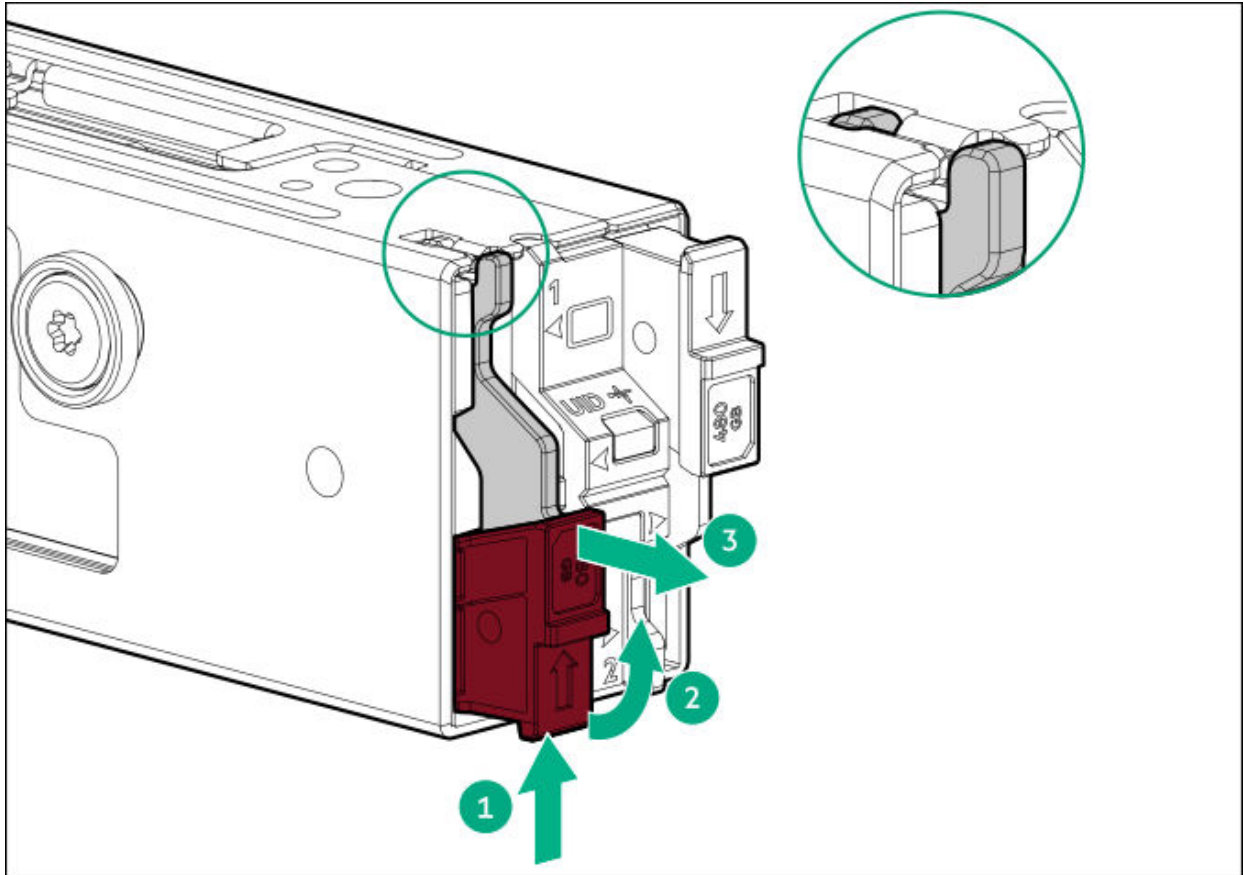

Results

The removal procedure is complete. To replace the component, reverse this procedure.

Removing and replacing the boot device V2 cage on the rear panel

Prerequisites

Before you perform this procedure, make sure that you have a T-15 Torx screwdriver available.

About this task

https://sketchfab.com/models/ae39752a1ff74805b80ea84539ab7da5/embed?ui_infos=0&ui_watermark=0&ui_help=0&ui_vr=0&ui_settings=0&ui_inspector=0&ui_hint=2&ui_color=01a982&ui_theme=dark&autostart=1&camera=0&



CAUTION

A discharge of static electricity from a finger or other conductor might damage system boards or other static-sensitive devices. To prevent damage, observe [antistatic precautions](#).



CAUTION

To prevent improper cooling and thermal damage, do not operate the server unless all bays are populated with either a component or a blank.



IMPORTANT

For successful RAID 1 configuration, verify that the boot device SSDs have the same model number and firmware version:

- In the iLO web interface, see the **Storage** page.
- In UEFI System Utilities, see **System Configuration > HPE NS204i Boot Controller > Physical Device Information**.

Configurations with SSDs from different manufacturers are not supported.

Procedure

1. [Power down the server](#).
2. Remove all power:
 - a. Disconnect each power cord from the power source.
 - b. Disconnect each power cord from the server.
3. Disconnect all peripheral cables from the server.
4. If the server is in tower mode, [place the server on a flat, level surface with the access panel facing up](#).
5. If the server is in rack mode, do one of the following, [remove the server from the rack](#)
6. Unlock the front bezel.
7. [Remove the access panel](#).

8. Remove the boot device from the top of the power supply cage:
 - a. Pull and hold the latch.
 - b. Remove the boot device from the chassis side wall.

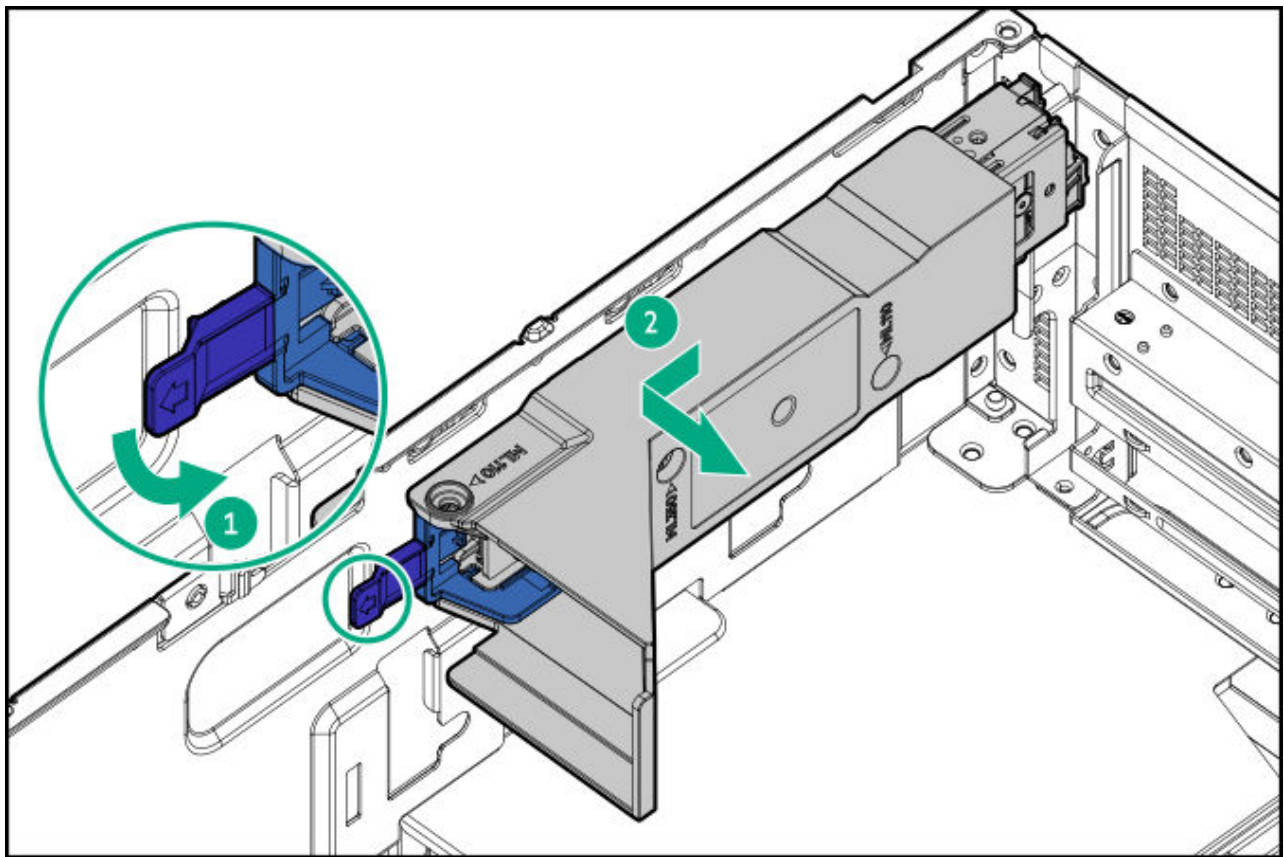

9. Disconnect the signal and power cables from the boot device.
10. Remove the boot device baffle:
 - a. Remove the boot device baffle screws.
 - b. Remove the baffle from the boot device.

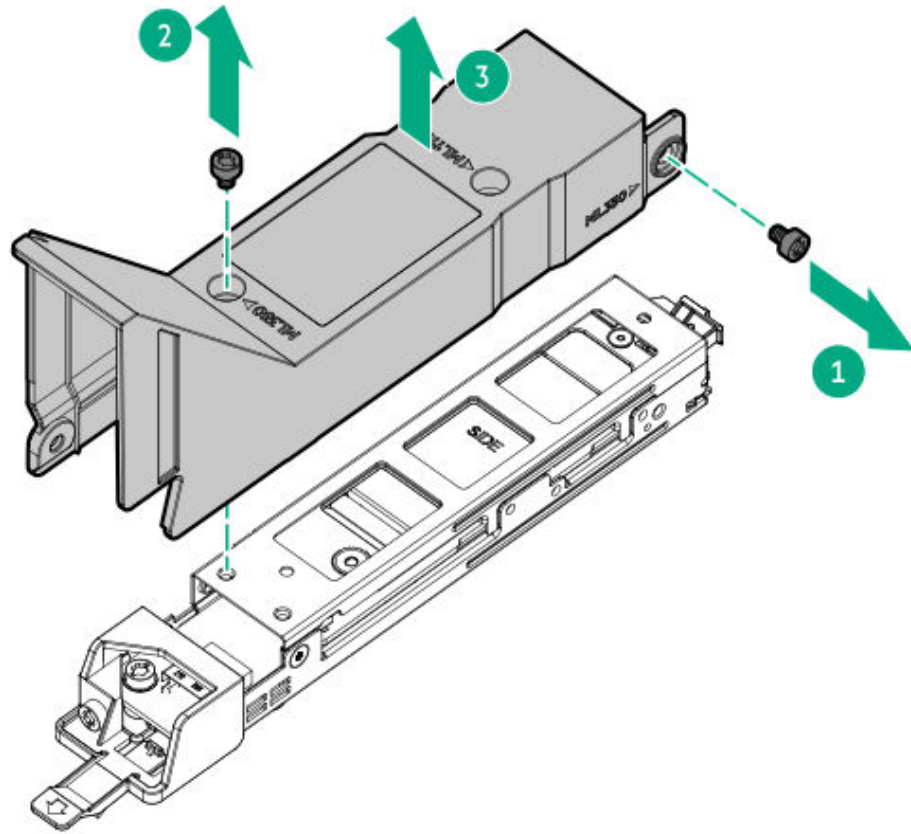

- .1. Remove the boot device latch:
 - a. Remove the latch screw.
 - b. Remove the latch from the boot device.

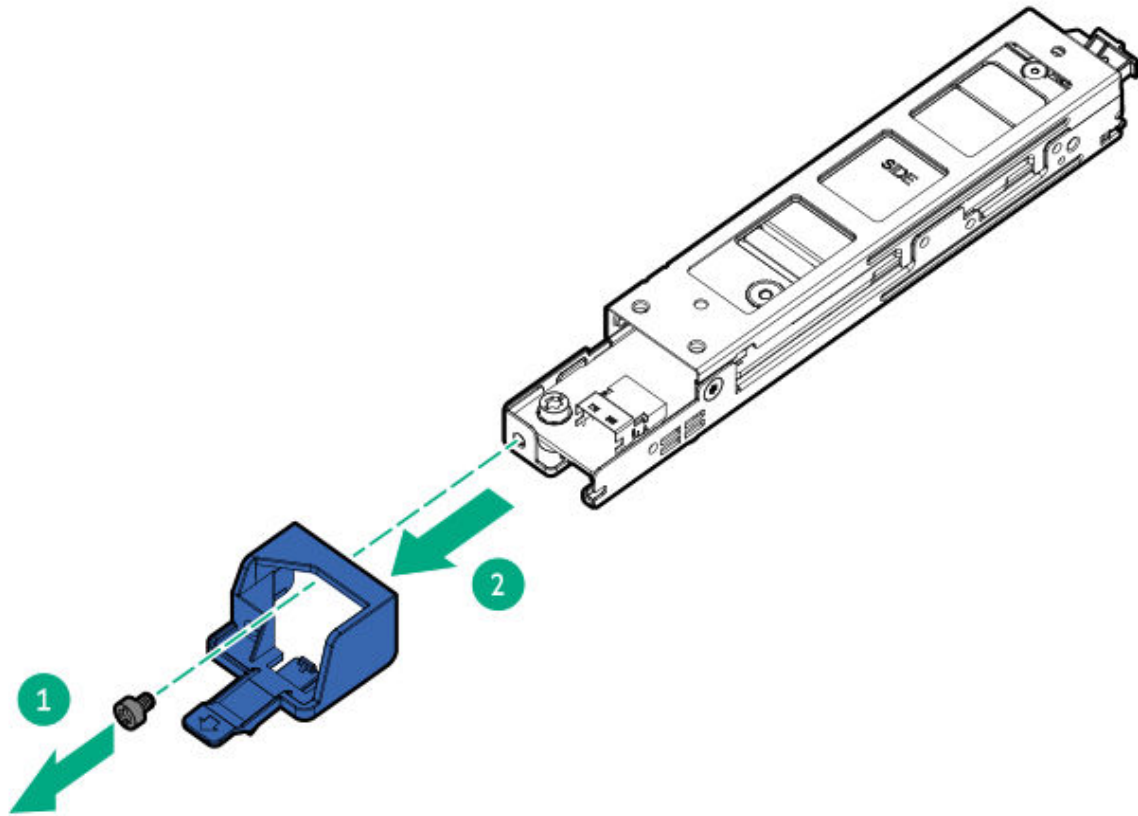

.2. Remove the boot device carriers:

- a. Press and hold the carrier latch.
- b. Pivot the latch to open.
- c. Slide the carrier out from the boot device cage.

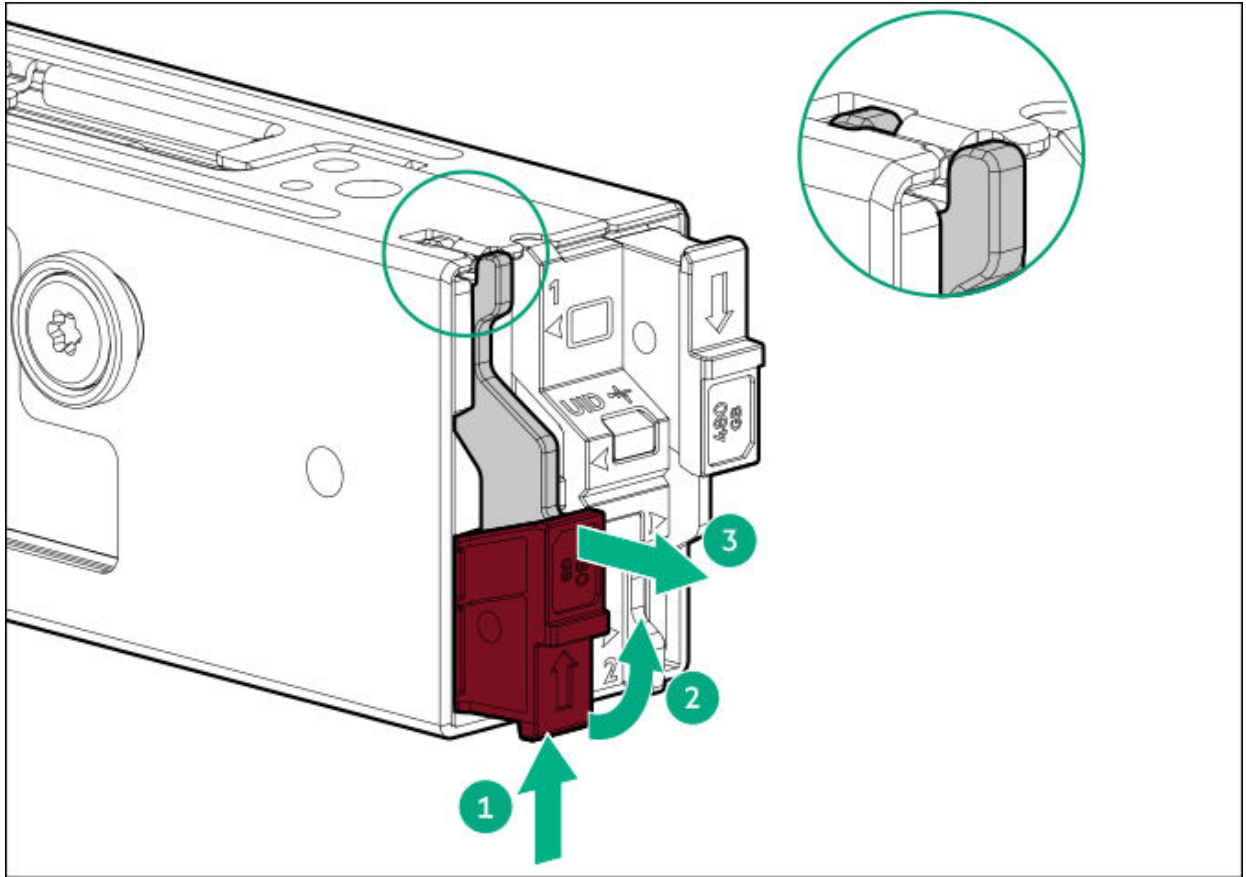

Results

The removal procedure is complete. To replace the component, reverse this procedure.

Removing and replacing the front boot device cage assembly

Prerequisites

Before you perform this procedure, make sure that you have a T-15 Torx screwdriver available.

About this task

<https://sketchfab.com/models/81c09e74b8f4419c9ce69128f9c6e778/embed?>



CAUTION

A discharge of static electricity from a finger or other conductor might damage system boards or other static-sensitive devices. To prevent damage, observe [antistatic precautions](#).

Procedure

1. [Remove the front bezel](#).
2. [Power down the server](#).
3. Remove all power:
 - a. Disconnect each power cord from the power source.
 - b. Disconnect each power cord from the server.
4. Disconnect all peripheral cables from the server.
5. If the server is in tower mode, [place the server on a flat, level surface with the access panel facing up](#).
6. If the server is in rack mode, do one of the following:
 - [Extend the server from the rack](#).
 - [Remove the server from the rack](#).
7. [Remove the access panel](#).
8. [Remove the fan cage](#).
9. If installed, [remove the drive cage from box 1](#).
10. Remove the boot device cage from the front panel.

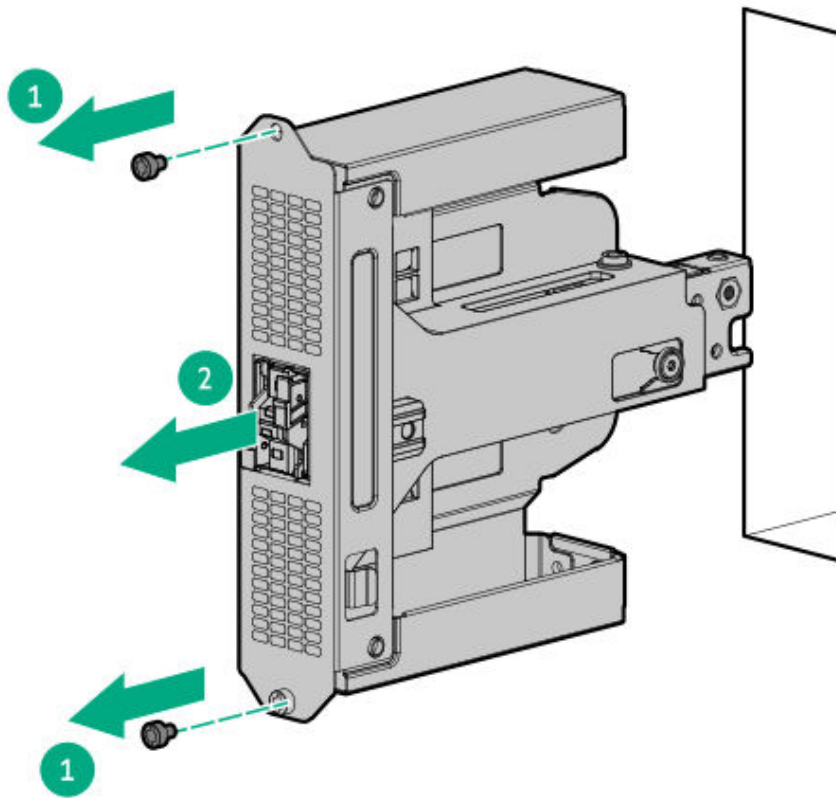

- .1. Disconnect the signal and power cables from the boot device.
- .2. Remove the boot device baffle from the cage.

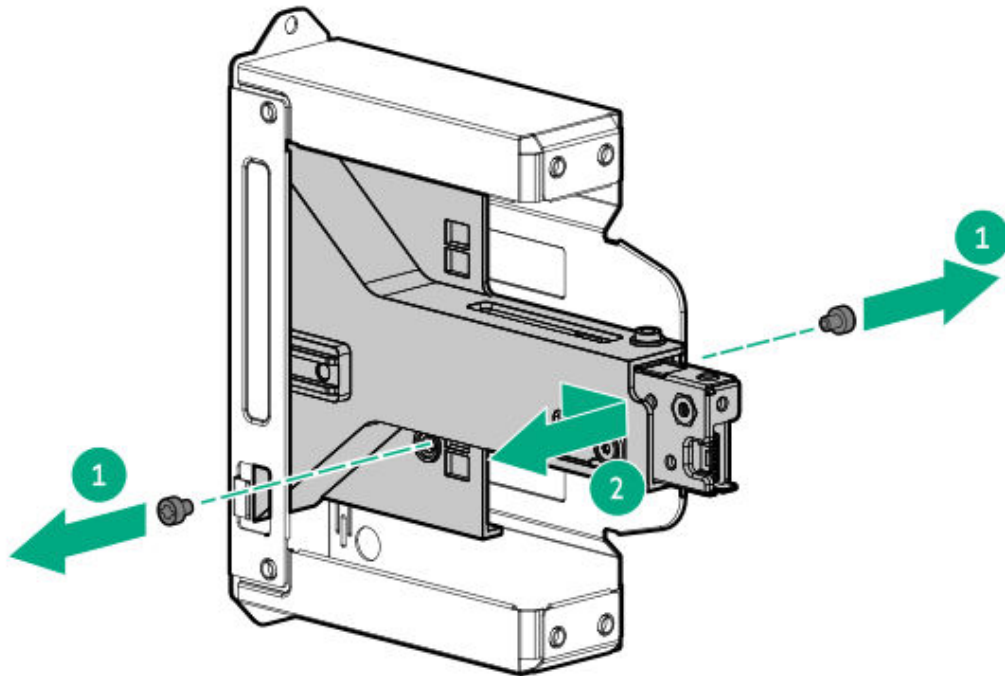

3. Remove the boot device baffle.

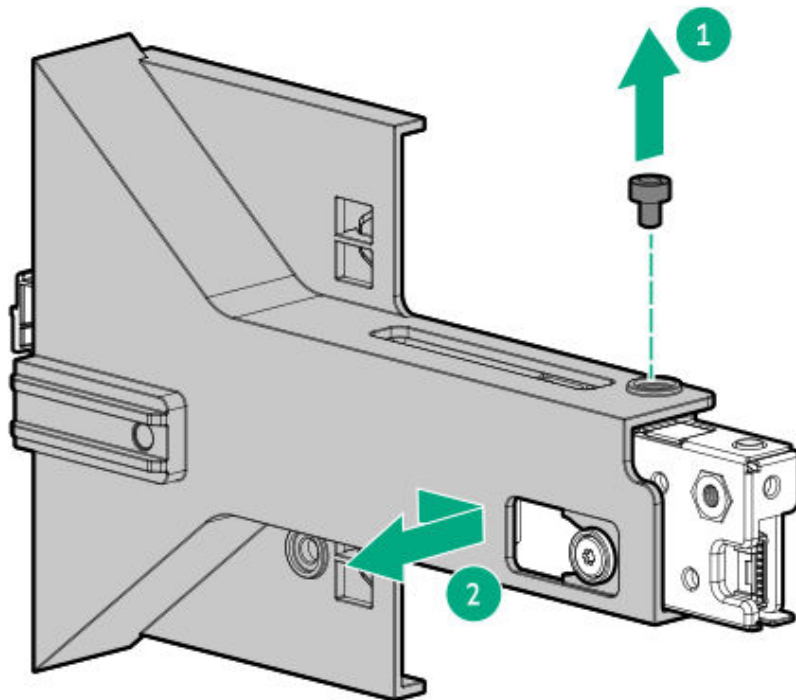

Results

The removal procedure is complete. To replace the component, reverse this procedure.

Removing and replacing the boot device baffle

Prerequisites

Before you perform this procedure, make sure that you have a T-15 Torx screwdriver available.

About this task

https://sketchfab.com/models/90cc010de7794bbe97e597d173ef7f04/embed?ui_infos=0&ui_watermark=0&ui_help=0&ui_vr=0&ui_settings=0&ui_inspector=0&ui_hint=2&ui_color=01a982&ui_theme=dark&autostart=1&camera=0&



CAUTION

A discharge of static electricity from a finger or other conductor might damage system boards or other static-sensitive devices. To prevent damage, observe antistatic precautions.

Procedure

1. Power down the server.
2. Remove all power:
 - a. Disconnect each power cord from the power source.
 - b. Disconnect each power cord from the server.
3. Disconnect all peripheral cables from the server.
4. If the server is in tower mode, place the server on a flat, level surface with the access panel facing up.
5. If the server is in rack mode, do one of the following, remove the server from the rack.
6. Unlock the front bezel.
7. Remove the access panel.
8. Remove the boot device from the top of the power supply cage:
 - a. Pull and hold the latch.

- b. Remove the boot device from the chassis side wall.

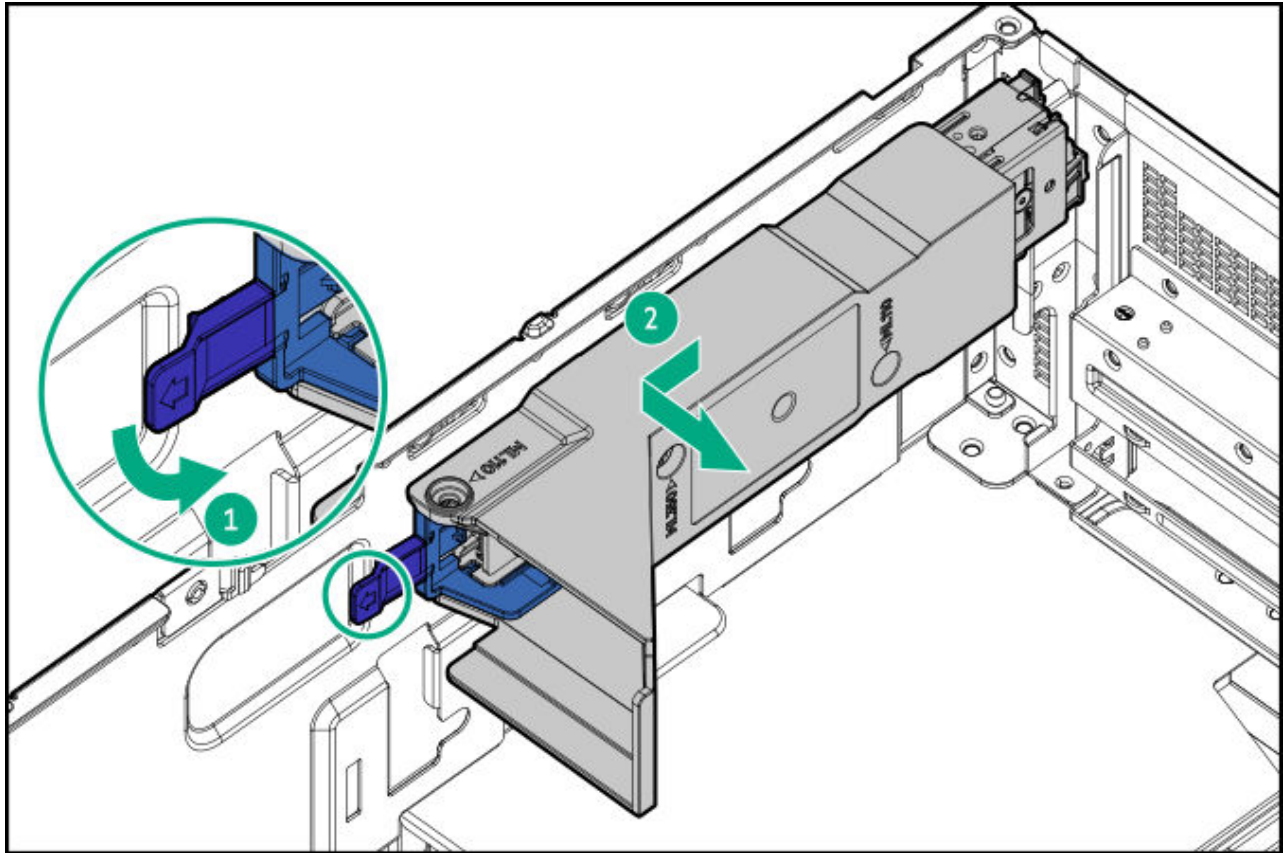

9. Remove the boot device baffle:
 - a. Remove the boot device baffle screws.
 - b. Remove the baffle from the boot device.

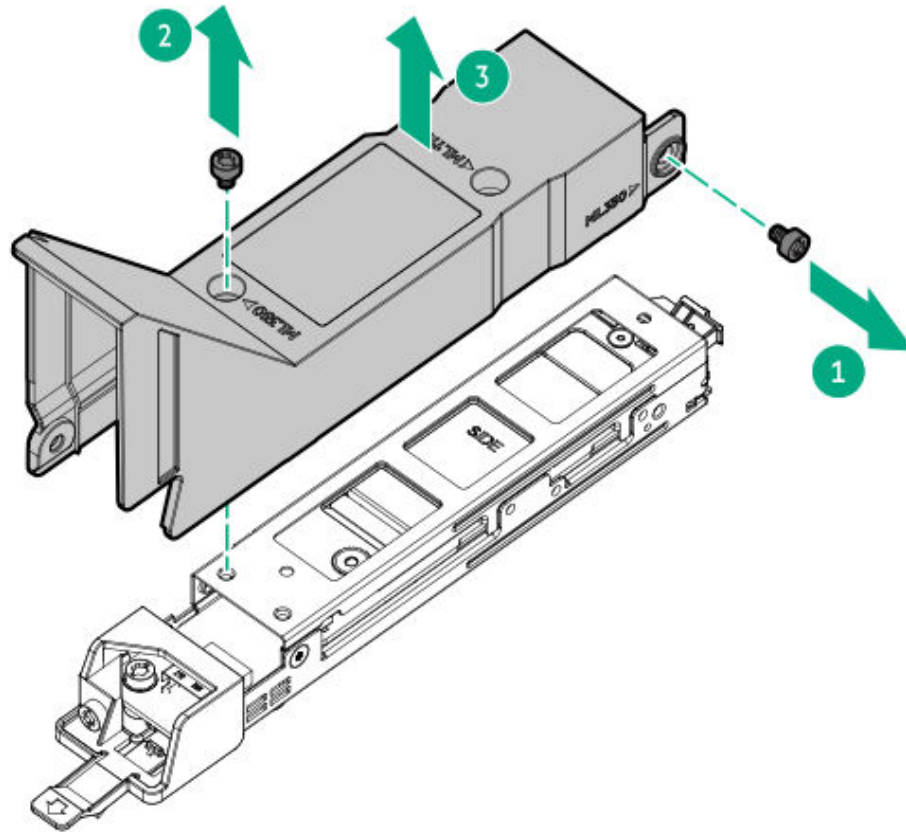

Results

The removal procedure is complete. To replace the component, reverse this procedure.

Removing and replacing the boot device latch

Prerequisites

Before you perform this procedure, make sure that you have a T-15 Torx screwdriver available.

About this task

<https://sketchfab.com/models/840dc492de9541b7aaca43c636d48e39/embed?>



CAUTION

A discharge of static electricity from a finger or other conductor might damage system boards or other static-sensitive devices. To prevent damage, observe [antistatic precautions](#).

Procedure

1. [Power down the server](#).
2. Remove all power:
 - a. Disconnect each power cord from the power source.
 - b. Disconnect each power cord from the server.
3. Disconnect all peripheral cables from the server.
4. If the server is in tower mode, [place the server on a flat, level surface with the access panel facing up](#).
5. If the server is in rack mode, do one of the following:
 - [Extend the server from the rack](#).
 - [Remove the server from the rack](#).
6. Unlock the front bezel.
7. [Remove the access panel](#).
8. Remove the boot device from the top of the power supply cage:
 - a. Pull and hold the latch.
 - b. Remove the boot device from the chassis side wall.

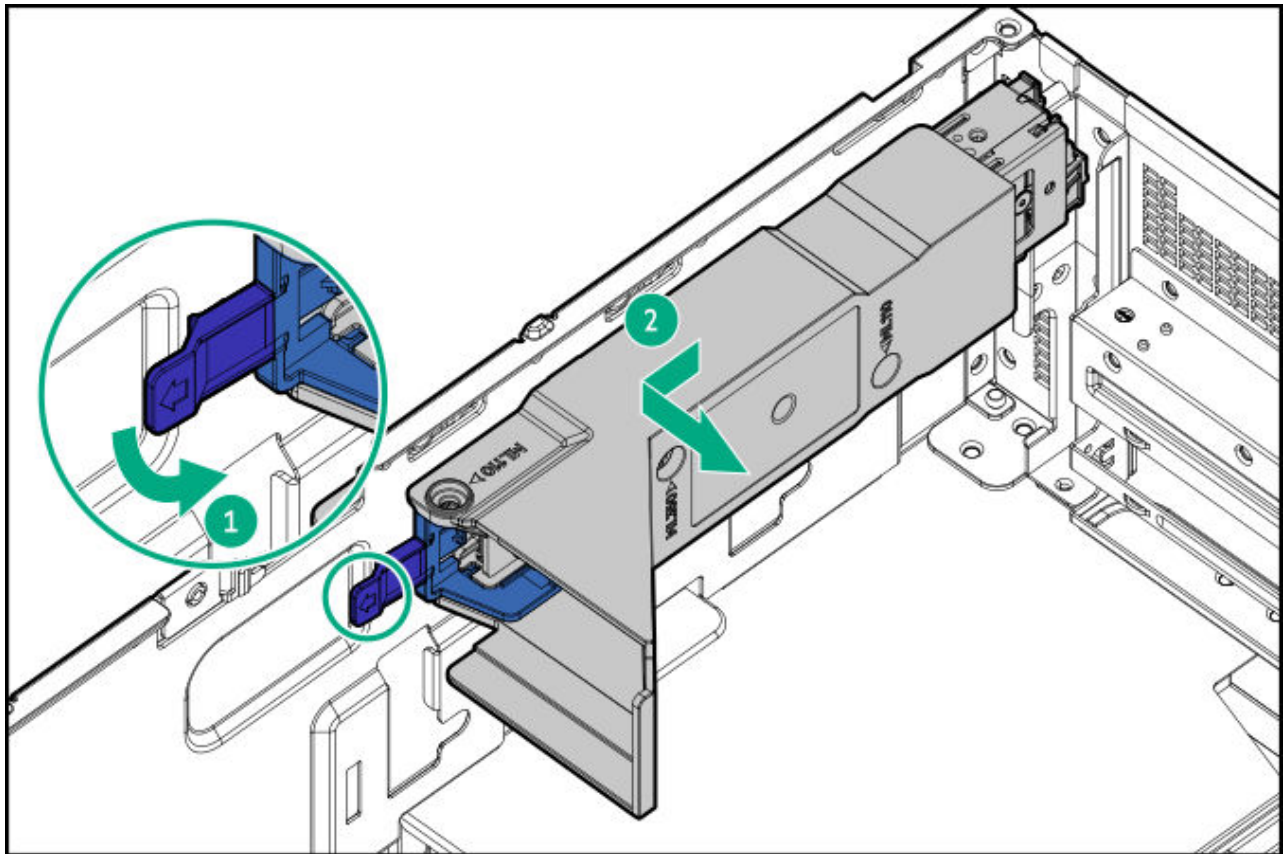

9. Disconnect the signal and power cables from the boot device.
10. Remove the boot device baffle:
 - a. Remove the boot device baffle screws.
 - b. Remove the baffle from the boot device.

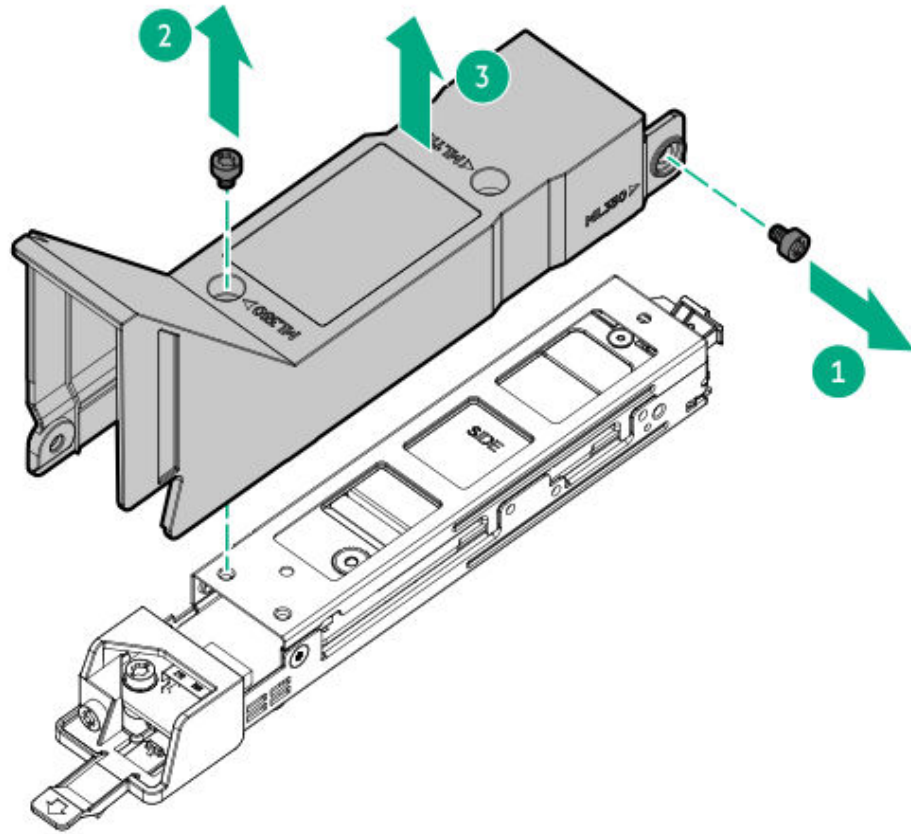

- .1. Remove the boot device latch:
 - a. Remove the latch screw.
 - b. Remove the latch from the boot device.

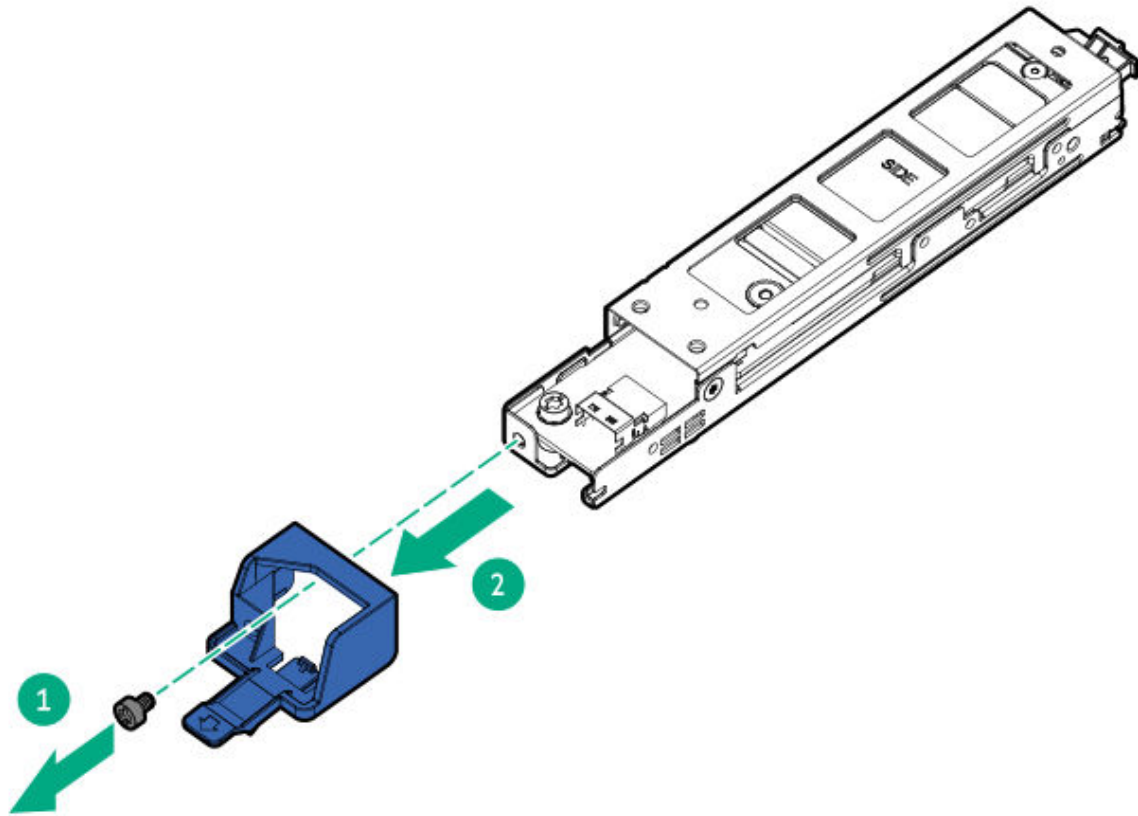

Results

The removal procedure is complete. To replace the component, reverse this procedure.

Removing and replacing the boot device blank

Prerequisites

Before you perform this procedure, make sure that you have a T-10 Torx screwdriver available.

Procedure

1. Power down the server.
2. Remove all power:
 - a. Disconnect each power cord from the power source.
 - b. Disconnect each power cord from the server.
3. Disconnect all peripheral cables from the server.

4. If the server is in tower mode, place the server on a flat, level surface with the access panel facing up.
5. If the server is in rack mode, remove the server from the rack.
6. Unlock the front bezel.
7. Remove the access panel.
8. Remove the boot device blank.

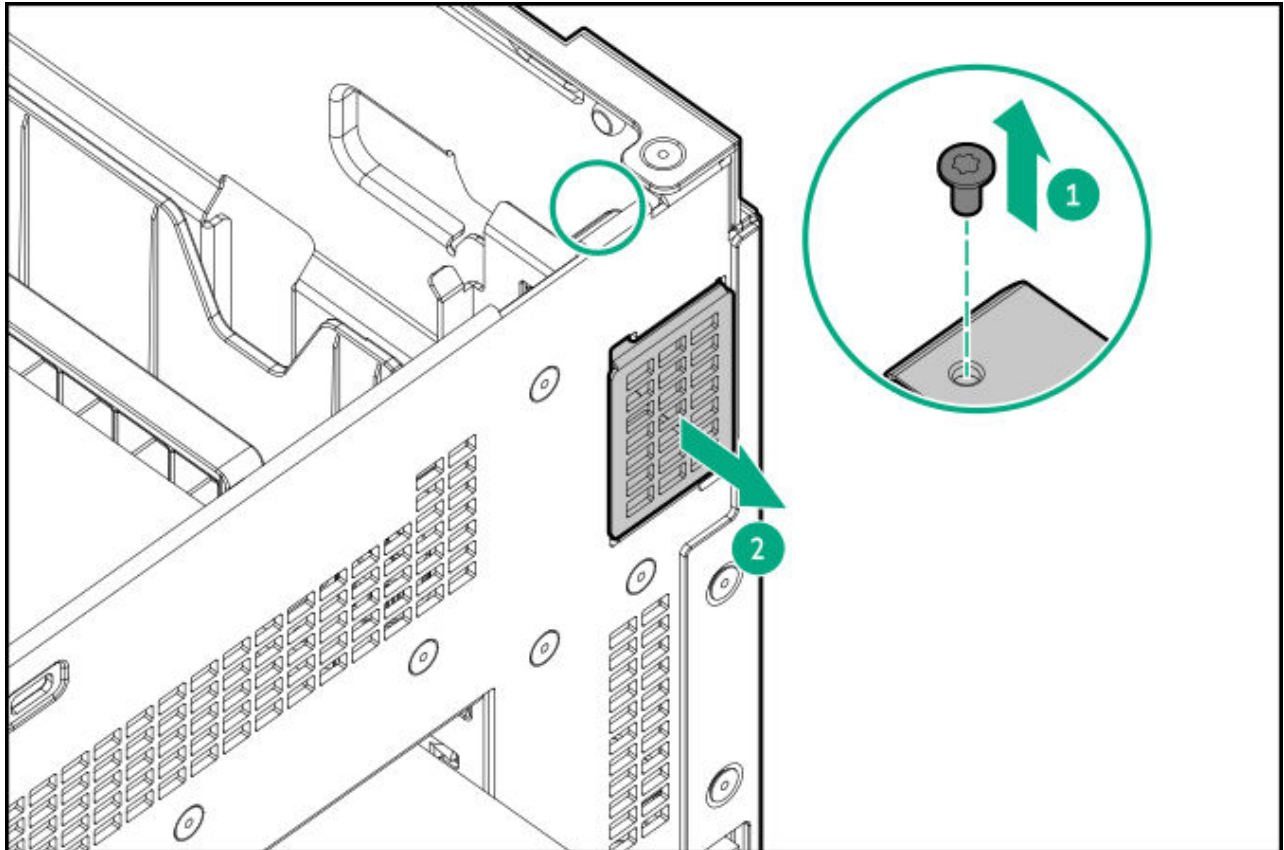

Results

The removal procedure is complete. To replace the component, reverse this procedure.

Removing and replacing the energy pack

About this task

<https://sketchfab.com/models/3a44b0ebfff6432188c8438871f0ff06/embed?>



CAUTION

A discharge of static electricity from a finger or other conductor might damage system boards or other static-sensitive devices. To prevent damage, observe [antistatic precautions](#).

Procedure

1. [Power down the server](#).
2. Remove all power:
 - a. Disconnect each power cord from the power source.
 - b. Disconnect each power cord from the server.
3. Disconnect all peripheral cables from the server.
4. If the server is in tower mode, [place the server on a flat, level surface with the access panel facing up](#).
5. If the server is in rack mode, [remove the server from the rack](#).
6. Unlock the front bezel.
7. [Remove the access panel](#).
8. If installed, [remove the boot device](#).
9. [Disconnect the energy pack extension cable from the system board](#).
10. Remove the energy pack:
 - a. Press and hold the release latch.
 - b. Lift one end of the energy pack and release it from the holder.

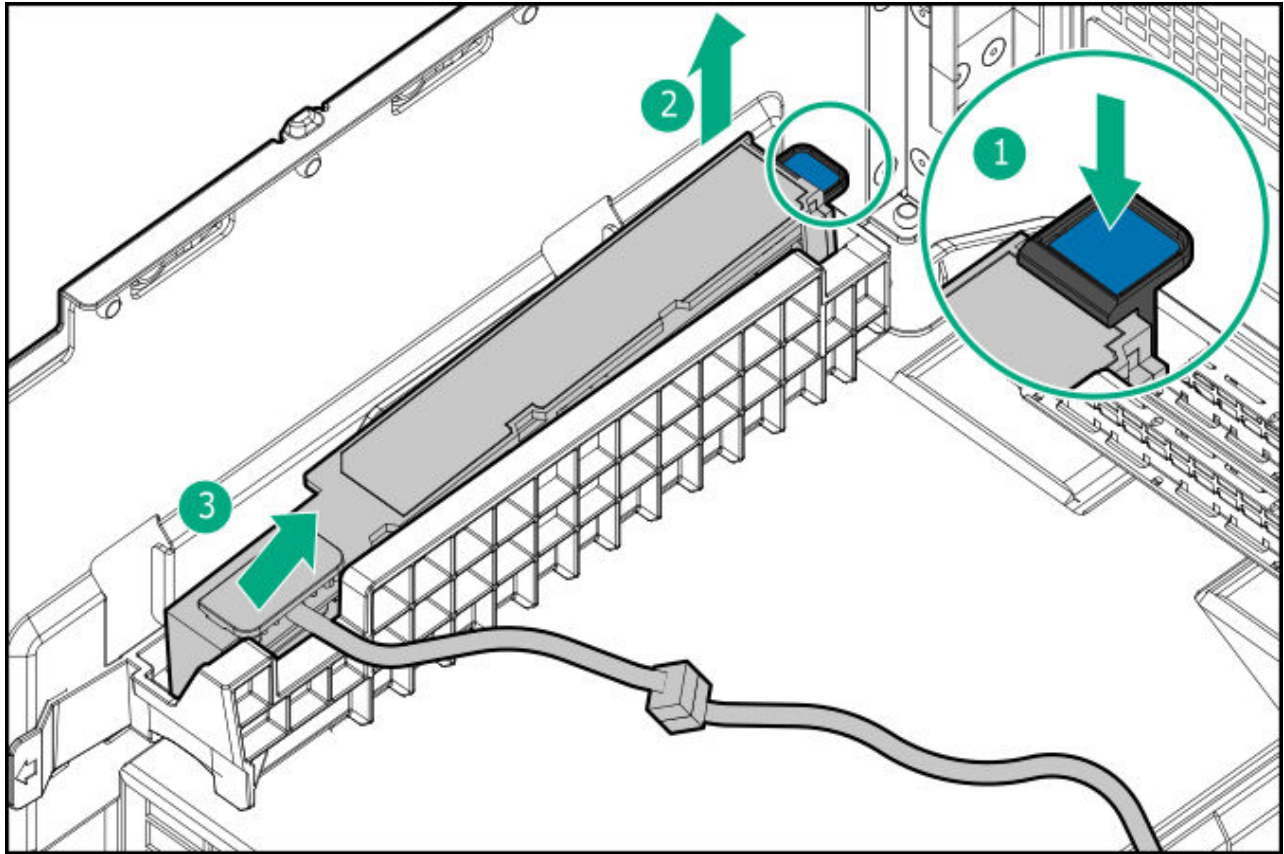

1. Disconnect the energy pack extension cable from the energy pack cable.

Results

The removal procedure is complete. To replace the component, reverse this procedure.

Removing and replacing the energy pack holder

About this task

Procedure

1. Power down the server.
2. Remove all power:
 - a. Disconnect each power cord from the power source.
 - b. Disconnect each power cord from the server.
3. Disconnect all peripheral cables from the server.

4. If the server is in tower mode, place the server on a flat, level surface with the access panel facing up.
5. If the server is in rack mode, do one of the following:
 - Extend the server from the rack.
 - Remove the server from the rack.
6. Unlock the front bezel.
7. Remove the access panel.
8. If installed, remove the following:
 - a. Remove the boot device.
 - b. Remove the energy pack.
9. Remove the energy pack holder.

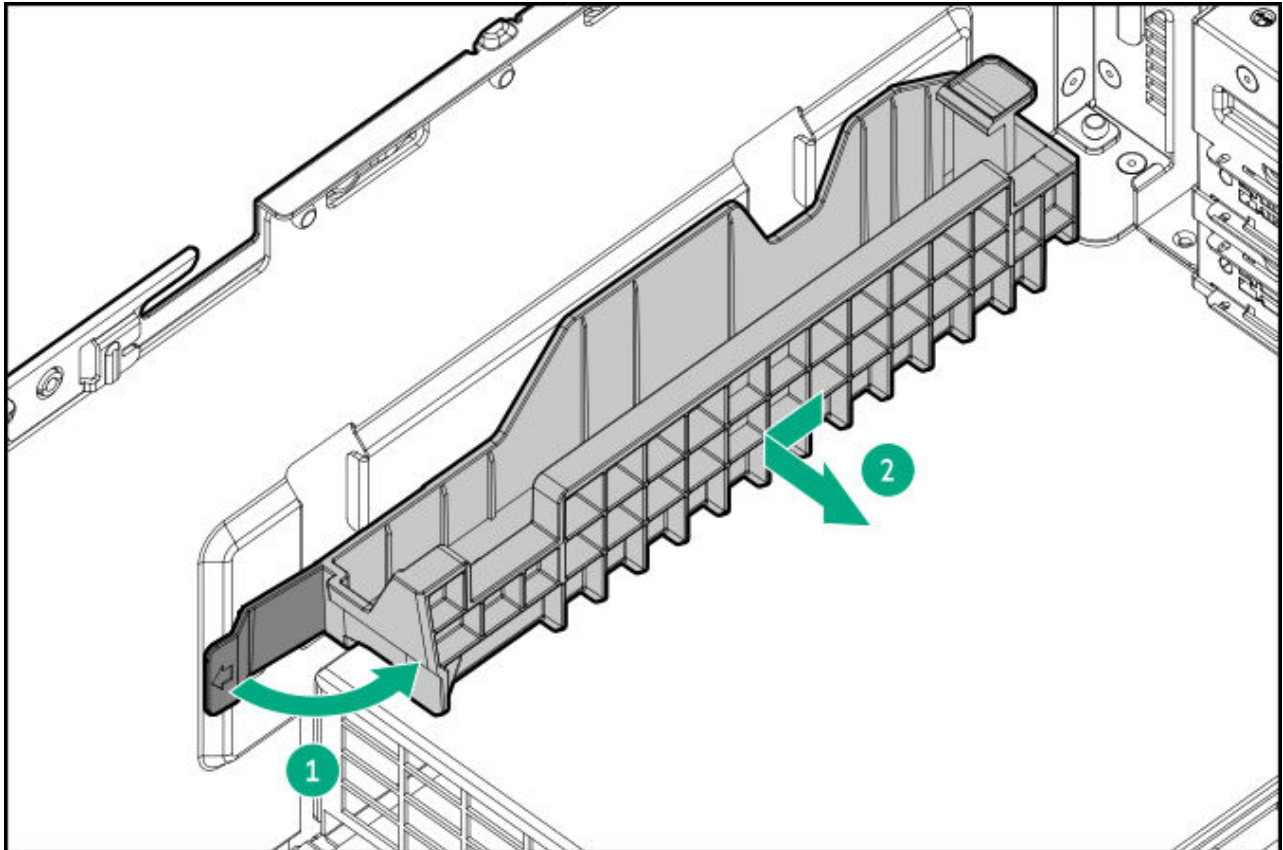

Results

The removal procedure is complete. To replace the component, reverse this procedure.

Expansion card replacement

Subtopics

[Removing and replacing an expansion card from the primary or secondary riser cage](#)

[Removing and replacing an expansion card from the tertiary riser](#)

Removing and replacing an expansion card from the primary or secondary riser cage

Prerequisites

Before you perform this procedure, make sure that you have a T-10 Torx screwdriver available.

About this task



CAUTION

To prevent improper cooling and thermal damage, do not operate the server unless all PCIe slots have either a riser slot blank or an expansion card installed.



CAUTION

Before replacing a DIMM, backplane, expansion card, riser board, or other similar PCA components due to a perceived hardware error, make sure first that the component is firmly seated in the slot.

When installing the replacement component:

- Observe antistatic precautions.
- Handle the PCA only along the edges.
- Do not touch the components and connectors on the PCA.
- Do not bend or flex the PCA.

Procedure

1. Power down the server.
2. Remove all power:
 - a. Disconnect each power cord from the power source.
 - b. Disconnect each power cord from the server.

3. Disconnect all peripheral cables from the server.
4. If the server is in tower mode, place the server on a flat, level surface with the access panel facing up.
5. If the server is in rack mode, do one of the following:
 - Extend the server from the rack.
 - Remove the server from the rack.
6. Unlock the front bezel.
7. Remove the access panel.
8. Disconnect any internal cables that are connected to the expansion card.
9. Do one of the following:
 - Remove the primary riser cage.
 - Remove the secondary riser cage.
10. Disconnect all internal cables from the expansion card. If removing a high power GPU, disconnect the GPU auxiliary power cable.
11. Remove the expansion card:
 - a. Simultaneously push and rotate to close the riser cage latch.
 - b. Remove the screw, and then remove the expansion card.

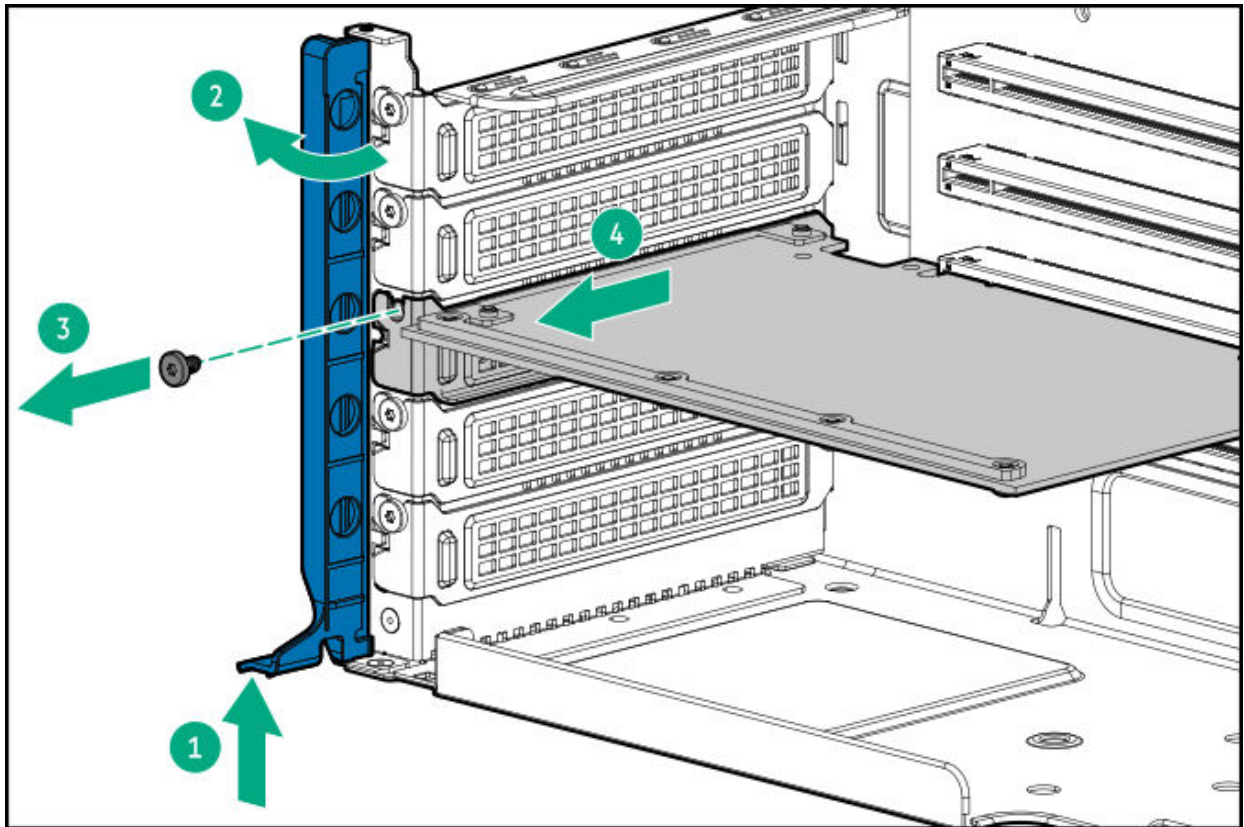

Results

The removal procedure is complete. To replace the component, reverse this procedure.

Removing and replacing an expansion card from the tertiary riser

Prerequisites

Before you perform this procedure, make sure that you have a T-10 Torx screwdriver available.

About this task



CAUTION

To prevent improper cooling and thermal damage, do not operate the server unless all PCIe slots have either a riser slot blank or an expansion card installed.



CAUTION

Before replacing a DIMM, backplane, expansion card, riser board, or other similar PCA components due to a perceived hardware error, make sure first that the component is firmly seated in the slot.

When installing the replacement component:

- Observe antistatic precautions.
- Handle the PCA only along the edges.
- Do not touch the components and connectors on the PCA.
- Do not bend or flex the PCA.

Procedure

1. Power down the server.
2. Remove all power:
 - a. Disconnect each power cord from the power source.
 - b. Disconnect each power cord from the server.
3. Disconnect all peripheral cables from the server.
4. If the server is in tower mode, place the server on a flat, level surface with the access panel facing up.
5. If the server is in rack mode, do one of the following:
 - Extend the server from the rack.
 - Remove the server from the rack.
6. Unlock the front bezel.
7. Remove the access panel.
8. Disconnect any internal cables that are connected to the expansion card.
9. If an expansion card with internal cables is installed on the riser, disconnect the cables from the card.

.0. If installed, remove the following hardware components:

a. Boot device cage assembly

b. Energy pack

c. Energy pack holder

.1. Remove the expansion card:

a. Loosen the stabilizer bracket captive screw, and then pull the bracket from the expansion card.

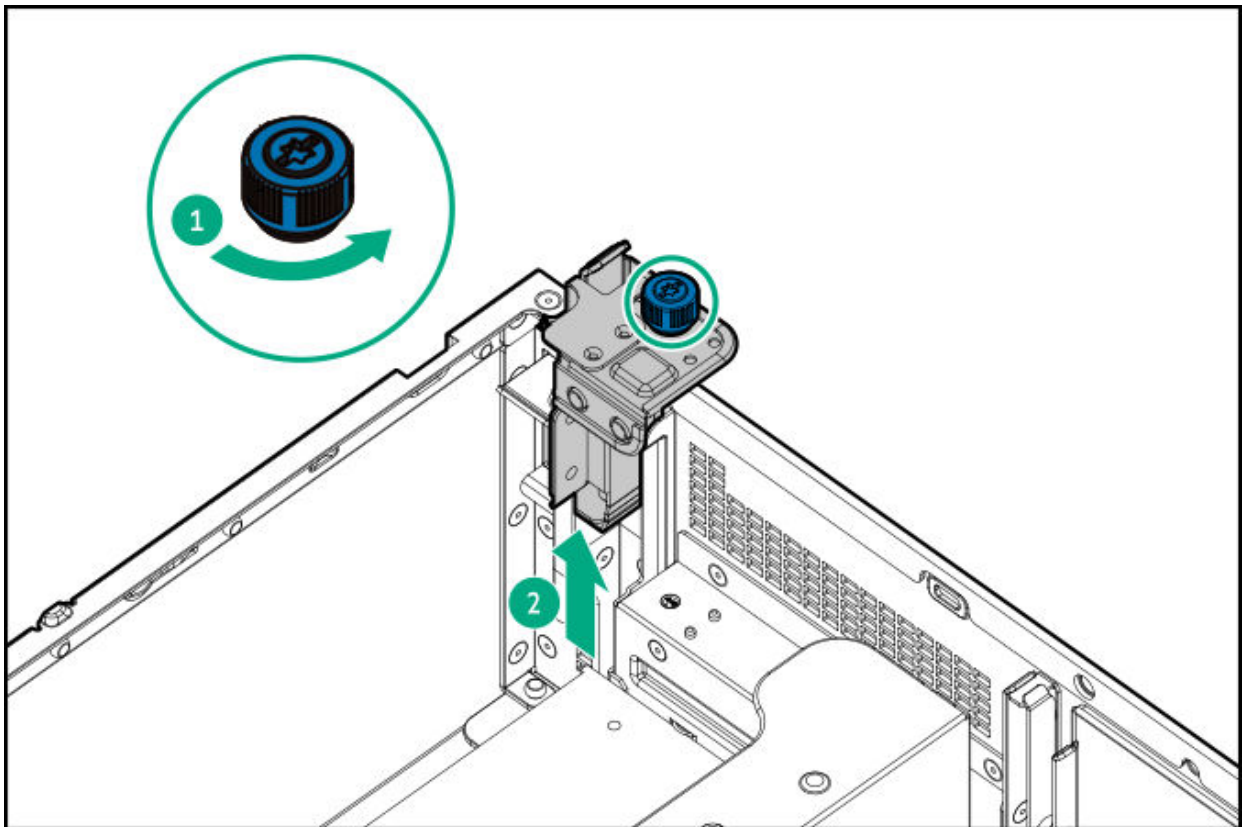

b. Remove the expansion card from the tertiary riser.

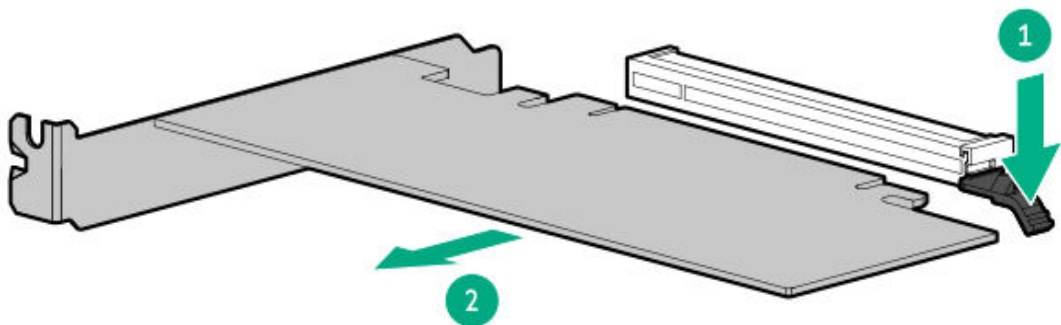

2. Remove all power:
 - a. Disconnect each power cord from the power source.
 - b. Disconnect each power cord from the server.
3. Disconnect all peripheral cables from the server.
4. If the server is in tower mode, place the server on a flat, level surface with the access panel facing up.
5. If the server is in rack mode, do one of the following:
 - Extend the server from the rack.
 - Remove the server from the rack.
6. Unlock the front bezel.
7. Remove the access panel.
8. Do one of the following:
 - Remove the primary riser cage.
 - Remove the secondary riser cage.
9. If installed, remove any expansion card from the riser.
10. Remove the retainer bracket.

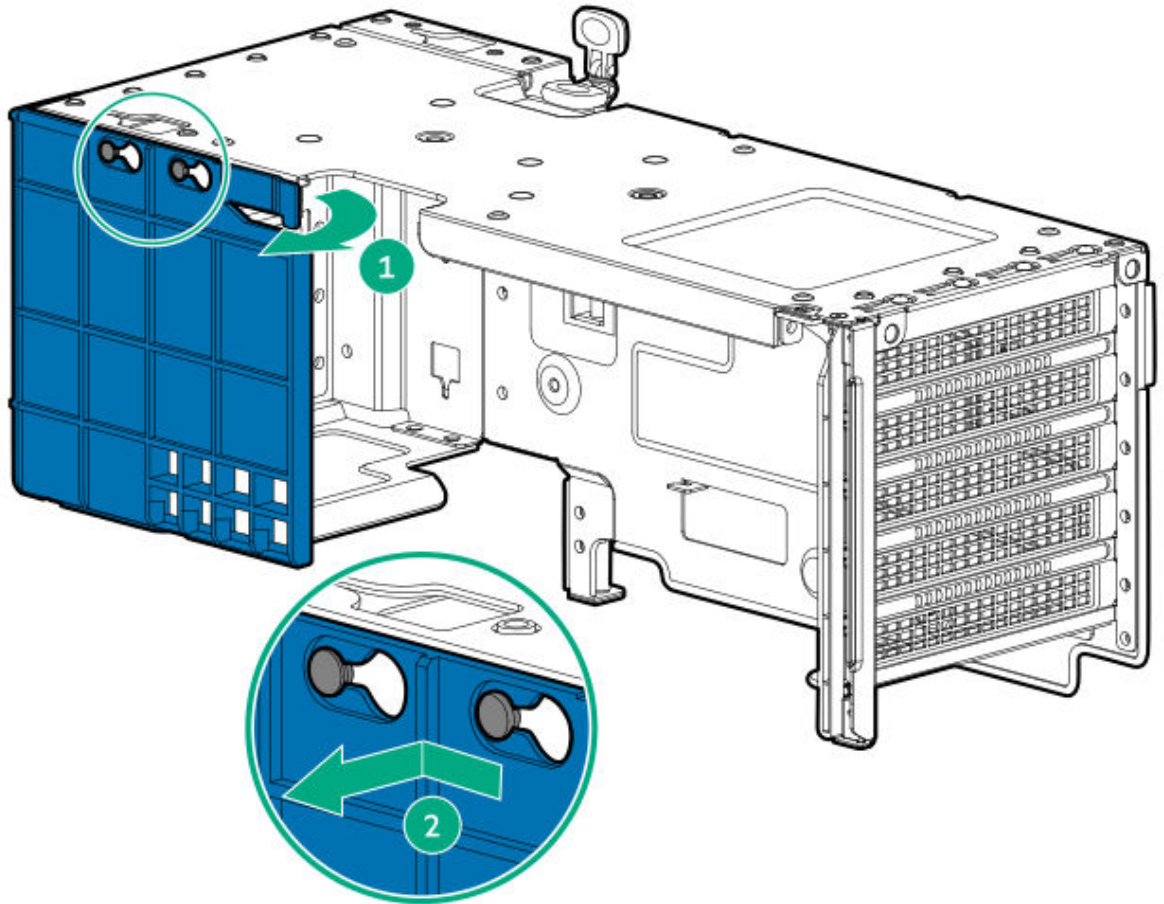

.1. Remove the primary/secondary riser board.

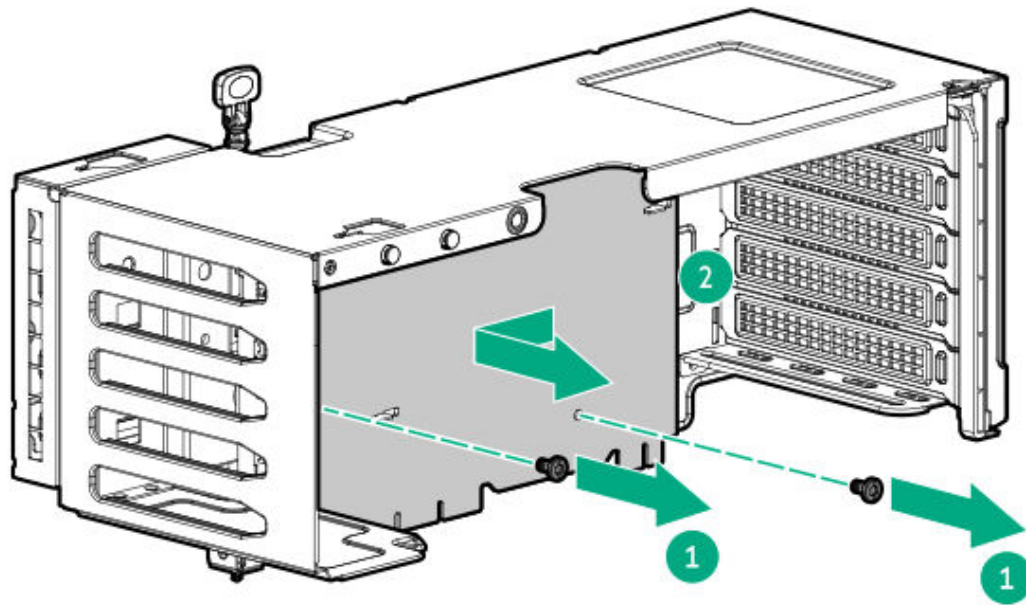

Results

The removal procedure is complete. To replace the component, reverse this procedure.

Removing and replacing the tertiary riser board

Prerequisites

Before you perform this procedure, make sure that you have a T-15 Torx screwdriver available.

About this task

<https://sketchfab.com/models/62e2cc05e44648a482fa0bf9b4644547/embed?>



CAUTION

Before replacing a DIMM, backplane, expansion card, riser board, or other similar PCA components due to a perceived hardware error, make sure first that the component is firmly seated in the slot.

When installing the replacement component:

- Observe antistatic precautions.
- Handle the PCA only along the edges.
- Do not touch the components and connectors on the PCA.
- Do not bend or flex the PCA.

Procedure

1. Power down the server.
2. Remove all power:
 - a. Disconnect each power cord from the power source.
 - b. Disconnect each power cord from the server.
3. Disconnect all peripheral cables from the server.
4. If the server is in tower mode, place the server on a flat, level surface with the access panel facing up.
5. If the server is in rack mode, do one of the following:
 - Extend the server from the rack.
 - Remove the server from the rack.
6. Unlock the front bezel.
7. Remove the access panel.
8. If the expansion card is installed on the tertiary riser, remove the following hardware components:
 - a. Boot device cage assembly
 - b. Energy pack
 - c. Energy pack holder
 - d. Expansion card

9. Remove the tertiary riser.

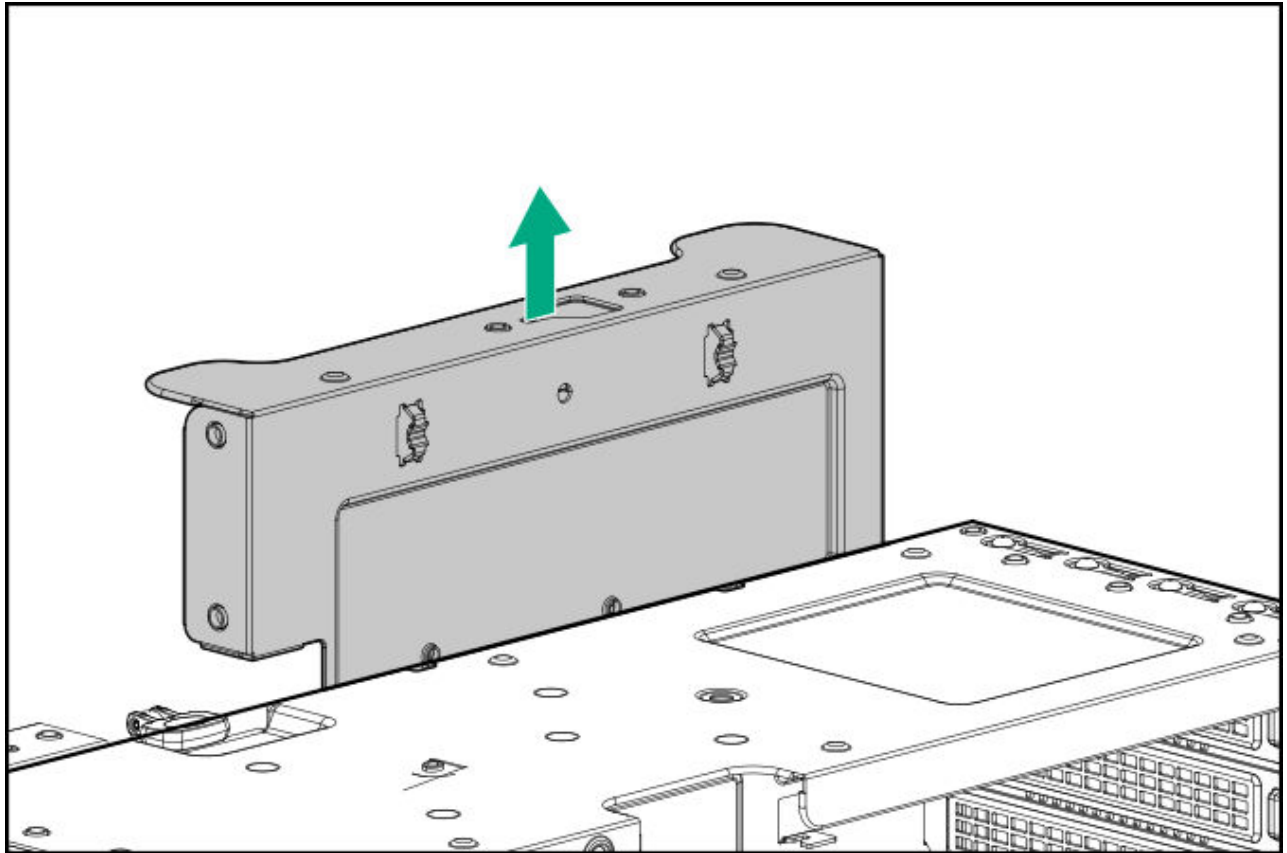

10. Remove the tertiary riser board.

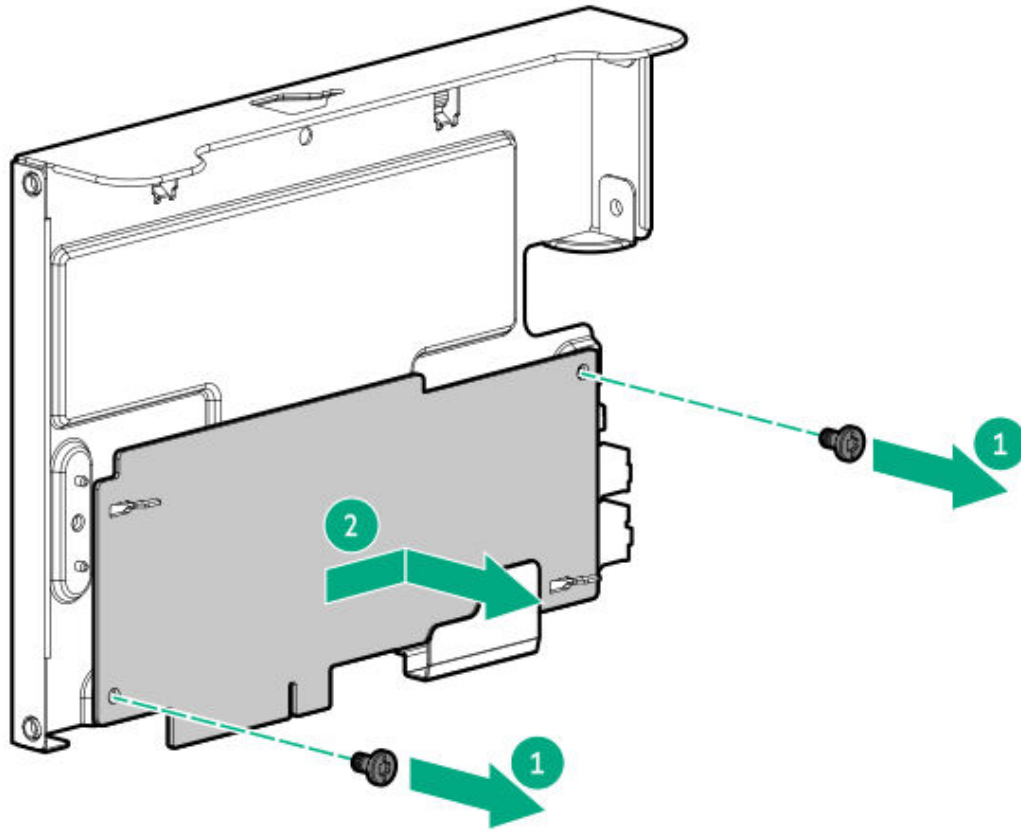

Results

The removal procedure is complete. To replace the component, reverse this procedure.

Removing and replacing a type-o storage controller

About this task

<https://sketchfab.com/models/ac02ab5a52f140faa5c7e7a4444f9683/embed?>



CAUTION

The port blank provides EMI shielding and helps maintain proper thermal status inside the server. Do not operate the server when a port blank is removed without the corresponding I/O port option installed.



CAUTION

Before replacing a DIMM, backplane, expansion card, riser board, or other similar PCA components due to a perceived hardware error, make sure first that the component is firmly seated in the slot.

When installing the replacement component:

- Observe antistatic precautions.
- Handle the PCA only along the edges.
- Do not touch the components and connectors on the PCA.
- Do not bend or flex the PCA.

Procedure

1. Power down the server.
2. Remove all power:
 - a. Disconnect each power cord from the power source.
 - b. Disconnect each power cord from the server.
3. Disconnect all peripheral cables from the server.
4. If the server is in tower mode, place the server on a flat, level surface with the access panel facing up.
5. If the server is in rack mode, do one of the following:
 - Extend the server from the rack.
 - Remove the server from the rack.
6. Unlock the front bezel.
7. Remove the access panel.
8. Remove the primary riser cage.

9. Disconnect the storage cables from the type-o controller.
10. Remove the type-o storage controller:
 - a. Rotate the locking pin to the open (vertical) position.
 - b. Slide the controller out of the bay.

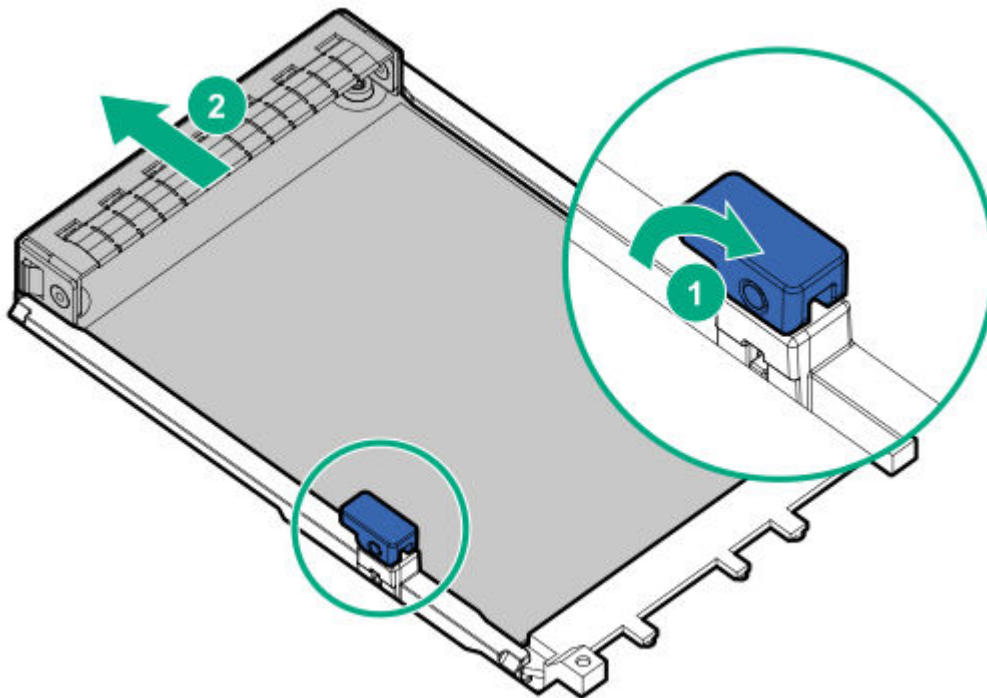

Results

The removal procedure is complete. To replace the component, reverse this procedure.

Removing and replacing the OCP NIC adapter

About this task

<https://sketchfab.com/models/ac02ab5a52f140faa5c7e7a4444f9683/embed?>



CAUTION

Before replacing a DIMM, backplane, expansion card, riser board, or other similar PCA components due to a perceived hardware error, make sure first that the component is firmly seated in the slot.

When installing the replacement component:

- Observe antistatic precautions.
- Handle the PCA only along the edges.
- Do not touch the components and connectors on the PCA.
- Do not bend or flex the PCA.



CAUTION

To prevent improper cooling and thermal damage, do not operate the server unless all OCP slots have either an OCP option or a slot blank installed.

Procedure

1. Power down the server.
2. Remove all power:
 - a. Disconnect each power cord from the power source.
 - b. Disconnect each power cord from the server.
3. Disconnect all peripheral cables from the server.
4. If the server is in tower mode, place the server on a flat, level surface with the access panel facing up.
5. If the server is in rack mode, do one of the following:
 - Extend the server from the rack.
 - Remove the server from the rack.
6. Unlock the front bezel.
7. Remove the access panel.
8. Do the following:
 - If replacing the adapter on Slot 14 OCP A, remove the primary riser cage.

- If replacing the adapter on Slot 15 OCP B, remove the secondary riser cage.

9. Remove the OCP NIC:

- a. Rotate the locking pin to the open (vertical) position.
- b. Slide the OCP NIC out of the bay.

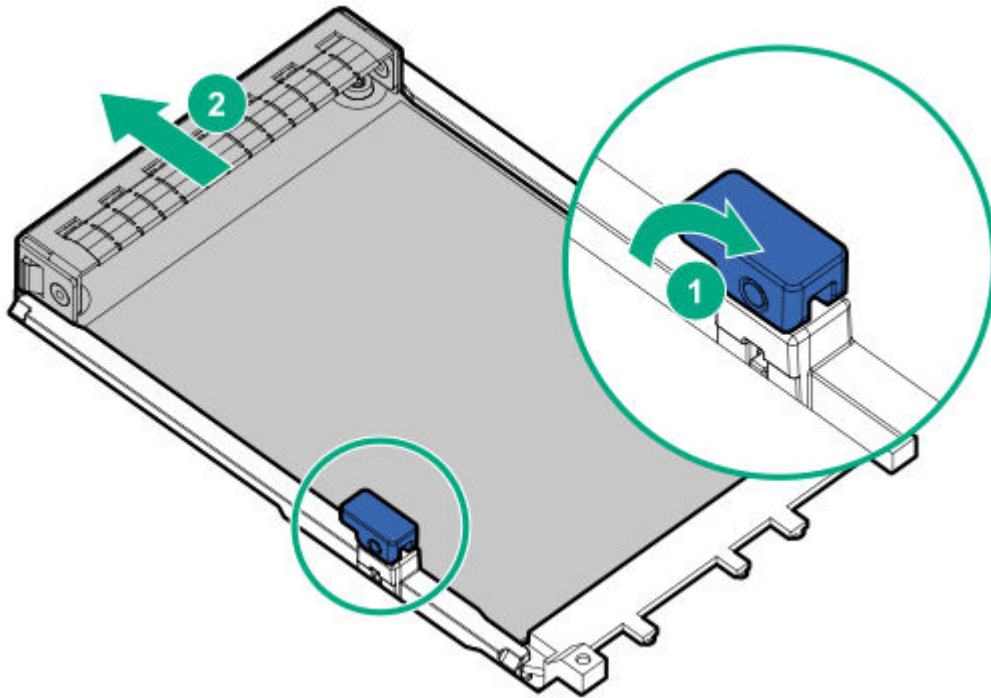

Results

The removal procedure is complete. To replace the component, reverse this procedure.

Removing and replacing an OCP slot blank

Prerequisites

Before you perform this procedure, make sure that you have a T-10 Torx screwdriver available.

About this task



CAUTION

The port blank provides EMI shielding and helps maintain proper thermal status inside the server. Do not operate the server when a port blank is removed without the corresponding I/O port option installed.

Procedure

1. Power down the server.
2. Remove all power:
 - a. Disconnect each power cord from the power source.
 - b. Disconnect each power cord from the server.
3. Disconnect all peripheral cables from the server.
4. If the server is in tower mode, place the server on a flat, level surface with the access panel facing up.
5. If the server is in rack mode, do one of the following, remove the server from the rack.
6. Unlock the front bezel.
7. Remove the access panel.
8. Do one of the following:
 - Remove the primary riser cage.
 - Remove the secondary riser cage.
9. Remove the OCP slot blank:
 - a. Remove the blank screw.
 - b. Use a plastic spudger to pry the top side of the blank from the chassis.
 - c. Remove the blank.

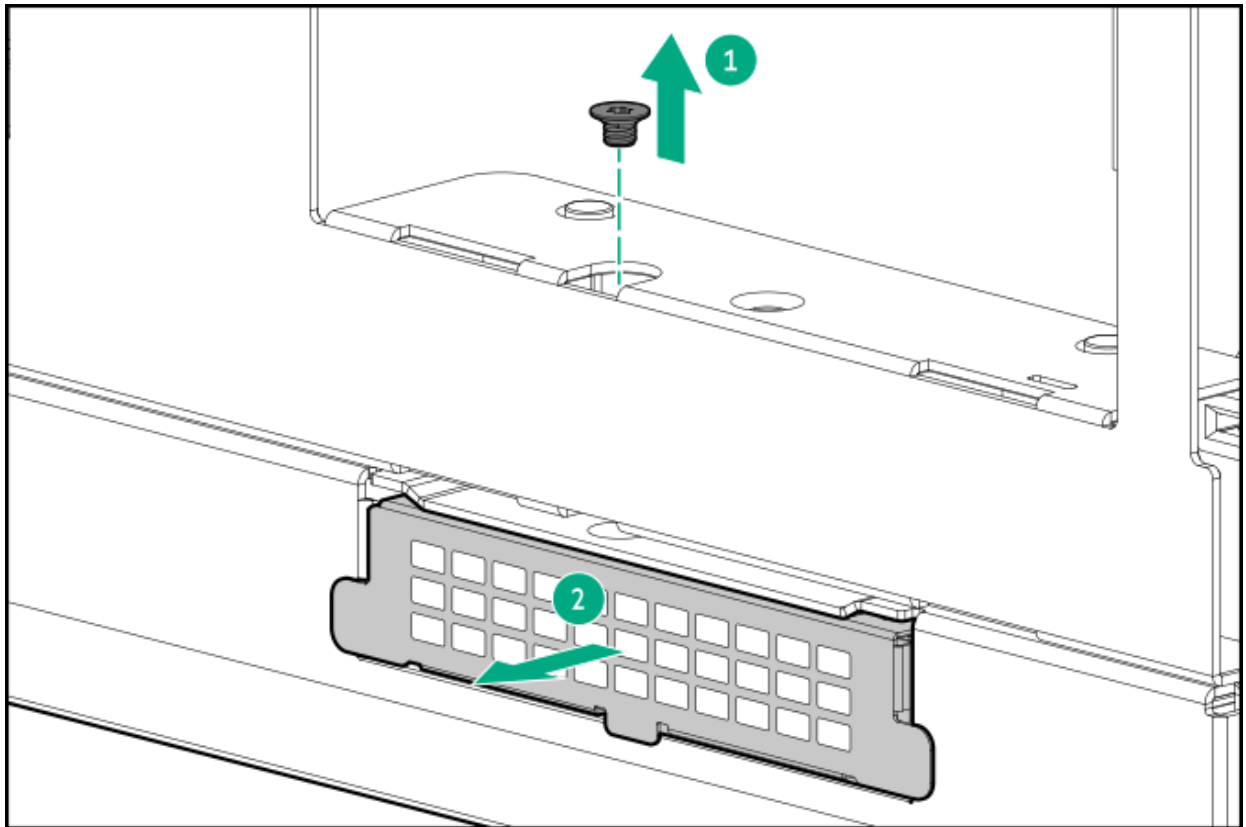

Results

The removal procedure is complete. To replace the component, reverse this procedure.

Removing and replacing the left OCP A Slot 14 rail

Prerequisites

Before you perform this procedure, make sure that you have a T-10 Torx screwdriver available.

About this task

<https://sketchfab.com/models/a107a3f430b74e75bdc6129eb076fcc2/embed?>



CAUTION

A discharge of static electricity from a finger or other conductor might damage system boards or other static-sensitive devices. To prevent damage, observe [antistatic precautions](#).

Procedure

1. [Power down the server](#).
2. Remove all power:
 - a. Disconnect each power cord from the power source.
 - b. Disconnect each power cord from the server.
3. Disconnect all peripheral cables from the server.
4. If the server is in tower mode, [place the server on a flat, level surface with the access panel facing up](#).
5. If the server is in rack mode, do one of the following, [remove the server from the rack](#).
6. Unlock the front bezel.
7. [Remove the access panel](#).
8. [Remove the primary riser cage](#).
9. If installed, remove one of the following:
 - [Remove the OCP NIC adapter](#)
 - [Removing and replacing a type-o storage controller](#)
10. Remove the left OCP A Slot 14 rail:
 - a. Remove the rail screws.
 - b. Pivot the rear end of the rail inward until the entire rail is not covered by the end chassis.
 - c. Remove the rail from the server.

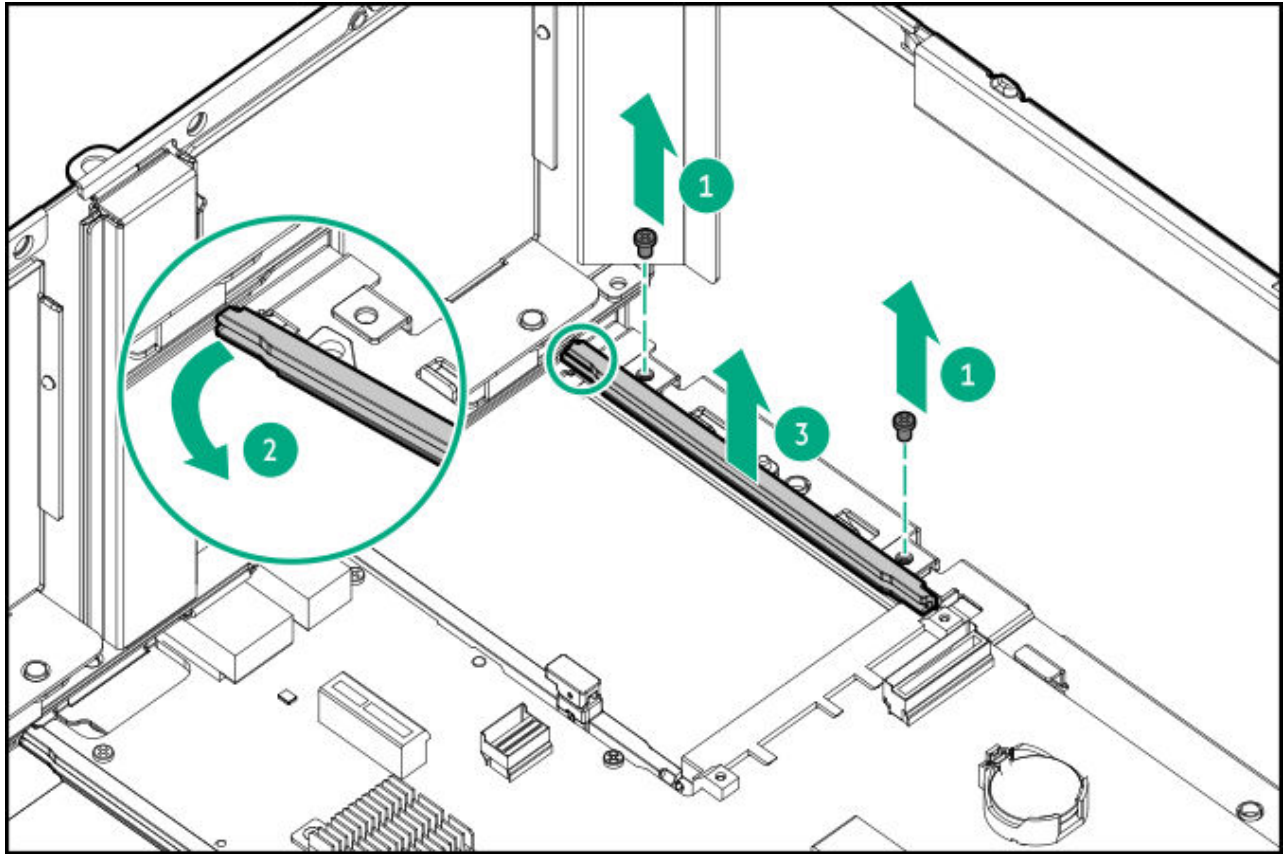

Results

The removal procedure is complete. To replace the component, reverse this procedure.

Removing and replacing the secondary riser cage blank

Prerequisites

Before you perform this procedure, make sure that you have a T-10 Torx screwdriver available.

About this task



CAUTION

To prevent improper cooling and thermal damage, do not operate the server unless all bays are populated with either a component or a blank.

Procedure

1. Power down the server.

2. Remove all power:
 - a. Disconnect each power cord from the power source.
 - b. Disconnect each power cord from the server.
3. Disconnect all peripheral cables from the server.
4. If the server is in tower mode, place the server on a flat, level surface with the access panel facing up.
5. If the server is in rack mode, do one of the following, remove the server from the rack.
6. Unlock the front bezel.
7. Remove the access panel.
8. Remove the secondary riser cage blank.

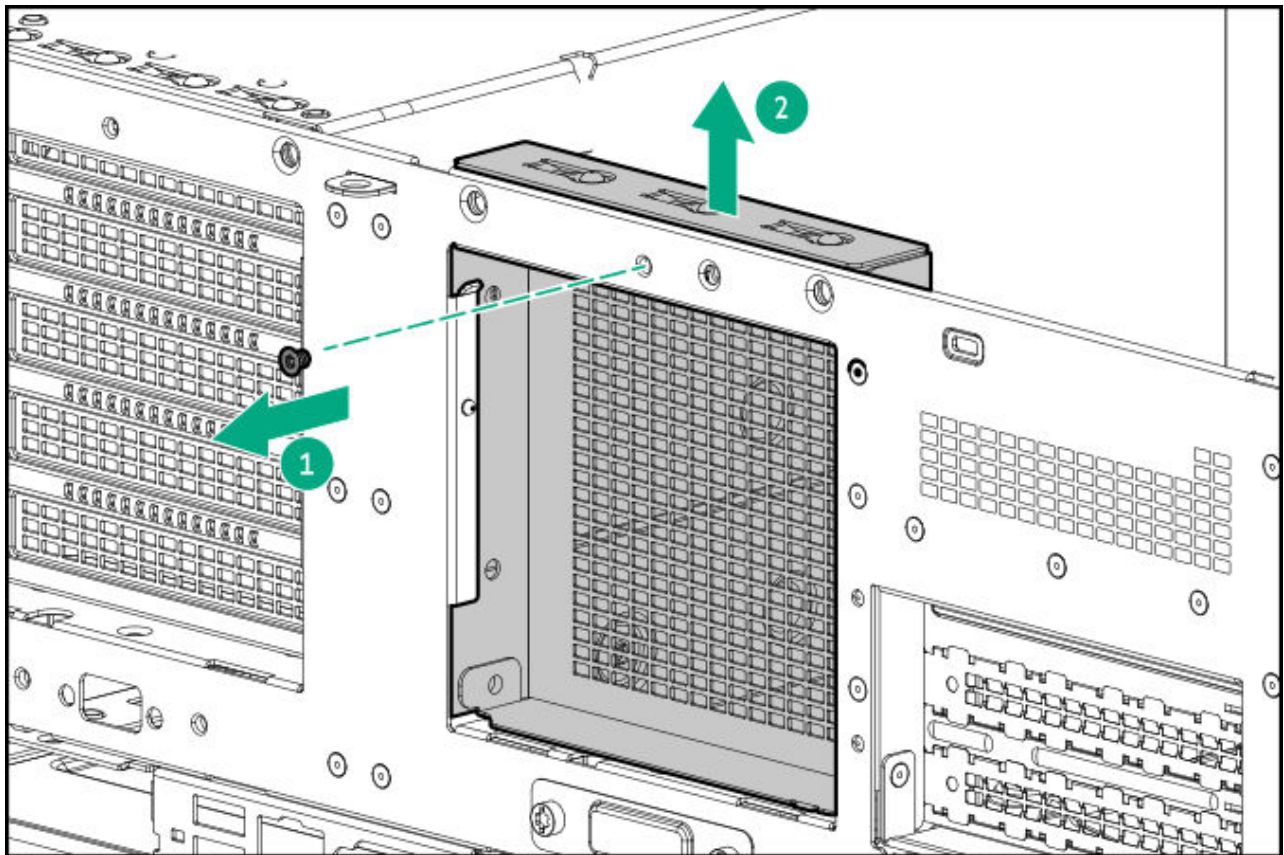

Results

The removal procedure is complete. To replace the component, reverse this procedure.

Removing and replacing the external fan connector blank

Prerequisites

Before you perform this procedure, make sure that you have a T-15 Torx screwdriver available.

About this task



CAUTION

To prevent improper cooling and thermal damage, do not operate the server unless all bays are populated with either a component or a blank.

Procedure

1. Power down the server.
2. Remove all power:
 - a. Disconnect each power cord from the power source.
 - b. Disconnect each power cord from the server.
3. Disconnect all peripheral cables from the server.
4. If the server is in tower mode, place the server on a flat, level surface with the access panel facing up.
5. If the server is in rack mode, do one of the following, remove the server from the rack.
6. Remove the external fan connector blank.

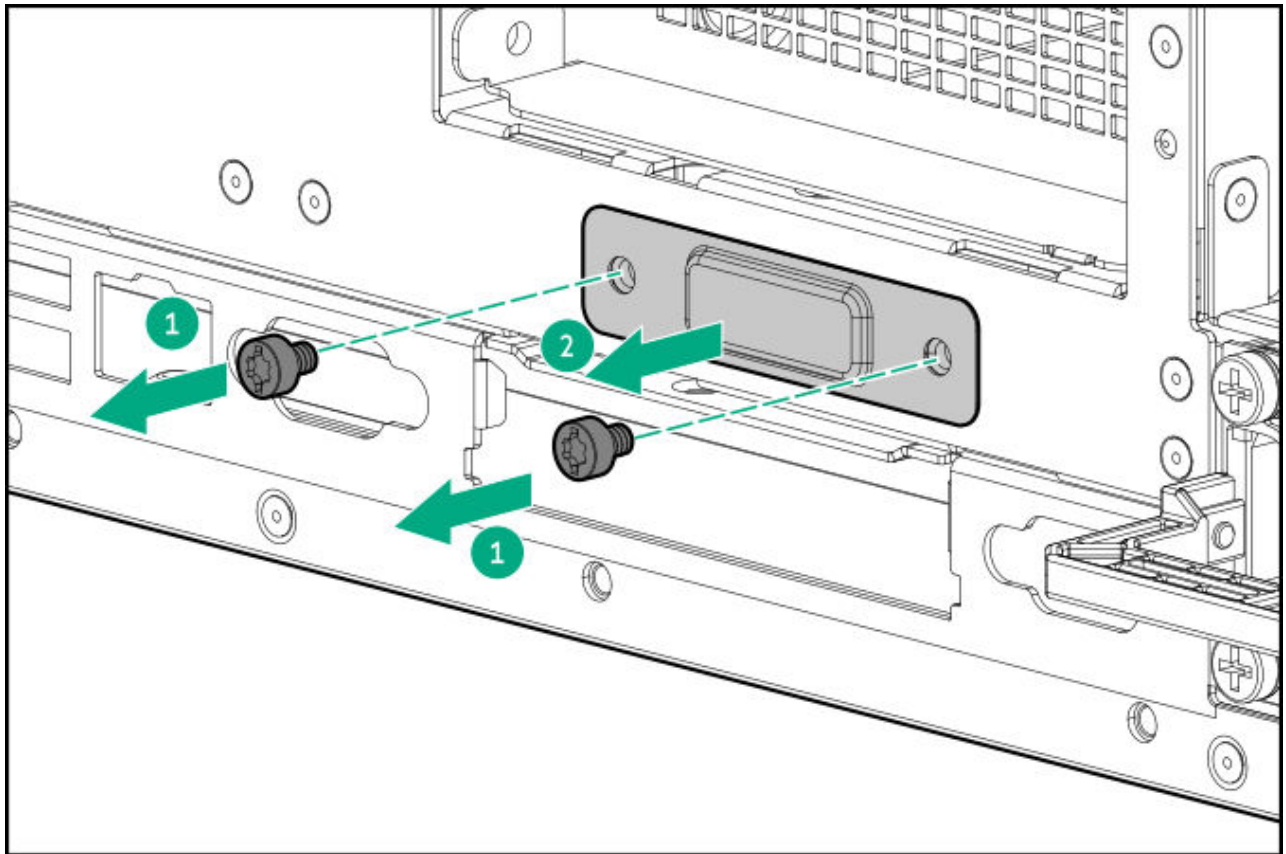

Results

The removal procedure is complete. To replace the component, reverse this procedure.

Removing and replacing the external fan cable

Prerequisites

Before you perform this procedure, make sure that you have a T-10 Torx screwdriver available.

Procedure

1. Power down the server.
2. Remove all power:
 - a. Disconnect each power cord from the power source.
 - b. Disconnect each power cord from the server.
3. Disconnect all peripheral cables from the server.

4. If the server is in tower mode, place the server on a flat, level surface with the access panel facing up.
5. If the server is in rack mode, do one of the following, remove the server from the rack.
6. Unlock the front bezel.
7. Remove the access panel.
8. Do one of the following:
 - Remove the primary riser cage.
 - Remove the secondary riser cage.
9. Remove the external fan.
10. Remove the external fan cable:
 - a. Remove the cable screw.
 - b. Remove the cable from the cable connector slot.

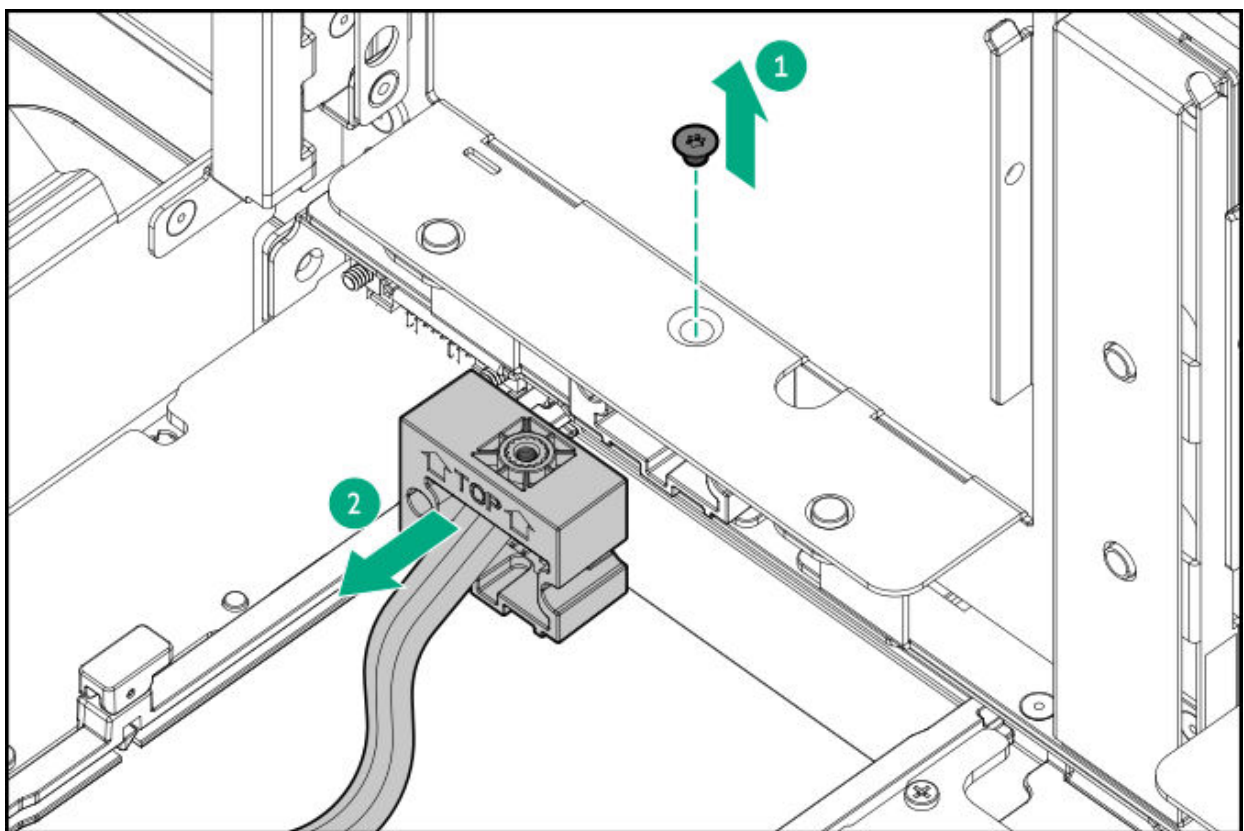

Results

The removal procedure is complete. To replace the component, reverse this procedure.

Removing and replacing the serial port cable

Prerequisites

Before you perform this procedure, make sure that you have a hex screwdriver available.

About this task



CAUTION

A discharge of static electricity from a finger or other conductor might damage system boards or other static-sensitive devices. To prevent damage, observe antistatic precautions.

Procedure

1. Power down the server.
2. Remove all power:
 - a. Disconnect each power cord from the power source.
 - b. Disconnect each power cord from the server.
3. Disconnect all peripheral cables from the server.
4. If the server is in tower mode, place the server on a flat, level surface with the access panel facing up.
5. If the server is in rack mode, do one of the following, remove the server from the rack.
6. Unlock the front bezel.
7. Remove the access panel.
8. If installed, remove the secondary riser cage.
9. Disconnect the serial port cable from the system board.
10. Remove the serial port cable:
 - a. Remove the hex screws.
 - b. Remove the serial port from the rear panel.

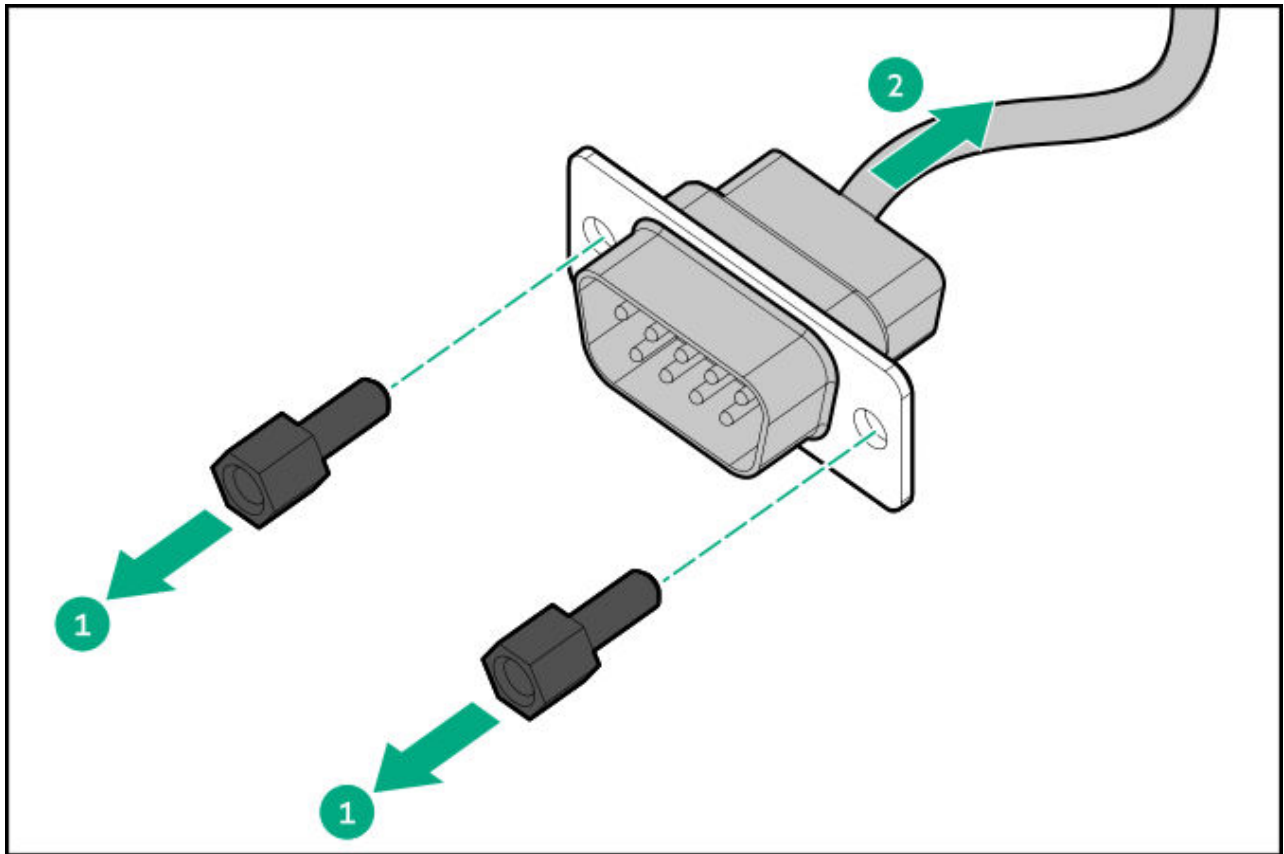

Results

The removal procedure is complete. To replace the component, reverse this procedure.

Removing and replacing the serial port blank

Prerequisites

Before you perform this procedure, make sure that you have a spudger or any small prying tool available.

About this task



CAUTION

The port blank provides EMI shielding and helps maintain proper thermal status inside the server. Do not operate the server when a port blank is removed without the corresponding I/O port option installed.

Procedure

1. [Power down the server.](#)

2. Remove all power:
 - a. Disconnect each power cord from the power source.
 - b. Disconnect each power cord from the server.
3. Disconnect all peripheral cables from the server.
4. If the server is in tower mode, place the server on a flat, level surface with the access panel facing up.
5. If the server is in rack mode, do one of the following:
 - Extend the server from the rack.
 - Remove the server from the rack.
6. Remove the serial port blank:
 - a. Use a plastic spudger to pry the blank from the rear panel.
 - b. Remove the blank.

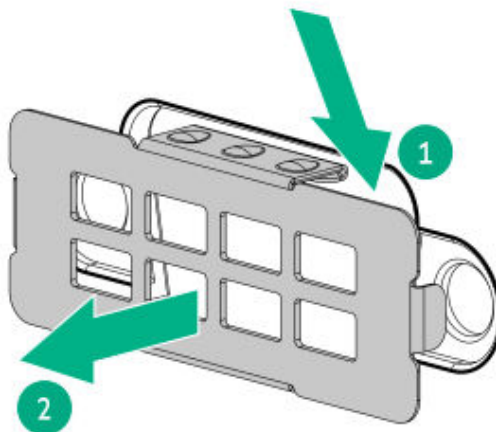

Results

The removal procedure is complete. To replace the component, reverse this procedure.

Removing and replacing the tertiary riser slot cover

Prerequisites

Before you perform this procedure, make sure that you have a spudger or any small prying tool available.

About this task



CAUTION

To prevent improper cooling and thermal damage, do not operate the server unless all bays are populated with either a component or a blank.

Procedure

1. Power down the server.
2. Remove all power:
 - a. Disconnect each power cord from the power source.
 - b. Disconnect each power cord from the server.
3. Disconnect all peripheral cables from the server.
4. If the server is in tower mode, place the server on a flat, level surface with the access panel facing up.
5. If the server is in rack mode, do one of the following:
 - Extend the server from the rack.
 - Remove the server from the rack.
6. Remove the tertiary riser slot cover:
 - a. Use a plastic spudger to pry the top side of the cover from the chassis.
 - b. Remove the blank.

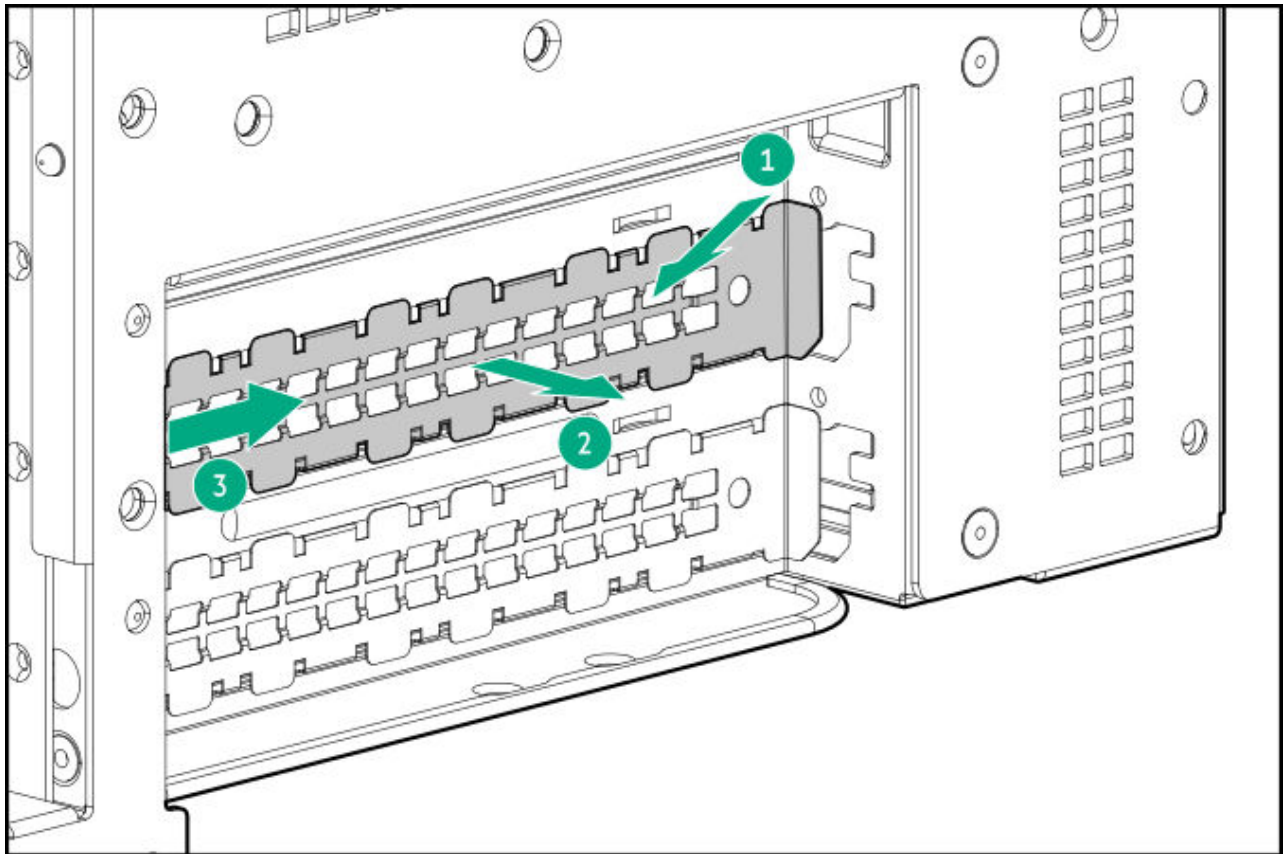

Results

The removal procedure is complete. To replace the component, reverse this procedure.

Heatsink replacement

Subtopics

[Removing the heatsink](#)

[Installing the heatsink](#)

Removing the heatsink

Prerequisites

- [Identify the heatsink and processor socket components.](#)
- [Review the processor cautions.](#)

- Before you perform this procedure, make sure that you have the following items available:
 - T-30 Torx screwdriver
 - Alcohol wipe
- If you are not immediately installing the replacement processor-heatsink assembly, make sure that you have a processor socket dust cover.

About this task



WARNING

To reduce the risk of personal injury from hot surfaces, allow the drives and the internal system components to cool before touching them.



CAUTION

A discharge of static electricity from a finger or other conductor might damage system boards or other static-sensitive devices. To prevent damage, observe antistatic precautions.

Procedure

1. Power down the server.
2. Remove all power:
 - a. Disconnect each power cord from the power source.
 - b. Disconnect each power cord from the server.
3. Disconnect all peripheral cables from the server.
4. If the server is in tower mode, place the server on a flat, level surface with the access panel facing up.
5. If the server is in rack mode, do one of the following, remove the server from the rack.
6. Unlock the front bezel.
7. Remove the access panel.
8. Do the following:
 - Remove the primary riser cage.
 - Remove the secondary riser cage.
9. Remove the fan cage.
10. Allow all internal system components to cool before continuing.

.1. Loosen one pair of diagonally opposite screws, and then loosen the other pair of screws.



CAUTION

Heatsink screws must be tightened and loosened in alternating sequence. Do not overtighten the screws as this might damage the system board or the processor socket.

- Standard heatsink

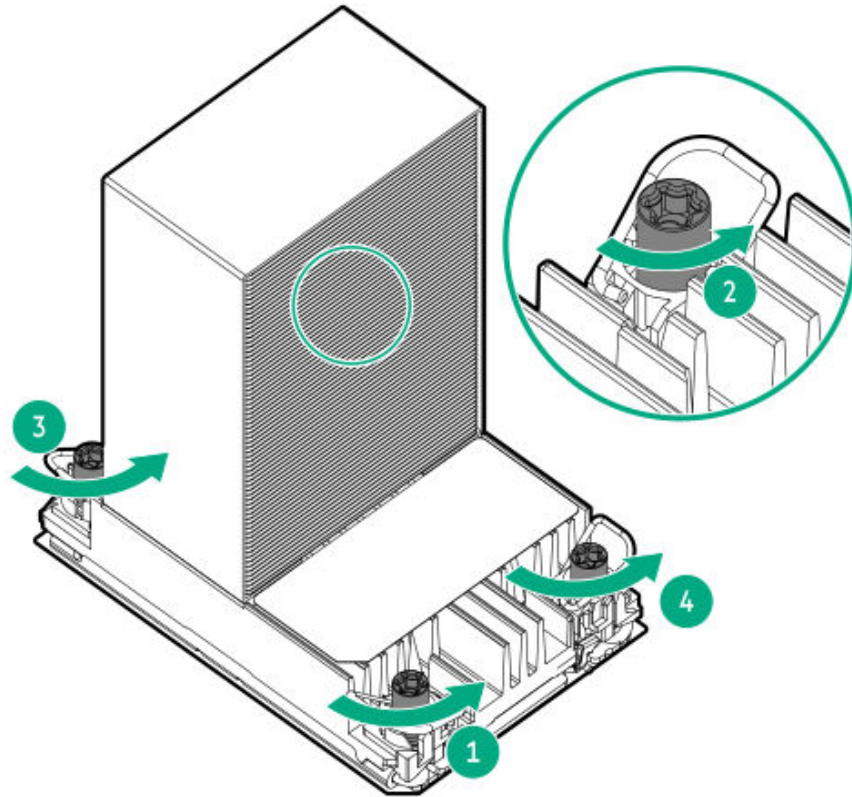

- Performance heatsink

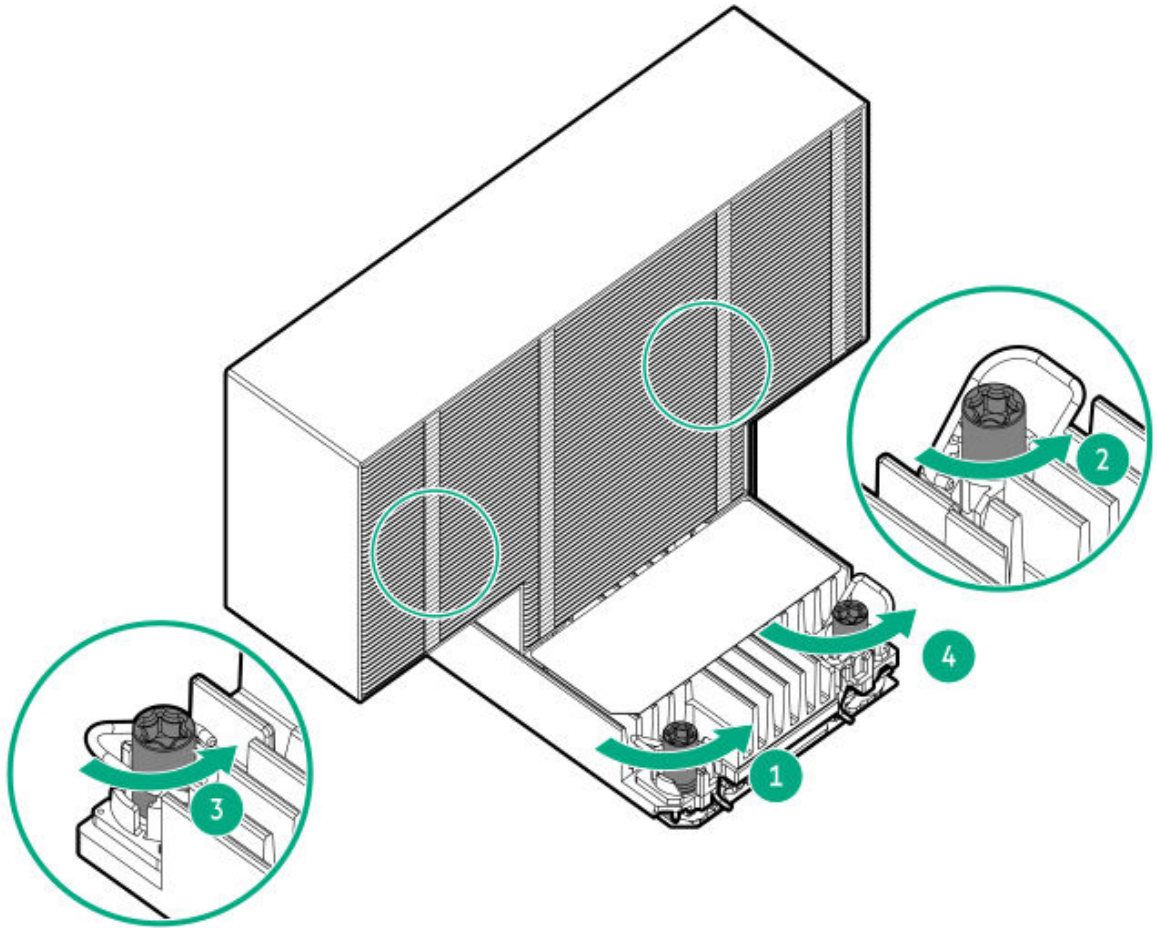

.2. Set the anti-tilt wires to the unlocked position.

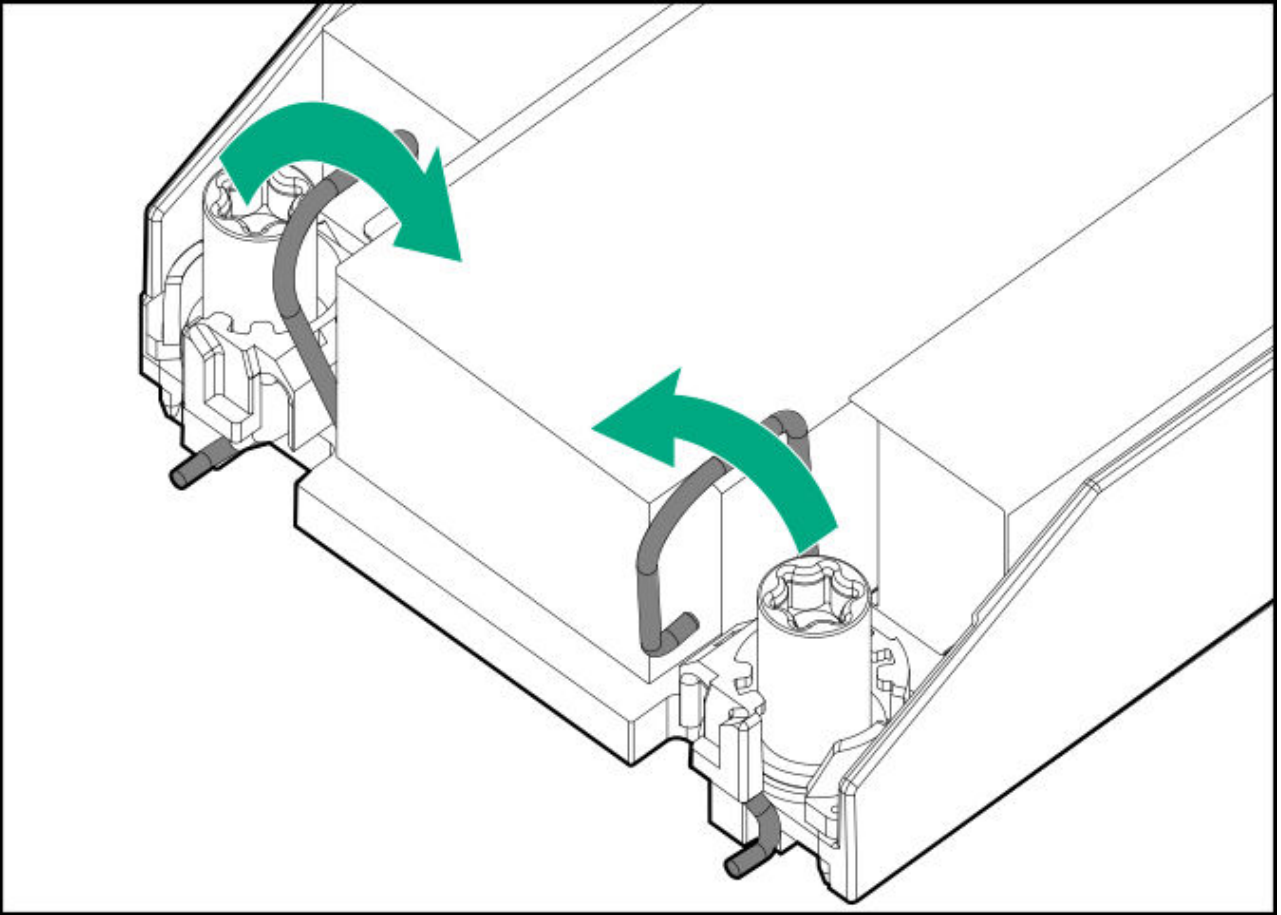

.3. Lift the processor-heatsink module straight up from the system board.



CAUTION

To prevent mechanical damage or depositing oil on your hands or other contaminants to the heatsink contact surface, hold the heatsink only by the edge of its base plate. Do not touch the heatsink fins.

- Standard heatsink

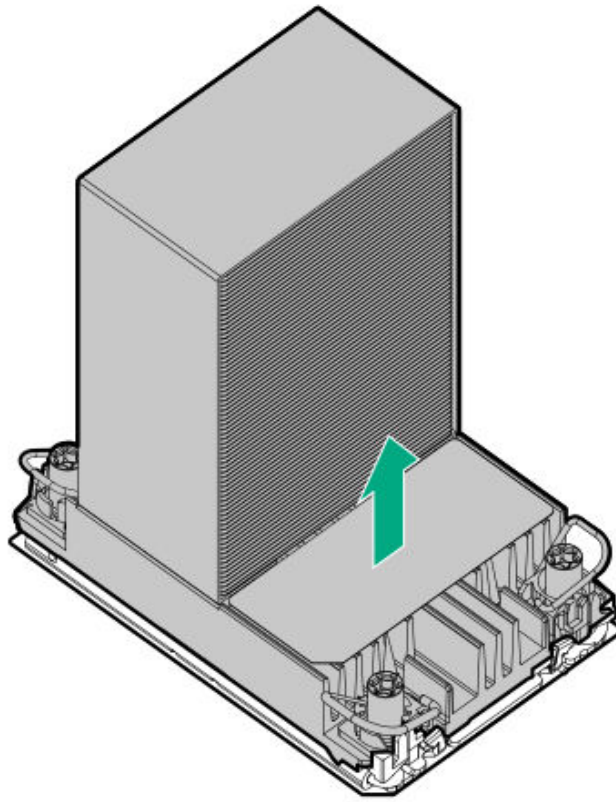

- Performance heatsink

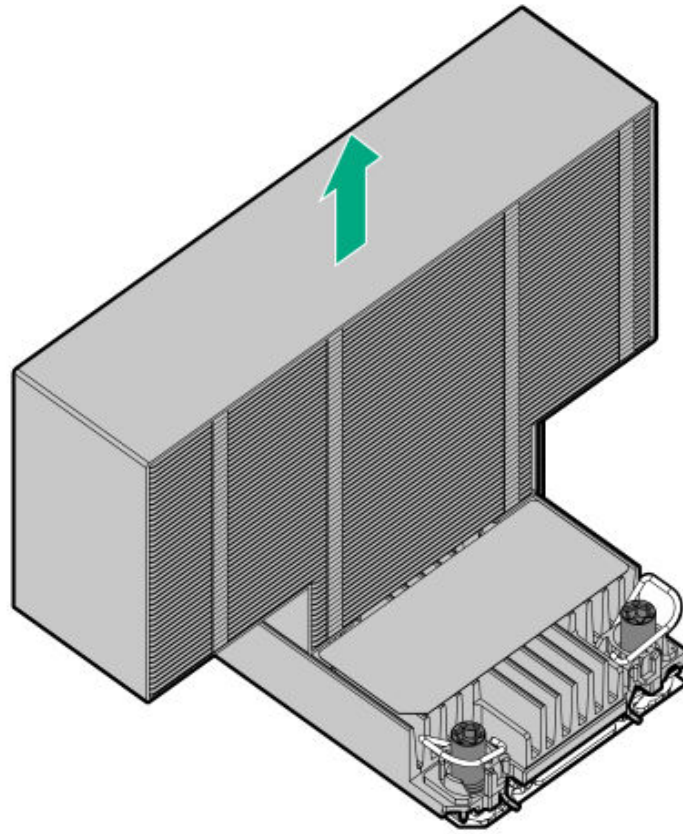

.4. Set the anti-tilt wires to the locked position.

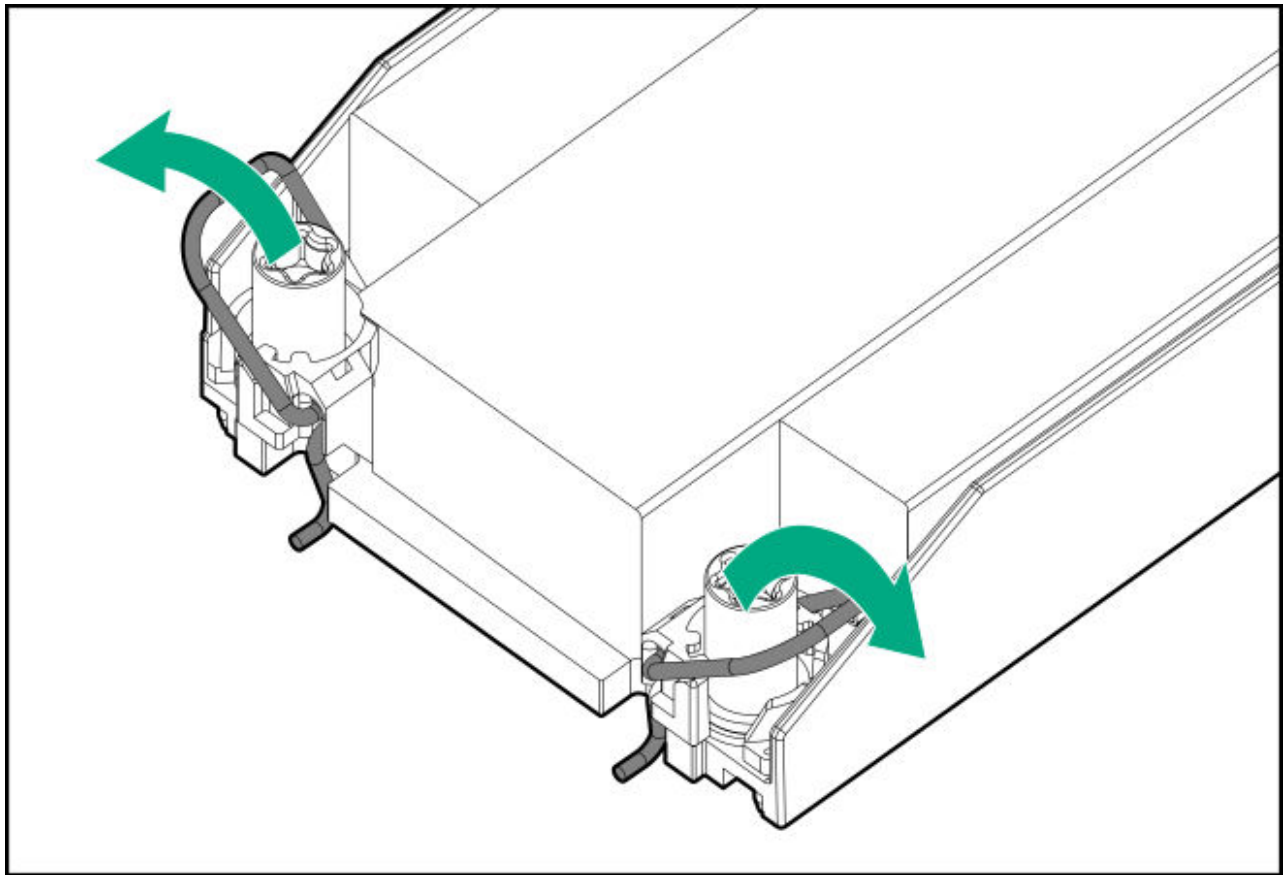

- .5. Place the processor-heatsink module on a flat work surface with its contact side facing up.
- .6. If you are not immediately installing the replacement processor-heatsink module, install the dust cover on the empty processor socket:



CAUTION

Do not press down on the dust cover. Pressing down on the dust cover might damage the processor socket.

- a. Press and hold the grip tabs on the dust cover.
- b. Carefully lower the dust cover onto the bolster plate guide posts.

Make sure that the corner holes of the dust cover are properly engaged with the guide posts on the bolster plate.

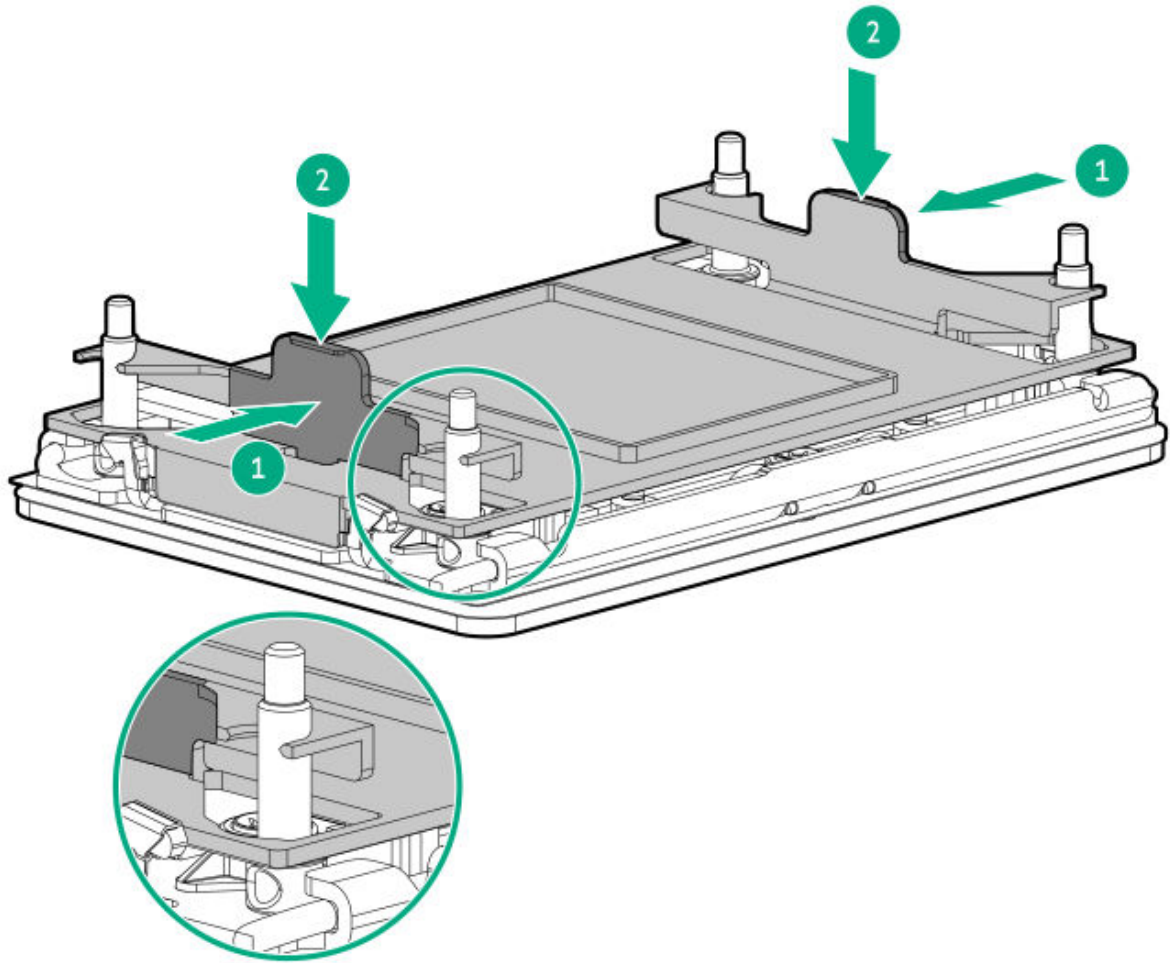

.7. Do not touch the pins on the processor socket and the processor.



CAUTION

THE PINS ON THE PROCESSOR SOCKET AND ON THE PROCESSOR ARE VERY FRAGILE AND EASILY DAMAGED. Any damage to them might require replacing the system board.

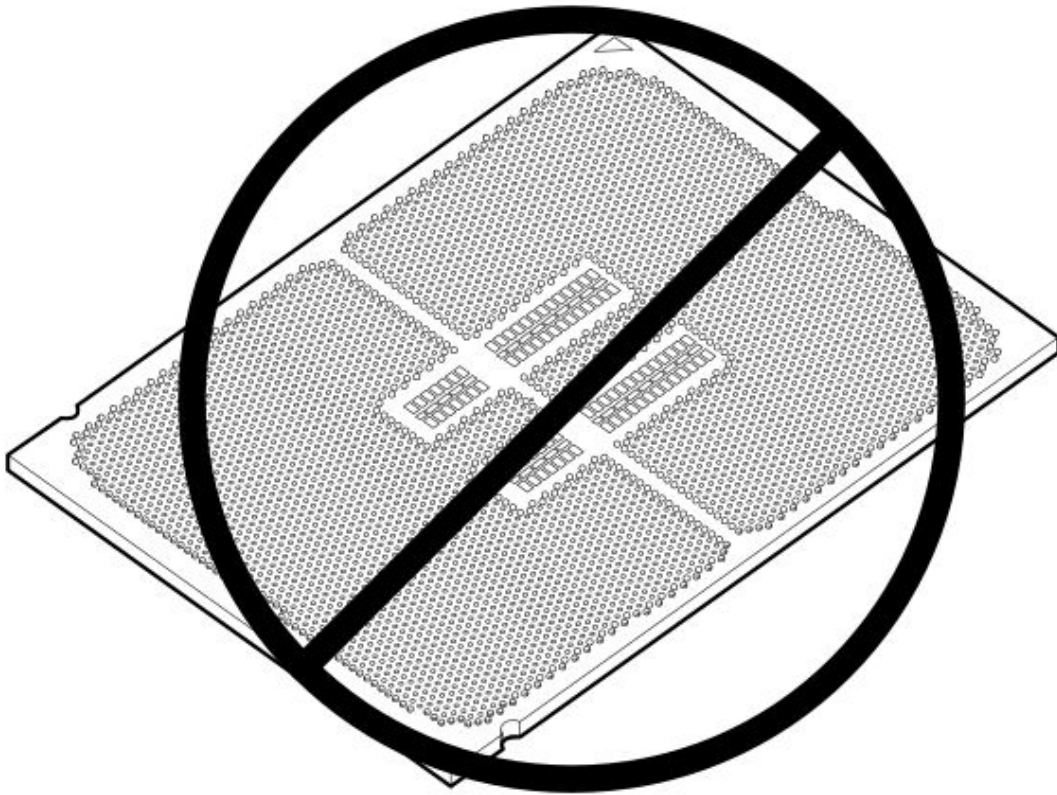
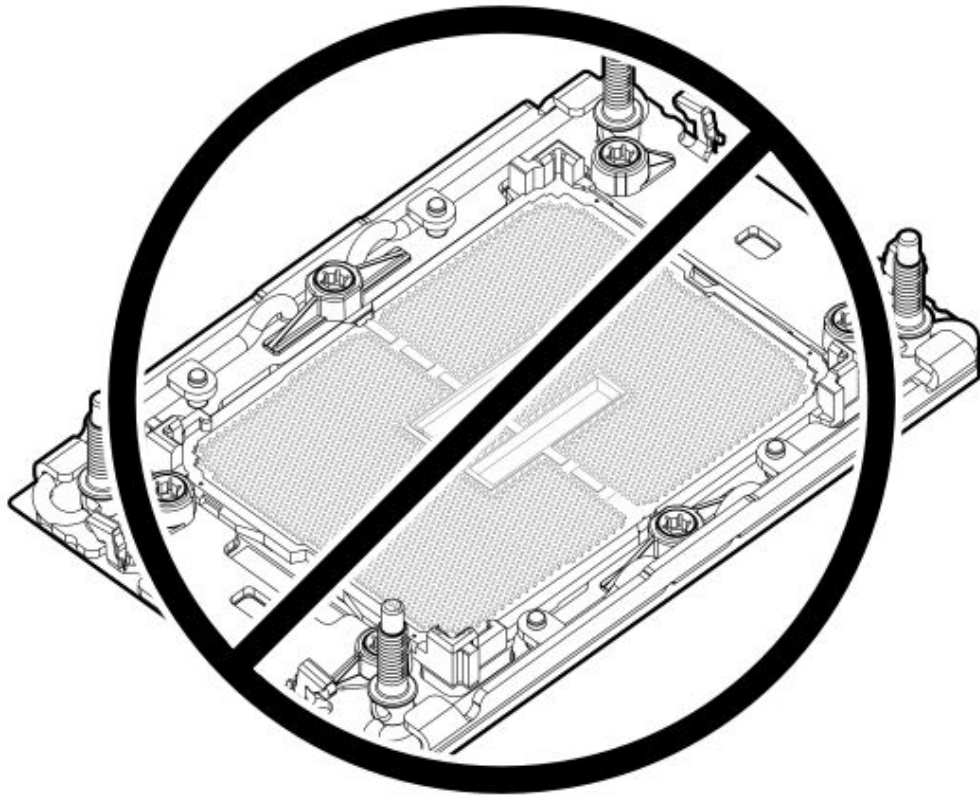

.8. Remove the processor from the heatsink:

a. Open the TIM breaker lever.

This action breaks the adhesion between the processor and the heatsink.

b. Hold the processor by its edges, and then remove it from the carrier.

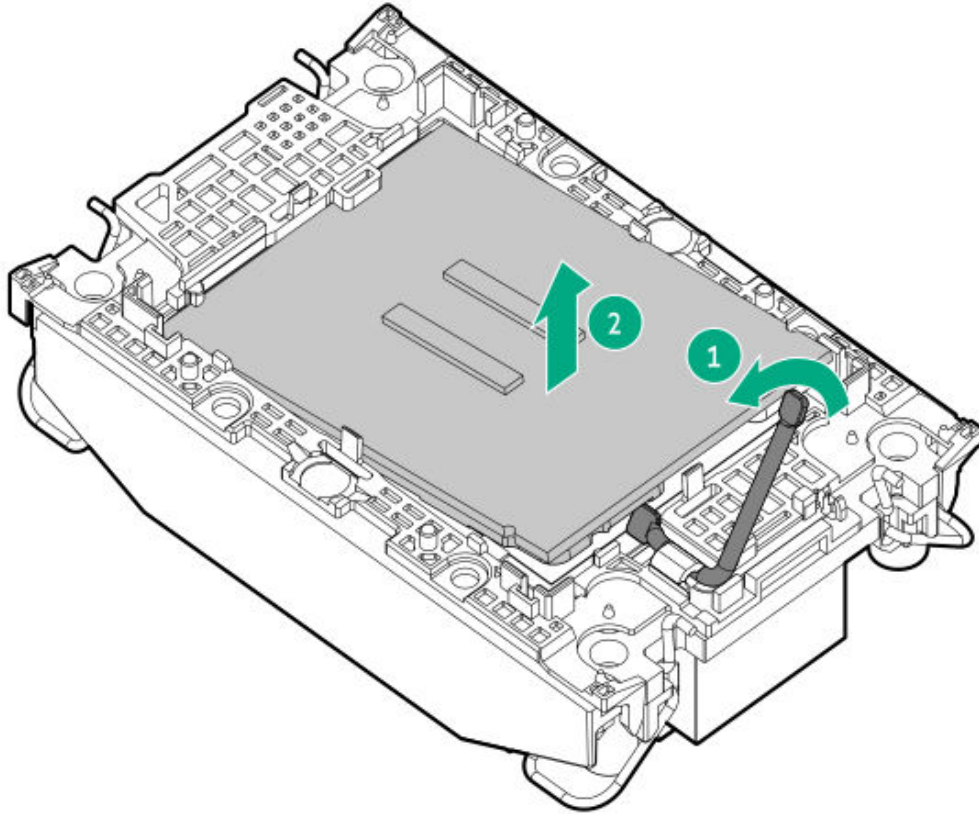

c. Starting from the pin 1 corner and moving in an opposite manner, disengage the processor carrier release tabs from the heatsink.

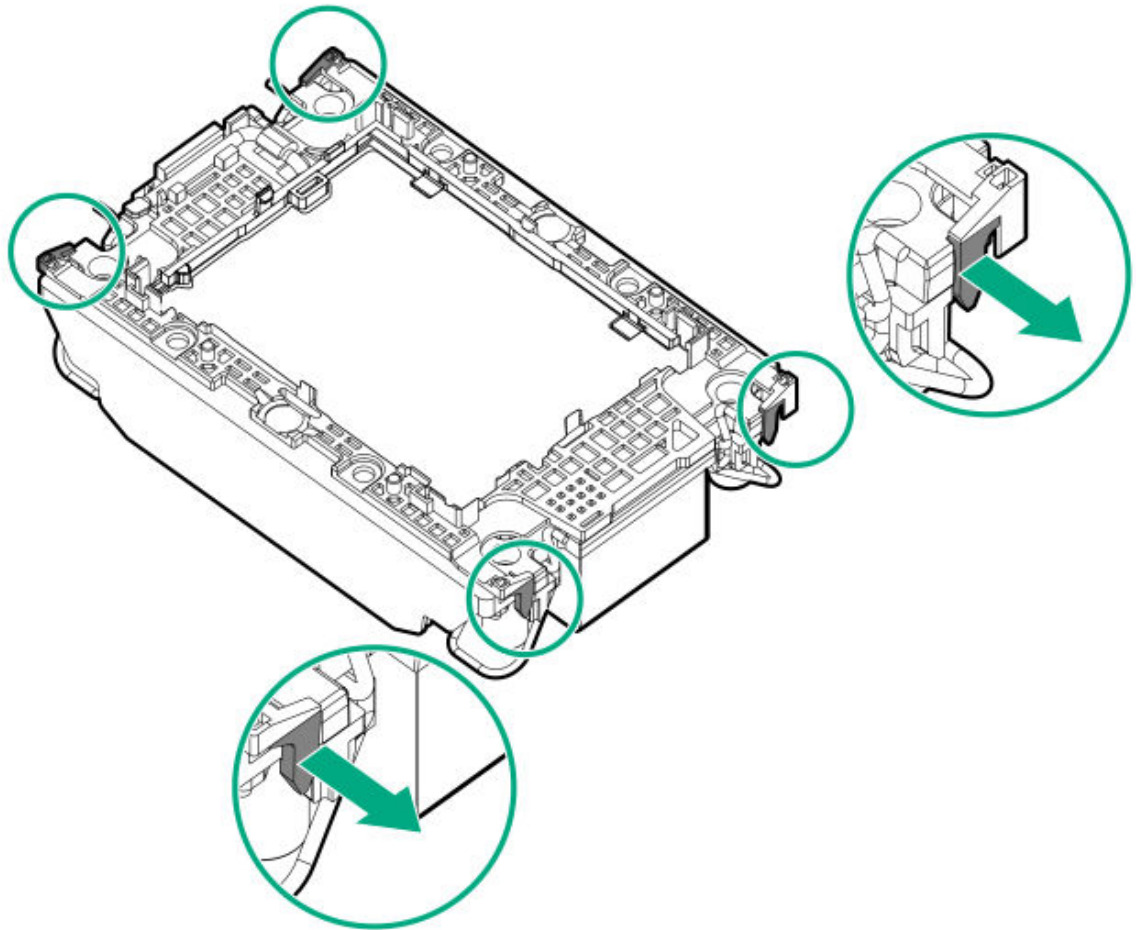

d. Lift the processor carrier away from the heatsink.

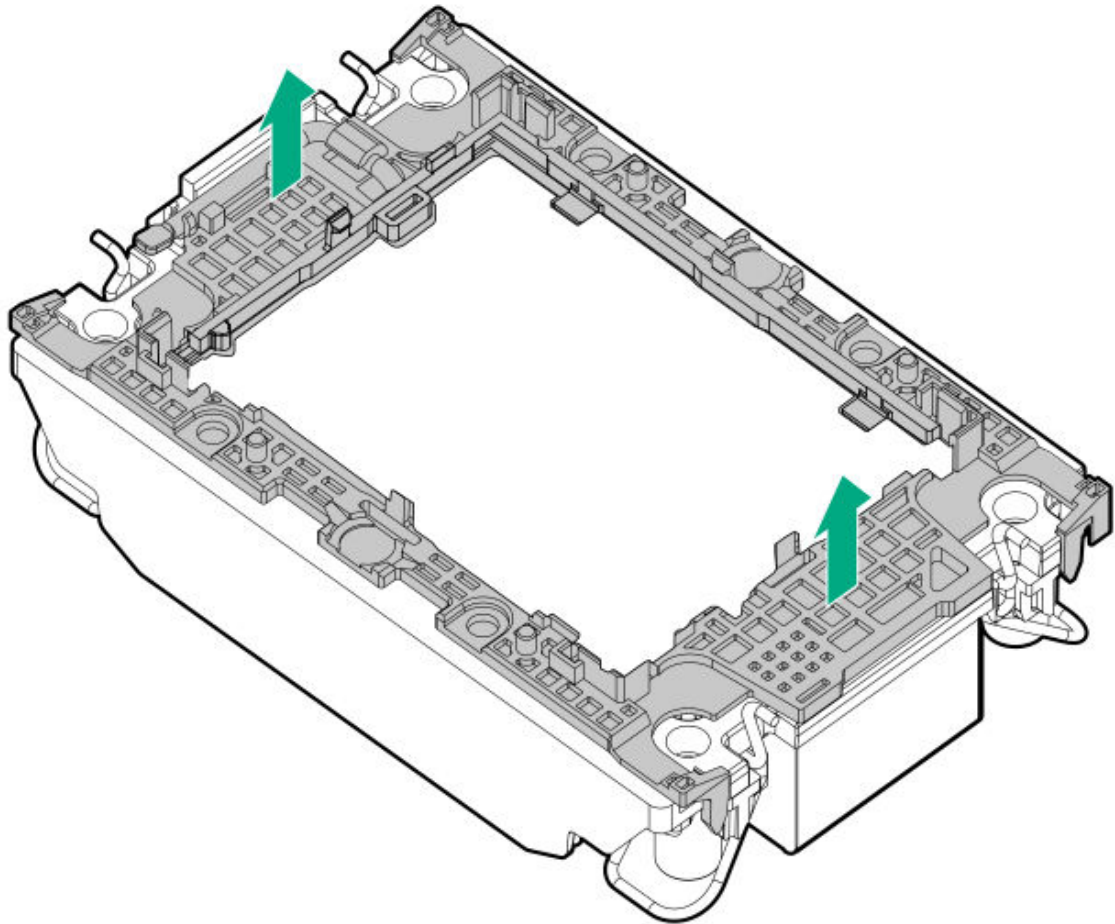

- .9. Use an alcohol wipe to remove the existing thermal grease from the heatsink and processor.
Allow the alcohol to evaporate before continuing.

Installing the heatsink

Prerequisites

- Identify the heatsink and processor socket components.
- Review the processor cautions.
- Before you perform this procedure, make sure that you have a torque screwdriver with T-30 Torx bit available.

About this task

Processors with TDP equal to or greater than 225 W require performance heatsinks.



CAUTION

A discharge of static electricity from a finger or other conductor might damage system boards or other static-sensitive devices. To prevent damage, observe antistatic precautions.

Procedure

1. Do not touch the pins on the processor socket and the processor.



CAUTION

THE PINS ON THE PROCESSOR SOCKET AND ON THE PROCESSOR ARE VERY FRAGILE AND EASILY DAMAGED. Any damage to them might require replacing the system board.

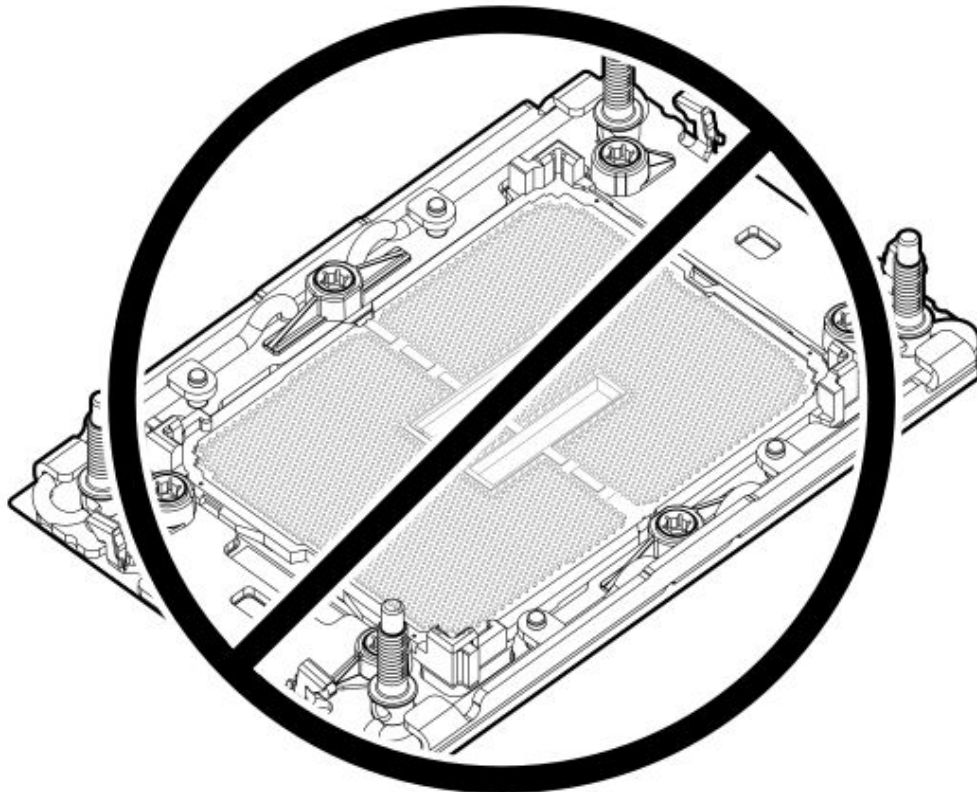

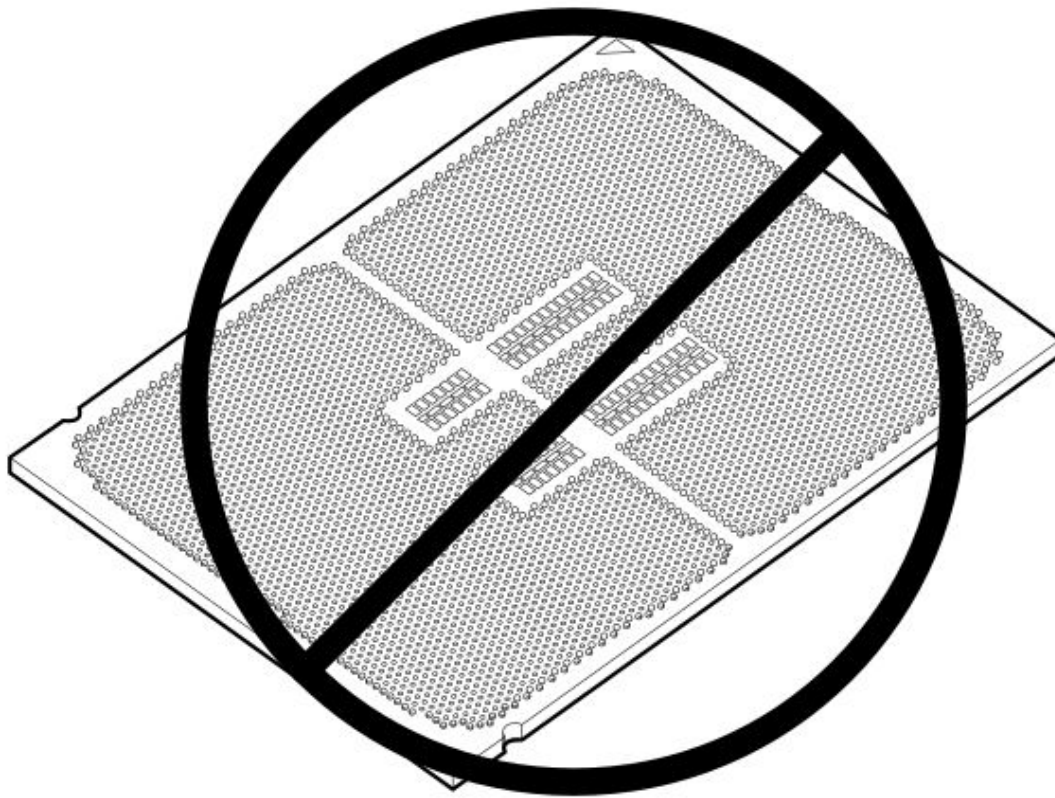

2. Install the processor carrier on the processor:

- a. Align the pin 1 indicator on the processor carrier with that on the processor, and then press on the pair of opposite sides on the TIM breaker lever of the processor carrier until it clicks into place.

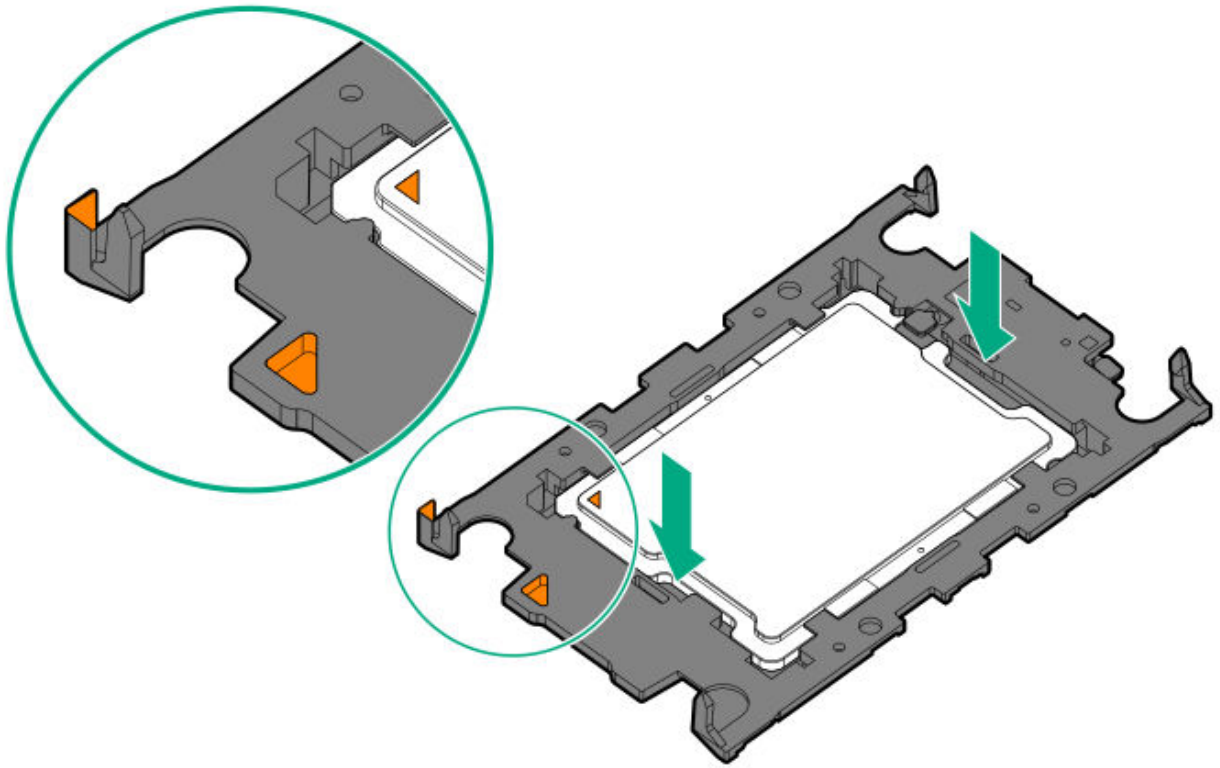

b. Verify that the processor is properly latched on the processor carrier.

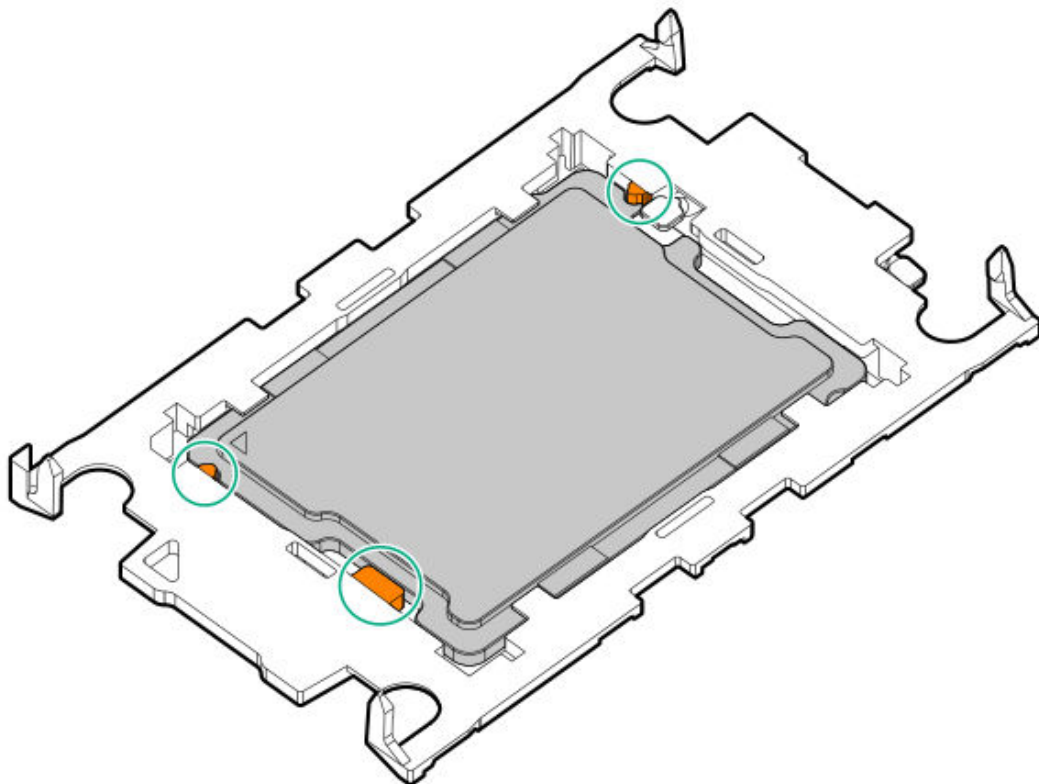

If not, press the other pair of opposite sides of the processor carrier until it clicks into place.

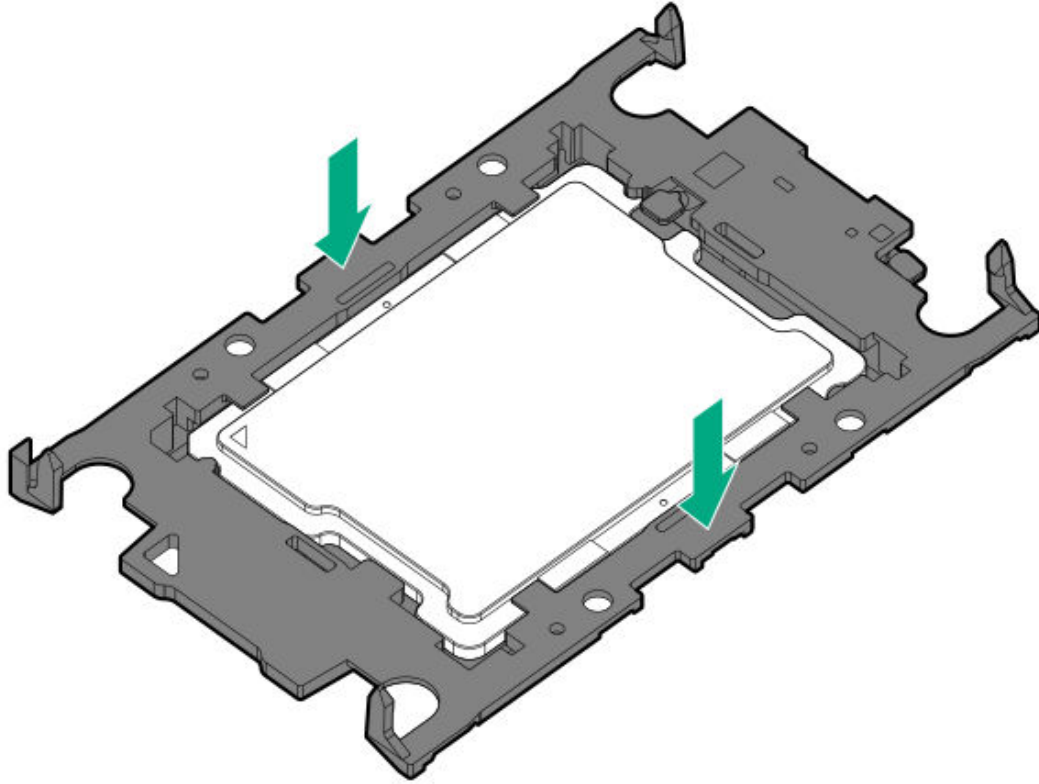

3. Remove the protective film from the thermal interface material.



CAUTION

To prevent mechanical damage or depositing oil on your hands or other contaminants to the heatsink contact surface, hold the heatsink only by the edge of its base plate. Do not touch the heatsink fins.

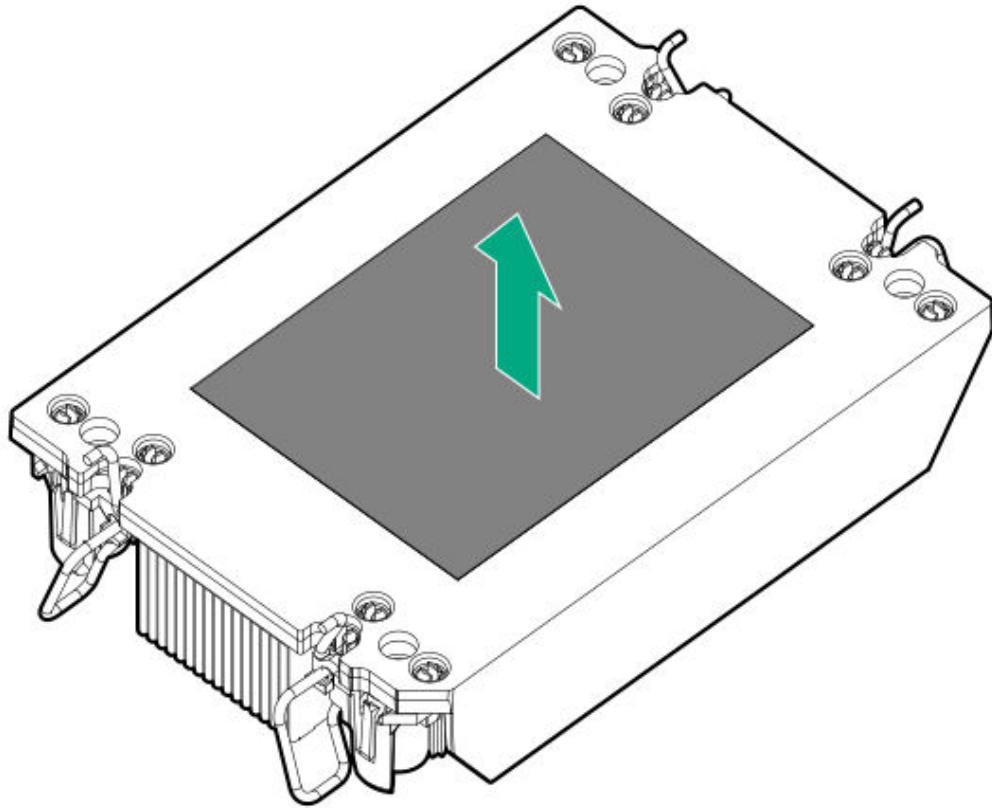

4. Set the anti-tilt wires to the locked position.

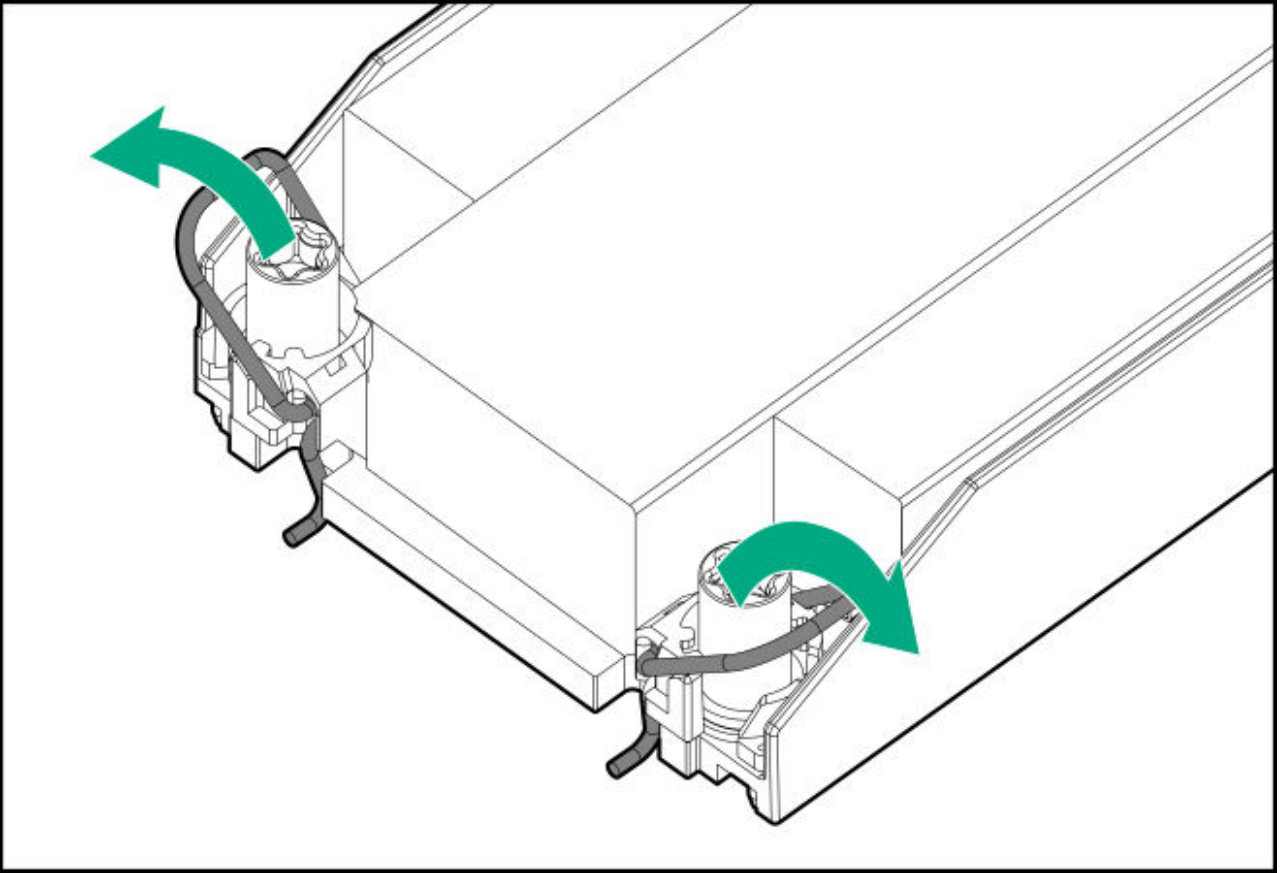

5. Attach the heatsink to the processor carrier:
 - a. Align the pin 1 indicator on the processor carrier with that on the heatsink.

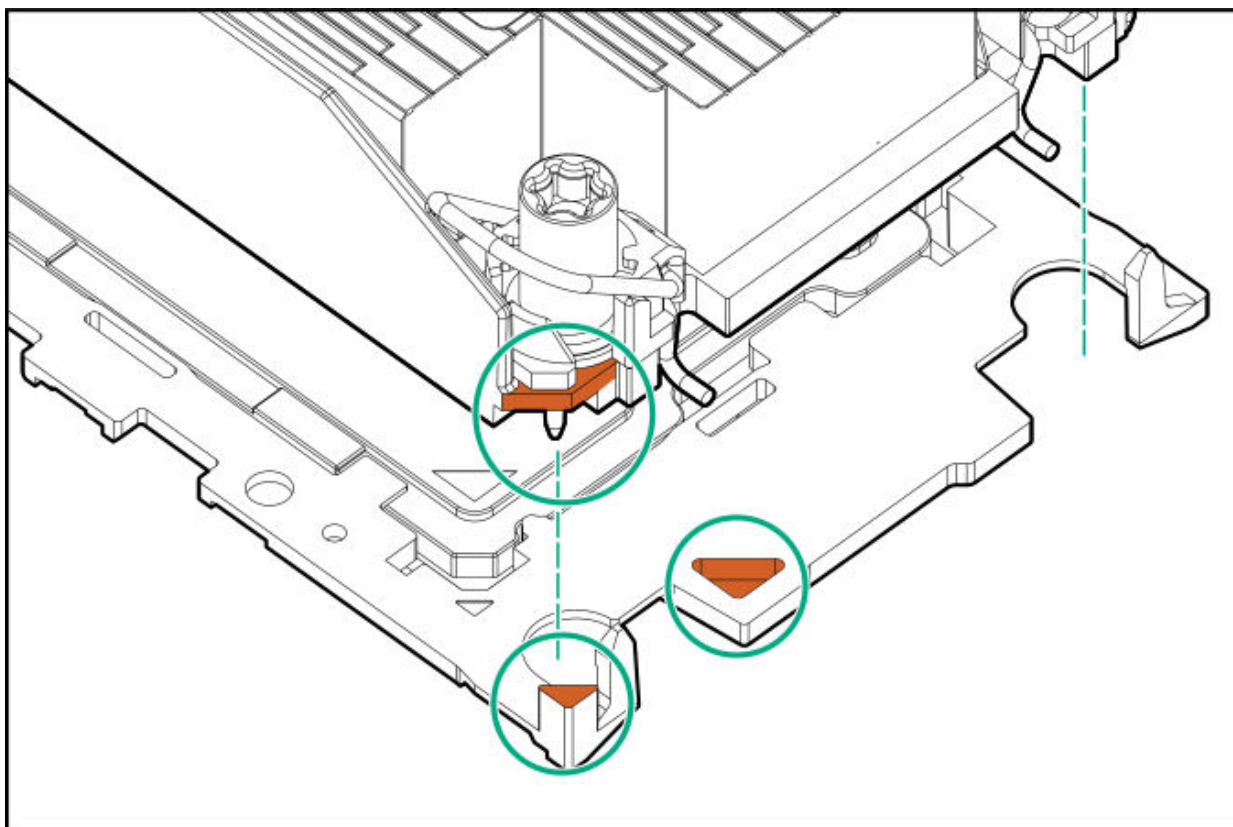

b. Lower the heatsink on the processor carrier until the carrier tabs snap into place.

There will be an audible click to indicate that the heatsink is properly latched on the processor carrier.

- Standard heatsink

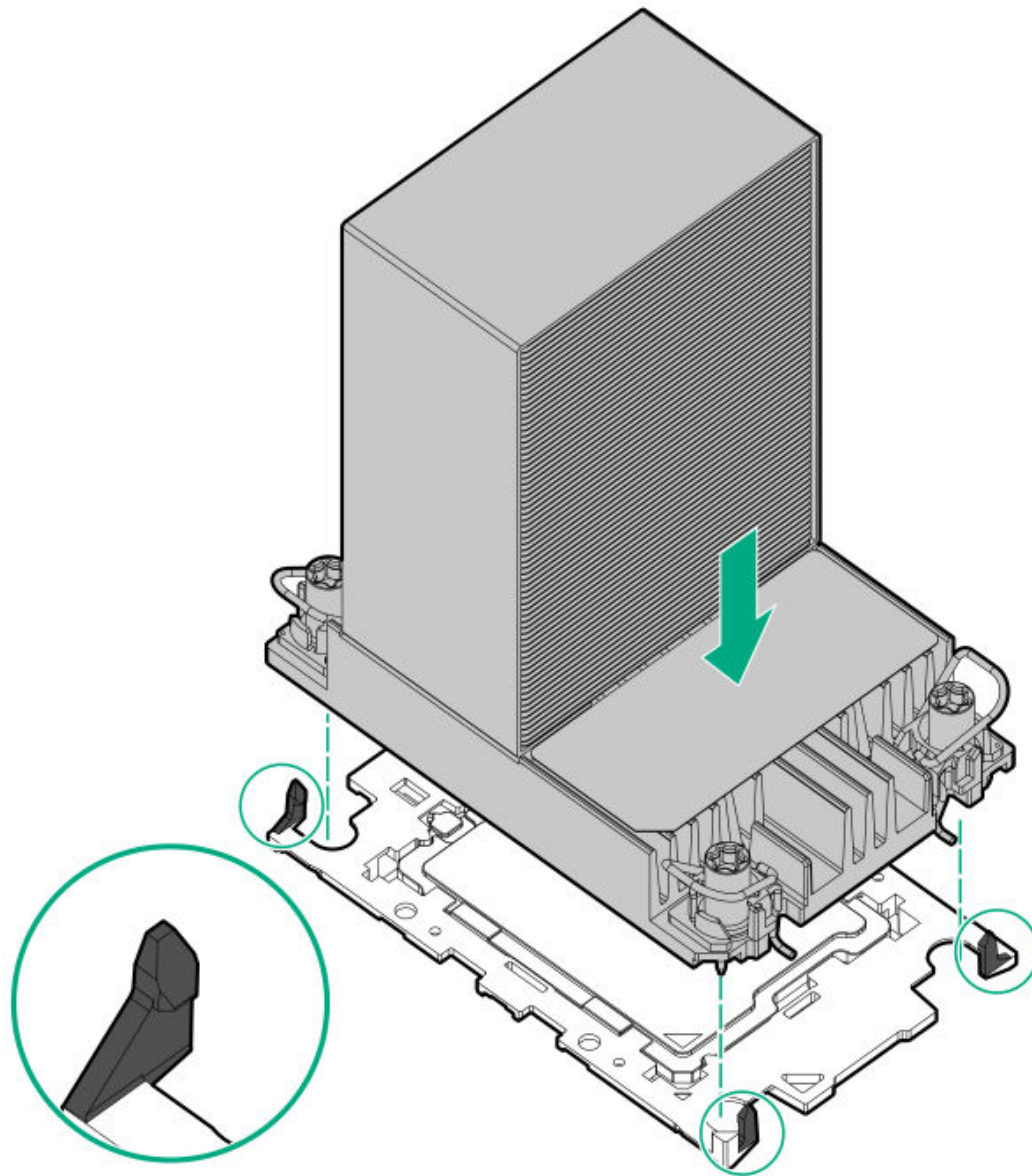

- Performance heatsink

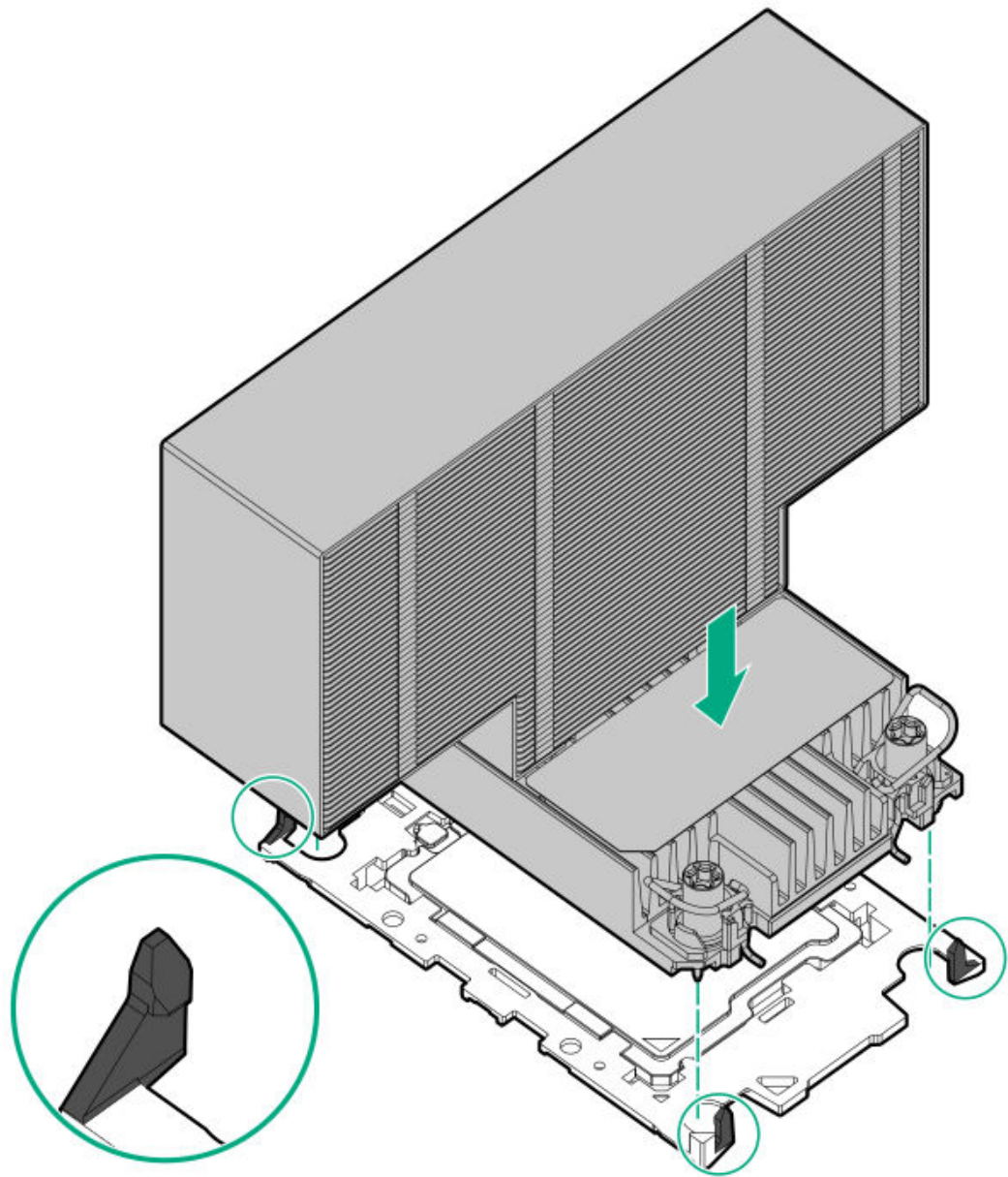

6. Perform the following verification steps:

- a. Verify that the tabs on the processor carrier are securely latched on the heatsink.

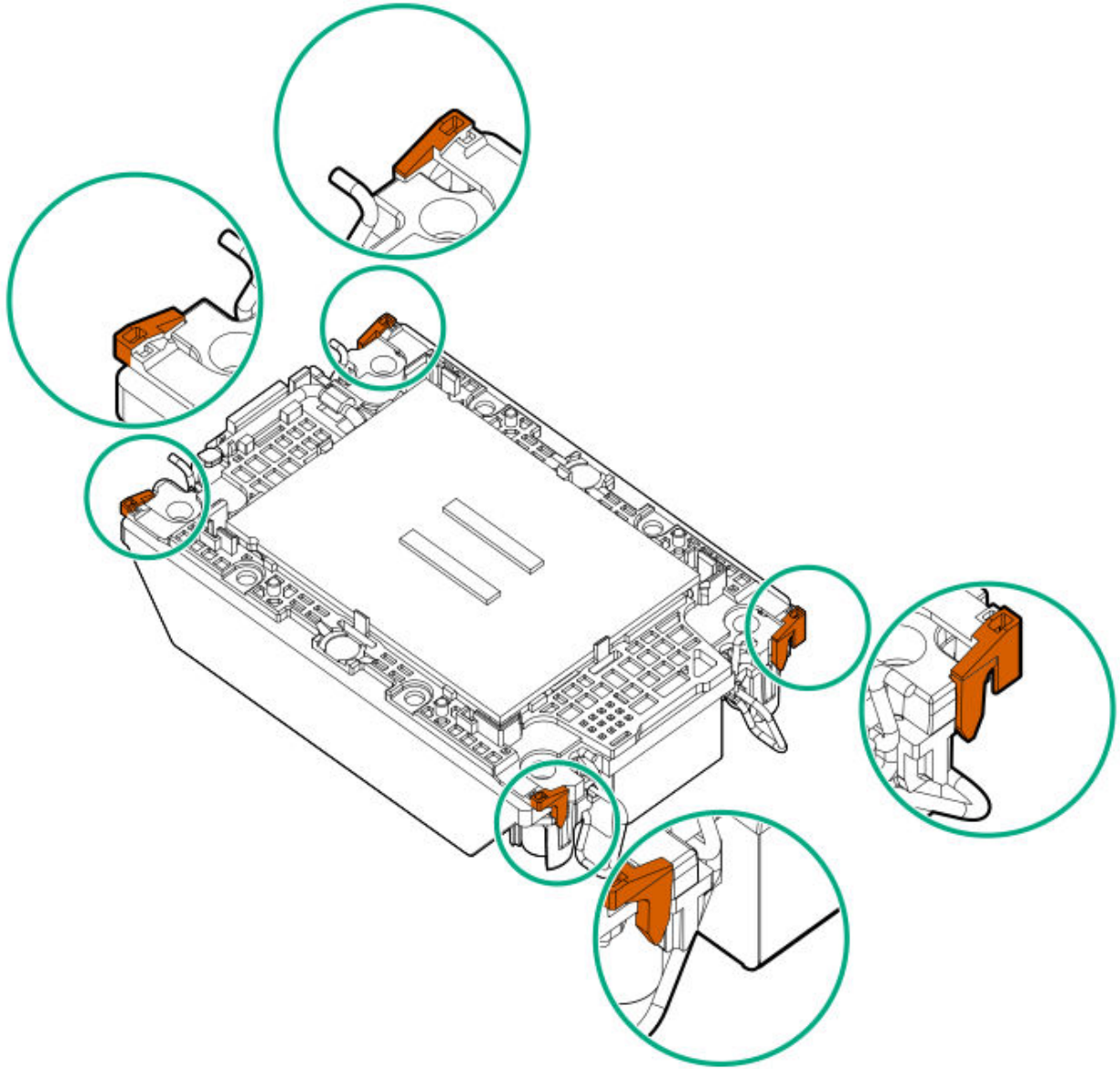

b. Verify that the pin 1 indicators on the processor and processor carrier are aligned.

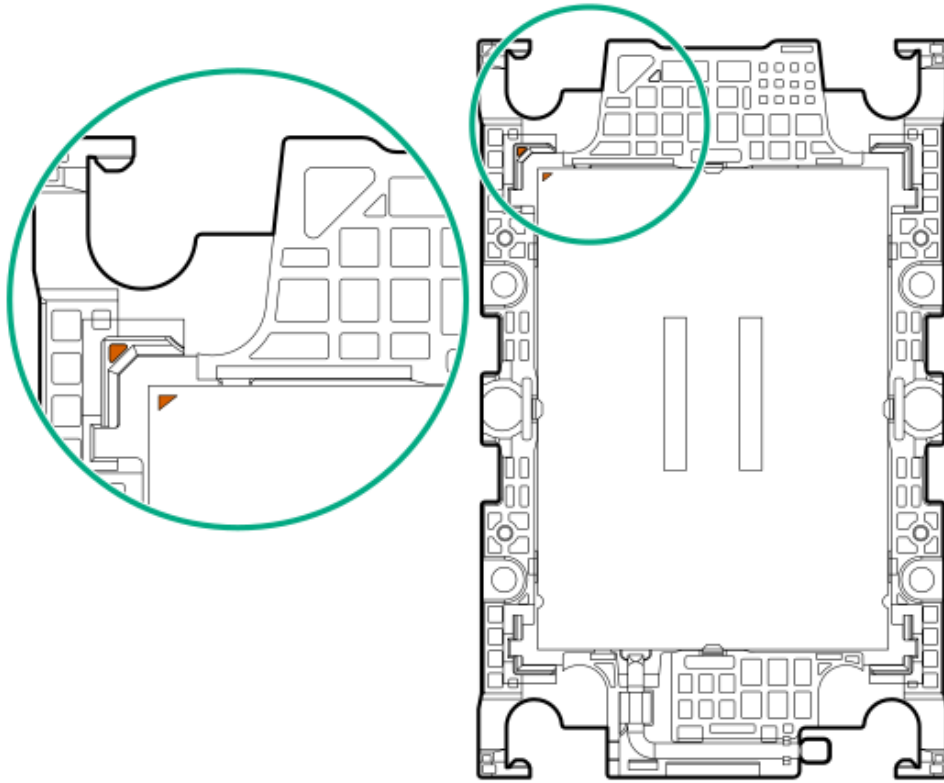

c. Verify that the processor is properly secured by the carrier snaps.

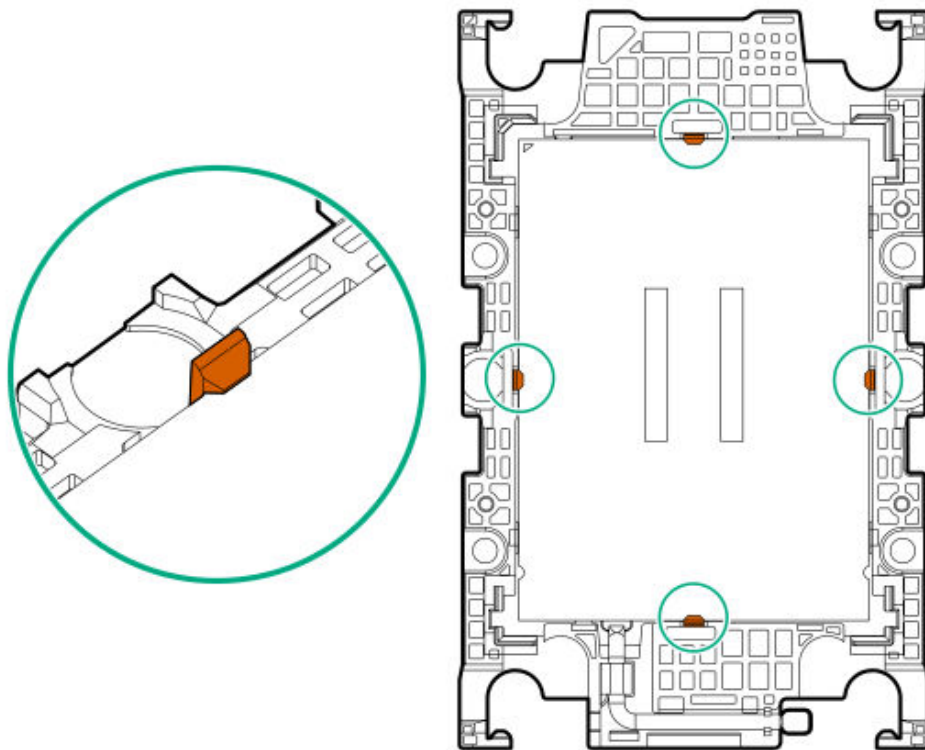

7.



CAUTION

To prevent thermal failure or component damage, do not move the heatsink once the bottom of its base plate touches the top of the processor. Excessive heatsink movement can cause the thermal grease to smear and become uneven. Voids in the compound can adversely impact the transfer of heat away from the processor.

Install the processor-heatsink module:

- a. When using a torque wrench to tighten the heatsink screws, set 0.9 N-m (8 in-lb) of torque.
- b. Note the **Front of server** text on the heatsink label to correctly orient the processor-heatsink module over the bolster plate.
- c. Carefully lower the processor-heatsink module straight down onto the bolster plate guide posts.

The posts are keyed so that the module can only be installed one way. Make sure that the module is properly seated on the bolster plate before securing the screws.

- Standard heatsink

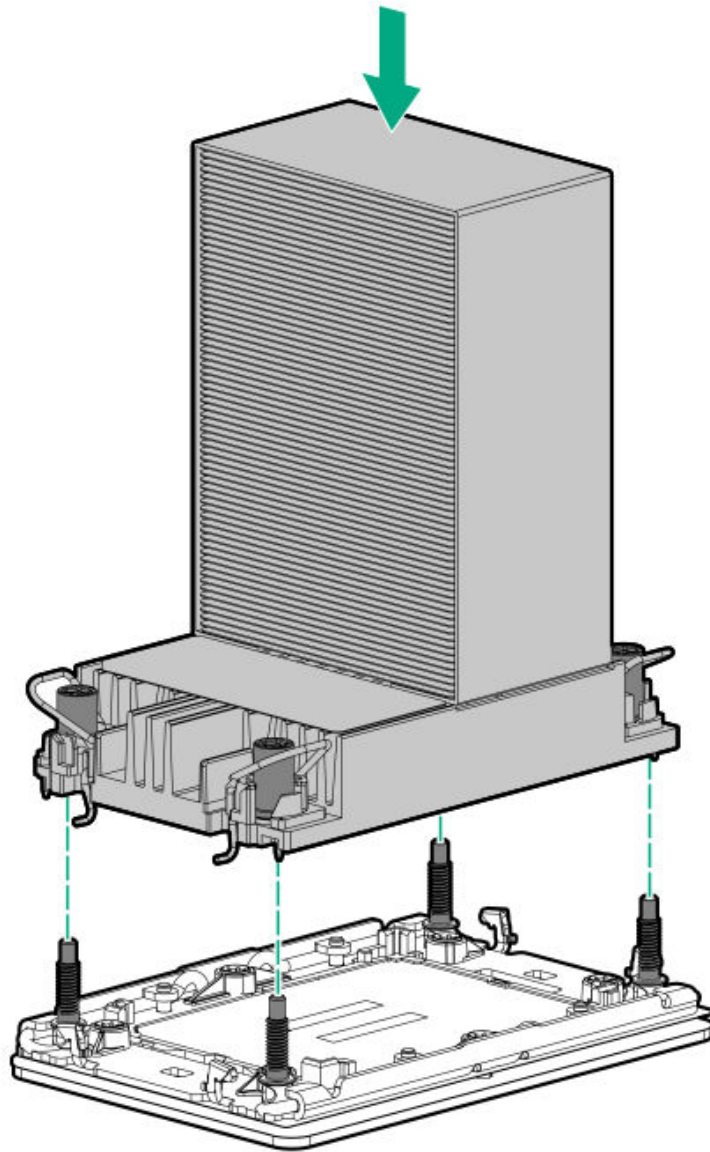

- Performance heatsink

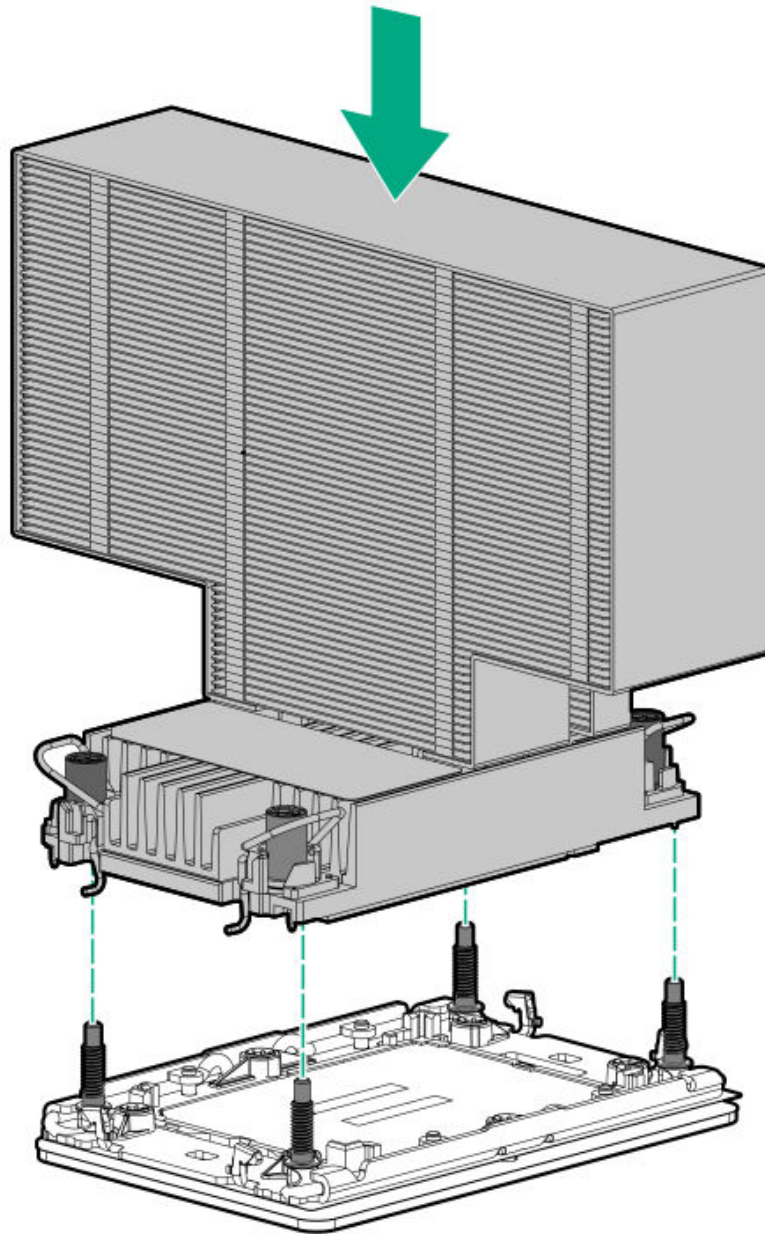

d. Set the anti-tilt wires to the locked position.

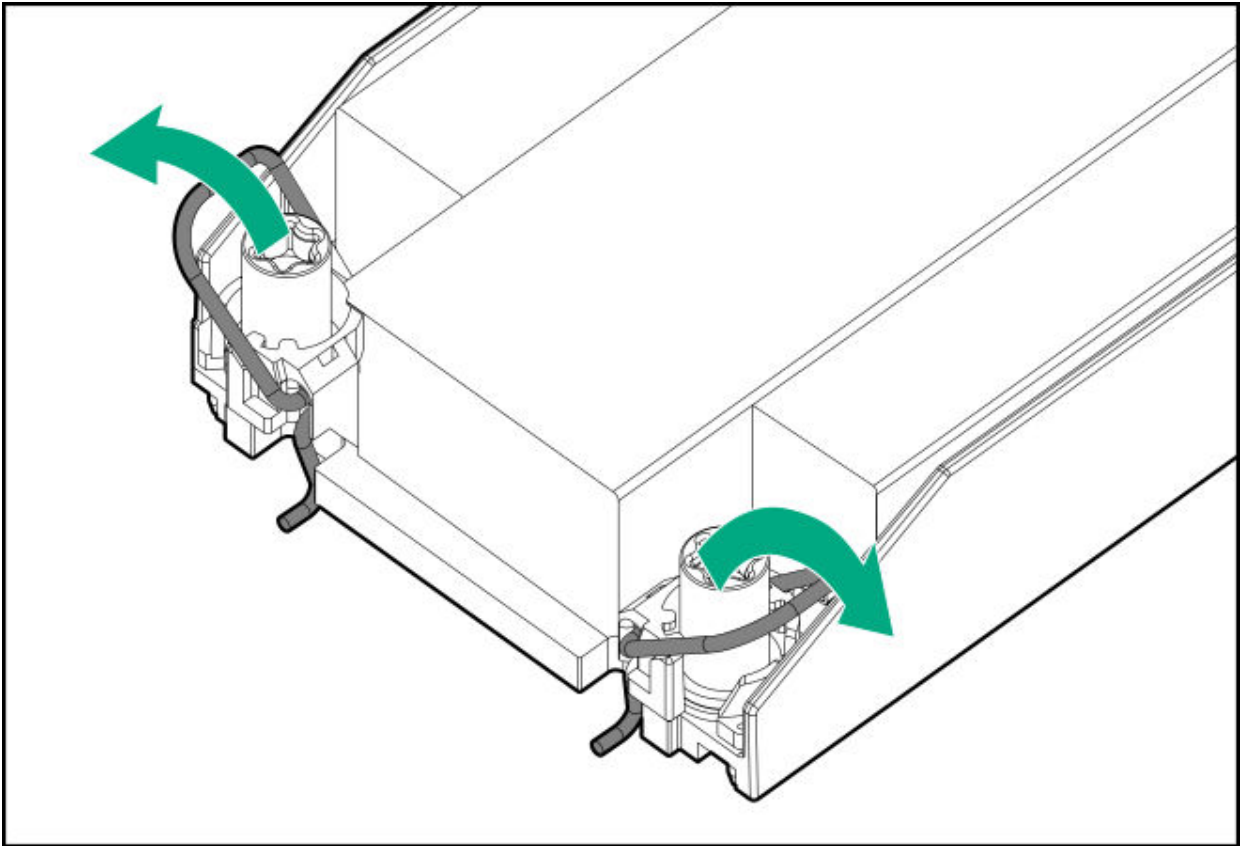

e. Tighten one pair of diagonally opposite heatsink screws, and then tighten the other pair of heatsink screws.

- Standard heatsink

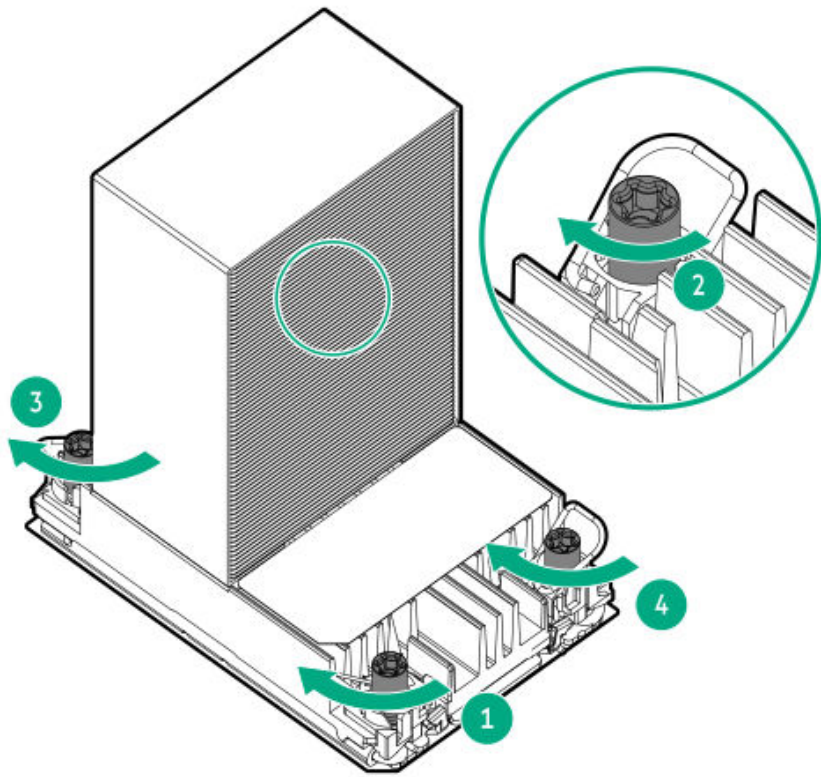

- Performance heatsink

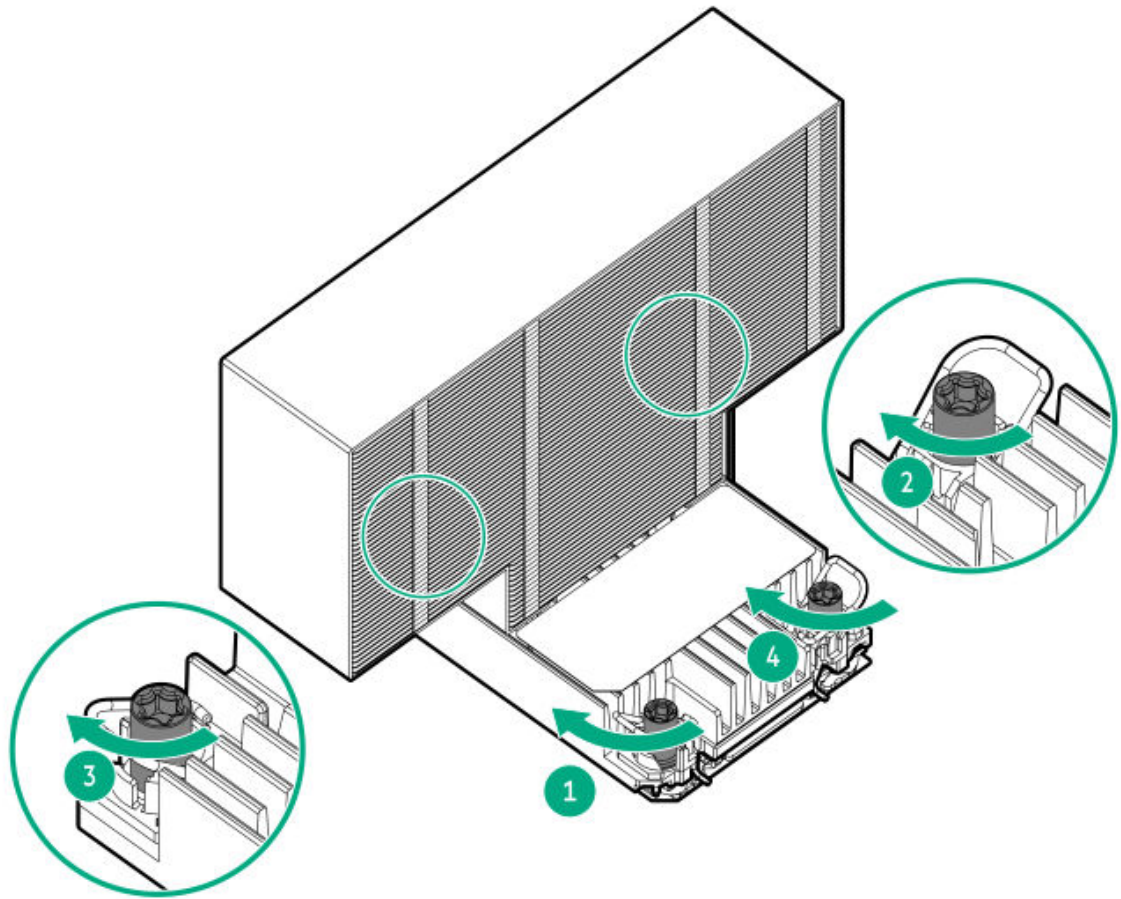

8. Install the riser cages.
9. Install the fan cage.
0. Install the access panel.
1. Lock the front bezel.
2. Do one of the following:
 - Orient the server back in tower mode.
 - Install the server into the rack.
3. Connect all peripheral cables to the server.
4. Connect each power cord to the server.
5. Connect each power cord to the power source.
6. Power up the server.

Results

The replacement procedure is complete.

Processor replacement

Subtopics

Processor cautions

Removing the processor

Installing the processor

Processor cautions



CAUTION

To avoid damage to the processor or system board, only authorized personnel should attempt to replace or install the processor in this server.



CAUTION

To prevent possible server malfunction and damage to the equipment, multiprocessor configurations must contain processors with the same part number.



CAUTION

The pins on the processor socket and on the processor are very fragile and easily damaged. To avoid component damage, **do not touch these pins.** Any damage to them might require replacing the system board and/or processor.



IMPORTANT

Processor socket 1 must be populated at all times or the server does not function.



IMPORTANT

If installing a processor with a faster speed, update the system ROM before installing the processor. To download firmware, see [Updating firmware or system ROM](#).

Removing the processor

Prerequisites

- [Identify the heatsink and processor socket components.](#)
- [Review the processor cautions.](#)
- Before you perform this procedure, make sure that you have the following items available:
 - T-30 Torx screwdriver
 - Alcohol wipe
- If you are not immediately installing the replacement processor-heatsink assembly, make sure that you have a processor socket dust cover.

About this task



WARNING

To reduce the risk of personal injury from hot surfaces, allow the drives and the internal system components to cool before touching them.



CAUTION

A discharge of static electricity from a finger or other conductor might damage system boards or other static-sensitive devices. To prevent damage, observe [antistatic precautions](#).

Procedure

1. [Power down the server.](#)
2. Remove all power:
 - a. Disconnect each power cord from the power source.
 - b. Disconnect each power cord from the server.
3. Disconnect all peripheral cables from the server.
4. If the server is in tower mode, [place the server on a flat, level surface with the access panel facing up.](#)
5. If the server is in rack mode, do one of the following, [remove the server from the rack.](#)
6. Unlock the front bezel.

7. Remove the access panel.
8. Do the following:
 - Remove the primary riser cage.
 - Remove the secondary riser cage.
9. Remove the fan cage.
10. Allow all internal system components to cool before continuing.
11. Loosen one pair of diagonally opposite screws, and then loosen the other pair of screws.



CAUTION

Heatsink screws must be tightened and loosened in alternating sequence. Do not overtighten the screws as this might damage the system board or the processor socket.

- Standard heatsink

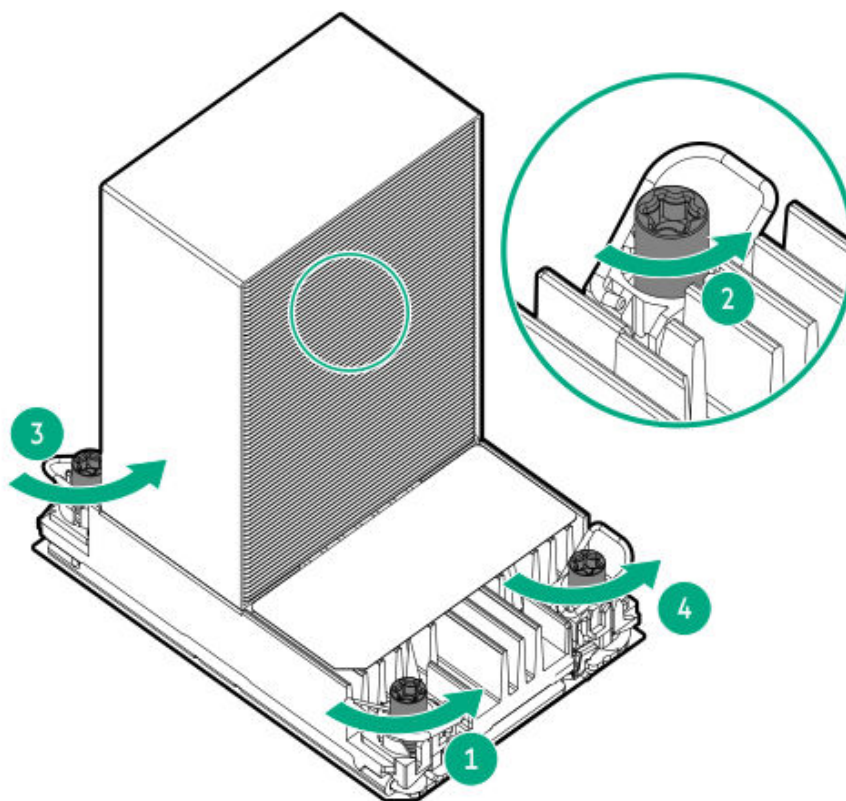

- Performance heatsink

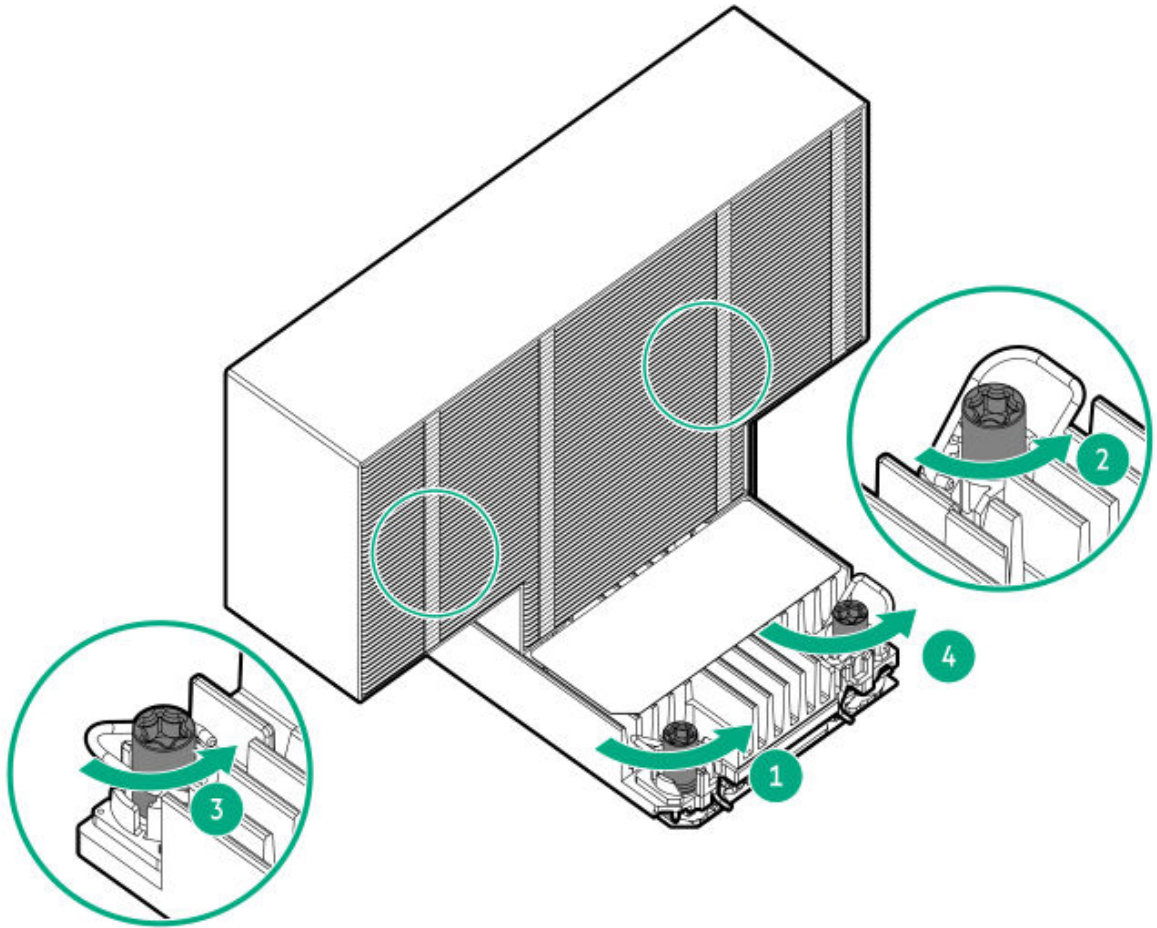

.2. Set the anti-tilt wires to the unlocked position.

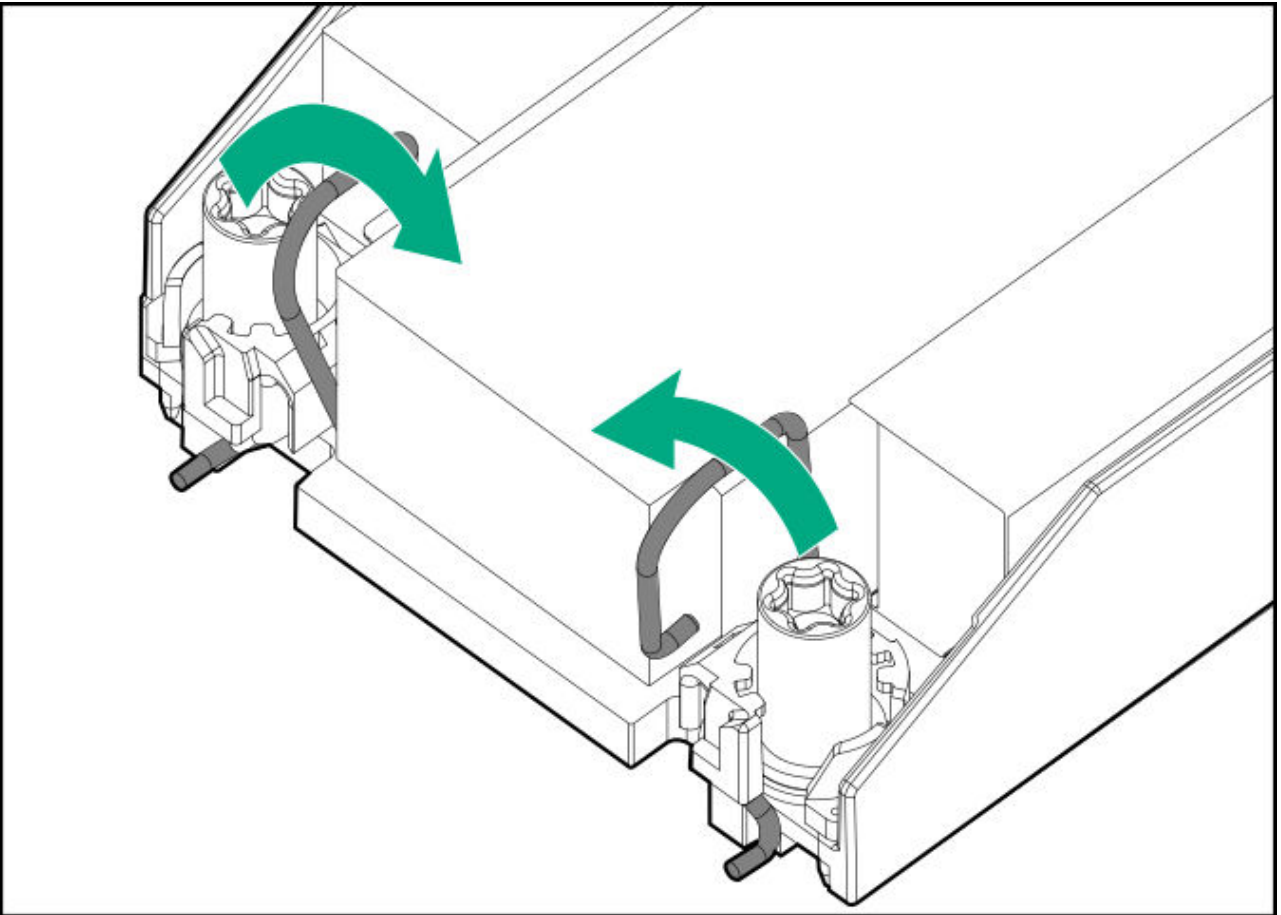

.3. Lift the processor-heatsink module straight up from the system board.



CAUTION

To prevent mechanical damage or depositing oil on your hands or other contaminants to the heatsink contact surface, hold the heatsink only by the edge of its base plate. Do not touch the heatsink fins.

- Standard heatsink

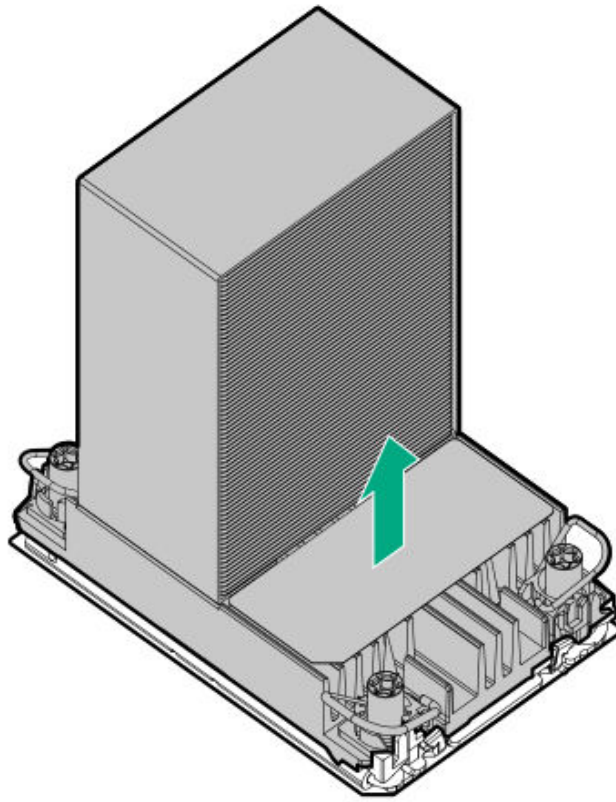

- Performance heatsink

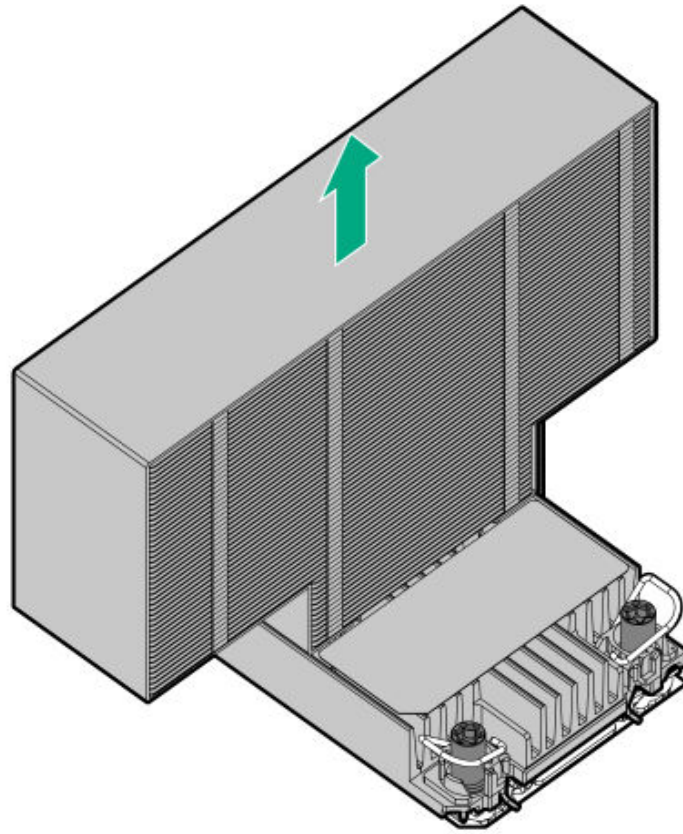

4. Set the anti-tilt wires to the locked position.

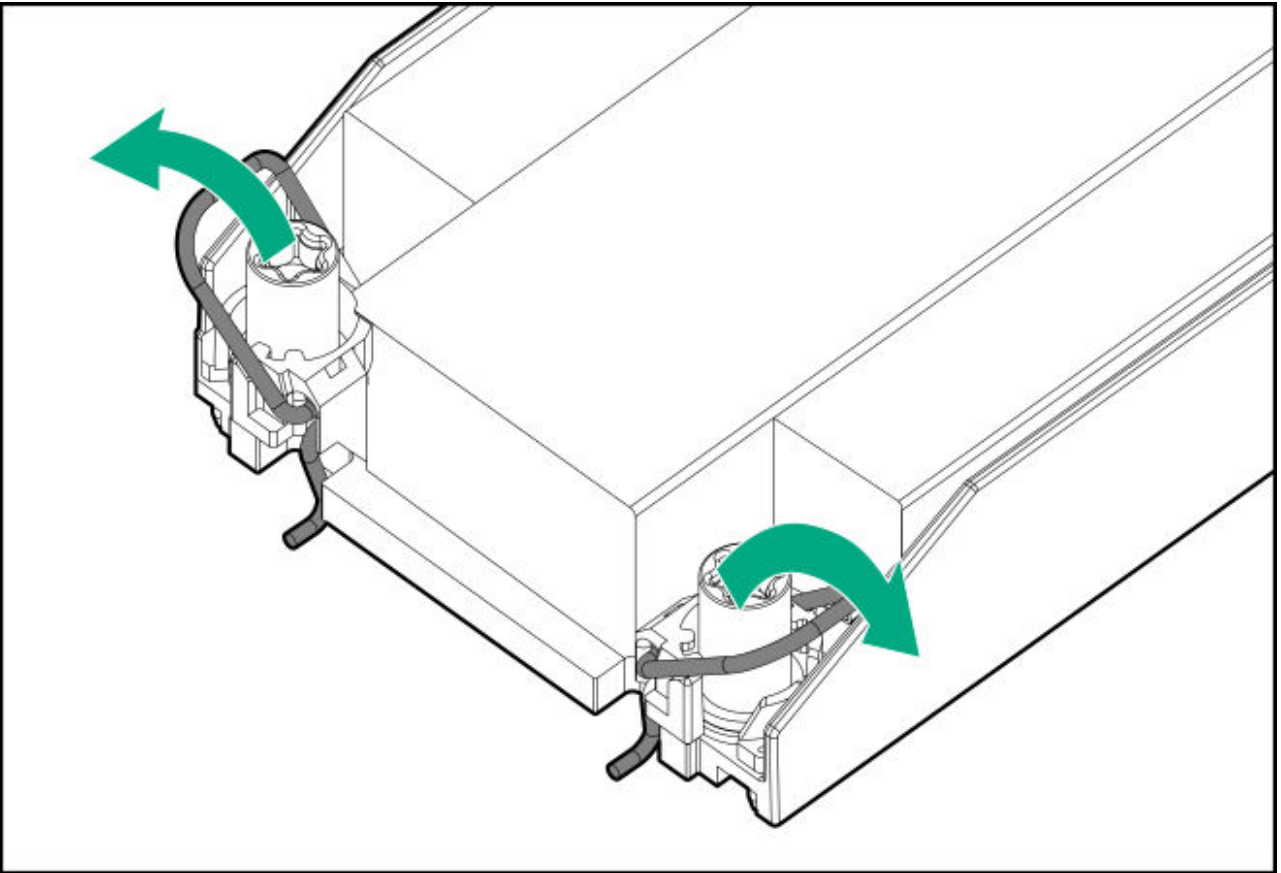

- .5. Place the processor-heatsink module on a flat work surface with its contact side facing up.
- .6. If you are not immediately installing the replacement processor-heatsink module, install the dust cover on the empty processor socket:



CAUTION

Do not press down on the dust cover. Pressing down on the dust cover might damage the processor socket.

- a. Press and hold the grip tabs on the dust cover.
- b. Carefully lower the dust cover onto the bolster plate guide posts.

Make sure that the corner holes of the dust cover are properly engaged with the guide posts on the bolster plate.

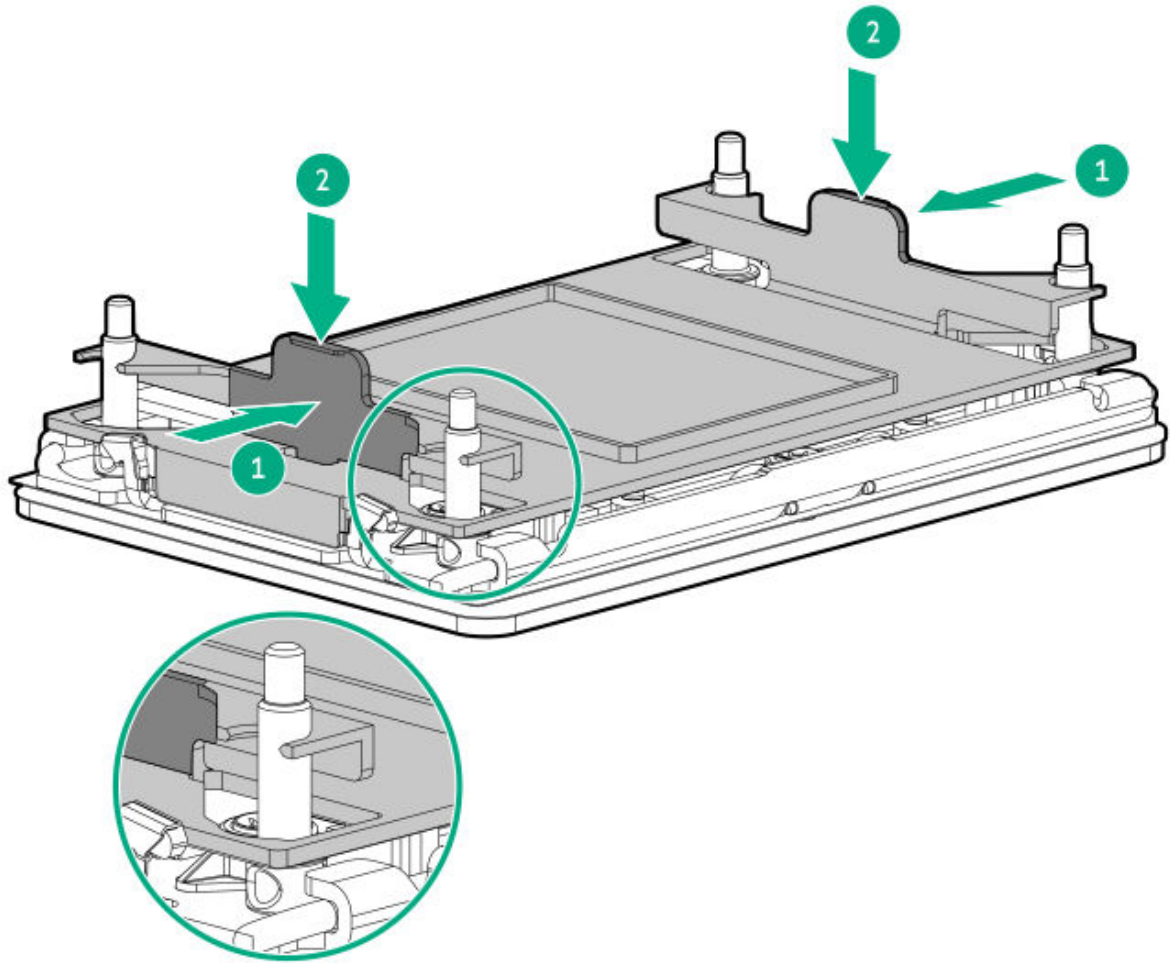

.7. Do not touch the pins on the processor socket and the processor.



CAUTION

THE PINS ON THE PROCESSOR SOCKET AND ON THE PROCESSOR ARE VERY FRAGILE AND EASILY DAMAGED. Any damage to them might require replacing the system board.

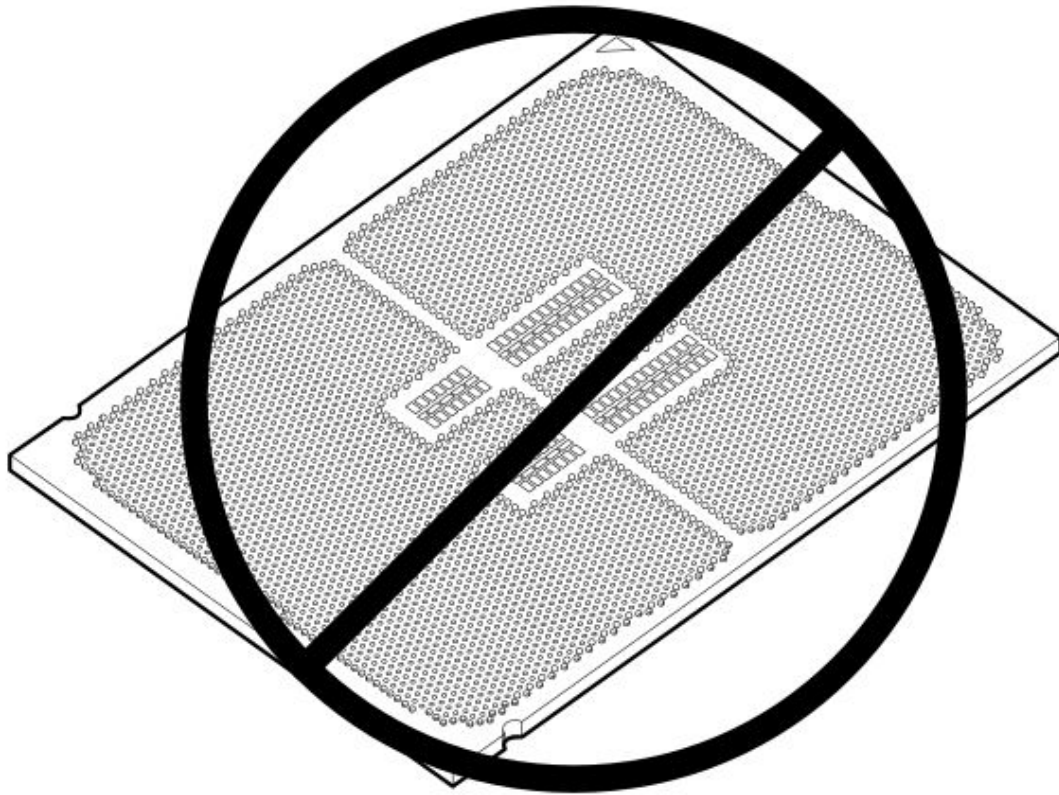
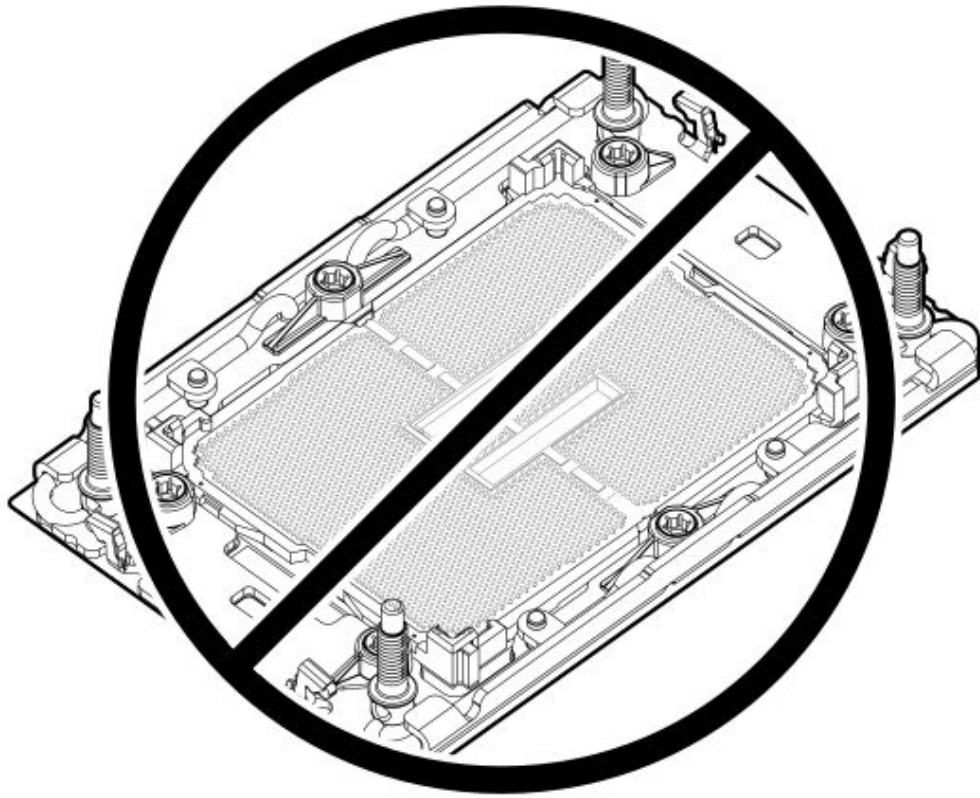

.8. Remove the processor from the heatsink:

a. Open the TIM breaker lever.

This action breaks the adhesion between the processor and the heatsink.

b. Hold the processor by its edges, and then remove it from the carrier.

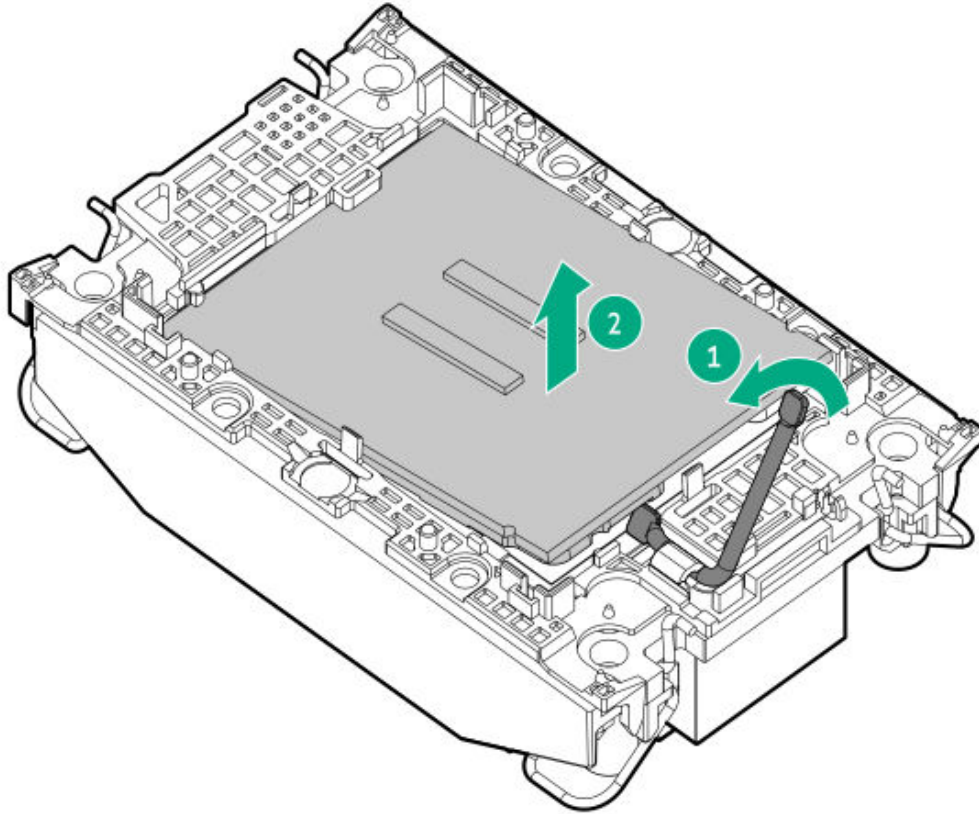

c. Starting from the pin 1 corner and moving in an opposite manner, disengage the processor carrier release tabs from the heatsink.

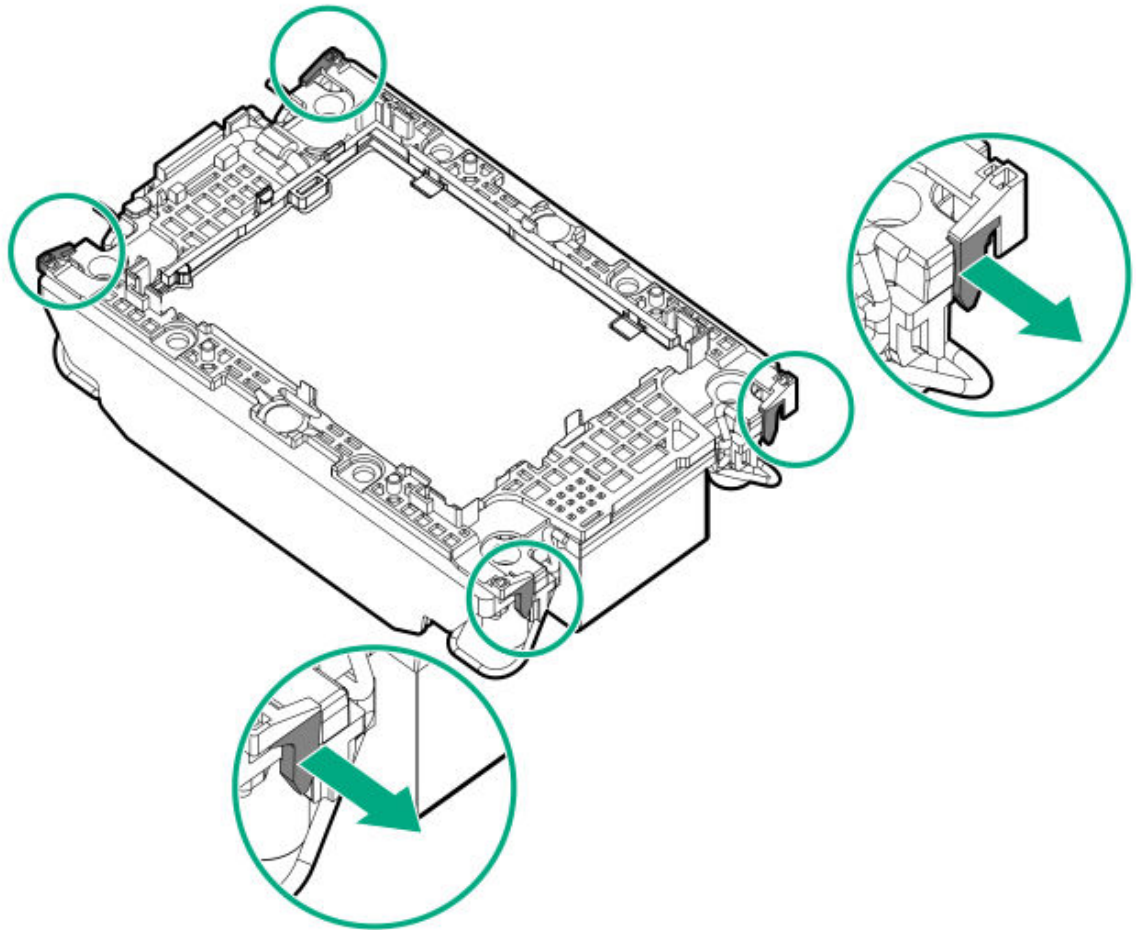

d. Lift the processor carrier away from the heatsink.

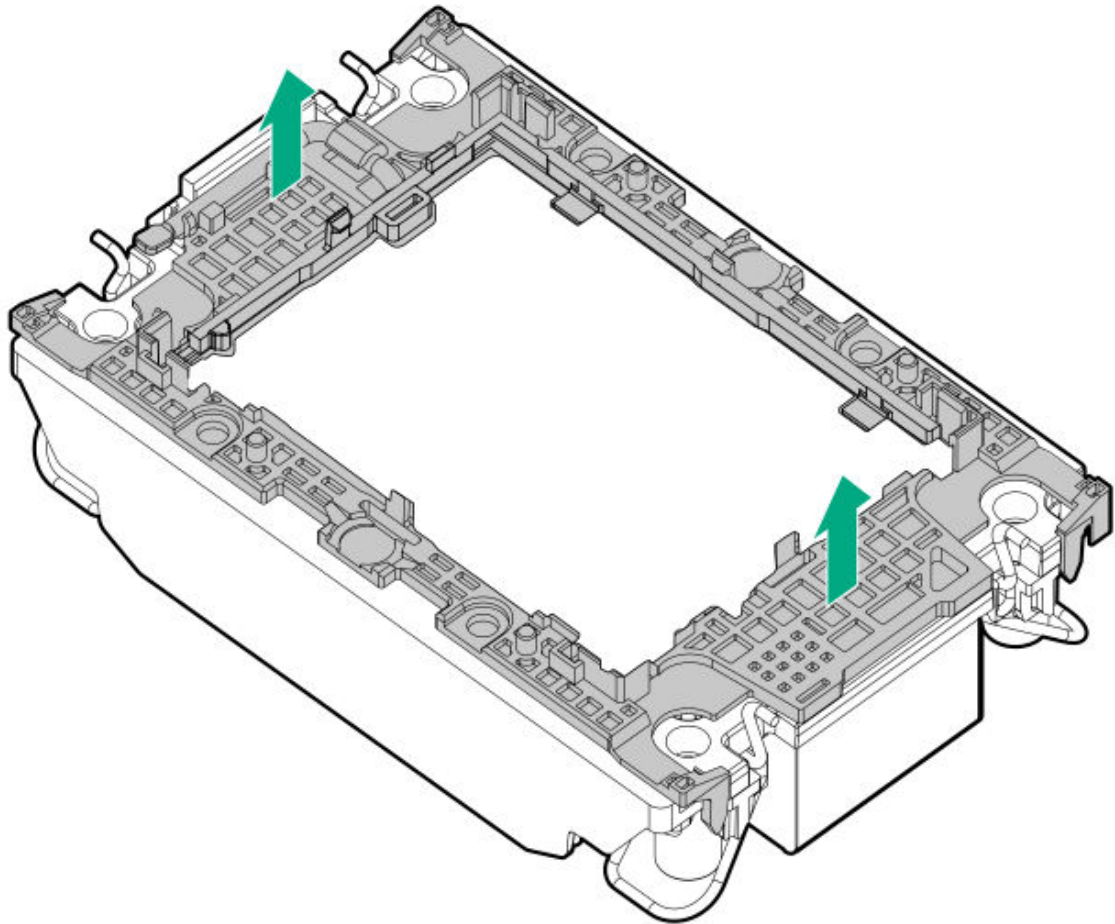

- .9. Use an alcohol wipe to remove the existing thermal grease from the heatsink and processor.
Allow the alcohol to evaporate before continuing.

Installing the processor

Prerequisites

- Identify the heatsink and processor socket components.
- Review the processor cautions.
- Before you perform this procedure, make sure that you have the following items available:
 - Torque screwdriver with T-30 Torx bit
 - Two 1.0 gm (0.5 ml) of thermal grease

About this task

Processors with TDP equal to or greater than 225 W require performance heatsinks.



CAUTION

A discharge of static electricity from a finger or other conductor might damage system boards or other static-sensitive devices. To prevent damage, observe antistatic precautions.

Procedure

1. If you are using the same heatsink, apply the full content of the thermal grease syringes on top of the processor. Follow the pattern shown in the following image.

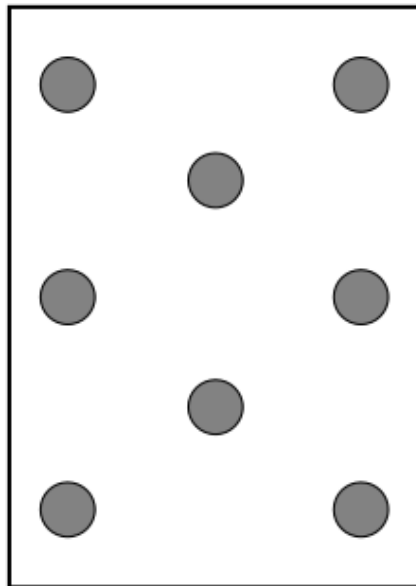

2. If you are using a new heatsink, remove the protective film from the thermal interface material.



CAUTION

To prevent mechanical damage or depositing oil on your hands or other contaminants to the heatsink contact surface, hold the heatsink only by the edge of its base plate. Do not touch the heatsink fins.

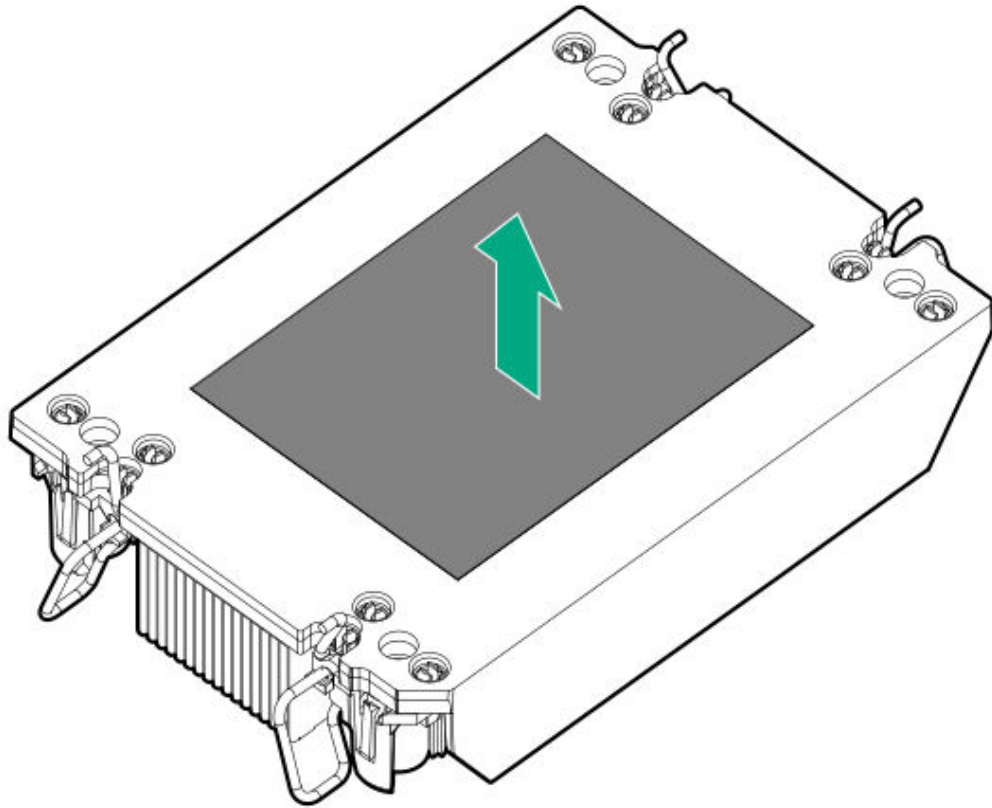

3. Set the anti-tilt wires to the locked position.

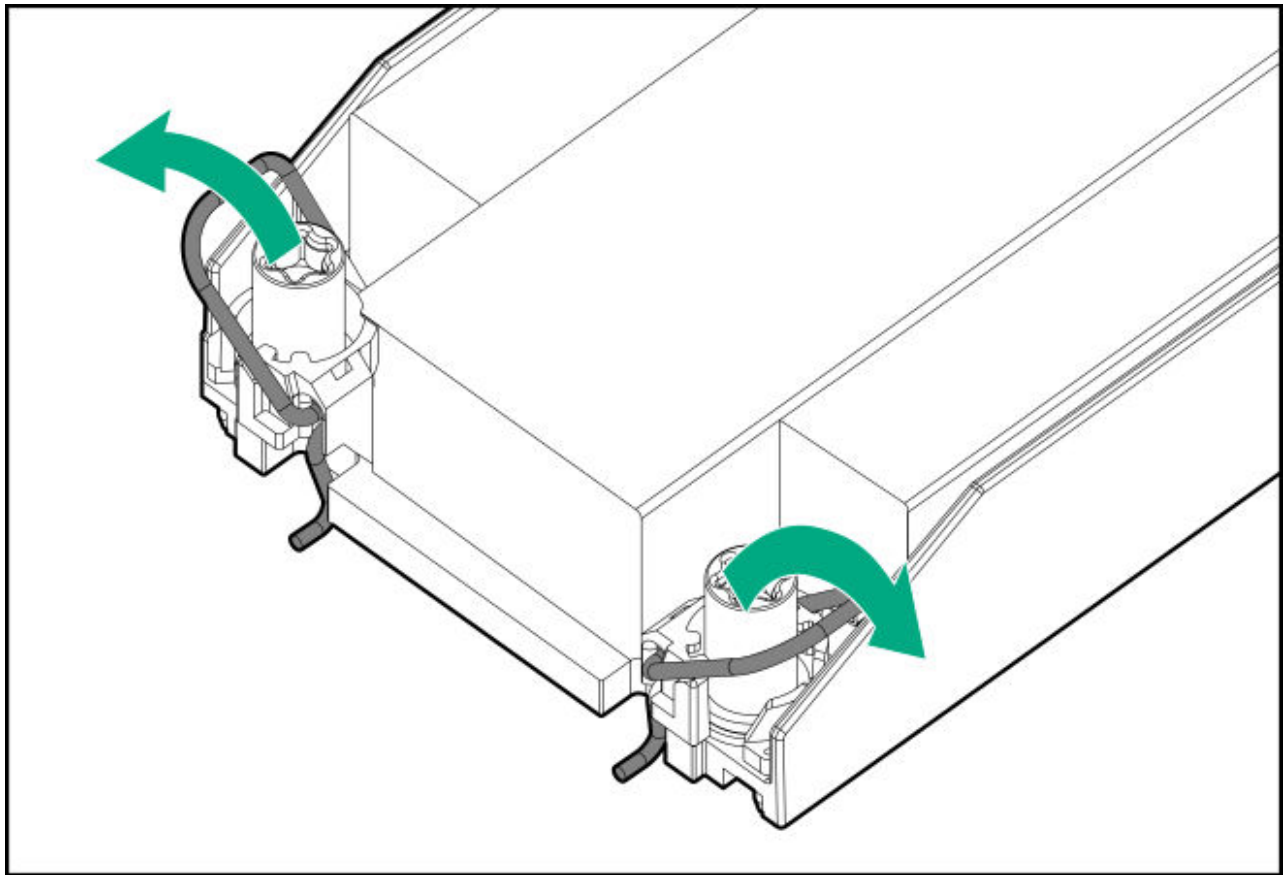

4. Do not touch the pins on the processor socket and the processor.



CAUTION

THE PINS ON THE PROCESSOR SOCKET AND ON THE PROCESSOR ARE VERY FRAGILE AND EASILY DAMAGED. Any damage to them might require replacing the system board.

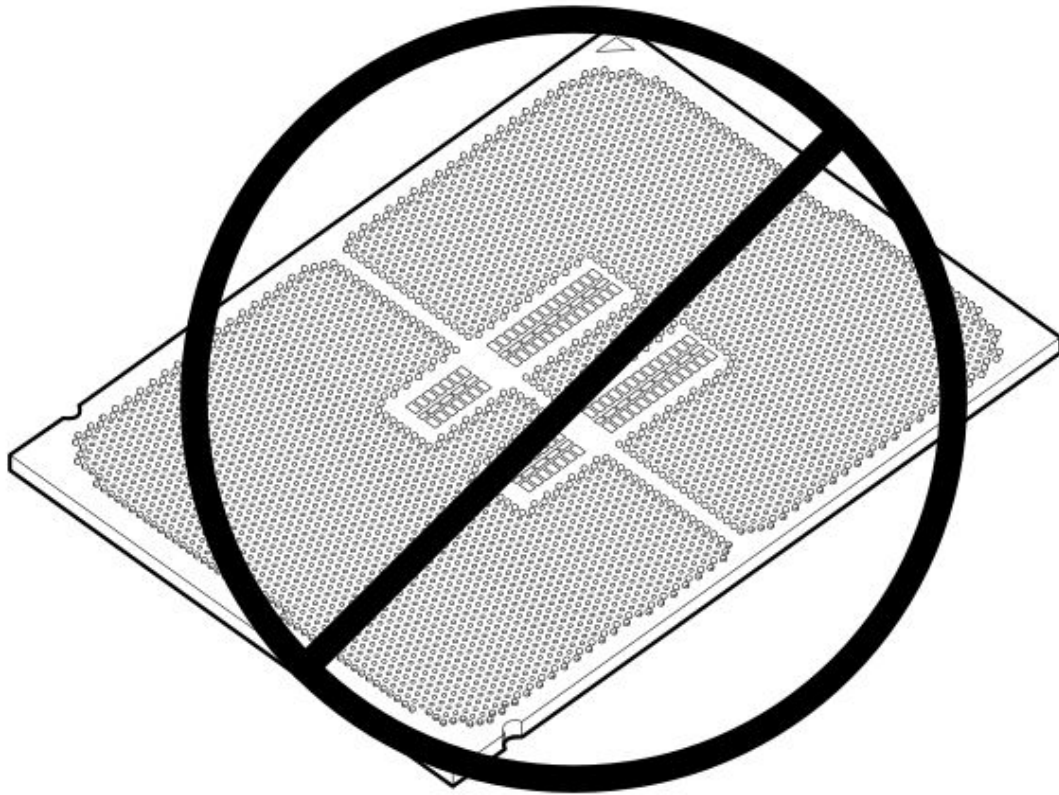
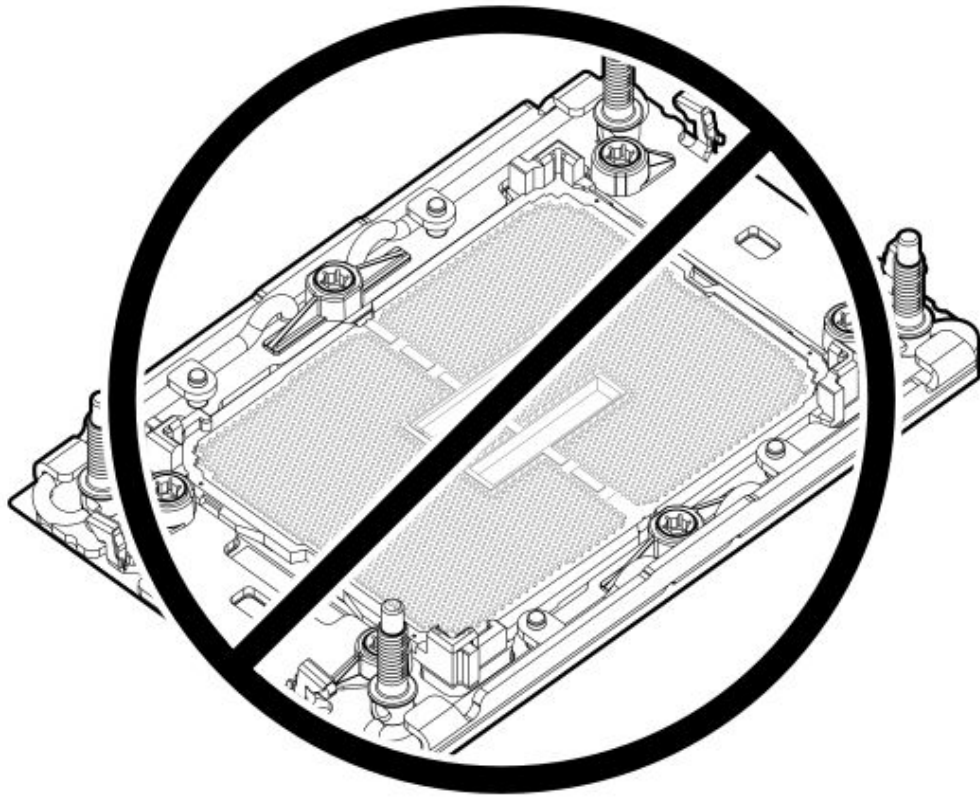

5. Verify that the processor is securely latched to the processor carrier.

The following illustration calls out the keying feature tabs that secure the processor. Different processor carriers will have these tabs in different locations.

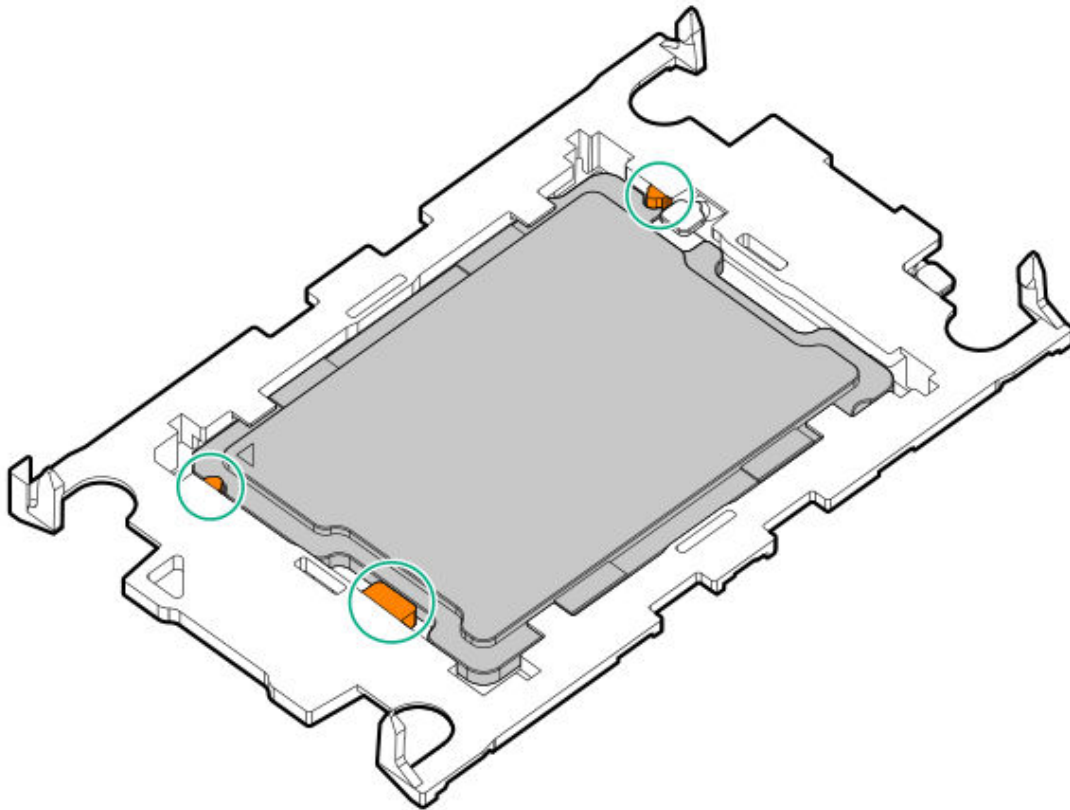

6. Attach the heatsink to the processor carrier:
 - a. Align the pin 1 indicator on the processor carrier with that on the heatsink.

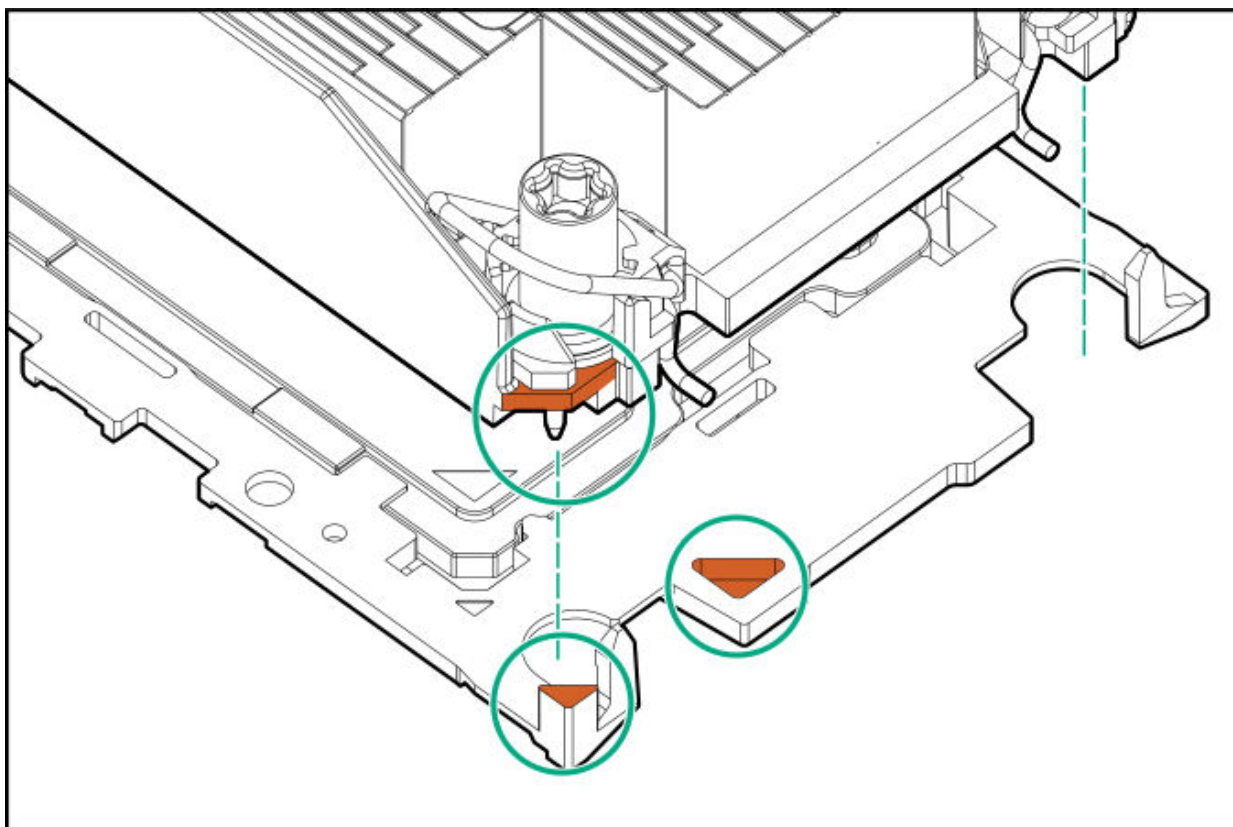

b. Lower the heatsink on the processor carrier until the carrier tabs snap into place.

There will be an audible click to indicate that the heatsink is properly latched on the processor carrier.

- Standard heatsink

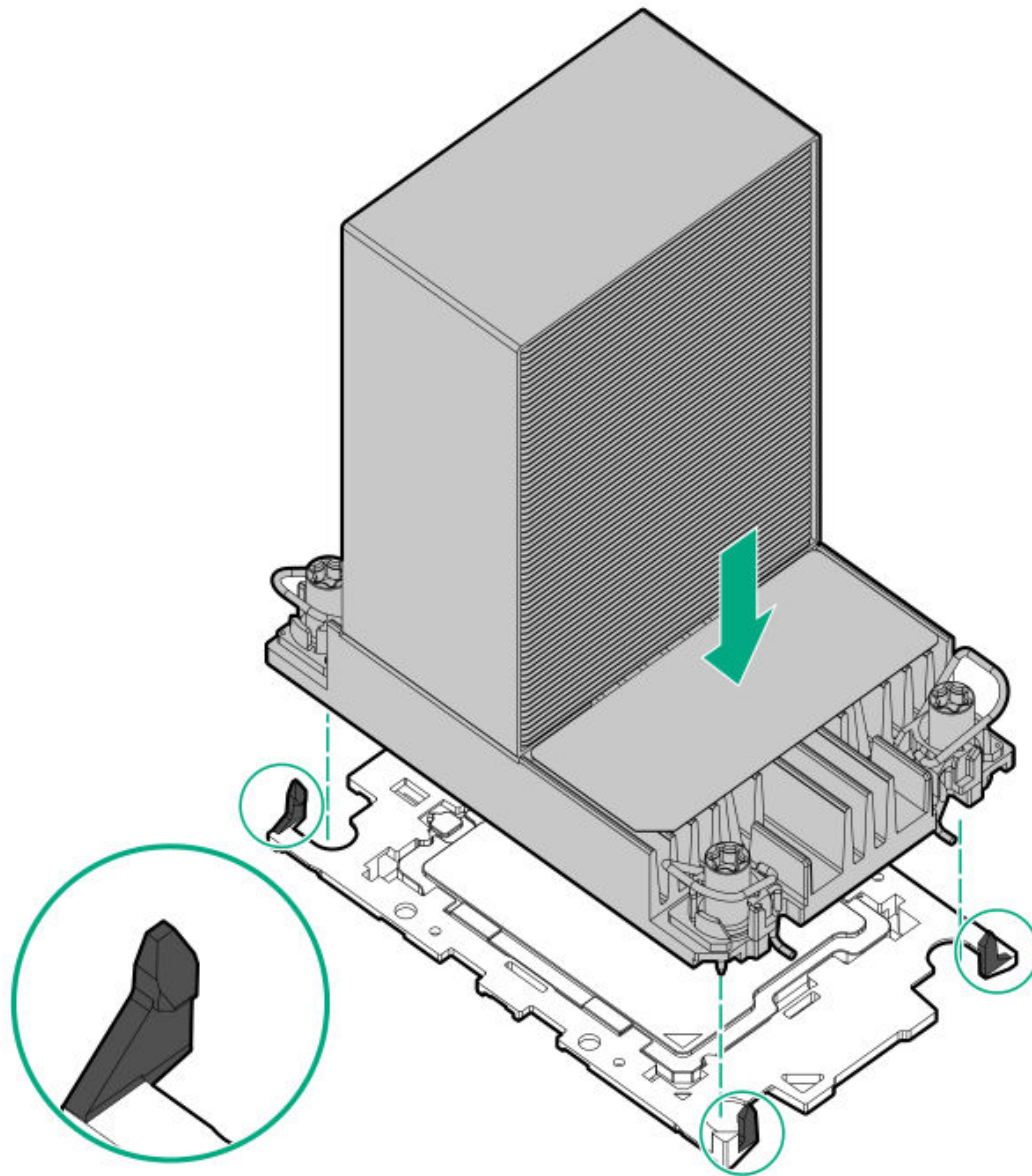

- Performance heatsink

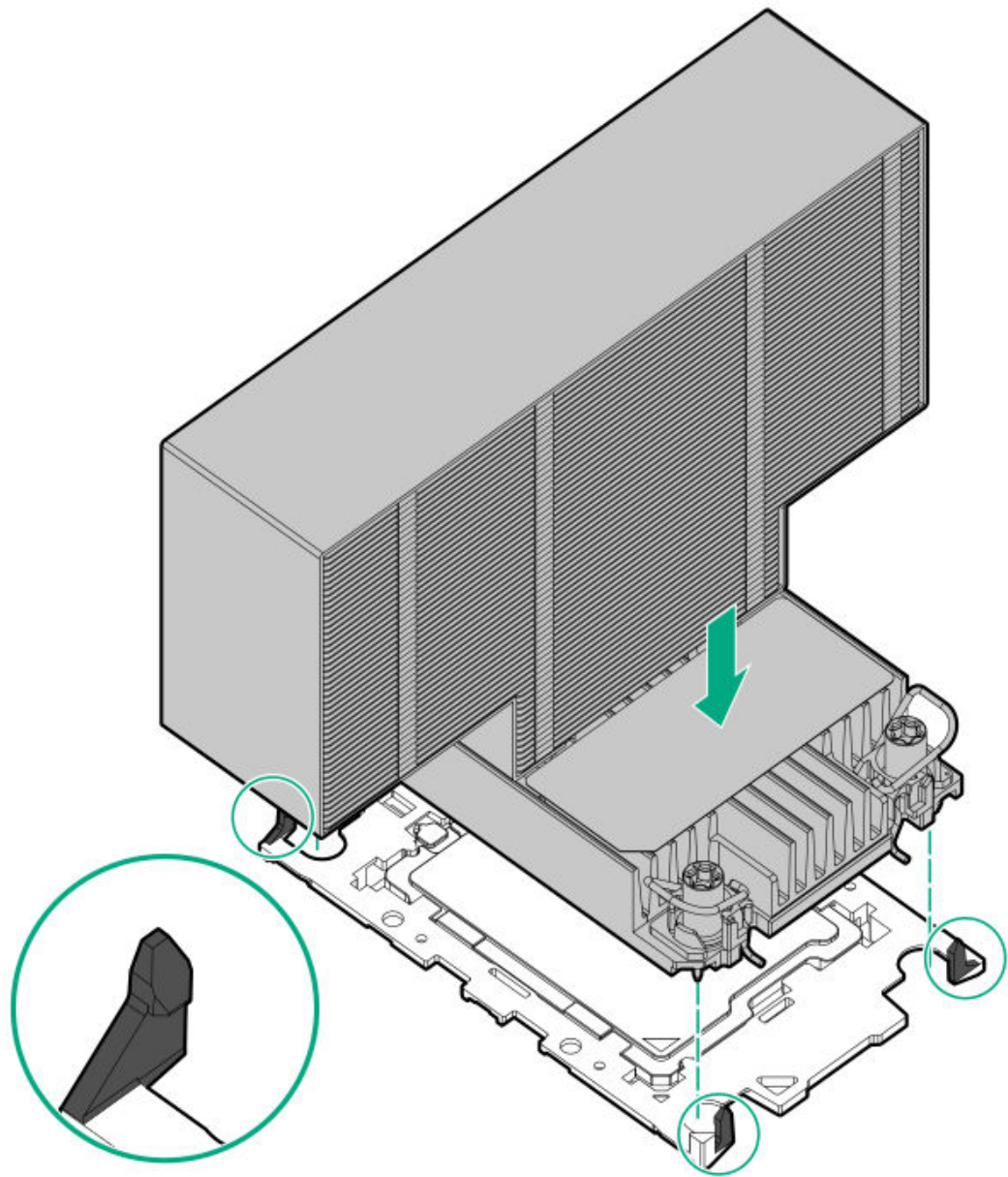

7. Perform the following verification steps:

- a. Verify that the tabs on the processor carrier are securely latched on the heatsink.

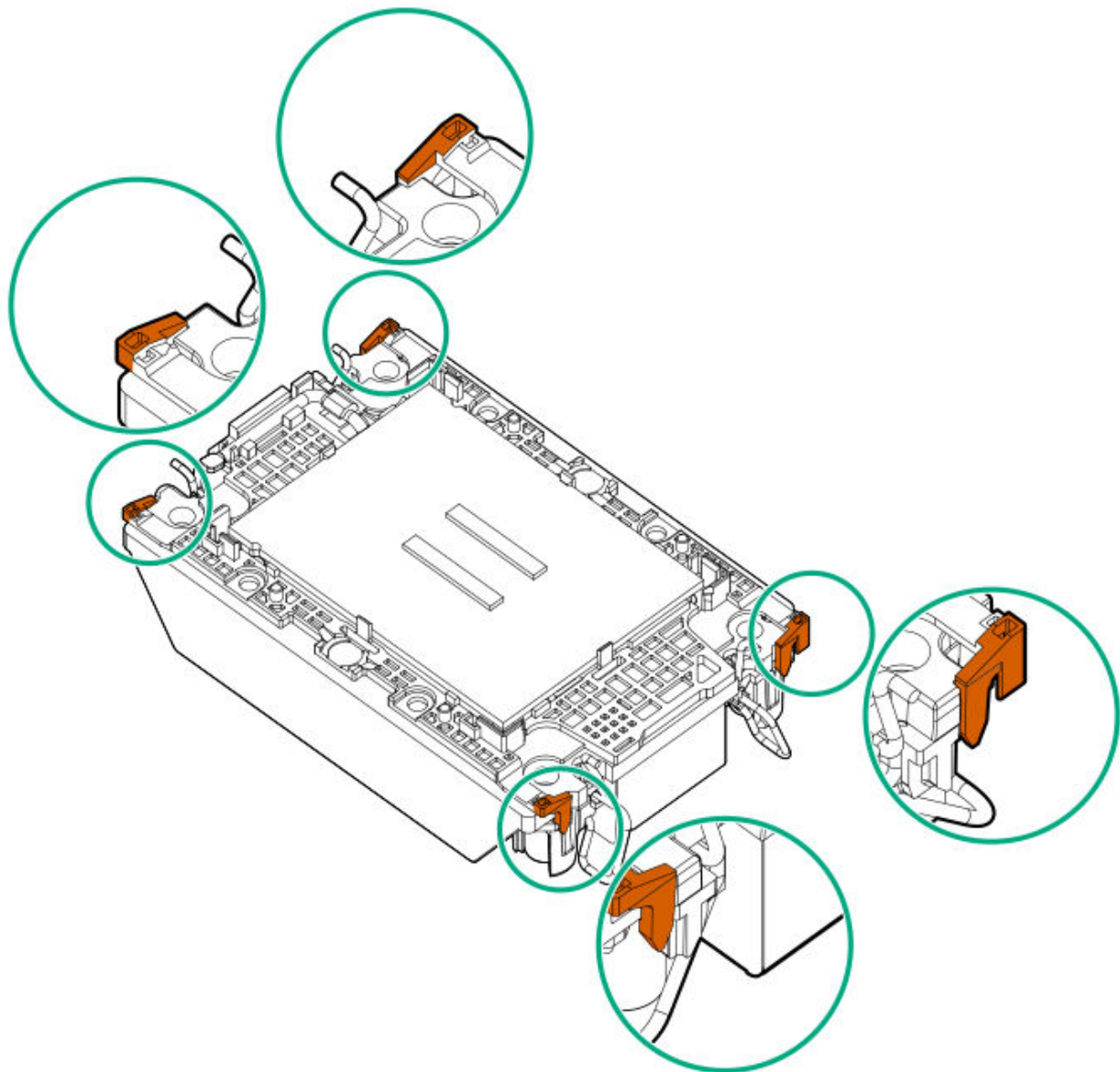

b. Verify that the pin 1 indicators on the processor and processor carrier are aligned.

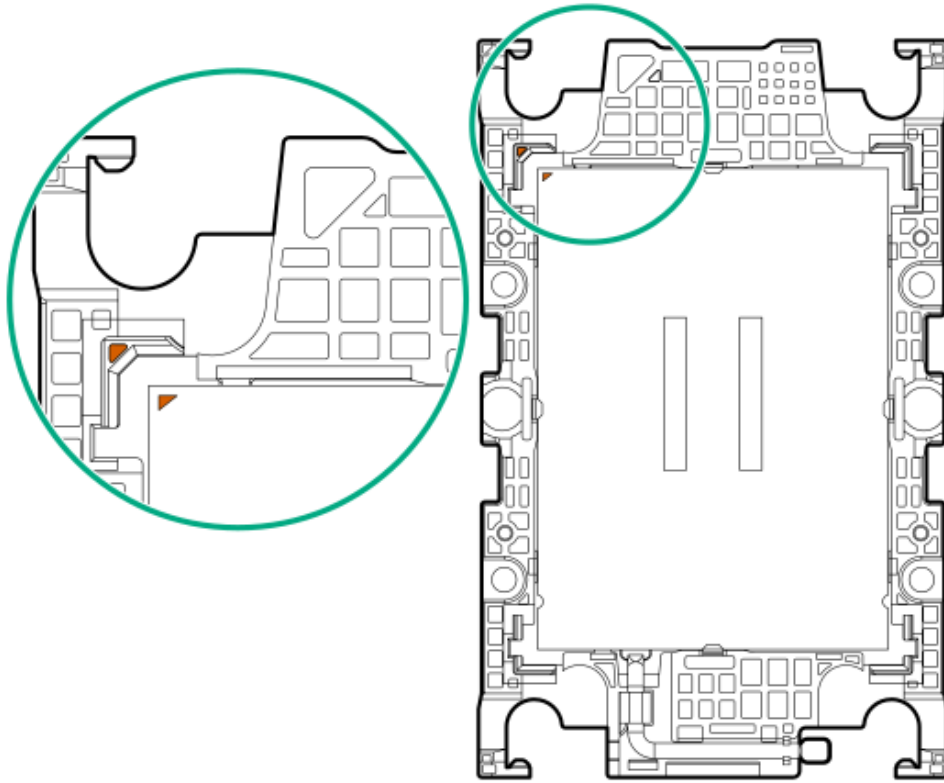

c. Verify that the processor is properly secured by the carrier snaps.

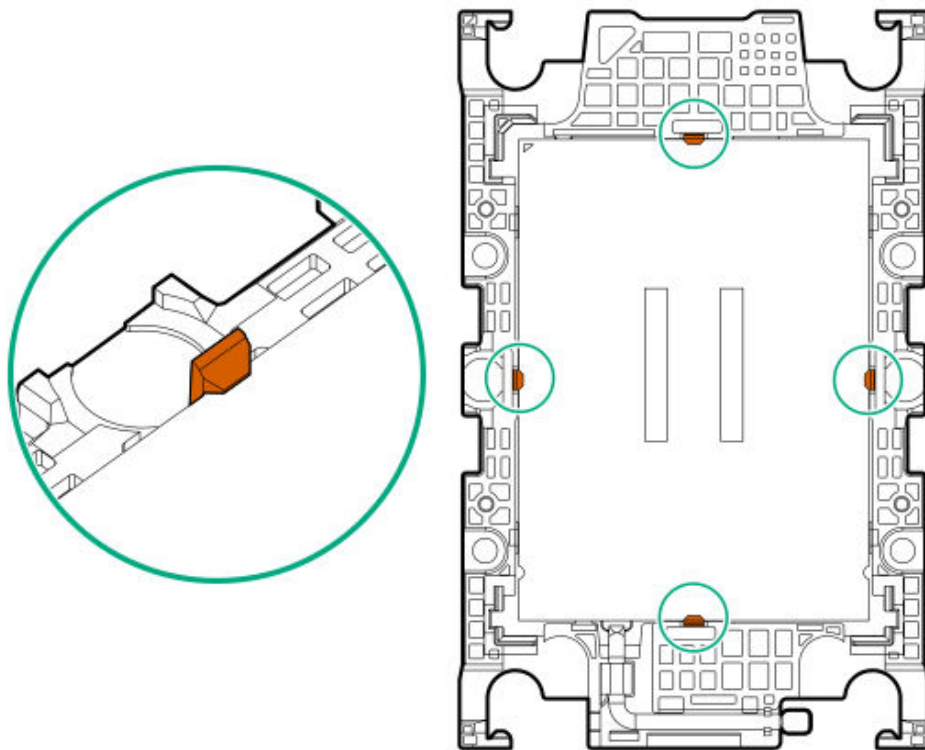

8.



CAUTION

To prevent thermal failure or component damage, do not move the heatsink once the bottom of its base plate touches the top of the processor. Excessive heatsink movement can cause the thermal grease to smear and become uneven. Voids in the compound can adversely impact the transfer of heat away from the processor.

Install the processor-heatsink module:

- a. When using a torque wrench to tighten the heatsink screws, set 0.9 N-m (8 in-lb) of torque.
- b. Note the **Front of server** text on the heatsink label to correctly orient the processor-heatsink module over the bolster plate.
- c. Carefully lower the processor-heatsink module straight down onto the bolster plate guide posts.

The posts are keyed so that the module can only be installed one way. Make sure that the module is properly seated on the bolster plate before securing the screws.

- Standard heatsink

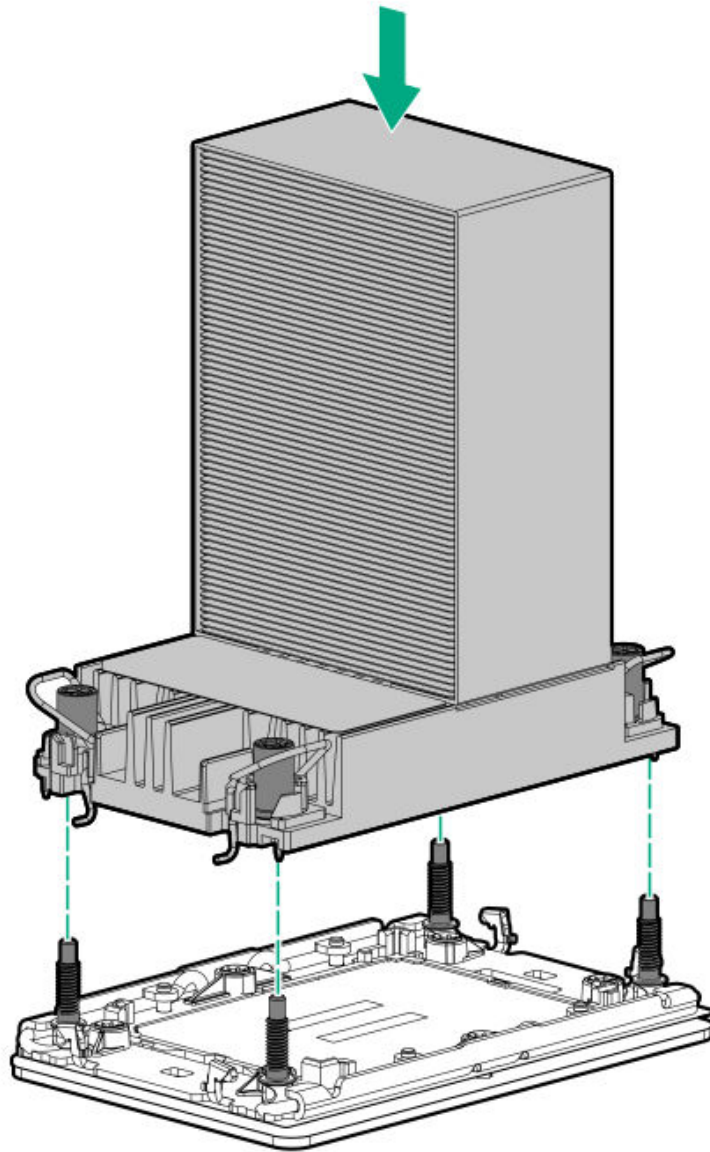

- Performance heatsink

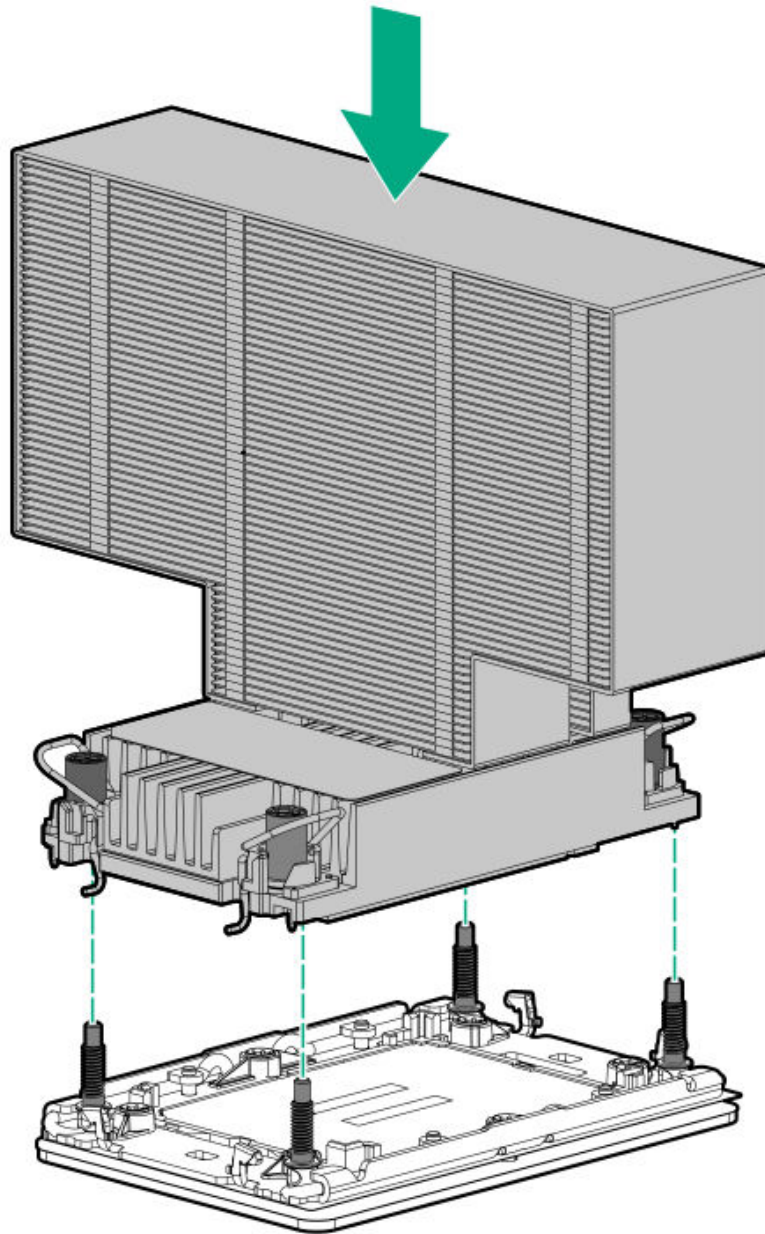

d. Set the anti-tilt wires to the locked position.

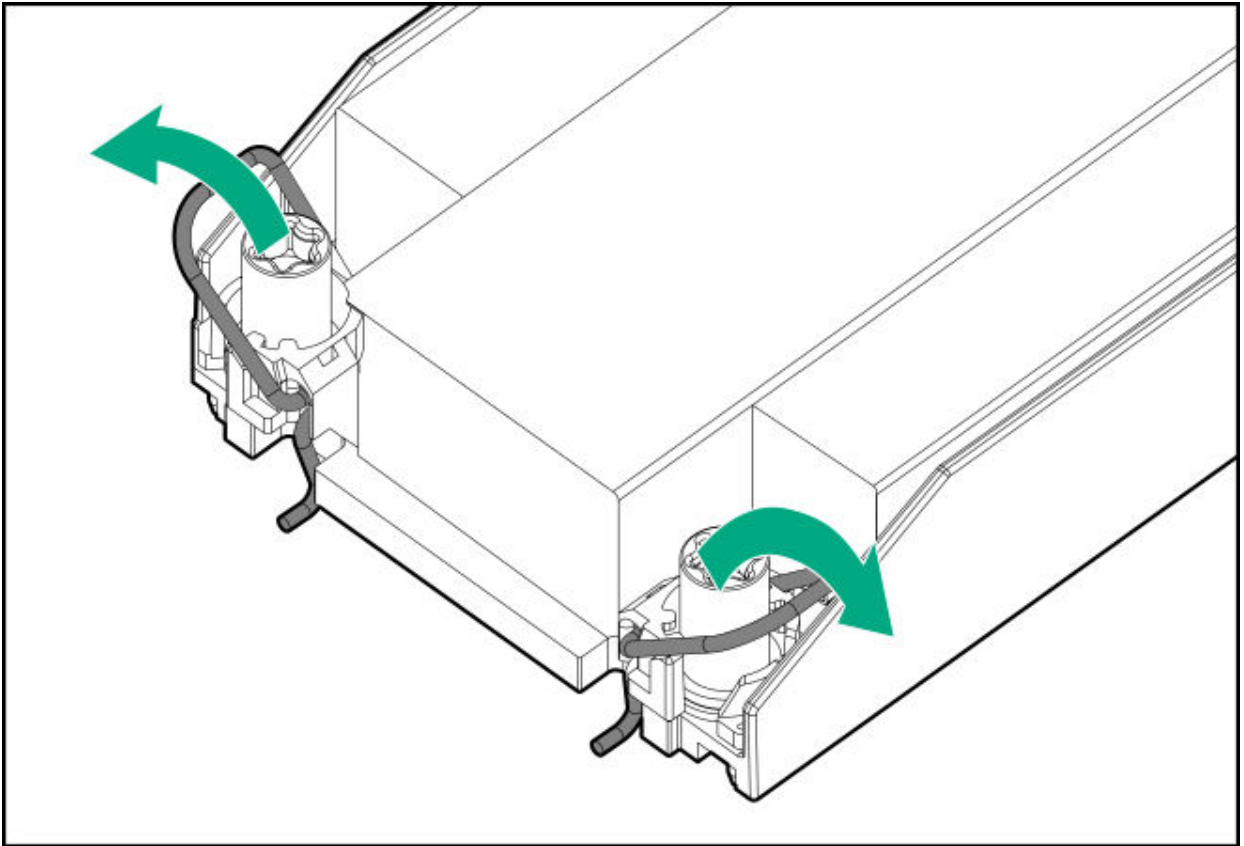

e. Tighten one pair of diagonally opposite heatsink screws, and then tighten the other pair of heatsink screws.

- Standard heatsink

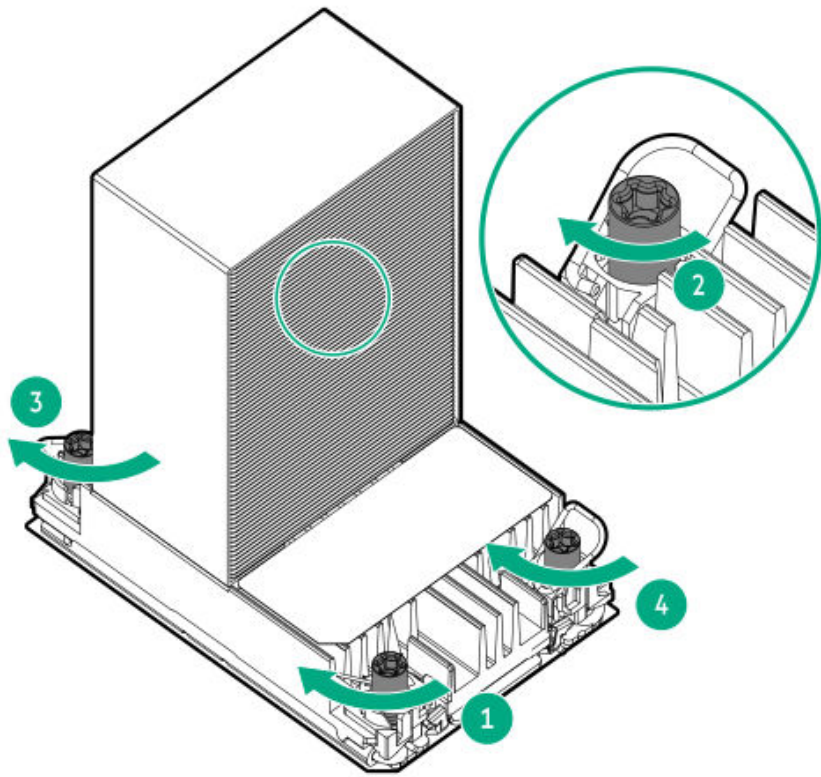

- Performance heatsink

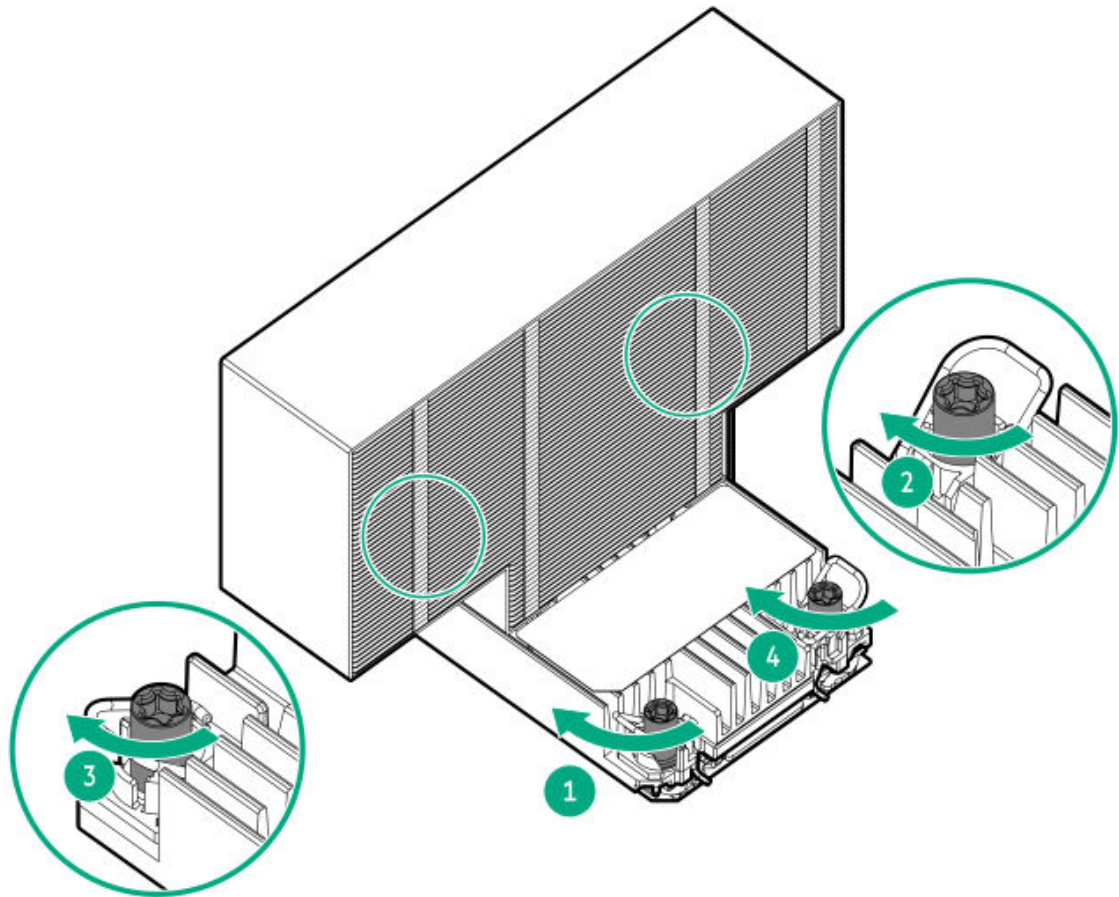

9. Install the riser cages.
0. Install the fan cage.
- .1. Install the access panel.
- .2. Lock the front bezel.
- .3. Do one of the following:
 - Orient the server back in tower mode.
 - Install the server into the rack.
- .4. Connect all peripheral cables to the server.
- .5. Connect each power cord to the server.
- .6. Connect each power cord to the power source.
- .7. Power up the server.

Results

The replacement procedure is complete.

System board replacement

Subtopics

[Removing the system board](#)

[Installing the system board](#)

[Re-entering the server serial number and product ID](#)

Removing the system board

Prerequisites



CAUTION

Be sure to have the BitLocker recovery key/password prior to replacing the system board. If you do not have the key/password, you will need to reinstall the OS.

- [Perform a backup of critical server data.](#)
- Before you perform this procedure, make sure that you have the following items available:
 - T-15 Torx screwdriver
 - T-30 Torx screwdriver

About this task



WARNING

To reduce the risk of personal injury from hot surfaces, allow the drives and the internal system components to cool before touching them.



CAUTION

A discharge of static electricity from a finger or other conductor might damage system boards or other static-sensitive devices. To prevent damage, observe [antistatic precautions.](#)

Procedure

1. Power down the server.
2. Remove all power:
 - a. Disconnect each power cord from the power source.
 - b. Disconnect each power cord from the server.
3. Disconnect all peripheral cables from the server.
4. If the server is in tower mode, place the server on a flat, level surface with the access panel facing up.
5. If the server is in rack mode, do one of the following, remove the server from the rack.
6. Unlock the front bezel.
7. Remove the access panel.
8. Remove the fan cage.
9. Allow all internal system components to cool before continuing.
0. Remove the fan cage.
- .1. Do the following:
 - Remove the primary riser cage.
 - Remove the secondary riser cage.
- .2. Disconnect all cables from the expansion cards, riser boards, and the system board.
- .3. Remove all DIMMs.
- .4. If installed, remove the following components:
 - Type-o storage controller
 - OCP NIC 3.0 adapter
- .5. Remove the cable clamps.
- .6. Loosen one pair of diagonally opposite screws, and then loosen the other pair of screws.



CAUTION

Heatsink screws must be tightened and loosened in alternating sequence. Do not overtighten the screws as this might damage the system board or the processor socket.

- Standard heatsink

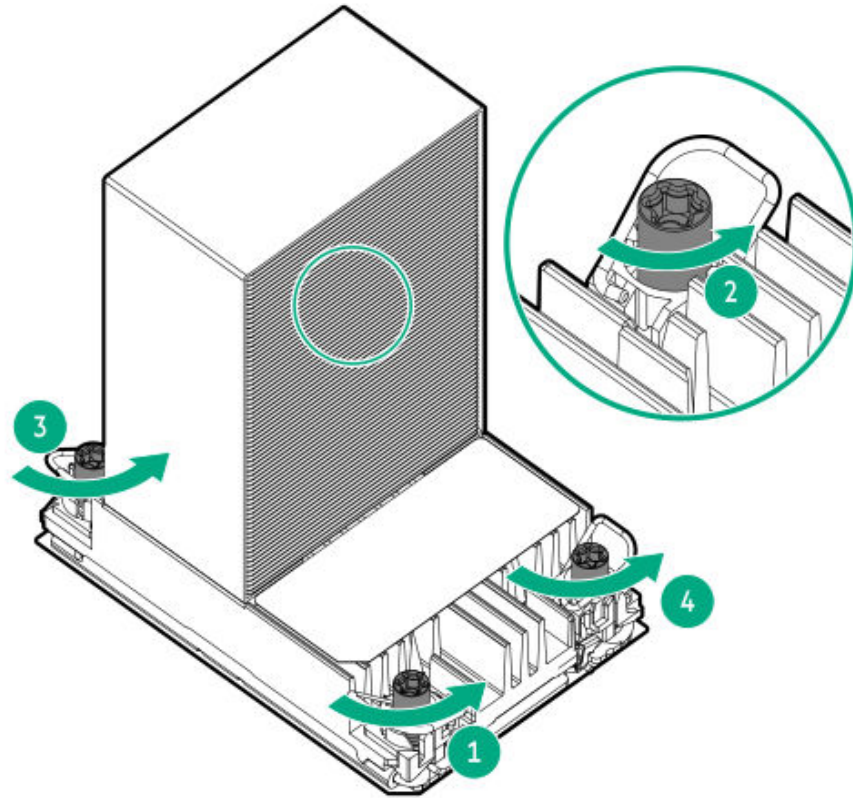

- Performance heatsink

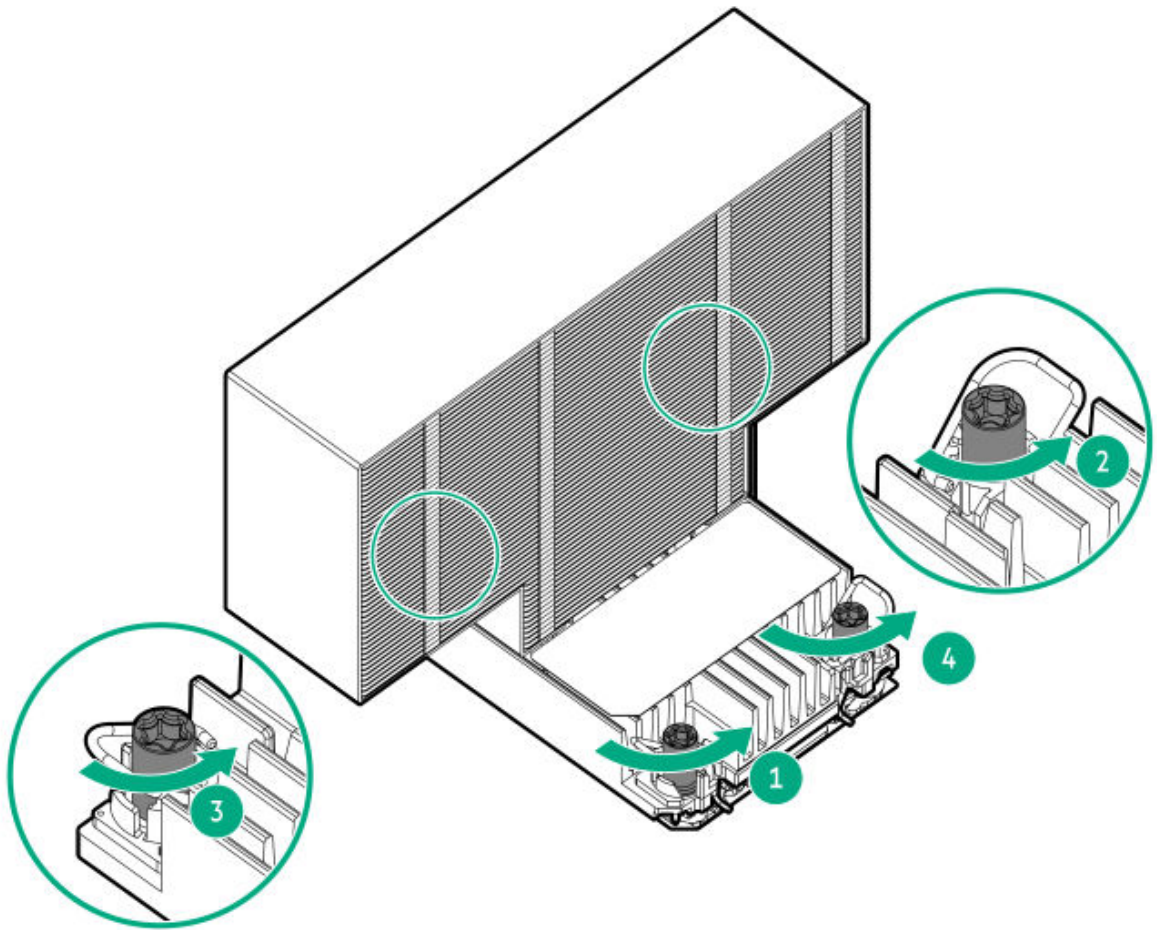

.7. Set the anti-tilt wires to the unlocked position.

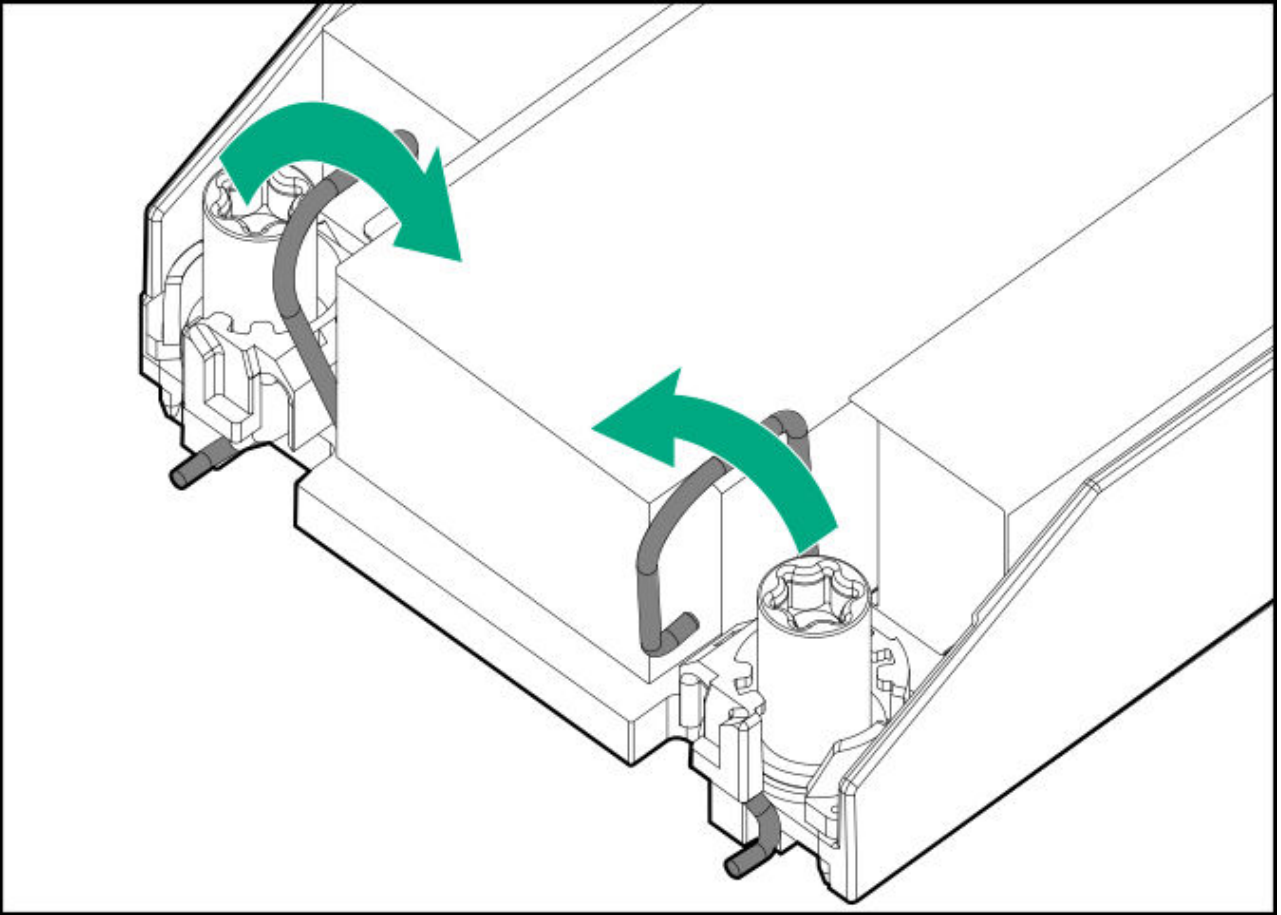

.8. Lift the processor-heatsink module straight up from the system board.



CAUTION

To prevent mechanical damage or depositing oil on your hands or other contaminants to the heatsink contact surface, hold the heatsink only by the edge of its base plate. Do not touch the heatsink fins.

- Standard heatsink

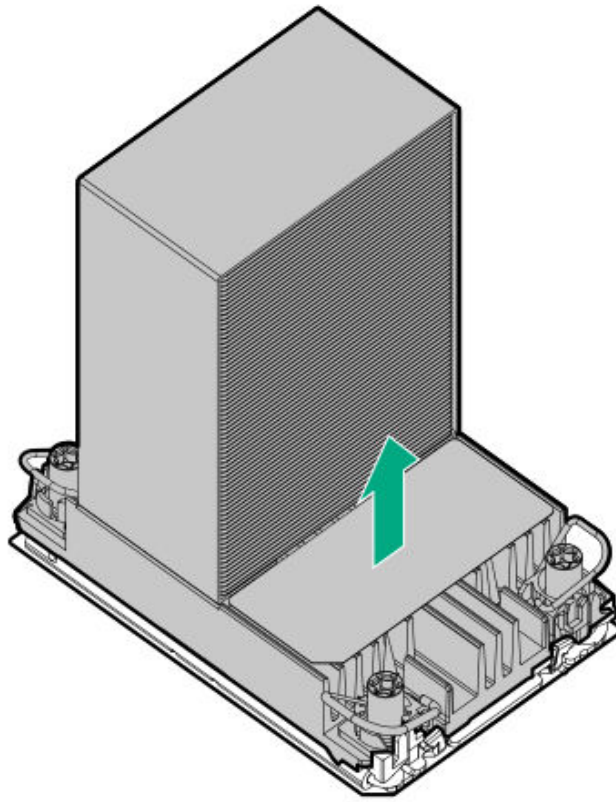

- Performance heatsink

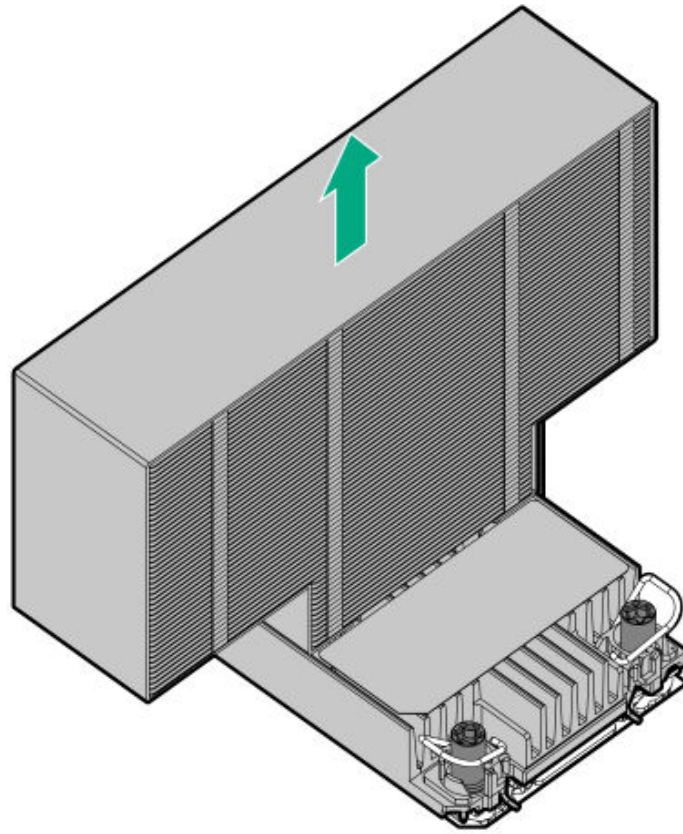

9. Place the processor-heat sink module on a flat work surface with its contact side facing up.
10. Remove the fan cage bracket:
 - a. Retract and hold the spring plunger.
 - b. Slide the bracket towards the front of the chassis to release it.

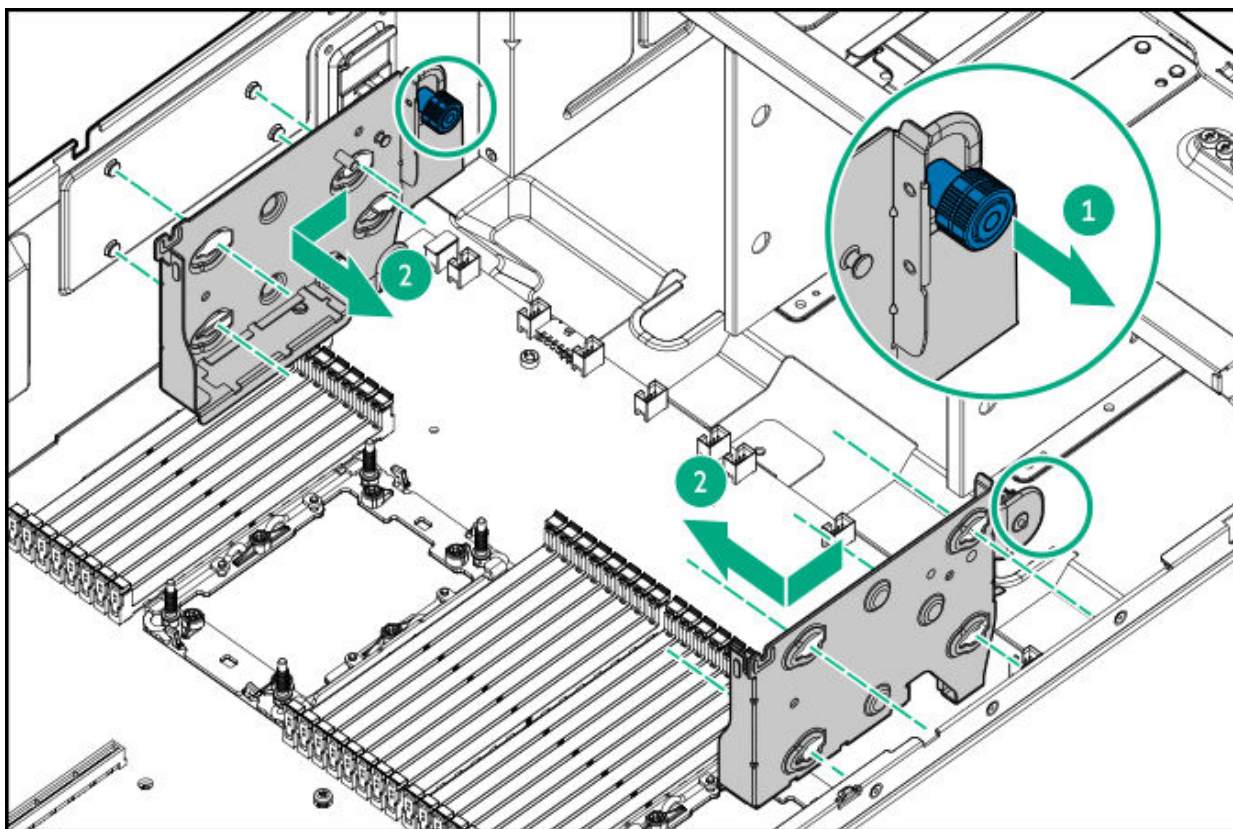

!1. Remove the system board latches:

- a. Remove the latch screw.
- b. Press and hold the release tab, and then remove the latch from the system board.

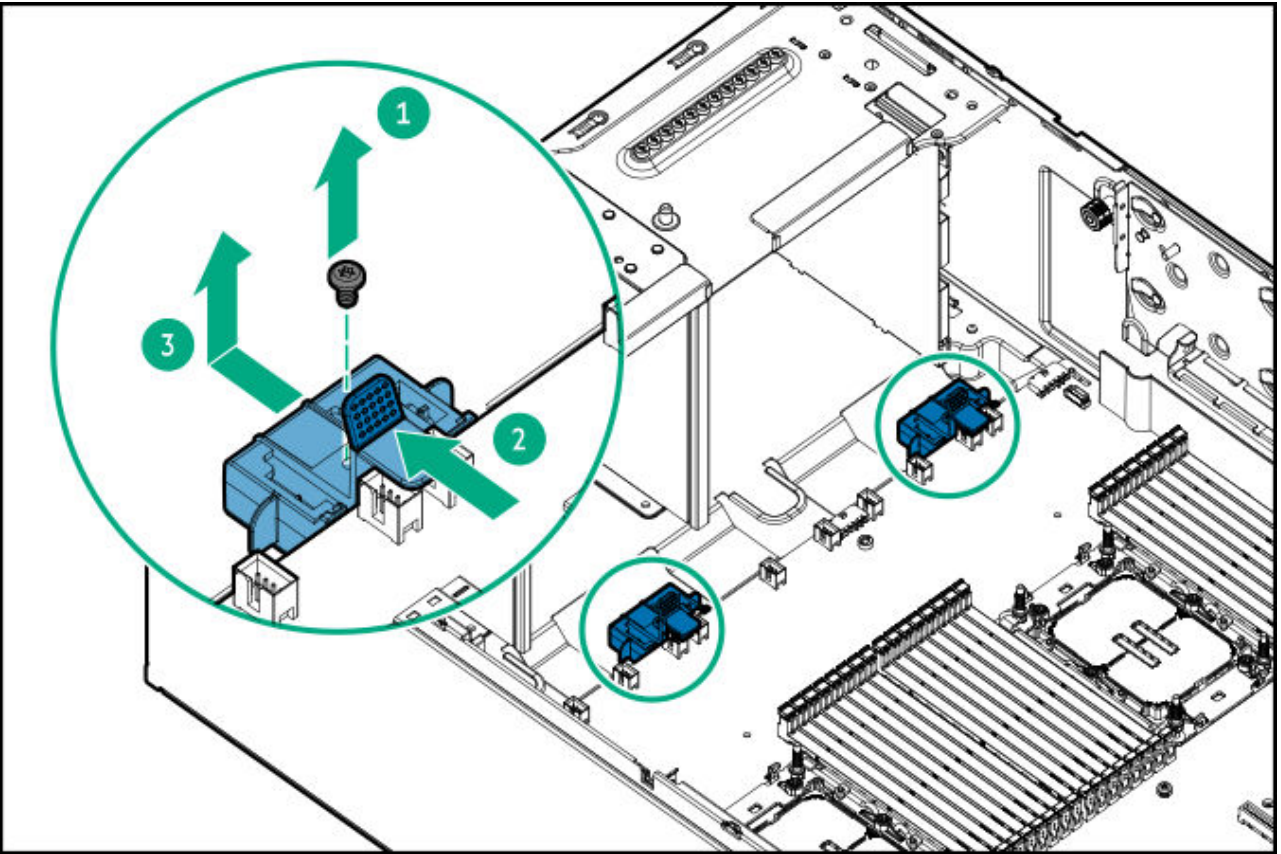

!2. Remove the system board:

a. Loosen the system board thumbscrew.

b. Use the system board handle and thumbscrew to remove the system board from the rear panel.

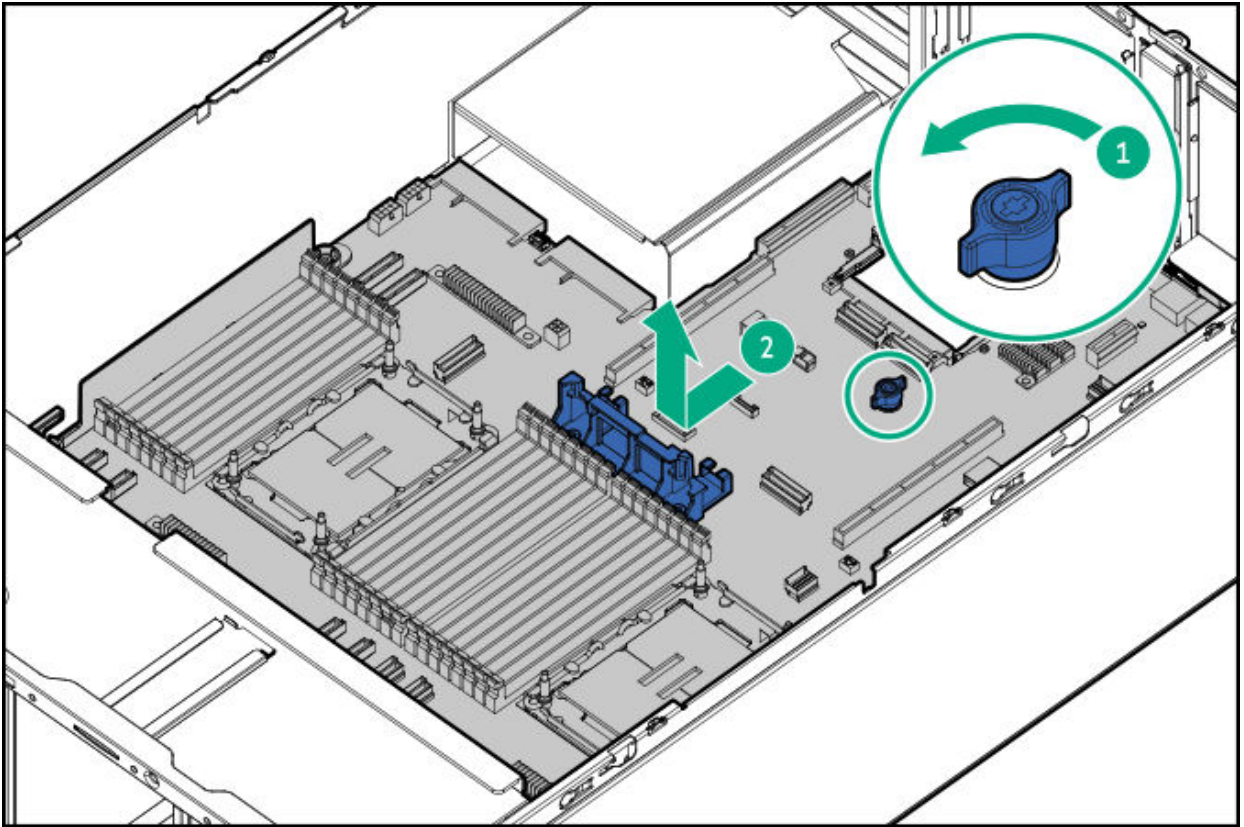

!3. Remove the following components from the removed system board:

- System board handle

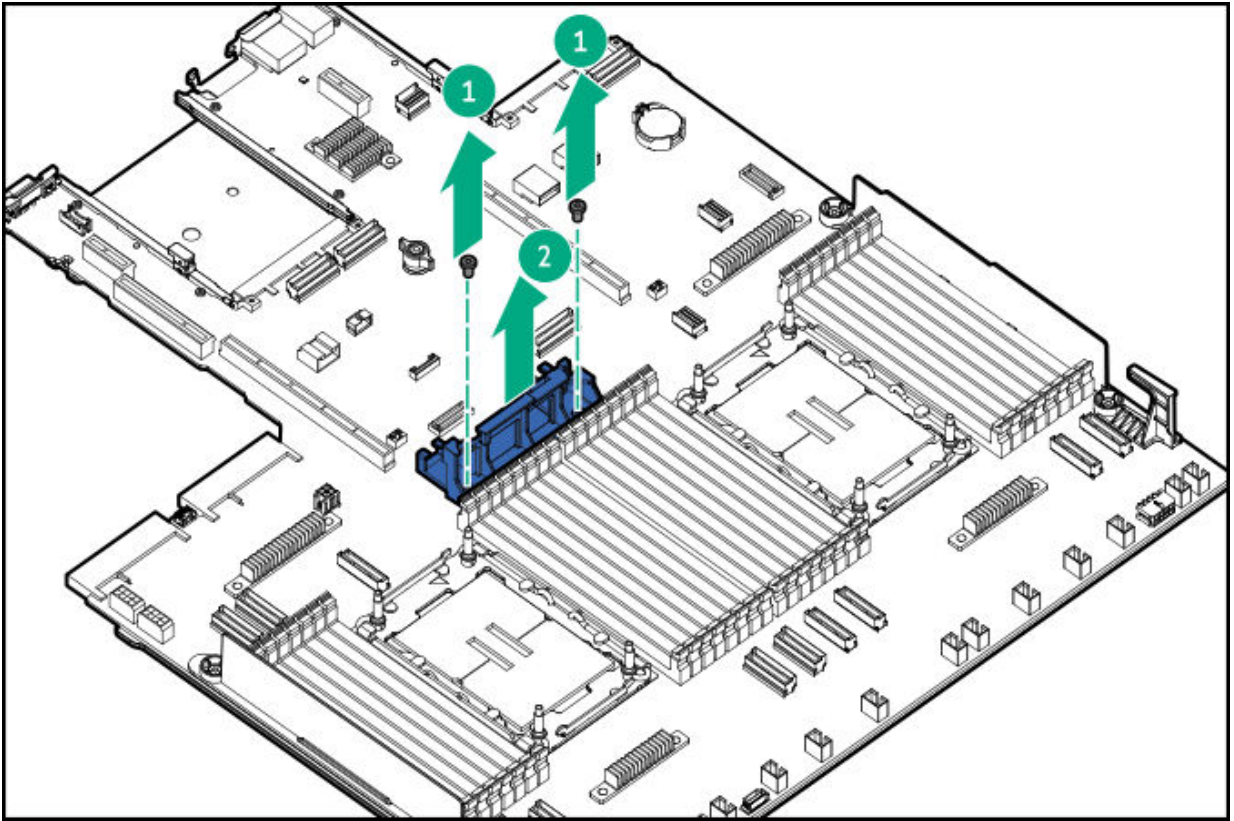

- Left DIMM guard

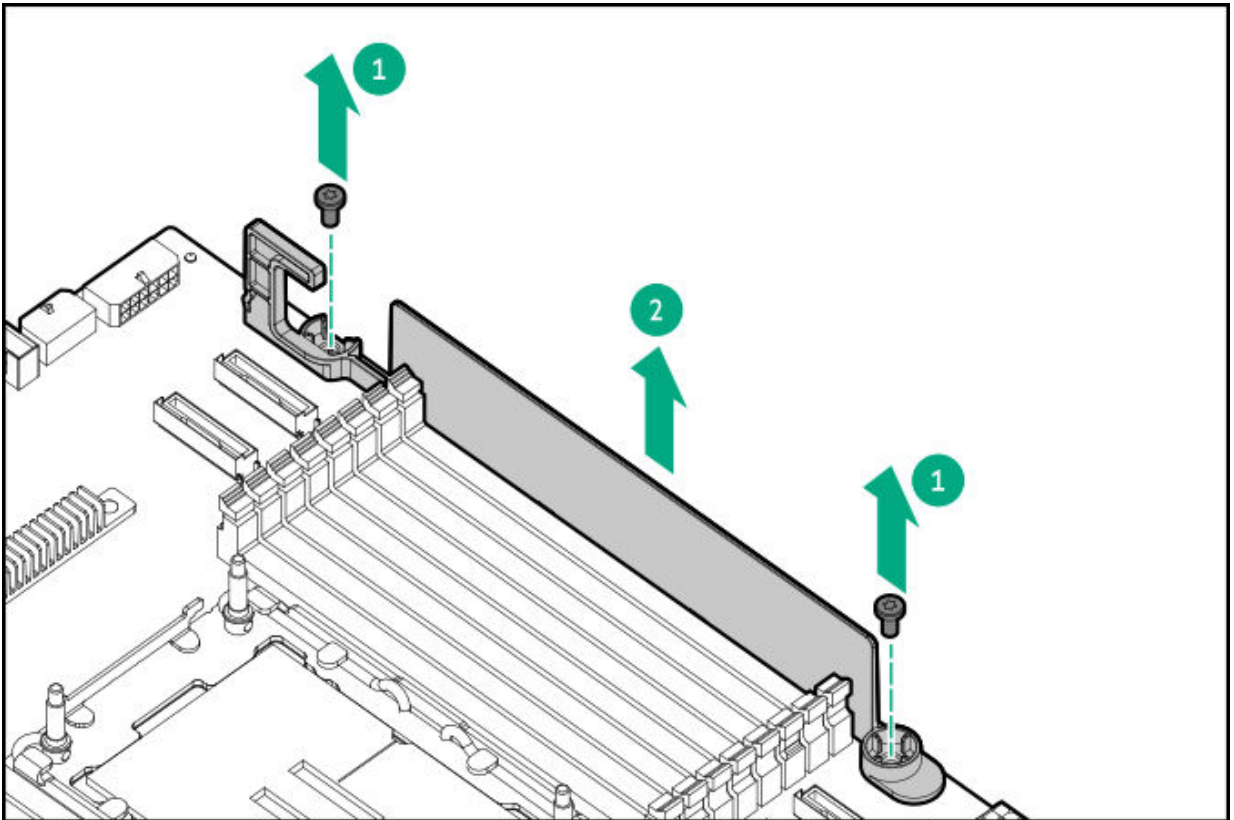

- Right DIMM guard

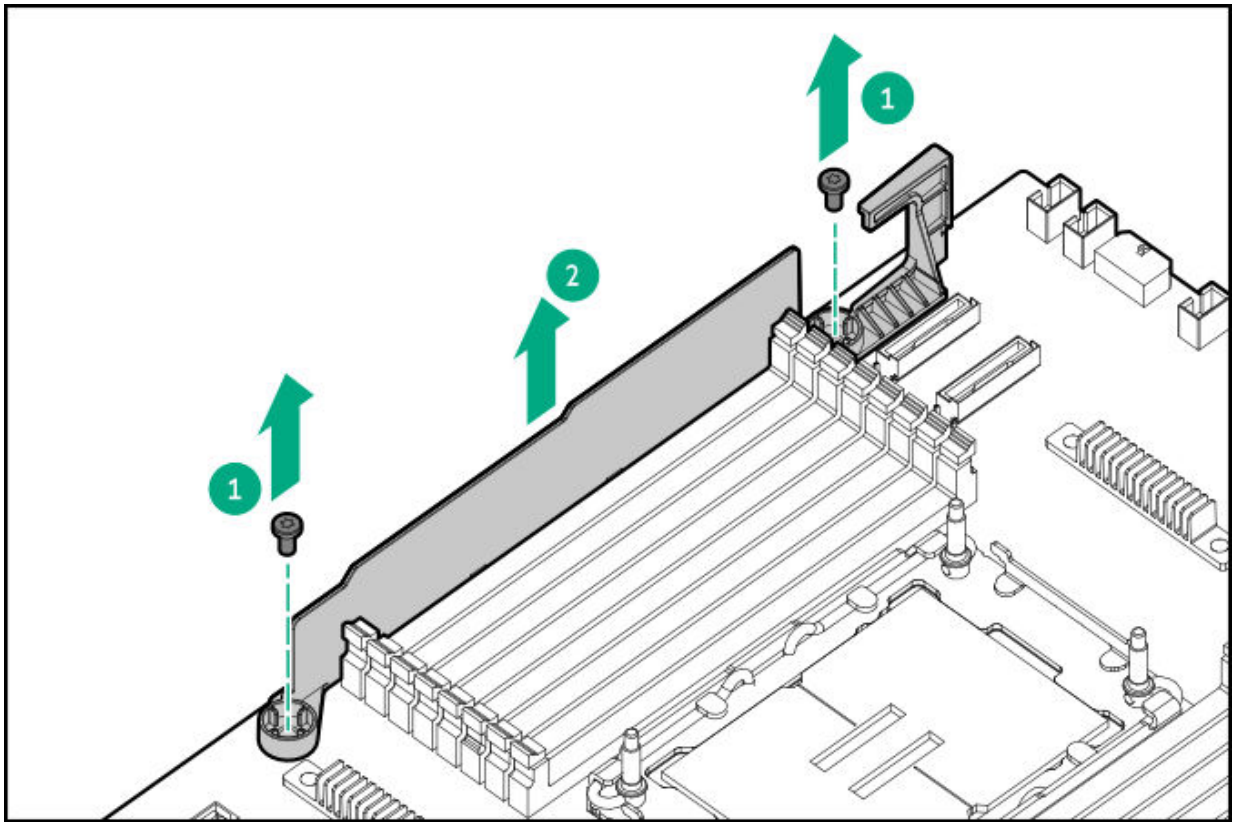

Installing the system board

Prerequisites



CAUTION

Be sure to have the BitLocker recovery key/password prior to replacing the system board. If you do not have the key/password, you will need to reinstall the OS.



CAUTION

Do not use One-button secure erase (OBSE). OBSE should only be used to decommission or repurpose a system. **This option erases all data. Be sure to disconnect any drives, SANs, NAS, or other shared/external storage devices that you do not want erased.**

Before you perform this procedure, make sure that you have the following items available:

- Torque screwdriver with T-30 Torx bit
- T-15 Torx screwdriver
- Thermal grease (spare part number: 777298-001)
- Hex screwdriver—This tool is required only if the serial port cable is to be installed.

About this task



CAUTION

A discharge of static electricity from a finger or other conductor might damage system boards or other static-sensitive devices. To prevent damage, observe antistatic precautions.

Procedure

1. Install the following components on the replacement system board:

- Left DIMM guard

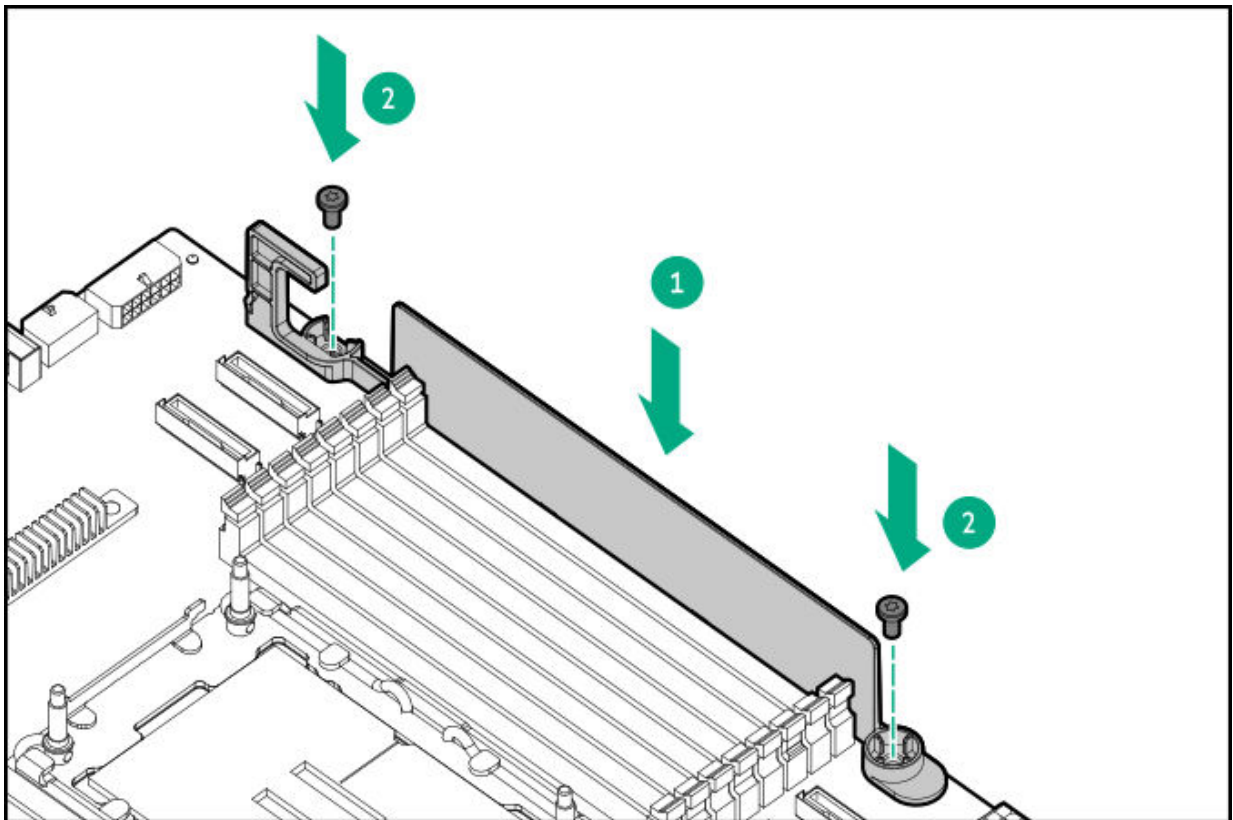

- Right DIMM guard

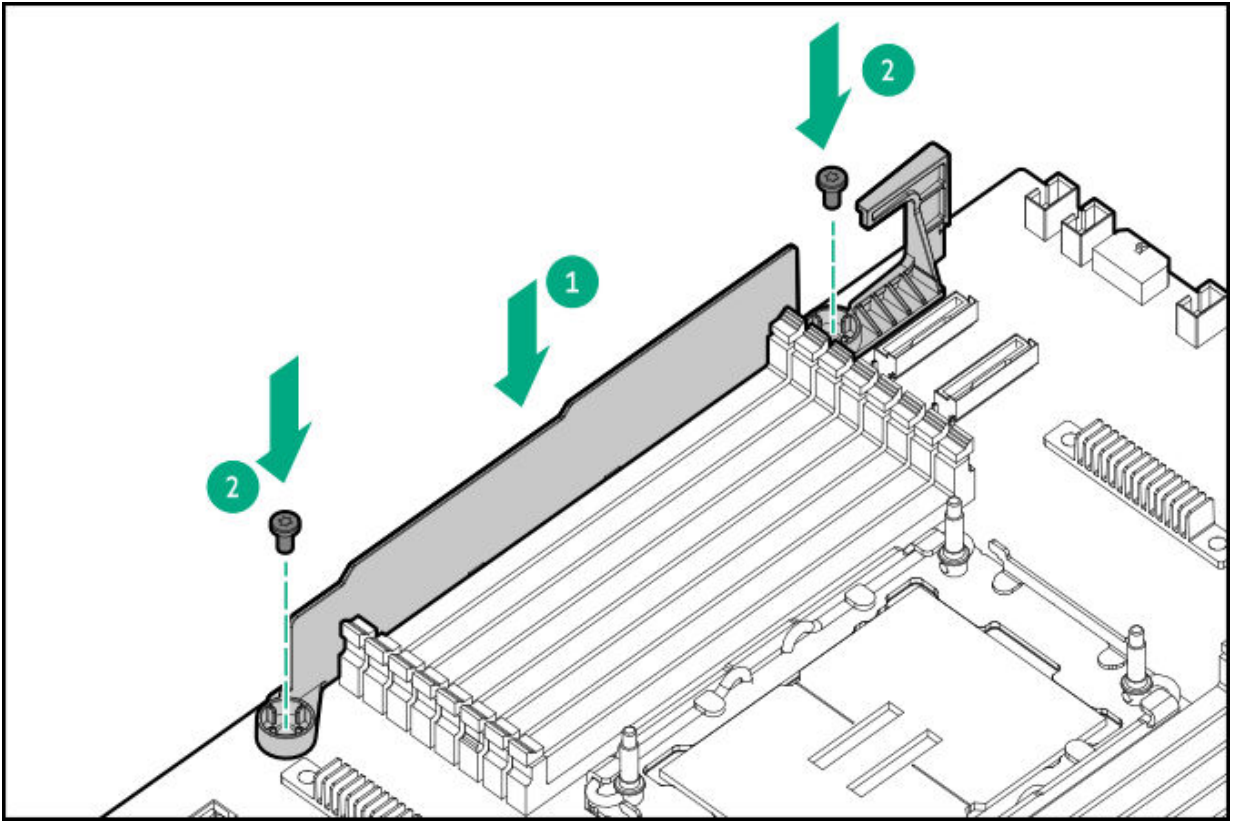

- System board handle

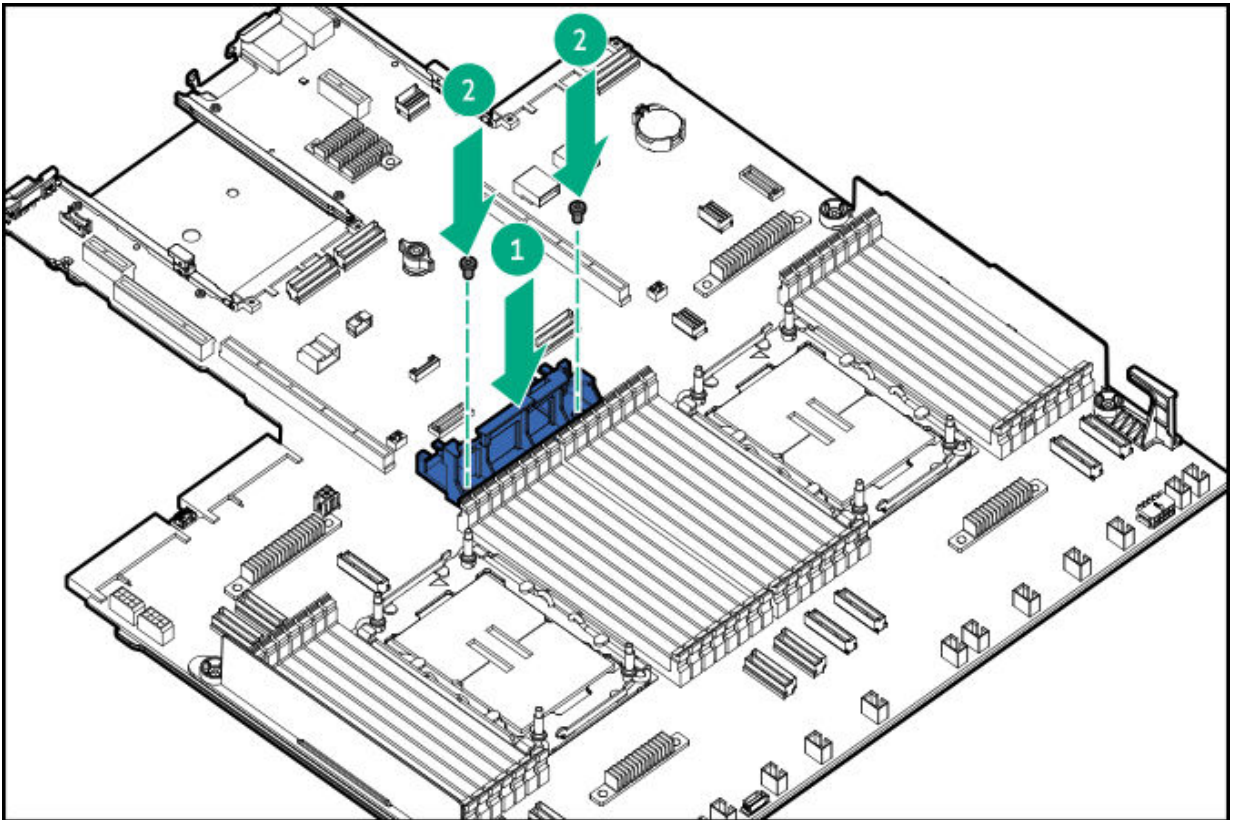

2. Position the new system board over the alignment tabs on the chassis.

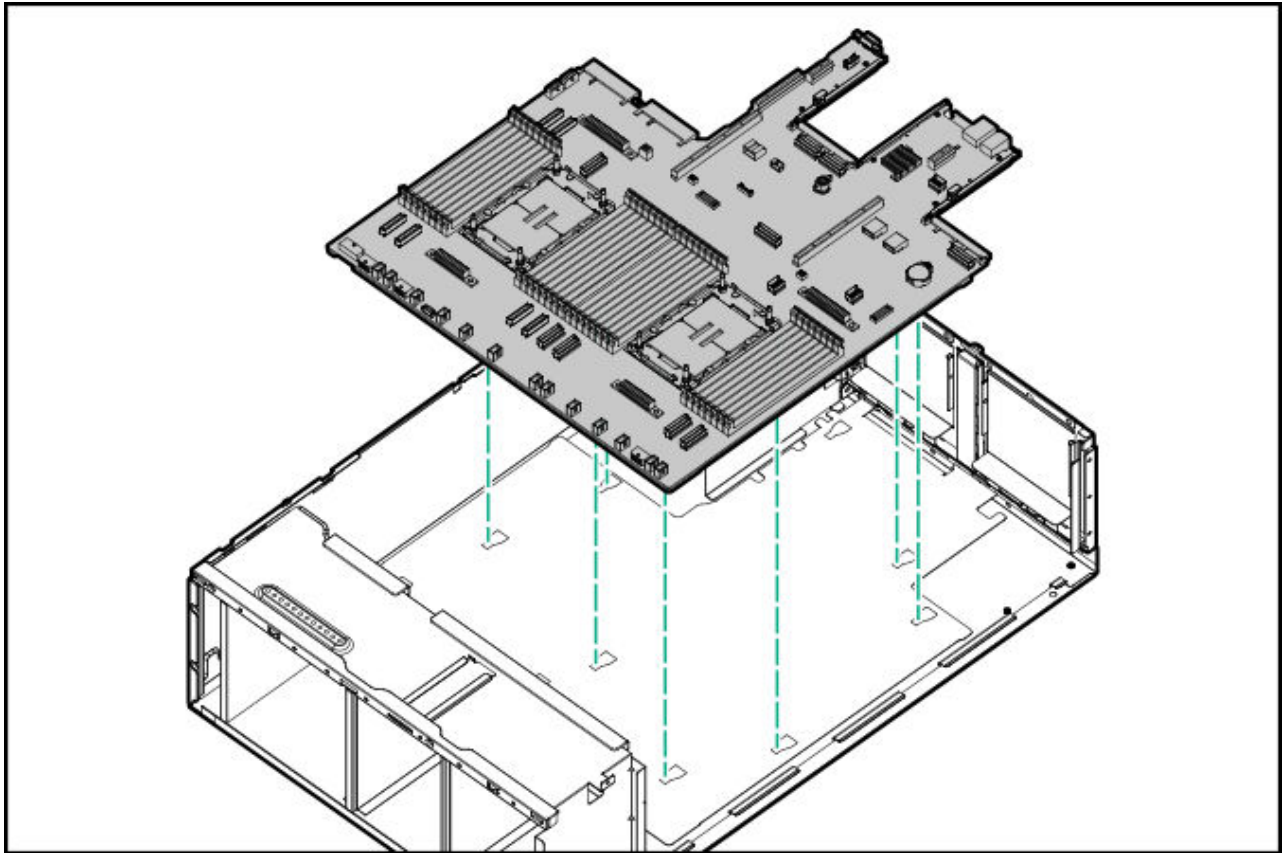

3. Install the new system board:
 - a. Insert the system board on the rear side of the chassis.
 - b. Tighten the captive screw.

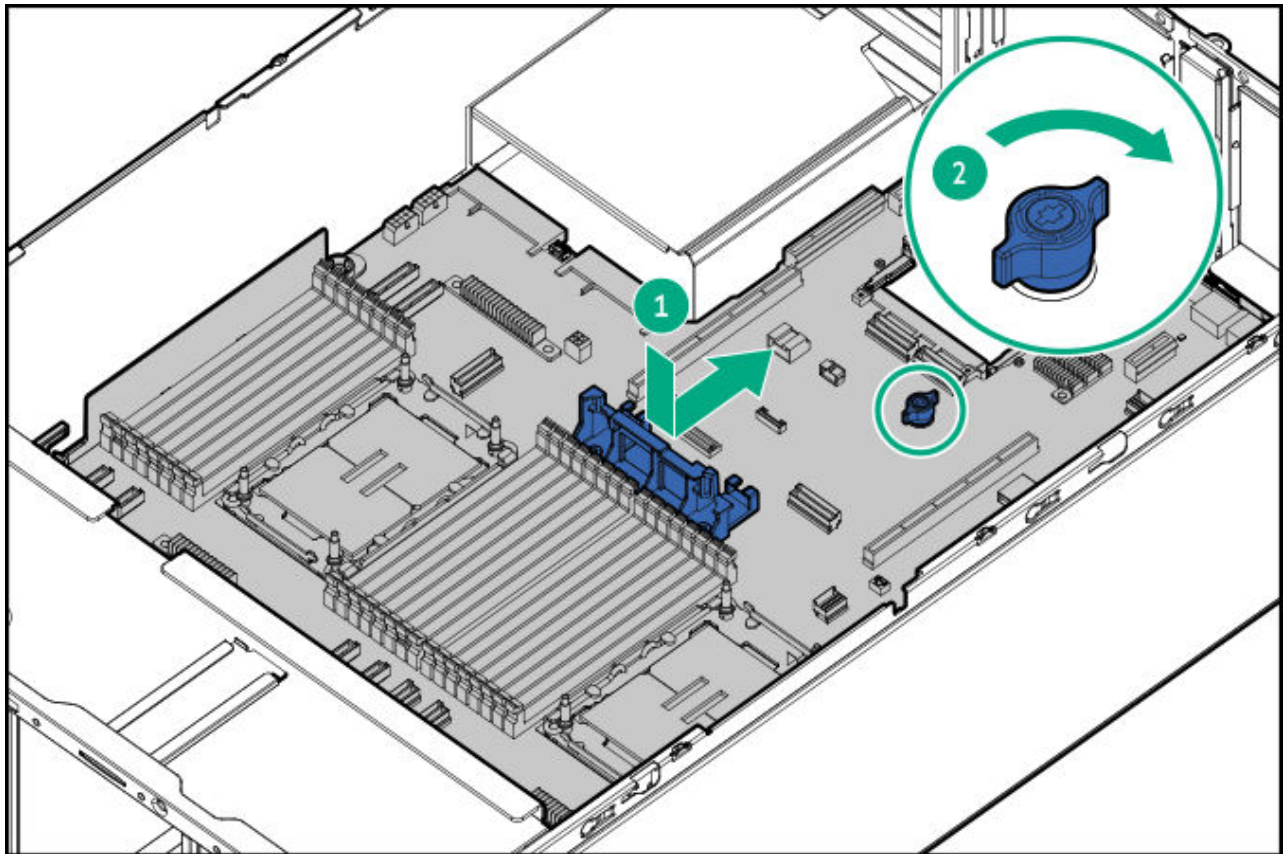

4. Do the following:

- Install the system board latches.
- Install the fan cage brackets.

5. Remove the dust cover from the processor socket:

 **CAUTION**

Do not press down on the dust cover. Pressing down on the dust cover might damage the processor socket.

- a. Press and hold the grip tabs on the dust cover.
- b. Lift the dust cover away from the bolster plate.

Retain the cover for future use.

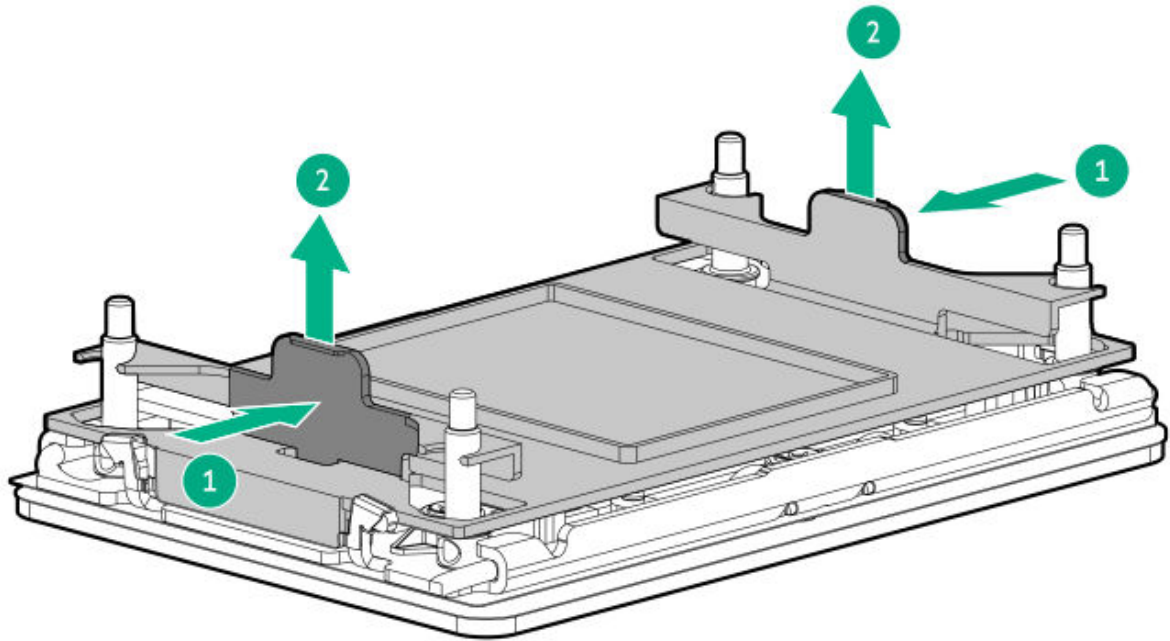

6.



CAUTION

To prevent thermal failure or component damage, do not move the heatsink once the bottom of its base plate touches the top of the processor. Excessive heatsink movement can cause the thermal grease to smear and become uneven. Voids in the compound can adversely impact the transfer of heat away from the processor.

Install the processor-heatsink module:

- a. When using a torque wrench to tighten the heatsink screws, set 0.9 N-m (8 in-lb) of torque.
- b. Note the **Front of server** text on the heatsink label to correctly orient the processor-heatsink module over the bolster plate.
- c. Carefully lower the processor-heatsink module straight down onto the bolster plate guide posts.

The posts are keyed so that the module can only be installed one way. Make sure that the module is properly seated on the bolster plate before securing the screws.

- Standard heatsink

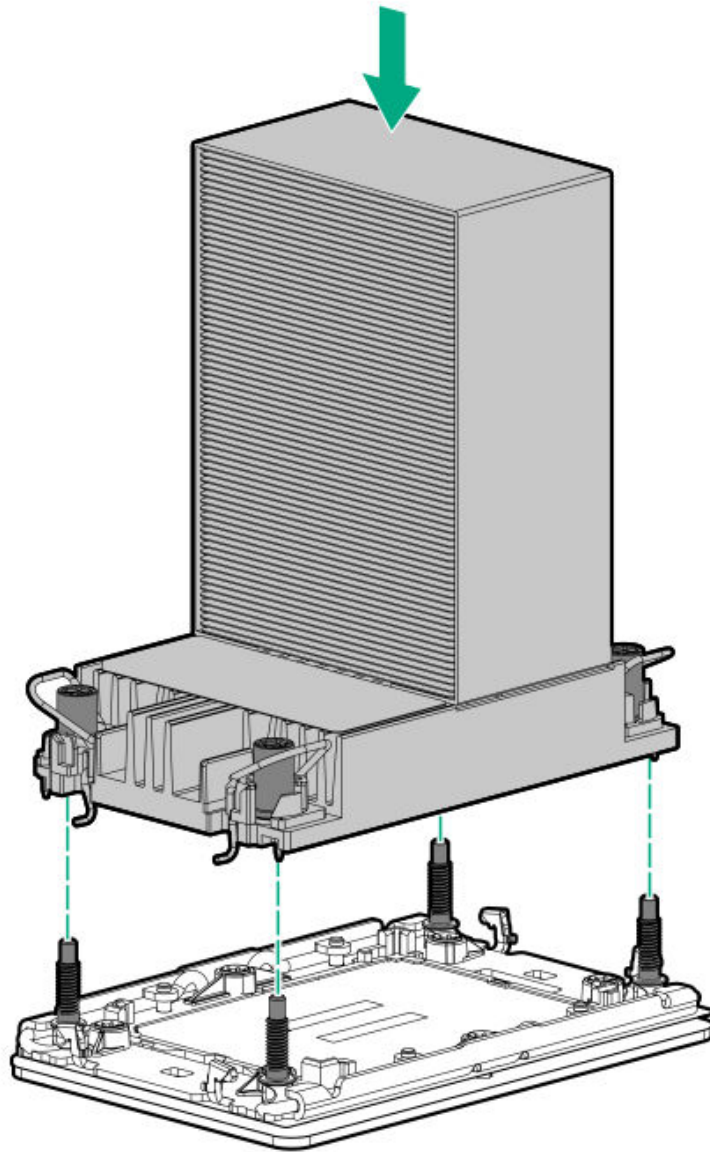

- Performance heatsink

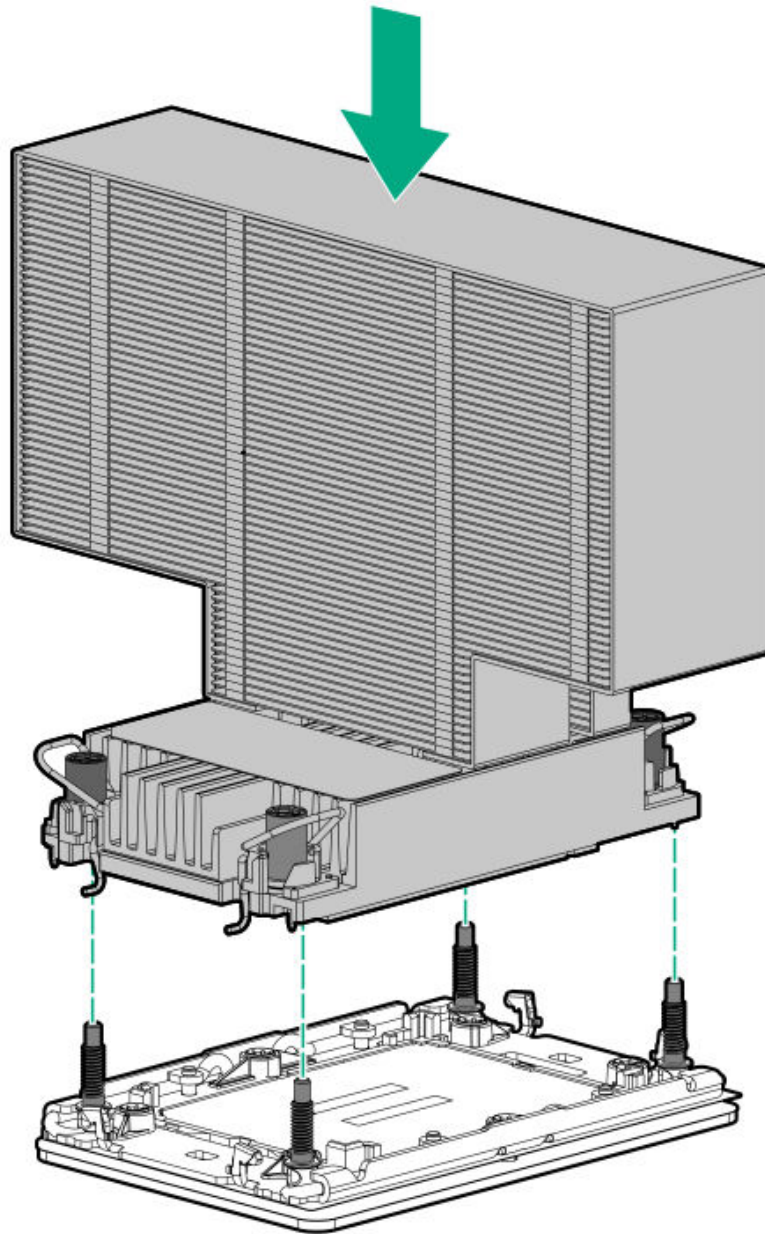

d. Set the anti-tilt wires to the locked position.

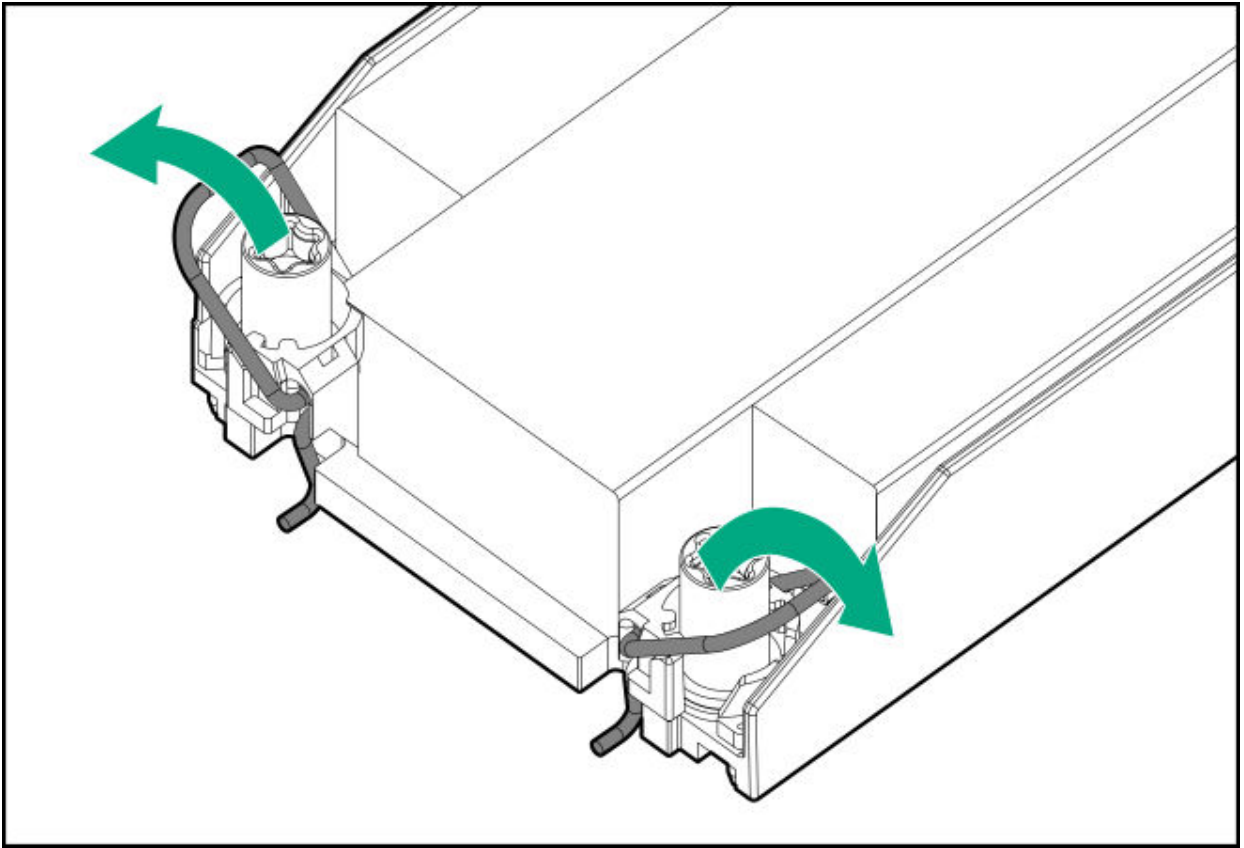

e. Tighten one pair of diagonally opposite heatsink screws, and then tighten the other pair of heatsink screws.

- Standard heatsink

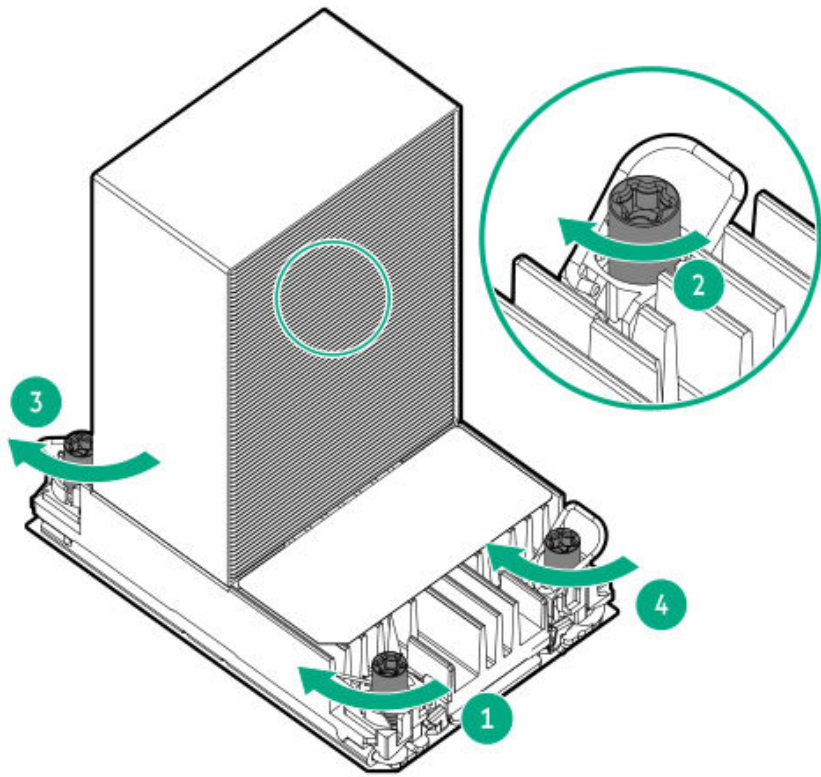

- Performance heatsink

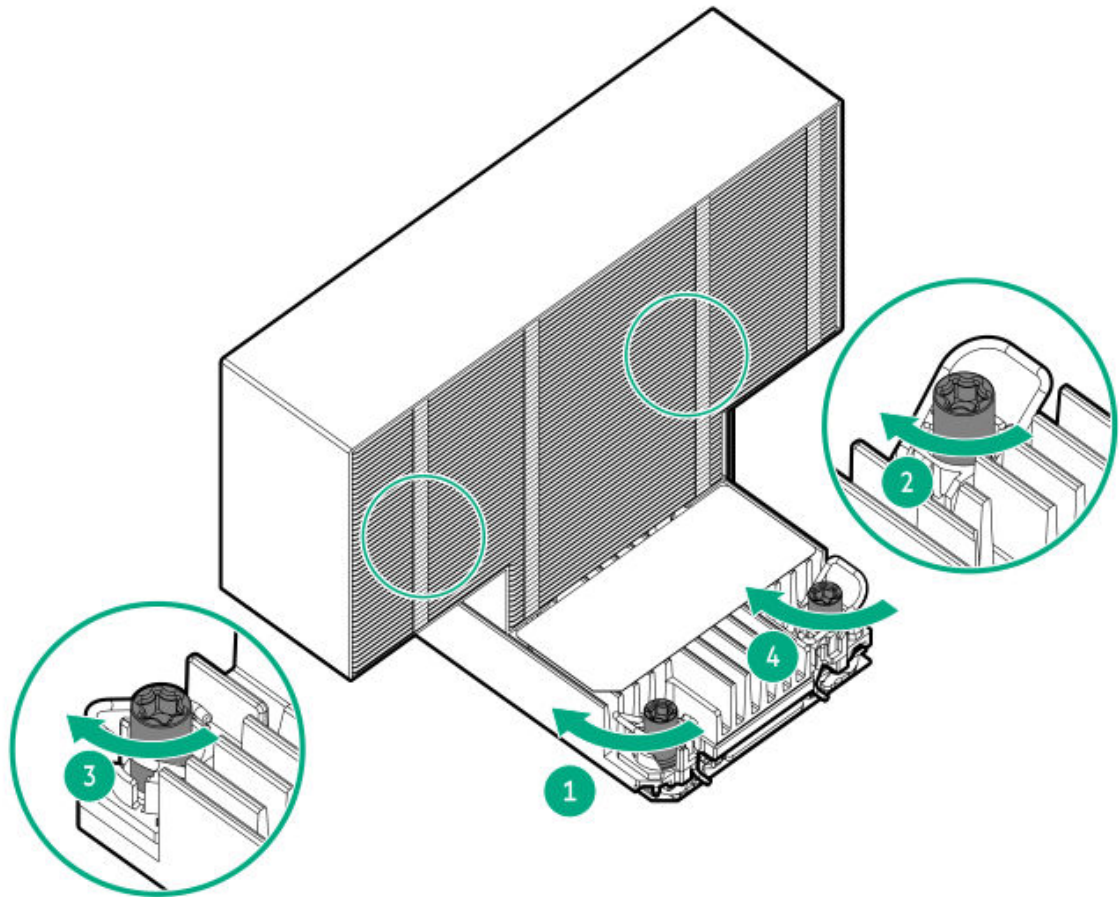

7. Install all removed components on the new system board.
8. Install the fan cage.
9. Install the access panel.
0. Lock the front bezel.
- .1. Do one of the following:
 - Orient the server back in tower mode.
 - Install the server into the rack.
- .2. Connect all peripheral cables to the server.
- .3. Connect each power cord to the server.
- .4. Connect each power cord to the power source.
- .5. Power up the server.

- .6. Make sure all firmware, including option cards and embedded devices, is updated to the same versions to ensure that the latest drivers are being used.
- .7. Re-enter any Secure Boot keys that were previously added in the Secure Boot configuration.
- .8. Re-enter the server serial number and product ID.
- .9. See the applicable OS documentation for procedures and recommendations on restoring the OS and accessing drive data.



CAUTION

(For Microsoft Windows only) After replacing the system board, we recommend using BitLocker Recovery to restore the OS and access drive data. The recovery key/password previously generated during the initial server installation and BitLocker setup is required to enter Recovery Mode.

For more information about BitLocker Recovery, see the [Microsoft website](#).

Results

The replacement procedure is complete.

Re-entering the server serial number and product ID

About this task

After replacing the system board, re-enter the system serial number and product ID.

Procedure

1. Access the UEFI System Utilities. During POST, press **F9**.
2. From the **System Utilities** screen, select **System Configuration > BIOS/Platform Configuration (RBSU) > Advanced Options > Advanced Service Options**.
3. Select **Serial Number**, and then press **Enter**.

The following warning appears:

```
The serial number is modified by qualified service personnel and must
match the serial number located on the chassis.
```

4. Click **OK**.
5. Type the serial number, and then press **Enter**.

6. Select **Product ID**, and then press **Enter**.

The following warning appears:

```
Product ID is modified only by qualified service personnel. This value  
must match the product ID located on the chassis.
```

7. Type the product ID, and then press **Enter**.
8. To confirm and save the settings, press **F12**.

The server automatically reboots.

Results

The installation procedure is complete.

System battery replacement

If the server no longer automatically displays the correct date and time, then replace the battery that provides power to the real-time clock. Under normal use, battery life is 5–10 years.

Subtopics

[System battery information](#)

[Removing and replacing the system battery](#)

System battery information

The server contains an internal lithium manganese dioxide, a vanadium pentoxide, or an alkaline battery that provides power to the real-time clock.



WARNING

If this battery is not properly handled, a risk of fire or burning exists. To reduce the risk of personal injury:

- Do not attempt to recharge the battery.
- Do not expose the battery to temperatures higher than 60°C (140°F).
- Do not expose the battery to low air pressure as it might lead to explosion or leakage of flammable liquid or gas.
- Do not disassemble, crush, puncture, short external contacts, or dispose of the battery in fire or water.

Removing and replacing the system battery

Prerequisites

Before you perform this procedure, make sure that you have a small flat-bladed, nonconductive tool available.

About this task

https://sketchfab.com/models/6f2a2a1a5c8540cb9a3adc740b055e0e/embed?ui_infos=0&ui_watermark=0&ui_help=0&ui_vr=0&ui_settings=0&ui_inspector=0&ui_hint=2&ui_color=01a982&ui_theme=dark&autostart=1&camera=0&



IMPORTANT

After replacing the system battery and applying power, wait for 10 minutes before powering on the server. This lead time is required for the server to reset and reinitialize the iLO configuration settings stored in SRAM.

Procedure

1. Power down the server.

2. Remove all power:
 - a. Disconnect each power cord from the power source.
 - b. Disconnect each power cord from the server.
3. Disconnect all peripheral cables from the server.
4. Do one of the following:
 - If the server is in tower mode, place the server on a flat, level surface with the access panel facing up.
 - If the server is in rack mode, remove the server from the rack.
5. Unlock the front bezel.
6. Remove the access panel.
7. Remove the primary riser cage.
8. Locate the battery on the system board.
9. Remove the system battery:
 - a. Use a small flat-bladed, nonconductive tool to press the battery latch.
 - b. Remove the system battery from the socket.

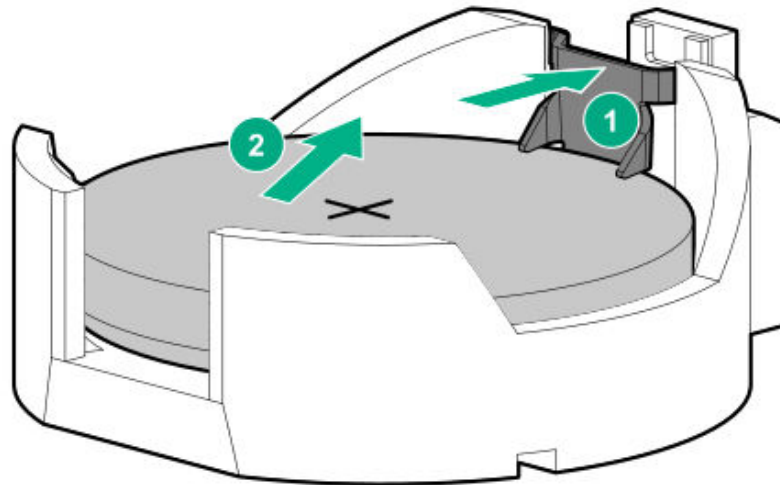

10. Install the system battery:
 - a. With the side of the battery showing the "+" sign facing up, insert the battery into the socket.
 - b. Press the system battery down until it clicks into place.

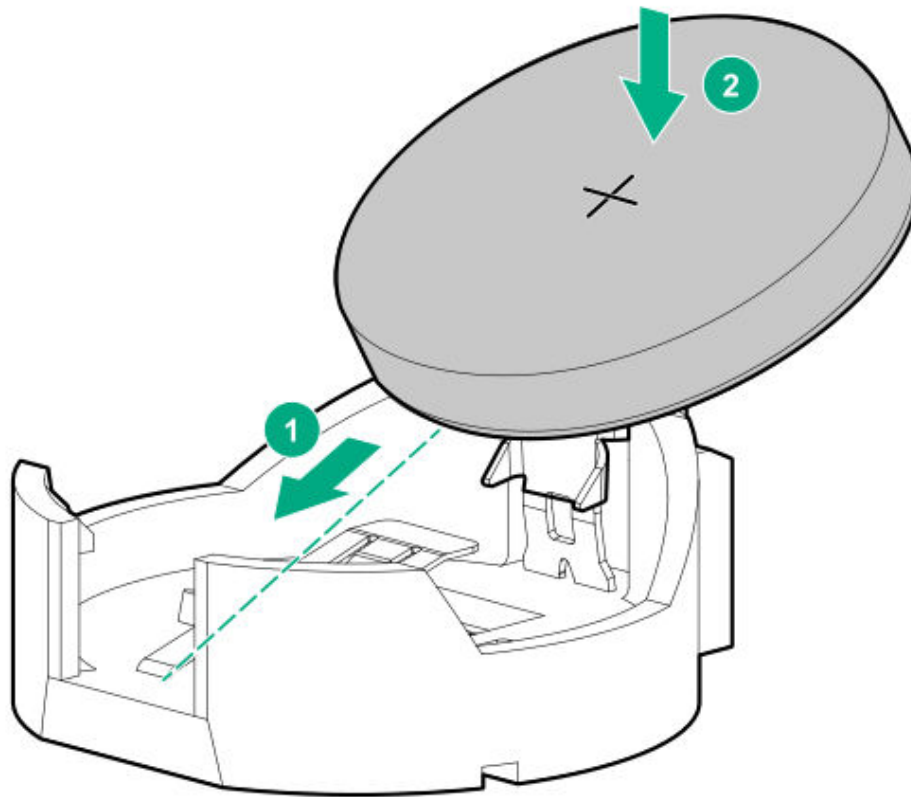

- .1. Install the secondary riser cage.
- .2. Install the access panel.
- .3. Do one of the following:
 - Orient the server back in tower mode.
 - Install the server into the rack.
- .4. Connect all peripheral cables to the server.
- .5. Connect each power cord to the server.
- .6. Connect each power cord to the power source.
- .7. Wait for 10 minutes for the server to reset and reinitialize the iLO configuration settings stored in SRAM.



IMPORTANT

If iLO security is disabled, the configuration will not be restored. To restore the configuration manually, see <https://www.hpe.com/support/hpeilodocs-quicklinks>.

- .8. Power up the server.
- .9. Properly dispose of the old battery.

For more information about proper battery disposal, contact an authorized reseller or an authorized service provider.

Results

The removal procedure is complete. To replace the component, reverse this procedure.

Component identification

This chapter describes the external and internal server features and components.

Subtopics

Front panel components

Front panel LEDs and button

Rear panel components

Rear panel LEDs

Component touchpoints

System board components

Fan bay numbering

Drive bay numbering

Drive backplane naming

HPE Basic Drive LED definitions

EDSFF SSD LED definitions

HPE NS204i-u Boot Device V2 components

HPE NS204i-u Boot Device V2 LED definitions

Riser board components

Riser slot numbering

Media device screws

Front panel components

4/8/12 LFF drive configuration

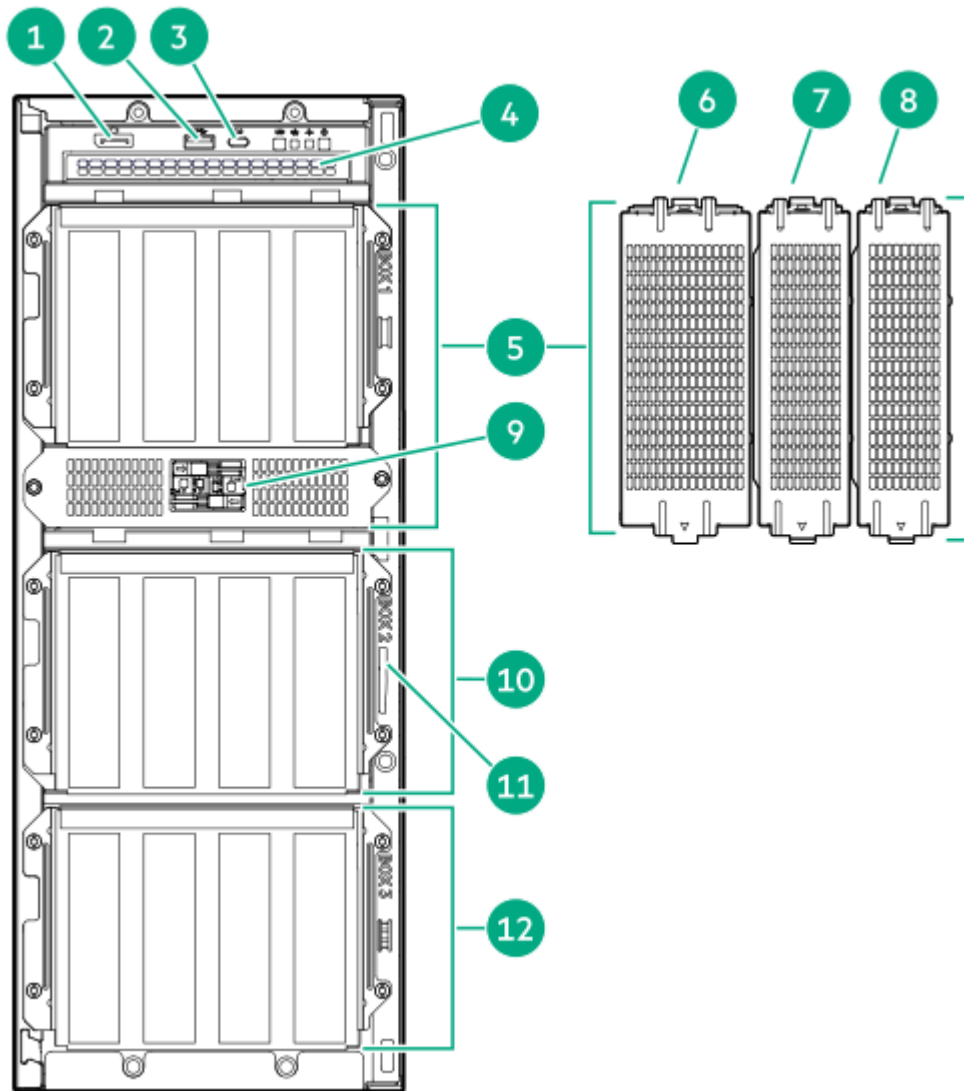

8/16/24 SFF drive configuration

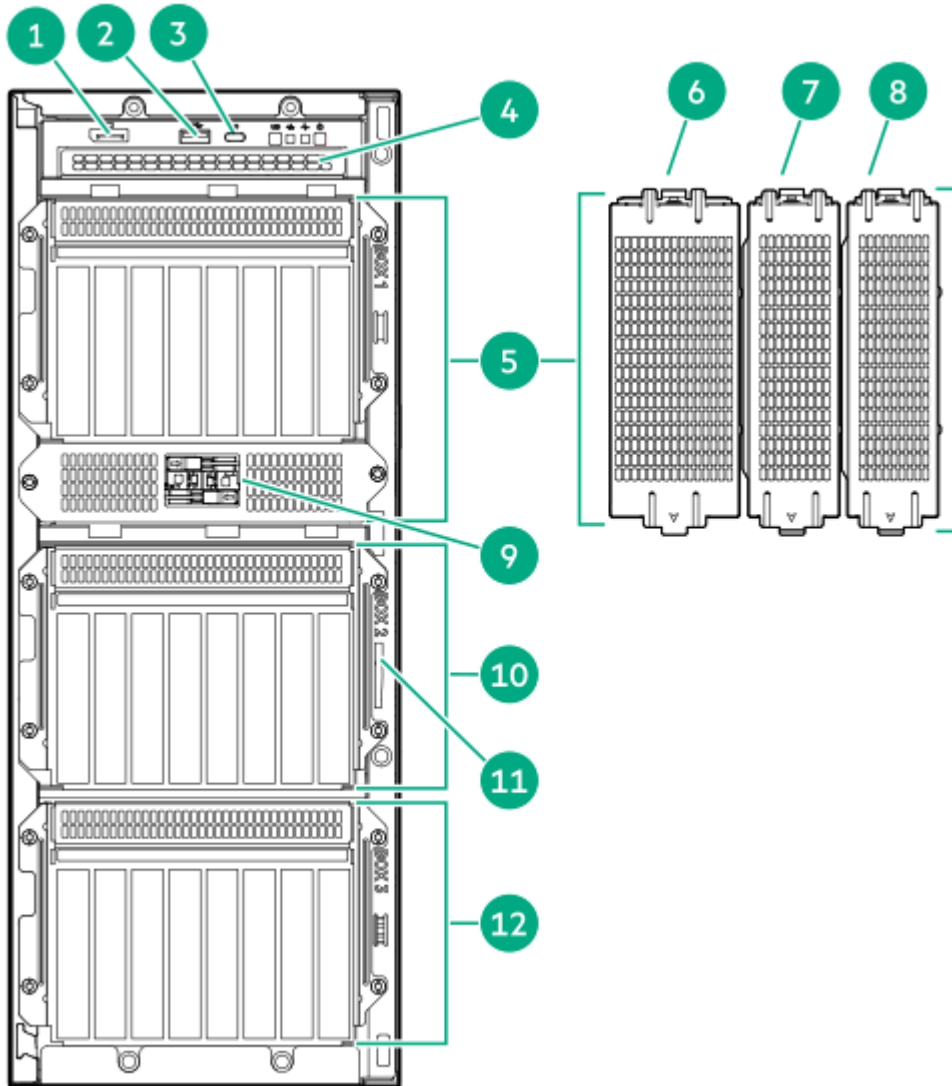

12 E3.S drive configuration

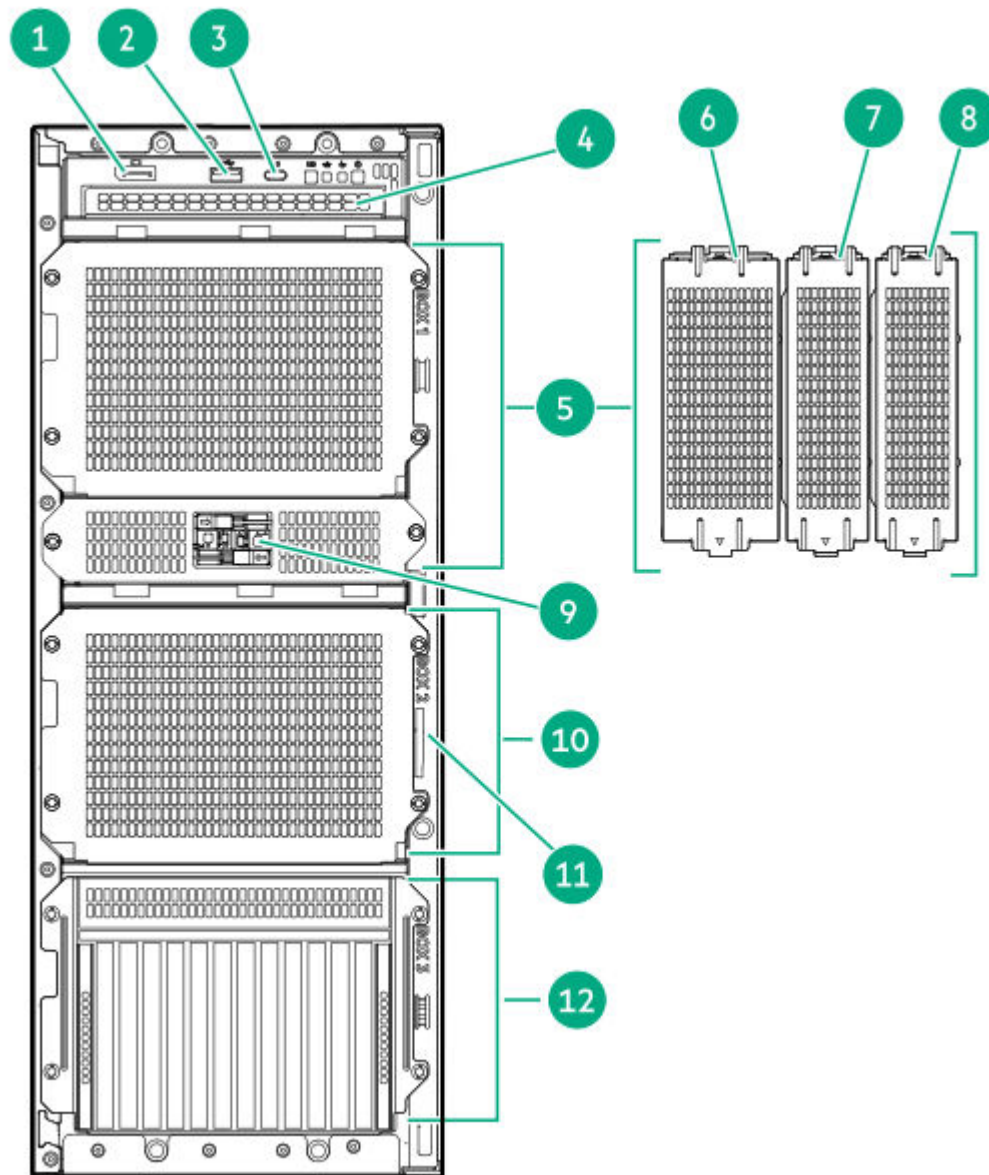

Item	Description
1	DisplayPort 1.1a
2	USB 3.2 Gen 1 port
3	iLO service port
4	Optical drive bay
5	Box 1 <u>1</u> <u>2</u>
6	Full-height media bay blank

Item	Description
7	Media bay 2
8	Media bay 1
9	NS204i-u device (optional)
10	Box 2 ¹ ₂
11	Serial number/iLO information pull tab ³ _—
12	Box 3 ⁴ ₅

¹ _— All three boxes support LFF and SFF drive cage options. This server supports mixed LFF + SFF hot-plug drive configurations.

² _— The x1 NVMe drives are supported in Box 1, 2, and 3.

³ _— The serial number/iLO information pull tab is double-sided. One side shows the server serial number and the customer asset tag label. The other side shows the default iLO account information.

⁴ _— E3.S drives are supported in Box 3. When the E3.S drives are installed, LFF/SFF drives are supported in Box 1 and 2. Two processors are required for E3.S drive installation.

⁵ _— The x4 NVMe drives are supported in Box 2 and 3 with a x4 cable and in Box 1, 2, and 3 with a x2 cable. The x4 NVMe drive backplane cannot be installed with other drive backplane types.

Front panel LEDs and button

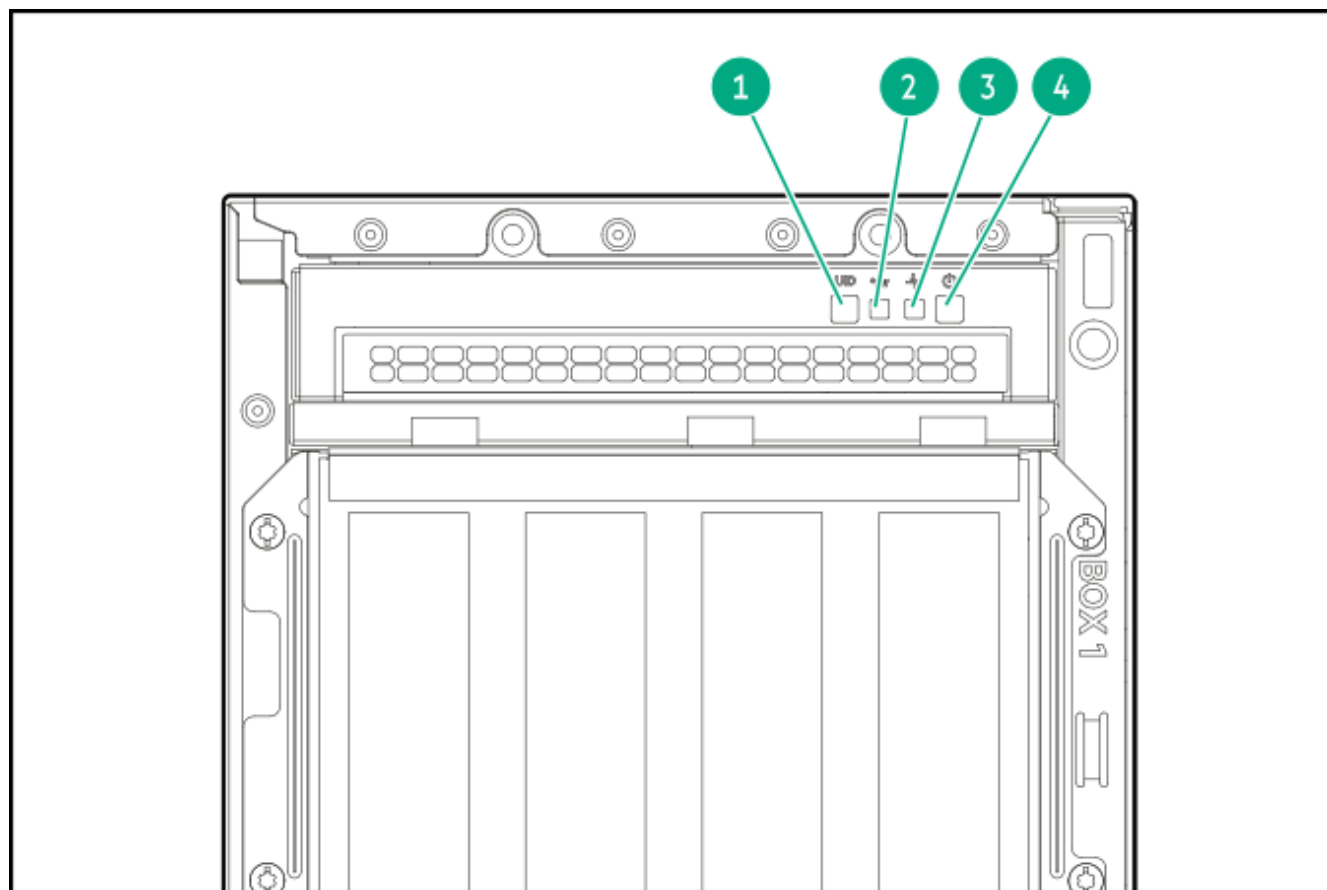

Item	Description	Status	Definition
1	UID button/LED ¹ ₁	Solid blue	Activated
		Flashing blue	<ul style="list-style-type: none"> 1 flash per second—Remote management or firmware upgrade in progress 4 flashes per second—iLO manual reboot sequence initiated 8 flashes per second—iLO manual reboot sequence in progress
		Off	Deactivated
2	NIC status LED ¹ ₁	Solid green	Linked to network
		Flashing green	Network active
		Off	No network activity
3	Health LED ¹ ₁	Solid green	Normal

Item	Description	Status	Definition
		Flashing green	iLO is rebooting
		Flashing amber	System degraded ²
		Flashing red	System critical ²
4	Power On/Standby button and system power LED ¹	Solid green	System on
		Flashing green	Performing power-on sequence
		Solid amber	System in standby
		Off	No power present ³

¹ When all LEDs described in this table flash simultaneously, a power fault has occurred. For more information, see [Front panel LED power fault codes](#).

² If the health LED indicates a degraded or critical state, review the system [Integrated Management Log \(IML\)](#) or use HPE iLO to review the system health status.

³ Facility power is not present, power cord is not attached, no power supplies are installed, power supply failure has occurred, or the front I/O cable is disconnected.

Subtopics

[Server UID LED](#)

[Viewing the Server Health Summary](#)

Server UID LED

The UID LED can be used to help an on-site technician quickly identify or locate a particular server when it is deployed in a dense rack with other equipment. It can also be used to identify if a remote management, firmware upgrade, or reboot sequence is in progress.

Viewing the Server Health Summary

Prerequisites

- An external monitor is connected.
- In the iLO web interface, the **Show Server Health on External Monitor** feature is enabled on the **Access Settings** page.

About this task

If the server does not power on, use the UID button to display the iLO **Server Health Summary** screen on an external monitor. This function works when the server is powered on or off.

For more information, see the iLO troubleshooting guide on the [Hewlett Packard Enterprise website](#).

Procedure

1. Press and release the UID button.



CAUTION

Be sure to press and release the UID button. Pressing the UID button at any time for more than five seconds will initiate a graceful iLO reboot or a hardware iLO reboot. Data loss or NVRAM corruption might occur during a hardware iLO reboot.

The **Server Health Summary** screen displays on the external monitor.

2. Press the UID button again to close the **Server Health Summary** screen.

Rear panel components

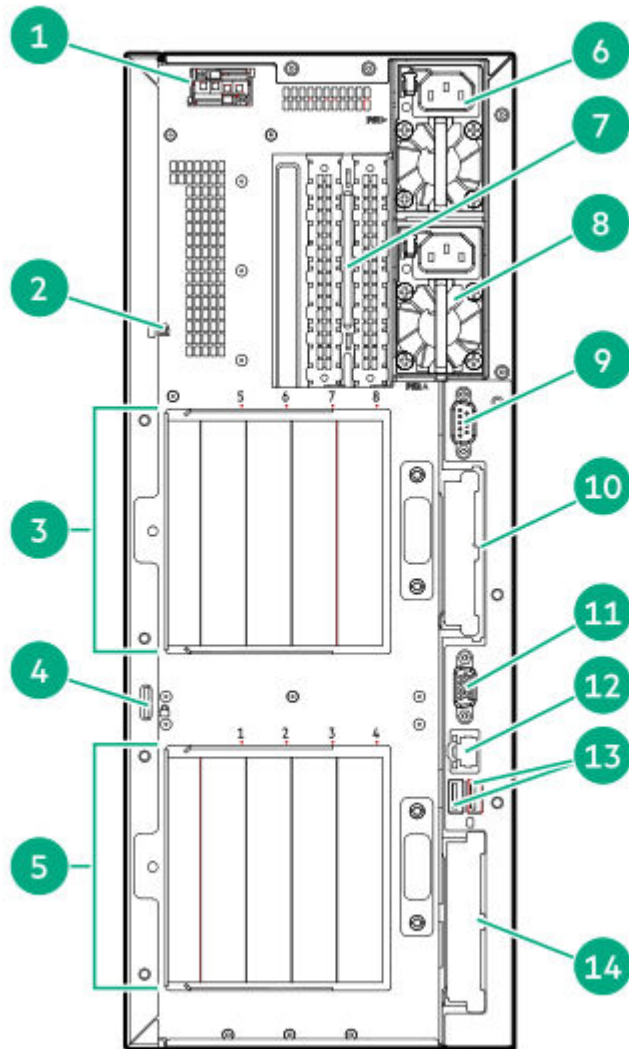

Item	Description
1	NS204i-u device (optional)
2	Kensington security slot
3	Slots 5–8 PCIe5 (secondary riser) ¹
4	Padlock eye
5	Slots 1–4 PCIe5 (primary riser)
6	Flexible Slot power supply 1
7	Slots 9–10 PCIe5 (tertiary riser) ¹
8	Flexible Slot power supply 2 (optional)

Item	Description
9	VGA port
10	Slot 15 OCP B PCIe5 x8/x16 ²
11	Serial port (optional)
12	iLO dedicated network port
13	USB 3.2 Gen 1 ports (2)
14	Slot 14 OCP A PCIe5 x8/x16 ³

¹ The PCIe signal from the secondary and tertiary riser requires that two processors are installed.

² This slot requires an OCP x8 or x16 bandwidth enablement cable option to function.

³ By default, this slot operates at x8 bandwidth speed. To enable x16 configuration, install the OCP bandwidth upgrade cable option.

Rear panel LEDs

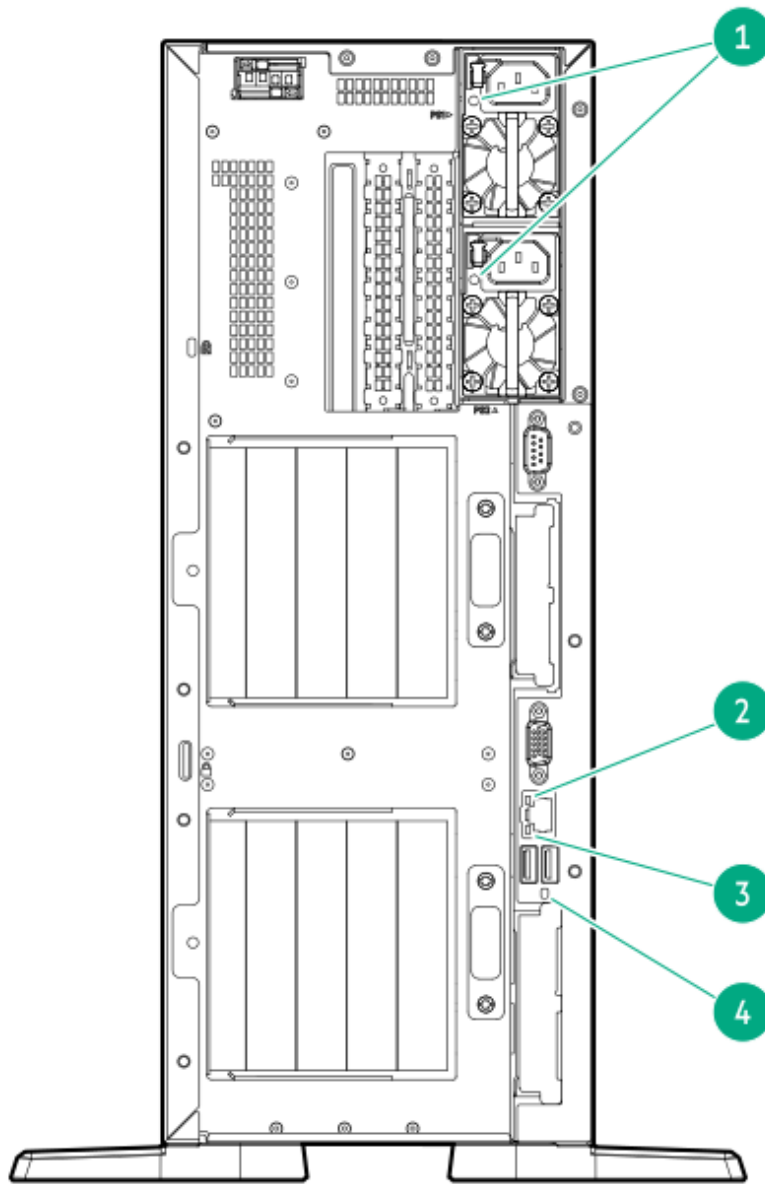

Item	Description	Status	Definition
1	Power supply	Solid green	The power supply is operating normally.
		Off	One or more of the following conditions exists: <ul style="list-style-type: none"> • Power is unavailable. • Power supply failure • Power supply is in standby mode. • Power supply error

Item	Description	Status	Definition
			<ul style="list-style-type: none"> Front I/O cable is disconnected.
2	iLO status	Solid green	Linked to network
		Flashing green	Network active
		Off	No network activity
3	iLO link	Solid green	Network link
		Off	No network link
4	UID	Solid blue	Activated
		Flashing blue	<ul style="list-style-type: none"> 1 flash per second—Remote management or firmware upgrade in progress 4 flashes per sec—iLO manual reboot sequence initiated 8 flashes per sec—iLO manual reboot sequence in progress
		Off	Deactivated

Component touchpoints

Certain components are color-coded. These colors represent the recommended touch areas for a removal process and indicate whether components require a system shutdown before removal.

The following diagrams are examples only.

HPE hot-plug red

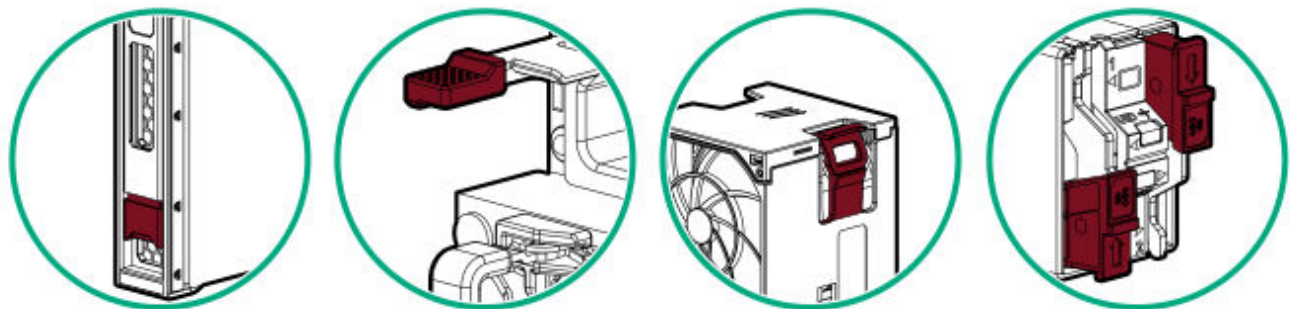

Hot-plug red indicates hot-pluggable components. These components can be removed and installed while the system is running, and doing so will not result in a system shutdown.

Component examples:

- Power supplies in a redundant power configuration
- Hot-plug fans
- Hot-plug drives
- M.2 SSDs in a hot-plug boot device

HPE touchpoint blue

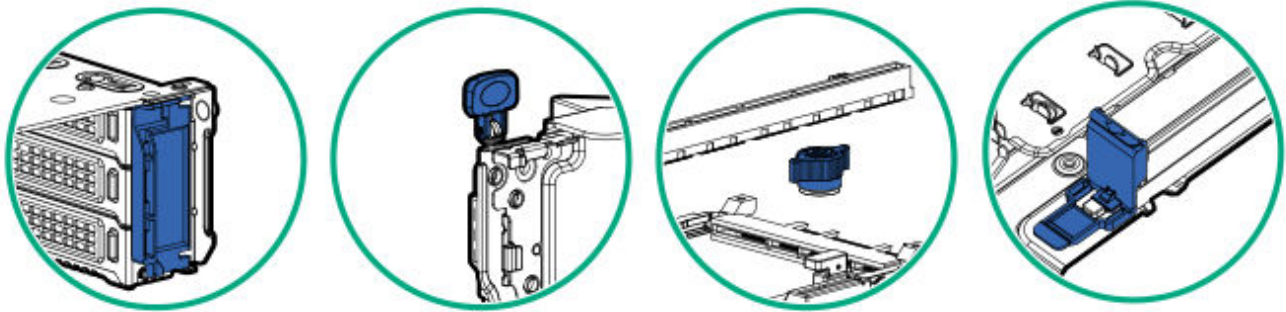

Touchpoint blue indicates cold-pluggable components. These components require a system shutdown. Failure to do so might result in system failure or data loss. Cold-pluggable components might also indicate touchpoints on non-electrical components.

Component examples:

- Storage devices
- Fan cages
- System boards
- Energy packs

System board components

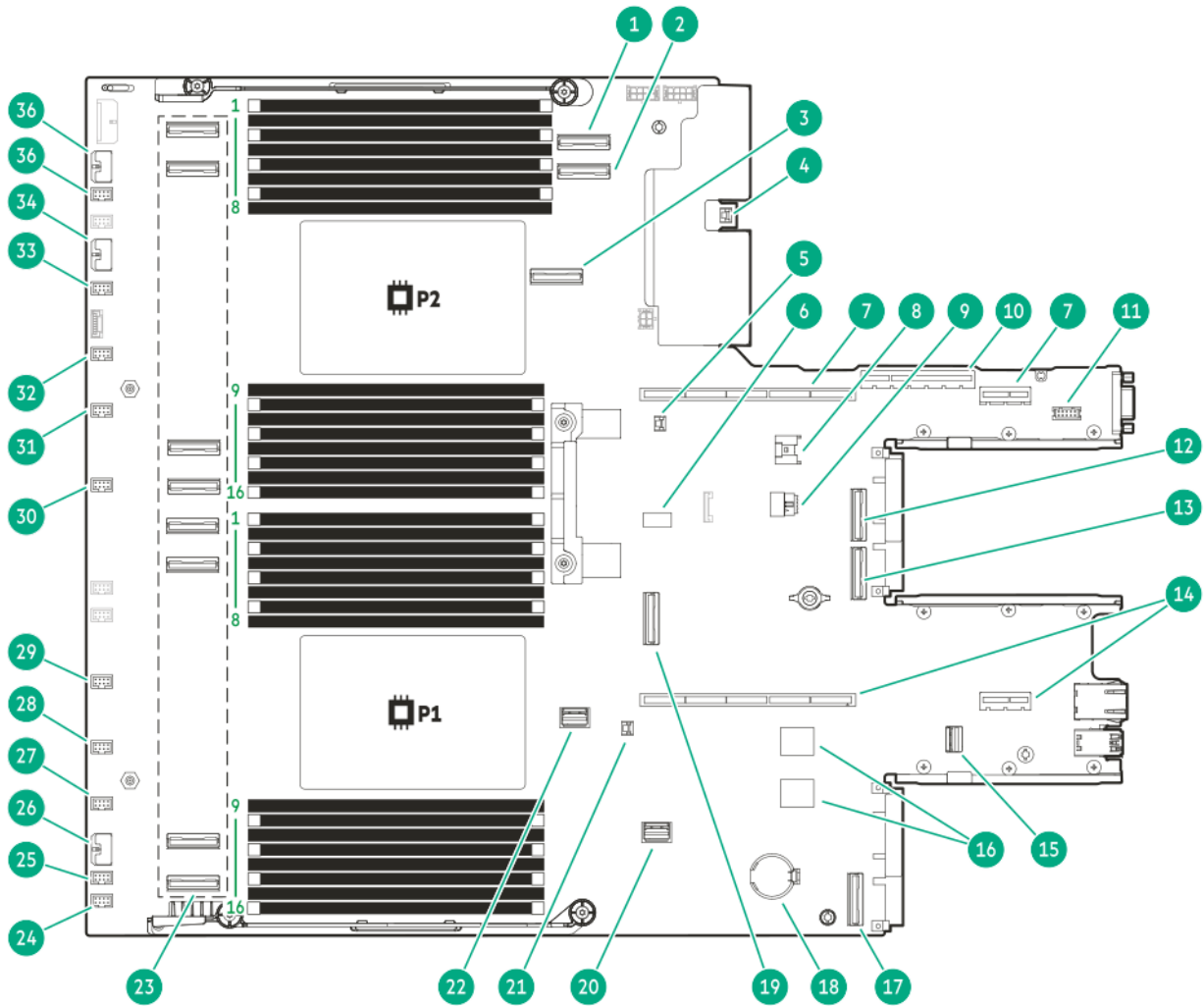

Item	Description
1	M-XIO port 9
2	M-XIO port 10
3	M-XIO port 11
4	Chassis intrusion detection switch connector
5	OCF slot B storage backup power connector
6	System maintenance switch
7	Secondary riser connectors
8	Energy pack connector
9	NS204i-u power connector

Item	Description
10	Tertiary riser sideband connector
11	Serial port cable connector
12	OCP B internal port 1
13	OCP B internal port 2
14	Primary riser connectors
15	DisplayPort & iLO service port connector
16	Dual USB 3.2 Gen 1 ports
17	OCP A internal port 1
18	System battery
19	M-XIO port 12
20	Front I/O connector
21	OCP slot A storage backup power connector
22	NS204i-u signal connector
23	M-XIO ports ¹ ₋
24	Fan connector 10 ² ₋
25	Fan connector 4 ² ₋
26	Drive box 3 power connector
27	Fan connector 8 ² ₋
28	Fan connector 7 ² ₋
29	Fan connector 3 ² ₋
30	Fan connector 2 ² ₋
31	Fan connector 6 ² ₋
32	Fan connector 5 ² ₋
33	Fan connector 1 ² ₋
34	Drive box 2 power connector
35	Fan connector 9 ² ₋
36	Drive box 1 power connector

¹ These M-XIO ports are numbered 8-1 from top to bottom.

²₋ The silkscreen markers on the system board do not match the actual fan numbering map for this server.

Subtopics

System maintenance switch

DIMM label identification

DIMM slot numbering

Heatsink and processor socket components

System maintenance switch

The system maintenance switch is a DIP switch block on the system board used during service and troubleshooting to temporarily override security or configuration settings. Each switch has an OFF (default) and ON position that enables a specific maintenance function.

To locate the system maintenance switch on your server, see [System board components](#).

Position	Default	Function
S1 ¹ / _—	Off	<ul style="list-style-type: none">Off—iLO 7 security is enabled.On—iLO 7 security is disabled.
S2	Off	Reserved
S3	Off	Reserved
S4	Off	Reserved
S5 ¹ / _—	Off	<ul style="list-style-type: none">Off—Power-on password is enabled.On—Power-on password is disabled.
S6 ^{1, 2, 3} / _{—, —, —}	Off	<ul style="list-style-type: none">Off—No functionOn—Restore default manufacturing settings
S7	Off	Reserved
S8	Off	Reserved
S9	Off	Reserved
S10	Off	Reserved
S11	Off	Reserved
S12	Off	Reserved

¹/_— To access the redundant ROM, set S1, S5, and S6 to On.

²/_— When the system maintenance switch position 6 is set to the On position, the system is prepared to restore all configuration settings to their manufacturing defaults.

- 3 When the system maintenance switch position 6 is set to the On position and Secure Boot is enabled, some configurations cannot be restored. For more information, see [Configuring the server](#).

DIMM label identification

To determine DIMM characteristics, see the label attached to the DIMM. The information in this section helps you to use the label to locate specific information about the DIMM.

For more information about product features, specifications, options, configurations, and compatibility, see the HPE DDR5 SmartMemory QuickSpecs:

<https://www.hpe.com/docs/server-memory>

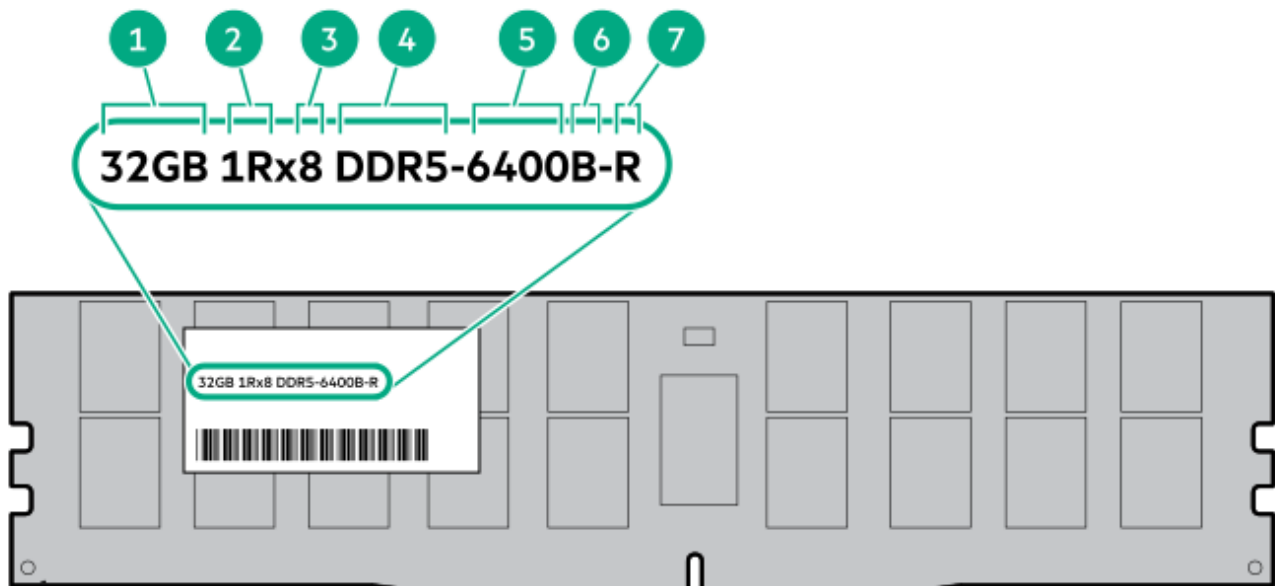

Item	Description	Example
1	Capacity*	16 GB 32 GB 64 GB 96 GB 128 GB 256 GB
2	Rank	1R—Single rank

Item	Description	Example
		2R—Dual rank 4R—Quad rank
3	Data width on DRAM	x4—4-bit x8—8-bit
4	Memory generation	PC5—DDR5
5	Maximum memory speed*	6400 MT/s
6	CAS latency	B—42-42-42
7	DIMM type	R—RDIMM (registered)

* The maximum memory speed and capacity is a function of the memory type, memory configuration, and processor model.

DIMM slot numbering

The arrow points to the front of the server.

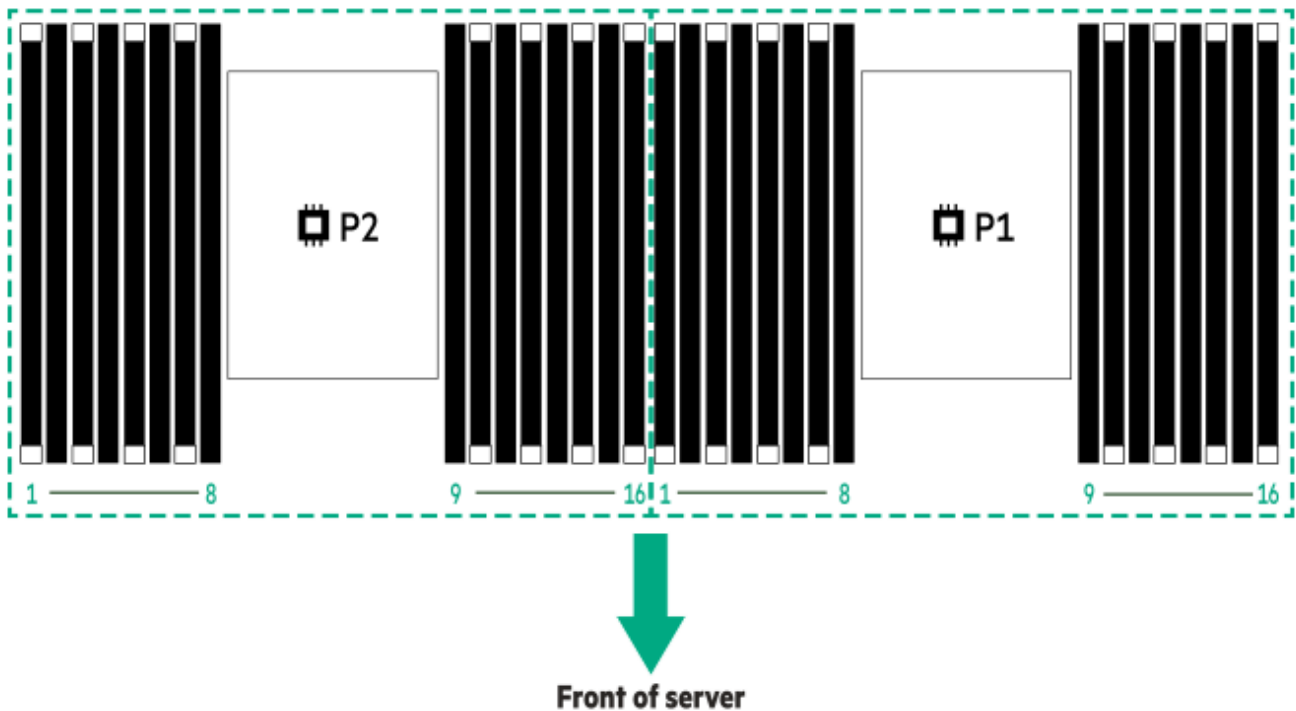

Heatsink and processor socket components

A standard heatsink is shown. Your heatsink might look different.

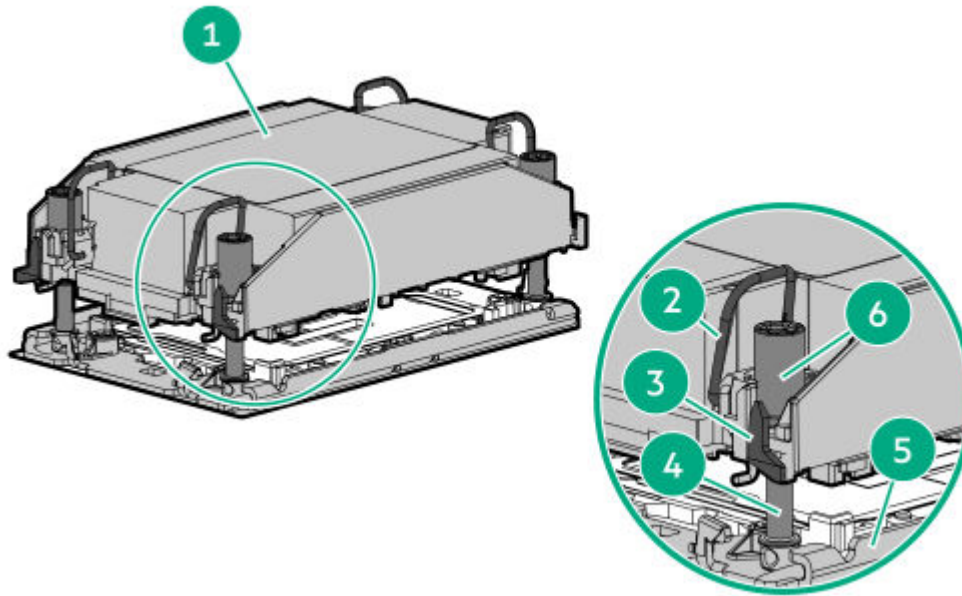

Item	Description
1	Processor-heat sink module *
2	Anti-tilt wires
3	Processor carrier release tabs
4	Bolster plate guide posts
5	Bolster plate
6	Heatsink screws

* This module consists of the heatsink attached to the processor that is already secured in its carrier.

Fan bay numbering

For more information on fan requirements for specific hardware configurations, see [Fan population](#).



Drive bay numbering



CAUTION

When a server is purchased without any drive installed, some drive bays might be empty while other drive bays might be populated with drive blanks. To maintain proper system cooling, do not operate the server without a drive or a drive blank installed.

Subtopics

[LFF drive bay numbering](#)

[SFF drive bay numbering](#)

[Mixed drive bay numbering](#)

[E3.S drive bay numbering](#)

LFF drive bay numbering

LFF drive box uses the 4 LFF 12G x1 SAS / SATA UBM3 drive backplane.

For more information on the drive backplane description, see [Drive backplane naming](#).

Tower orientation

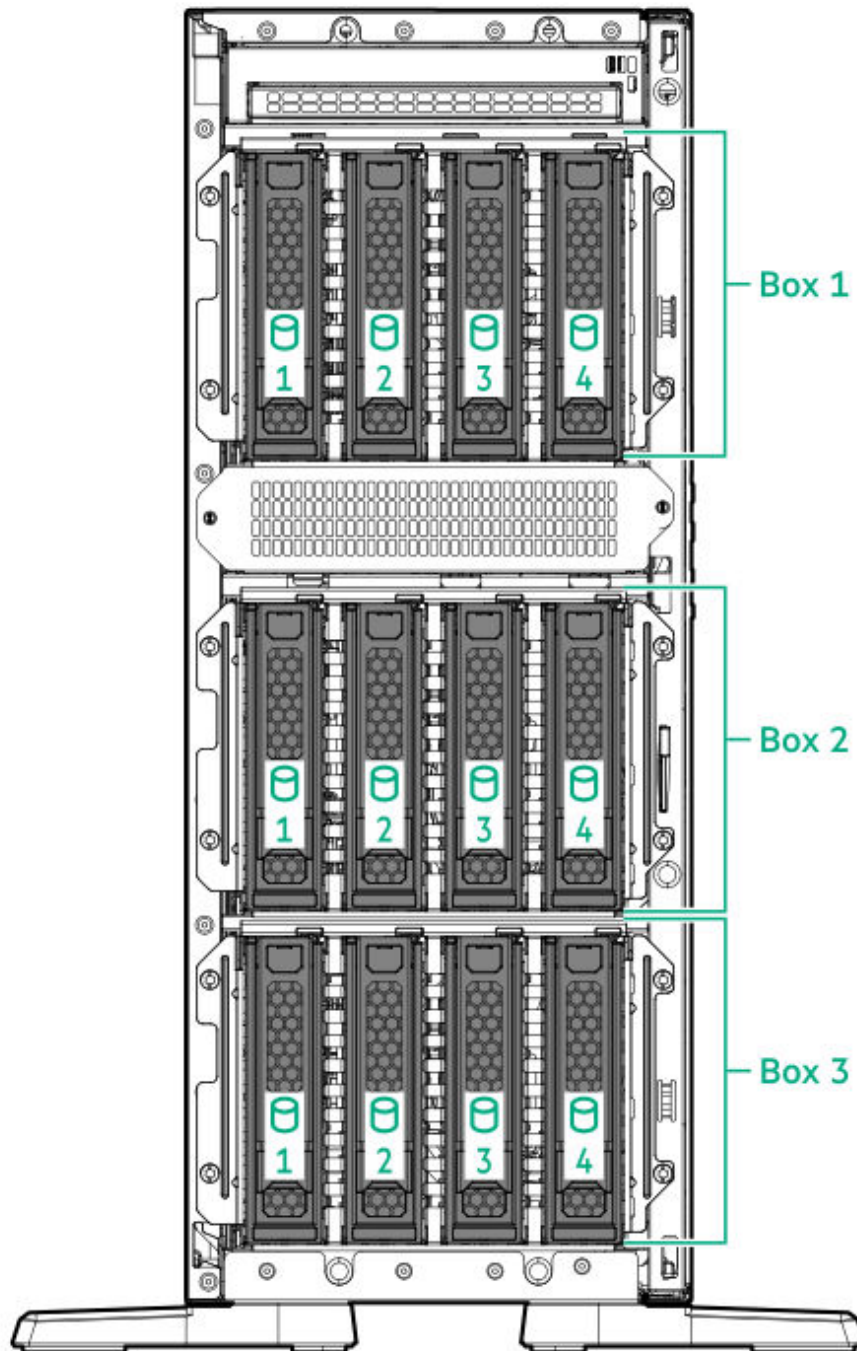

Rack orientation

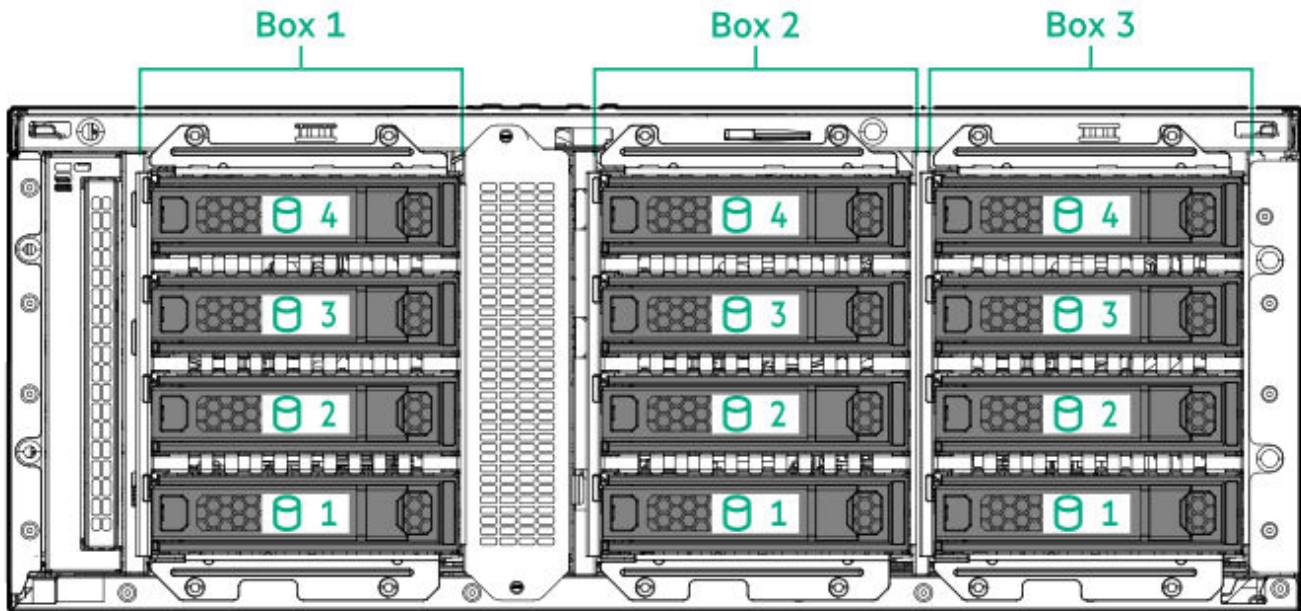

SFF drive bay numbering

The following drive backplane options are supported in SFF drive configurations:

- 8 SFF 24G x1 U.3 NVMe / SAS UBM3 BC
- 8 SFF 24G x1 U.3 NVMe / SAS UBM6 BC
- 8 SFF 24G x4 U.3 NVMe UBM3 BC
- 8 SFF 24G x4 U.3 NVMe UBM6 BC

For more information on the drive backplane description, see [Drive backplane naming convention](#).

Tower orientation

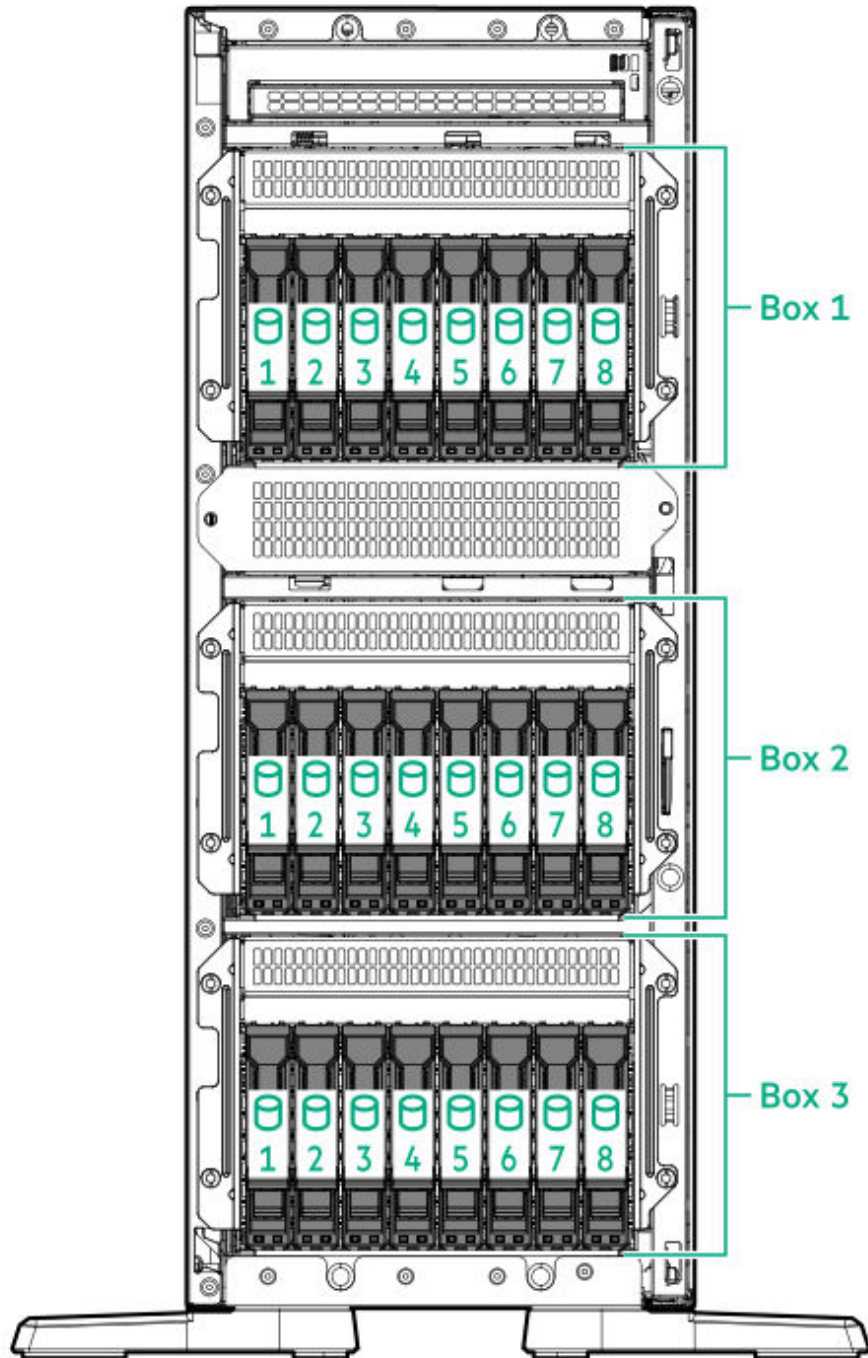

Rack orientation

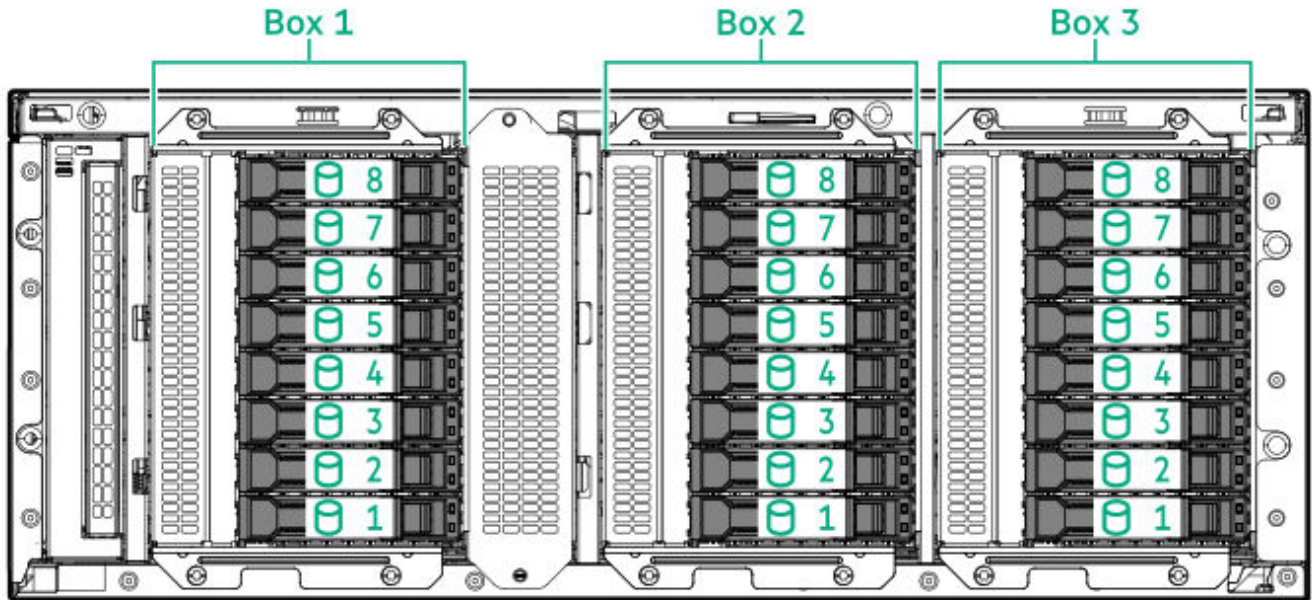

Mixed drive bay numbering

This server supports the following mixed hot-plug drive configurations.

4 LFF + 8 SFF

Tower orientation

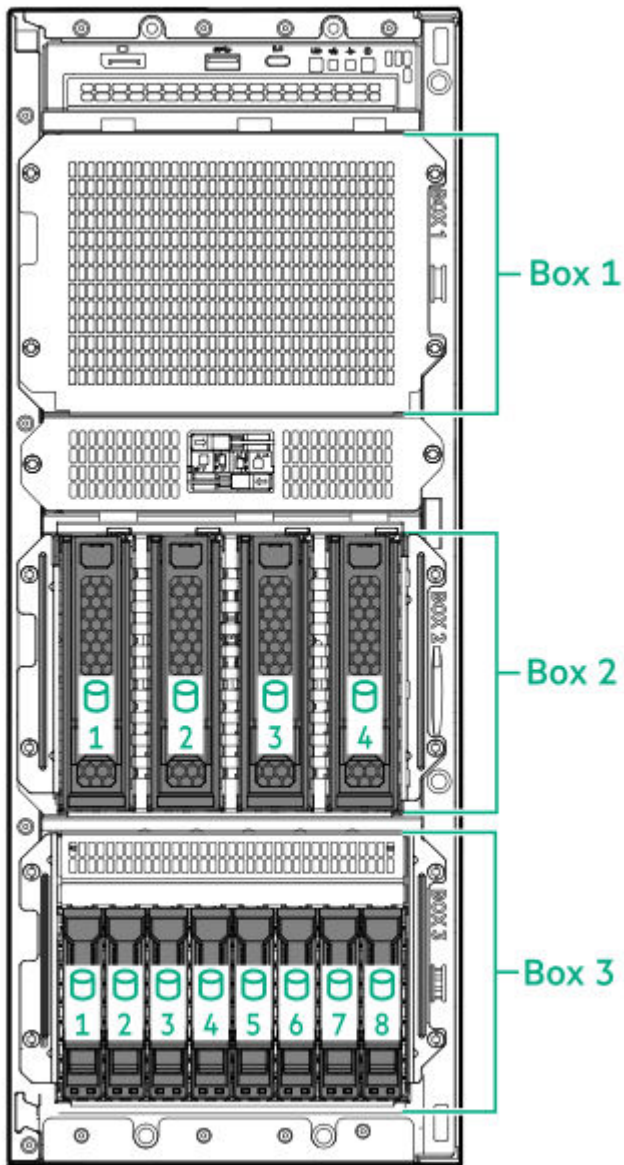

Rack orientation

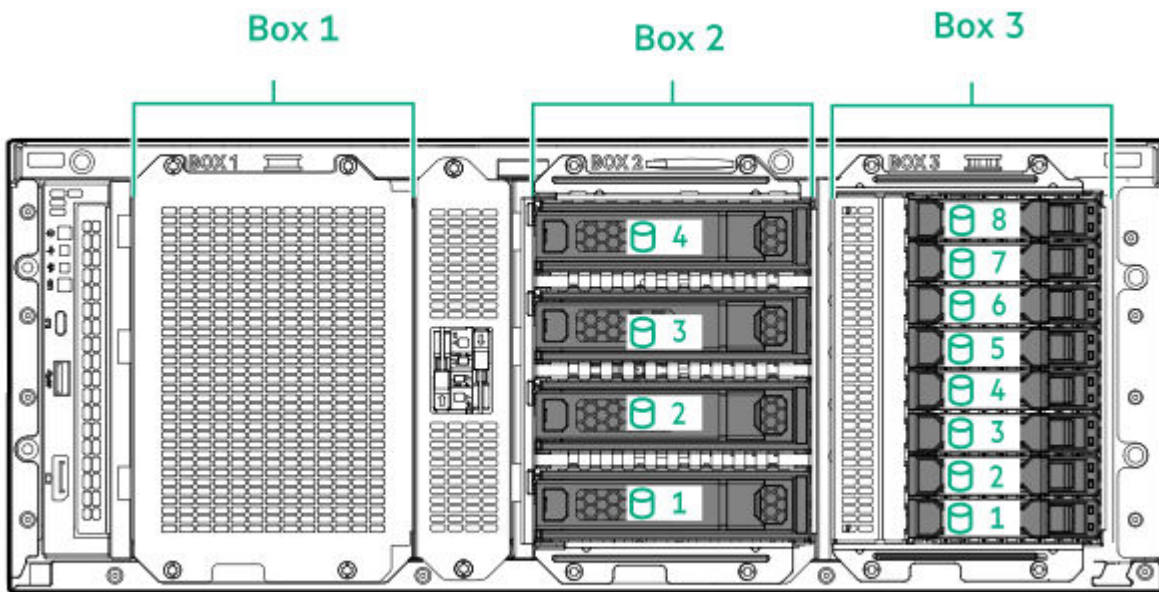

4 LFF + 16 SFF

Tower orientation

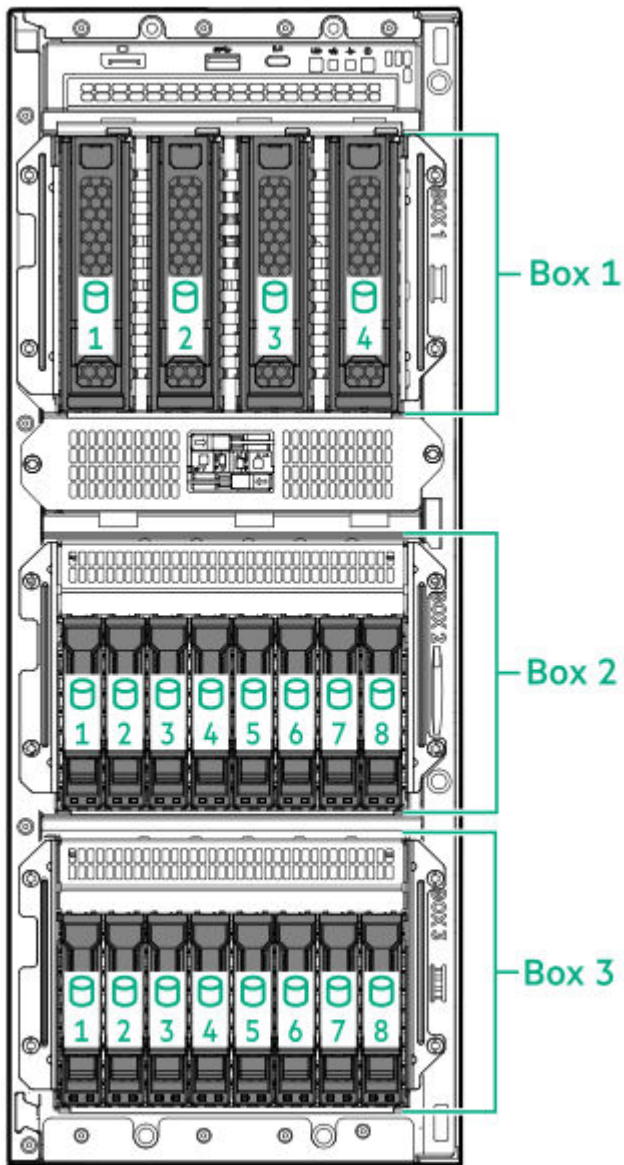

Rack orientation

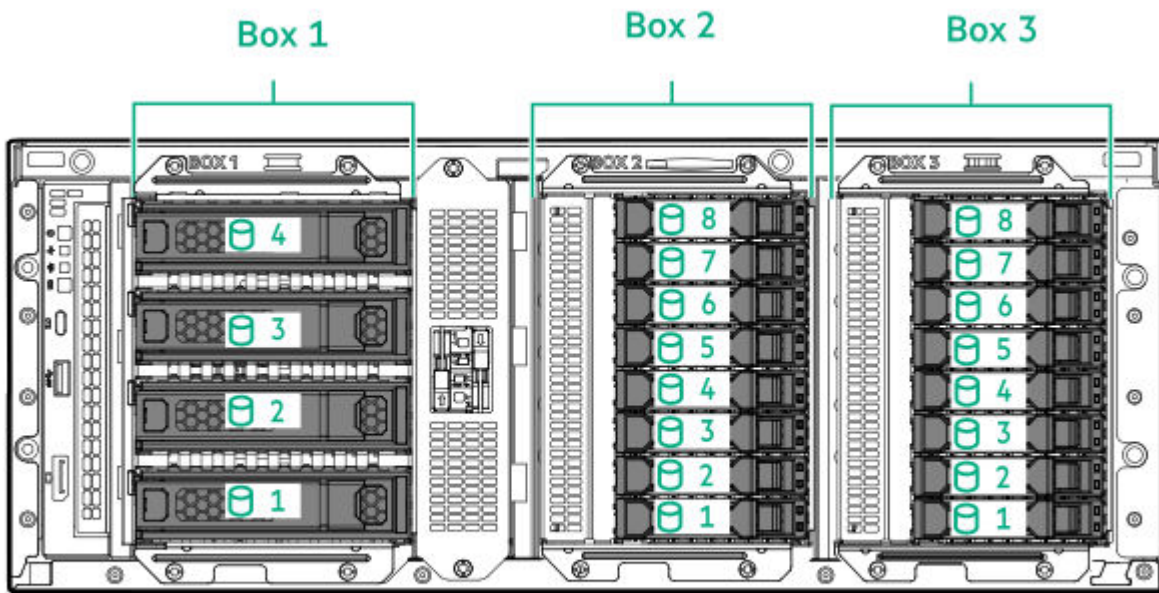

8 LFF + 8 SFF

Tower orientation

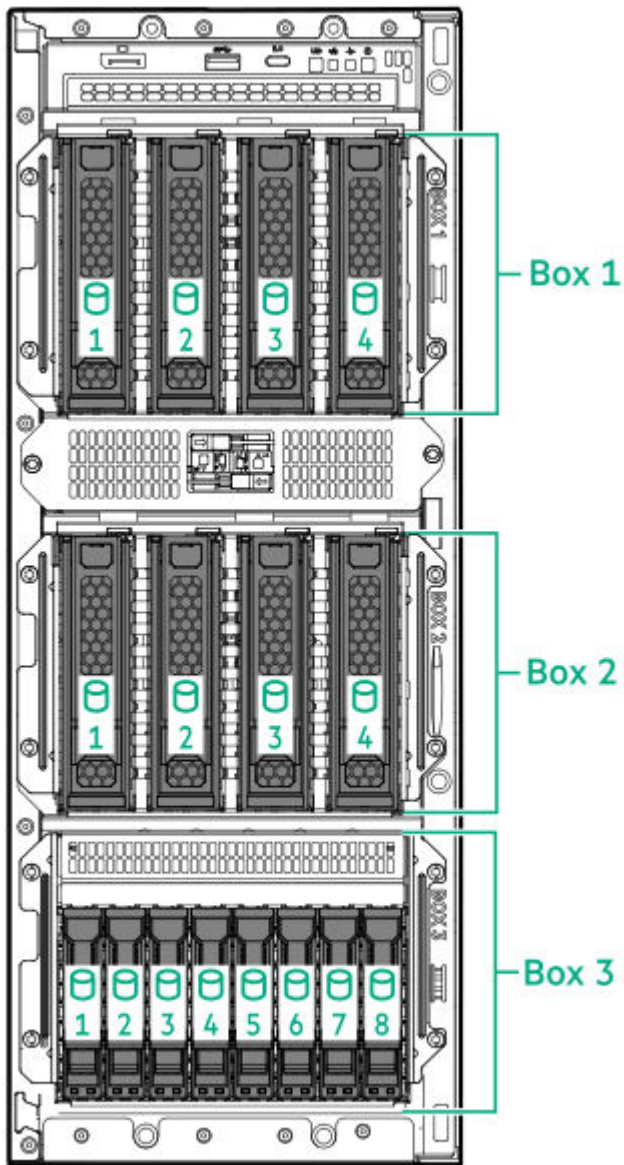

Rack orientation

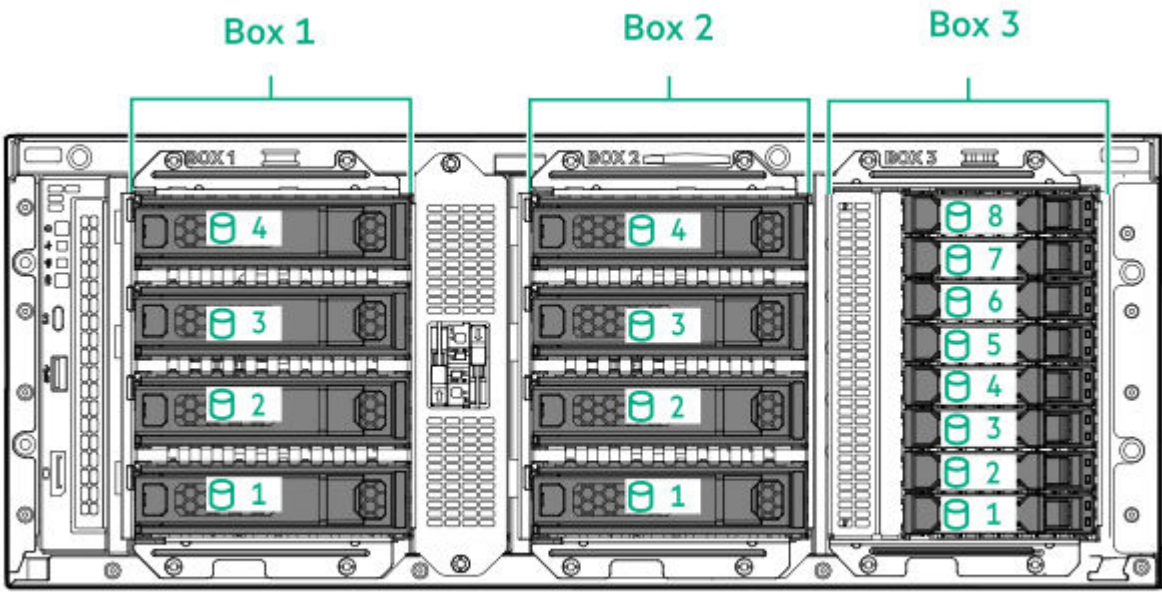

8 LFF + 12 E3.S

Tower orientation

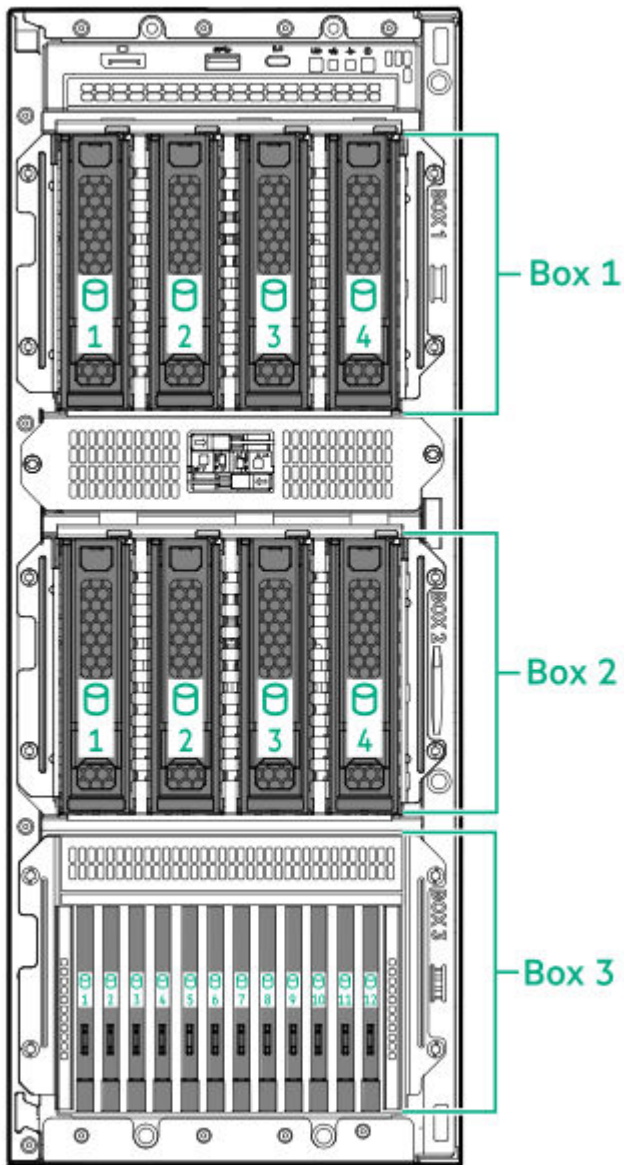

Rack orientation

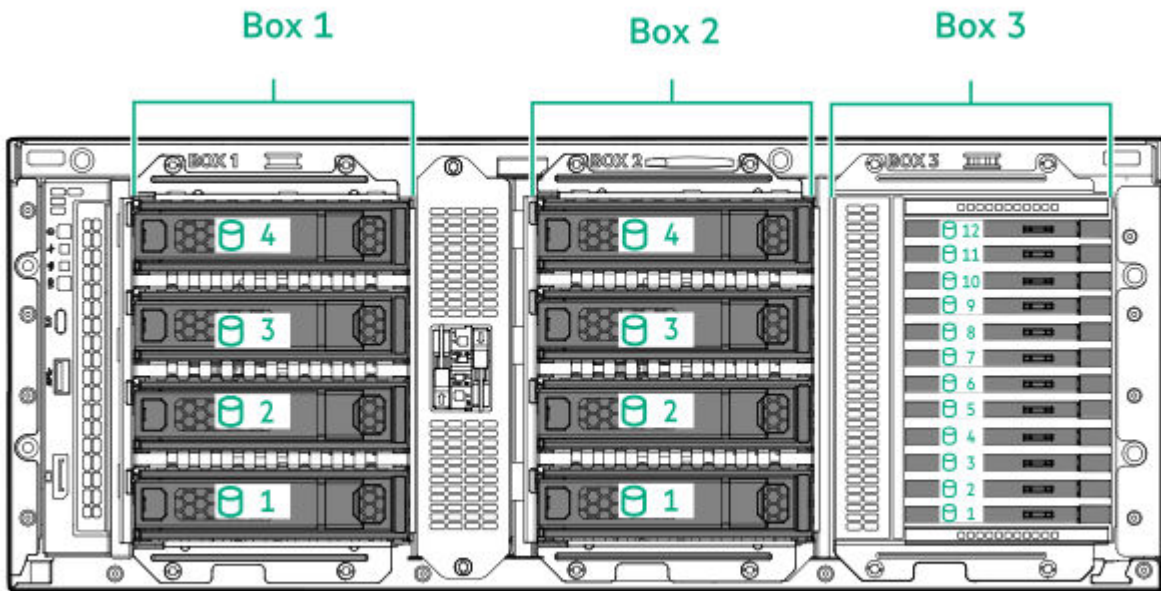

4 LFF + 12 E3.S

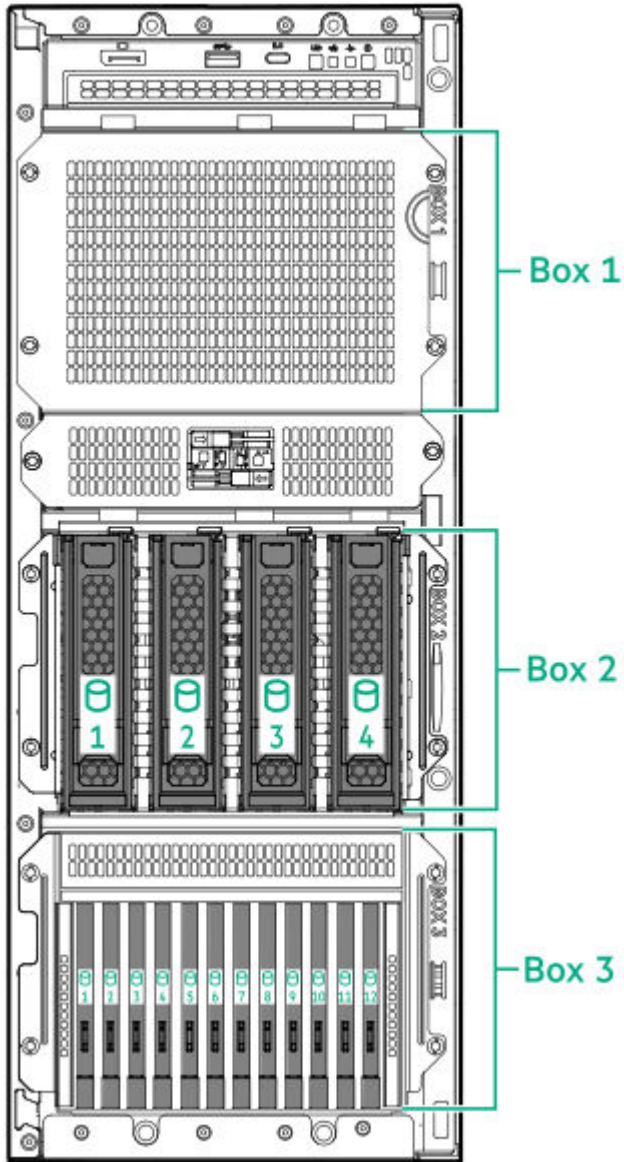

Rack orientation

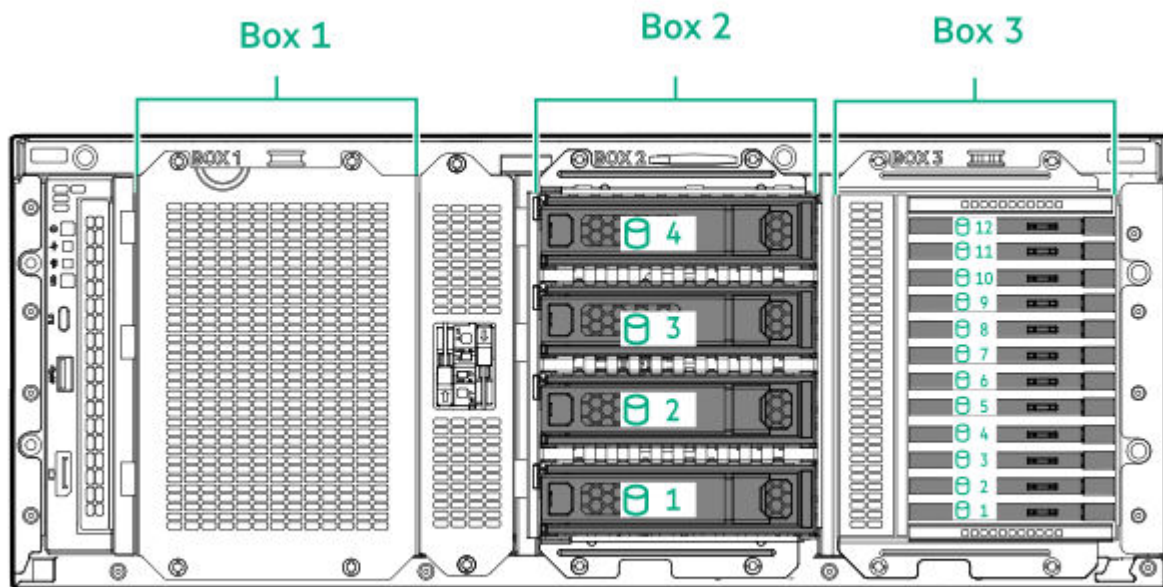

4 LFF + 8 SFF + 12 E3.S

Tower orientation

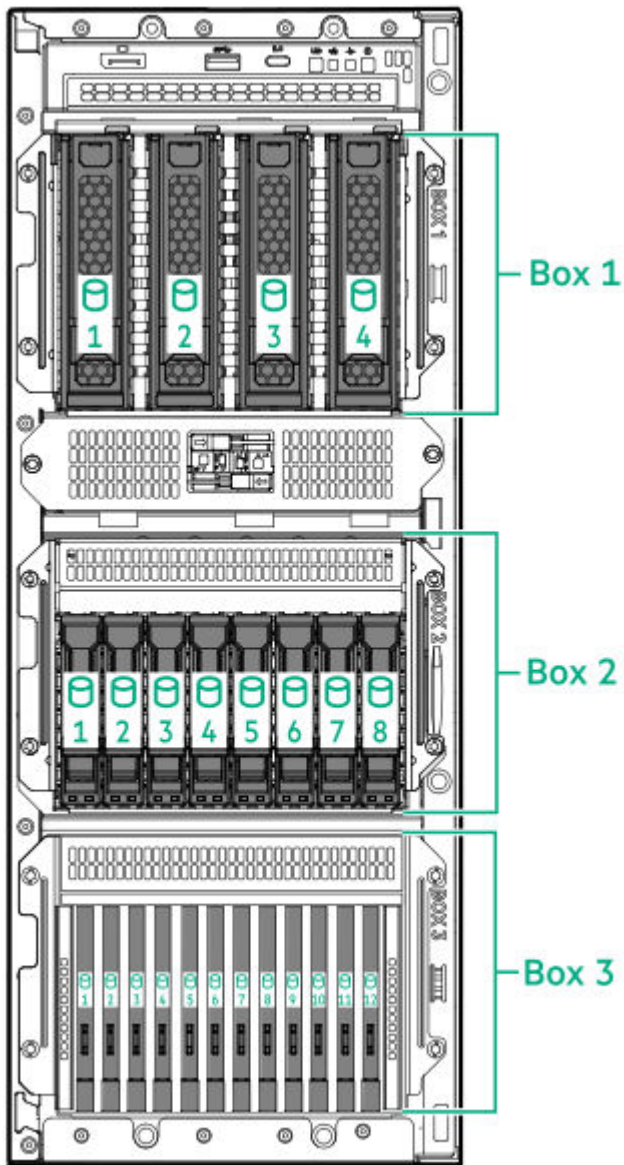

Rack orientation

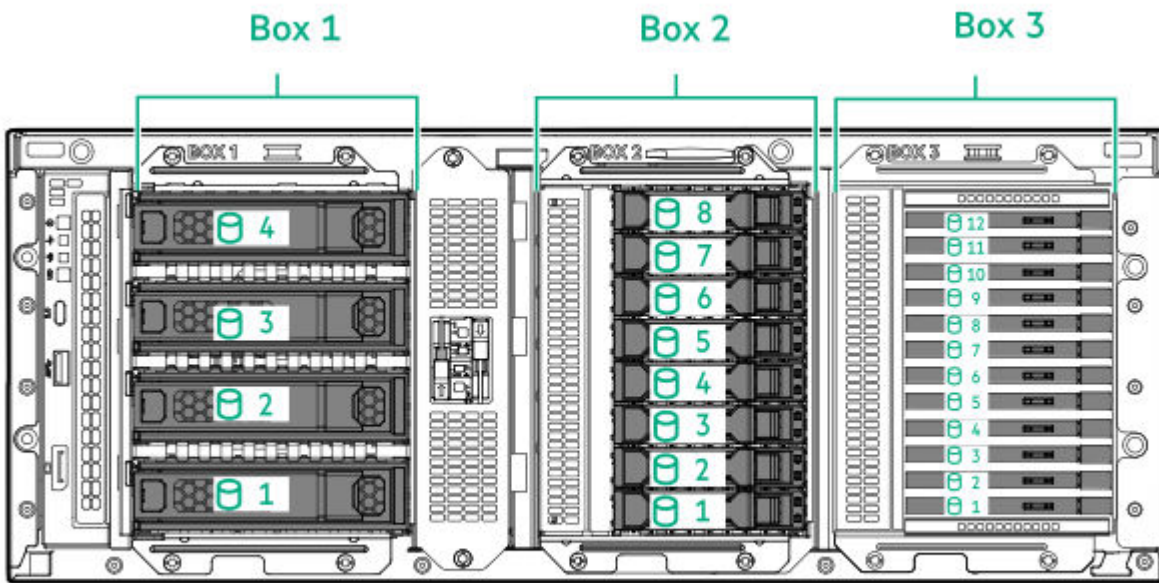

8 SFF + 12 E3.S

Tower orientation

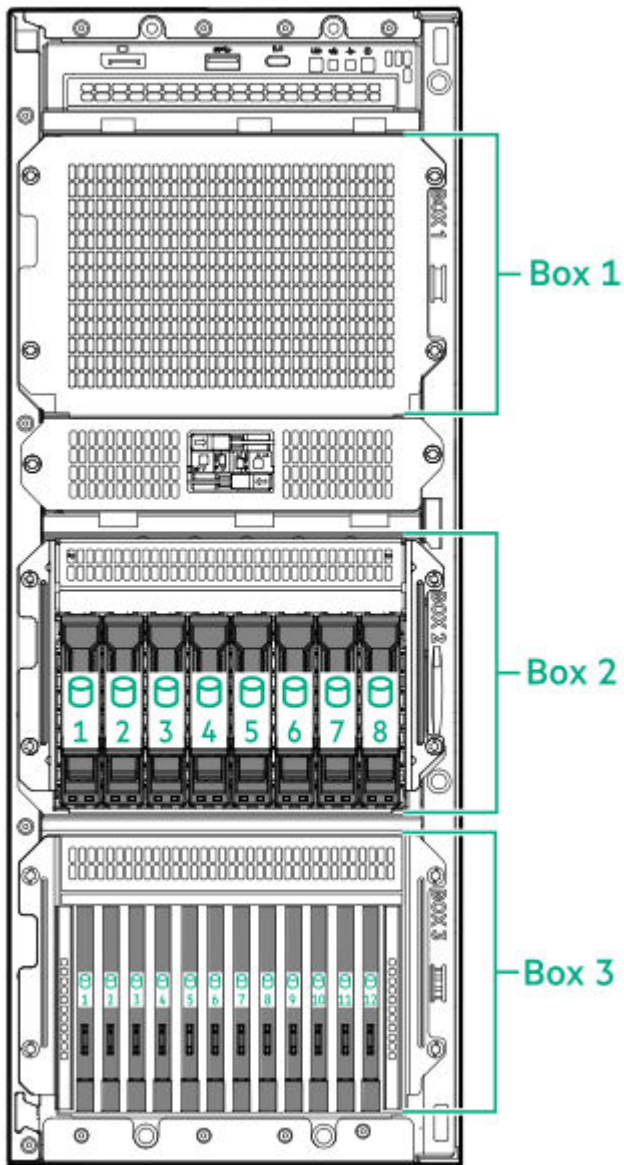

Rack orientation

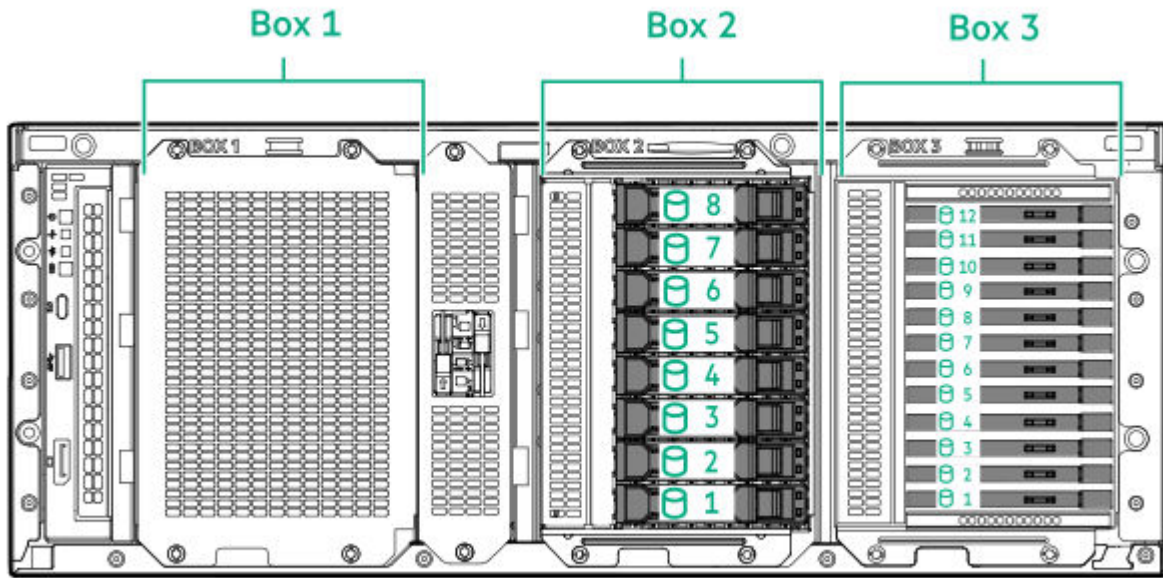

16 SFF + 12 E3.S

Tower orientation

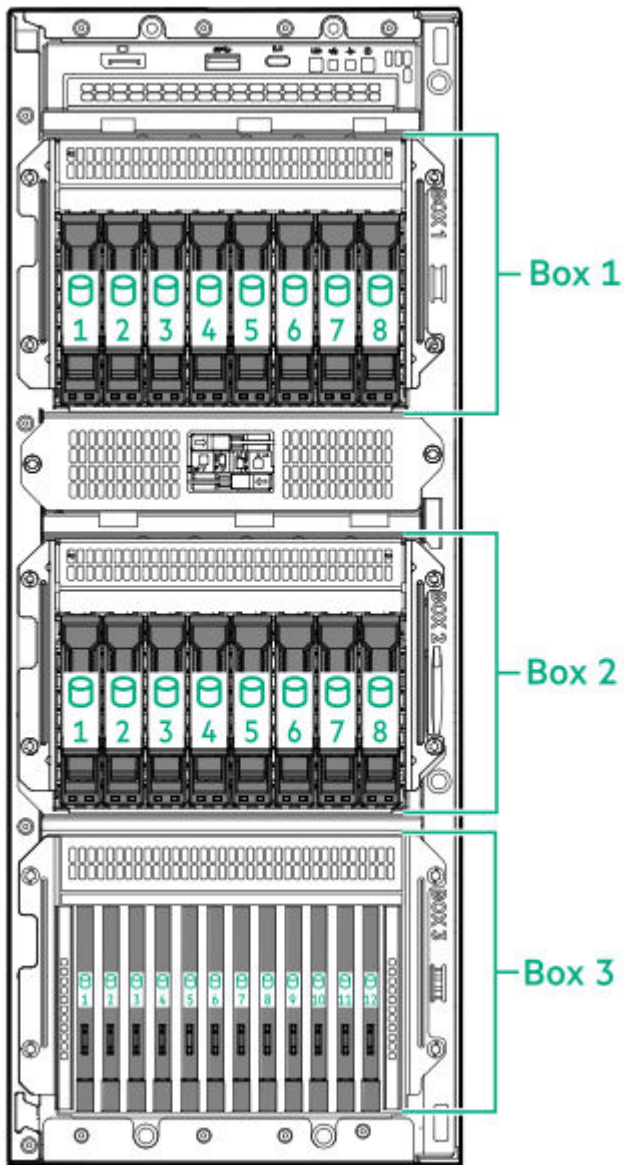

Rack orientation

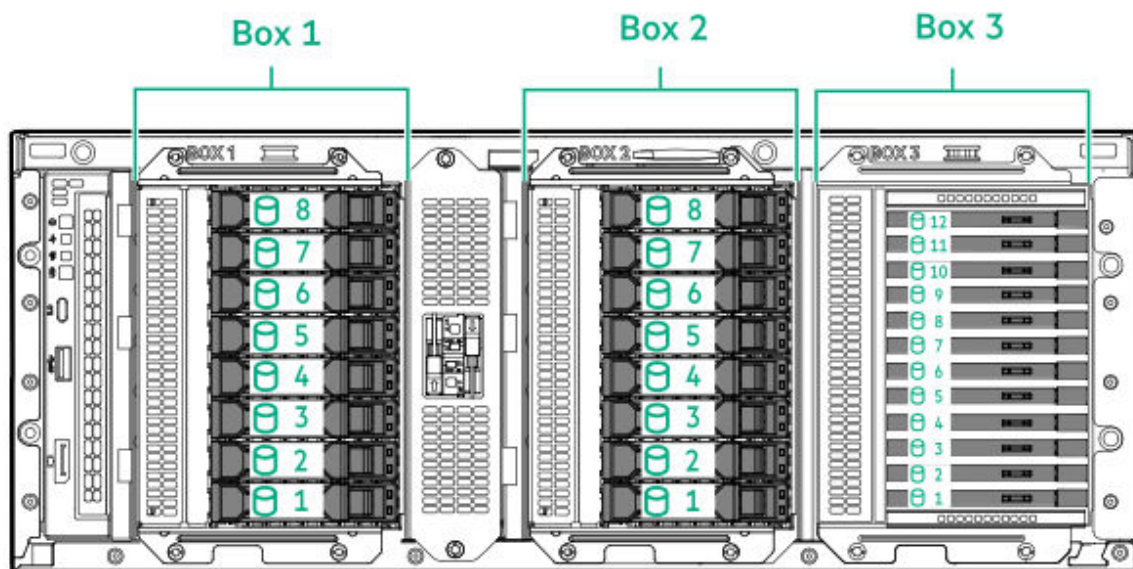

E3.S drive bay numbering

The 4 E3.S 32G x4 NVMe UBM10 EC drive backplane is supported in the E3.S drive box by default in Box 3.

For more information on the drive backplane description, see [Drive backplane naming](#).

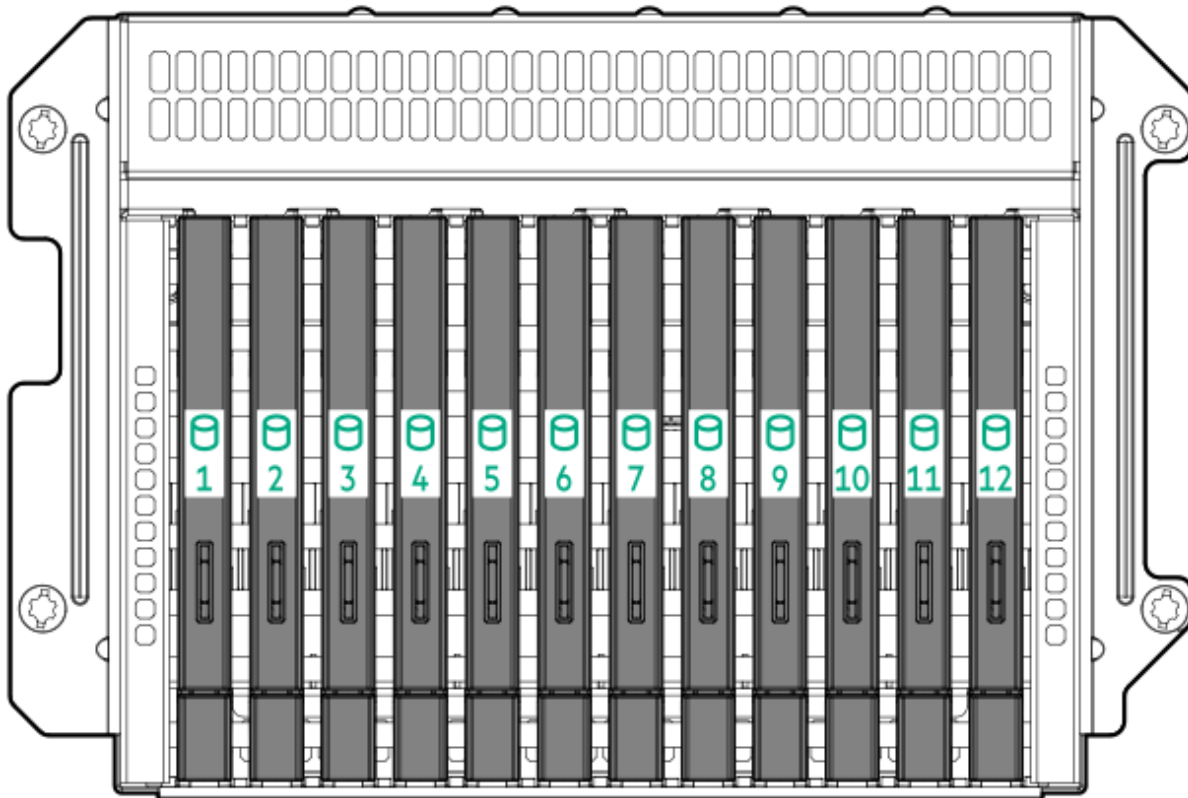

Drive backplane naming

This topic explains the features represented in the drive backplane naming. This naming convention was adopted starting in the HPE Gen11 server release. Your server might not support all the features listed in this topic. For server-specific support information, see the server guides:

- Drive backplane support, see [Drive bay numbering](#).
- Drive backplane cabling, see [Storage cabling](#).

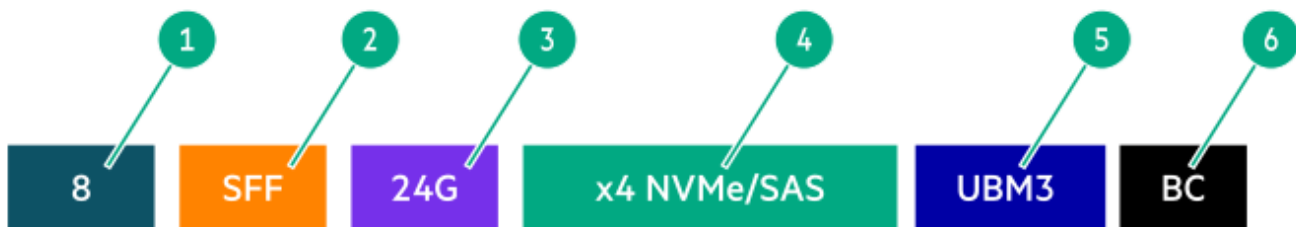

Item	Description	Values
1	Drive bay count	Number of drive bays supported by the backplane.
2	Drive form factor	LFF—Large Form Factor
		SFF—Small Form Factor
		E3S—Enterprise and Datacenter Standard Form Factor (EDSFF E3.S)
3	Maximum link rate per lane (GT/s)	12G
		16G
		24G
		32G
4	Port link width and interface	x1 NVMe/SAS—U.3 NVMe, SAS, or SATA ¹
		x4 NVMe/SAS—U.3 NVMe, SAS, or SATA ²
		x4 NVMe—NVMe ³
		x4 NVMe—E3.S
5	Universal backplane manager (UBM) model	The UBM model defines the UBM firmware used by the backplane. Examples of UBM models: UBM2, UBM3, and etc.
6	Drive carrier type	BC—Basic carrier (SFF)
		LP—Low-profile carrier (LFF)
		EC—E3.S carrier

¹ Tri-mode controller support for x1 U.3 NVMe, SAS, and SATA drives. System board connection supports SATA drives only.

² CPU direct attach or tri-mode controller support for x4 U.3 NVMe, x2 (via a splitter cable) U.3 NVMe, or x1 SAS and SATA drives.

³ CPU direct attach or tri-mode controller support for x4 NVMe drives.

HPE Basic Drive LED definitions

The HPE Basic drive carrier has the following LEDs:

- Amber/blue LED—Managed by the drive backplane in conjunction with the storage controller and is used to indicate drive status.
- Green LED—Managed by the drive itself and indicates the drive activity.

LFF low-profile drive carrier

The LFF low-profile drive carrier supports hot-plug SAS and SATA drives.

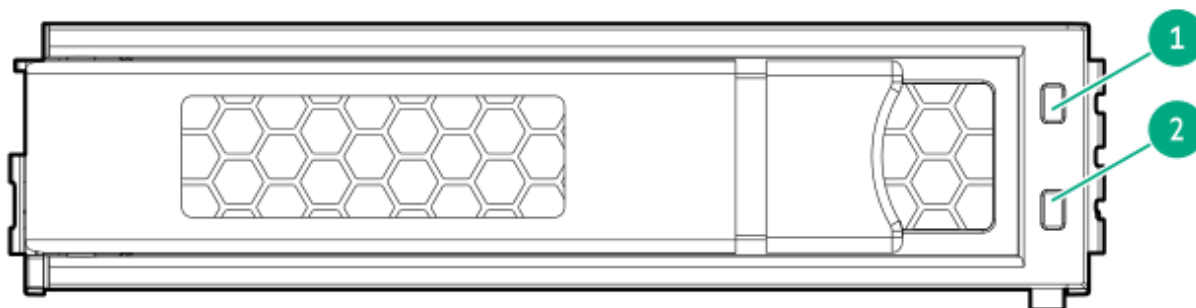

SFF basic drive carrier

The SFF basic drive carrier supports hot-plug SAS, SATA, and U.3 PCIe4 NVMe drives.

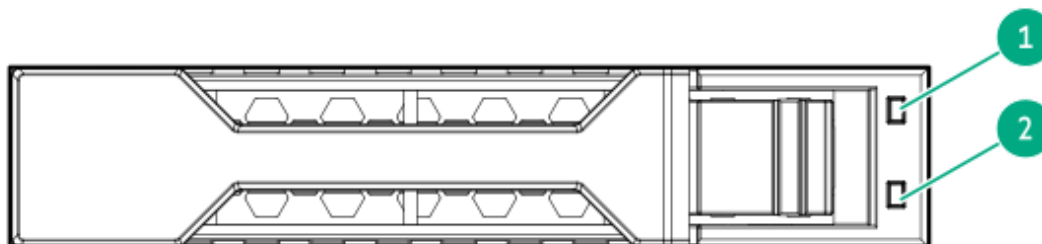

Item	LED	State	Definition
1	Fault/Locate	Solid amber	This drive has failed, is unsupported, or is invalid.
		Solid blue	The drive is operating normally and being identified by a management application.
		Flashing amber/blue (1 flash per second)	The drive has failed, or a predictive failure alert has been received for this drive. The drive has also been identified by a management application.
		Flashing amber (1 flash per second)	A predictive failure alert has been received for this drive. Replace the drive as soon as possible.

Item	LED	State	Definition
		Off	The drive is operating normally and not being identified by a management application.
2	Online/Activity	Solid green	The drive is online and has no activity.
		Flashing green (1 flash per second)	The drive is doing one of the following: <ul style="list-style-type: none"> • Rebuilding or performing a RAID • Performing a stripe size migration • Performing a capacity expansion • Performing a logical drive extension • Erasing • Spare part activation
		Flashing green (4 flashes per second)	The drive is operating normally and has activity.
		Off	The drive is not configured by a RAID controller or is a spare drive.

EDSFF SSD LED definitions

The EDSFF drive carrier has two LEDs:

- Amber/blue LED—Managed by the drive backplane in conjunction with the storage controller and is used to indicate drive status.
- Green LED—Managed by the drive itself and indicates the drive activity.

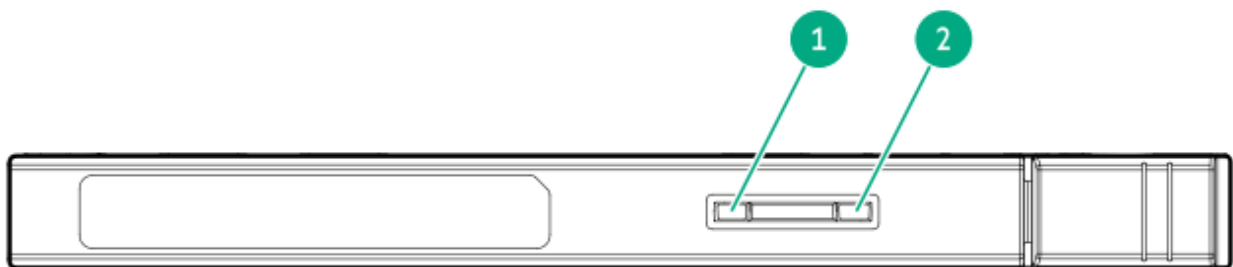

Item	LED	State	Definition
1	Fault/Locate	Solid amber	This drive has failed, is unsupported, or is invalid.
		Solid blue	The drive is operating normally and being identified by a management application.
		Flashing amber/blue (1 flash per second)	The drive has failed, or a predictive failure alert has been received for this drive. The drive has also been identified by a management application.
		Flashing amber (1 flash per second)	A predictive failure alert has been received for this drive. Replace the drive as soon as possible.
		Off	The drive is operating normally and not being identified by a management application.
2	Online/Activity	Solid green	The drive is online and has no activity.
		Flashing green (4 flashes per second)	The drive is operating normally and has activity.
		Off	No power present.

HPE NS204i-u Boot Device V2 components

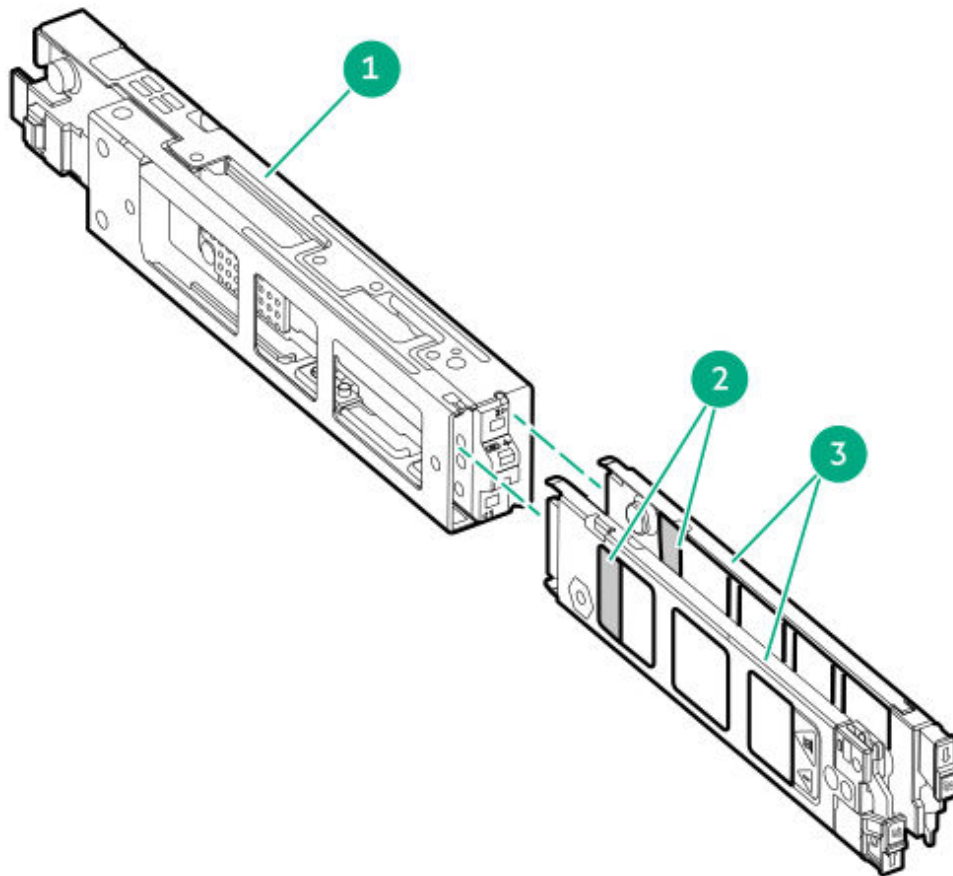

Item	Description
1	Boot device cage
2	M.2 slots
3	Boot device carriers

HPE NS204i-u Boot Device V2 LED definitions

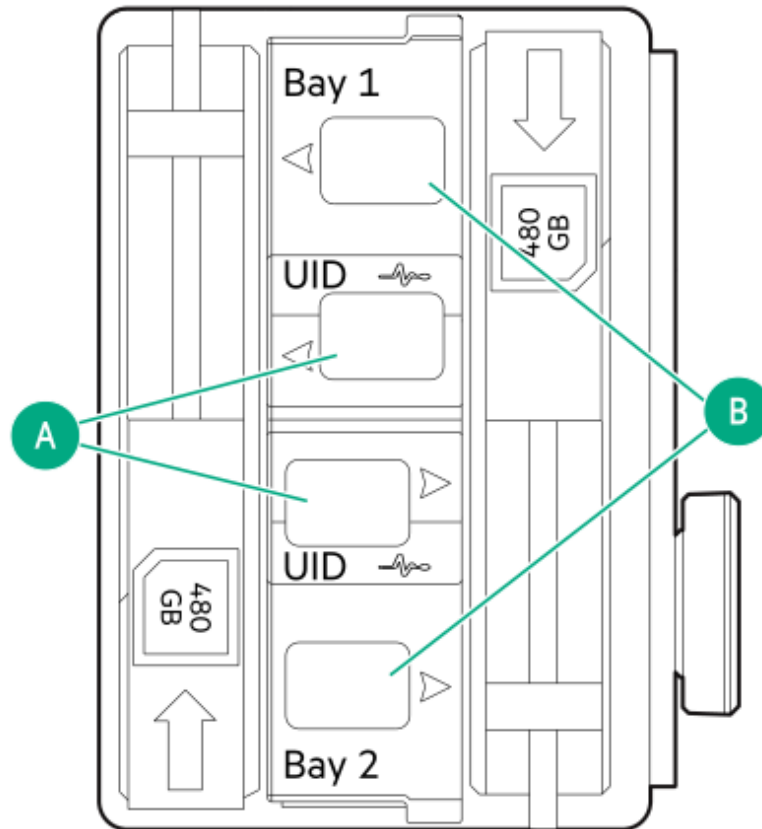

NOTE

The bay number can be found on the SSD carrier handle.

Item	LED	Status	Definition
A	Fault or Locate	Solid amber	Drive has failed, unsupported, or invalid.
		Solid blue	Drive is operating normally.
		Flashing amber or blue (one flash per second)	Drive has failed, or a predictive failure alert is received for the drive.
		Flashing amber (one flash per second)	Drive predictive failure alert is received. Replace the drive as soon as possible.
		Off	Drive is operating normally and is not identified by any application.
B	Online/Activity	Solid green	Drive is online and has no activity.

Item	LED	Status	Definition
		Flashing green (one flash per second)	Drive is doing one of the following: <ul style="list-style-type: none"> Rebuilding or performing a RAID Erasing
		Flashing green (4 flashes per second)	Drive is operating normally and has activity.
		Off	Drive is not configured by a RAID controller.

Riser board components

The PCIe5 4 x8 and PCIe5 2 x16 riser options can be installed in either the primary or the secondary riser location. This server supports mixed PCIe5 4 x8 + 2 x16 risers.

PCIe5 4 x8 riser components

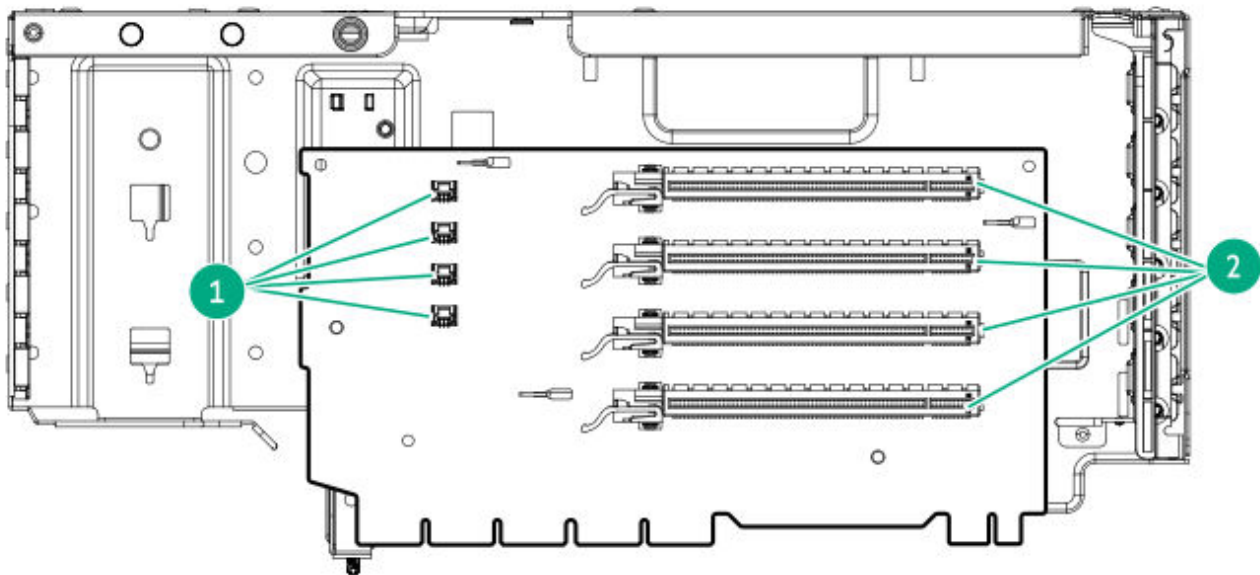

Item	Description
1	Storage controller backup power connectors
2	PCIe5 x16 (8, 4, 1) slots

PCIe 2 x16 riser components

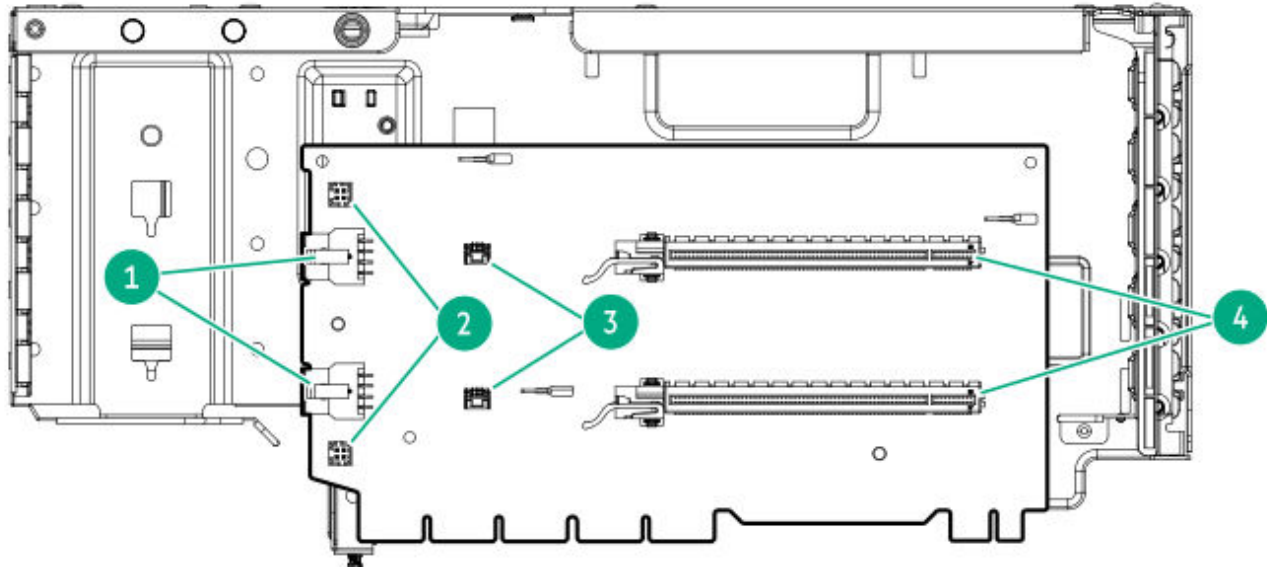

Item	Description
1	GPU auxiliary power connectors
2	GPU sideband connectors
3	Storage controller backup power connectors
4	PCIe x16 (16, 8, 4, 1) slots

Riser slot numbering

- Primary and secondary riser slots are PCIe5 x16 (16, 8, 4, 1) or PCIe5 x16 (8, 4, 1)
- Tertiary riser slots are PCIe5 x16 (8, 4, 1).

All riser slots are rated for a maximum power draw of 75 W each without an auxiliary power cable.

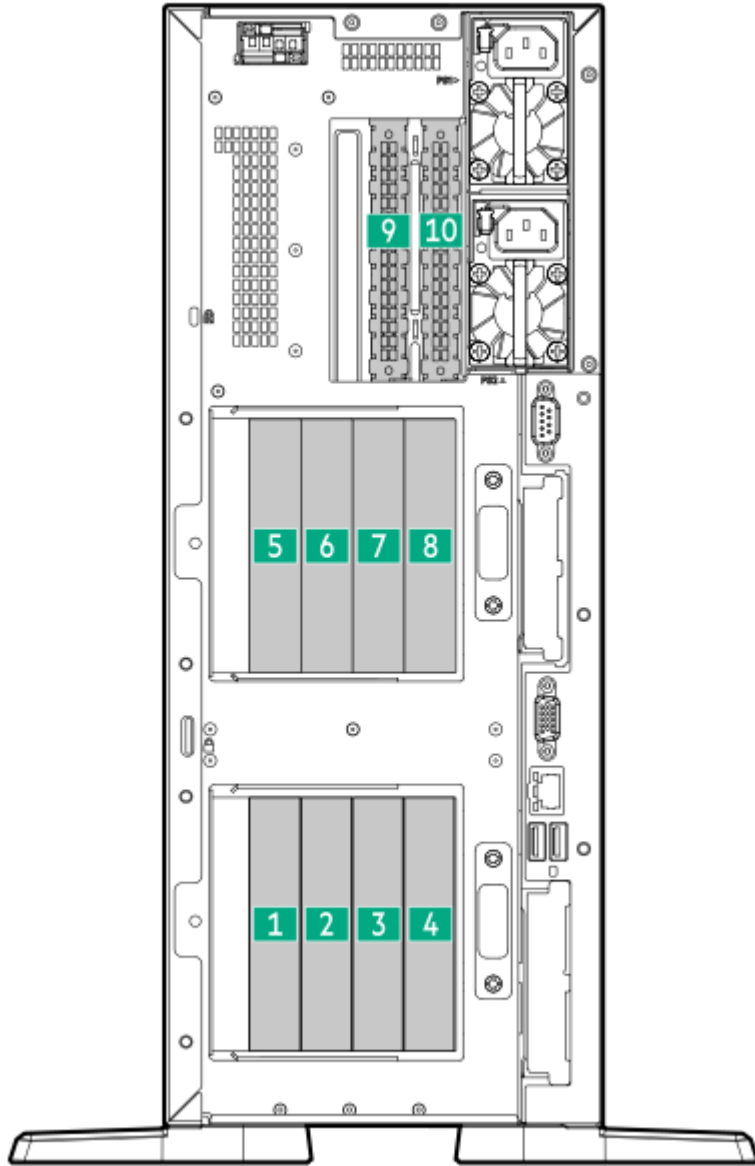

Slot number	Location	Supported form factors
1	Primary riser cage	<ul style="list-style-type: none"> • Full-height, full-length • Full-height, half-length • Half-height, half-length (low-profile)
2		
3		
4		
5	Secondary riser cage	
6		
7		
8		
9		
10		

Slot number	Location	Supported form factors
8 ¹		
9	Tertiary riser cage	Half-height, half-length (low-profile)
10		

¹ This slot on the PCIe5 2 x16 riser board supports double-width GPUs.

Media device screws

There are 12 T-15 Torx screws on the server chassis. These screws are provided as spare screws for installing media devices.

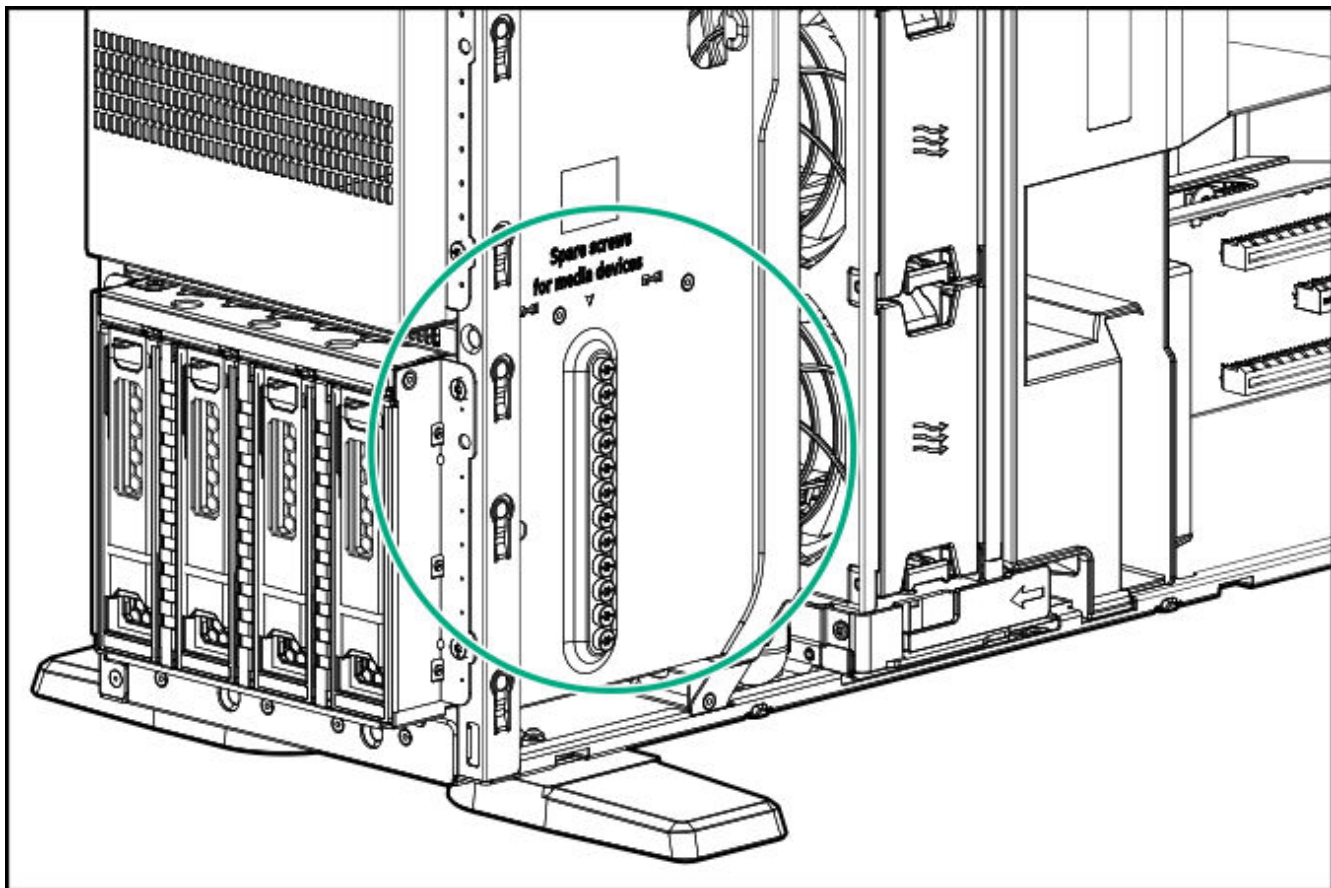

Troubleshooting

Subtopics

[NMI functionality](#)

[Front panel LED power fault codes](#)

[Troubleshooting resources](#)

NMI functionality

An NMI crash dump enables administrators to create crash dump files when a system is not responding to traditional debugging methods.

An analysis of the crash dump log is an essential part of diagnosing reliability problems, such as hanging operating systems, device drivers, and applications. Many crashes freeze a system, and the only available action for administrators is to cycle the system power. Resetting the system erases any information that could support problem analysis, but the NMI feature preserves that information by performing a memory dump before a hard reset.

To force the OS to initiate the NMI handler and generate a crash dump log, the administrator can use the iLO Generate NMI feature.

Front panel LED power fault codes

The following table provides a list of power fault codes, and the subsystems that are affected. Not all power faults are used by all servers.

Subsystem	LED behavior
System board	1 flash
Processor	2 flashes
Memory	3 flashes
Riser board PCIe slots	4 flashes
OCP adapter	5 flashes
Storage controller	6 flashes
System board PCIe slots	7 flashes
Power backplane	8 flashes
Storage backplane	9 flashes
Power supply	10 flashes

Subsystem	LED behavior
PCIe expansion cards installed in riser board	11 flashes
Chassis	12 flashes
GPU card	13 flashes

Troubleshooting resources

If you need help troubleshooting, see the latest articles for your server.

<https://www.hpe.com/info/ml350gen12-ts>

Cabling

This chapter includes cabling guidelines and diagrams for internal component cabling.

Subtopics

[Cabling guidelines](#)

[Cabling diagrams](#)

[Internal cabling management](#)

[Storage cabling](#)

[Media device cabling](#)

[HPE NS204i-u Boot Device V2 cabling](#)

[GPU auxiliary power cabling](#)

[Fan cabling](#)

[OCP bandwidth enablement cabling](#)

[Tertiary riser signal cabling](#)

[Serial port cabling](#)

[Chassis intrusion detection switch cabling](#)

[Front I/O cabling](#)

Cabling guidelines

Observe the following:



NOTE

The colors in the cabling diagrams are for illustration purposes only.



CAUTION

To avoid damaging connectors, avoid repeated installation and removal of cables. Excessive handling can shorten the lifespan of the cable.

- For cable option kits, see the product QuickSpecs.
- For cable spare part numbers, see the Illustrated parts catalog in the maintenance and service guide.
- Some diagrams show alphabetical callouts such as A, B, C, etc. These callouts correspond to labels near the connectors on the cable.
- Some cables have more than one connector, such as a Y-cable, but not all connectors are used.
- Observe all guidelines when working with server cables.

Before connecting cables

- Note the port labels on the PCA components. Not all these components are used by all servers:
 - System board ports
 - Drive and power supply backplane ports
 - Expansion board ports (controllers, retimers, adapters, expanders, risers, and similar boards)
- Note the label near each cable connector. This label indicates the destination port for the cable connector.
- Some data cables are prebent. Do not unbend or manipulate the cables.
- To prevent mechanical damage or depositing oil that is present on your hands, and other contamination, do not touch the ends of the connectors.

When connecting cables

- Before connecting a cable to a port, lay the cable in place to verify the length of the cable.
- Use the internal cable management features to properly route and secure the cables.

- Route cables so that they do not contact or rest on cooling components, including heatsinks. Ensure that cable routing does not obstruct airflow to or from heatsinks or ventilation openings
- When routing cables, be sure that the cables are not in a position where they can be pinched or crimped.
- Avoid tight bend radii to prevent damaging the internal wires of a power cord or a server cable. Never bend power cords and server cables tight enough to cause a crease in the sheathing.
- Make sure that the excess length of cables is properly secured to avoid excess bends, interference issues, and airflow restriction.
- Before installing a new component or closing up the server, make sure that all cables are in their appropriate routing position. This cable check prevents component damage and potential signal interference.

When disconnecting cables

- Grip the body of the cable connector. Do not pull on the cable itself because this action can damage the internal wires of the cable or the pins on the port.

- If a cable does not disconnect easily, check for any release latch that must be pressed to disconnect the cable.

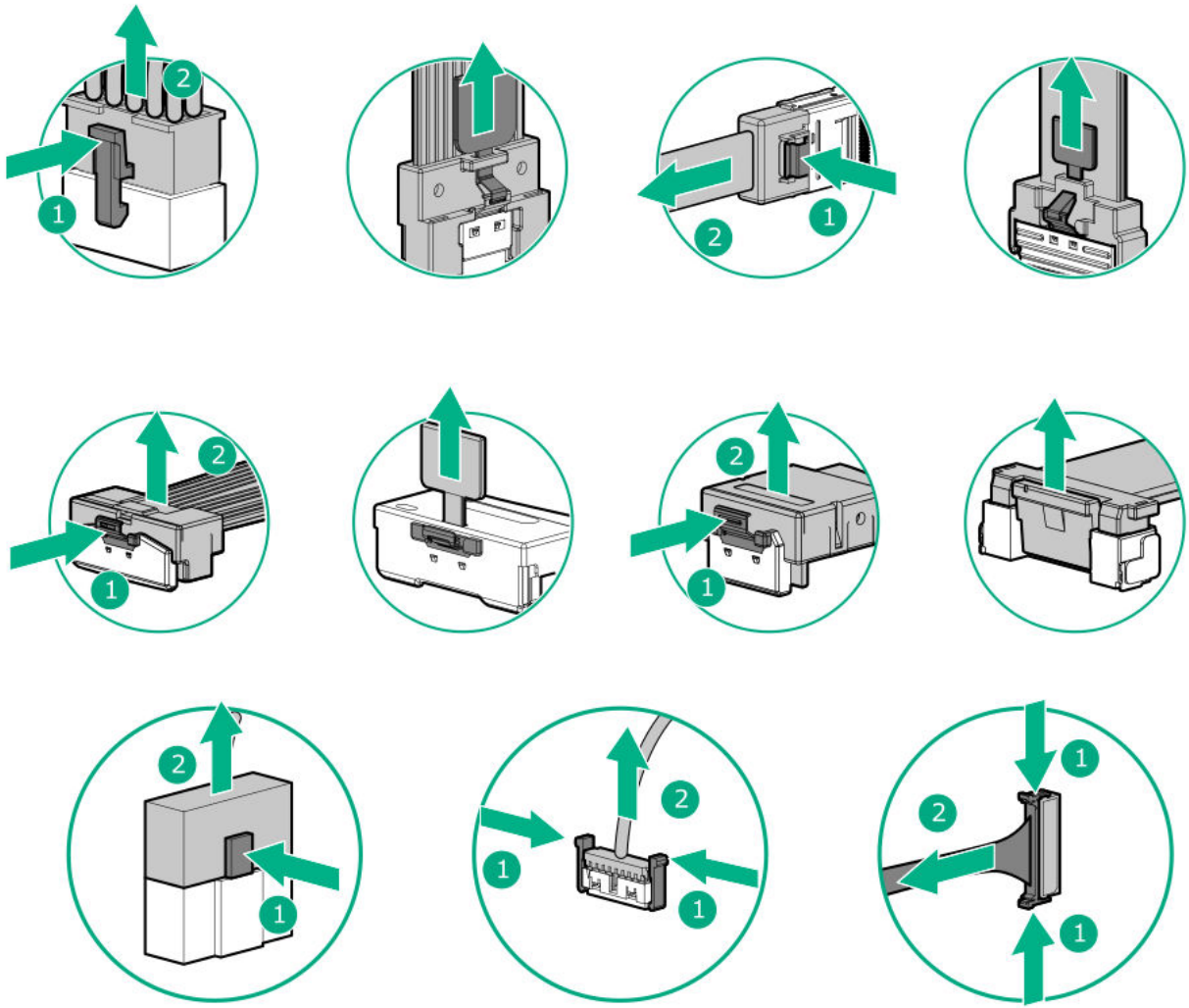

- Remove cables that are no longer being used. Retaining them inside the server can restrict airflow. If you intend to use the removed cables later, label and store them for future use.

Cabling diagrams

Observe the following:

- Before cabling components, see the [Cabling guidelines](#).
- Use the cable part number or search feature to find your diagram.

Component cabling	Cable part number
Drive power cabling	—
LFF/SFF drive power cabling	P75906-001
E3.S drive power cabling	P75277-001
SFF storage controller cabling	—
8/16 SFF drive: Onboard NVMe cabling	P75564-001
24 SFF drive: Direct attached cabling	P75563-001
8/16 SFF SAS/ NVMe x1 drive controller cabling: Type-o controller in Slot 14 OCP A	P45304-001
24 SFF SAS/ NVMe x1 drive controller cabling: Type-p controller in the primary riser	<ul style="list-style-type: none"> • P45296-001 • P45297-001
8 SFF NVMe x4 drive controller cabling in Box 3: MR932i-p in the primary riser	P76443-001
24 SFF NVMe x2 drive controller cabling: MR932i-p in the primary and secondary riser	P78631-001
LFF storage controller cabling	—
4 LFF SAS/SATA drive controller cabling: Type-o controller in Slot 14 OCP A	P49936-001
8/12 LFF SAS/SATA drive controller cabling: Type-o controller in Slot 14 OCP A	<ul style="list-style-type: none"> • P45306-001 • P49936-001
4 LFF SAS/SATA drive controller cabling: Type-p controller in the primary riser	P45300-001
8/12 LFF SAS/SATA drive controller cabling: Type-p controller in the primary riser	<ul style="list-style-type: none"> • P45301-001 • P45300-001
E3.S storage controller cabling	—
12 E3.S drive: Onboard NVMe cabling	P75568-001
12 E3.S drive controller cabling in Box 3: MR932i-p controller in the primary riser	P75570-001
Mixed drive storage controller cabling	—
4 LFF + 16 SFF drive controller cabling	<ul style="list-style-type: none"> • P45296-001

Component cabling	Cable part number
	<ul style="list-style-type: none"> • P49936-001
Energy pack cabling	873905-001
Media device cabling	—
LTO tape drive cabling	Type-o controller: <ul style="list-style-type: none"> • P45303-001 • P49007-001 Type-p controller: <ul style="list-style-type: none"> • P45303-001 • P49006-001
Optical drive cabling	P73776-002
HPE NS204i-u Boot Device V2 cabling	<ul style="list-style-type: none"> • P48956-001 • P74730-001 • P72024-001 • P54089-001
GPU auxiliary power cabling	P58422-001
Fan cabling	—
Internal fans 1-8	<ul style="list-style-type: none"> • P53695-001 • P53694-001
External fans 9-10	P45291-001
OCP bandwidth cabling	—
Slot 14 OCP A PCIe x16 configuration	P74890-001
Slot 15 OCP B PCIe x8 configuration (Single-process or configuration)	P74889-001
Slot 15 OCP B PCIe x16 configuration (Dual-process or configuration)	P74891-001
Miscellaneous cabling	—
Tertiary riser signal cabling	P79969-001
Serial port cabling	P45623-001
Chassis intrusion detection switch cabling	P47751-001

Component cabling

Cable part number

Front I/O cabling

- [P71909-001](#)
- [P75279-001](#)

Internal cabling management

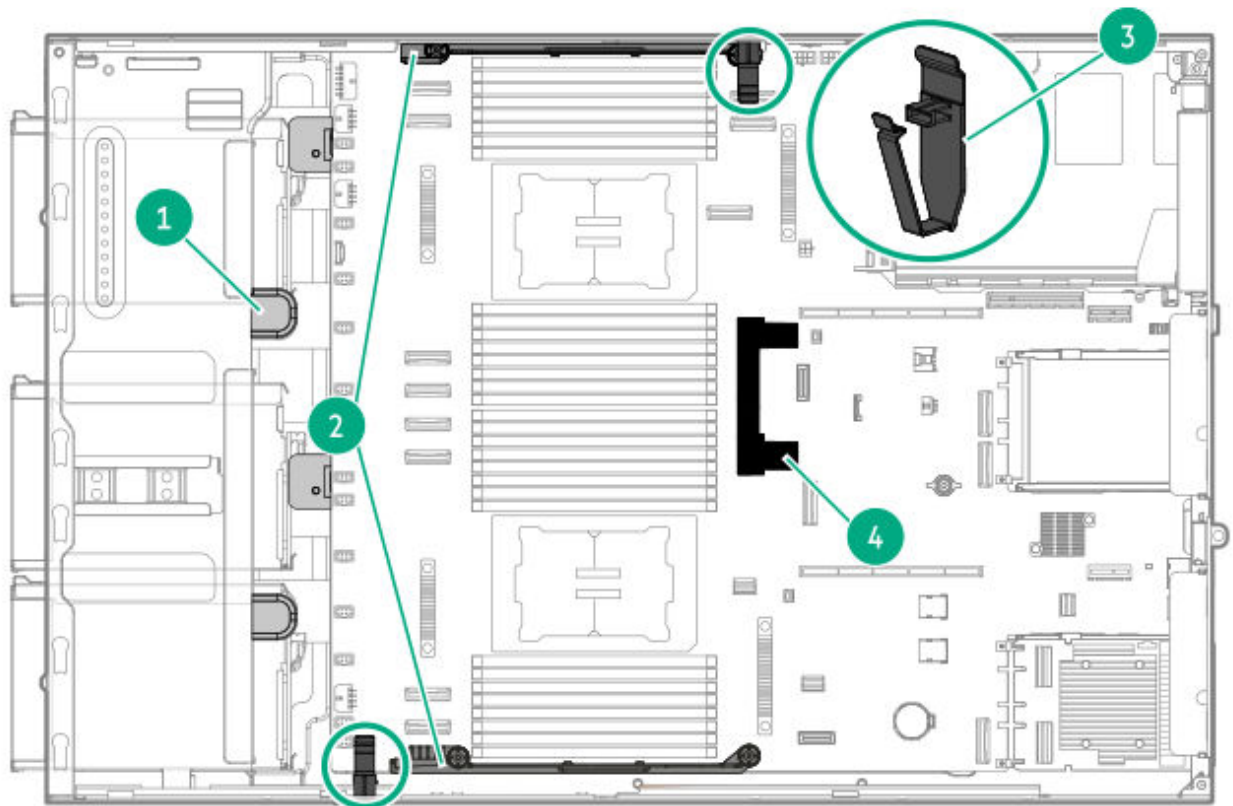

Item	Description
1	Metal tabs
2	DIMM guards
3	Cable clamps
4	System board handle

Storage cabling

Subtopics

Drive power cabling

Storage controller cabling

Energy pack cabling

Drive power cabling

Drive power cables are either preinstalled in the server or structured under the relevant storage controller cable option kit.

LFF/SFF drive power cabling

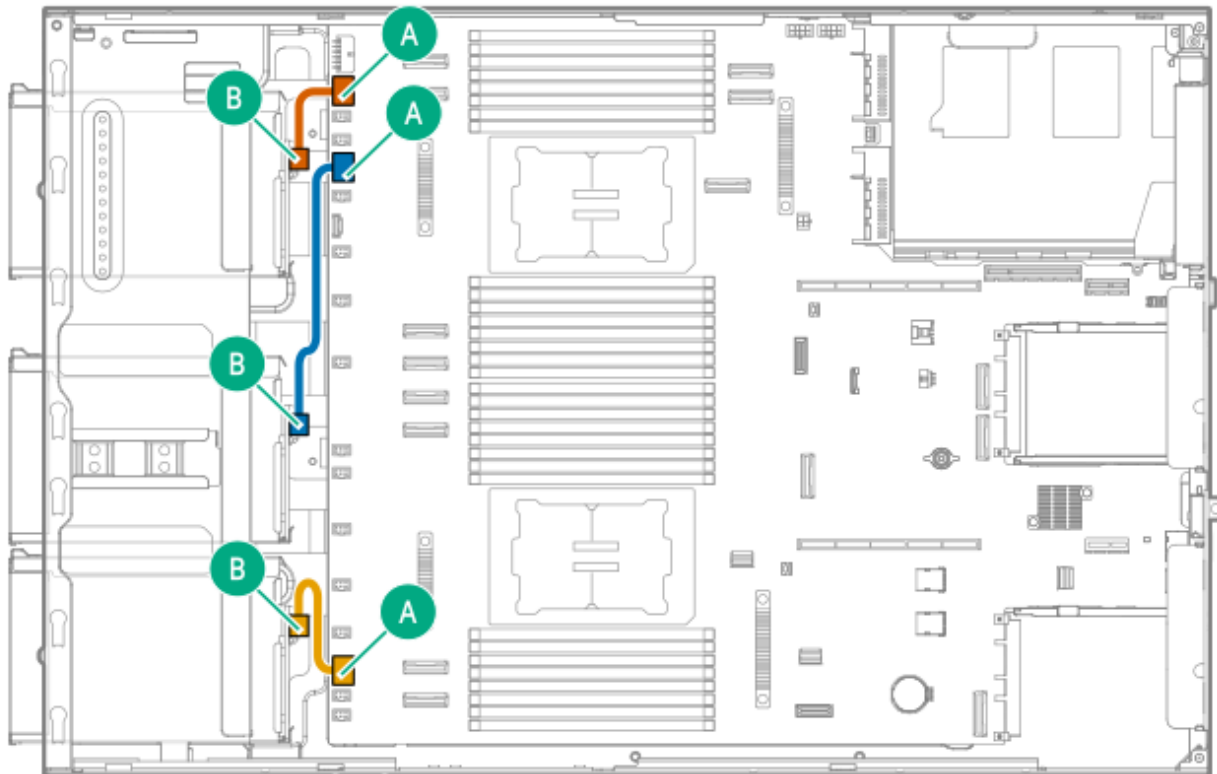

Cable part number	Color	From	To
P75906-001	Orange	Box 1 power connector	Drive box 1 power connector
	Blue	Box 2 power connector	Drive box 2 power connector
	Gold	Box 3 power connector	Drive box 3 power connector

E3.S drive power cabling

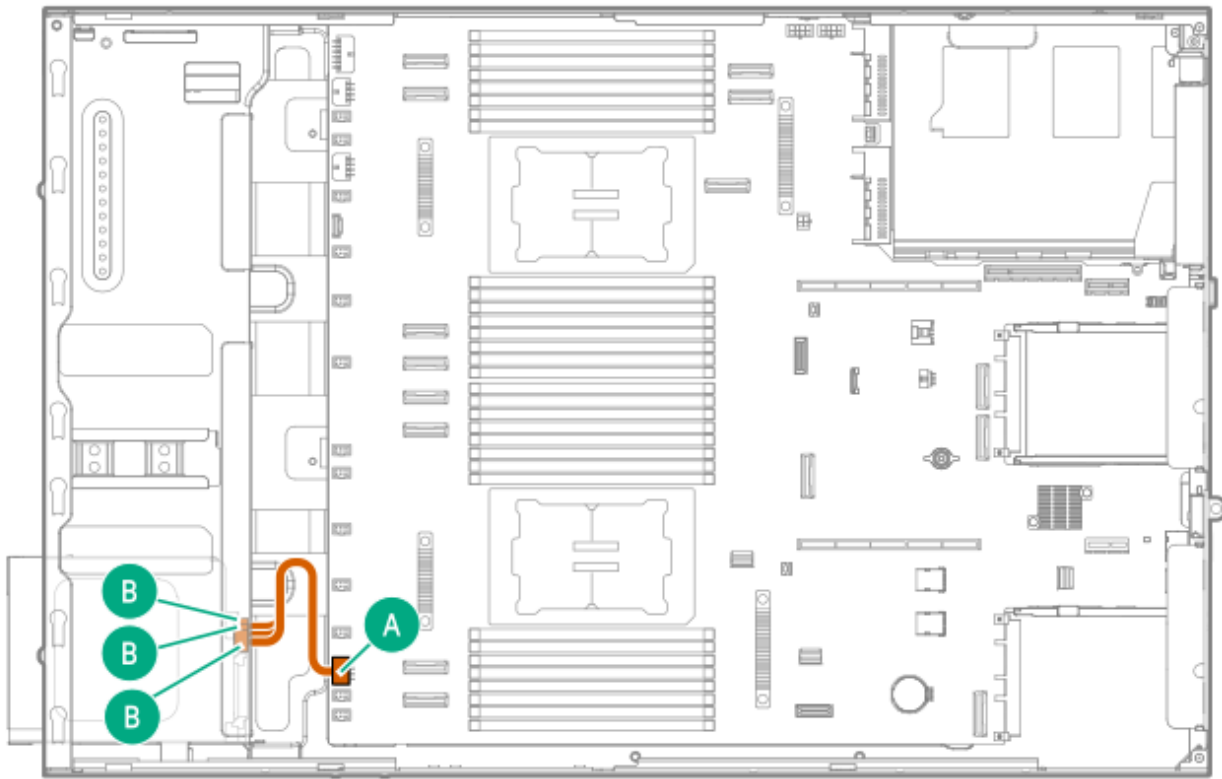

Cable part number	Color	From	To
P75277-001	Orange	Box 3 power connector	Drive box 3 power connector

Storage controller cabling

Subtopics

[SFF drive controller cabling](#)

[LFF drive controller cabling](#)

[E3.S drive controller cabling](#)

[Mixed drive controller cabling](#)

[Storage controller backup power cabling](#)

SFF drive controller cabling

8/16 SFF drive: Onboard NVMe cabling

- Box 2

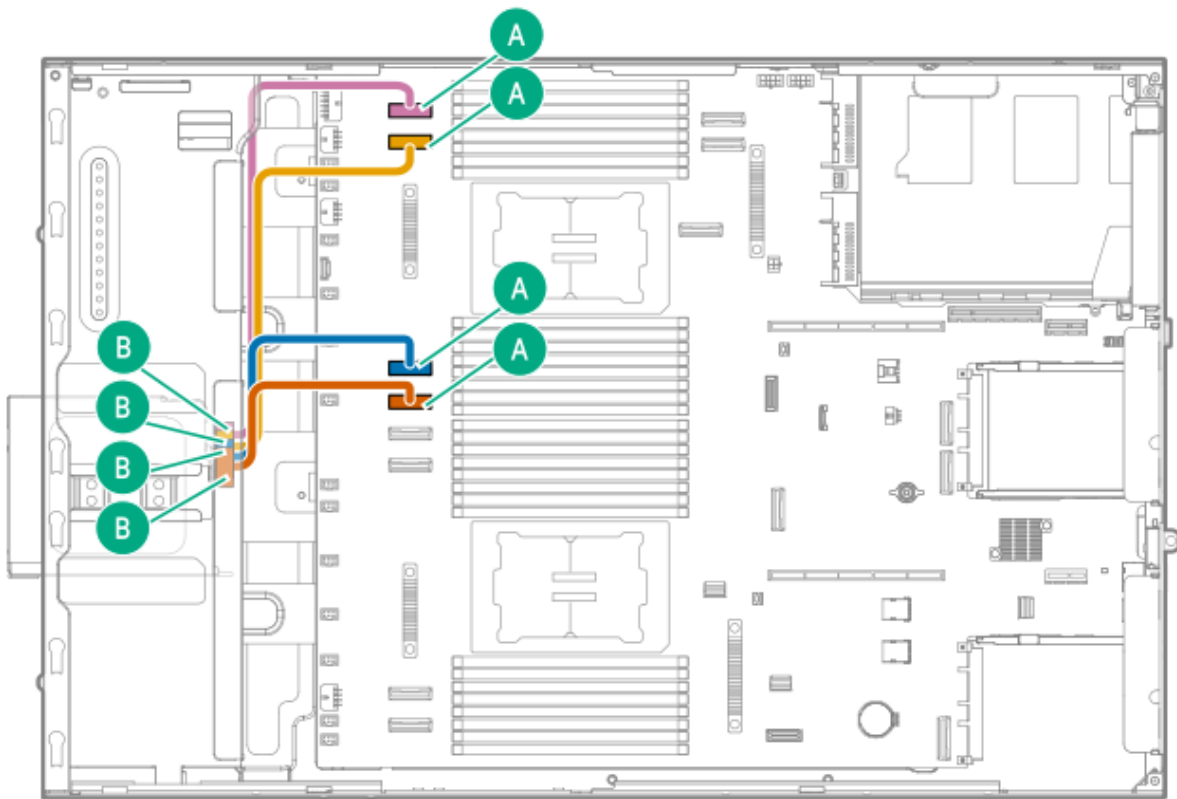

Cable part number	Color	From	To
P75564-001	Orange	Port 4	MCIO port 5

Cable part number	Color	From	To
	Blue	Port 3	MCIO port 6
	Gold	Port 2	MCIO port 7
	Pink	Port 1	MCIO port 8

- Box 3

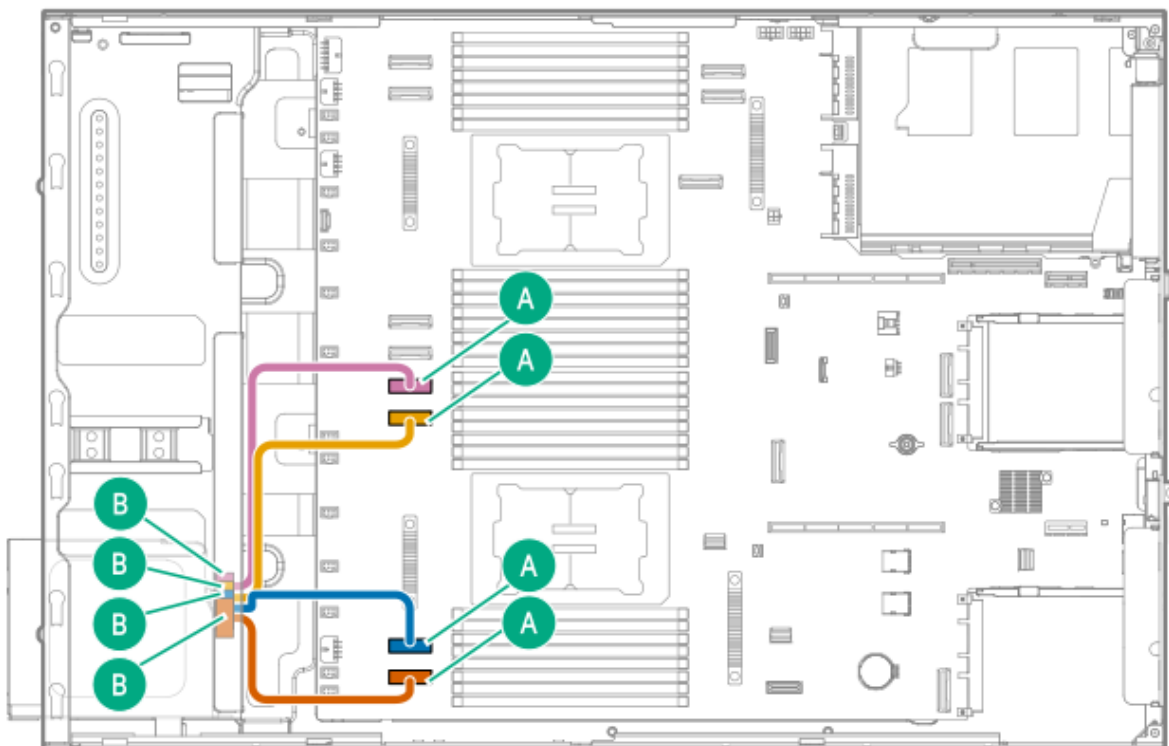

Cable part number	Color	From	To
P75564-001	Orange	Port 4	MCIO port 1
	Blue	Port 3	MCIO port 2
	Yellow	Port 2	MCIO port 3
	Gold	Port 1	MCIO port 4

24 SFF drive: Direct attached cabling

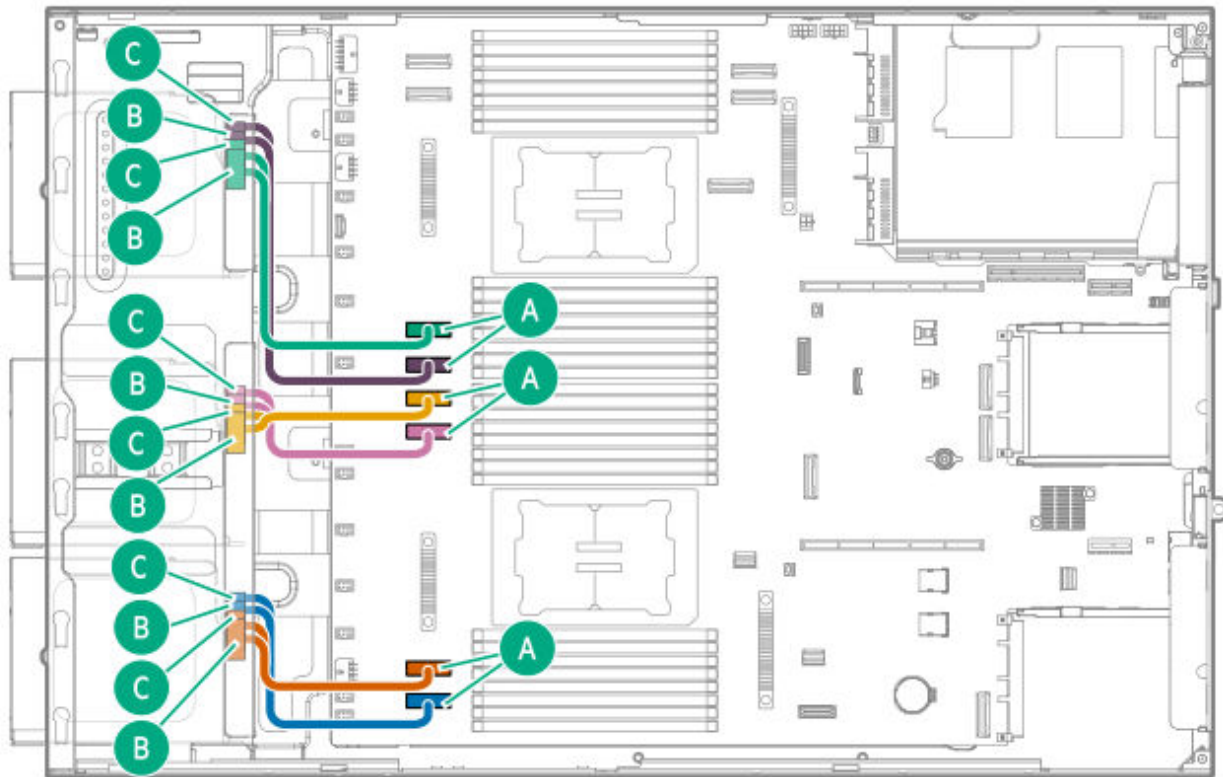

Cable part number	Color	From	To
P75563-001	Orange	Box 3 port 1 (B) and 2 (C)	MCIO port 1
	Blue	Box 3 port 3 (B) and 4 (C)	MCIO port 2
	Gold	Box 2 port 1 (B) and 2 (C)	MCIO port 3
	Pink	Box 2 port 3 (B) and 4 (C)	MCIO port 4
	Green	Box 1 port 1 (B) and 2 (C)	MCIO port 5
	Purple	Box 1 port 3 (B) and 4 (C)	MCIO port 6

8/16 SFF SAS/ NVMe x1 drive controller cabling: Type-o controller in Slot 14 OCP A

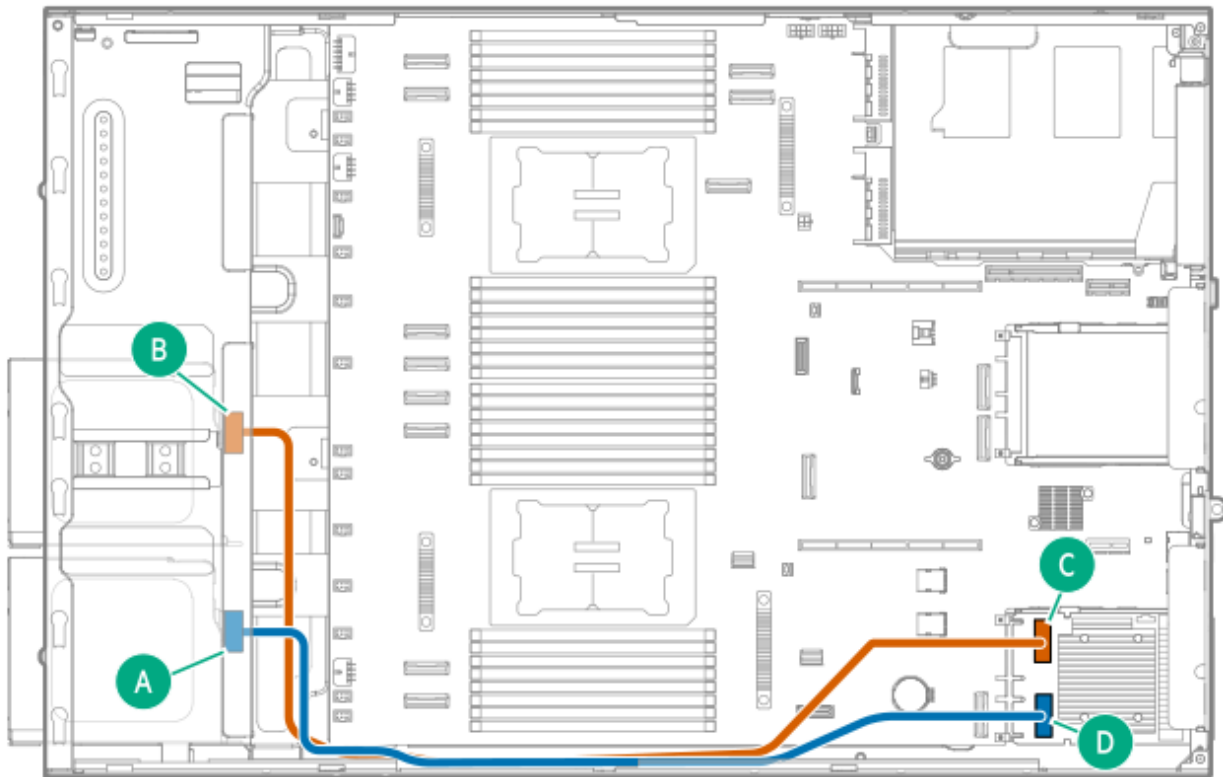

Cable part number	Color	From	To
P45304-001	Orange	Box 2 port 1	Type-o controller port 2
	Blue	Box 3 port 1	Type-o controller port 1

24 SFF SAS/ NVMe x1 drive controller cabling: Type-p controller in the primary riser

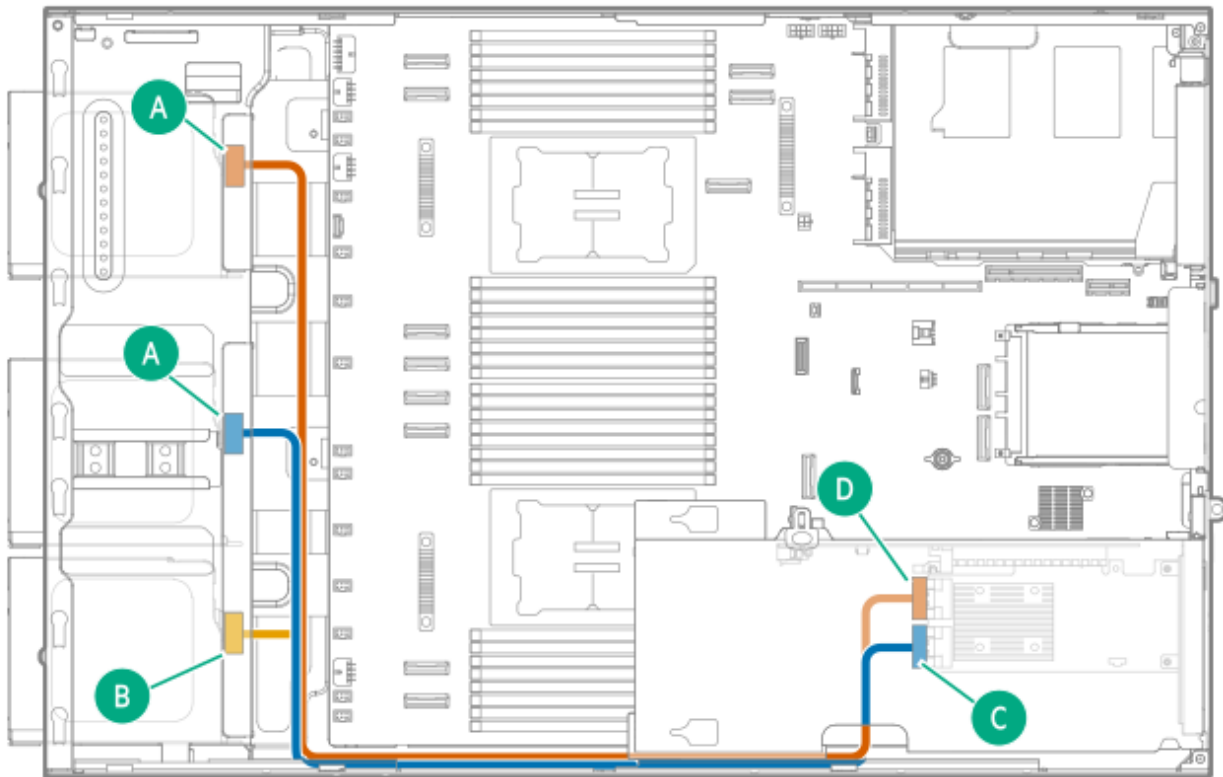

Cable part number	Color	From	To
P45296-001	Orange	Box 1 port 1	Type-p controller port 2
P45297-001	Blue	Box 2 port 1	Type-p controller port 1
	Gold	Box 3 port 1	Type-p controller port 2

8 SFF NVMe x4 drive controller cabling in Box 3: MR932i-p in the primary riser

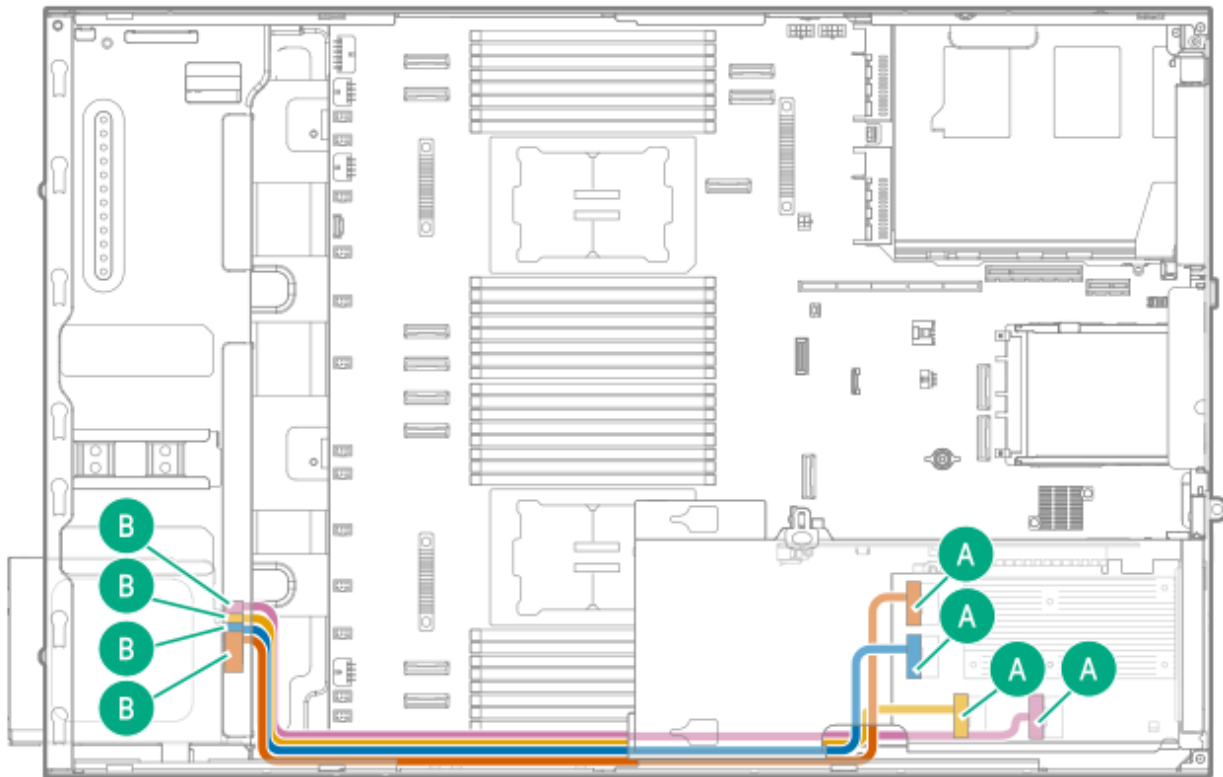

Cable part number	Color	From	To
P76443-001	Orange	Port 2	Port 2
	Blue	Port 1	Port 1
	Gold	Port 4	Port 4
	Pink	Port 3	Port 3

24 SFF NVMe x2 drive controller cabling: MR932i-p in the primary and secondary riser

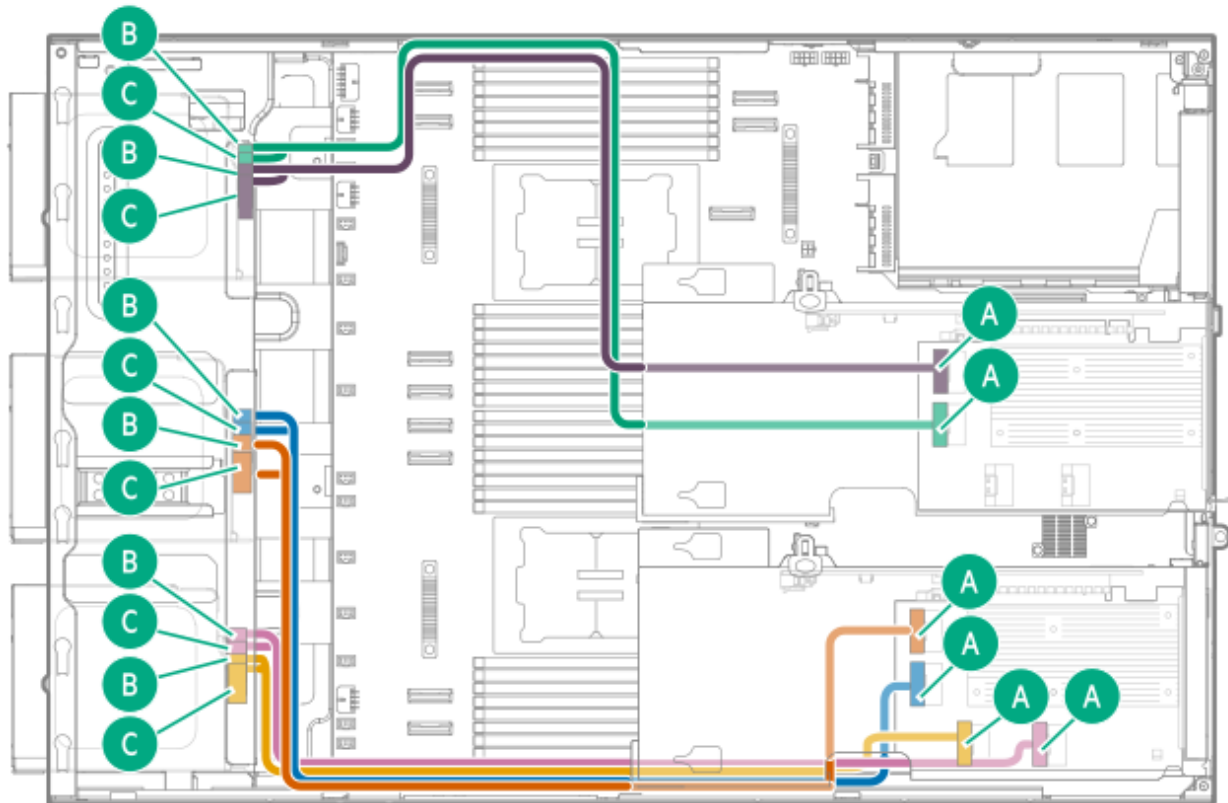

Cable part number	Color	From	To
P78631-001	Orange	Box 2 port 3 (B) and port 4 (C)	Type-p controller in the primary riser port 2
	Blue	Box 2 port 1 (B) and port 2 (C)	Type-p controller in the primary riser port 1
	Gold	Box 3 port 3 (B) and port 4 (C)	Type-p controller in the primary riser port 4
	Pink	Box 3 port 1 (B) and port 2 (C)	Type-p controller in the primary riser port 3
	Green	Box 1 port 1 (B) and port 2 (C)	Type-p controller in the secondary riser port 1
	Purple	Box 1 port 3 (B) and port 4 (C)	Type-p controller in the secondary riser port 2

LFF drive controller cabling

4 LFF SAS/SATA drive controller cabling: Type-o controller in Slot 14 OCP A

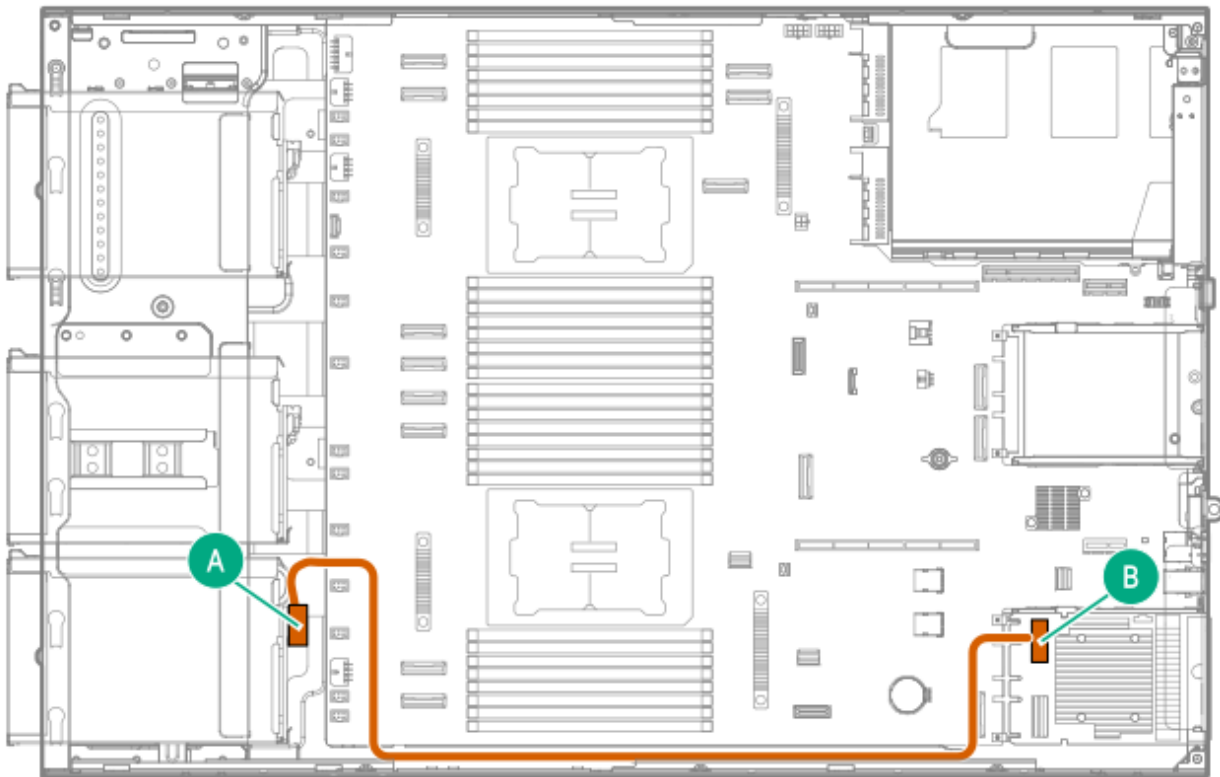

Cable part number	Color	From	To
P49936-001	Orange	Box 3 port 1	Type-o controller port 2

8/12 LFF SAS/SATA drive controller cabling: Type-o controller in Slot 14 OCP A



Cable part number	Color	From	To
P45306-001	Orange	Box 1 port 1 and Box 2 port 1	Type-o controller port 2
P49936-001	Blue	Box 3 port 1	Type-o controller port 1

4 LFF SAS/SATA drive controller cabling: Type-p controller in the primary riser



Cable part number	Color	From	To
P45300-001	Orange	Box 3 port 1	Type-p controller port 2

8/12 LFF SAS/SATA drive controller cabling: Type-p controller in the primary riser

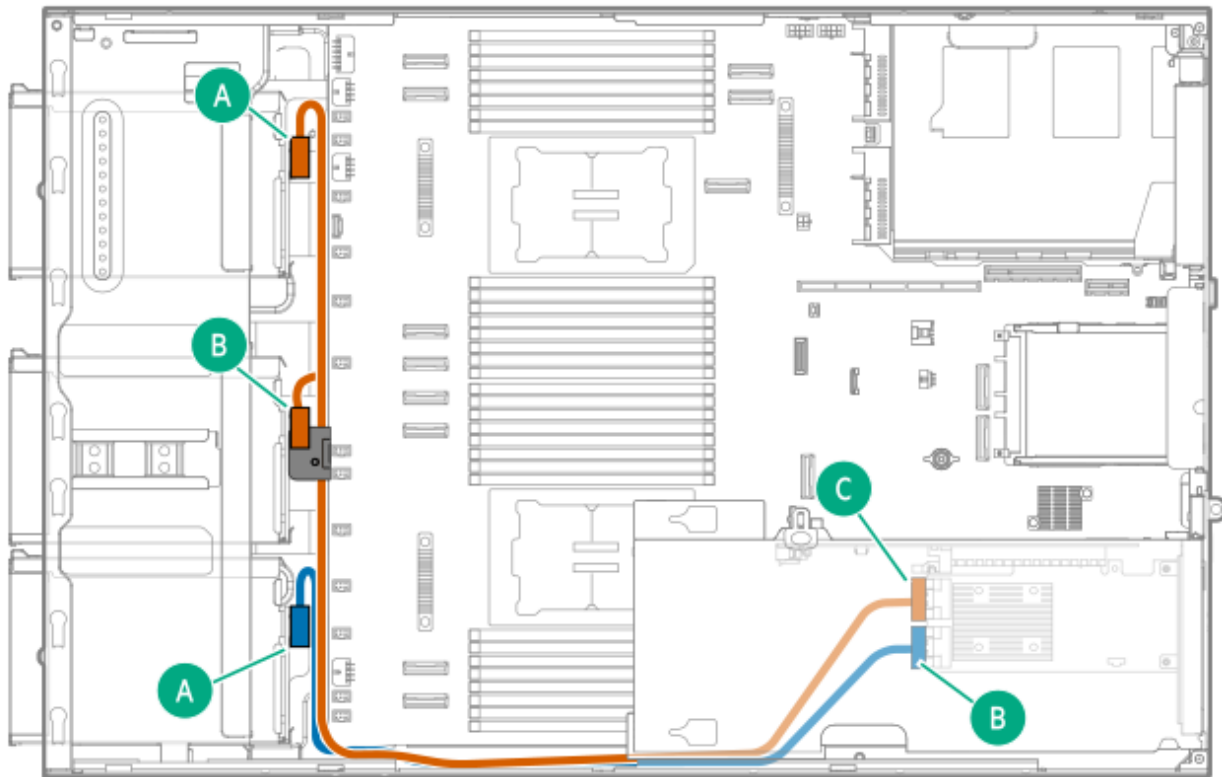

Cable part number	Color	From	To
P45301-001	Orange	Box 1 port 1 and Box 2 port 1	Type-p controller port 2
P45300-001	Blue	Box 3 port 1	Type-p controller port 1

E3.S drive controller cabling

12 E3.S drive: Onboard NVMe cabling

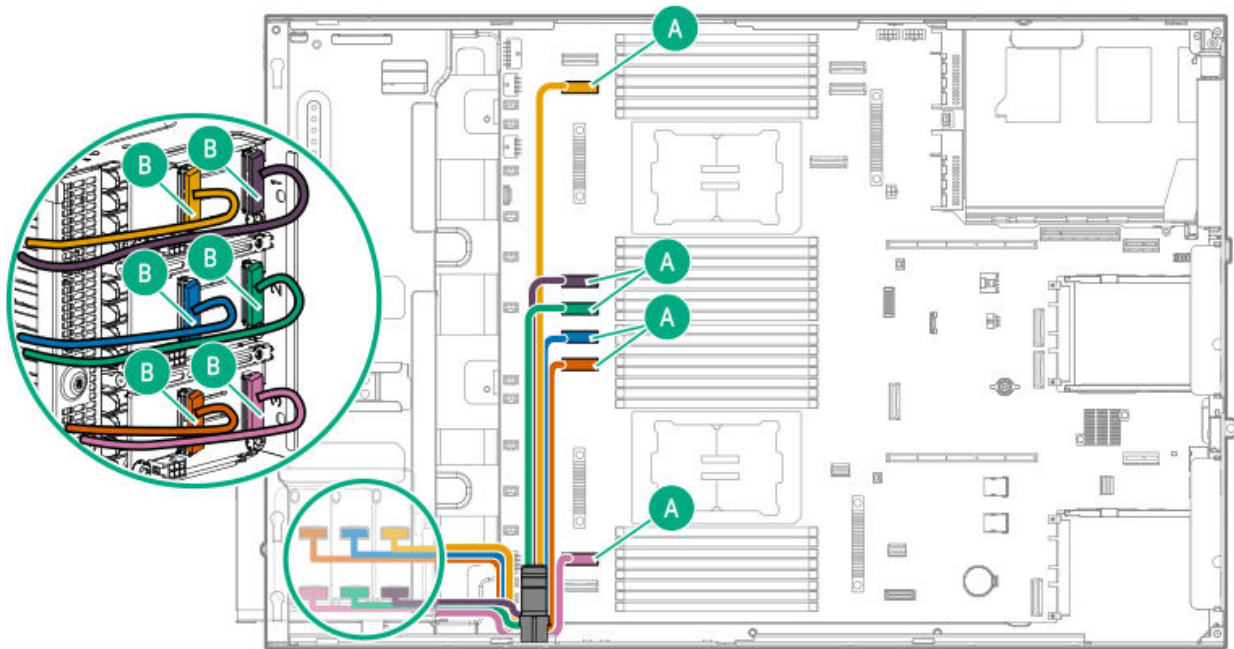

Cable part number	Color	From	To
P75568-001	Orange	Backplane 3 port 2	MCI0 port 3
	Blue	Backplane 2 port 2	MCI0 port 4
	Gold	Backplane 1 port 2	MCI0 port 7
	Pink	Backplane 3 port 1	MCI0 port 2
	Green	Backplane 2 port 1	MCI0 port 5
	Purple	Backplane 1 port 1	MCI0 port 6

12 E3.S drive controller cabling in Box 3: MR932i-p controller in the primary riser

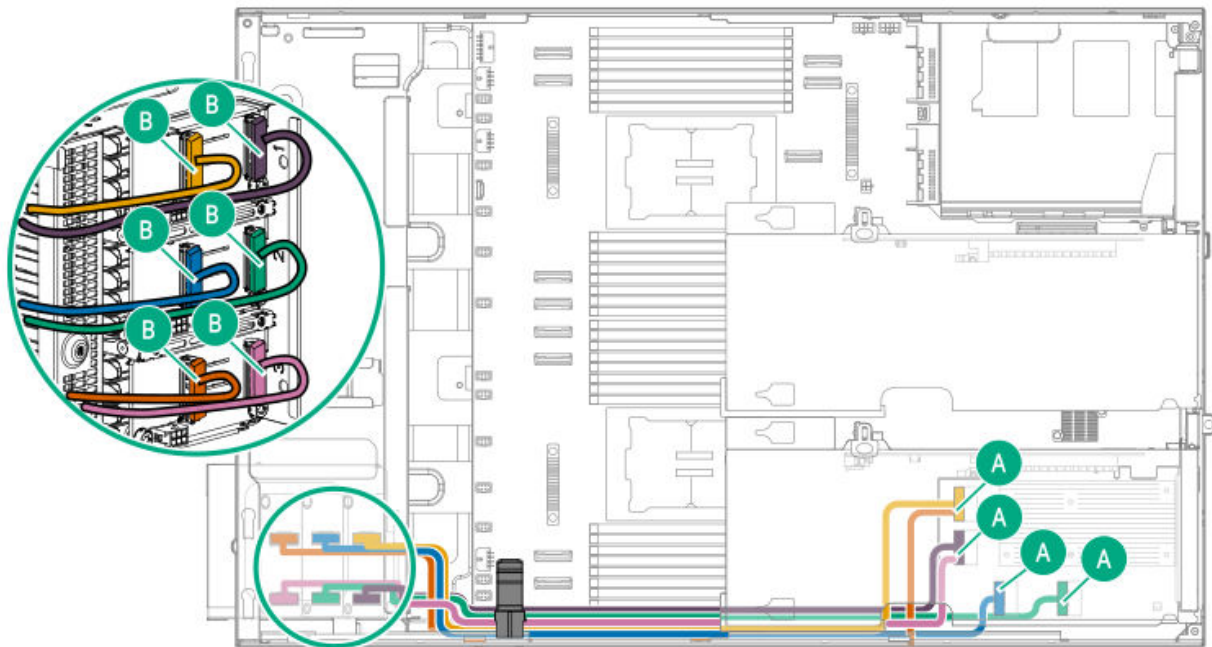

Cable part number	Color	From	To
P75570-001	Orange	Backplane 3 port 2	Type-p controller port 2
	Blue	Backplane 2 port 2	Type-p controller port 4
	Gold	Backplane 1 port 2	Type-p controller port 2
	Pink	Backplane 3 port 1	Type-p controller port 1
	Green	Backplane 2 port 1	Type-p controller port 3
	Purple	Backplane 1 port 1	Type-p controller port 1

Mixed drive controller cabling

4 LFF + 16 SFF drive controller cabling



Cable part number	Color	From	To
P45296-001	Orange	Box 1 port 1	Type-p controller port 2
	Blue	Box 2 port 1	Type-p controller port 1
P49936-001	Gold	Box 3 port 1	Type-p controller port 1

Storage controller backup power cabling

The exact route of the storage controller backup power cabling will depend on:

- The riser slot where the controller is installed
- The location of the storage controller backup power connector on the controller

Use the following diagrams for reference only.



Cable part number	Color	From	To
—	Orange	Type-o controller	OCP slot A storage backup power connector
	Blue		OCP slot B storage backup power connector

Energy pack cabling

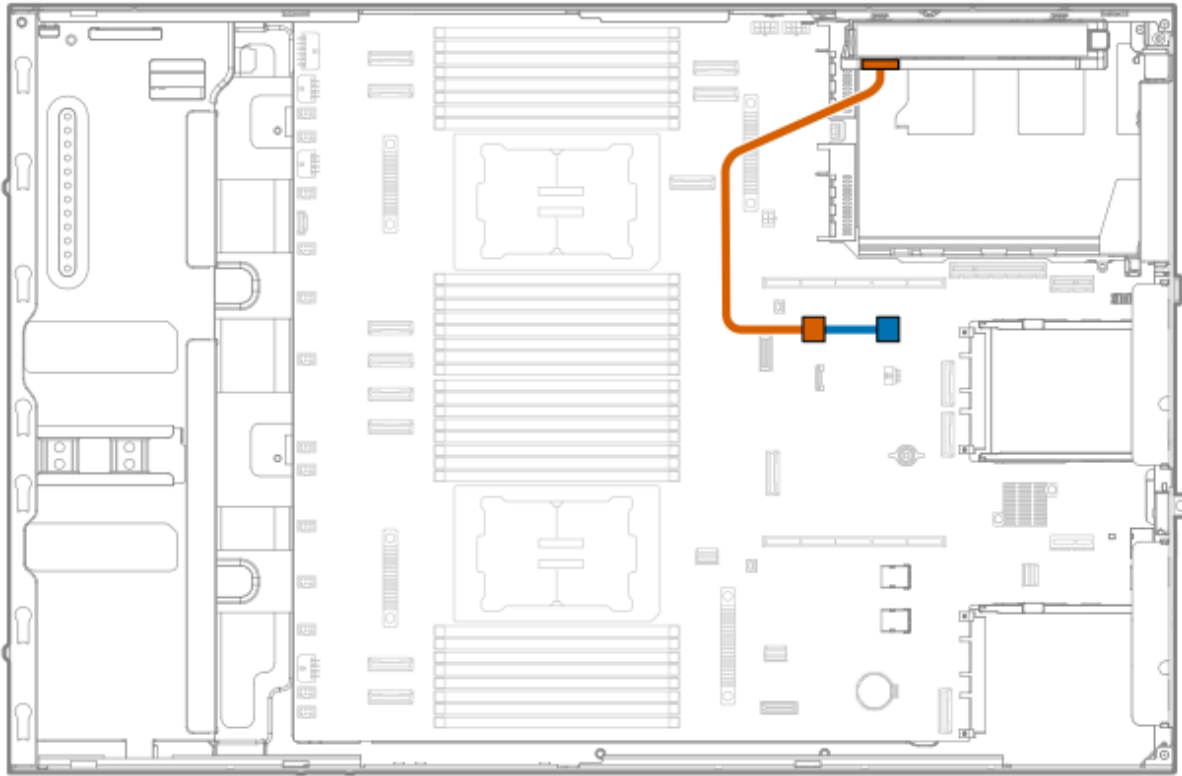

Cable part number	Color	From	To
873905-001	Blue	Energy pack cable	Energy pack connector

Media device cabling

Subtopics

[LTO tape drive cabling](#)

[Optical drive cabling](#)

LTO tape drive cabling

Type-o controller



Cable part number	Color	From	To
P45303-001	Orange	LTO power connector	LTO power connector on the tertiary riser
P49007-001	Blue	SAS connector of the LTO tape drive	Type-o storage controller port 1

Type-p controller

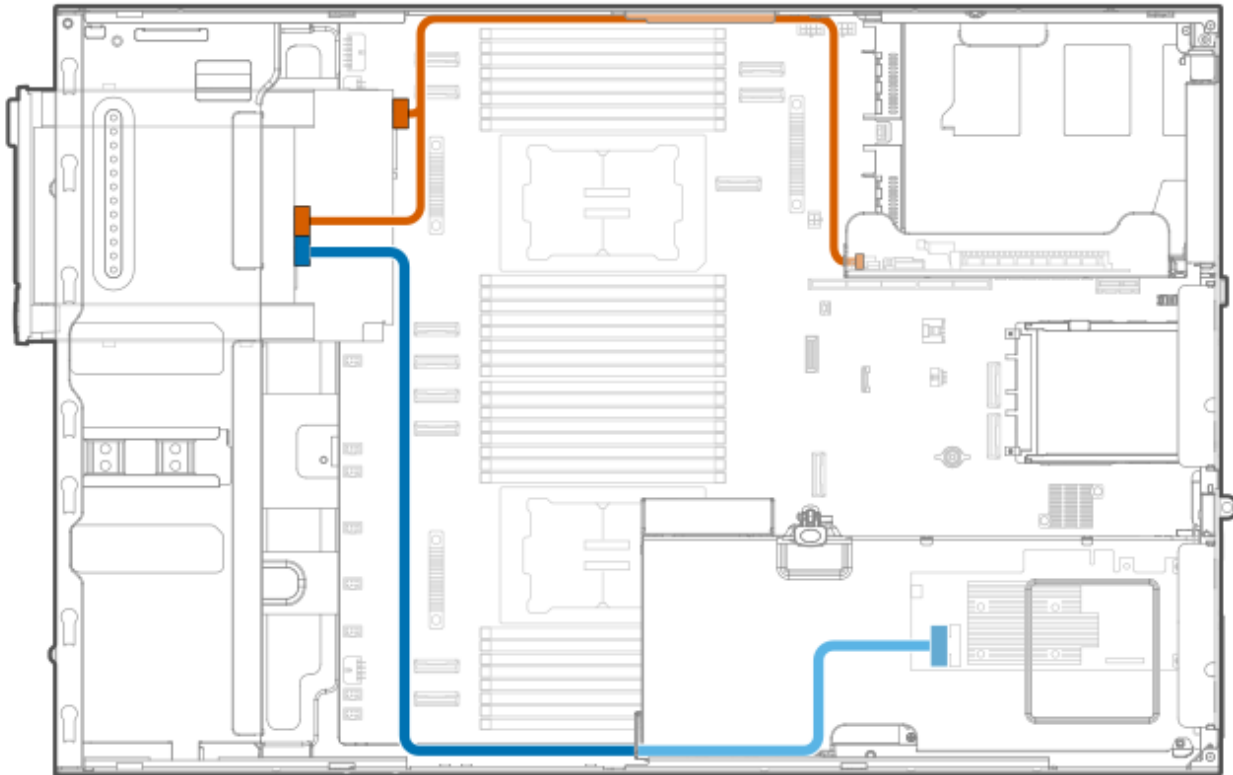

Cable part number	Color	From	To
P45303-001	Orange	LTO power connector	LTO power connector on the tertiary riser
P49006-001	Blue	SAS connector of the LTO tape drive	Type-p storage controller port 1

Optical drive cabling

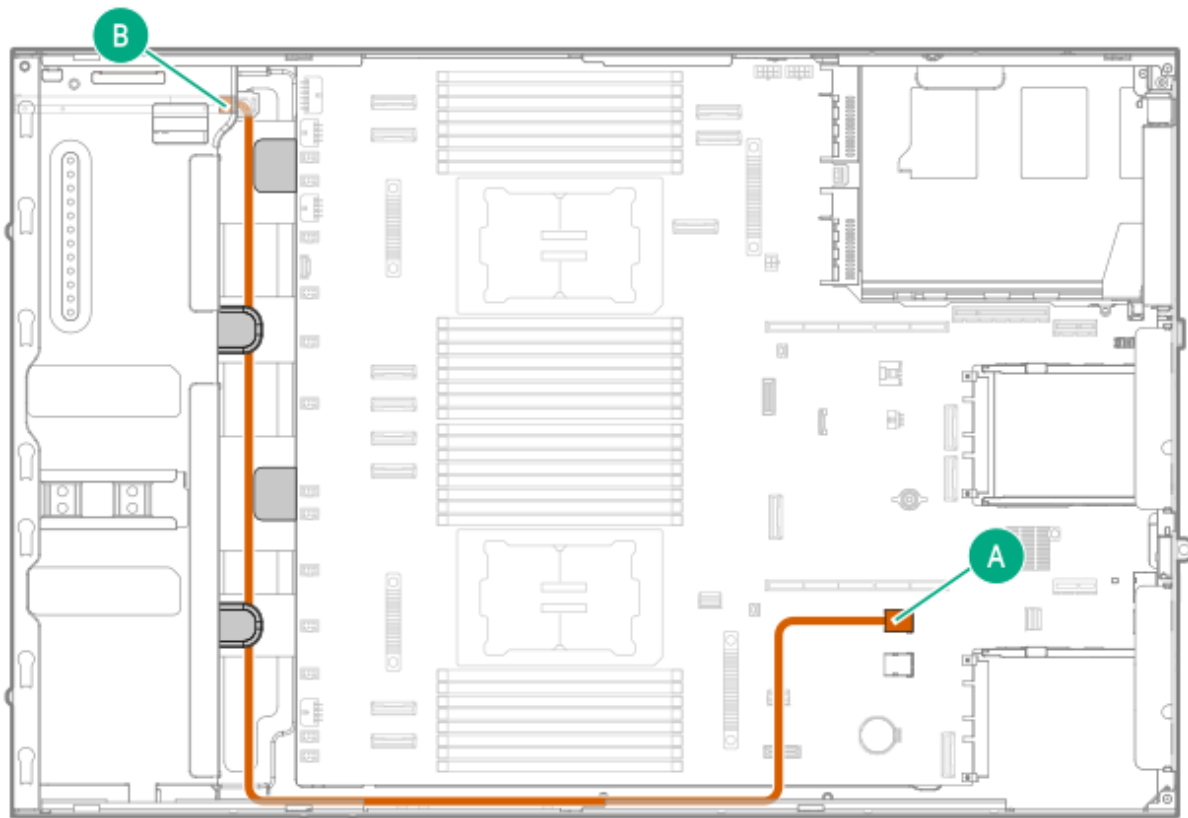

Cable part number	Color	From	To
P73776-002 ¹ / _—	Orange	Optical drive	Dual USB 3.2 Gen 1 ports

¹/_— This cable ships with the optical drive option.

HPE NS204i-u Boot Device V2 cabling

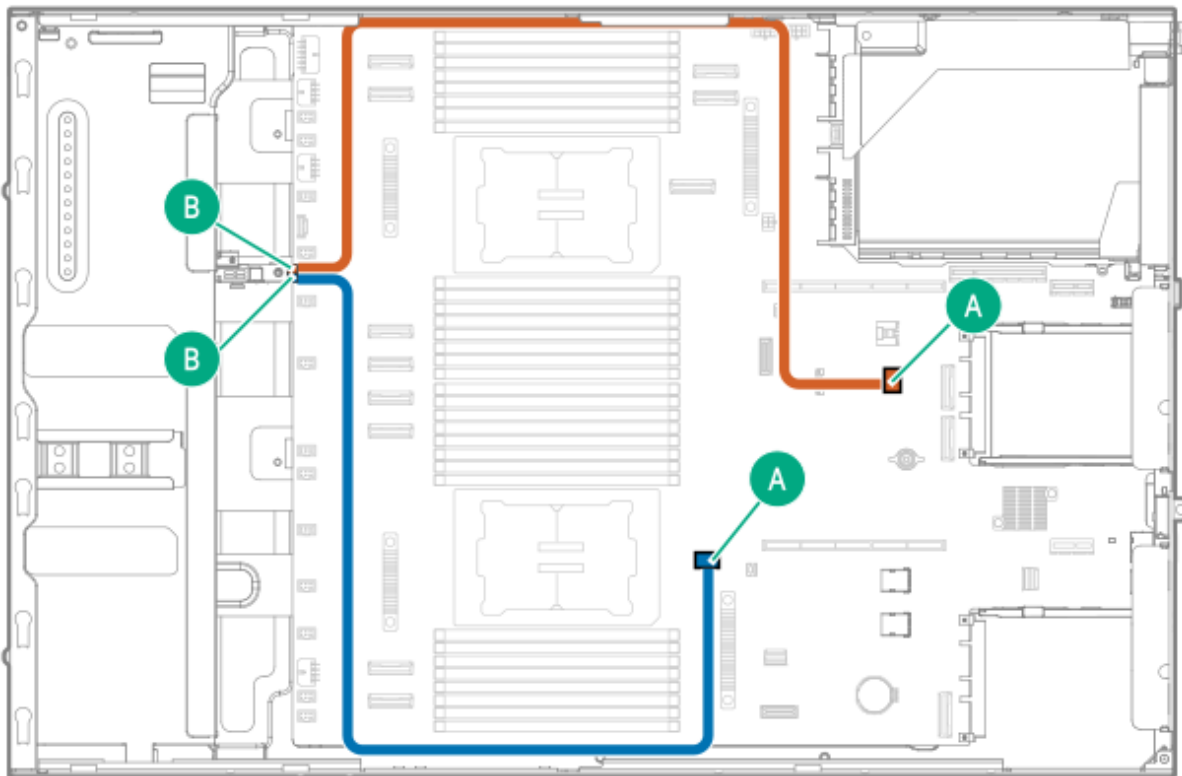

Cable part number	Color	From	To
P48956-001	Orange	Boot device power connector	NS204i-u power connector
P74730-001	Blue	Boot device signal connector	NS204i-u signal connector

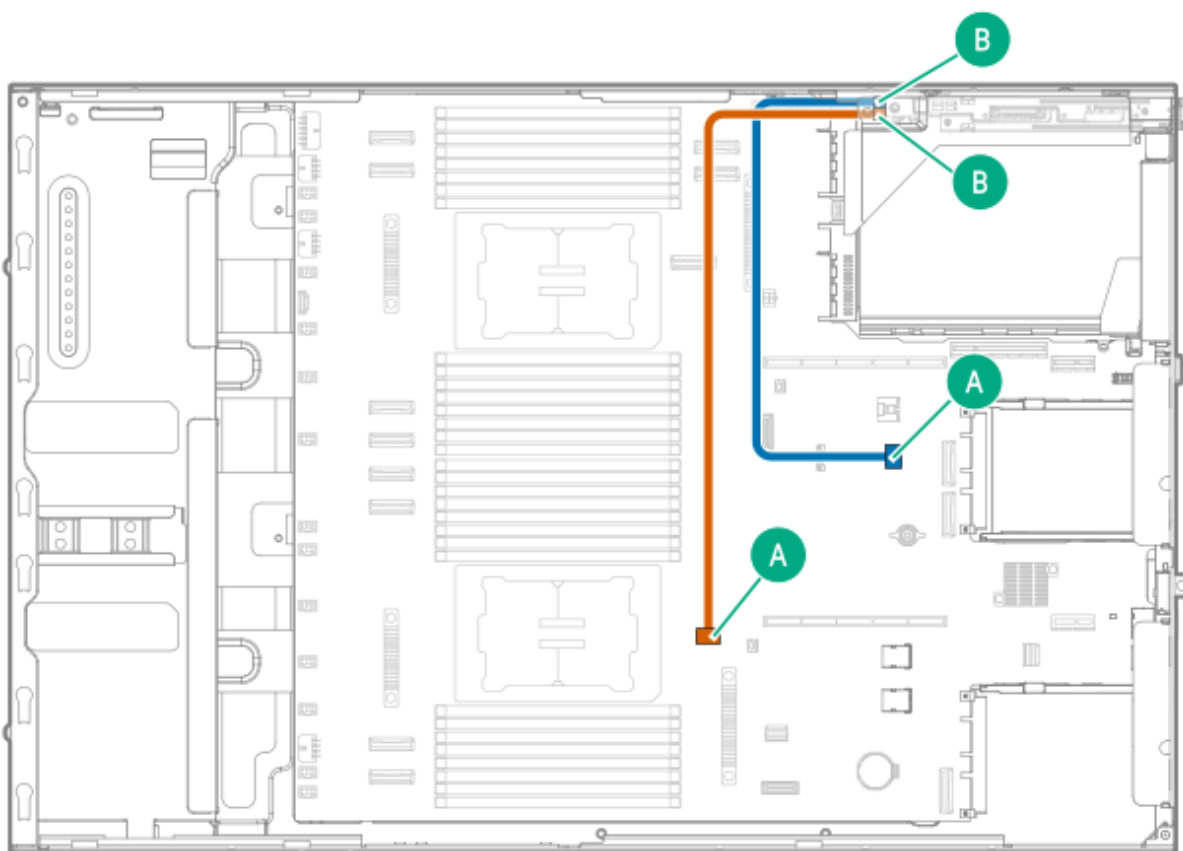

Cable part number	Color	From	To
P72024-001	Orange	Boot device signal connector	NS204i-u signal connector
P54089-001	Blue	Boot device power connector	NS204i-u power connector

GPU auxiliary power cabling

The exact route of the GPU auxiliary power cabling will depend on the:

- The riser cage where the GPU is installed.
- The location of the power connector on the GPU.

Use the following diagrams for reference only.

16-pin GPU auxiliary power Y-cable



Cable part number	Color	From	To
P58422-001	Orange	GPU power connector	<u>GPU auxiliary power connector on the PCIe5 2 x16 riser</u>
	Blue		<u>GPU sideband connector on the PCIe5 2 x16 riser</u>

Fan cabling

Internal fans 1-8



Cable part number	Color	From	To
P53695-001	Orange	Internal fans 3, 4, 7, and 8	Fan connector 9, 12, 10, 11
P53694-001	Blue	Internal fans 1, 2, 5, and 6	Fan connector 3, 6, 4, 5

External fans 9-10



Cable part number	Color	From	To
P45291-001	Orange	External fan 10	Fan connector 1
	Blue	External fan 9	Fan connector 13

OCP bandwidth enablement cabling

Slot 14 OCP A PCIe x16 configuration



Cable part number	Color	From	To
P74890-001	Orange	MCIO port 12	OCP slot A storage backup power connector

Slot 15 OCP B PCIe x8 configuration (Single-processor configuration)

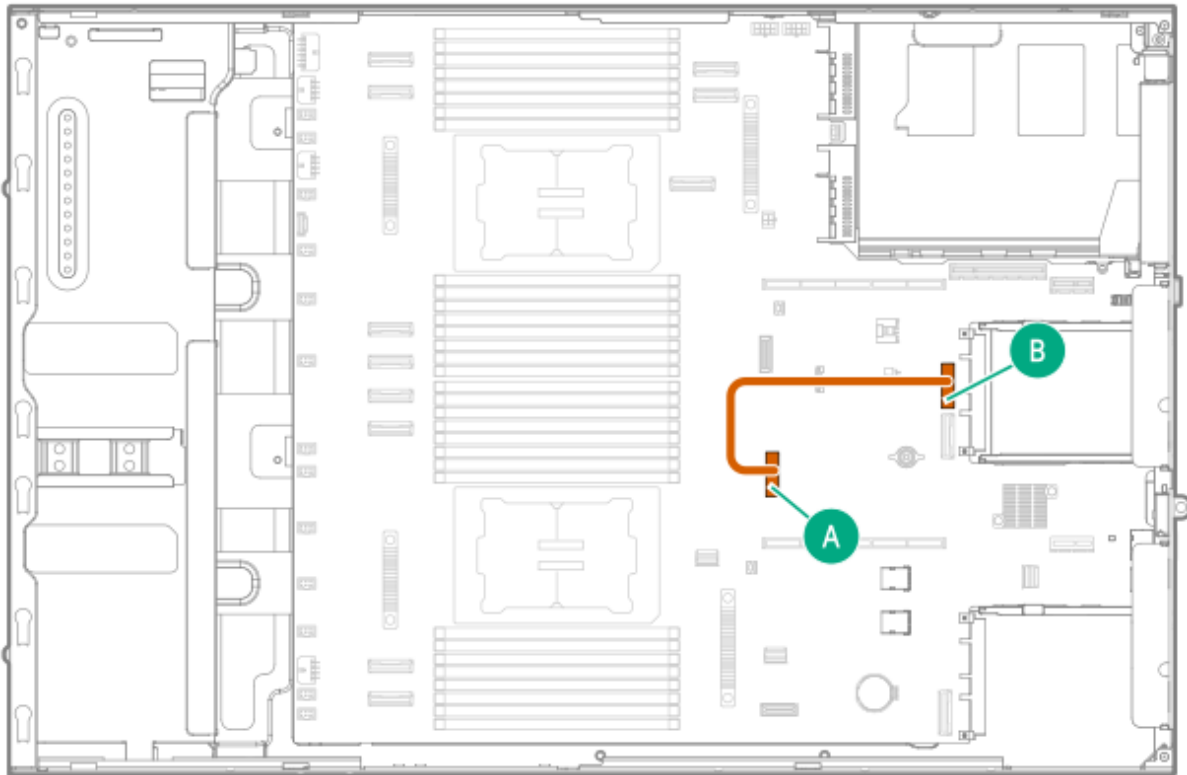

Cable part number	Color	From	To
P74889-001	Orange	MCIO port 12	OCP B internal port 1

Slot 15 OCP B PCIe x16 configuration (Dual-processor configuration)

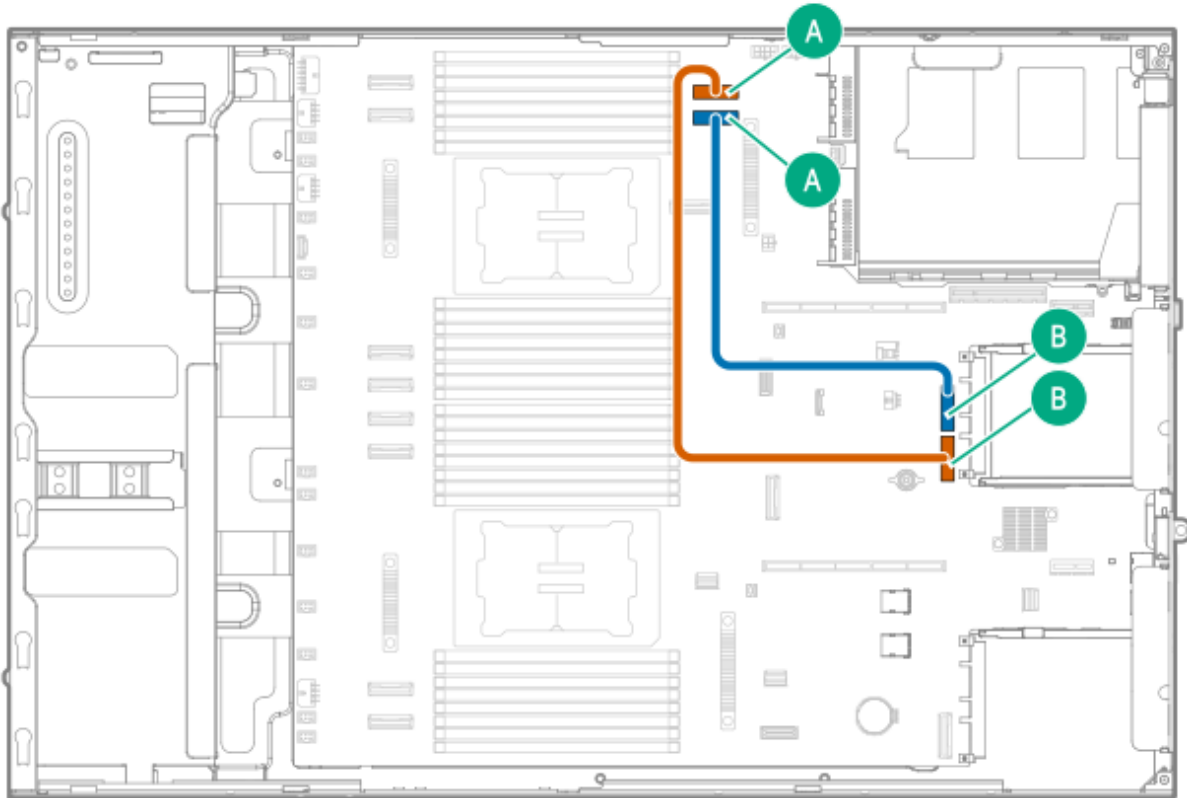

Cable part number	Color	From	To
P74891-001	Orange	MCIO port 9	OCP B internal port 2
	Blue	MCIO port 10	OCP B internal port 1

Tertiary riser signal cabling

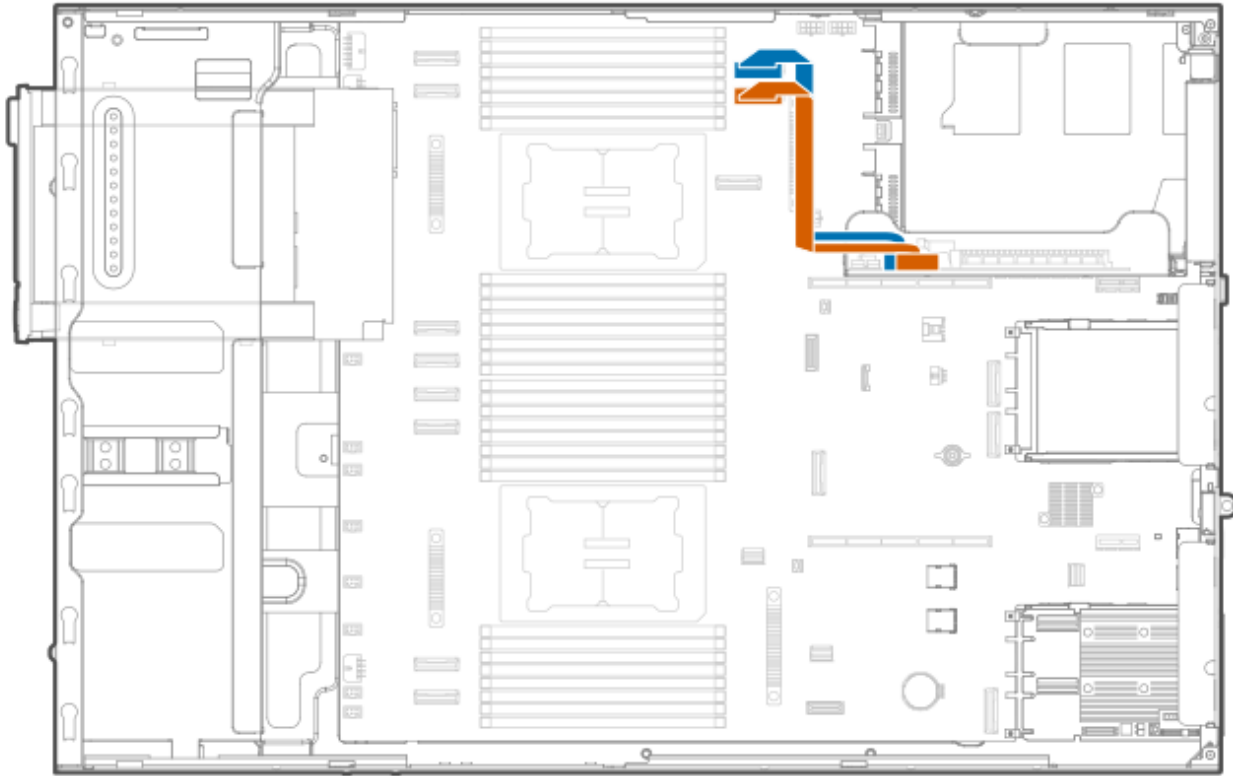

Cable part number	Color	From	To
P79969-001	Blue	M-XIO port 9	PCIe SlimSAS port 3
	Orange	M-XIO port 10	PCIe SlimSAS port 1

Serial port cabling



Cable part number	Color	From	To
P45623-001	Orange	Serial port	Serial port cable connector

Chassis intrusion detection switch cabling

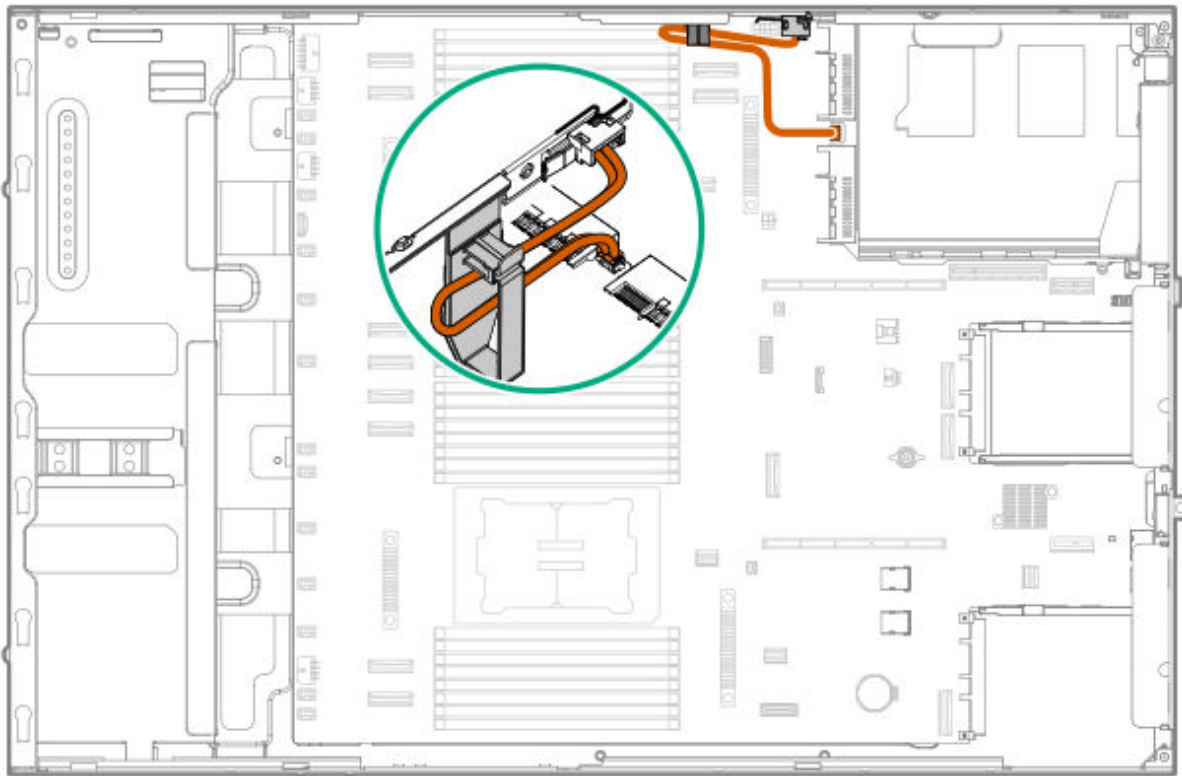

Cable part number	Color	From	To
P47751-001	Orange	Chassis intrusion detection switch	Chassis intrusion detection switch connector

Front I/O cabling

The front I/O cables are preinstalled in the server.

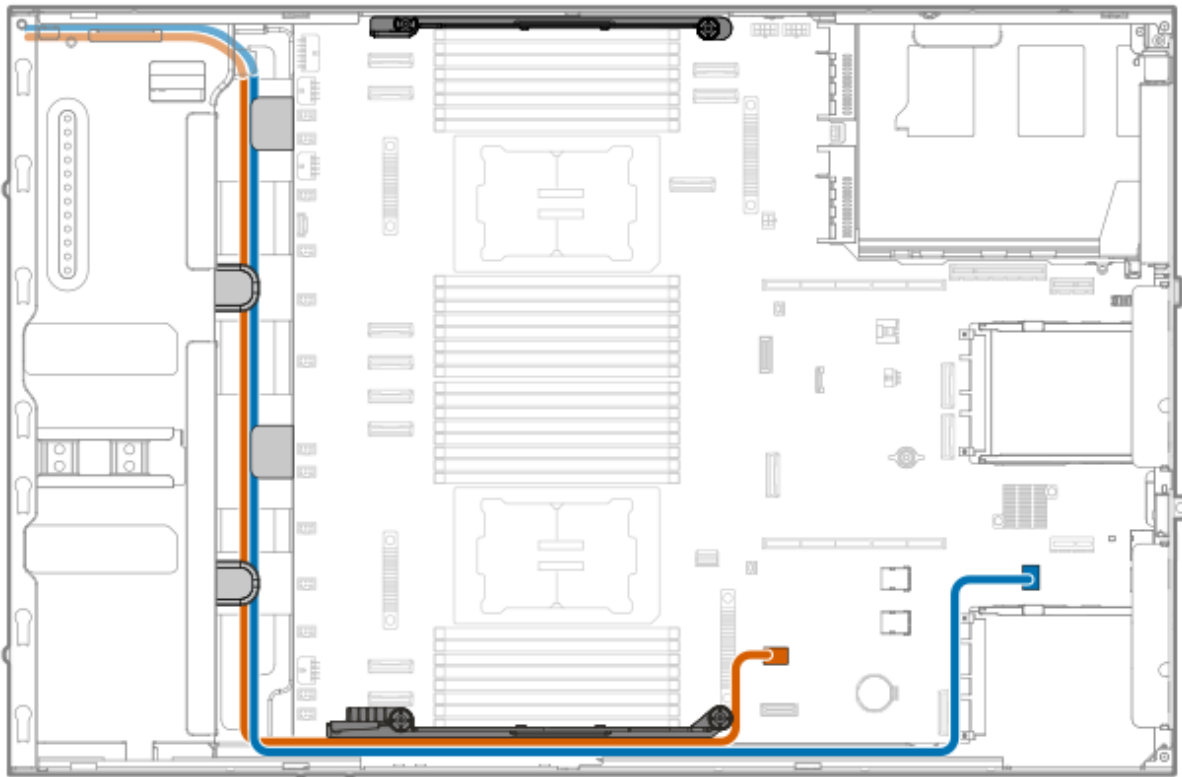

Cable part number	Color	From	To
P71909-001	Orange	Front I/O cage	Front I/O connector
P75279-001	Blue		DisplayPort & iLO service port connector

Configuration resources

Use the following resources to find documentation for configuring and managing your server.

- Some utilities might not apply to your server. For information about server compatibility with the products listed in this chapter, see the product QuickSpecs (<https://www.hpe.com/info/quickspecs>).
- Products ordered from HPE Factory Express might have already been configured with some or all the configurations in this chapter. To determine if any additional setup is required, see your HPE Factory Express order.

- For one-stop access to version-specific software and firmware documentation, including the latest product release notes, see this quick links page:

<https://www.hpe.com/support/hpeproductdocs-quicklinks>

Subtopics

[Updating firmware or system ROM](#)

[Configuring the server](#)

[Configuring storage controllers](#)

[Deploying an OS](#)

[Configuring security](#)

[Server management](#)

[Managing Linux-based high performance compute clusters](#)

Updating firmware or system ROM

To	Use
Download service packs	<ul style="list-style-type: none"> • Service Pack for HPE ProLiant <u>https://www.hpe.com/servers/spp/download</u> • Get an overview of SPP and its ecosystem <u>https://www.hpe.com/support/SPP-overview-views-en</u>
Deploy service packs to a single server	Smart Update Manager <u>https://www.hpe.com/support/hpesmartupdatemanager-quicklinks</u>
Deploy service packs to multiple servers	HPE OneView <u>https://www.hpe.com/support/hpeoneview-quicklinks</u>
Updating iLO or system firmware in a single server	iLO user guide <u>https://www.hpe.com/support/hpeilodocs-quicklinks</u>

To	Use
<ul style="list-style-type: none"> • Enable policy-based management of server or server group firmware for distributed server infrastructure • Monitor server compliance with a configured firmware baseline • Receive automatic iLO firmware updates • Receive baseline update alerts 	<p>HPE Compute Ops Management</p> <p>https://www.hpe.com/support/hpe-gl-com-quicklinks</p>

Configuring the server

To configure	Use
Single server (GUI)	<ul style="list-style-type: none"> • Intelligent Provisioning https://www.hpe.com/support/hpeintelligentprovisioning-quicklinks • iLO remote console or web interface https://www.hpe.com/support/hpeilodocs-quicklinks • UEFI System Utilities https://www.hpe.com/support/hpeuefisystemutilities-quicklinks • HPE Compute Ops Management https://www.hpe.com/support/hpe-gl-com-quicklinks
Single server (scripting)	<ul style="list-style-type: none"> • RESTful Interface Tool https://www.hpe.com/support/restfulinterface/docs

To configure

Use

- Python iLO Redfish Library (python-ilorest-library)
<https://github.com/HewlettPackard/python-ilorest-library>
- Scripting Tools for Windows Powershell
<https://www.hpe.com/info/powershell/docs>
- iLO RESTful API
<https://servermanagementportal.ext.hpe.com/>
- HPE Compute Ops Management API
<https://developer.greenlake.hpe.com/>

Multiple servers (either UI or scripting)

- HPE OneView ¹
<https://www.hpe.com/support/hpeoneview-quicklinks>
- HPE Compute Ops Management
<https://www.hpe.com/support/hpe-gl-com-quicklinks>
 - **Server settings:** Define server-specific parameters such as firmware baselines, and then apply them to server groups.
 - **Server groups:** Organize servers into custom-defined sets with associated server settings, and then apply group-specific policies to create a consistent configuration across the servers in the group.

¹ For servers running HPE OneView, do not use another tool, such as iLO, to delete or change certain settings. For more information about using HPE OneView and iLO to manage the same server, see the iLO user guide at <https://www.hpe.com/support/hpeilodocs-quicklinks>.

Configuring storage controllers

Controller type	Documentation
HPE MR controller user guides	<ul style="list-style-type: none">• HPE MR Gen11 Controller User Guide https://hpe.com/support/MR-Gen11-UG<ul style="list-style-type: none">◦ MR Gen11 controller configuration: https://www.hpe.com/support/MR-Gen11-configuration◦ MR Gen11 controller RAID creation: https://www.hpe.com/support/MR-Gen11-RAID-creation
HPE MR controller configuration guides	<ul style="list-style-type: none">• HPE MR Storage Administrator User Guide https://www.hpe.com/support/MRSA• HPE StorCLI User Guide https://www.hpe.com/support/StorCLI• HPE StorCLI2 User Guide https://www.hpe.com/support/StorCLI2
Intel VROC for HPE Gen12	<ul style="list-style-type: none">• Intel Virtual RAID on CPU for HPE User Guide https://www.hpe.com/support/VROC-UG• Intel VROC NVMe RAID quick installation: https://www.hpe.com/support/VROC-NVMe-RAID-installation <p>OS-specific configuration guides:</p> <ul style="list-style-type: none">• Intel Virtual RAID on CPU (Intel VROC) for Windows User Guide https://docs.graidtech.com/vroc/User_Guides/000094004_Intel_Virtual_RAID_on_CPU_Intel_VROC_User_Guide_for_Windows/

Controller type

Documentation

- Intel Virtual RAID on CPU (Intel VROC) for Linux User Guide

https://docs.graidtech.com/vroc/User_Guides/000094694_Intel_Virtual_RAID_on_CPU_Intel_VROC_User_Guide_for_Linux/

- Intel Volume Management Device Driver for VMware ESXi User Guide

https://docs.graidtech.com/vroc/User_Guides/000094787_Intel_Virtual_RAID_on_CPU_Intel_VROC_User_Guide_for_VMware_ESXi/

Deploying an OS

For a list of supported operating systems, see the HPE Servers Support & Certification Matrices:

<https://www.hpe.com/support/Servers-Certification-Matrices>

To

See

Deploy an OS using HPE Compute Ops Management

HPE Compute Ops Management User Guide

<https://www.hpe.com/support/hpe-gl-com-quicklinks>

Deploy an OS using Intelligent Provisioning

Intelligent Provisioning user guide

<https://www.hpe.com/support/hpeintelligentprovisioning-quicklinks>

Deploy an OS using iLO virtual media

iLO user guide

<https://www.hpe.com/support/hpeilodocs-quicklinks>

Configure the server to boot from a PXE server

UEFI System Utilities User Guide for HPE Compute servers

<https://www.hpe.com/support/UEFIGen12-UG-en>

Configure the server to boot from a SAN

HPE Boot from SAN Configuration Guide

To

See

<https://www.hpe.com/info/boot-from-san-config-guide>

Configuring security

To

See

Implement server security best practices.

- HPE Compute Security Reference Guide

<https://www.hpe.com/info/server-security-reference-en>

- HPE iLO 7 Security Technology Brief

<https://www.hpe.com/support/ilo7-security-en>

Configure and use the Server Configuration Lock feature on HPE Trusted Supply Chain servers and other servers that have the Server Configuration Lock feature enabled.

Server Configuration Lock User Guide for HPE ProLiant servers and HPE Synergy

<https://www.hpe.com/info/server-config-lock-UG-en>

Server management

To monitor

See

Single server

HPE iLO

<https://www.hpe.com/support/hpeilodocs-quicklinks>

Multiple servers

HPE OneView

To monitor	See
	https://www.hpe.com/support/hpeoneview-quicklinks
Single or multiple servers	HPE Compute Ops Management https://www.hpe.com/support/hpe-gl-com-quicklinks

Managing Linux-based high performance compute clusters

To	Use
Provision, manage, and monitor clusters.	HPE Performance Cluster Manager https://www.hpe.com/support/hpcm_manuals
Optimize your applications.	HPE Performance Analysis Tools https://www.hpe.com/info/perftools
Optimize software library for low latency and high bandwidth, both on-node and off-node, for point-to-point and collective communications.	HPE Cray Programming Environment User Guide https://www.hpe.com/info/cray-pe-user-guides

Safety, warranty, and regulatory information

Subtopics

[Regulatory information](#)

[Warranty information](#)

Regulatory information

To view the regulatory information for your product, view the Safety and Compliance Information for Server, Storage, Power, Networking, and Rack Products, available at the Hewlett Packard Enterprise Support Center:

<https://www.hpe.com/support/Safety-Compliance-EnterpriseProducts>

Additional regulatory information

Hewlett Packard Enterprise is committed to providing our customers with information about the chemical substances in our products as needed to comply with legal requirements such as REACH (Regulation EC No 1907/2006 of the European Parliament and the Council). A chemical information report for this product can be found at:

<https://www.hpe.com/info/reach>

For Hewlett Packard Enterprise product environmental and safety information and compliance data, including RoHS and REACH, see:

<https://www.hpe.com/info/ecodata>

For Hewlett Packard Enterprise environmental information, including company programs, product recycling, and energy efficiency, see:

<https://www.hpe.com/info/environment>

Subtopics

[Notices for Eurasian Economic Union](#)

[Turkey RoHS material content declaration](#)

[Ukraine RoHS material content declaration](#)

Notices for Eurasian Economic Union



Manufacturer and Local Representative Information

Manufacturer information:

Hewlett Packard Enterprise Company, 1701 E Mossy Oaks Road, Spring, TX 77389 U.S.

Local representative information Russian:

- **Russia**

ООО "Хьюлетт Паккард Энтерпрайз", Российская Федерация, 125171, г. Москва, Ленинградское шоссе, 16А, стр.3, Телефон: +7 499 403 4248 Факс: +7 499 403 4677

- **Kazakhstan**

ТОО «Хьюлетт-Паккард (К)», Республика Казахстан, 050040, г. Алматы, Бостандыкский район, проспект Аль-Фараби, 77/7, Телефон/факс: + 7 727 355 35 50

Local representative information Kazakh:

- **Russia**

ЖШС "Хьюлетт Паккард Энтерпрайз", Ресей Федерациясы, 125171, Мәскеу, Ленинград тас жолы, 16А блок 3, Телефон: +7 499 403 4248 Факс: +7 499 403 4677

- **Kazakhstan**

ЖШС «Хьюлетт-Паккард (К)», Қазақстан Республикасы, 050040, Алматы к., Бостандык ауданы, Әл-Фараби даңғылы, 77/7, Телефон/факс: +7 727 355 35 50

Manufacturing date:

The manufacturing date is defined by the serial number.

CCSYWWZZZZ (product serial number format)

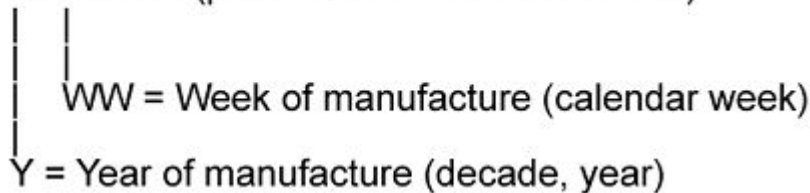

If you need help identifying the manufacturing date, contact tre@hpe.com.

Turkey RoHS material content declaration

Türkiye Cumhuriyeti: AEEE Yönetmeliğine Uygundur

Ukraine RoHS material content declaration

Обладнання відповідає вимогам Технічного регламенту щодо обмеження використання деяких небезпечних речовин в електричному та електронному обладнанні, затвердженого постановою Кабінету Міністрів України від 3 грудня 2008 № 1057

Warranty information

To view the warranty information for your product, see the [warranty check tool](#).

Specifications

Subtopics

[Environmental specifications](#)

[Mechanical specifications](#)

[Power supply specifications](#)

Environmental specifications

Specifications	Value
Temperature range	—
Operating	10°C to 35°C (50°F to 95°F)
Nonoperating	-30°C to 60°C (-22°F to 140°F)
Relative humidity (noncondensing)	—
Operating	8% to 90% 28°C (82.4°F) maximum wet bulb temperature, noncondensing
Nonoperating	5% to 95%

Specifications	Value
	38.7°C (101.7°F) maximum wet bulb temperature, noncondensing
Altitude	—
Operating	3050 m (10,000 ft) This value may be limited by the type and number of options installed. Maximum allowable altitude change rate is 457 m/min (1,500 ft/min).
Nonoperating	9144 m (30,000 ft) Maximum allowable altitude change rate is 457 m/min (1,500 ft/min).

Standard operating support

10° to 35°C (50° to 95°F) at sea level with an altitude derating of 1.0°C per every 305 m (1.8°F per every 1,000 ft) above sea level to a maximum of 3,050 m (10,000 ft), no direct sustained sunlight. Maximum rate of change is 20°C/hr (36°F/hr). The upper limit and rate of change might be limited by the type and number of options installed.

System performance under standard operating support might be reduced if operating above 30°C (86°F) or with a faulty fan installed.

Extended ambient operating support

For approved hardware configurations, the supported system inlet range is extended to be:

- 5° to 10°C (41° to 50°F) and 35° to 40°C (95° to 104°F) at sea level with an altitude derating of 1.0°C per every 175 m (1.8°F per every 574 ft) above 900 m (2,953 ft) to a maximum of 3050 m (10,000 ft).
- 40°C to 45°C (104°F to 113°F) at sea level with an altitude derating of 1.0°C per every 125 m (1.8°F per every 410 ft) above 900 m (2953 ft) to a maximum of 3,050 m (10,000 ft).

The approved hardware configurations for this system are listed in the Extended Ambient Temperature Guidelines for Gen12 Servers:

<https://www.hpe.com/support/ASHRAEGen12>

Mechanical specifications

Tower orientation

Specification	Value
Dimensions	—
Height (with chassis feet)	46.2 cm (18.19 in)

Specification	Value
Height (without chassis feet)	44.5 cm (17.5 in)
Depth (without extended fan)	71.27 cm (28.07 in)
Depth (with extended fan)	74.43 cm (29.30 in)
Width (with chassis feet)	29.36 cm (11.56 in)
Width (without chassis feet)	17.4 cm (6.85 in)
Weight, approximate values	—
Minimum ¹	23.96 kg (58.22 lb)
Maximum ²	45.13 kg (99.49 lb)

¹ The minimum configuration includes 1 SFF drive, 1 processor, 1 DIMM, 1 standard heatsink, 1 power supply, 3 fans and 1 fan blank, primary riser and riser board, and 1 type-o storage controller.

² The maximum configuration includes 12 LFF drives, 1 slim optical disk drive, 2 processors, 32 DIMMs, 2 performance heatsink, 2 power supplies, 8 fans, all risers with riser boards, 2 type-o storage controllers, 4 double-width GPU cards, 2 full-height half-length PCIe cards, and 2 external fans.

Rack orientation

Specification	Value
Dimensions	—
Height (with chassis feet)	29.36 cm (11.56 in)
Height (without chassis feet)	17.4 cm (6.85 in)
Depth (without extended fan)	71.27 cm (28.07 in)
Depth (with extended fan)	74.43 cm (29.30 in)
Width	44.5 cm (17.5 in)
Weight, approximate values	—
Minimum	23.96 kg (58.22 lb)
Maximum	45.13 kg (99.49 lb)

Power supply specifications

Depending on the installed options and the regional location where the server was purchased, the server can be configured with one of the following power supplies. For detailed power supply specifications, see the QuickSpecs on the [Hewlett Packard Enterprise website](#).

Subtopics

[HPE 800 W Flex Slot Platinum Hot-plug Low Halogen Power Supply](#)

[HPE 1000 W Flex Slot Titanium Hot-plug Power Supply](#)

[HPE 1600 W Flex Slot Platinum Hot-plug Low Halogen Power Supply](#)

[HPE 1600 W Flex Slot -48 VDC Hot-plug Power Supply](#)

[HPE 1800-2200 W Flex Slot Titanium Power Supply](#)

HPE 800 W Flex Slot Platinum Hot-plug Low Halogen Power Supply

Specification	Value
Input requirements	—
Rated input voltage	100 VAC to 127 VAC 200 VAC to 240 VAC 240 VDC for China only
Rated input frequency	50 Hz to 60 Hz Not applicable to 240 VDC
Rated input current	9.4 A at 100 VAC 4.5 A at 200 VAC 3.8 A at 240 VDC for China only
Maximum rated input power	940 W at 100 VAC 900 W at 200 VAC 897 W at 240 VDC for China only
BTUs per hour	3067 at 100 VAC 2958 at 200 VAC 2949 at 240 VAC for China only
Power supply output	—
Rated steady-state power	800 W at 100 VAC to 127 VAC input 800 W at 100 VAC to 240 VAC input 800 W at 240 VDC input for China only
Maximum peak power	800 W at 100 VAC to 127 VAC input

Specification	Value
	800 W at 100 VAC to 240 VAC input
	800 W at 240 VDC input for China only

HPE 1000 W Flex Slot Titanium Hot-plug Power Supply

Specification	Value
Input requirements	—
Rated input voltage	100 VAC to 127 VAC 200 VAC to 240 VAC 240 VDC for China
Rated input frequency	50 Hz to 60 Hz
Rated input current	11.3 A at 100 VAC 6.1 A at 200 VAC
Maximum rated input power	1130 W at 100 VAC 1090 W at 200 VAC
BTUs per hour	3764 at 100 VAC 3629 at 200 VAC
Power supply output	—
Rated steady-state power	1000 W at 100 VAC to 127 VAC 1000 W at 200 VAC to 240 VAC input
Maximum peak power	1000 W at 100 VAC to 127 VAC 1000 W at 200 VAC to 240 VAC

HPE 1600 W Flex Slot Platinum Hot-plug Low Halogen Power Supply

Specification	Value
Input requirements	—
Rated input voltage	200 VAC to 240 VAC 240 VDC for China only
Rated input frequency	50 Hz to 60 Hz
Rated input current	8.7 A at 200 VAC 7.5 A at 230 VAC 7.2 A at 240 VDC
Maximum rated input power	1734 W at 200 VAC 1720 W at 240 VAC
BTUs per hour	5918 at 200 VAC 5891 at 230 VAC
Power supply output	—
Rated steady-state power	1600 W at 200 VAC to 240 VAC input 1600 W at 240 VDC input
Maximum peak power	1600 W for 1 ms (turbo mode) at 200 VAC to 240 VAC input

HPE 1600 W Flex Slot -48 VDC Hot-plug Power Supply

Specification	Value
Input requirements	—
Rated input voltage	-40 VDC to -72 VDC
Rated input frequency	DC
Nominal input current	45 A DC at -40 VDC input 36.6 A DC at -48 VDC input

Specification	Value
	24.4 A DC at -72 VDC input
Maximum Rated Input Wattage Rating	1798 W at -40 VDC input 1758 W at -48 VDC input 1755 W at -72 VDC input
BTUs per hour	6026 at -40 VDC input 6000 at -48 VDC input 5989 at -72 VDC input
Power supply output	—
Rated steady-state power	1600 W at -40 VDC to -72 VDC
Maximum peak power	1600 W at -40 VDC to -72 VDC

HPE 1800-2200 W Flex Slot Titanium Power Supply

Specification	Value
Input requirements	—
Rated input voltage	200 VAC to 240 VAC 240 VDC for China only
Rated input frequency	50 Hz to 60 Hz
Rated input current	10 A at 200 VAC 10 A at 240 VAC 10 A at 240 VDC for China only
Maximum rated input power	1946 W at 200 VAC 2375 W at 240 VAC 2375 W at 240 VDC for China only
BTUs per hour	6497 at 200 VAC 7962 at 240 VAC
Power supply output	—

Specification	Value
Rated steady-state power	1800 W at 200 VAC
	2200 W at 240 VAC
Maximum peak power	2200 W for 1 ms (turbo mode) at 200 VAC to 240 VAC input

Websites

General websites

Single Point of Connectivity Knowledge (SPOCK) Storage compatibility matrix

<https://www.hpe.com/storage/spock>

Product white papers and analyst reports

<https://www.hpe.com/us/en/resource-library>

For additional websites, see [Support and other resources](#).

Product websites

HPE ProLiant Compute ML350 Gen12 Server user documents

<https://www.hpe.com/info/ml350gen12-docs>

Support and other resources

- [Accessing Hewlett Packard Enterprise Support](#)
- [Accessing updates](#)
- [Remote support](#)
- [Warranty information](#)
- [Regulatory information](#)
- [Documentation feedback](#)

Subtopics

Accessing Hewlett Packard Enterprise Support

HPE product registration

Accessing updates

Remote support

Documentation feedback

Accessing Hewlett Packard Enterprise Support

- For live assistance, go to the Contact Hewlett Packard Enterprise Worldwide website:

<https://www.hpe.com/info/assistance>

- To access documentation and support services, go to the Hewlett Packard Enterprise Support Center website:

<https://www.hpe.com/support/hpesc>

Information to collect

- Technical support registration number (if applicable)
- Product name, model or version, and serial number
- Operating system name and version
- Firmware version
- Error messages
- Product-specific reports and logs
- Add-on products or components
- Third-party products or components

HPE product registration

To gain the full benefits of the Hewlett Packard Enterprise Support Center and your purchased support services, add your contracts and products to your account on the HPESC.

- When you add your contracts and products, you receive enhanced personalization, workspace alerts, insights through the dashboards, and easier management of your environment.

- You will also receive recommendations and tailored product knowledge to self-solve any issues, as well as streamlined case creation for faster time to resolution when you must create a case.

To learn how to add your contracts and products, see <https://www.hpe.com/info/add-products-contracts>.

Accessing updates

- Some software products provide a mechanism for accessing software updates through the product interface. Review your product documentation to identify the recommended software update method.
- To download product updates:

Hewlett Packard Enterprise Support Center

<https://www.hpe.com/support/hpesc>

My HPE Software Center

<https://www.hpe.com/software/hpesoftwarecenter>

- To subscribe to eNewsletters and alerts:

<https://www.hpe.com/support/e-updates>

- To view and update your entitlements, and to link your contracts and warranties with your profile, go to the Hewlett Packard Enterprise Support Center **More Information on Access to Support Materials** page:

<https://www.hpe.com/support/AccessToSupportMaterials>



IMPORTANT

Access to some updates might require product entitlement when accessed through the Hewlett Packard Enterprise Support Center. You must have an HPE Account set up with relevant entitlements.

Remote support

Remote support is available with supported devices as part of your warranty or contractual support agreement. It provides intelligent event diagnosis, and automatic, secure submission of hardware event notifications to Hewlett Packard Enterprise, which initiates a fast and accurate resolution based on the service level of your product. Hewlett Packard Enterprise strongly recommends that you register your device for remote support.

If your product includes additional remote support details, use search to locate that information.

HPE Get Connected

<https://www.hpe.com/services/getconnected>

HPE Tech Care Service

<https://www.hpe.com/services/techcare>

HPE Complete Care Service

<https://www.hpe.com/services/completecure>

Documentation feedback

Hewlett Packard Enterprise is committed to providing documentation that meets your needs. To help us improve the documentation, click the **Feedback** button on the page of an opened document on the Hewlett Packard Enterprise Support Center portal (<https://www.hpe.com/support/hpesc>). Use this feature to send any errors, suggestions, or comments. This process captures all document information.