



HPE ProLiant Compute DL360 Gen12 Maintenance and Service Guide

Part Number: 30-2D0CFBCA-006

Published: April 2026

Edition: 6

HPE ProLiant Compute DL360 Gen12 Maintenance and Service Guide

Abstract

This document is for the person who installs, administers, and troubleshoots servers and storage systems. Hewlett Packard Enterprise assumes you are qualified in the servicing of computer equipment and trained in recognizing hazards in products with hazardous energy levels.

Part Number: 30-2D0CFBCA-006

Published: April 2026

Edition: 6

© Copyright 2025–2026 Hewlett Packard Enterprise Development LP

Notices

The information provided here is subject to change without notice. Hewlett Packard Enterprise's products and services are covered only by the express warranty statements that come with them. This document does not constitute an additional warranty. Hewlett Packard Enterprise is not responsible for any technical or editorial errors or omissions in this document.

Confidential computer software. You must have a valid license from Hewlett Packard Enterprise to possess, use, or copy the software. In accordance with FAR 12.211 and 12.212, Commercial Computer Software, Computer Software Documentation, and Technical Data for Commercial Items are licensed to the U.S. Government under the vendor's standard commercial license.

Links to third-party websites will take you outside of the Hewlett Packard Enterprise website. Hewlett Packard Enterprise has no control over and is not responsible for the information outside the Hewlett Packard Enterprise website.

Acknowledgments

Intel®, the Intel logo, and Xeon® are trademarks of Intel Corporation in the U.S. and other countries.

Kensington® is a registered trademark of ACCO Brands.

Linux® is the registered trademark of Linus Torvalds in the U.S. and other countries.

Microsoft® and Windows® are either registered trademarks or trademarks of Microsoft Corporation in the United States and/or other countries.

VMware®, VMware NSX®, VMware vCenter®, and VMware vSphere® are registered trademarks or trademarks of VMware, Inc. and its subsidiaries in the United States and other jurisdictions.

All third-party marks are property of their respective owners.

Table of contents

Customer self repair	
Illustrated parts catalog.....	11
Mechanical components.....	11
Chassis ear spare parts.....	12
Energy pack retention latch spare part.....	13
Access panel spare part.....	13
PCIe riser cage spare part.....	13
Front bezel spare part.....	14
Drive box blank spare part.....	14
Drive blank spare parts.....	14
E3.S drive filler spare part.....	15
Air baffle spare part.....	15
Miscellaneous blank spare parts.....	15
Cable management arm spare part.....	16
Rack mounting hardware spare parts.....	16
System components.....	16
Processor spare parts	
System board assembly spare part.....	17
DIMM spare parts.....	18
Drive cable spare parts	
Drive backplane power cable spare parts.....	18
Closed-loop liquid cooling solution spare parts.....	19
Direct liquid cooling module spare parts.....	19
Fan spare parts.....	20
Heatsink spare parts.....	20
Power supply spare parts.....	20
Battery and capacitor spare parts.....	21
Server options.....	22
Drive cage spare parts.....	23
Drive backplane spare parts.....	23
Chassis intrusion detection switch spare part.....	24
PCIe riser board spare parts.....	24
Front NS204i-u bracket spare part.....	25
Storage controller spare parts.....	25

HPE NS204i-u Boot Device V2 spare parts.....	26
System Insight Display spare parts.....	27
Front DisplayPort / USB spare parts.....	27
Optical drive cable spare part.....	28
OCP enablement cable spare parts.....	28
Front OCP NIC cable spare part.....	28
Front OCP NIC carrier spare part.....	29
PHY board spare part.....	29
OCP NIC interposer and cable spare parts	
Removal and replacement procedures	
Safety considerations.....	29
Electrostatic discharge.....	30
Symbols on equipment.....	31
Rack warnings and cautions.....	36
Server warnings and cautions.....	38
Preparation procedures.....	39
Server data backup.....	39
Power down the server.....	40
Extend the server from the rack.....	41
Release the cable management arm.....	42
Remove the server from the rack.....	43
Remove the access panel.....	45
Remove the air baffle	
Remove the middle cover.....	46
Remove the fan wall.....	47
Remove the primary PCIe riser cage.....	50
Power up the server.....	51
Removing and replacing the front bezel	
Removing and replacing the cable management arm.....	51
Rack rail replacement.....	56
Rack mounting interfaces	
Removing and replacing the friction rack rails.....	56
Removing and replacing a hot-plug SAS, SATA or NVMe drive.....	60
Removing and replacing a drive blank.....	61
Removing and replacing a drive box blank.....	63
Removing and replacing an E3.S drive cage filler.....	64
Removing and replacing a hot-plug E3.S drive	
Chassis ear replacement.....	65

Removing and replacing the left chassis ear.....	65
Removing and replacing the right chassis ear and power switch board.....	66
Removing and replacing a power supply blank.....	71
Flexible Slot power supply replacement.....	72
Power supply warnings and cautions.....	73
DC power supply warnings and cautions.....	74
DC power supply wire colors.....	75
Removing and replacing a hot-plug AC power supply.....	75
Removing and replacing a DC Flexible Slot power supply.....	79
Removing and replacing the System Insight Display.....	83
Front OCP NIC kit replacement.....	85
Removing and replacing a front OCP NIC or carrier kit.....	86
Removing and replacing the front OCP NIC cable.....	88
Removing and replacing the OCP NIC interposer.....	92
Fan replacement.....	93
Requirements for redundant fan support.....	94
Removing and replacing a fan.....	94
Removing and replacing a fan blank.....	98
Media device replacement	
Removing and replacing the optical drive / DisplayPort / USB in the 4 LFF server.....	99
Removing and replacing the DisplayPort / USB / optical drive in the 8 SFF server.....	100
Removing and replacing a DisplayPort / USB / optical drive in drive boxes 4–5.....	103
Drive backplane replacement.....	104
Removing and replacing the 4 LFF drive backplane.....	105
Removing and replacing the 8 SFF drive backplane.....	107
Removing and replacing the 2 SFF drive backplane in the 8 + 2 SFF drive configuration.....	108
Removing and replacing the stacked 2 SFF / 4 E3.S drive backplane in the 10 SFF / 20 E3.S server.....	110
Removing and replacing an energy pack.....	114
Removing and replacing the energy pack retention latch.....	116
Removing and replacing a DIMM.....	118
Removing and replacing a DIMM blank.....	120
Removing and replacing a riser cage.....	122
Removing and replacing an expansion card.....	125
HPE NS204i-u Boot Device V2 replacement.....	128
Removing and replacing a boot device drive.....	128
Removing and replacing the boot device cage.....	133

Removing and replacing a primary riser board.....	139
Removing and replacing the secondary low-profile riser.....	142
Removing and replacing the serial port.....	144
Removing and replacing the chassis intrusion detection switch.....	145
Removing and replacing a rear OCP 3.0 network adapter.....	146
Removing and replacing a type-o storage controller.....	148
Removing and replacing a type-p storage controller.....	150
System battery replacement	
System battery information.....	153
Removing and replacing the system battery.....	153
Heatsink replacement.....	156
Removing a standard or high performance heatsink.....	156
Installing a standard or high performance heatsink.....	166
Liquid cooling module replacement.....	182
Removing the closed-loop liquid cooling module from the system board.....	183
Installing the closed-loop liquid cooling module on the system board.....	199
Disconnecting the direct liquid cooling kit.....	219
Removing the DLC cold plate module from the system board	
Installing the DLC cold plate module on the system board.....	221
Processor replacement.....	244
Processor cautions.....	245
Removing a processor.....	245
Installing a processor.....	255
System board replacement.....	271
Removing the system board assembly.....	271
Installing the system board assembly.....	279
Re-entering the server serial number and product ID.....	286
Component identification.....	287
Front panel components.....	288
Front panel LEDs and buttons.....	292
UID button functionality.....	293
System Insight Display LEDs.....	293
System Insight Display combined LED descriptions.....	295
Rear panel components.....	297
Rear panel LEDs.....	299
Component touchpoints.....	300
System board components.....	302
System maintenance switch descriptions.....	304

DIMM label identification.....	305
DIMM slot locations.....	306
PCIe connector and processor matrix.....	306
Drive bay numbering.....	307
Drive backplane naming.....	309
OCP NIC 3.0 slot numbering.....	310
HPE Basic Drive LED definitions.....	312
EDSFF SSD LED definitions.....	313
Fan numbering.....	314
Fan and heatsink requirements.....	315
Heatsink and processor socket components.....	318
Closed-loop liquid cooling (CLLC) module components.....	318
DLC module components	
Liquid cooling guidelines.....	319
HPE NS204i-u Boot Device V2 components.....	321
HPE NS204i-u Boot Device V2 LED definitions	322
Riser board components.....	323
Riser slot numbering.....	325
Troubleshooting.....	325
NMI functionality.....	326
Front panel LED power fault codes.....	326
Troubleshooting resources.....	327
Cabling	
Cabling guidelines.....	327
Cabling diagrams.....	329
Internal cabling management.....	336
Storage cabling.....	336
4 LFF drive backplane cabling.....	337
8 SFF drive backplane cabling.....	338
8 + 2 SFF drive backplane cabling.....	340
4 E3.S stacked drive backplane cabling.....	356
Drive Box 1 cabling.....	357
Drive Box 2 cabling	
Drive Box 3 cabling.....	359
Drive Box 4 cabling.....	361
Drive Box 5 cabling.....	364
Drive box cabling for Boxes 1–2.....	366
Drive box cabling for boxes 1 and 4.....	369

Drive box cabling for boxes 1 and 5.....	370
Drive box cabling for boxes 4–5.....	371
2 SFF stacked drive backplane cabling.....	372
Drive Box 1 cabling.....	373
Drive Box 2 cabling	
Drive Box 3 cabling.....	375
Drive Box 4 cabling.....	380
Drive Box 5 cabling	
Drive box cabling for boxes 1–2.....	386
Drive box cabling for boxes 4–5.....	391
Drive box cabling for boxes 1–5.....	396
Storage controller backup power cabling.....	397
Drive power cabling.....	399
Energy pack cabling	
Optical drive cabling.....	403
Front DisplayPort / USB cabling.....	406
Internal boot device cabling.....	408
Front OCP NIC cabling.....	413
OCP bandwidth enablement cabling.....	415
Serial port cabling.....	418
Chassis intrusion detection switch cabling.....	418
Front I/O cabling.....	419
System Insight Display cabling.....	419
Liquid cooling module cabling.....	420
Configuration resources.....	420
Updating firmware or system ROM.....	421
Configuring the server.....	422
Configuring storage controllers.....	424
Deploying an OS.....	425
Configuring security.....	426
Server management.....	427
Managing Linux-based high performance compute clusters.....	427
Safety, warranty, and regulatory information.....	427
Regulatory information.....	428
Notices for Eurasian Economic Union.....	428
Turkey RoHS material content declaration.....	429
Ukraine RoHS material content declaration.....	430
Warranty information.....	430

Specifications.....	430
Environmental specifications.....	430
Server and rackmounting specifications.....	432
Power supply specifications.....	434
HPE 800 W Flex Slot Platinum Hot-plug Low Halogen Power Supply.....	434
HPE 1000 W Flex Slot Titanium Hot-plug Power Supply.....	435
HPE 1600 W Flex Slot Platinum Hot-plug Low Halogen Power Supply.....	436
HPE 1600 W Flex Slot -48 VDC Hot-plug Power Supply.....	436
HPE 1800-2200 W Flex Slot Titanium Power Supply.....	437
Support and other resources.....	438
Accessing Hewlett Packard Enterprise Support.....	438
HPE product registration.....	439
Accessing updates.....	439
Remote support.....	440
Documentation feedback.....	441
Appendix I: Server coolant spill response.....	441
Eye and skin protection.....	441
Server coolant leak.....	441

Illustrated parts catalog

Provides spare part numbers for serviceable hardware components and their corresponding customer self repair (CSR) information.

Subtopics

[Mechanical components](#)

[System components](#)

[Server options](#)

Mechanical components

Hewlett Packard Enterprise continually improves and changes product parts. For complete and current supported parts information, see the [Hewlett Packard Enterprise PartSurfer website](#).

https://sketchfab.com/models/5a24c4180fb84e5fb4683a73438cc412/embed?ui_infos=0&ui_watermark=0&ui_help=0&ui_vr=0&ui_settings=0&ui_inspector=0&ui_hint=2&ui_color=01a982&ui_theme=dark&autostart=1&camera=0&ui_animations=0

Item	Description
1	<u>Right chassis ear spare part</u>
2	<u>Left chassis ear spare part</u>
3	<u>Energy pack retention latch spare part</u>
4	<u>Access panel spare part</u>
5	<u>PCIe riser cage spare part</u>
6	<u>Front bezel spare part</u> *
7	<u>Drive box blank spare part</u> *
8	<u>Drive blank spare parts</u> *
9	<u>E3.S drive filler spare part</u> *
10	<u>Air baffle spare part</u> *
11	<u>DIMM blank spare part</u> *
12	<u>Cable management arm spare part</u> *
13	<u>Rack mounting hardware spare parts</u> *

Item	Description
14	Miscellaneous blank spare parts *

* Not shown

Subtopics

- [Chassis ear spare parts](#)
- [Energy pack retention latch spare part](#)
- [Access panel spare part](#)
- [PCIe riser cage spare part](#)
- [Front bezel spare part](#)
- [Drive box blank spare part](#)
- [Drive blank spare parts](#)
- [E3.S drive filler spare part](#)
- [Air baffle spare part](#)
- [Miscellaneous blank spare parts](#)
- [Cable management arm spare part](#)
- [Rack mounting hardware spare parts](#)

Chassis ear spare parts

Customer self repair: **Mandatory**

Replacement procedures:

- [Removing and replacing the left chassis ear](#)
- [Removing and replacing the right chassis ear and power switch board](#)

Description	Spare part number
Left chassis ear assembly	P56499-001
Right chassis ear and power switch ¹ _—	P79636-001
Right chassis ear switch board ² _—	P56501-001

¹ This spare part includes the chassis ear with the front I/O and USB cable.

²_— This is a miscellaneous component spare kit; only the switch board listed in this table is used on this server.

Energy pack retention latch spare part

Customer self repair: **Mandatory**

Replacement procedure: Removing and replacing the energy pack retention latch

Description	Spare part number
Energy pack retention latch	875066-001 [*]

* This is a miscellaneous component spare kit; only the energy pack retention latch listed in this table is used on this server.

Access panel spare part

Customer self repair: **Mandatory**

Replacement procedure: Removing and replacing the access panel

Description	Spare part number
Access panel	P56474-001

PCIe riser cage spare part

Customer self repair: **Optional**

Replacement procedure: Removing and replacing a riser cage

Description	Spare part number
Primary riser cage, full-height	P80074-001

For riser board spares, see PCIe riser board spare parts.

Front bezel spare part

Customer self repair: **Mandatory**

Replacement procedure: [Removing and replacing the front bezel](#)

Description	Spare part number
Front bezel	P60140-001

Drive box blank spare part

Customer self repair: **Mandatory**

Replacement procedure: [Removing and replacing a drive box blank](#)

Description	Spare part number
Drive box blank	P76287-001 [*]

* This blank is supported on the 10 SFF / 20 E3.S server or servers supporting mixed drive type in the front drive cage.

Drive blank spare parts

Customer self repair: **Mandatory**

Replacement procedure: [Removing and replacing a drive blank](#)

Description	Spare part number
LFF drive blank	827363-001
SFF drive blank	670033-001
E3.S drive blank	P52488-001

E3.S drive filler spare part

Customer self repair: **Mandatory**

Replacement procedure: Removing and replacing an E3.S drive cage filler

Description	Spare part number
E3.S drive filler	P74372-001

Air baffle spare part

Customer self repair: **Mandatory**

Replacement procedure: Removing and replacing the air baffle

Description	Spare part number
Air baffle	P86431-001

Miscellaneous blank spare parts

Customer self repair: **Mandatory**

Replacement procedures:

- Removing and replacing a power supply blank
- Removing and replacing a DIMM blank

Description	Spare part number
Miscellaneous blanks	P56489-001
<ul style="list-style-type: none">• OCP adapter blank• 2SFF blank• Serial port blank	

Description	Spare part number
<ul style="list-style-type: none"> PCI blank 	
Power supply blank	777301-001
Fan blank	779105-001
DIMM blank	812914-001

Cable management arm spare part

Customer self repair: **Mandatory**

Replacement procedure: [Removing and replacing the cable management arm](#)

Description	Spare part number
Cable management arm #4	P74370-001

Rack mounting hardware spare parts

Customer self repair: **Mandatory**

Replacement procedure: [Removing and replacing the friction rack rails](#)

Description	Spare part number
1U friction rail kit 3 for 8 SFF servers	P58211-001
1U friction rail kit 5 for 4 LFF / 10 SFF / 20 E3.S servers	P59872-001

System components

Hewlett Packard Enterprise continually improves and changes product parts. For complete and current supported parts information, see the [Hewlett Packard Enterprise PartSurfer website](#).

<https://sketchfab.com/models/f300c6ea43a34d9fa170d74dea5ae1cd/embed?>

Item	Description
1	High performance fan spare part
2	Standard heatsink spare part
3	Processor spare parts
4	DIMM spare parts
5	Power supply spare parts
6	System battery spare part
7	System board assembly spare part
8	Liquid cooling fan spare part *
9	High performance heatsink spare part *
10	Drive cable spare parts *
11	Backplane power cable spare parts *
12	Closed-loop liquid cooling (CLLC) solution spare parts *
13	Direct liquid cooling (DLC) module spare parts *

* Not shown

Subtopics

[Processor spare parts](#)

[System board assembly spare part](#)

[DIMM spare parts](#)

[Drive cable spare parts](#)

[Drive backplane power cable spare parts](#)

[Closed-loop liquid cooling solution spare parts](#)

[Direct liquid cooling module spare parts](#)

[Fan spare parts](#)

[Heatsink spare parts](#)

[Power supply spare parts](#)

[Battery and capacitor spare parts](#)

System board assembly spare part

Customer self repair: **Optional**

Replacement procedure: [Removing and replacing the system board](#)

Description	Spare part number
System board assembly	P77347-001
System board assembly (for China only)	P77348-001

DIMM spare parts

[Customer self repair](#): **Mandatory**

Replacement procedure: [Removing and replacing a DIMM](#)

Description	Spare part number
16 GB, single-rank x8 PC5-6400B-R	P71254-001
32 GB, dual-rank x8 PC5-6400B-R	P71255-001
64 GB, dual-rank x4 PC5-6400B-R	P71256-001
96 GB, dual-rank x4 PC5-6400B-R	P71257-001
128 GB, dual-rank x4 PC5-6400B-R	P71258-001
256 GB, quad-rank x4 PC5-6400B-R 3DS	P75947-001

Drive backplane power cable spare parts

[Customer self repair](#): **Mandatory**

Cable description and part number	Spare part number
4 LFF backplane power cable: P75565-001	P76964-001
8 SFF backplane power cable: P75566-001	P76965-001
2 SFF backplane power cable: 869667-001	P56475-001
2 SFF / 4 EDSFF stacked backplane power cable: P75316-001	P76967-001

Closed-loop liquid cooling solution spare parts

Customer self repair: **Optional**

Replacement procedure: [Removing and replacing the closed-loop liquid cooling module](#)

Description	Spare part number
Closed-loop liquid cooling module spare kit, includes: <ul style="list-style-type: none">Closed-loop liquid cooling moduleLiquid cooling module handle	P76979-001
Closed-loop liquid cooling fan	P53225-001

Direct liquid cooling module spare parts

Customer self repair: DLC cold plate modules are **Optional**. Hose sets are **Mandatory**.

Replacement procedures:

- [Disconnecting the direct liquid cooling kit](#)
- [Removing and replacing the DLC cold plate module](#)

Description	Spare part number
DLC cold plate module from PCIe	P76980-001
DLC cold plate module from NS204 PCIe Slot 2, includes: <ul style="list-style-type: none">DLC cold plate moduleRear NS204i-u boot device bracket	P83925-001
DLC hose set (FtoM) 76.2 cm / 122 cm QD	P80826-001
DLC hose set (SVRtoMAN) 45 cm QD	P63156-001

Fan spare parts

Customer self repair: **Mandatory**

Replacement procedure: Removing and replacing a fan

Description	Spare part number
Standard fan	P53226-001
High-performance fan	P53227-001

For liquid cooling fans, see Closed-loop liquid cooling solution spare parts.

Heatsink spare parts

Customer self repair: Standard heatsink is **Mandatory**; high performance heatsink is **Optional**.

Replacement procedure: Removing and replacing the heatsink

Description	Spare part number
Standard heatsink	P53219-001
High performance heatsink	P76978-001

Power supply spare parts

Customer self repair: P18510-001 and accessories are **Optional**; all other power supplies are **Mandatory**.

Replacement procedures:

- Removing and replacing a hot-plug AC power supply
- Removing and replacing a DC Flexible Slot power supply

Power supplies

Description	Spare part number
HPE 800 W Flex Slot Platinum Hot-plug Low Halogen Power Supply	P39385-001

Description	Spare part number
HPE 1000 W Flex Slot Titanium Hot-plug Low Halogen Power Supply	P44412-001
HPE 1600 W Flex Slot Platinum Hot-plug Low Halogen Power Supply	P39384-001
HPE 1600 W Flex Slot -48 VDC Hot-plug Power Supply	P18510-001
HPE 1800-2200 W Flex Slot Titanium Power Supply	P47163-001

Accessories

Description	Spare part number
Power cable lug kit for the HPE 1600 W DC power supply	P25161-001

Battery and capacitor spare parts

Customer self repair: **Mandatory**

Replacement procedures:

- [Removing and replacing an energy pack](#)
- [Removing and replacing the system battery](#)
- [Removing and replacing the serial port](#)

Description	Spare part number
HPE 96 W Smart Storage Battery with 145 mm (5.71 in) cable	878643-001
HPE 16 W Smart Storage Hybrid Capacitor with 145 mm (5.71 in) cable	P66825-001
HPE 12 W Smart Storage Hybrid Capacitor with 145 mm (5.71 in) cable	P07473-001
3.3-V lithium battery coin (CR2032)	319603-001
Storage controller enablement and serial port kit, includes:	P56488-001
<ul style="list-style-type: none"> • Energy pack extension cable: P45618-001 • Serial port cable: P45623-001 	

Server options

Hewlett Packard Enterprise continually improves and changes product parts. For complete and current supported parts information, see the [Hewlett Packard Enterprise PartSurfer website](#).

https://sketchfab.com/models/58102ae928a44b84ba1cc01444d66855/embed?ui_infos=0&ui_watermark=0&ui_help=0&ui_vr=0&ui_settings=0&ui_inspector=0&ui_hint=2&ui_color=01a982&ui_theme=dark&autostart=1&camera=0&ui_animati

Item	Description
1	SFF hot-plug drive For more information on the removal and replacement procedures, see Removing and replacing a hot-plug LFF / SFF drive .
2	Drive backplane spare parts
3	NS204i-u boot device spare parts
4	Energy pack spare parts
5	Intrusion detection switch spare part
6	Riser board spare parts
7	Serial port cable spare part
8	Front panel boot device bracket spare part *
9	HPE MR type-o and type-p storage controller spare parts *
10	2 SFF drive cage spare part *
11	4 E3.S drive cage spare part *
12	System Insight Display spare parts *
13	Front DisplayPort / USB spare parts *
14	Optical drive cable spare part *
15	OCP enablement cable spare parts *
16	Front OCP NIC cable spare part *
17	Front OCP NIC carrier spare part *
18	Phy board spare part *
19	OCP NIC interposer and cable spare parts *

*Not shown

Subtopics

- [Drive cage spare parts](#)
- [Drive backplane spare parts](#)
- [Chassis intrusion detection switch spare part](#)
- [PCIe riser board spare parts](#)
- [Front NS204i-u bracket spare part](#)
- [Storage controller spare parts](#)
- [HPE NS204i-u Boot Device V2 spare parts](#)
- [System Insight Display spare parts](#)
- [Front DisplayPort / USB spare parts](#)
- [Optical drive cable spare part](#)
- [OCP enablement cable spare parts](#)
- [Front OCP NIC cable spare part](#)
- [Front OCP NIC carrier spare part](#)
- [PHY board spare part](#)
- [OCP NIC interposer and cable spare parts](#)

Drive cage spare parts

Customer self repair: 4 E3.S stacked cage is **Mandatory**; 2 SFF stacked cage is **Optional**.

Replacement procedures:

- [Removing and replacing the stacked 2 SFF drive cage](#)
- [Removing and replacing the stacked 4 E3.S drive cage](#)

Description	Spare part number
2 SFF stacked drive cage *	P80075-001
4 E3.S stacked drive cage *	P76288-001

*This cage is supported in the 10 SFF / 20 E3.S server or servers using the mixed drive type configuration.

Drive backplane spare parts

Customer self repair: P40444-001 and P39783-001 are **Mandatory**. The remaining parts are **Optional**.

Replacement procedures:

- [Removing and replacing the 4 LFF drive backplane](#)
- [Removing and replacing the 8 SFF drive backplane](#)
- [Removing and replacing the 2 SFF drive backplane in the 8 + 2 SFF drive configuration](#)
- [Removing and replacing the stacked 2 SFF / 4 E3.S drive backplane in the 10 SFF / 20 E3.S server](#)

Description	Spare part number
4 LFF drive configuration	—
4 LFF 12G x1 SAS UBM6 LP	P62075-001
8 + 2 SFF drive configuration	—
8 SFF 24G x1 U.3 NVMe/SAS UBM3	P40444-001
8 SFF 24G x1 NVMe/SAS UBM6 BC	P62072-001
2 SFF 24G x4 NVMe/SAS UBM3 BC	P39783-001
2 SFF 24G x4 U.3 NVMe UBM6 BC	P62071-001
10 SFF / 20 E3.S / mixed drive type configuration	—
2 SFF 24G x4 NVMe/SAS UBM10	P73069-001
4 E3.S 32G x4 NVMe UBM10	P73067-001

Chassis intrusion detection switch spare part

Customer self repair: **Mandatory**

Replacement procedure: [Removing and replacing the chassis intrusion detection switch](#)

Description	Spare part number
Chassis intrusion detection switch	P52442-001

PCIe riser board spare parts

Customer self repair: **Mandatory**

Replacement procedure: [Removing and replacing a primary riser board](#)

Description	Spare part number
1U 1 x16 low-profile riser	P56498-001
1U 2 x16 butterfly riser	P56497-001

Front NS204i-u bracket spare part

Customer self repair: **Mandatory**

Replacement procedure: [Removing and replacing the boot device cage](#)

Description	Spare part number
Front NS204i-u bracket	P81214-001

For boot device spares, see [HPE NS204i-u Boot Device V2 spare parts](#).

Storage controller spare parts

Customer self repair: **Optional**

Replacement procedures:

- [Removing and replacing a type-o storage controller](#)
- [Removing and replacing a type-p storage controller](#)

Description	Spare part number
HPE MR932i-p PCIe SPDM Plug-in Storage Controller	P75933-001
HPE Gen11 type-p controllers	—
HPE MR416i-p Gen11 x16 Lanes 8GB Cache PCI SPDM Plug-in Storage Controller	P47951-001
HPE MR216i-p Gen11 x16 Lanes without Cache PCI SPDM Plug-in Storage Controller	P47953-001
HPE Gen11 type-o controllers	—
HPE MR416i-o Gen11 x16 Lanes 8GB Cache OCP SPDM Storage Controller	P47952-001

Description	Spare part number
HPE MR216i-o Gen11 x16 Lanes without Cache OCP SPDM Storage Controller	P47954-001
HPE MR408i-o Gen11 x8 Lanes 4GB Cache OCP SPDM Storage Controller	P58543-001
HPE Gen10 type-p controller	—
HPE Smart Array E208e-p SR Gen10 Controller	836267-001

HPE NS204i-u Boot Device V2 spare parts

Customer self repair: Cage, carrier, and SSD are **Optional**; cables are **Mandatory**

Replacement procedure: [Removing and replacing the boot device cage](#)



IMPORTANT

For successful RAID 1 configuration, verify that the boot device SSDs have the same model number and firmware version:

- In the iLO web interface, see the **Storage** page.
- In UEFI System Utilities, see **System Configuration > HPE NS204i Boot Controller > Physical Device Information**.

Configurations with SSDs from different manufacturers are not supported.

NS204i-u

Description	Spare part number
Boot device V2 cage	P78425-001
M.2 SSD carrier	P59777-001
960 GB NVMe RI M.2 2280 V2 MV SSD	P80343-001
960 GB NVMe RI M.2 2280 MV SED SSD	P80345-001
480 GB NVMe RI M.2 2280 V2 MV SSD	P80342-001
480 GB NVMe RI M.2 SV 2280 SSD	P69616-001

Cables

Cable description and part number	Spare part number
Front / internal HPE NS204i-u Boot Device V2 power cable: P48956-001	P56479-001

Cable description and part number	Spare part number
Front / internal HPE NS204i-u Boot Device V2 signal cable: P74839-001	P76017-001
Riser cage HPE NS204i-u Boot Device V2 signal cable: P71913-001	P74376-001

System Insight Display spare parts

Customer self repair: **Mandatory**

Replacement procedure: Removing and replacing the System Insight Display

Description	Spare part number
System Insight Display	P79637-001
System Insight Display cable: P48971-001	P58227-001

Front DisplayPort / USB spare parts

Customer self repair: **Mandatory**

Replacement procedures:

- Removing and replacing the optical drive / DisplayPort / USB in the 4 LFF server
- Removing and replacing the DisplayPort / USB / optical drive in the 8 SFF server
- Removing and replacing a DisplayPort / USB / optical drive in drive boxes 4–5

Cable description and part number	Spare part number
4 LFF DisplayPort / USB enablement kit, includes the following: <ul style="list-style-type: none"> • DisplayPort / USB tray • Front DisplayPort and USB cable: P73948-001 	P79731-001
Front DisplayPort and USB cable: P73948-001 *	P76976-001
Front I/O cable: P71909-002 *	P77132-001

* This cable is supported in all the available drive configurations.

Optical drive cable spare part

Customer self repair: **Mandatory**

Cable description and part number	Spare part number
Optical drive cable: P73776-002	P76888-001

OCP enablement cable spare parts

Customer self repair: **Mandatory**

Cable description and part number	Spare part number
CPU1 to Slot 15 OCP B x8 enablement cable: P74889-001	P76891-001
CPU1 to Slot 14 OCP A x16 enablement cable: P74890-001	P76892-001
CPU2 to Slot 15 OCP B x8 / x16 enablement cable: P74891-001	P76893-001

Front OCP NIC cable spare part

The front OCP NIC hardware options and spare parts are supported in the 10 SFF / 20 E3.S server.

Customer self repair: **Mandatory**

Replacement procedure: Removing and replacing the front OCP NIC cable

Cable description and part number	Spare part number
Primary / secondary front OCP NIC cable: P71942-001	P76977-001

Front OCP NIC carrier spare part

The front OCP NIC hardware options and spare parts are supported in the 10 SFF / 20 E3.S server.

Customer self repair: **Mandatory**

Replacement procedure: Removing and replacing a front OCP NIC or carrier kit

Description	Spare part number
Front OCP NIC carrier kit, includes: <ul style="list-style-type: none">• OCP NIC carrier• OCP NIC bracket	P79872-001

PHY board spare part

The front OCP NIC hardware options and spare parts are supported in the 10 SFF / 20 E3.S server.

Customer self repair: **Mandatory**

Replacement procedure:

Description	Spare part number
PHY board	P76348-001

Safety considerations

Before performing service procedures, review all the safety information.

- Electrostatic discharge
- Symbols on equipment
- Rack warnings and cautions
- Server warnings and cautions

Subtopics

Electrostatic discharge

Symbols on equipment

Rack warnings and cautions

Server warnings and cautions

Electrostatic discharge

Be aware of the precautions you must follow when setting up the system or handling components. A discharge of static electricity from a finger or other conductor may damage system boards or other static-sensitive devices. This type of damage may reduce the life expectancy of the system or component.

To prevent electrostatic damage:

- Avoid hand contact by transporting and storing products in static-safe containers.
- Keep electrostatic-sensitive parts in their containers until they arrive at static-free workstations.
- Place parts on a grounded surface before removing them from their containers.
- Avoid touching pins, leads, or circuitry.
- Always be properly grounded when touching a static-sensitive component or assembly. Use one or more of the following methods when handling or installing electrostatic-sensitive parts:
 - Use a wrist strap connected by a ground cord to a grounded workstation or computer chassis. Wrist straps are flexible straps with a minimum of 1 megohm \pm 10 percent resistance in the ground cords. To provide proper ground, wear the strap snug against the skin.
 - Use heel straps, toe straps, or boot straps at standing workstations. Wear the straps on both feet when standing on conductive floors or dissipating floor mats.
 - Use conductive field service tools.
 - Use a portable field service kit with a folding static-dissipating work mat.

If you do not have any of the suggested equipment for proper grounding, have an authorized reseller install the part.

For more information on static electricity or assistance with product installation, contact an authorized reseller.

Symbols on equipment

The following symbols may be placed on equipment to indicate the presence of potentially hazardous conditions:



This symbol in conjunction with any of the following symbols indicates the presence of a potential hazard. The potential for injury exists if warnings are not observed. Consult your documentation for specific details.

該符號與以下任意符號組合使用，指示存在潛在的危險。如果不遵守警告，可能會造成人身傷害。詳細信息請參閱相關文檔。



This symbol indicates the presence of hazardous energy circuits or electric shock hazards. Refer all servicing to qualified personnel.



WARNING

To reduce the risk of injury from electric shock hazards, do not open this enclosure. Refer all maintenance, upgrades, and servicing to qualified personnel.

此符號表明存在危險電路或觸電的危險。所有維修工作應由具有相關資格的人員來完成。

警告：為了減少觸電造成人身傷害的危險，請不要打開此外殼。所有維護、升級和維修工作都應由具有相關資格的人員來完成。



This symbol indicates the presence of electric shock hazards. The area contains no user or field-serviceable parts. Do not open for any reason.



WARNING

To reduce risk of injury from electric shock hazards, do not open this enclosure.



This symbol on an RJ-45 receptacle indicates a Network Interface Connection.



WARNING

To reduce risk of electric shock, fire, or damage to the equipment, do not plug telephone or telecommunications connectors into this receptacle.

RJ-45 插孔上的該符號指示網絡接口連接。

警告：為了減少觸電、火災或設備損壞的危險，不要將電話或電信連接設備插入此插孔。



This symbol indicates the presence of a hot surface or hot component. If this surface is contacted, the potential for injury exists.



WARNING

To reduce the risk of injury from a hot component, allow the surface to cool before touching.

此符號表明表面或組件過熱。如果觸摸此表面，可能會造成人身傷害。警告：為了減少因組件過熱而造成人身傷害的危險，應等到表面降溫後再觸摸。



This symbol indicates the presence of a moving fan blade. If the spinning blades are contacted, the potential for injury exists.



WARNING

Hazardous moving parts. Keep away from moving fan blades. To reduce the risk of injury from a hot component, allow the surface to cool before touching.

此符號表明存在運動風扇葉片的危險。如果觸摸旋轉葉片，可能會造成人身傷害。警告：危險的運動部件。請遠離運動風扇刀片。為減少被高溫組件燙傷的危險，應在表面冷卻之後再接觸。

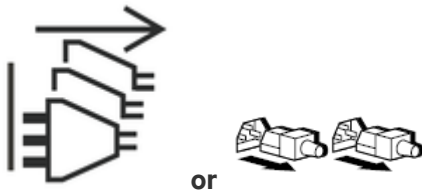

These symbols on power supplies or systems indicate that the equipment is supplied by multiple sources of power.



WARNING

To reduce the risk of injury from electric shock, remove all power cords to completely disconnect power from the system.

電源或系統上的這些符號表明設備由多個電源供電。
警告：為了減少觸電造成人身傷害的危險，應拔下所有電源線插頭，完全斷開系統的電源。



Weight in kg.

Weight in lb.

This symbol indicates that the component exceeds the recommended weight for one individual to handle safely.



WARNING

To reduce the risk of personal injury or damage to the equipment, observe local occupational health and safety requirements and guidelines for manual material handling.

此符號表明組件的重量超出了建議值，一個人無法安全取放。
警告：為了減少人身傷害或設備損壞的危險，應遵守當地有關人工取放物品的職業保健與安全規定及準則。



A discharge of static electricity from a finger or other conductor may damage system boards or other static-sensitive devices. To prevent damage, observe antistatic precautions.



These symbols appearing together indicate that the product may have high touch current and that a reliable earth ground must be in place before connecting the equipment.



WARNING

Risk of electric shock due to high touch current. Connect to earth before connecting to supply.



This symbol indicates the presence of a laser device in the product that may exceed Class 1 limits. Refer to the product documentation for more information.

此符號表明在可能會超出 1 類限制的產品中存在激光設備。有關詳細信息，請參閱產品文檔。



This symbol indicates the presence of moving parts inside the product that may present a pinch point if improperly contacted.



WARNING

Hazardous moving parts. Do not insert any tools or any part of your body into the product while it is operating or in any openings.



This symbol indicates the presence of coin cell battery.



WARNING

- **INGESTION HAZARD:** This product contains a button cell or coin battery.
- **DEATH** or serious injury can occur if ingested.
- A swallowed button cell or coin battery can cause Internal Chemical Burns in as little as 2 hours.
- **KEEP** new and used batteries **OUT OF REACH** of **CHILDREN**.
- Seek immediate medical attention if a battery is suspected to be swallowed or inserted inside any part of the body.

Rack warnings and cautions



WARNING

When all components are removed, the server weighs 14.87 kg (32.71 lb). When all components are installed, the server can weigh up to 21.38 kg (47.04 lb).

Before configuring your rack solution, be sure to check the rack manufacturer weight limits and specifications. Failure to do so can result in physical injury or damage to the equipment and the facility.



WARNING

The server is heavy. To reduce the risk of personal injury or damage to the equipment, do the following:

- Observe local occupational health and safety requirements and guidelines for manual material handling.
- Get help to lift and stabilize the product during installation or removal, especially when the product is not fastened to the rails. The server weighs more than 14.87 kg (32.71 lb), so at least two people must lift the server into the rack together. An additional person may be required to help align the server if the server is installed higher than chest level.
- Use caution when installing the server in or removing the server from the rack.
- Adequately stabilize the rack before extending a component outside the rack. Extend only one component at a time. A rack may become unstable if more than one component is extended.
- Do not stack anything on top of rail-mounted component or use it as a work surface when extended from the rack.



WARNING

To reduce the risk of personal injury or damage to the equipment, be sure that:

- The rack has anti-tip measures in place. Such measures include floor-bolting, anti-tip feet, ballast, or a combination as specified by the rack manufacturer and applicable codes.
- The leveling jacks (feet) are extended to the floor.
- The full weight of the rack rests on the leveling jacks (feet).

Server warnings and cautions



WARNING

To reduce the risk of personal injury, electric shock, or damage to the equipment, disconnect the power cord to remove power from the server. Pressing the Power On/Standby button does not shut off system power completely. Portions of the power supply and some internal circuitry remain active until AC power is removed.



WARNING

To reduce the risk of personal injury from hot surfaces, allow the drives and the internal system components to cool before touching them.



WARNING

To reduce the risk of fire or burns after removing the energy pack:

- Do not disassemble, crush, or puncture the energy pack.
- Do not short external contacts.
- Do not dispose of the energy pack in fire or water.
- Do not expose the energy pack to low air pressure as it might lead to explosion or leakage of flammable liquid or gas.
- Do not expose the energy pack to temperatures higher than 60°C (140°F).

After power is disconnected, battery voltage might still be present for 1s to 160s.



CAUTION

Protect the server from power fluctuations and temporary interruptions with a regulating UPS. This device protects the hardware from damage caused by power surges and voltage spikes and keeps the server in operation during a power failure.



CAUTION

To prevent damage to electrical components, properly ground the server before beginning any installation, removal, or replacement procedure. Improper grounding can cause electrostatic discharge.



CAUTION

To avoid data loss, Hewlett Packard Enterprise recommends that you back up

Preparation procedures

Prerequisites

Before powering down the server for an upgrade, maintenance, or service procedure, perform a backup of critical server data.

About this task

To access components and perform certain upgrade, maintenance, or service procedure, you must perform one or more of the procedures described in this section.

Subtopics

Server data backup

Power down the server

Extend the server from the rack

Release the cable management arm

Remove the server from the rack

Remove the access panel

Remove the air baffle

Remove the middle cover

Remove the fan wall

Remove the primary PCIe riser cage

Power up the server

Server data backup

To avoid data loss, make sure to back up all server data before installing or removing a hardware option, performing a server maintenance, or a troubleshooting procedure.

Server data in this context refers to information that may be required to return the system to a normal operating environment after completing a hardware maintenance or troubleshooting procedure. This information may include:

- User data files
- User account names and passwords
- Application settings and passwords
- Component drivers and firmware
- TPM recovery key/password

- BIOS configuration settings—Use the backup and restore function in UEFI System Utilities. For more information, see the UEFI user guide (<https://www.hpe.com/support/hpeuefisystemutilities-quicklinks>).
 - Custom default system settings
 - Security passwords including those required for power-on and BIOS admin access, persistent memory, and Server Configuration Lock (for HPE Trusted Supply Chain servers)
 - Server serial number and the product ID
- iLO-related data—Use the iLO backup and restore function. For more information, see the iLO user guide (<https://www.hpe.com/support/hpeilodocs-quicklinks>).
 - iLO license
 - Customer iLO user name, password, and DNS name
 - iLO configuration settings

Power down the server

Before powering down the server for any upgrade or maintenance procedures, perform a backup of critical server data and programs.



IMPORTANT

When the server is in standby mode, auxiliary power is still being provided to the system.

To power down the server, use one of the following methods:

- Press and release the Power On/Standby button.
This method activates a controlled shutdown of applications and the OS before the server enters standby mode. It can also activate a shutdown behavior governed by an OS configuration or policy.
- Press and hold the Power On/Standby button for more than 4 seconds to force the server to enter standby mode.
This method forces the server to enter standby mode without properly exiting applications and the OS. If an application stops responding, you can use this method to force a shutdown.
- Use a virtual power button selection through iLO 7.
This method initiates a controlled remote shutdown of applications and the OS before the server enters standby mode.

Before proceeding, verify that the server is in standby mode by observing that the system power LED is amber.

Extend the server from the rack

Prerequisites

- You might need a T-25 Torx screwdriver to loosen the shipping screws.
- Review the:
 - [Rack warnings and cautions](#)
 - [Server warnings and cautions](#)

Procedure

Extend the server from the rack.



WARNING

To reduce the risk of personal injury or equipment damage, be sure that the rack is adequately stabilized before extending anything from the rack.

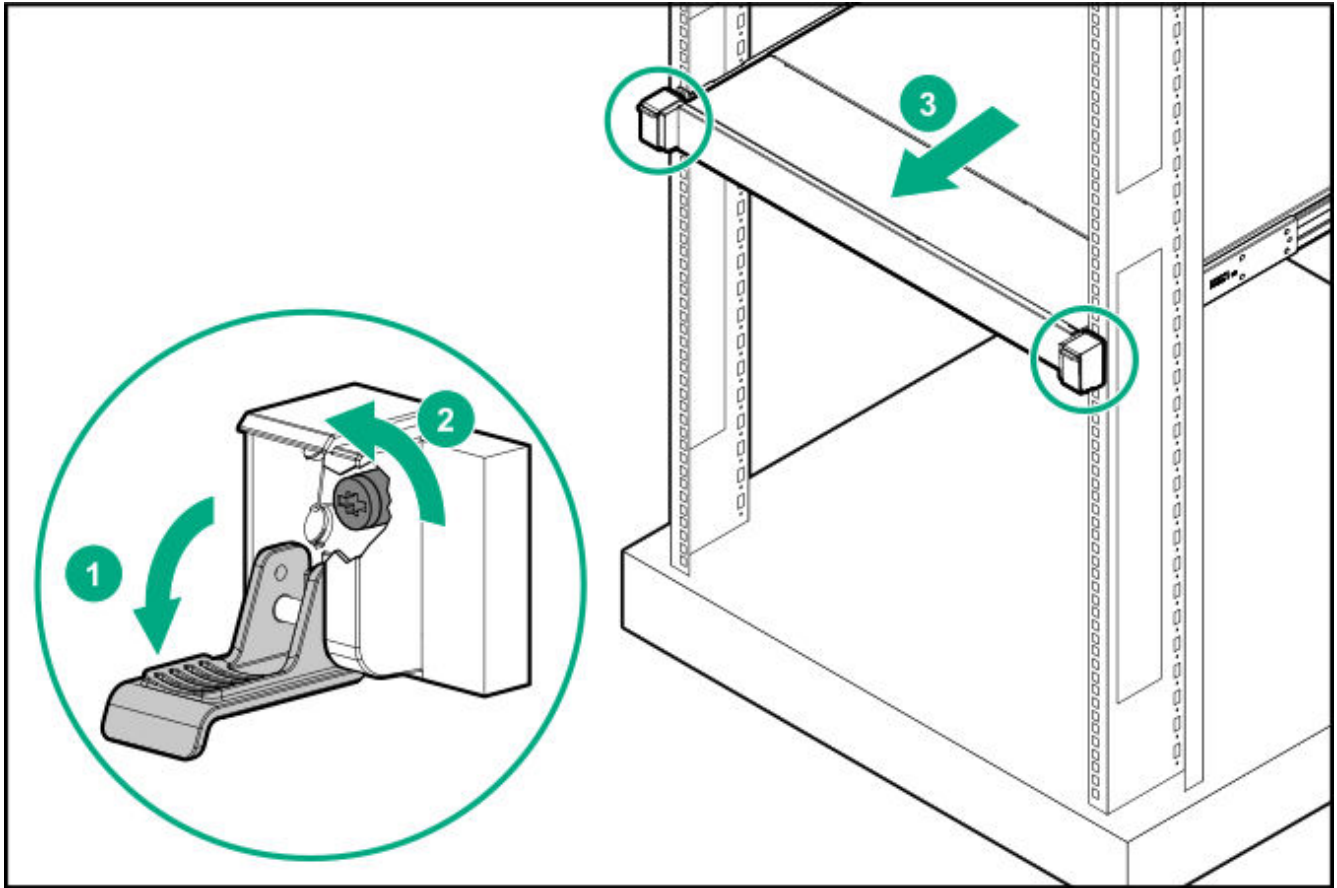

Release the cable management arm

About this task



CAUTION

To reduce the risk of personal injury, be careful when pressing the cable management or rail-release latches. The rails or latches could pinch your fingers.

Procedure

Release the cable management arm and swing away from the rack.

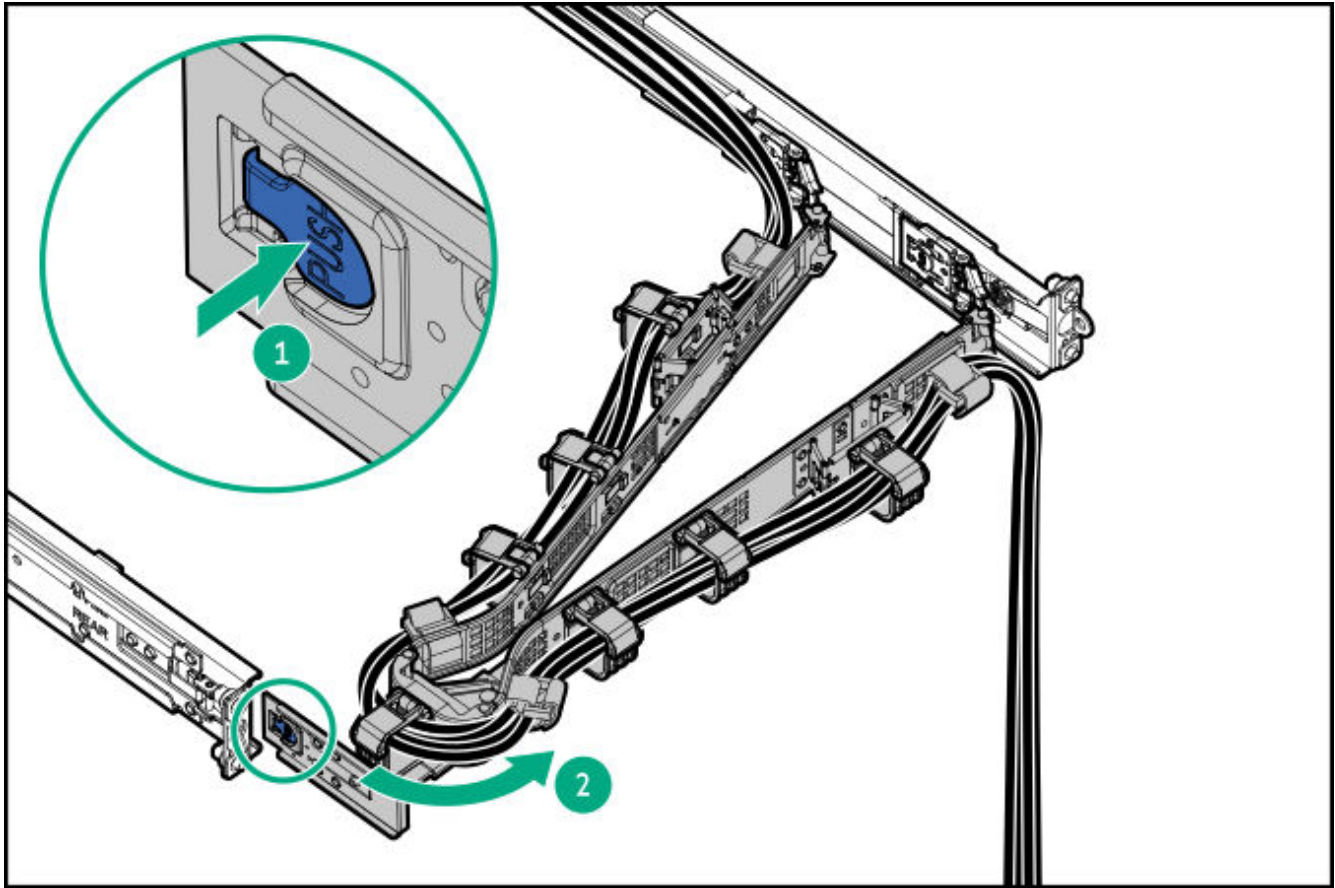

Remove the server from the rack

Prerequisites

Before you perform this procedure, review the:

- [Rack warnings and cautions](#)
- [Server warnings and cautions](#)

About this task



WARNING

To reduce the risk of personal injury or equipment damage, be sure that the rack is adequately stabilized before extending anything from the rack.

Procedure

1. [Power down the server.](#)

2. Release the cable management arm.
3. Disconnect the cabling from the rear panel.
4. Extend the server from the rack.
5. Remove the server from the rack:

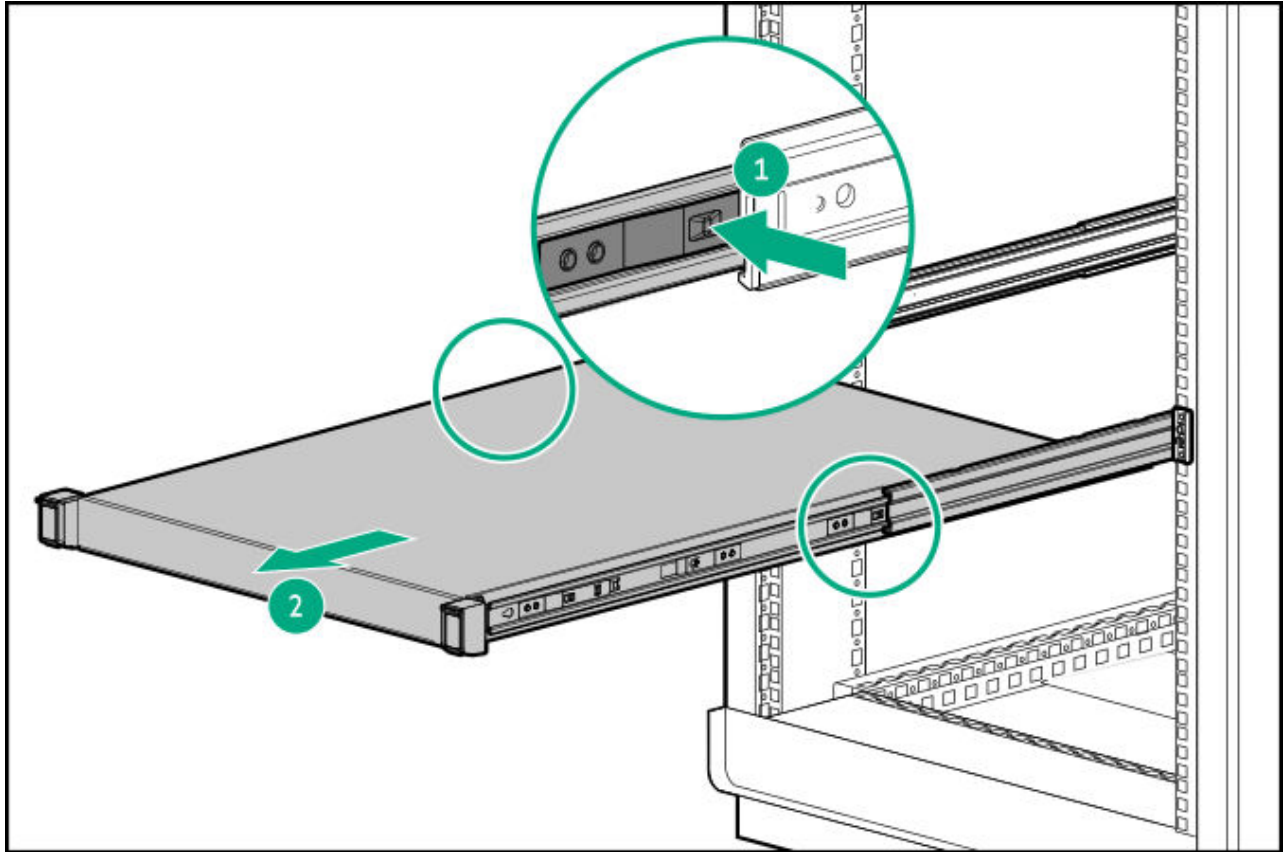

6. Place the server on a sturdy, level surface.

Remove the access panel

About this task



WARNING

To reduce the risk of personal injury from hot surfaces, allow the drives and the internal system components to cool before touching them.



CAUTION

Do not operate the server for long periods with the access panel open or removed. Operating the server in this manner results in improper airflow and improper cooling that can lead to thermal damage.

Procedure

1. Power down the server.
2. Extend the server from the rack.
3. Open or unlock the locking latch, slide the access panel to the rear of the chassis, and remove the access panel.

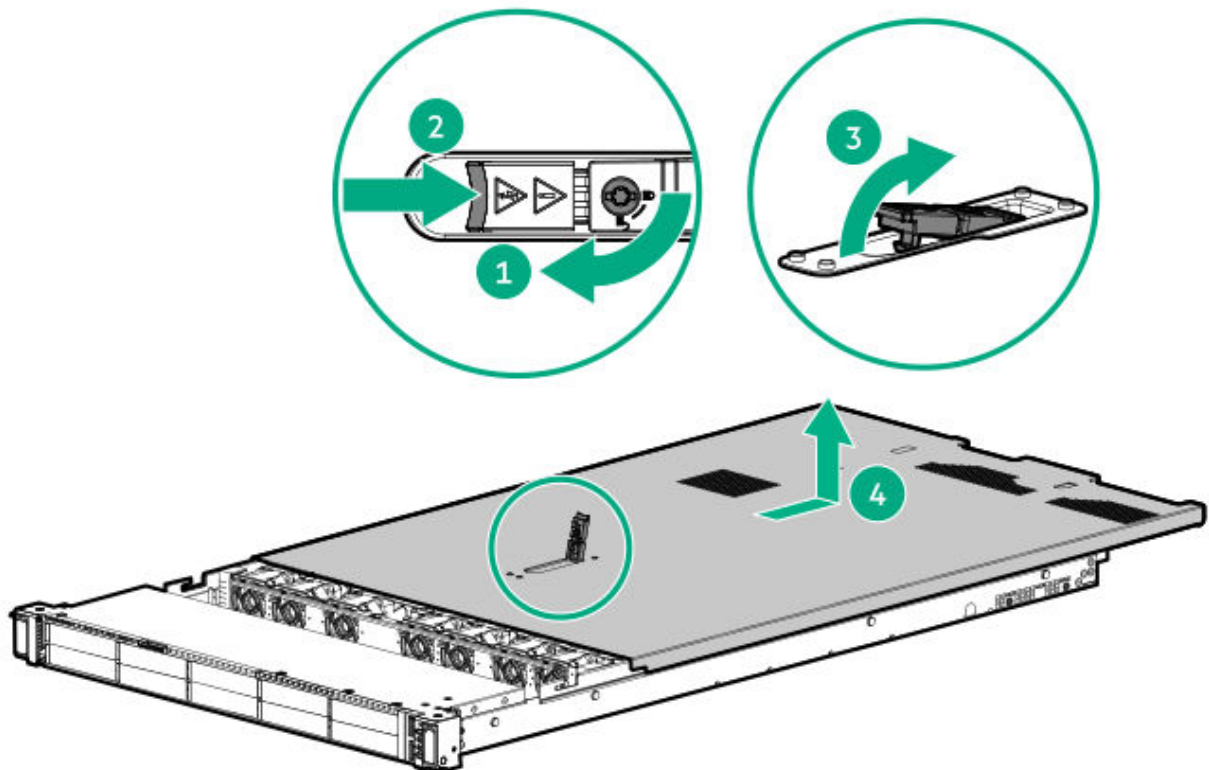

Remove the middle cover

About this task

The middle cover is available on the 10 SFF / 20 E3.S server.

https://sketchfab.com/models/acc000f01f31433bb44af7e1ecddf444/embed?ui_infos=0&ui_watermark=0&ui_help=0&ui_vr=0&ui_settings=0&ui_inspector=0&ui_hint=2&ui_color=01a982&ui_theme=dark&autostart=1&camera=0&



CAUTION

For proper cooling, do not operate the server without the access panel, baffles, expansion slot covers, or blanks installed.



CAUTION

To prevent damage to electrical components, properly ground the server before beginning any installation, removal, or replacement procedure. Improper grounding can cause electrostatic discharge.

Procedure

1. Power down the server.
2. Remove all power:
 - a. Disconnect each power cord from the power source.
 - b. Disconnect each power cord from the server.
3. Disconnect all peripheral cables from the server.
4. Extend the server from the rack.
5. Remove the access panel.
6. Take both sides of the middle cover and detach it from the server.

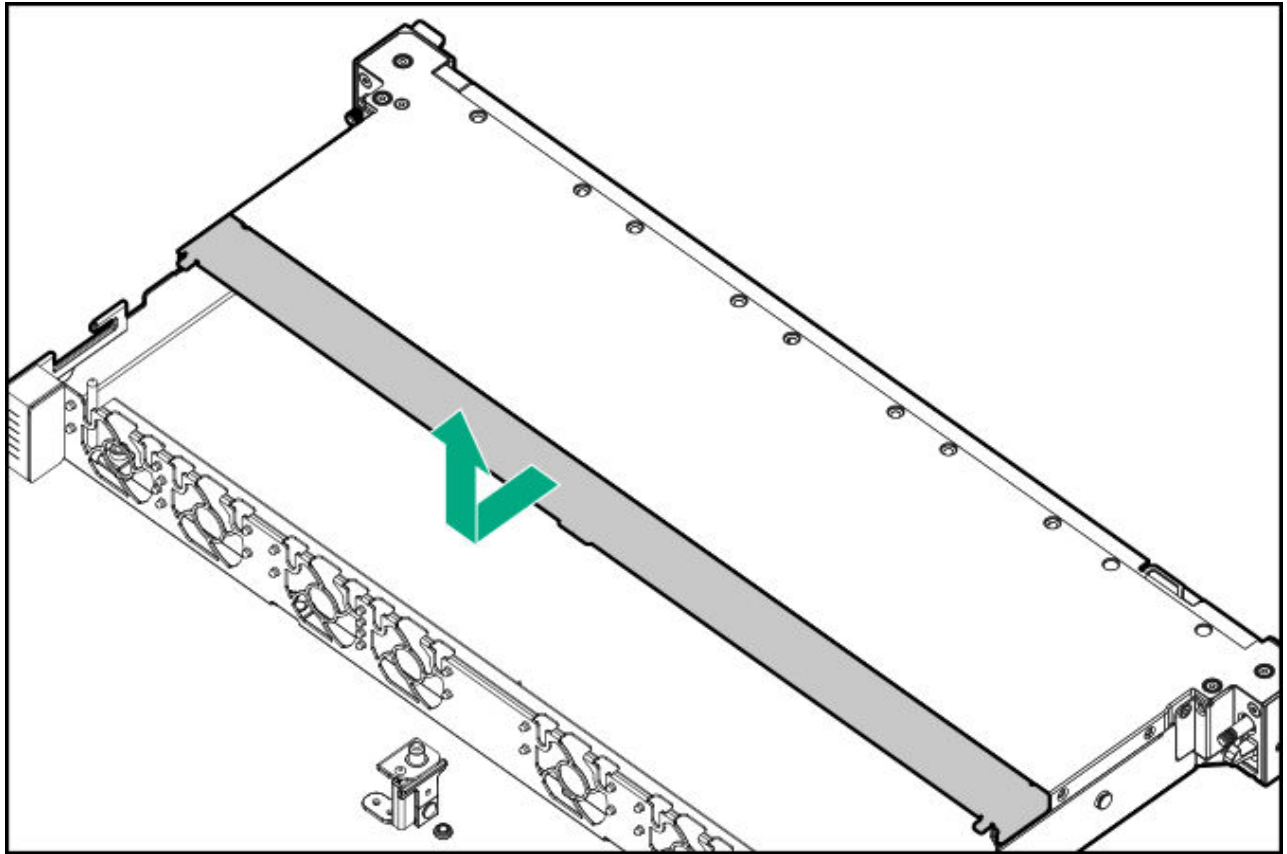

Remove the fan wall

Prerequisites

Before you perform this procedure, make sure that you have a T-15 Torx screwdriver available.

About this task

The fan wall is not available on servers with the liquid cooling heatsink and fan kit installed.



CAUTION

To prevent damage to electrical components, properly ground the server before beginning any installation, removal, or replacement procedure. Improper grounding can cause electrostatic discharge.

Procedure

1. Power down the server.
2. Remove all power:

- a. Disconnect each power cord from the power source.
- b. Disconnect each power cord from the server.
3. Disconnect all peripheral cables from the server.
4. Remove the server from the rack.
5. Place the server on a flat, level work surface.
6. Remove the access panel.
7. If installed, remove the air baffle.

An 8 SFF server is shown. The removal procedure is the same for all drive configurations.

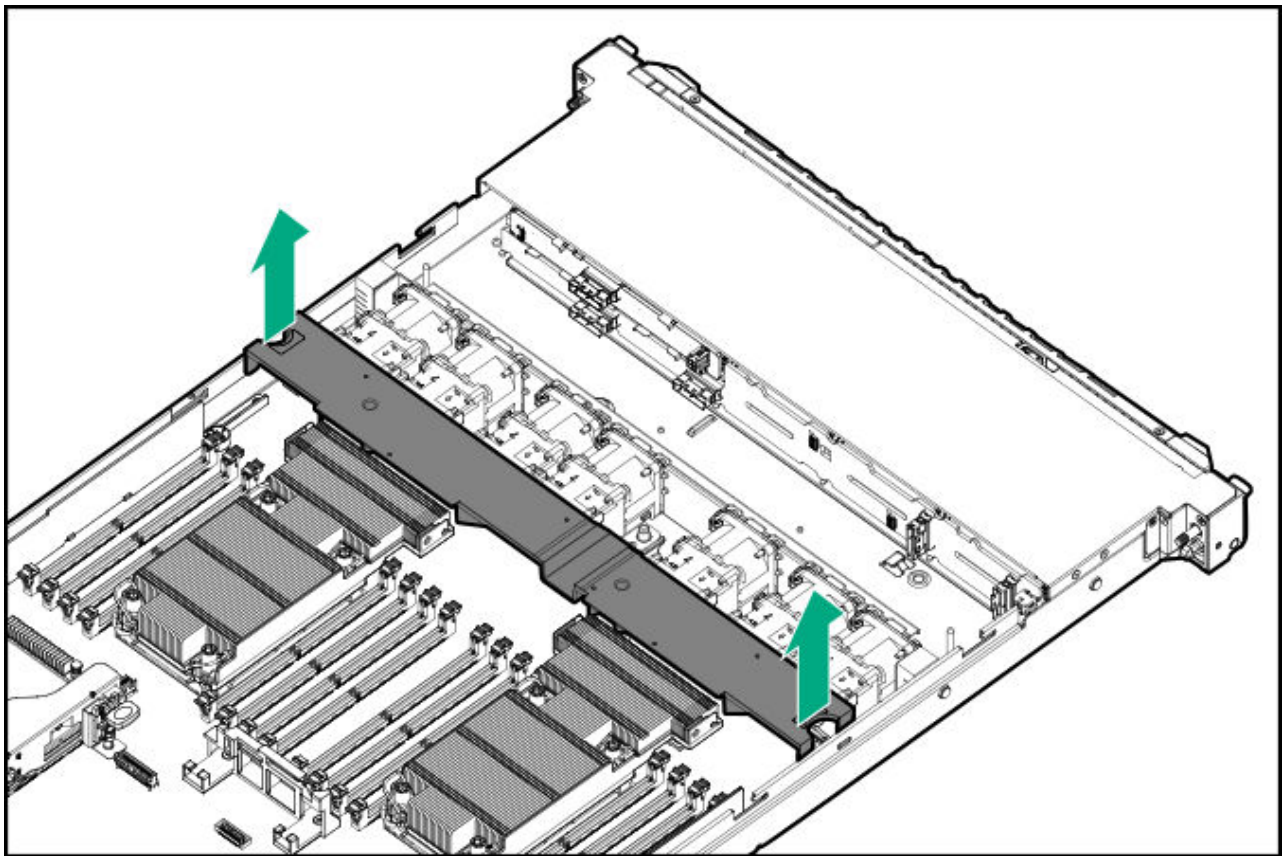

8. Remove the fans.

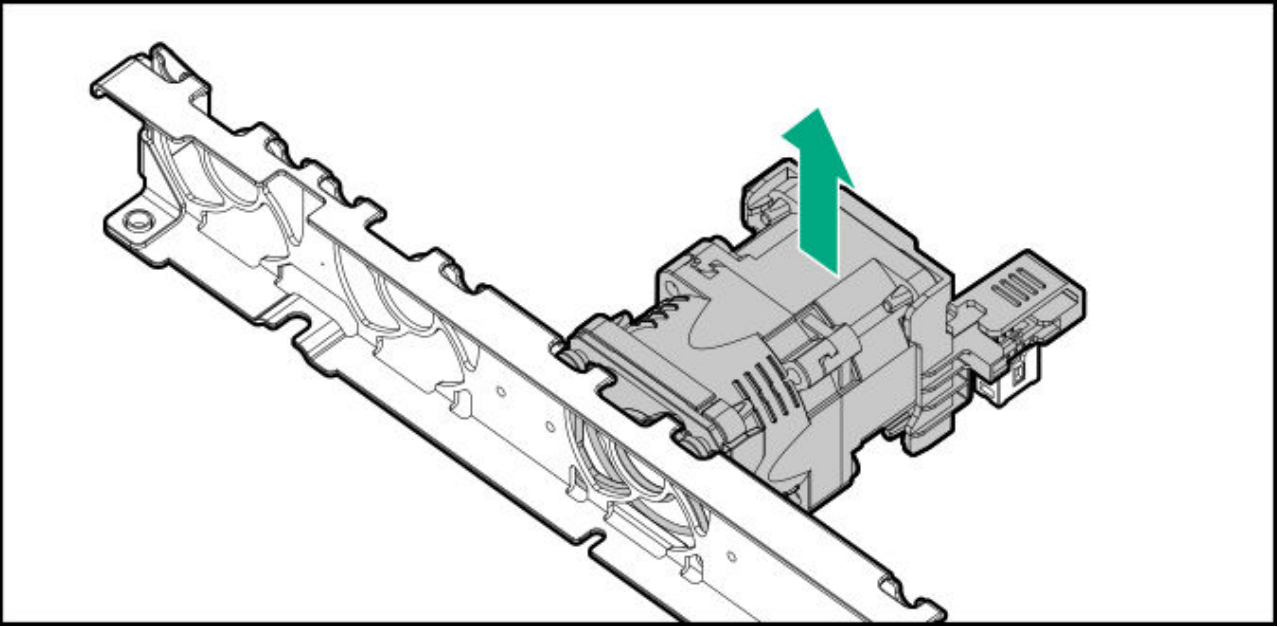

9. Remove the screws to remove the fan wall.

Retain the screws and fan wall. These screws will be used to secure the fan wall after replacing or installing the internal component.

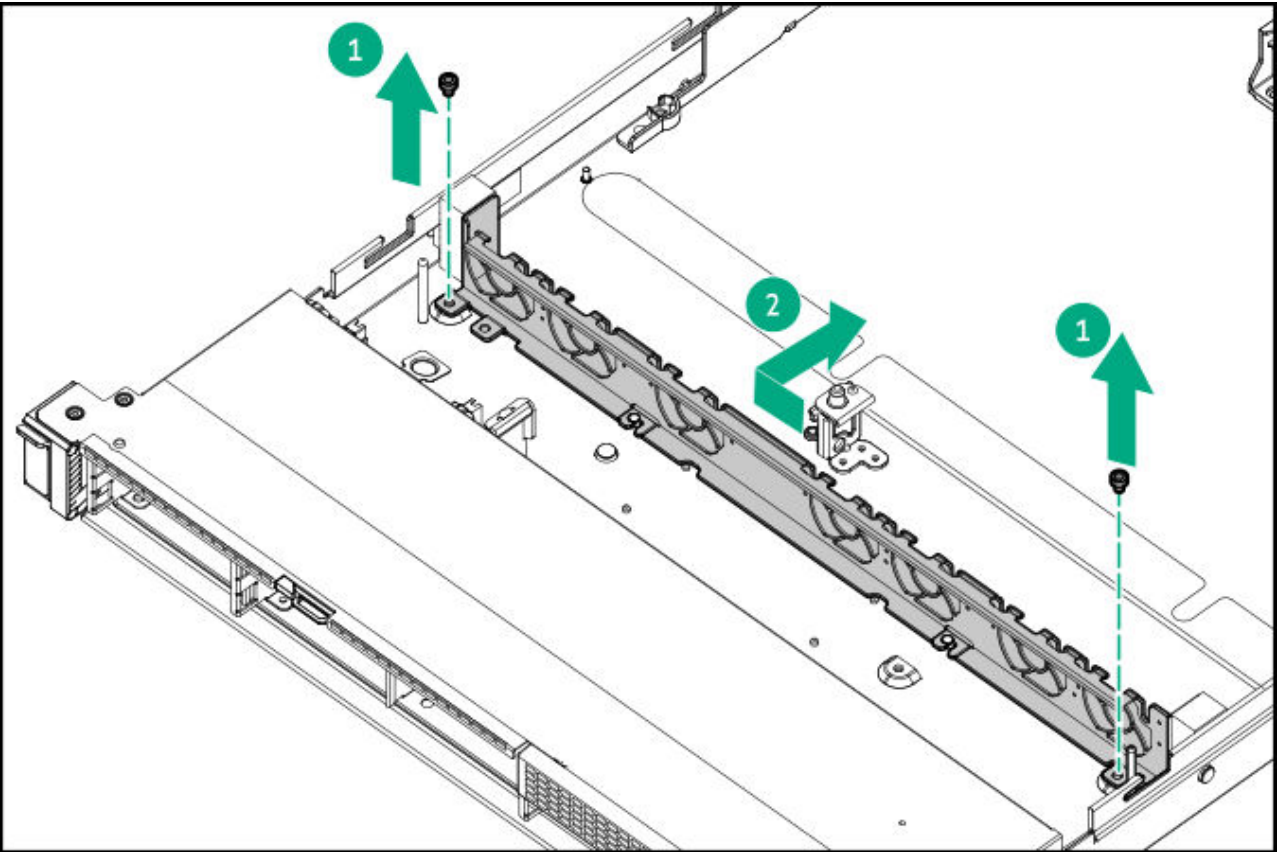

Remove the primary PCIe riser cage

About this task



WARNING

To reduce the risk of personal injury from hot surfaces, allow the drives and the internal system components to cool before touching them.



CAUTION

To prevent improper cooling and thermal damage, do not operate the server unless all bays are populated with either a component or a blank.



CAUTION

To prevent damage to electrical components, properly ground the server before beginning any installation, removal, or replacement procedure. Improper grounding can cause electrostatic discharge.

Procedure

1. Power down the server.
2. Remove all power:
 - a. Disconnect each power cord from the power source.
 - b. Disconnect each power cord from the server.
3. Do one of the following:
 - a. Extend the server from the rack.
 - b. Remove the server from the rack.
4. Remove the access panel.
5. Remove the secondary riser cage blank.
6. Remove the PCI riser cage.

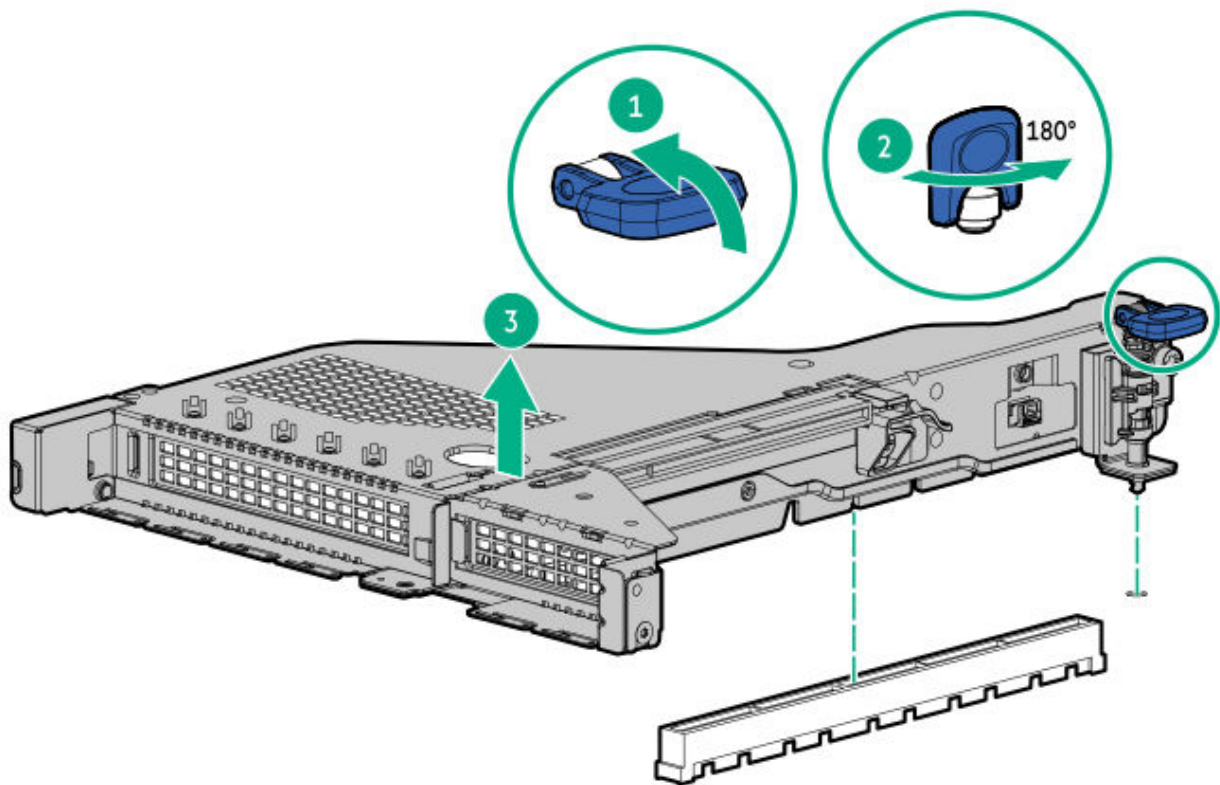

Power up the server

Procedure

- Press the Power On/Standby button.
- Use the virtual power button through iLO 7.

Removing and replacing the cable management arm

Prerequisites

For 1U servers that are densely populated in a deep rack, you must extend the server to access the release latch.

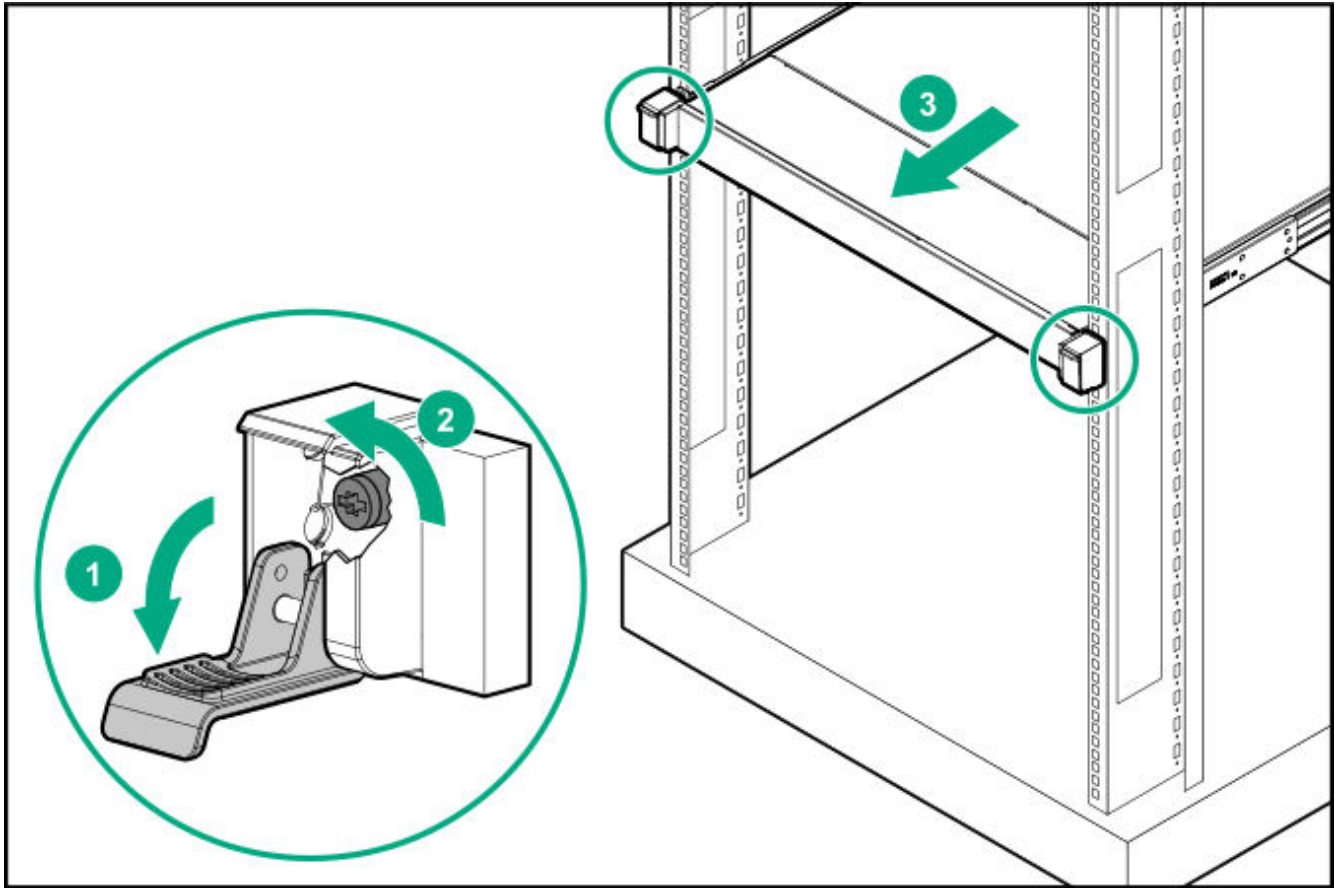

About this task



CAUTION

Support the CMA during the removal and replacement procedures. Do not allow the CMA to hang by its own weight during the procedure.



CAUTION

To reduce the risk of personal injury, be careful when pressing the cable management or rail-release latches. The rails or latches could pinch your fingers.

Procedure

1. Press the release latch and open the cable management arm.

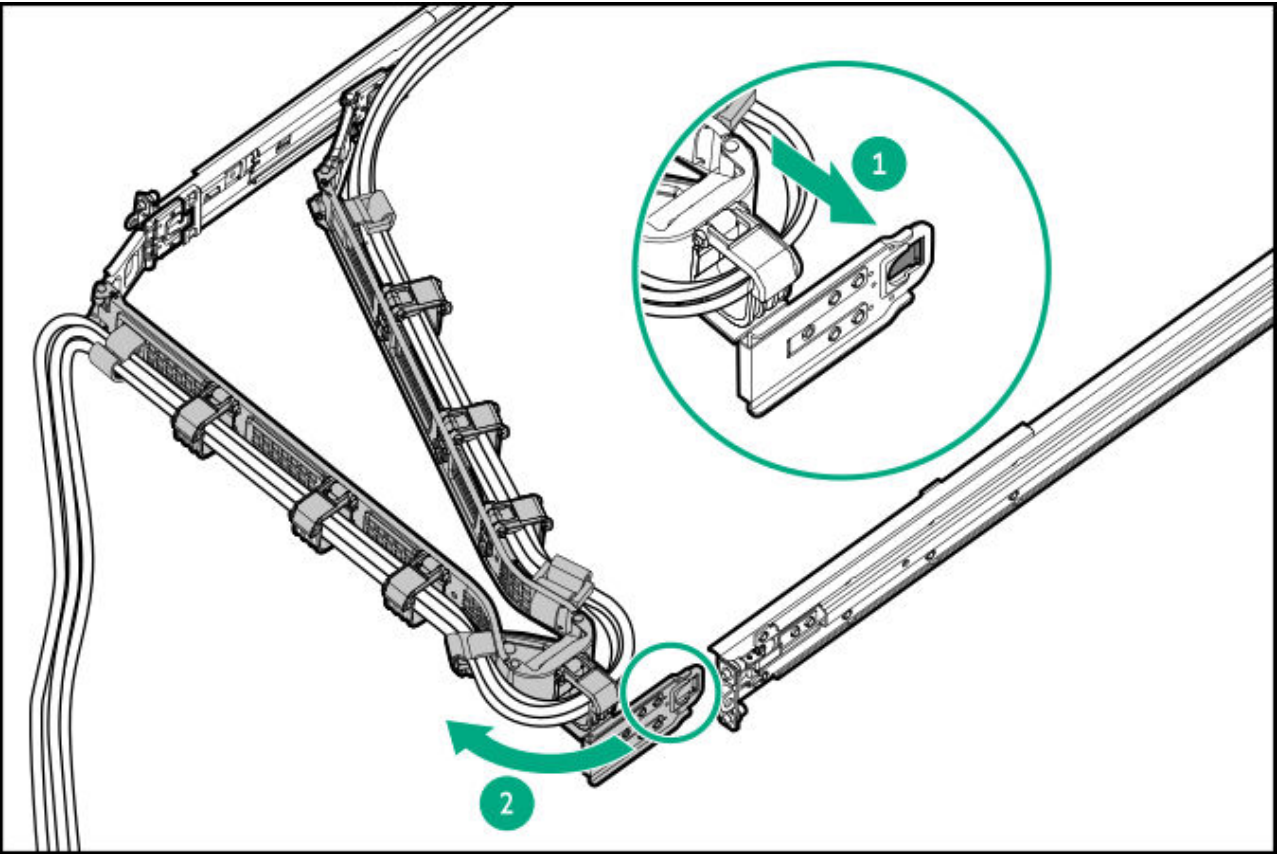

2. Open all cable baskets and loosen straps.

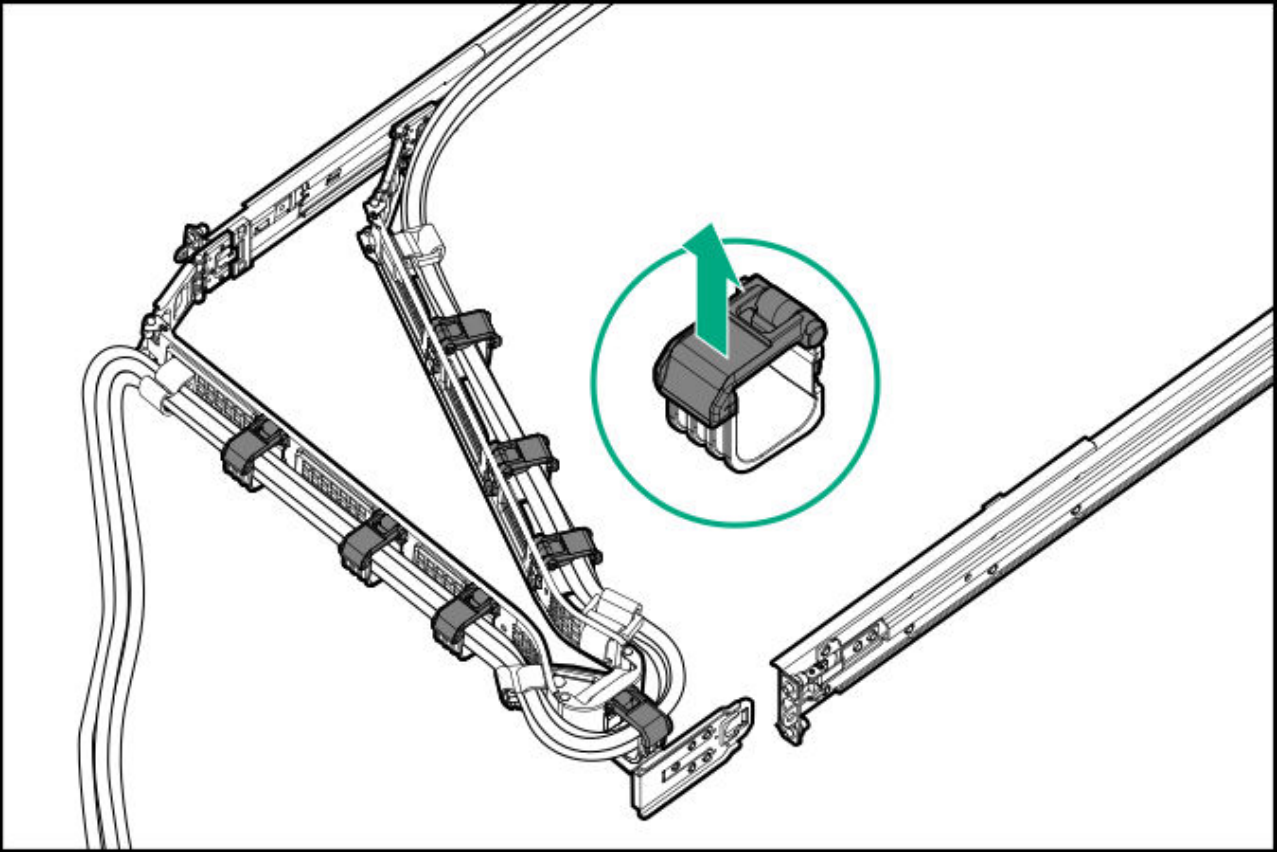

3. Remove the cables.

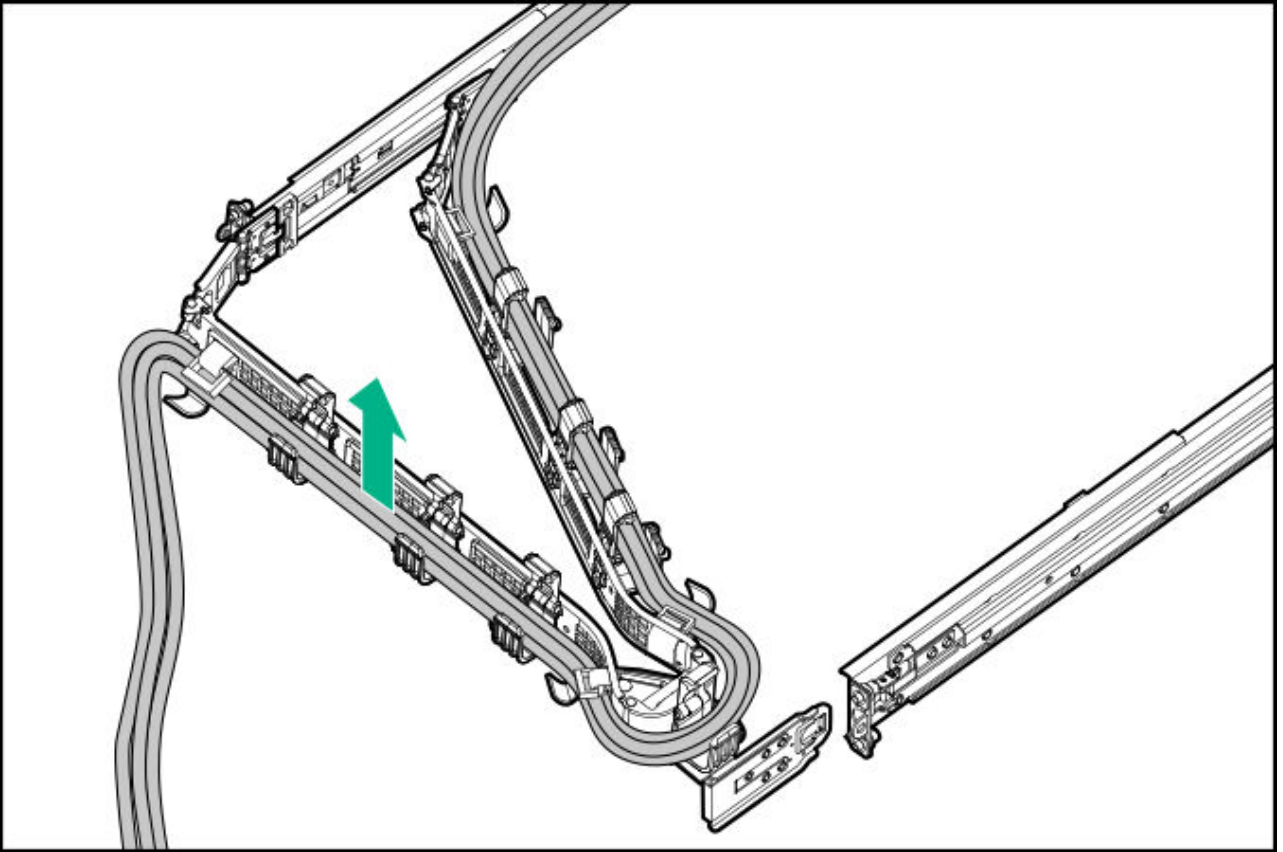

4. Remove the cable management arm.

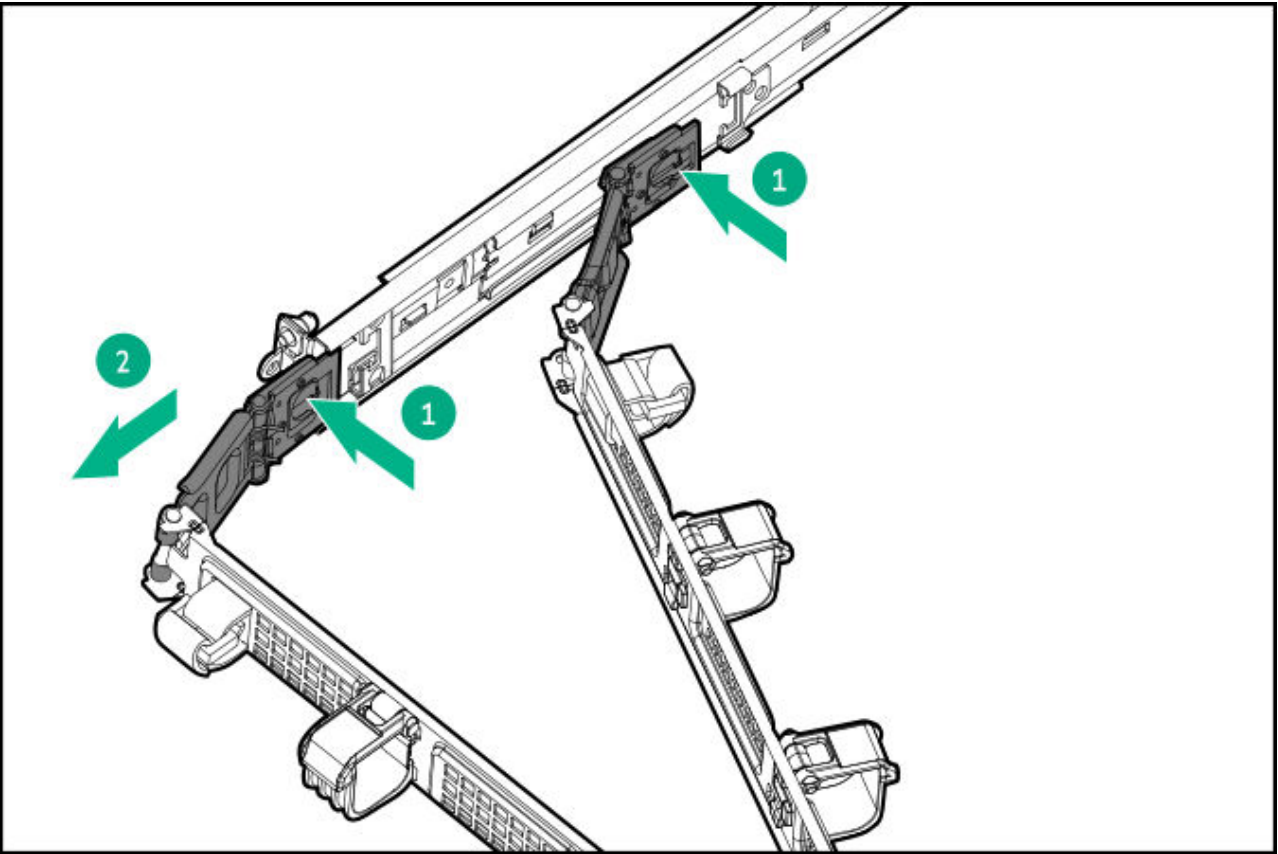

Results

The removal procedure is complete. To replace the component, reverse this procedure.

Rack rail replacement

Subtopics

Rack mounting interfaces

Removing and replacing the friction rack rails

Removing and replacing the friction rack rails

Prerequisites

- Review the [rack mounting interfaces](#).

- If you are replacing the rack mounting rails from a threaded-hole rack, make sure that you have a T-25 Torx screwdriver available.

About this task

https://sketchfab.com/models/7b55f5599368447a82781f373bcacc3d/embed?ui_infos=0&ui_watermark=0&ui_help=0&ui_vr=0&ui_settings=0&ui_inspector=0&ui_hint=2&ui_color=01a982&ui_theme=dark&autostart=1&camera=0

Procedure

1. Power down the server.
2. Remove all power:
 - a. Disconnect each power cord from the power source.
 - b. Disconnect each power cord from the server.
3. Disconnect all peripheral cables from the server.
4. Remove the server from the rack.
5. Place the server on a flat, level work surface.
6. If installed, remove the cable management arm.
7. To remove the sliding rails, do the following:
 - a. Pull and hold the release latch.
 - b. Slide the rail towards the front panel and pull it from the server.

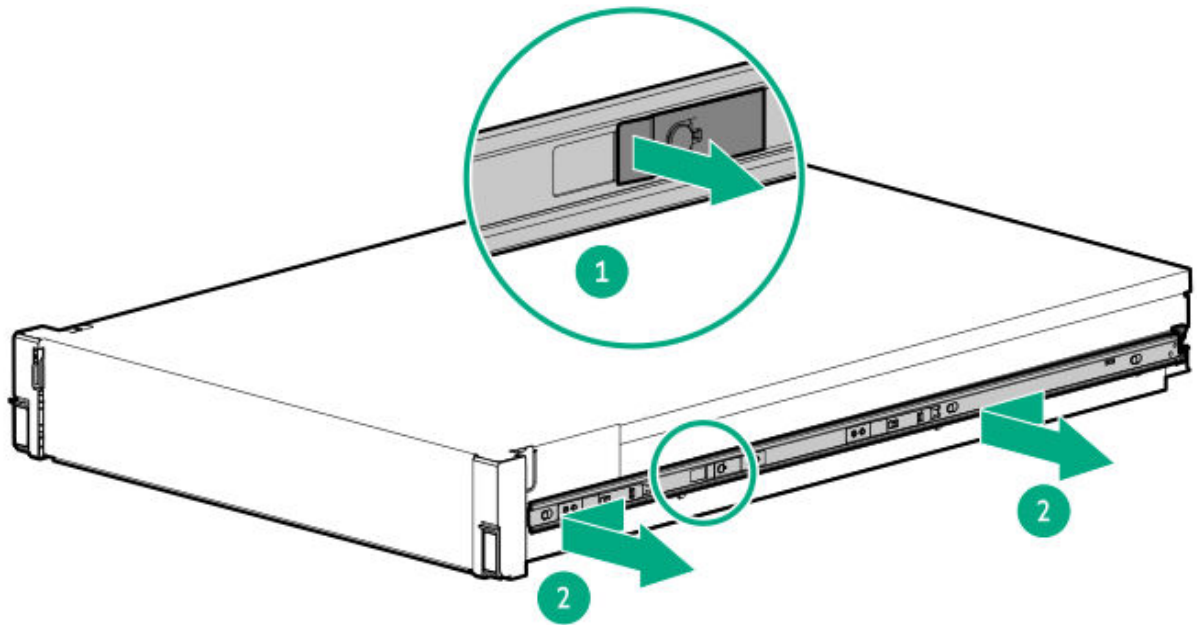

c. Repeat steps a and b to remove the other sliding rail.

8. To remove the rack mounting rails, do the following:

a. In a threaded-hole rack, remove the rail screws.

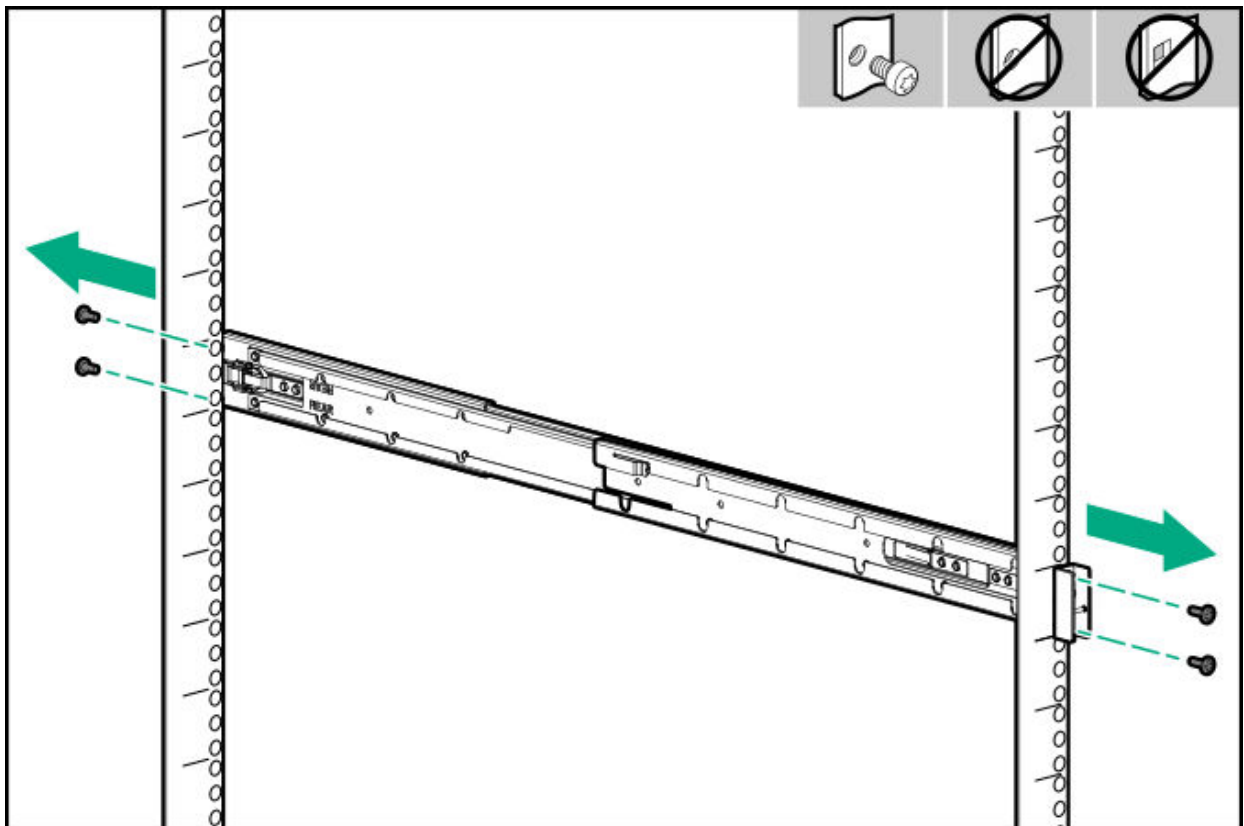

b. Press and hold the release latch, and then disengage the rail pins from the rack columns.

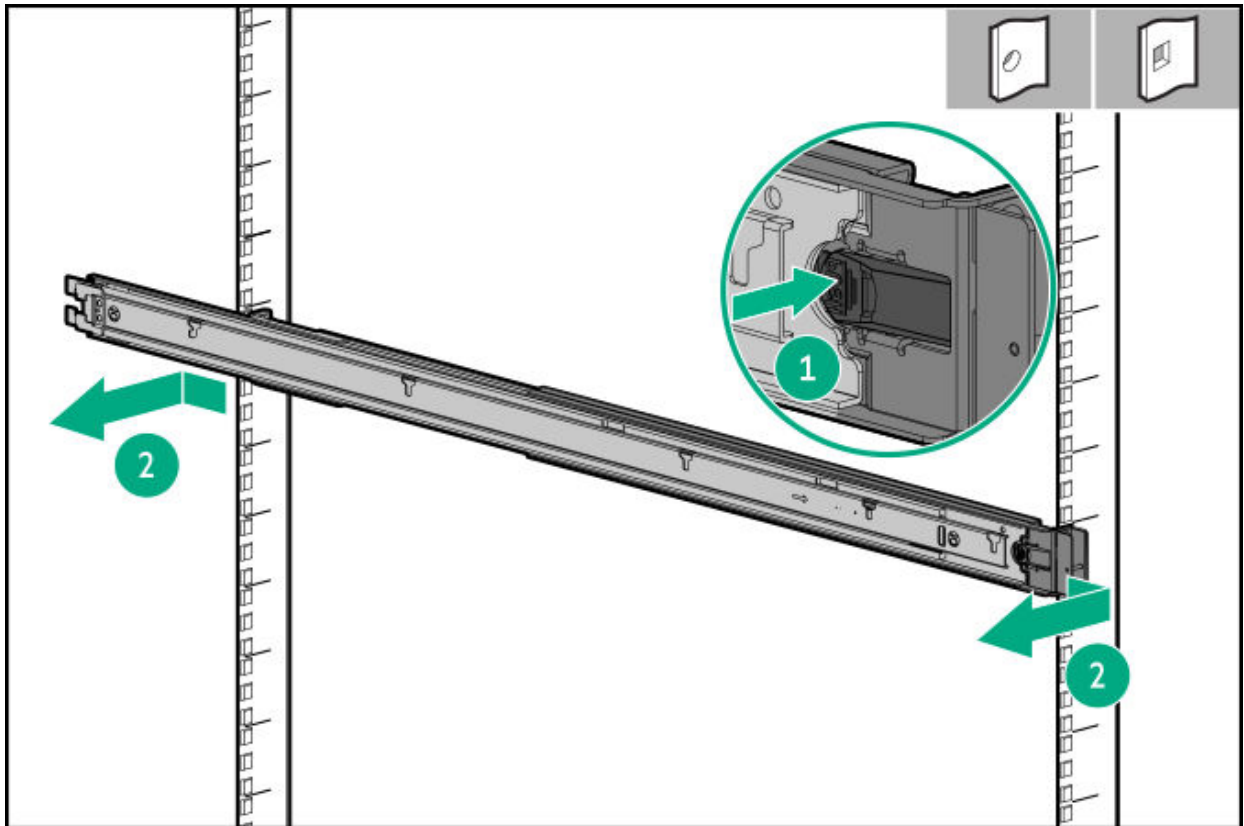

c. Repeat steps a and b to remove the other rack rail.

Results

The removal procedure is complete. To replace the component, reverse this procedure.

Removing and replacing a hot-plug SAS, SATA or NVMe drive

About this task



CAUTION

To prevent improper cooling and thermal damage, do not operate the server unless all bays are populated with either a component or a blank.



CAUTION

A discharge of static electricity from a finger or other conductor might damage system boards or other static-sensitive devices. To prevent damage, observe [antistatic precautions](#).

Procedure

1. [Back up all server data](#).
2. If installed, [remove the front bezel](#).
3. Determine the status of the drive from the [hot-plug drive LED definitions](#).
4. Remove the drive.
 - LFF drive

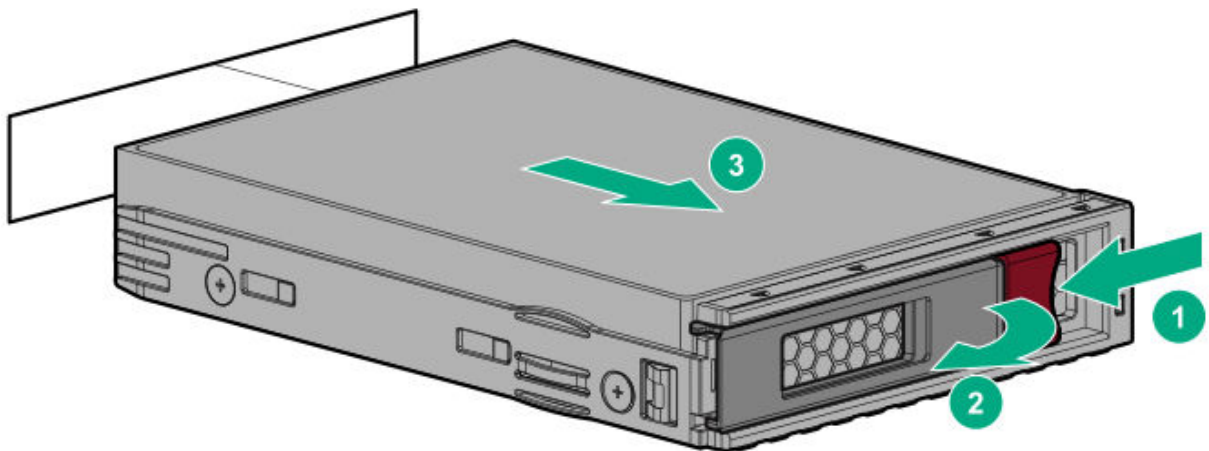

- SFF drive

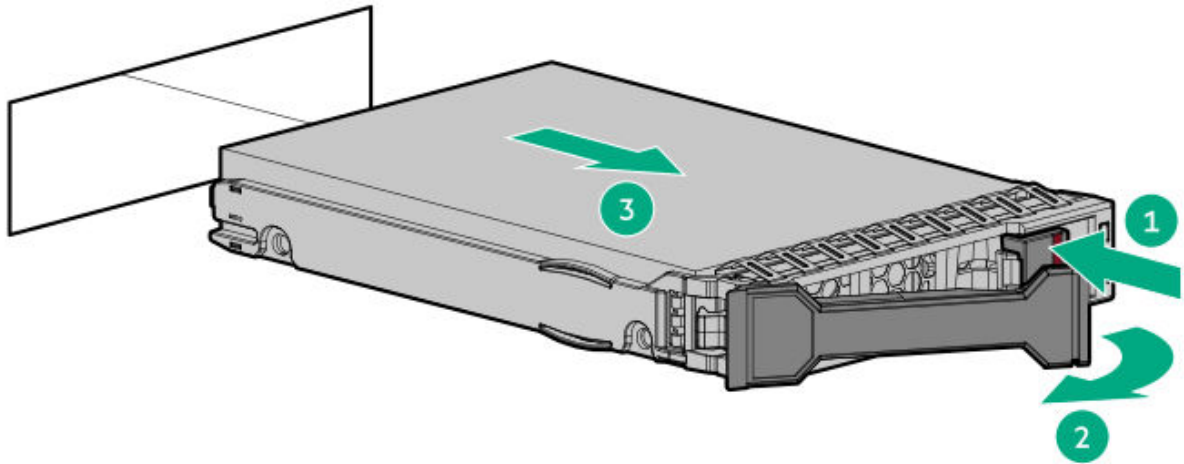

Results

The removal procedure is complete. To replace the component, reverse this procedure.

Removing and replacing a drive blank

About this task

https://sketchfab.com/models/ebfa72a6e53c4241b82df150ca59c962/embed?ui_infos=0&ui_watermark=0&ui_help=0&ui_vr=0&ui_settings=0&ui_inspector=0&ui_hint=2&ui_color=01a982&ui_theme=dark&autostart=1&camera=0&



CAUTION

To prevent improper cooling and thermal damage, do not operate the server unless all bays are populated with either a component or a blank.

Procedure

1. If installed, remove the front bezel.
2. Remove the drive blank.
 - LFF drive blank

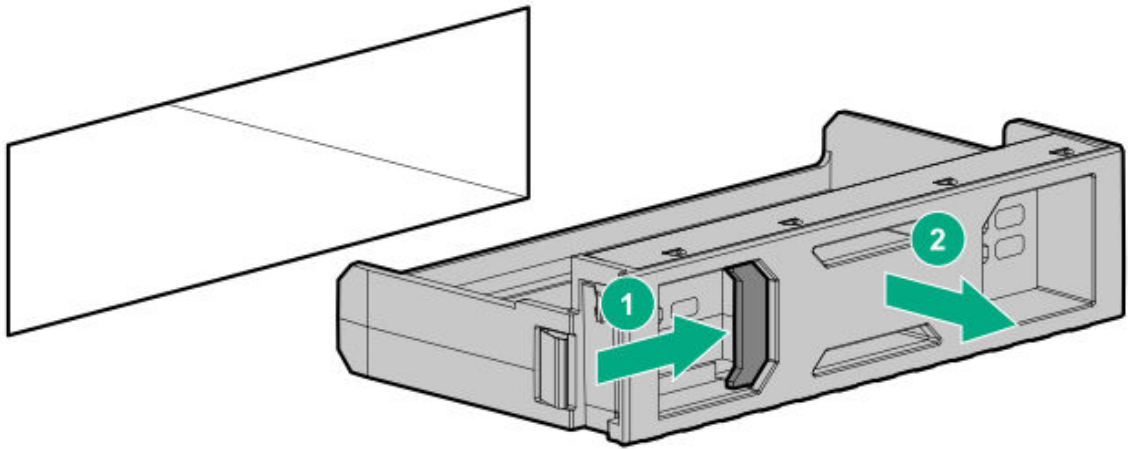

- SFF drive blank

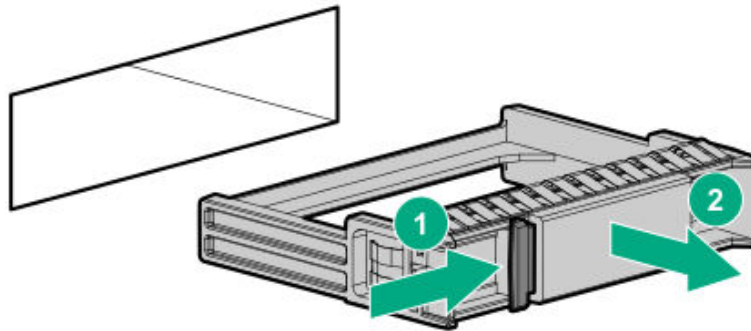

- E3.S drive blank

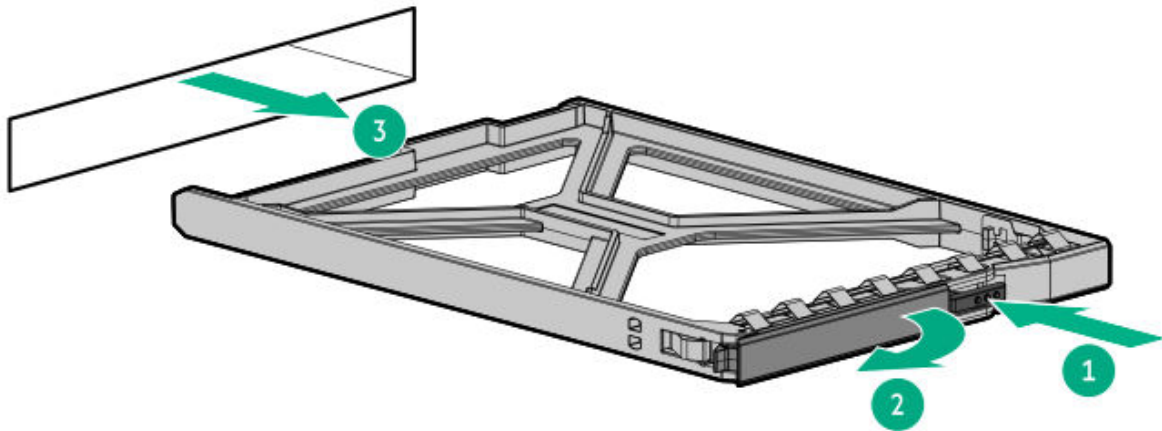

Results

The removal procedure is complete. To replace the component, reverse this procedure.

Removing and replacing a drive box blank

Prerequisites

Before you perform this procedure, make sure that you have a T-10 Torx screwdriver available.

About this task

This drive box blank is supported in the 10 SFF / 20 E3.S server.



CAUTION

To prevent improper cooling and thermal damage, do not operate the server unless all bays are populated with either a component or a blank.

Procedure

1. If installed, remove the front bezel.
2. Remove the drive box blank.

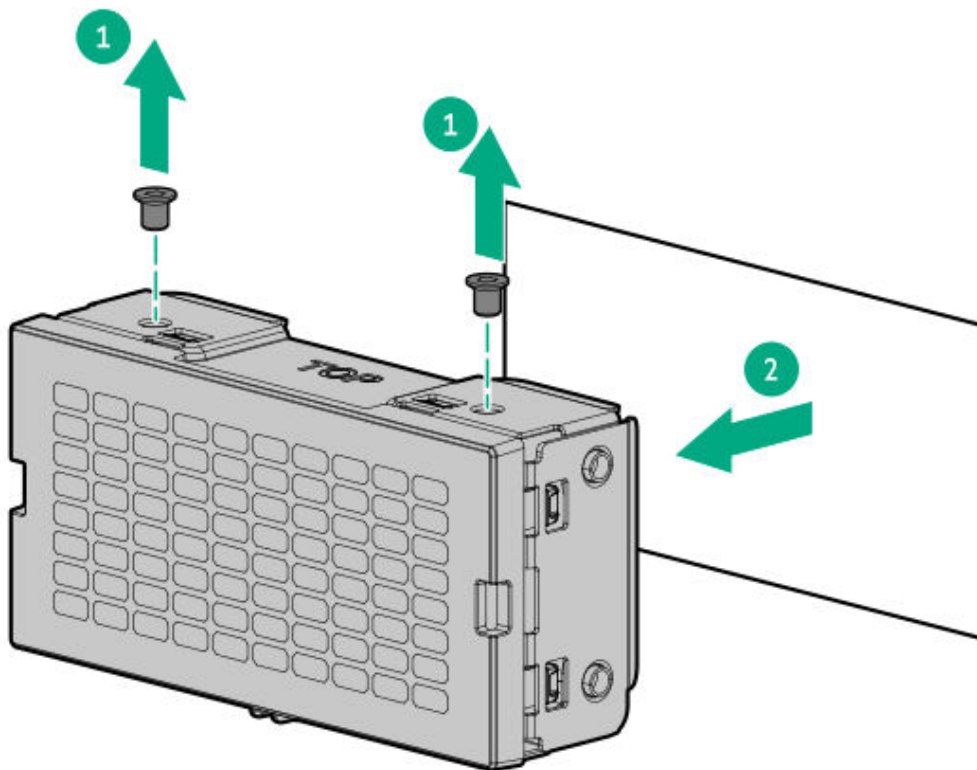

Results

The removal procedure is complete. To replace the component, reverse this procedure.

Removing and replacing an E3.S drive cage filler

Prerequisites

Before you perform this procedure, make sure that you have a small slotted screwdriver available.

About this task

https://sketchfab.com/models/be12fb70179e4650ad08a5f691195e82/embed?ui_infos=0&ui_watermark=0&ui_help=0&ui_vr=0&ui_settings=0&ui_inspector=0&ui_hint=2&ui_color=01a982&ui_theme=dark&autostart=1&camera=0&



CAUTION

To prevent improper cooling and thermal damage, do not operate the server unless all bays are populated with either a component or a blank.

Procedure

1. If installed, remove the front bezel.
2. Remove the E3.S drive cage filler:
 - a. Insert a small-slotted screwdriver into the slot on the far left to push the release latch.
 - b. Remove the E3.S drive cage filler.

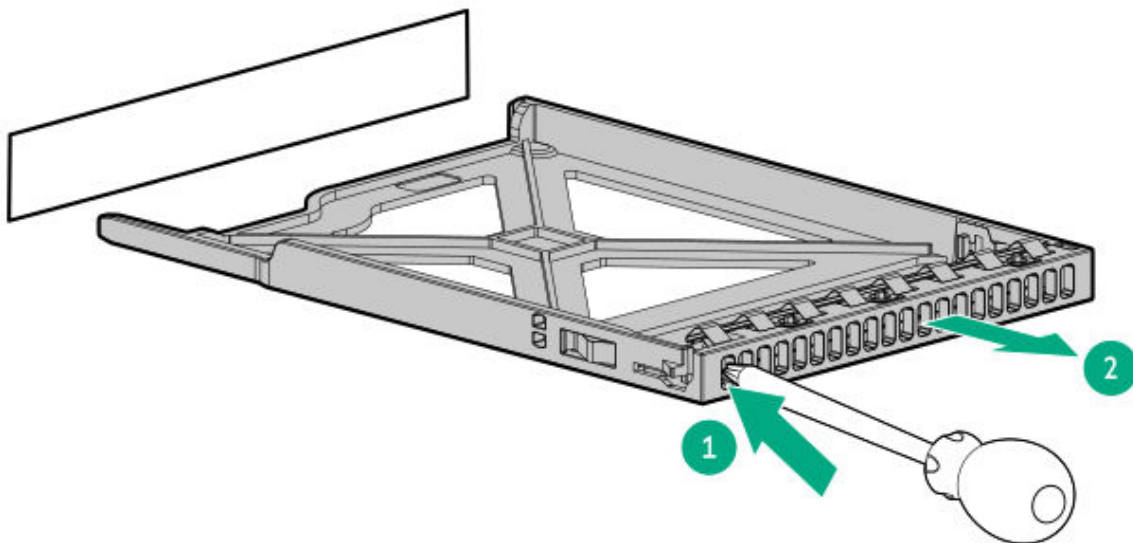

Results

The removal procedure is complete. To replace the component, reverse this procedure.

Chassis ear replacement

Subtopics

[Removing and replacing the left chassis ear](#)

[Removing and replacing the right chassis ear and power switch board](#)

Removing and replacing the left chassis ear

Prerequisites

Before you perform this procedure, make sure that you have a T-10 Torx screwdriver available.

Procedure

1. If installed, remove the front bezel.
2. Power down the server.
3. If installed, release the cable management arm.
4. Remove all power:
 - a. Disconnect each power cord from the power source.
 - b. Disconnect each power cord from the server.
5. Disconnect all peripheral cables from the server.
6. Remove the server from the rack.
7. Place the server on a flat, level work surface.
8. Remove the left chassis ear:
 - a. Remove left chassis ear screws.

Retain the screws to secure the new left chassis ear spare.
 - b. Detach the left chassis ear.

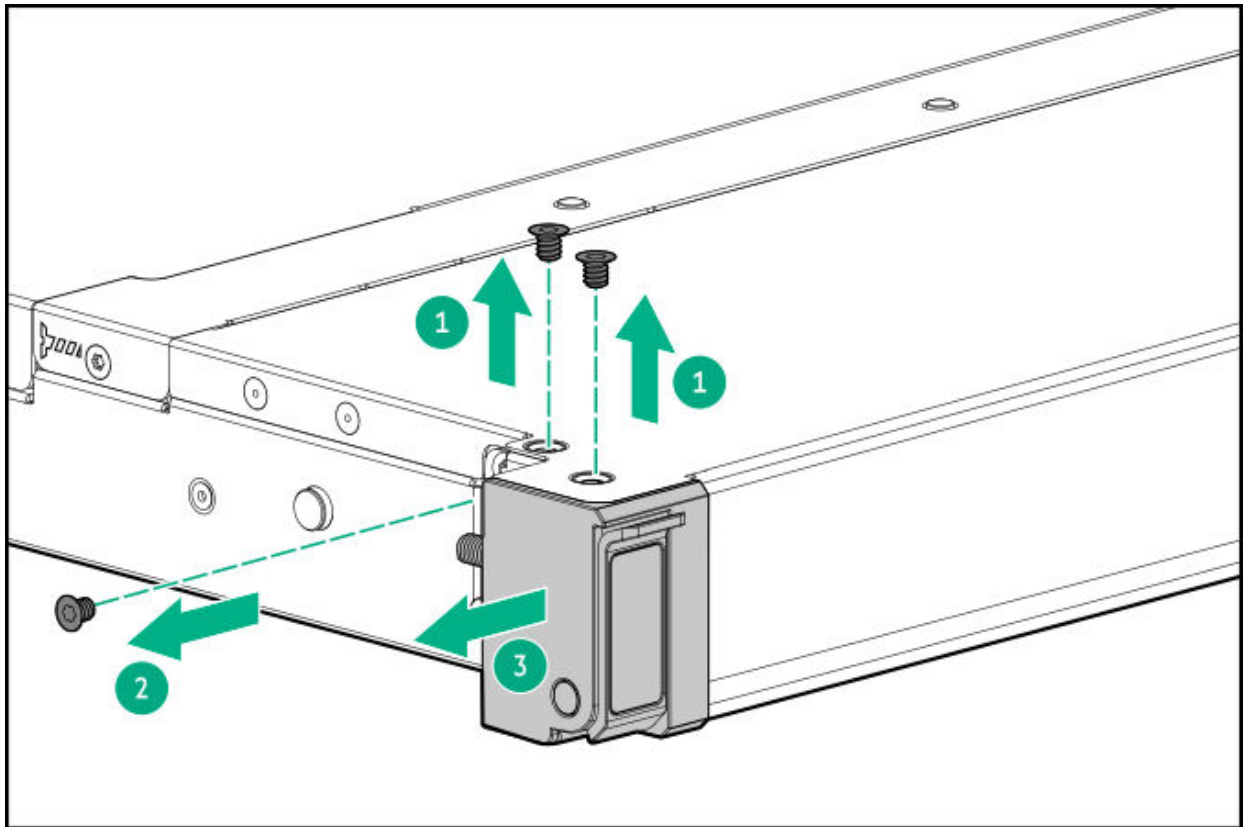

Results

The removal procedure is complete. To replace the component, reverse this procedure.

Removing and replacing the right chassis ear and power switch board

Prerequisites

Before you perform this procedure, make sure that you have a T-10 Torx screwdriver available.

About this task



CAUTION

A discharge of static electricity from a finger or other conductor might damage system boards or other static-sensitive devices. To prevent damage, observe [antistatic precautions](#).

Procedure

1. If installed, remove the front bezel.
2. Power down the server.
3. Remove all power:
 - a. Disconnect each power cord from the power source.
 - b. Disconnect each power cord from the server.
4. Do one of the following:
 - Extend the server from the rack.
 - Remove the server from the rack.
5. Remove the access panel.
6. Disconnect the cable from the system board.

Removing the right ear in the 10 SFF / 20 E3.S server or 8 SFF server

7. Remove the right chassis ear:
 - a. Remove the screws.
 - b. Pull the right ear and front I/O port assembly simultaneously.

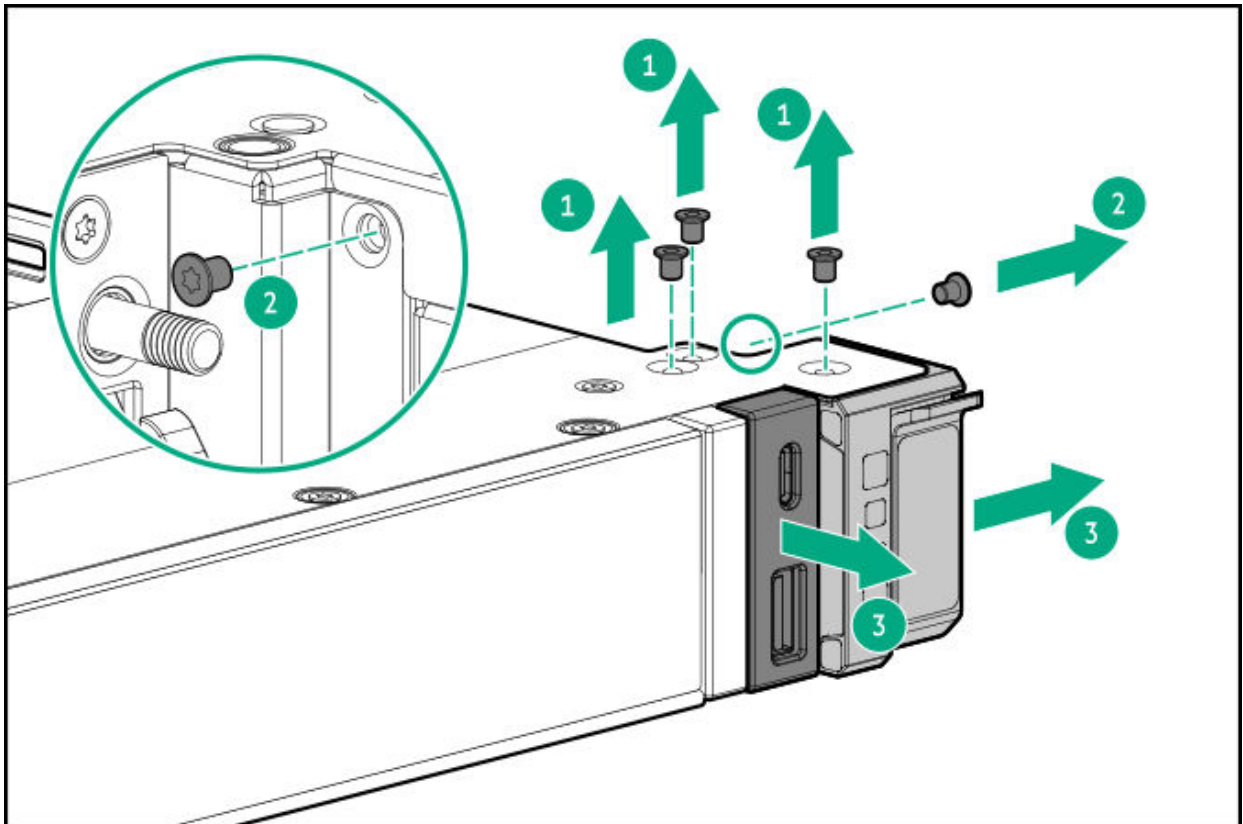

8. Remove the front I/O cable from the front USB panel.

Retain the front USB panel. The front USB panel will be used to secure the new right chassis ear spare.



9. Remove the USB cable from the support bracket.

Retain the support bracket and screw. The support bracket and screw will be used to secure the new right chassis ear spare.

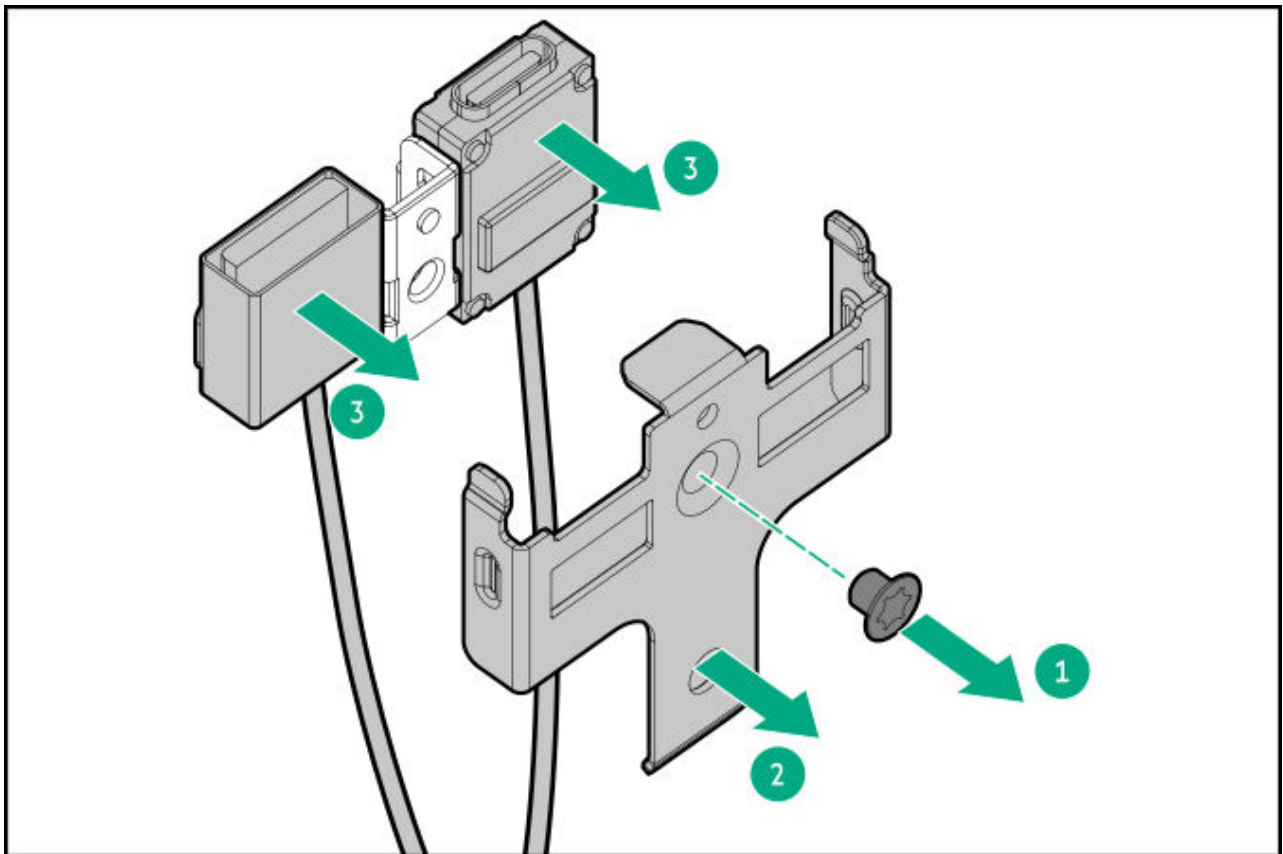

Removing the right ear in the LFF drive configuration

10. Remove the right chassis ear:
 - a. Remove the screws.
 - b. Pull the right ear and front I/O port assembly simultaneously.

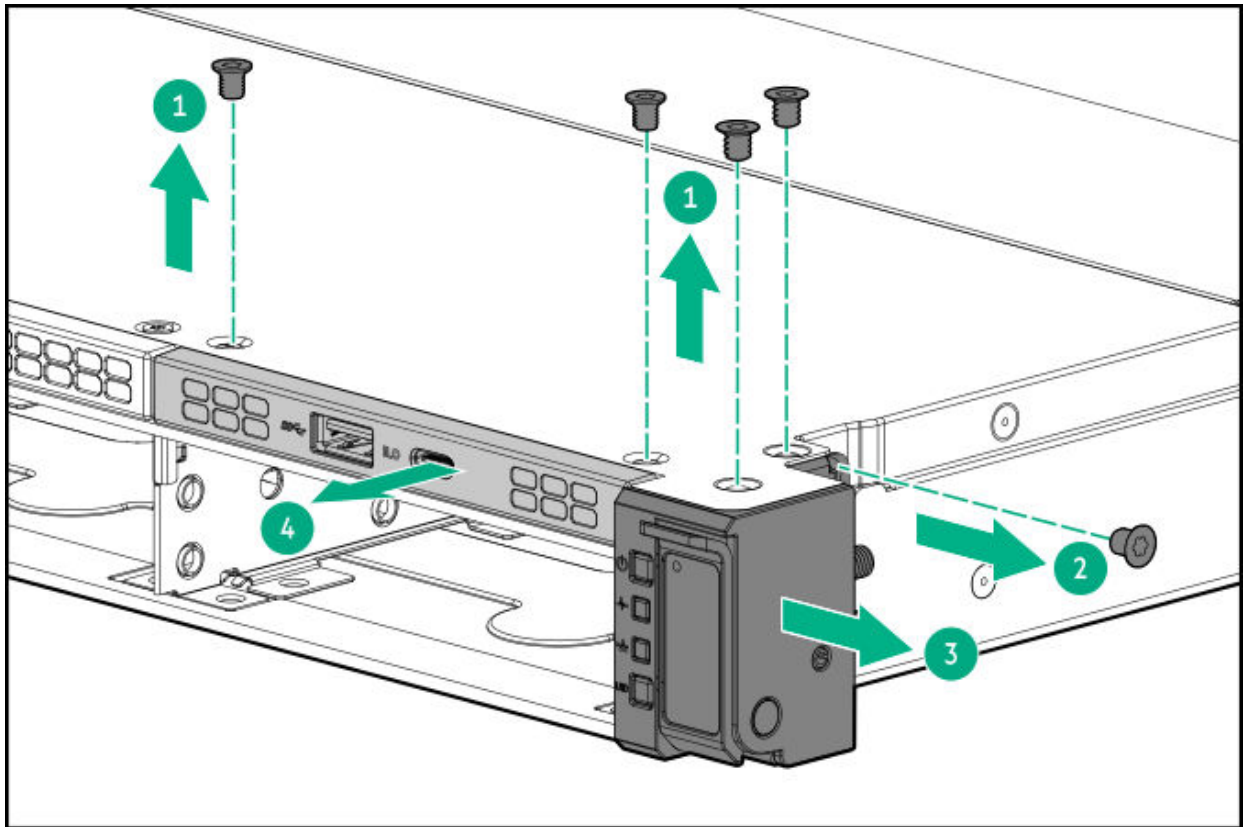

.1. Remove the front I/O port assembly from the cage.

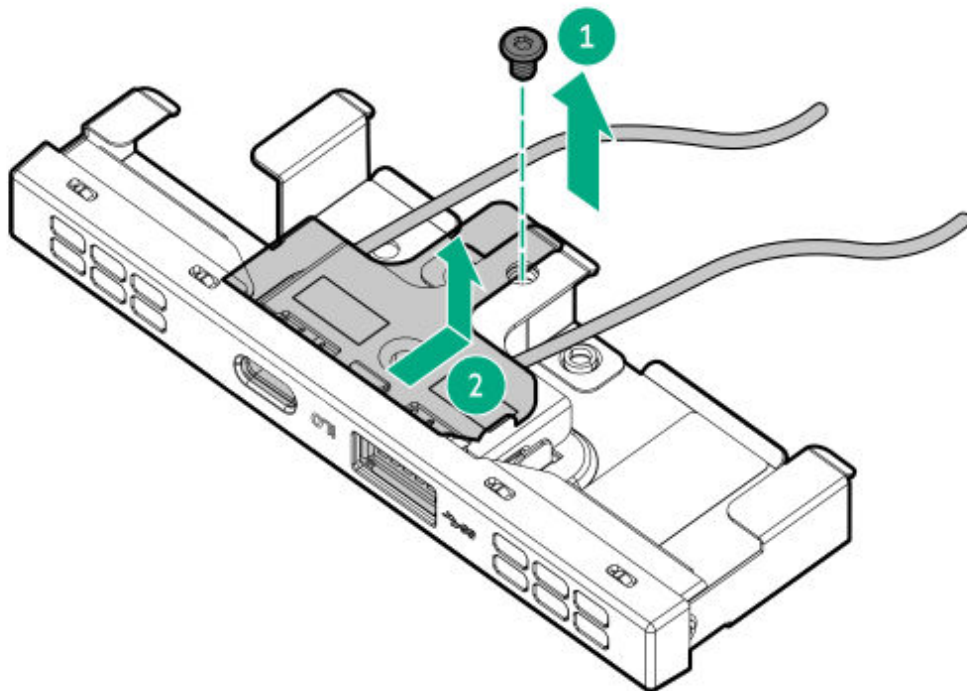

(Optional) Removing the switch board

- .2. Remove the power switch board:
 - a. Remove the screw to remove the right ear cover.
 - b. Remove the switch board.

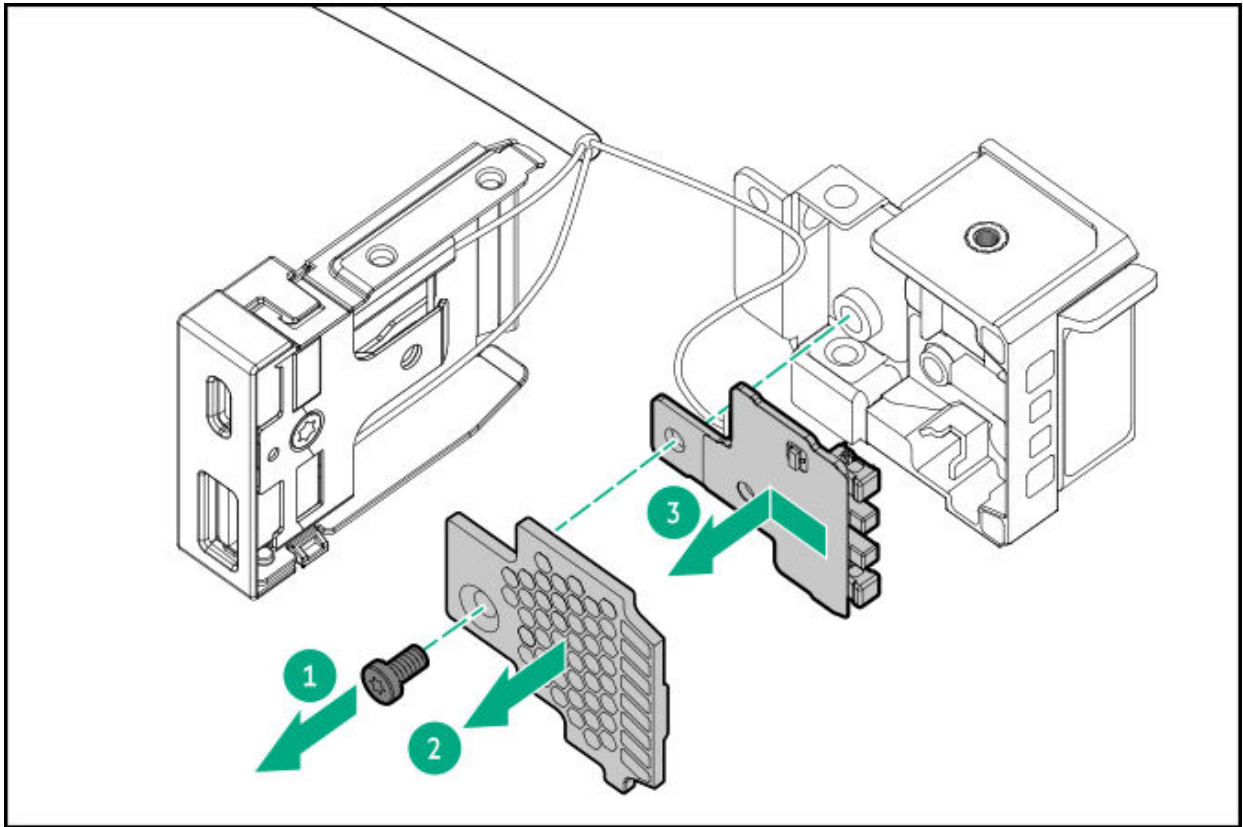

- c. Unlock the connector and disconnect the front I/O cable.

Retain the front I/O cable. The cable will be connected to the new switch board spare.

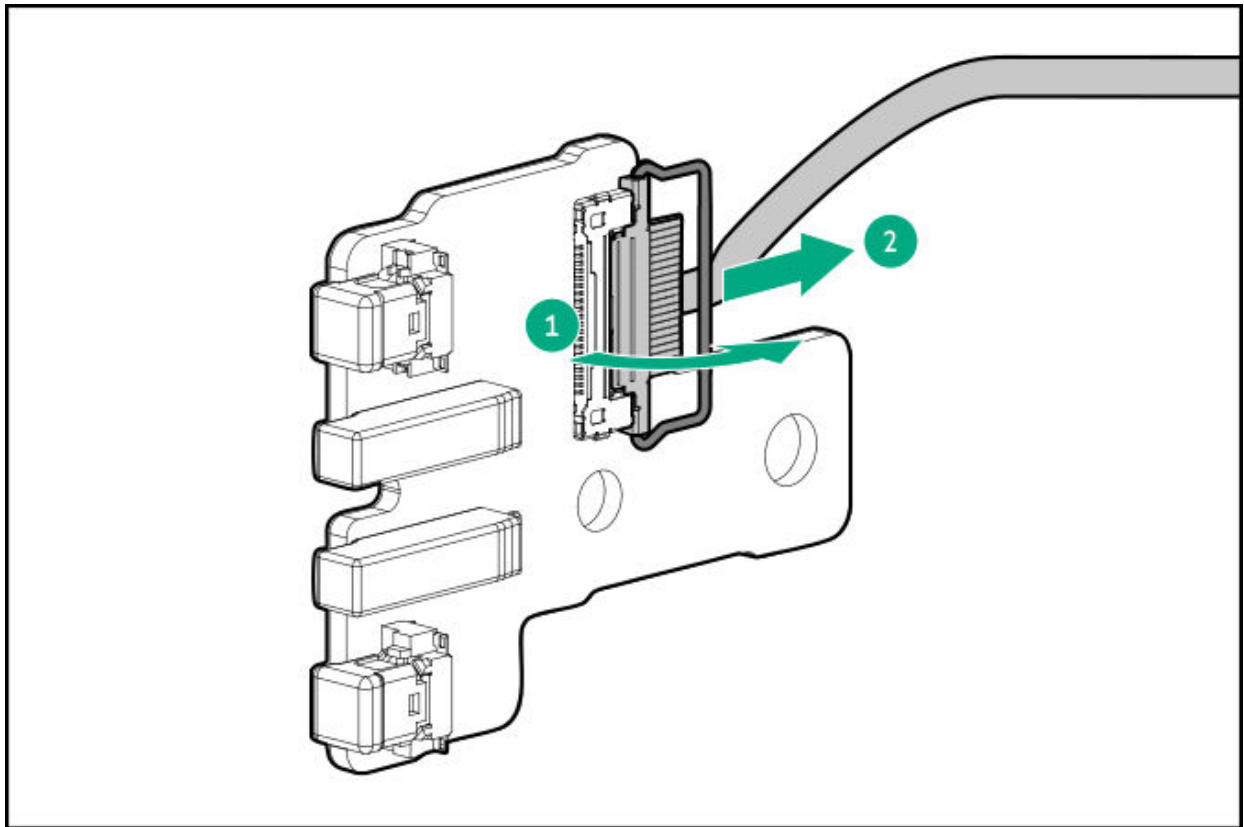

d. Remove the Mylar from the back of the switch board.

Retain the Mylar. The Mylar will be installed on the new switch board spare.

Results

The removal procedure is complete. To replace the component, reverse this procedure.

Removing and replacing a power supply blank

About this task



WARNING

To reduce the risk of personal injury from hot surfaces, allow the power supply, power supply blank, or dual slot power supply adapter to cool before touching it.



CAUTION

To prevent improper cooling and thermal damage, do not operate the server unless all bays are populated with either a component or a blank.

Procedure

1. Remove the power supply blank.

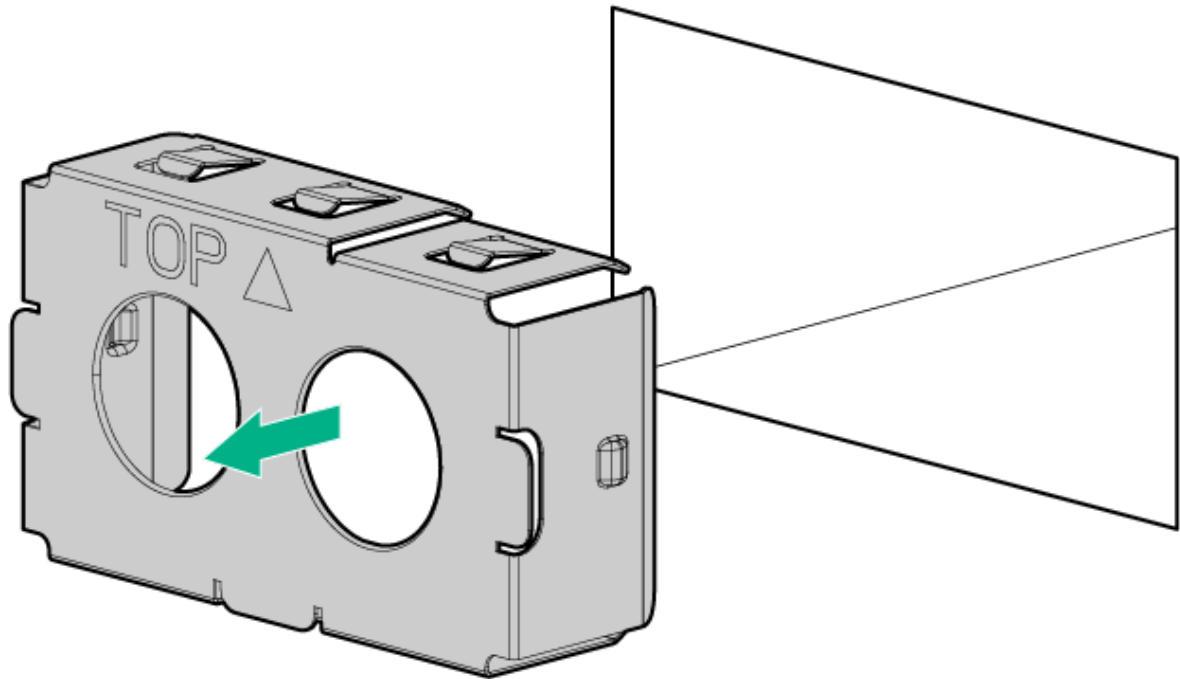

2. Immediately install the replacement power supply blank spare.

Flexible Slot power supply replacement

Depending on the configuration and the regional location where the server was purchased, the server can be configured with one of the supported [power supplies](#).

Subtopics

[Power supply warnings and cautions](#)

[DC power supply warnings and cautions](#)

[DC power supply wire colors](#)

[Removing and replacing a hot-plug AC power supply](#)

[Removing and replacing a DC Flexible Slot power supply](#)

Power supply warnings and cautions



WARNING

To reduce the risk of electric shock or damage to the equipment:

- Do not disable the power cord grounding plug. The grounding plug is an important safety feature.
- Plug the power cord into a grounded (earthed) electrical outlet that is easily accessible at all times.
- Unplug the power cord from the power supply to disconnect power to the equipment.
- Do not route the power cord where it can be walked on or pinched by items placed against it. Pay particular attention to the plug, electrical outlet, and the point where the cord extends from the server.



WARNING

To reduce the risk of injury from electric shock hazards, do not open power supplies. Refer all maintenance, upgrades, and servicing to qualified personnel.



CAUTION

Mixing different types of power supplies in the same server might:

- Limit or disable some power supply features including support for power redundancy.
- Cause the system to become unstable and might shut down.

To ensure access to all available features, all power supplies in the same server should have the same output and efficiency ratings. Verify that all power supplies have the same part number and label color.

DC power supply warnings and cautions



WARNING

To reduce the risk of electric shock, be sure that the cable grounding kit is properly installed and connected to a suitable protective earth terminal before connecting the power source to the rack.



CAUTION

This equipment is designed to permit the connection of the earthed conductor of the DC supply circuit to the earthing conductor at the equipment. If this connection is made, all the following must be met:

- This equipment must be connected directly to the DC supply system earthing electrode conductor or to a bonding jumper from an earthing terminal bar or bus to which the DC supply system earthing electrode conductor is connected.
- This equipment must be located in the same immediate area (such as adjacent cabinets) as any other equipment that has a connection between the earthed conductor of the same DC supply circuit and the earthing conductor, and also the point of earthing of the DC system. The DC system must be earthed elsewhere.
- The DC supply source is to be located within the same premises as the equipment.
- Switching or disconnecting devices must not be in the earthed circuit conductor between the DC source and the point of connection of the earthing electrode conductor.

DC power supply wire colors

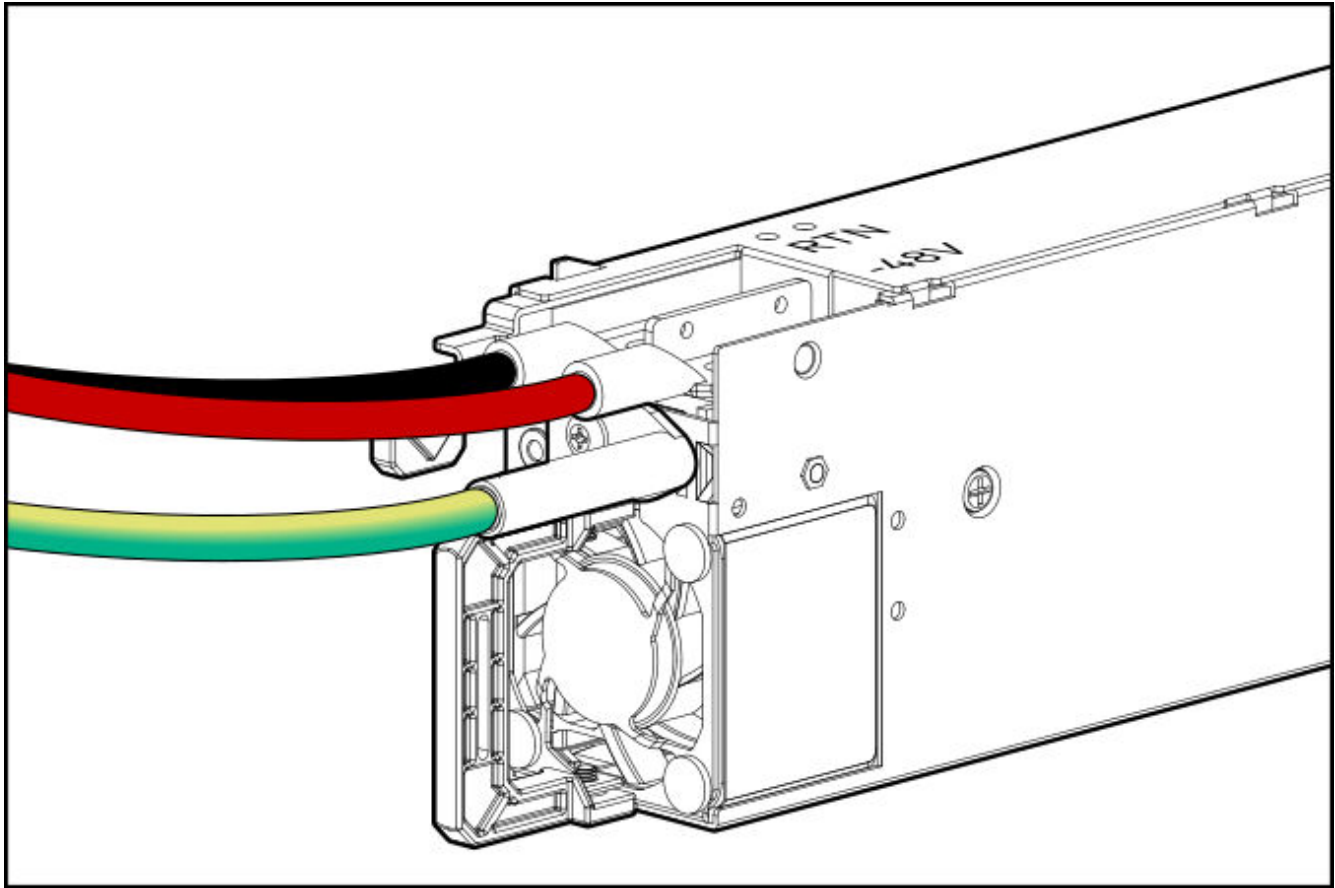

Wire color	Description	Wire slot
Red	Line wire	-48V
Black	Return wire	Return
Green + Yellow	Ground wire	Safety ground

Removing and replacing a hot-plug AC power supply

Prerequisites

Before you perform this procedure, make sure that you have the following items:

- Components included with the hardware kit
- No. 1 Phillips screwdriver

About this task



WARNING

To reduce the risk of electric shock or damage to the equipment:

- Do not disable the power cord grounding plug. The grounding plug is an important safety feature.
- Plug the power cord into a grounded (earthed) electrical outlet that is easily accessible at all times.
- Unplug the power cord from the power supply to disconnect power to the equipment.
- Do not route the power cord where it can be walked on or pinched by items placed against it. Pay particular attention to the plug, electrical outlet, and the point where the cord extends from the server.



WARNING

To reduce the risk of personal injury, fire, or damage to the equipment, do not overload the AC supply branch circuit that provides power to the rack. Consult the electrical authority having jurisdiction over wiring and installation requirements of your facility.



WARNING

To reduce the risk of personal injury from hot surfaces, allow the drives and the internal system components to cool before touching them.



CAUTION

To prevent damage to electrical components, properly ground the server before beginning any installation procedure. Improper grounding can cause electrostatic discharge.



CAUTION

To prevent improper cooling and thermal damage, do not operate the server or the enclosure unless all drive and device bays are populated with either a component or a blank.



CAUTION

Mixing different types of power supplies in the same server might:

Procedure

1. Release the cable management arm.
2. If the server is using a single power supply only, remove all power from the server:
 - a. Back up all server data.
 - b. Power down the server.
 - c. Disconnect all peripheral cables from the server.
3. Release the power cords from the strain relief straps.

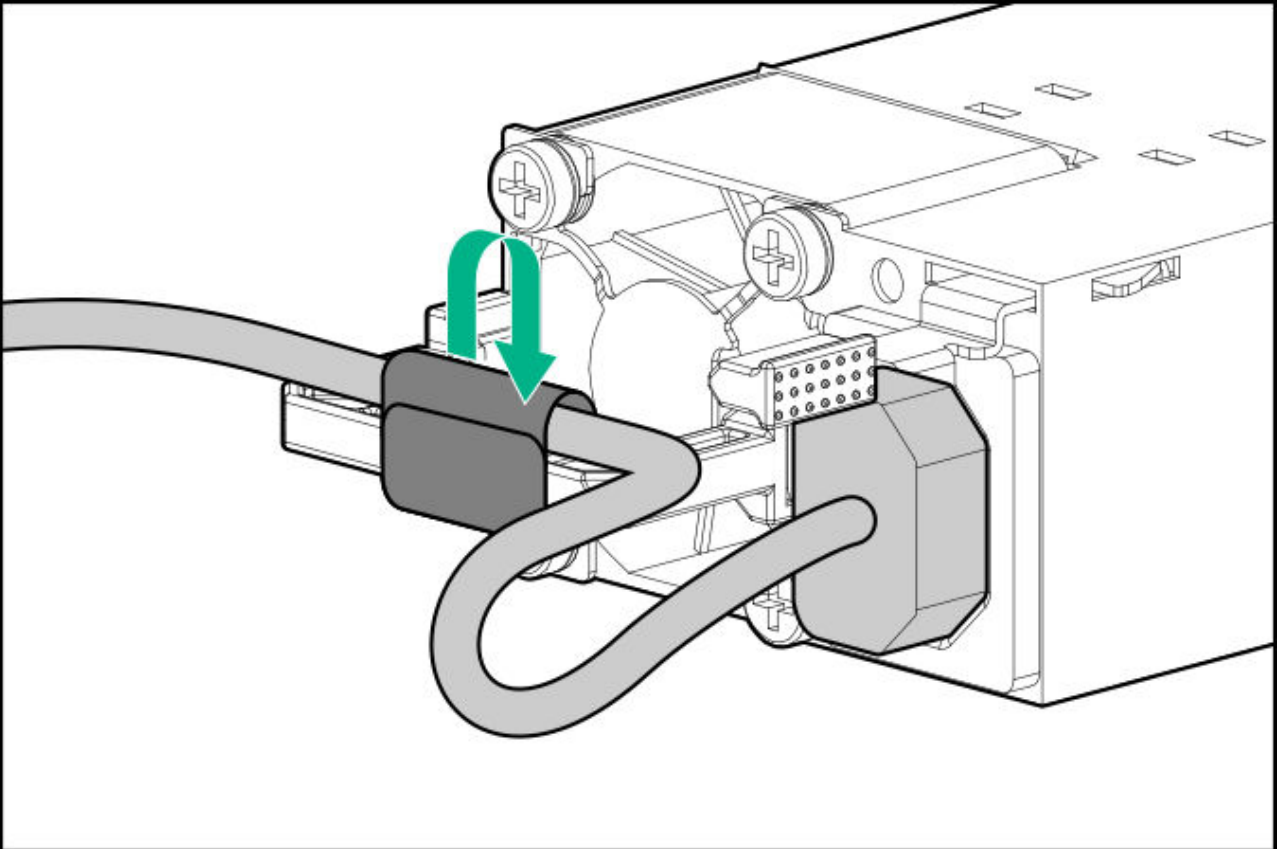

4. Disconnect the power cord from the power supply.

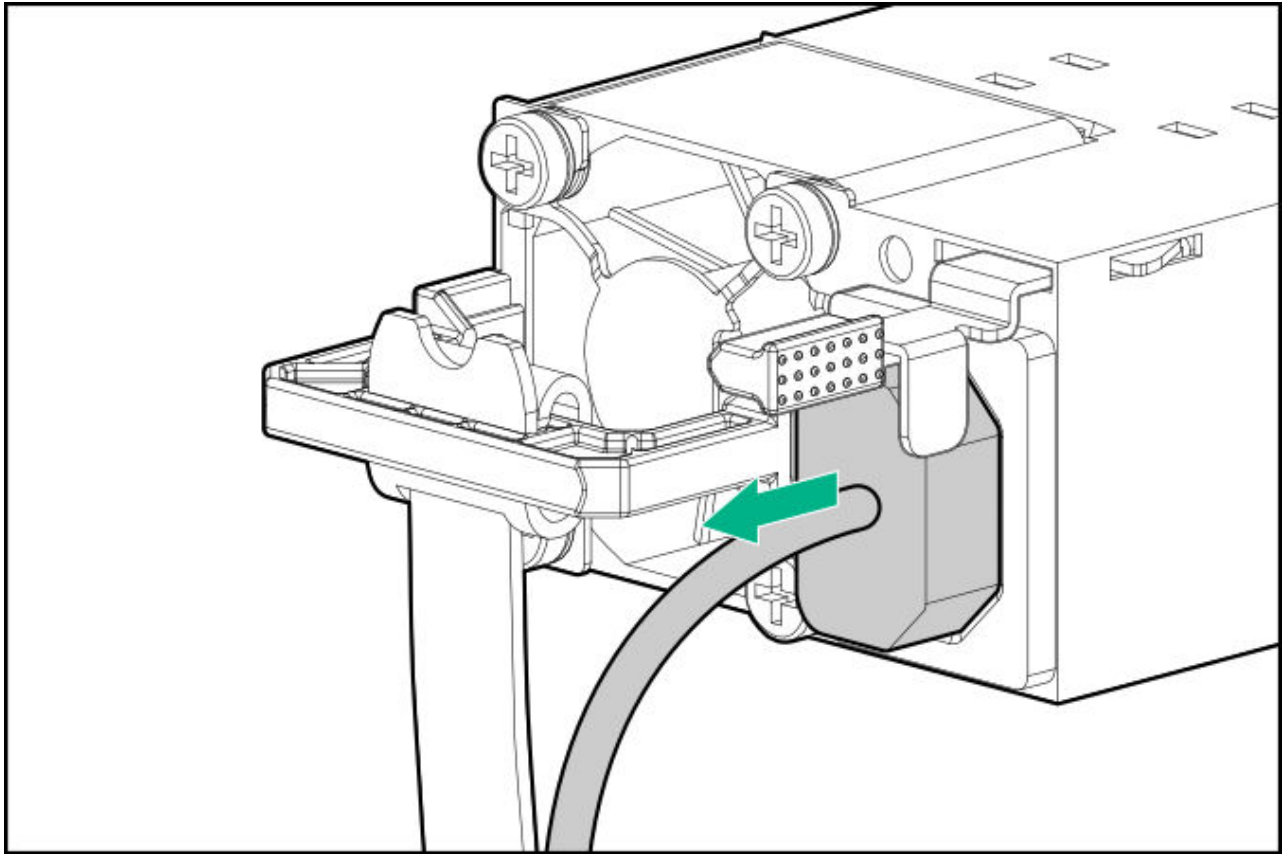

5. Remove the power supply.

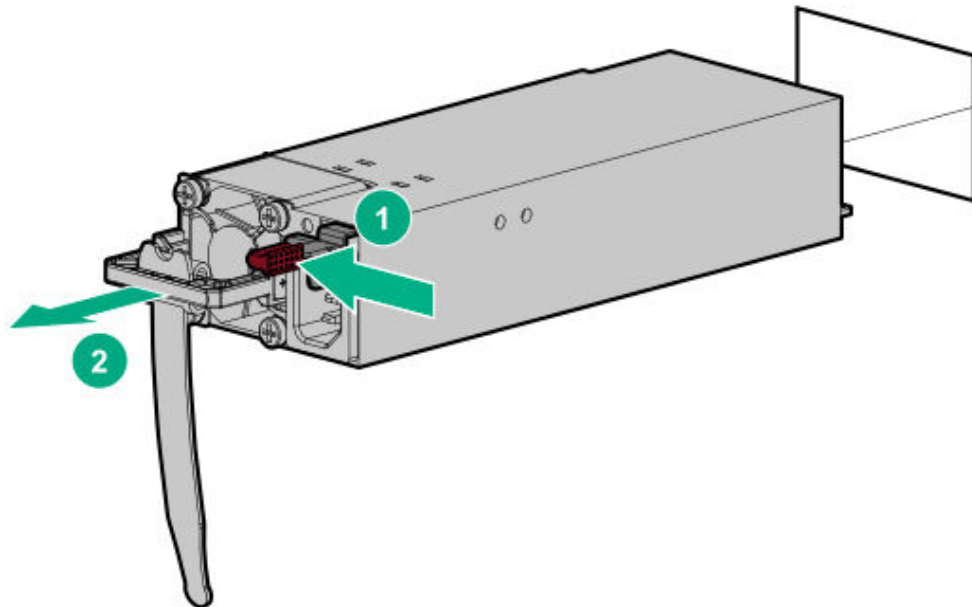

Results

To replace the component, reverse the removal procedure.

Removing and replacing a DC Flexible Slot power supply

Prerequisites

- Before replacing a power supply, review the following:
 - [Power supply warnings and cautions](#)
 - [DC power supply warnings and cautions](#)
 - [DC power supply wire colors](#)
- Before you perform this procedure, make sure that you have a Phillips No. 2 screwdriver available.

About this task



WARNING

To reduce the risk of personal injury from hot surfaces, allow the power supply, power supply blank, or dual slot power supply adapter to cool before touching it.



CAUTION

To prevent improper cooling and thermal damage, do not operate the server unless all bays are populated with either a component or a blank.

Procedure

1. [Power down the server.](#)
2. To remove the DC power supply, do the following:
 - a. Remove the power supply.

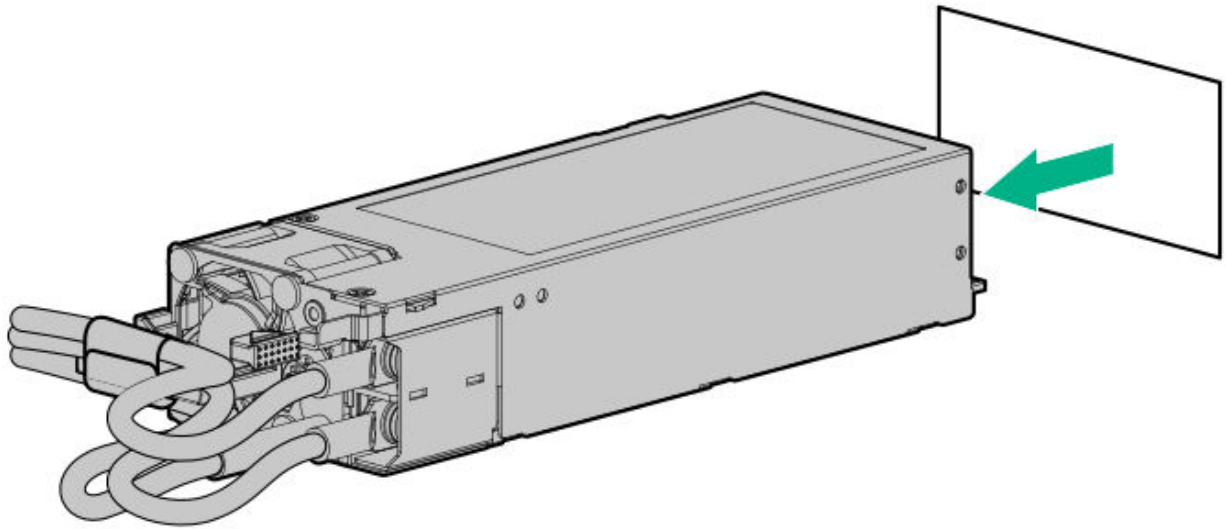

b. Release the ground, positive return, and negative input wires from the strain relief strap.

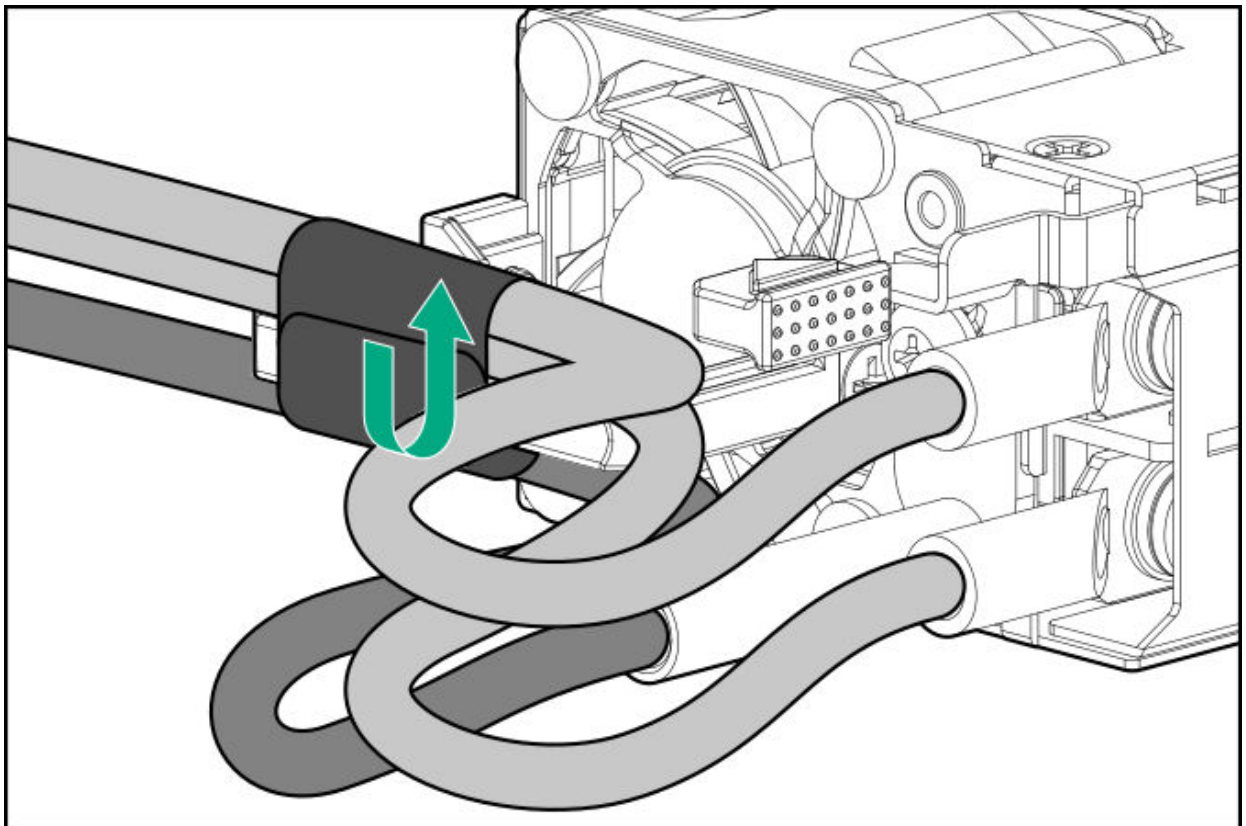

c. Remove the protective cover from the power supply.

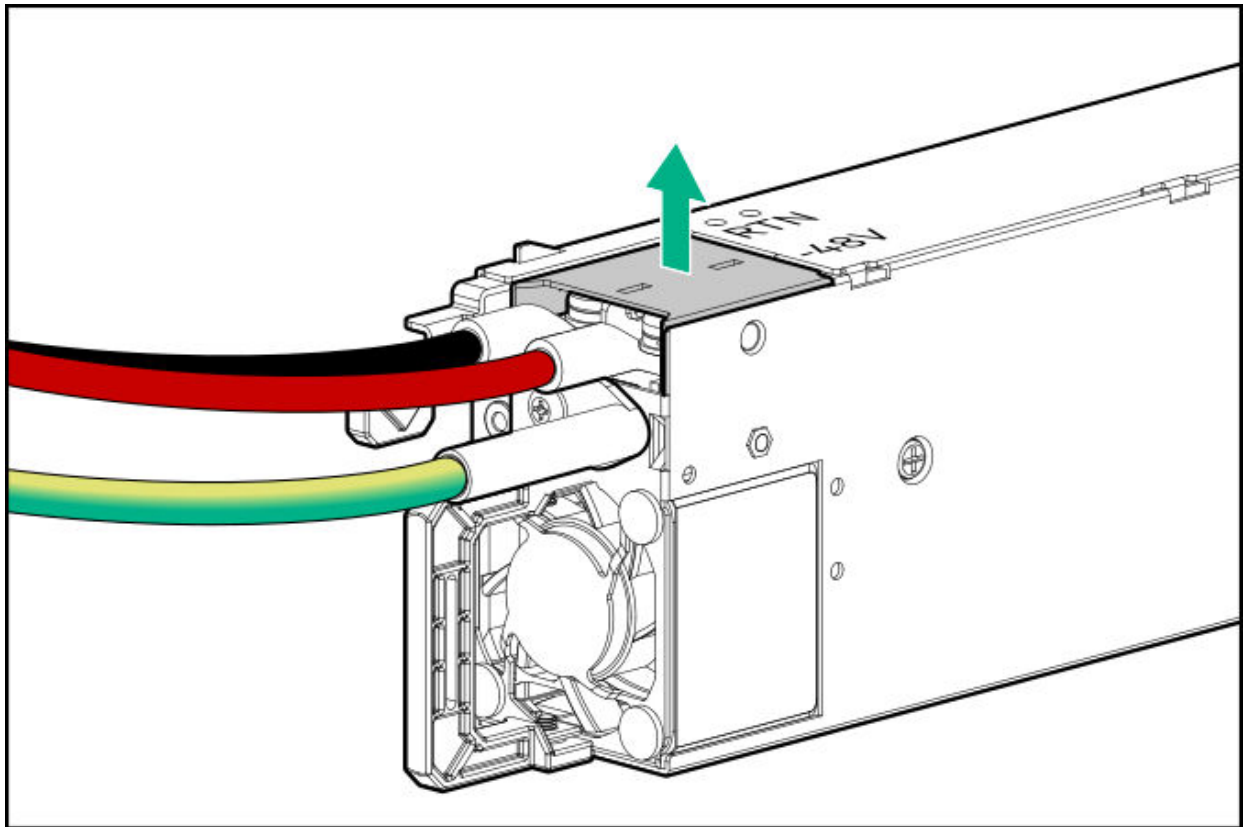

d. Remove the line wire (red) from the -48V slot on the DC power supply.

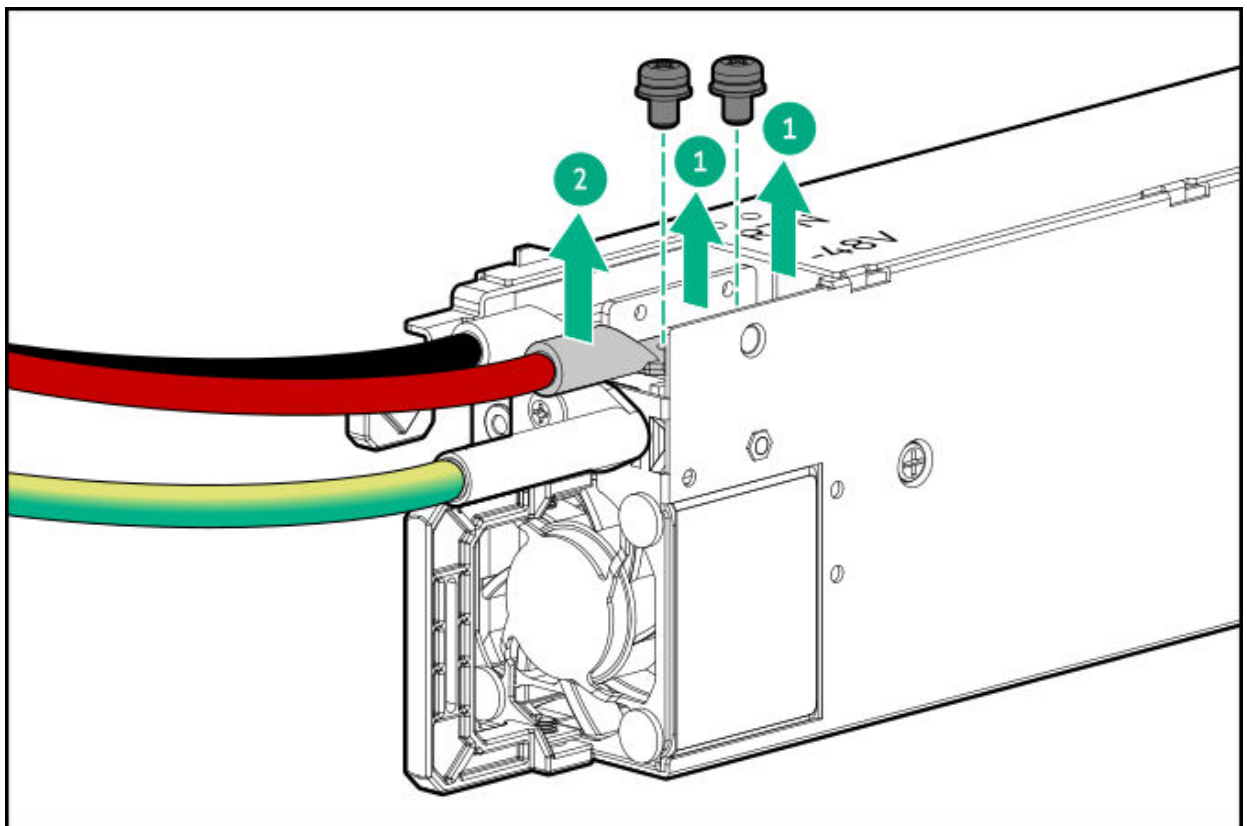

e. Remove the return wire (black) from the RTN slot on the DC power supply.

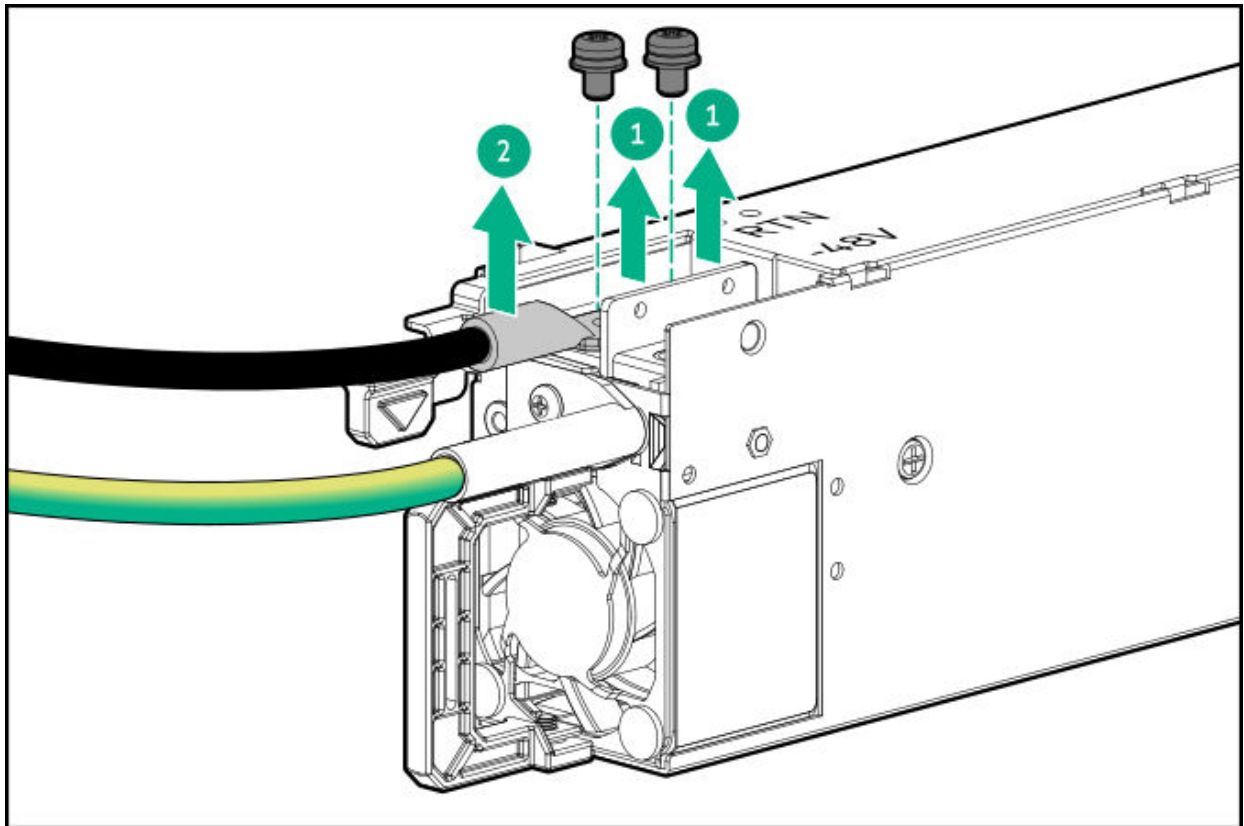

f. Remove the ground wire (green and yellow) from the DC power supply.

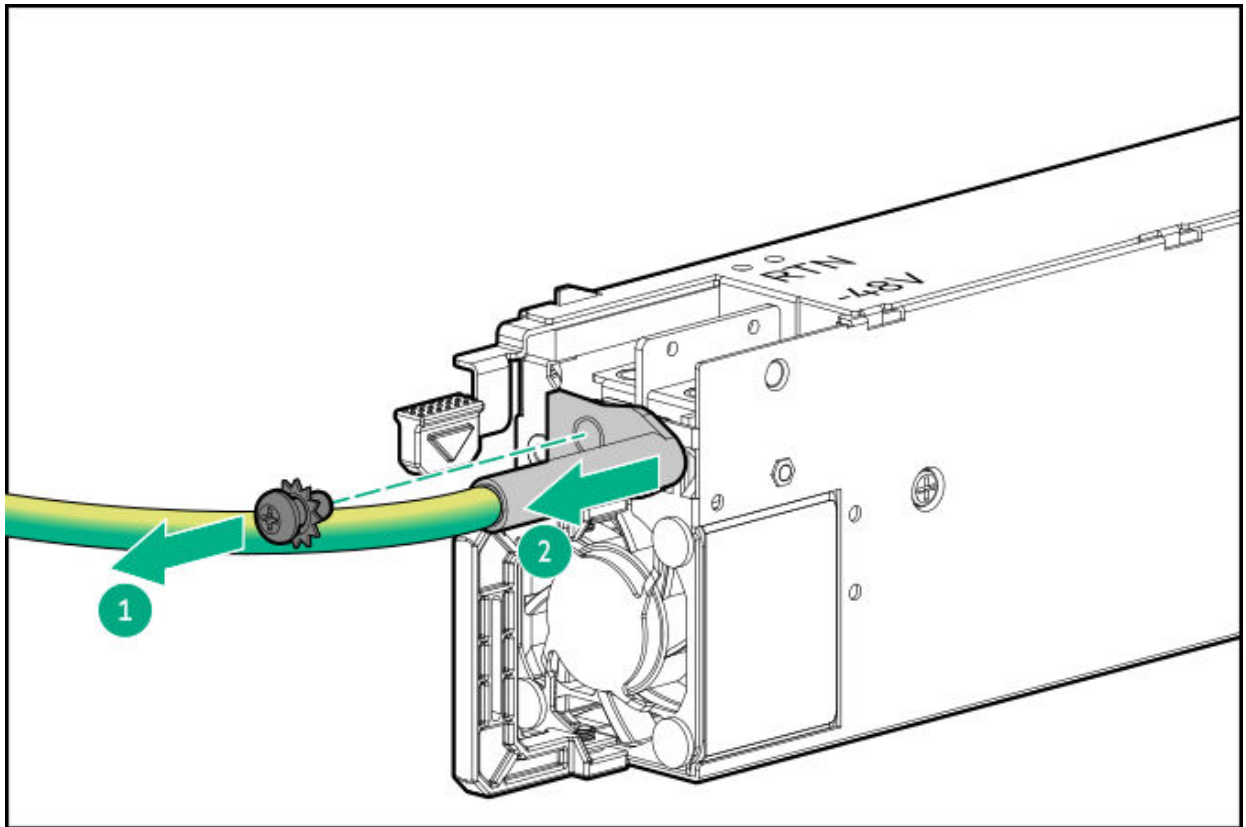

Results

The removal procedure is complete. To replace the component, reverse this procedure.

Removing and replacing the System Insight Display

Prerequisites

Before you perform this procedure, make sure that you have a T-10 Torx screwdriver available.

About this task

System Insight Display is supported in the 8 SFF server.

<https://sketchfab.com/models/4e5ead76315d4abfad48b4228e7e9764/embed?>



CAUTION

A discharge of static electricity from a finger or other conductor might damage system boards or other static-sensitive devices. To prevent damage, observe [antistatic precautions](#).

Procedure

1. [Power down the server](#).
2. Remove all power:
 - a. Disconnect each power cord from the power source.
 - b. Disconnect each power cord from the server.
3. Disconnect all peripheral cables from the server.
4. Do one of the following:
 - a. [Extend the server from the rack](#).
 - b. [Remove the server from the rack](#).
5. Place the server on a flat, level work surface.
6. [Remove the access panel](#).
7. [Disconnect the cable from the system board](#).
8. Remove the component.

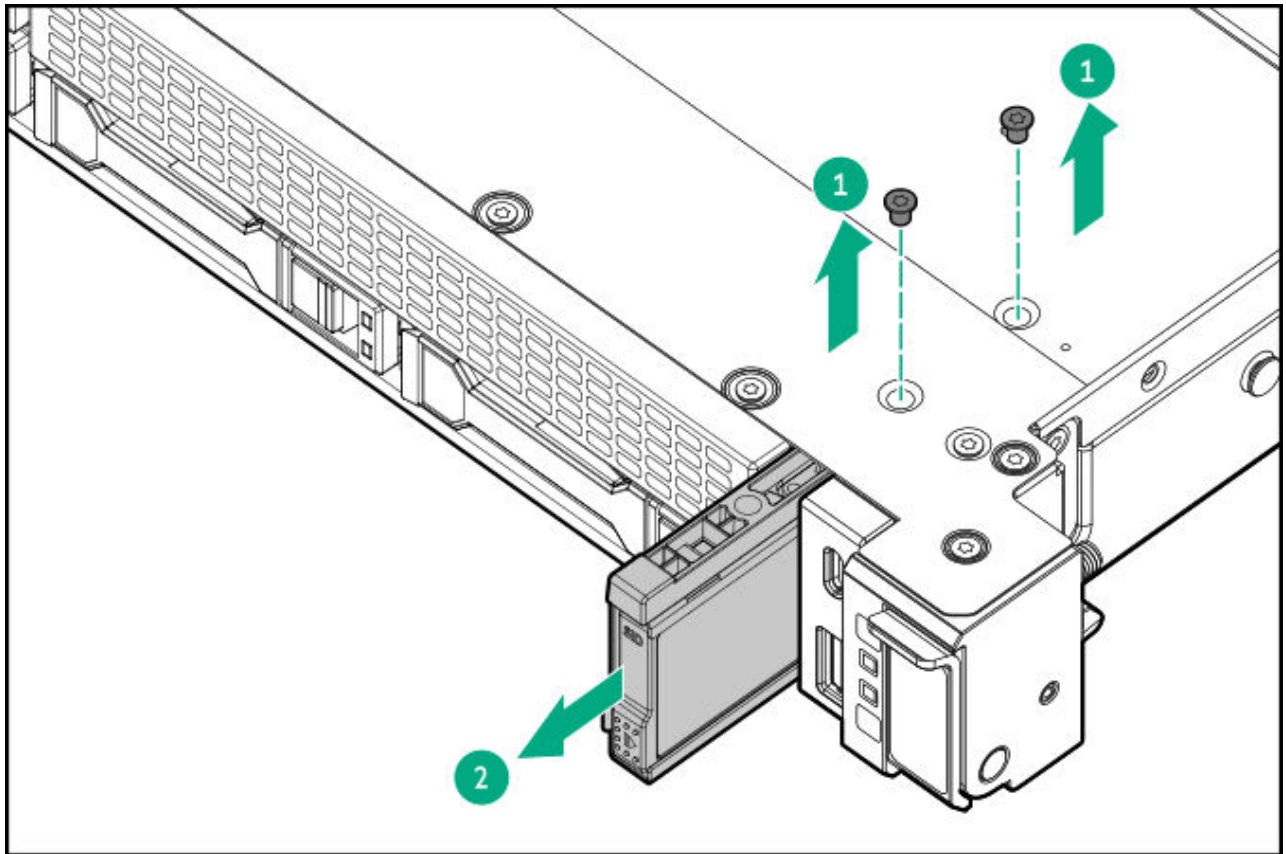

Results

The removal procedure is complete. To replace the component, reverse this procedure.

Front OCP NIC kit replacement

The front OCP NIC hardware options and spare parts are supported in the 10 SFF / 20 E3.S server.

Subtopics

Removing and replacing a front OCP NIC or carrier kit

Removing and replacing the front OCP NIC cable

Removing and replacing the OCP NIC interposer

Removing and replacing a front OCP NIC or carrier kit

Prerequisites

Before you perform this procedure, make sure that you have a T-10 Torx screwdriver available.

About this task



CAUTION

A discharge of static electricity from a finger or other conductor might damage system boards or other static-sensitive devices. To prevent damage, observe [antistatic precautions](#).



CAUTION

To prevent improper cooling and thermal damage, do not operate the server unless all bays are populated with either a component or a blank.

Procedure

1. [Back up all server data](#).
2. [Power down the server](#).
3. If installed, [release the cable management arm](#).
4. Remove all power:
 - a. Disconnect each power cord from the power source.
 - b. Disconnect each power cord from the server.
5. Disconnect all peripheral cables from the server.
6. Do one of the following:
 - [Extend the server from the rack](#).
 - [Remove the server from the rack](#).
7. [Remove the access panel](#).
8. [Remove the middle cover](#).
9. Remove the OCP NIC and carrier.

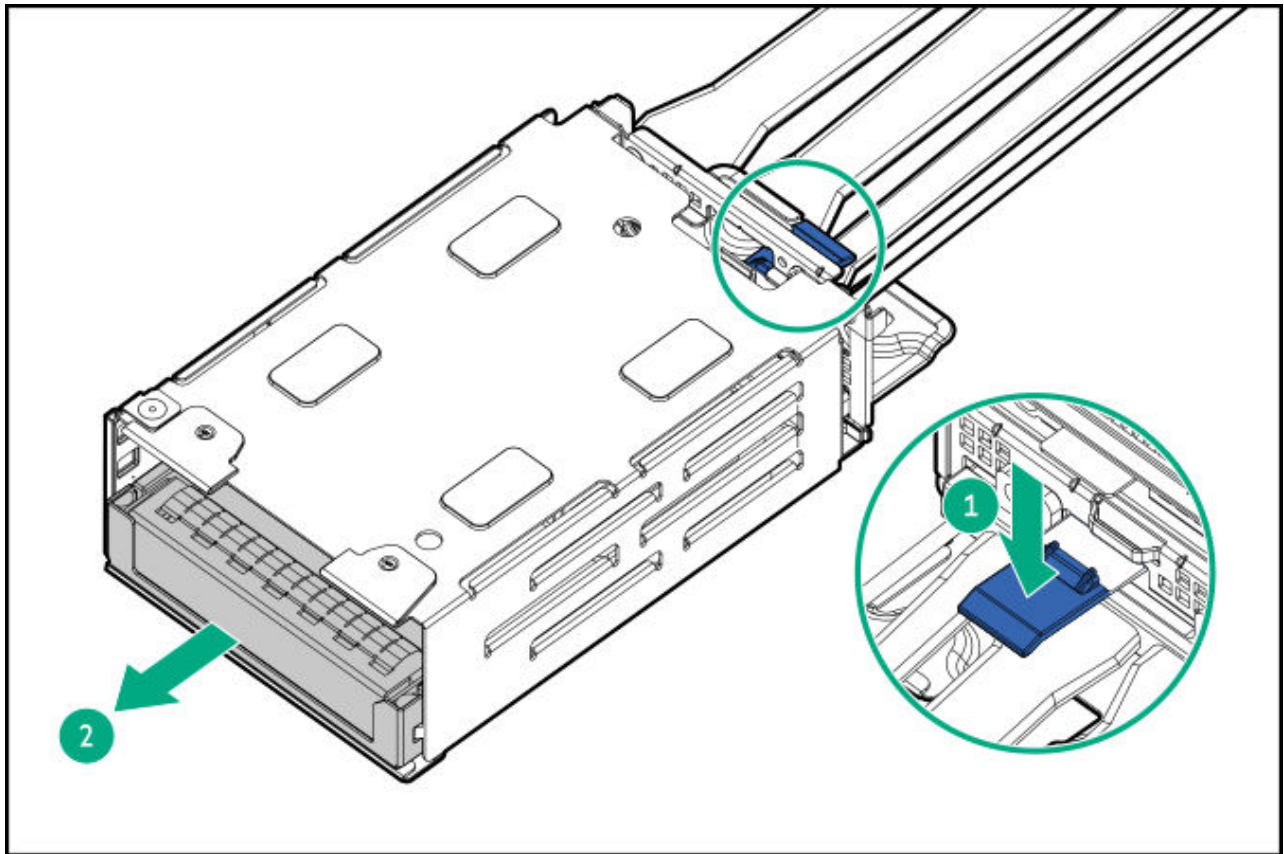

.0. Remove the OCP NIC bracket.



.1. Slide the OCP NIC out of the OCP NIC carrier.

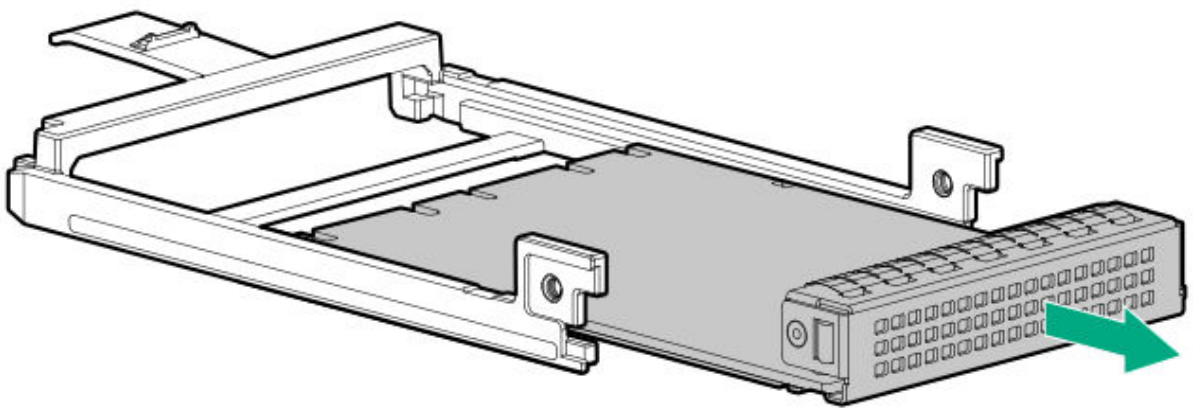

Results

The removal procedure is complete. To replace the component, reverse this procedure.

Removing and replacing the front OCP NIC cable

Prerequisites

Before you perform this procedure, make sure that you have a T-15 Torx screwdriver available.

About this task



CAUTION

A discharge of static electricity from a finger or other conductor might damage system boards or other static-sensitive devices. To prevent damage, observe [antistatic precautions](#).



CAUTION

To prevent improper cooling and thermal damage, do not operate the server unless all bays are populated with either a component or a blank.

Procedure

1. [Back up all server data](#).
2. [Power down the server](#).
3. If installed, [release the cable management arm](#).
4. Remove all power:
 - a. Disconnect each power cord from the power source.
 - b. Disconnect each power cord from the server.
5. Disconnect all peripheral cables from the server.
6. Do one of the following:
 - [Extend the server from the rack](#).
 - [Remove the server from the rack](#).
7. [Remove the access panel](#).
8. If installed, remove the air baffle.

An 8 SFF server is shown. The removal procedure is the same for all drive configurations.

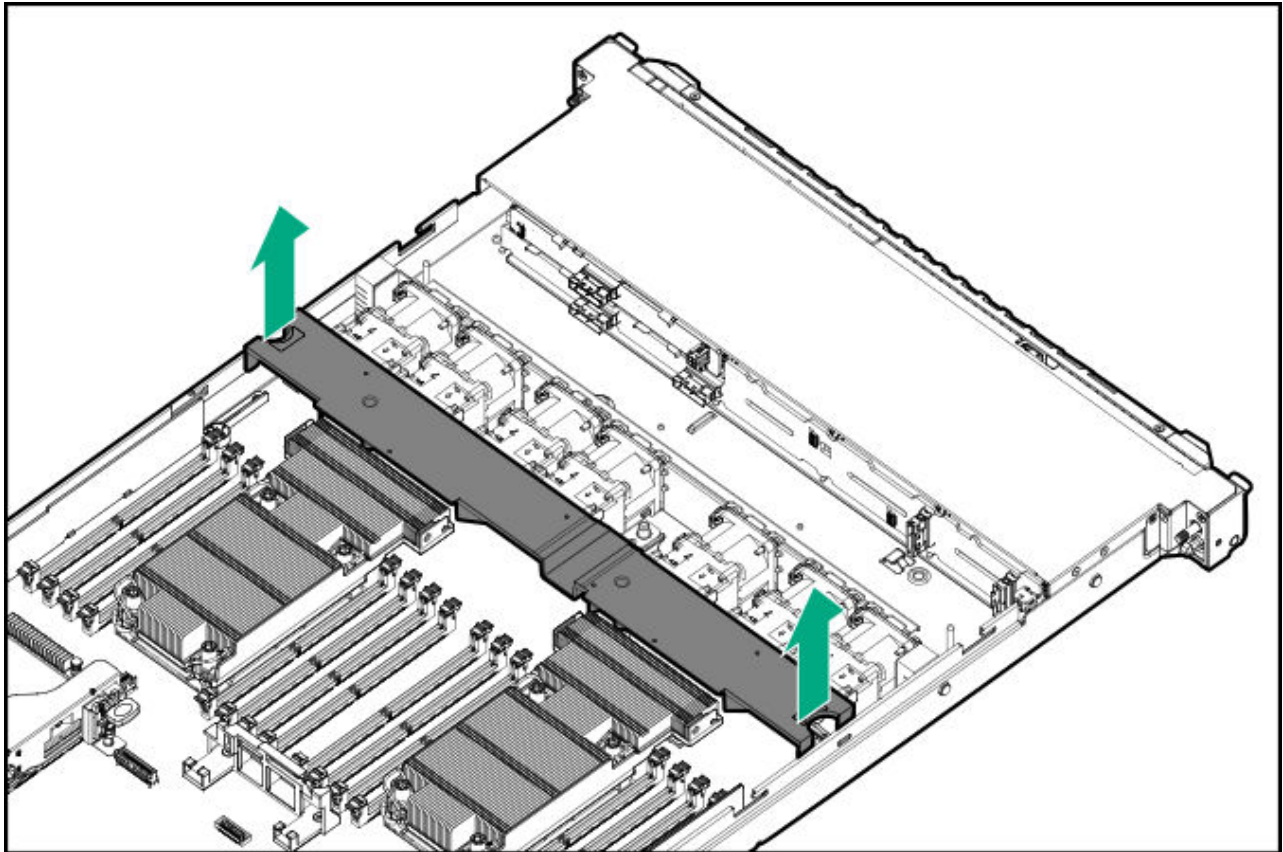

9. Remove the middle cover.
0. Disconnect the front OCP cable from the system board and the interposer.
- .1. Do the following:
 - a. Disconnect the front OCP NIC cable from the PHY board.
 - b. Remove the PHY board.



- .2. Remove the multipurpose cage.

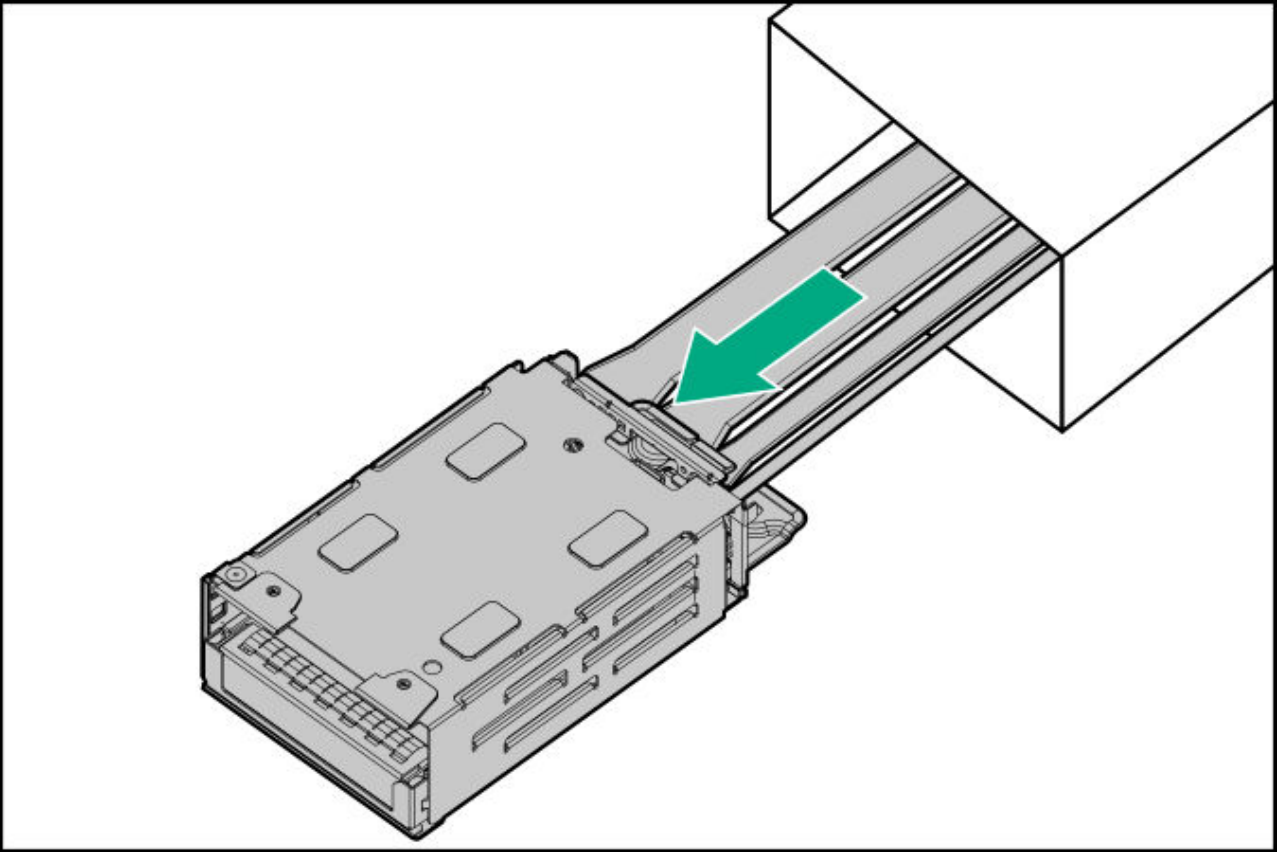

.3. Remove the OCP NIC.

.4. Remove the OCP NIC cable.

Bay 3 is shown. The removal procedures for Bay 1 and Bay 3 are similar.

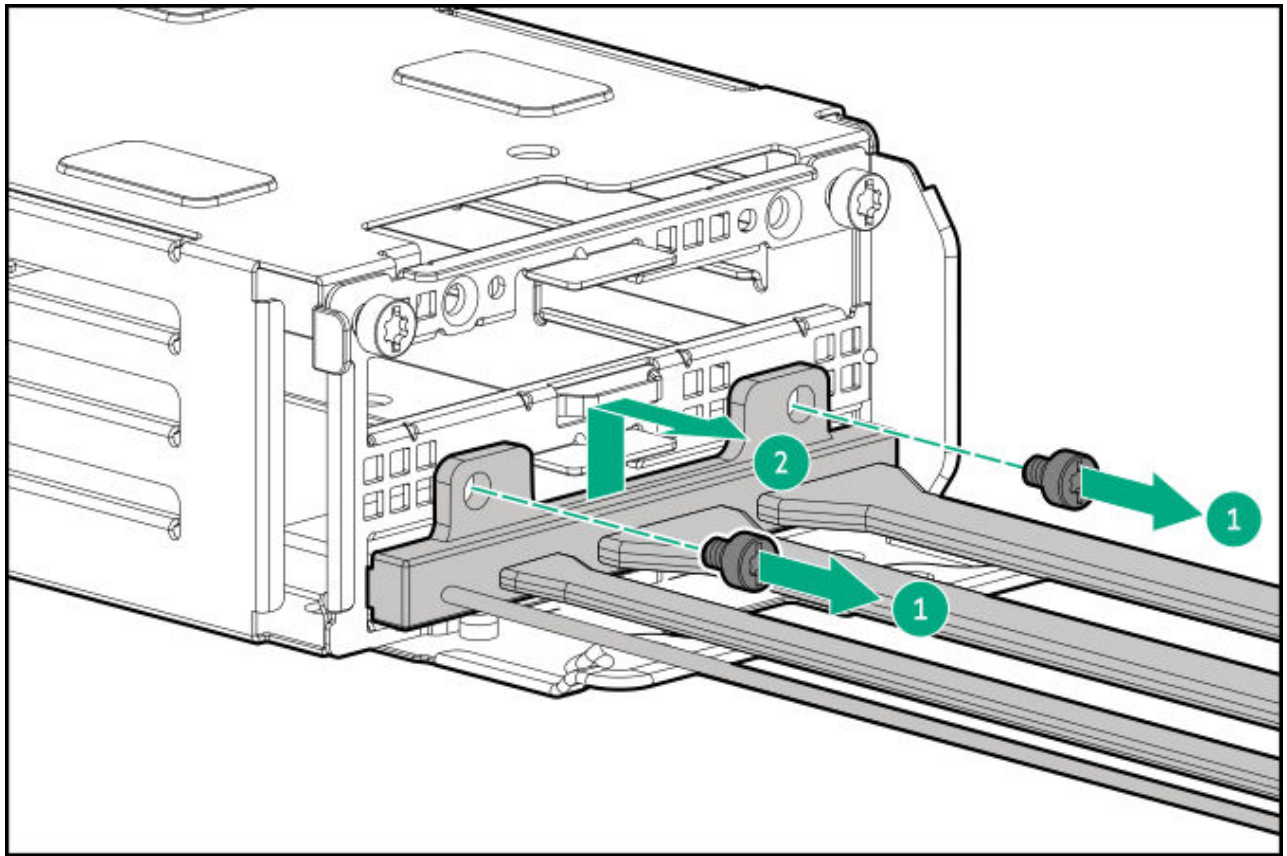

Results

The removal procedure is complete. To replace the component, reverse this procedure.

Removing and replacing the OCP NIC interposer

About this task



CAUTION

Before replacing a DIMM, backplane, expansion card, riser board, or other similar PCA components due to a perceived hardware error, make sure first that the component is firmly seated in the slot.

When installing the replacement component:

- Observe antistatic precautions.
- Handle the PCA only along the edges.
- Do not touch the components and connectors on the PCA.
- Do not bend or flex the PCA.



CAUTION

To prevent improper cooling and thermal damage, do not operate the server unless all OCP slots have either an OCP option or a slot blank installed.

Procedure

1. Back up all server data.
2. Power down the server.
3. If installed, release the cable management arm.
4. Remove all power:
 - a. Disconnect each power cord from the power source.
 - b. Disconnect each power cord from the server.
5. Disconnect all peripheral cables from the server.
6. Do one of the following:
 - Extend the server from the rack.
 - Remove the server from the rack.
7. Remove the access panel.
8. Remove the riser cages.

9. Do the following:

- Disconnect the front OCP NIC cable from the OCP NIC interposer
- Disconnect the Phy board cable from the OCP NIC interposer

10. Remove the OCP NIC interposer:

- a. Pivot the locking pin to the open (vertical) position.
- b. Push the blue touch point to disengage the interposer from the slot.
- c. Remove the interposer from the slot.

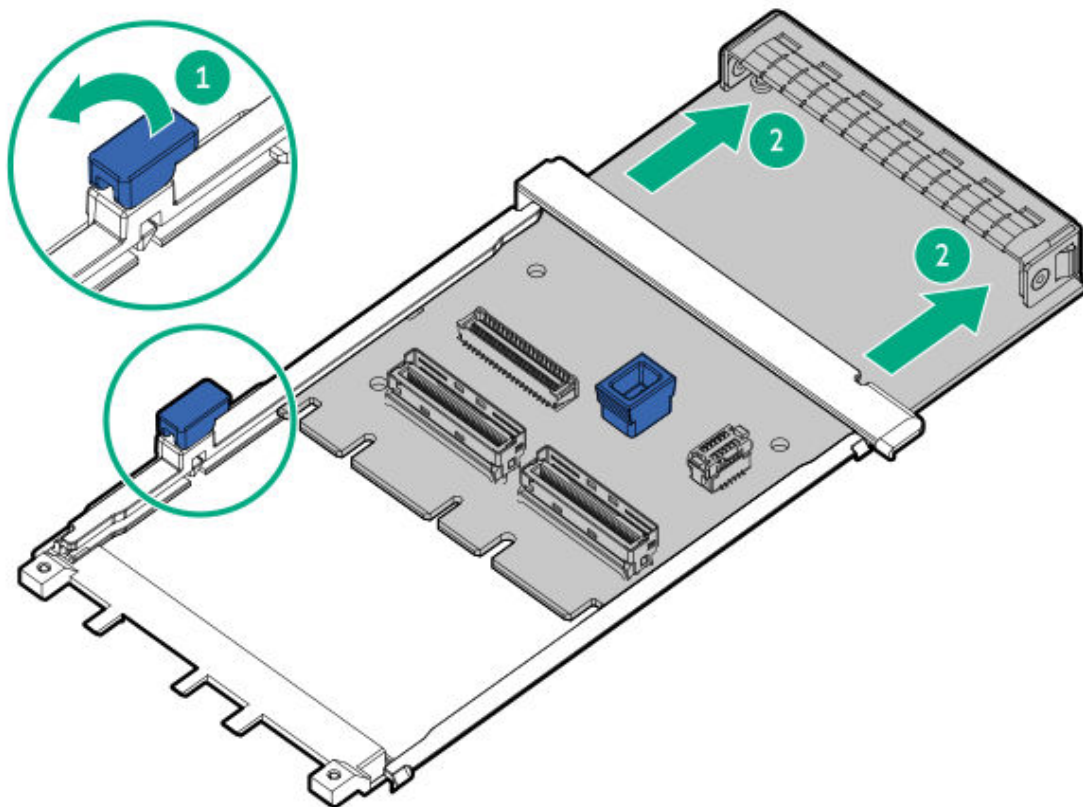

Results

The removal procedure is complete. To replace the component, reverse this procedure.

Fan replacement

Subtopics

Requirements for redundant fan support

Removing and replacing a fan

Removing and replacing a fan blank

Requirements for redundant fan support

The server must meet the minimum requirement for the number of functioning fan rotors to provide fan redundancy support. For the fan requirements, see the following table:

Fan configuration	Total number of rotors	Fan rotors required for redundancy	Fan rotors required for operation
7 standard fans (dual-rotor)	14	14	13
7 high performance fans (dual-rotor)			
5 standard fans (dual-rotor) *	10	10	9
7 liquid cooling fans (single-rotor)	7	7	6

* This is supported on servers using the one-processor configuration.

Removing and replacing a fan

Prerequisites

Before you perform this procedure, review the following:

- [Fan and heatsink requirements](#)
- [Requirements for redundant fan support](#)

About this task



CAUTION

Do not operate the server for long periods with the access panel open or removed. Operating the server in this manner results in improper airflow and improper cooling that can lead to thermal damage.



IMPORTANT

For optimum cooling, install fans in all primary fan locations.



IMPORTANT

The fan setup can either be all 7 of standard or high performance fans. Do not mix fan types in the same server.

Procedure

1. Extend the server from the rack.
2. Remove the access panel.
3. If installed, remove the air baffle.

An 8 SFF server is shown. The removal procedure is the same for all drive configurations.

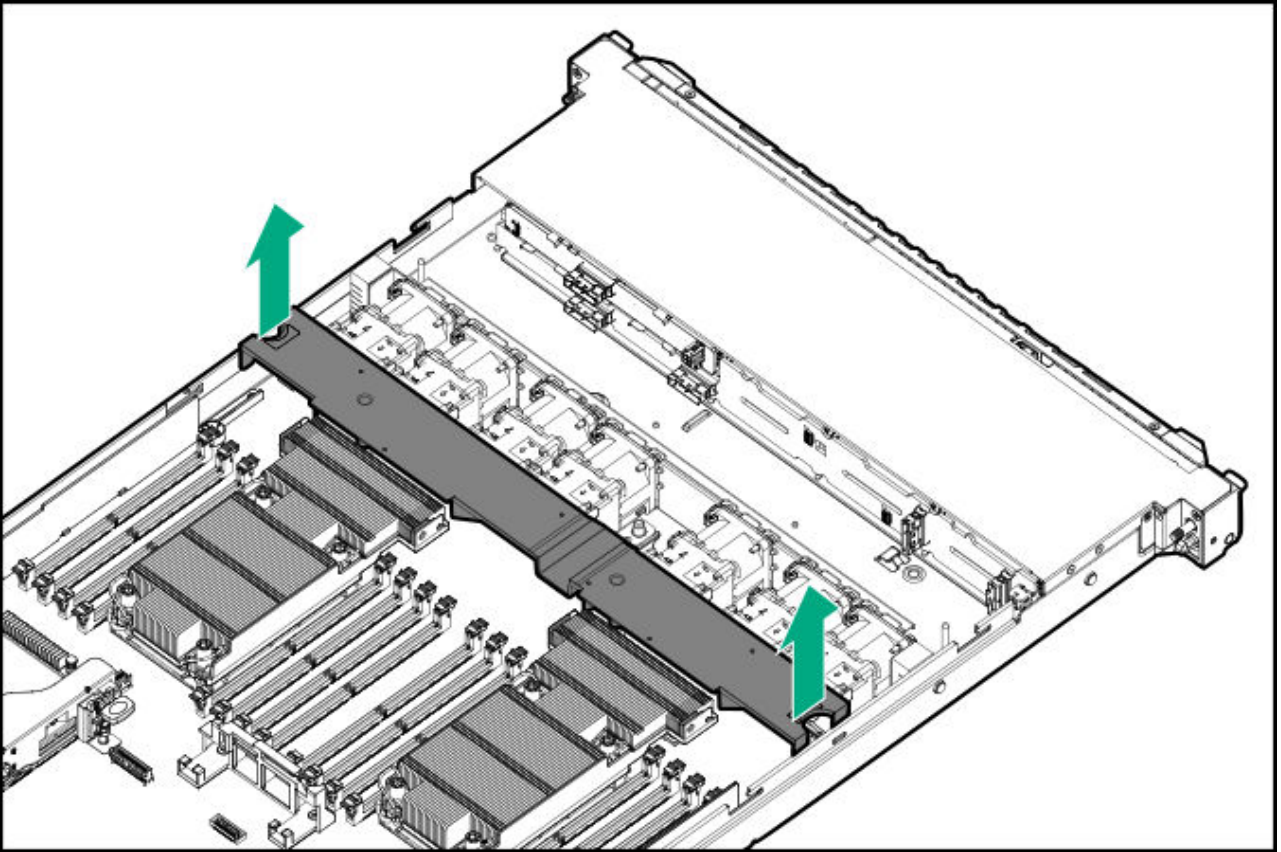

4. Remove the fan.



IMPORTANT

When a hot-plug fan is removed, the other fans in the server will increase speed to compensate.



CAUTION

To avoid server shutdown, a fan must be replaced within 60 seconds of being removed.

- Standard or high performance fan:

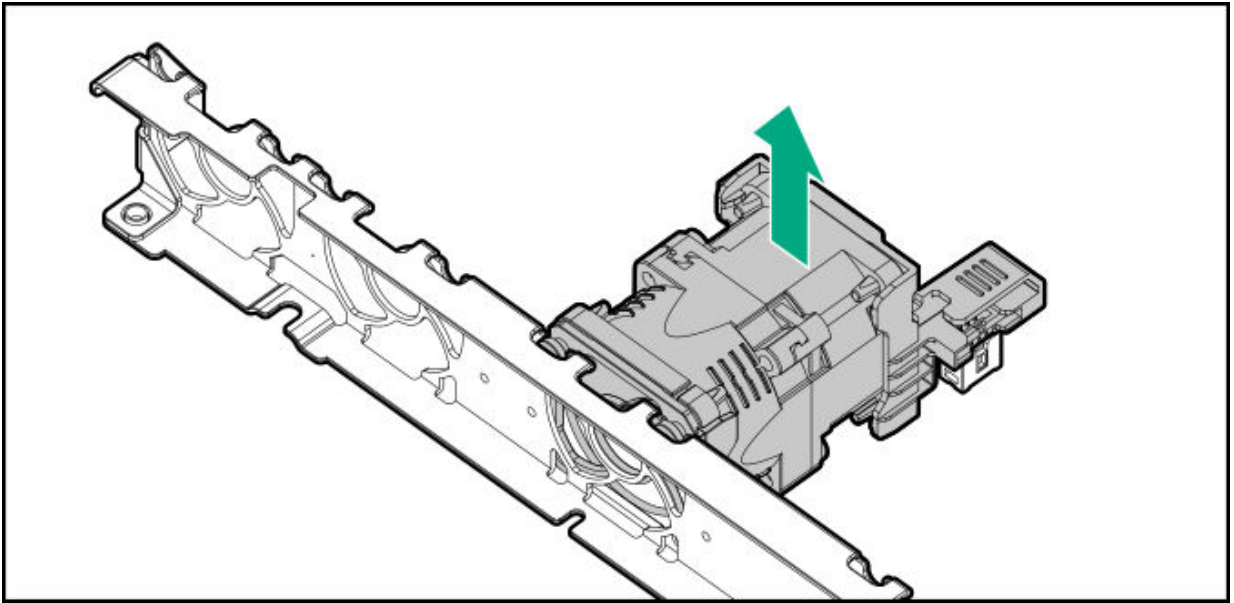

- Liquid cooling fan:

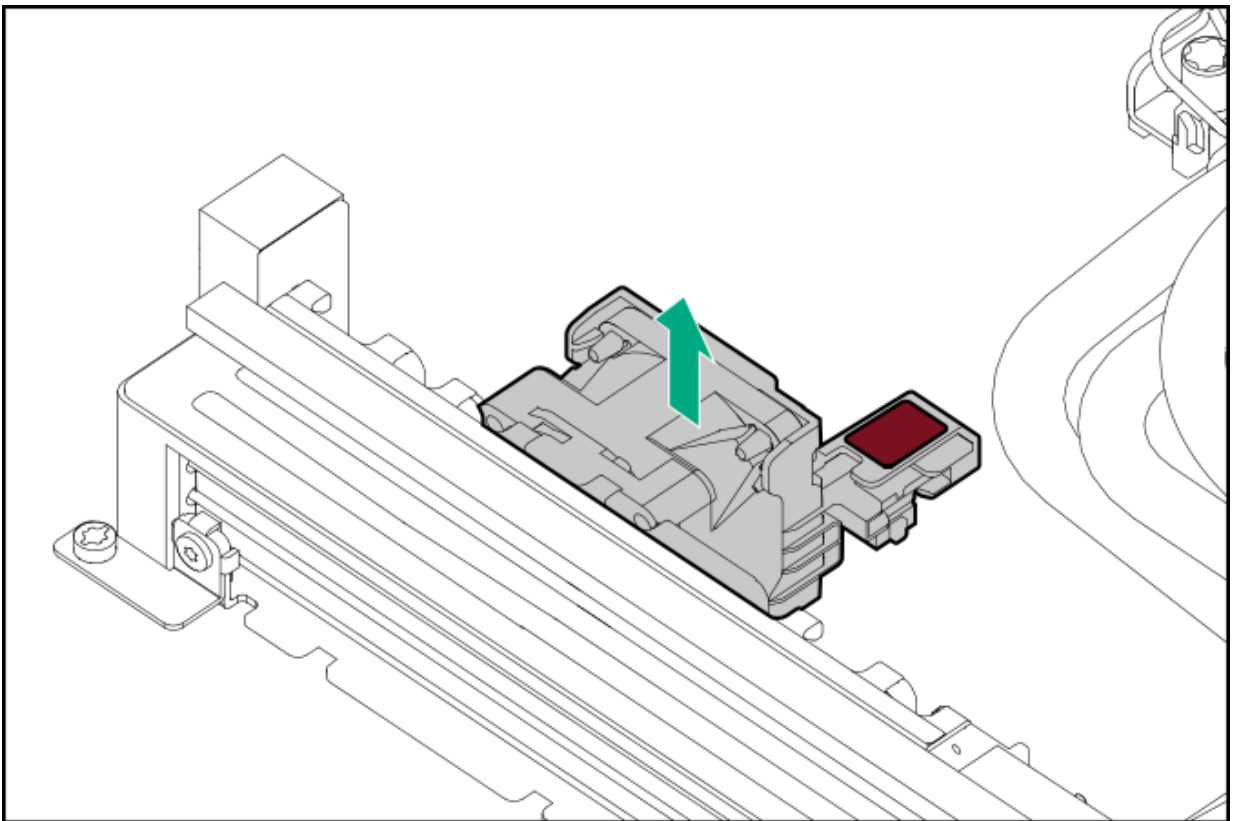

Results

The removal procedure is complete. To replace the component, reverse this procedure.

Removing and replacing a fan blank

About this task



CAUTION

Do not operate the server for long periods with the access panel open or removed. Operating the server in this manner results in improper airflow and improper cooling that can lead to thermal damage.



IMPORTANT

For optimum cooling, install fans in all primary fan locations.

Procedure

1. Extend the server from the rack.
2. Remove the access panel.
3. Remove the fan blank.

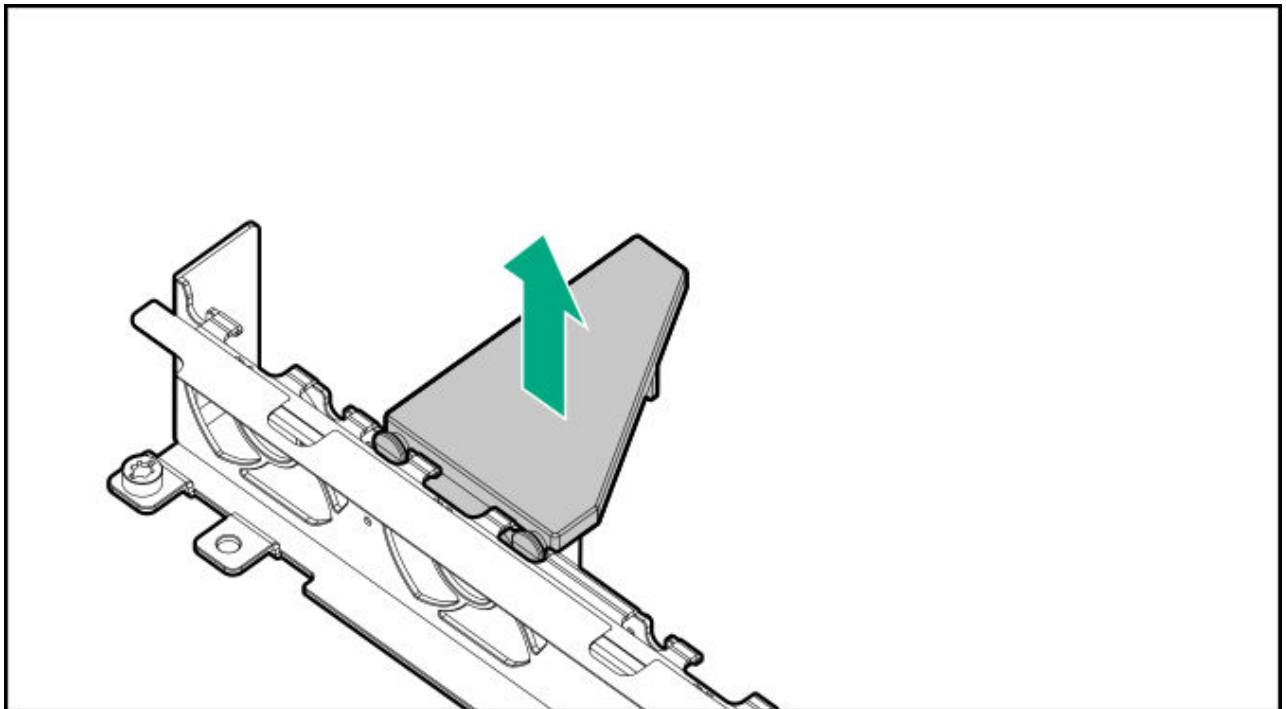

Results

To replace the component, reverse the removal procedure.

Removing and replacing the optical drive / DisplayPort / USB in the 4 LFF server

About this task



CAUTION

To prevent improper cooling and thermal damage, do not operate the server unless all bays are populated with either a component or a blank.



CAUTION

A discharge of static electricity from a finger or other conductor might damage system boards or other static-sensitive devices. To prevent damage, observe [antistatic precautions](#).

Procedure

1. [Power down the server](#).
2. Remove all power:
 - a. Disconnect each power cord from the power source.
 - b. Disconnect each power cord from the server.
3. Do one of the following:
 - [Extend the server from the rack](#).
 - [Remove the server from the rack](#).
4. [Remove the access panel](#).
5. [Disconnect the optical drive cable from the system board](#).
6. [Disconnect the display port/USB cable from the system board](#).
7. Remove the optical drive.

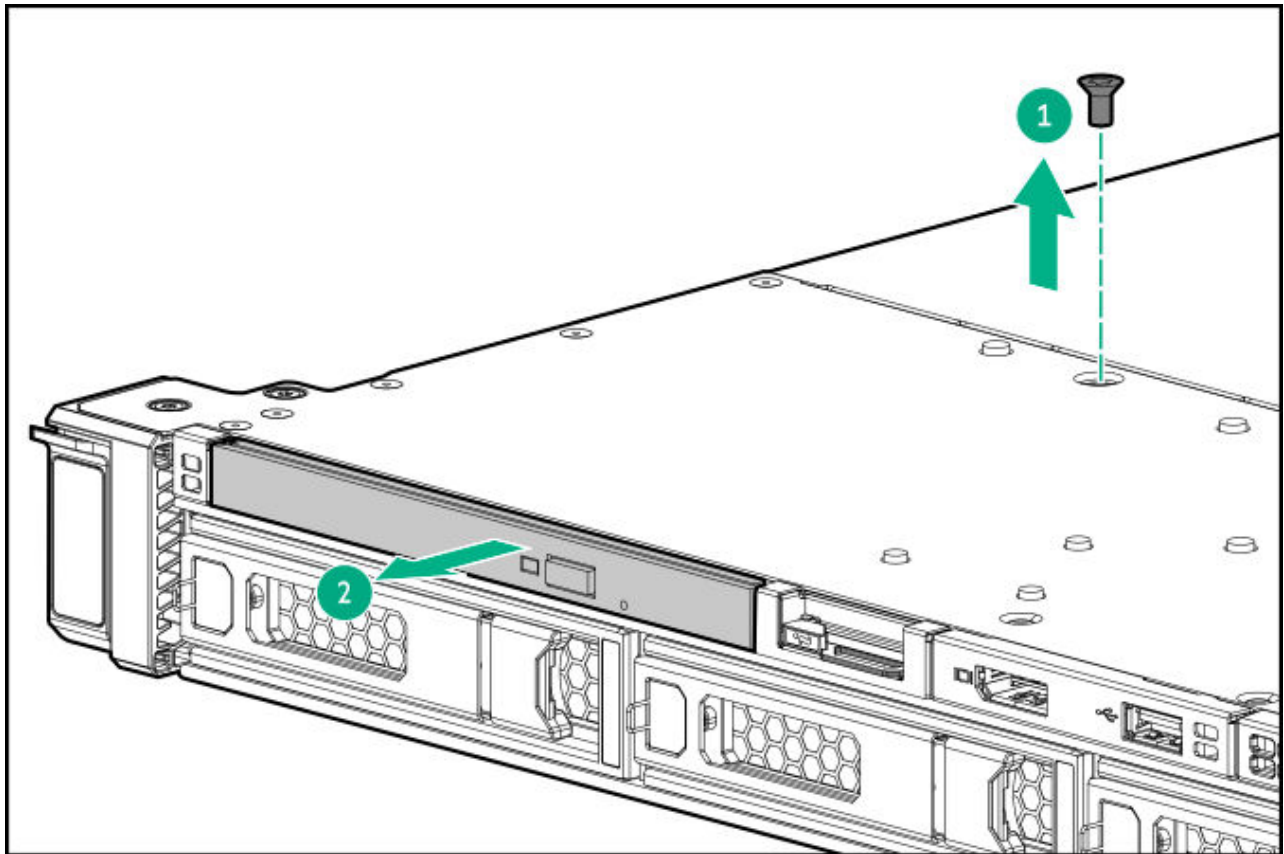

8. Remove the DisplayPort/USB.



Results

The removal procedure is complete. To replace the component, reverse this procedure.

Removing and replacing the DisplayPort / USB / optical drive in the 8 SFF server

Prerequisites

Before you perform this procedure, make sure that you have a T-15 Torx screwdriver available.

About this task



CAUTION

To prevent improper cooling and thermal damage, do not operate the server unless all bays are populated with either a component or a blank.



CAUTION

A discharge of static electricity from a finger or other conductor might damage system boards or other static-sensitive devices. To prevent damage, observe antistatic precautions.

Procedure

1. Power down the server.
2. Remove all power:
 - a. Disconnect each power cord from the power source.
 - b. Disconnect each power cord from the server.
3. Do one of the following:
 - a. Extend the server from the rack.
 - b. Remove the server from the rack.
4. Remove the access panel.
5. Do the following:
 - Disconnect the DisplayPort / USB cable from the system board.
 - If installed, disconnect the optical drive cable from the system board and optical drive.
6. Remove the component.

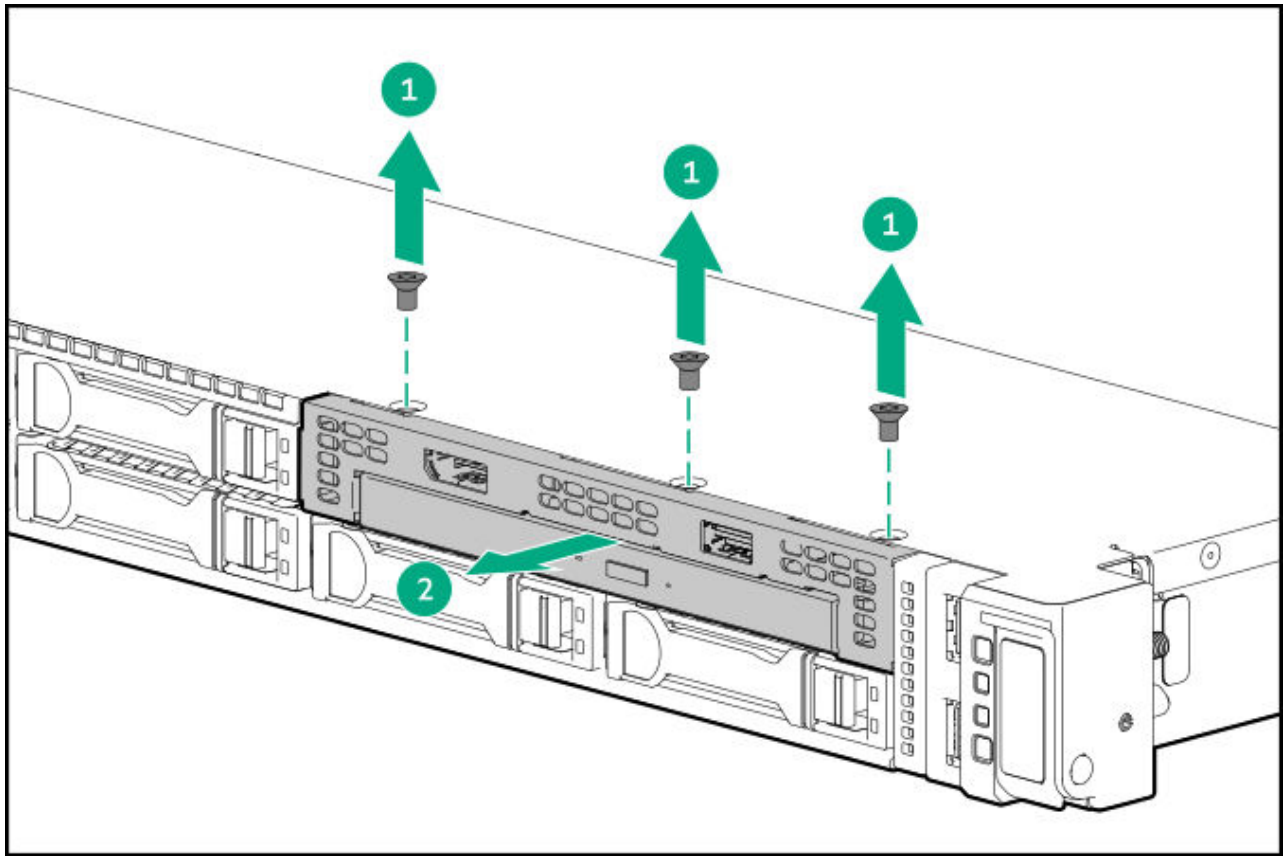

7. If installed, remove the optical drive.

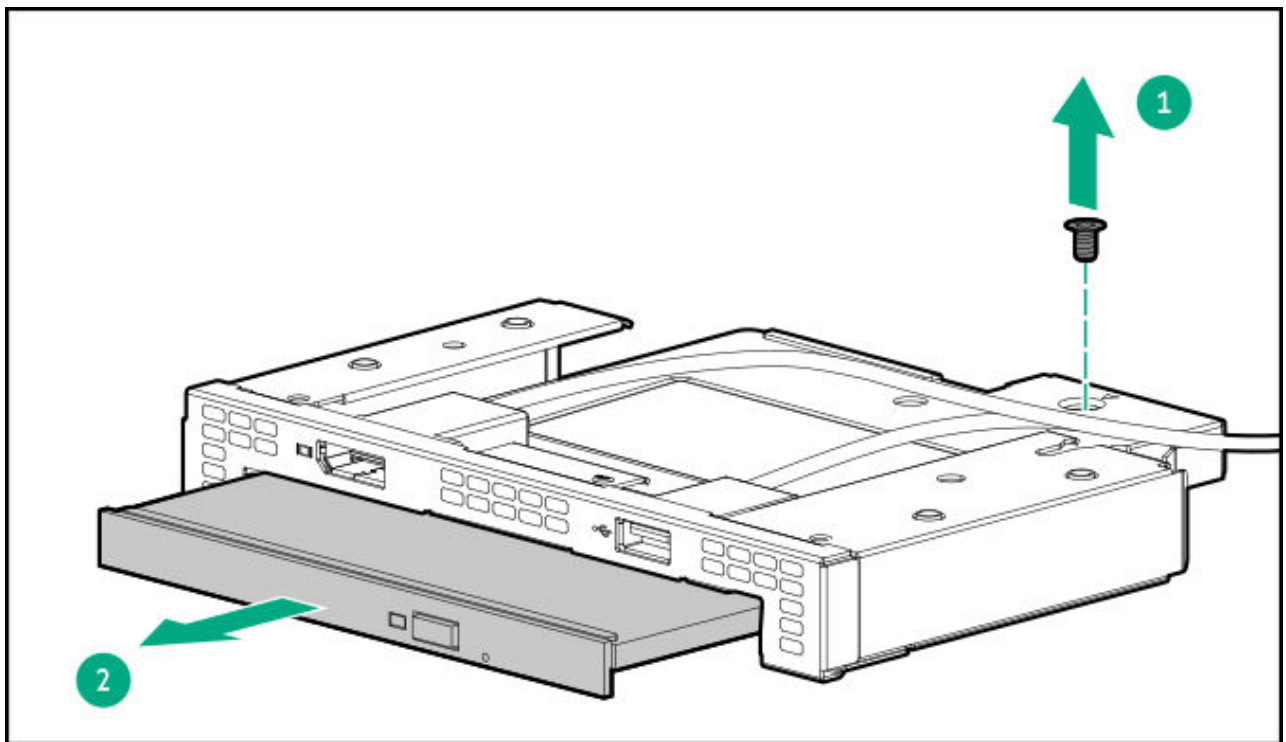

Results

The removal procedure is complete. To replace the component, reverse this procedure.

Removing and replacing a DisplayPort / USB / optical drive in drive boxes 4–5

Prerequisites

Before you perform this procedure, make sure that you have the following items available:

- T-10 Torx screwdriver
- T-15 Torx screwdriver

About this task



CAUTION

To prevent improper cooling and thermal damage, do not operate the server unless all bays are populated with either a component or a blank.



CAUTION

A discharge of static electricity from a finger or other conductor might damage system boards or other static-sensitive devices. To prevent damage, observe [antistatic precautions](#).

Procedure

1. [Power down the server](#).
2. Remove all power:
 - a. Disconnect each power cord from the power source.
 - b. Disconnect each power cord from the server.
3. Do one of the following:
 - a. [Extend the server from the rack](#).
 - b. [Remove the server from the rack](#).
4. [Remove the access panel](#).
5. [Remove the middle cover](#).

6. Disconnect the DisplayPort/USB cable from the system board.
7. If installed, disconnect the optical drive cable from the system board and optical drive.
8. Remove the component.



9. If installed, remove the optical drive.

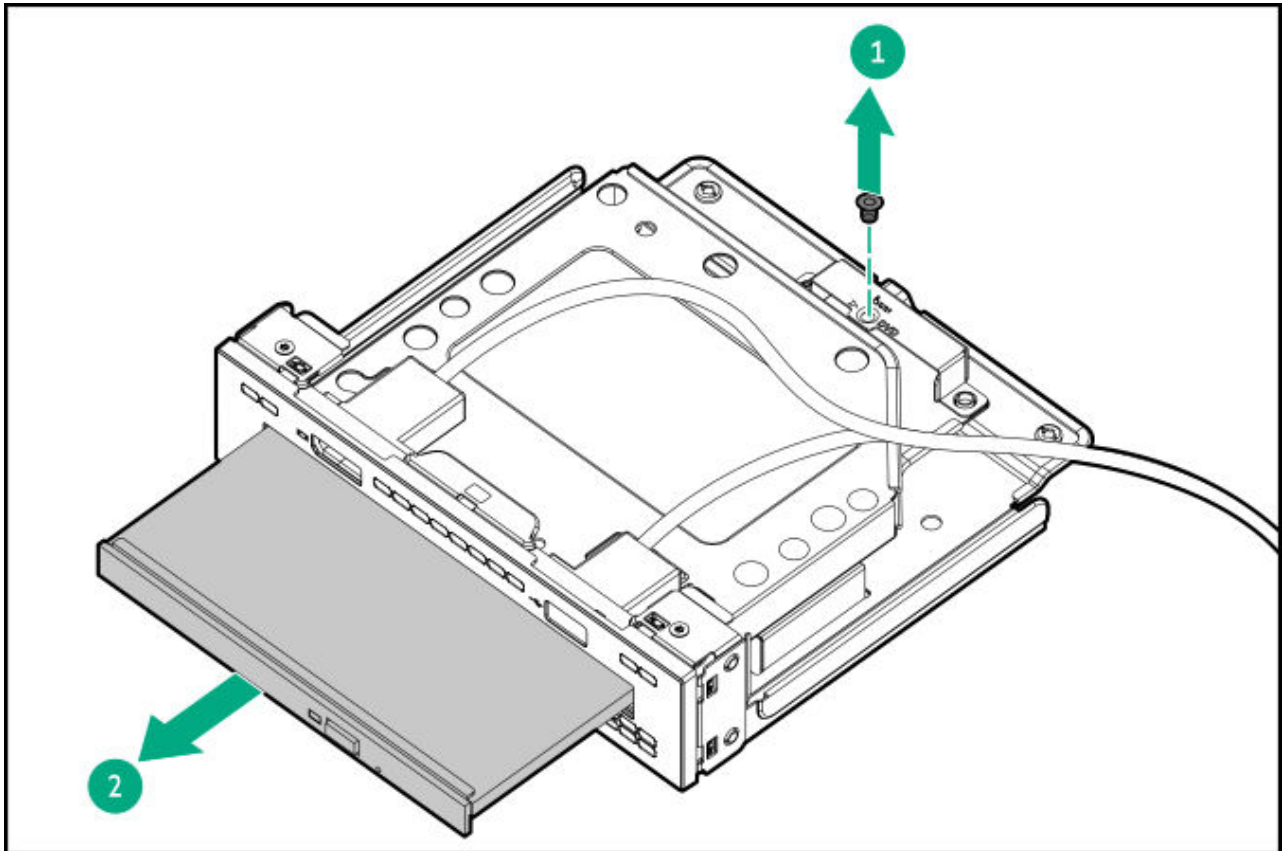

Results

The removal procedure is complete. To replace the component, reverse this procedure.

Drive backplane replacement

Subtopics

Removing and replacing the 4 LFF drive backplane

Removing and replacing the 8 SFF drive backplane

Removing and replacing the 2 SFF drive backplane in the 8 + 2 SFF drive configuration

Removing and replacing the stacked 2 SFF / 4 E3.S drive backplane in the 10 SFF / 20 E3.S server

Removing and replacing the 4 LFF drive backplane

Prerequisites

Before you perform this procedure, make sure that you have a T-15 Torx screwdriver available.

About this task

https://sketchfab.com/models/6e429b876c674072af9b4d964e7c2919/embed?ui_infos=0&ui_watermark=0&ui_help=0&ui_vr=0&ui_settings=0&ui_inspector=0&ui_hint=2&ui_color=01a982&ui_theme=dark&autostart=1&camera=0&



CAUTION

Before replacing a DIMM, backplane, expansion card, riser board, or other similar PCA components due to a perceived hardware error, make sure first that the component is firmly seated in the slot.

When installing the replacement component:

- Observe antistatic precautions.
- Handle the PCA only along the edges.
- Do not touch the components and connectors on the PCA.
- Do not bend or flex the PCA.

Procedure

1. Back up all server data.
2. If installed, remove the front bezel.
3. Power down the server.
4. Remove all power:
 - a. Disconnect each power cord from the power source.
 - b. Disconnect each power cord from the server.

5. Do one of the following:
 - a. Extend the server from the rack.
 - b. Remove the server from the rack.
6. Remove the access panel.
7. Remove all drives and drive blanks.
Note where each drive is located.
8. If installed, remove the Smart Storage Battery.
9. Disconnect all cables from the drive backplane.
10. Remove the drive backplane.

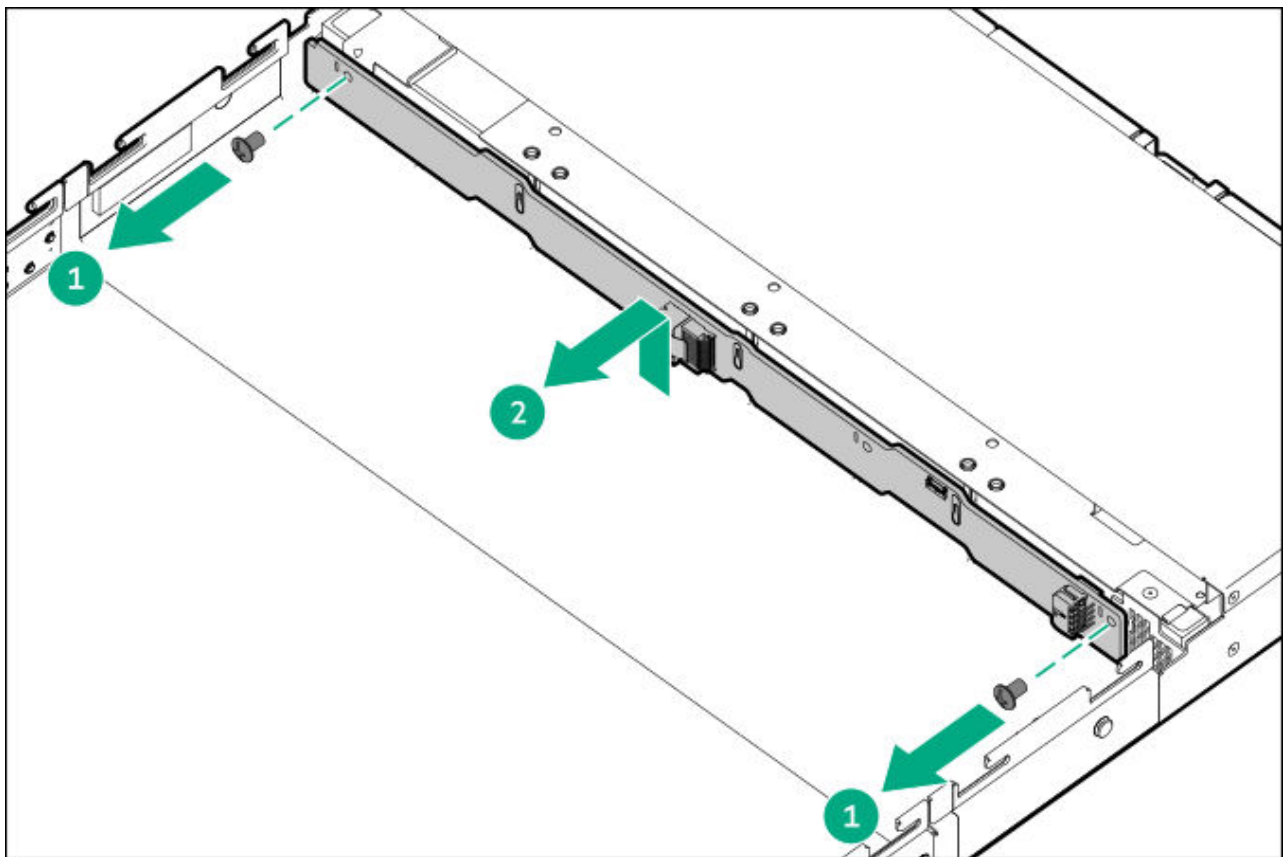

Results

The removal procedure is complete. To replace the component, reverse this procedure.

Removing and replacing the 8 SFF drive backplane

About this task

https://sketchfab.com/models/10076a77c0c244c5a8f5d783e4cbd90b/embed?ui_infos=0&ui_watermark=0&ui_help=0&ui_vr=0&ui_settings=0&ui_inspector=0&ui_hint=2&ui_color=01a982&ui_theme=dark&autostart=1&camera=0&



CAUTION

Before replacing a DIMM, backplane, expansion card, riser board, or other similar PCA components due to a perceived hardware error, make sure first that the component is firmly seated in the slot.

When installing the replacement component:

- Observe antistatic precautions.
- Handle the PCA only along the edges.
- Do not touch the components and connectors on the PCA.
- Do not bend or flex the PCA.

Procedure

1. Back up all server data.
2. If installed, remove the front bezel.
3. Power down the server.
4. Remove all power:
 - a. Disconnect each power cord from the power source.
 - b. Disconnect each power cord from the server.
5. Do one of the following:
 - a. Extend the server from the rack.
 - b. Remove the server from the rack.
6. Remove the access panel.
7. Remove all drives and drive blanks.

Note where each drive is located.

8. If installed, remove the Smart Storage Battery.
9. Disconnect and remove all cables from the drive backplane.
10. Remove the drive backplane.

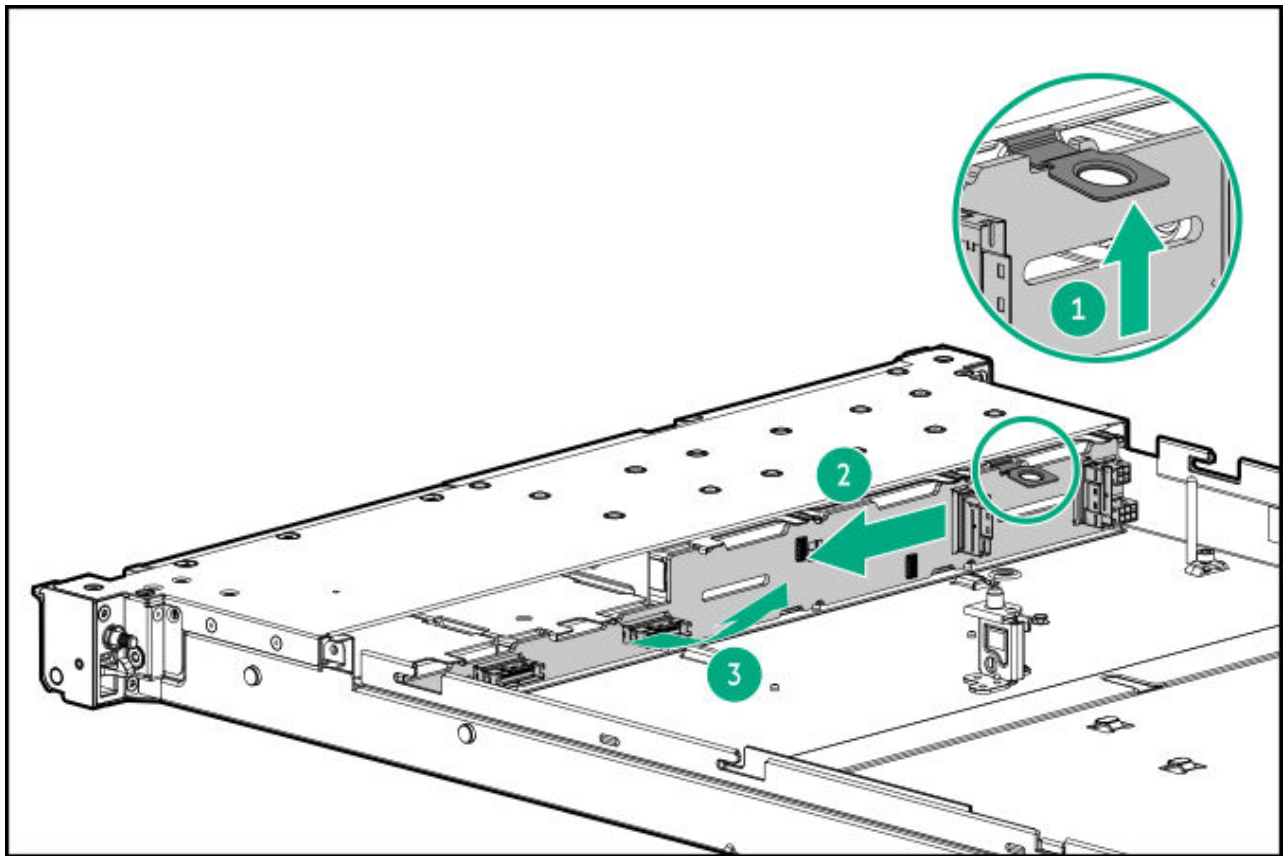

Results

The removal procedure is complete. To replace the component, reverse this procedure.

Removing and replacing the 2 SFF drive backplane in the 8 + 2 SFF drive configuration

About this task

<https://sketchfab.com/models/dc0184fdd0c7413bbaf526de160f5556/embed?>



CAUTION

Before replacing a DIMM, backplane, expansion card, riser board, or other similar PCA components due to a perceived hardware error, make sure first that the component is firmly seated in the slot.

When installing the replacement component:

- Observe antistatic precautions.
- Handle the PCA only along the edges.
- Do not touch the components and connectors on the PCA.
- Do not bend or flex the PCA.

Procedure

1. Back up all server data.
2. If installed, remove the front bezel.
3. Power down the server.
4. Remove all power:
 - a. Disconnect each power cord from the power source.
 - b. Disconnect each power cord from the server.
5. Do one of the following:
 - a. Extend the server from the rack.
 - b. Remove the server from the rack.
6. Remove the access panel.
7. Remove all drives and drive blanks.

Note where each drive is located.
8. If installed, remove the Smart Storage Battery.
9. Disconnect and remove all cables from the drive backplane.
10. Remove the drive backplane.

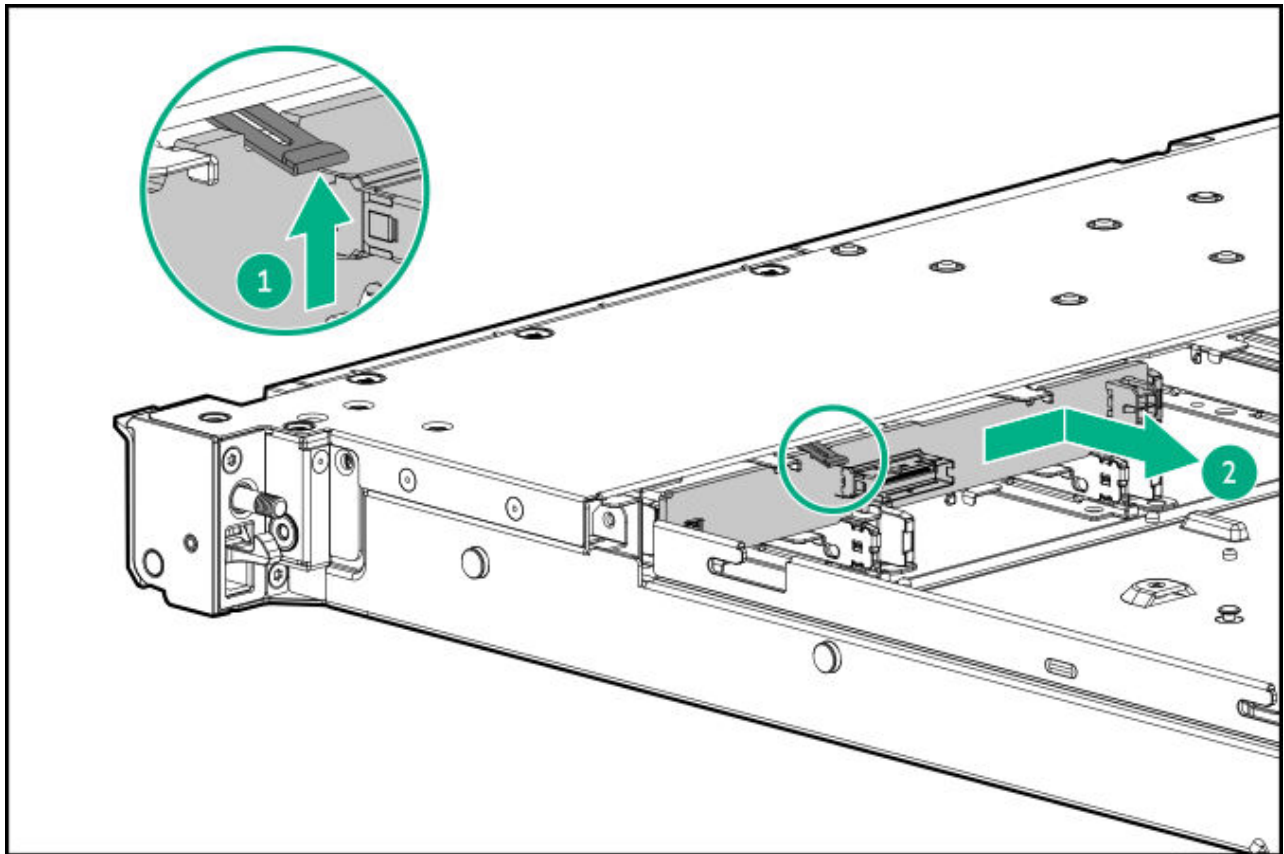

Results

The removal procedure is complete. To replace the component, reverse this procedure.

Removing and replacing the stacked 2 SFF / 4 E3.S drive backplane in the 10 SFF / 20 E3.S server

Prerequisites

Before you perform this procedure, make sure that you have a T-10 Torx screwdriver available.

About this task

https://sketchfab.com/models/989cb6d1a1b64442b9d9dd8d831d437b/embed?ui_infos=0&ui_watermark=0&ui_help=0&ui_vr=0&ui_settings=0&ui_inspector=0&ui_hint=2&ui_color=01a982&ui_theme=dark&autostart=1&camera=0&

A drive cage must be installed in drive box 1 to support the installation of the serial number/iLO information pull tab.



CAUTION

Before replacing a DIMM, backplane, expansion card, riser board, or other similar PCA components due to a perceived hardware error, make sure first that the component is firmly seated in the slot.

When installing the replacement component:

- Observe antistatic precautions.
- Handle the PCA only along the edges.
- Do not touch the components and connectors on the PCA.
- Do not bend or flex the PCA.

Procedure

1. Back up all server data.
2. If installed, remove the front bezel.
3. Power down the server.
4. Remove all power:
 - a. Disconnect each power cord from the power source.
 - b. Disconnect each power cord from the server.
5. Do one of the following:
 - a. Extend the server from the rack.
 - b. Remove the server from the rack.
6. Remove the access panel.
7. Remove all drives and drive blanks from the drive box.

Note where each drive is located.
8. If installed, remove the Smart Storage Battery.
9. Disconnect and remove all cables from the drive backplane.
 - 2 SFF drive backplane
 - 4 E3.S drive backplane

.0. Remove the drive cage from the server.

- 2 SFF drive cage

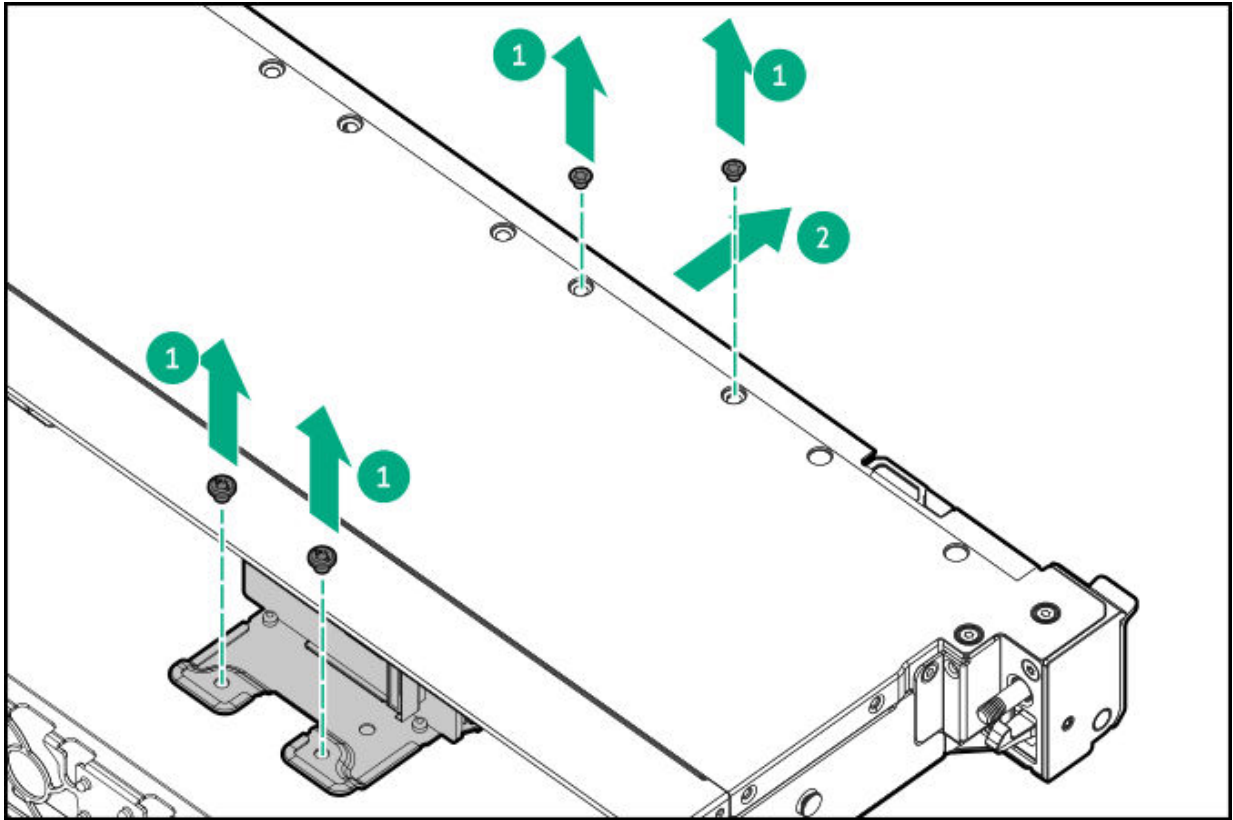

- 4 E3.S drive cage

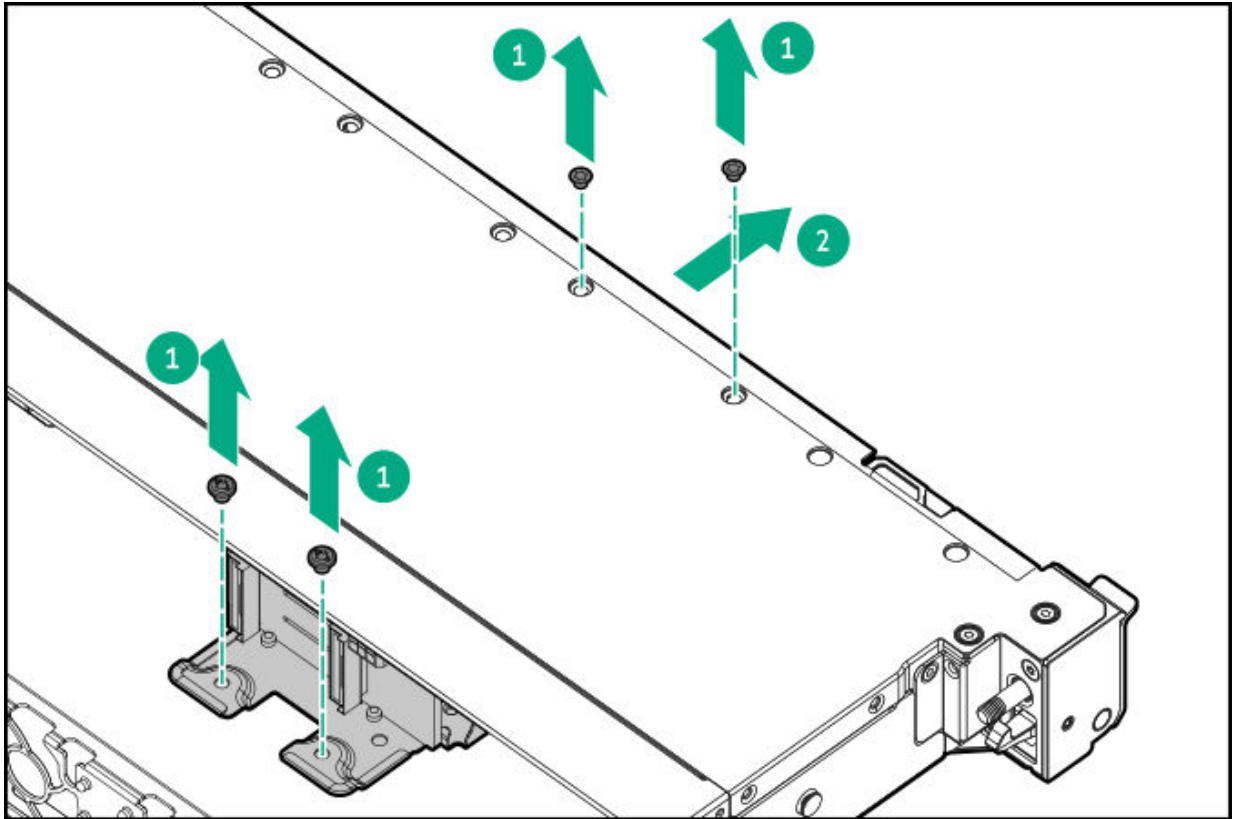

.1. Remove the drive backplane from the drive cage.

- 2 SFF drive backplane

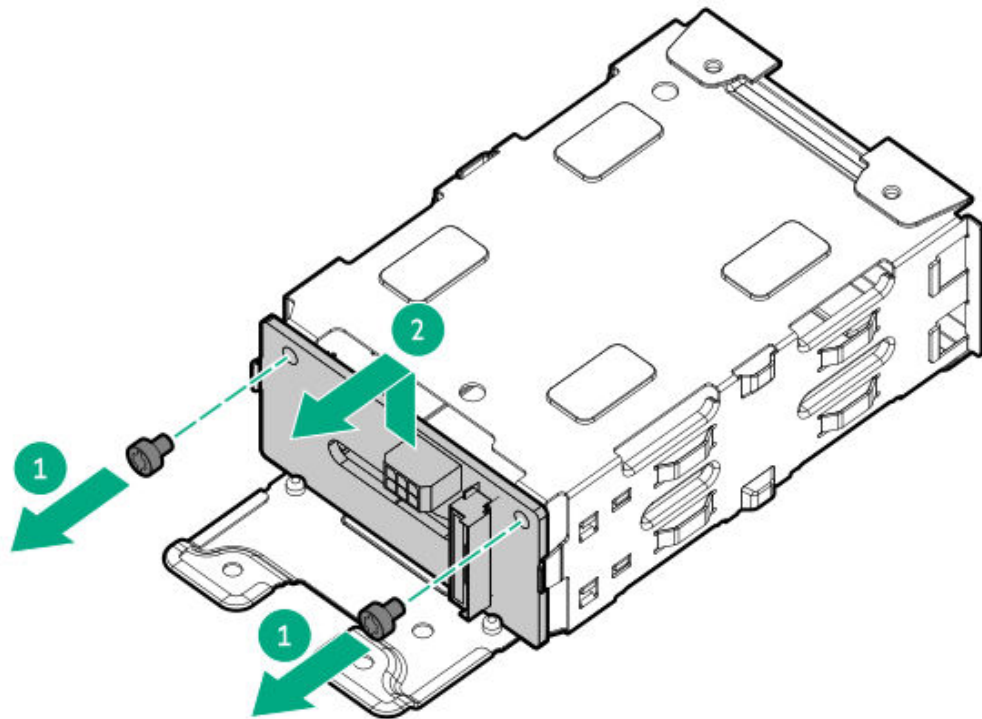

- 4 E3.S drive backplane



Results

The removal procedure is complete. To replace the component, reverse this procedure.

Removing and replacing an energy pack

About this task

<https://sketchfab.com/models/2b1ad8674b5f4c8dad1b70200ee64ad0/embed?>



CAUTION

A discharge of static electricity from a finger or other conductor might damage system boards or other static-sensitive devices. To prevent damage, observe antistatic precautions.



NOTE

System ROM and firmware messages might display "energy pack" in place of "Smart Storage Battery." Energy pack refers to both HPE Smart Storage batteries and HPE Smart Storage Hybrid capacitors.

Procedure

1. Power down the server.
2. Remove all power:
 - a. Disconnect each power cord from the power source.
 - b. Disconnect each power cord from the server.
3. Disconnect all peripheral cables from the server.
4. Do one of the following:
 - a. Extend the server from the rack.
 - b. Remove the server from the rack.
5. Place the server on a flat, level work surface.
6. Remove the access panel.
7. Disconnect the cable and then remove the battery or capacitor pack.

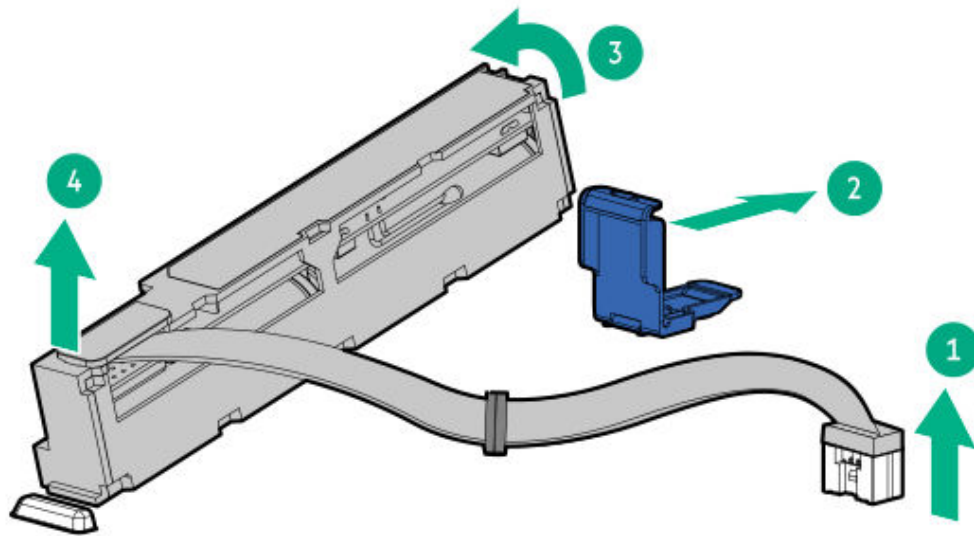

When removing the cable, remove the cable and cable extender.

8. Disconnect the cable extender from the energy pack.

Retain the cable extender. The cable extender will be used to install the new energy pack spare to the system board.

Results

The removal procedure is complete. To replace the component, reverse this procedure.

Removing and replacing the energy pack retention latch

About this task



CAUTION

A discharge of static electricity from a finger or other conductor might damage system boards or other static-sensitive devices. To prevent damage, observe antistatic precautions.

Procedure

1. Power down the server.
2. Remove all power:
 - a. Disconnect each power cord from the power source.

- b. Disconnect each power cord from the server.
3. Disconnect all peripheral cables from the server.
4. Do one of the following:
 - a. Extend the server from the rack.
 - b. Remove the server from the rack.
5. Place the server on a flat, level work surface.
6. Remove the access panel.
7. If the energy pack is installed, do the following:
 - a. Disconnect the energy pack power extension cable from the system board.
 - b. Remove the energy pack.

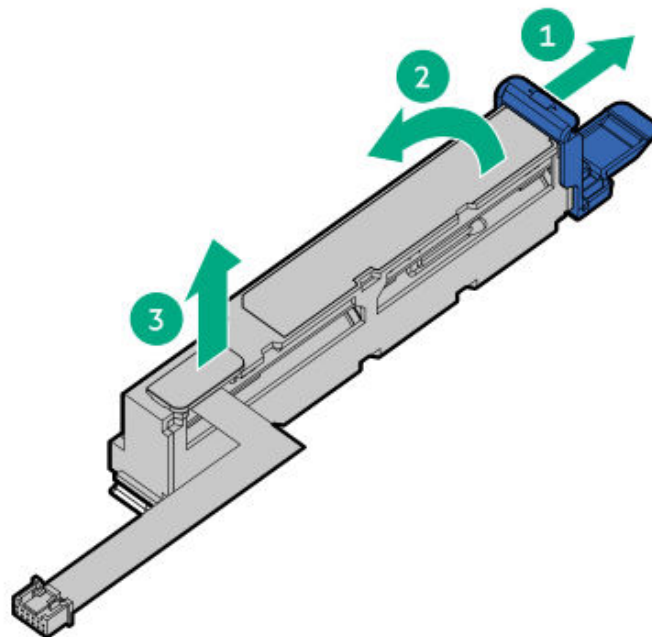

8. Remove the energy pack retention latch:
 - a. Pull up and hold the latch.
 - b. Push the latch to detach from the chassis.

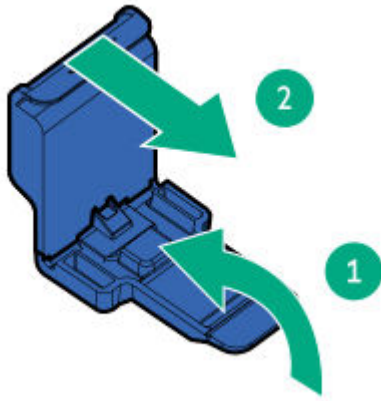

Results

The removal procedure is complete. To replace the component, reverse this procedure.

Removing and replacing a DIMM

Prerequisites

Before you perform this procedure, review the:

- Memory configuration and installation guidelines in the server user guide (<https://www.hpe.com/info/dl360gen12-ug>)
- [DIMM slot locations](#)

About this task

<https://sketchfab.com/models/ec39e4183f8f410e93c8c34a1611b560/embed?>



CAUTION

Before replacing a DIMM, backplane, expansion card, riser board, or other similar PCA components due to a perceived hardware error, make sure first that the component is firmly seated in the slot.

When installing the replacement component:

- Observe antistatic precautions.
- Handle the PCA only along the edges.
- Do not touch the components and connectors on the PCA.
- Do not bend or flex the PCA.

Procedure

1. Power down the server.
2. Remove all power:
 - a. Disconnect each power cord from the power source.
 - b. Disconnect each power cord from the server.
3. Do one of the following:
 - a. Extend the server from the rack.
 - b. Remove the server from the rack.
4. Place the server on a flat, level work surface.
5. Remove the access panel.
6. Remove the DIMM.

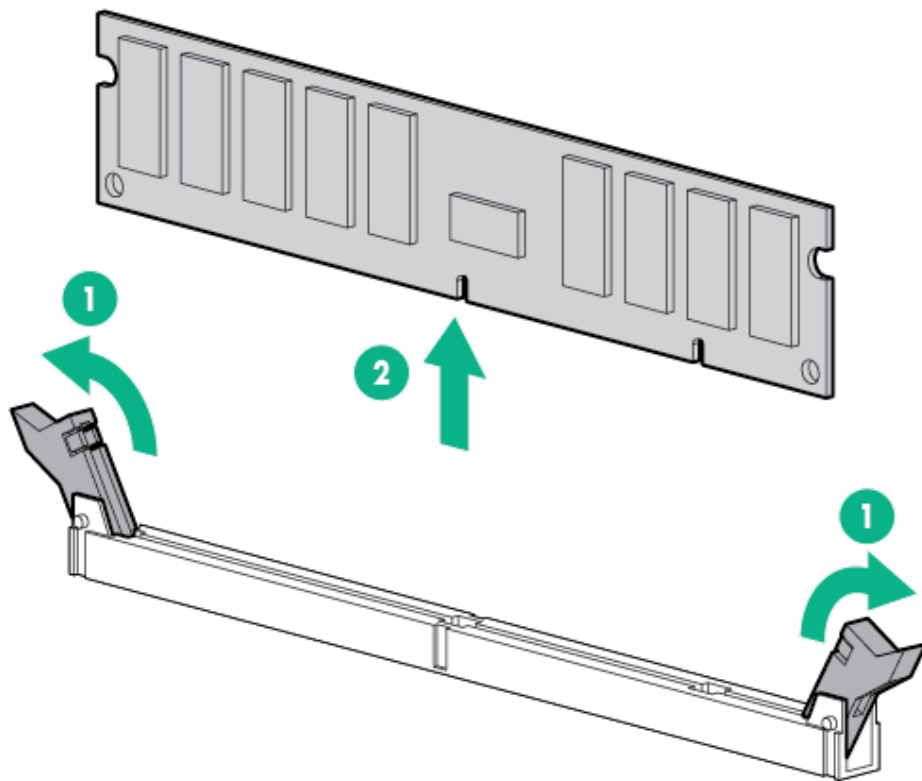

Results

The removal procedure is complete. To replace the component, reverse this procedure.

Removing and replacing a DIMM blank

About this task



CAUTION

To prevent improper cooling and thermal damage, do not operate the server unless all DIMM slots have either a DIMM or a DIMM blank installed.

Procedure

1. Power down the server.
2. If installed, release the cable management arm.
3. Remove all power:

- a. Disconnect each power cord from the power source.
- b. Disconnect each power cord from the server.
4. Disconnect all peripheral cables from the server.
5. Do one of the following:
 - a. Extend the server from the rack.
 - b. Remove the server from the rack.
6. Place the server on a flat, level work surface.
7. Remove the access panel.
8. Remove the DIMM blank.

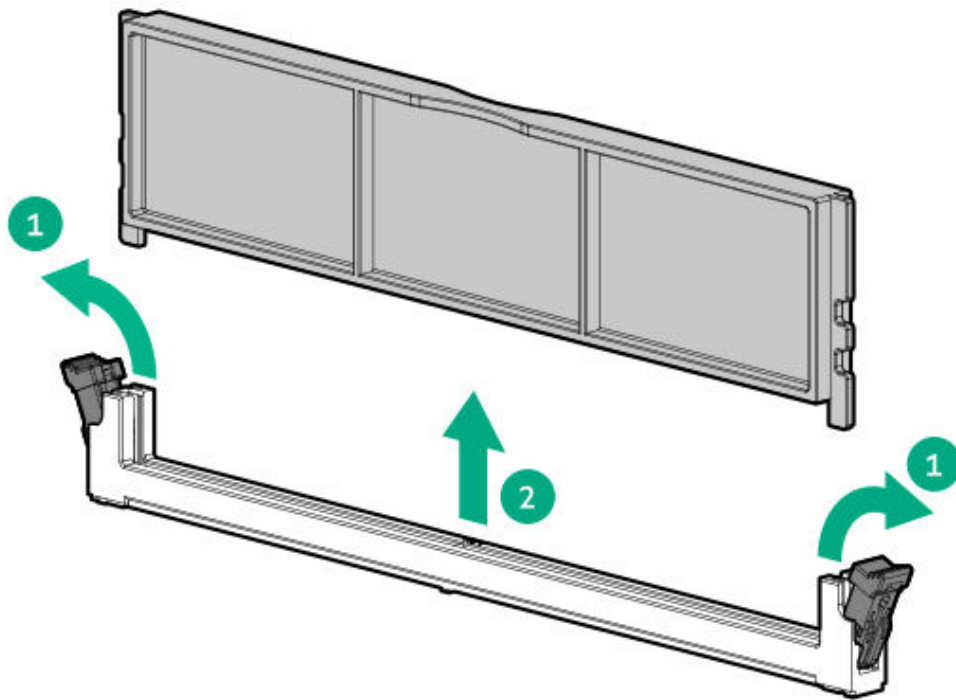

Results

The removal procedure is complete. To replace the component, reverse this procedure.

Removing and replacing a riser cage

About this task

Primary riser cage

https://sketchfab.com/models/6eb76f4676ee4118a9950412db0460c4/embed?ui_infos=0&ui_watermark=0&ui_help=0&ui_vr=0&ui_settings=0&ui_inspector=0&ui_hint=2&ui_color=01a982&ui_theme=dark&autostart=1&camera=0&

Secondary full-height riser cage

https://sketchfab.com/models/3305435c92a7448db3134b88e0437fbd/embed?ui_infos=0&ui_watermark=0&ui_help=0&ui_vr=0&ui_settings=0&ui_inspector=0&ui_hint=2&ui_color=01a982&ui_theme=dark&autostart=1&camera=0&



WARNING

To reduce the risk of personal injury from hot surfaces, allow the drives and the internal system components to cool before touching them.



CAUTION

A discharge of static electricity from a finger or other conductor might damage system boards or other static-sensitive devices. To prevent damage, observe antistatic precautions.

Procedure

1. Power down the server.
2. Remove all power:
 - a. Disconnect each power cord from the power source.
 - b. Disconnect each power cord from the server.
3. Do one of the following:
 - a. Extend the server from the rack.
 - b. Remove the server from the rack.
4. Place the server on a flat, level work surface.
5. Remove the access panel.
6. Remove the riser cage.

To remove the primary riser cage:

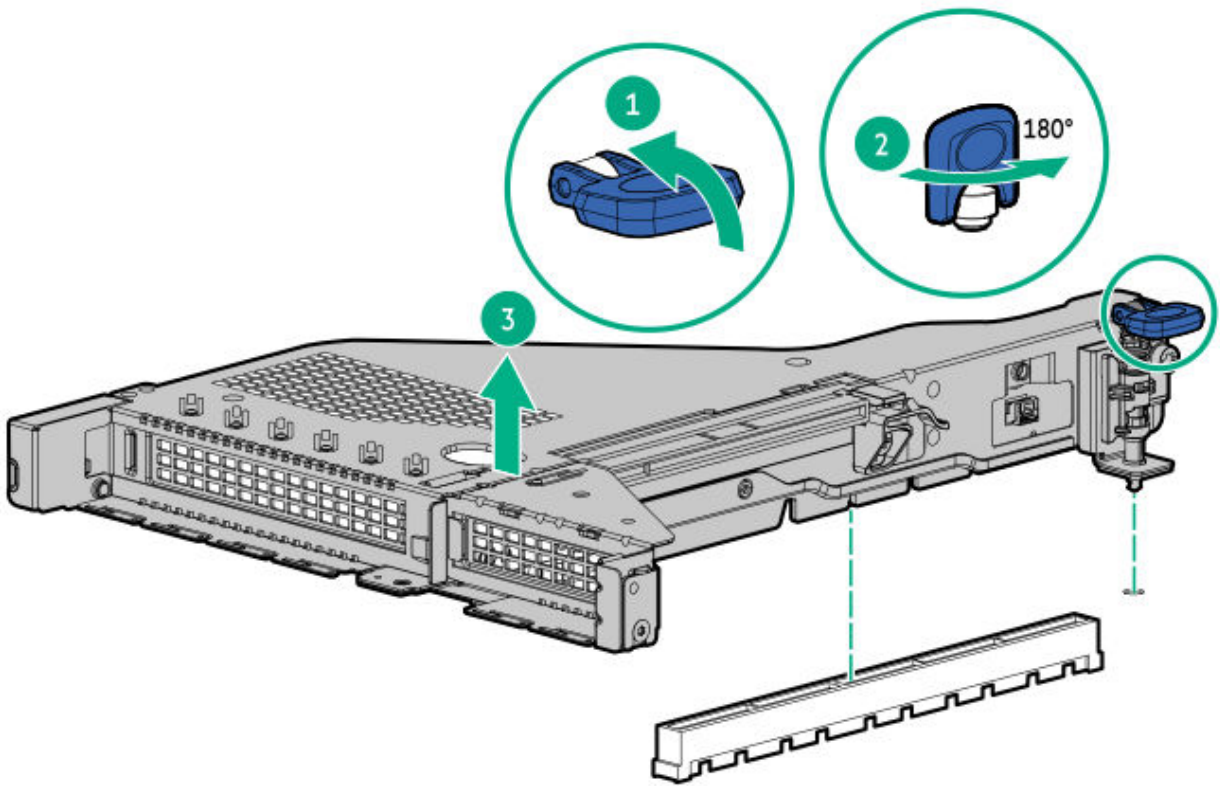

To remove the secondary low-profile riser cage:

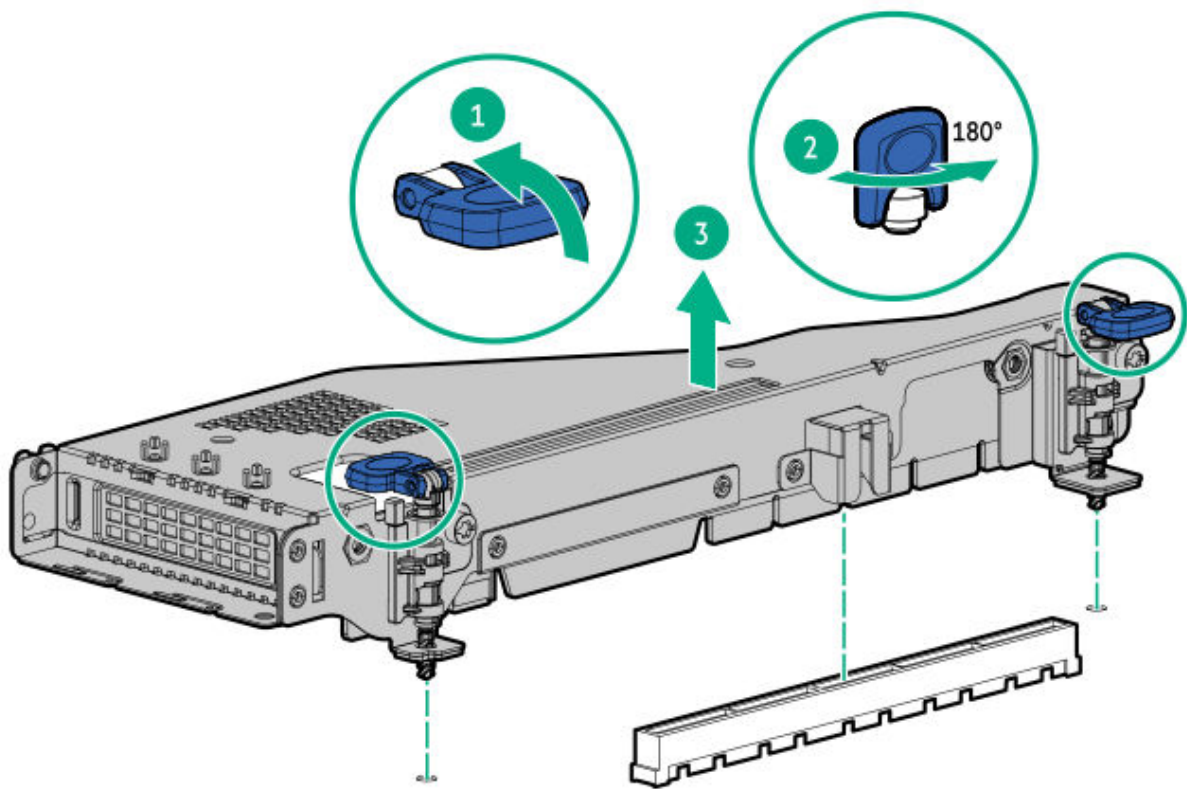

To remove the secondary full-height riser cage:

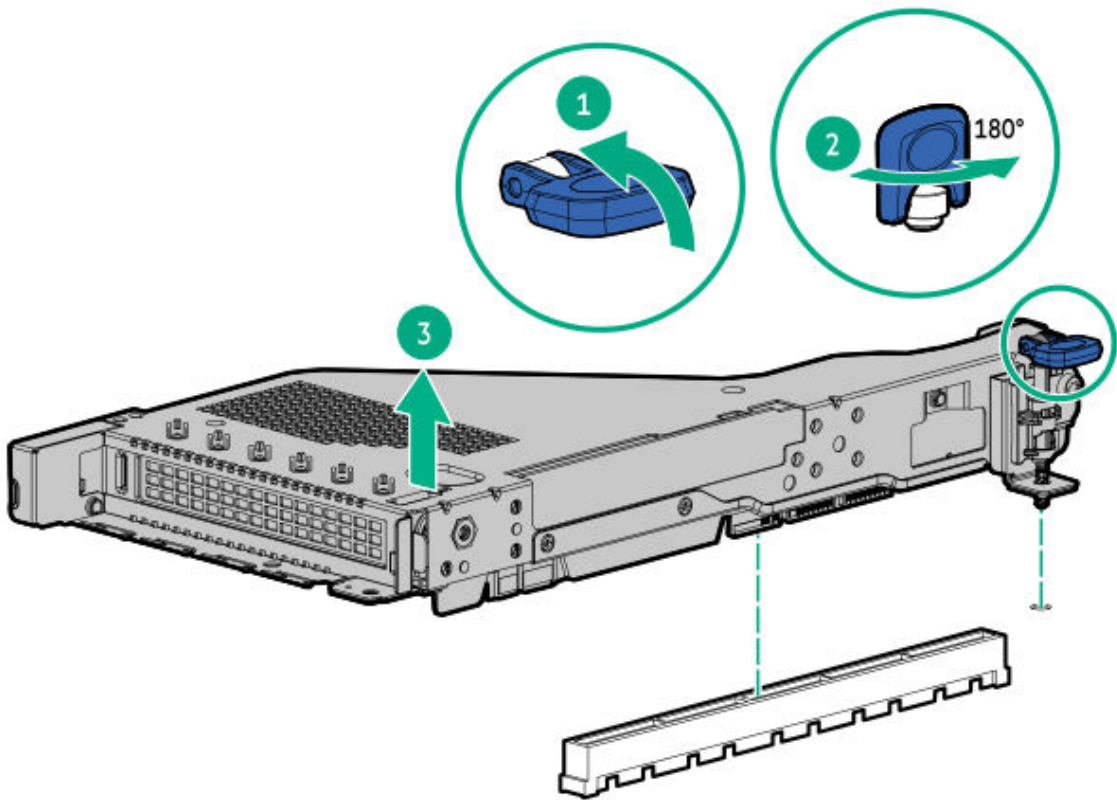

Results

The removal procedure is complete. To replace the component, reverse this procedure.

Removing and replacing an expansion card

Prerequisites

Before you perform this procedure, make sure that you have a T-10 Torx screwdriver available.

About this task



WARNING

To reduce the risk of personal injury, electric shock, or damage to the equipment, remove power from the server by removing the power cord. The front panel Power On/Standby button does not shut off system power. Portions of the power supply and some internal circuitry remain active until AC power is removed.



CAUTION

To prevent improper cooling and thermal damage, do not operate the server unless all PCIe slots have either a riser slot blank or an expansion card installed.



CAUTION

Before replacing a DIMM, backplane, expansion card, riser board, or other similar PCA components due to a perceived hardware error, make sure first that the component is firmly seated in the slot.

When installing the replacement component:

- Observe antistatic precautions.
- Handle the PCA only along the edges.
- Do not touch the components and connectors on the PCA.
- Do not bend or flex the PCA.

Procedure

1. Power down the server.
2. Remove all power:
 - a. Disconnect each power cord from the power source.
 - b. Disconnect each power cord from the server.
3. Do one of the following:
 - Extend the server from the rack.
 - Remove the server from the rack.
4. Place the server on a flat, level work surface.
5. Remove the access panel.
6. Remove the riser cage:

- Remove the primary riser cage.
- Remove the secondary riser cage.

7. Remove the expansion card from the riser cage.

- Primary slot 1

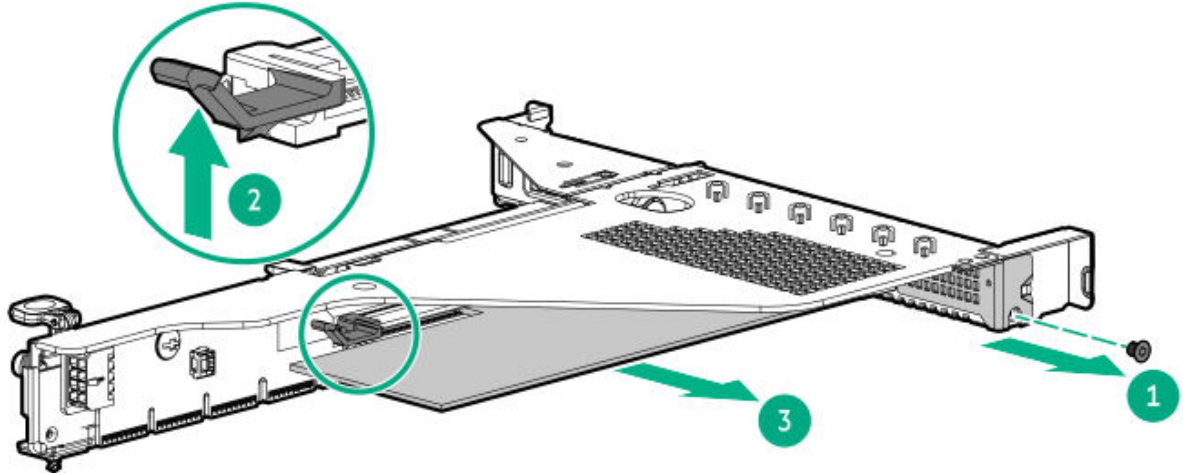

- Primary slot 2

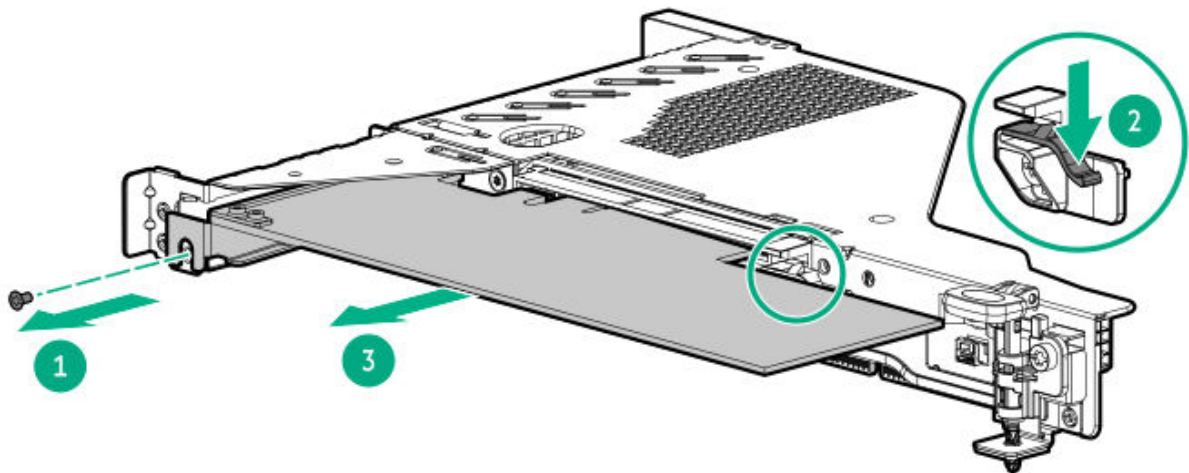

Results

The removal procedure is complete. To replace the component, reverse this procedure.

HPE NS204i-u Boot Device V2 replacement

Subtopics

- [Removing and replacing a boot device drive](#)
- [Removing and replacing the boot device cage](#)

Removing and replacing a boot device drive

Prerequisites

- Identify the failed drive, do one of the following:
 - [Locate the boot device drive with a flashing amber or blue Online/Activity LED.](#)
 - iLO web interface: **Storage** page
 - UEFI System Utilities: **System Utilities** > **Embedded Applications** > **Integrated Management Log** > **View IML**
- Before you perform this procedure, make sure that you have a Phillips No. 1 screwdriver available.

About this task

<https://sketchfab.com/models/bbb61184a86a4ca792b988e9caae5278/embed?>



CAUTION

To prevent improper cooling and thermal damage, do not operate the server unless all bays are populated with either a component or a blank.



CAUTION

Before replacing a DIMM, backplane, expansion card, riser board, or other similar PCA components due to a perceived hardware error, make sure first that the component is firmly seated in the slot.

When installing the replacement component:

- Observe antistatic precautions.
- Handle the PCA only along the edges.
- Do not touch the components and connectors on the PCA.
- Do not bend or flex the PCA.



IMPORTANT

For successful RAID 1 configuration, verify that the boot device SSDs have the same model number and firmware version:

- In the iLO web interface, see the **Storage** page.
- In UEFI System Utilities, see **System Configuration > HPE NS204i Boot Controller > Physical Device Information**.

Configurations with SSDs from different manufacturers are not supported.

Procedure

1. Back up all server data.
2. Remove the failed drive and replace it with a new drive:
 - a. Press and hold the carrier latch.
 - b. Pivot the latch to open.
 - c. Slide the carrier out from the boot device cage.

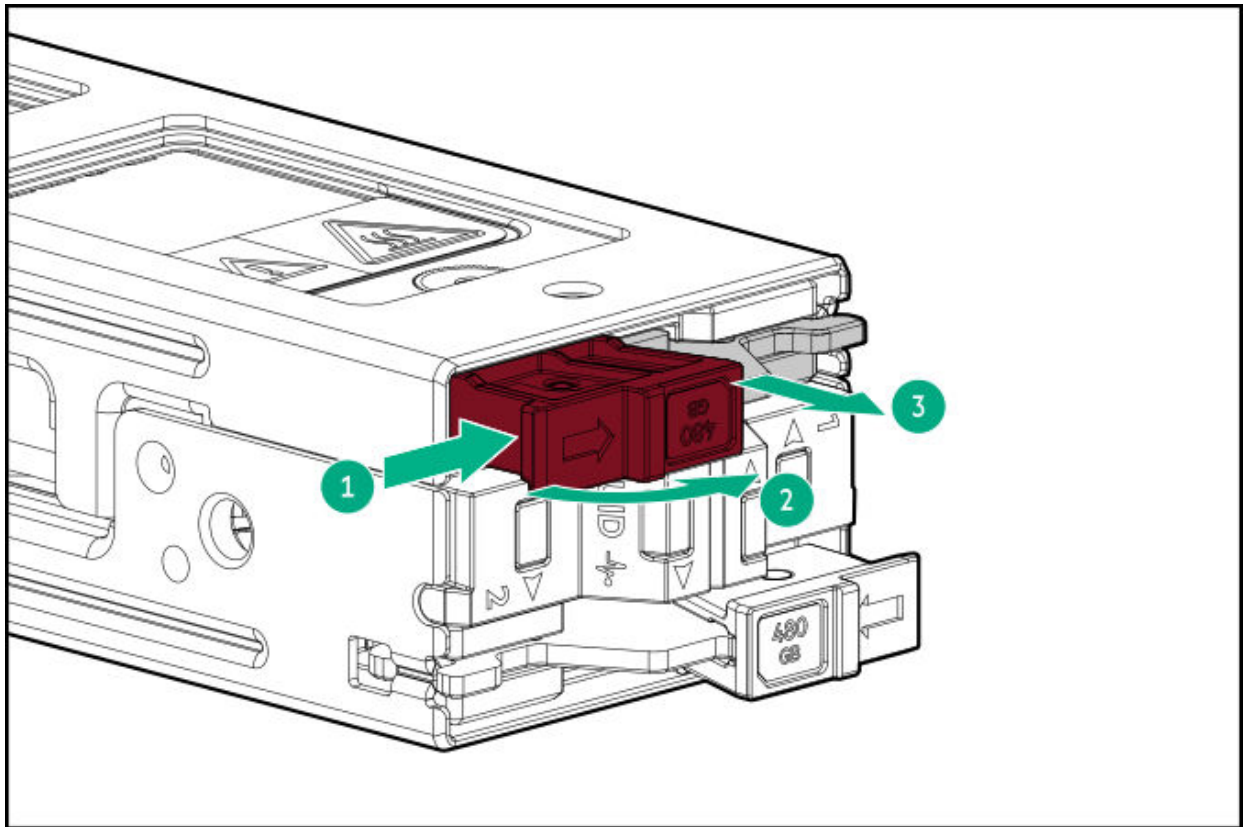

- d. Remove the SSD mounting screw.
- e. Tilt the SSD at a 45° angle, and then remove the failed SSD from the M.2 slot.



- f. Insert the new SSD into the M.2 slot at a 45° angle.
- g. Carefully press the SSD down to the horizontal position.
- h. Install the SSD mounting screw.

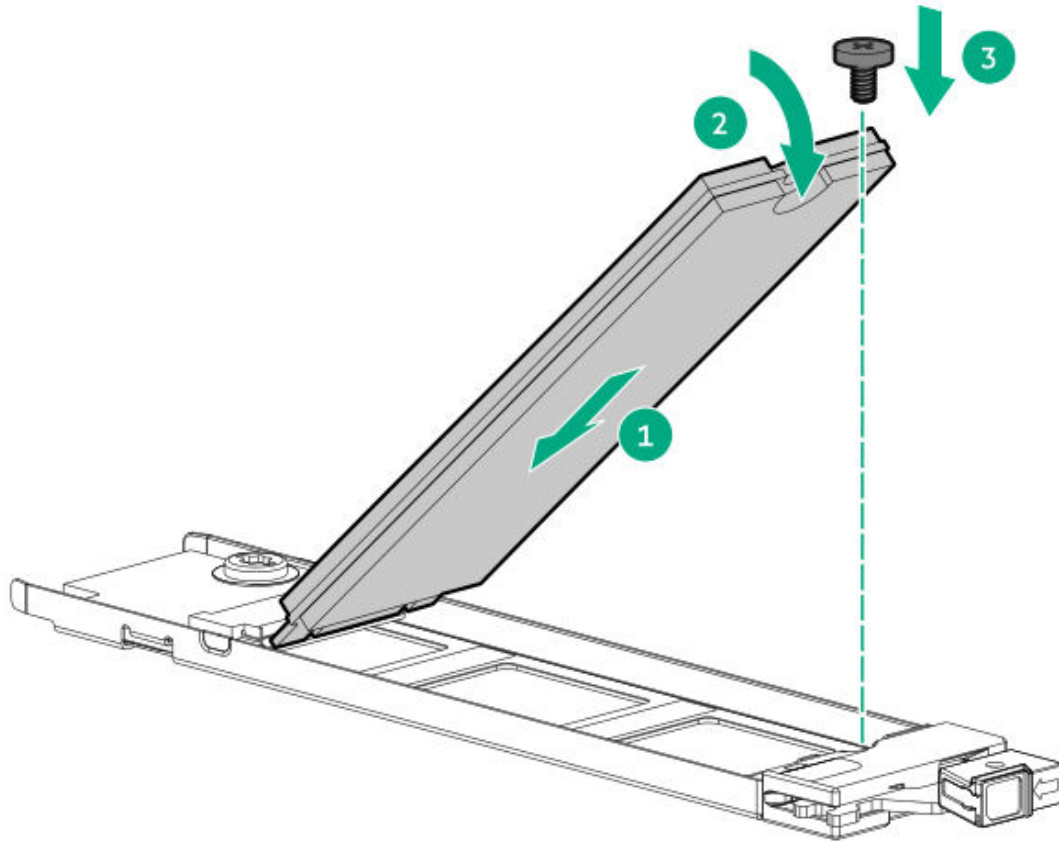

- i. If closed, pivot the carrier latch to open.
- j. Slide the carrier with the new SSD into the boot device cage.
- k. Pivot the latch to close.

Make sure that the carrier latch is locked on the boot device cage.

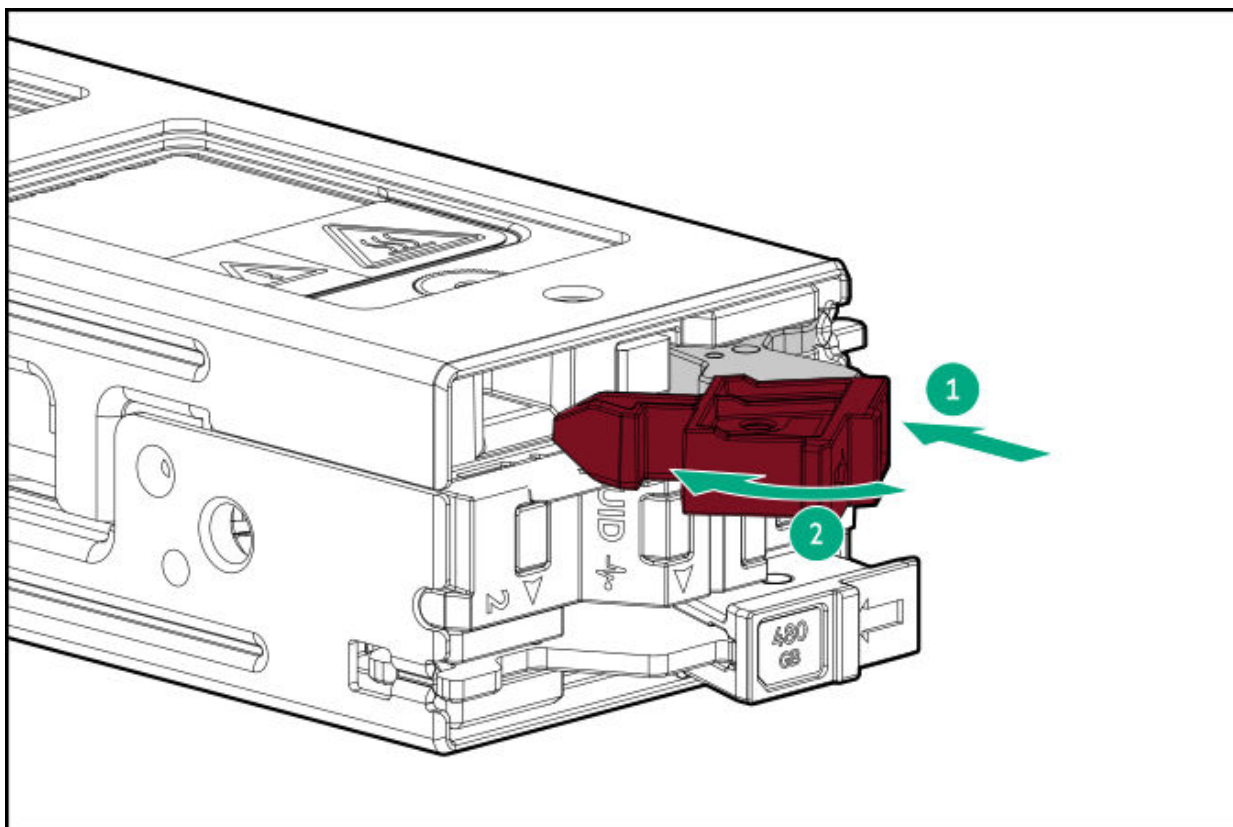

The boot device automatically rebuilds the RAID 1 volume.

3. If the newly installed SSD has a different model number as the SSD on the other drive carrier, replace the other SSD with one that is of the same model number as the new SSD.

Once both SSDs are installed, the boot device automatically rebuilds the RAID 1 volume.

4. To monitor the drive rebuild status, see any of the following:

- [Boot device Online/Activity LED](#)
- iLO web interface: **Storage** page
- UEFI System Utilities:
 - **System Utilities > System Configuration > Virtual Device Information > NS Volume > Virtual Device Detail Information**
 - **System Utilities > Embedded Applications > Integrated Management Log > View IML**

Results

The replacement procedure is complete.

Removing and replacing the boot device cage

Prerequisites

- Before you perform this procedure, make sure that you have the following items available:
 - T-10 Torx screwdriver
 - Phillips No. 1 screwdriver—

About this task

https://sketchfab.com/models/984a1645c21e40308830026b462525d5/embed?ui_infos=0&ui_watermark=0&ui_help=0&ui_vr=0&ui_settings=0&ui_inspector=0&ui_hint=2&ui_color=01a982&ui_theme=dark&autostart=1&camera=0&



CAUTION

To prevent improper cooling and thermal damage, do not operate the server unless all bays are populated with either a component or a blank.



CAUTION

A discharge of static electricity from a finger or other conductor might damage system boards or other static-sensitive devices. To prevent damage, observe [antistatic precautions](#).



IMPORTANT

For successful RAID 1 configuration, verify that the boot device SSDs have the same model number and firmware version:

- In the iLO web interface, see the **Storage** page.
- In UEFI System Utilities, see **System Configuration > HPE NS204i Boot Controller > Physical Device Information**.

Configurations with SSDs from different manufacturers are not supported.

Procedure

1. [Power down the server](#).
2. Remove all power:
 - a. Disconnect each power cord from the power source.
 - b. Disconnect each power cord from the server.

3. Do one of the following:
 - Extend the server from the rack.
 - Remove the server from the rack.
4. Place the server on a flat, level work surface.
5. Remove the access panel.
6. Disconnect any cables to the boot device.
7. Remove the boot device.
 - To remove the boot device from the riser cage:
 - a. Remove the drives.
Note where each drive was installed.
 - b. Remove the riser cage.
 - c. Remove the boot device.

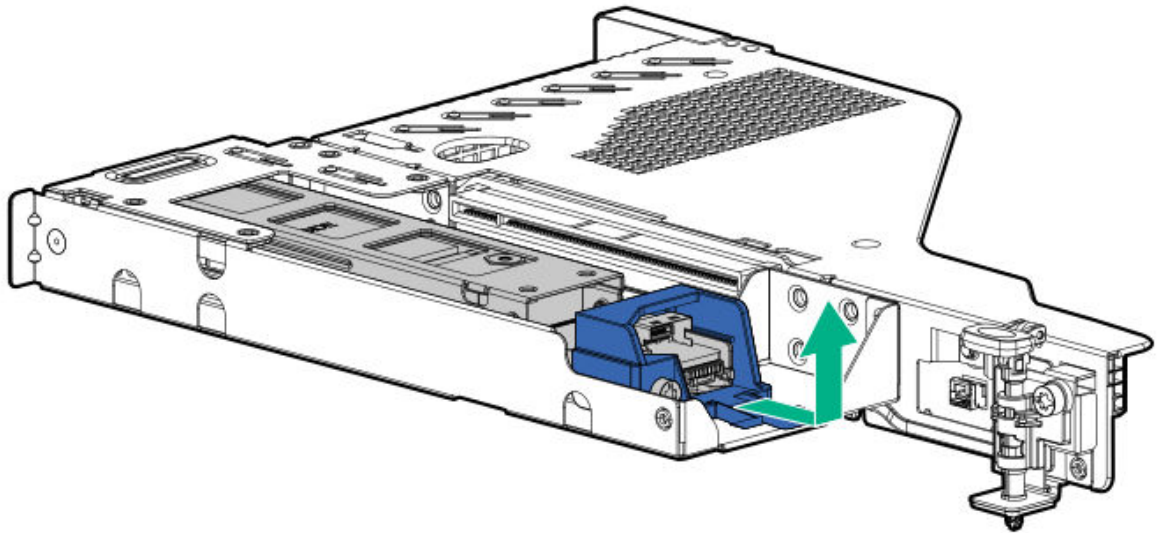

- To remove the internal boot device:
 - a. Remove the boot device.
 - 4 LFF server:

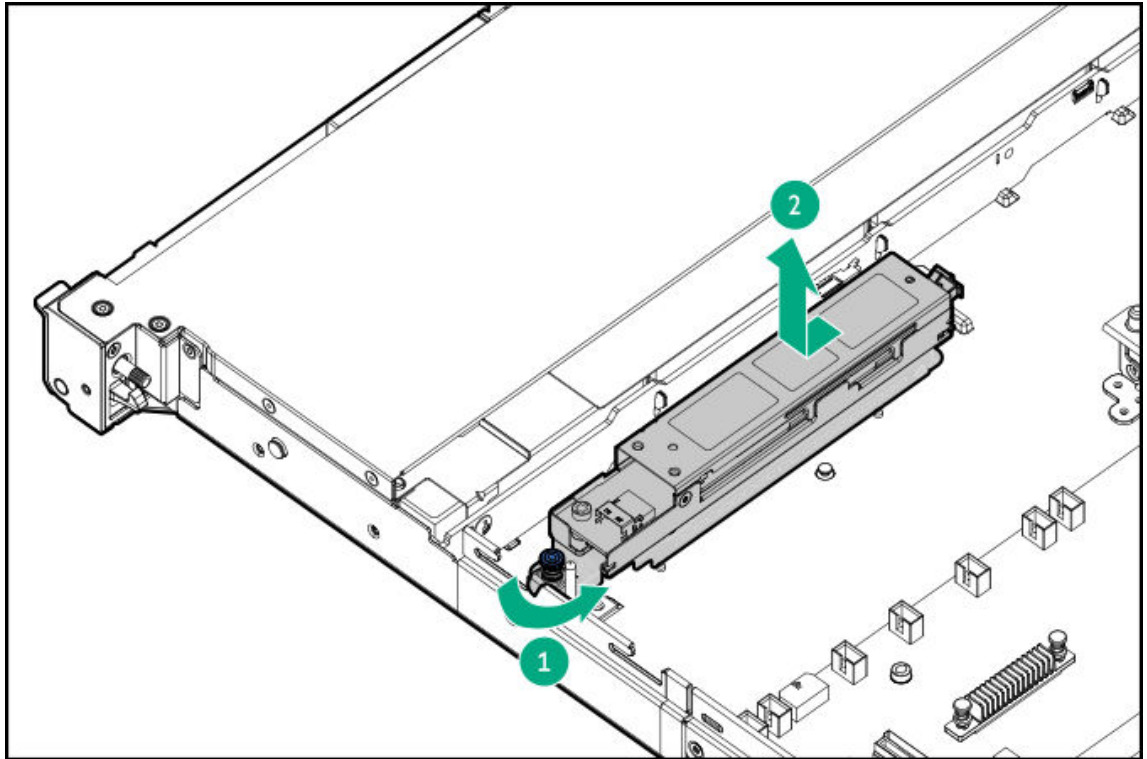

- 8 SFF server:

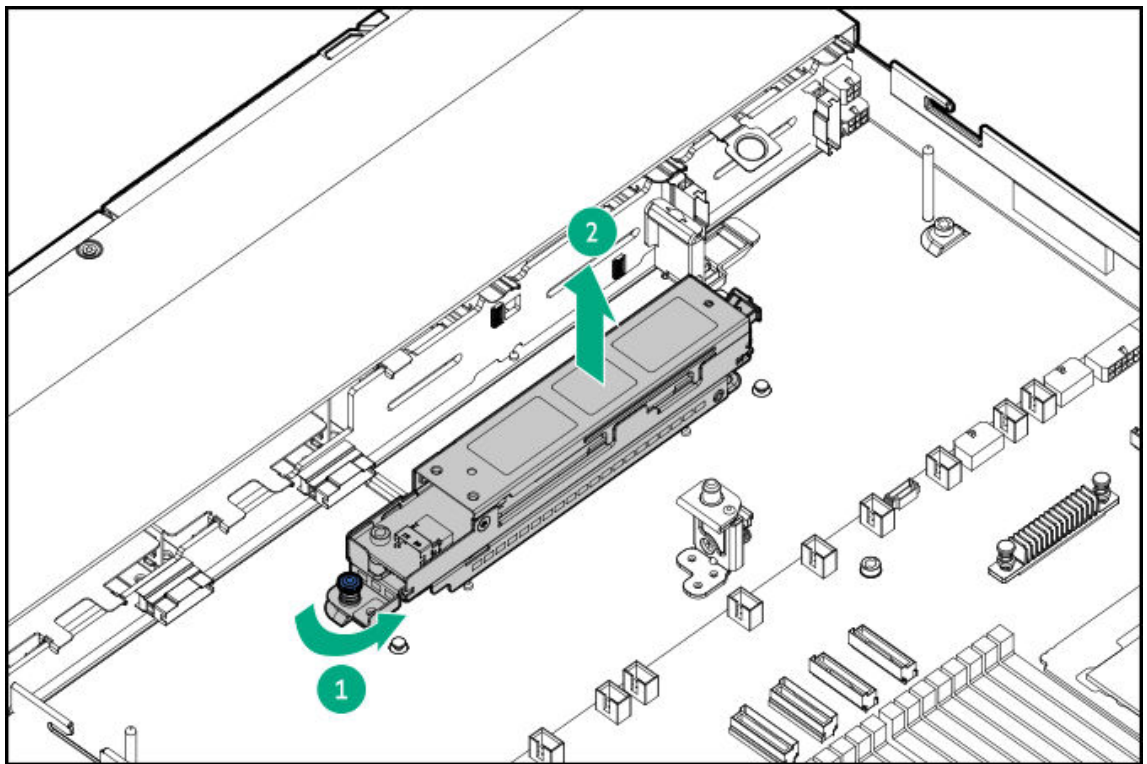

- 10 SFF / 20 E3.S server:

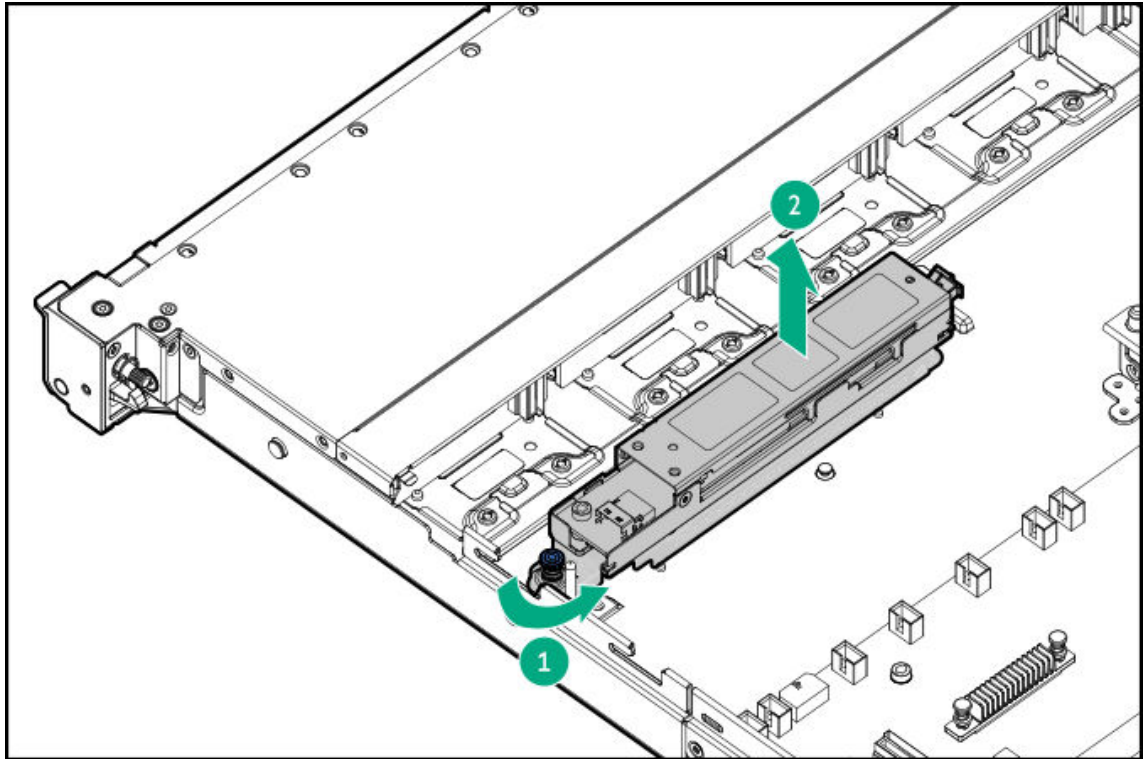

- Remove the support bracket

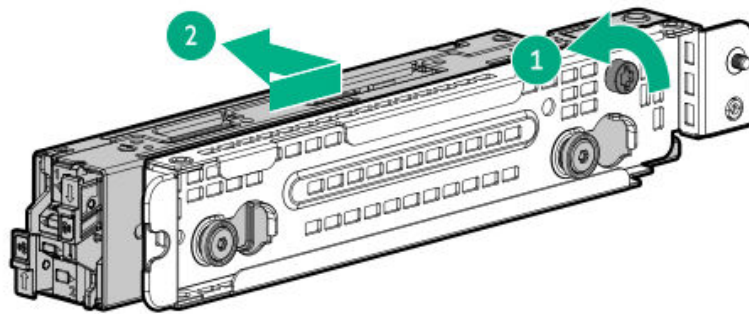

- To remove the front panel boot device:
 - a. Remove the boot device and E3.S cage from the server.

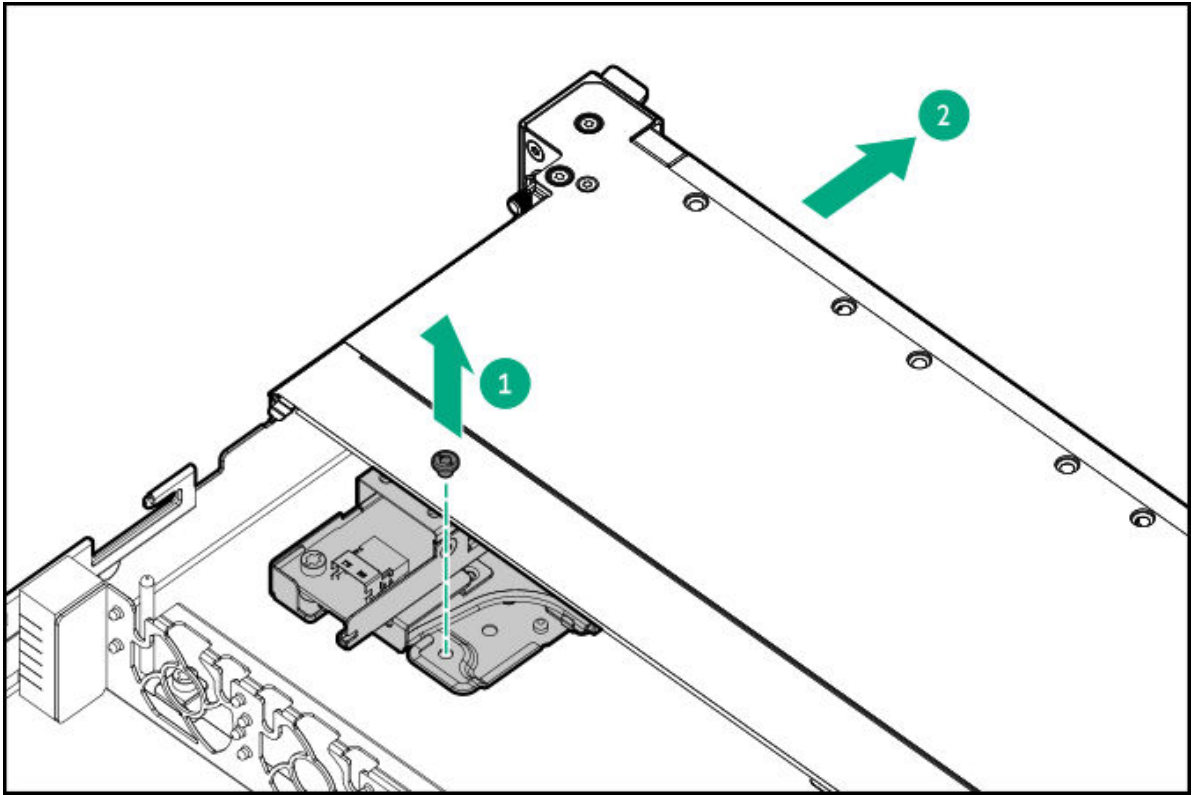

- b. Remove the boot device bracket from the E3.S cage.

Retain the screws. The screws will be used to install the boot device bracket back into the E3.S cage.

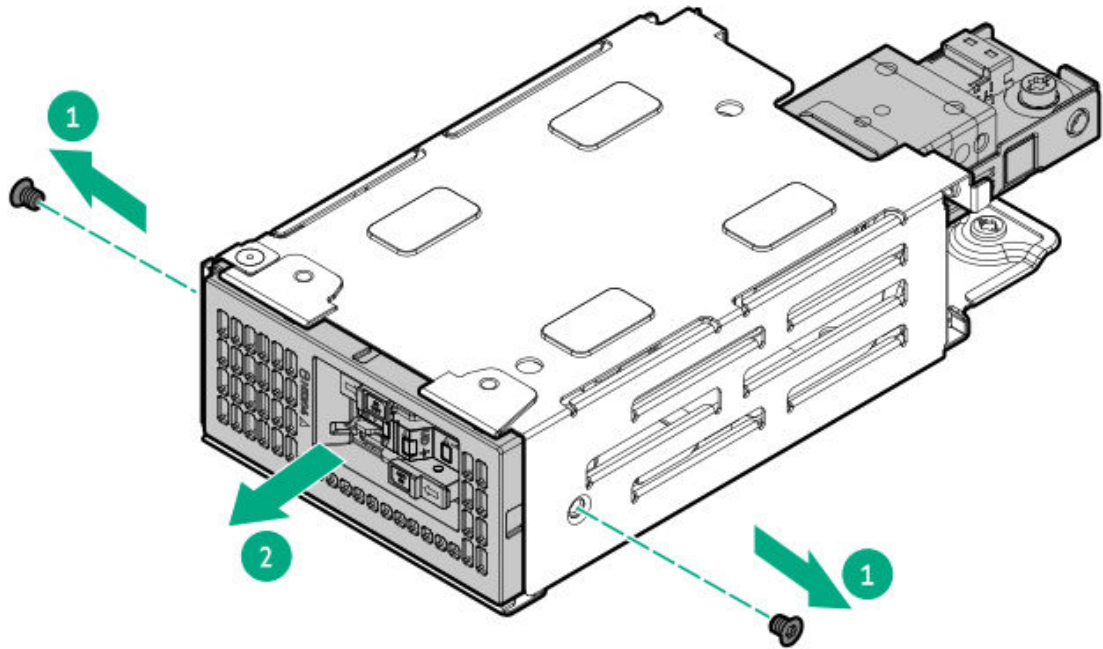

c. Remove the boot device from the bracket.

Retain the screw. The screw will be used to install the new boot device spare.

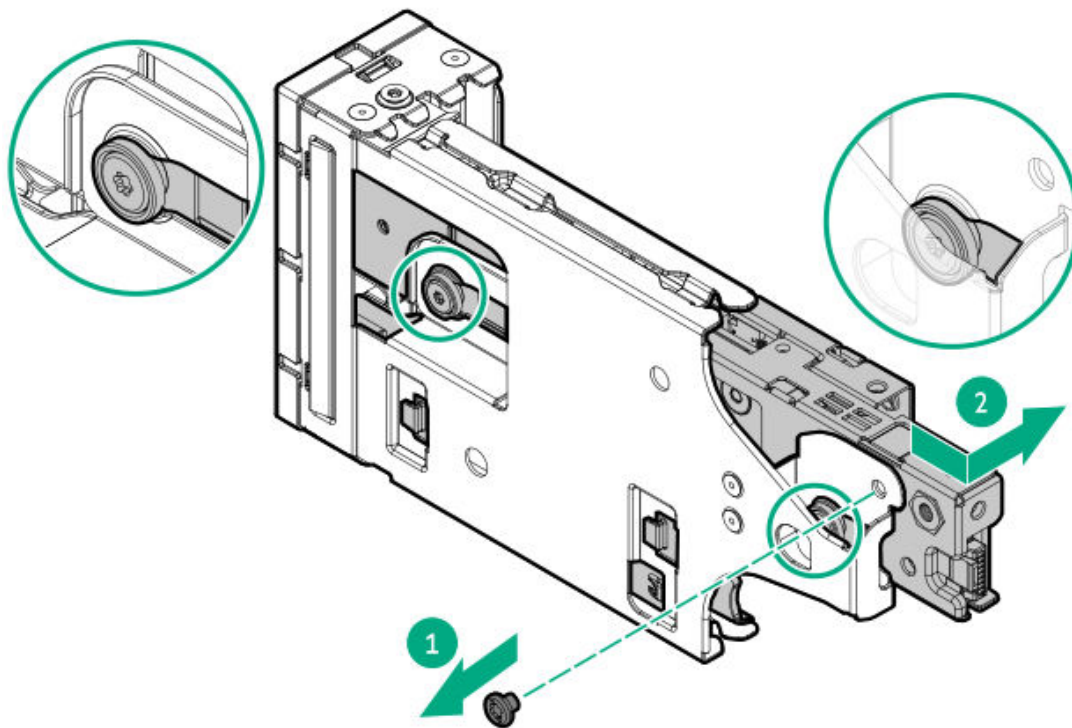

8. Remove the boot device carriers:
 - a. Press and hold the carrier latch.
 - b. Pivot the latch to open.
 - c. Slide the carrier out from the boot device cage.



Results

The removal procedure is complete. To replace the component, reverse this procedure.

Removing and replacing a primary riser board

Prerequisites

- Review [Riser board components](#).
- Before you perform this procedure, make sure that you have a T-15 Torx screwdriver available.

About this task

<https://sketchfab.com/models/c64cfd9ce1524bd9bffa40fde9a562d1/embed?>



CAUTION

Before replacing a DIMM, backplane, expansion card, riser board, or other similar PCA components due to a perceived hardware error, make sure first that the component is firmly seated in the slot.

When installing the replacement component:

- Observe antistatic precautions.
- Handle the PCA only along the edges.
- Do not touch the components and connectors on the PCA.
- Do not bend or flex the PCA.



CAUTION

To prevent damage to the server or expansion boards, power down the server and remove all AC power cords before removing or installing the PCI riser cage.

Procedure

1. Power down the server.
2. Remove all power:
 - a. Disconnect each power cord from the power source.
 - b. Disconnect each power cord from the server.
3. Do one of the following:
 - a. Extend the server from the rack.
 - b. Remove the server from the rack.
4. Place the server on a flat, level work surface.
5. Remove the access panel.
6. Remove the riser cage.

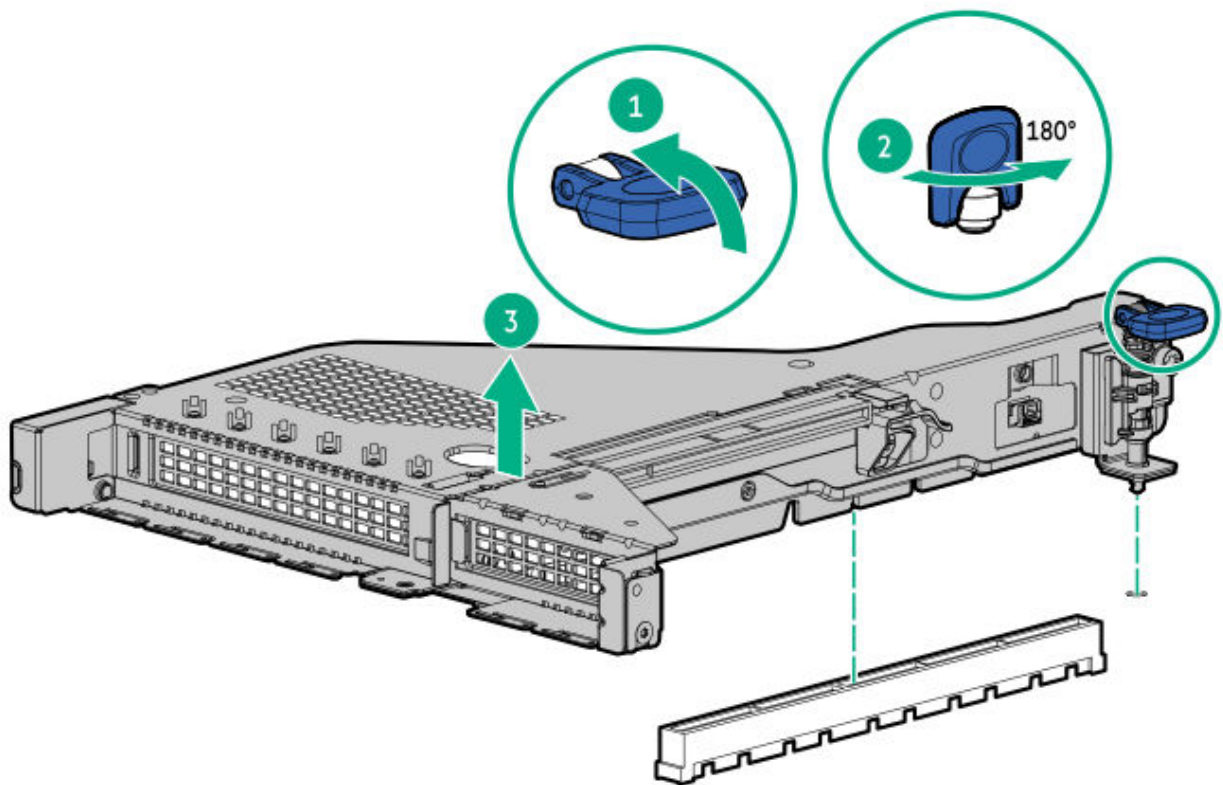

7. Remove all expansion cards.

8. Remove the riser.

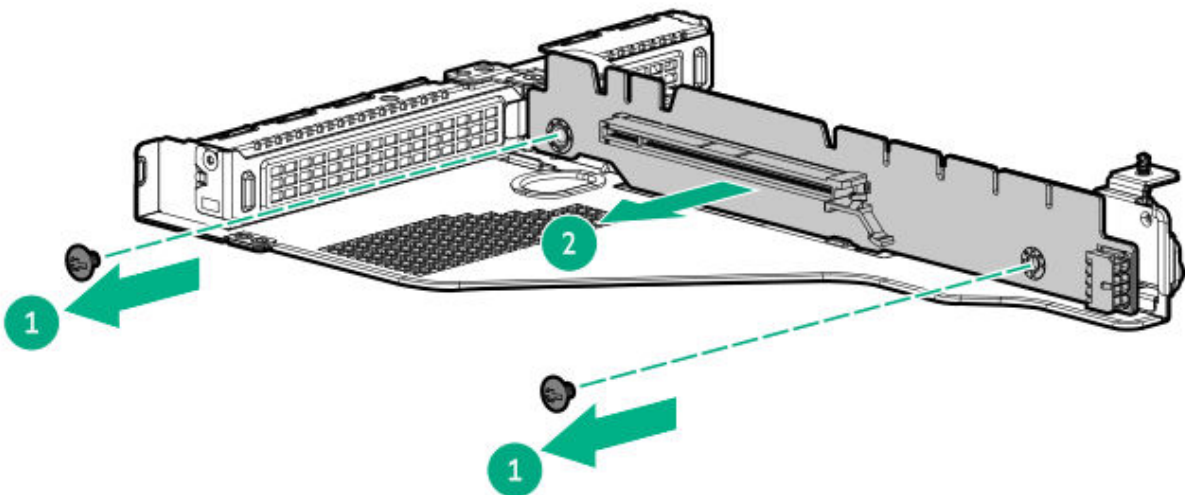

Results

The removal procedure is complete. To replace the component, reverse this procedure.

Removing and replacing the secondary low-profile riser

Prerequisites

- Review [Riser board components](#).
- Before you perform this procedure, make sure that you have a T-15 Torx screwdriver available.

About this task

https://sketchfab.com/models/ddb2528c65ff4cb686a40ed4aa4287a8/embed?ui_infos=0&ui_watermark=0&ui_help=0&ui_vr=0&ui_settings=0&ui_inspector=0&ui_hint=2&ui_color=01a982&ui_theme=dark&autostart=1&camera=0&



CAUTION

Before replacing a DIMM, backplane, expansion card, riser board, or other similar PCA components due to a perceived hardware error, make sure first that the component is firmly seated in the slot.

When installing the replacement component:

- Observe [antistatic precautions](#).
- Handle the PCA only along the edges.
- Do not touch the components and connectors on the PCA.
- Do not bend or flex the PCA.



CAUTION

To prevent damage to the server or expansion boards, power down the server and remove all AC power cords before removing or installing the PCI riser cage.

Procedure

1. [Power down the server](#).
2. Remove all power:

- a. Disconnect each power cord from the power source.
- b. Disconnect each power cord from the server.
3. Do one of the following:
 - a. Extend the server from the rack.
 - b. Remove the server from the rack.
4. Place the server on a flat, level work surface.
5. Remove the access panel.
6. Remove the riser cage.

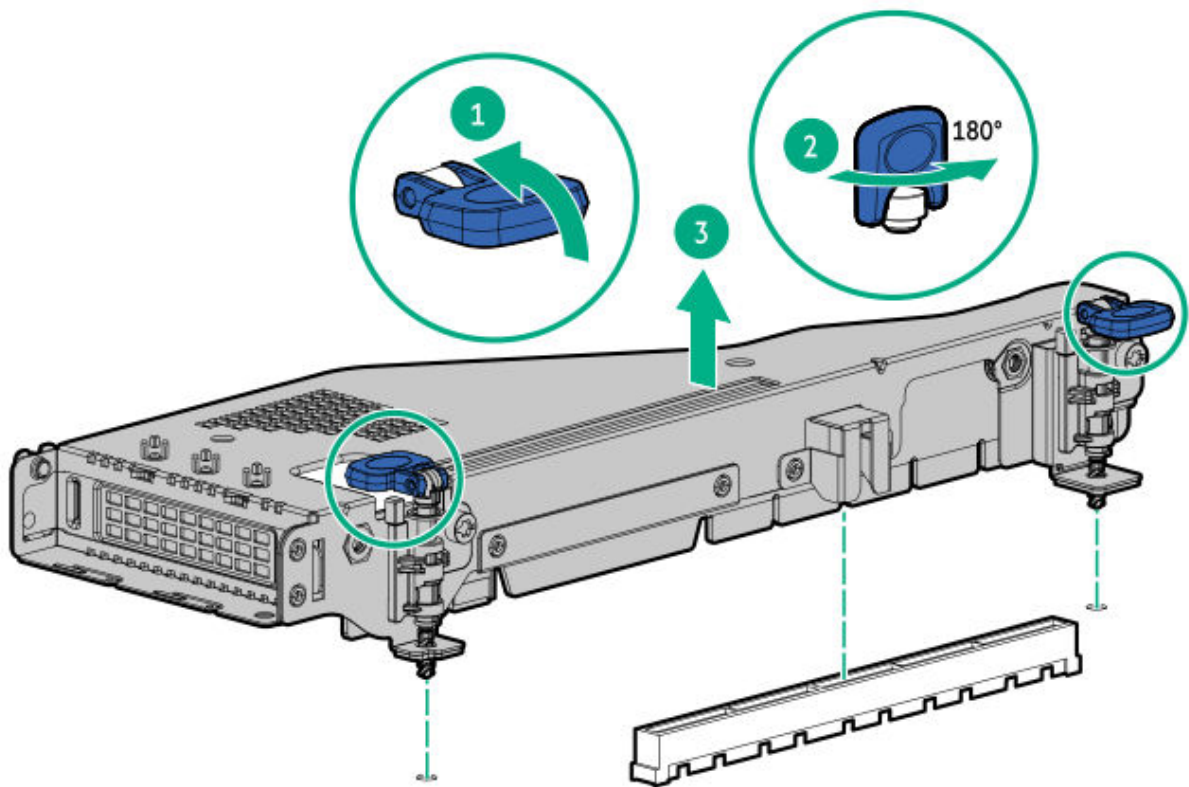

7. Remove all expansion cards.
8. Remove the riser.



Results

The removal procedure is complete. To replace the component, reverse this procedure.

Removing and replacing the serial port

Prerequisites

Be sure you have a 5 mm nut driver.

About this task

https://sketchfab.com/models/19545f2aca5b47ce8fb570196dc18c5d/embed?ui_infos=0&ui_watermark=0&ui_help=0&ui_vr=0&ui_settings=0&ui_inspector=0&ui_hint=2&ui_color=01a982&ui_theme=dark&autostart=1&camera=0&



CAUTION

To prevent improper cooling and thermal damage, do not operate the server unless the serial port slot has either a serial port or a serial port blank installed.



CAUTION

A discharge of static electricity from a finger or other conductor might damage system boards or other static-sensitive devices. To prevent damage, observe antistatic precautions.

Procedure

1. [Power down the server.](#)
2. Remove all power:
 - a. Disconnect each power cord from the power source.
 - b. Disconnect each power cord from the server.
3. Disconnect any external cables that are connected to the expansion board.
4. Do one of the following:
 - [Extend the server from the rack.](#)
 - [Remove the server from the rack.](#)
5. Place the server on a flat, level work surface.

6. Remove the access panel.
7. Remove all riser cages.
8. Disconnect the serial port cable from the system board.
9. Using a 5mm nut driver, remove the serial port.



Results

The removal procedure is complete. To replace the component, reverse this procedure.

Removing and replacing the chassis intrusion detection switch

About this task



CAUTION

A discharge of static electricity from a finger or other conductor might damage system boards or other static-sensitive devices. To prevent damage, observe antistatic precautions.

Procedure

1. Power down the server.
2. Remove all power:
 - a. Disconnect each power cord from the power source.
 - b. Disconnect each power cord from the server.
3. Disconnect all peripheral cables from the server.
4. Do one of the following:
 - a. Extend the server from the rack.
 - b. Remove the server from the rack.
5. Place the server on a flat, level work surface.

6. Remove the access panel.
7. Remove the chassis intrusion detection switch.

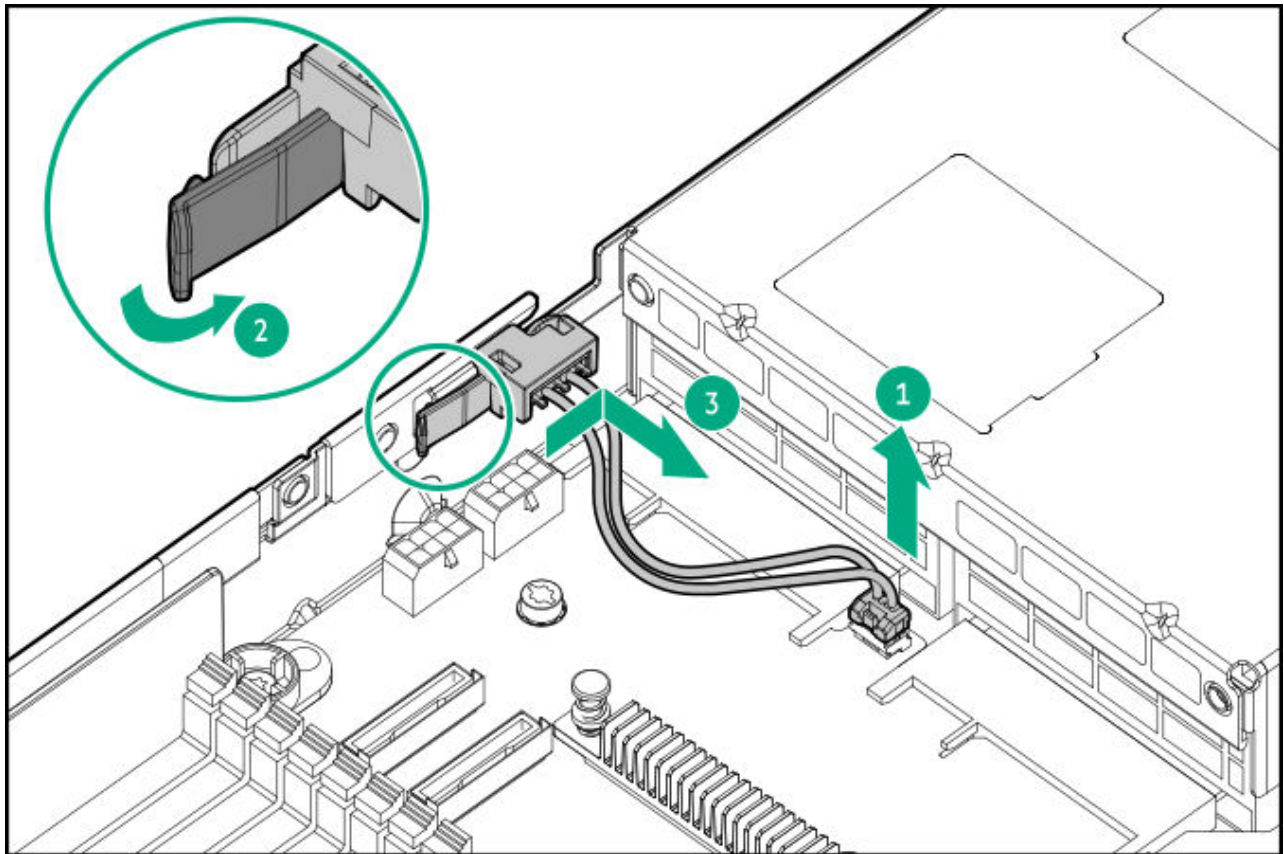

Results

The removal procedure is complete. To replace the component, reverse this procedure.

Removing and replacing a rear OCP 3.0 network adapter

About this task

<https://sketchfab.com/models/ac02ab5a52f140faa5c7e7a4444f9683/embed?>



WARNING

To reduce the risk of personal injury, electric shock, or damage to the equipment, remove power from the server by removing the power cord. The front panel Power On/Standby button does not shut off system power. Portions of the power supply and some internal circuitry remain active until AC power is removed.



CAUTION

To prevent improper cooling and thermal damage, do not operate the server unless all OCP slots have either an OCP option or a slot blank installed.



CAUTION

Before replacing a DIMM, backplane, expansion card, riser board, or other similar PCA components due to a perceived hardware error, make sure first that the component is firmly seated in the slot.

When installing the replacement component:

- Observe antistatic precautions.
- Handle the PCA only along the edges.
- Do not touch the components and connectors on the PCA.
- Do not bend or flex the PCA.

Procedure

1. Power down the server.
2. Remove all power:
 - a. Disconnect each power cord from the power source.
 - b. Disconnect each power cord from the server.
3. Disconnect any external cables that are connected to the expansion board.
4. Do one of the following:
 - Extend the server from the rack.
 - Remove the server from the rack.
5. Place the server on a flat, level work surface.

6. Remove the access panel.
7. If installed, remove the riser cage.
8. Remove the OCP 3.0 adapter.

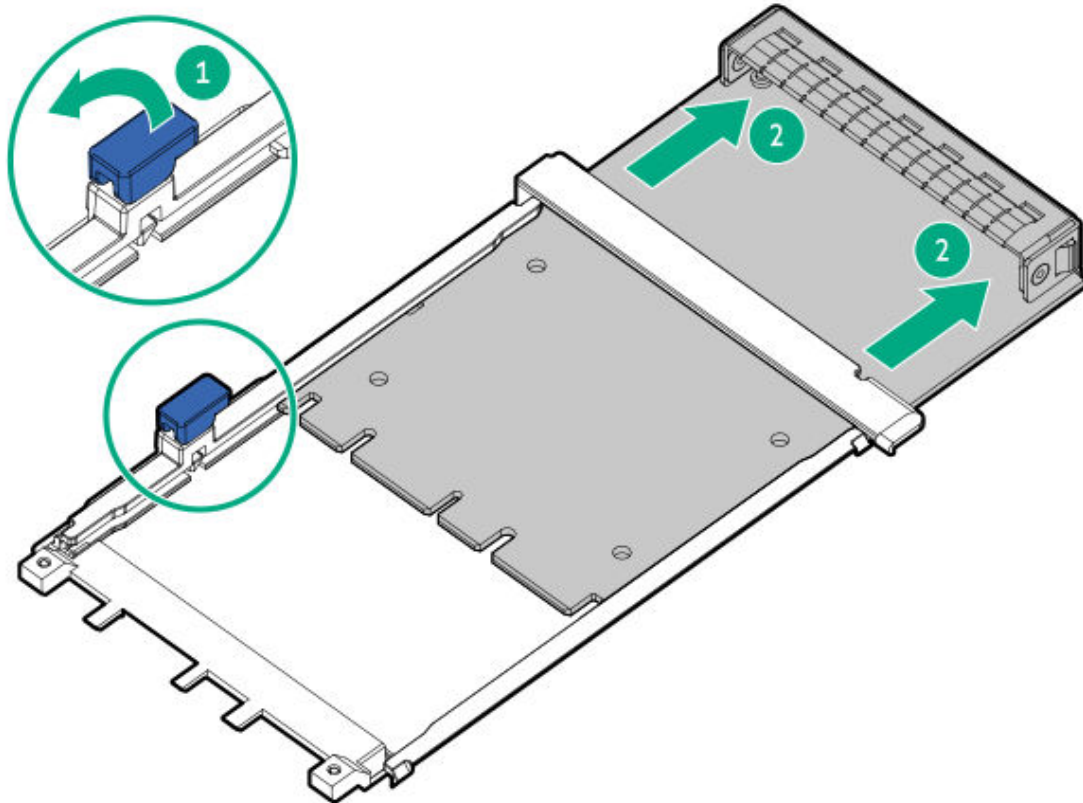

Results

The removal procedure is complete. To replace the component, reverse this procedure.

Removing and replacing a type-o storage controller

About this task

<https://sketchfab.com/models/ac02ab5a52f140faa5c7e7a4444f9683/embed?>



WARNING

To reduce the risk of personal injury, electric shock, or damage to the equipment, remove power from the server by removing the power cord. The front panel Power On/Standby button does not shut off system power. Portions of the power supply and some internal circuitry remain active until AC power is removed.



CAUTION

To prevent improper cooling and thermal damage, do not operate the server unless all OCP slots have either an OCP option or a slot blank installed.



CAUTION

Before replacing a DIMM, backplane, expansion card, riser board, or other similar PCA components due to a perceived hardware error, make sure first that the component is firmly seated in the slot.

When installing the replacement component:

- Observe antistatic precautions.
- Handle the PCA only along the edges.
- Do not touch the components and connectors on the PCA.
- Do not bend or flex the PCA.

Procedure

1. Power down the server.
2. Remove all power:
 - a. Disconnect each power cord from the power source.
 - b. Disconnect each power cord from the server.
3. Disconnect any external cables that are connected to the expansion board.
4. Do one of the following:
 - Extend the server from the rack.
 - Remove the server from the rack.
5. Place the server on a flat, level work surface.

6. Remove the access panel.
7. If installed, remove the riser cage.
8. Remove the type-o storage controller.

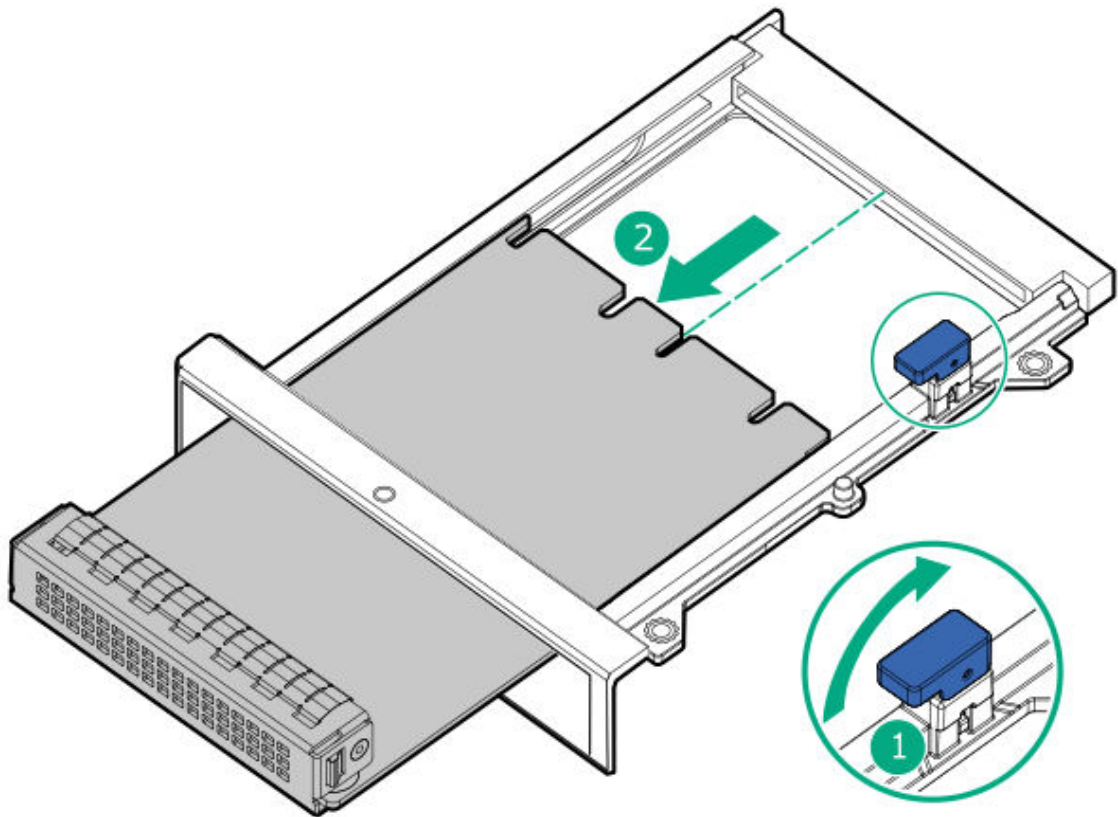

Results

The removal procedure is complete. To replace the component, reverse this procedure.

Removing and replacing a type-p storage controller

Prerequisites

Before you perform this procedure, make sure that you have a T-15 Torx screwdriver available.

About this task



WARNING

To reduce the risk of personal injury, electric shock, or damage to the equipment, remove power from the server by removing the power cord. The front panel Power On/Standby button does not shut off system power. Portions of the power supply and some internal circuitry remain active until AC power is removed.



CAUTION

Before replacing a DIMM, backplane, expansion card, riser board, or other similar PCA components due to a perceived hardware error, make sure first that the component is firmly seated in the slot.

When installing the replacement component:

- Observe antistatic precautions.
- Handle the PCA only along the edges.
- Do not touch the components and connectors on the PCA.
- Do not bend or flex the PCA.

Procedure

1. Power down the server.
2. Remove all power:
 - a. Disconnect each power cord from the power source.
 - b. Disconnect each power cord from the server.
3. Do one of the following:
 - Extend the server from the rack.
 - Remove the server from the rack.
4. Place the server on a flat, level work surface.
5. Remove the access panel.
6. Remove the riser cage:
 - Remove the primary riser cage.
 - Remove the secondary riser cage.

7. Disconnect any cables from the storage controller.

Note the connection for each cable.

8. Remove the storage controller from the riser cage.

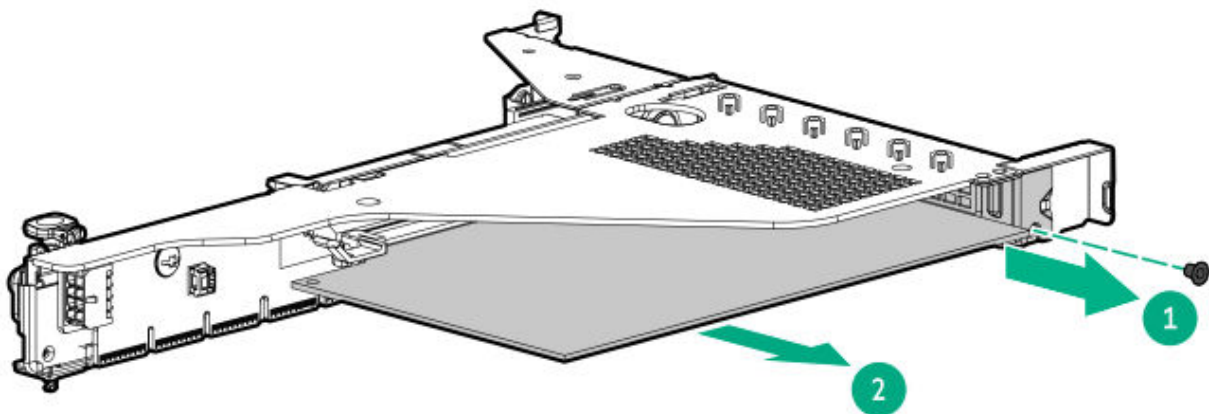

Results

The removal procedure is complete. To replace the component, reverse this procedure.

System battery information

The server contains an internal lithium manganese dioxide, a vanadium pentoxide, or an alkaline battery that provides power to the real-time clock.



WARNING

If this battery is not properly handled, a risk of fire or burning exists. To reduce the risk of personal injury:

- Do not attempt to recharge the battery.
- Do not expose the battery to temperatures higher than 60°C (140°F).
- Do not expose the battery to low air pressure as it might lead to explosion or leakage of flammable liquid or gas.
- Do not disassemble, crush, puncture, short external contacts, or dispose of the battery in fire or water.

Removing and replacing the system battery

Prerequisites

- Review [System battery information](#).
- Before you perform this procedure, make sure that you have a small flat-bladed, nonconductive tool available.

About this task

The system battery provides power to the real-time clock. If the server no longer automatically displays the correct date and time, you might need to replace the system battery.

<https://sketchfab.com/models/6f2a2a1a5c8540cb9a3adc740b055e0e/embed?>



IMPORTANT

After replacing the system battery and applying power, wait for 10 minutes before powering on the server. This lead time is required for the server to reset and reinitialize the iLO configuration settings stored in SRAM.



CAUTION

A discharge of static electricity from a finger or other conductor might damage system boards or other static-sensitive devices. To prevent damage, observe antistatic precautions.

Procedure

1. Power down the server.
2. Remove all power:
 - a. Disconnect each power cord from the power source.
 - b. Disconnect each power cord from the server.
3. Disconnect any external cables that are connected to the expansion board.
4. Do one of the following:
 - Extend the server from the rack.
 - Remove the server from the rack.
5. Place the server on a flat, level work surface.
6. Remove the access panel.
7. Locate the battery on the system board.
8. Remove the system battery:
 - a. Use a small flat-bladed, nonconductive tool to press the battery latch.
 - b. Remove the system battery from the socket.

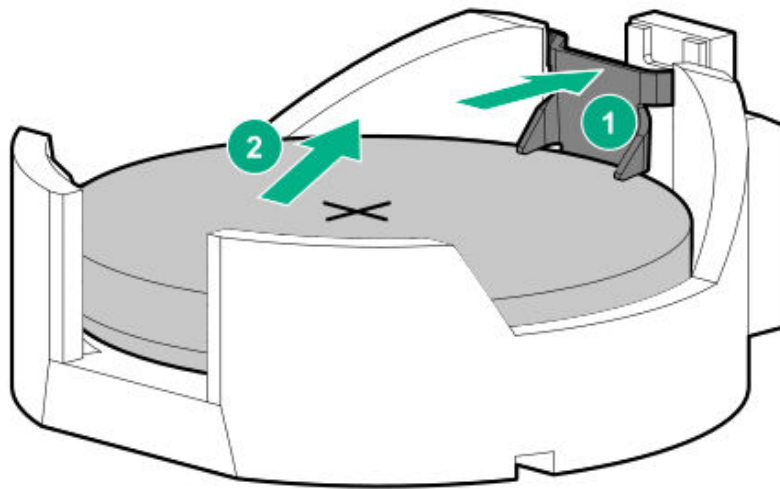

9. Install the system battery:

- a. With the side of the battery showing the "+" sign facing up, insert the battery into the socket.
- b. Press the system battery down until it clicks into place.

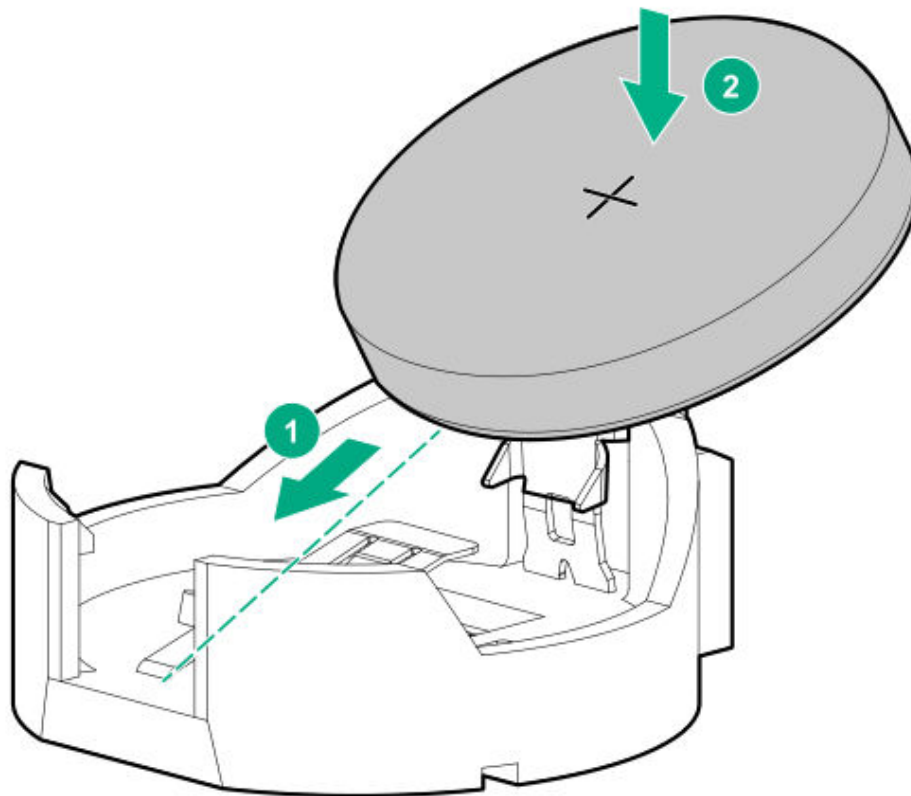

- .0. Wait for 10 minutes for the server to reset and reinitialize the iLO configuration settings stored in SRAM.



IMPORTANT

If iLO security is disabled, the configuration will not be restored. To restore the configuration manually, see <https://www.hpe.com/support/hpeilodocs-quicklinks>.

- .1. Install the access panel.
- .2. Install the server into the rack.
- .3. Connect all peripheral cables to the server.
- .4. Connect each power cord to the server.
- .5. Connect each power cord to the power source.
- .6. Power up the server.
- .7. Properly dispose of the old battery.

For more information about proper battery disposal, contact an authorized reseller or an authorized service provider.

Results

The replacement procedure is complete.

Heatsink replacement

Subtopics

- [Removing a standard or high performance heatsink](#)
- [Installing a standard or high performance heatsink](#)

Removing a standard or high performance heatsink

Prerequisites

- [Identify the heatsink and processor socket components.](#)
- [Review the processor cautions.](#)

- Before you perform this procedure, make sure that you have the following items available:
 - T-30 Torx screwdriver or a bit driver with T-30 Torx bit
 - Alcohol wipe
 - Processor socket dust cover—This is needed if you are not immediately installing the replacement processor-heatsink assembly.

About this task

Standard heatsink:

https://sketchfab.com/models/9fe740559dd94ff49c7da212d810cf68/embed?ui_infos=0&ui_watermark=0&ui_help=0&ui_vr=0&ui_settings=0&ui_inspector=0&ui_hint=2&ui_color=01a982&ui_theme=dark&autostart=1&camera=0&



WARNING

To reduce the risk of personal injury from hot surfaces, allow the drives and the internal system components to cool before touching them.



CAUTION

A discharge of static electricity from a finger or other conductor might damage system boards or other static-sensitive devices. To prevent damage, observe [antistatic precautions](#).

Procedure

1. [Power down the server](#).
2. Remove all power:
 - a. Disconnect each power cord from the power source.
 - b. Disconnect each power cord from the server.
3. Disconnect all peripheral cables from the server.
4. If the server is installed in an enclosure or a rack, remove the server and place it on a flat, level work surface.
5. [Remove the access panel](#).
6. Allow all internal system components to cool before continuing.
7. If installed, remove the air baffle.

An 8 SFF server is shown. The removal procedure is the same for all drive configurations.

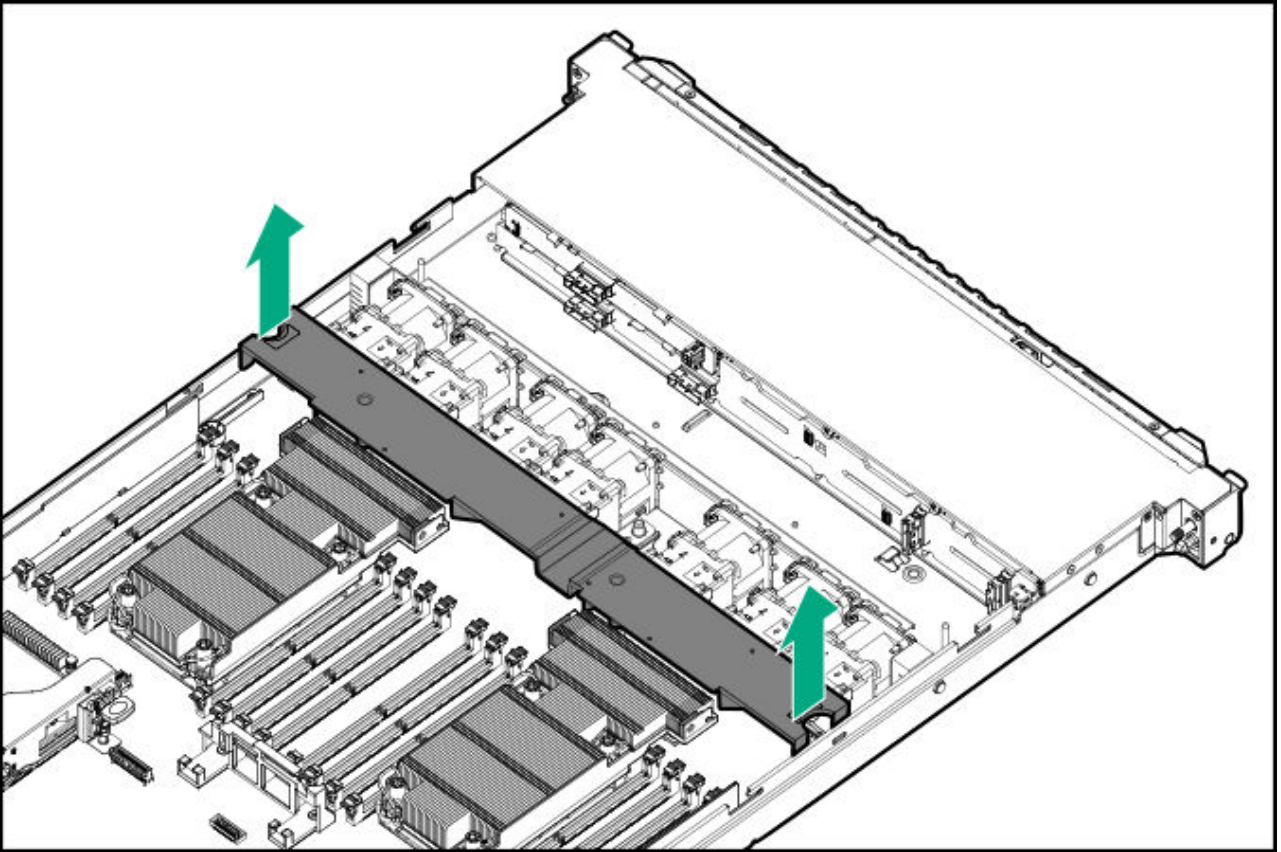

8.



CAUTION

Heatsink screws must be tightened and loosened in alternating sequence. Do not overtighten the screws as this might damage the system board or the processor socket.

Use a T-30 Torx screwdriver to loosen one pair of diagonally opposite heatsink screws (callouts 1 and 2), and then loosen the other pair of heatsink screws (callouts 3 and 4).

- Standard heatsink

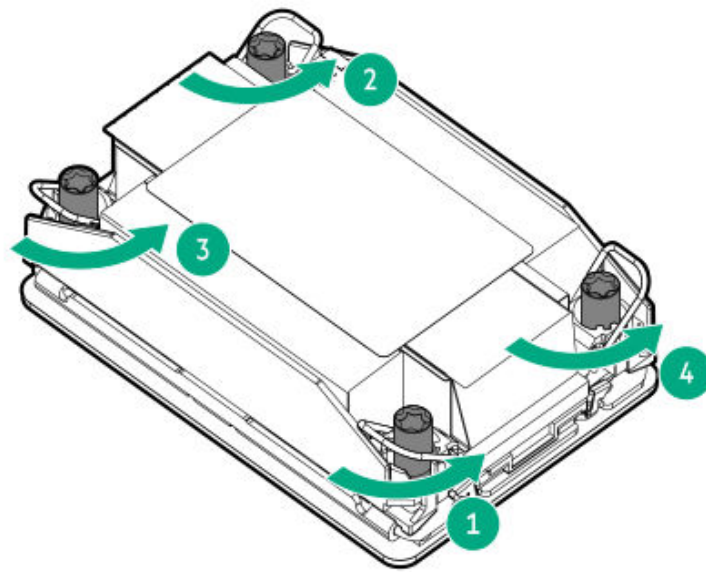

- High performance heatsink

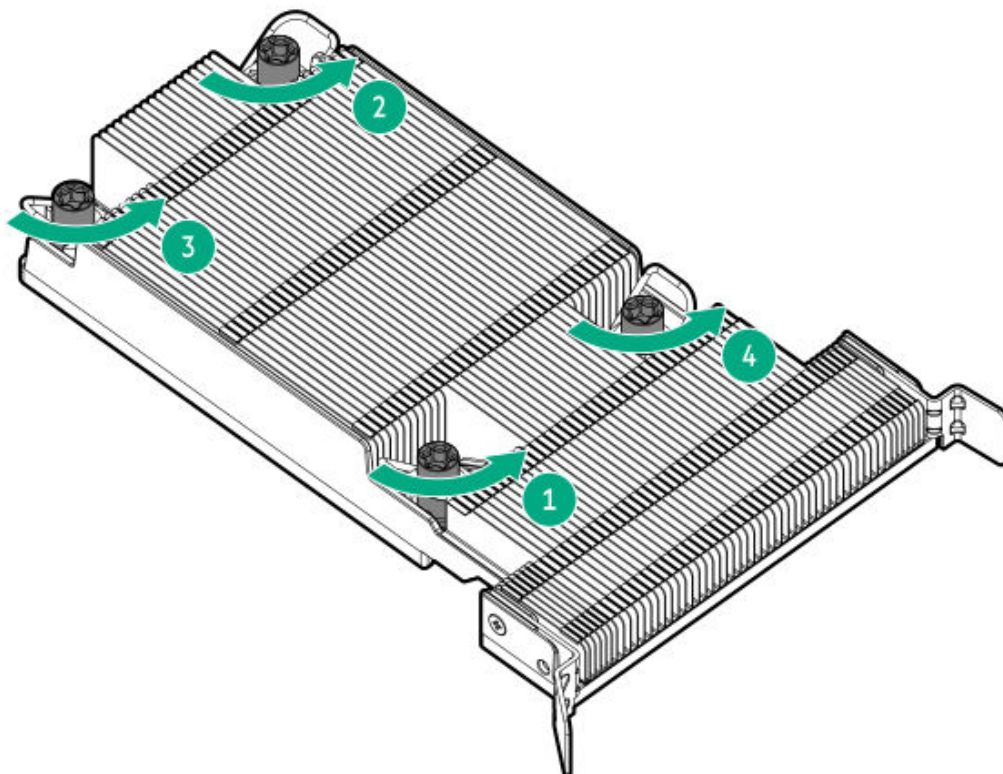

9. Set the anti-tilt wires to the unlocked position.

- Standard heatsink



- High performance heatsink

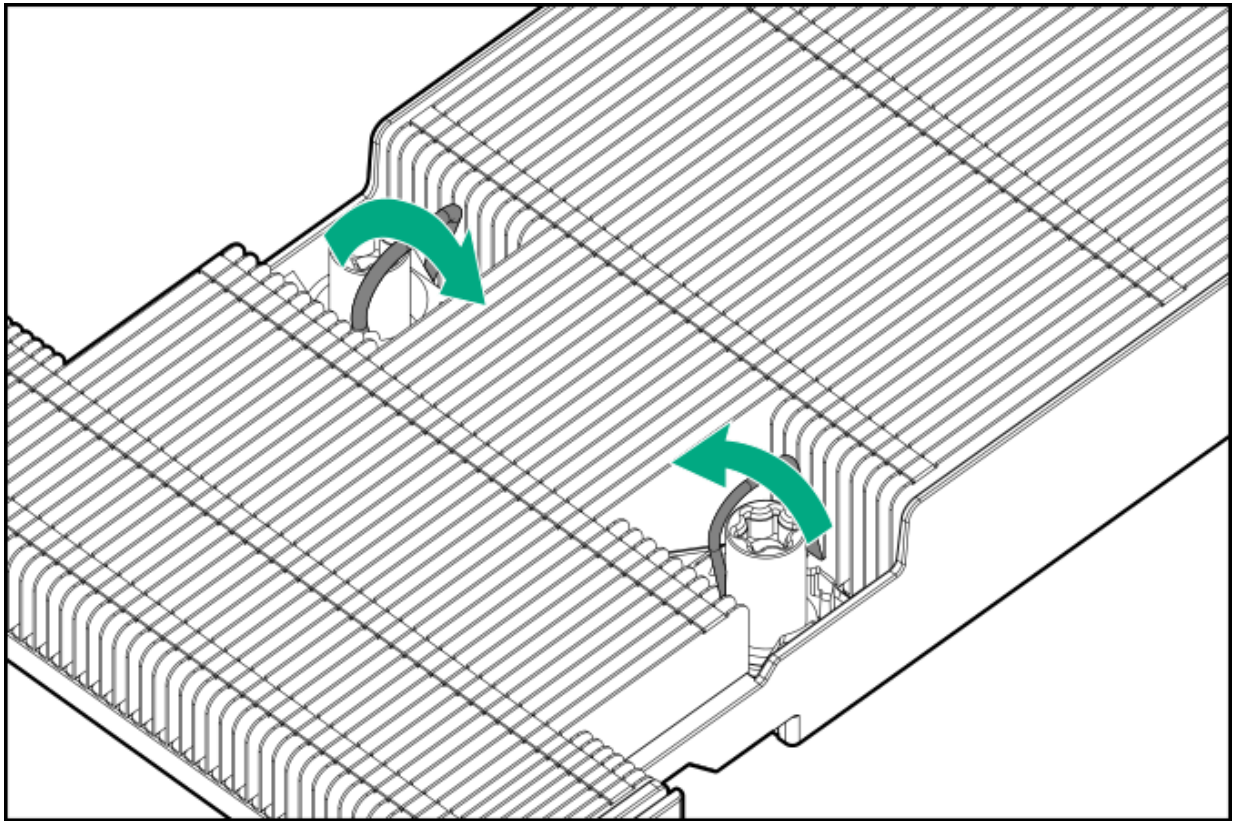

.0.



CAUTION

To prevent mechanical damage or depositing oil on your hands or other contaminants to the heatsink contact surface, hold the heatsink only by the edge of its base plate. Do not touch the heatsink fins.

Lift the processor-heatsink module straight up from the system board.

- Standard heatsink



- High performance heatsink

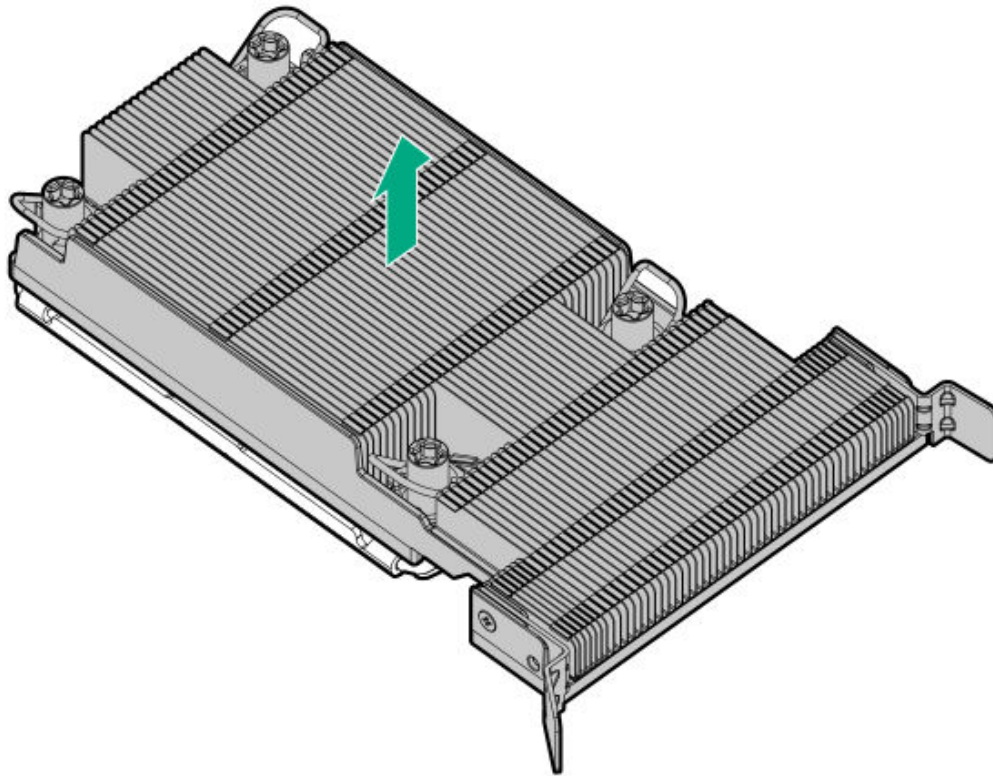

- .1. Place the processor-heatsink module on a flat work surface with its contact side facing up.
- .2. If you are not immediately installing the replacement processor-heatsink module, install the dust cover on the empty processor socket:



CAUTION

Do not press down on the dust cover. Pressing down on the dust cover might damage the processor socket.

- a. Press and hold the grip tabs on the dust cover.
- b. Carefully lower the dust cover onto the bolster plate guide posts.

Make sure that the corner holes of the dust cover are properly engaged with the guide posts on the bolster plate.

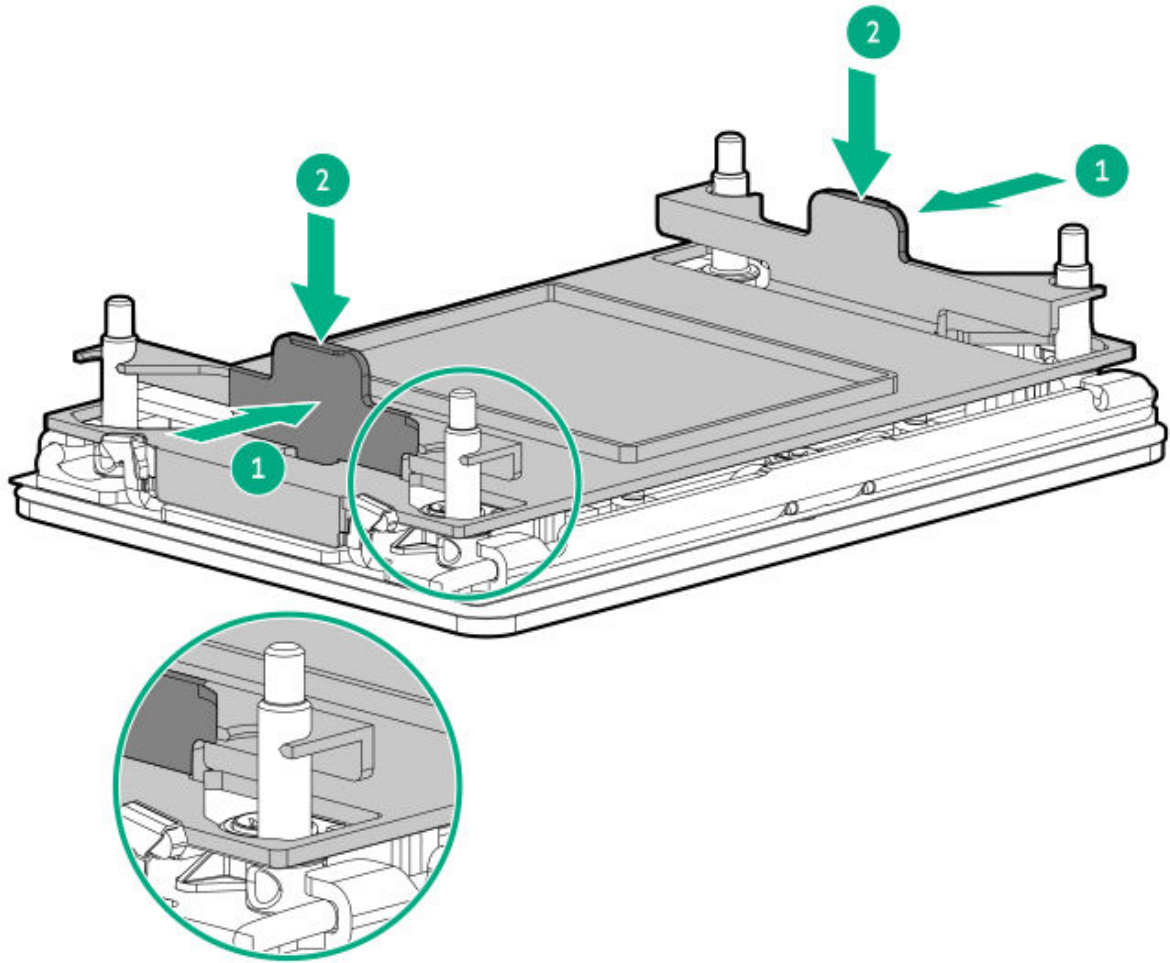

.3. Do not touch the pins on the processor socket and the processor.



CAUTION

THE PINS ON THE PROCESSOR SOCKET AND ON THE PROCESSOR ARE VERY FRAGILE AND EASILY DAMAGED. Any damage to them might require replacing the system board.

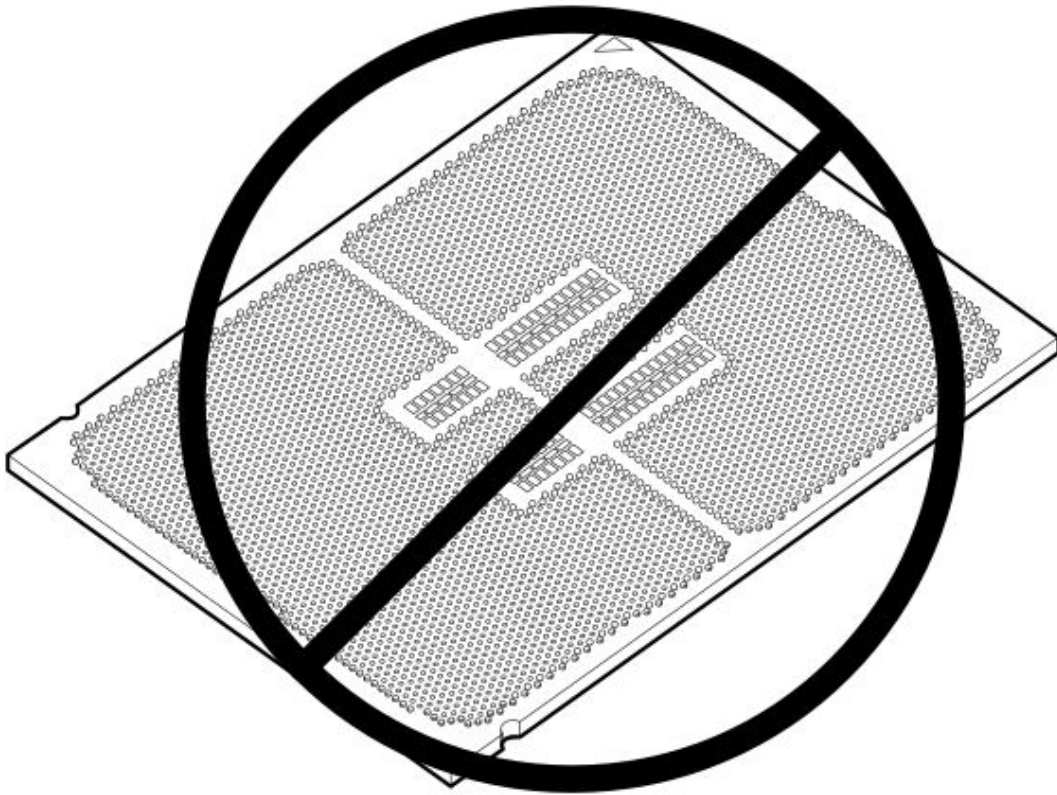
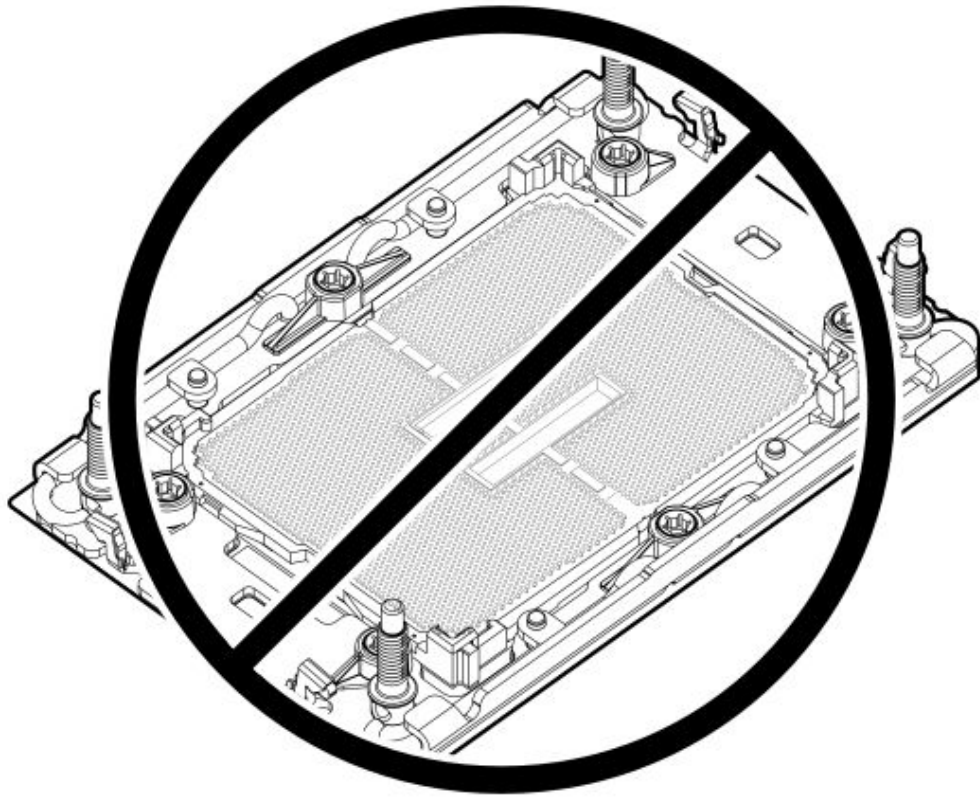

4. Remove the processor from the heatsink:

- a. Open the TIM breaker lever.

This action breaks the adhesion between the processor and the heatsink.

- b. Hold the processor by its edges, and then remove it from the carrier.

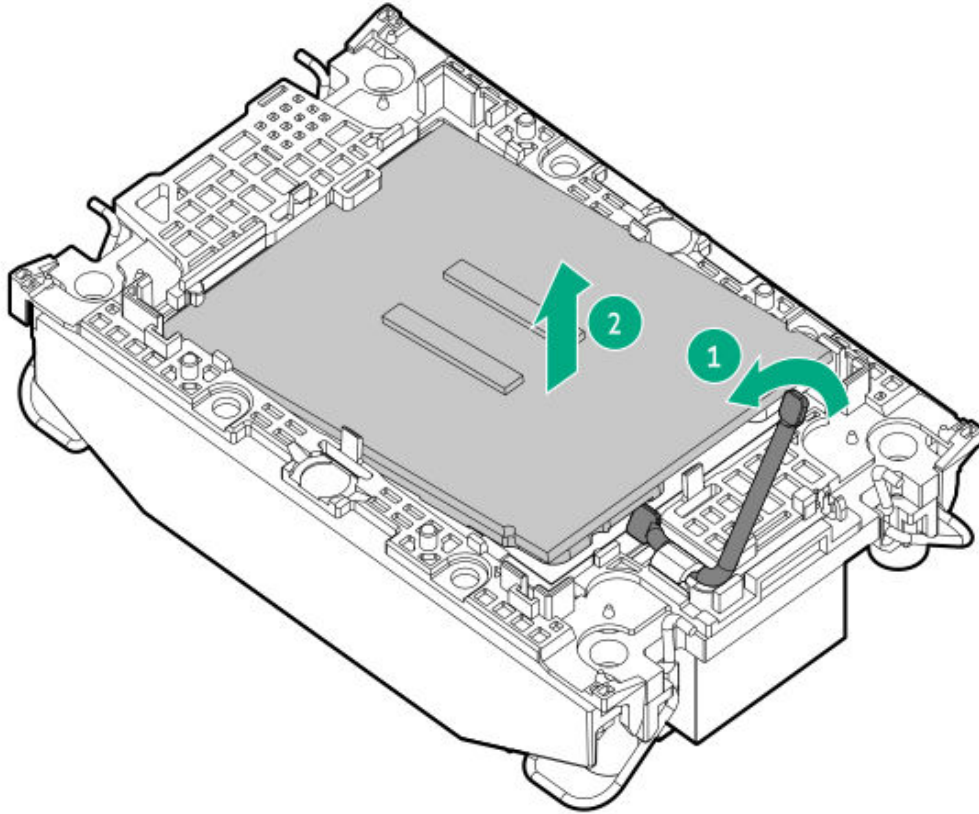

- c. Starting from the pin 1 corner and moving in an opposite manner, disengage the processor carrier release tabs from the heatsink.

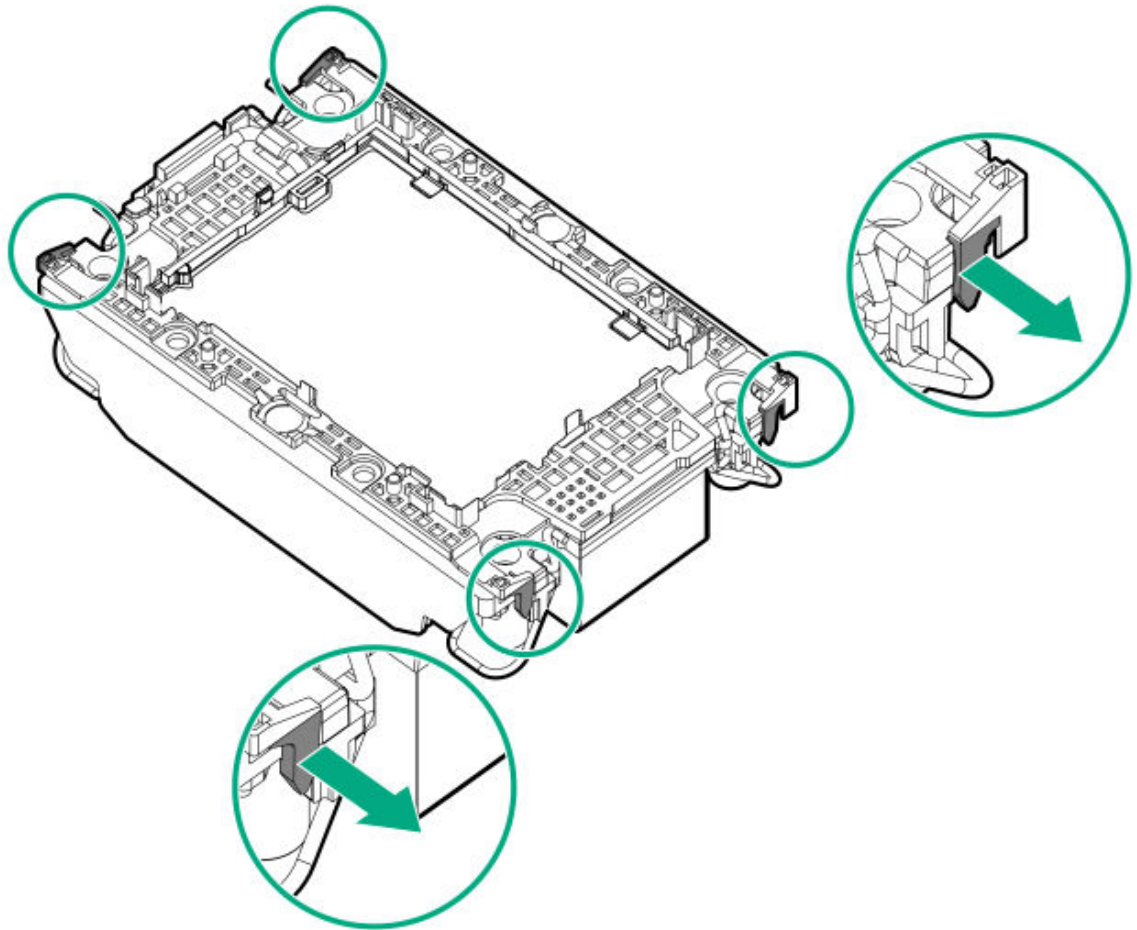

d. Lift the processor carrier away from the heatsink.

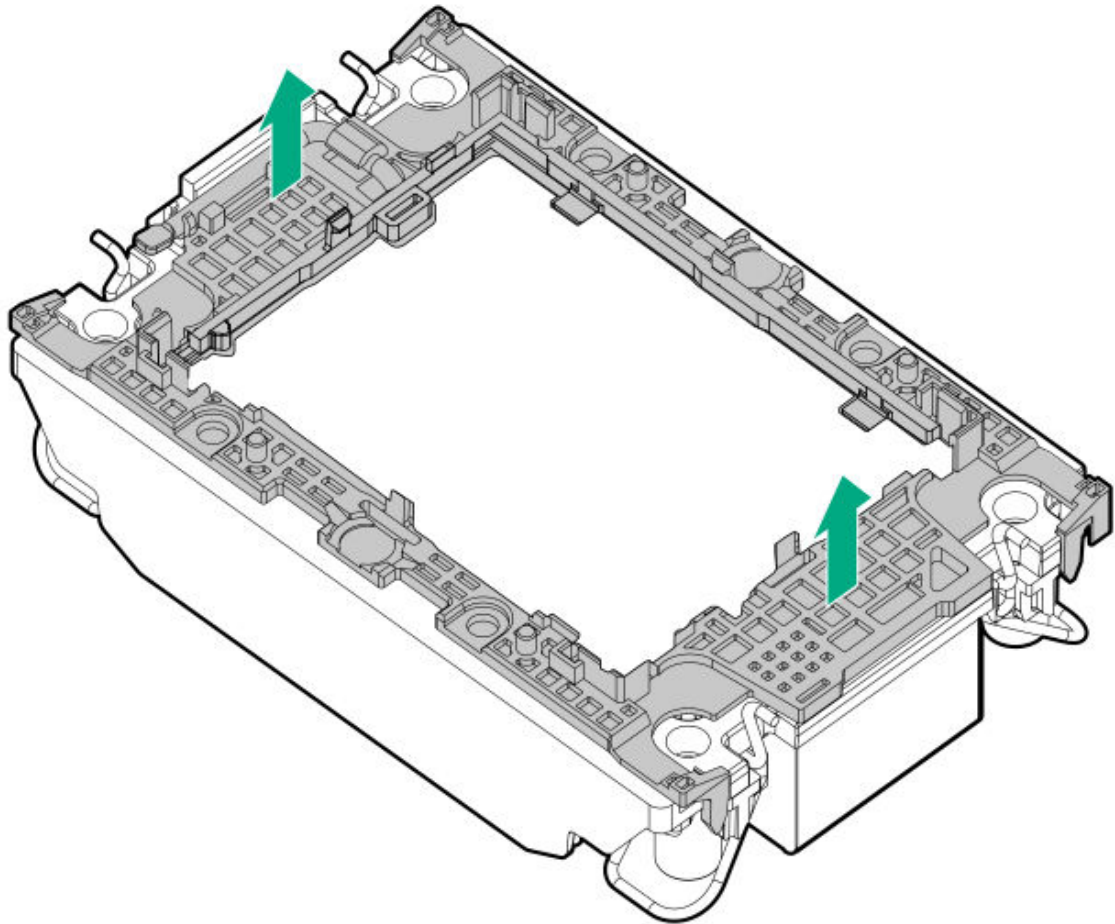

- .5. Using a cleaning solvent, such as alcohol wipes, remove the existing thermal grease from the processor and heatsink.

Allow the alcohol to evaporate before continuing.

Installing a standard or high performance heatsink

Prerequisites

- Review the following
 - [Processor cautions](#)
 - [Heatsink and processor socket components](#)
 - [Fan and heatsink requirements](#)

- Before you perform this procedure, make sure that you have a T-30 Torx screwdriver or a torque screwdriver with T-30 Torx bit available.

About this task



CAUTION

A discharge of static electricity from a finger or other conductor might damage system boards or other static-sensitive devices. To prevent damage, observe antistatic precautions.

Procedure

1. Do not touch the pins on the processor socket and the processor.



CAUTION

THE PINS ON THE PROCESSOR SOCKET AND ON THE PROCESSOR ARE VERY FRAGILE AND EASILY DAMAGED. Any damage to them might require replacing the system board.

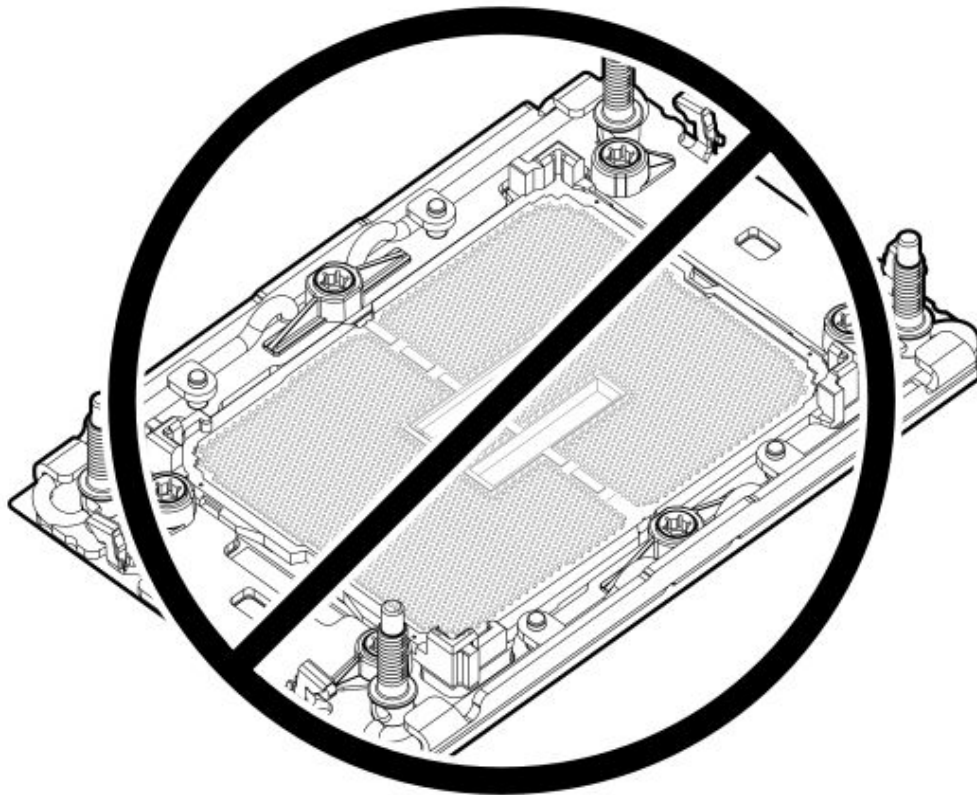

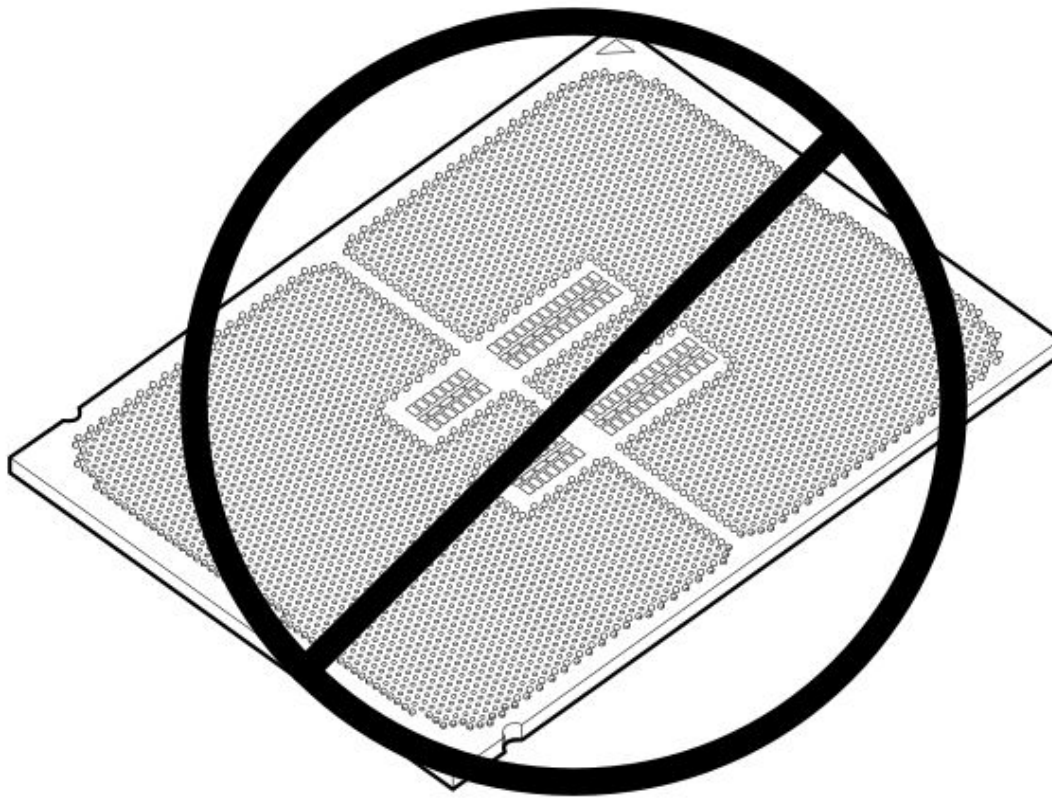

2. If you are using the same heatsink, apply the full content of the thermal grease syringes on top of the processor. Follow the pattern shown in the following image.

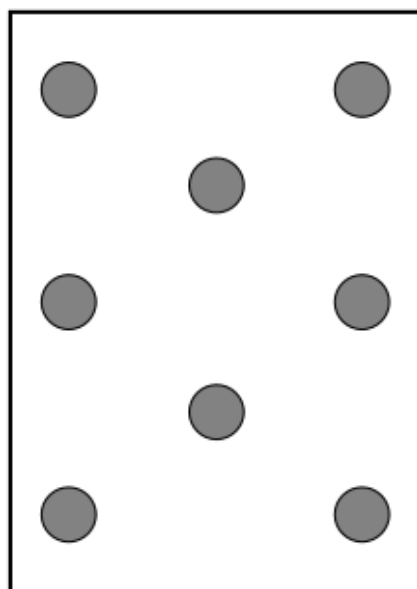

3. If you are using a new heatsink, remove the protective film from the thermal interface material.

- Standard heatsink

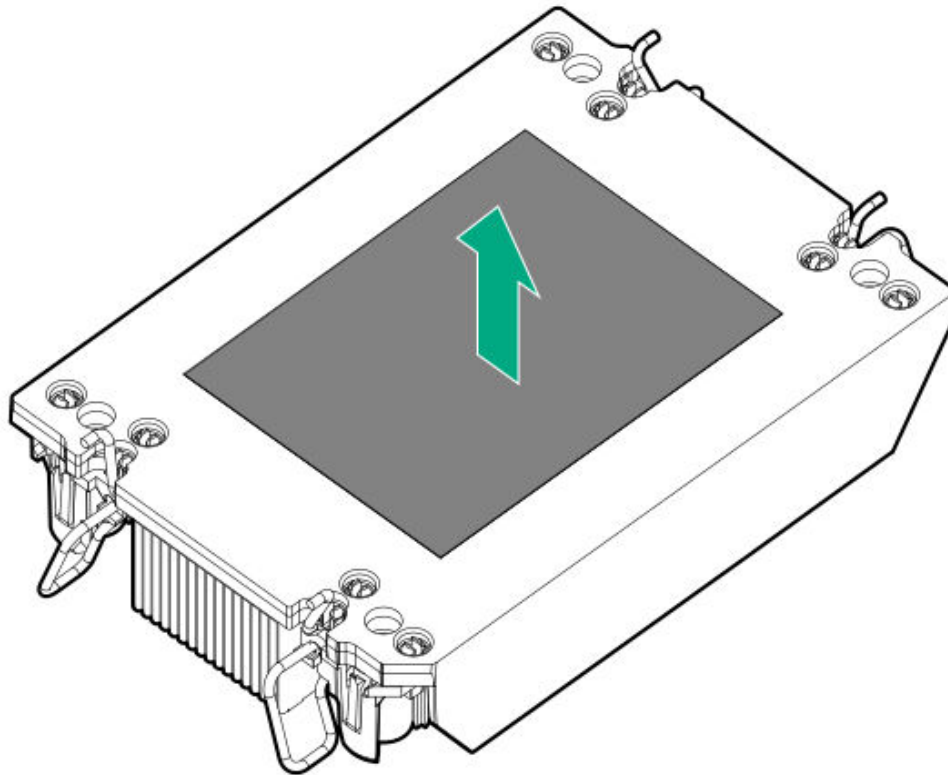

- High performance heatsink

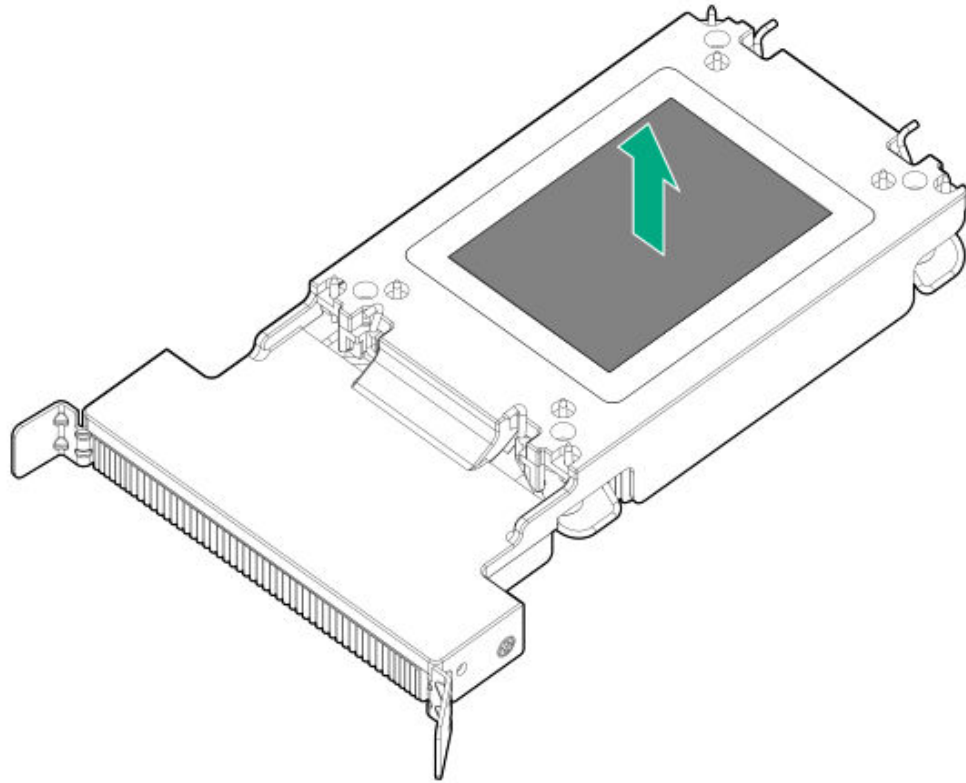

4. Set the anti-tilt wires to the locked position.



5. Install the processor carrier on the processor:
 - a. Align the pin 1 indicator on the processor carrier with that on the processor, and then press on the pair of opposite sides on the TIM breaker lever of the processor carrier until it clicks into place.

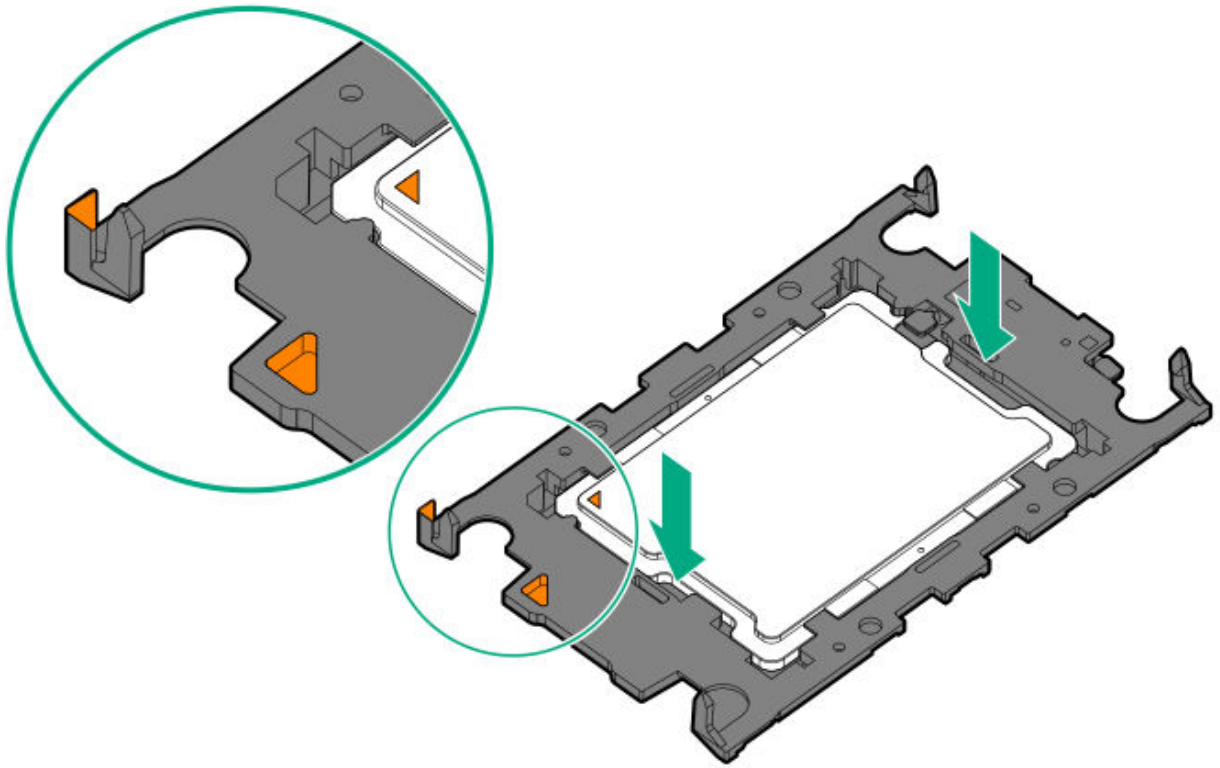

b. Verify that the processor is properly latched on the processor carrier.

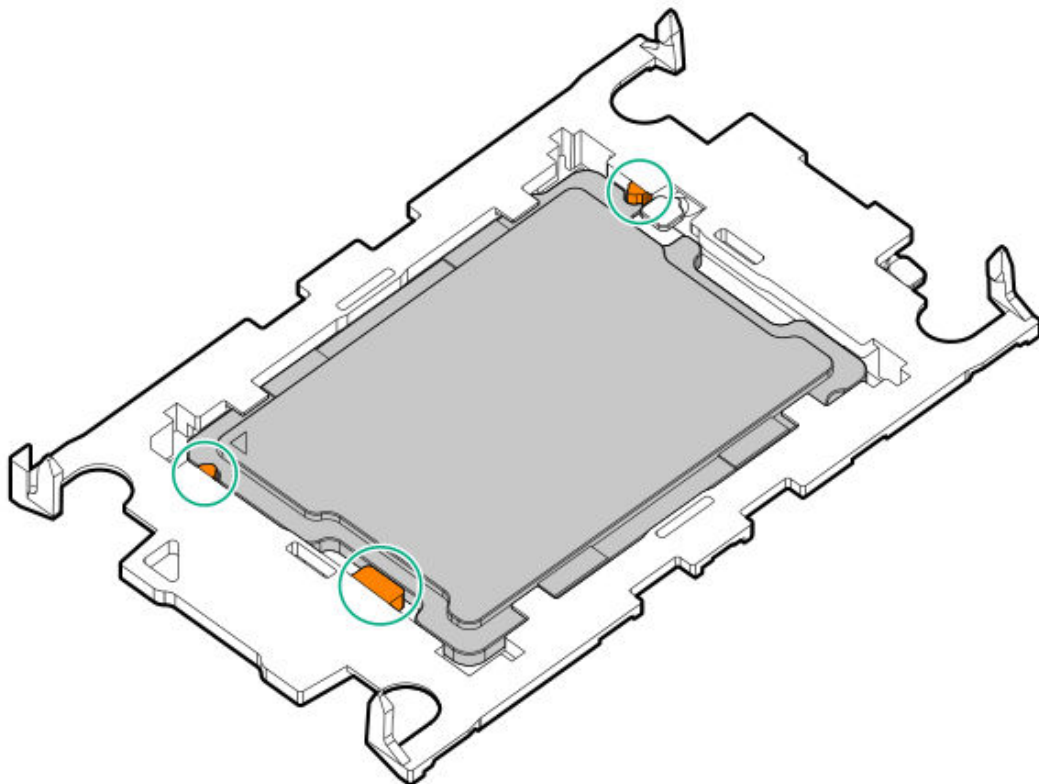

If not, press the other pair of opposite sides of the processor carrier until it clicks into place.

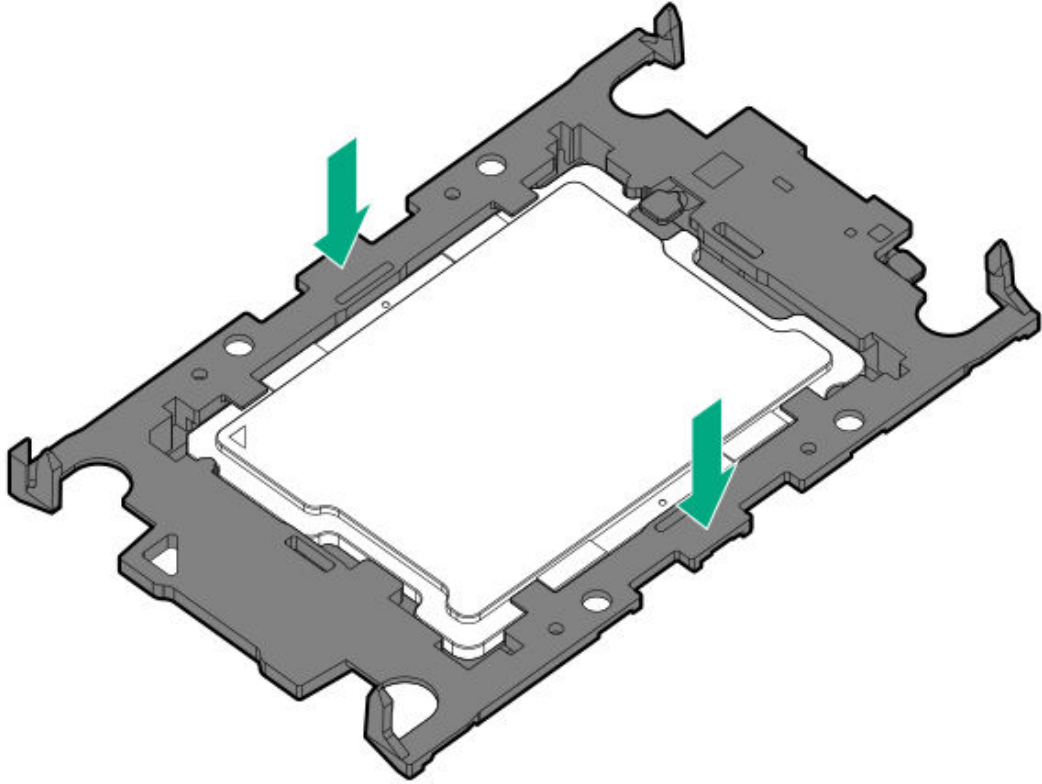

6. Attach the heatsink to the processor carrier:

a. Align the pin 1 indicator on the processor carrier with that on the heatsink.

- Standard heatsink

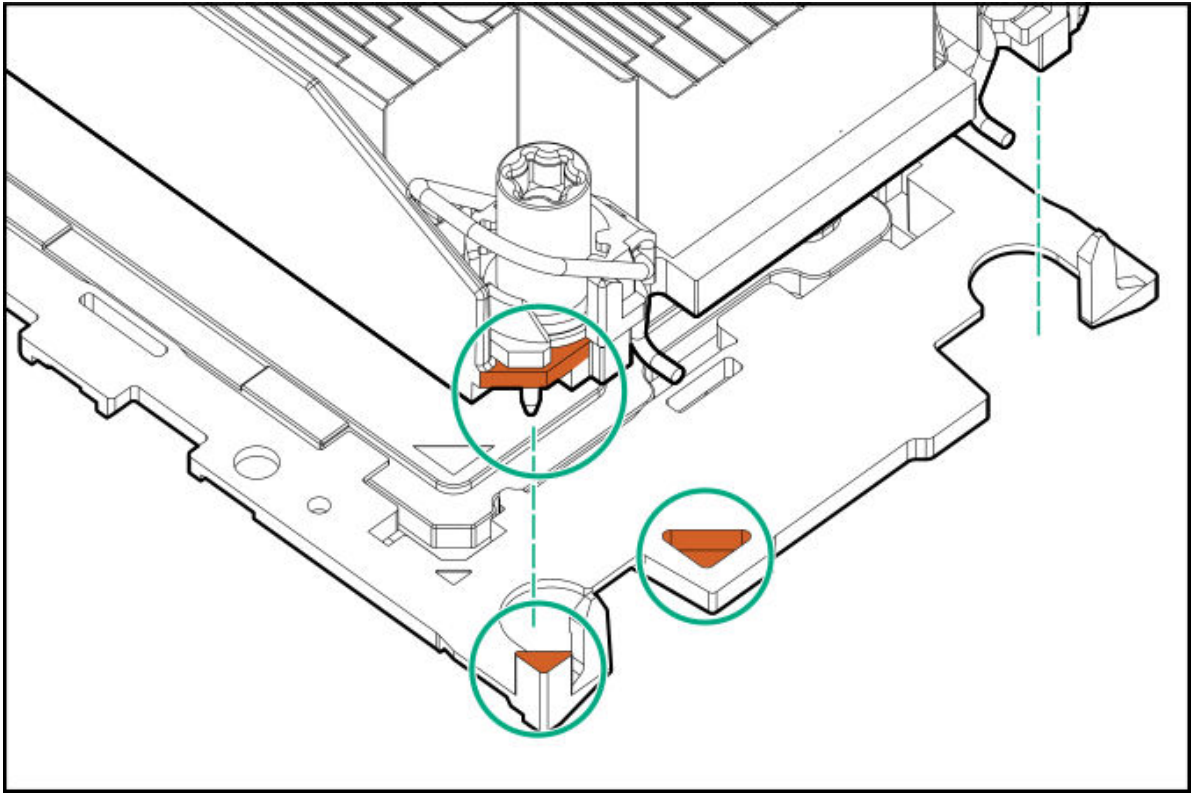

- High performance heatsink

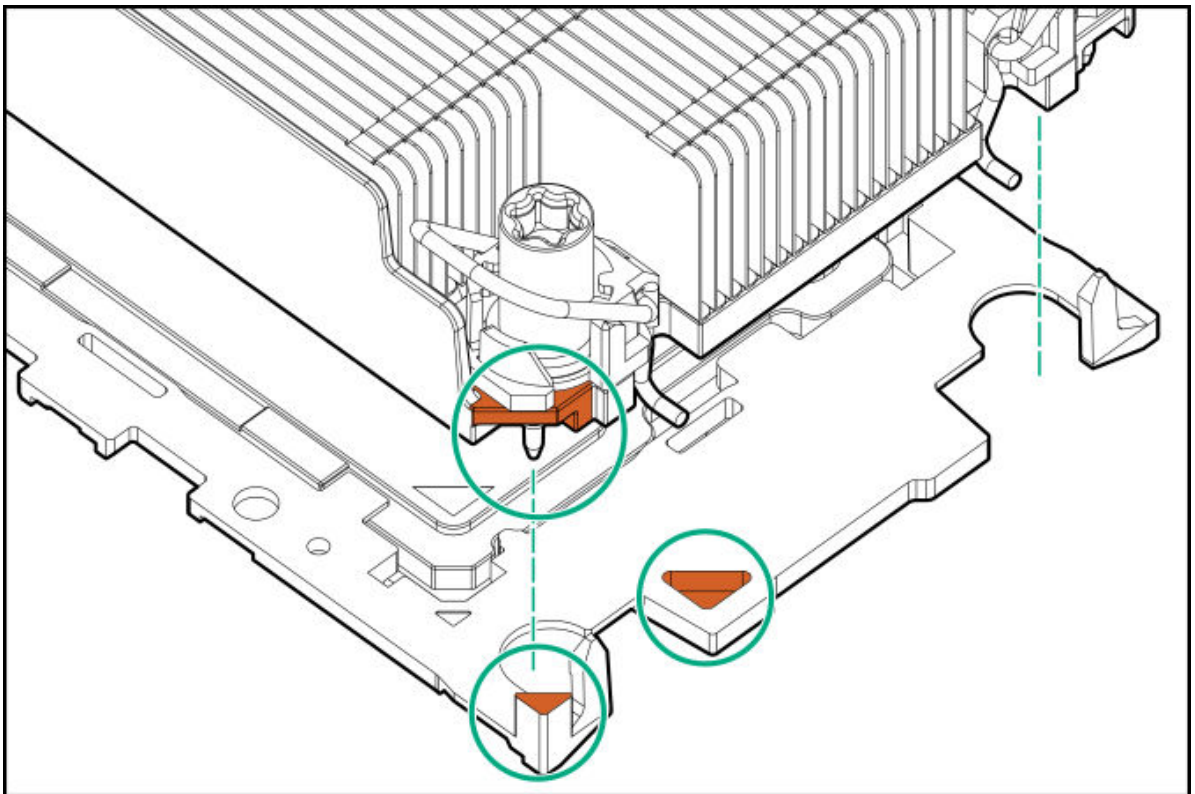

b. Lower the heatsink on the processor carrier until the carrier tabs snap into place.

There will be an audible click to indicate that the heatsink is properly latched on the processor carrier.

- Standard heatsink

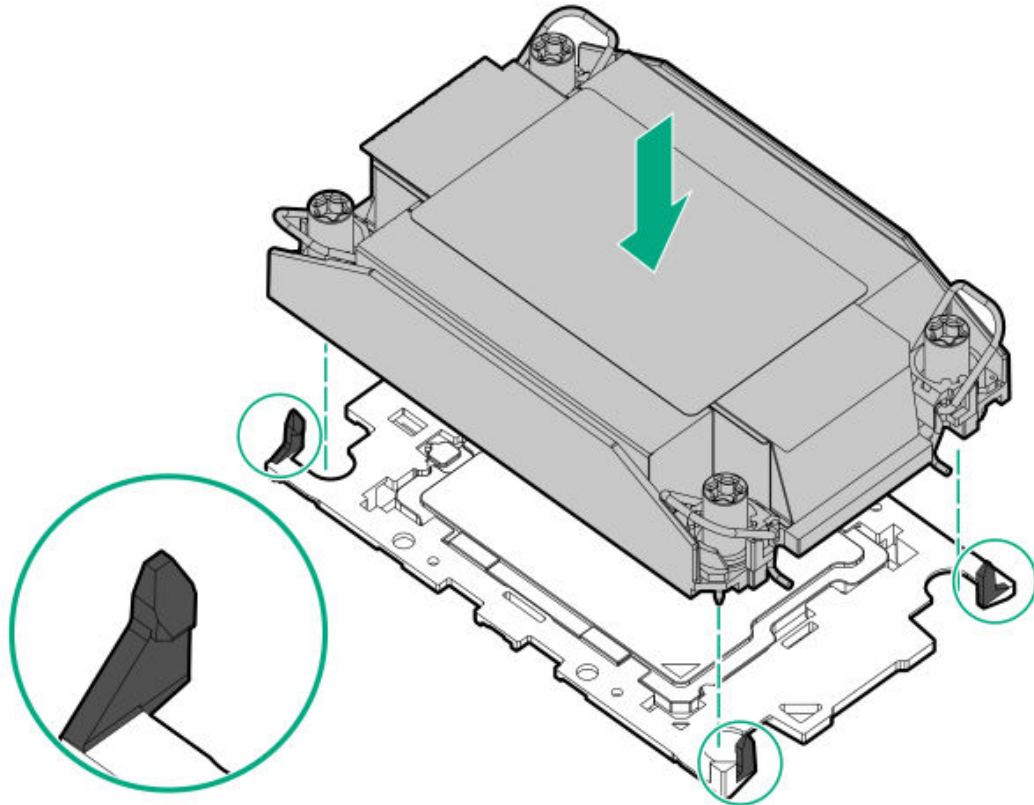

- High performance heatsink

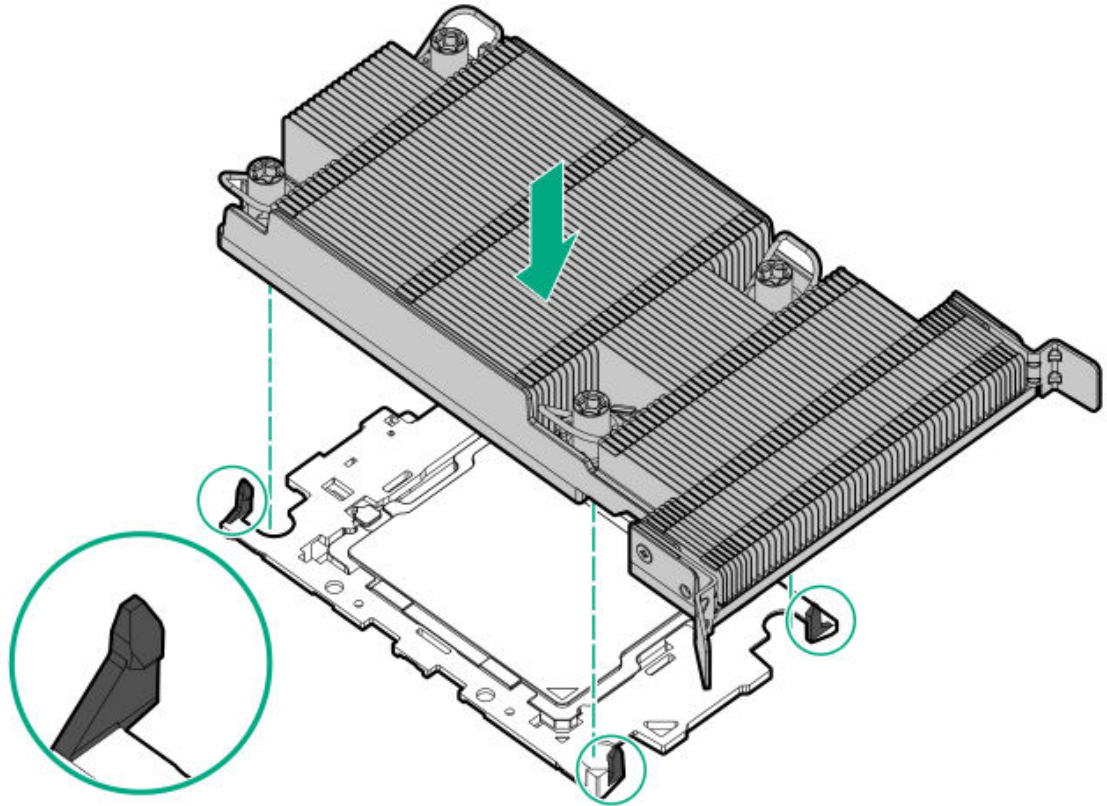

7. Perform the following verification steps:

a. Verify that the tabs on the processor carrier are securely latched on the heatsink.

- Standard heatsink

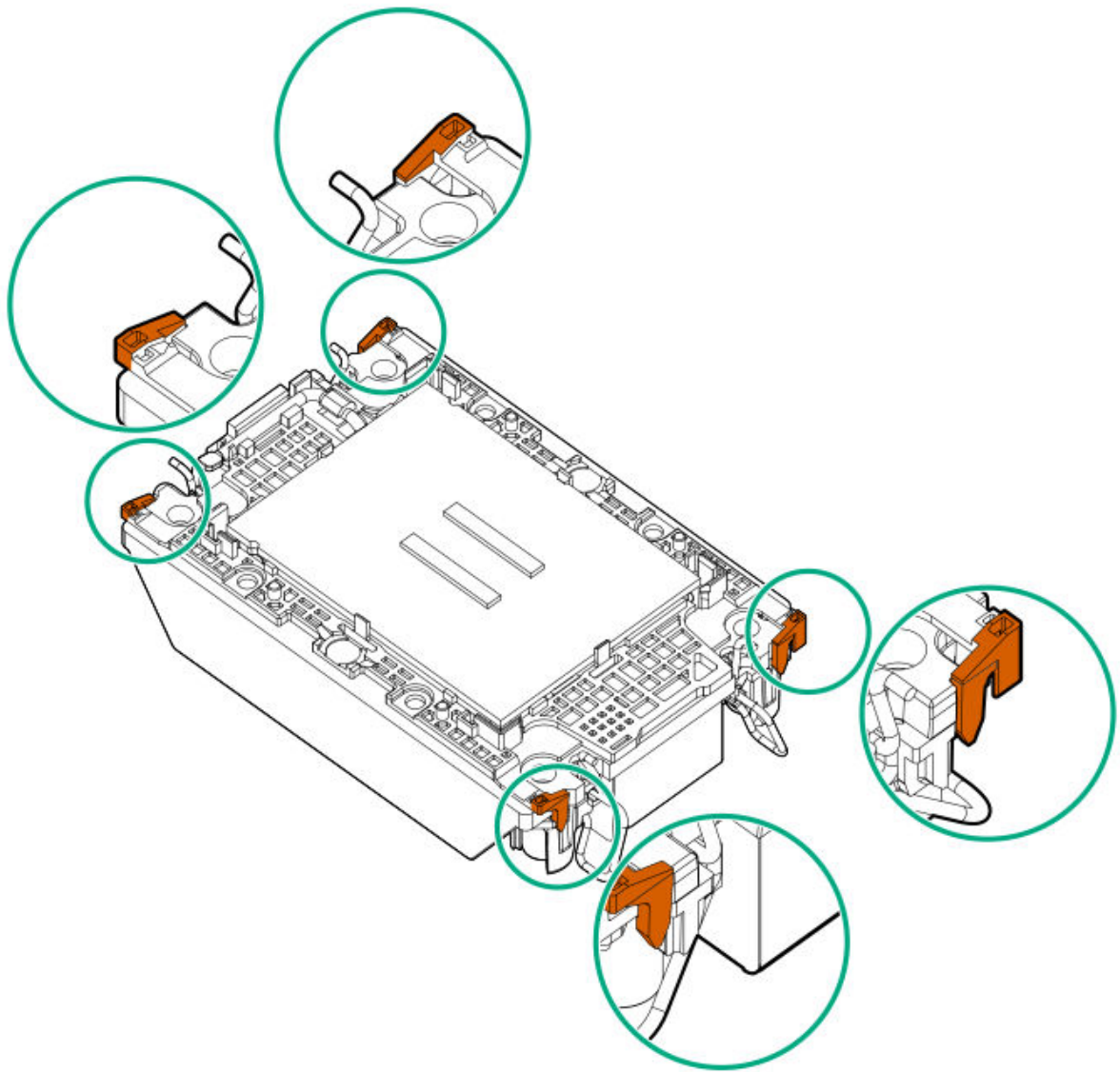

- High performance heatsink

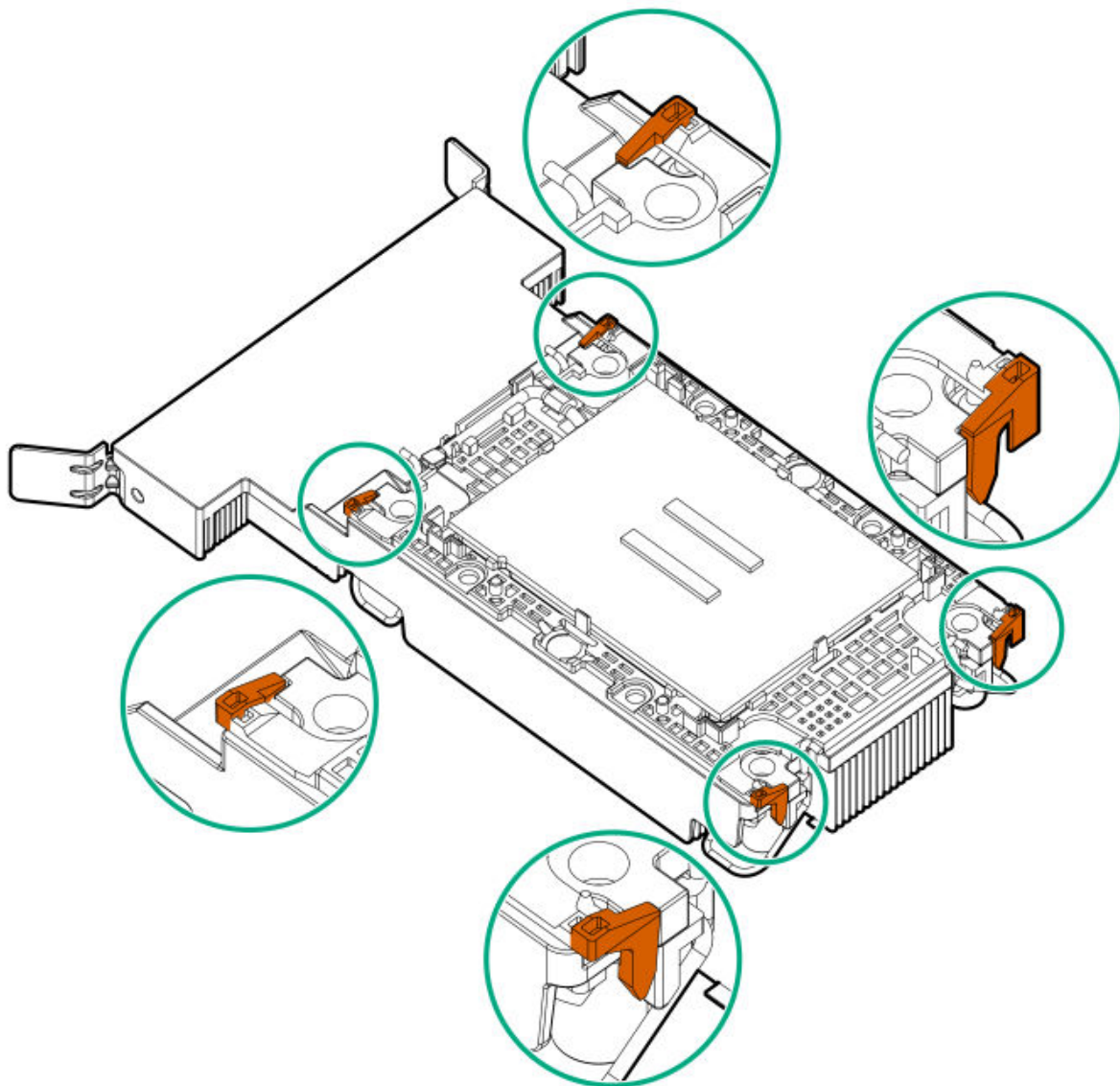

b. Verify that the pin 1 indicators on the processor and processor carrier are aligned.

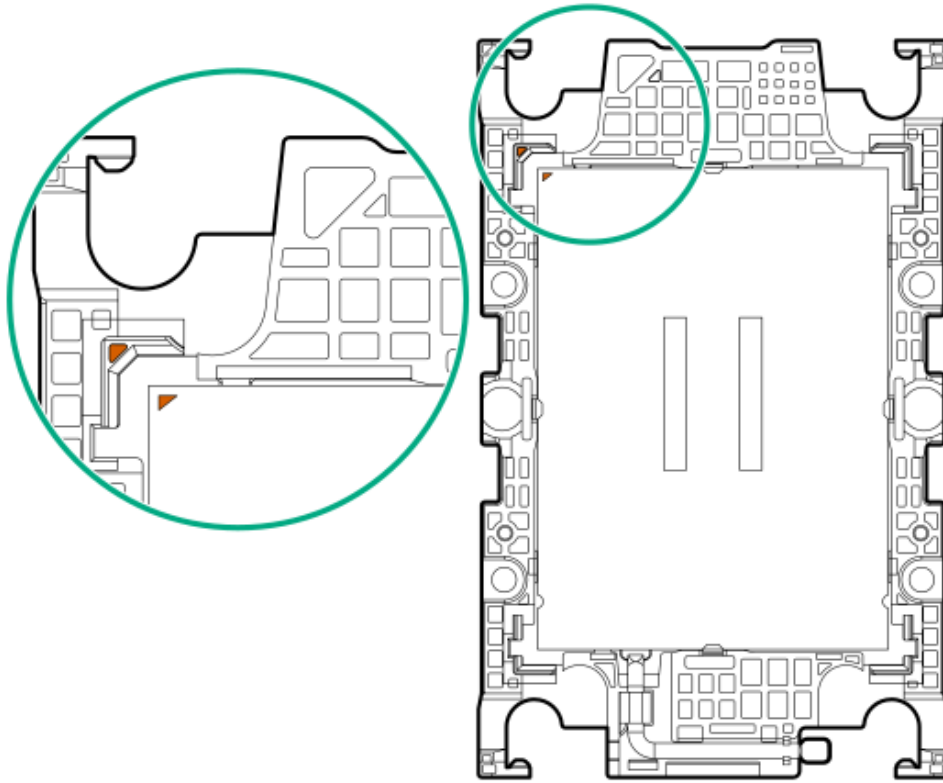

c. Verify that the processor is properly secured by the carrier snaps.

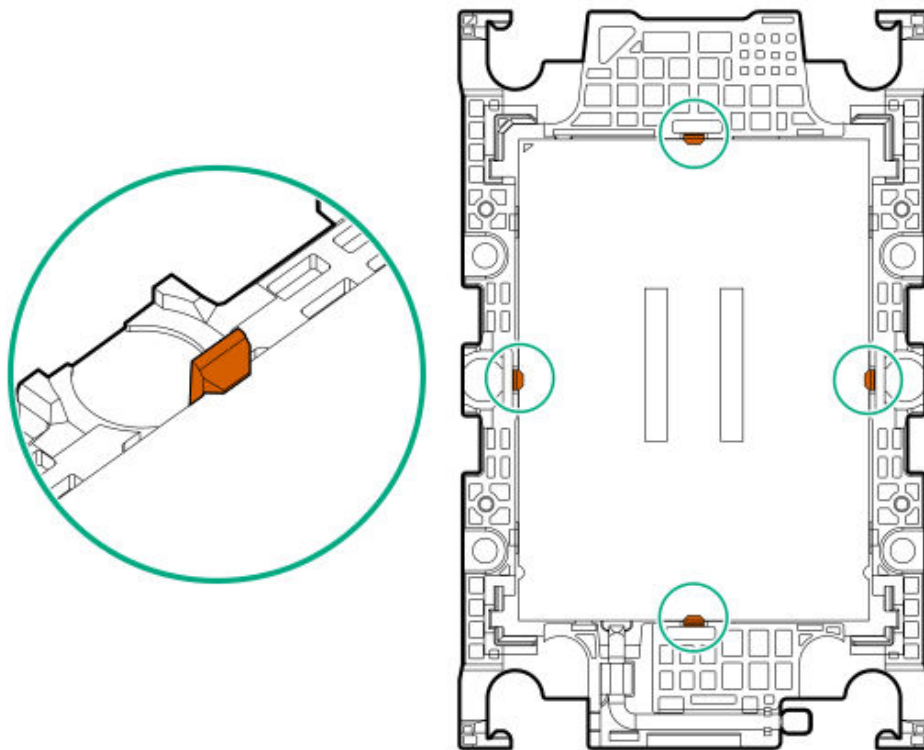

- Set the anti-tilt wires to the unlocked position.



9.



CAUTION

To prevent thermal failure or component damage, do not move the heatsink once the bottom of its base plate touches the top of the processor. Excessive heatsink movement can cause the thermal grease to smear and become uneven. Voids in the compound can adversely impact the transfer of heat away from the processor.

Install the processor-heatsink module:

- When using a torque wrench to tighten the heatsink screws, set 0.9 N-m (8 in-lb) of torque.
- Note the **Front of server** text on the heatsink label to correctly orient the processor-heatsink module over the bolster plate.
- Carefully lower the processor-heatsink module onto the bolster plate guide posts.

The posts are keyed so that the module can only be installed one way. Make sure that the module is properly seated on the bolster plate before securing the screws.

- Standard heatsink

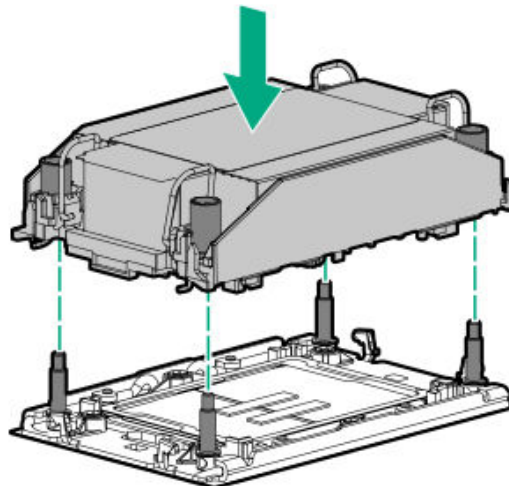

- High performance heatsink

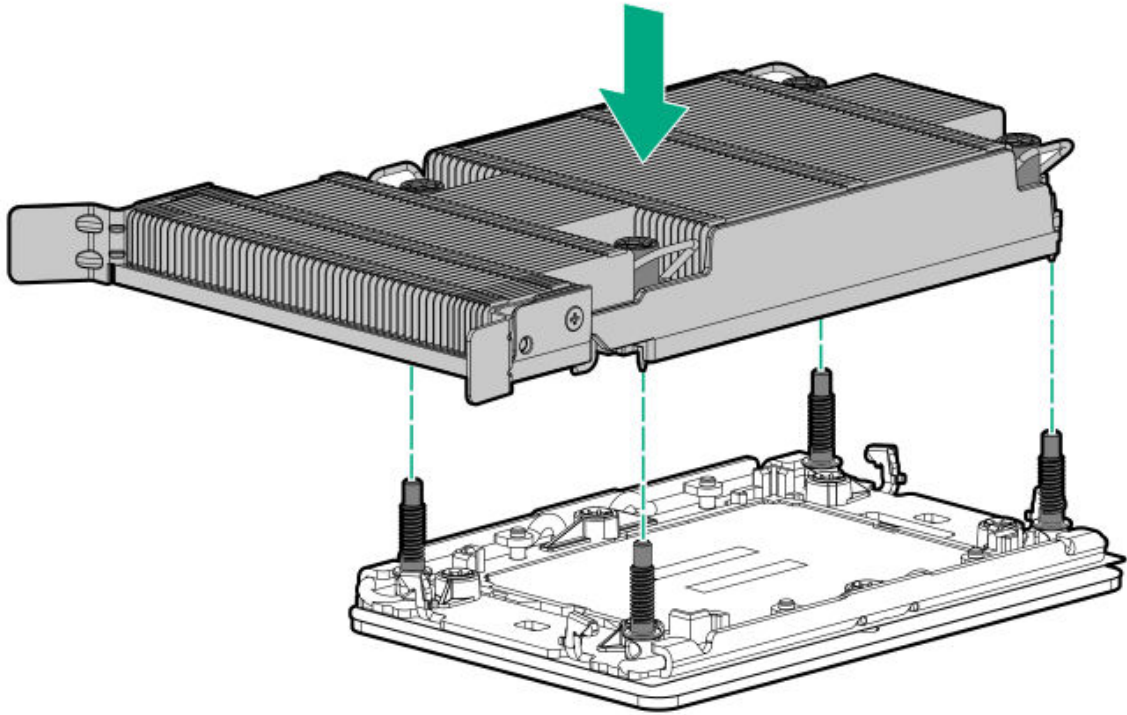

d. Set the anti-tilt wires to the locked position.



e. Tighten one pair of diagonally opposite heatsink screws, and then tighten the other pair of heatsink screws.

- Standard heatsink

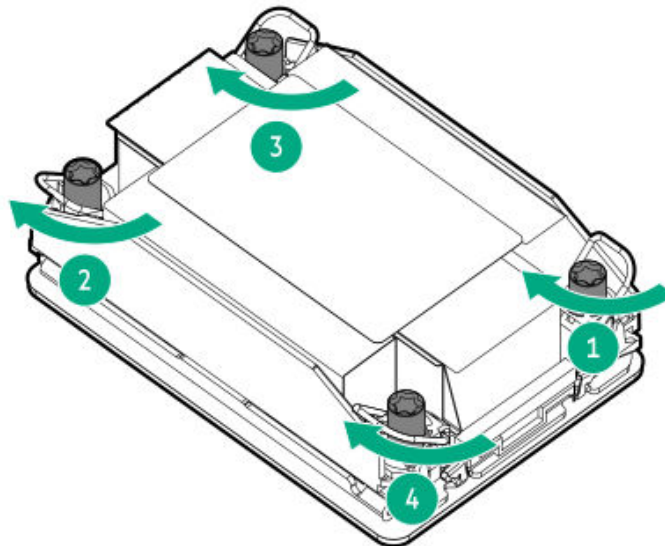

- High performance heatsink

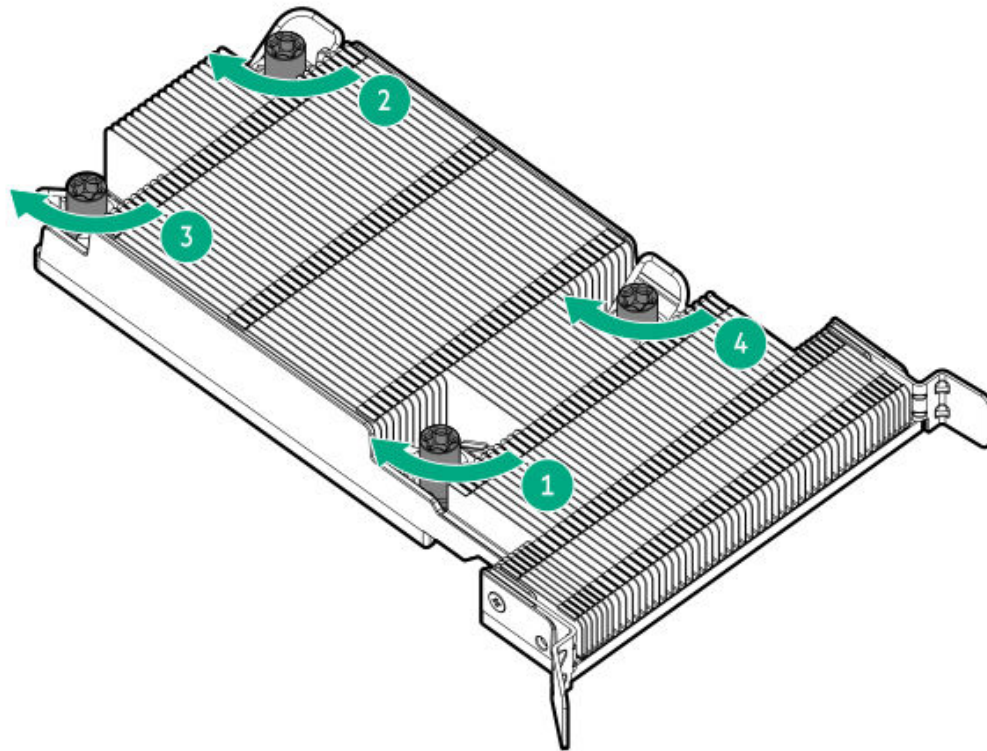

.0. (Optional) Install the air baffle.

The air baffle is supported only when the system is configured with high performance heatsinks.

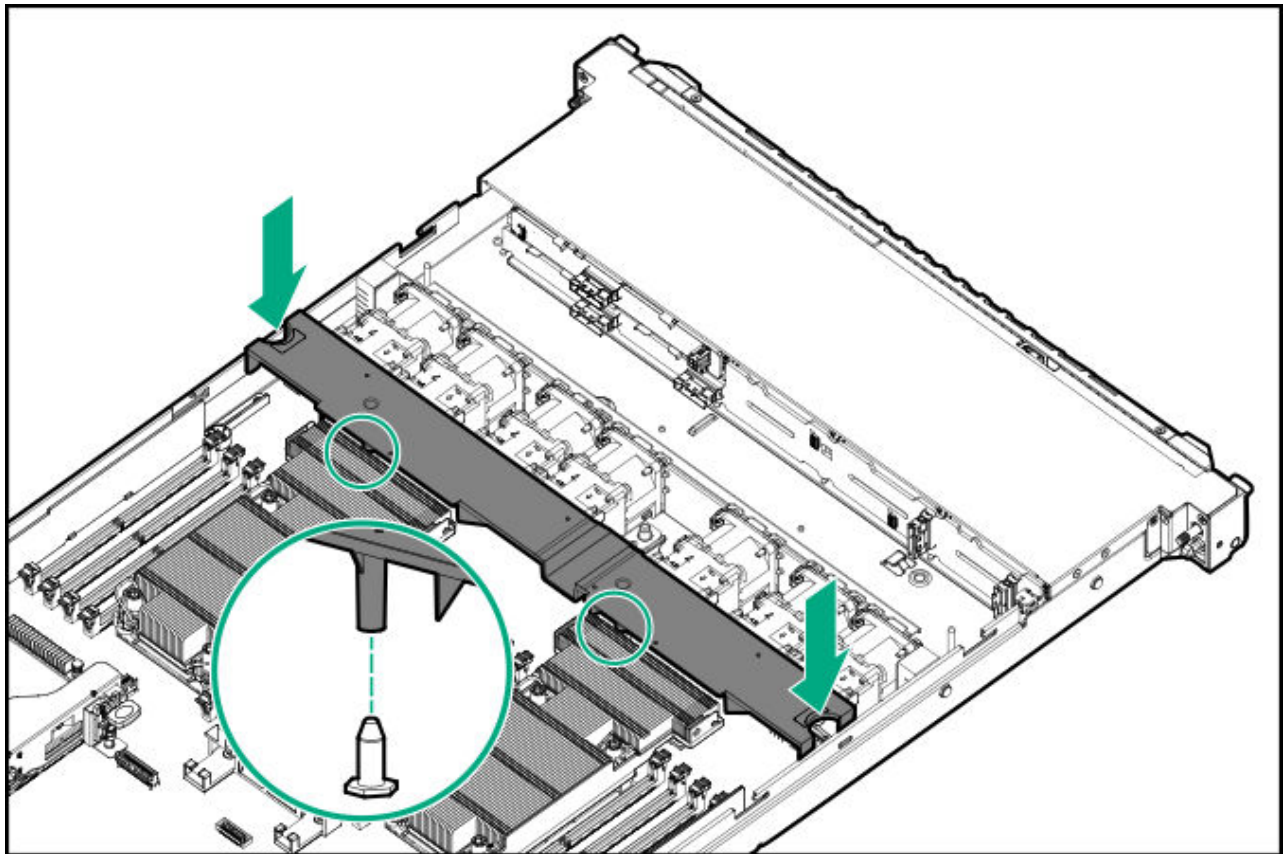

- .1. Install the access panel.
- .2. If the server was removed from an enclosure or a rack, reinstall it now.
- .3. Connect all peripheral cables to the server.
- .4. Connect each power cord to the server.
- .5. Connect each power cord to the power source.
- .6. Power up the server.

Results

The replacement procedure is complete.

Liquid cooling module replacement

Subtopics

Removing the closed-loop liquid cooling module from the system board

Installing the closed-loop liquid cooling module on the system board

Disconnecting the direct liquid cooling kit

Removing the DLC cold plate module from the system board

Installing the DLC cold plate module on the system board

Removing the closed-loop liquid cooling module from the system board

Prerequisites

- Review the following:
 - [Closed-loop liquid cooling \(CLLC\) module components](#)
 - [Heatsink and processor socket components](#)
 - [Processor cautions](#)
 - [Eye and skin protection](#)
- If the reason for replacing the liquid cooling module is due to a coolant leak, first perform the [Appendix I: Server coolant spill response procedure](#).
- Before you perform this procedure, make sure that you have the following items available:
 - Liquid cooling module handle that ships with the closed-loop liquid cooling module spare part
 - T-30 Torx screwdriver or a bit driver with T-30 Torx bit
 - T-15 Torx screwdriver
 - Alcohol wipe
 - Processor socket dust cover—This is needed if you are not immediately installing the replacement processor-heatsink assembly.

About this task

<https://sketchfab.com/models/d096d52d718341fca85a81295ca4b374/embed?>



WARNING

To reduce the risk of personal injury from hot surfaces, allow the drives and the internal system components to cool before touching them.



CAUTION

A discharge of static electricity from a finger or other conductor might damage system boards or other static-sensitive devices. To prevent damage, observe antistatic precautions.

Procedure

1. Power down the server.
2. Remove all power:
 - a. Disconnect each power cord from the power source.
 - b. Disconnect each power cord from the server.
3. Disconnect all peripheral cables from the server.
4. If the server is installed in an enclosure or a rack, remove the server and place it on a flat and level work surface.
5. Remove the access panel.
6. Remove all fans.

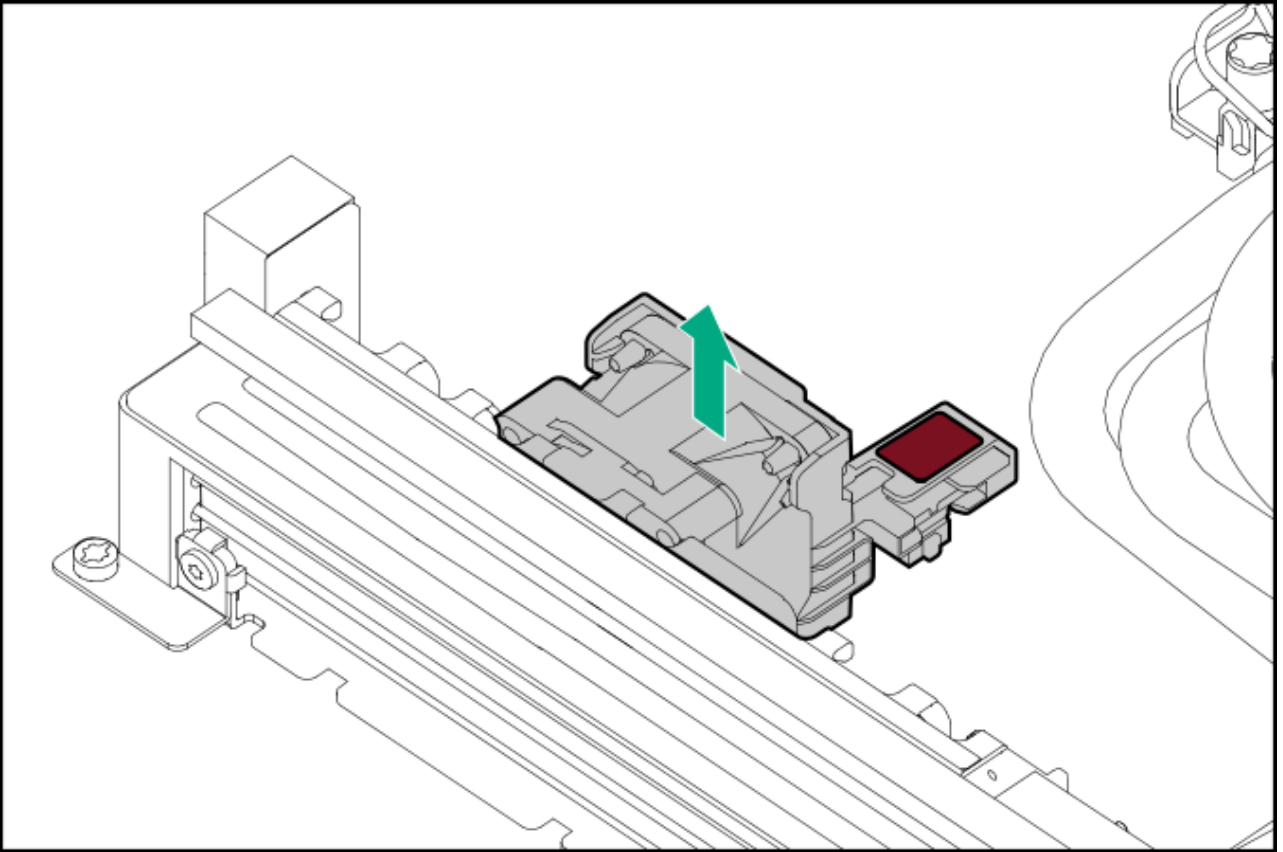

7. Remove the access panel guide pin.

Retain the guide pin. The guide pin will be re-installed after the new liquid cooling module is installed.

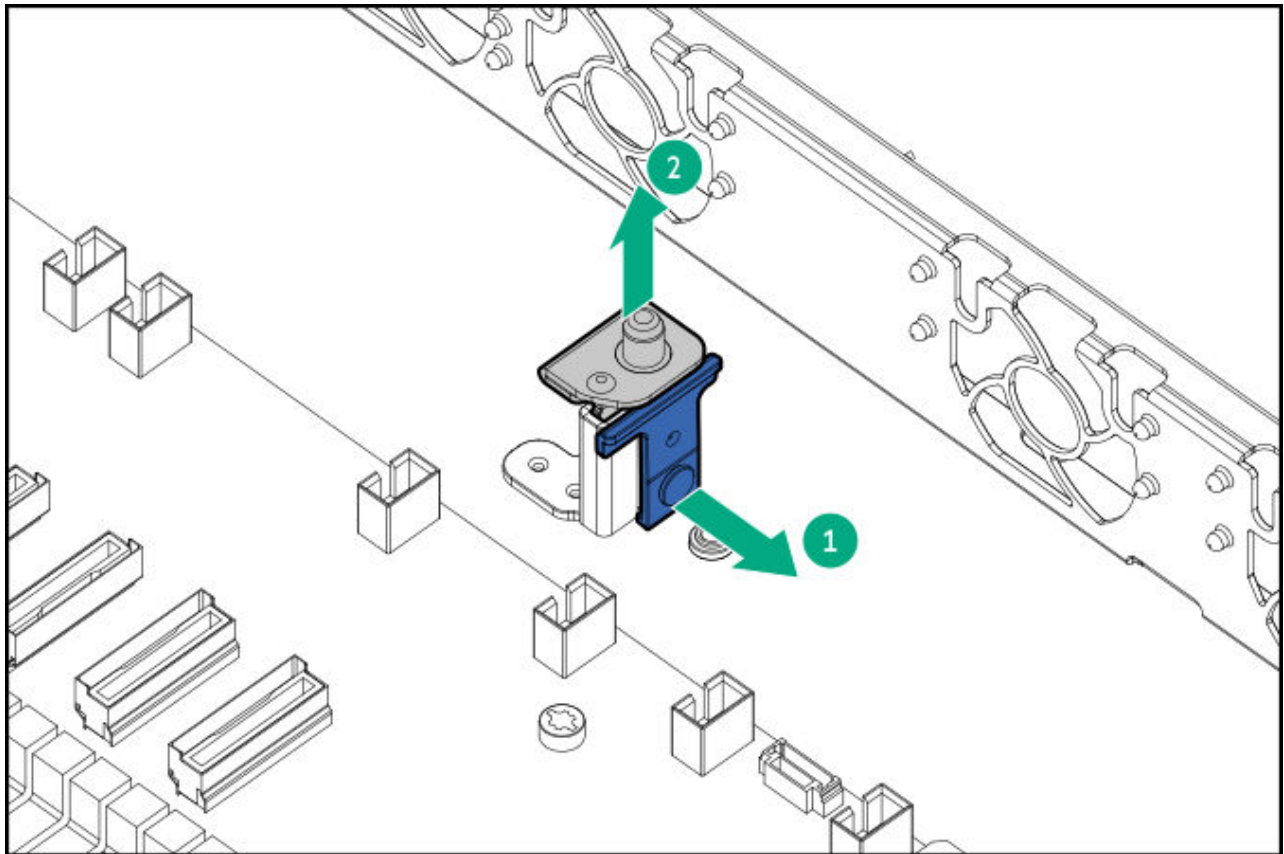

8. Set the liquid cooling module handle to the appropriate length.
 - a. Disengage the locking handle.
 - b. Extend the handle and align the edge to the line marked by the letter E.
 - c. Engage the locking handle.

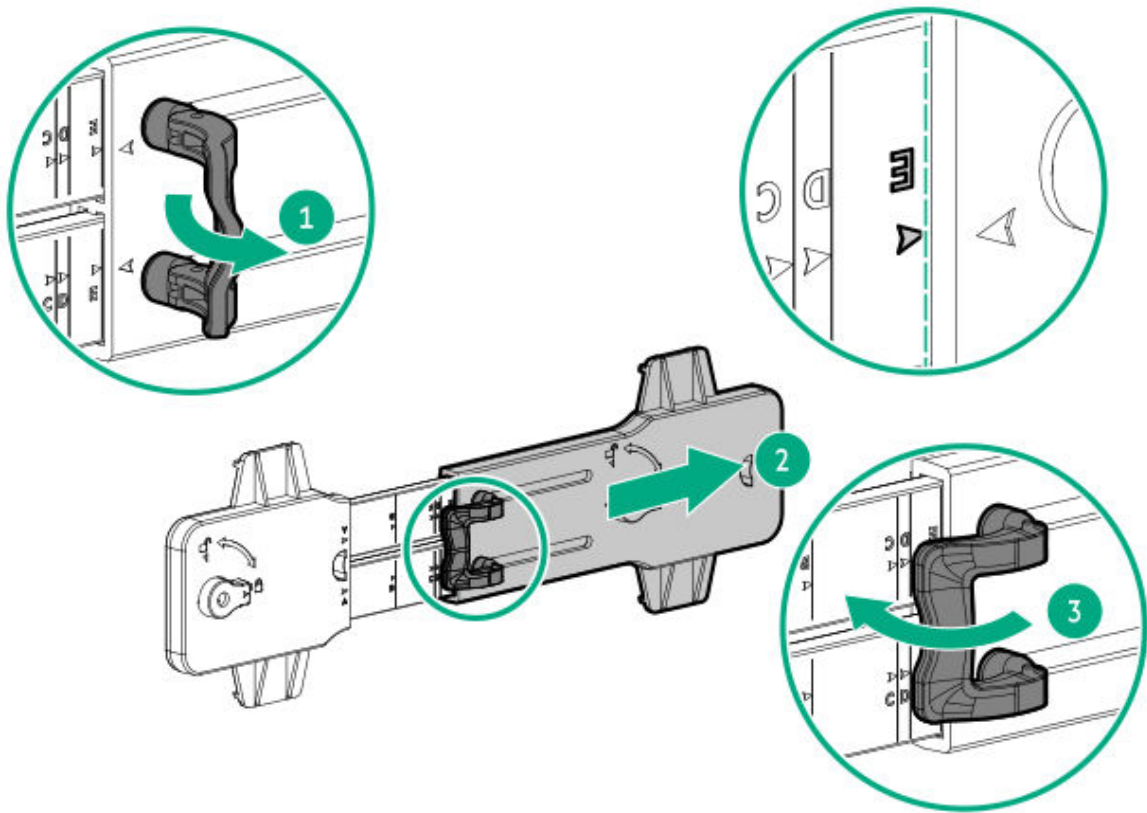

9. Attach the handle to the pump-cold plates:

- a. Rotate the handle knobs anti-clockwise to the unlocked position.

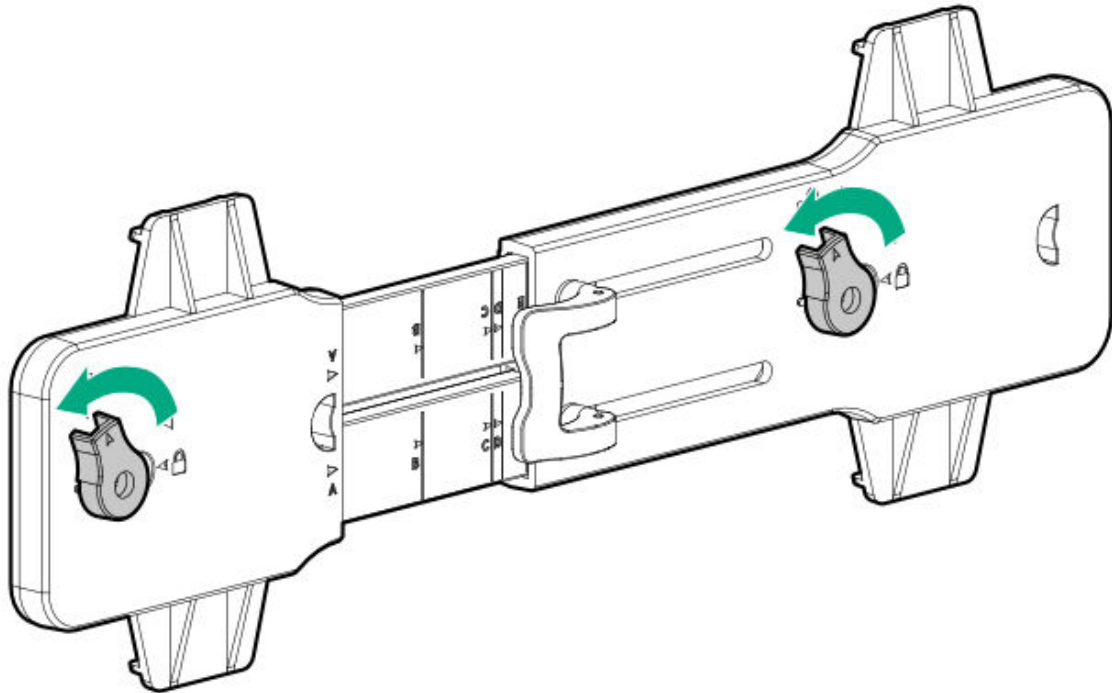

- b. Align the hooks on the handle with the notches on the pump-cold plates, and then attach the handle to the pump-cold plates.

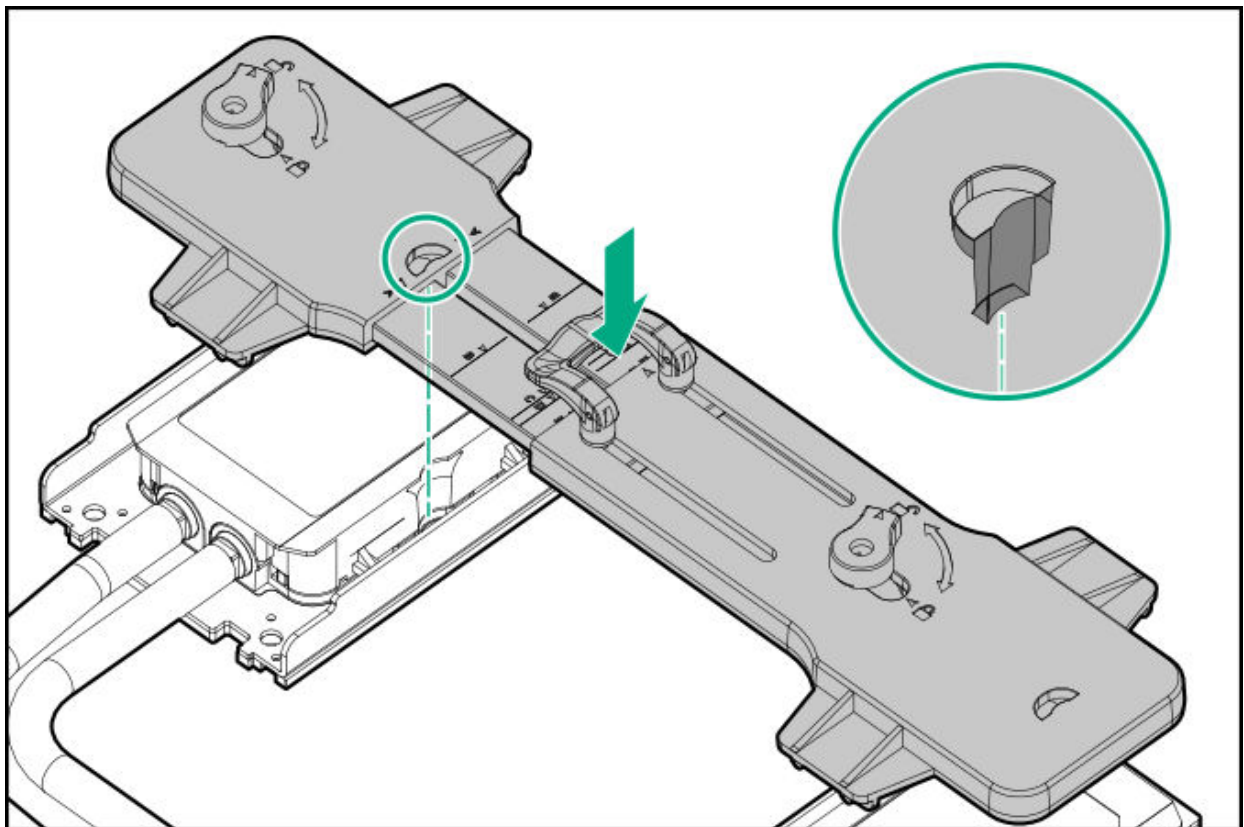

- c. Turn the handle knobs to the locked position.

Gently pull on the handle and verify that pump-cold plates are securely latched to the handle.

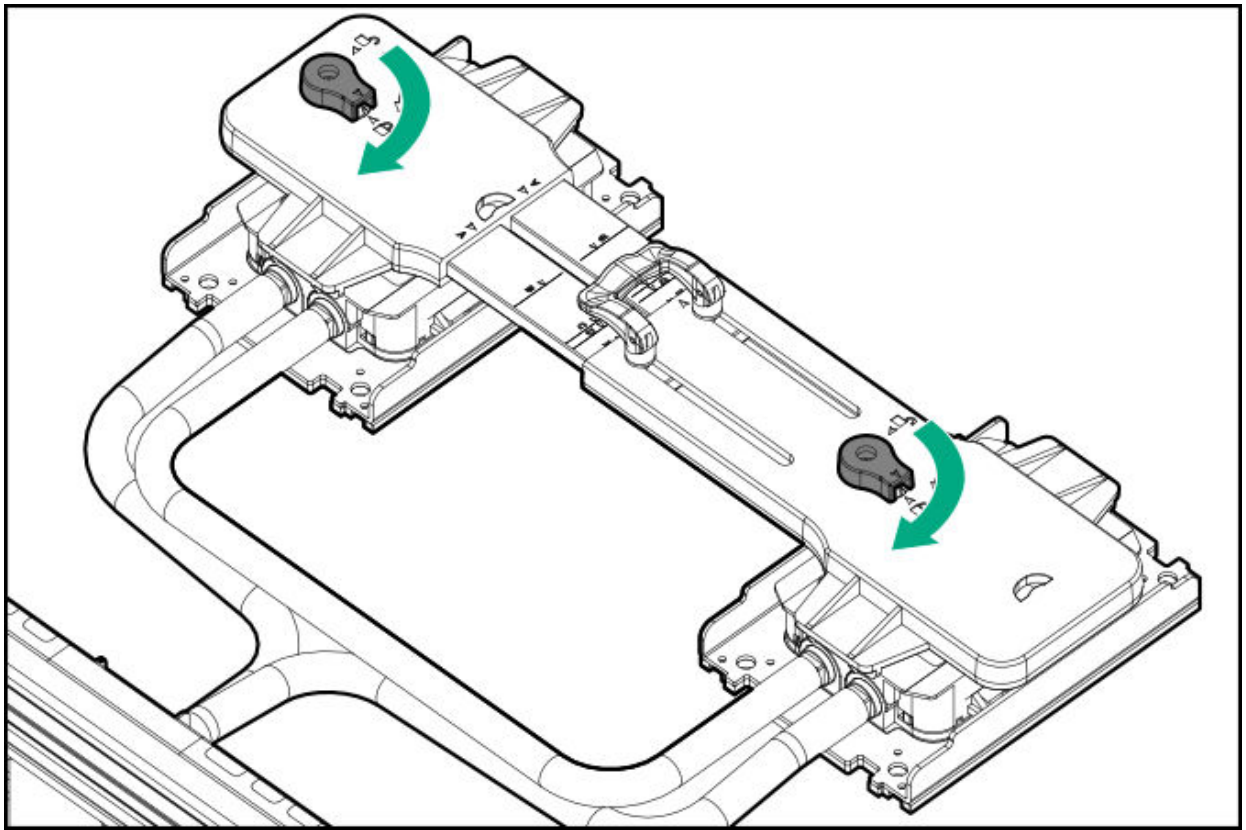

- .0. Loosen the pump-cold plate screws.

- a.



CAUTION

Cold-plate screws must be tightened and loosened in alternating sequence. Do not overtighten the screws as it might damage the system board or the processor socket.

Use a T-30 Torx screwdriver to loosen one pair of diagonally opposite pump-cold plate screws (callouts 1 and 2). Then loosen the other pair of pump-cold plate screws (callouts 3 and 4).

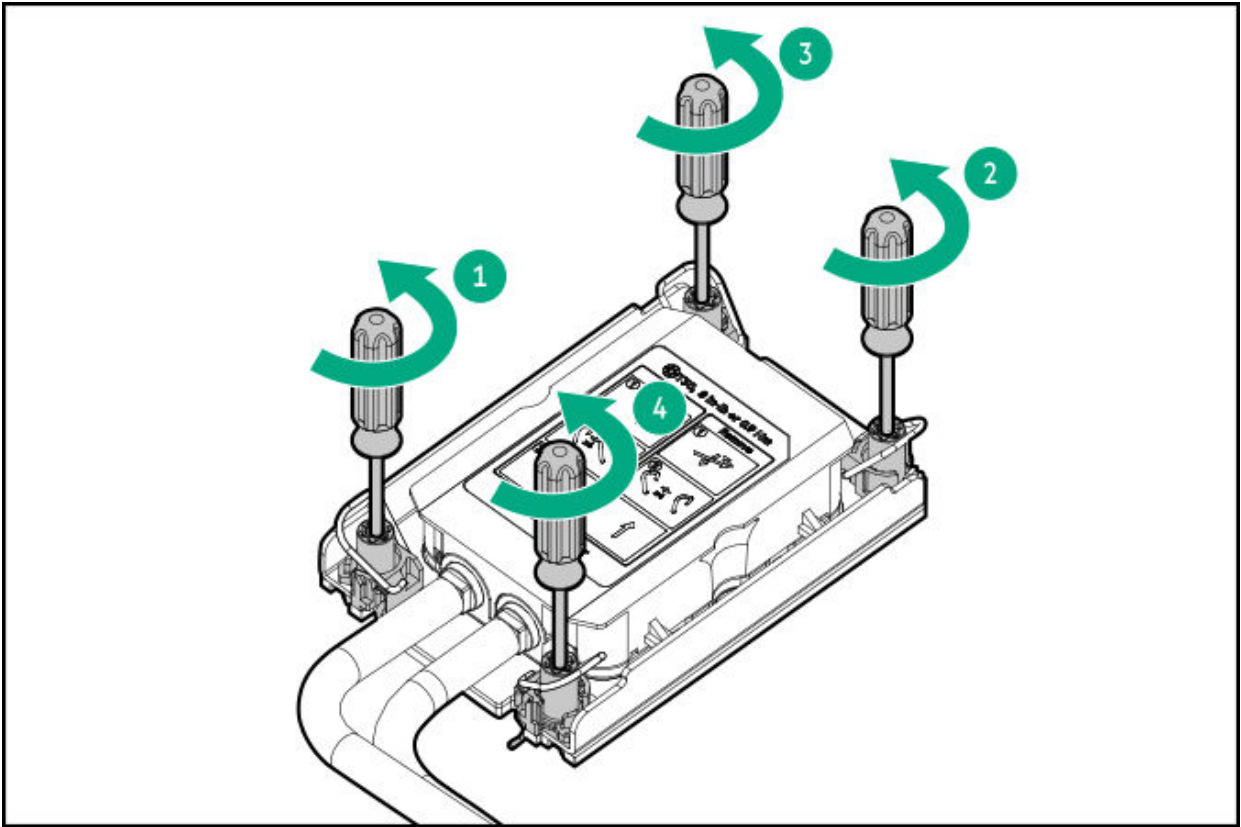

b. Set the anti-tilt wires to the unlocked position.

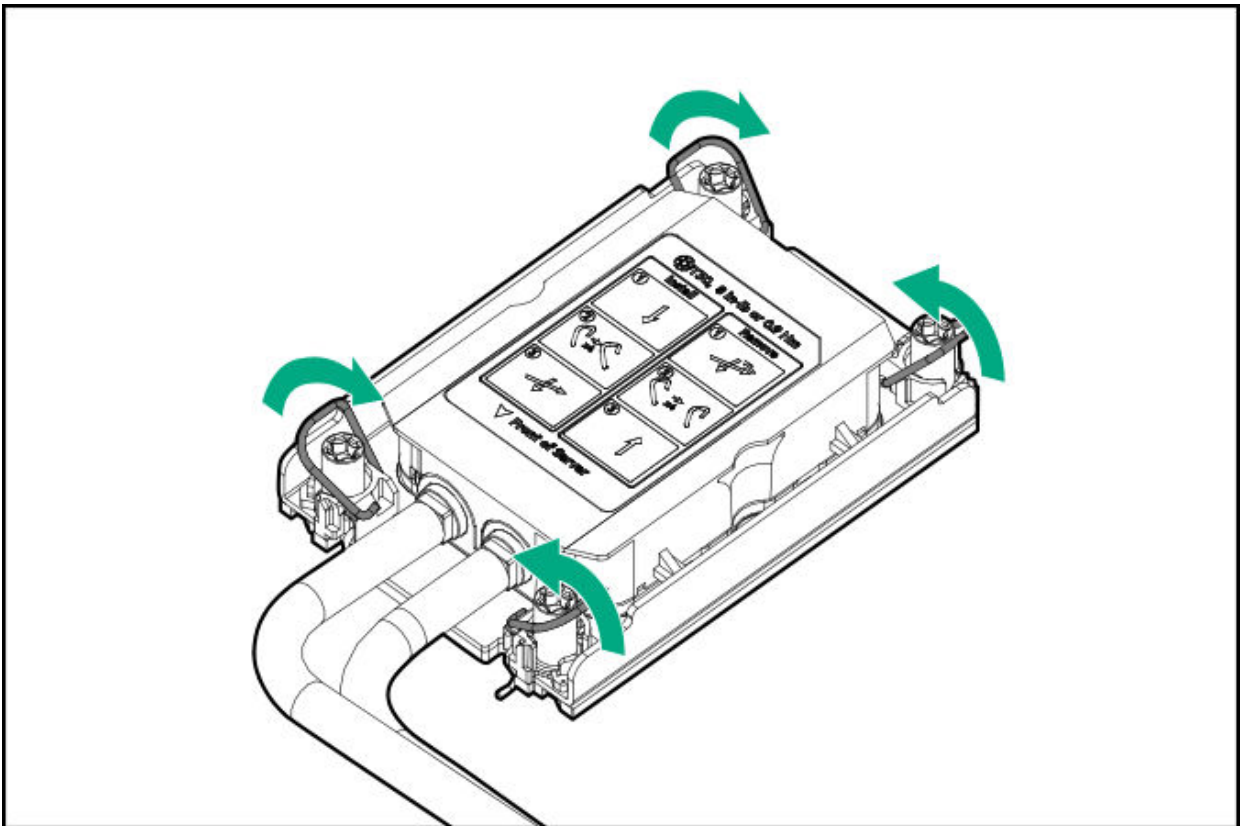

- .1. Disconnect the pump signal cable from the system board.
- .2. Remove the screws from the radiator.

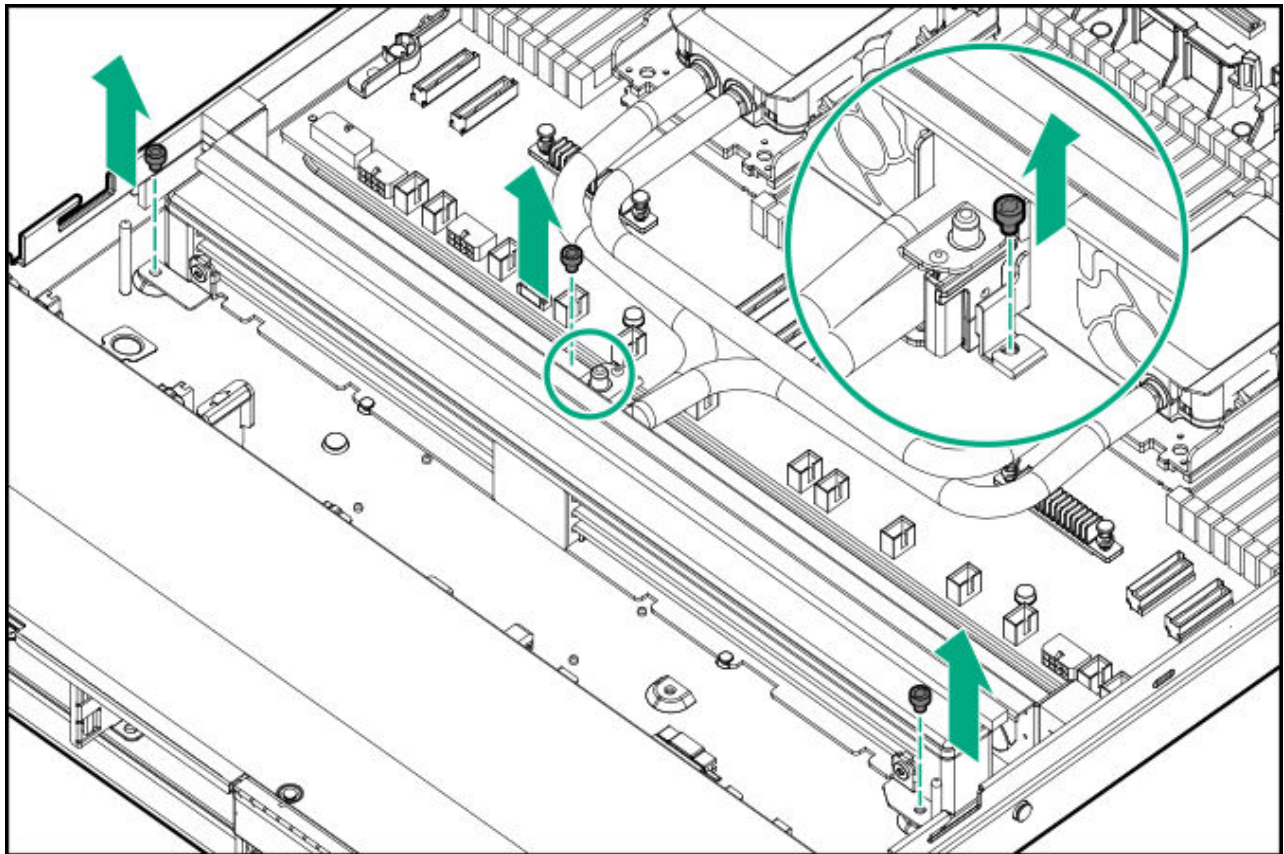

.3.



CAUTION

To avoid damaging the coolant hoses that might result in a coolant leak, do not bend the coolant hoses when installing or removing the liquid cooling module.



CAUTION

Extra caution is required when you are handling the liquid cooling module or processor-carrier assembly during its installation or removal process. **THE PINS ON THE PROCESSOR SOCKET AND ON THE PROCESSOR ARE VERY FRAGILE AND EASILY DAMAGED.**

Remove the liquid cooling module:

- a. Hold the radiator and handle in the middle.
- b. Slide the radiator to disengage it from the spools on the chassis, and lift the handle and radiator straight up.

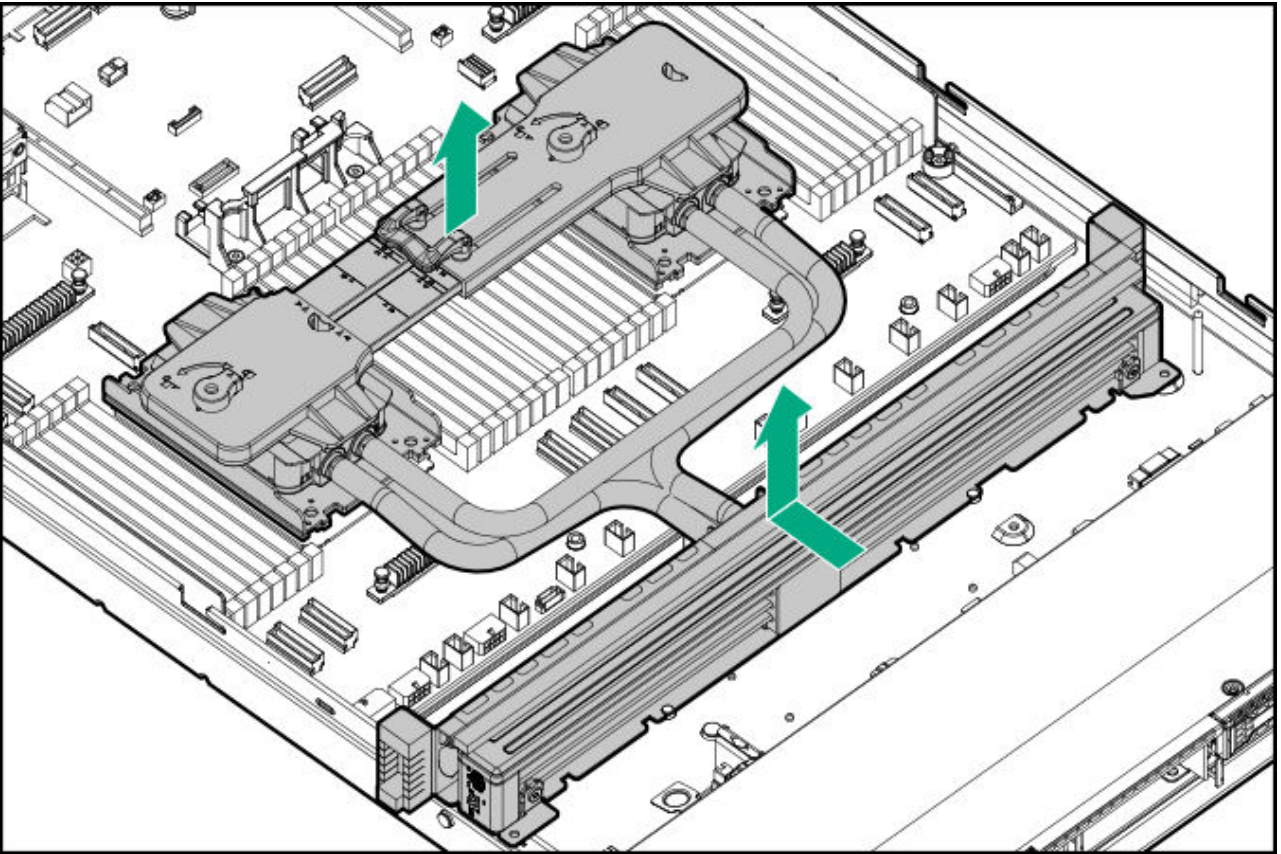

4. Place the liquid cooling module on a flat work surface with its contact side facing up.

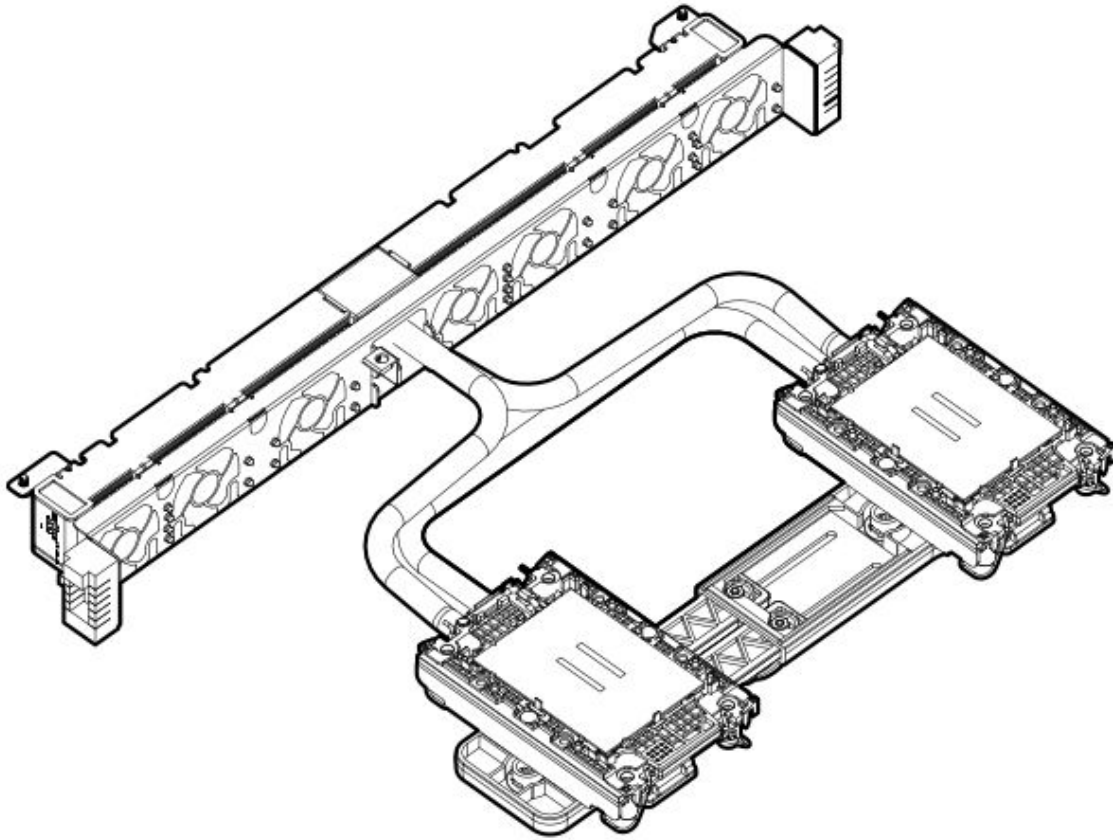

.5. Do not touch the pins on the processor socket and the processor.



CAUTION

THE PINS ON THE PROCESSOR SOCKET AND ON THE PROCESSOR ARE VERY FRAGILE AND EASILY DAMAGED. Any damage to them might require replacing the system board.

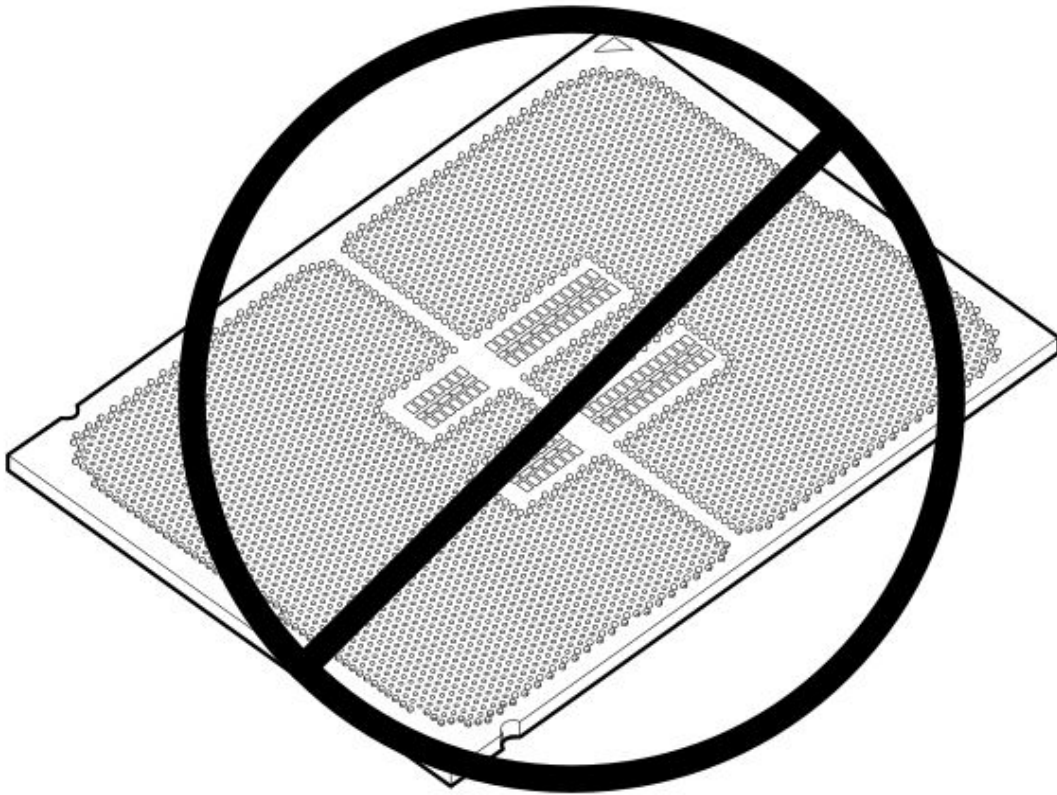
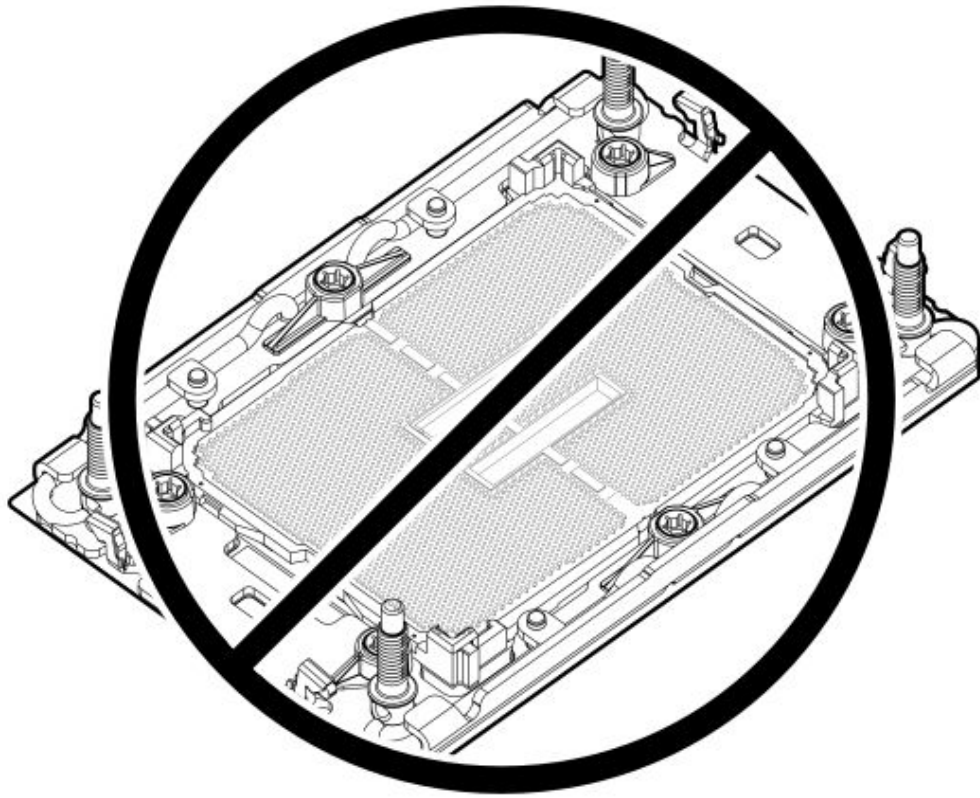

- .6. If you are not immediately installing the replacement processor-heatsink module, install the dust cover on the empty processor socket:



CAUTION

Do not press down on the dust cover. Pressing down on the dust cover might damage the processor socket.

- a. Press and hold the grip tabs on the dust cover.
- b. Carefully lower the dust cover onto the bolster plate guide posts.

Make sure that the corner holes of the dust cover are properly engaged with the guide posts on the bolster plate.

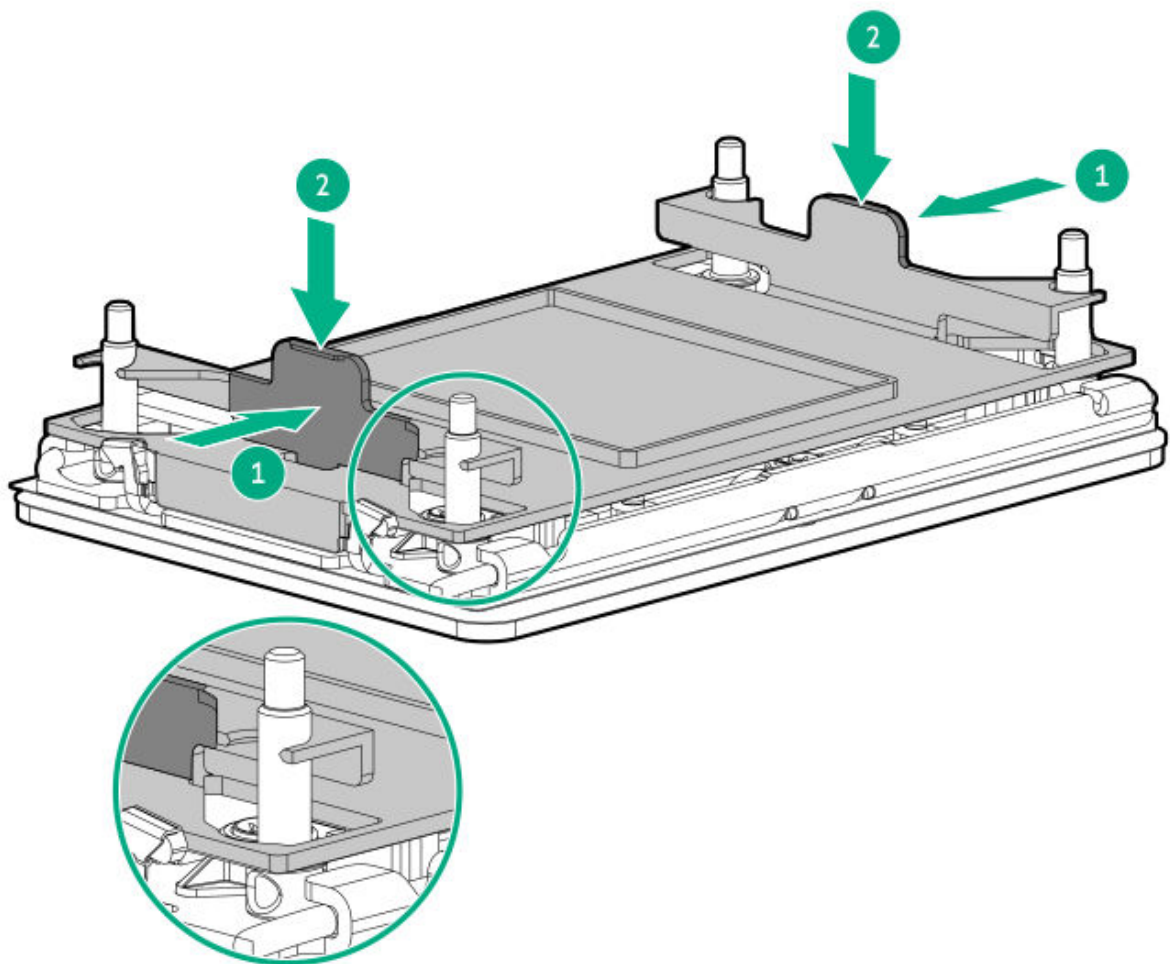

- .7. Remove the processor from the pump-cold plate:

- a. Open the TIM breaker lever.

This action breaks the adhesion between the processor and the pump-cold plate.

b. Hold the processor on its edges, and then remove it from the carrier.

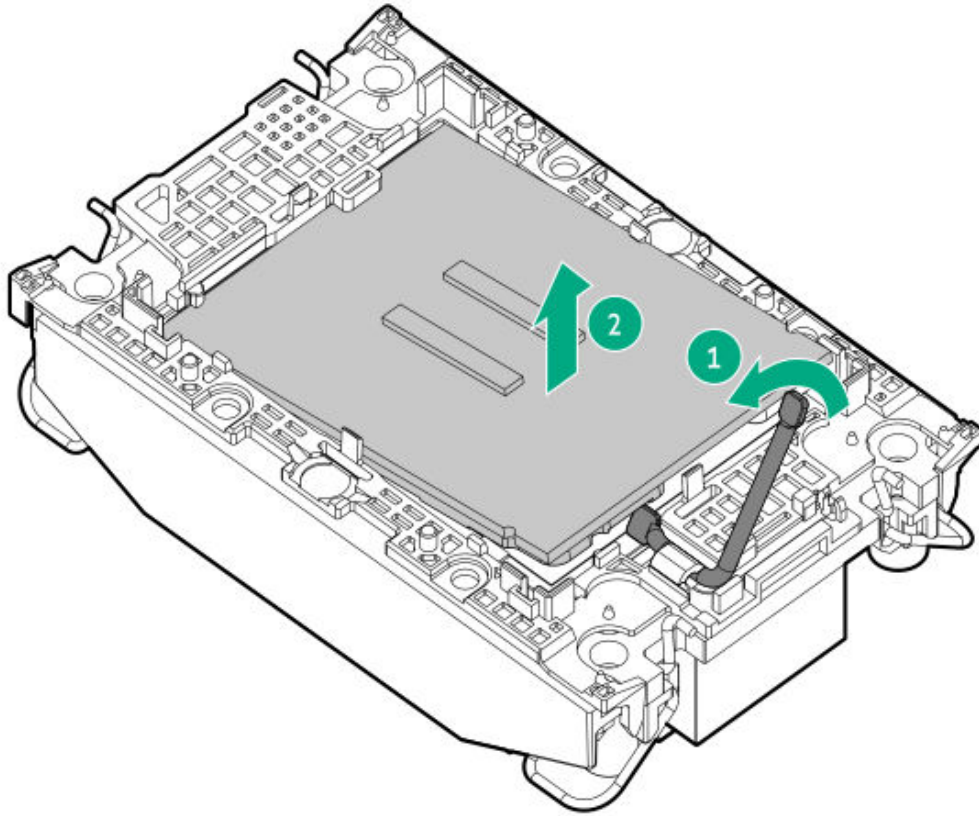

c. Starting from the pin 1 corner and moving in an opposite manner, disengage the processor carrier release tabs from the pump-cold plate.

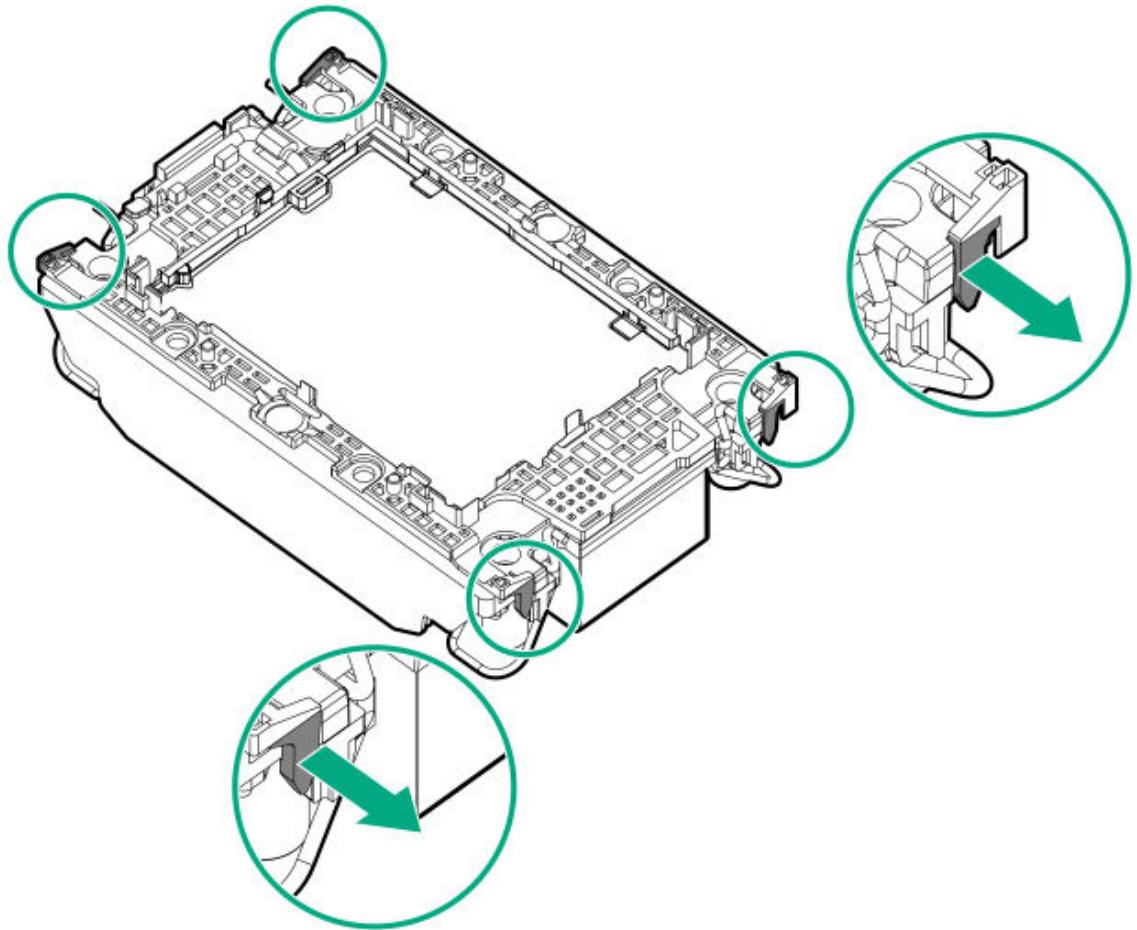

d. Lift the processor carrier away from the pump-cold plate.

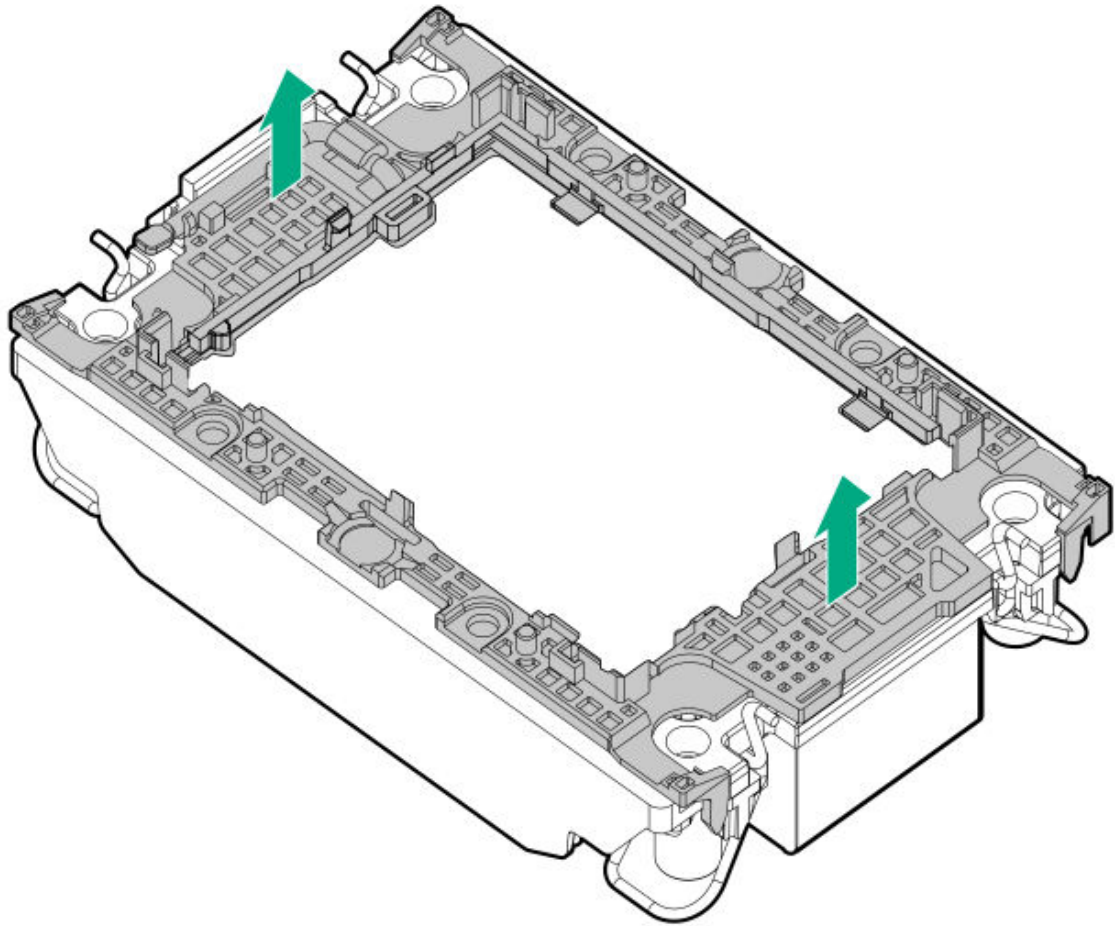

- .8. Using an alcohol wipe to remove the existing thermal grease from the processor and pump-cold plates.
Allow the alcohol to evaporate before continuing.
- .9. Remove the handle from the pump-cold plates.

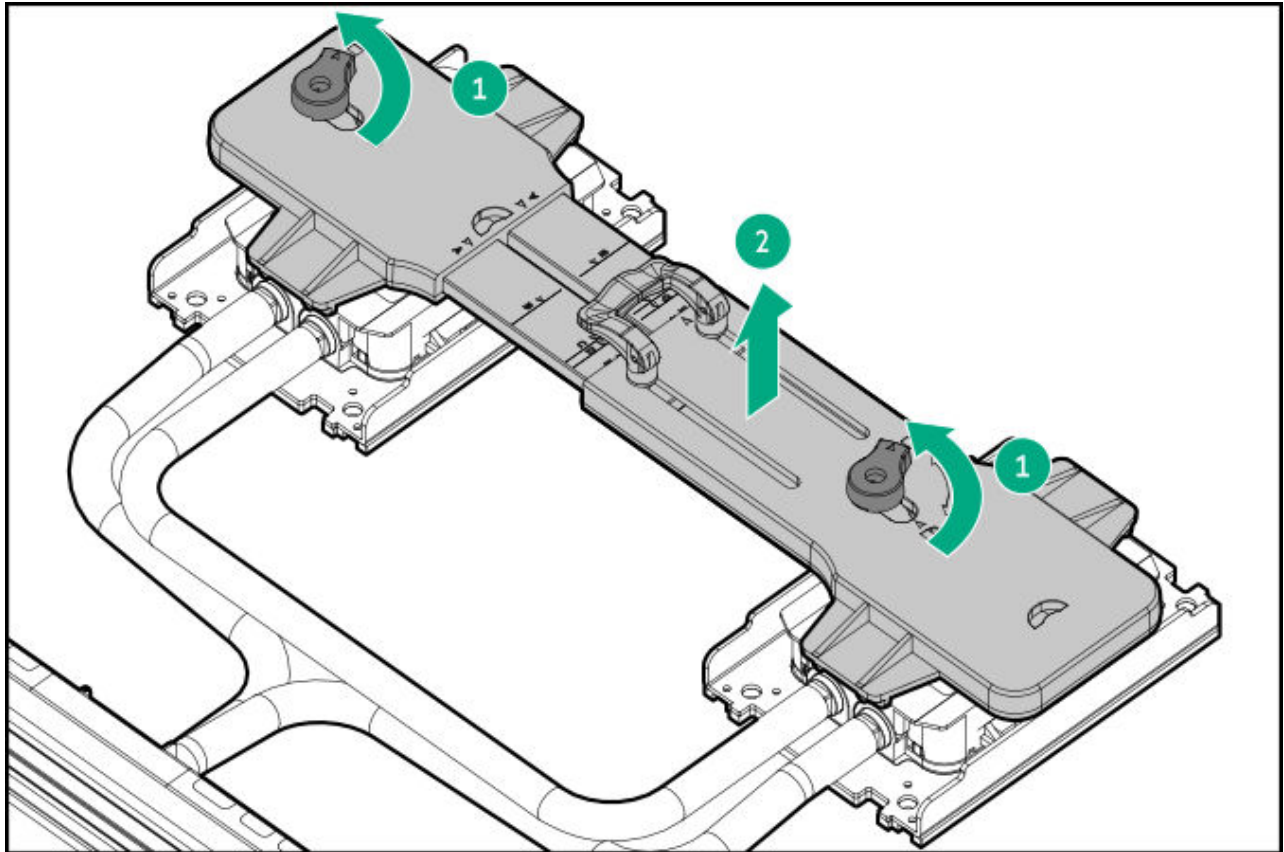

Installing the closed-loop liquid cooling module on the system board

Prerequisites

- Review the following:
 - [Closed-loop liquid cooling \(CLLC\) module components](#)
 - [Heatsink and processor socket components](#)
 - [Processor cautions](#)
 - [Eye and skin protection](#)
- Before you perform this procedure, make sure that you have the following items available:
 - Liquid cooling module handle that ships with the closed-loop liquid cooling module spare part
 - T-30 Torx screwdriver or a bit driver with T-30 Torx bit
 - T-15 Torx screwdriver

About this task



CAUTION

A discharge of static electricity from a finger or other conductor might damage system boards or other static-sensitive devices. To prevent damage, observe antistatic precautions.

Procedure



IMPORTANT

If you are installing or replacing the liquid cooling module in a system using the one-processor configuration, note the following:

- To prevent any interference issues, remove the dust covers from both processor sockets before installing the cold plates.
- Do not touch or remove the thermal interface material on the contact side of the cold plate that does not have a processor-carrier assembly installed.

If installed, remove the dust covers from the processor sockets:

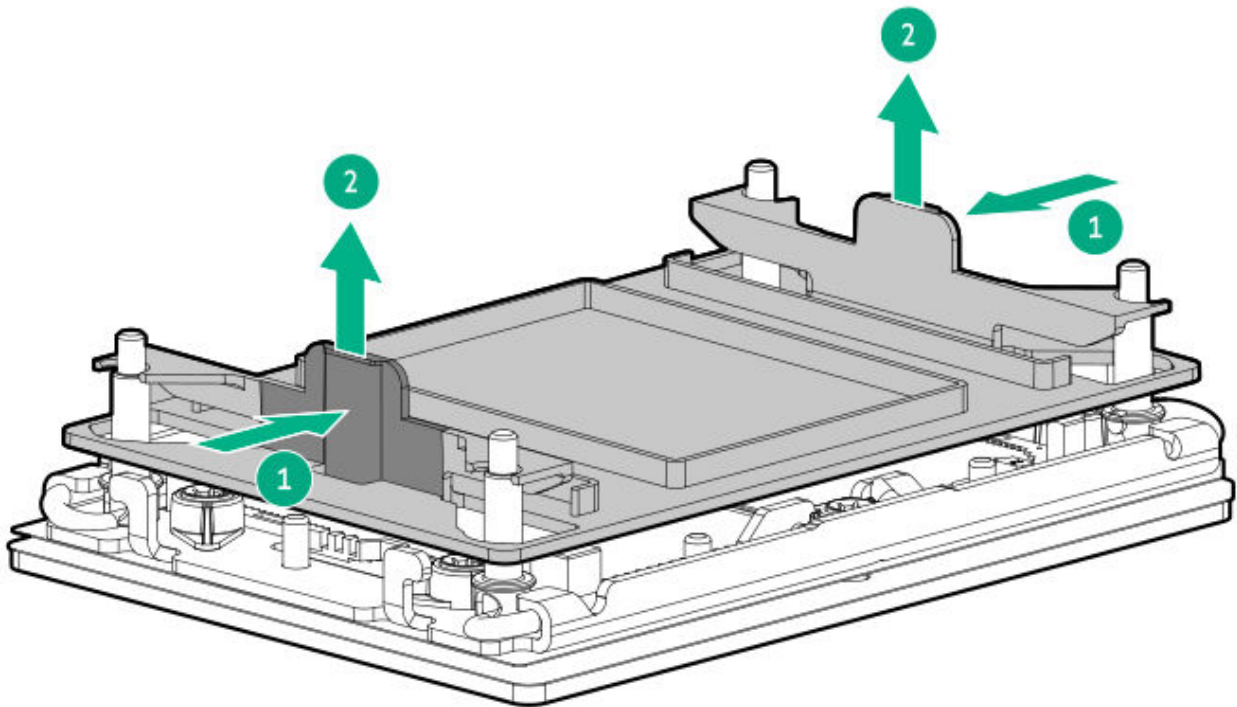

2. Do not touch the pins on the processor socket and the processor.



CAUTION

THE PINS ON THE PROCESSOR SOCKET AND ON THE PROCESSOR ARE VERY FRAGILE AND EASILY DAMAGED. Any damage to them might require replacing the system board.

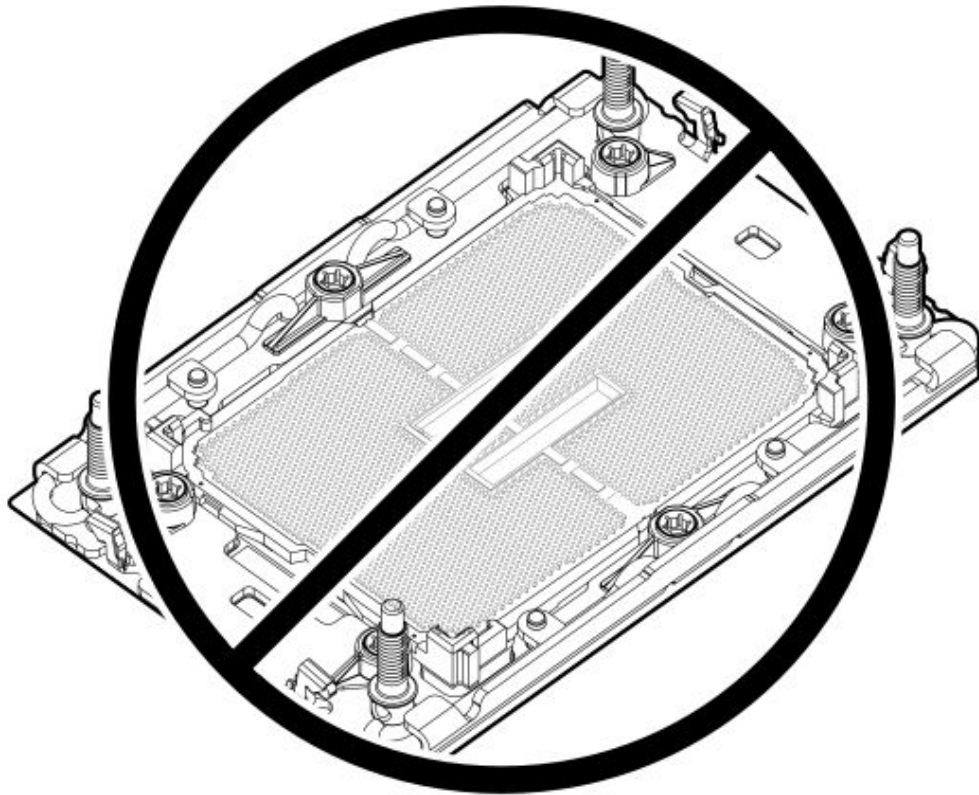

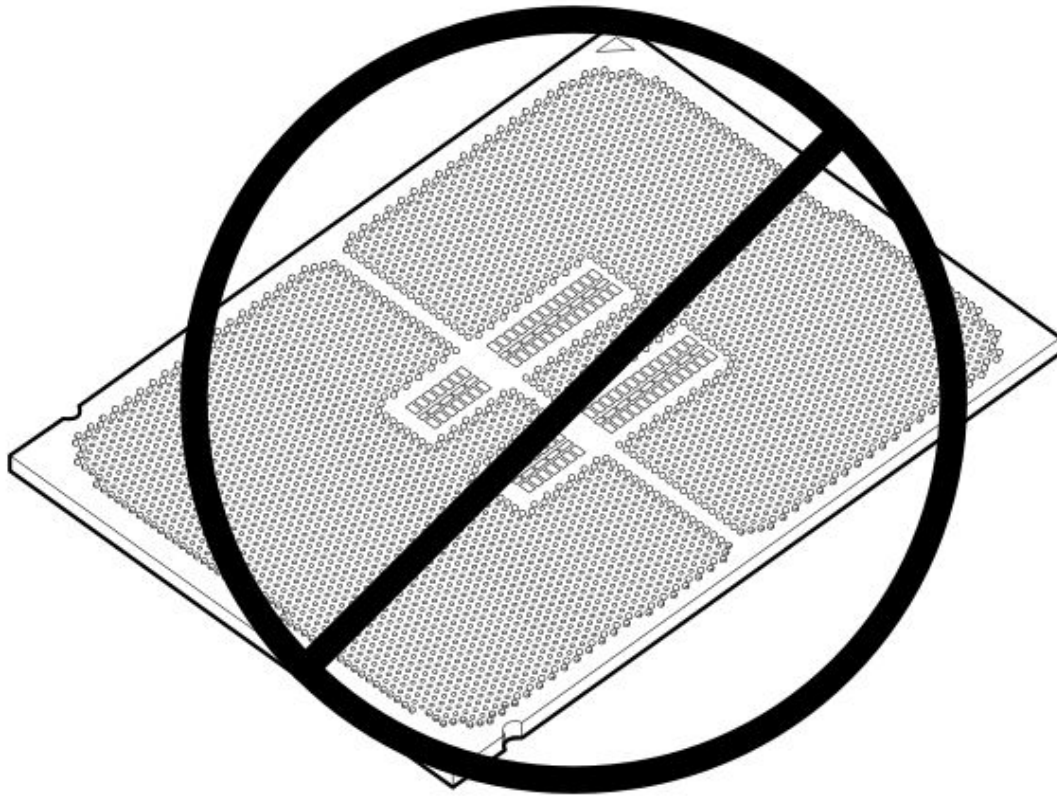

3. Set the liquid cooling module handle to the appropriate length.
 - a. Disengage the locking handle.
 - b. Extend the handle and align the edge to the line marked by the letter E.
 - c. Engage the locking handle.

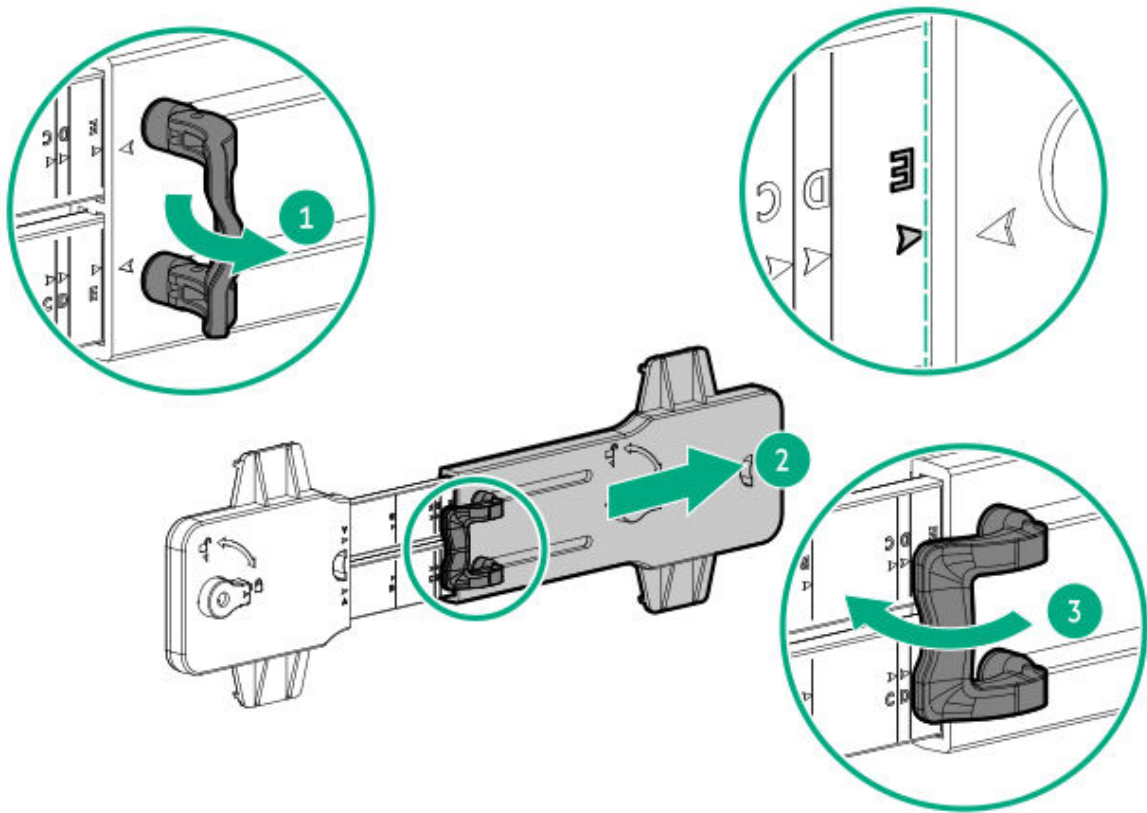

4. Attach the handle to the pump-cold plates:

- a. Rotate the handle knobs anti-clockwise to the unlocked position.

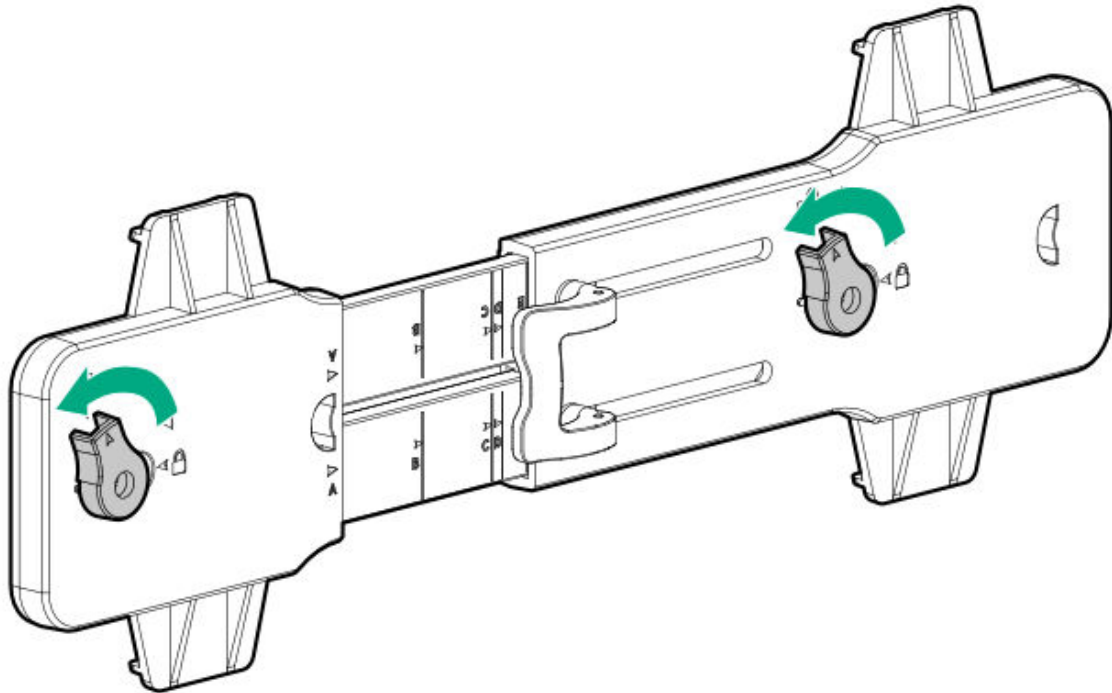

- b. Align the hooks on the handle with the notches on the pump-cold plates, and then attach the handle to the pump-cold plates.

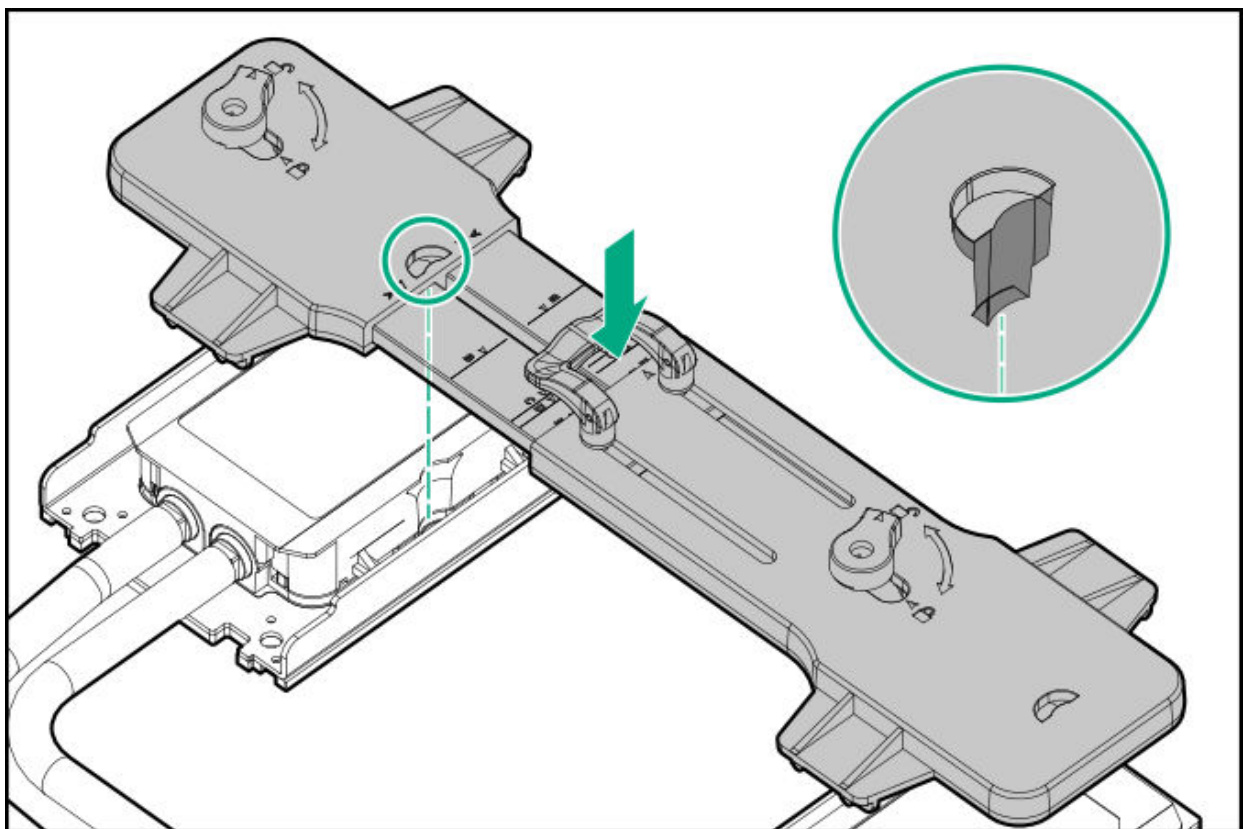

- c. Turn the handle knobs to the locked position.

Gently pull on the handle and verify that pump-cold plates are securely latched to the handle.

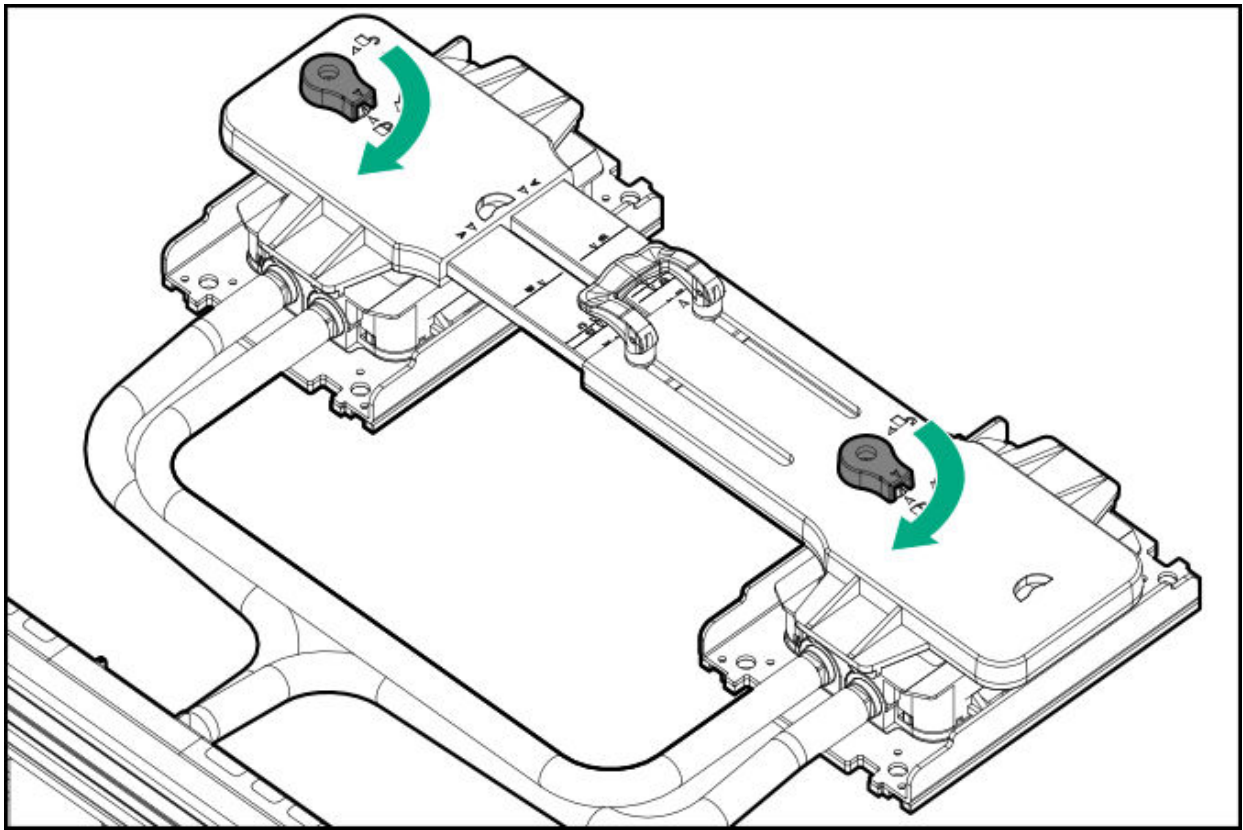

5.



CAUTION

To avoid damaging the coolant hoses that might result in a coolant leak, do not bend the coolant hoses when installing or removing the liquid cooling module.

Place the liquid cooling module on a flat work surface with its contact side facing up.

- a. Hold the liquid cooling module handle and radiator in the middle.
- b. Lift and turn the liquid cooling module over, and place it on a flat and level surface.

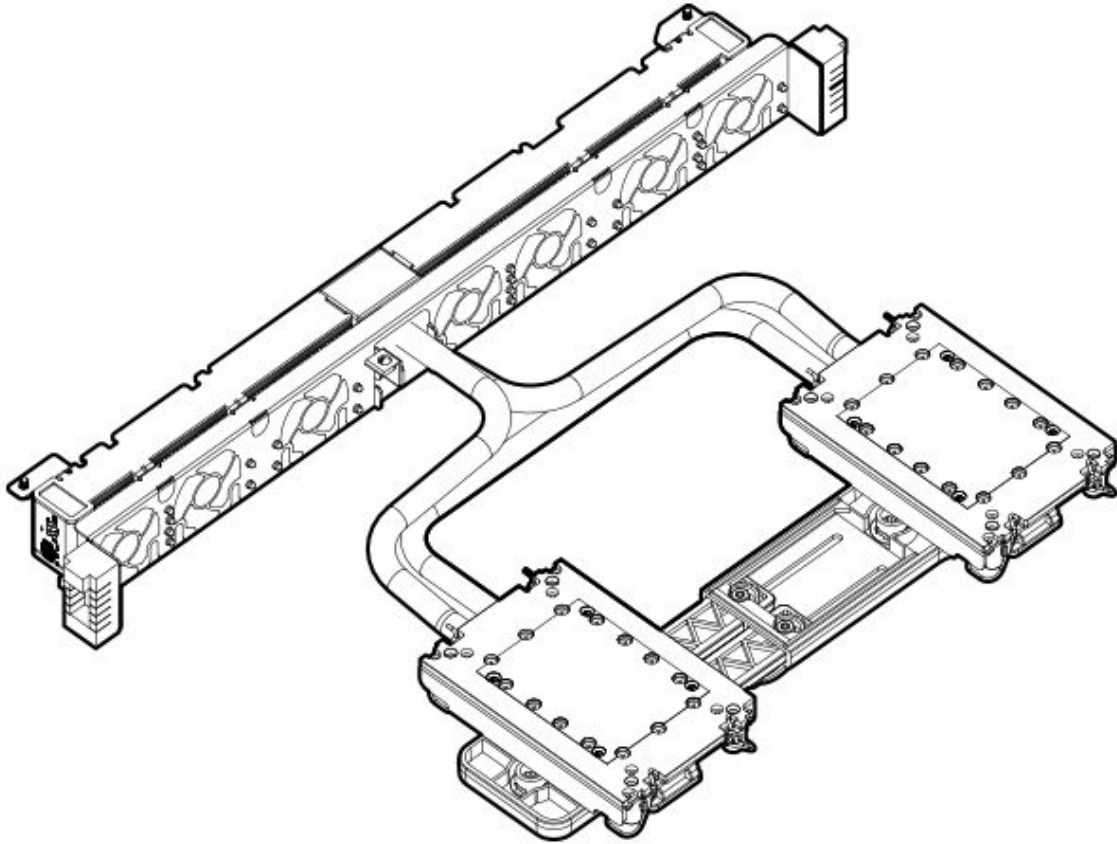

6. Remove the clear protective covers from the new liquid cooling cold plates and pumps.
7. Install the processor carrier on the processor:
 - a. Align the pin 1 indicator on the processor carrier with that on the processor, and then press on the pair of opposite sides on the TIM breaker lever of the processor carrier until it clicks into place.

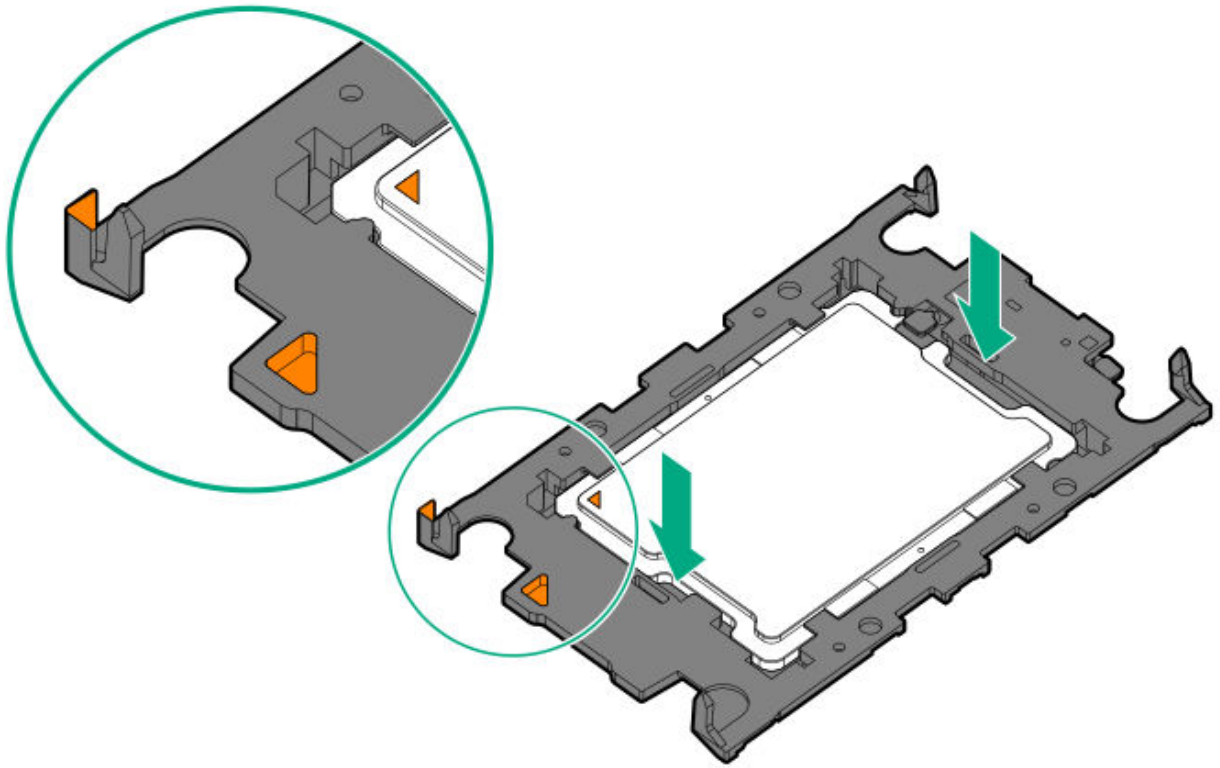

b. Verify that the processor is properly latched on the processor carrier.

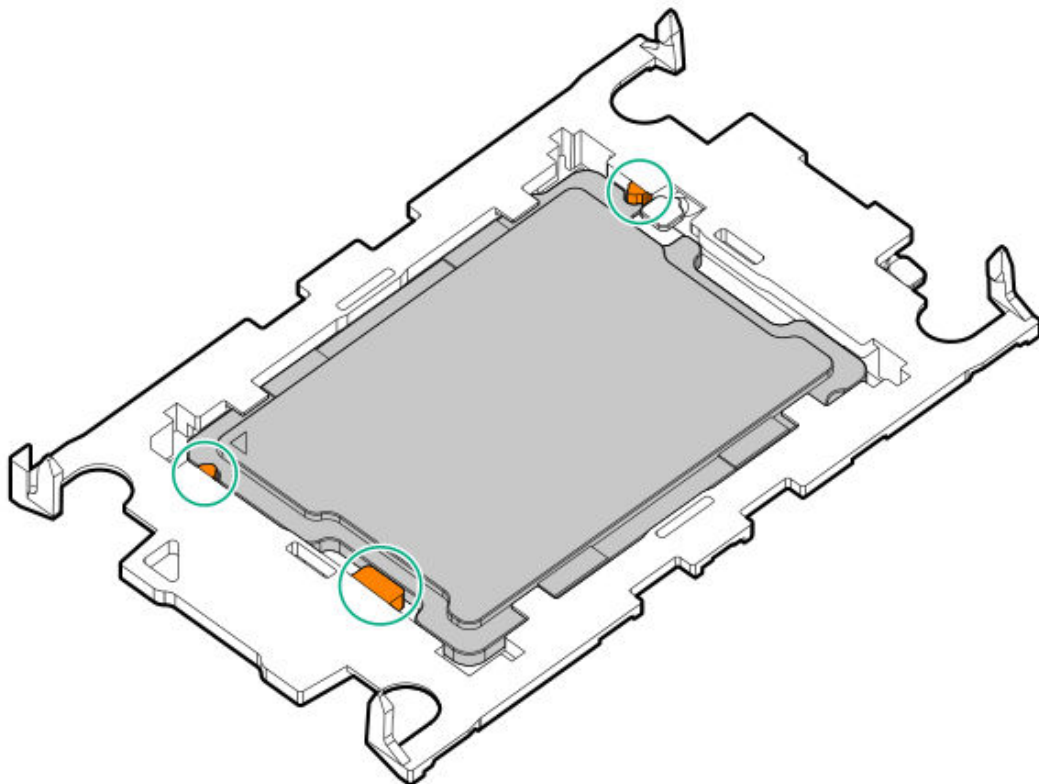

If not, press the other pair of opposite sides of the processor carrier until it clicks into place.

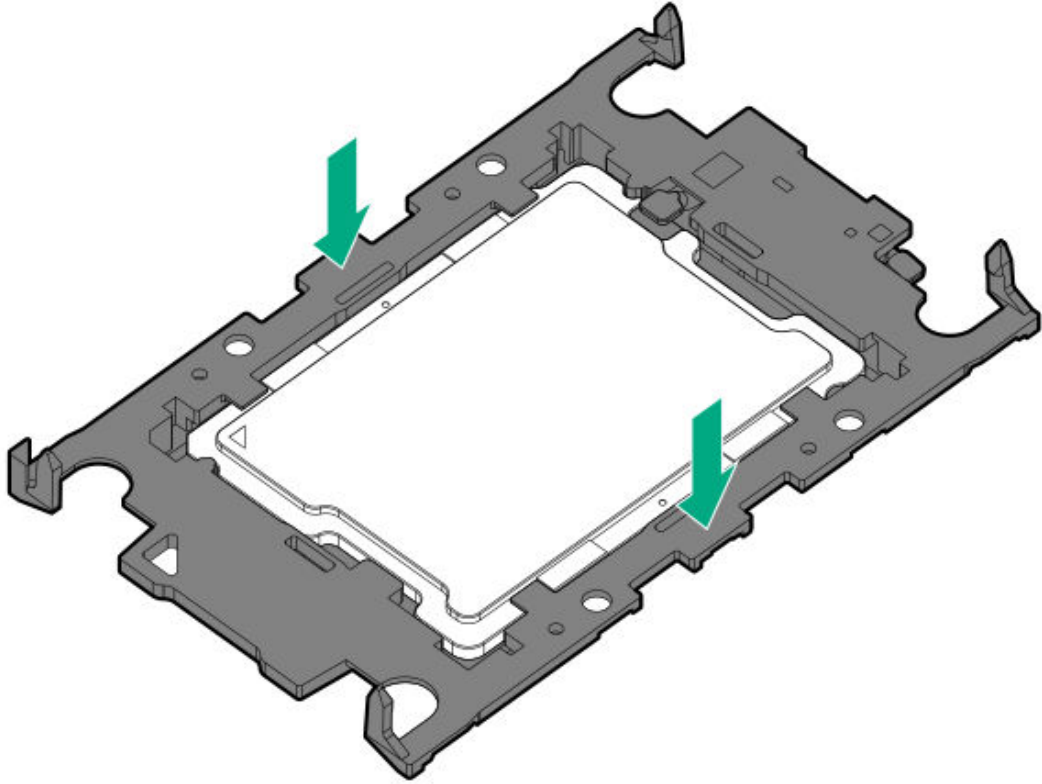

8. Attach the processor carriers to the pump-cold plates:
 - a. Align the pin 1 indicator on the processor carrier with that of the pump-cold plate.

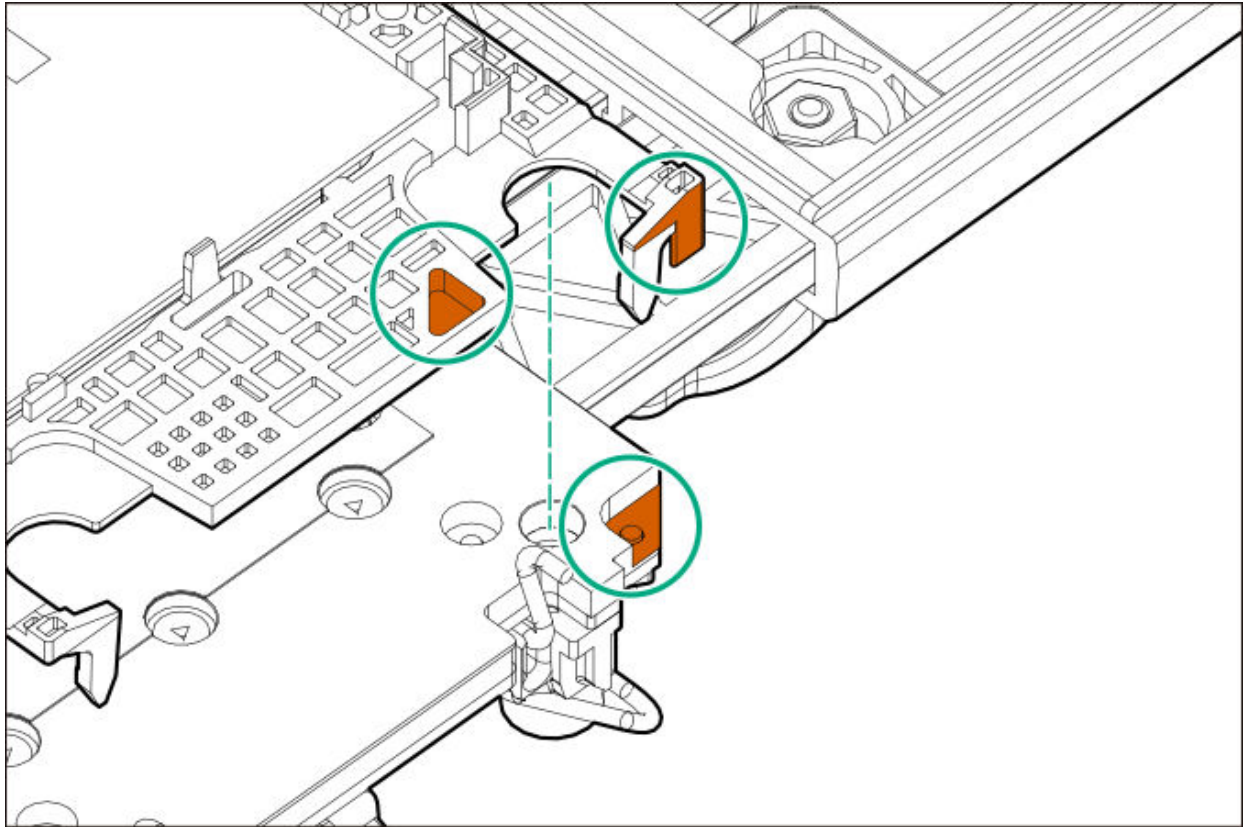

- b. Lower the processor carrier on the pump-cold plate until the carrier tabs snap into place.

There will be an audible click to indicate that the processor carrier is properly latched on the pump-cold plate.

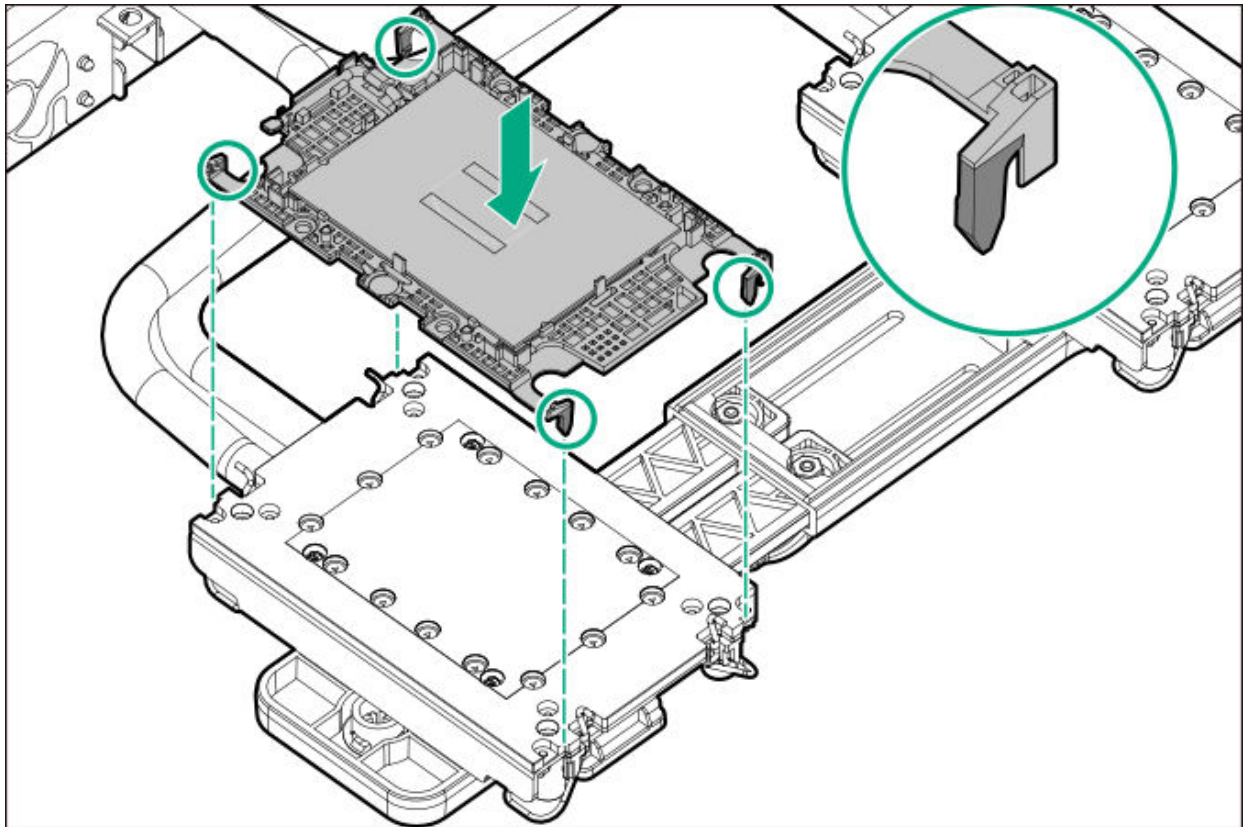

9. Perform the following verification steps:

- a. Verify that the tabs on the processor carrier are securely latched on the cold plate.

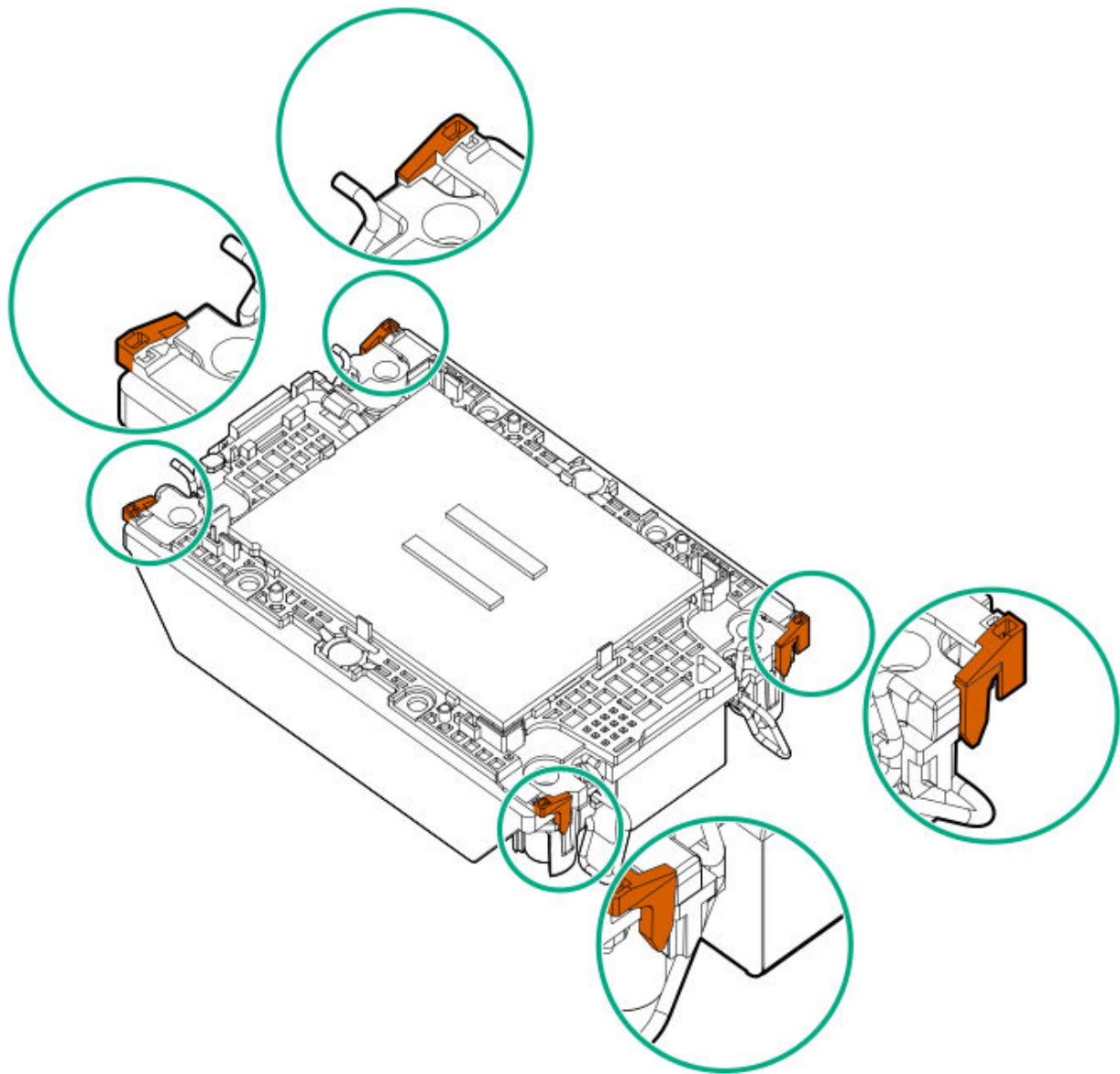

b. Verify that the pin 1 indicators on the processor and processor carrier are aligned.

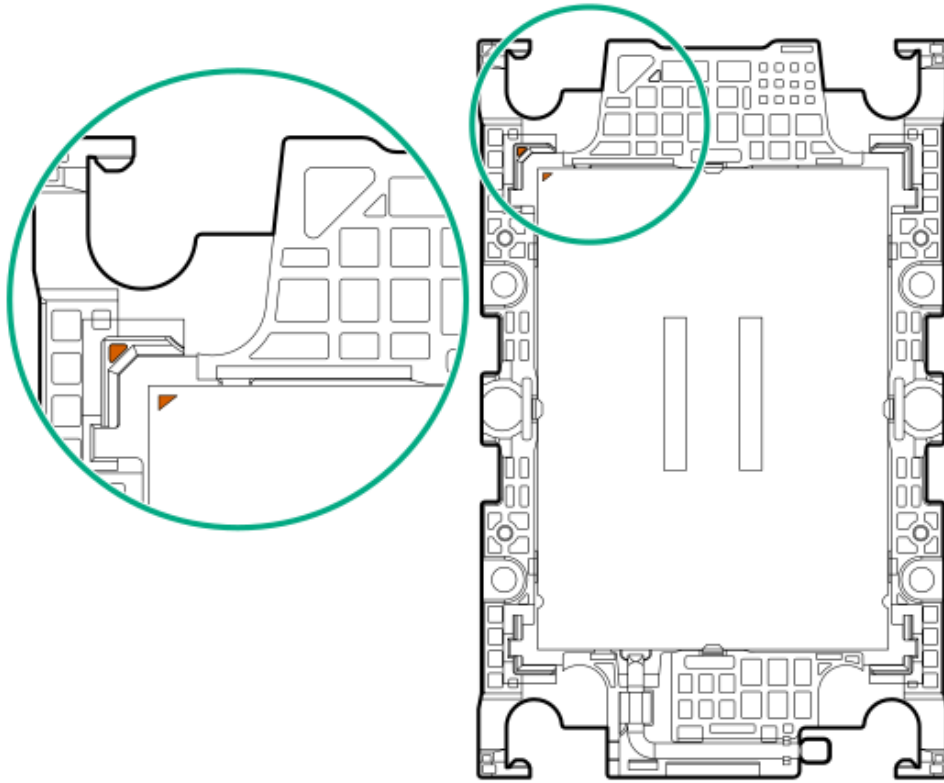

c. Verify that the processor is properly secured by the carrier snaps.

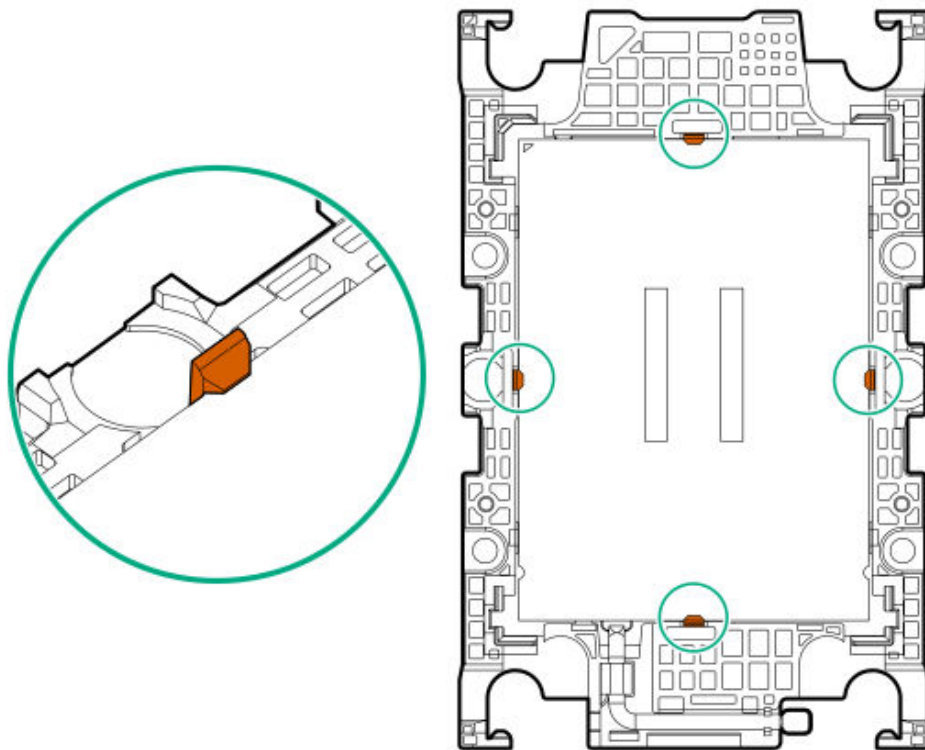

.0. If you want to install a second processor, repeat the previous two steps.

.1.



CAUTION

To avoid damaging the coolant hoses that might result in a coolant leak, do not bend the coolant hoses when installing or removing the liquid cooling module.

Hold the liquid cooling module handle and radiator in the middle.

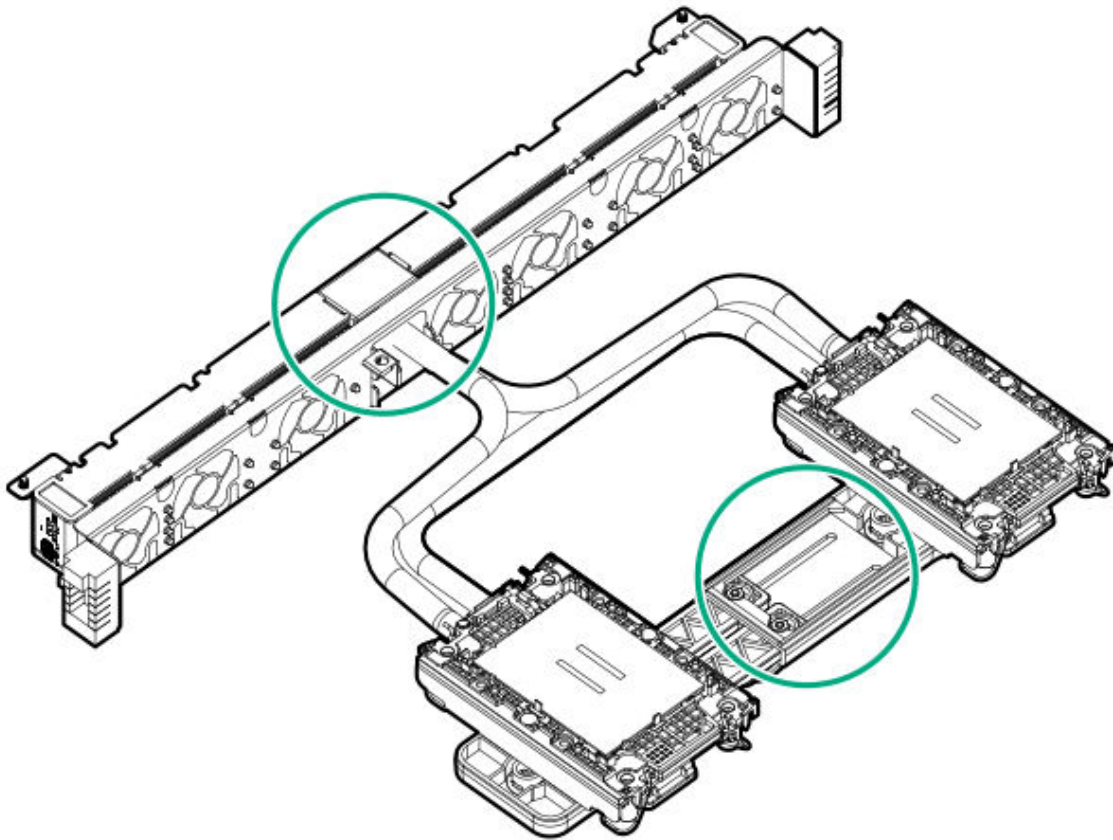

.2.



CAUTION

Extra caution is required when you are handling the liquid cooling module or processor-carrier assembly during its installation or removal process. **THE PINS ON THE PROCESSOR SOCKET AND ON THE PROCESSOR ARE VERY FRAGILE AND EASILY DAMAGED.**



CAUTION

To avoid damaging the coolant hoses that might result in a coolant leak, do not bend the coolant hoses when installing or removing the liquid cooling module.

Place the liquid cooling module on the system board, and slide the radiator to engage with the spools on the chassis.

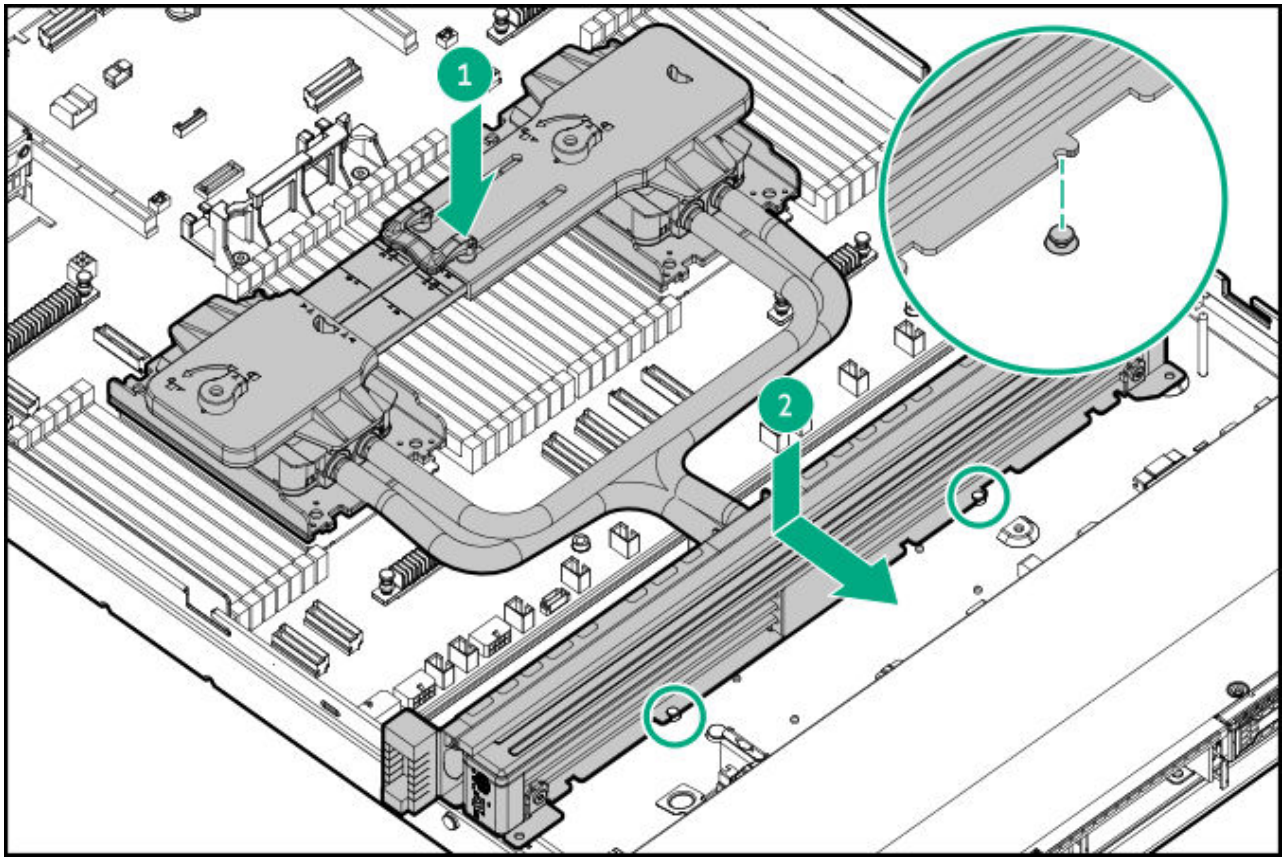

3. Install the liquid cooling cold plates and pumps:

- a. When using a torque screwdriver to tighten the pump-cold plate screws, set 0.9 N-m (8 in-lb) of torque.
- b. Note the **Front of server** text on the pump-cold plate label to correctly orient the pump-cold plate over the bolster plate.
- c. Carefully lower the pump-cold plate onto the bolster plate guide posts.

The posts are keyed so that the module can only be installed one way. Make sure that the module is properly seated on the bolster plate before securing the screws.

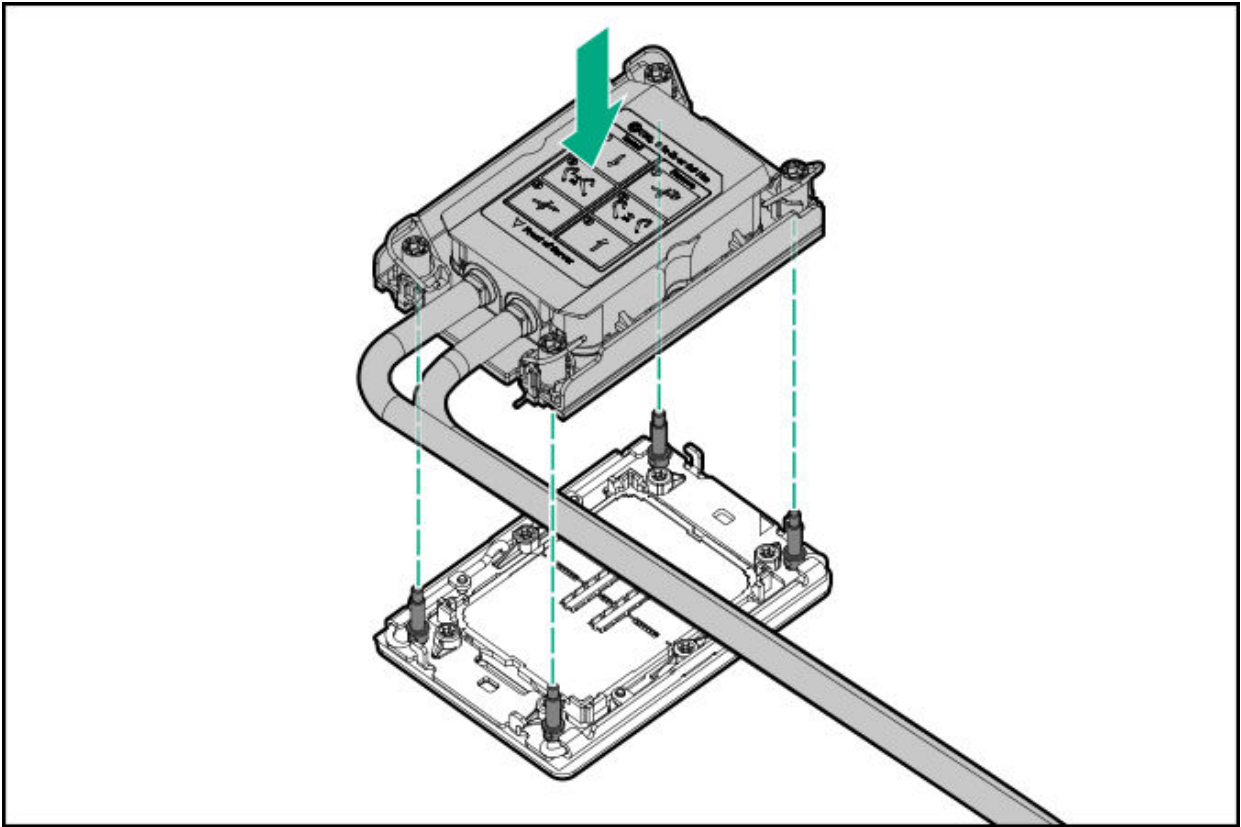

d. Set the anti-tilt wires to the locked position.



e. Tighten the pump-cold plate screws.

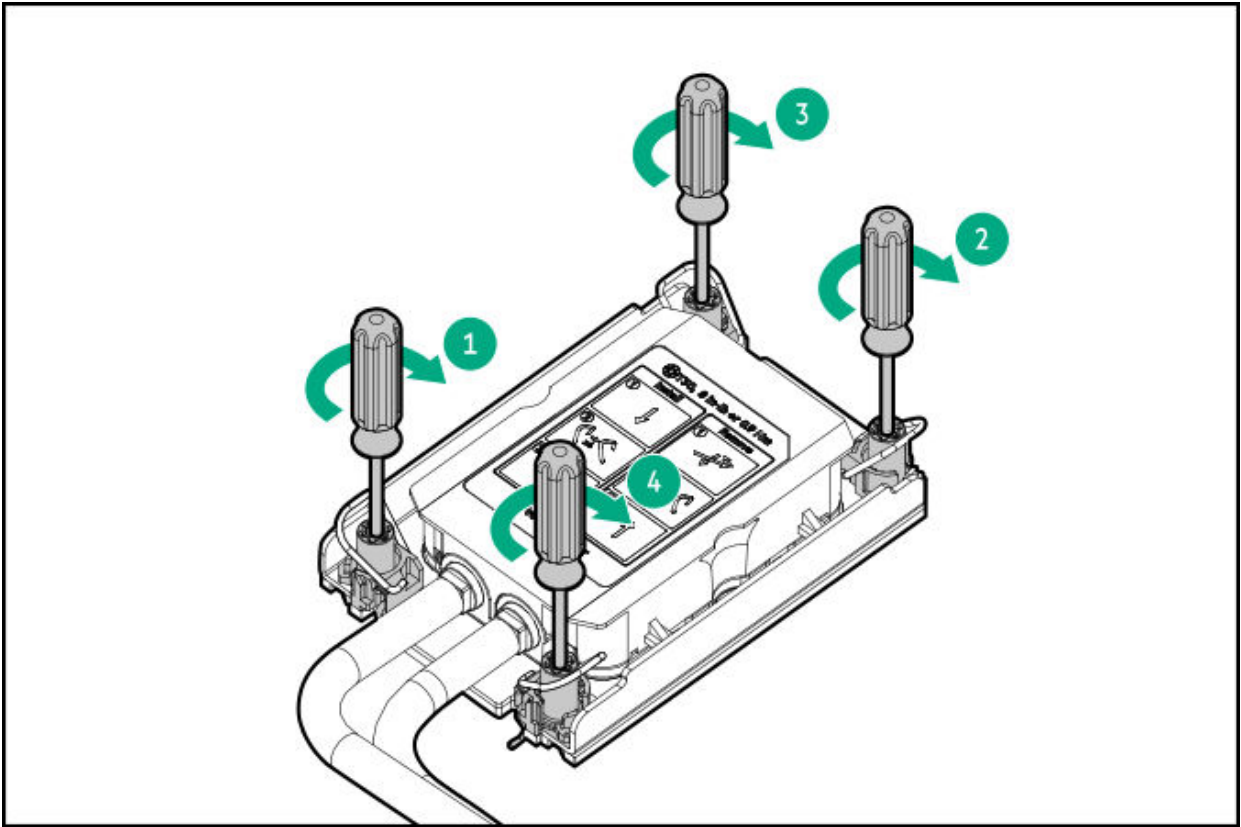

4. Remove the handle from the pump-cold plates.

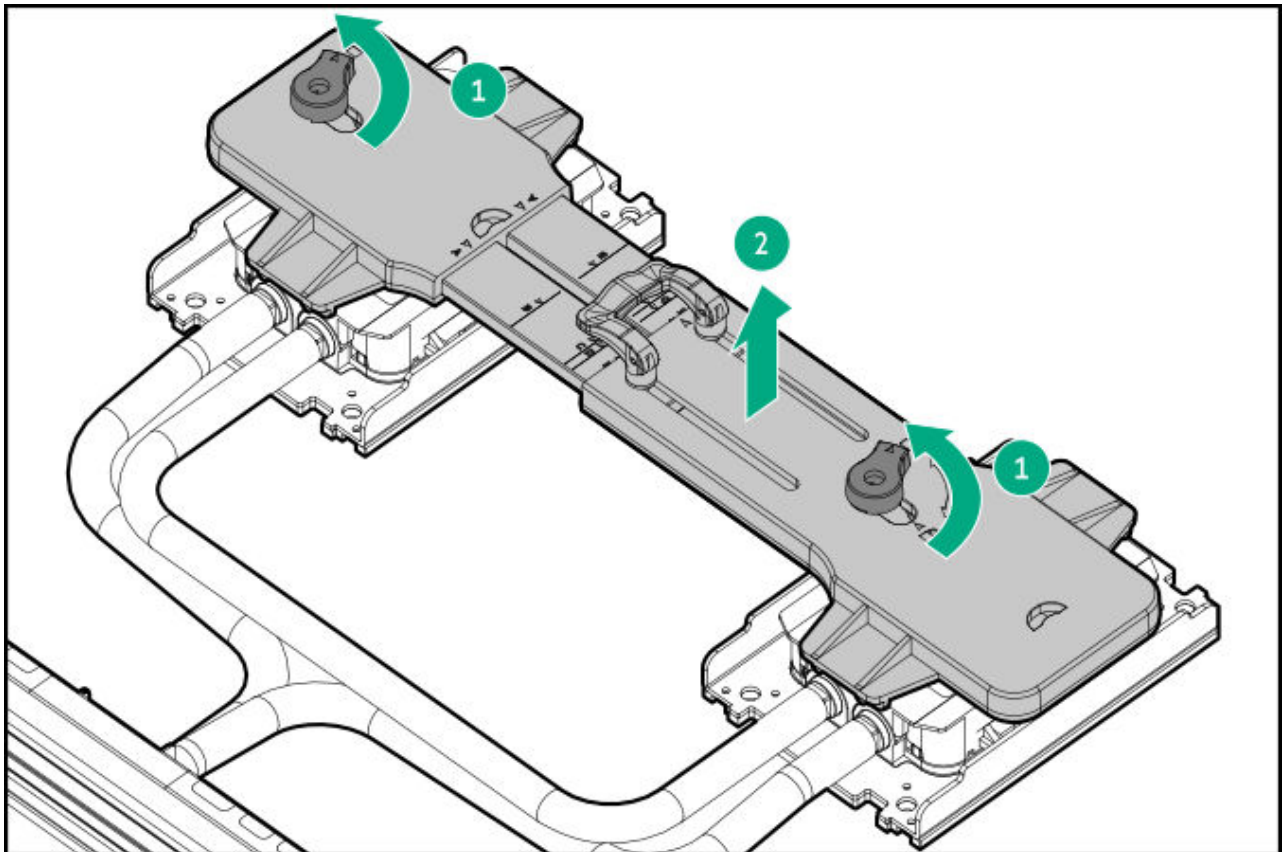

.5. Install the radiator screws on the chassis.

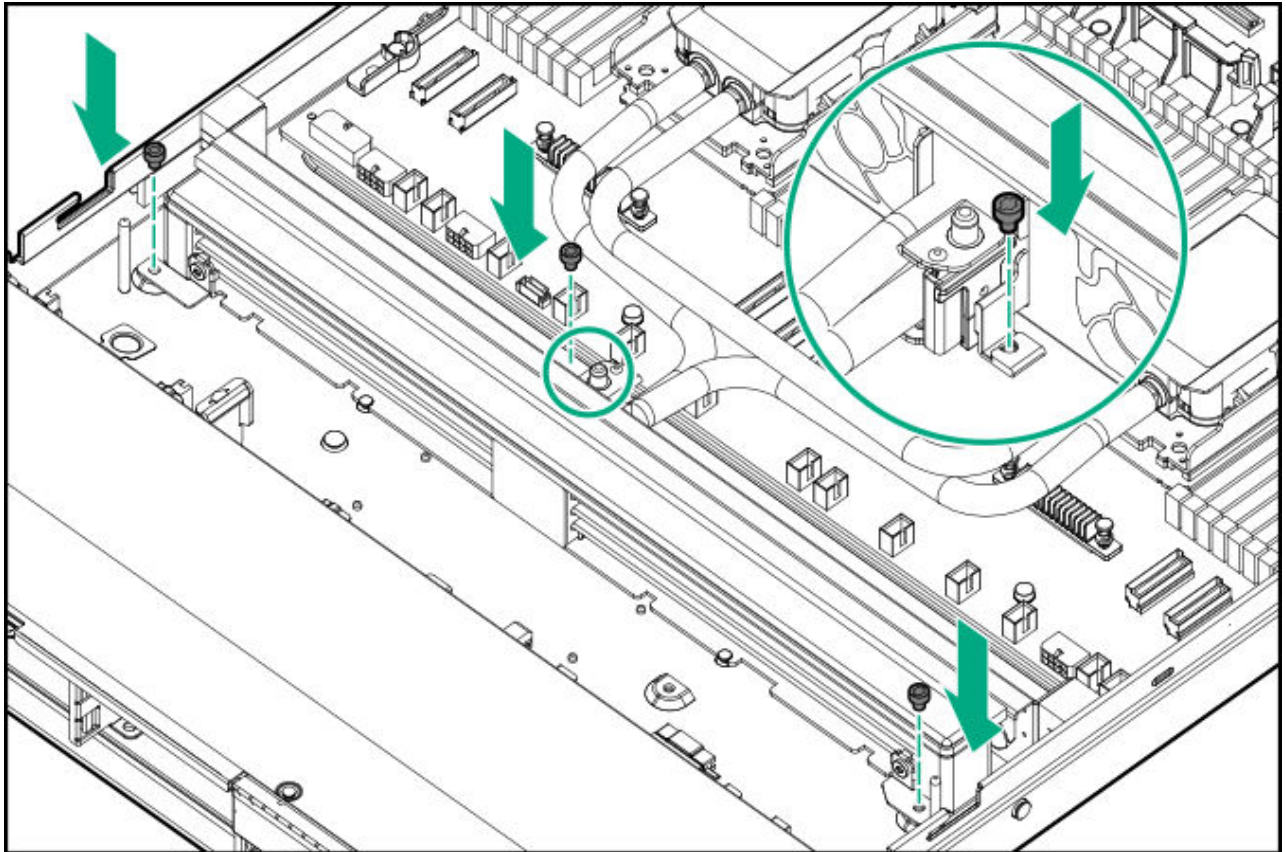

.6. Connect the pump signal cable to the system board.

.7. Install the access panel guide pin.

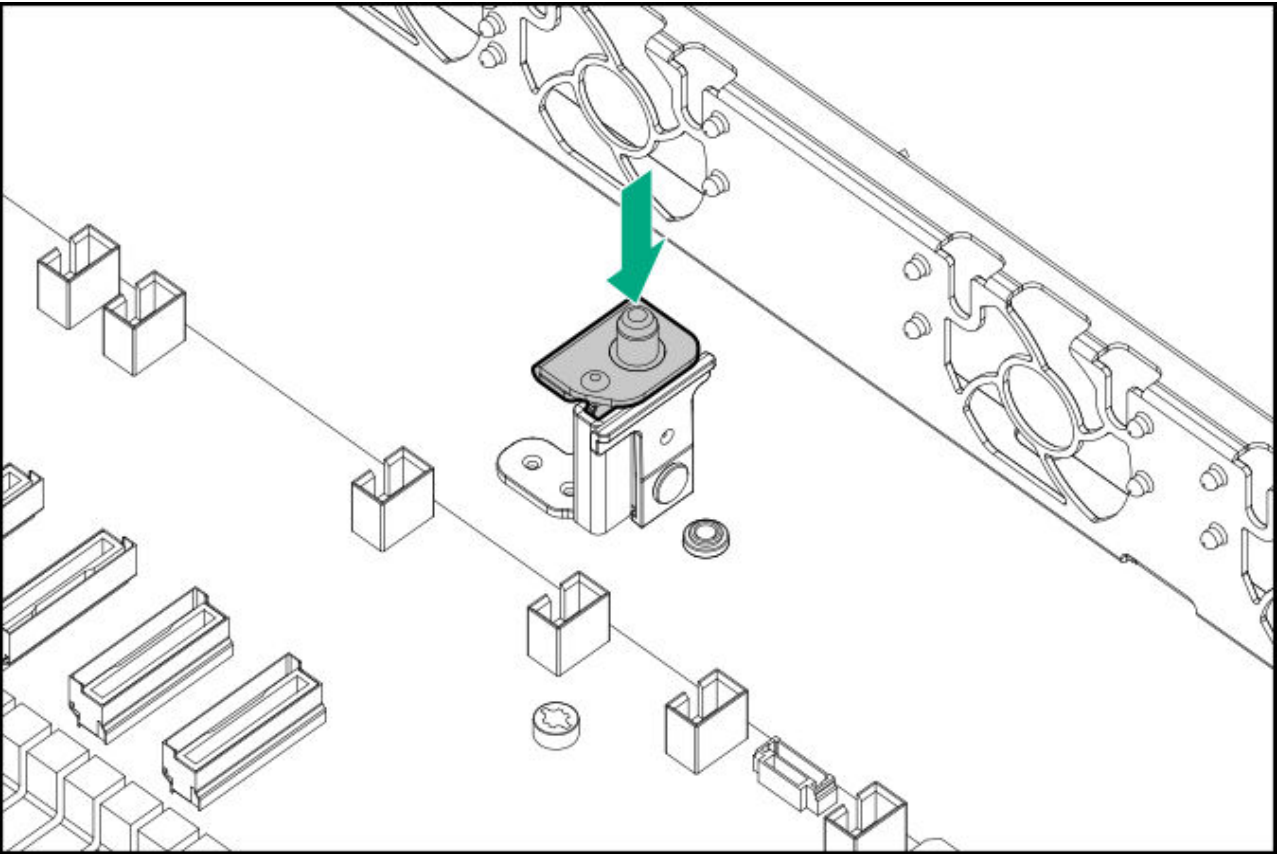

.8. Install all fans.

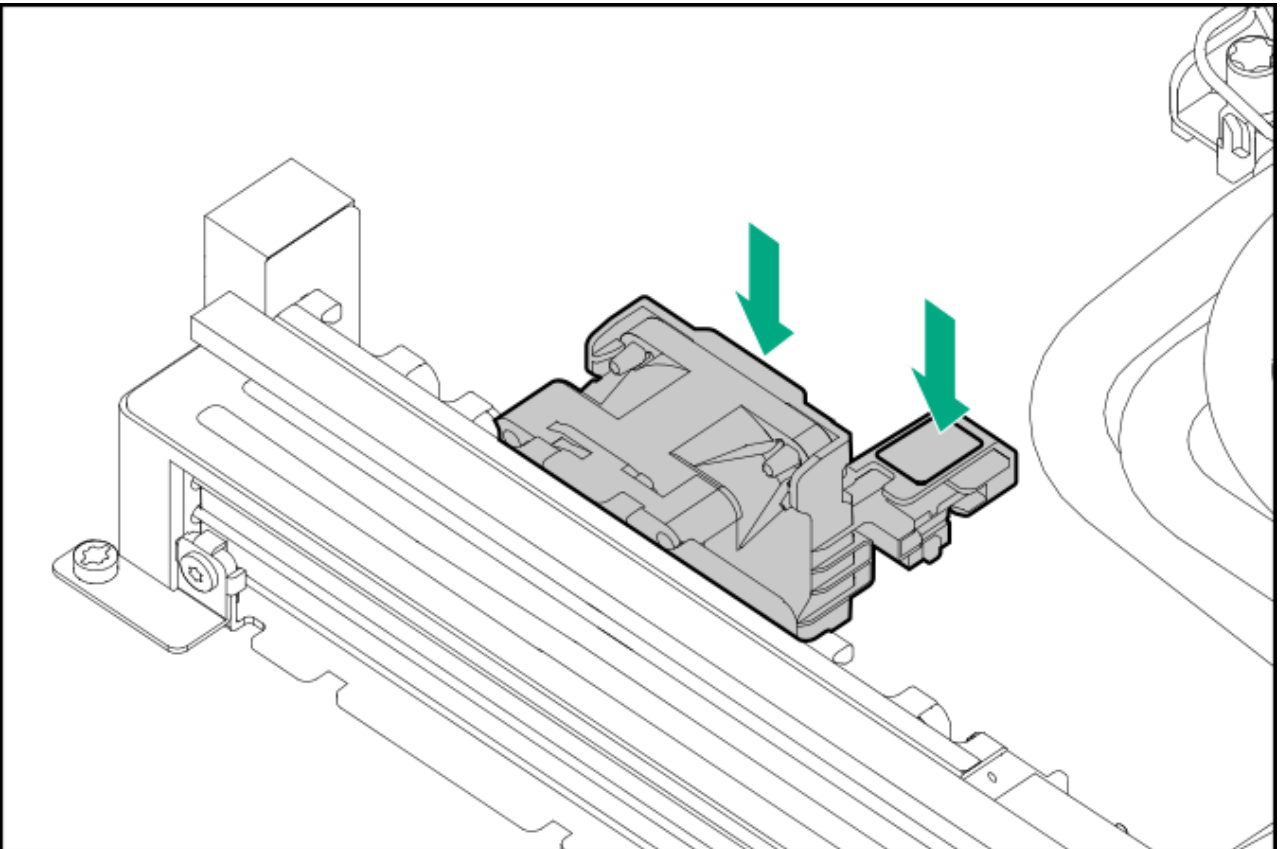

- .9. Install the access panel.
- !0. If the server was removed from an enclosure or a rack, reinstall it now.
- !1. Connect all peripheral cables to the server.
- !2. Connect each power cord to the server.
- !3. Connect each power cord to the power source.
- !4. Power up the server.

Results

The replacement procedure is complete.

Disconnecting the direct liquid cooling kit

Prerequisites

Before you perform this procedure, make sure that you have a small hand towel or container to catch any coolant from the DLC (Direct Liquid Cooling) system.

About this task

For more information on preparing the DLC manifold for DLC module replacement, see the HPE Cray XD/ProLiant Direct Liquid Cooling System Site Preparation, User and Maintenance Guide at <https://www.hpe.com/info/xdDLCguide>.

Procedure

1. Locate the DLC module hoses at the rear of the server.



NOTE

This image shows possible hose locations. Hoses will only come from either the secondary riser cage or the rear NS204i-u bracket, not both.

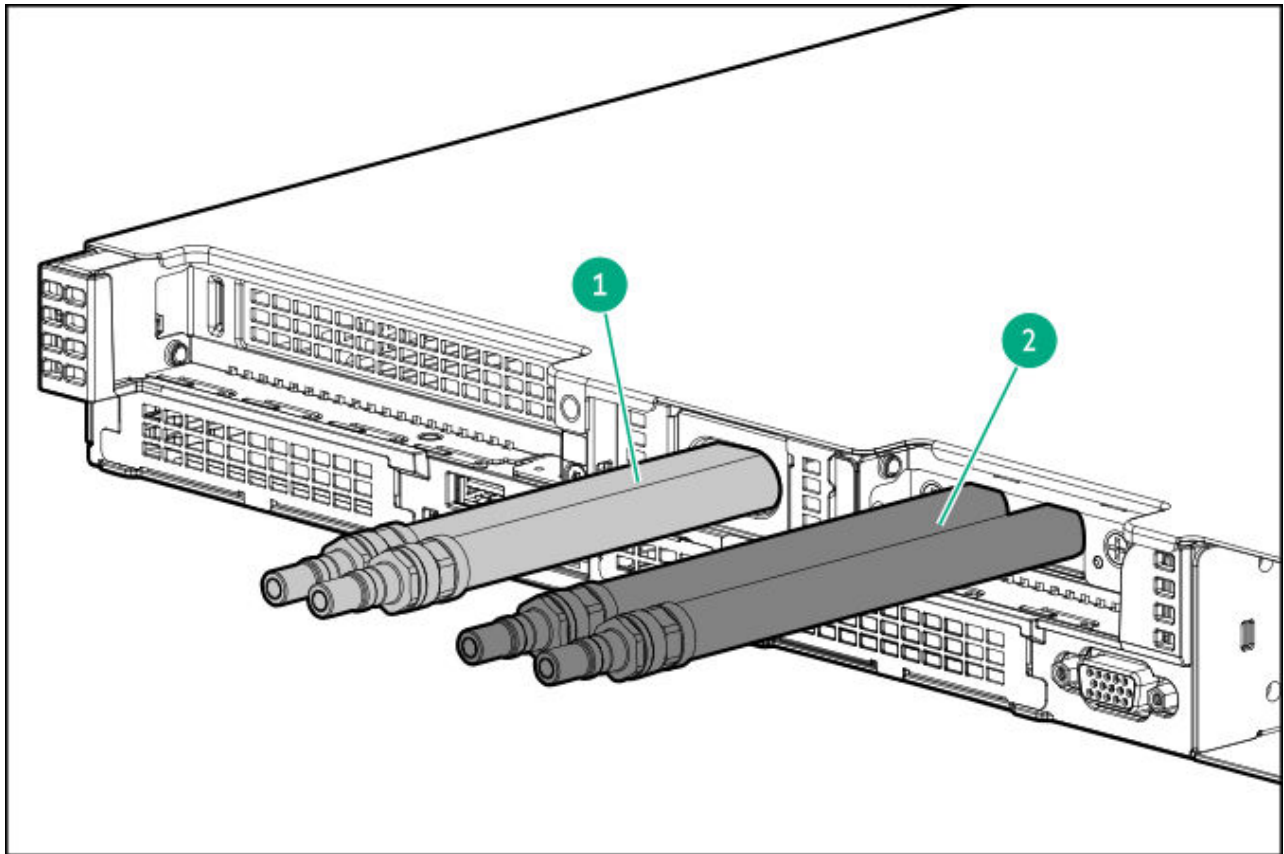

Item	Description
1	Coolant hoses coming from the rear NS204i-u bracket
2	Coolant hoses coming from PCIe Slot 3

2. Position the towels or container under the hoses and then disconnect the quick connect hoses.

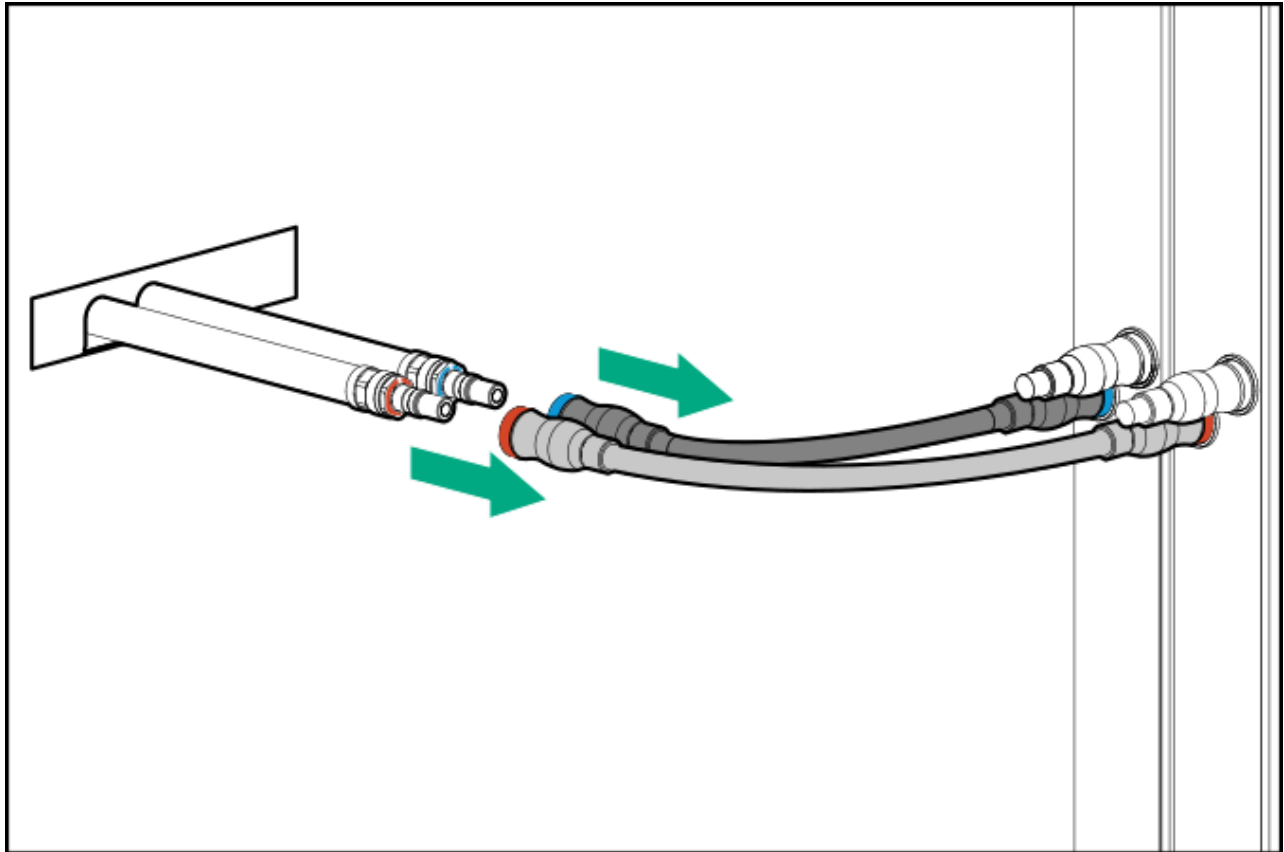

3. Install the quick connect caps.



Installing the DLC cold plate module on the system board

Prerequisites

- Read the HPE Cray XD/ProLiant Direct Liquid Cooling System Site Preparation, User and Maintenance Guide:

<https://www.hpe.com/info/xdDLCguide>

- Review the following:
 - [DLC module components](#)
 - [Heatsink and processor socket components](#)

1.
 - [Processor cautions](#)
 - [Eye and skin protection](#)
- If the reason for replacing the DLC module is due to a coolant leak, first perform the [Appendix I: Server coolant spill response procedure](#).
- In addition to the tools and materials required for the DLC system, be sure that you also have the following:
 - Liquid cooling module handle (spare part number: P89110-001)
 - T-30 Torx screwdriver
 - T-10 Torx screwdriver

About this task



CAUTION

A discharge of static electricity from a finger or other conductor might damage system boards or other static-sensitive devices. To prevent damage, observe [antistatic precautions](#).

Procedure



IMPORTANT

If you are installing or replacing the liquid cooling module in a system using the one-processor configuration, note the following:

- To prevent any interference issues, remove the dust covers from both processor sockets before installing the cold plates.
- Do not touch or remove the thermal interface material on the contact side of the cold plate that does not have a processor-carrier assembly installed.

If installed, remove the dust covers from the processor sockets:

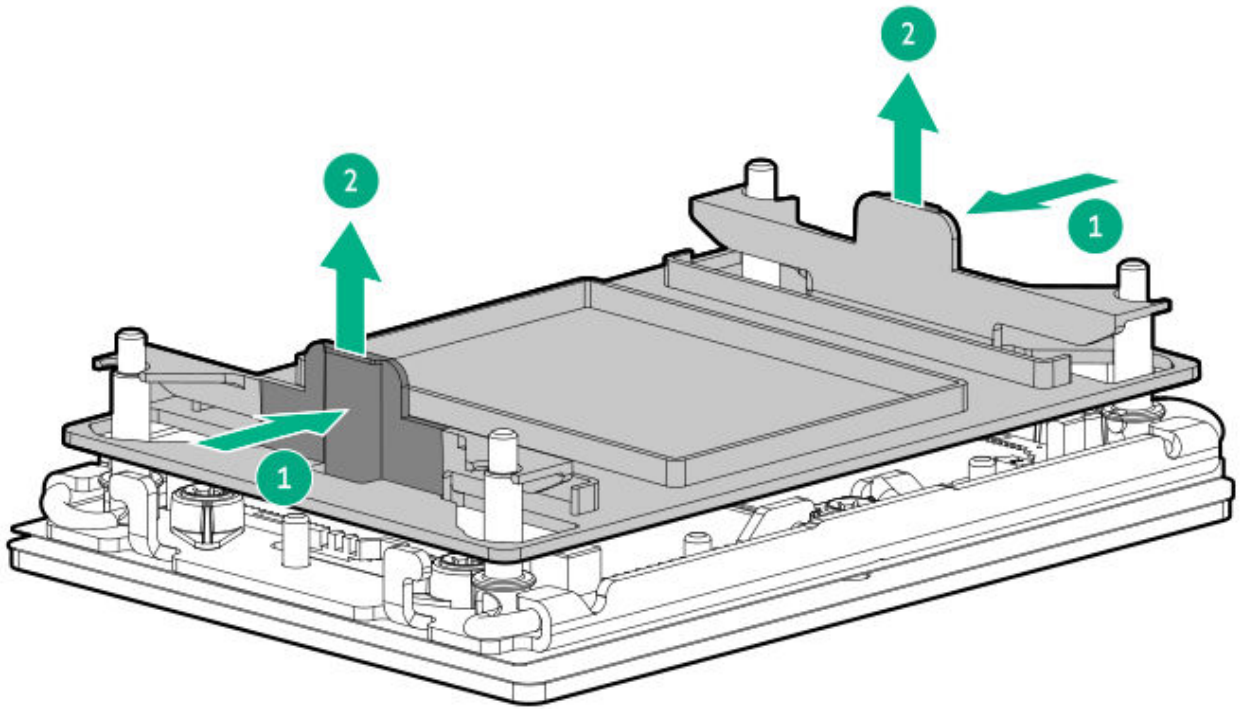

2. Do not touch the pins on the processor socket and the processor.



CAUTION

THE PINS ON THE PROCESSOR SOCKET AND ON THE PROCESSOR ARE VERY FRAGILE AND EASILY DAMAGED. Any damage to them might require replacing the system board.

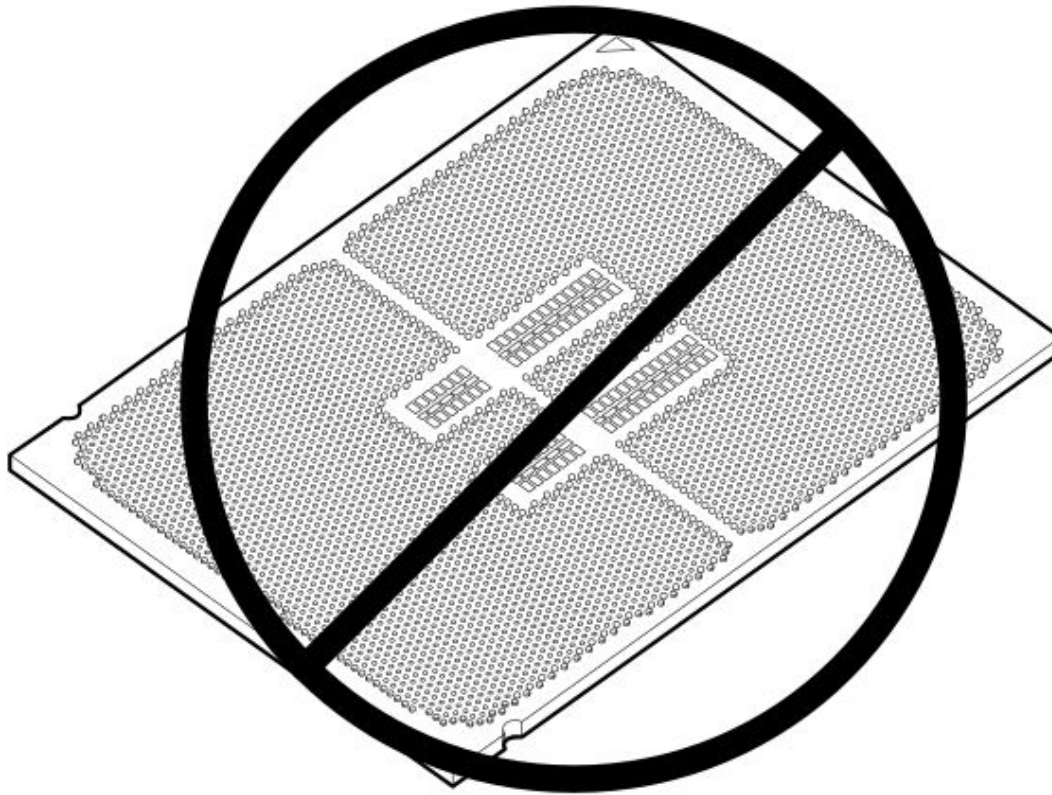
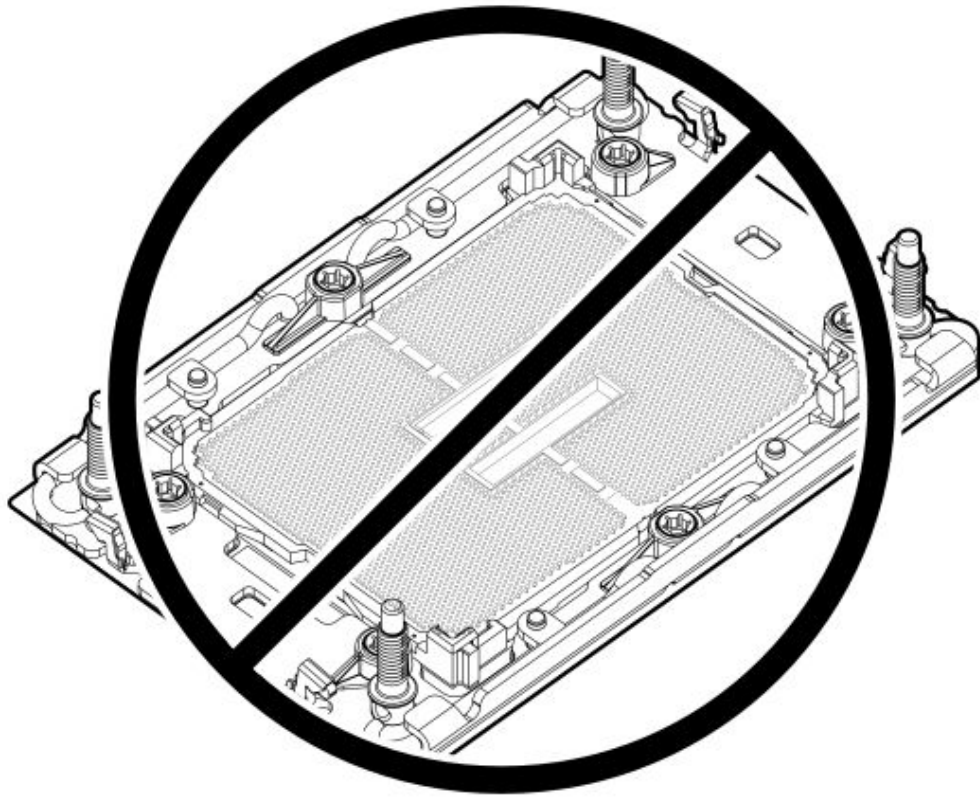

3. Set the liquid cooling module handle to the appropriate length.
 - a. Disengage the locking handle.
 - b. Extend the handle and align the edge to the line marked by the letter E.
 - c. Engage the locking handle.

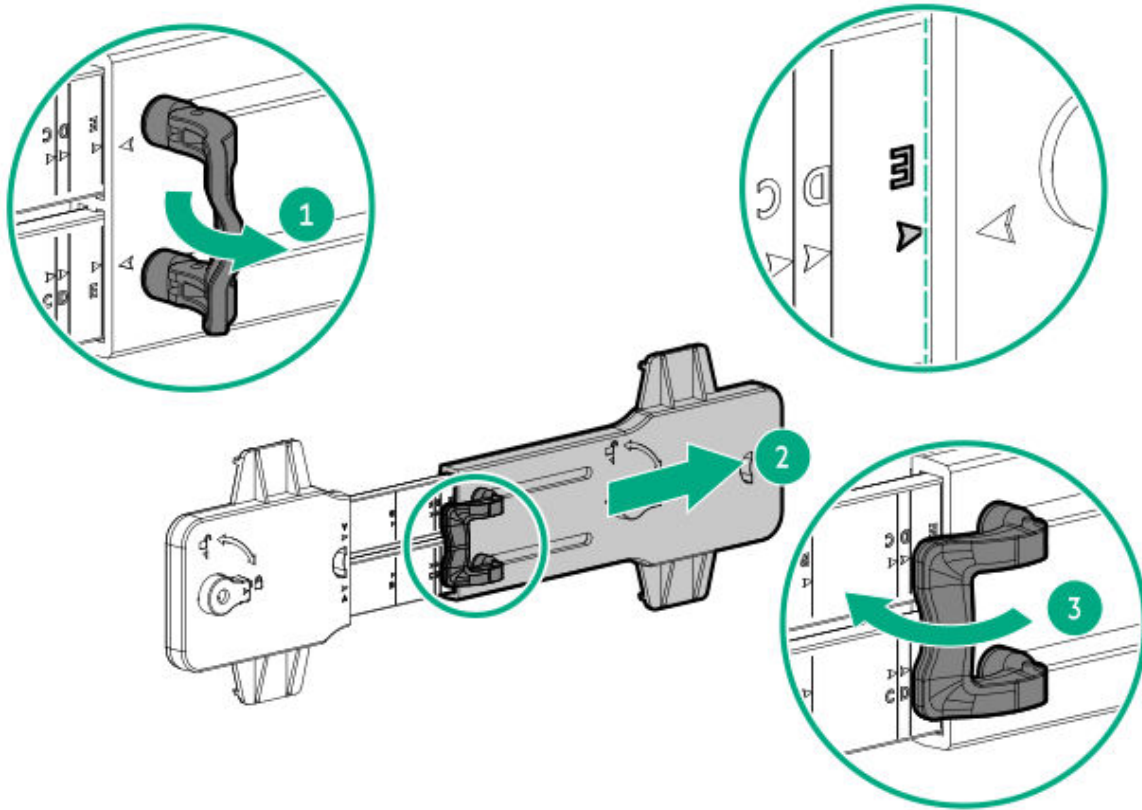

4. Attach the handle to the open-loop liquid cooling cold plates:
 - a. Rotate the handle knobs anti-clockwise to the unlocked position.

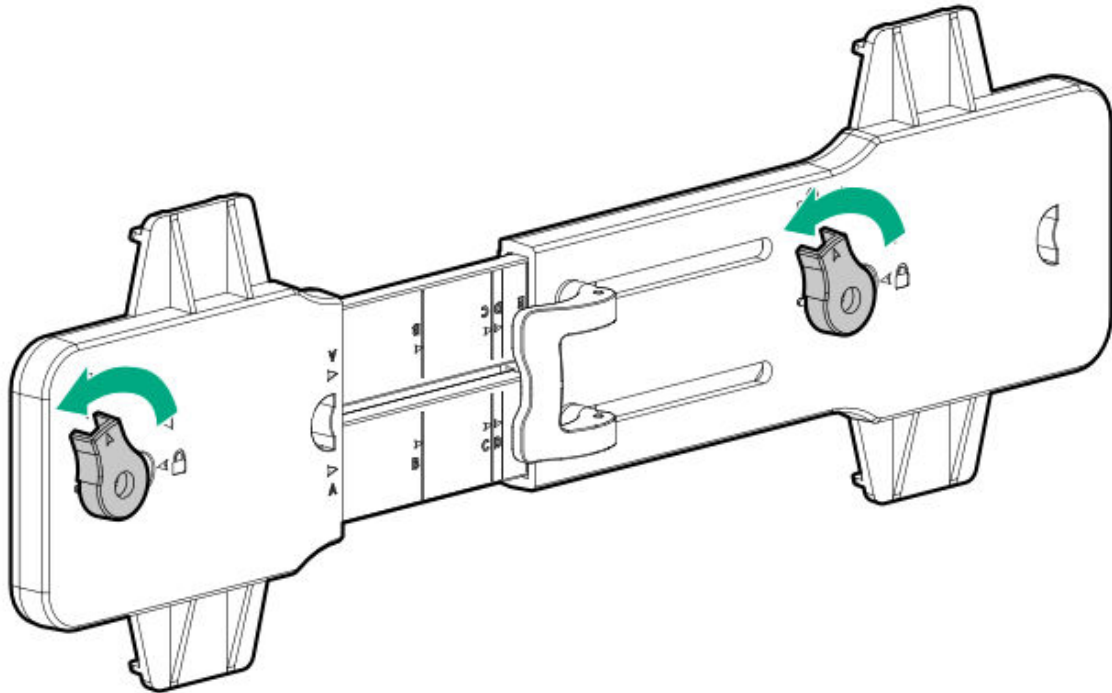

- b. Align the hooks on the handle with the notches on the cold plates, and then attach the handle to the cold plates.

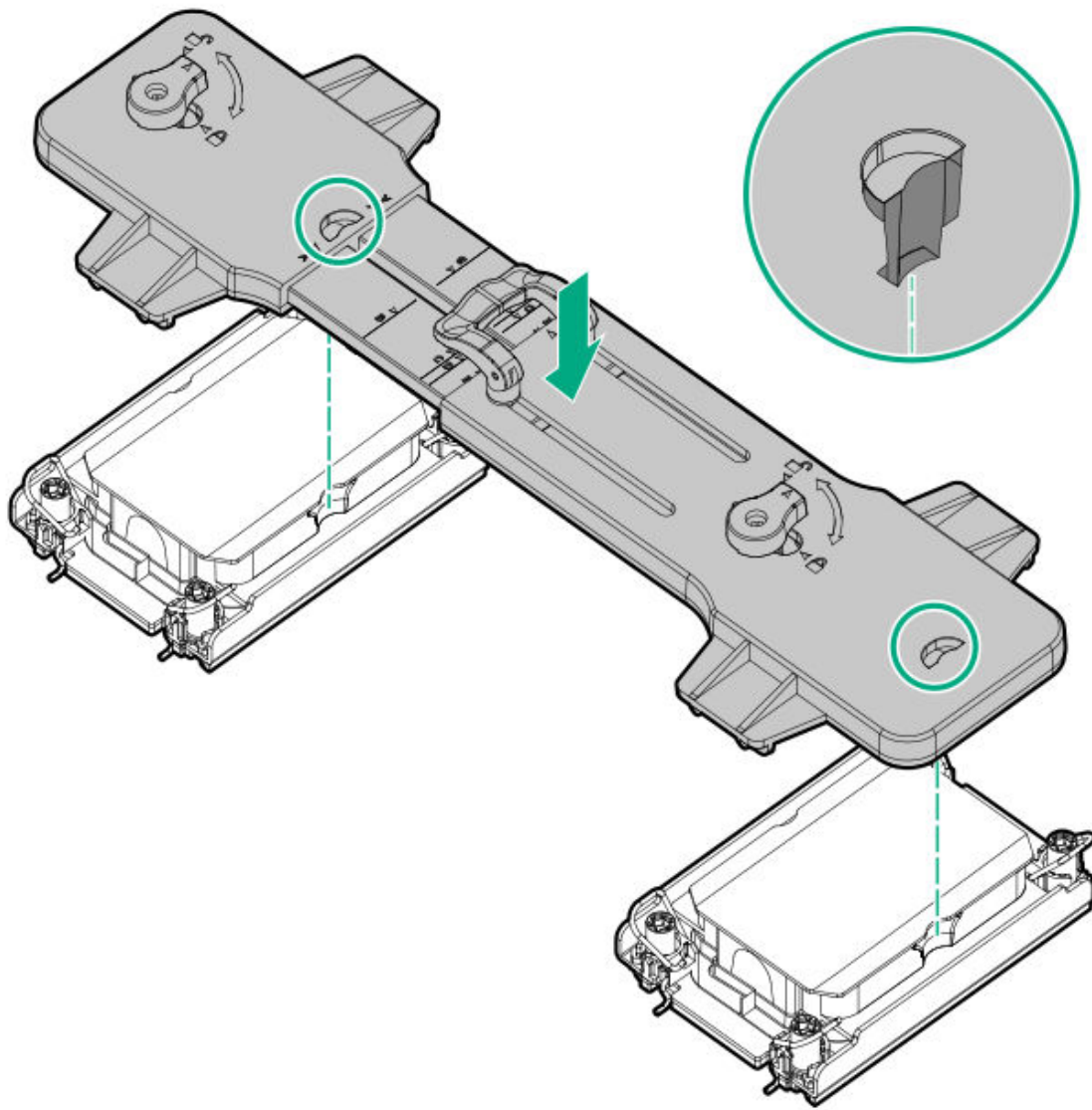

c. Turn the handle knobs to the locked position.

Gently pull on the handle and verify that the cold plates are securely latched to the handle.

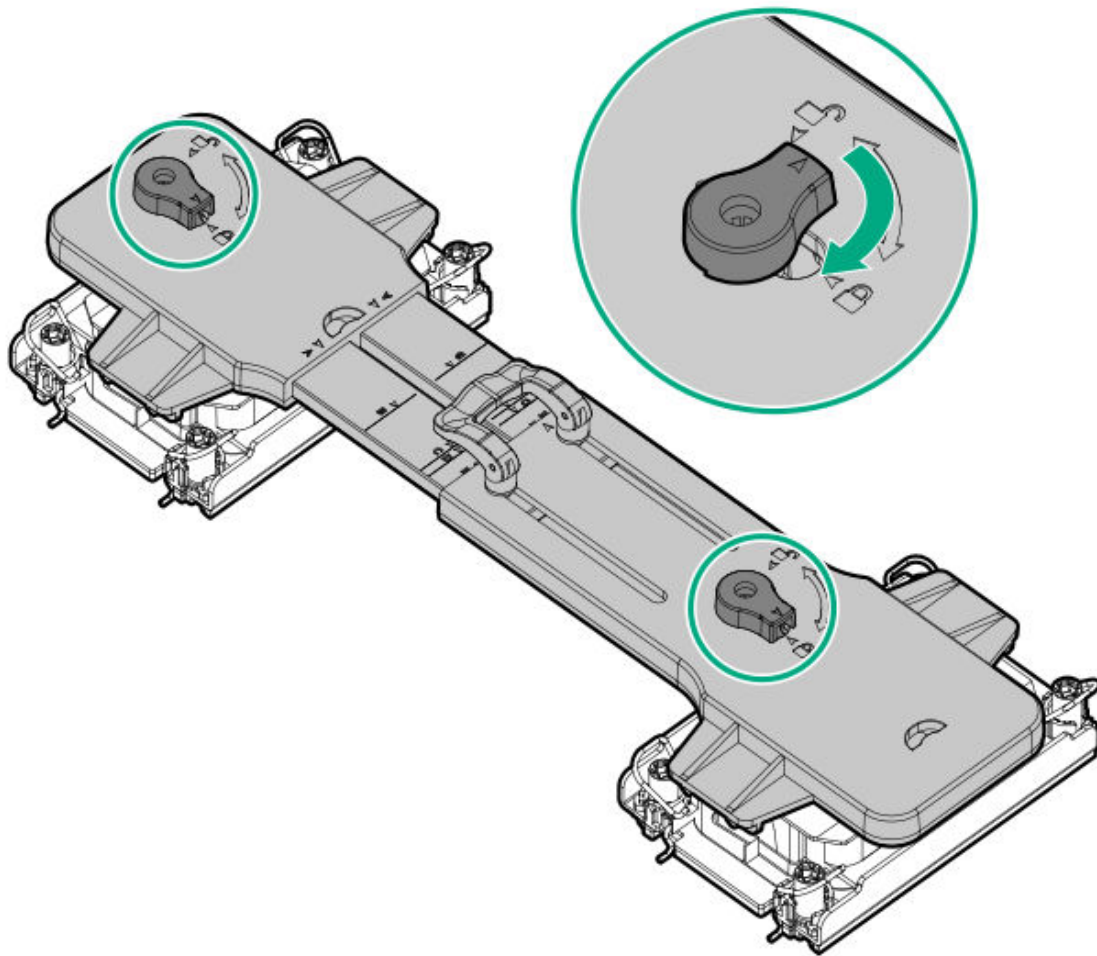

5.



CAUTION

To avoid damaging the coolant hoses that might result in a coolant leak, do not bend the coolant hoses when installing or removing the liquid cooling module.

Prepare the DLC module for installation.

- DLC cold plate module and PCIe bracket:

Install the DLC cold plate module and PCIe bracket in the low-profile riser cage.



- DLC cold plate module and NS204i-u bracket:

Install the DLC cold plate module on the NS204i-u bracket and primary riser cage.

There will be an audible click to indicate that the hose bracket is properly latched on the NS204i-u bracket.

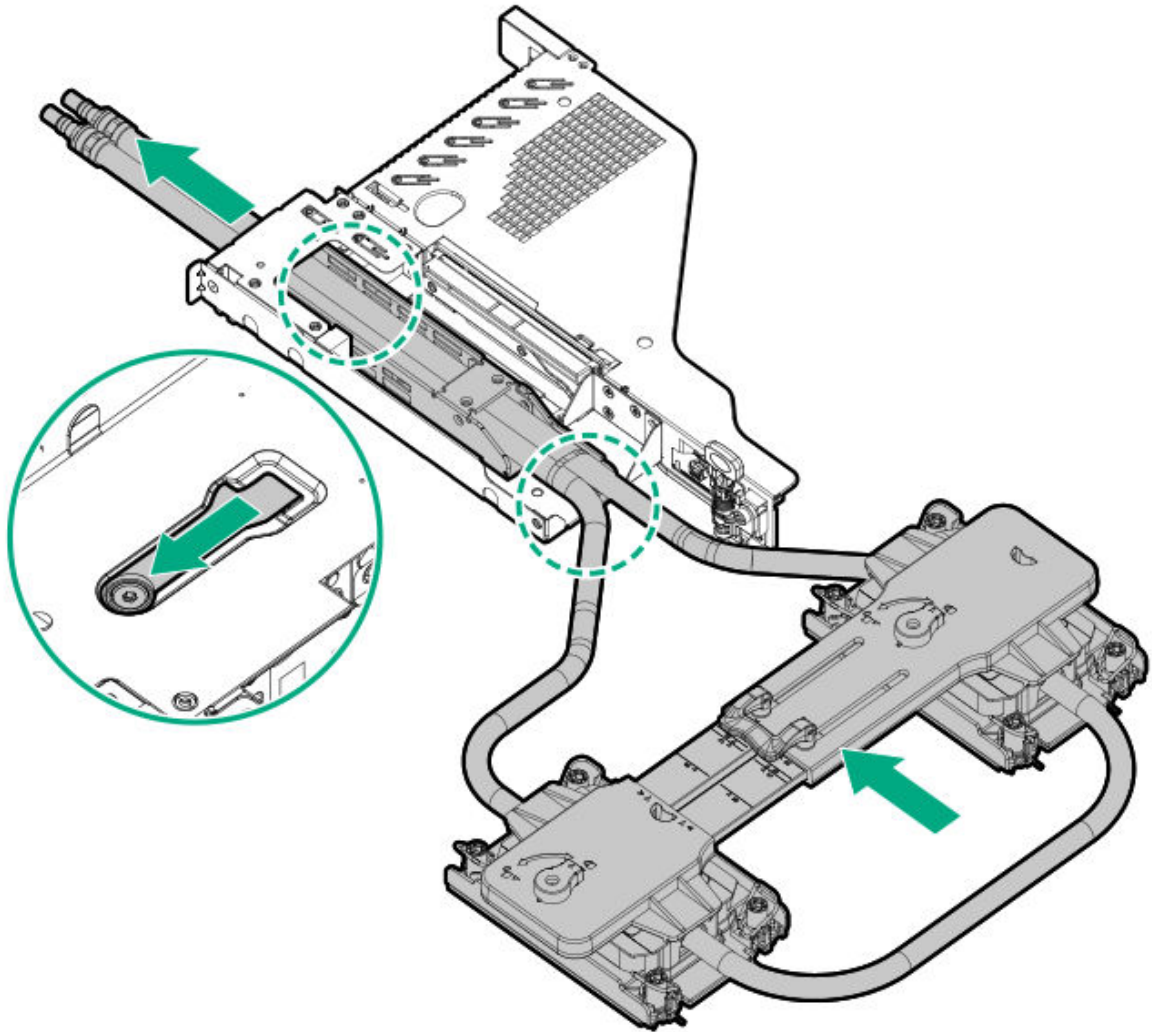

6. Set the direct liquid cooling assembly upside down on a flat surface.

- DLC cold plate module and PCIe bracket:



- DLC cold plate module and NS204i-u bracket:

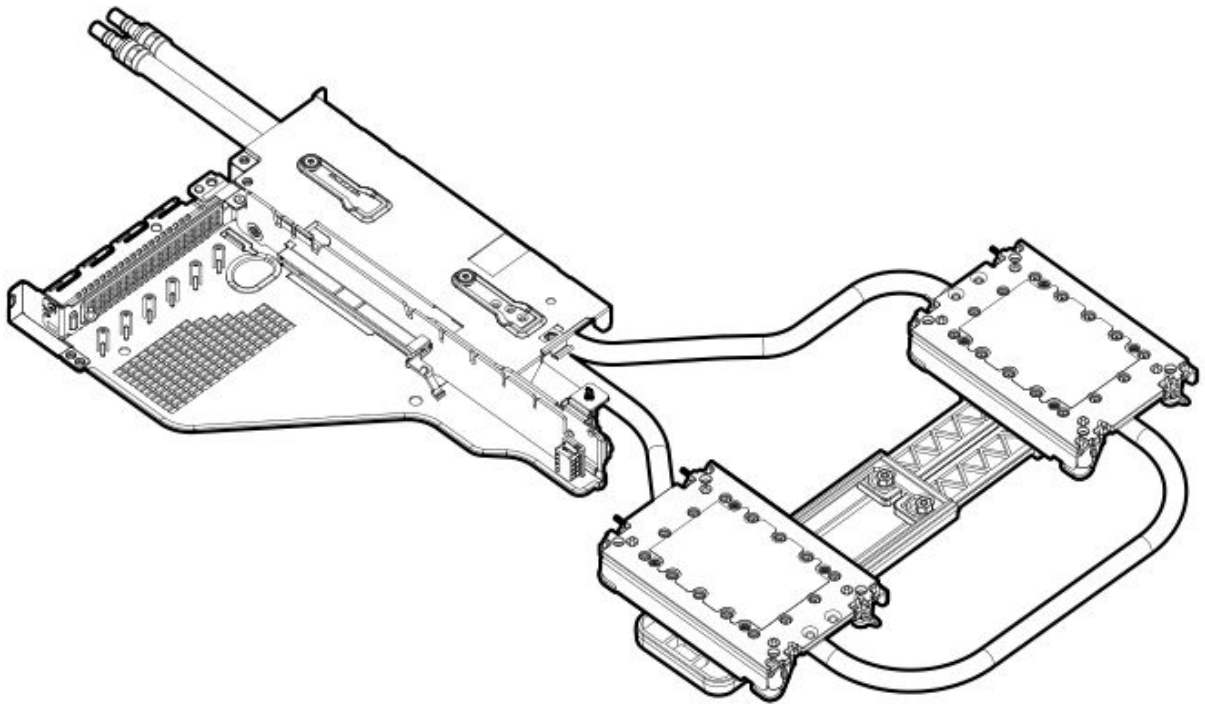

7. Remove the clear protective covers from the new open-loop liquid cooling cold plates.
8. Install the processor carrier on the processor:
 - a. Align the pin 1 indicator on the processor carrier with that on the processor, and then press on the pair of opposite sides on the TIM breaker lever of the processor carrier until it clicks into place.

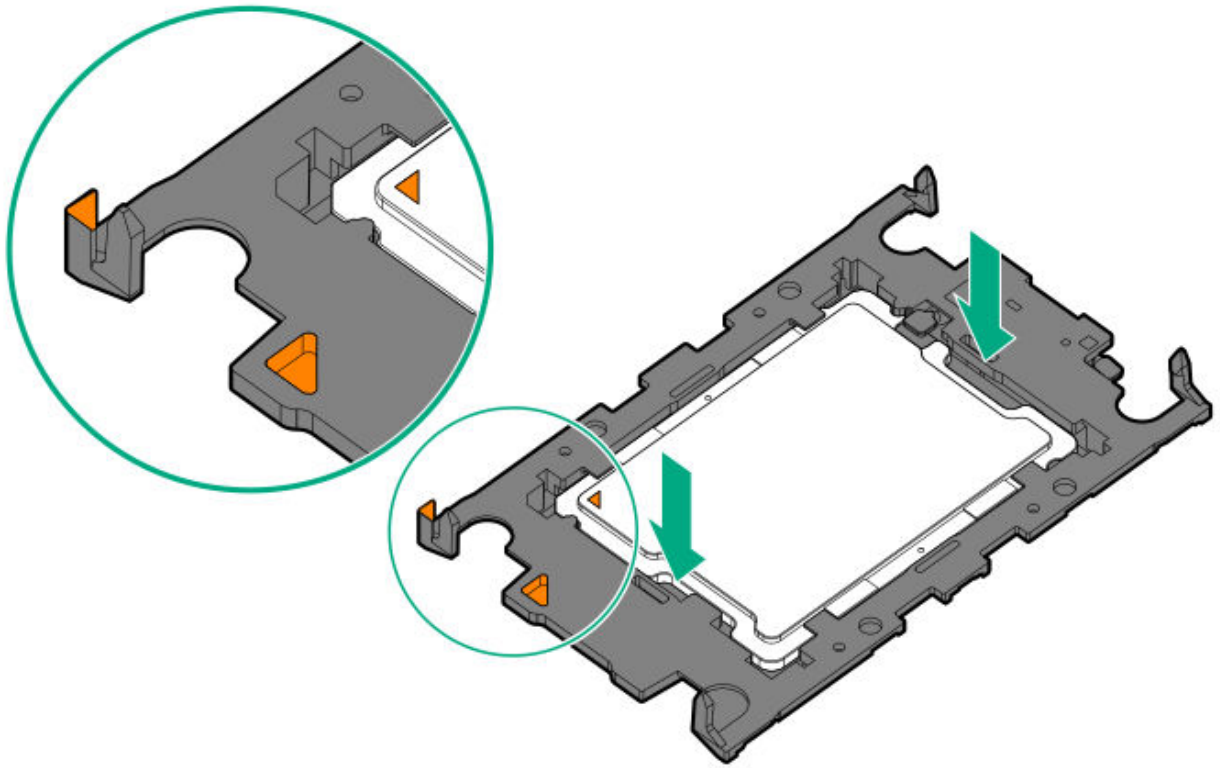

b. Verify that the processor is properly latched on the processor carrier.

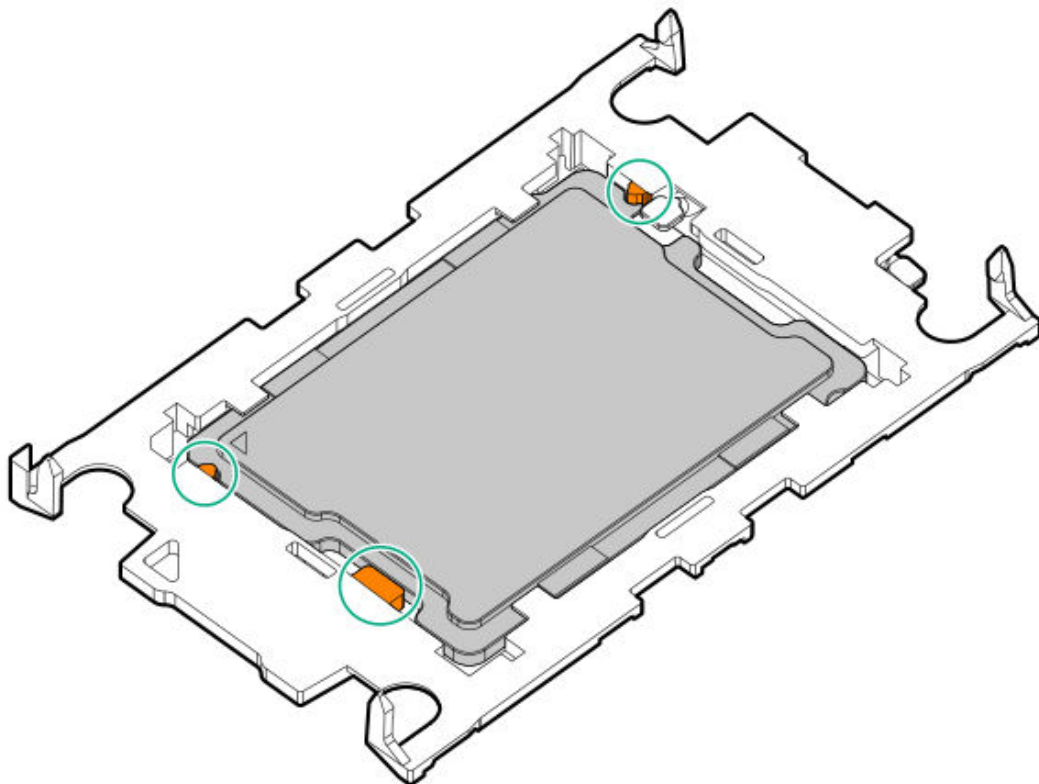

If not, press the other pair of opposite sides of the processor carrier until it clicks into place.

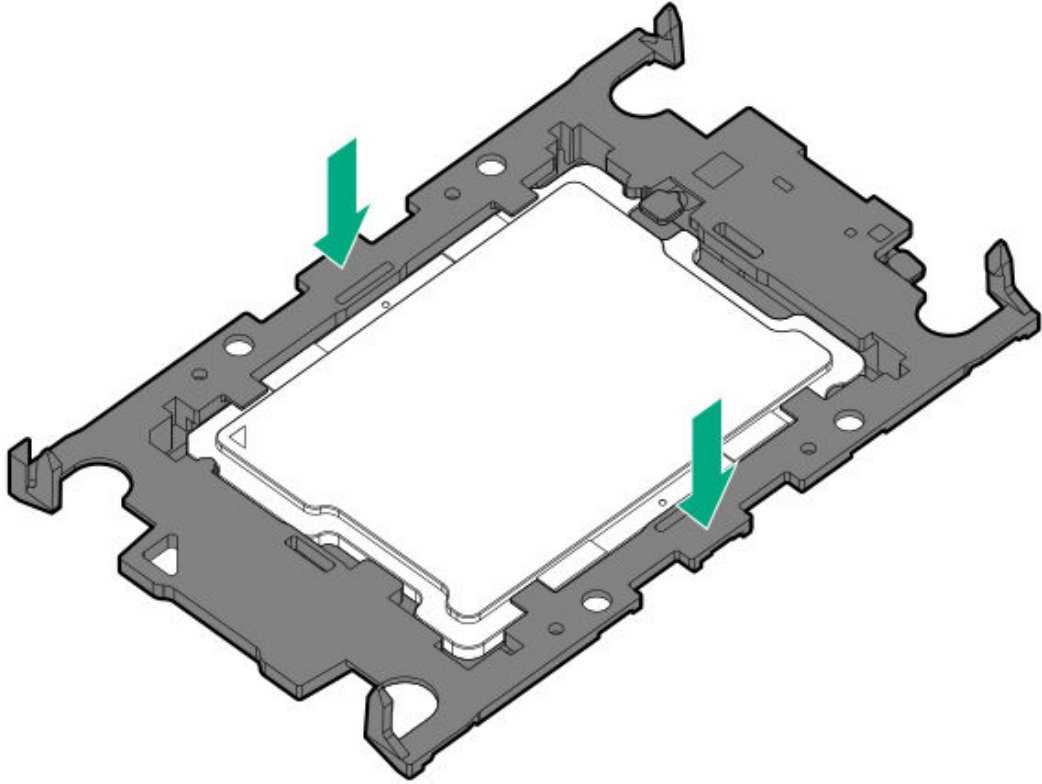

9. Attach the processor carrier to the DLC cold plate module:
 - a. Align the pin 1 indicator on the processor carrier with that of the cold plate.

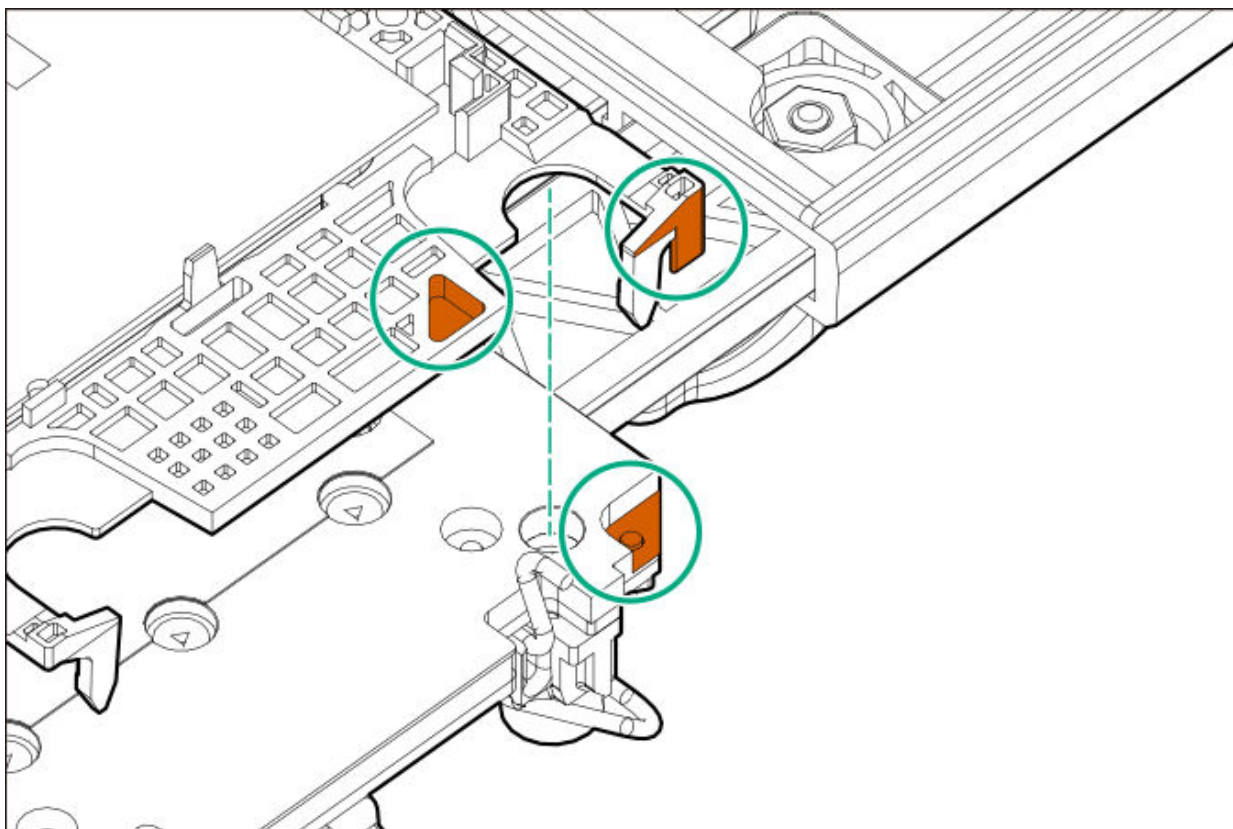

- b. Lower the processor carrier on the cold plate until the carrier tabs snap into place.

There will be an audible click to indicate that the processor carrier is properly latched on the cold plate.

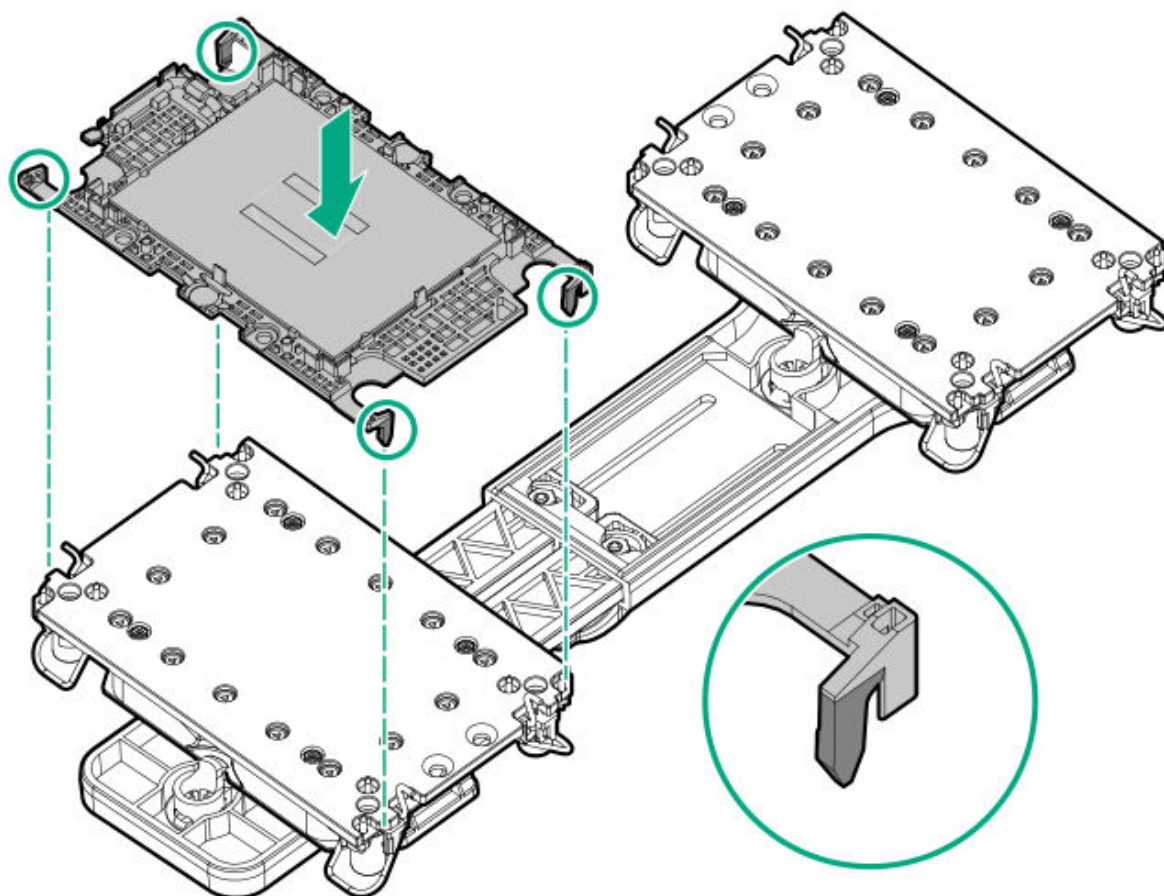

- .0. If you want to install a second processor, repeat the previous two steps.
- .1. Perform the following verification steps:
 - a. Verify that the tabs on the processor carrier are securely latched on the cold plate.

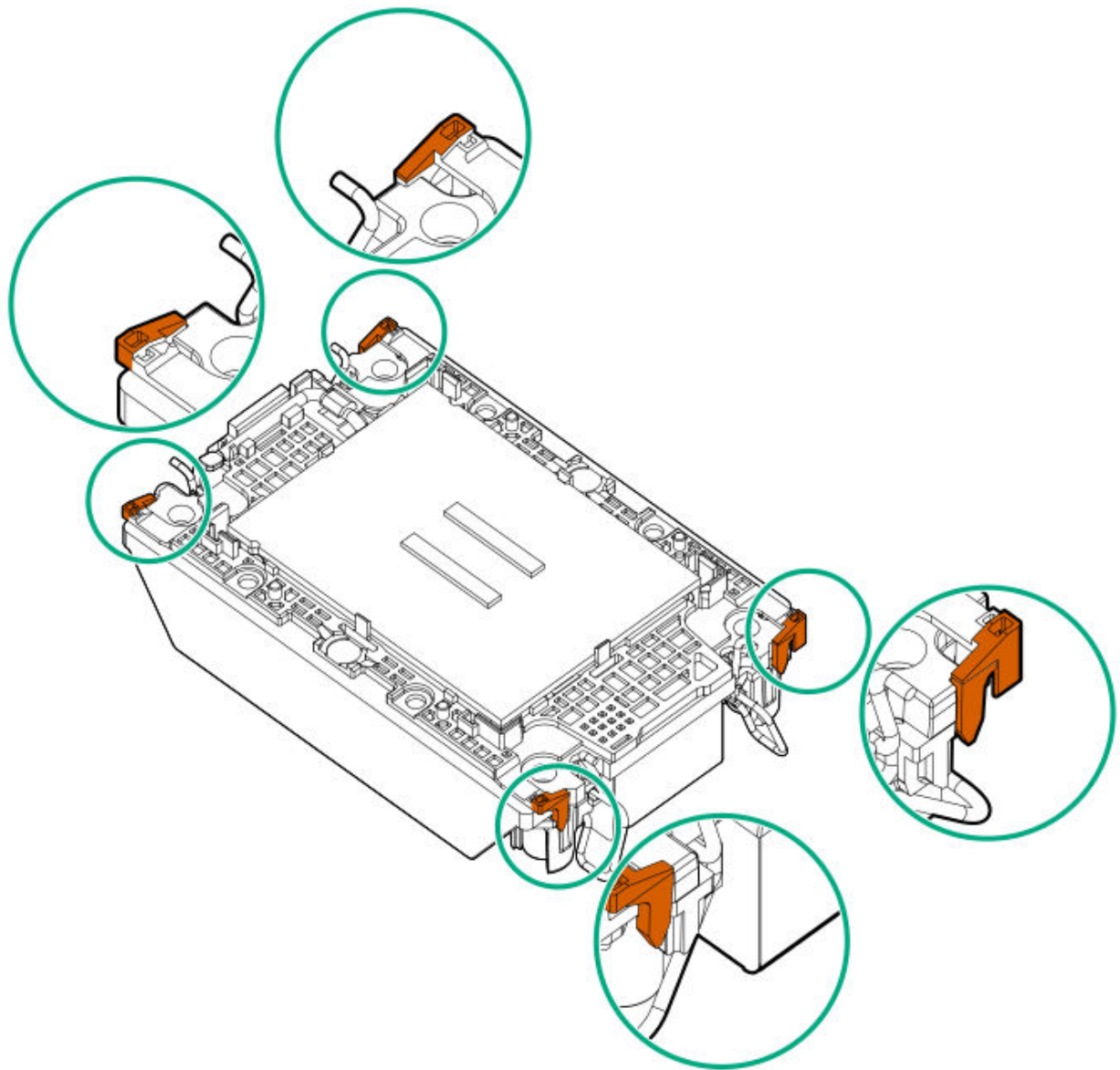

b. Verify that the pin 1 indicators on the processor and processor carrier are aligned.

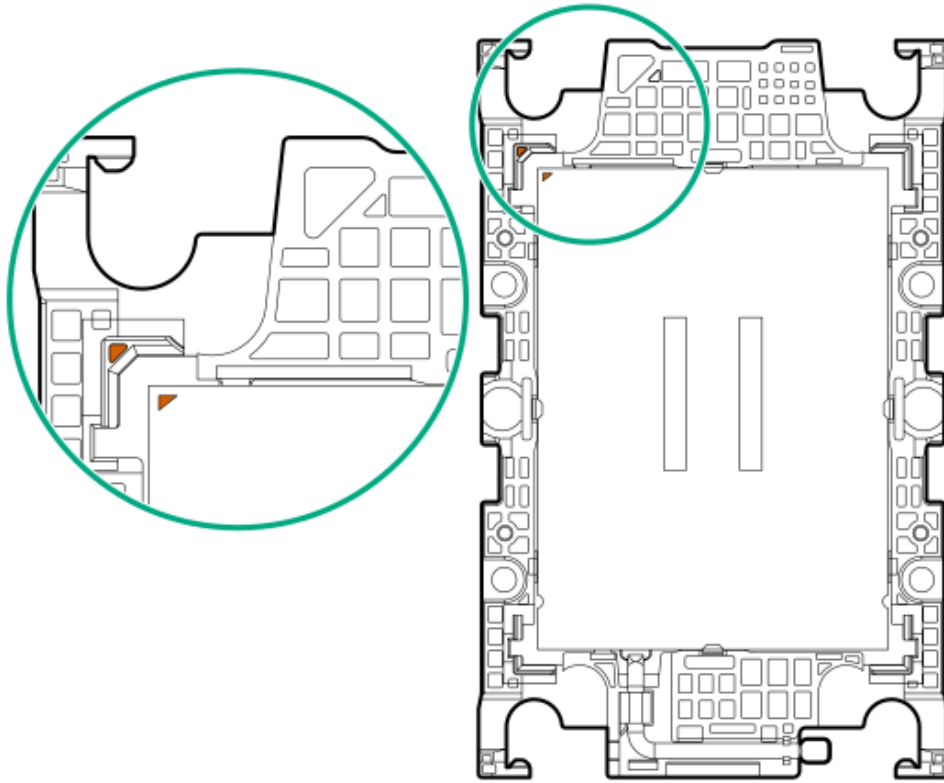

c. Verify that the processor is properly secured by the carrier snaps.

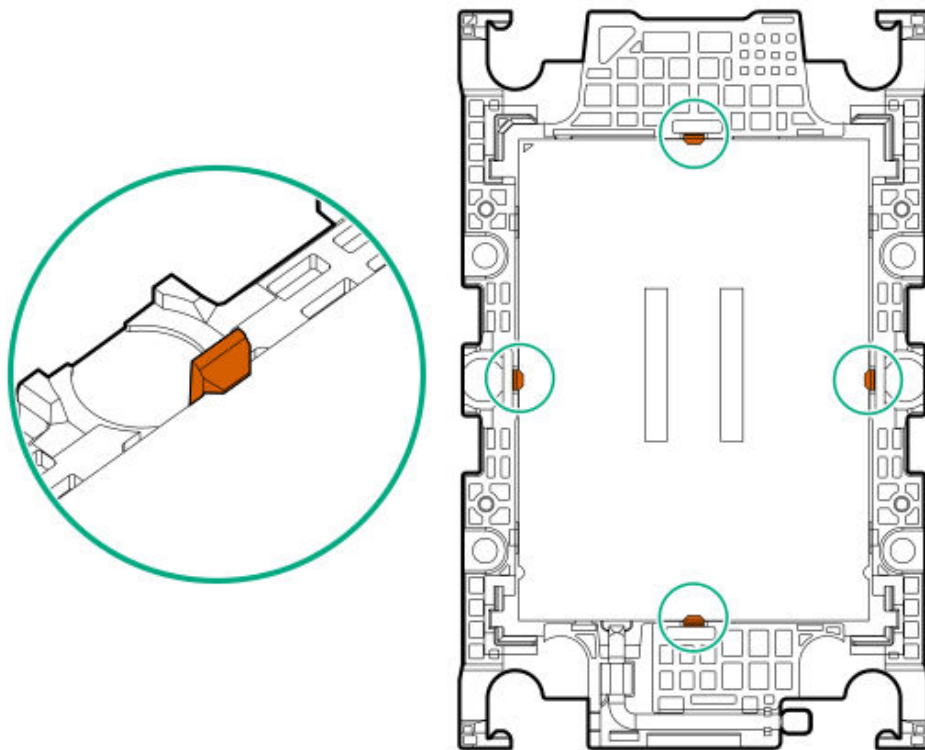

.2.



CAUTION

Extra caution is required when you are handling the liquid cooling module or processor-carrier assembly during its installation or removal process. **THE PINS ON THE PROCESSOR SOCKET AND ON THE PROCESSOR ARE VERY FRAGILE AND EASILY DAMAGED.**



CAUTION

To avoid damaging the coolant hoses that might result in a coolant leak, do not bend the coolant hoses when installing or removing the liquid cooling module.

Place the liquid cooling module on the system board. Set the riser cage on the slot while you install the cold plates.

- DLC cold plate module and PCIe bracket:

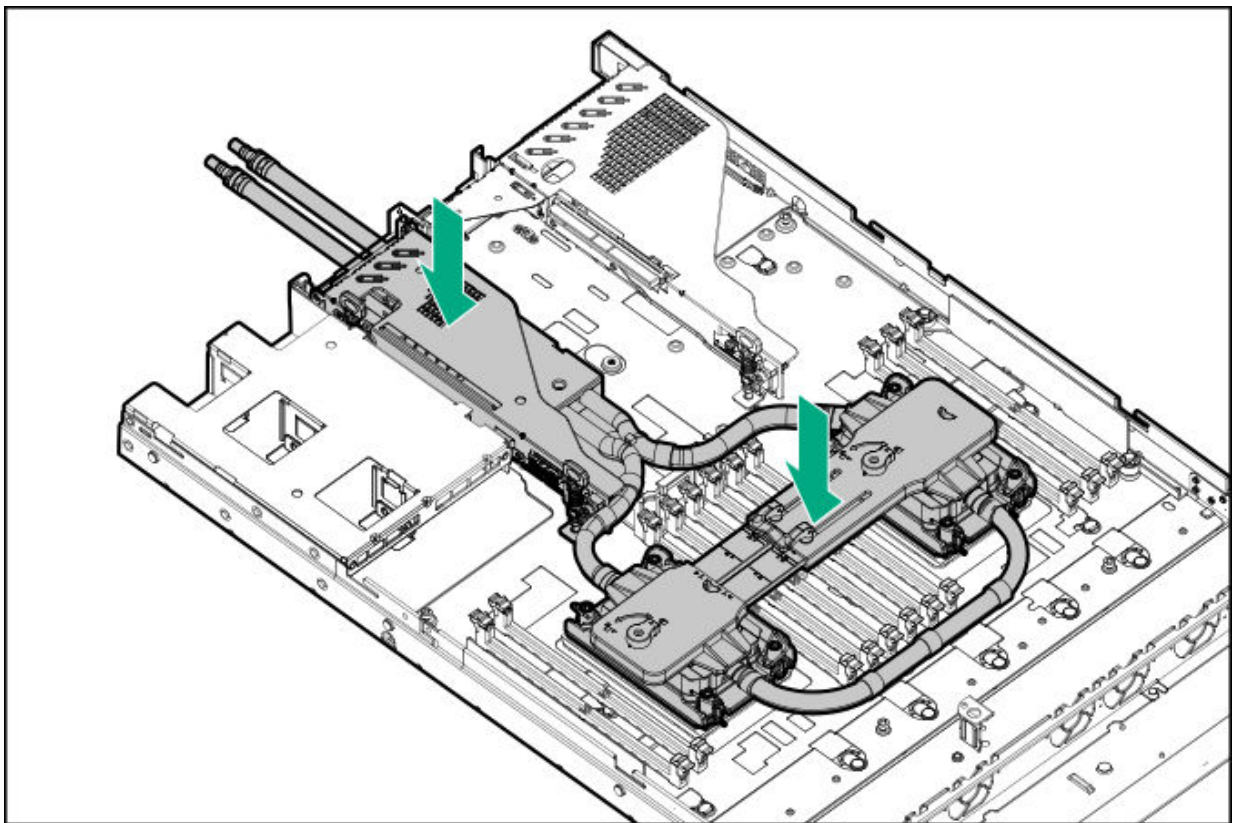

- DLC cold plate module and NS204i-u bracket:

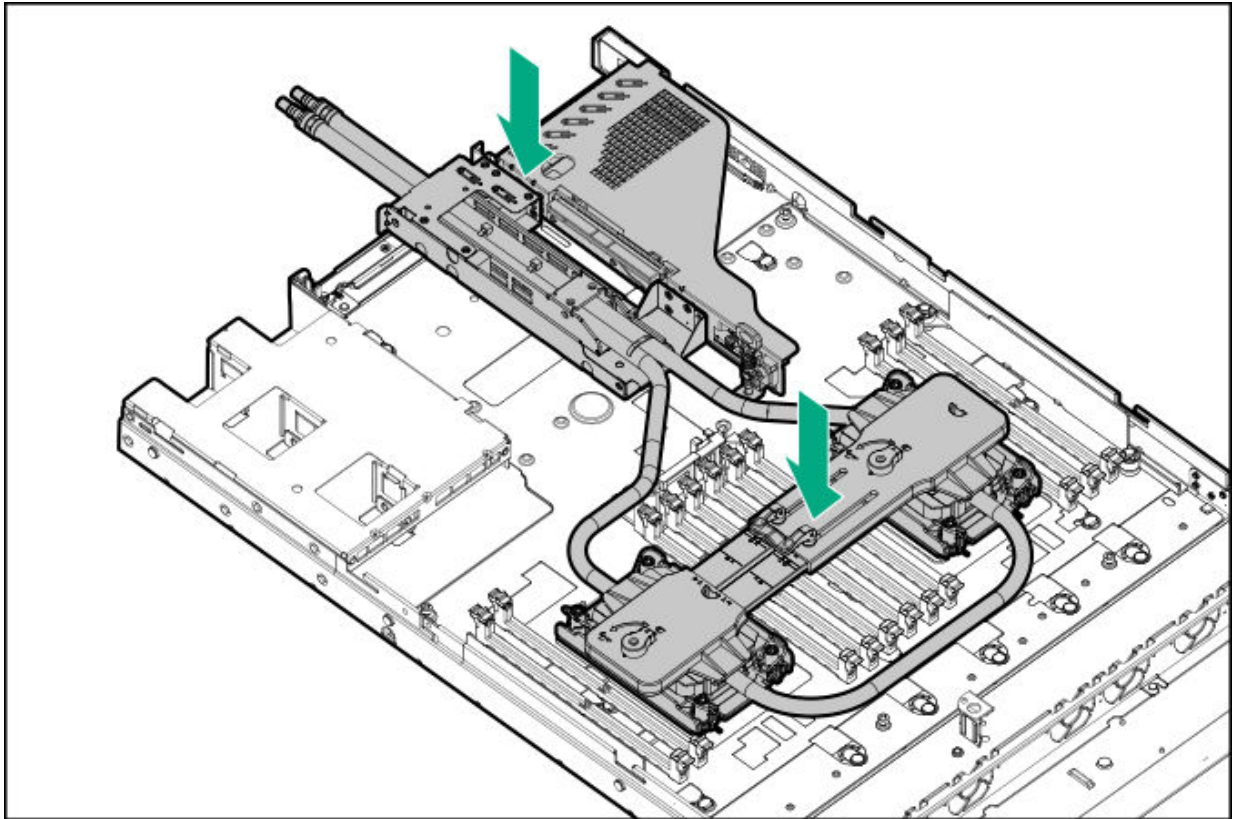

.3. Tighten the screws on both cold plates:

- a. When using a torque screwdriver to tighten the cold plate screws, set 0.9 N-m (8 in-lb) of torque.
- b. Note the **Front of server** text on the cold plate label to correctly orient the cold plate over the bolster plate.
- c. Carefully lower the cold plate onto the bolster plate guide posts.

The posts are keyed so that the module can only be installed one way. Make sure that the module is properly seated on the bolster plate before securing the screws.

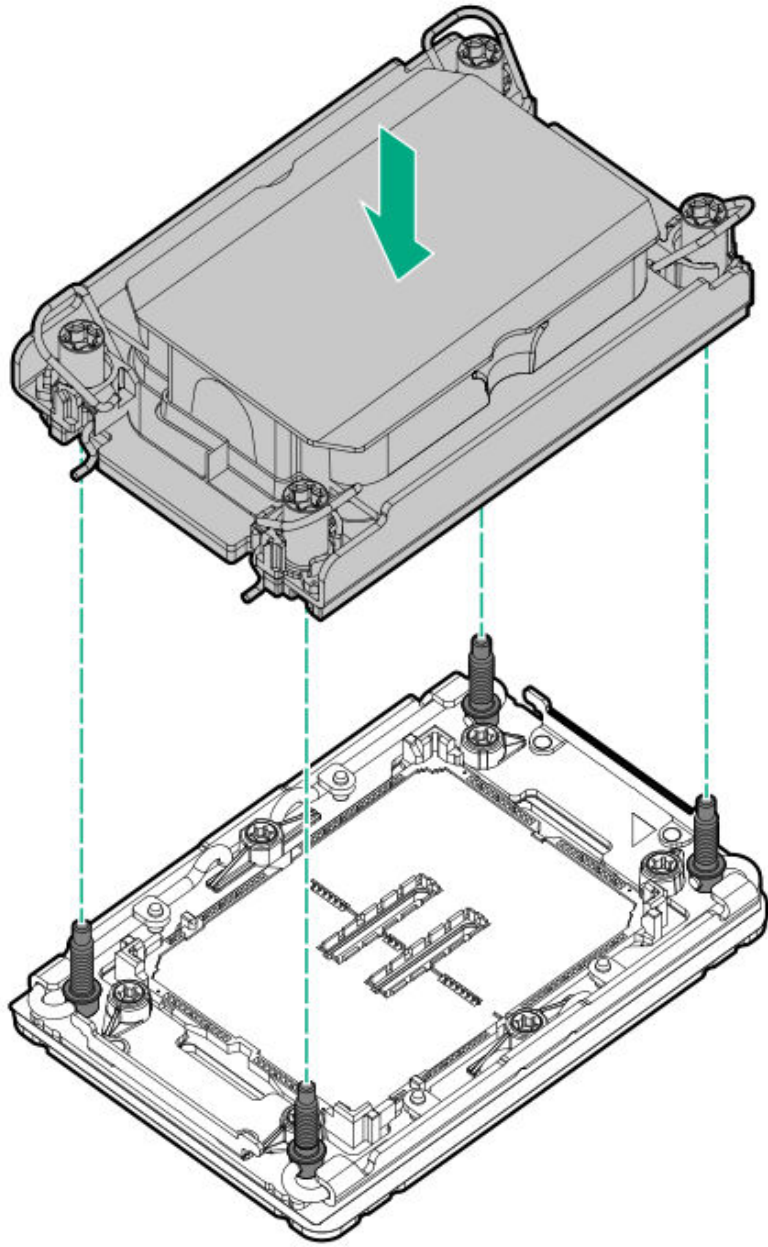

d. Set the anti-tilt wires to the locked position.

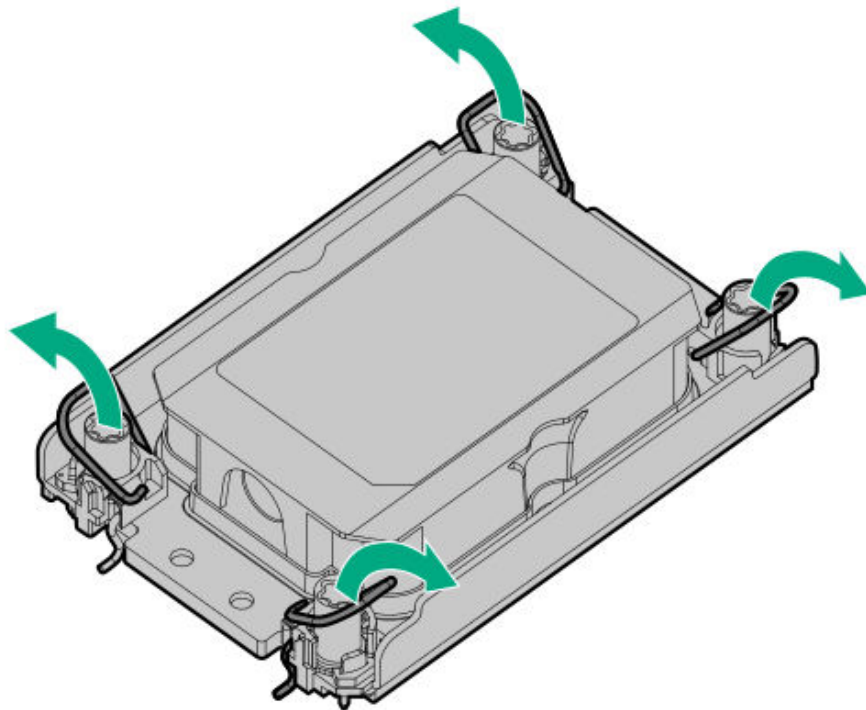

e. Tighten the cold plate screws.

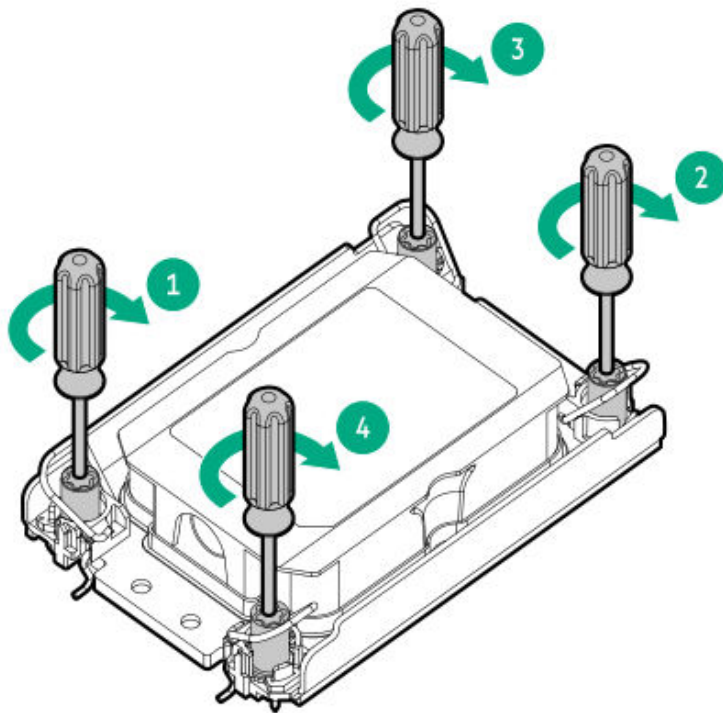

4. Install the riser cage.

- Secondary riser cage:

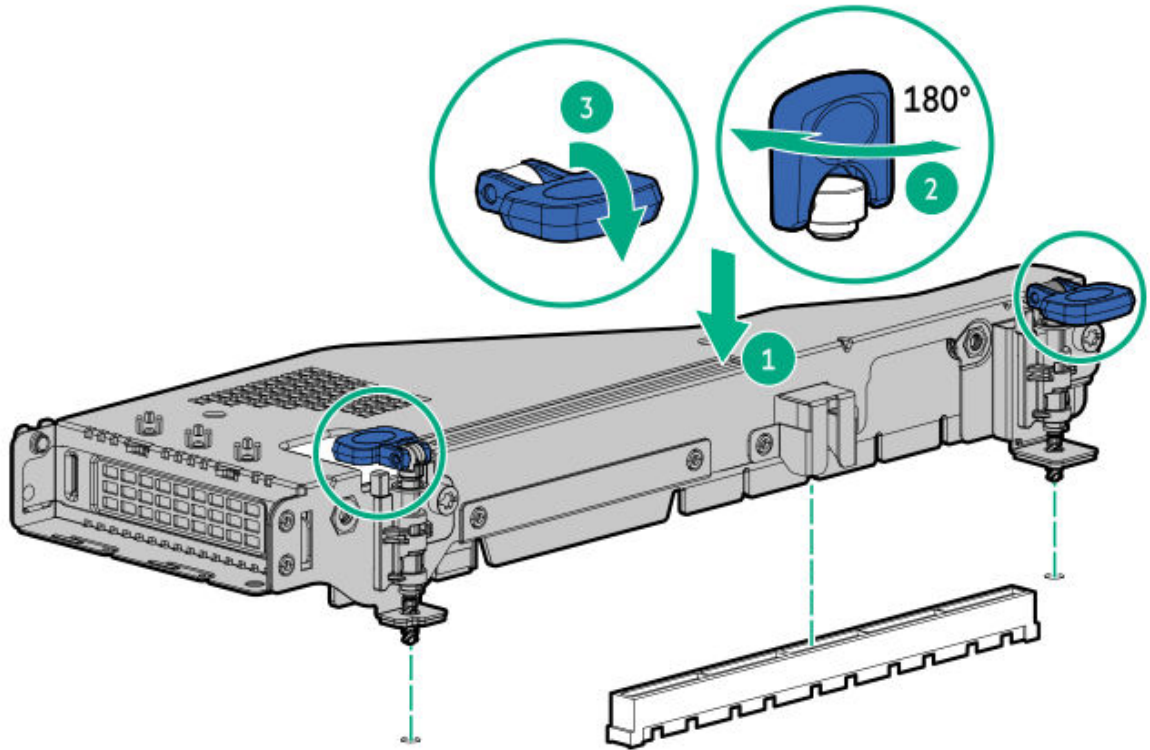

- Primary riser cage with NS204i-u bracket installed:

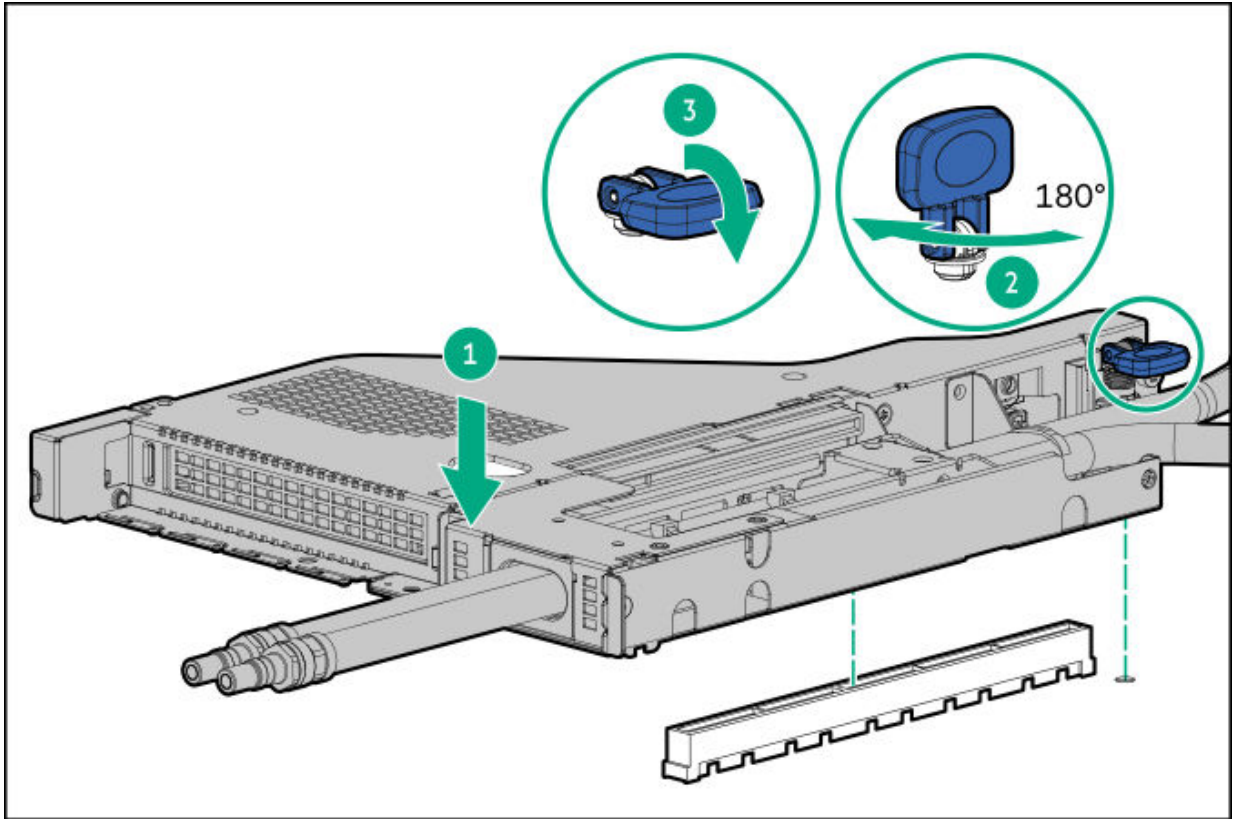

.5. Remove the handle from the cold plates.

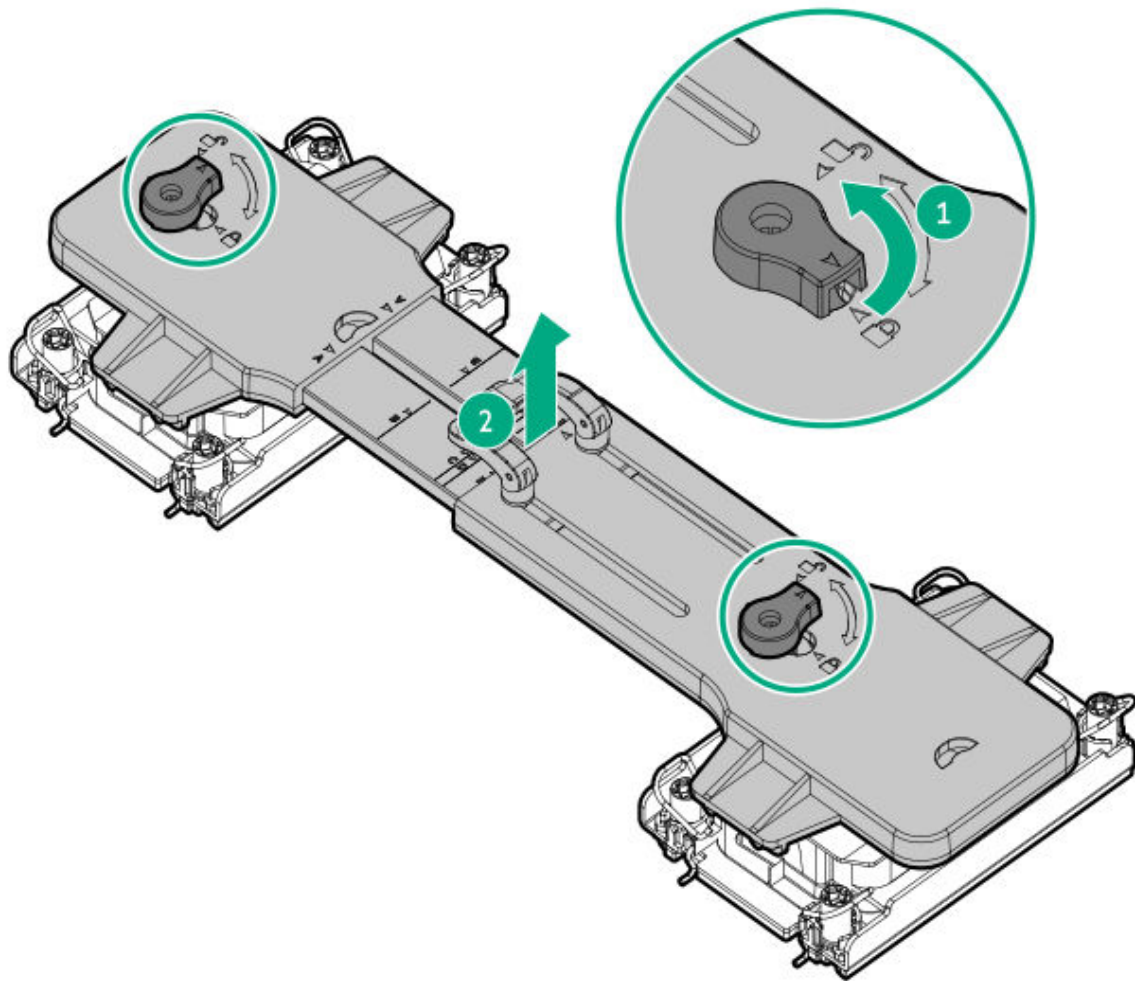

- .6. Connect the signal cable to the system board.
- .7. Install the access panel.
- .8. If the server was removed from an enclosure or a rack, reinstall it now.
- .9. Connect the direct liquid cooling kit from the DLC manifold to the server.
- !0. Connect all peripheral cables to the server.
- !1. Connect each power cord to the server.
- !2. Connect each power cord to the power source.
- !3. Power up the server.

Checking coolant level

- !4. After powering up the server, wait for a few minutes for the system to stabilize.
- !5. Check the coolant level in the coolant distribution unit (CDU).

!6. If the coolant feed (CF) pump reservoir bag is empty, or the return pressure is ≤ 10 PSIG, do one of the following:

- Refill the CF pump reservoir bag.
- Refill the system using a hand pump.

For detailed procedures, see the CDU documentation.

Results

The replacement procedure is complete.

Processor replacement

Subtopics

Processor cautions

Removing a processor

Installing a processor

Processor cautions



CAUTION

To avoid damage to the processor or system board, only authorized personnel should attempt to replace or install the processor in this server.



CAUTION

To prevent possible server malfunction and damage to the equipment, multiprocessor configurations must contain processors with the same part number.



CAUTION

The pins on the processor socket and on the processor are very fragile and easily damaged. To avoid component damage, **do not touch these pins.** Any damage to them might require replacing the system board and/or processor.



IMPORTANT

Processor socket 1 must be populated at all times or the server does not function.



IMPORTANT

If installing a processor with a faster speed, update the system ROM before installing the processor. To download firmware, go to the Hewlett Packard Enterprise Support Center website (<https://www.hpe.com/support/hpesc>).

Removing a processor

Prerequisites

- Identify the heatsink and processor socket components.
- Review the processor cautions.
- Before you perform this procedure, make sure that you have the following items available:
 - T-30 Torx screwdriver or a bit driver with T-30 Torx bit
 - Alcohol wipe

- Liquid cooling module handle—This is needed only if the system has a liquid cooling module installed. Use this handle to facilitate the removal and installation of the liquid cooling module when replacing the processor, system board, or liquid cooling module.

The handle can be ordered as a spare (P89110-001).

- If you are not immediately installing the replacement processor-heatsink assembly, make sure that you have a processor socket dust cover.

About this task



WARNING

To reduce the risk of personal injury from hot surfaces, allow the internal system components to cool before touching them.



CAUTION

A discharge of static electricity from a finger or other conductor might damage system boards or other static-sensitive devices. To prevent damage, observe antistatic precautions.

Procedure

1. Power down the server.
2. Remove all power:
 - a. Disconnect each power cord from the power source.
 - b. Disconnect each power cord from the server.
3. If the system uses direct liquid cooling, disconnect the DLC kit from the rack manifold.
4. If the server is installed in an enclosure or a rack, remove the server and place it on a flat, level work surface.
5. Remove the access panel.
6. Allow all internal system components to cool before continuing.
7. If the system uses standard or high performance heatsinks, proceed to step 8.

If the system has a liquid cooling module installed, remove the liquid cooling module and then remove the processor from the cold plate.

8. If installed, remove the air baffle.

An 8 SFF server is shown. The removal procedure is the same for all drive configurations.

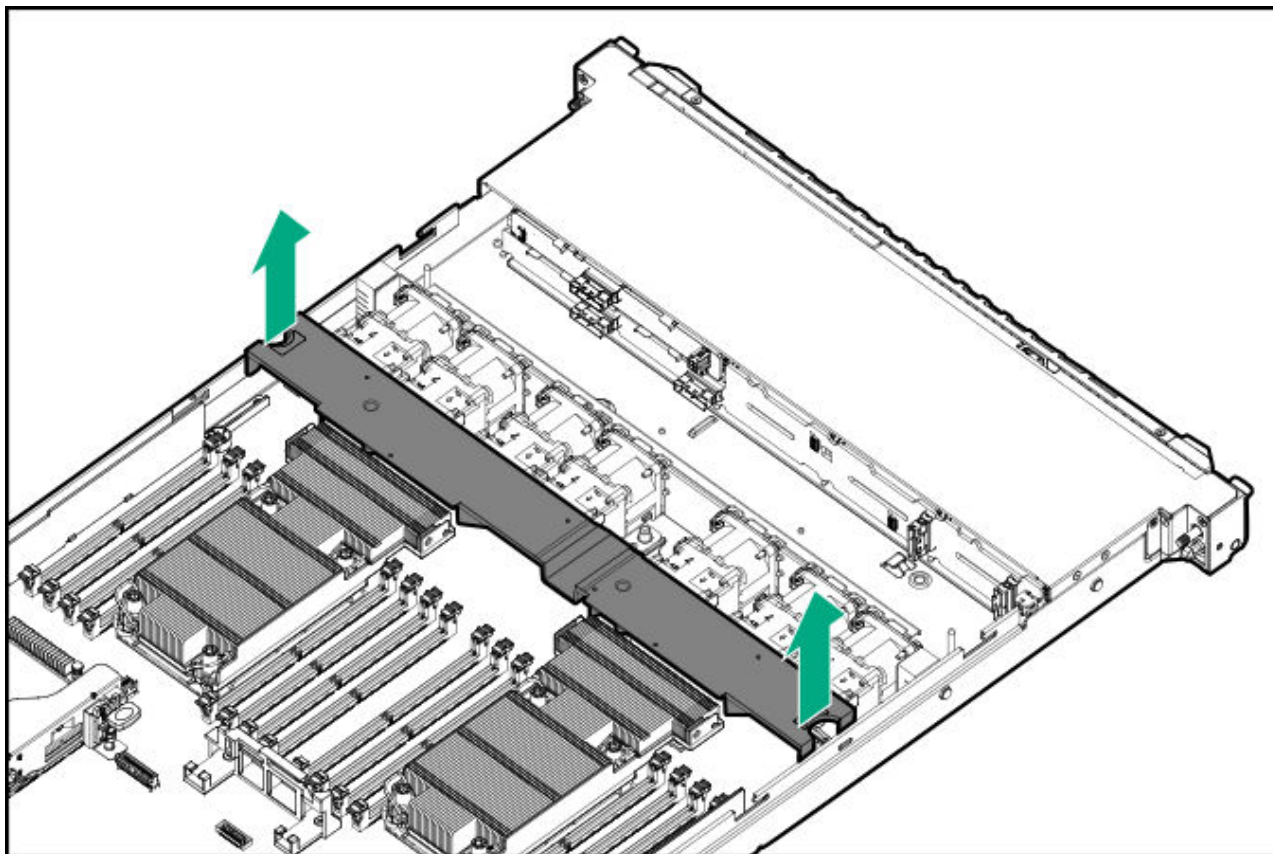

9.



CAUTION

Heatsink screws must be tightened and loosened in alternating sequence. Do not overtighten the screws as this might damage the system board or the processor socket.

Use a T-30 Torx screwdriver to loosen one pair of diagonally opposite heatsink screws (callouts 1 and 2), and then loosen the other pair of heatsink screws (callouts 3 and 4).

- Standard heatsink

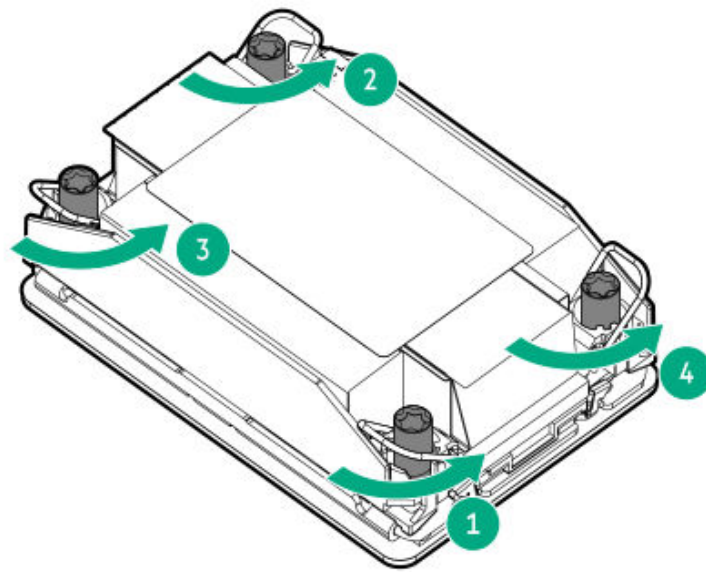

- High performance heatsink

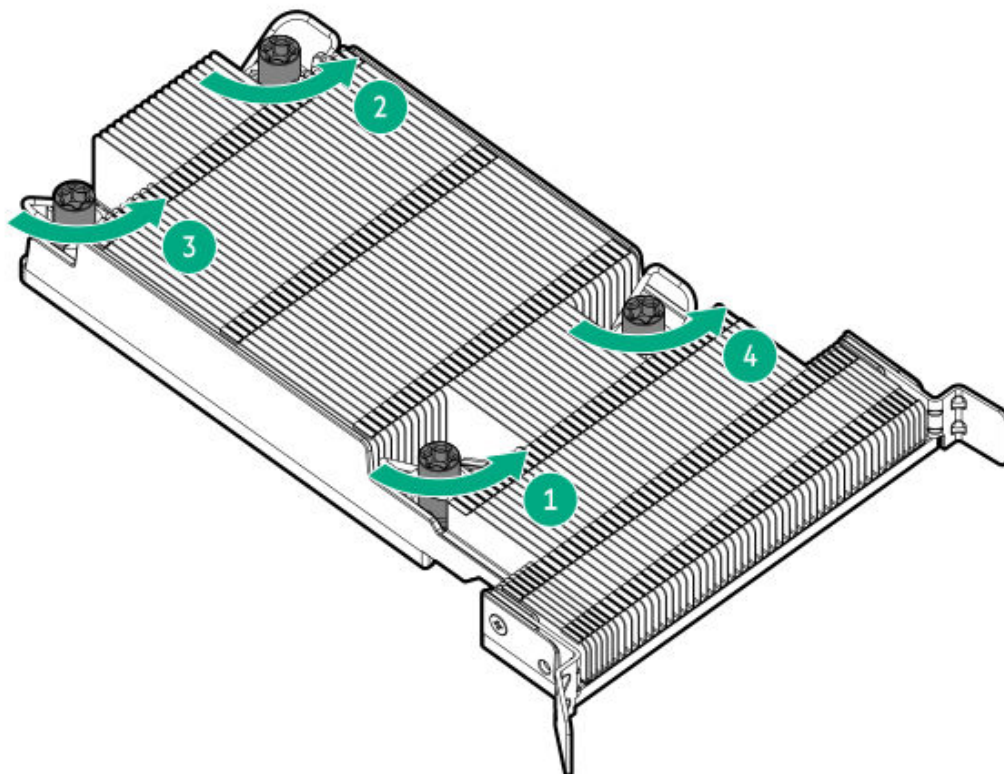

.0. Set the anti-tilt wires to the unlocked position.

- Standard heatsink



- High performance heatsink

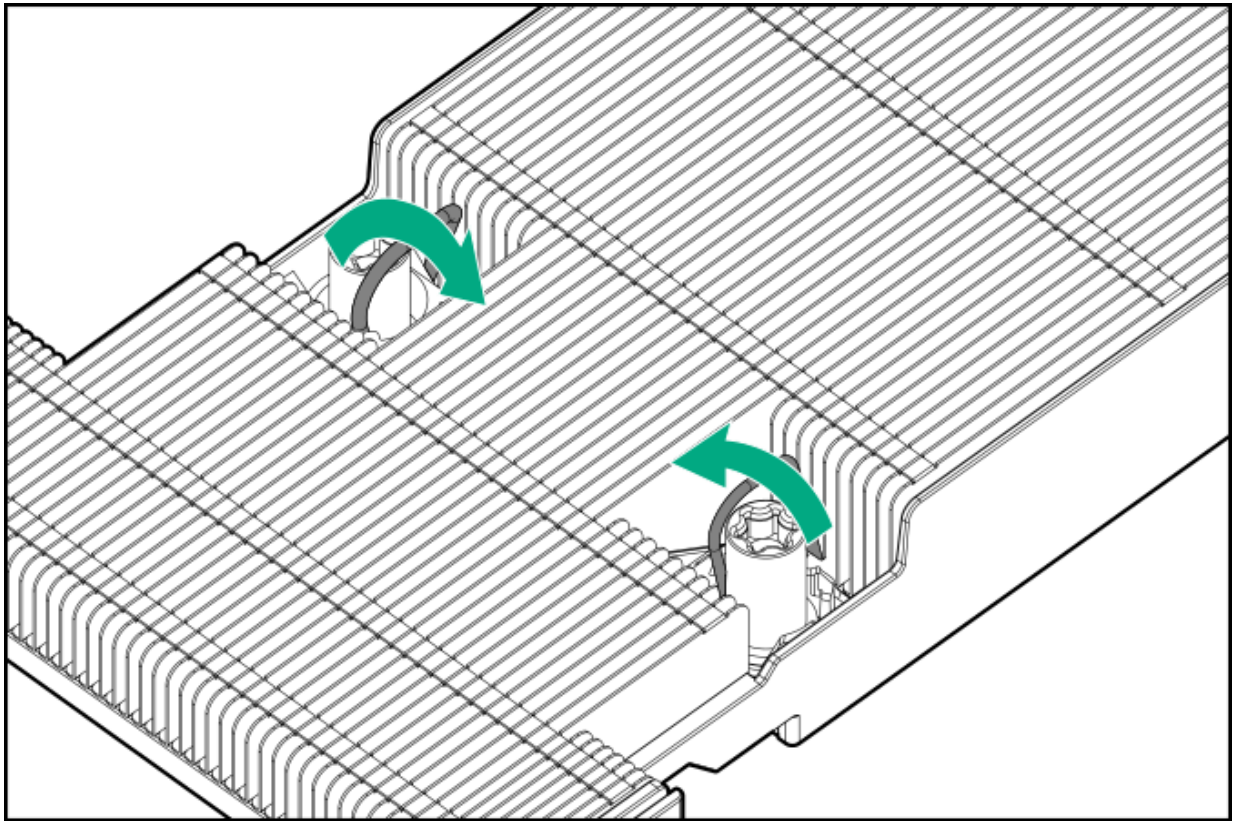

1.



CAUTION

To prevent mechanical damage or depositing oil on your hands or other contaminants to the heatsink contact surface, hold the heatsink only by the edge of its base plate. Do not touch the heatsink fins.

Lift the processor-heatsink module straight up from the system board.

- Standard heatsink



- High performance heatsink

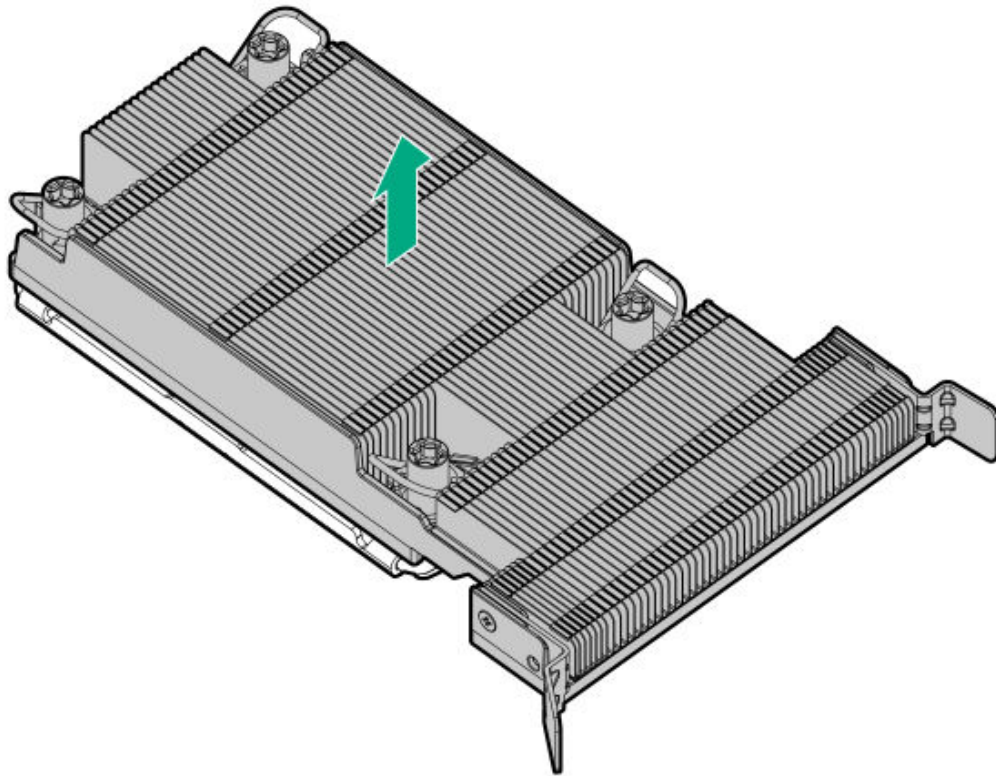

- .2. Place the processor-heatsink module on a flat work surface with its contact side facing up.
- .3. If you are not immediately installing the replacement processor-heatsink module, install the dust cover on the empty processor socket:



CAUTION

Do not press down on the dust cover. Pressing down on the dust cover might damage the processor socket.

- a. Press and hold the grip tabs on the dust cover.
- b. Carefully lower the dust cover onto the bolster plate guide posts.

Make sure that the corner holes of the dust cover are properly engaged with the guide posts on the bolster plate.

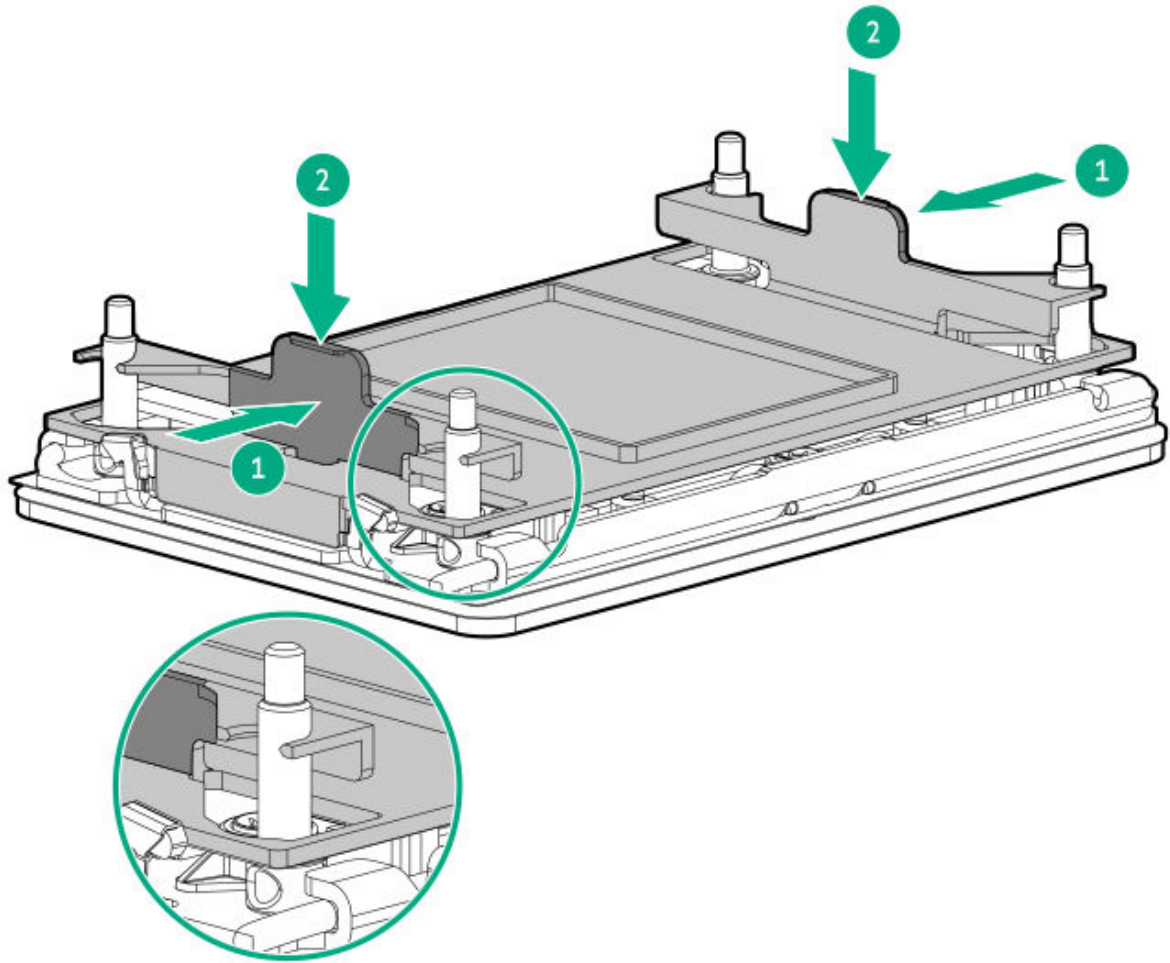

4. Do not touch the pins on the processor socket and the processor.



CAUTION

THE PINS ON THE PROCESSOR SOCKET AND ON THE PROCESSOR ARE VERY FRAGILE AND EASILY DAMAGED. Any damage to them might require replacing the system board.

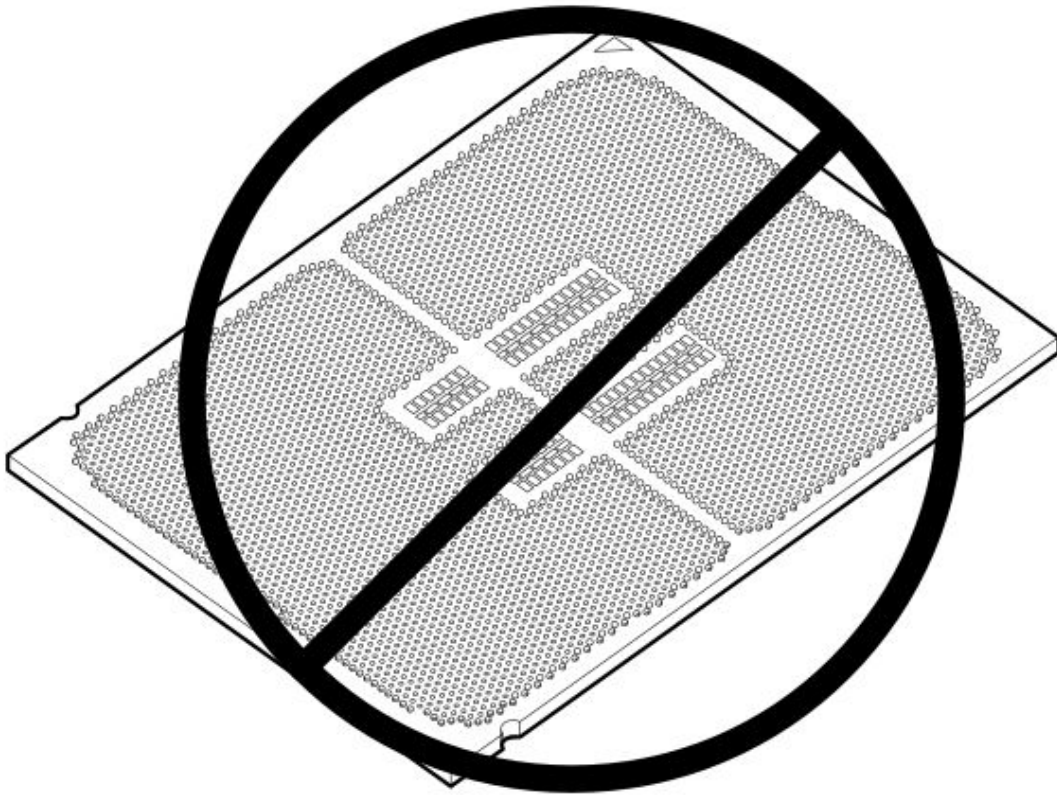
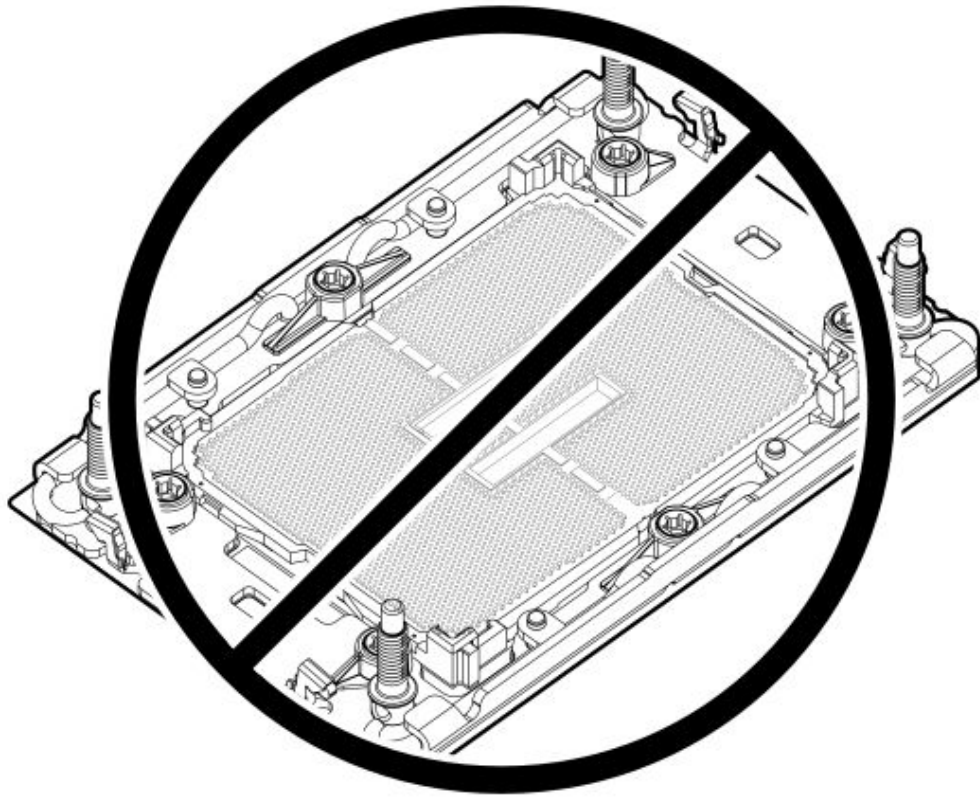

.5. Remove the processor from the heatsink:

a. Open the TIM breaker lever.

This action breaks the adhesion between the processor and the heatsink.

b. Hold the processor by its edges, and then remove it from the carrier.

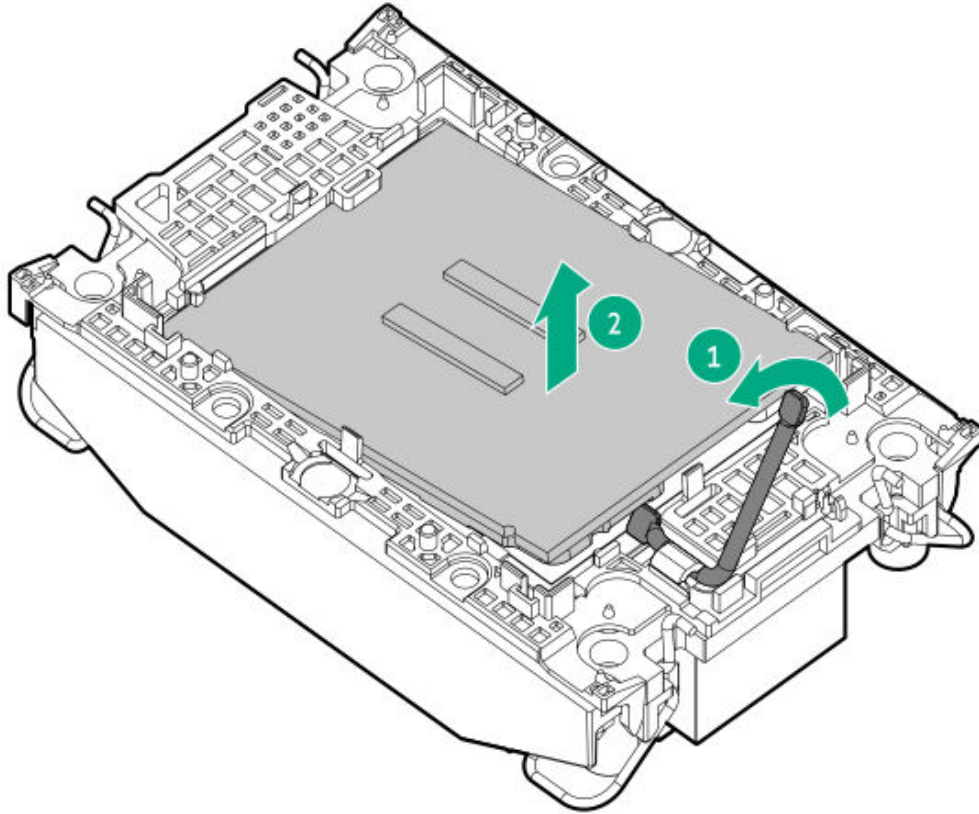

c. Starting from the pin 1 corner and moving in an opposite manner, disengage the processor carrier release tabs from the heatsink.

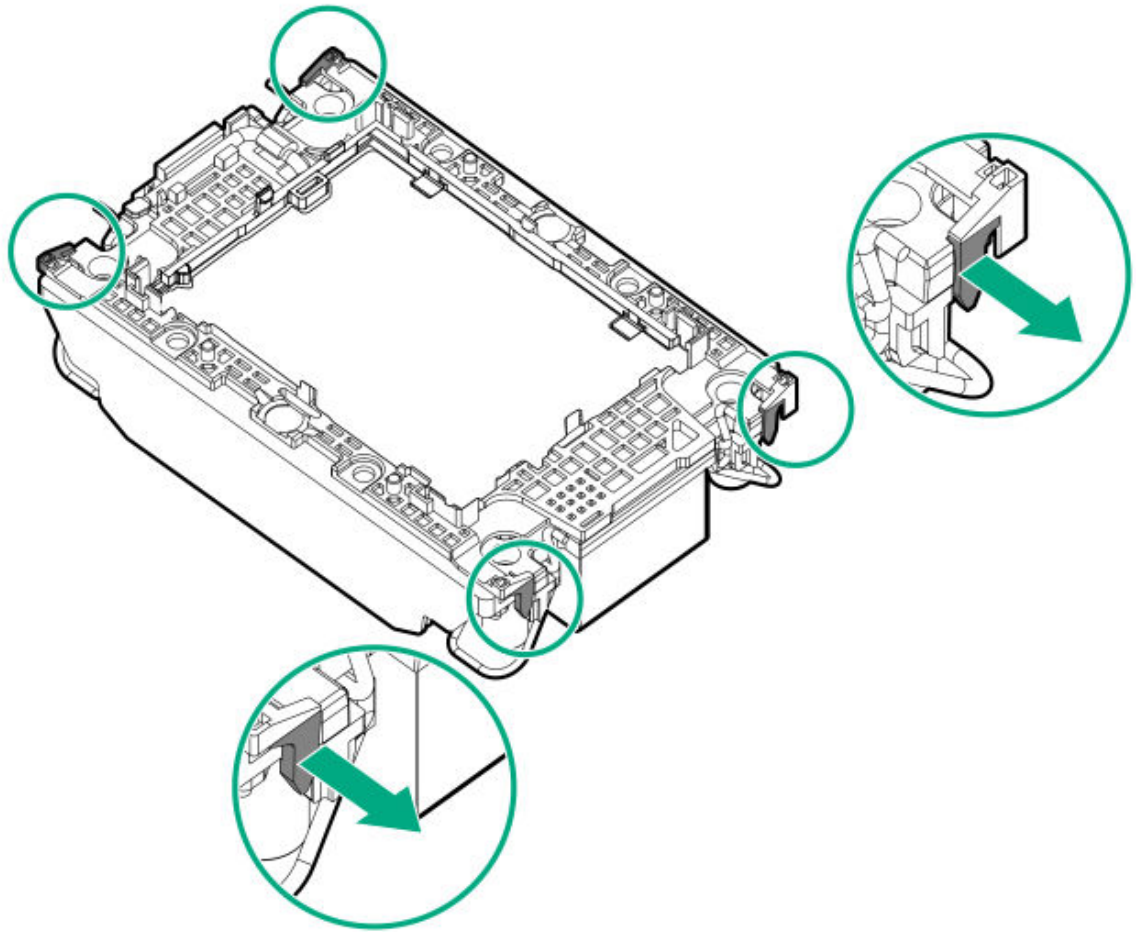

d. Lift the processor carrier away from the heatsink.

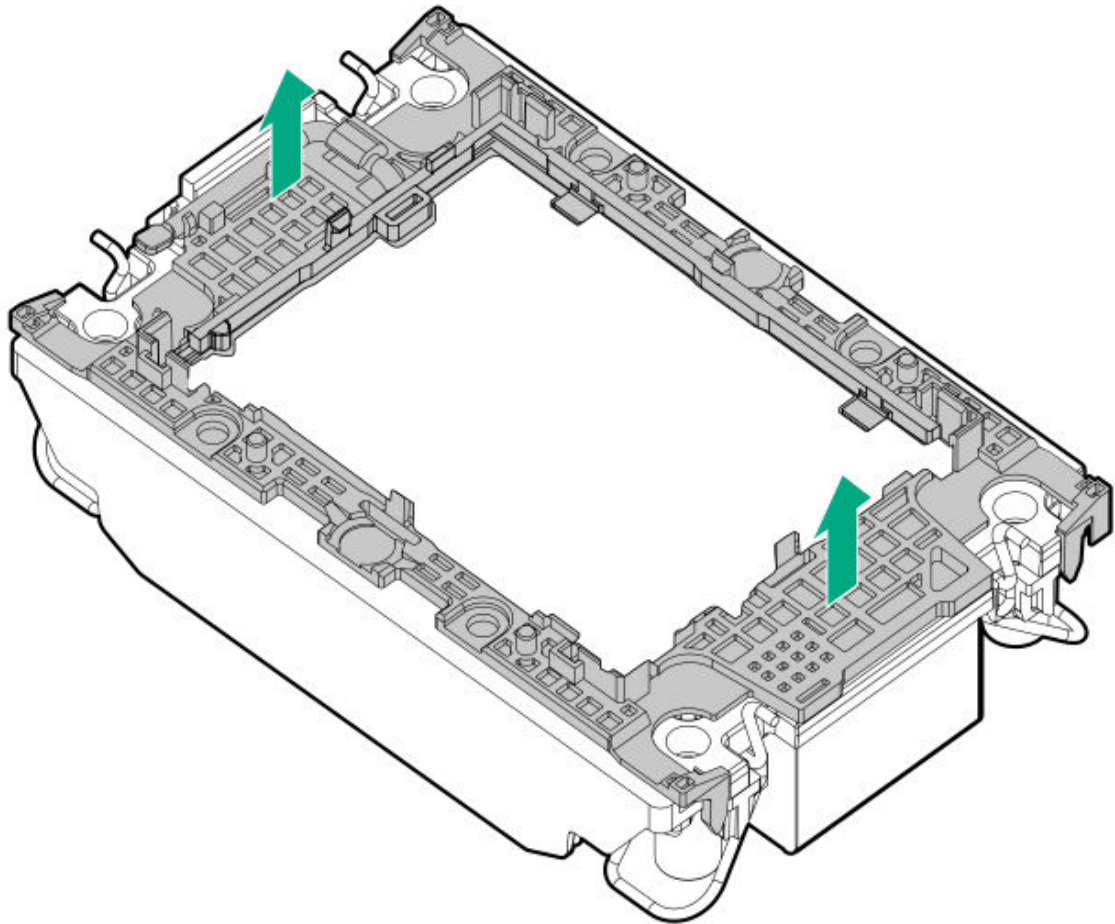

- .6. Using a cleaning solvent, such as alcohol wipes, remove the existing thermal grease from the processor and heatsink.

Allow the alcohol to evaporate before continuing.

Installing a processor

Prerequisites

- Review the following:
 - [Heatsink and processor socket components](#)
 - [Processor cautions](#)
 - [Fan and heatsink requirements](#)
- Before you perform this procedure, make sure that you have the following items available:

- T-30 Torx screwdriver or a bit driver with T-30 Torx bit
- Liquid cooling module handle—This is needed only if the system has a liquid cooling module installed. Use this handle to facilitate the removal and installation of the liquid cooling module when replacing the processor, system board, or liquid cooling module.

The handle can be ordered as a spare (P89110-001).

About this task



CAUTION

A discharge of static electricity from a finger or other conductor might damage system boards or other static-sensitive devices. To prevent damage, observe antistatic precautions.

Procedure

1. Do not touch the pins on the processor socket and the processor.



CAUTION

THE PINS ON THE PROCESSOR SOCKET AND ON THE PROCESSOR ARE VERY FRAGILE AND EASILY DAMAGED. Any damage to them might require replacing the system board.

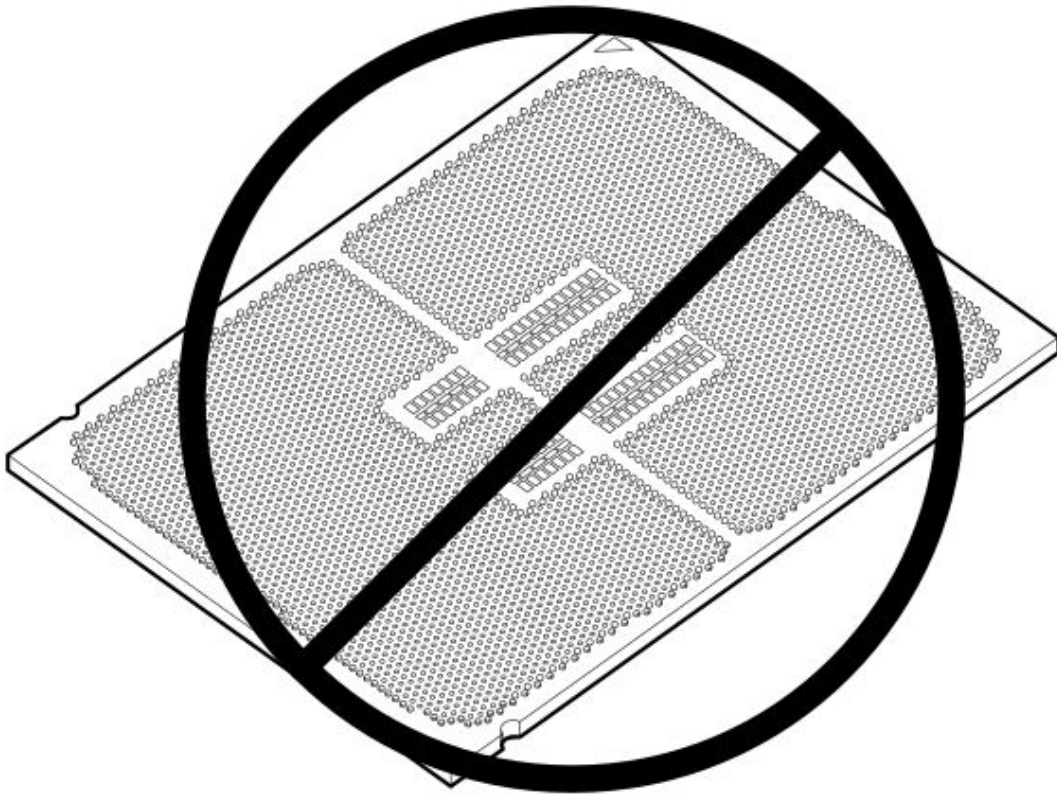
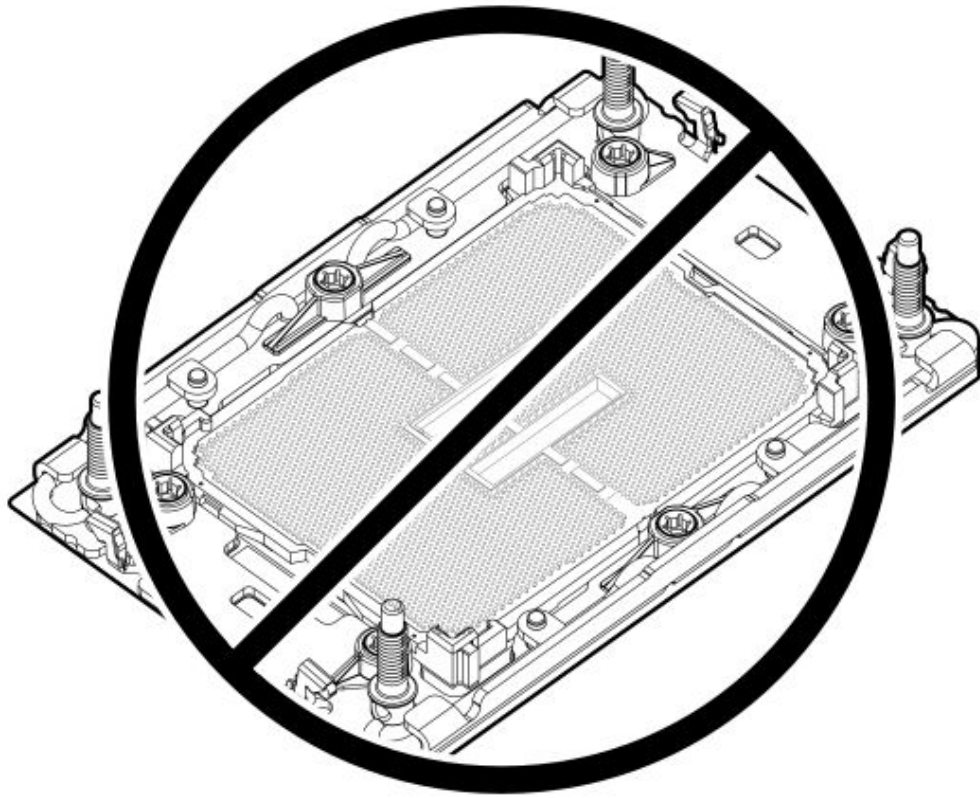

2. If the system uses standard or high performance heatsinks, proceed to step 3.

If the system uses liquid cooling, install the processor carrier on the cold plate and then install the liquid cooling module. After completing these steps, proceed to step 12.

3. If you are using the same heatsink, apply the full content of the thermal grease syringes on top of the processor. Follow the pattern shown in the following image.

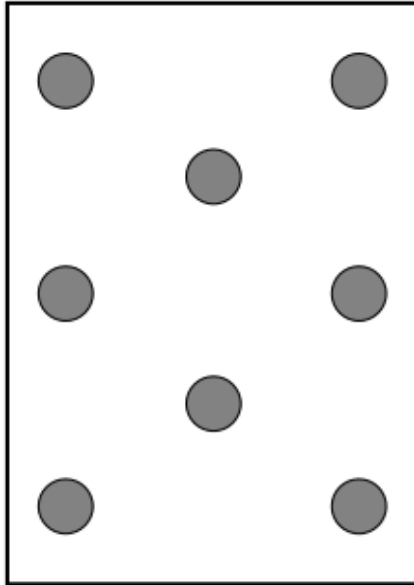

4. If you are using a new heatsink, remove the protective film from the thermal interface material.
 - Standard heatsink

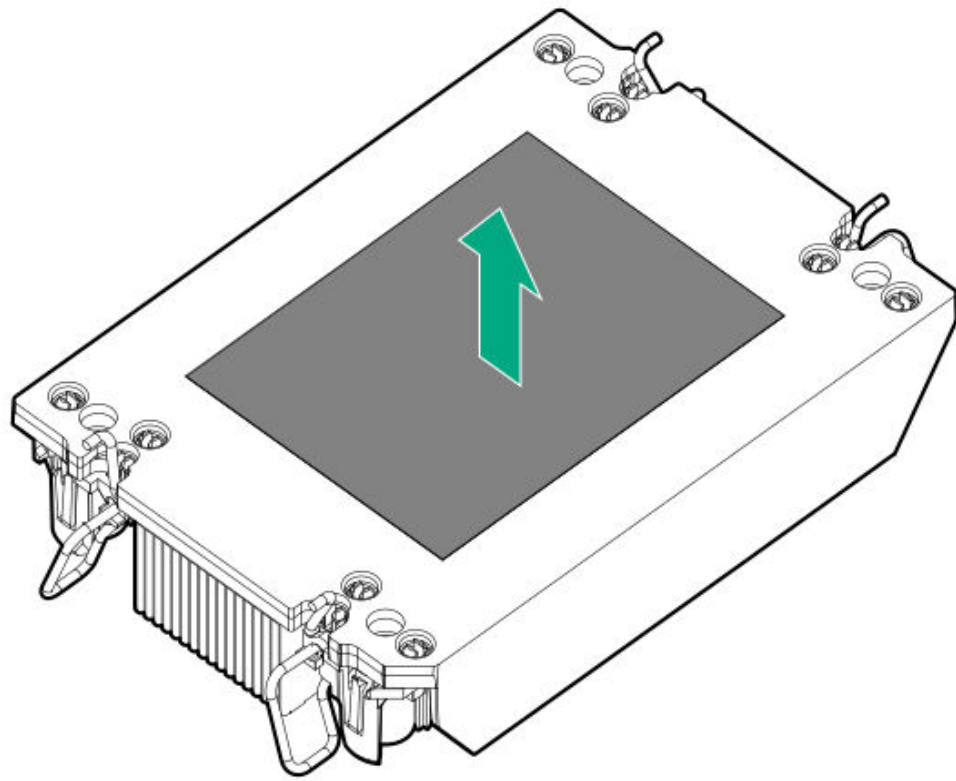

- High performance heatsink

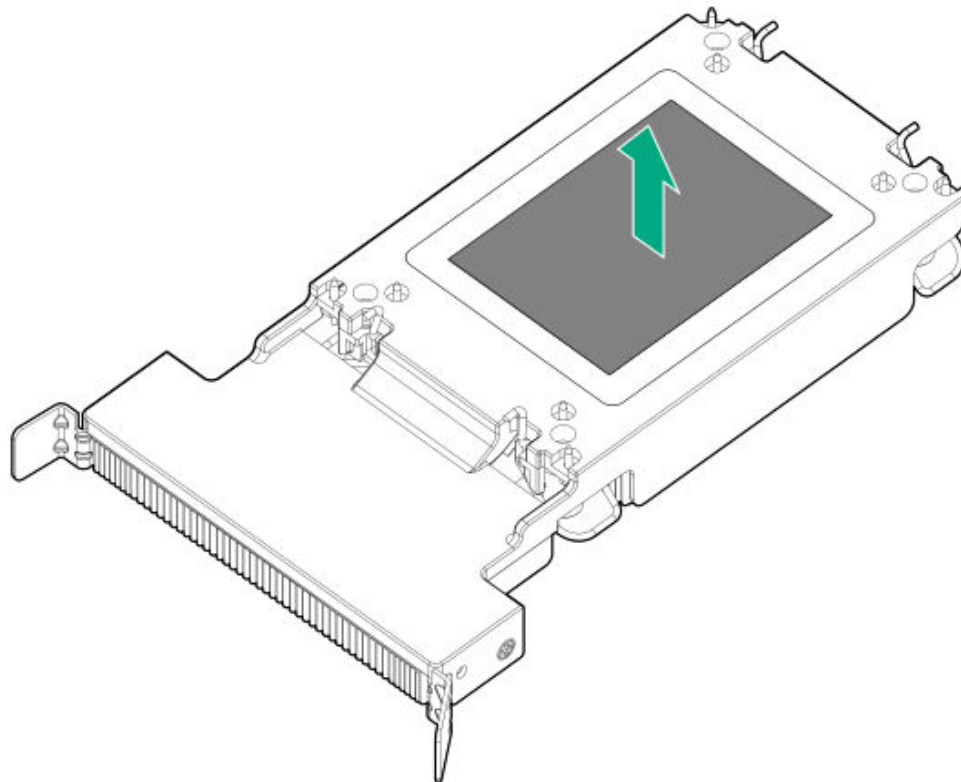

5. Set the anti-tilt wires to the locked position.



6. Verify that the processor is securely latched to the processor carrier.

The following illustration calls out the keying feature tabs that secure the processor. Different processor carriers will have these tabs in different locations.

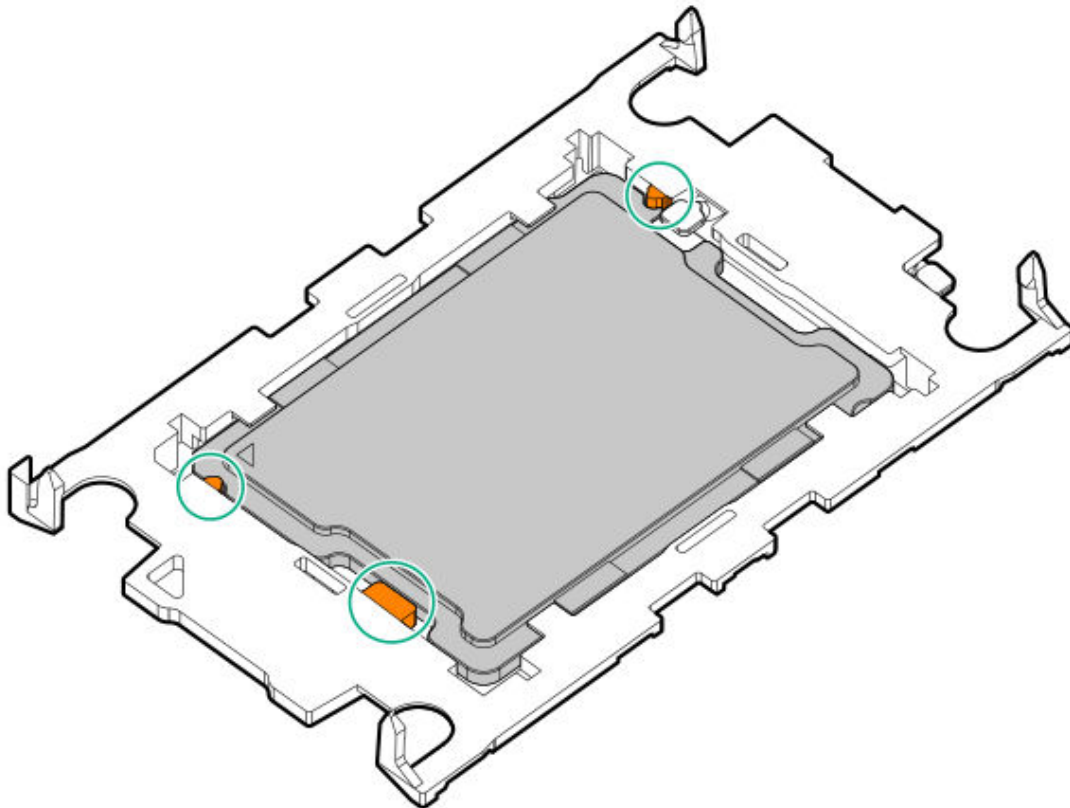

7. Attach the heatsink to the processor carrier:
 - a. Align the pin 1 indicator on the processor carrier with that on the heatsink.
 - Standard heatsink

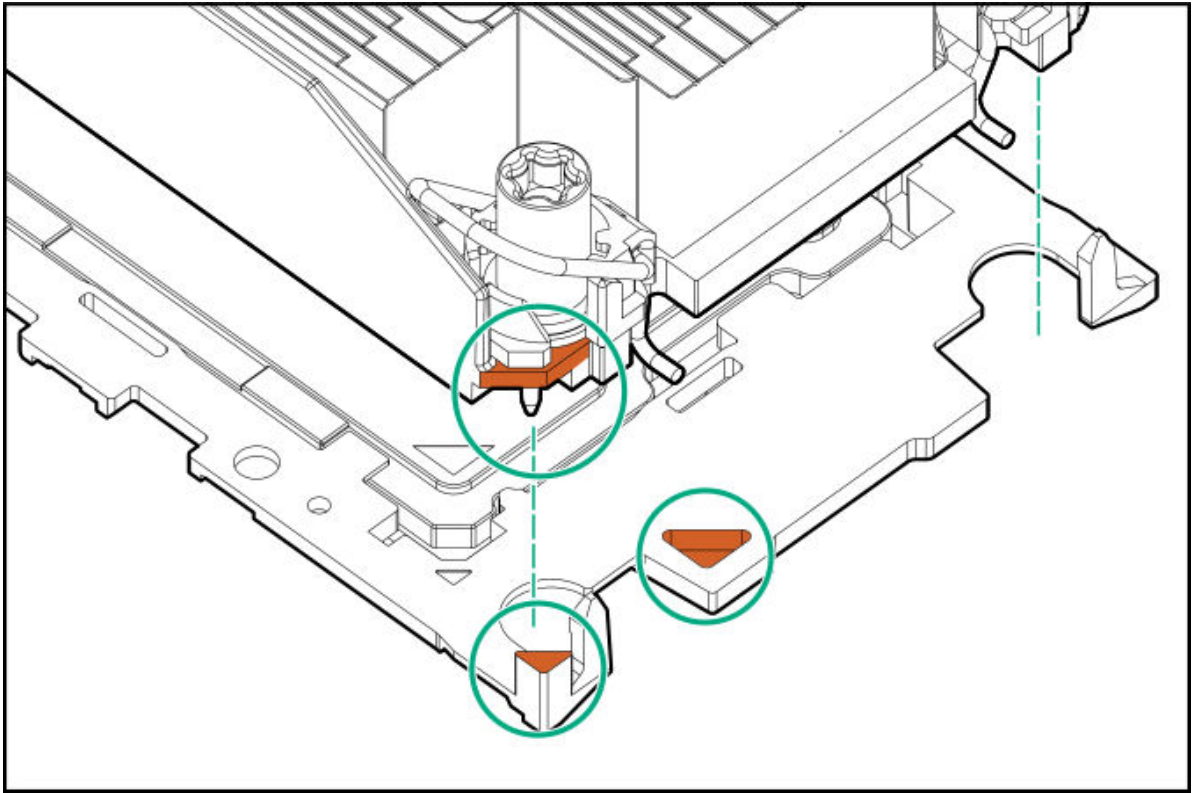

- High performance heatsink

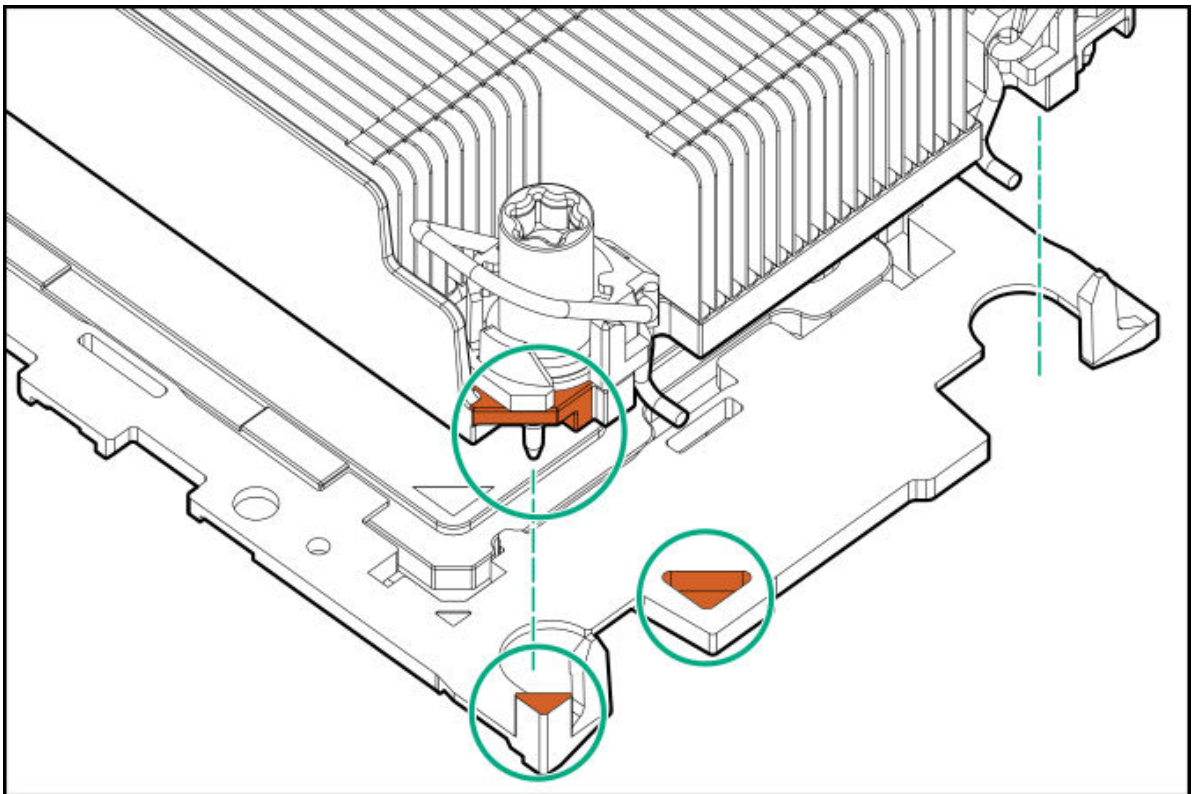

b. Lower the heatsink on the processor carrier until the carrier tabs snap into place.

There will be an audible click to indicate that the heatsink is properly latched on the processor carrier.

- Standard heatsink

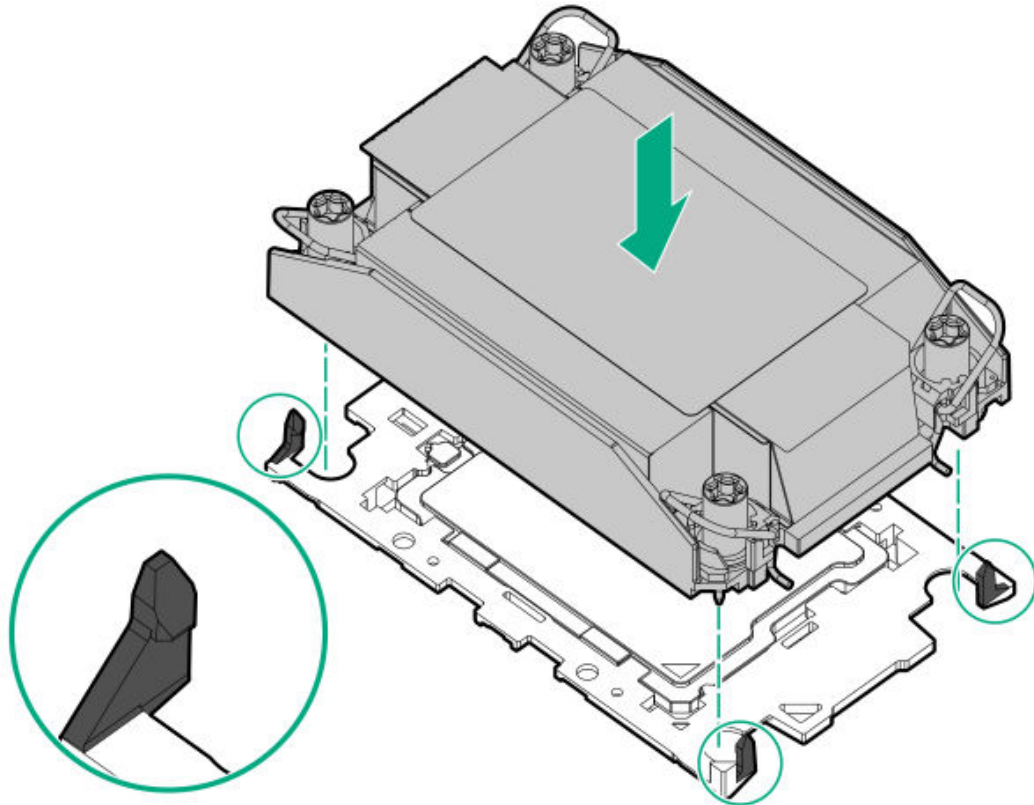

- High performance heatsink

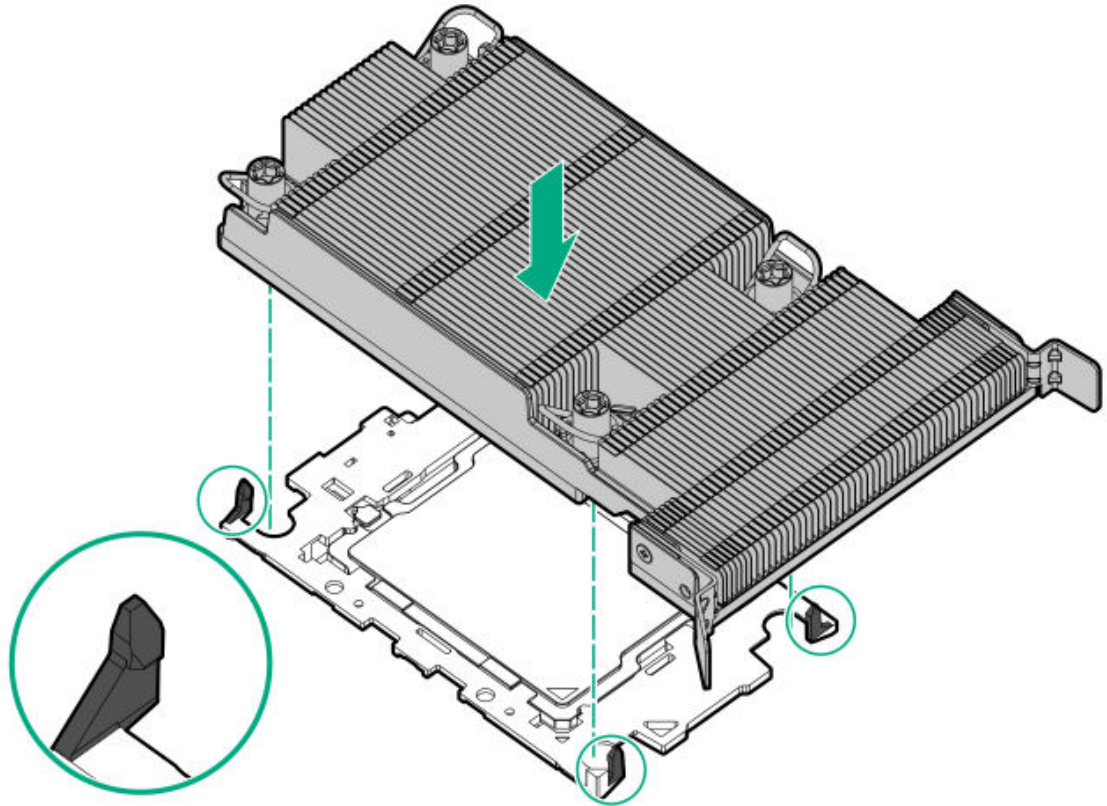

8. Perform the following verification steps:

a. Verify that the tabs on the processor carrier are securely latched on the heatsink.

- Standard heatsink

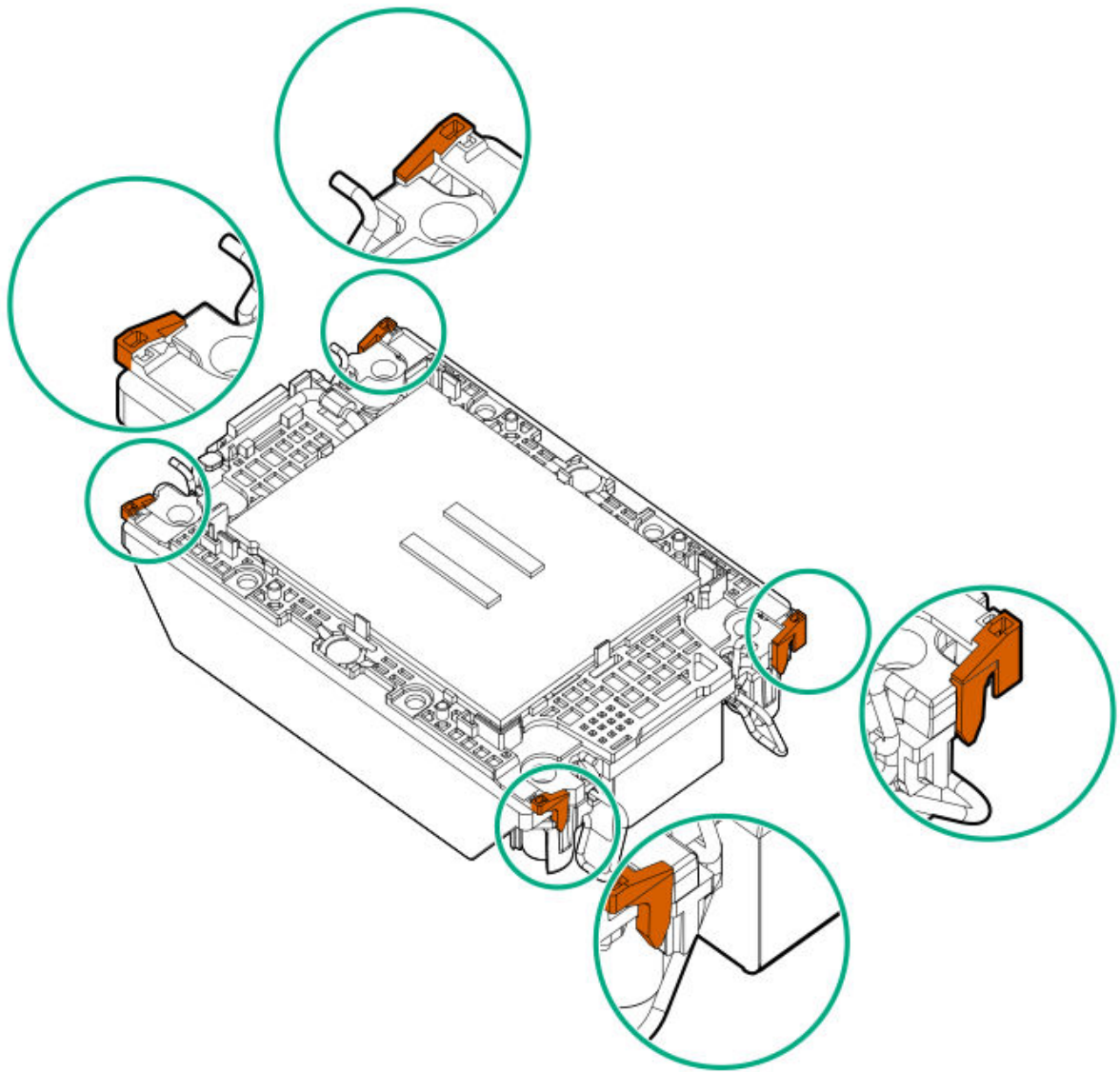

- High performance heatsink

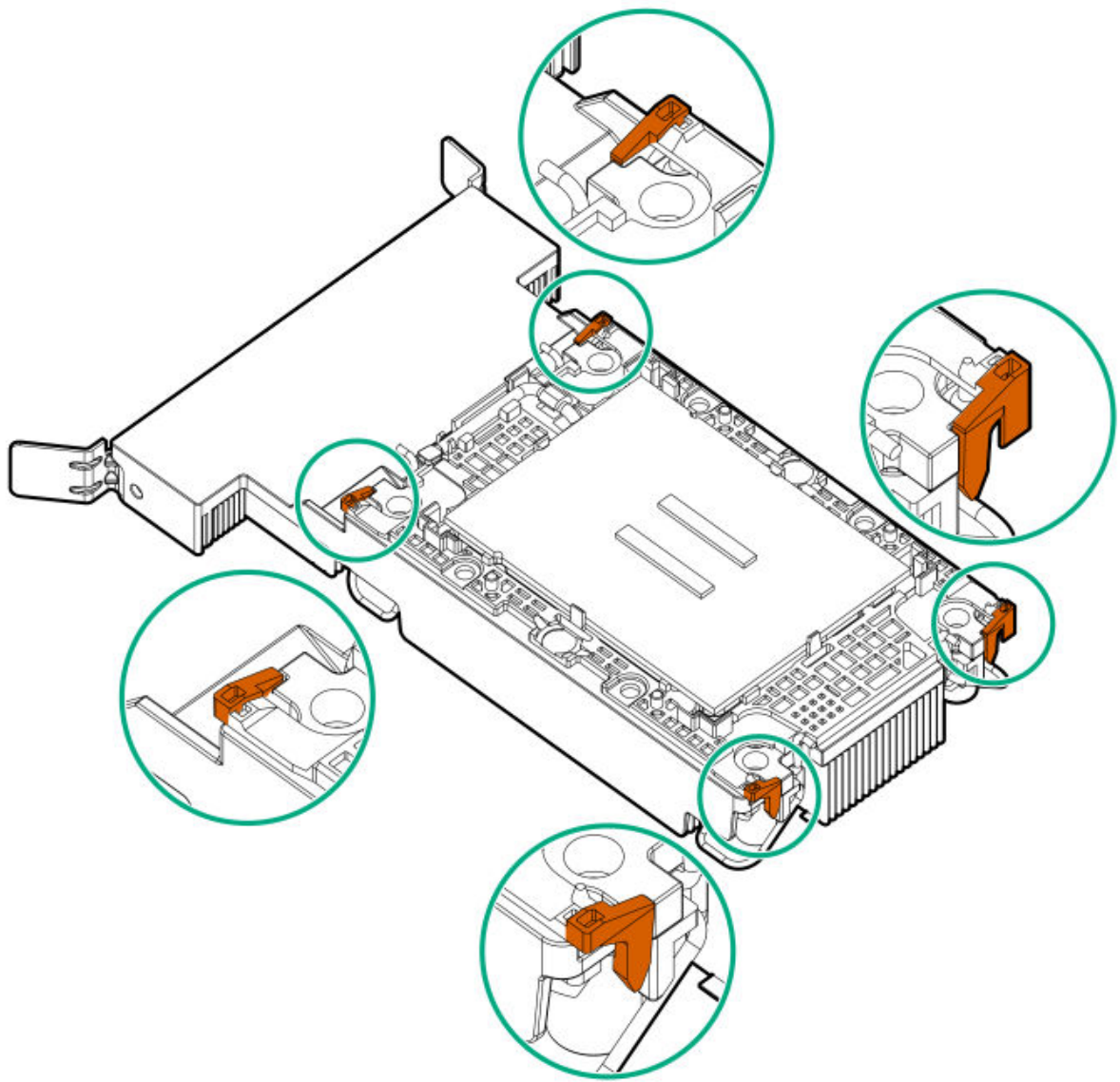

b. Verify that the pin 1 indicators on the processor and processor carrier are aligned.

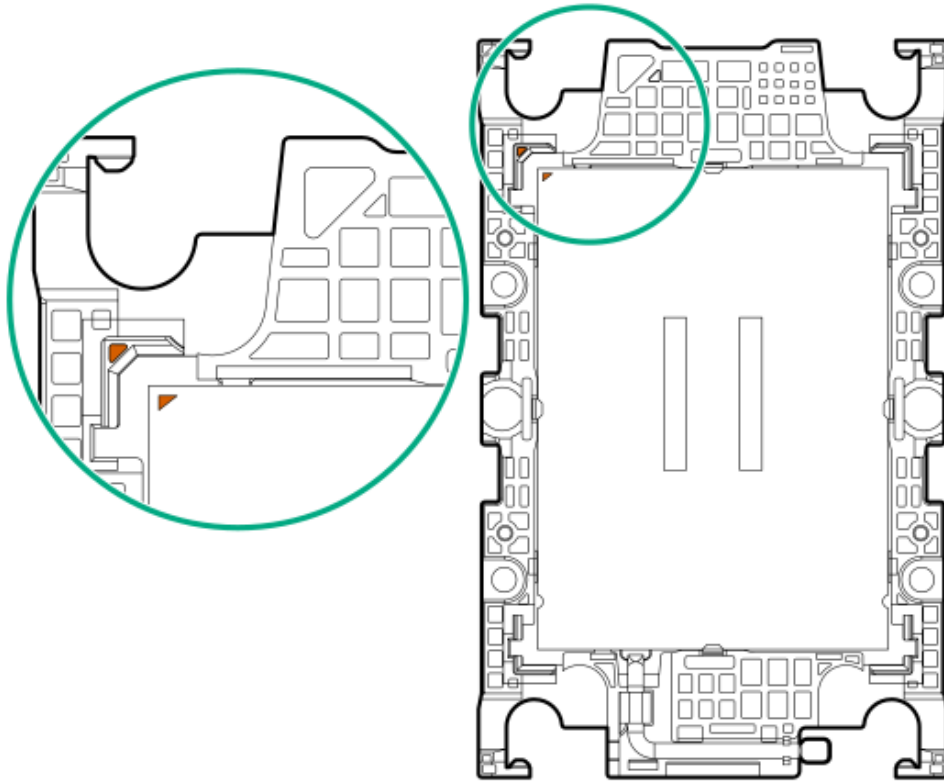

c. Verify that the processor is properly secured by the carrier snaps.

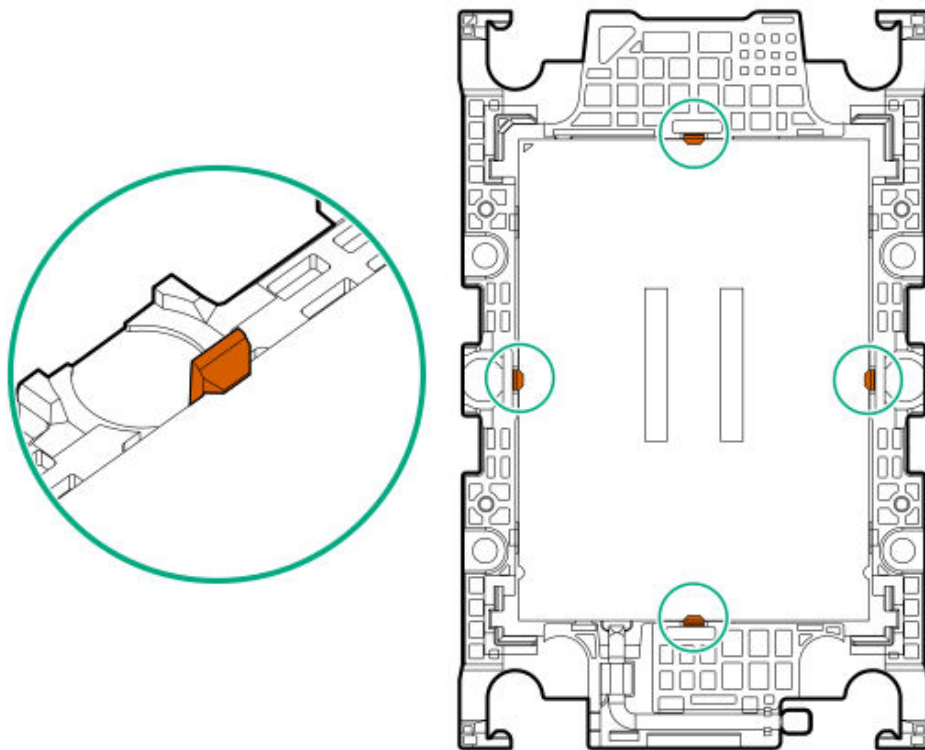

9. Set the anti-tilt wires to the unlocked position.

- Standard heatsink



- High performance heatsink

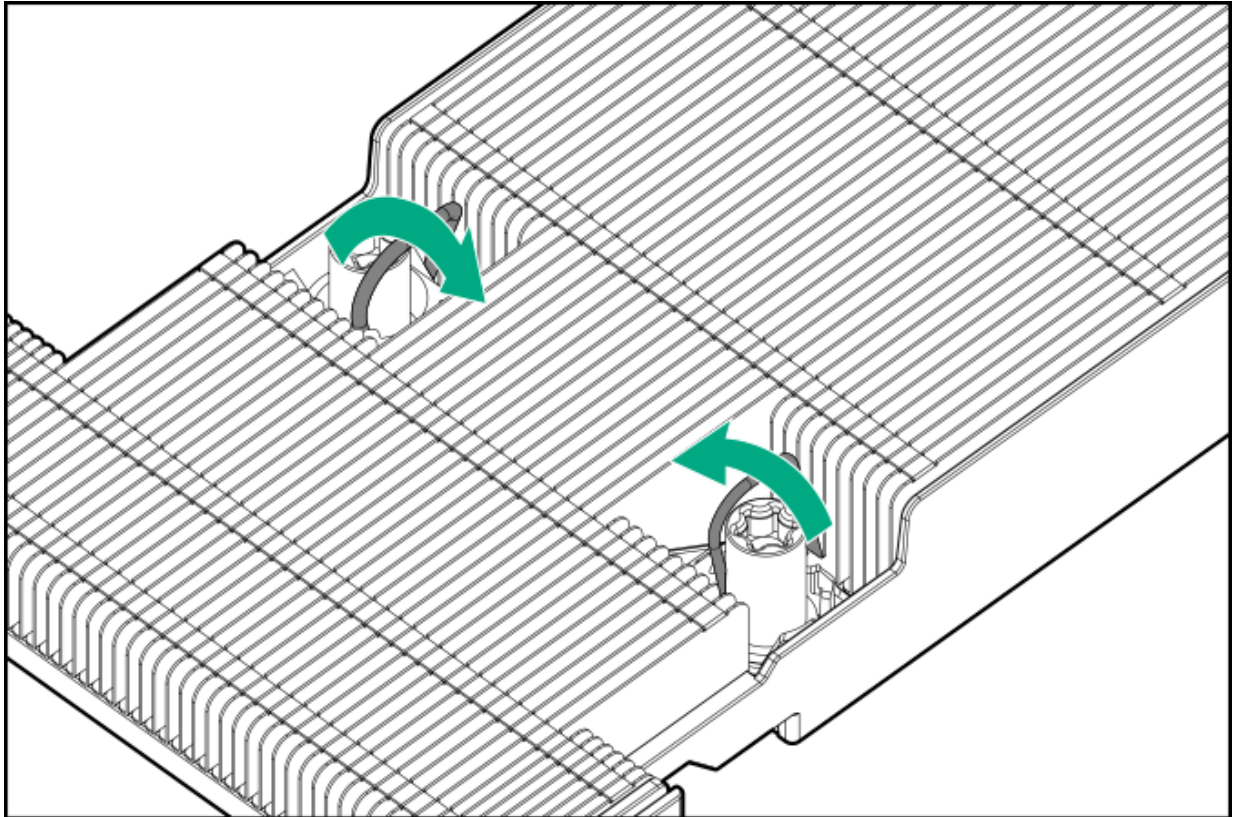

10.



CAUTION

To prevent thermal failure or component damage, do not move the heatsink once the bottom of its base plate touches the top of the processor. Excessive heatsink movement can cause the thermal grease to smear and become uneven. Voids in the compound can adversely impact the transfer of heat away from the processor.

Install the processor-heatsink module:

- a. When using a torque wrench to tighten the heatsink screws, set 0.9 N-m (8 in-lb) of torque.
- b. Note the **Front of server** text on the heatsink label to correctly orient the processor-heatsink module over the bolster plate.

c. Carefully lower the processor-heatsink module onto the bolster plate guide posts.

The posts are keyed so that the module can only be installed one way. Make sure that the module is properly seated on the bolster plate before securing the screws.

- Standard heatsink

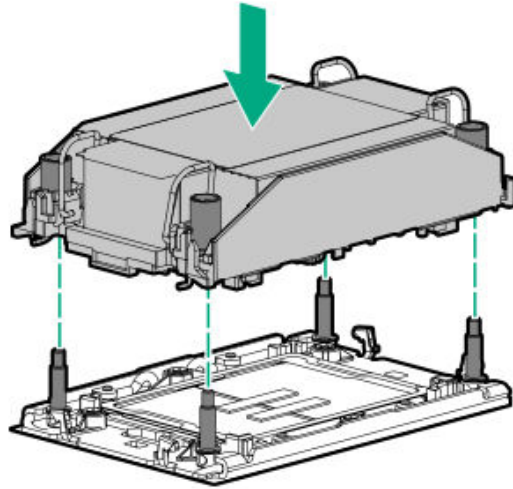

- High performance heatsink

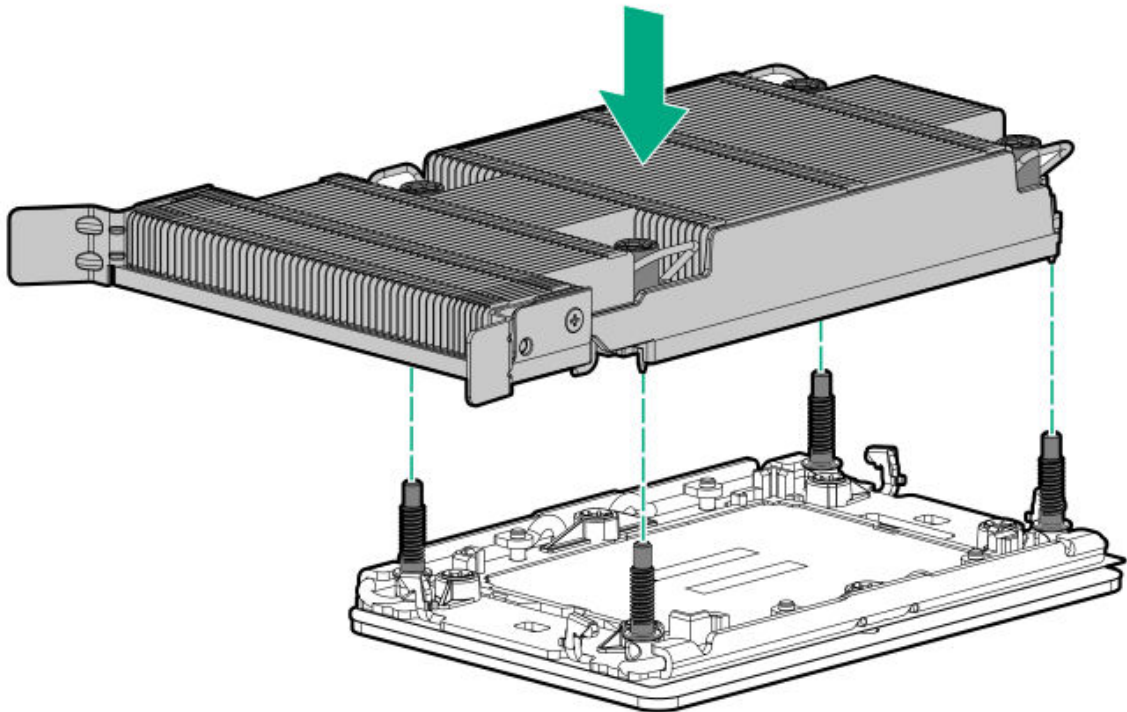

d. Set the anti-tilt wires to the locked position.



e. Tighten one pair of diagonally opposite heatsink screws, and then tighten the other pair of heatsink screws.

- Standard heatsink

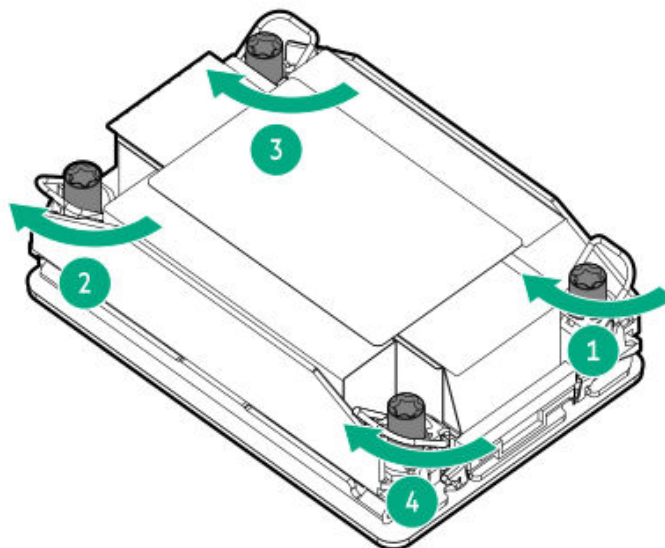

- High performance heatsink

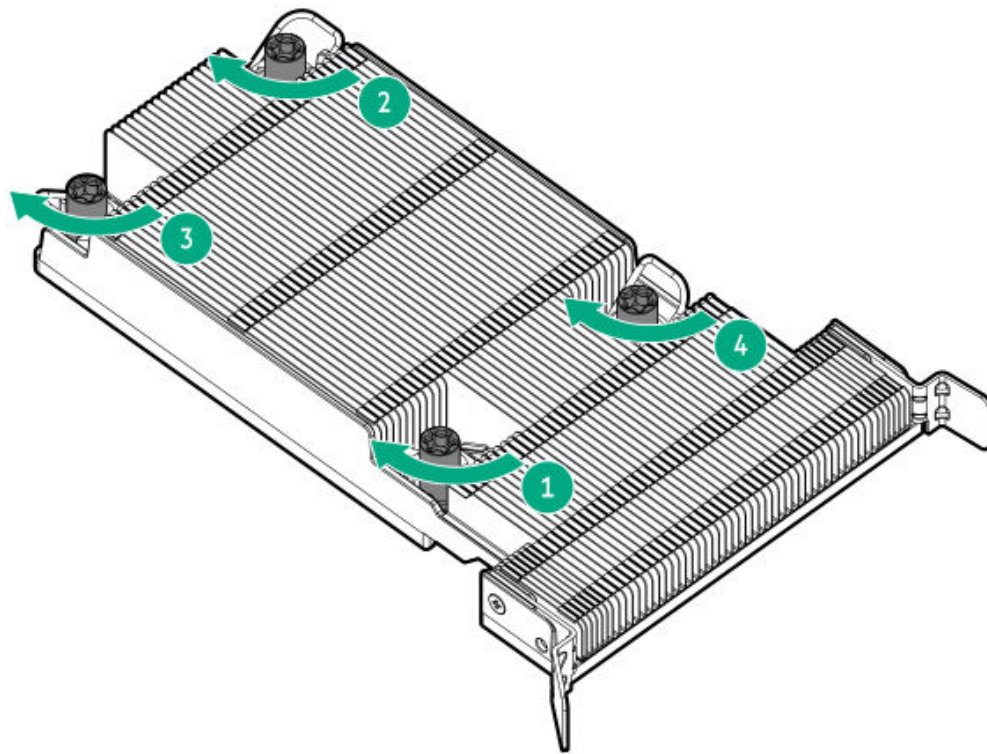

.1. (Optional) Install the air baffle.

The air baffle is supported only when the system is configured with high performance heatsinks.

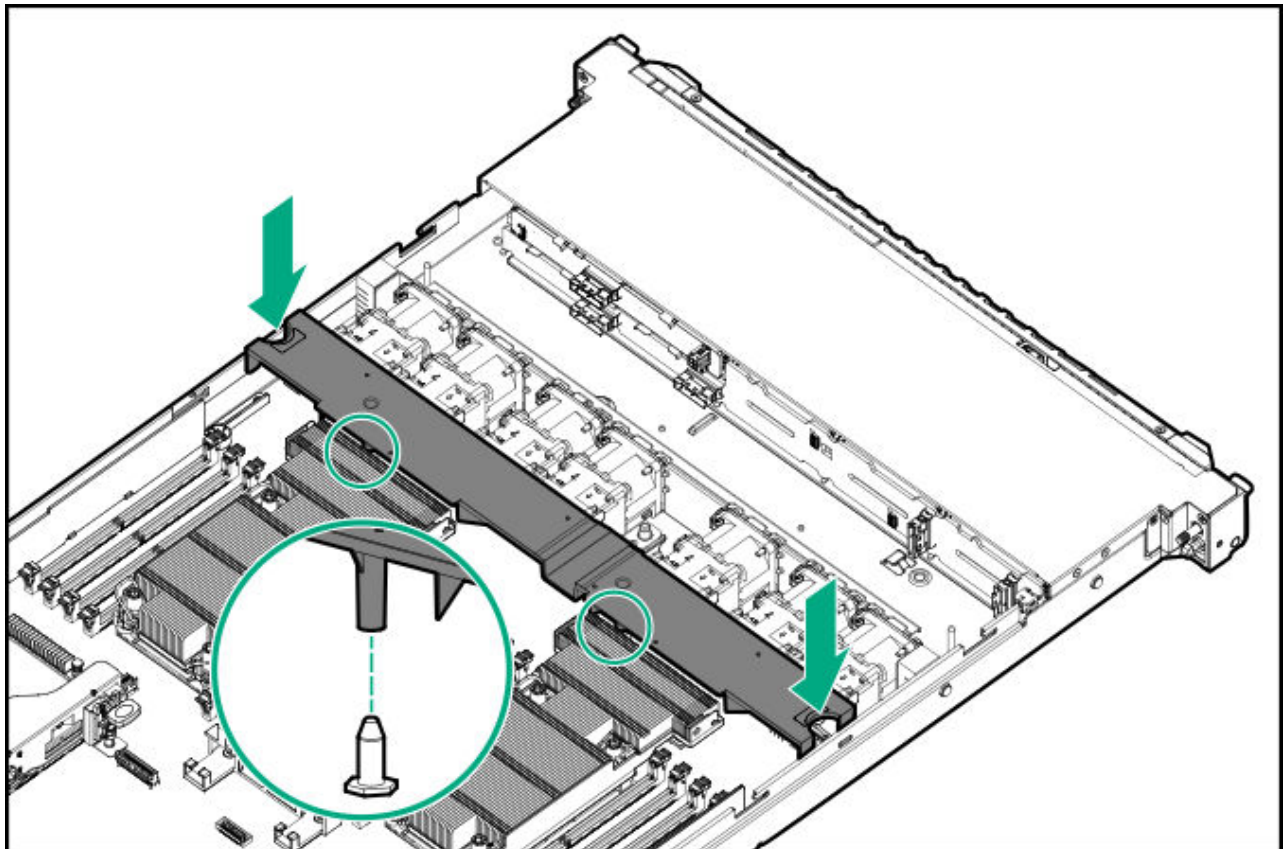

- .2. Install the access panel.
- .3. If the server was removed from an enclosure or a rack, reinstall it now.
- .4. If the system uses direct liquid cooling, connect the DLC kit to the rack manifold.
- .5. Connect all peripheral cables to the server.
- .6. Connect each power cord to the server.
- .7. Connect each power cord to the power source.
- .8. Power up the server.

Results

The replacement procedure is complete.

System board replacement

Subtopics

[Removing the system board assembly](#)

[Installing the system board assembly](#)

[Re-entering the server serial number and product ID](#)

Removing the system board assembly

Prerequisites



CAUTION

Be sure to have the BitLocker recovery key/password prior to replacing the system board. If you do not have the key/password, you will need to reinstall the OS.

- Perform a backup of critical server data.
- Before you perform this procedure, make sure that you have the following items available:
 - T-30 Torx screwdriver or a bit driver with T-30 Torx bit

- T-15 Torx screwdriver
- Liquid cooling module handle—This is needed only if the system has a liquid cooling module installed. Use this handle to facilitate the removal and installation of the liquid cooling module when replacing the processor, system board, or liquid cooling module.

The handle can be ordered as a spare (P89110-001).

About this task



WARNING

To reduce the risk of personal injury from hot surfaces, allow the internal system components to cool before touching them.



CAUTION

A discharge of static electricity from a finger or other conductor might damage system boards or other static-sensitive devices. To prevent damage, observe antistatic precautions.

Procedure

1. Power down the server.
2. Remove all power:
 - a. Disconnect each power cord from the power source.
 - b. Disconnect each power cord from the server.
3. Disconnect all peripheral cables from the server.
4. If the system uses direct liquid cooling, disconnect the DLC kit from the rack manifold.
5. If the server is installed in an enclosure or a rack, remove the server and place it on a flat, level work surface.
6. Remove all power supplies.
7. Remove the access panel.
8. If installed, remove the air baffle.

An 8 SFF server is shown. The removal procedure is the same for all drive configurations.

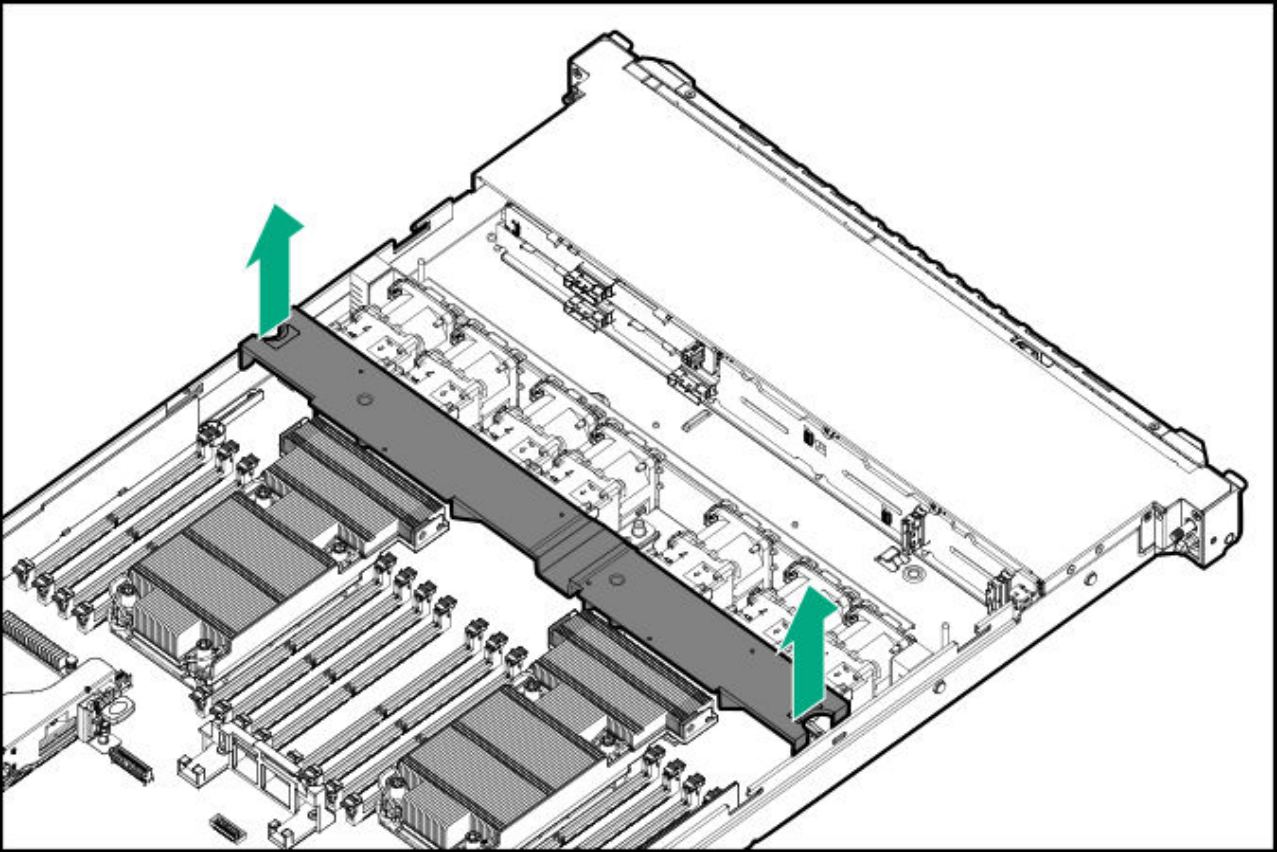

9. Take note of port numbers and cable connections to risers and the system board.
- .0. Disconnect and remove all cables that are connected to risers or the system board.
- .1. Remove all riser cages.
- .2. Remove the controller.
- .3. Remove all fans.

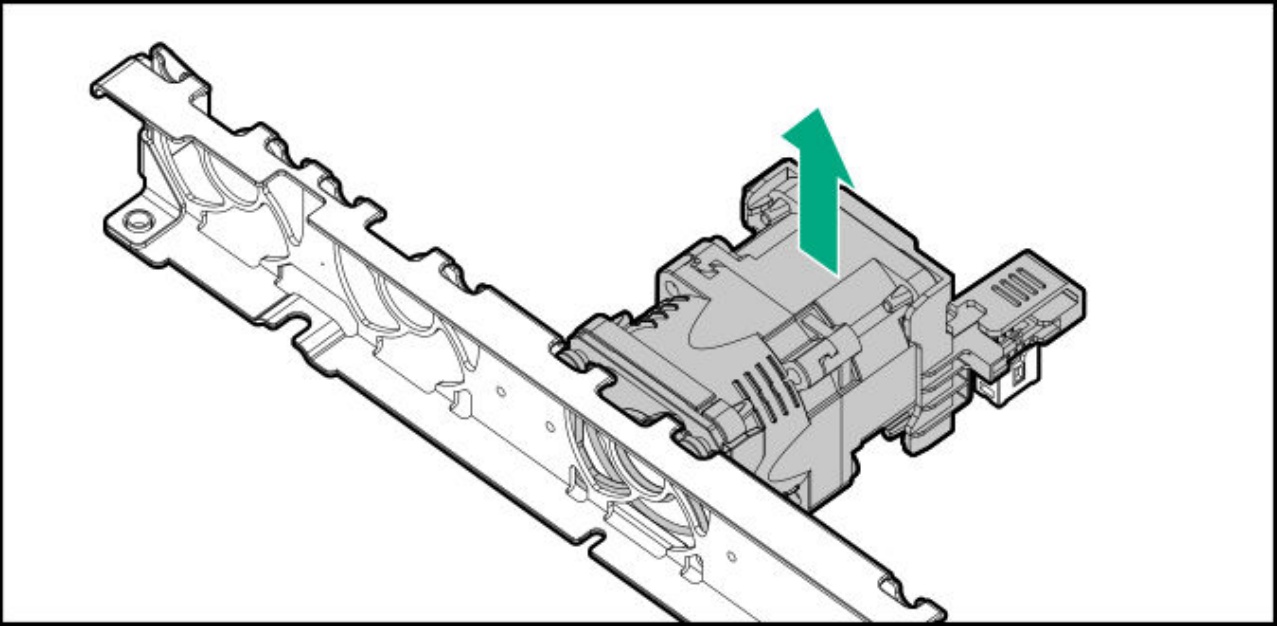

.4. Remove the OCP adapter.

.5. Remove all DIMMs.

Be sure to note the DIMM slot locations in which each DIMM is installed. These components must be installed in the same locations on the new system board.

.6. Remove all DIMM blanks.

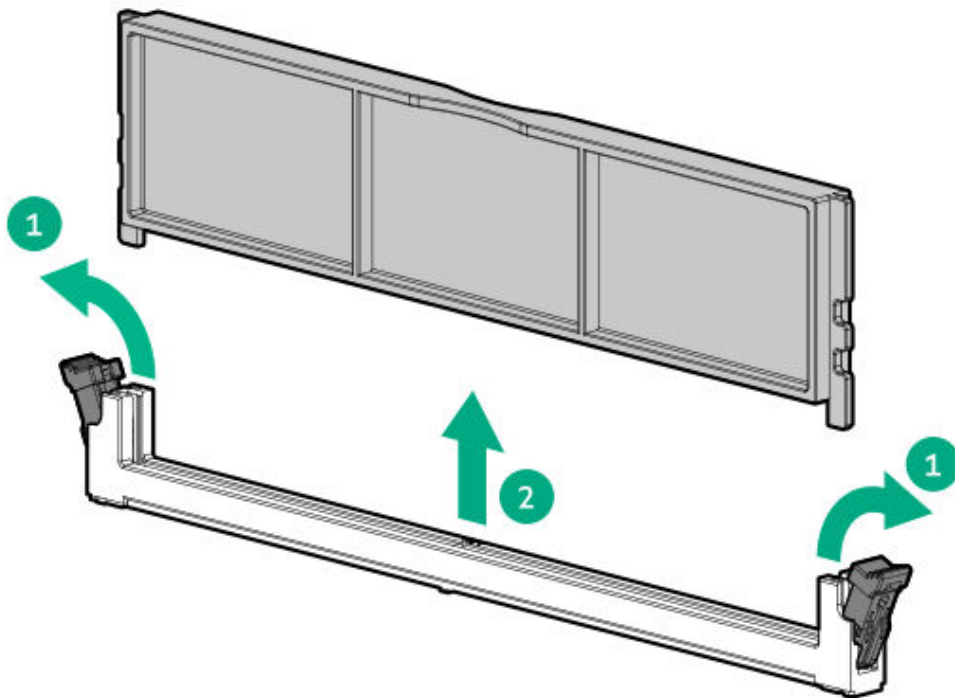

.7. If the system uses standard or high performance heatsinks, proceed to step [18](#).

If the system has a liquid cooling module installed, [remove the liquid cooling module](#) and then proceed to step [22](#) to remove the system board.

.8.



CAUTION

Heatsink screws must be tightened and loosened in alternating sequence. Do not overtighten the screws as this might damage the system board or the processor socket.

Use a T-30 Torx screwdriver to loosen one pair of diagonally opposite heatsink screws (callouts 1 and 2), and then loosen the other pair of heatsink screws (callouts 3 and 4).

- Standard heatsink

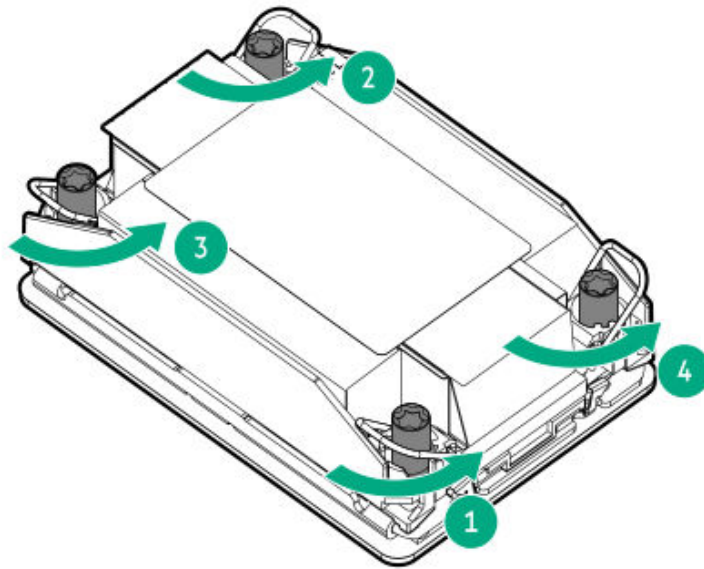

- High performance heatsink

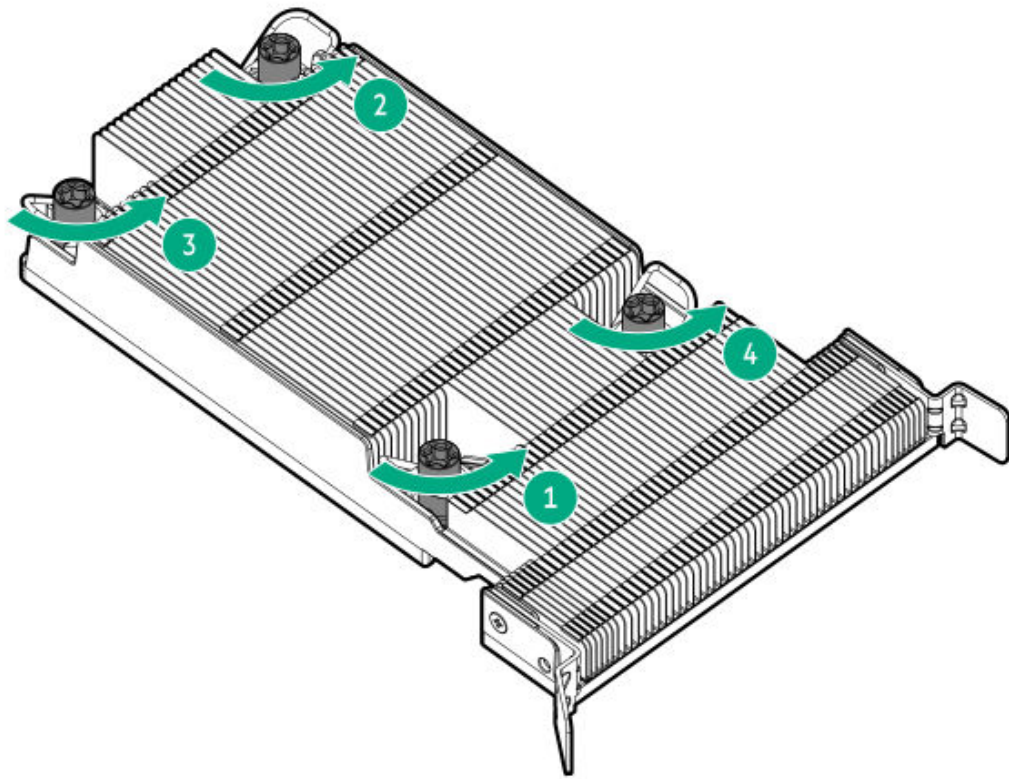

.9. Set the anti-tilt wires to the unlocked position.

- Standard heatsink



- High performance heatsink

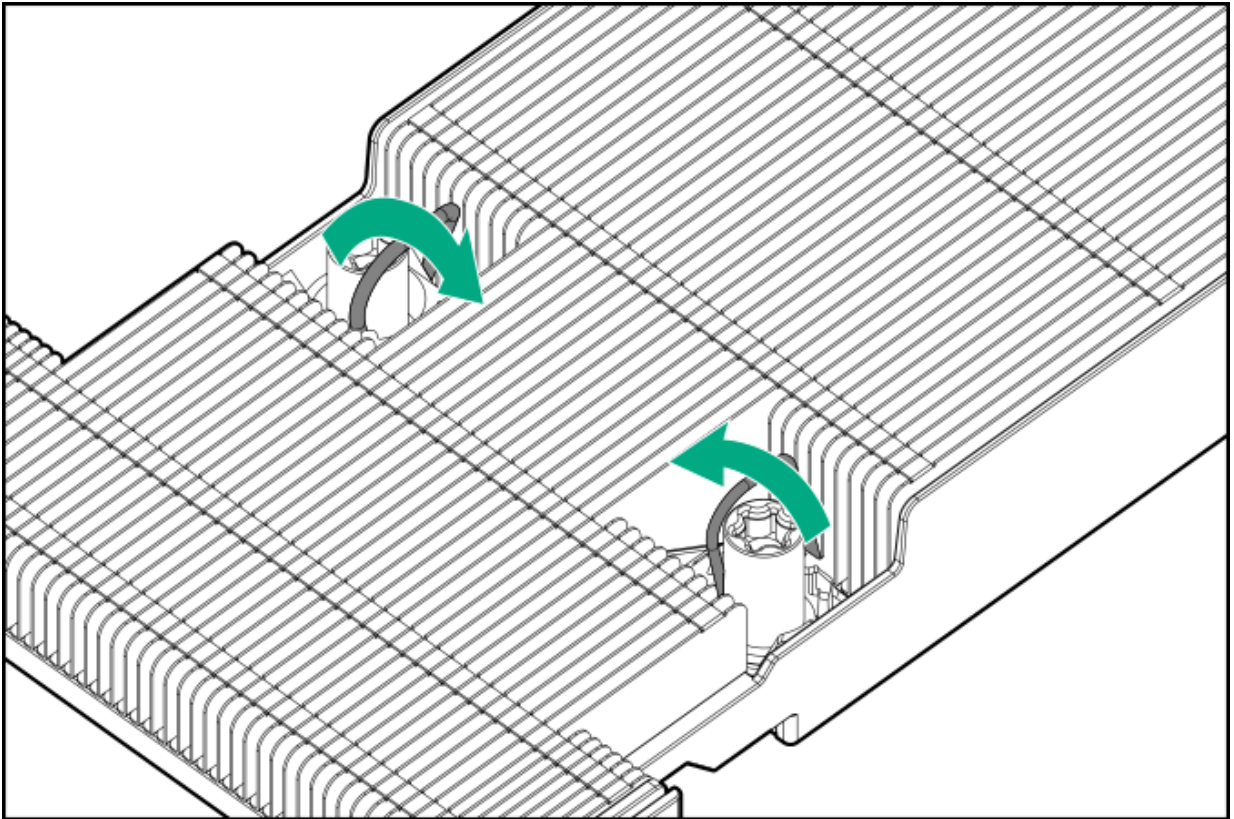

!0.



CAUTION

To prevent mechanical damage or depositing oil on your hands or other contaminants to the heatsink contact surface, hold the heatsink only by the edge of its base plate. Do not touch the heatsink fins.

Lift the processor-heatsink module straight up from the system board.

- Standard heatsink



- High performance heatsink

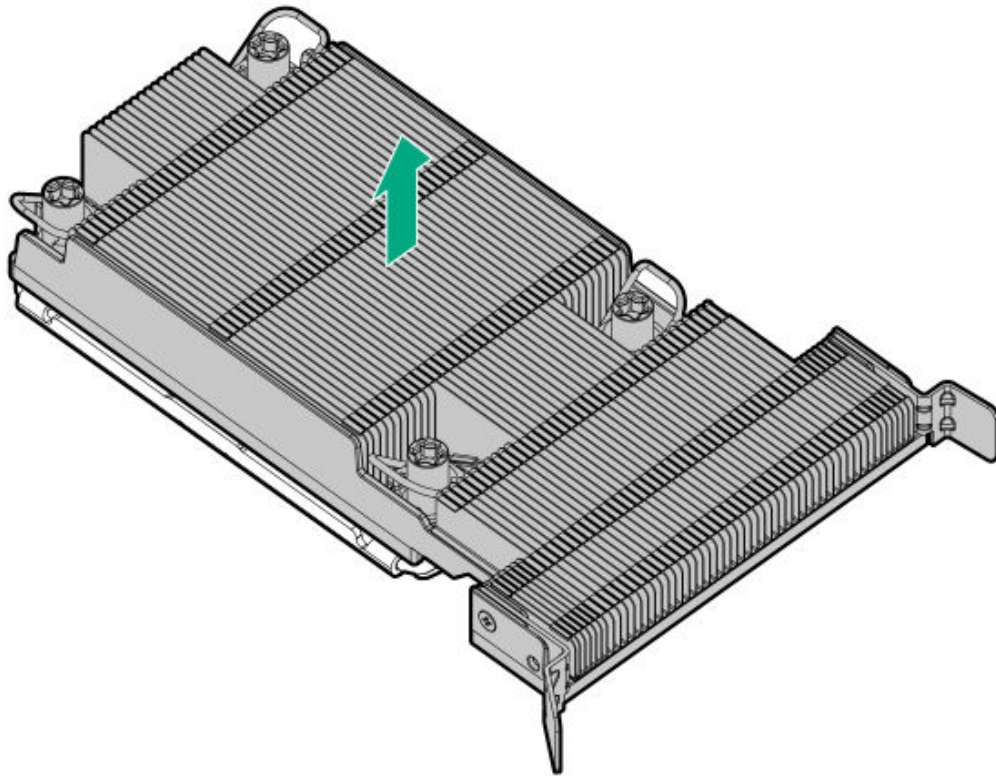

- !1. Place the processor-heatsink module on a flat work surface with its contact side facing up.
- !2. Loosen the system board thumbscrew, and then remove the system board.

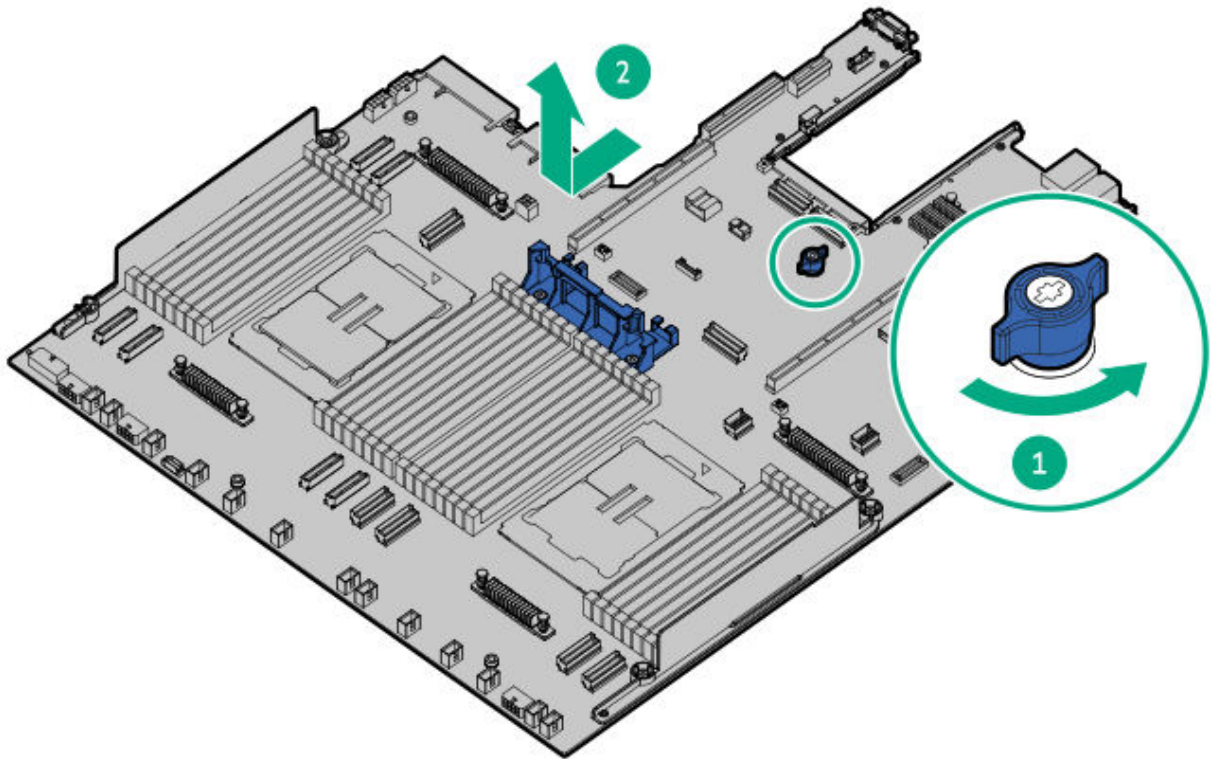

Installing the system board assembly

Prerequisites



CAUTION

Be sure to have the BitLocker recovery key/password prior to replacing the system board. If you do not have the key/password, you will need to reinstall the OS.



CAUTION

Do not use One-button secure erase (OBSE). OBSE should only be used to decommission or repurpose a system. **This option erases all data. Be sure to disconnect any drives, SANs, NAS, or other shared/external storage devices that you do not want erased.**

- Before you perform this procedure, make sure that you have the following items available:
 - T-30 Torx screwdriver or a bit driver with T-30 Torx bit

- T-15 Torx screwdriver
- Thermal grease
- Liquid cooling module handle—This is needed only if the system has a liquid cooling module installed. Use this handle to facilitate the removal and installation of the liquid cooling module when replacing the processor, system board, or liquid cooling module.

The handle can be ordered as a spare (P89110-001).

About this task



CAUTION

A discharge of static electricity from a finger or other conductor might damage system boards or other static-sensitive devices. To prevent damage, observe antistatic precautions.

Procedure

1. Install the spare system board.

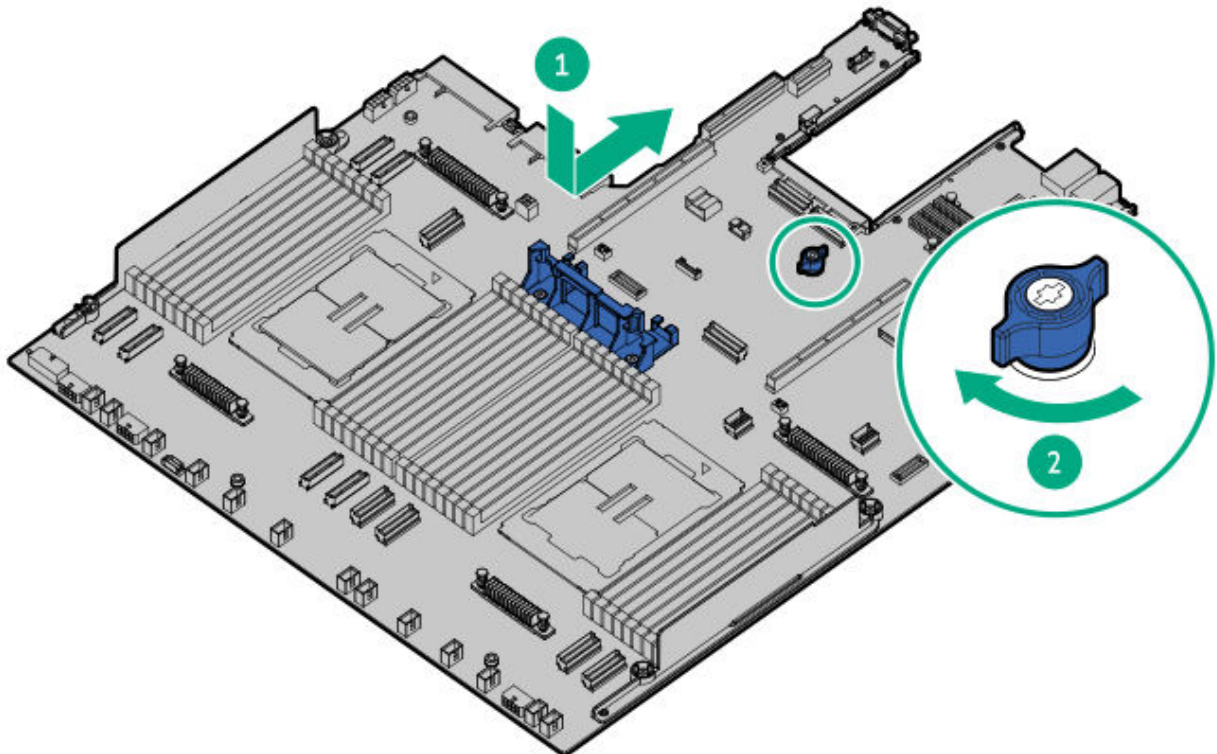

2. Remove the dust cover from the processor socket:

- a. Press and hold the grip tabs on the dust cover.
- b. Lift the dust cover away from the bolster plate.

Retain the cover for future use.

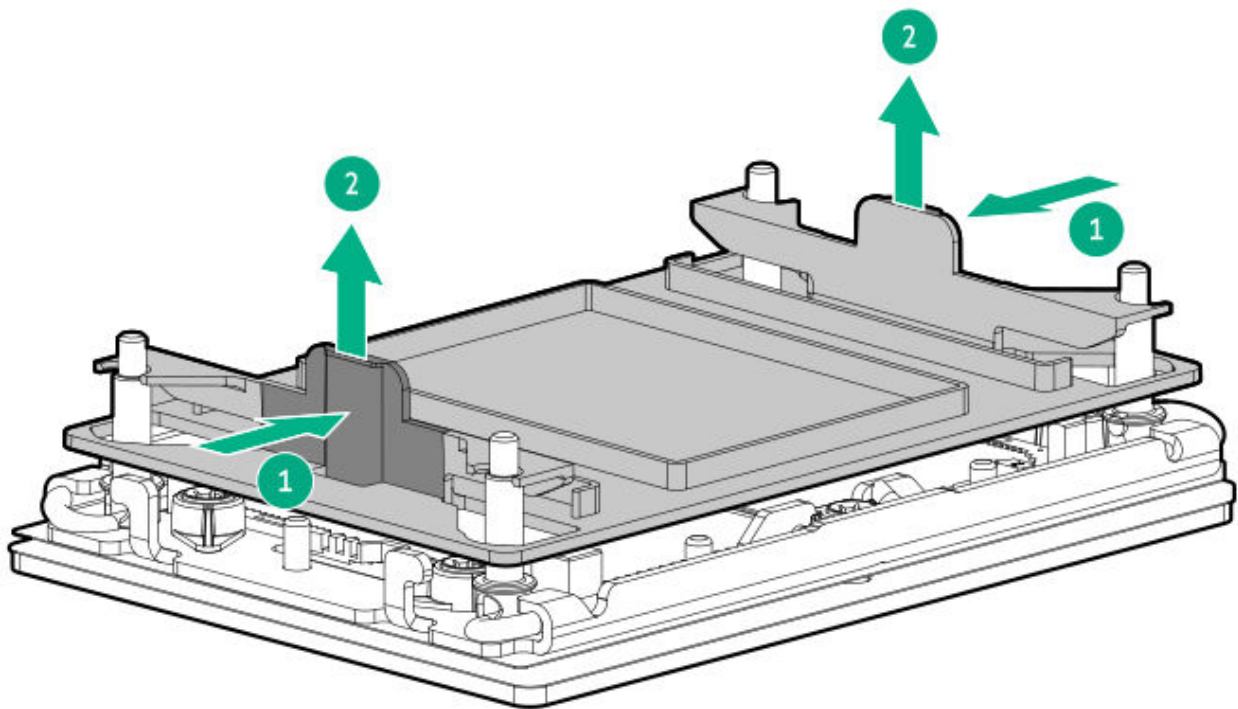

3. If the system uses standard or high performance heatsinks, proceed to step [4](#).

If the system uses liquid cooling, [install the liquid cooling module](#) first, and then proceed to step [5](#).

4.



CAUTION

To prevent thermal failure or component damage, do not move the heatsink once the bottom of its base plate touches the top of the processor. Excessive heatsink movement can cause the thermal grease to smear and become uneven. Voids in the compound can adversely impact the transfer of heat away from the processor.

Install the processor-heatsink module:

- a. When using a torque wrench to tighten the heatsink screws, set 0.9 N-m (8 in-lb) of torque.
- b. Note the **Front of server** text on the heatsink label to correctly orient the processor-heatsink module over the bolster plate.
- c. Carefully lower the processor-heatsink module onto the bolster plate guide posts.

The posts are keyed so that the module can only be installed one way. Make sure that the module is properly seated on the bolster plate before securing the screws.

- Standard heatsink

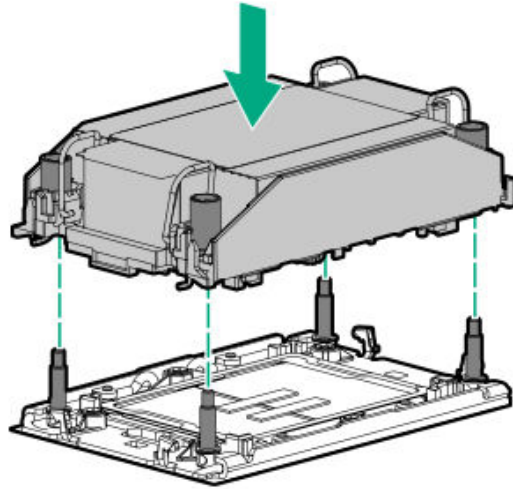

- High performance heatsink

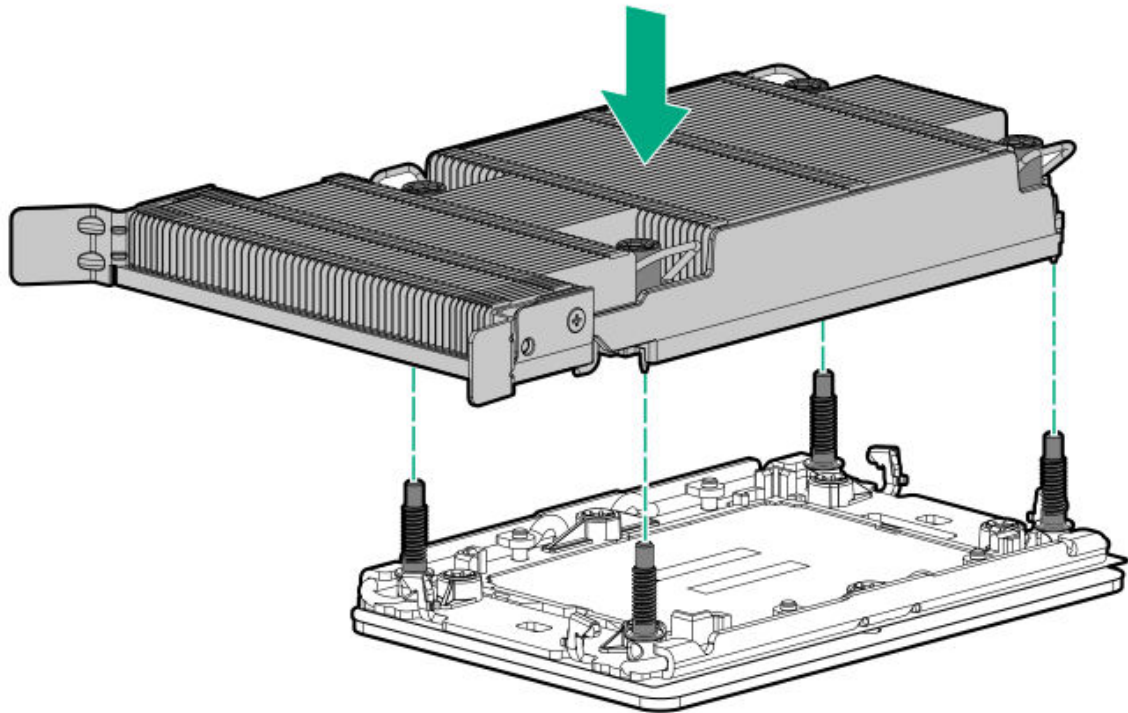

d. Set the anti-tilt wires to the locked position.



e. Tighten one pair of diagonally opposite heatsink screws, and then tighten the other pair of heatsink screws.

- Standard heatsink

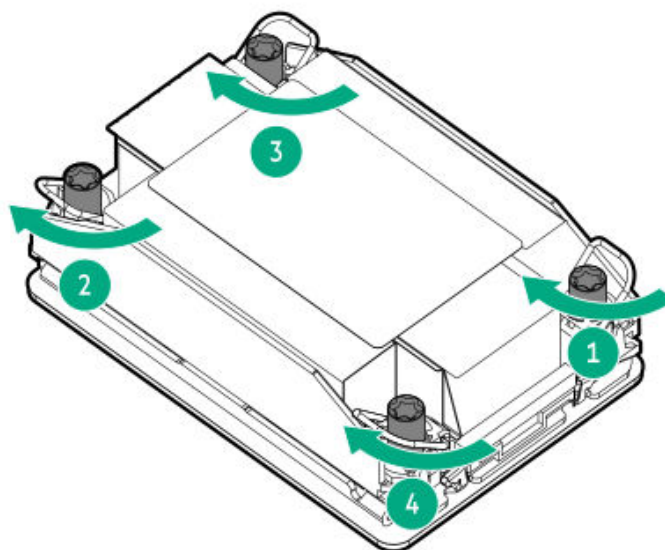

- High performance heatsink

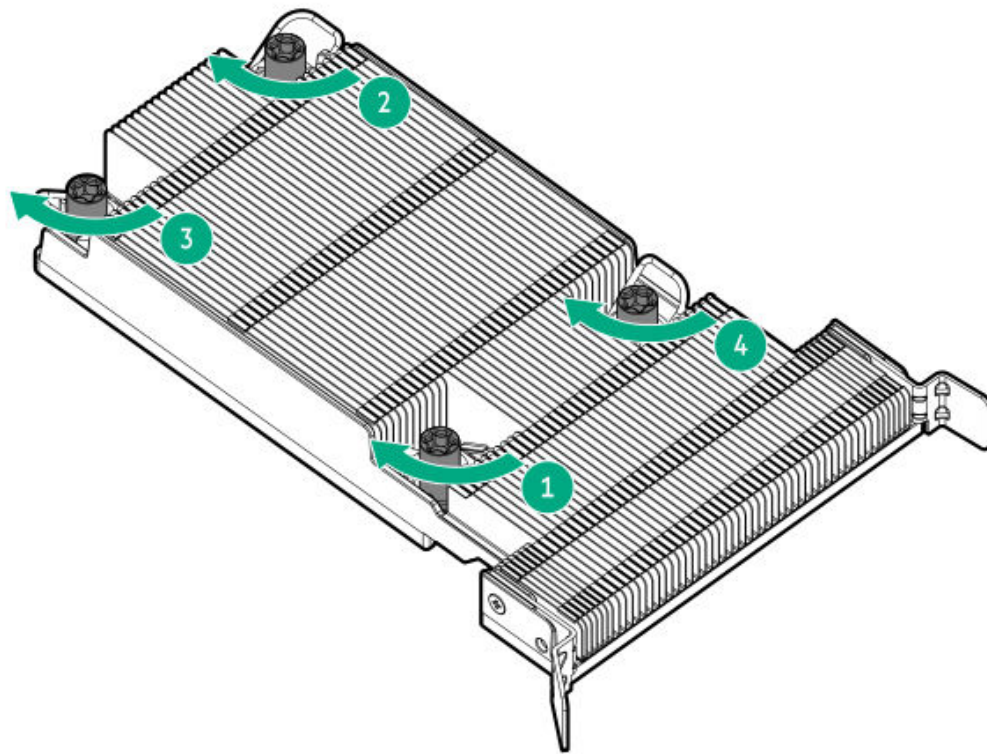

5. Install all components removed from the failed system board.

Be sure to install the DIMMs in the same DIMM slots as the failed system board.

6. Install all fans.
7. Install the air baffle.

Installation of the air baffle requires high performance heatsinks. The air baffle is secured by two system board standoffs in the chassis. These standoffs are preinstalled on the system. If your system does not include the required standoffs, contact **HPE support**.

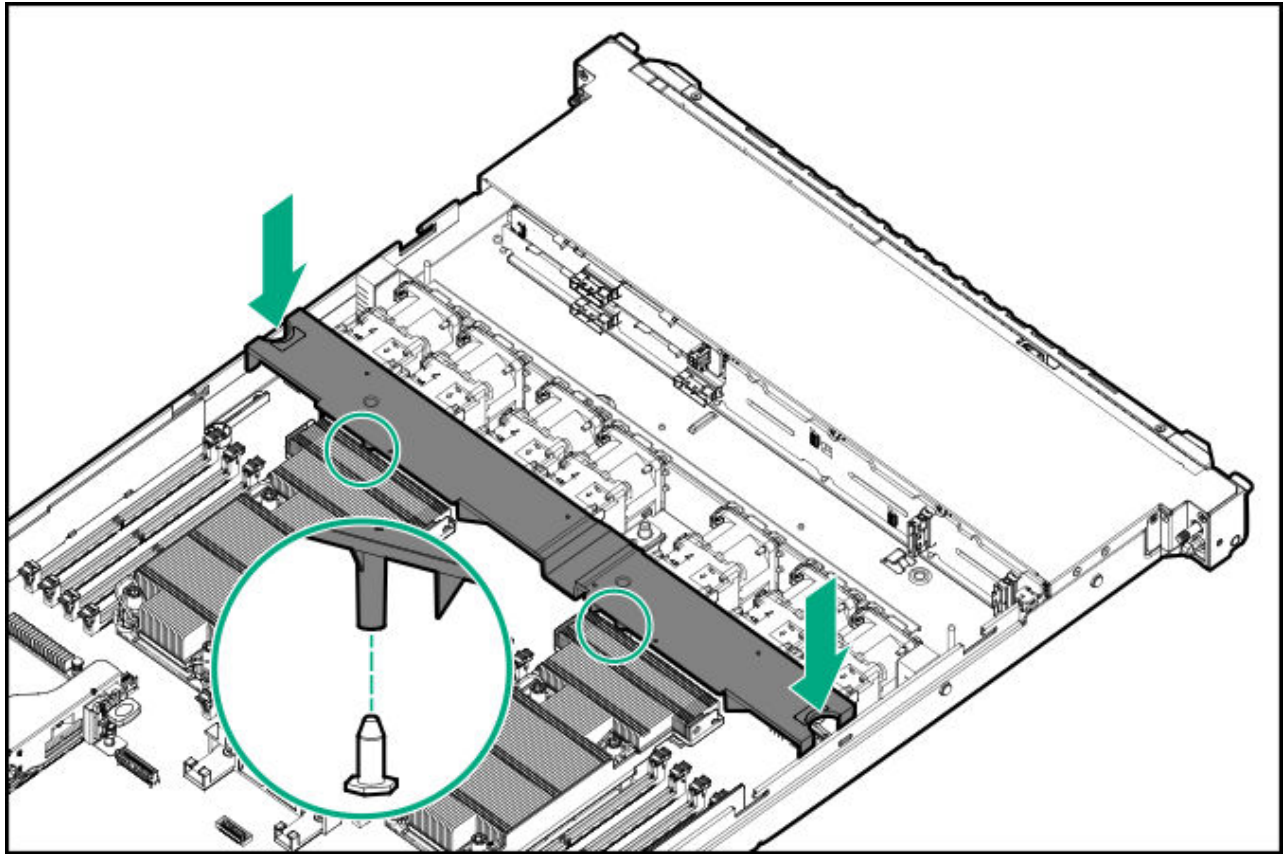

8. Install the access panel.
9. Install all power supplies.
- .0. If the server was removed from an enclosure or a rack, reinstall it now.
- .1. If the system uses direct liquid cooling, connect the DLC kit to the rack manifold.
- .2. Connect all peripheral cables to the server.
- .3. Connect each power cord to the server.
- .4. Connect each power cord to the power source.
- .5. Power up the server.
- .6. Update all firmware to the same versions as before.
- .7. Re-enter the server serial number and product ID.
- .8. Re-enter any Secure Boot keys that were previously added in the Secure Boot configuration.

9. See the applicable OS documentation for procedures and recommendations on restoring the OS and accessing drive data.



CAUTION

(For Microsoft Windows only) After replacing the system board, we recommend using BitLocker Recovery to restore the OS and access drive data. The recovery key/password previously generated during the initial server installation and BitLocker setup is required to enter Recovery Mode.

For more information about BitLocker Recovery, see the [Microsoft website](#).

Results

The replacement procedure is complete.

Re-entering the server serial number and product ID

About this task

After replacing the system board, re-enter the system serial number and product ID.

Procedure

1. Access the UEFI System Utilities. During POST, press **F9**.
2. From the **System Utilities** screen, select **System Configuration > BIOS/Platform Configuration (RBSU) > Advanced Options > Advanced Service Options**.
3. Select **Serial Number**, and then press **Enter**.

The following warning appears:

```
The serial number is modified by qualified service personnel and must match the serial number located on the chassis.
```

4. Click **OK**.
5. Type the serial number, and then press **Enter**.
6. Select **Product ID**, and then press **Enter**.

The following warning appears:

```
Product ID is modified only by qualified service personnel. This value must match the product ID located on the chassis.
```

7. Type the product ID, and then press **Enter**.
8. To confirm and save the settings, press **F12**.

The server automatically reboots.

Results

The installation procedure is complete.

Component identification

Provides an overview of external and internal server features to support hardware installation and servicing.

Subtopics

Front panel components

Front panel LEDs and buttons

Rear panel components

Rear panel LEDs

Component touchpoints

System board components

Drive bay numbering

Drive backplane naming

OCP NIC 3.0 slot numbering

HPE Basic Drive LED definitions

EDSFF SSD LED definitions

Fan numbering

Heatsink and processor socket components

Closed-loop liquid cooling (CLLC) module components

DLC module components

Liquid cooling guidelines

HPE NS204i-u Boot Device V2 components

HPE NS204i-u Boot Device V2 LED definitions

Riser board components

Riser slot numbering

Front panel components

4 LFF

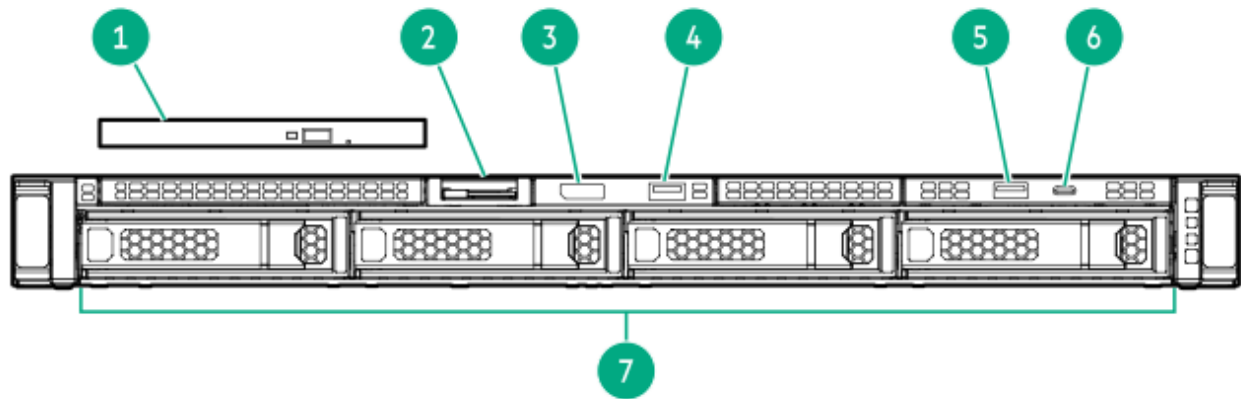

Item	Description
1	Optical drive (optional) ¹
2	Serial number/iLO information pull tab ²
3	DisplayPort (optional)
4	USB 2.0 port (optional)
5	USB 3.2 Gen 1 port
6	iLO service port (USB Type C) ³
7	Drive bays

¹ This option replaces a blank shown on the front panel.

² The serial number / iLO information pull tab is double-sided. One side shows the server serial number and the customer asset tag label. The other side shows the default iLO account information.

³ The operating system does not recognize this port as a USB port.

8 + 2 SFF

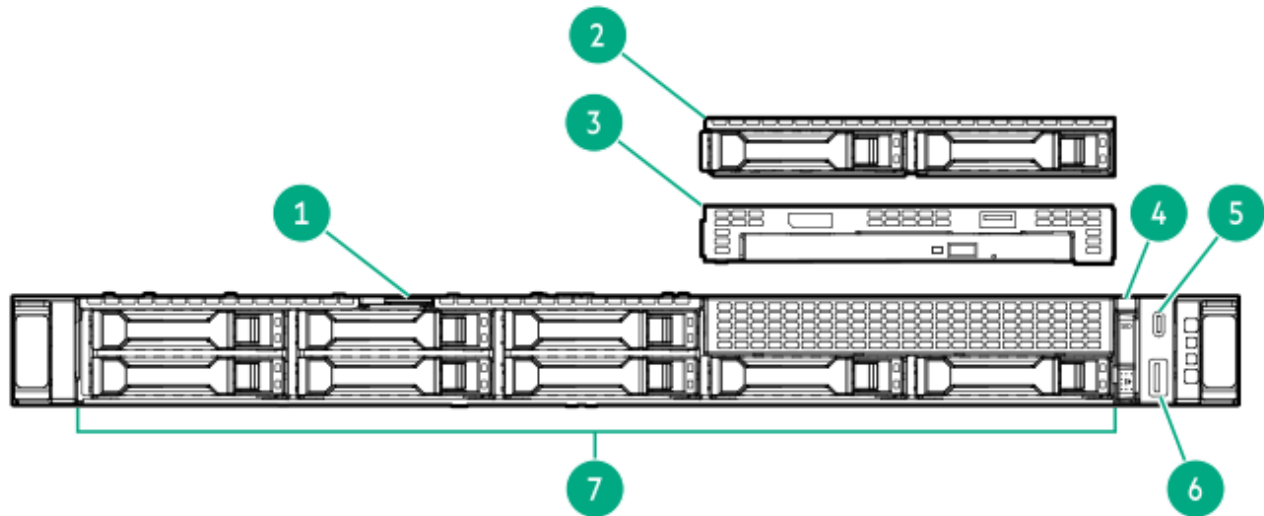

Item	Description
1	Serial number/iLO information pull tab ¹
2	2 SFF side-by-side drive cage assembly (optional) ²
3	DisplayPort / USB 2.0 / optical drive (optional) ³
4	System Insight Display (optional) ³
5	iLO service port (USB Type C) ⁴
6	USB 3.2 Gen 1 port
7	Drive bays

¹ The serial number / iLO information pull tab is double-sided. One side shows the server serial number and the customer asset tag label. The other side shows the default iLO account information.

² This option replaces a blank shown on the front panel.

³ This System Insight Display is only supported in the 8 SFF drive configuration.

⁴ The operating system does not recognize this port as a USB port.

10 SFF / 20 E3.S

The 10 SFF / 20 E3.S server supports hardware options for the mixed drive type configuration.

- 10 SFF

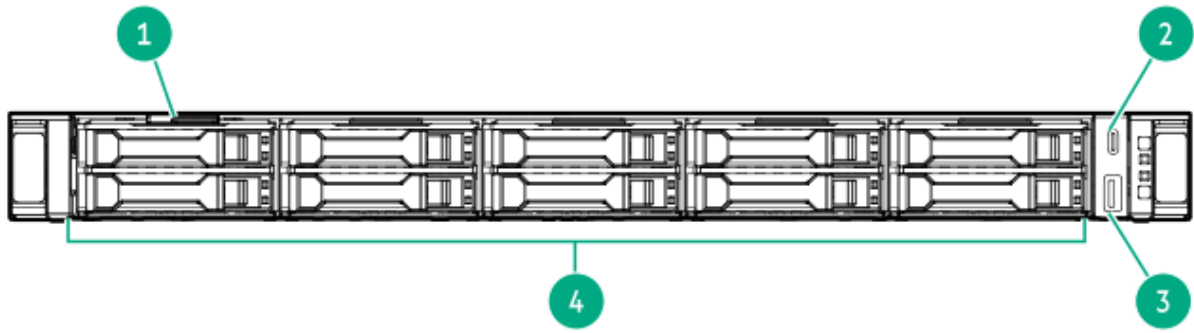

- 20 E3.S

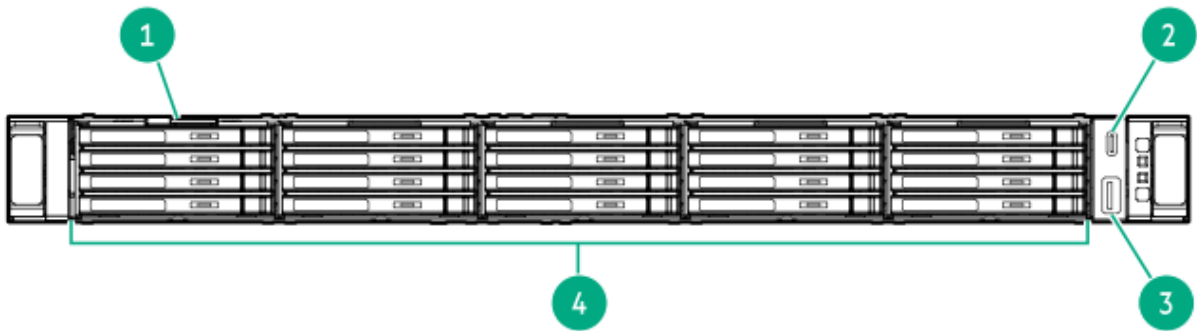

Item	Description
1	Serial number/iLO information pull tab ¹ ₂
2	iLO service port (USB Type C) ³ ₂
3	USB 3.2 Gen 1 port
4	Drive bays

- ¹ ₂ The serial number / iLO information pull tab is double-sided. One side shows the server serial number and the customer asset tag label. The other side shows the default iLO account information.
- ² ₂ A 2 SFF / 4 E3.S stacked drive cage must be installed in Drive Box 1 to support the serial number/iLO information pull tab.
- ³ ₂ The operating system does not recognize this port as a USB port.

Mixed drive type configuration with options

On the servers supporting mixed drive types, each of the drive boxes can have a different drive cage option or media device option installed.

For more information on the supported front drive cage options, see the product QuickSpecs on the Hewlett Packard Enterprise website (<https://www.hpe.com/info/quickspecs>).

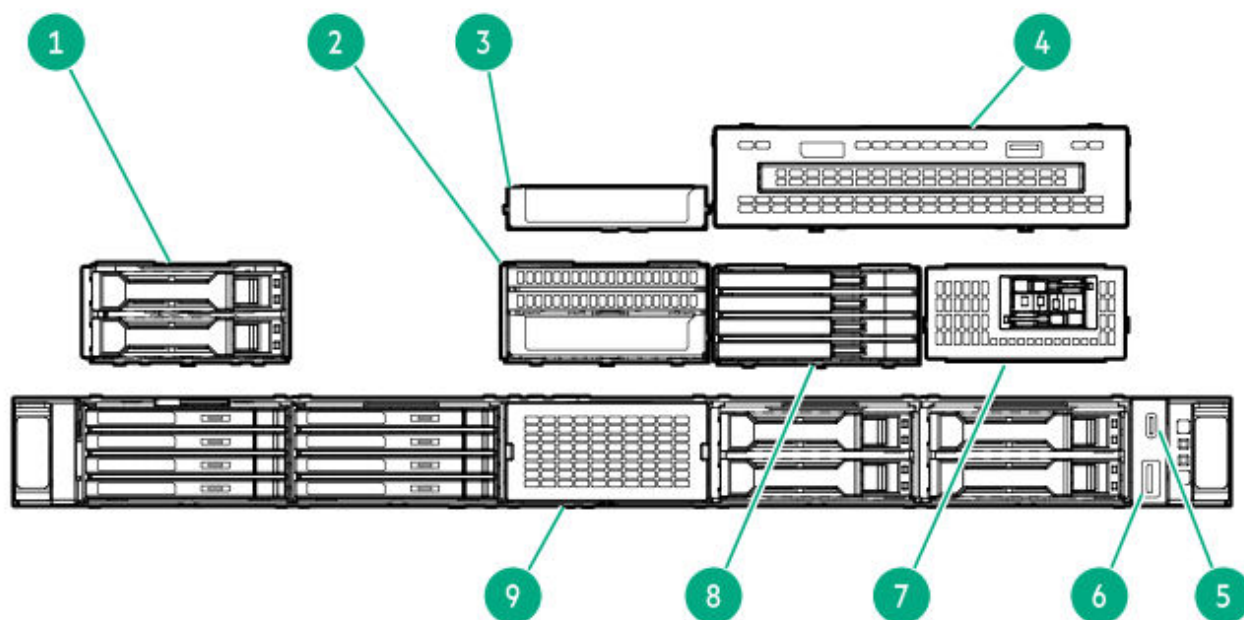

Item	Description
1	Stacked 2 SFF drive cage assembly (optional)
2	Primary front OCP NIC enablement kit (optional) ¹
3	Secondary front OCP NIC enablement kit (optional)
4	DisplayPort / USB 2.0 / optical drive (optional) ²
5	iLO service port (USB Type C) ³
6	USB 3.2 Gen 1 port
7	Front NS204i-u enablement kit (optional) ⁴
8	Stacked 4 E3.S drive cage assembly (optional)
9	Drive box blank ⁵

- ¹ The front OCP option is supported in Box 3.
² The media device option is supported in Boxes 4-5.
³ The operating system does not recognize this port as a USB port.
⁴ The front NS204i-u is supported in Box 5.
⁵ This blank is required if the drive box does not have an option installed.

Front panel LEDs and buttons

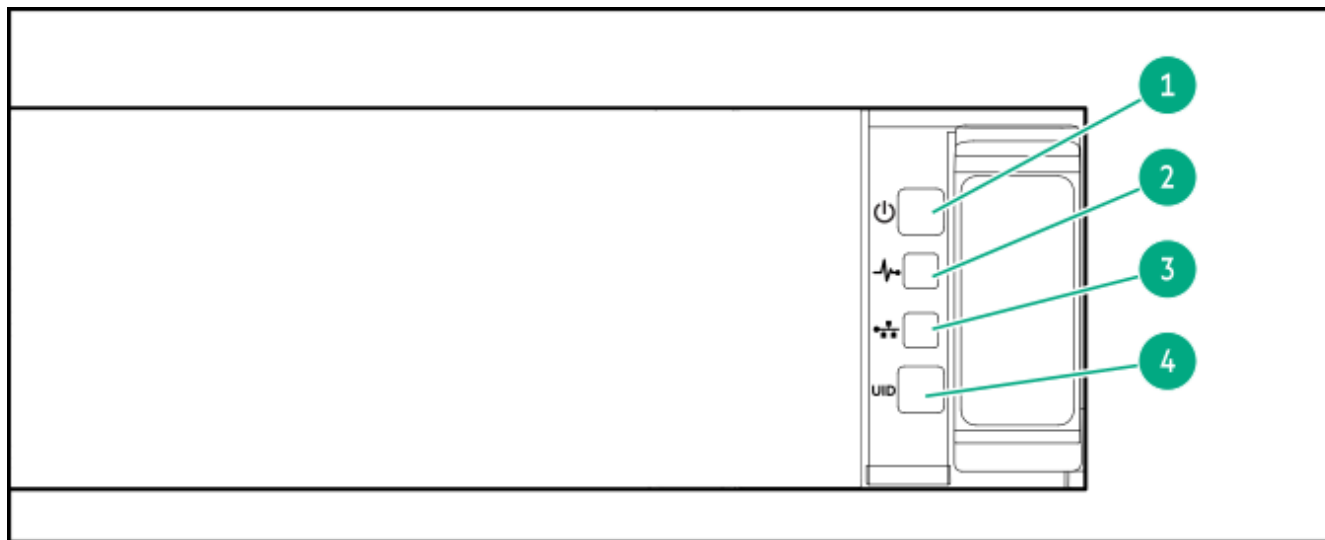

Item	Description	Status
1	Power On/Standby button and system power LED ¹	<p>Solid green = System on</p> <p>Flashing green = Performing power on sequence</p> <p>Solid amber = System in standby</p> <p>Off = No power present ¹</p>
2	Health LED ¹	<p>Solid green = Normal</p> <p>Flashing green = iLO is rebooting.</p> <p>Flashing amber = System degraded</p> <p>Flashing red = System critical ²</p>
3	NIC status LED ^{1, 3}	<p>Solid green = Link to network</p> <p>Flashing green = Network active</p> <p>Off = No network activity</p>
4	UID button/LED ⁴	<p>Solid blue = Activated</p> <p>Flashing blue:</p> <ul style="list-style-type: none"> • 1 Hz = Remote management or firmware upgrade in progress • 4 Hz = iLO manual reboot sequence initiated • 8 Hz = iLO manual reboot sequence in progress

Item	Description	Status
		Off = Deactivated

- 1 Facility power is not present, power cord is not attached, no power supplies are installed, power supply failure has occurred, or the power button cable is disconnected.
- 2 If the health LED indicates a degraded or critical state, review the system IML or use iLO to review the system health status.
- 3 NIC status LED does not support NIC LED ACT/LINK indication from OCP NICs without Scan Chain feature, or PCIe NICs.
- 4 When all four LEDs described in this table flash simultaneously, a power fault has occurred.

Subtopics

[UID button functionality](#)

[System Insight Display LEDs](#)

[System Insight Display combined LED descriptions](#)

UID button functionality

The UID button can be used to identify a specific server in a rack or display the Server Health Summary when the server will not power on. For more information, see the latest HPE iLO User Guide on the [Hewlett Packard Enterprise website](#).

System Insight Display LEDs

The System Insight Display (SID) LEDs represent components on the system board. The display enables component issue diagnosis even with the access panel installed.



IMPORTANT

If more than one DIMM slot LED is illuminated, further troubleshooting is required. Test each bank of DIMMs by removing all other DIMMs. Isolate the failed DIMM by replacing each DIMM in a bank with a known working DIMM.

For information about memory population rules, see the relevant memory technical paper in:

<https://www.hpe.com/docs/server-memory>

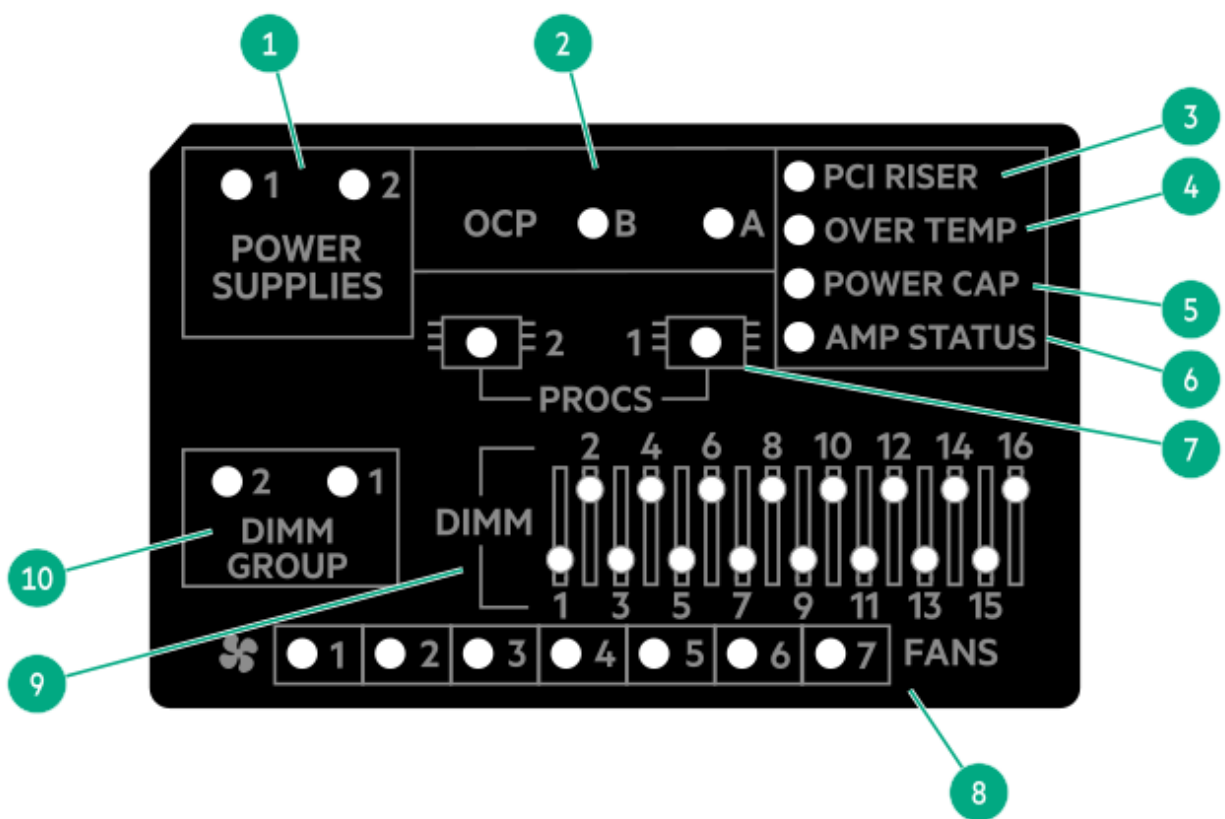

Item	LED	Status	Description
1	Power supply LEDs	Off	Normal
		Solid amber	One or more of the following conditions exists: <ul style="list-style-type: none"> Power subsystem degraded Power supply failure Input power lost
2	OCP LEDs	Solid green	Network link
		Flashing green	Network active
		Off	No network link
3	PCI riser LED	Off	Normal
		Solid amber	Incorrectly installed PCI riser cage
4	Over temp LED	Off	Normal
		Solid amber	High system temperature detected

Item	LED	Status	Description
5	Power cap LED	Solid green	Power cap applied
		Off	One or more of the following conditions exists: <ul style="list-style-type: none"> • System is in standby • No cap is set
6	AMP ¹	Solid green	AMP mode enabled
		Solid amber	Failover
		Flashing amber	Invalid configuration
		Off	AMP modes disabled
7	Processor LED	Off	Normal
		Solid amber	Failed processor
8	Fan LEDs	Off	Normal
		Solid amber	Failed fan or missing fan
9	DIMM LEDs	Off	Normal
		Solid amber	Failed DIMM or configuration issue
10	DIMM group LEDs	Off	Normal
		Solid amber	Failed DIMM group or configuration issue

¹ To enable Advanced Memory Protection (AMP), see the UEFI user guide (<https://www.hpe.com/support/hpeuefisystemutilities-quicklinks>).

When the health LED on the front panel illuminates either amber or red, the server is experiencing a health event. For more information on the combination of these LEDs, see [System Insight Display combined LED descriptions](#).

System Insight Display combined LED descriptions

The combined illumination of the following LEDs indicates a system condition:

- SID LEDs
- System power LED
- Health LED

SID LED status	Health LED status	System power LED status	LED Definition
Power supply (solid amber)	Flashing red	Solid amber	One or more of the following conditions exist: <ul style="list-style-type: none"> Only one power supply is installed and that power supply is in standby. Power supply fault. System board fault.
	Flashing amber	Solid green	One or more of the following conditions exist: <ul style="list-style-type: none"> Redundant power supply is installed and only one power supply is functional. AC power cord is not plugged into redundant power supply. Redundant power supply fault. Power supply mismatch at POST or power supply mismatch through hot-plug addition.
PCI riser (solid amber)	Flashing red	Solid green	The PCI riser cage is not seated properly.
Over temp (solid amber)	Flashing amber	Solid green	The Health Driver has detected a cautionary temperature level.
	Flashing red	Solid amber	The server has detected a hardware critical temperature level.
Power cap (solid green)	—	Solid green	Power is available.
Power cap (solid green)	—	Flashing green	Waiting for power
Power cap (flashing amber)	—	Solid amber	Power is not available.
Power cap (off)	—	Solid amber	Standby
Processor (solid amber)	Flashing red	Solid amber	One or more of the following conditions might exist: <ul style="list-style-type: none"> Processor in socket X has failed. Processor X is not installed in the socket. Processor X is unsupported. ROM detects a failed processor during POST.
	Flashing amber	Solid green	Processor in socket X is in a pre-failure condition.

SID LED status	Health LED status	System power LED status	Definition
Fan (solid amber)	Flashing amber	Solid green	One fan has failed or has been removed.
	Flashing red	Solid green	Two or more fans have failed or been removed.
DIMM (solid amber)	Flashing red	Solid green	One or more DIMMs have failed.
	Flashing amber	Solid green	DIMM in slot X is in a pre-failure condition.

Rear panel components

Rear panel with 3 PCIe slots

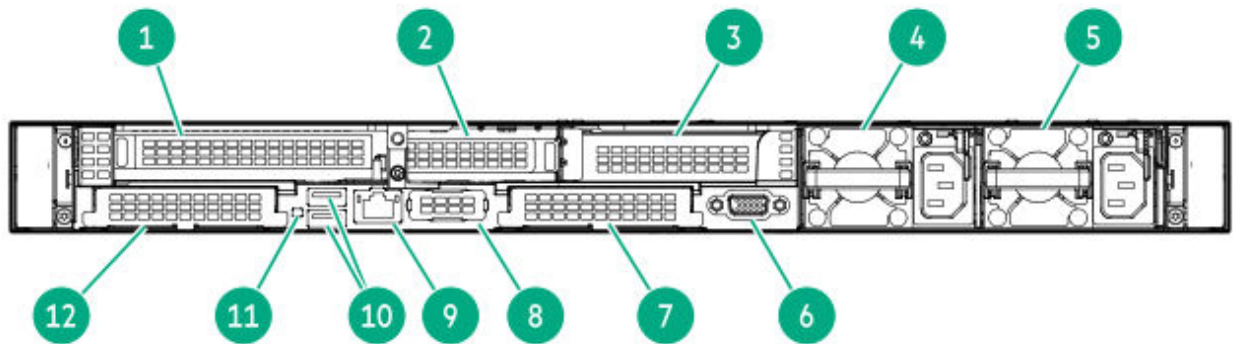

Item	Description
1	Slot 1 PCIe5 ¹
2	Slot 2 PCIe5 ²
3	Slot 3 PCIe5 (optional - requires the secondary processor) ³
4	Power supply 2 (PS2)
5	Power supply 1 (PS1)
6	Video (VGA) port
7	OCP 3.0 slot B (Slot 15)
8	Serial port (optional)
9	iLO Management Port
10	USB 3.2 Gen 1 ports
11	Rear UID button / LED

Item	Description
12	OCP 3.0 slot A (Slot 14)

- ¹ This slot supports the full-height PCIe form factor.
- ² This slot supports the low-profile PCIe form factor.
- ³ This slot requires the low-profile riser kit option (P48903-B21).

Rear panel with 2 PCIe slots

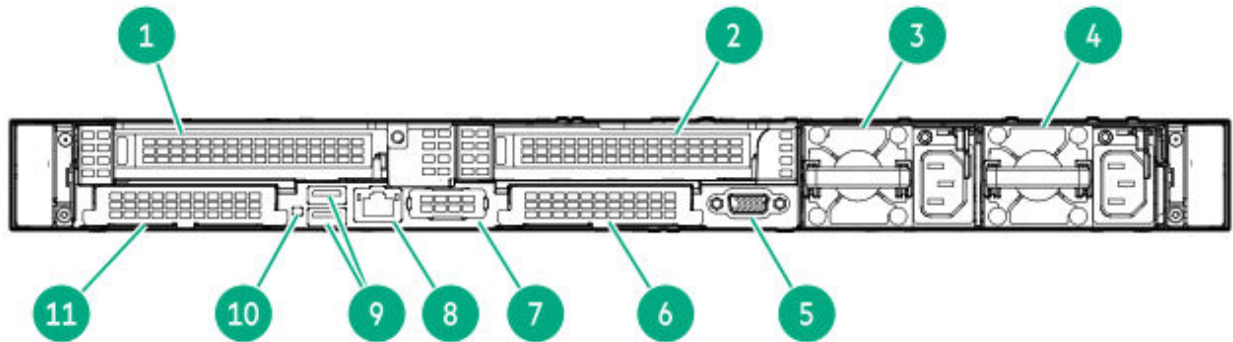

1	Slot 1 PCIe5 ¹
2	Slot 3 PCIe5 (optional - requires the secondary processor) ²
3	Power supply 2 (PS2)
4	Power supply 1 (PS1)
5	Video (VGA) port
6	OCP 3.0 slot B (Slot 15)
7	Serial port (optional)
8	iLO Management Port
9	USB 3.2 Gen 1 ports
10	Rear UID button / LED
11	OCP 3.0 slot A (Slot 14)

- ¹ This slot supports the full-height PCIe form factor.
- ² This slot requires the full-height riser kit option (P72598-B21).

Rear panel LEDs

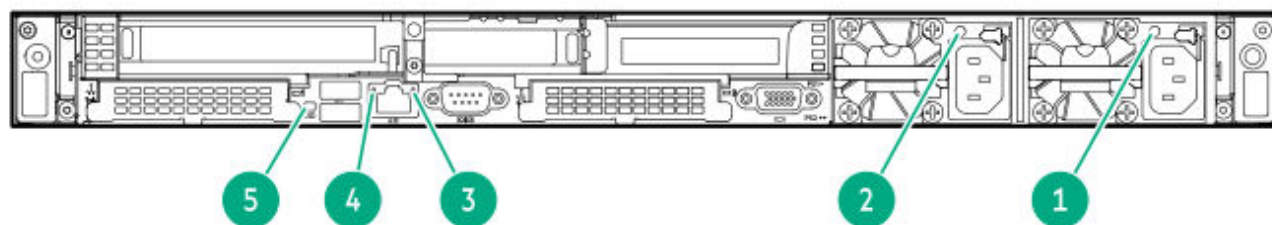

Item	Description	Status
1	Power supply 1 LED	<p>Solid green — Normal</p> <p>Off — One or more of the following conditions exists:</p> <ul style="list-style-type: none"> • AC power unavailable • Power supply failed • Power supply in standby mode • Power supply exceeded current limit. • Power cord is not attached.
2	Power supply 2 LED	<p>Solid green — Normal</p> <p>Off — One or more of the following conditions exists:</p> <ul style="list-style-type: none"> • AC power unavailable • Power supply failed • Power supply in standby mode • Power supply exceeded current limit. • Power cord is not attached.
3	iLO status	<p>Solid green — Linked to network</p> <p>Flashing green — Network active</p> <p>Off — No network activity</p>
4	iLO link	<p>Solid green — Link exists.</p> <p>Off — No link exists.</p>
5	UID LED	Solid blue — Identification is activated.

Item	Description	Status
		Flashing blue — System is being managed remotely.
		Off — Identification is deactivated.

Component touchpoints

Certain components are color-coded. These colors represent the recommended touch areas for a removal process and indicate whether components require a system shutdown before removal.

The following diagrams are examples only.

HPE hot-plug red

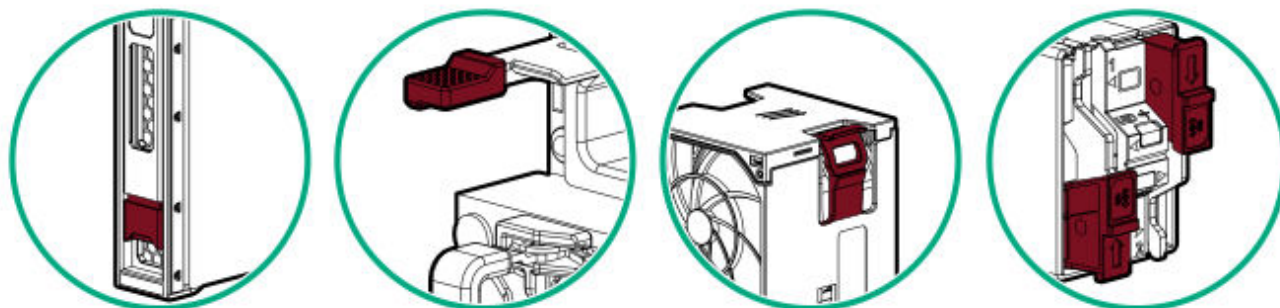

Hot-plug red indicates hot-pluggable components. These components can be removed and installed while the system is running, and doing so will not result in a system shutdown.

Component examples:

- Power supplies in a redundant power configuration
- Hot-plug fans
- Hot-plug drives
- M.2 SSDs in a hot-plug boot device

HPE touchpoint blue



Touchpoint blue indicates cold-pluggable components. These components require a system shutdown. Failure to do so might result in system failure or data loss. Cold-pluggable components might also indicate touchpoints on non-electrical components.

Component examples:

- Storage devices
- Fan cages
- System boards
- Energy packs

System board components

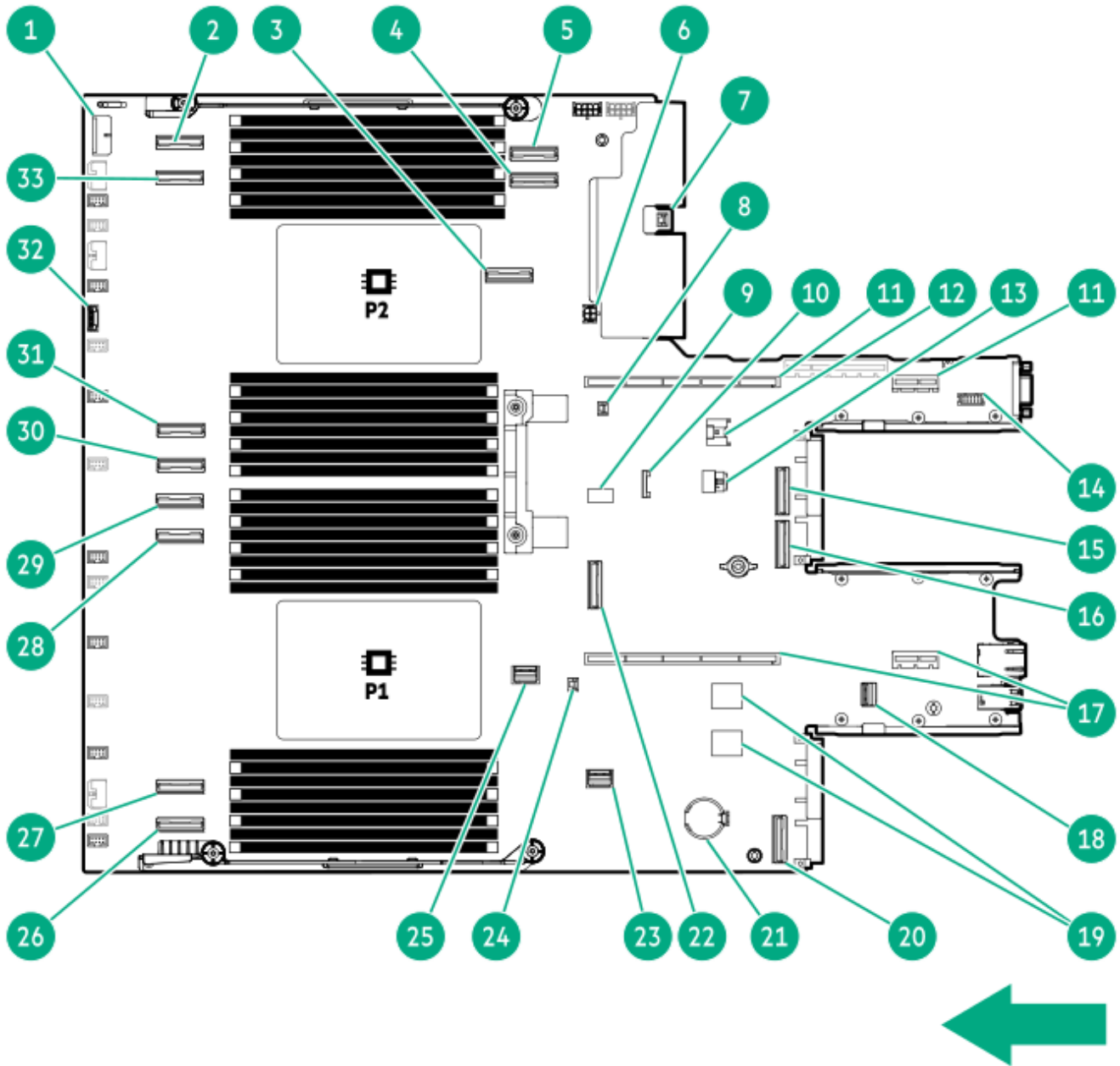

Item	Description
1	Box 1 drive backplane power connector
2	MCIO port 8
3	MCIO port 11
4	MCIO port 10

Item	Description
5	MCIO port 9
6	SmartNIC 4-pin power connector ¹ _—
7	Chassis Intrusion Detection switch connector
8	Storage backup power connector 2
9	<u>System maintenance switch</u>
10	SID connector
11	Secondary riser connectors
12	Energy pack connector
13	NS204i-u power connector
14	Serial port connector
15	OCP B internal port 1
16	OCP B internal port 2
17	Primary riser connectors
18	Front DisplayPort/USB 2.0 connector
19	Internal dual USB 3.2 Gen1 ports
20	OCP A internal port 1
21	System battery
22	MCIO port 12
23	Front I/O connector & USB 3.2 Gen 1 port connector
24	Storage backup power connector 1
25	NS204i-u signal connector
26	MCIO port 1
27	MCIO port 2
28	MCIO port 3
29	MCIO port 4
30	MCIO port 5
31	MCIO port 6
32	Cooling module connector
33	MCIO port 7

¹_— There is no available SmartNIC 4-pin power cable option.

Subtopics

System maintenance switch descriptions

DIMM label identification

DIMM slot locations

PCIe connector and processor matrix

System maintenance switch descriptions

Position	Default	Function
S1	Off	<ul style="list-style-type: none">Off—iLO 7 security is enabled.On—iLO 7 security is disabled.
S2	Off	Reserved
S3	Off	Reserved
S4	Off	Reserved
S5	Off	<ul style="list-style-type: none">Off—Power-on password is enabled.On—Power-on password is disabled.
S6 ^{1, 2}	Off	<ul style="list-style-type: none">Off—No functionOn—Restore default manufacturing settings
S7	Off	Reserved
S8	Off	Reserved
S9	Off	Reserved
S10	Off	Reserved
S11	Off	Reserved
S12	Off	Reserved

¹ When the system maintenance switch position 6 is set to the On position, the system is prepared to restore all configuration settings to their manufacturing defaults.

² When the system maintenance switch position 6 is set to the On position and Secure Boot is enabled, some configurations cannot be restored. For more information, see [Configuring the server](#).

DIMM label identification

To determine DIMM characteristics, see the label attached to the DIMM. The information in this section helps you to use the label to locate specific information about the DIMM.

For more information about product features, specifications, options, configurations, and compatibility, see the HPE DDR5 SmartMemory QuickSpecs:

<https://www.hpe.com/docs/server-memory>

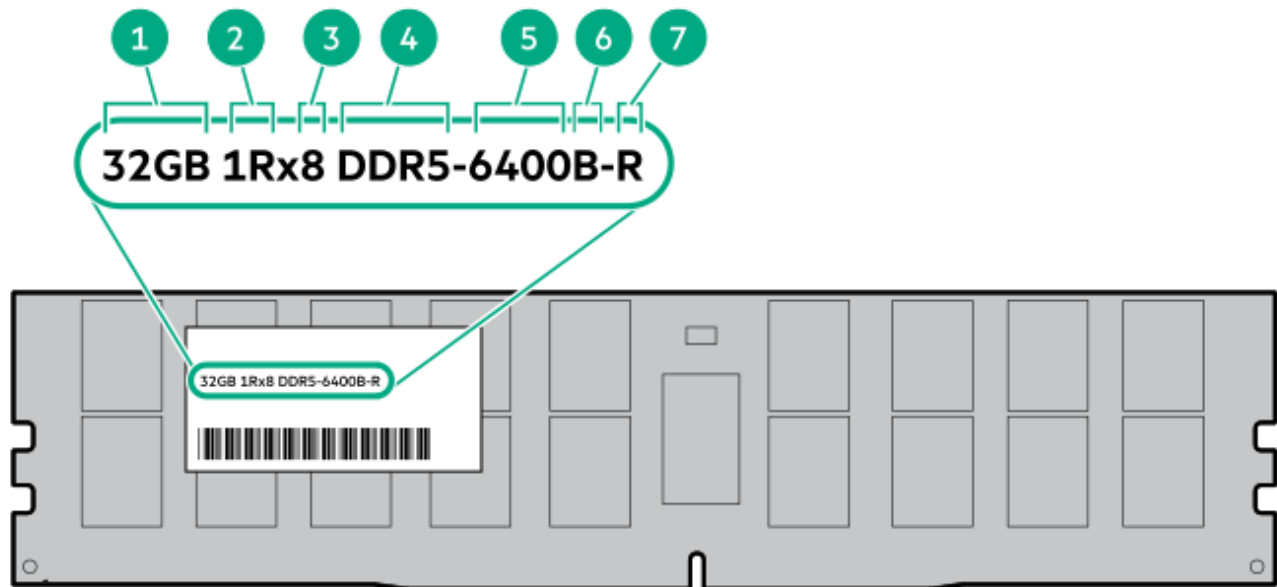

Item	Description	Example
1	Capacity*	16 GB 32 GB 64 GB 96 GB 128 GB 256 GB
2	Rank	1R—Single rank 2R—Dual rank 4R—Quad rank
3	Data width on DRAM	x4—4-bit x8—8-bit

Item	Description	Example
4	Memory generation	PC5—DDR5
5	Maximum memory speed*	6400 MT/s
6	CAS latency	B—42-42-42
7	DIMM type	R—RDIMM (registered)

* The maximum memory speed and capacity is a function of the memory type, memory configuration, and processor model.

DIMM slot locations

DIMM slots are numbered sequentially (1 through 16) for each processor.



PCIe connector and processor matrix

The server's system board connectors support PCIe Gen5. Use the following table to identify the processors and the specific PCIe connectors to which devices are connected.

System board connector	PCIe lane configuration	Processor <u>1</u>
MCIO port 1	x8	Processor 1
MCIO port 2	x8	Processor 1
MCIO port 3	x8	Processor 1
MCIO port 4	x8	Processor 1
MCIO port 5	x8	Processor 2
MCIO port 6	x8	Processor 2
MCIO port 7	x8	Processor 2

System board connector	PCIe lane configuration	Processor ¹
MCIO port 8	x8	Processor 2
MCIO port 9	x8	Processor 2
MCIO port 10	x8	Processor 2
MCIO port 11	x8	Processor 2
MCIO port 12	x8	Processor 1
Primary riser slot 1 ²	x16	Processor 1
Primary riser slot 2 ²	x16	
Secondary riser slot 3	x16	Processor 2
NS204i-u signal	x4	Processor 1
Rear OCP A ³	x8	Processor 1

- ¹ Certain PCIe lanes are reserved for system functions and are not routed to a physical connector for use by PCIe devices.
- ² The primary riser supports two PCIe slots in the system.
- ³ Rear OCP B is connected to the processor using a cable option. For more information on the PCIe connection to rear OCP B in the system, see [OCP NIC 3.0 slot numbering](#).

Drive bay numbering



CAUTION

When a server is purchased without any drive installed, some drive bays might be empty while other drive bays might be populated with drive blanks. To maintain proper system cooling, do not operate the server without a drive or a drive blank installed.

4 LFF drive bay numbering

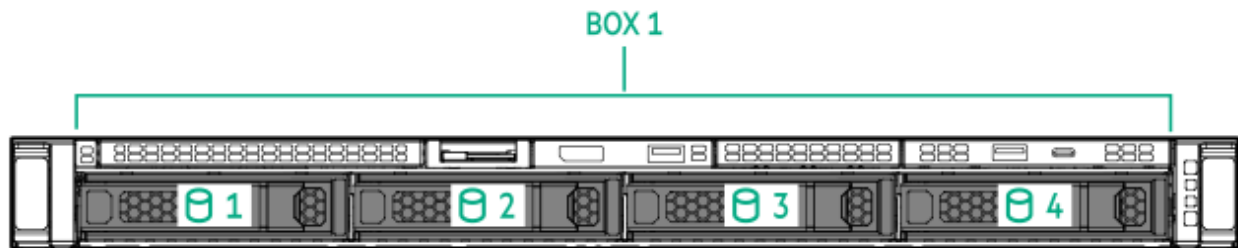

8 SFF drive bay numbering



8 + 2 SFF drive bay numbering

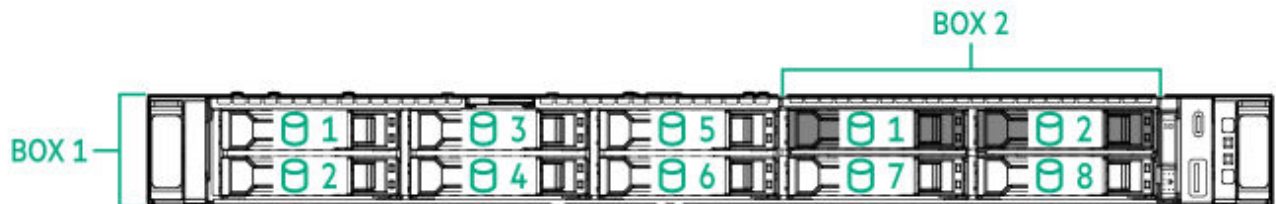

20 E3.S drive bay numbering

This configuration supports mixed drive types in the front drive cages.



10 SFF drive bay numbering

This configuration supports mixed drive types in the front drive cages.

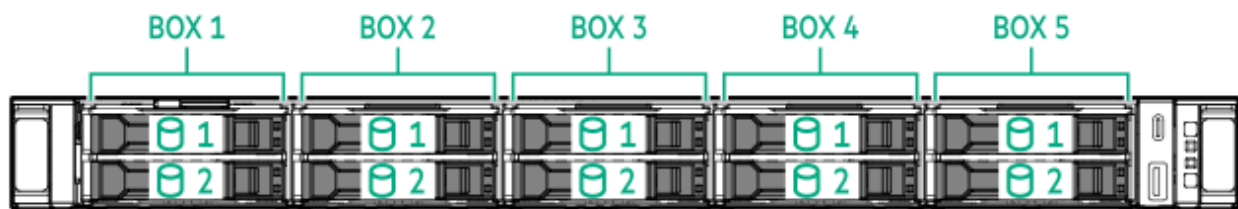

Drive backplane naming

This topic explains the features represented in the drive backplane naming. This naming convention was adopted starting in the HPE Gen11 server release. Your server might not support all the features listed in this topic. For server-specific support information, see the server guides:

- Drive backplane support, see [Drive bay numbering](#).
- Drive backplane cabling, see [Storage cabling](#).



Item	Description	Values
1	Drive bay count	Number of drive bays supported by the backplane.
2	Drive form factor	LFF—Large Form Factor SFF—Small Form Factor E3S—Enterprise and Datacenter Standard Form Factor (EDSFF E3.S)
3	Maximum link rate per lane (GT/s)	12G 16G 24G 32G
4	Port link width and interface	x1 NVMe/SAS—U.3 NVMe, SAS, or SATA ¹ x4 NVMe/SAS—U.3 NVMe, SAS, or SATA ² x4 NVMe—NVMe ³ x4 NVMe—E3.S
5	Universal backplane manager (UBM) model	The UBM model defines the UBM firmware used by the backplane. Examples of UBM models: UBM2, UBM3, and etc.
6	Drive carrier type	BC—Basic carrier (SFF) LP—Low-profile carrier (LFF) EC—E3.S carrier

¹ Tri-mode controller support for x1 U.3 NVMe, SAS, and SATA drives. System board connection supports SATA drives only.

² CPU direct attach or tri-mode controller support for x4 U.3 NVMe, x2 (via a splitter cable) U.3 NVMe, or x1 SAS and SATA drives.

- 3 CPU direct attach or tri-mode controller support for x4 NVMe drives.

OCP NIC 3.0 slot numbering

This server supports up to two OCP NIC 3.0 SFF slots in either the rear or the front panel.

Rear OCP NIC 3.0 slots

The rear OCP NIC 3.0 slots are standard in the system.



Item	Slot number	Supported options
1	Slot 14 OCP A PCIe5 x16 <u>1</u> , <u>2</u> , <u>3</u>	<ul style="list-style-type: none"> • OCP NIC • Type-o storage controller
2	Slot 15 OCP B PCIe5 x16 <u>3</u> , <u>4</u> , <u>5</u> , <u>6</u>	

- ¹ When installing a single OCP NIC, install it in Slot 14 OCP A.
- ² Slot 14 OCP A by default supports x8 connection from processor 1. To upgrade to x16 connection, an OCP A x16 enablement cable option (P72201-B21) is required.
- ³ The PCIe lane configuration for rear OCP slots varies depending on processor count and drive placement. For more information, see [OCP connection and direct attached drives](#).
- ⁴ To support Slot 15 OCP B x8 connection in a single-processor configuration, a CPU1-to-OCP-B cable option (P72203-B21) is required.
- ⁵ To support Slot 15 OCP B x8 connection in a dual-processor configuration, a CPU2-to-OCP-B cable option (P72205-B21) is required.
- ⁶ To upgrade to x16 connection in a dual processor configuration, an OCP B x 16 enablement cable option (P72207-B21) is required.

OCP connection and direct attached drives

In systems that use 4 EDSFF or 2 SFF stacked drives direct attached to the system board, the OCP PCIe connection varies based on the processor count and drive placement. When a data cable from Drive Box 5 occupies MCIO port 12, rear OCP B support may be affected. See the following table for detailed configuration options.

One processor:

Drives ¹	OCP slot	Connection bandwidth	OCP cable option
2 SFF stacked drives in Box 5	OCP A	x8 connection	Not required
	OCP B	Not supported	—
2 SFF stacked drives in Box 3 (relocated from Box 5) ²	OCP A	Up to x16 connection	Required
	OCP B	Not supported	—
2 SFF stacked drives in Box 3 (relocated from Box 5) ²	OCP A	x8 connection	Not required
	OCP B	x8 connection	Required

¹ During the order configuration of the 10 SFF / 20 E3.S server, when multiple drive backplanes are selected, the drive boxes will be populated in the following sequence: 1, 2, 4, 5, and 3.

² Choose either x16 bandwidth for OCP A or x8 bandwidth for both OCP A and OCP B.

Two processors:

Drives	OCP slot	Connection bandwidth	OCP cable option
4 EDSFF stacked drives in Box 5	OCP A	x8 connection	Not required
	OCP B	Up to x16 connection	Required

OCP NICs designed for PCIe x16 can still operate using a x8 connection and achieve maximum throughput with PCIe Gen5 when installed in the rear OCP A slot. For more information on the available OCP NIC options, see the product QuickSpecs (<https://www.hpe.com/info/quickspecs>).

Front OCP NIC 3.0 slots

The front OCP NIC 3.0 slots require the front OCP NIC enablement option kits (Bay 1:P72597-B21, Bay 3: P72596-B21). These slots support OCP NIC options.

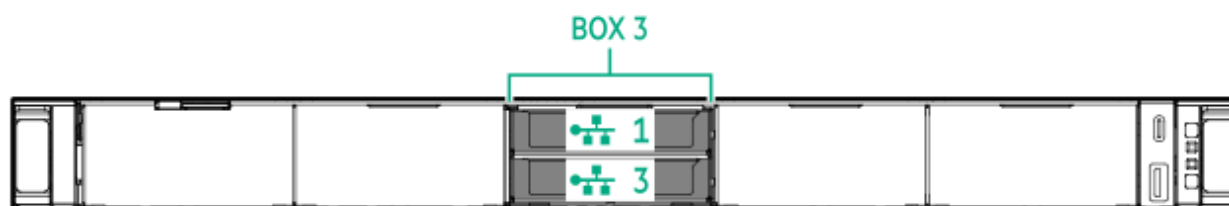

Bay	Slot number
1—Secondary*	Box 3: Bay 1 OCP slot PCIe5 x16
3—Primary	Box 3: Bay 3 OCP slot PCIe5 x16

* The secondary front OCP NIC option requires a dual-processor configuration.

HPE Basic Drive LED definitions

The HPE Basic drive carrier has the following LEDs:

- Amber/blue LED—Managed by the drive backplane in conjunction with the storage controller and is used to indicate drive status.
- Green LED—Managed by the drive itself and indicates the drive activity.

LFF low-profile drive carrier

The LFF low-profile drive carrier supports hot-plug SAS or SATA.

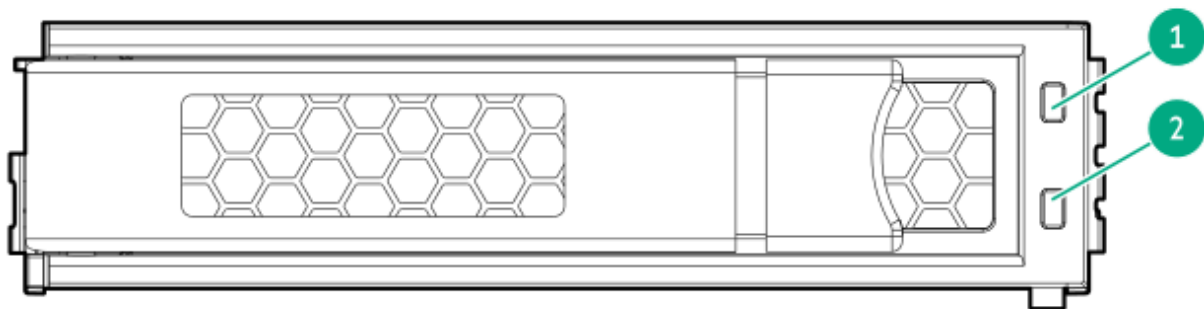

SFF basic drive carrier

The SFF basic drive carrier supports hot-plug U.3 NVMe drives.

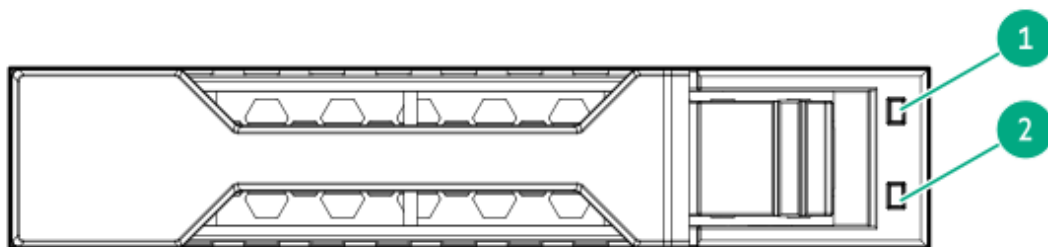

Item	LED	State	Definition
1	Fault/Locate	Solid amber	This drive has failed, is unsupported, or is invalid.
		Solid blue	The drive is operating normally and being identified by a management application.
		Flashing amber/blue (1 flash per second)	The drive has failed, or a predictive failure alert has been received for this drive. The drive has also been identified by a management application.
		Flashing amber (1 flash per second)	A predictive failure alert has been received for this drive. Replace the drive as soon as possible.
		Off	The drive is operating normally and not being identified by a management application.
2	Online/Activity	Solid green	The drive is online and has no activity.
		Flashing green (1 flash per second)	The drive is doing one of the following: <ul style="list-style-type: none"> • Rebuilding or performing a RAID • Performing a stripe size migration • Performing a capacity expansion • Performing a logical drive extension • Erasing • Spare part activation
		Flashing green (4 flashes per second)	The drive is operating normally and has activity.
		Off	The drive is not configured by a RAID controller or is a spare drive.

EDSFF SSD LED definitions

The EDSFF drive carrier has two LEDs:

- Amber/blue LED—Managed by the drive backplane in conjunction with the storage controller and is used to indicate drive status.
- Green LED—Managed by the drive itself and indicates the drive activity.



Item	LED	State	Definition
1	Fault/Locate	Solid amber	This drive has failed, is unsupported, or is invalid.
		Solid blue	The drive is operating normally and being identified by a management application.
		Flashing amber/blue (1 flash per second)	The drive has failed, or a predictive failure alert has been received for this drive. The drive has also been identified by a management application.
		Flashing amber (1 flash per second)	A predictive failure alert has been received for this drive. Replace the drive as soon as possible.
		Off	The drive is operating normally and not being identified by a management application.
2	Online/Activity	Solid green	The drive is online and has no activity.
		Flashing green (4 flashes per second)	The drive is operating normally and has activity.
		Off	No power present.

Fan numbering

The arrow points to the front of the server.

Single processor

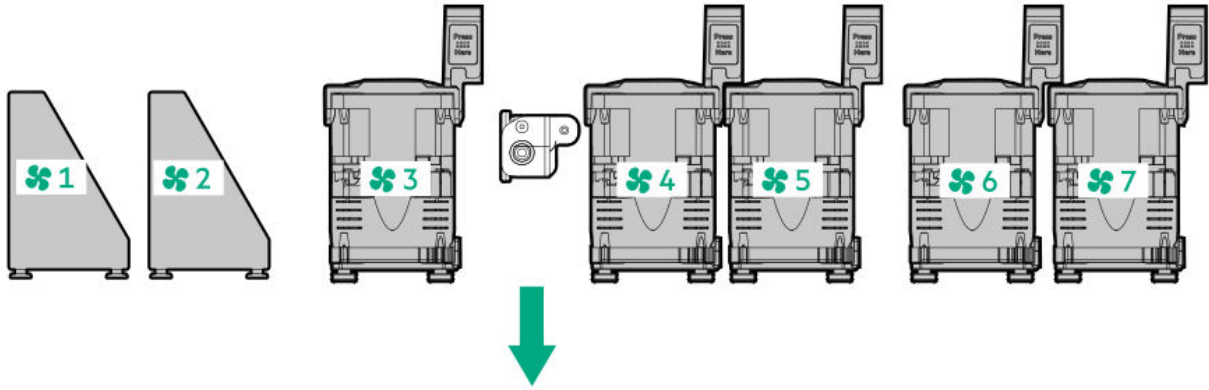

Single or dual processor

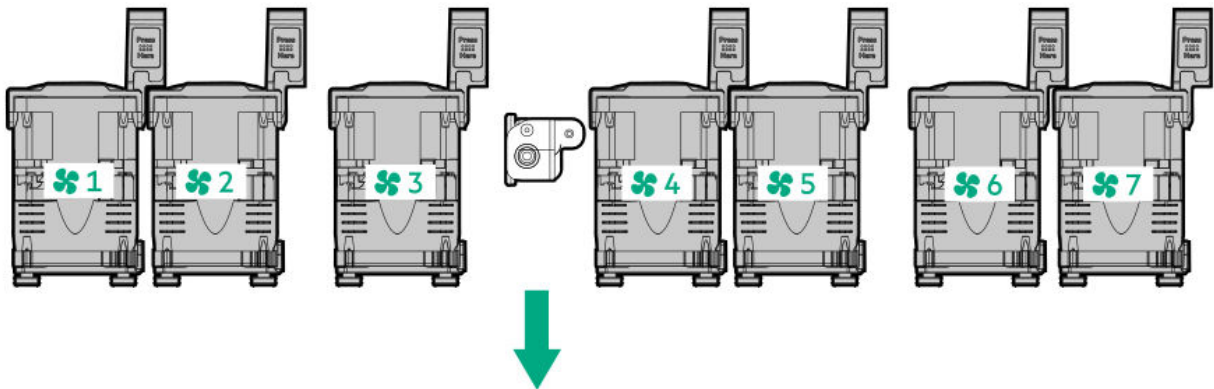

Subtopics

Fan and heatsink requirements

Fan and heatsink requirements

Fan and heatsink type

Processor TDP	Fan type	Heatsink type	Availability
Processor TDP ≤ 185 W	Standard fan	Standard heatsink	Full support
Processor TDP 186–250 W	High performance fan	High performance heatsink ¹	Full support

Processor TDP	Fan type	Heatsink type	Availability
Processor TDP 251–270 W	High performance fan	High performance heatsink ¹	Limited configuration ²
Processor TDP 271–350 W	High performance fan	High performance heatsink ¹	Limited configuration ²
Processor TDP ≤ 270 W (One-processor configuration)	Closed-loop liquid cooling heatsink and fan		Full support
Processor TDP 271–350 W	Closed-loop liquid cooling heatsink and fan		Full support
Processor TDP ≤ 350 W	Direct liquid cooling (DLC) cold plate module (CPM)	DLC fan kit (High performance fan kit)	Full support

- ¹ To support the installation of the optional air baffle, the high performance heatsink must be installed.
- ² For additional information on limited configuration, see the product QuickSpecs on the Hewlett Packard Enterprise website (<https://www.hpe.com/info/quickspecs>).

Some hardware options require a specific fan or heatsink type.

Hardware option	Fan type	Heatsink type
SAS/SATA drives	Standard fan	Standard or high performance heatsink
E3.S / NVMe / SAS4 drives / boot device	High performance fan	Standard or high performance heatsink
¹ 256 GB or higher capacity DIMMs	High performance fan	Standard or high performance heatsink
Type-p Ethernet adapters or type-o InfiniBand adapters ≥ 100 Gb	High performance fan	Standard or high performance heatsink
OCP NIC 3.0 ≥ 100 Gb	High performance fan	Standard or high performance heatsink
GPU cards	High performance fan	Standard or high performance heatsink

- ¹ DIMM blank requirements may vary depending on the hardware configuration. For more information on DIMM blank requirements, see the product QuickSpecs on the Hewlett Packard Enterprise website (<https://www.hpe.com/info/quickspecs>).

Fan population



CAUTION

To avoid damage to server components, fan blanks must be installed in fan bays 1 and 2 in a single-processor configuration.



CAUTION

To avoid damage to the equipment, do not operate the server for extended periods of time if the server does not have the optimal number of fans installed. Although the server might boot, we do not recommend operating the server without the required fans installed and operating.

Air cooling

Processor configuration	Fan bay 1	Fan bay 2	Fan bays 3-7
One-processor configuration	Fan blank	Fan blank	Standard fan
	High performance fan	High performance fan	High performance fan
Dual-processor configuration	Standard fan	Standard fan	Standard fan
	High performance fan	High performance fan	High performance fan

Closed-loop liquid cooling and direct liquid cooling

Cooling component	Fan bays 1-7
Closed-loop liquid cooling heatsink and fan	Liquid cooling fan
Direct liquid cooling kit	High performance fan

The server operates at variable fan speeds. The fans operate at a minimum speed until a temperature change requires the fan speed to increase and cool the server. If a single-rotor fan fails, redundancy is lost. If two single-rotor fans or one dual-rotor fan fails, the server initiates a shutdown. The server shuts down during the following temperature-related scenarios:

- At POST and in the OS, iLO 7 performs an orderly shutdown if a cautionary temperature level is detected. If the server hardware detects a critical temperature level before an orderly shutdown occurs, the server performs an immediate shutdown.
- When the Thermal Shutdown feature is disabled in the BIOS/Platform Configuration (RBSU), iLO 7 does not perform an orderly shutdown when a cautionary temperature level is detected. Disabling this

feature does not disable the server hardware from performing an immediate shutdown when a critical temperature level is detected.



CAUTION

A thermal event can damage server components when the Thermal Shutdown feature is disabled in the BIOS/Platform Configuration (RBSU).

High performance fans are required for ASHRAE-compliant configurations. For more information on ASHRAE, see the Hewlett Packard Enterprise website (<https://www.hpe.com/support/ASHRAEGen12>).

Heatsink and processor socket components

A high performance heatsink is shown. Your heatsink might look different.



Item	Description
1	Processor-heatsink module ¹
2	Heatsink nuts
3	Heatsink latches
4	Processor carrier latches
5	Alignment screws
6	Bolster plate

¹ This module consists of the heatsink attached to the processor that is already secured in its carrier.

Closed-loop liquid cooling (CLLC) module components

For more information, see [Liquid cooling guidelines](#).

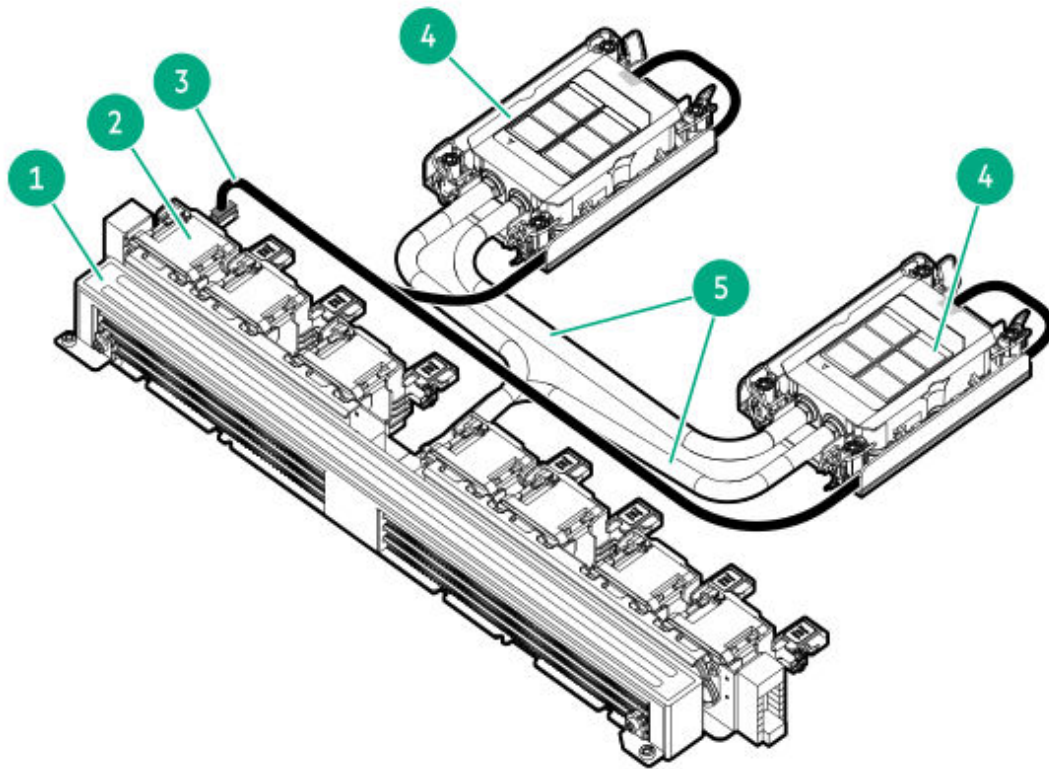

Item	Description
1	Radiator
2	Fans
3	Power and signal cable
4	Cold plates and pumps ¹
5	Coolant hoses
6	Leak detection cable ²

¹ Each of the closed-loop liquid cooling cold plates has two pumps for redundancy.

² Not shown

Liquid cooling guidelines

The closed-loop liquid cooling (CLLC) module hoses are prefilled with coolant. The coolant is a mixture of purified water and ethylene glycol with additional corrosion-resistant additives. The direct liquid cooling (DLC) module coolant is fed into the hoses through the rack manifolds.

CLLC module lifespan

HPE recommends replacing the module every five years. The coolant anti-corrosion additives degrade over time resulting in potential leaks in the system. For additional information on protecting the system, contact your local HPE representative.

Coolant leakage detection

If a liquid cooling module coolant leakage occurs, the following happens:

- iLO automatically detects it and:
 - Sends an iLO REST alert and Simple Network Management Protocol (SNMP) trap
 - Records the event in the Integrated Management Log (IML)
- The system initiates an immediate shutdown. The system will not power on until the leakage event is cleared, and a REST API operation for system recovery is performed.
- Follow the recommended procedure in Appendix I: Server coolant spill response of the server maintenance guide.

Do not attempt to replace the coolant in the CLLC module. For service inquiries, contact your local service provider.

Storage temperature

When storing a server with a liquid cooling module, maintain a temperature of -10°C to 60°C (14°F to 140°F). Allowing the liquid cooling module coolant to freeze can damage its metallic microstructures.

Facility water supply temperature

To maintain optimal cooling performance and prevent equipment damage from overheating:

- Do not allow the facility water supply temperature to exceed 40°C (104°F).
- Monitor environmental conditions year-round to anticipate temperature fluctuations.
- Install insulated plumbing as needed to ensure the water supply remains at or below 40°C (104°F).

HPE NS204i-u Boot Device V2 components

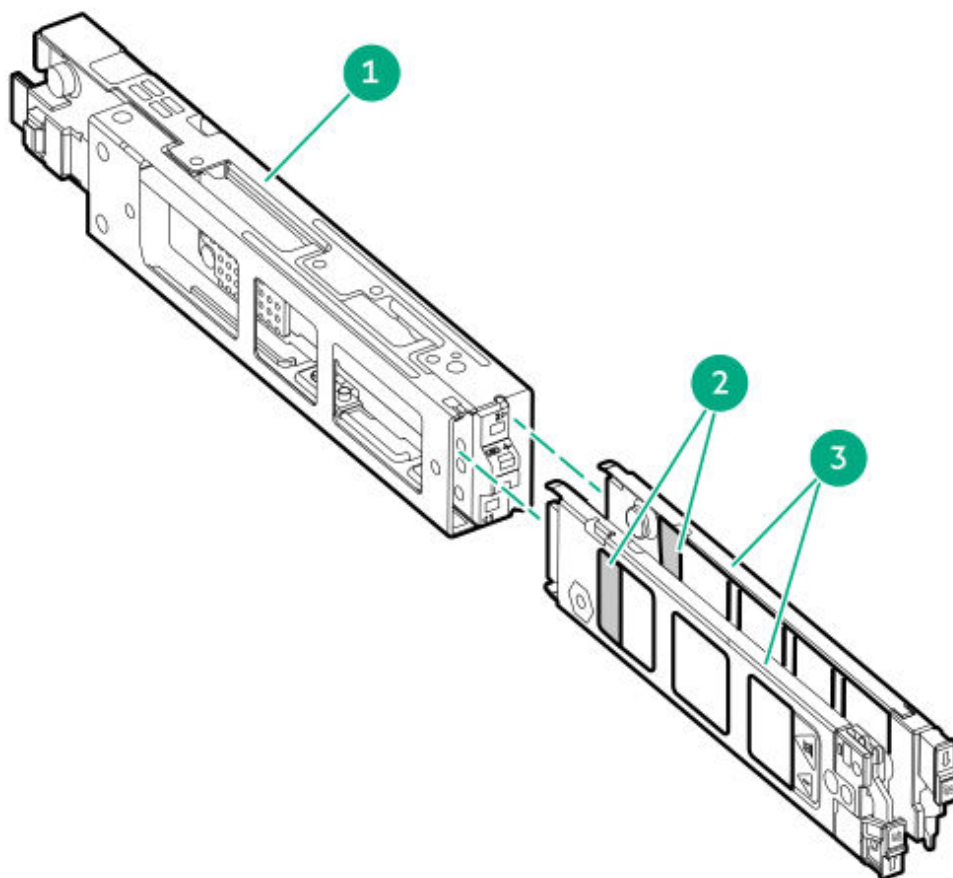

Item	Description
1	Boot device cage
2	M.2 slots
3	Boot device carriers

HPE NS204i-u Boot Device V2 LED definitions

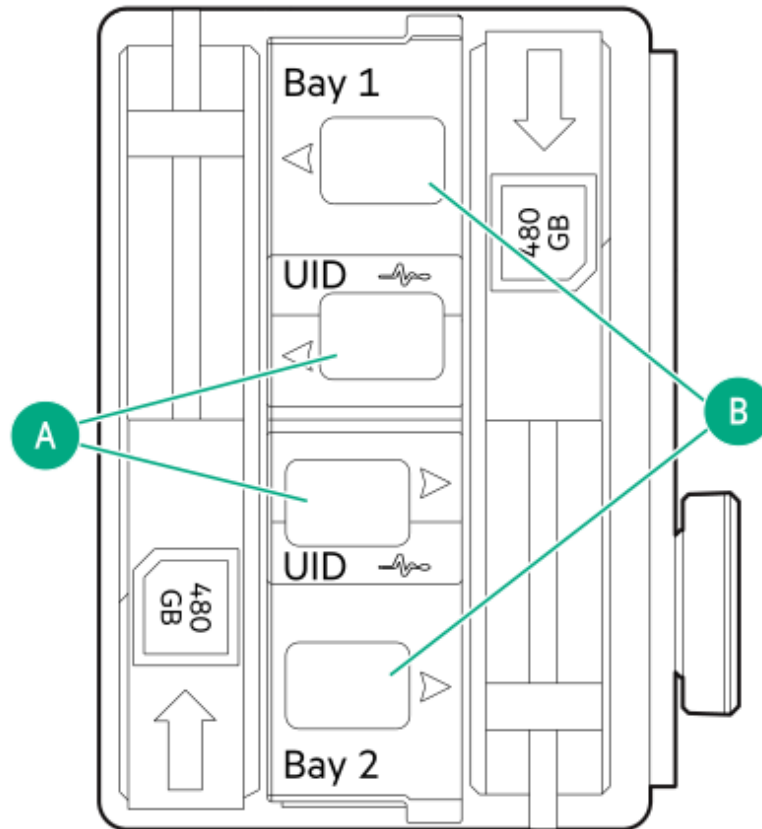

NOTE

The bay number can be found on the SSD carrier handle.

Item	LED	Status	Definition
A	Fault or Locate	Solid amber	Drive has failed, unsupported, or invalid.
		Solid blue	Drive is operating normally.
		Flashing amber or blue (one flash per second)	Drive has failed, or a predictive failure alert is received for the drive.
		Flashing amber (one flash per second)	Drive predictive failure alert is received. Replace the drive as soon as possible.
		Off	Drive is operating normally and is not identified by any application.
B	Online/Activity	Solid green	Drive is online and has no activity.

Item	LED	Status	Definition
		Flashing green (one flash per second)	Drive is doing one of the following: <ul style="list-style-type: none"> Rebuilding or performing a RAID Erasing
		Flashing green (4 flashes per second)	Drive is operating normally and has activity.
		Off	Drive is not configured by a RAID controller.

Riser board components

All riser slots are PCIe5 x16 (16, 8, 4, 1) and are rated for a maximum power draw of 75 W each.

Primary riser

This riser board supports Slots 1 and 2 in the three-slot configuration, or Slot 1 in the two-full-height slot configuration.

- Front: Slot 1

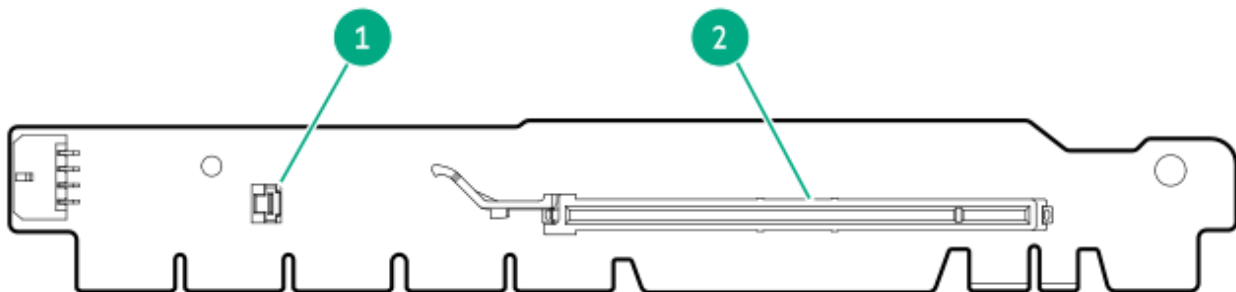

Item	Description	Supported form factors
1	Controller storage backup power connector	—
2	PCIe5 x16 (16, 8, 4, 1)	Full-height, up to 9.5" (or half-length)

- Back: Slot 2 in the three-slot configuration

This slot is not supported in the two-full-height-slot configuration.



Item	Description	Supported form factors
1	PCIe5 x16 (16, 8, 4, 1)	Half-height, half-length (low-profile)*
2	Controller storage backup power connector	—

Secondary full-height riser

This riser board supports Slot 3 in the two-full-height-slot configuration, and is included in the secondary x16 full-height riser kit (P72598-B21).

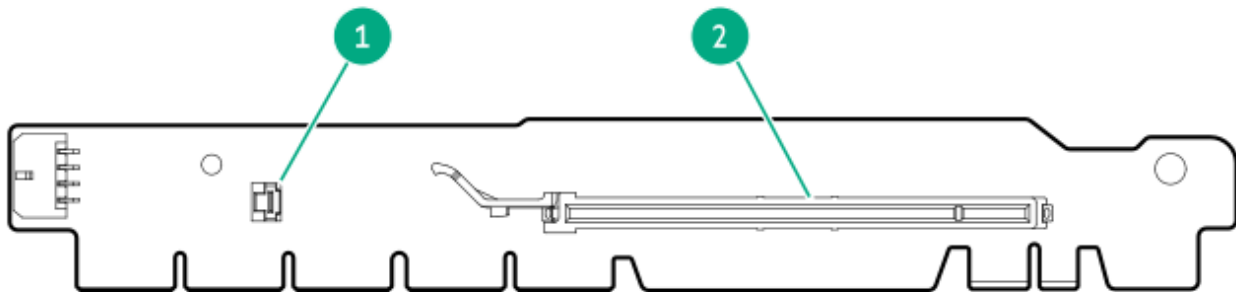

Item	Description	Supported form factors
1	Controller storage backup power connector	—
2	PCIe5 x16 (16, 8, 4, 1)	Full-height, up to 9.5" (or half-length)

Secondary low-profile riser

This riser board supports Slot 3 in the three-slot configuration, and is included in the secondary x16 low-profile riser kit (P48903-B21).

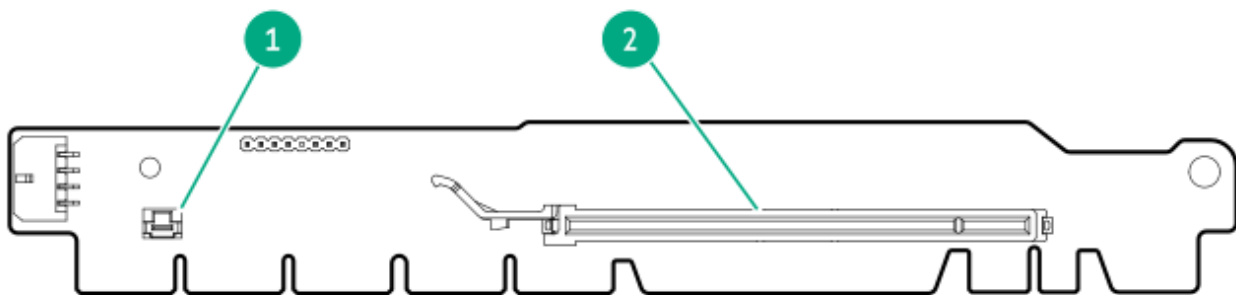

Item	Description	Supported form factors
1	Controller storage backup power connector	—
2	PCIe5 x16 (16, 8, 4, 1)	Half-height, half-length (low-profile)

Riser slot numbering

Slot 3 requires the secondary processor.

Three-slot configuration



Two-full-height-slot configuration



Troubleshooting

Subtopics

[NMI functionality](#)

[Front panel LED power fault codes](#)

[Troubleshooting resources](#)

NMI functionality

An NMI crash dump enables administrators to create crash dump files when a system is not responding to traditional debugging methods.

An analysis of the crash dump log is an essential part of diagnosing reliability problems, such as hanging operating systems, device drivers, and applications. Many crashes freeze a system, and the only available action for administrators is to cycle the system power. Resetting the system erases any information that could support problem analysis, but the NMI feature preserves that information by performing a memory dump before a hard reset.

To force the OS to initiate the NMI handler and generate a crash dump log, the administrator can use the iLO Generate NMI feature.

Front panel LED power fault codes

The following table provides a list of power fault codes, and the subsystems that are affected. Not all power faults are used by all servers.

Subsystem	LED behavior
System board	1 flash
Processor	2 flashes
Memory	3 flashes
Riser board PCIe slots	4 flashes
OCP adapter	5 flashes
Storage controller	6 flashes
System board PCIe slots	7 flashes
Power backplane	8 flashes
Storage backplane	9 flashes
Power supply	10 flashes
PCIe expansion cards installed in riser board	11 flashes
Chassis	12 flashes
GPU card	13 flashes

Troubleshooting resources

If you need help troubleshooting, see the latest articles for your server.

<https://www.hpe.com/info/dl360gen12-troubleshooting>

Cabling guidelines

Observe the following:



NOTE

The colors in the cabling diagrams are for illustration purposes only.



CAUTION

To avoid damaging connectors, avoid repeated installation and removal of cables. Excessive handling can shorten the lifespan of the cable.

- For cable option kits, see the product QuickSpecs.
- For cable spare part numbers, see the Illustrated parts catalog in the maintenance and service guide.
- Some diagrams show alphabetical callouts such as A, B, C, etc. These callouts correspond to labels near the connectors on the cable.
- Some cables have more than one connector, such as a Y-cable, but not all connectors are used.
- Observe all guidelines when working with server cables.

Before connecting cables

- Note the port labels on the PCA components. Not all these components are used by all servers:
 - System board ports
 - Drive and power supply backplane ports
 - Expansion board ports (controllers, retimers, adapters, expanders, risers, and similar boards)
- Note the label near each cable connector. This label indicates the destination port for the cable connector.
- Some data cables are prebent. Do not unbend or manipulate the cables.

- To prevent mechanical damage or depositing oil that is present on your hands, and other contamination, do not touch the ends of the connectors.

When connecting cables

- Before connecting a cable to a port, lay the cable in place to verify the length of the cable.
- Use the internal cable management features to properly route and secure the cables.
- Route cables so that they do not contact or rest on cooling components, including heatsinks. Ensure that cable routing does not obstruct airflow to or from heatsinks or ventilation openings
- When routing cables, be sure that the cables are not in a position where they can be pinched or crimped.
- Avoid tight bend radii to prevent damaging the internal wires of a power cord or a server cable. Never bend power cords and server cables tight enough to cause a crease in the sheathing.
- Make sure that the excess length of cables is properly secured to avoid excess bends, interference issues, and airflow restriction.
- Before installing a new component or closing up the server, make sure that all cables are in their appropriate routing position. This cable check prevents component damage and potential signal interference.

When disconnecting cables

- Grip the body of the cable connector. Do not pull on the cable itself because this action can damage the internal wires of the cable or the pins on the port.

- If a cable does not disconnect easily, check for any release latch that must be pressed to disconnect the cable.

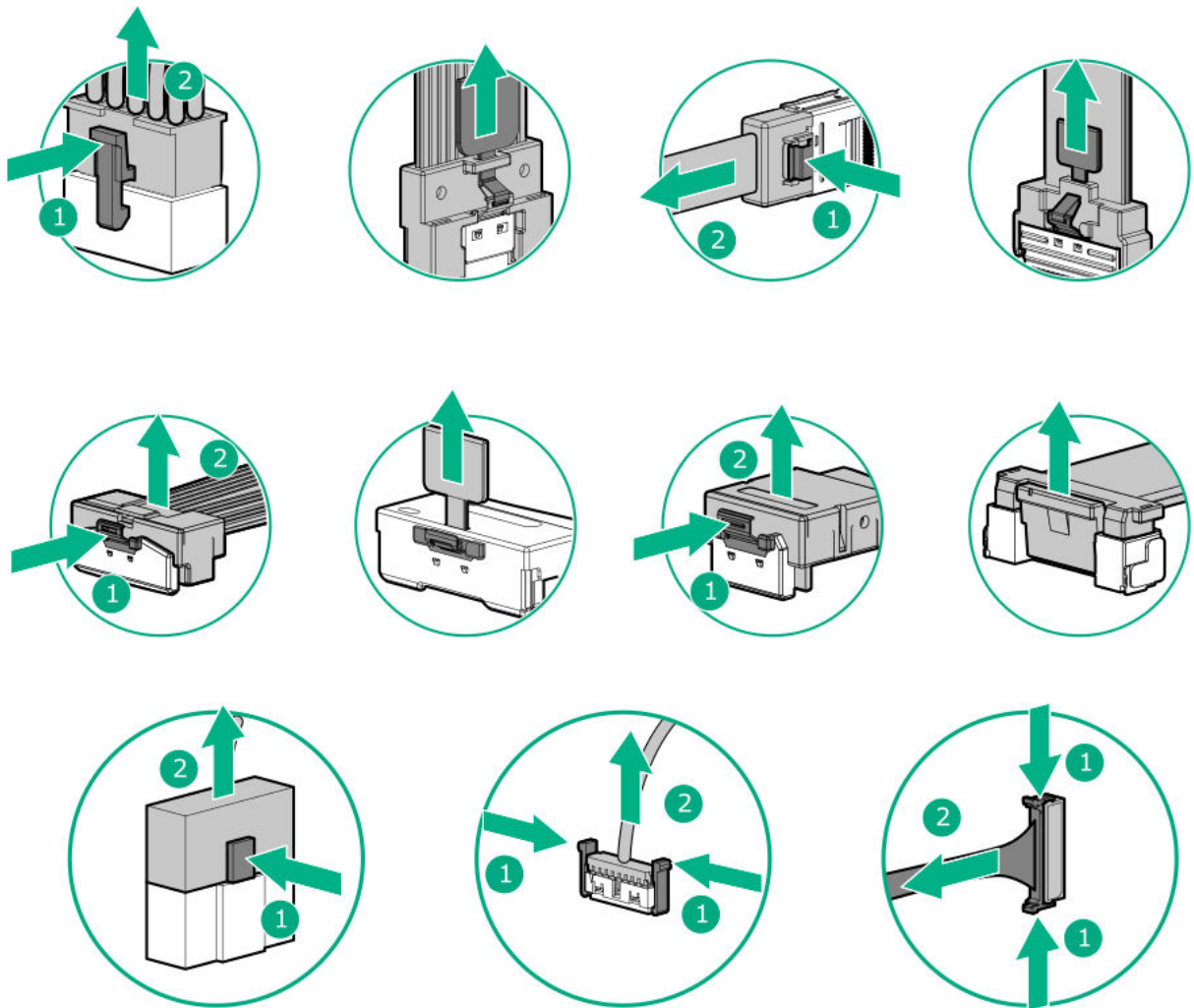

- Remove cables that are no longer being used. Retaining them inside the server can restrict airflow. If you intend to use the removed cables later, label and store them for future use.

Cabling diagrams

Observe the following:

- Before cabling components, see the [Cabling guidelines](#).
- Use the cable part number or search feature to find your diagram.

Component cabling	Cable part number
Storage controller cabling: 4 LFF drive configuration	—
4 LFF controller cable: type-p controller in the primary riser	P48970-001
4 LFF controller cable: type-o controller in Slot 14 OCP A	P48958-001
Storage controller cabling: 8 SFF drive configuration	—
8 SFF Box 1 x1 NVMe controller cable: type-o controller in Slot 14 OCP A	P48960-001
8 SFF Box 1 x1 NVMe controller cable: type-p controller in the primary riser	P45610-001
8 SFF Box 1 x1 NVMe controller cable: type-p controller in the primary riser	P79151-001 ¹
Storage controller cabling: 8 + 2 SFF drive configuration	—
8 SFF + 2 SFF x4 NVMe controller cables: type-o controller in Slot 14 OCP A	P48960-001 P48962-001
8 SFF + 2 SFF x4 NVMe controller cables: type-o controller in Slot 15 OCP B	P55357-001 P48961-001
8 SFF x1 NVMe + 2 SFF NVMe controller cables: type-p controller in Slot 1	P45610-001 P45611-001
8 SFF x1 NVMe to type-o controller in Slot 14 OCP A + 2 SFF x4 direct attach	P48960-001 P75946-001
8 SFF x1 NVMe to type-o controller + 2 SFF NVMe to type-p controller	P48960-001 P45611-001
8 SFF x1 NVMe to Slot 1 type-p controller + 2 SFF x4 NVMe to type-o controller in Slot 14 OCP A	P45610-001 P48962-001
8 SFF x1 NVMe to Slot 1 type-p controller + 2 SFF direct attach	P45610-001 P75946-001
8 SFF x1 NVMe to type-o controller in Slot 15 OCP B + 2 SFF to type-p controller in Slot 2	P55357-001 P45611-001

Component cabling	Cable part number
8 SFF x1 NVMe to type-o controller in Slot 15 OCP B + 2 SFF x4 NVMe direct attach	P55357-001 P75946-001
8 SFF x1 NVMe to type-o controller in Slot 15 OCP B + 2 SFF x4 NVMe to type-o controller in Slot 14 OCP A	P55357-001 P48962-001
8 SFF x1 NVMe + 2 SFF x4 NVMe to type-p controller in Slot 2	P45610-001 P45611-001
8 SFF x1 NVMe to type-o controller in Slot 14 OCP A + 2 SFF x4 NVMe to type-o controller in Slot 15 OCP B	P48960-001 P48961-001
8 SFF x1 NVMe to type-o controller in Slot 14 OCP A + 2 SFF x4 NVMe to Slot 2 type-p controller	P48960-001 P45611-001
8 SFF x1 NVMe + 2 SFF x4 NVMe to type-p controller in Slot 1	P79151-001 ¹ / _— P76443-001 ¹ / _—
8 SFF x1 NVMe to type-o controller + 2 SFF x4 NVMe to type-p controller in Slot 1	P48960-001 ¹ / _— P76443-001 ¹ / _—
8 SFF x1 NVMe to type-p controller in Slot 1 + 2 SFF x4 NVMe to type-o controller	P79151-001 ¹ / _— P48962-001 ¹ / _—
Storage controller cabling: 4 EDSFF stacked in the 10 SFF / 20 E3.S server —	
4 EDSFF Box 1: direct attach cable (unbalanced, 1 CPU)	P75568-001
4 EDSFF Box 1: direct attach cable (unbalanced)	P75568-001 P75278-001
4 EDSFF Box 1: secondary riser type-p controller cable	P74805-001
4 EDSFF Box 2: direct attach cable (unbalanced, 1 CPU)	P75567-001
4 EDSFF Box 2: direct attach cable (unbalanced)	P75317-001
4 EDSFF Box 3 x4 NVMe: direct attach cable	P75278-001
4 EDSFF Box 4 x4 NVMe: direct attach cable	P74806-001 P75278-001

Component cabling	Cable part number
4 EDSFF Box 4 x4 NVMe: type-p controller in Slot 1	<u>P75590-001</u>
4 EDSFF Box 4 x4 NVMe: type-p controller in Slot 2	<u>P75590-001</u>
4 EDSFF Box 5 x4 NVMe: direct attach cable	<u>P75278-001</u> <u>P75567-001</u>
4 EDSFF Box 5 x4 NVMe: type-p controller in Slot 1	<u>P76443-001</u> <u>P75574-001</u>
4 EDSFF Box 5 x4 NVMe: type-p controller in Slot 2	<u>P76443-001</u> <u>P75574-001</u>
4 EDSFF Box 5 x4 NVMe: type-o controller cable (CPU1 and CPU2)	<u>P75589-001</u>
8 EDSFF Boxes 1–2 x4: direct attach cable	<u>P75568-001</u> <u>P75278-001</u> <u>P75317-001</u>
8 EDSFF Boxes 1–2 x4 NVMe to type-p controller in Slot 1 (1 CPU)	<u>P75318-001</u> <u>1</u>
8 EDSFF Boxes 1–2 x4 NVMe to type-p controller in Slot 3	<u>P75318-001</u> <u>1</u>
8 EDSFF Boxes 4–5 x4 NVMe to type-p controller in Slot 1	<u>P75570-001</u> <u>1</u> <u>P75569-001</u> <u>1</u>
8 EDSFF Boxes 1 and 4 x4 NVMe to type-p controller in Slot 1 (1 CPU)	<u>P75570-001</u> <u>1</u> <u>P75318-001</u> <u>1</u>
8 EDSFF Boxes 1 and 5 x4 NVMe to type-p controller in Slot 1 (1 CPU)	<u>P75318-001</u> <u>1</u> <u>P75570-001</u> <u>1</u> <u>P75569-001</u> <u>1</u>
Storage controller cabling: 2 SFF stacked in the 10 SFF / 20 E3.S server	—
2 SFF Box 1 x4 NVMe: direct attach cable (1 CPU)	<u>P75568-001</u>
2 SFF Box 1 x4 NVMe: type-p controller in Slot 1	<u>P75590-001</u>
2 SFF Box 1 x4 NVMe: direct attach cable	<u>P75317-001</u>
2 SFF Box 1 x4 NVMe: type-p controller in Slot 3	<u>P75590-001</u>
2 SFF Box 2 x4 NVMe: direct attach cable (1 CPU)	<u>P75568-001</u>

Component cabling	Cable part number
2 SFF Box 2 x4 NVMe: direct attach cable (CPU1 and CPU 2)	<u>P75278-001</u>
2 SFF Box 2 x4 NVMe: type-p controller in Slot 1	<u>P75590-001</u>
2 SFF Box 2 x4 NVMe: type-p controller in Slot 3	<u>P75590-001</u>
2 SFF Box 3 x4 NVMe: direct attach (1 CPU)	<u>P75278-001</u>
2 SFF Box 3 x4 NVMe: direct attach (1 CPU and supporting OCP B)	<u>P75567-001</u>
2 SFF Box 3 x4 NVMe: type-o controller in Slot 14 OCP A (1 CPU)	<u>P75589-001</u>
2 SFF Box 3 x4 NVMe: type-o controller in Slot 15 OCP B	<u>P75587-001</u>
2 SFF Box 3 x4 NVMe: type-p controller in the primary riser	<u>P75590-001</u>
2 SFF Box 4 x4 NVMe: direct attach cable (1 CPU)	<u>P75317-001</u>
2 SFF Box 4 x4 NVMe: direct attach cable	<u>P75567-001</u>
2 SFF Box 4 x4 NVMe: type-o controller in Slot 14 OCP A	<u>P75589-001</u>
2 SFF Box 4 x4: type-o controller in Slot 15 OCP B	<u>P75589-001</u>
2 SFF Box 4 x4 NVMe: type-p controller in Slot 1	<u>P76443-001</u>
2 SFF Box 4 x4 NVMe: type-p controller in Slot 2	<u>P76443-001</u>
2 SFF Box 5 x4 NVMe: direct attach cable (1 CPU)	<u>P75567-001</u>
2 SFF Box 5 x4 NVMe: direct attach cable (1 CPU and supporting OCP B)	
2 SFF Box 5 x4 NVMe: type-p controller in Slot 2 (1 CPU and supporting OCP B)	<u>P75590-001</u>
2 SFF Box 5 x4: type-o controller in Slot 14 OCP A	<u>P75589-001</u>
2 SFF Box 5 x4: type-o controller in Slot 15 OCP B	
2 SFF Box 5 x4 NVMe: type-p controller in Slot 1	<u>P76443-001</u>
2 SFF Box 5 x4 NVMe: type-p controller in Slot 2	<u>P76443-001</u>
2 SFF Box 5 x4 NVMe: type-o controller cable	<u>P75589-001</u>
4 SFF Boxes 1-2 x4 (x2 BW) NVMe: type-p controller in Slot 1	<u>P75593-001</u>
2 SFF Boxes 1-2 x4 (x2 BW) NVMe: type-p controller in Slot 2	<u>P75593-001</u>
4 SFF Boxes 1-2 (x2 BW) NVMe: type-o controller in Slot 14 OCP A	<u>P75571-001</u>
4 SFF Boxes 1-2 x4 (x2 BW) NVMe: type-o controller in Slot 14 OCP A	<u>P75571-001</u>

Component cabling	Cable part number
4 SFF Boxes 1–2 x4 (x2 BW) NVMe: type-o controller in Slot 1 of 15 OCP B	P75573-001
4 SFF Boxes 1–2 x4 NVMe to type-p controller in Slot 1	P75318-001 ¹ / _—
4 SFF Boxes 4–5 x4 NVMe: direct attach cables	P75567-001 P75278-001
4 SFF Boxes 4–5 x4 (x2 BW) NVMe: type-o controller in Slot 1 of 14 OCP A	P75573-001
4 SFF Boxes 4–5 x4 (x2 BW) NVMe: type-o controller in Slot 1 of 15 OCP B	P75571-001
4 SFF Boxes 4–5 x4: type-o controller in Slot 15 OCP B	P75589-001
4 SFF Boxes 4–5 x4 (x2 BW) NVMe: type-p controller in Slot 1 of 1	P75572-001
4 SFF Boxes 4–5 x4 (x2 BW) NVMe: type-p controller in Slot 1 of 2	P75572-001
4 SFF Boxes 4–5 x4 NVMe to type-p controller in Slot 1	P75570-001 ¹ / _—
10 SFF Boxes 1–5 NVMe: type-p controller in Slot 1	P79152-001 ¹ / _— P79153-001 ¹ / _— P75275-001 ¹ / _—
Power cabling	—
4 LFF backplane power cable	P75565-001
8 SFF backplane power cable	P75566-001
2 SFF backplane power cable	869667-001
Stacked SFF / EDSFF backplane power cable in the 10 SFF / 20 E3.S server	P75316-001
Storage backup power cable	—
Energy pack cabling	—
Energy pack extension power cable	P45618-001
Optical drive cabling	—
Optical drive cable in the 4 LFF, 8 SFF, or 10 SFF / 20 E3.S server	P73776-002
Front I/O cabling	—
Front DisplayPort / USB cable in the 4 LFF, 8 SFF, or 10 SF F / 20 E3.S server	P73948-001
HPE NS204i-u Boot Device V2 cabling	—

Component cabling	Cable part number
HPE NS204i-u Boot Device V2 power cable	P48956-001
HPE NS204i-u Boot Device V2 signal cable	P74839-001
Riser cage HPE NS204i-u Boot Device V2 power cable	P54088-001
Riser cage HPE NS204i-u Boot Device V2 signal cable	P71913-001
OCP bandwidth enablement cabling	—
Slot 14 OCP A x16 enablement cable	P74890-001
CPU1 to Slot 15 OCP B x8 enablement cable	P74889-001
CPU2 to Slot 15 OCP B x8 / x16 enablement cable	P74891-001
Font OCP enablement cabling	—
Front OCP Bay 1 / 3 cable	P71942-001
Phy board cable	P73927-001
Miscellaneous component cabling	—
Serial port cable	P45623-001
Chassis intrusion detection switch cable	P47751-001
Front I/O cable (included in the right chassis ear assembly)	P71909-002
System Insight Display cable	P48971-001
Liquid cooling module cable	—

¹ This configuration uses the controller cable with the MR932i-p storage controller.

Internal cabling management

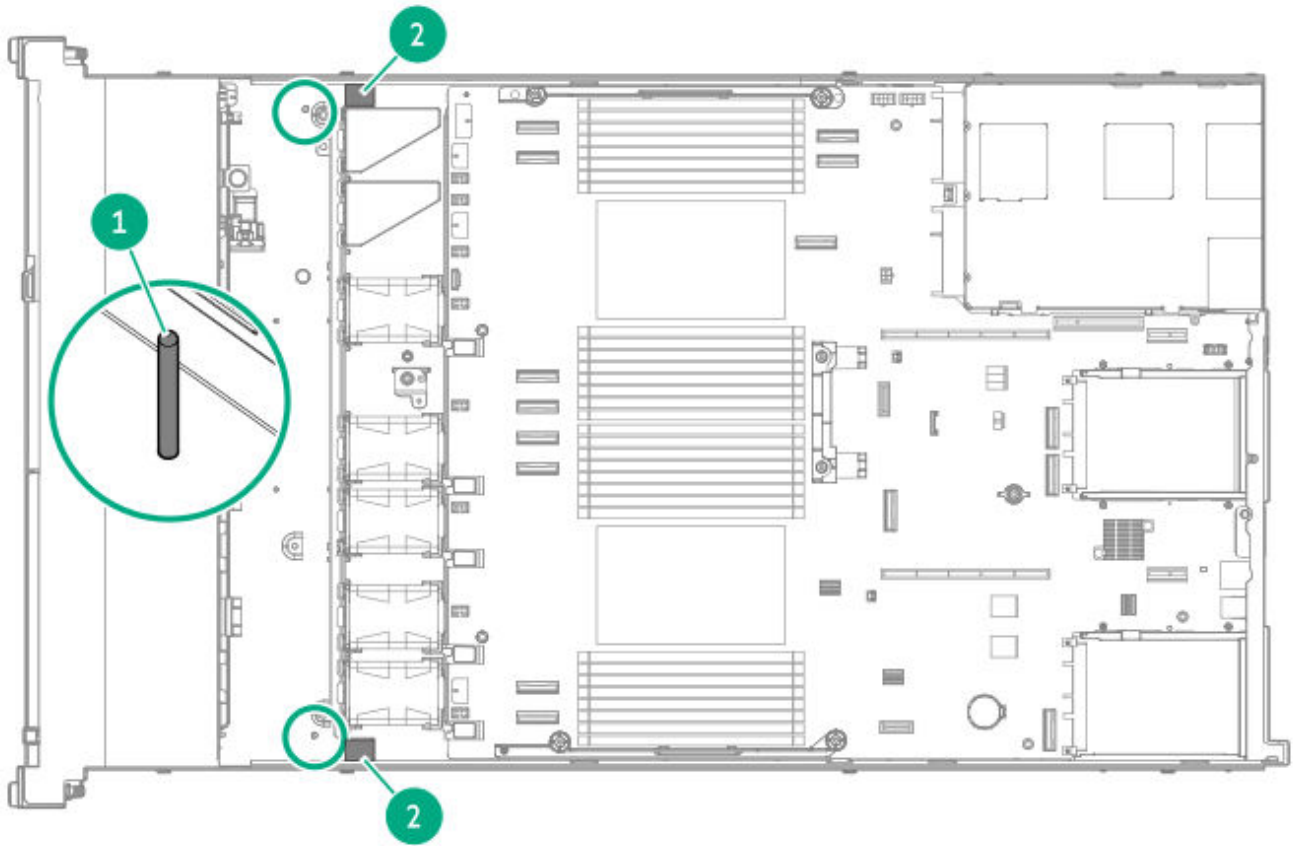

Item	Description
1	Cable routing posts
2	Cable routing foams

Storage cabling

Subtopics

- [4 LFF drive backplane cabling](#)
- [8 SFF drive backplane cabling](#)
- [8 + 2 SFF drive backplane cabling](#)
- [4 E3.S stacked drive backplane cabling](#)
- [2 SFF stacked drive backplane cabling](#)
- [Storage controller backup power cabling](#)

4 LFF drive backplane cabling

4 LFF Box 1: type-p controller in the primary riser



Cable part number	Color	From	To
P48970-001	Orange	Drive backplane	Slot 1 type-p controller Port 1i

4 LFF Box 1: type-o controller in Slot 14 OCP A

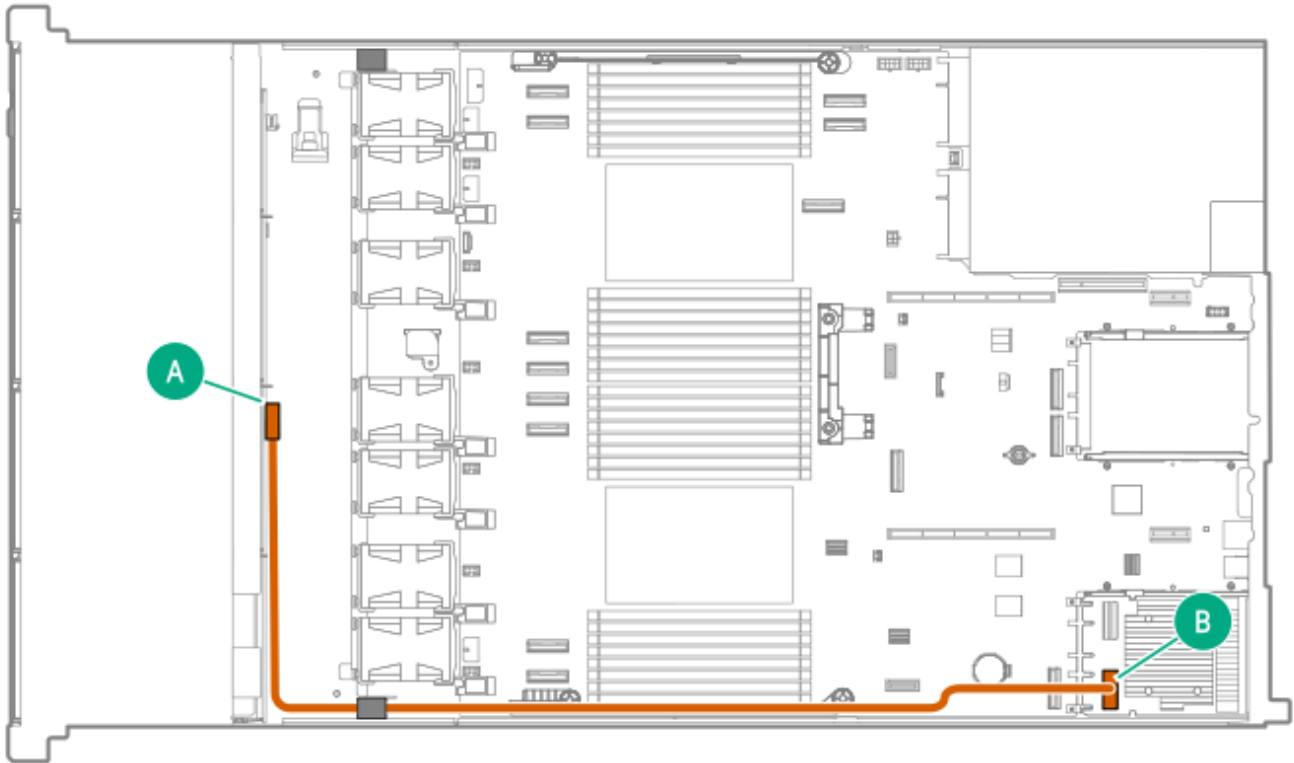

Cable part number	Color	From	To
P48958-001	Orange	Drive backplane	Slot 14 OCP A type-o controller Port 1i

8 SFF drive backplane cabling

8 SFF Box 1 x1 NVMe controller cabling: type-o controller in Slot 14 OCP A

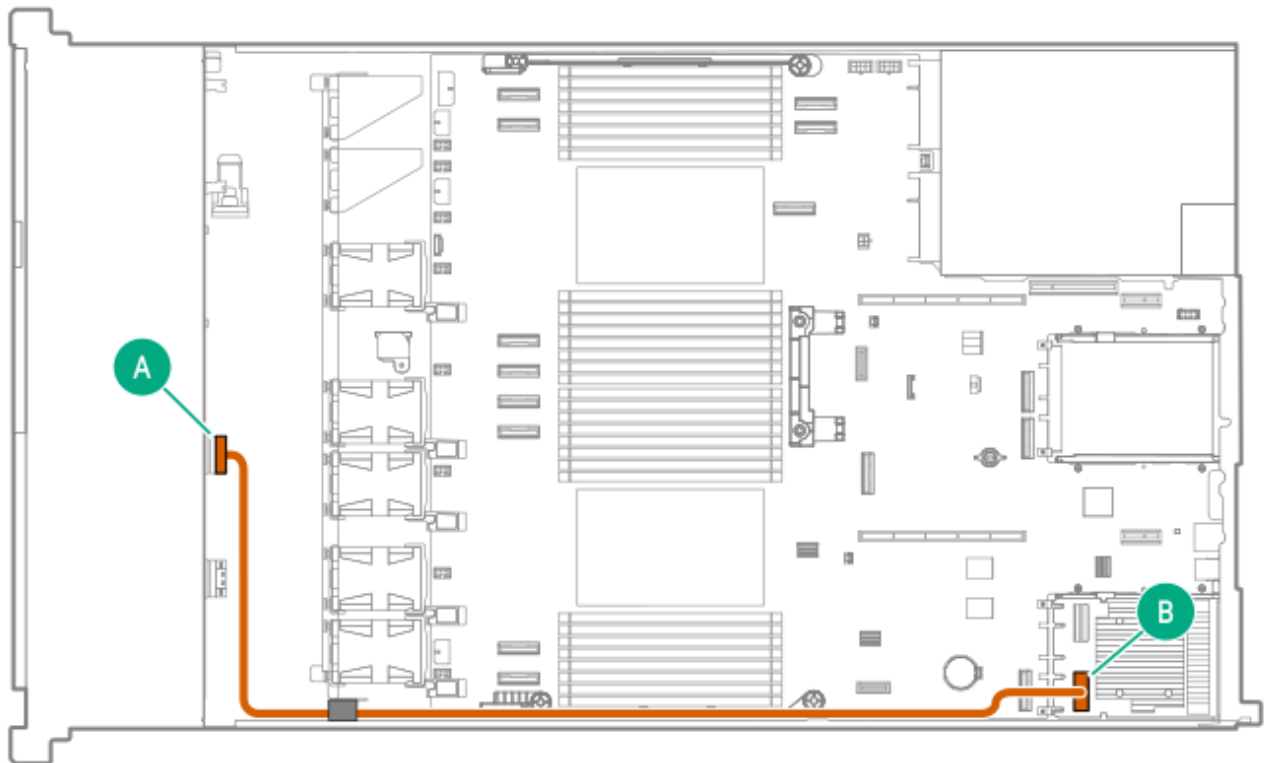

Cable part number	Color	From	To
P48960-001	Orange	Drive backplane	Slot 14 OCP A type-o controller Port 1i

8 SFF Box 1 x1 NVMe controller cabling: type-p controller in the primary riser

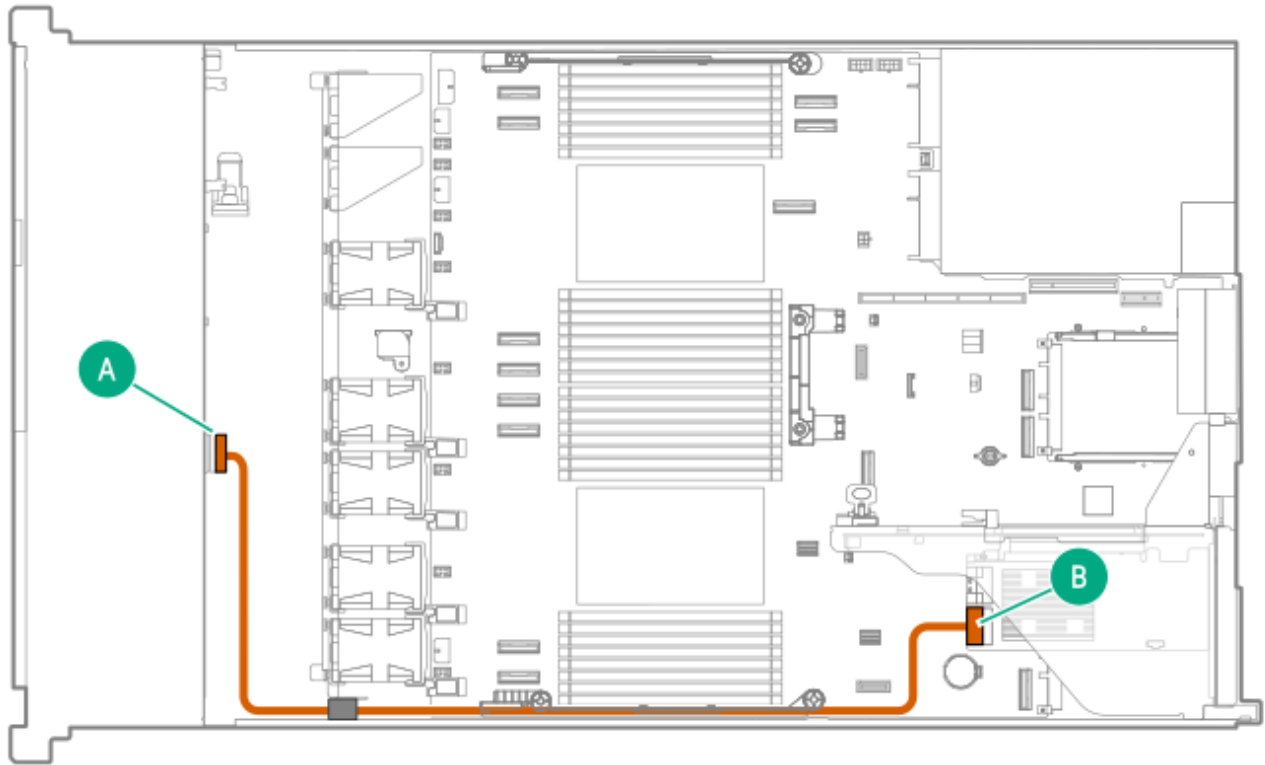

Cable part number	Color	From	To
P45610-001	Orange	Drive backplane	Primary type-p controller Port 1i

8 SFF Box 1 x1 NVMe controller cabling: type-p controller in the primary riser

MR932i-p:

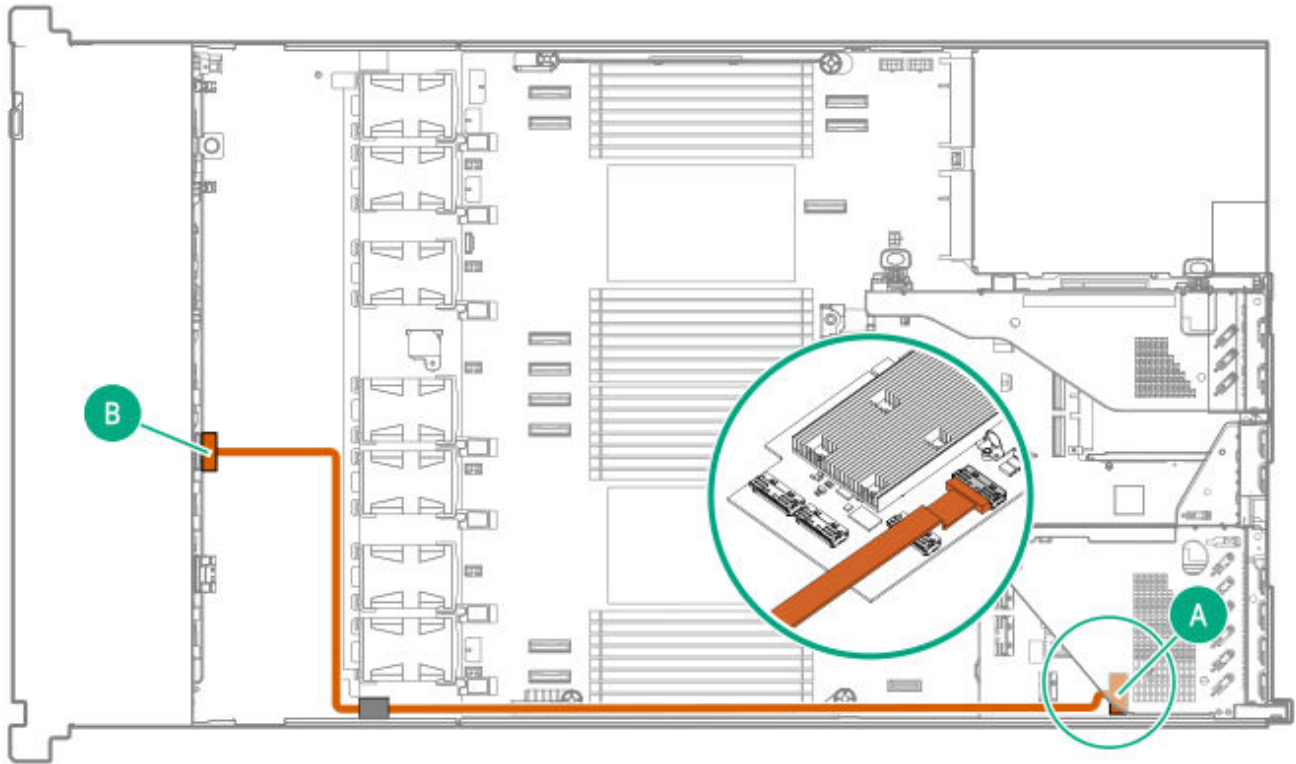

Cable part number	Color	From	To
P79151-001	Orange	Drive backplane	Primary type-p controller Port 3i

8 + 2 SFF drive backplane cabling

8 SFF x1 NVMe + 2 SFF x4 NVMe controller cabling: type-o controller in Slot 14 OCP A

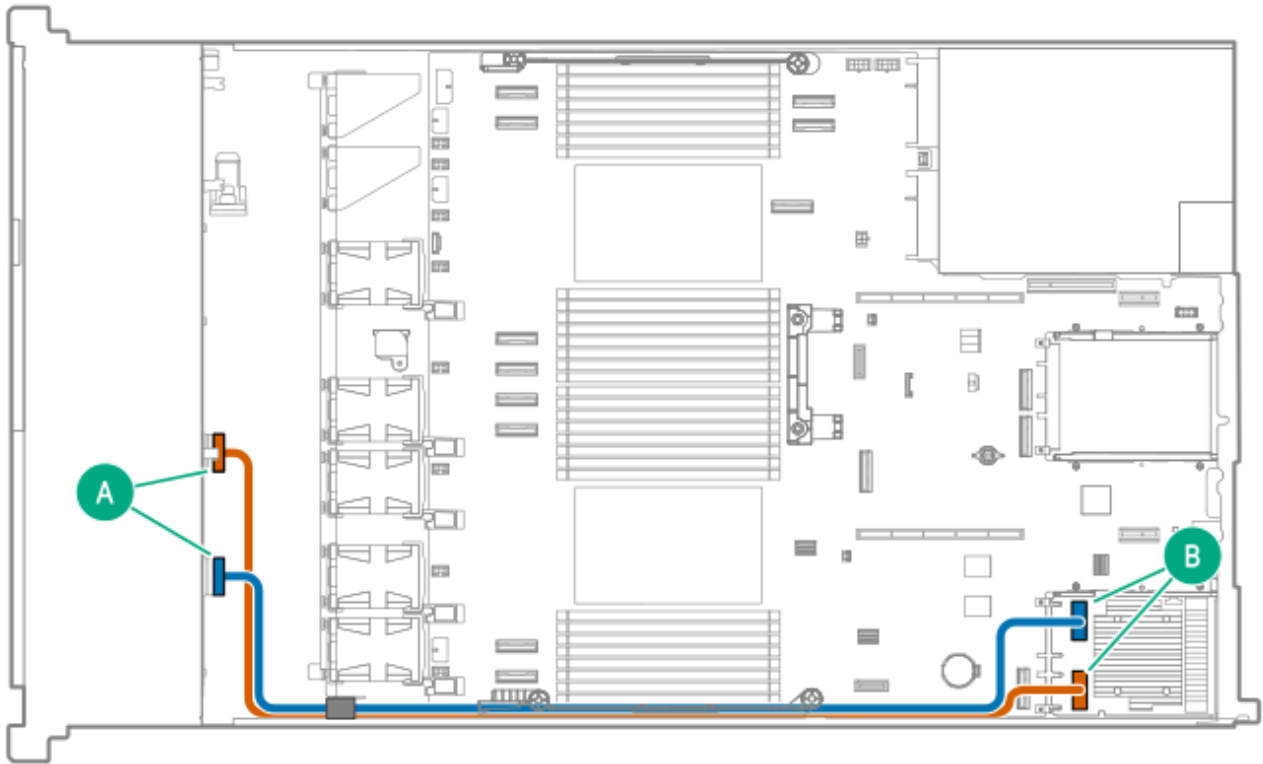

Cable part number	Color	From	To
P48960-001	Orange	8 SFF drive backplane	Slot 14 OCP A type-o controller Port 1i
P48962-001	Blue	2 SFF drive backplane	Slot 14 OCP A type-o controller Port 2i

8 SFF x1 NVMe + 2 SFF x4 NVMe controller cabling: type-o controller in Slot 15 OCP B

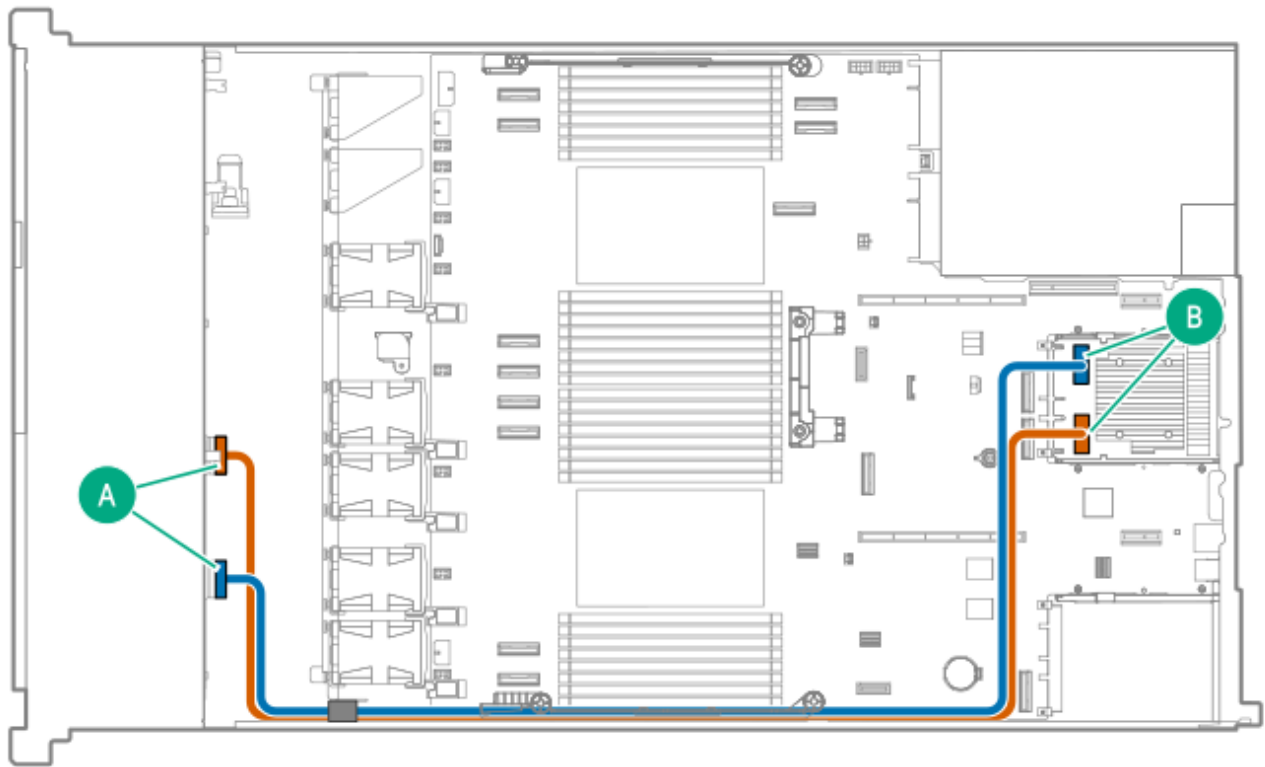

Cable part number	Color	From	To
P55357-001	Orange	8 SFF drive backplane	Slot 15 OCP B type-o controller Port 1i
P48961-001	Blue	2 SFF drive backplane	Slot 15 OCP B type-o controller Port 2i

8 SFF x1 NVMe + 2 SFF x4 NVMe controller cabling: type-p controller in Slot 1

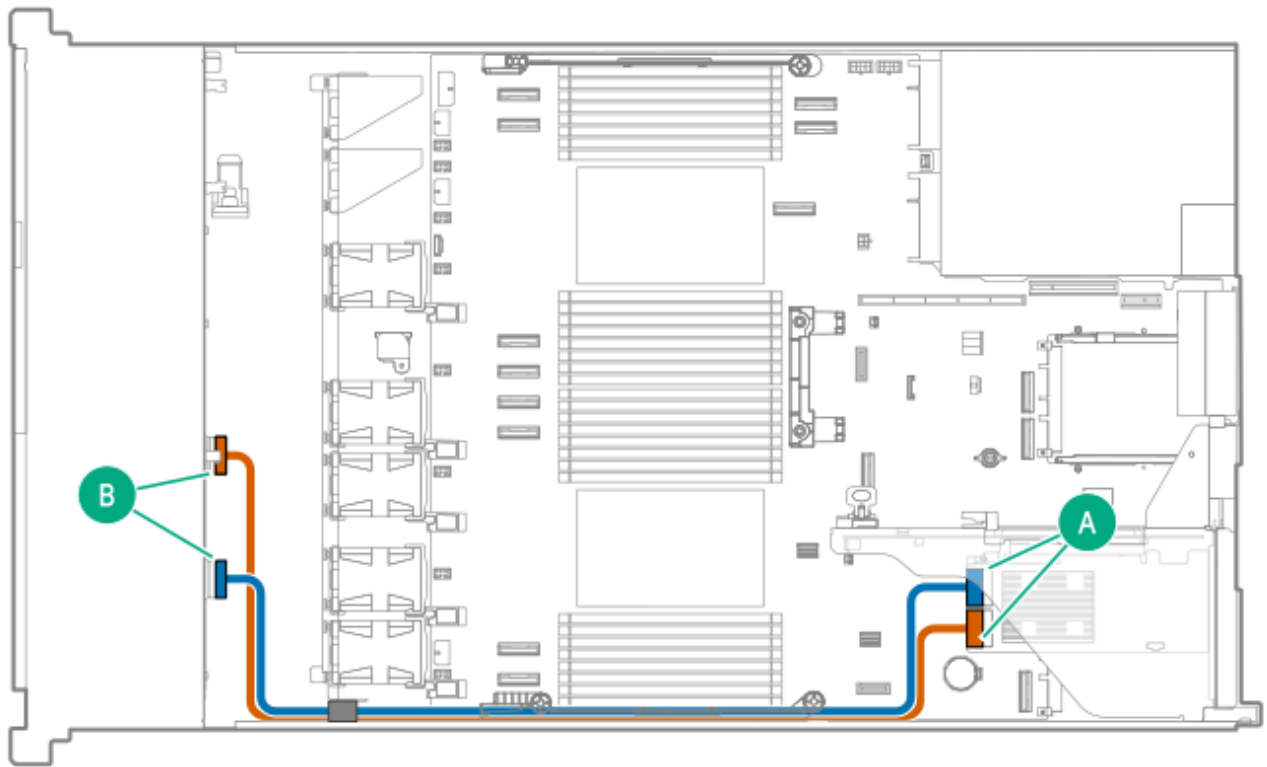

Cable part number	Color	From	To
P45610-001	Orange	8 SFF drive backplane	Slot 1 type-p controller Port 1i
P45611-001	Blue	2 SFF drive backplane	Slot 1 type-p controller Port 2i

8 SFF x1 NVMe to type-o controller in Slot 14 OCP A + 2 SFF x4 direct attach

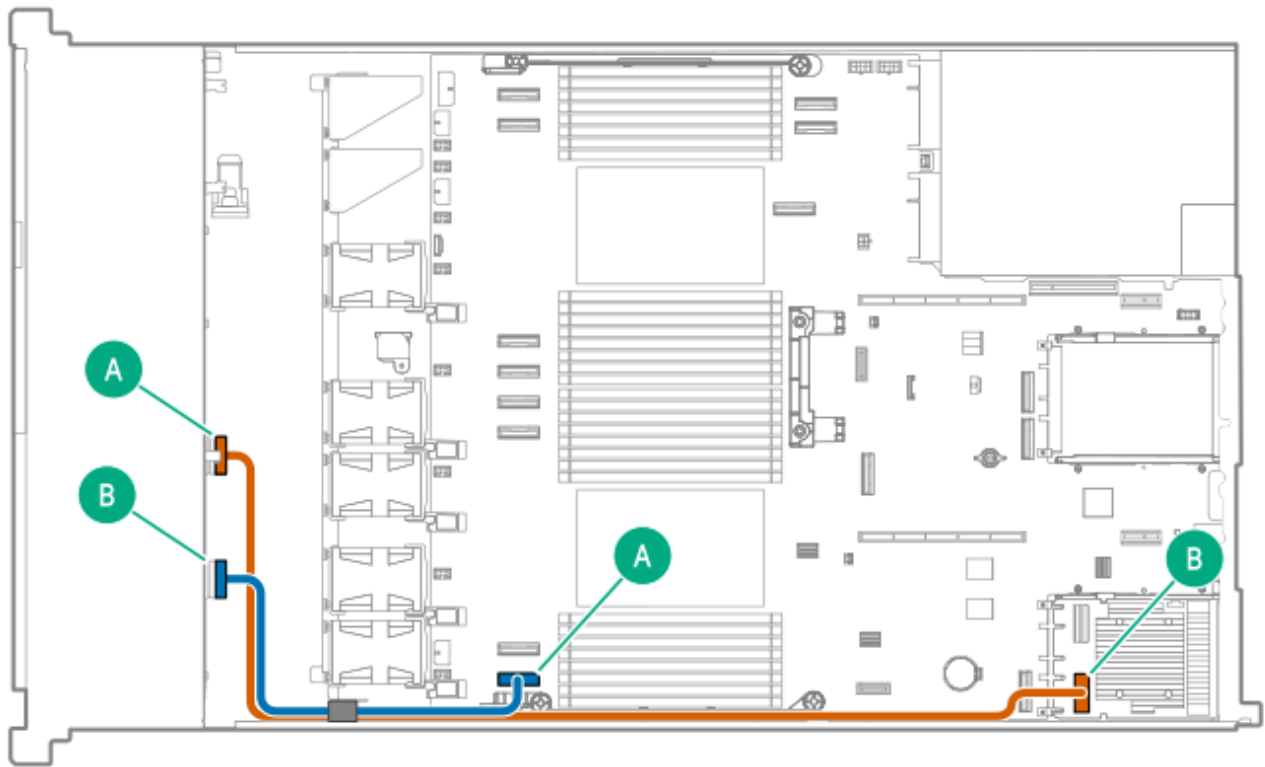

Cable part number	Color	From	To
P48960-001	Orange	8 SFF drive backplane	Slot 14 OCP A type-o controller Port 1i
P75946-001	Blue	2 SFF drive backplane	MCI0 port 1

8 SFF x1 NVMe to type-o controller + 2 SFF x4 NVMe to type-p controller

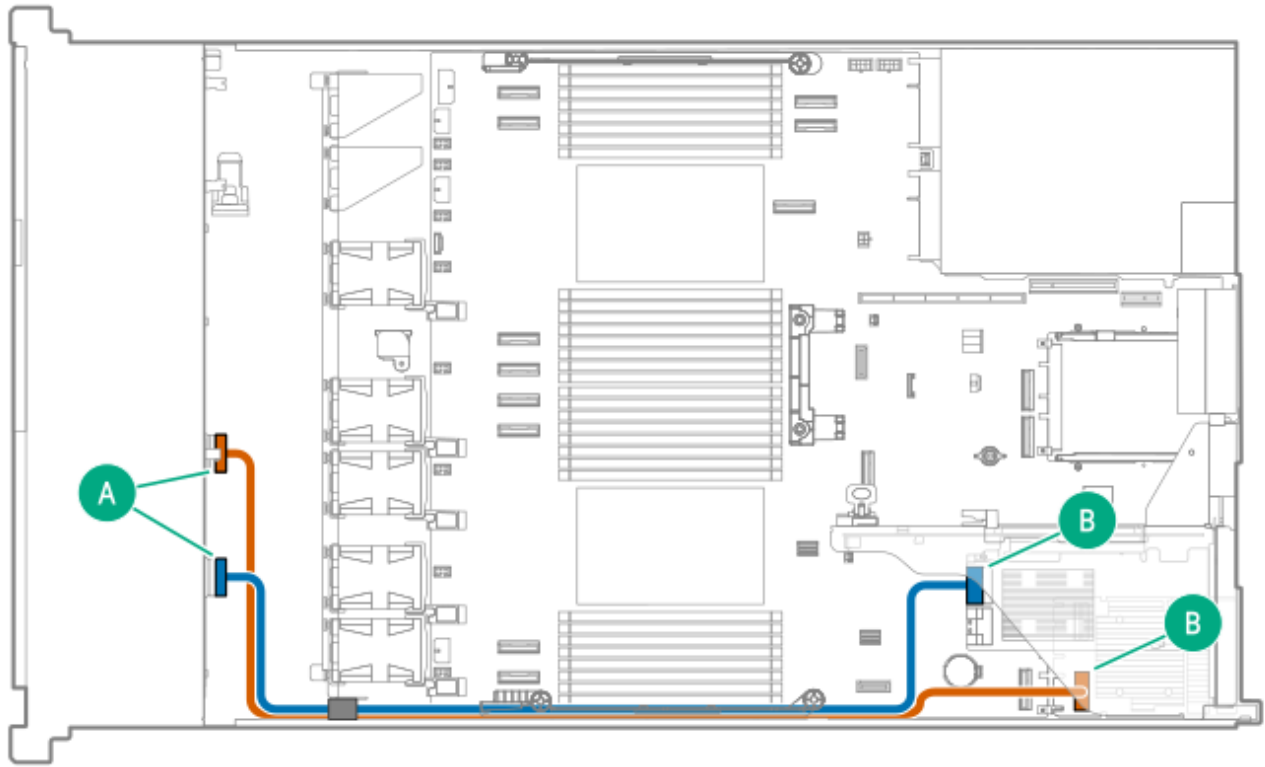

Cable part number	Color	From	To
P48960-001	Orange	8 SFF drive backplane	Slot 14 OCP A type-o controller Port 1i
P45611-001	Blue	2 SFF drive backplane	Slot 1 type-p controller Port 2i

8 SFF x1 NVMe to Slot 1 type-p controller + 2 SFF x4 NVMe to type-o controller in Slot 14 OCP A

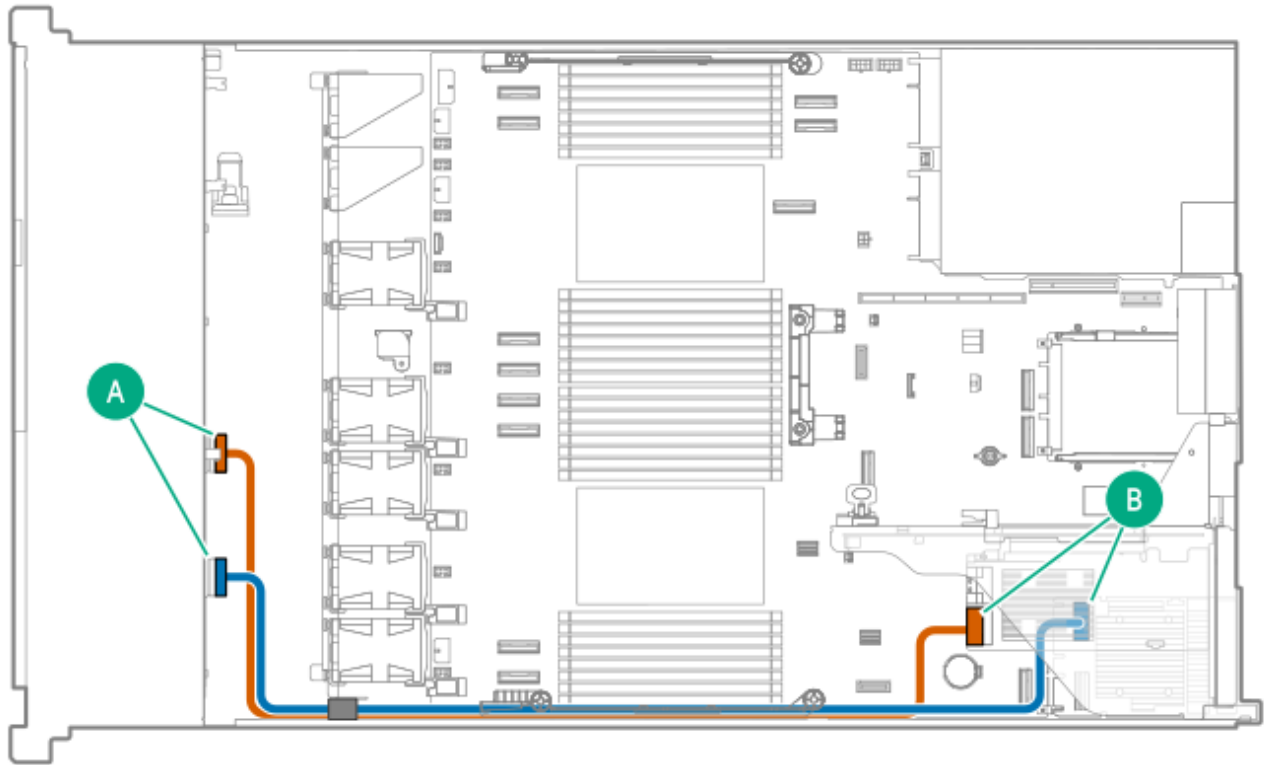

Cable part number	Color	From	To
P45610-001	Orange	8 SFF drive backplane	Slot 1 type-p controller Port 1i
P48962-001	Blue	2 SFF drive backplane	Slot 14 OCP A type-o controller Port 2i

8 SFF x1 NVMe to Slot 1 type-p controller + 2 SFF direct attach

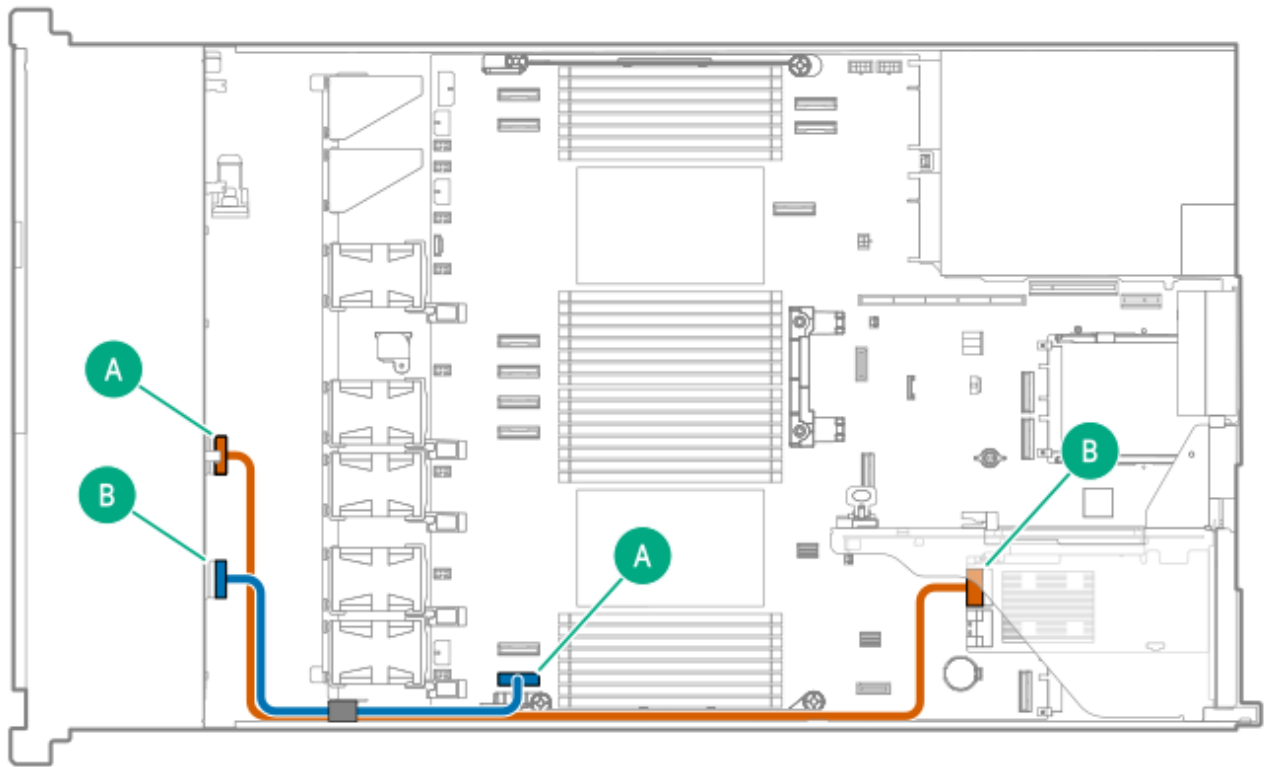

Cable part number	Color	From	To
P45610-001	Orange	8 SFF drive backplane	Slot 1 type-p controller Port 1i
P75946-001	Blue	2 SFF drive backplane	MCI0 port 1

8 SFF x1 NVMe to type-o controller in Slot 15 OCP B + 2 SFF x4 NVMe to type-p controller in Slot 2

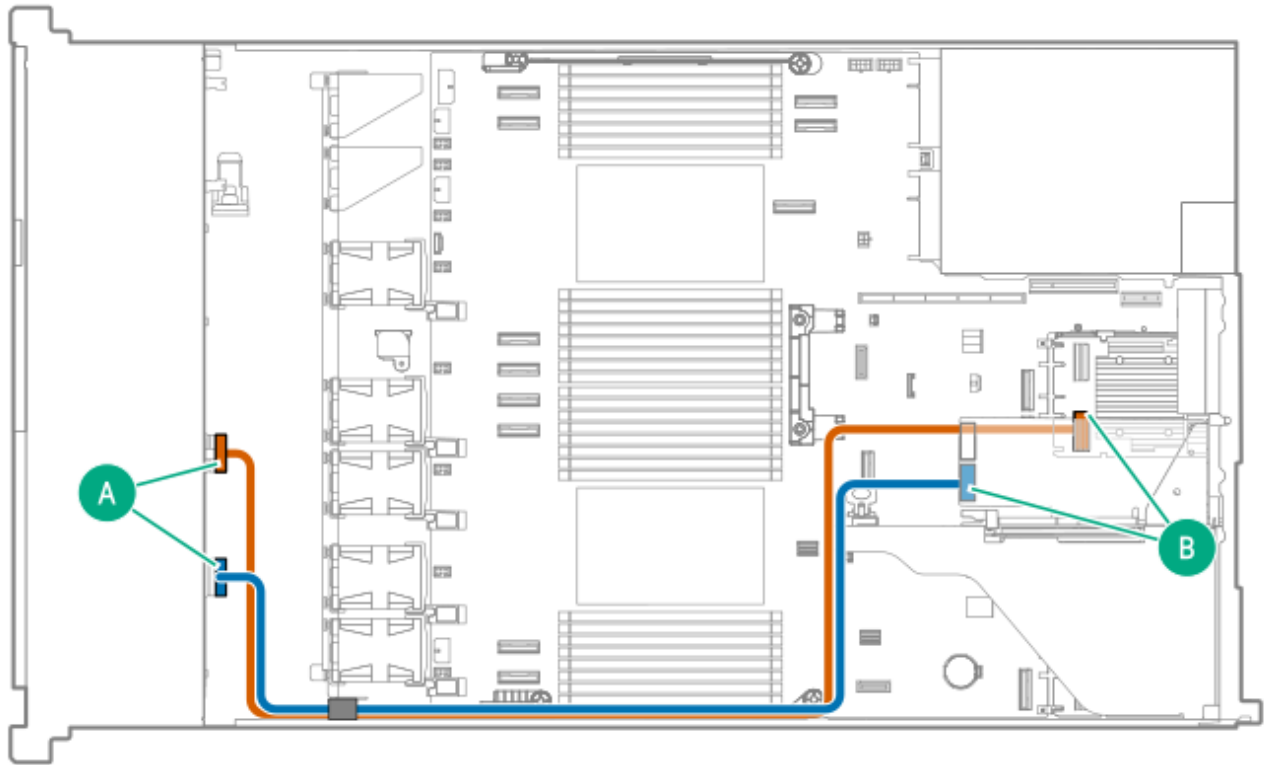

Cable part number	Color	From	To
P55357-001	Orange	8 SFF drive backplane	Slot 15 OCP B type-o controller Port 1i
P45611-001	Blue	2 SFF drive backplane	Slot 2 type-p controller Port 2i

8 SFF x1 NVMe to type-o controller in Slot 15 OCP B + 2 SFF x4 NVMe direct attach

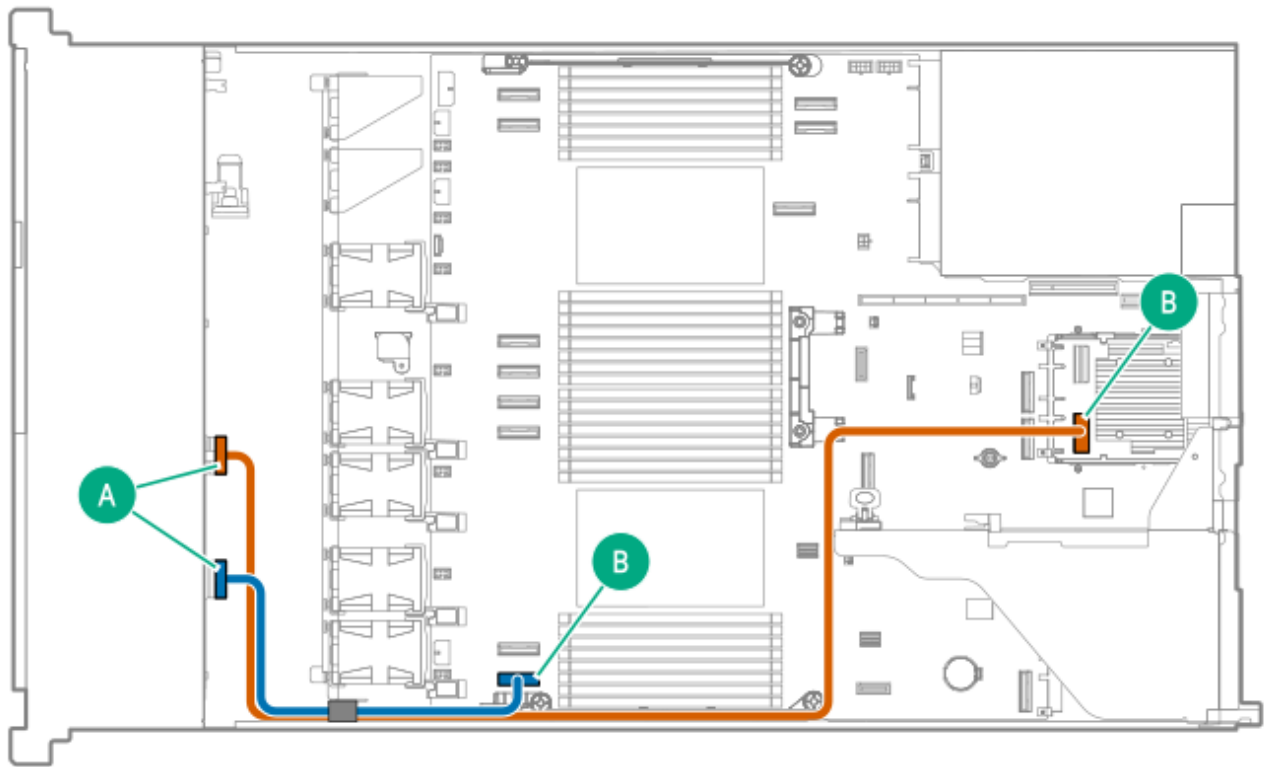

Cable part number	Color	From	To
P55357-001	Orange	8 SFF drive backplane	Slot 15 OCP B type-o controller Port 1i
P75946-001	Blue	2 SFF drive backplane	MCI0 port 1

8 SFF x1 NVMe to type-o controller in Slot 15 OCP B + 2 SFF x4 NVMe to type-o controller in Slot 14 OCP A

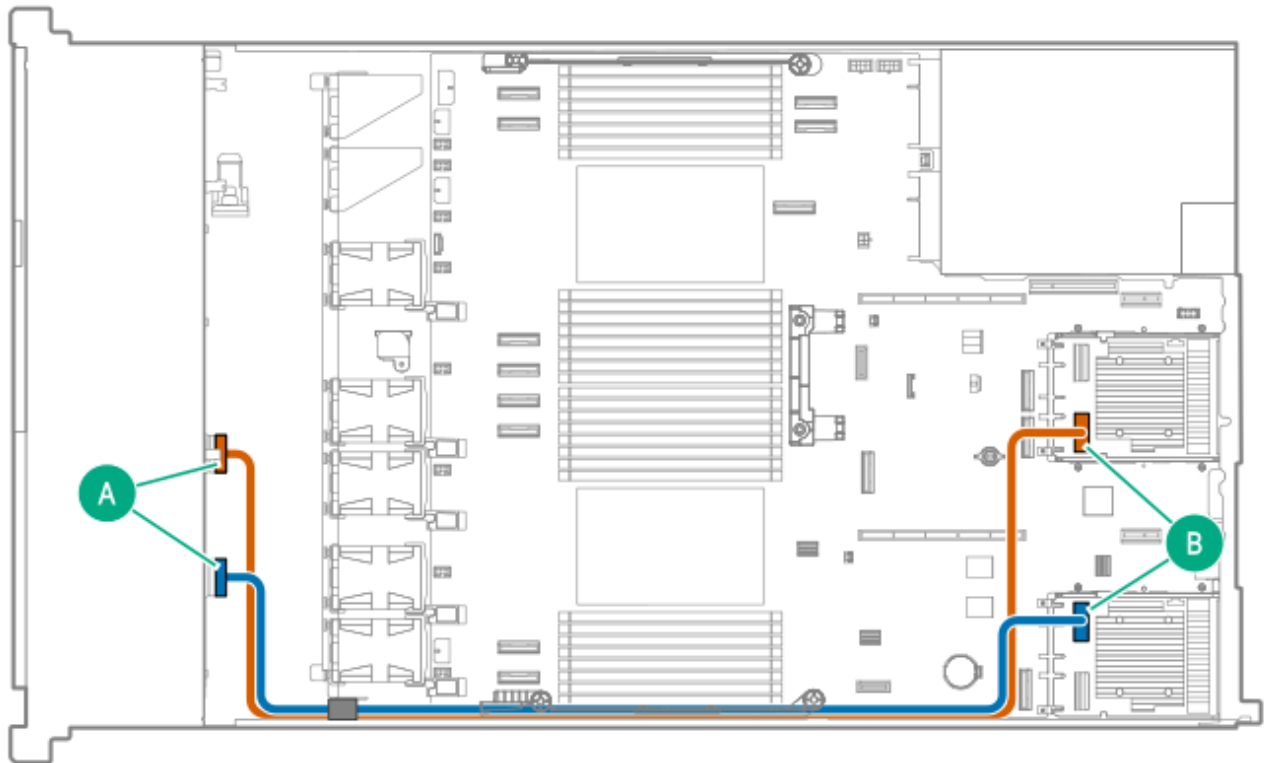

Cable part number	Color	From	To
P55357-001	Orange	8 SFF drive backplane	Slot 15 OCP B type-o controller Port 1i
P48962-001	Blue	2 SFF drive backplane	Slot 14 OCP A type-o controller Port 2i ¹

¹ When the MR408i-o is installed in OCP A, the cable is routed to Port 1i of the controller.

8 SFF x1 NVMe + 2 SFF x4 NVMe to type-p controller in Slot 2

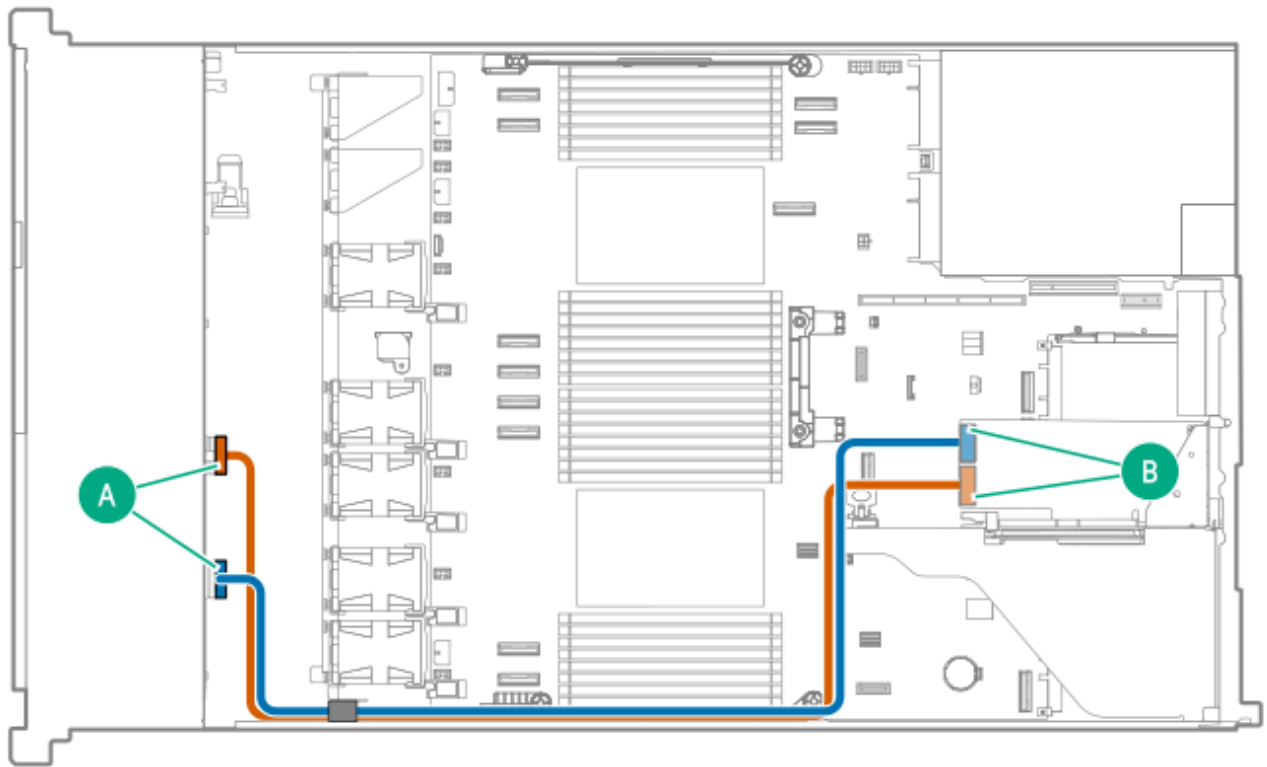

Cable part number	Color	From	To
P45610-001	Orange	8 SFF drive backplane	Slot 2 type-p controller Port 2i
P45611-001	Blue	2 SFF drive backplane	Slot 2 type-p controller Port 1i

8 SFF x1 NVMe to type-o controller in Slot 14 OCP A + 2 SFF x4 NVMe to type-o controller in Slot 15 OCP B

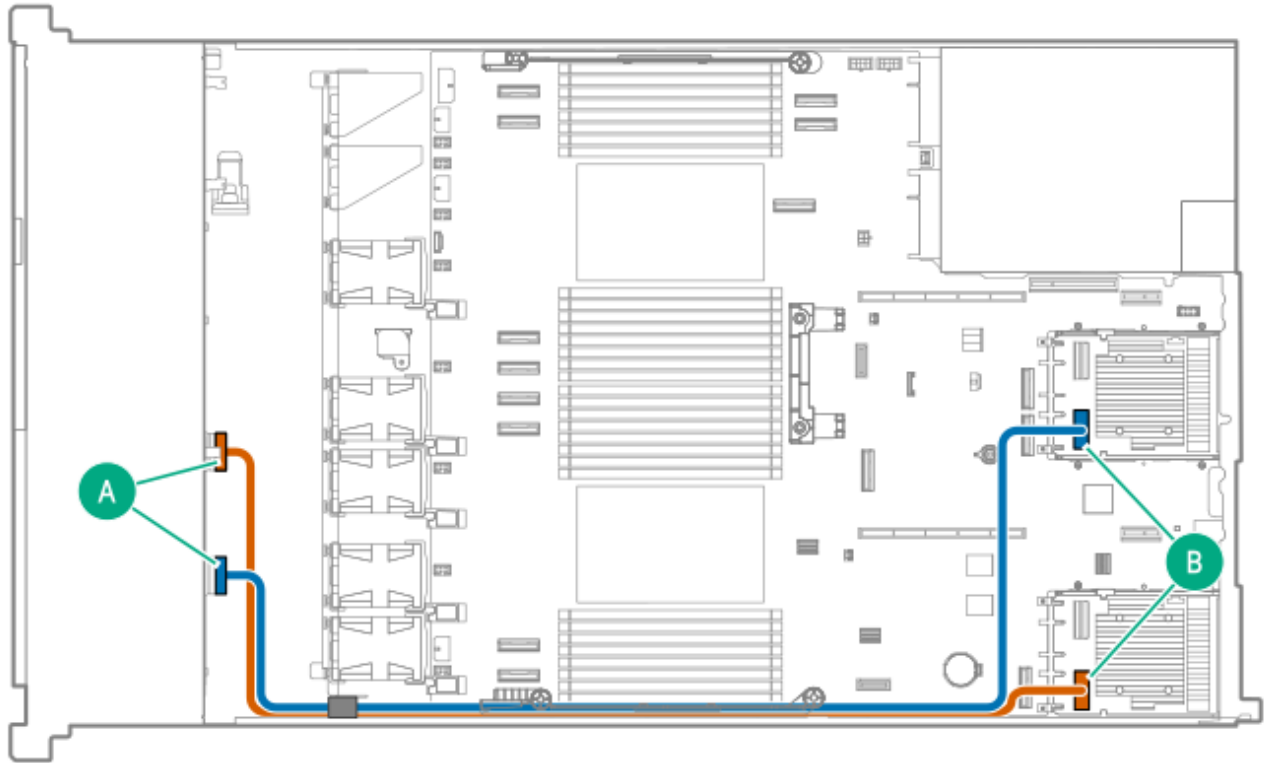

Cable part number	Color	From	To
P48960-001	Orange	8 SFF drive backplane	Slot 14 OCP A type-o controller Port 1i
P48961-001	Blue	2 SFF drive backplane	Slot 15 OCP B type-o controller Port 1i

8 SFF x1 NVMe to type-o controller in Slot 14 OCP A + 2 SFF x4 NVMe to Slot 2 type-p controller

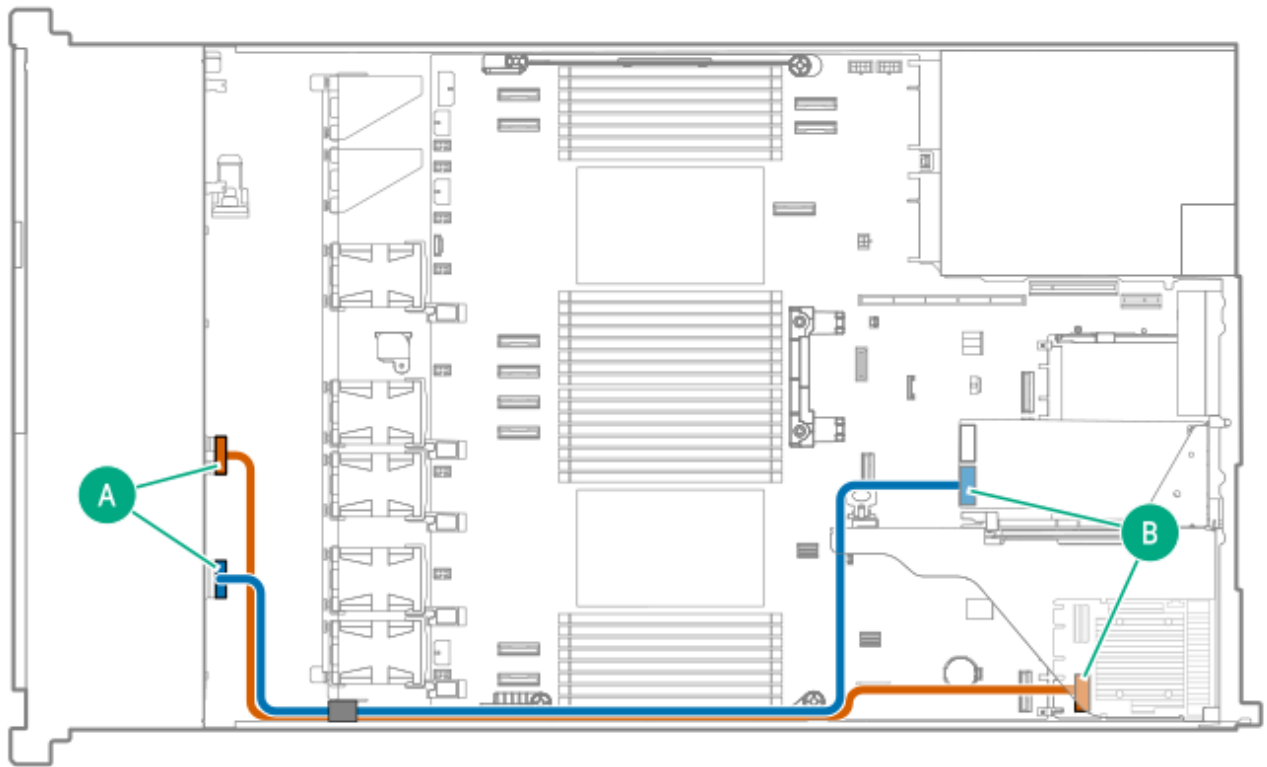

Cable part number	Color	From	To
P48960-001	Orange	8 SFF drive backplane	Slot 14 OCP A type-o controller Port 1i
P45611-001	Blue	2 SFF drive backplane	Slot 2 type-p controller Port 2i

8 SFF x1 NVMe + 2 SFF x4 NVMe to type-p controller in Slot 1

MR932i-p:



Cable part number	Color	From	To
P79151-001	Orange	8 SFF drive backplane	Slot 1 type-p controller Port 3i

Cable part number	Color	From	To
P76443-001	Blue	2 SFF drive backplane	Slot 1 type-p controller Port 2i

8 SFF x1 NVMe to type-o controller + 2 SFF x4 NVMe to type-p controller in Slot 1

MR932i-p:

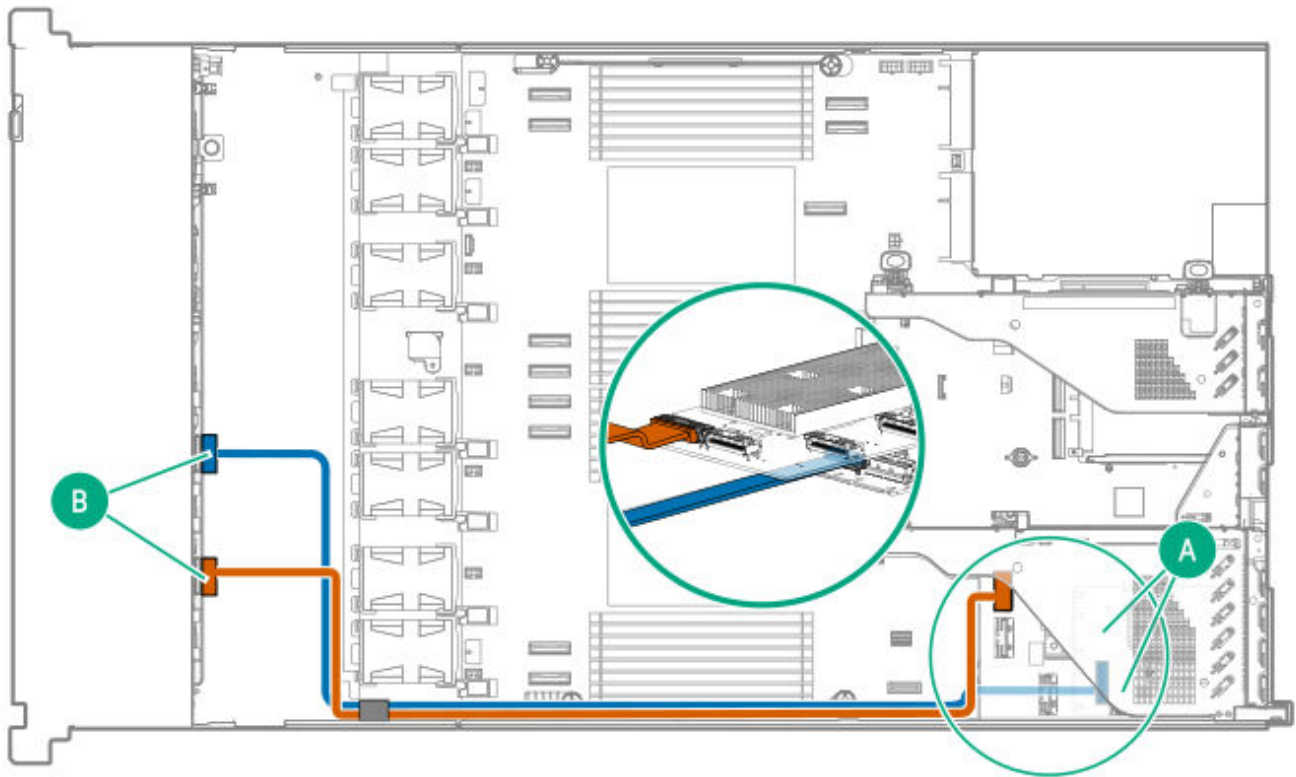

Cable part number	Color	From	To
P76443-001	Orange	2 SFF drive backplane	Slot 1 type-p controller Port 2i
P48960-001	Blue	8 SFF drive backplane	Slot 14 OCP A type-o controller Port 1i

8 SFF x1 NVMe to type-p controller in Slot 1 + 2 SFF x4 NVMe to type-o controller

MR932i-p:

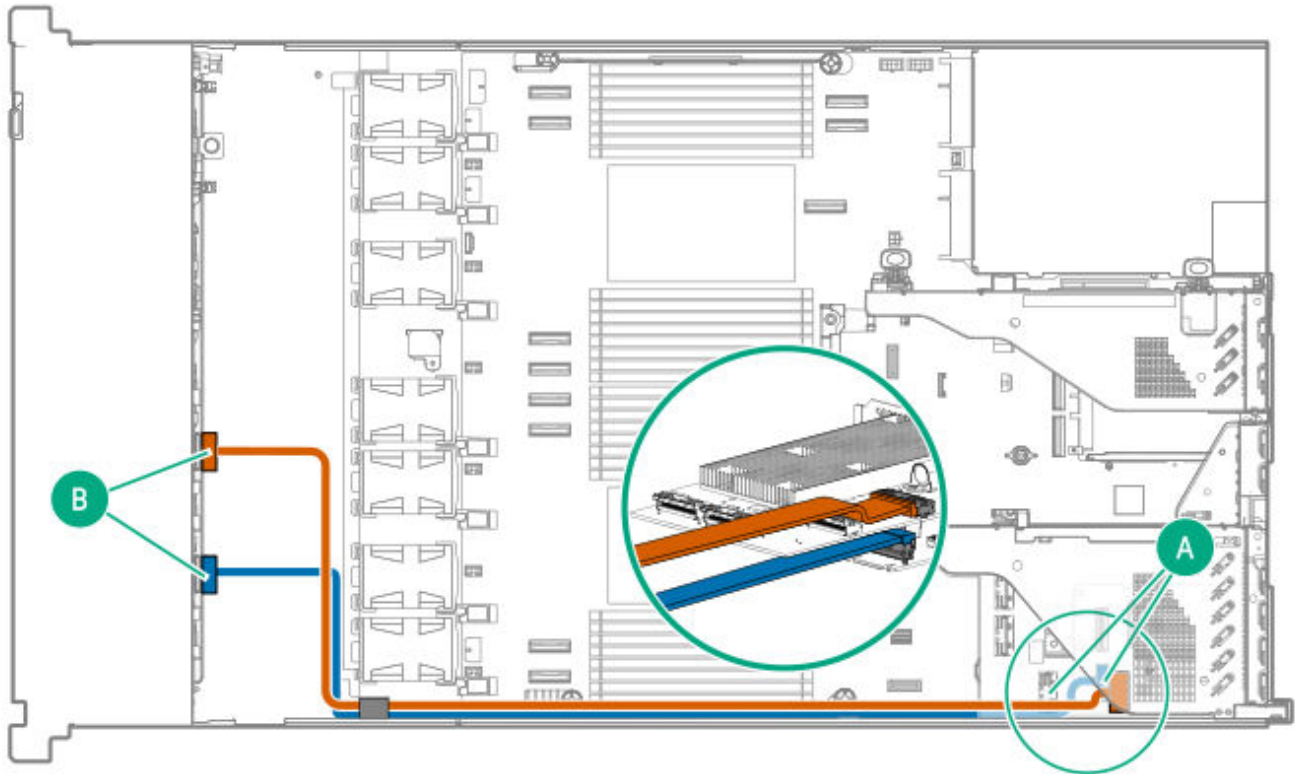

Cable part number	Color	From	To
P79151-001	Orange	8 SFF drive backplane	Slot 1 type-p controller Port 3i
P48962-001	Blue	2 SFF drive backplane	Slot 14 OCP A type-o controller Port 1i

8 SFF x1 NVMe to type-p controller in Slot 1 + 2 SFF x4 NVMe direct attach

MR932i-p:

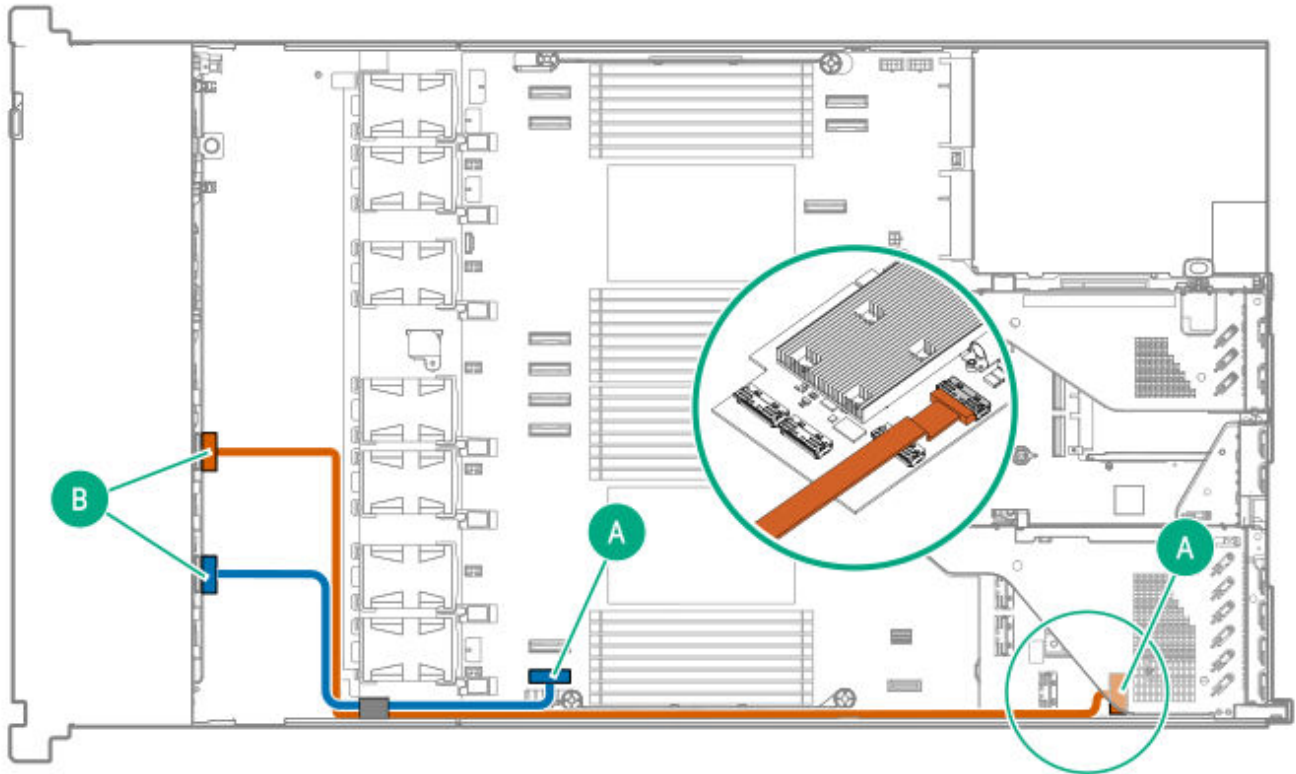

Cable part number	Color	From	To
P79151-001	Orange	8 SFF drive backplane	Slot 1 type-p controller Port 3i
P75946-001	Blue	2 SFF drive backplane	MCIO port 1

4 E3.S stacked drive backplane cabling

The 4 E3.S stacked drive backplane is supported in the 10 SFF / 20 E3.S server or servers using the mixed drive type configuration.

Subtopics

[Drive Box 1 cabling](#)

[Drive Box 2 cabling](#)

[Drive Box 3 cabling](#)

[Drive Box 4 cabling](#)

[Drive Box 5 cabling](#)

- Drive box cabling for Boxes 1-2**
- Drive box cabling for boxes 1 and 4**
- Drive box cabling for boxes 1 and 5**
- Drive box cabling for boxes 4-5**

Drive Box 1 cabling

4 EDSFF Box 1: direct attach (unbalanced, 1 CPU)

This cable routing is compatible with a single-processor configuration.

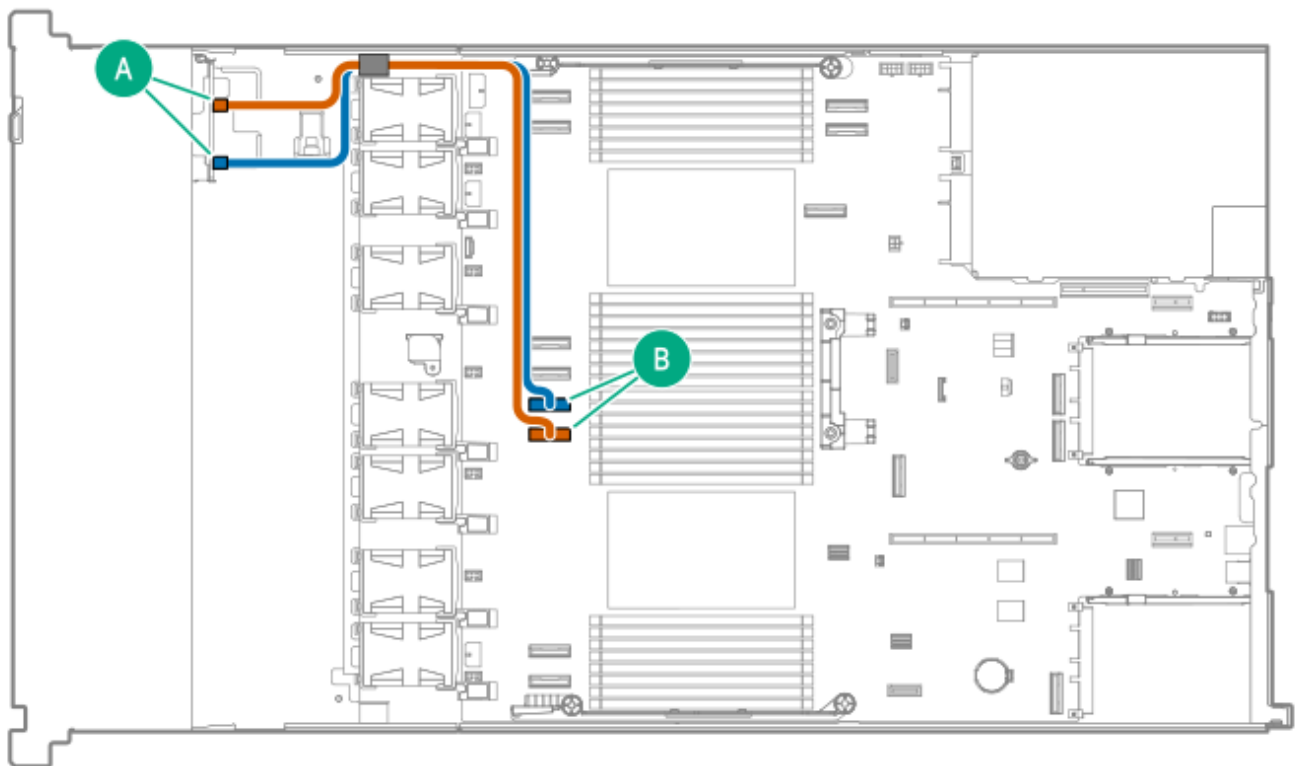

Cable part number	Color	From	To
P75568-001	Orange	Drive backplane port 1	MCIO port 3
P75568-001	Blue	Drive backplane port 2	MCIO port 4

4 EDSFF Box 1: direct attach (unbalanced)

This cable routing is compatible with a dual-processor configuration.

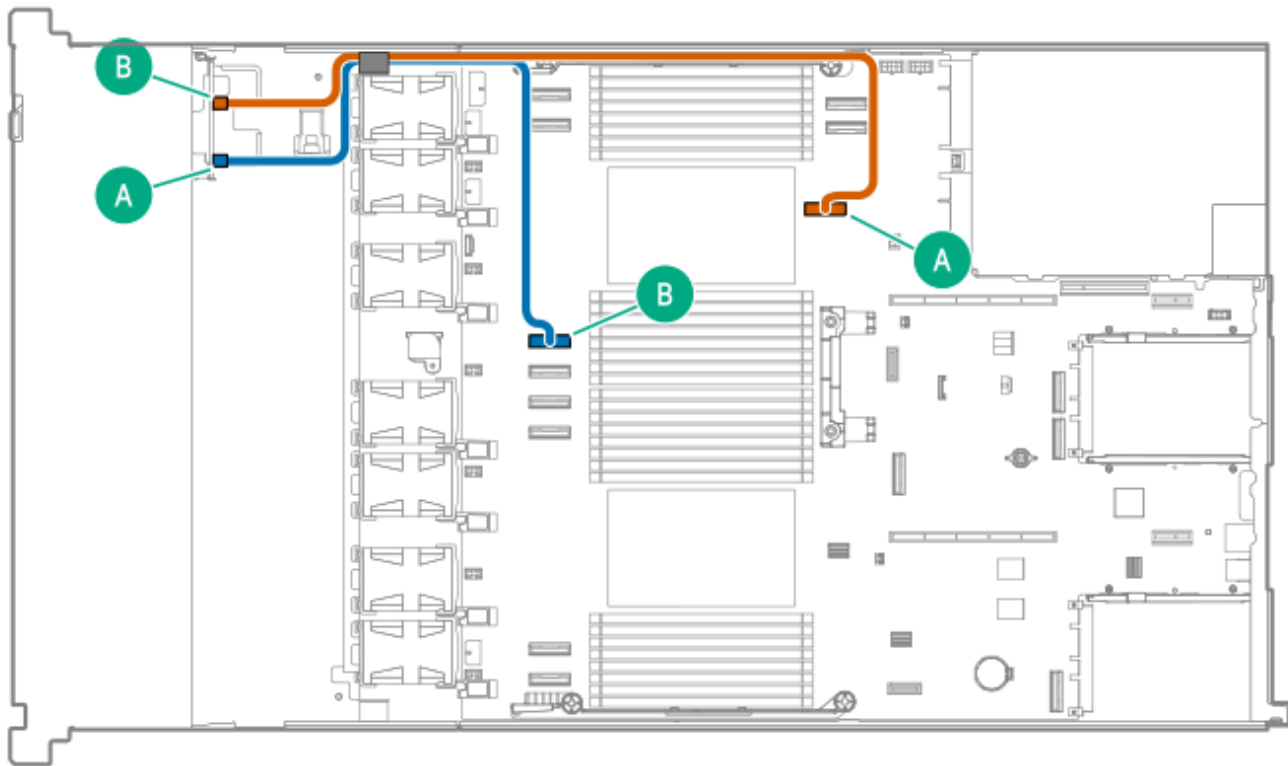

Cable part number	Color	From	To
P75568-001	Orange	Drive backplane port 1	MCIO port 11
P75278-001	Blue	Drive backplane port 2	MCIO port 6

4 EDSFF Box 1: type-p controller in the secondary riser

This configuration supports the closed-loop liquid cooling kit.

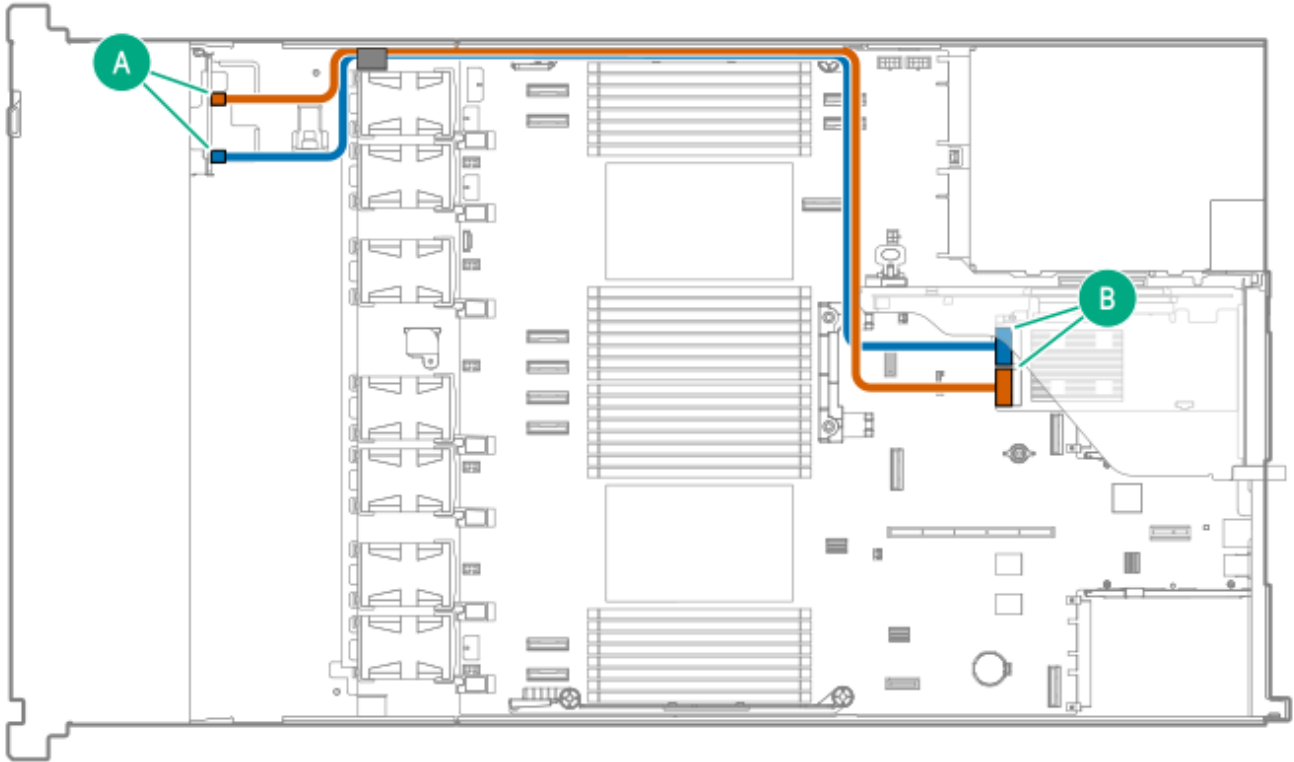

Cable part number	Color	From	To
P74805-001	Orange	Drive backplane port 1	Slot 3 type-p controller Port 1i
P74805-001	Blue	Drive backplane port 2	Slot 3 type-p controller Port 2i

Drive Box 3 cabling

4 EDSFF Box 3 x4 NVMe: direct attach

This cable routing is compatible with a dual-processor configuration.

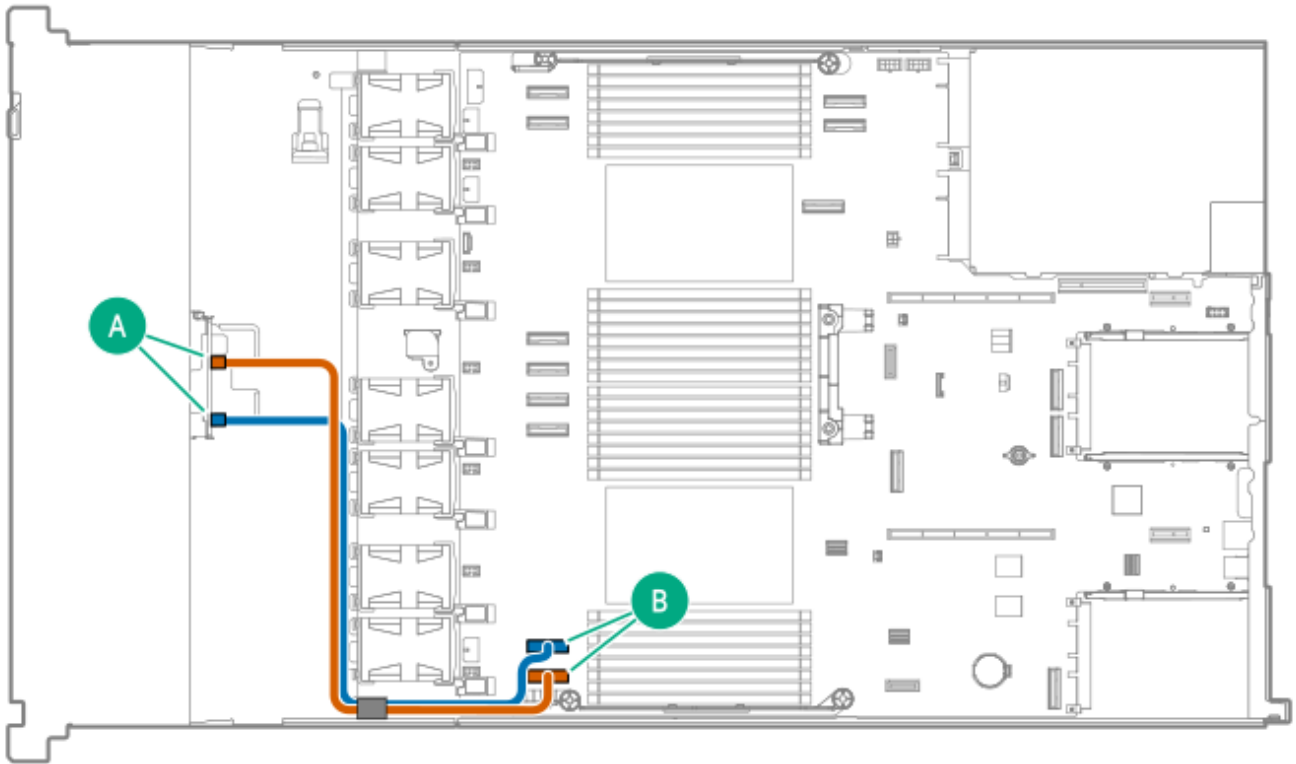

Cable part number	Color	From	To
P75278-001	Orange	Drive backplane port 1	MCIO port 1
P75278-001	Blue	Drive backplane port 2	MCIO port 2

Drive Box 4 cabling

4 EDSFF Box 4 x4 NVMe: direct attach

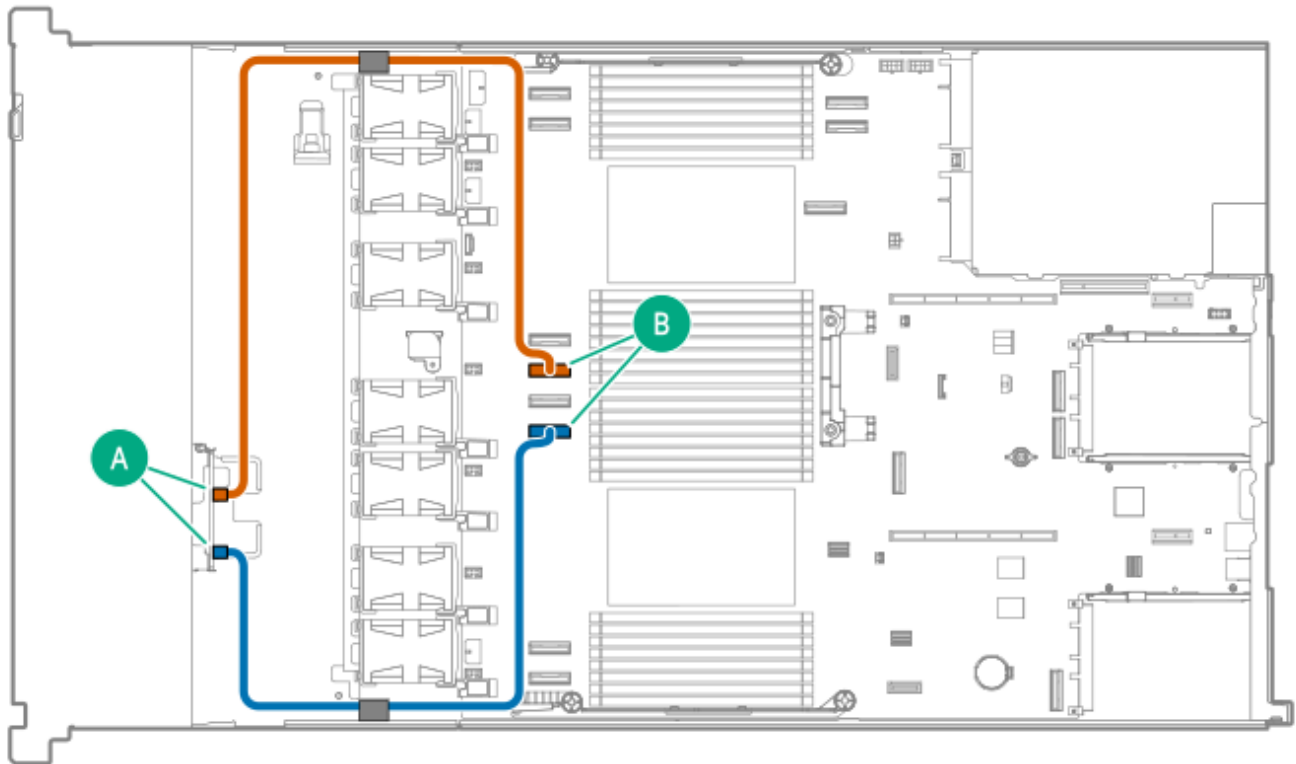

Cable part number	Color	From	To
P74806-001	Orange	Drive backplane port 1	MCIo port 5
P75278-001	Blue	Drive backplane port 2	MCIo port 3

4 EDSFF Box 4 x4 NVMe: type-p controller in Slot 1

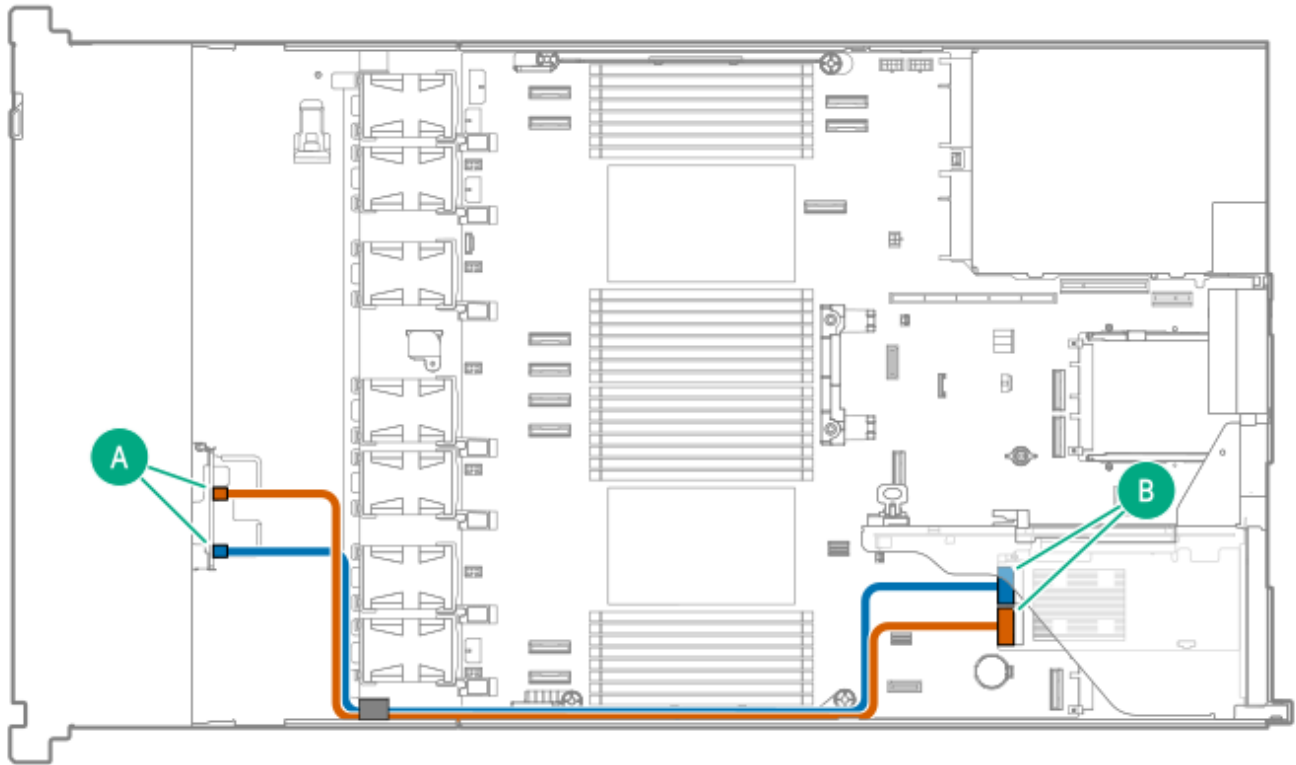

Cable part number	Color	From	To
P75590-001	Orange	Drive backplane port 1	Primary type-p controller Port 1i
	Blue	Drive backplane port 2	Primary type-p controller Port 2i

4 EDSFF Box 4 x4 NVMe: type-p controller in Slot 2

This configuration supports the closed-loop liquid cooling kit.

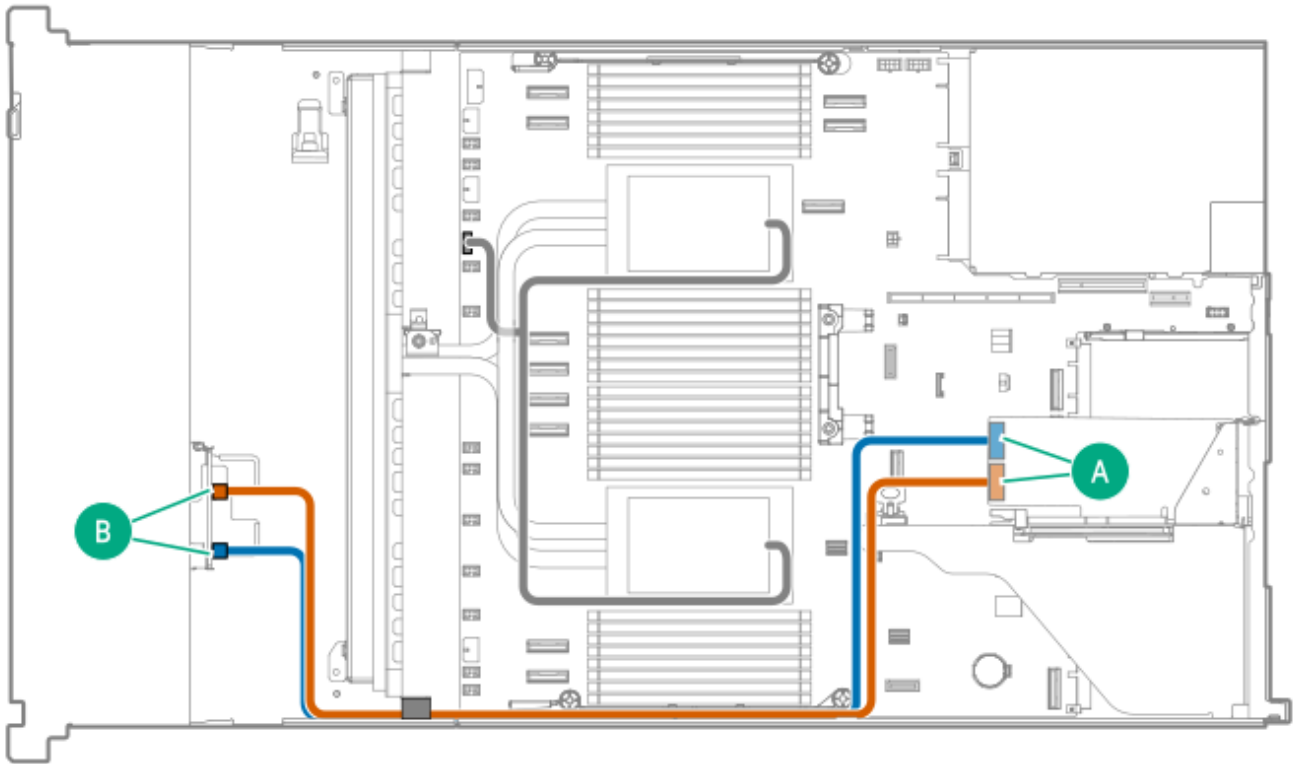

Cable part number	Color	From	To
P75590-001	Orange	Drive backplane port 1	Primary type-p controller Port 2i
	Blue	Drive backplane port 2	Primary type-p controller Port 1i

Drive Box 5 cabling

4 EDSFF Box 5 x4 NVMe: direct attach

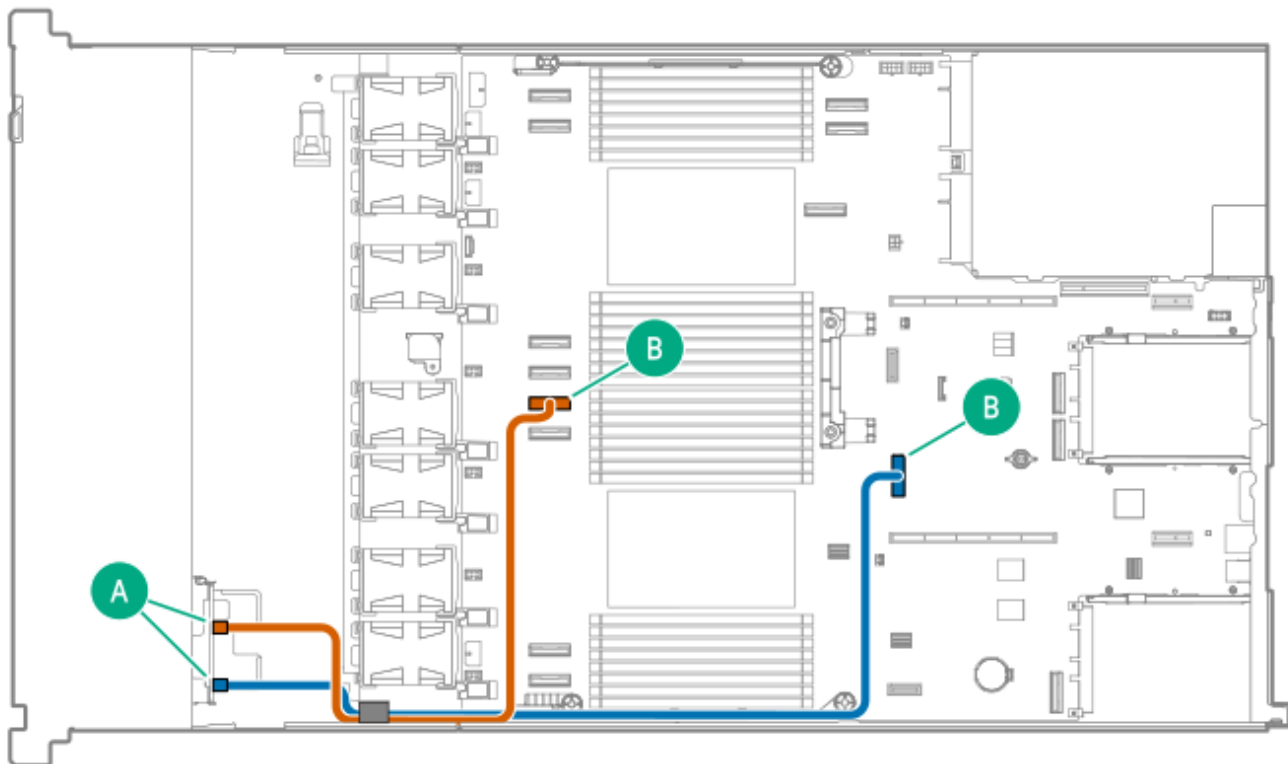

Cable part number	Color	From	To
P75278-001	Orange	Drive backplane port 1	MCIo port 4
P75567-001	Blue	Drive backplane port 2	MCIo port 12

4 EDSFF Box 5 x4 NVMe: type-p controller in Slot 1



Cable part number	Color	From	To
P76443-001	Orange	Drive backplane port 1	Slot 1 type-p controller Port 2i
P75574-001	Blue	Drive backplane port 2	Slot 1 type-p controller Port 1i

4 EDSFF Box 5 x4 NVMe: type-p controller in Slot 2

This configuration supports the closed-loop liquid cooling kit.

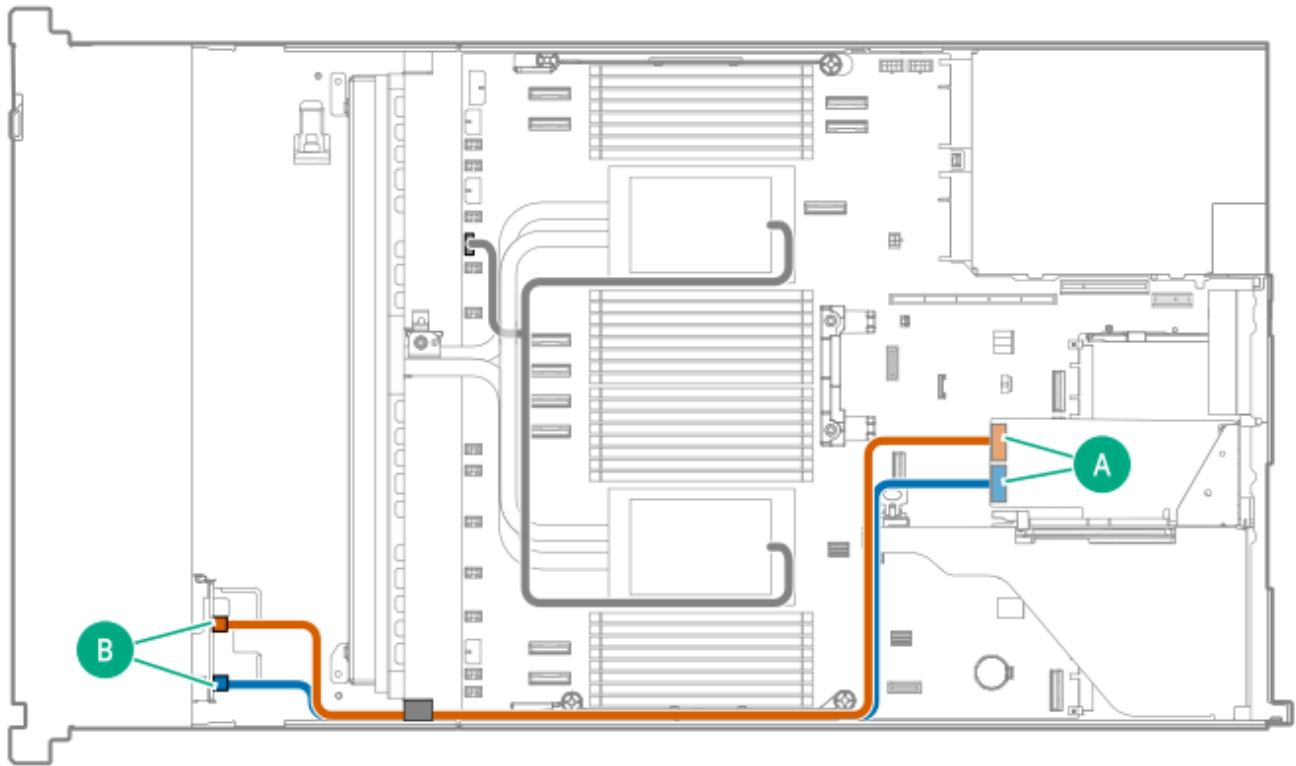

Cable part number	Color	From	To
P76443-001	Orange	Drive backplane port 1	Slot 2 type-p controller Port 1i
P75574-001	Blue	Drive backplane port 2	Slot 1 type-p controller Port 2i

4 EDSFF Box 5 x4 NVMe: type-o controller

This cable routing is compatible with a dual-processor configuration.

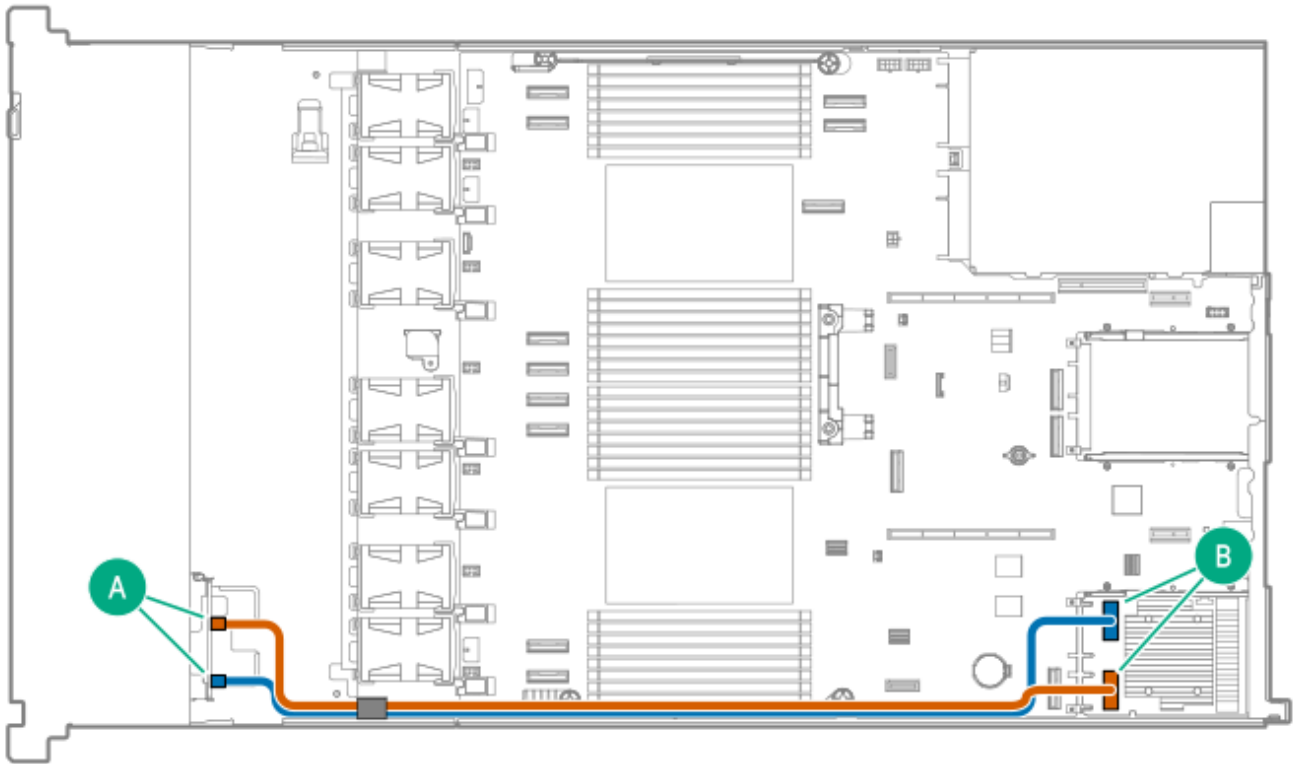

Cable part number	Color	From	To
P75589-001	Orange	Drive backplane port 1	Type-o controller Port 1i in Slot 14 OCP A
P75589-001	Blue	Drive backplane port 2	Type-o controller Port 2i in Slot 14 OCP A

Drive box cabling for Boxes 1-2

8 EDSFF Boxes 1-2: direct attach

This configuration supports the closed-loop liquid cooling kit.

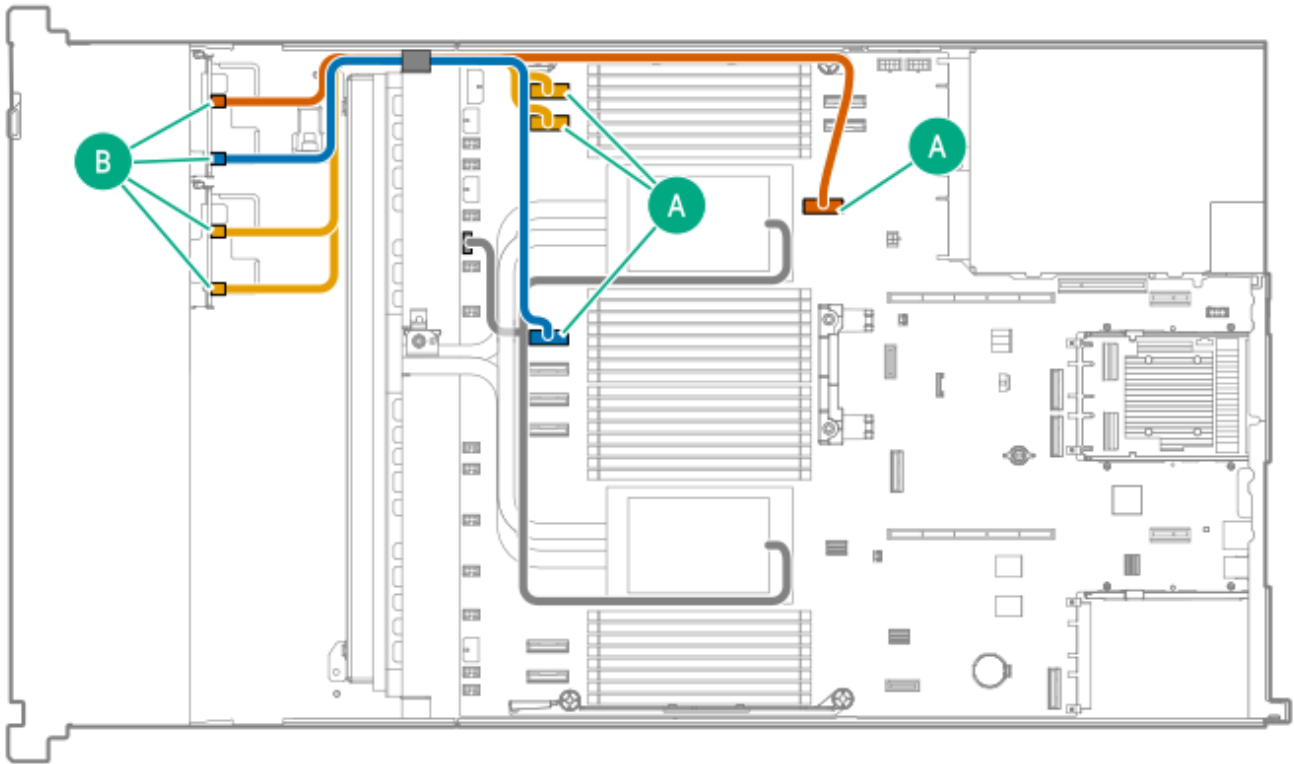

Cable part number	Color	From	To
P75568-001	Orange	Box 1: Drive backplane port 1	MCIO port 11
P75278-001	Blue	Box 1: Drive backplane port 2	MCIO port 6
P75317-001	Gold	Box 2: Drive backplane port 1	MCIO port 7
		Box 2: Drive backplane port 2	MCIO port 8

8 EDSFF Boxes 1–2 x4 NVMe to type-p controller in Slot 1 (1 CPU)

This cable routing is compatible with a single-processor configuration.

MR932i-p:

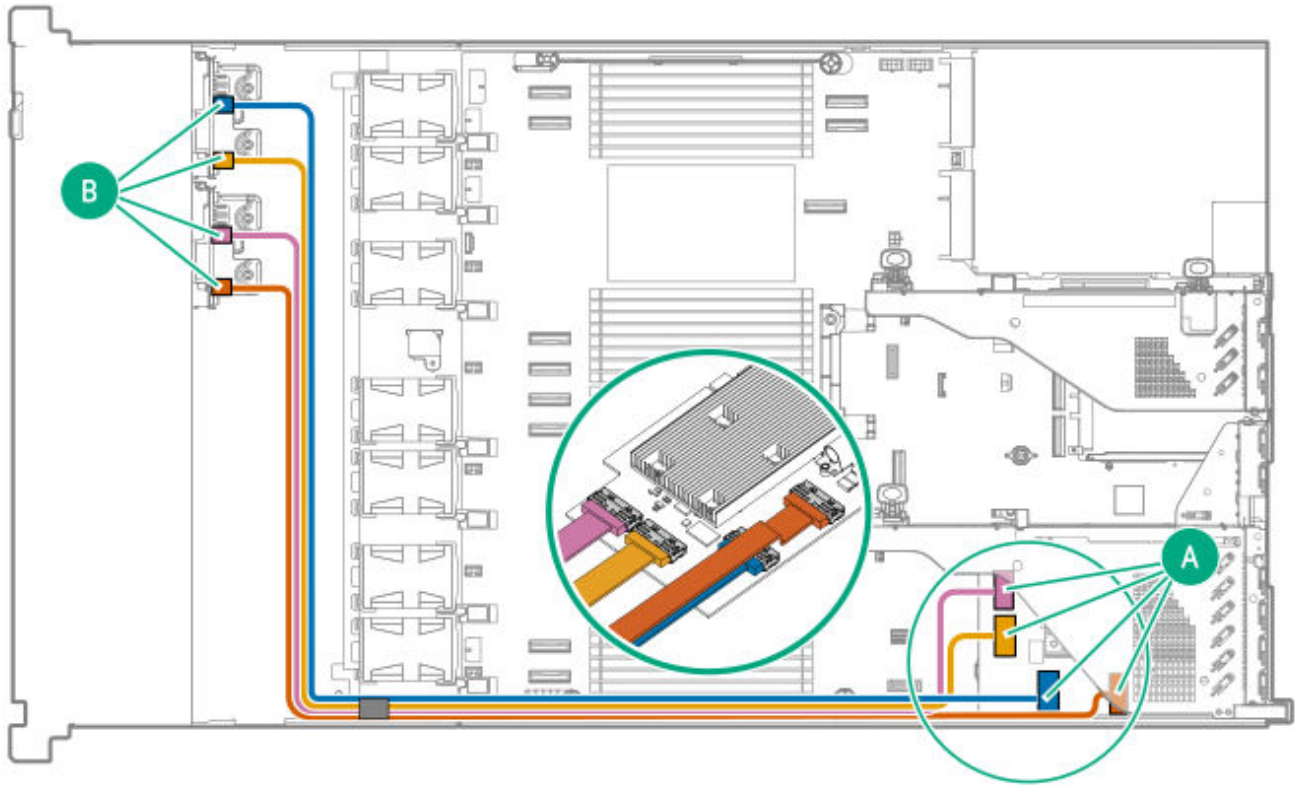

Cable part number	Color	From	To
P75318-001	Blue	Box 1: Drive backplane port 1	Slot 1 type-p controller Port 4i
	Gold	Box 1: Drive backplane port 2	Slot 1 type-p controller Port 1i
	Pink	Box 2: Drive backplane port 1	Slot 1 type-p controller Port 2i
	Orange	Box 2: Drive backplane port 2	Slot 1 type-p controller Port 3i

8 EDSFF x4 Boxes 1-2 NVMe to type-p controller in Slot 3

MR932i-p:

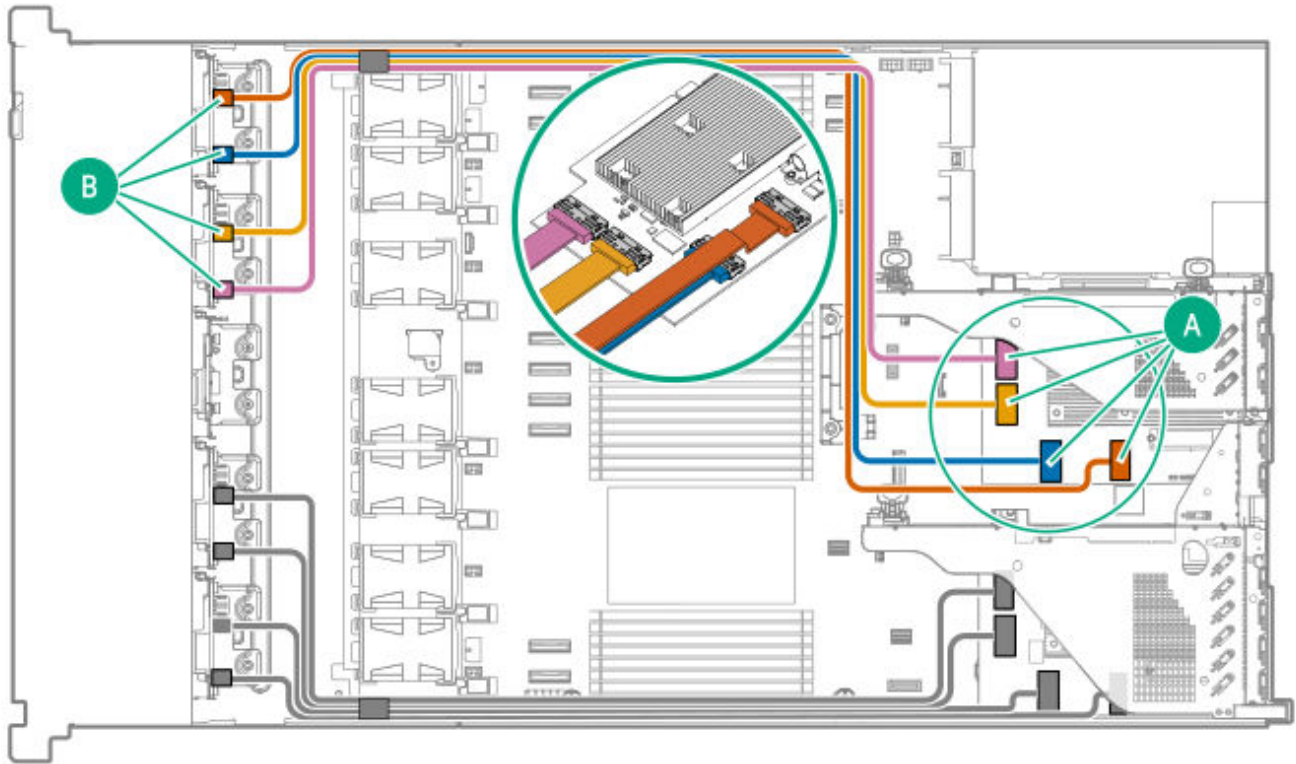

Cable part number	Color	From	To
P75318-001	Orange	Box 1: Drive backplane port 1	Slot 3 type-p controller Port 3i
	Blue	Box 1: Drive backplane port 2	Slot 3 type-p controller Port 4i
	Gold	Box 2: Drive backplane port 1	Slot 3 type-p controller Port 1i
	Pink	Box 2: Drive backplane port 2	Slot 3 type-p controller Port 2i

Drive box cabling for boxes 1 and 4

8 EDSFF Boxes 1 and 4 x4 NVMe to type-p controller in Slot 1 (1 CPU)

This cable routing is compatible with a single-processor configuration.

MR932i-p:

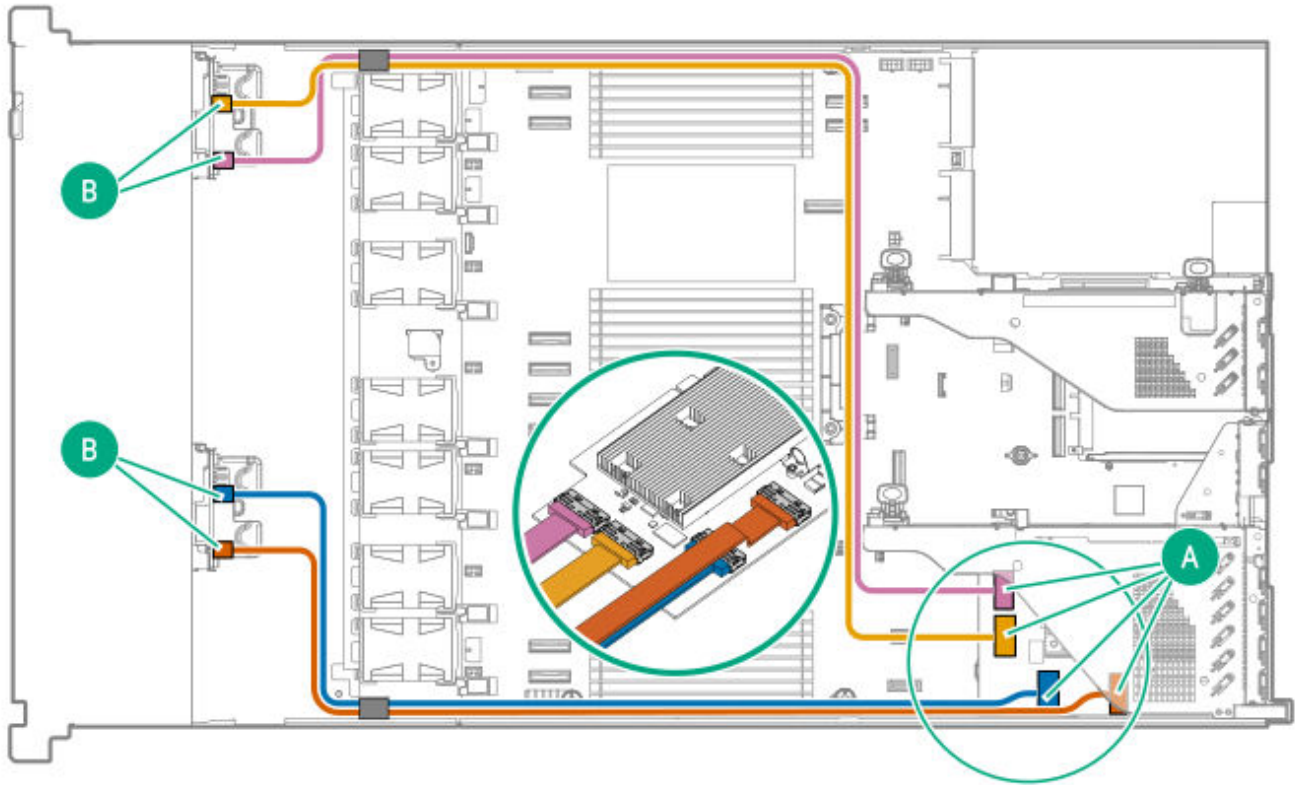

Cable part number	Color	From	To
P75318-001	Gold	Box 1: Drive backplane port 1	Slot 1 type-p controller Port 1i
	Pink	Box 1: Drive backplane port 2	Slot 1 type-p controller Port 2i
P75570-001	Blue	Box 4: Drive backplane port 1	Slot 1 type-p controller Port 4i
	Orange	Box 4: Drive backplane port 2	Slot 1 type-p controller Port 3i

Drive box cabling for boxes 1 and 5

8 EDSFF Boxes 1 and 5 x4 NVMe to type-p controller in Slot 1 (1 CPU)

This cable routing is compatible with a single-processor configuration.

MR932i-p:

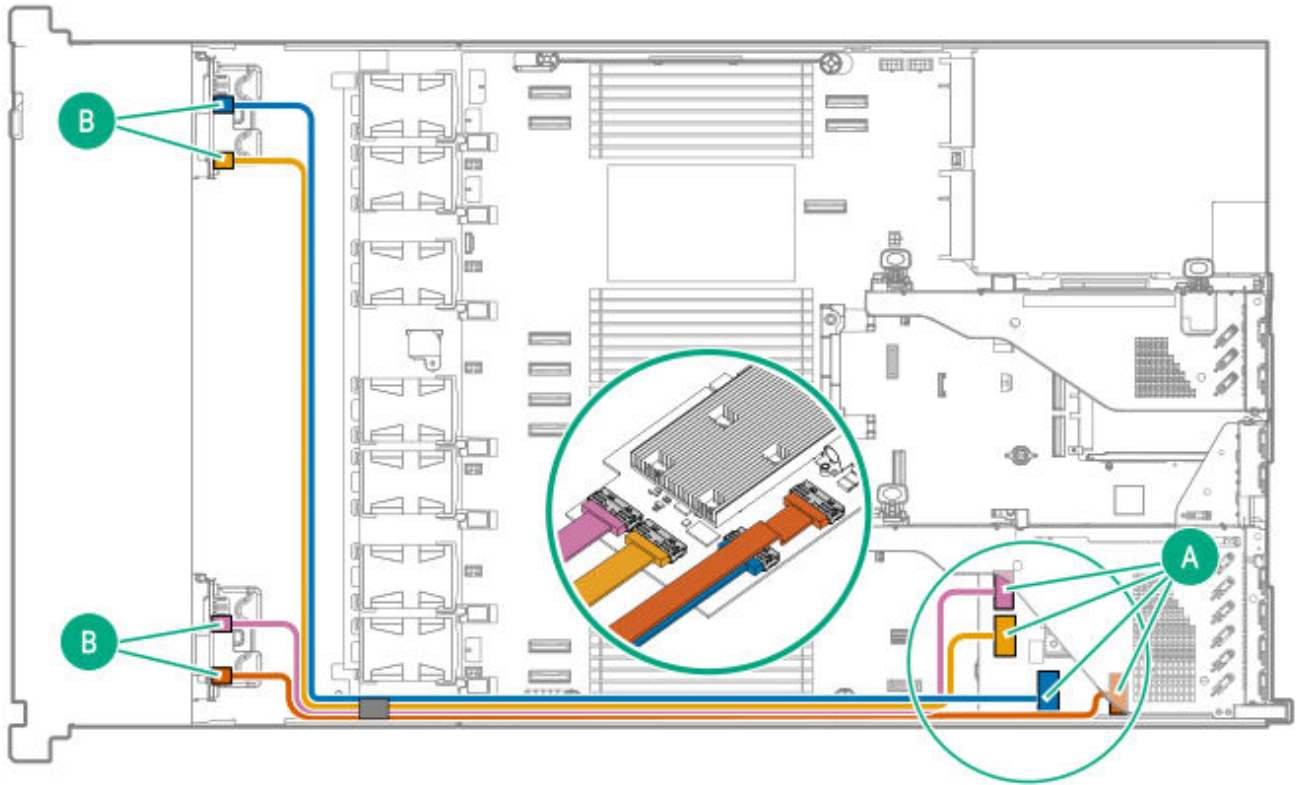

Cable part number	Color	From	To
P75318-001	Blue	Box 1: Drive backplane port 1	Slot 1 type-p controller Port 4i
	Gold	Box 1: Drive backplane port 2	Slot 1 type-p controller Port 1i
P75570-001	Pink	Box 5: Drive backplane port 1	Slot 1 type-p controller Port 2i
P75569-001	Orange	Box 5: Drive backplane port 2	Slot 1 type-p controller Port 3i

Drive box cabling for boxes 4-5

8 EDSFF Boxes 4-5 x4 NVMe to type-p controller in Slot 1

MR932i-p:

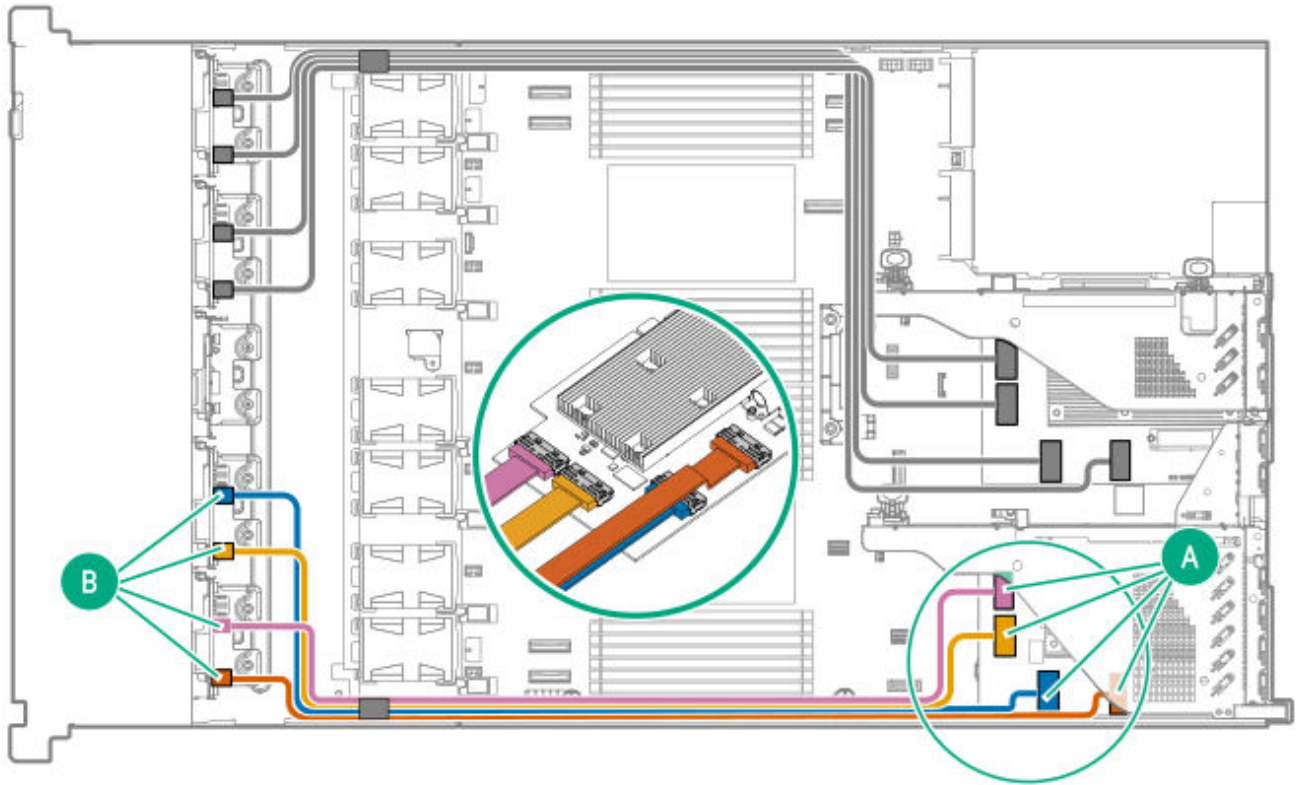

Cable part number	Color	From	To
P75570-001	Blue	Box 4: Drive backplane port 1	Slot 1 type-p controller Port 4i
	Gold	Box 4: Drive backplane port 2	Slot 1 type-p controller Port 1i
	Pink	Box 5: Drive backplane port 1	Slot 1 type-p controller Port 2i
P75569-001	Orange	Box 5: Drive backplane port 2	Slot 1 type-p controller Port 3i

2 SFF stacked drive backplane cabling

The 2 SFF stacked drive backplane is supported in the 10 SFF / 20 E3.S server or servers using the mixed drive type configuration.

Subtopics

Drive Box 1 cabling

Drive Box 2 cabling

Drive Box 3 cabling

Drive Box 4 cabling

Drive Box 5 cabling

Drive box cabling for boxes 1-2

Drive box cabling for boxes 4-5

Drive box cabling for boxes 1-5

Drive Box 1 cabling

2 SFF Box 1 x4 NVMe: direct attach (1 CPU)

This cable routing is compatible with a single-processor configuration.

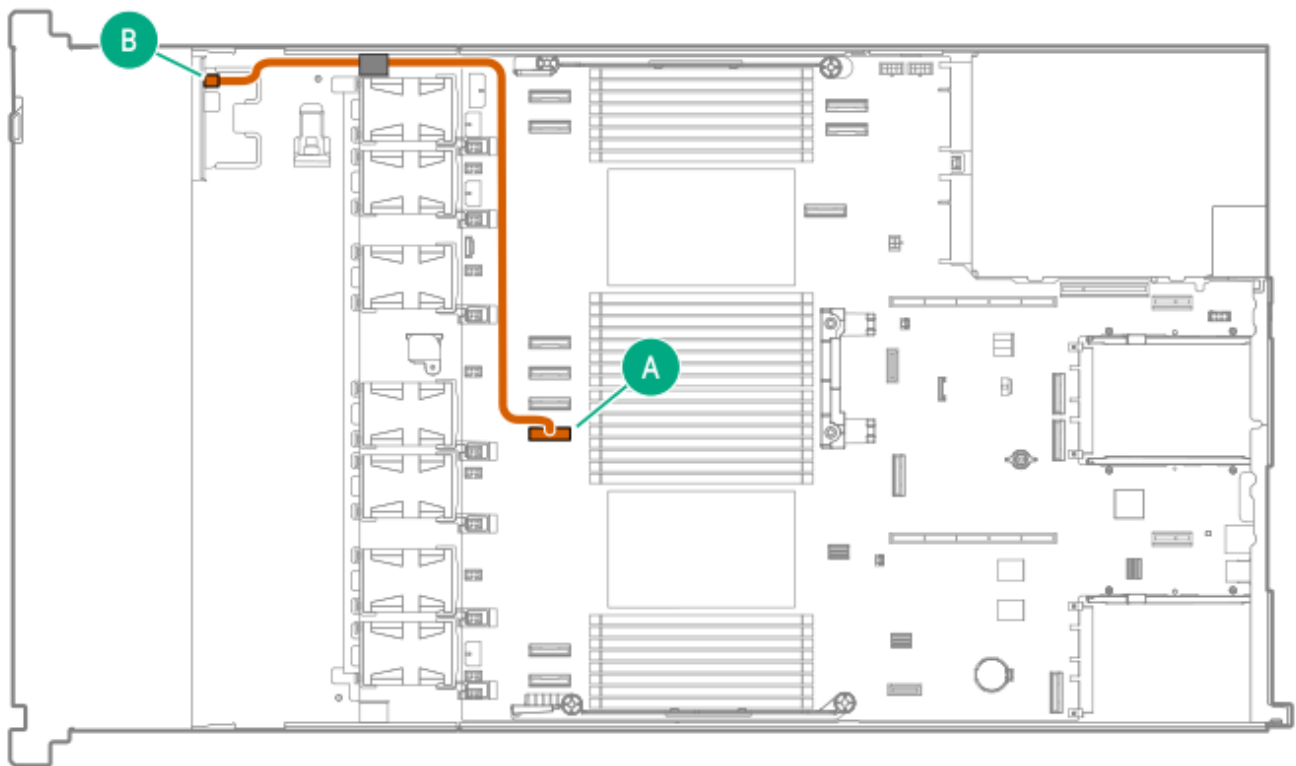

Cable part number	Color	From	To
P75568-001	Orange	Drive backplane	MCIO port 3

2 SFF Box 1 x4 NVMe: Direct attach



Cable part number	Color	From	To
P75317-001	Orange	Box 1 and 2: Drive backplane	MCI0 port 5

2 SFF Box 1 x4 NVMe: type-p controller

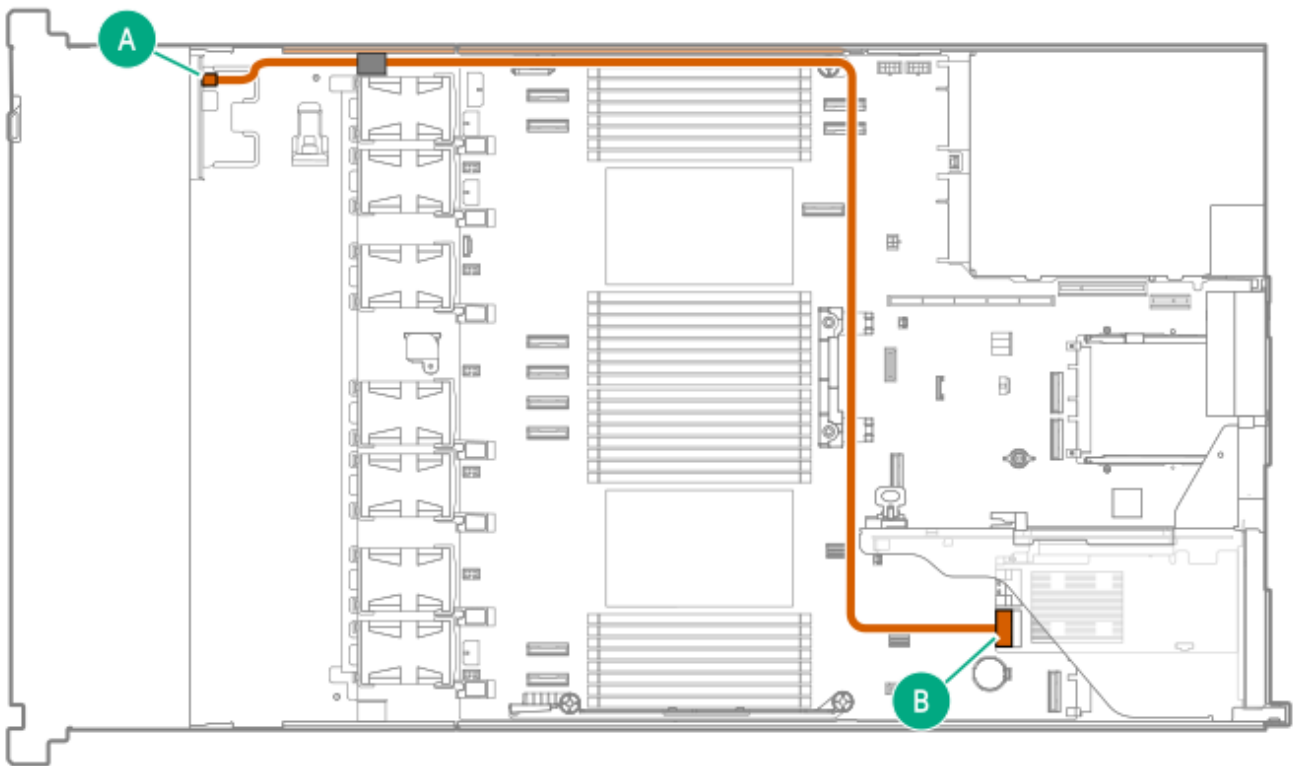

Cable part number	Color	From	To
P75590-001	Orange	Drive backplane	Primary type-p controller Port 1i

2 SFF Box 1 x4 NVMe: type-p controller in Slot 3

This configuration supports the closed-loop liquid cooling kit.



Cable part number	Color	From	To
P75590-001	Orange	Drive backplane	Slot 3 type-p controller Port 1i

Drive Box 3 cabling

2 SFF Box 3 x4 NVMe: direct attach cable and CPU1-to-OCP-B cable (1 CPU)

This cable routing is compatible with a single-processor configuration.



Cable part number	Color	From	To
P75567-001	Orange	Drive backplane	MCIO port 1
P74889-001	Blue	OCP B internal port 1	MCIO port 12

2 SFF Box 3 x4 NVMe: type-o controller in Slot 14 OCP A (1 CPU)

This cable routing is compatible with a single-processor configuration.

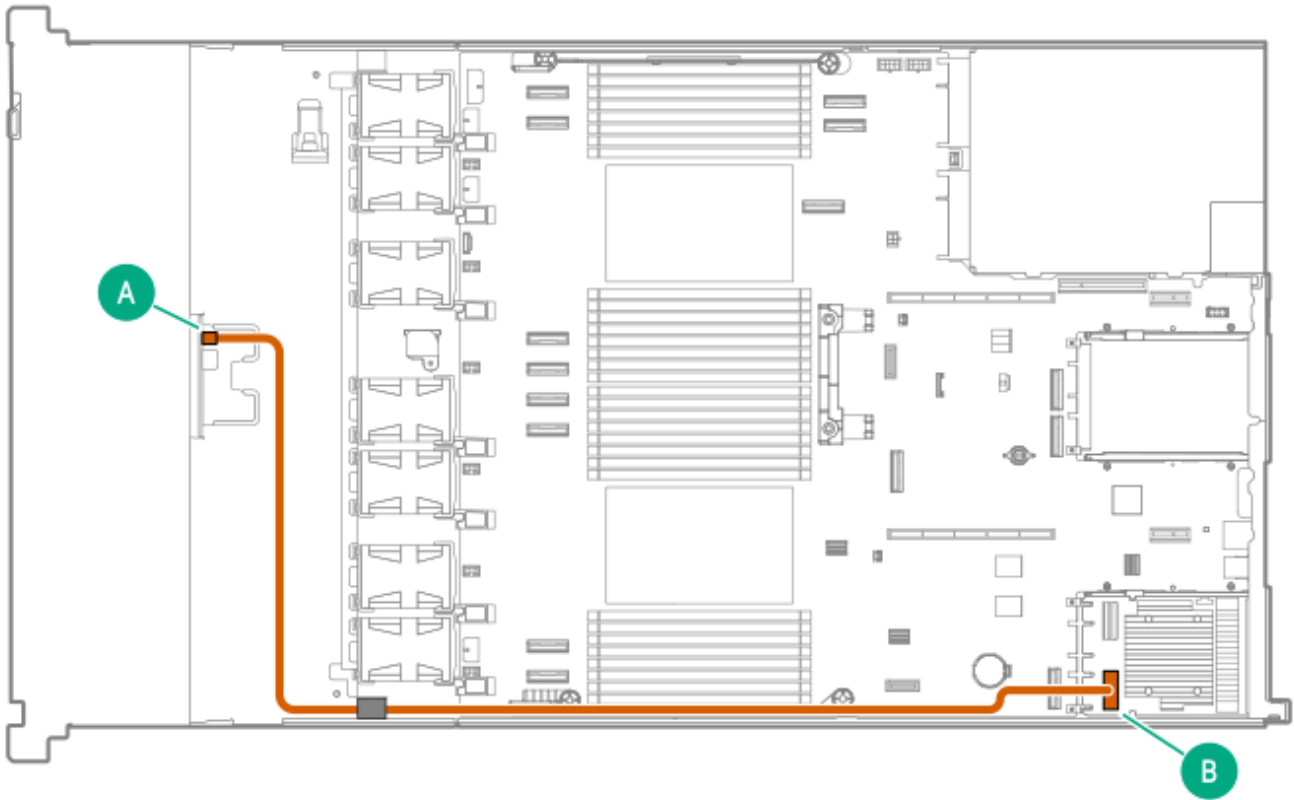

Cable part number	Color	From	To
P75589-001	Orange	Drive backplane	Slot 14 OCP A type-o controller Port 1i

2 SFF Box 3 x4 NVMe: direct attach

This cable routing supports both single-processor and dual-processor configurations.

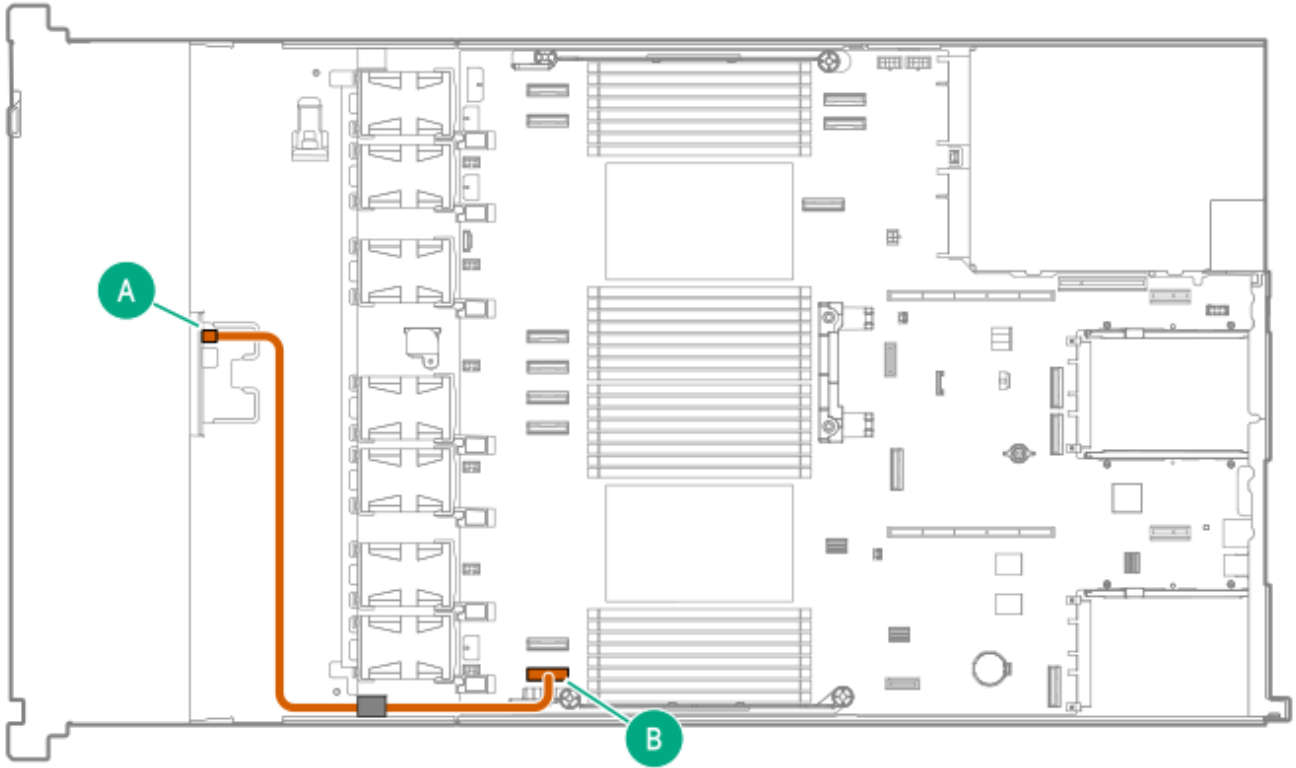

Cable part number	Color	From	To
P75278-001	Orange	Drive backplane	MCIO port 1

2 SFF Box 3 x4 NVMe: type-o controller in Slot 15 OCP B

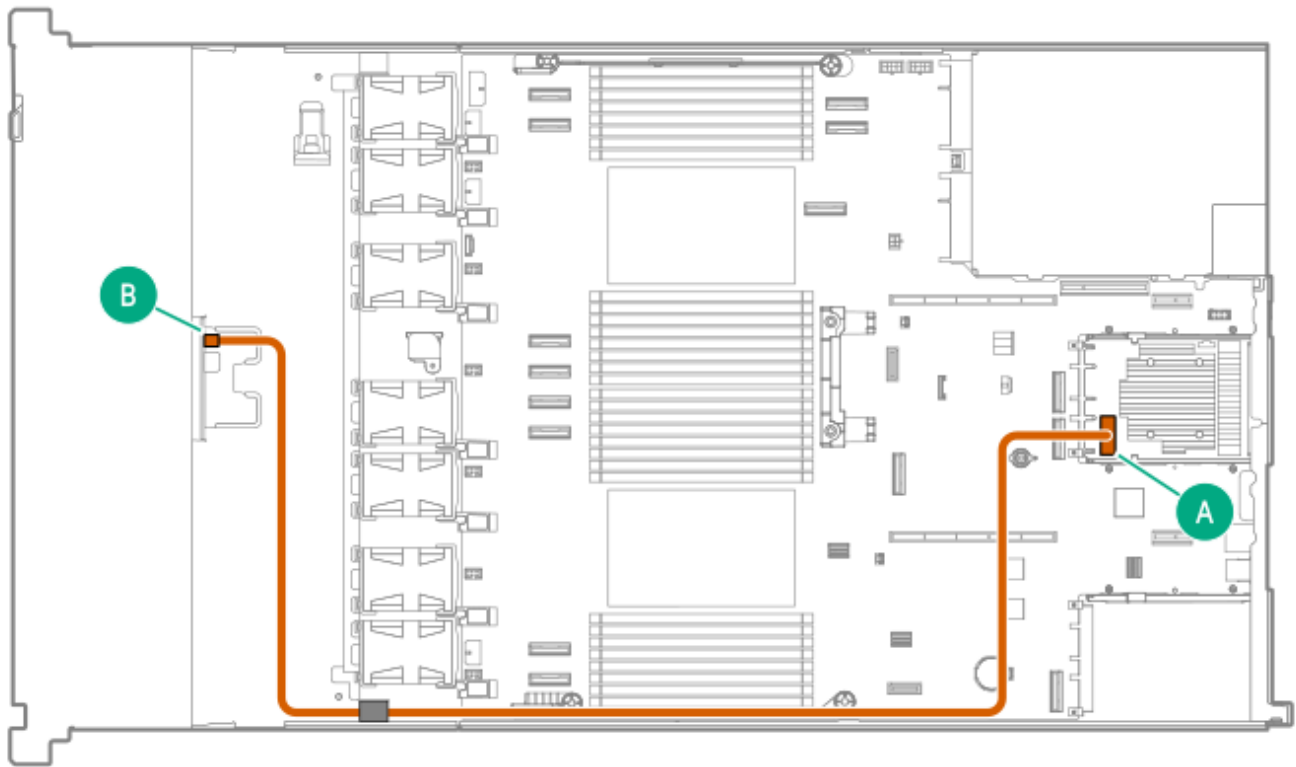

Cable part number	Color	From	To
P75587-001	Orange	Drive backplane	Slot 15 OCP B type-o controller Port 1i

2 SFF Box 3 x4 NVMe: type-p controller in Slot 1

MR416i-p / MR216i-p / MR408i-p in Slot 1

- Air-cooled system

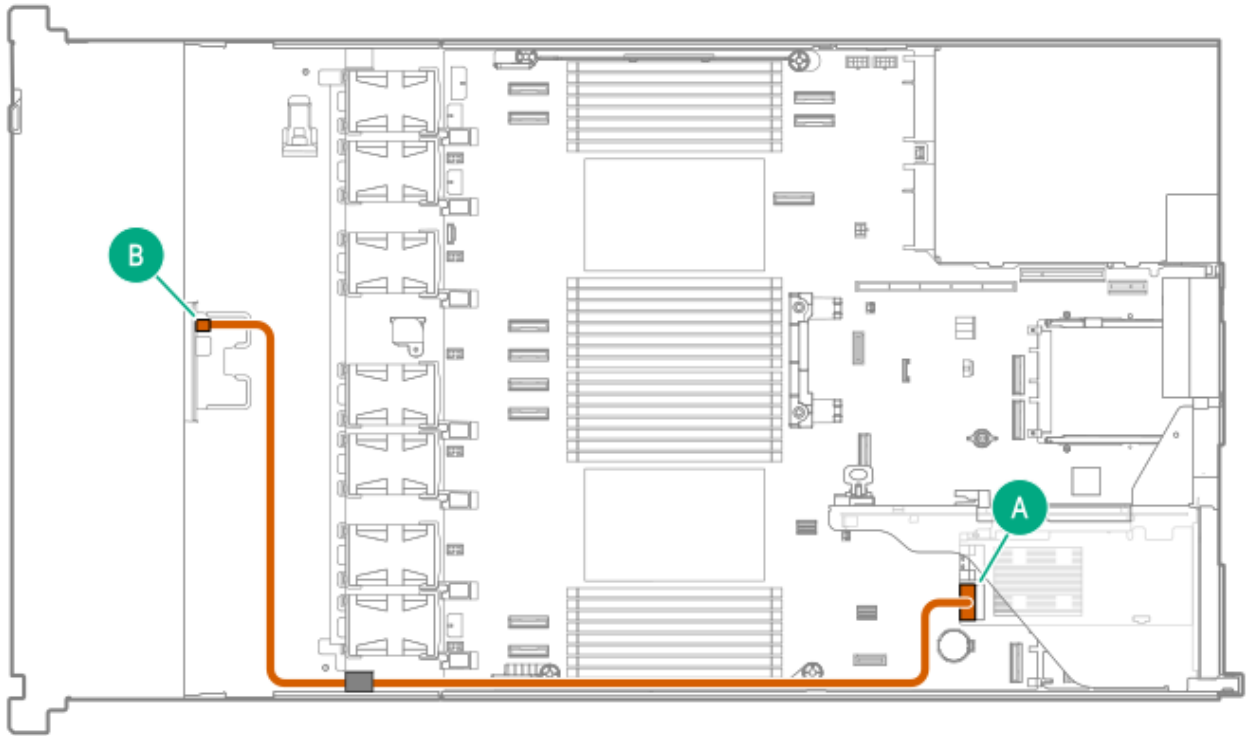

- Liquid-cooled system (CLLC)

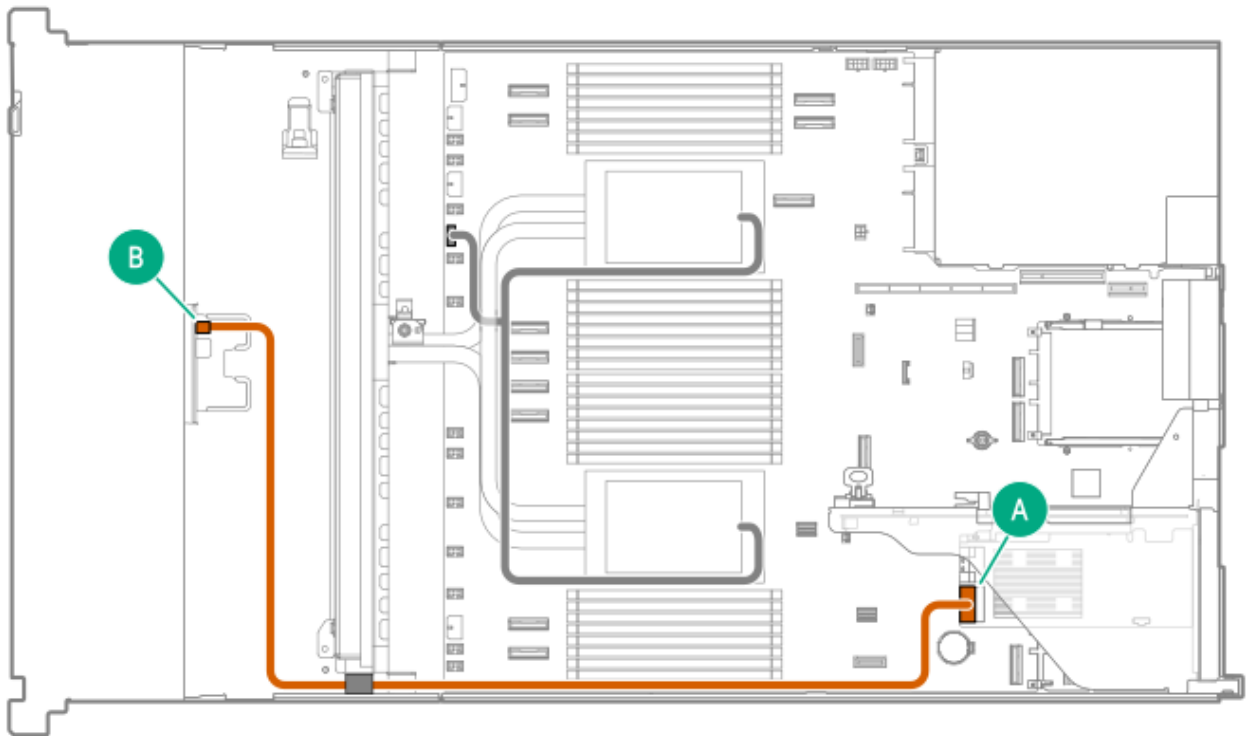

Cable part number	Color	From	To
P75590-001	Orange	Drive backplane	Primary type-p controller Port 1i

Drive Box 4 cabling

2 SFF Box 4 x4 NVMe: direct attach (1 CPU)

This cable routing is compatible with a single-processor configuration.

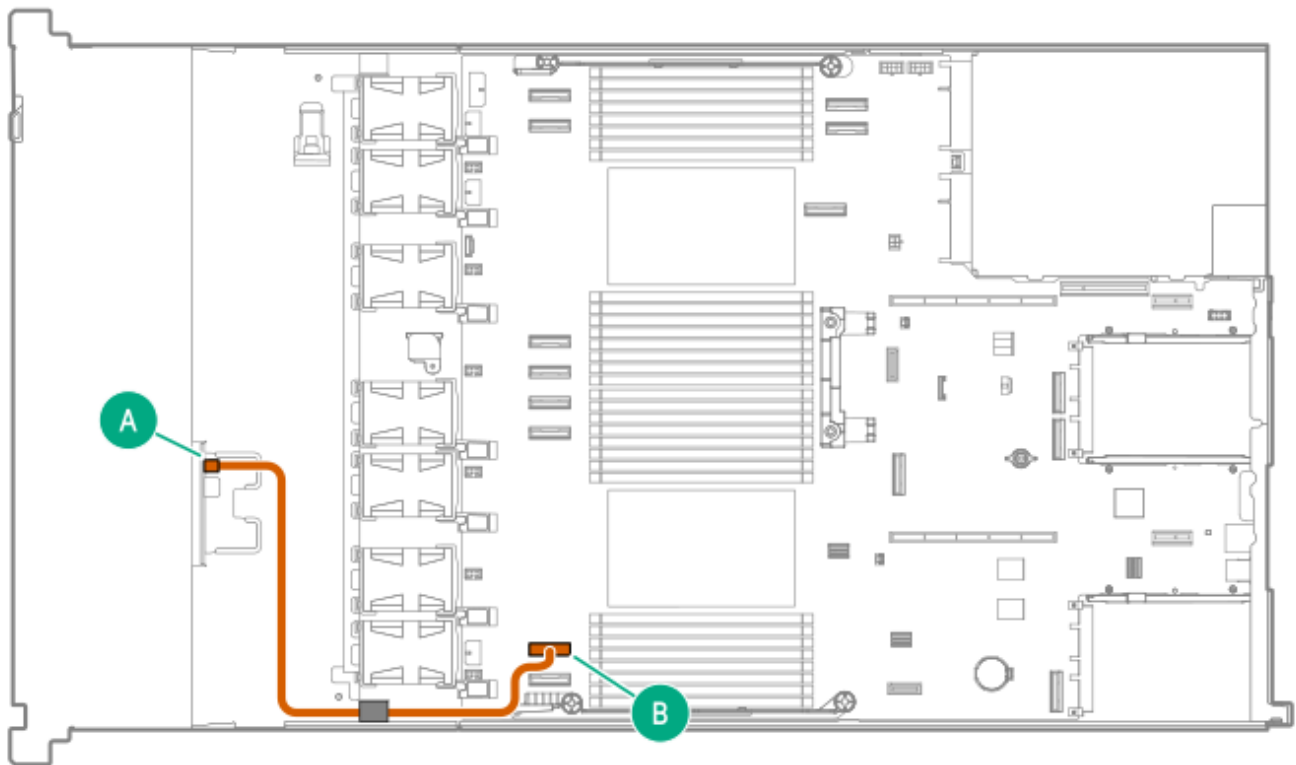

Cable part number	Color	From	To
P75317-001	Orange	Drive backplane	MCIO port 2

2 SFF Box 4 x4 NVMe: direct attach

This cable routing is compatible with a dual-processor configuration.

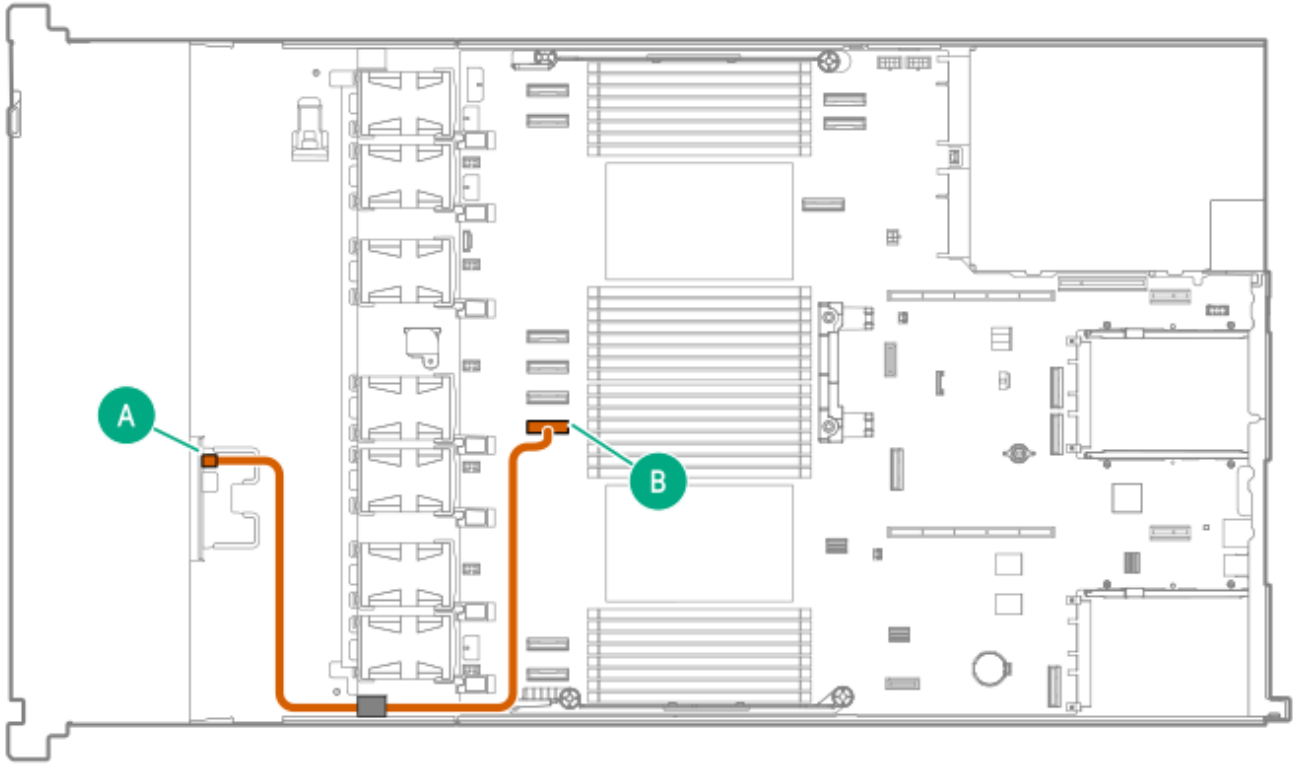

Cable part number	Color	From	To
P75567-001	Orange	Drive backplane	MCIO port 3

2 SFF Box 4 x4 NVMe: type-o controller in Slot 14 OCP A

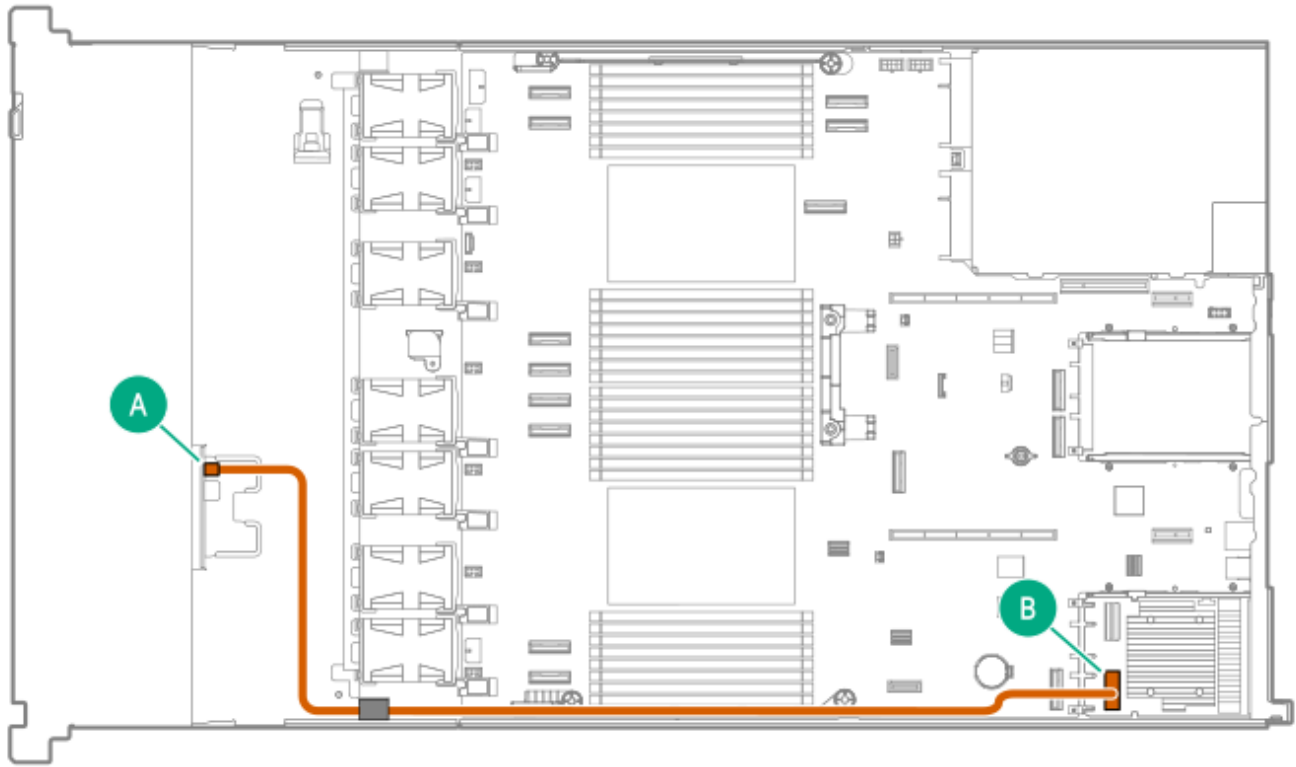

Cable part number	Color	From	To
P75589-001	Orange	Drive backplane	Slot 14 OCP A type-o controller Port 1i

2 SFF Box 4 x4 NVMe: type-p controller in Slot 1

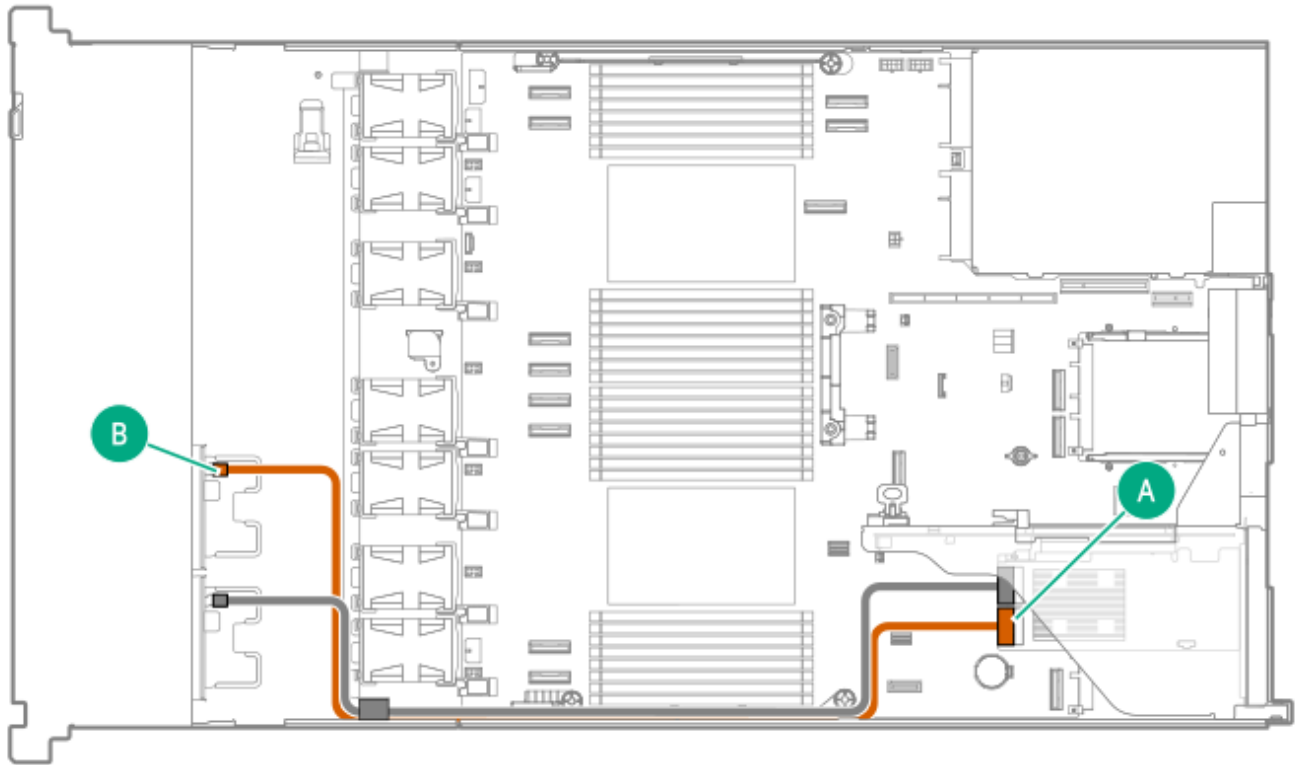

Cable part number	Color	From	To
P76443-001	Orange	Drive backplane	Primary type-p controller Port 1i

2 SFF Box 4 x4: type-o controller in Slot 15 OCP B

This configuration supports the closed-loop liquid cooling kit.

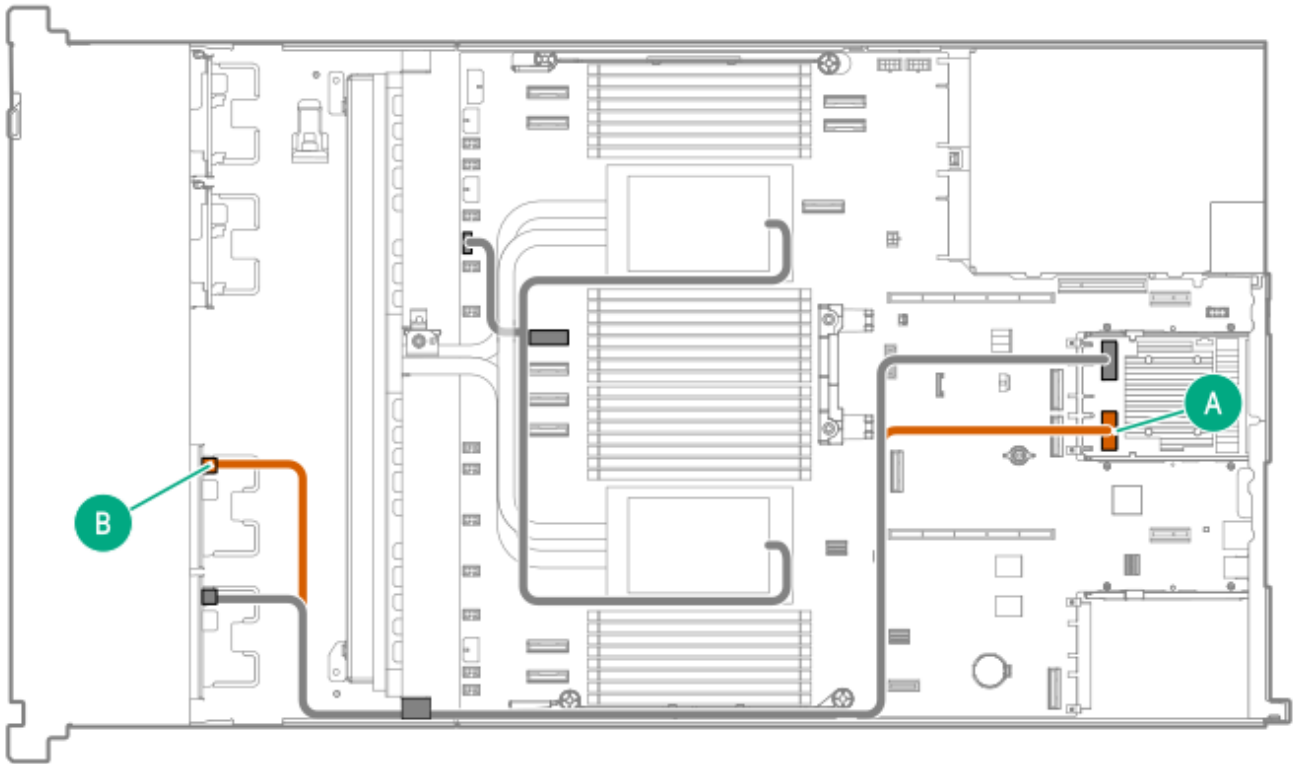

Cable part number	Color	From	To
P75589-001	Orange	Drive backplane	Slot 15 OCP B type-o controller Port 1i

2 SFF Box 4 x4 NVMe: type-p controller in Slot 2

This configuration supports the closed-loop liquid cooling kit.

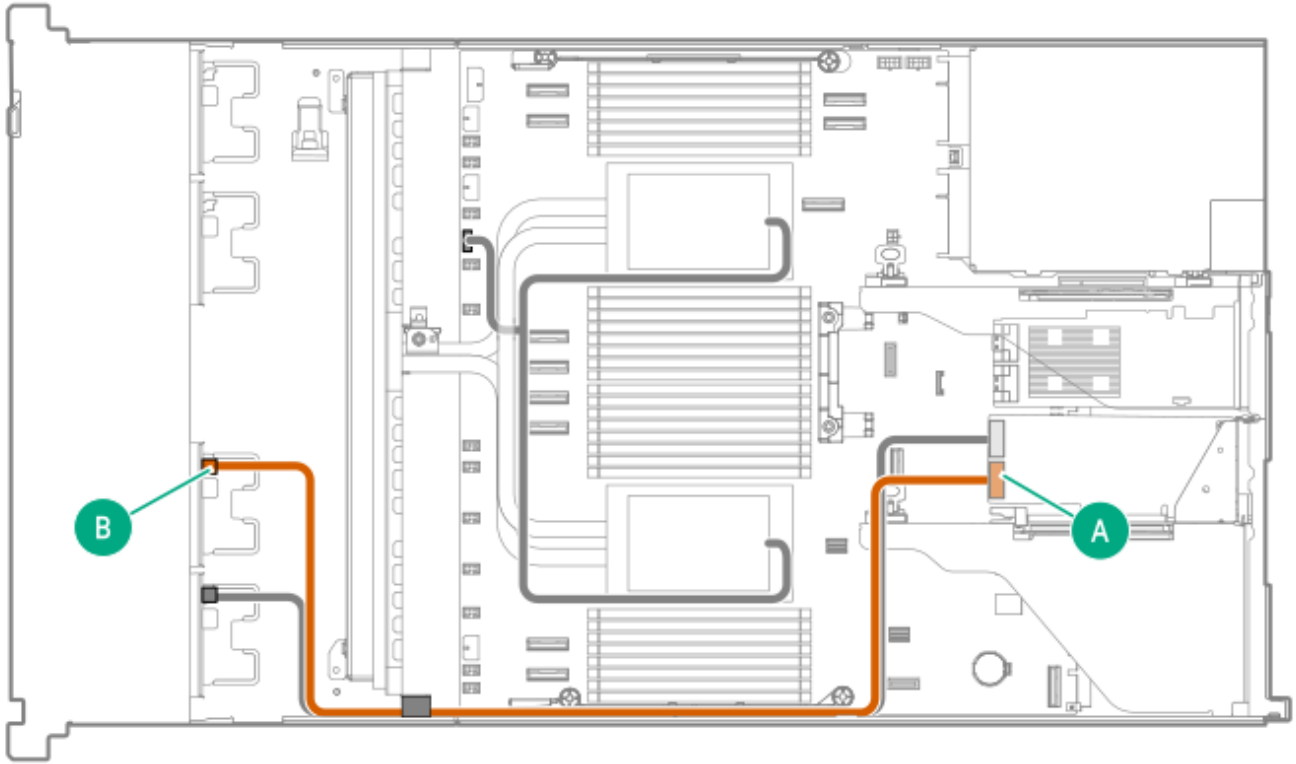

Cable part number	Color	From	To
P76443-001	Orange	Drive backplane	Slot 2 type-p controller Port 2i

Drive box cabling for boxes 1-2

4 SFF Boxes 1-2 x4 (x2 BW) NVMe: type-p controller in Slot 1

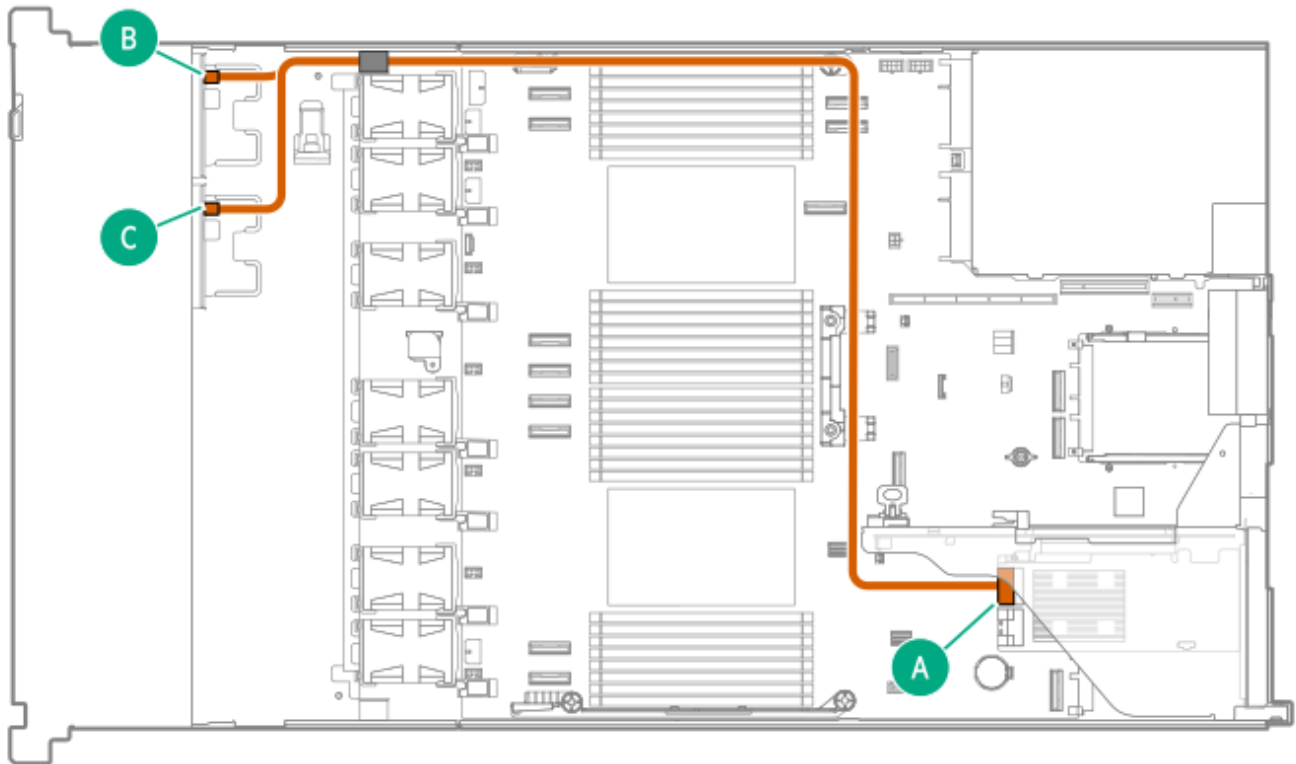

Cable part number	Color	From	To
P75593-001	Orange	Boxes 1-2: Drive backplane	Slot 1 type-p controller Port 2i

4 SFF Boxes 1-2 x4 (x2 BW) NVMe: type-p controller in Slot 2

This configuration supports the closed-loop liquid cooling kit.



Cable part number	Color	From	To
P75593-001	Orange	Boxes 1–2: Drive backplane	Slot 2 type-p controller Port 1i

4 SFF Boxes 1–2 (x2 BW) NVMe: type-o controller in Slot 14 OCP A

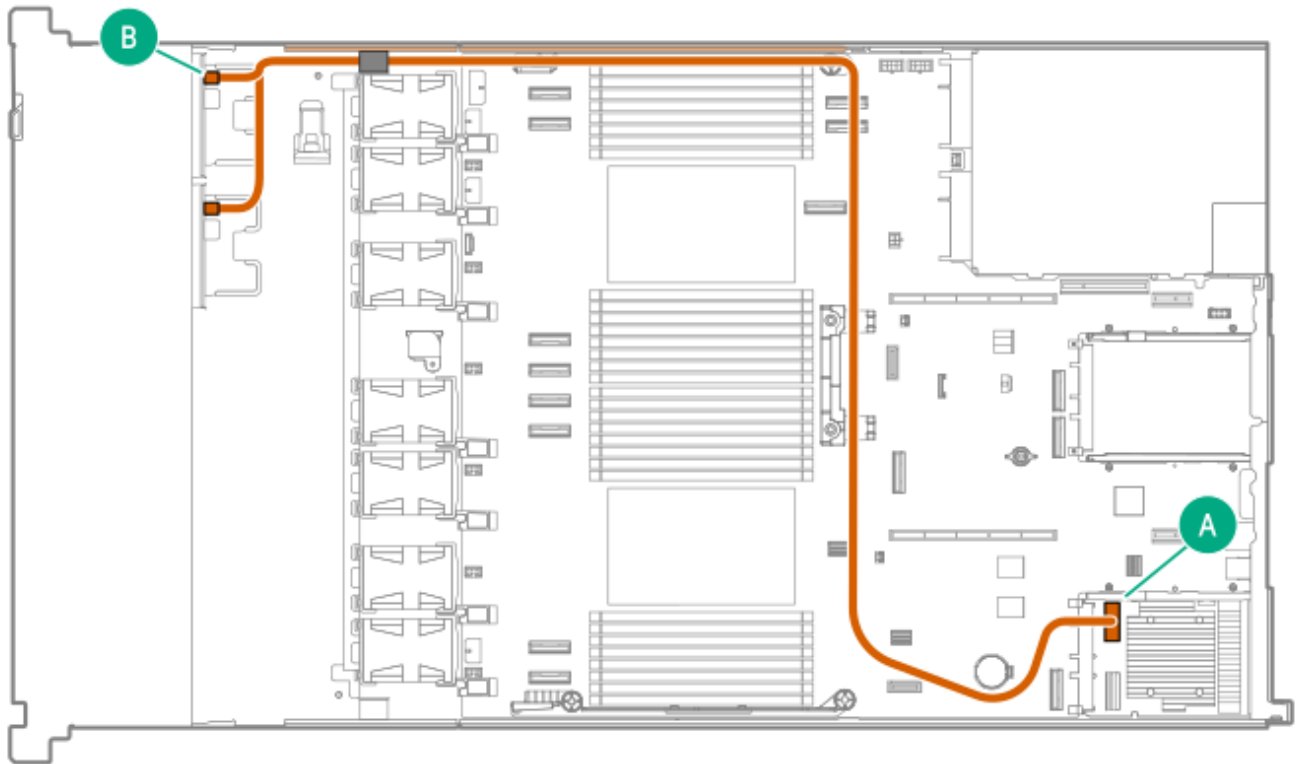

Cable part number	Color	From	To
P75571-001	Orange	Boxes 1–2: Drive backplane	Slot 14 OCP A type-o controller Port 2i

4 SFF Boxes 1-2 x4 (x2 BW) NVMe: type-o controller in Slot 14 OCP A

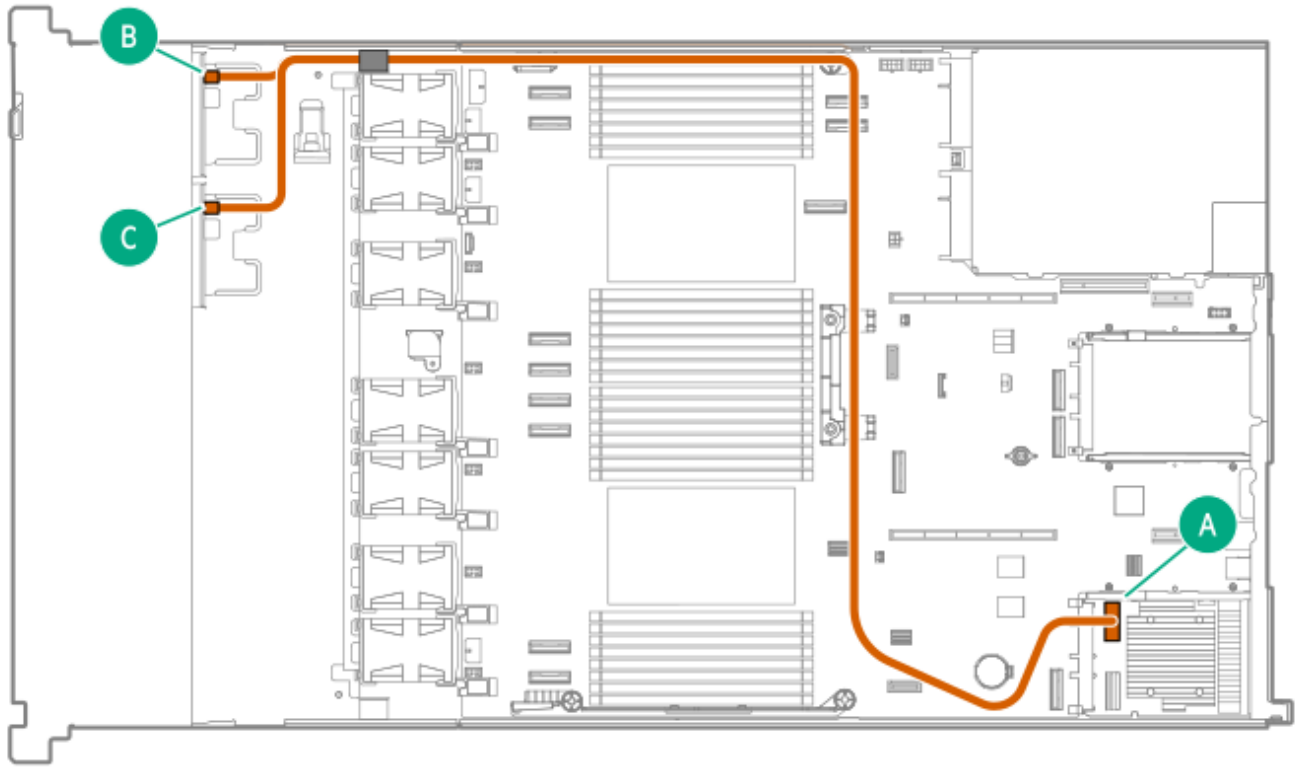

Cable part number	Color	From	To
P75571-001	Orange	Boxes 1-2: Drive back plane	Slot 14 OCP A type-o controller Port 2i

4 SFF Boxes 1-2 x4 (x2 BW) NVMe: type-o controller in Slot 15 OCP B

This configuration supports the closed-loop liquid cooling kit.

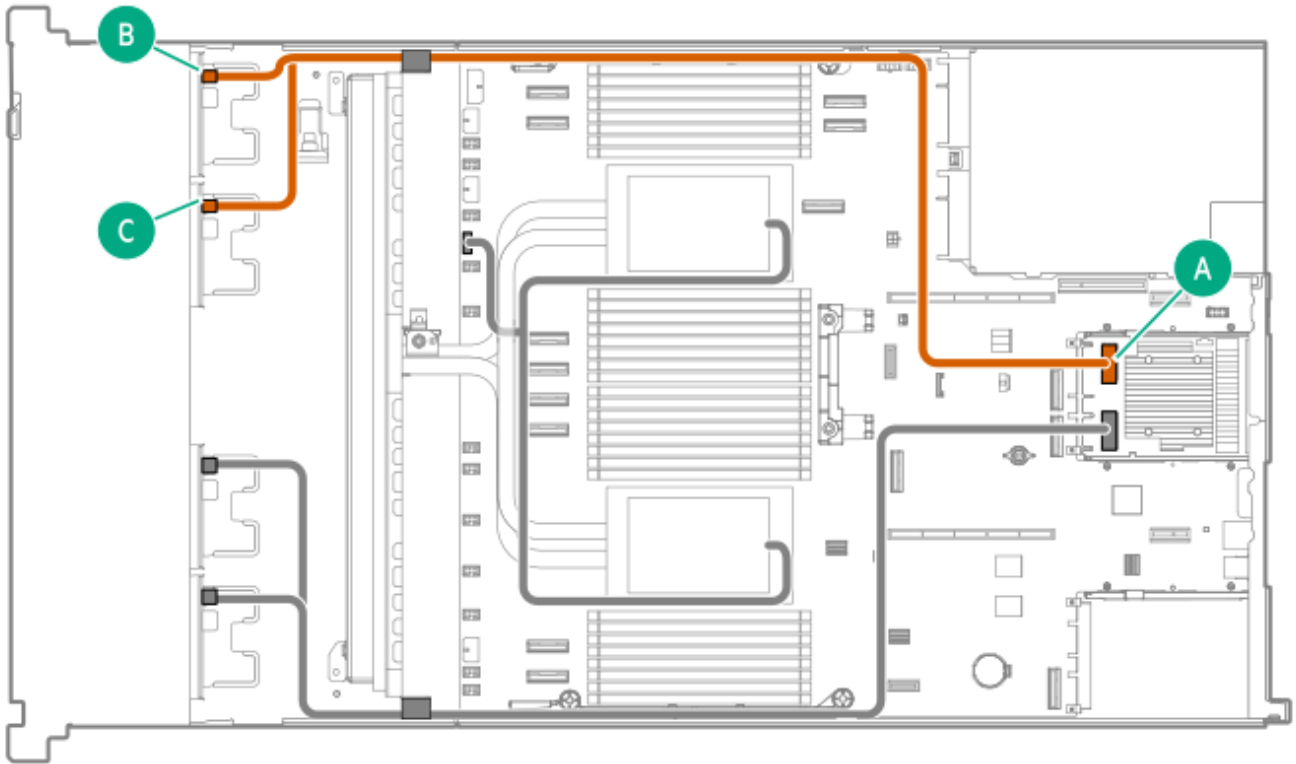

Cable part number	Color	From	To
P75573-001	Orange	Boxes 1–2: Drive back plane	Slot 15 OCP B type-o controller Port 2i

4 SFF Boxes 1–2 x4 NVMe to type-p controller in Slot 1

MR932i-p:

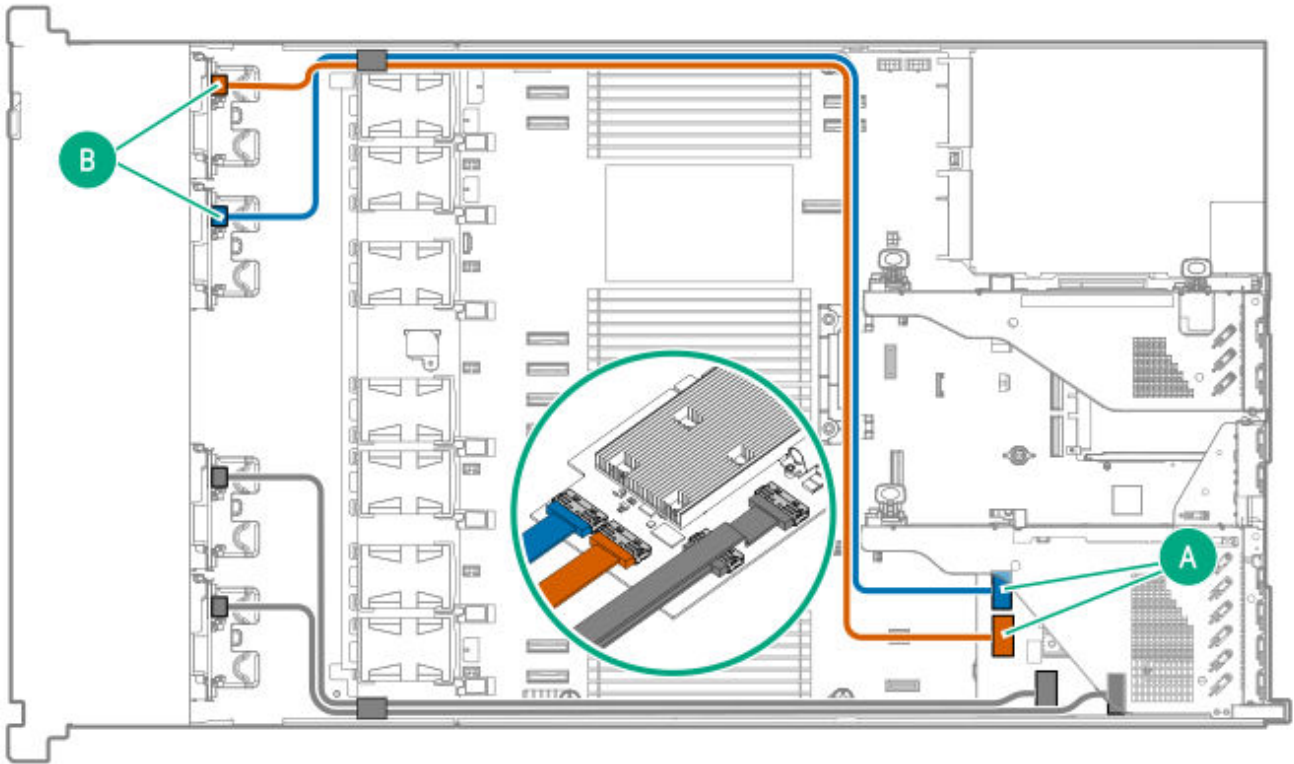

Cable part number	Color	From	To
P75318-001	Orange	Box 1: Drive backplane port	Slot 1 type-p controller Port 1i
	Blue	Box 2: Drive backplane port	Slot 1 type-p controller Port 2i

Drive box cabling for boxes 4-5

4 SFF Boxes 4-5 x4 NVMe: direct attach

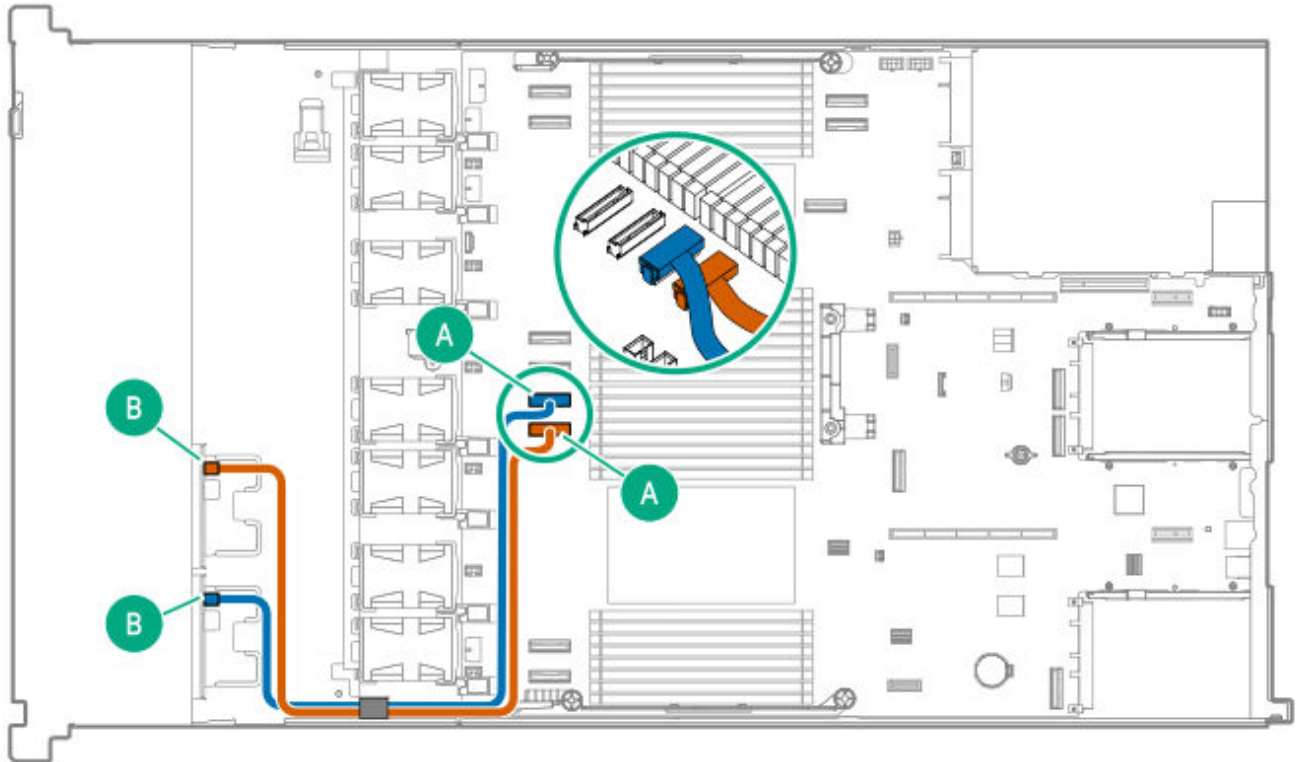

Cable part number	Color	From	To
P75567-001	Orange	Box 4: drive backplane	MCI/O port 3
P75278-001	Blue	Box 5: drive backplane	MCI/O port 4

4 SFF Boxes 4-5 x4 (x2 BW) NVMe: type-o controller in Slot 14 OCP A

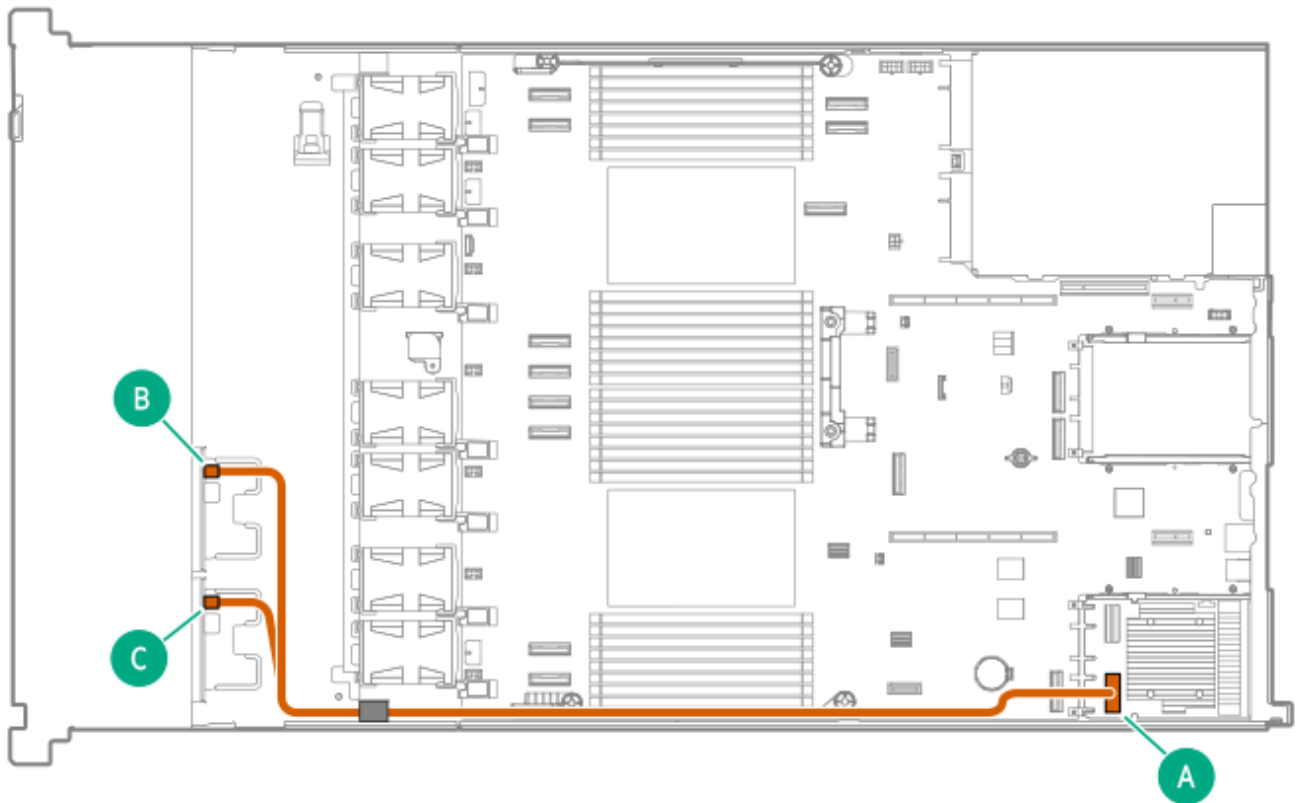

Cable part number	Color	From	To
P75573-001	Orange	Boxes 4-5: drive back plane	Slot 14 OCP A type-o controller Port 1i

4 SFF Boxes 4-5 x4 (x2 BW) NVMe: type-p controller in Slot 1

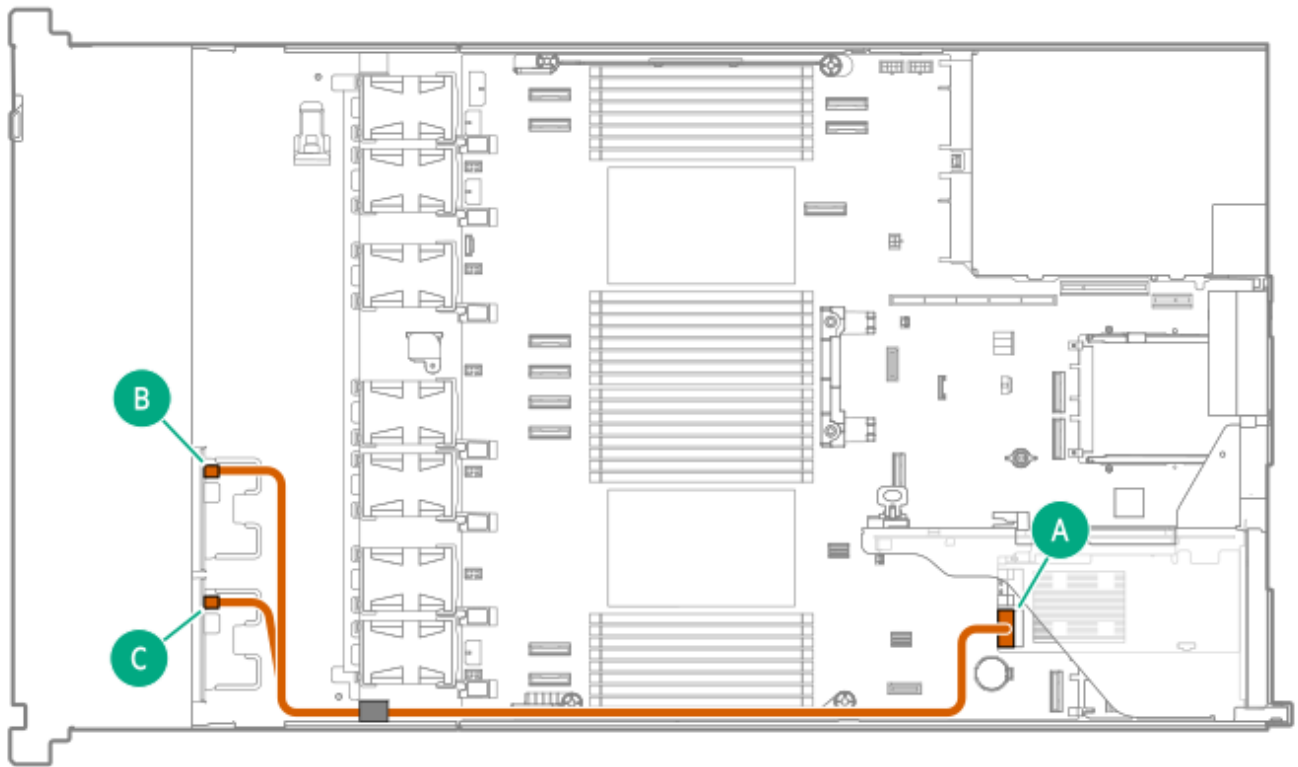

Cable part number	Color	From	To
P75572-001	Orange	Boxes 4-5: drive backplane	Slot 1 type-p controller Port 1i

4 SFF Boxes 4–5 x4 (x2 BW) NVMe: type-p controller in Slot 2

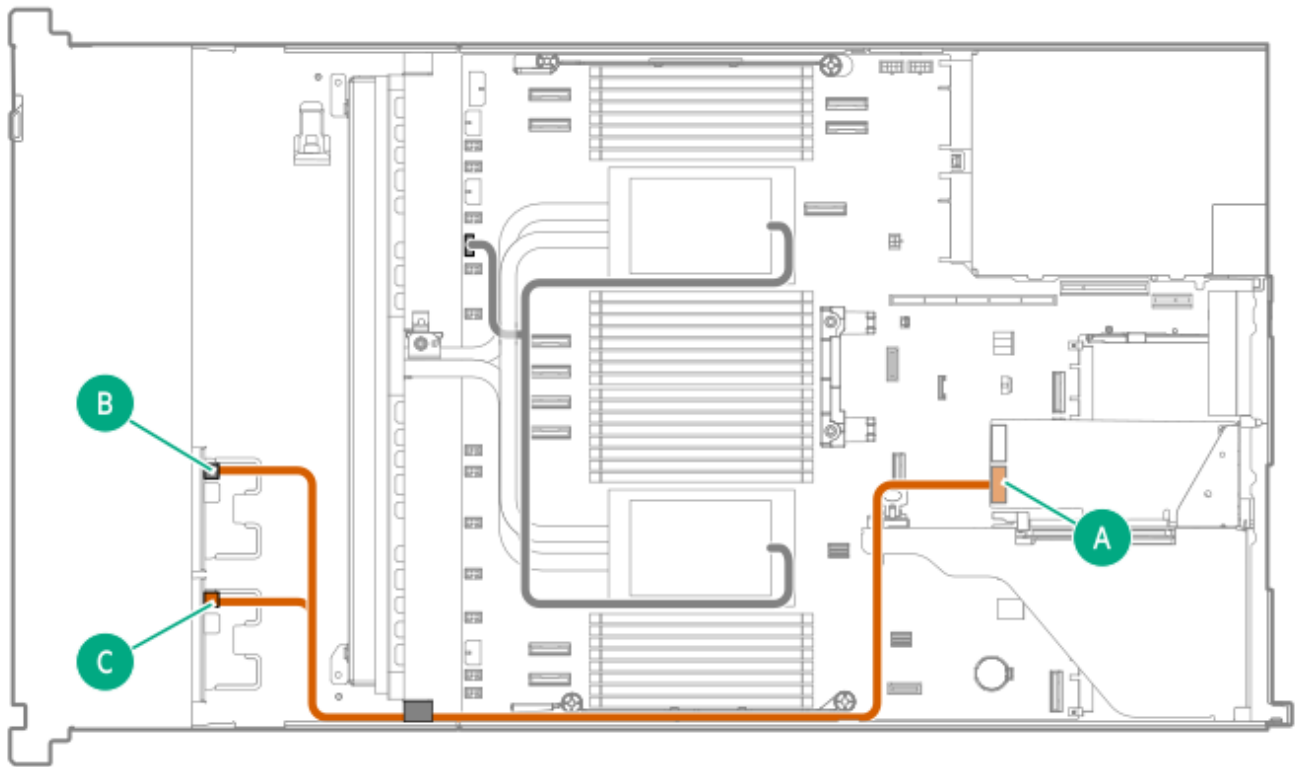

Cable part number	Color	From	To
P75572-001	Orange	Boxes 4–5: drive backplane	Slot 2 type-p controller Port 2i

4 SFF Boxes 4–5 x4 (x2 BW) NVMe: type-o controller in Slot 15 OCP B

This configuration supports the closed-loop liquid cooling kit.



Cable part number	Color	From	To
P75571-001	Orange	Boxes 4–5: drive backplane	Slot 15 OCP B type-o controller Port 2i

4 SFF Boxes 4–5 x4 NVMe: type-o controller in Slot 15 OCP B

This configuration supports the closed-loop liquid cooling kit.

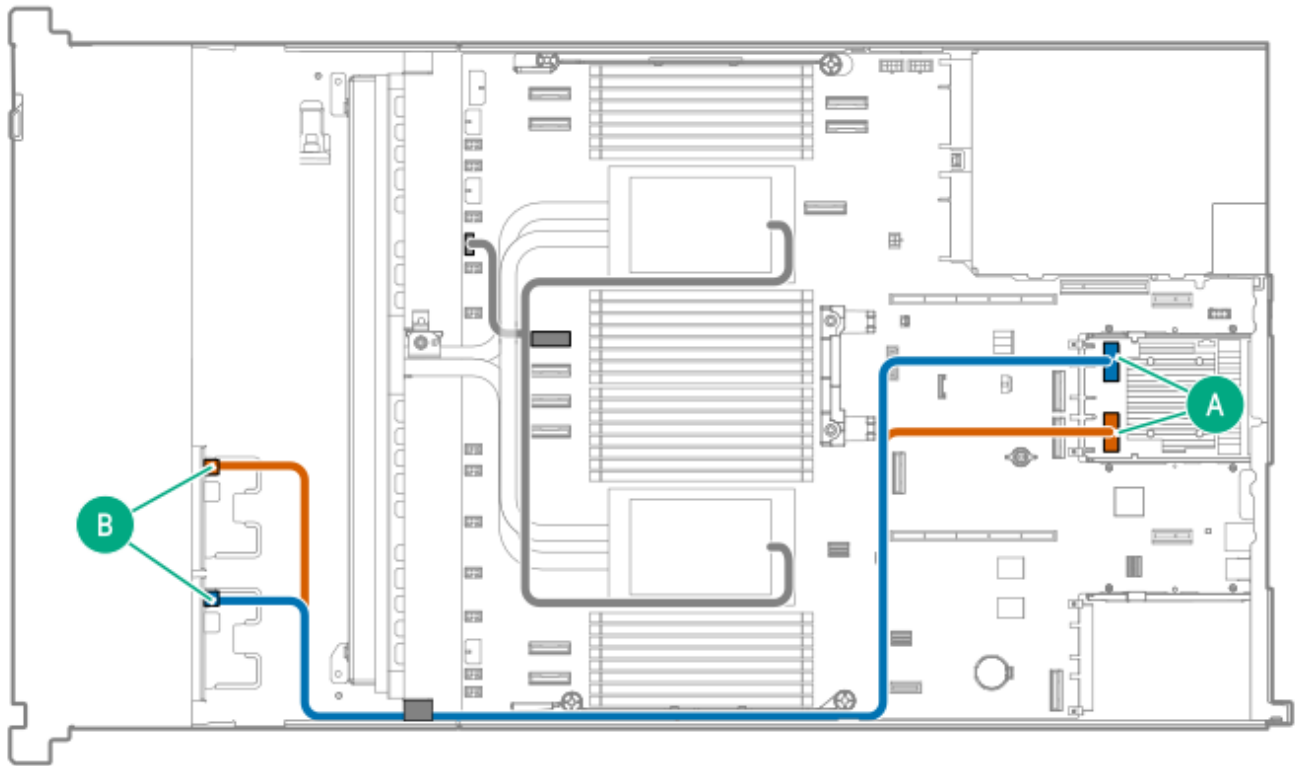

Cable part number	Color	From	To
P75589-001	Orange	Box 4: drive backplane	Slot 15 OCP B type-o controller Port 1i
	Blue	Box 5: drive backplane	Slot 15 OCP B type-o controller Port 2i

4 SFF Boxes 4–5 x4 NVMe to type-p controller in Slot 1

MR932i-p:



Cable part number	Color	From	To
P75570-001	Blue	Box 4: drive backplane port	Slot 1 type-p controller Port 4i
	Orange	Box 5: drive backplane port	Slot 1 type-p controller Port 3i

Drive box cabling for boxes 1-5

8 SFF Boxes 1-5 x4 (x2 BW) NVMe + 2 SFF x4 NVMe to type-p controller in Slot 1

MR932i-p:

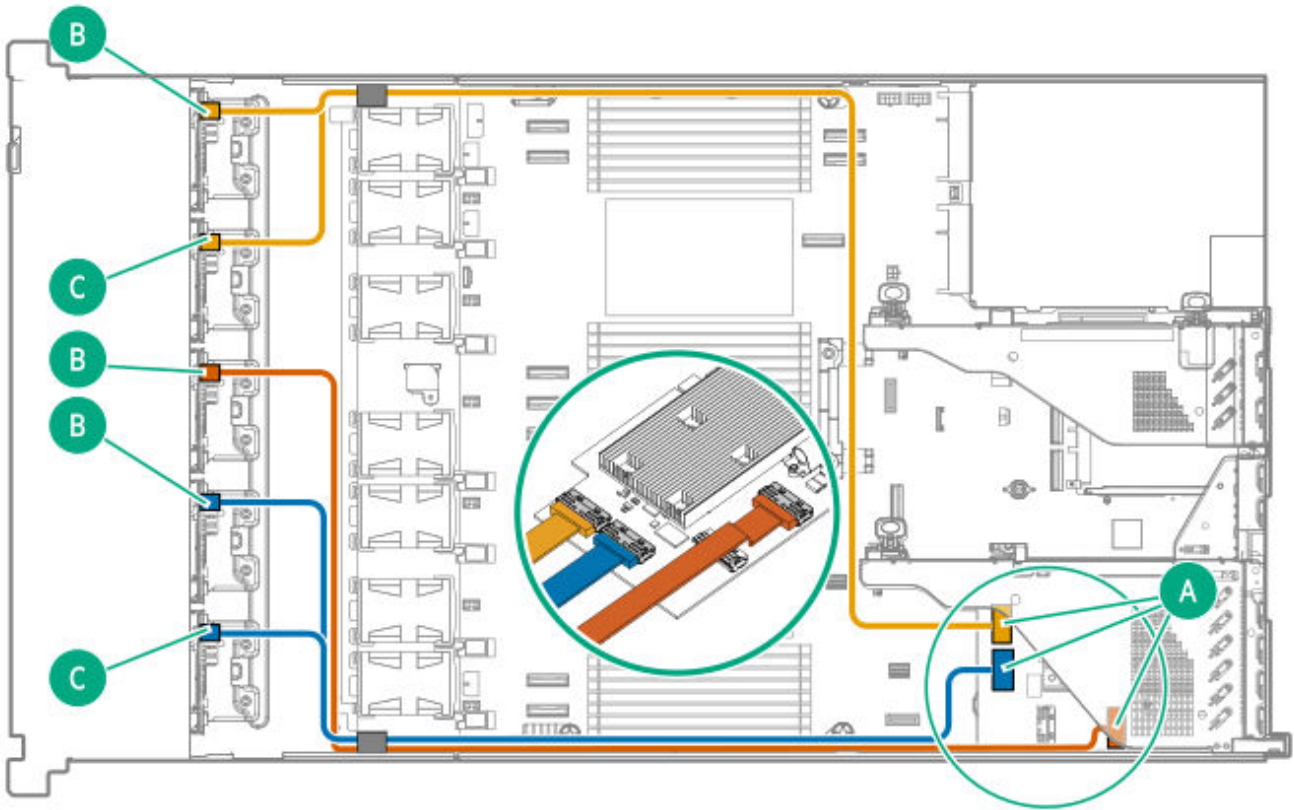

Cable part number	Color	From	To
P79152-001	Gold	Boxes 1-2: Drive backplane	Slot 1 type-p controller Port 2i

Cable part number	Color	From	To
P79153-001	Orange	Box 3: Drive backplane	Slot 1 type-p controller Port 3i
P75275-001	Blue	Boxes 4–5: Drive backplane	Slot 1 type-p controller Port 1i

Storage controller backup power cabling

The exact route of the storage controller backup power cabling will depend on:

- The riser or OCP slot where the controller is installed
- The location of the backup power cable connector on the controller

Use the following diagrams for reference only.

Storage controller backup power cabling: type-o storage controllers

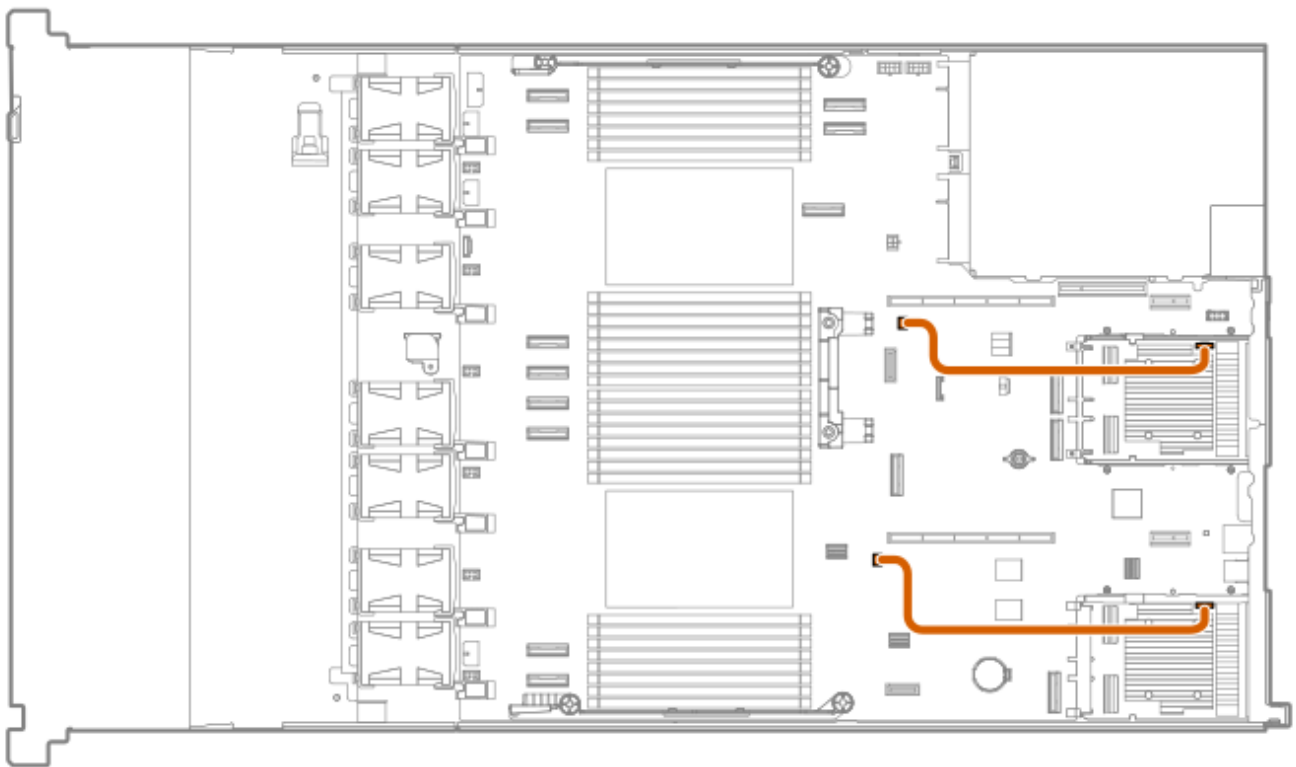

Cable color	From	To
Orange	Storage backup power connector 1	Slot 14 OROC storage backup power cable connector
	Storage backup power connector 2	Slot 15 OROC storage backup power cable connector

Storage controller backup power cabling: type-p storage controller in the primary riser



Cable color	From	To
Orange	Slot 1 primary butterfly riser: storage backup power connector	Primary type-p controller: storage backup power cable connector

Drive power cabling

4 LFF backplane power

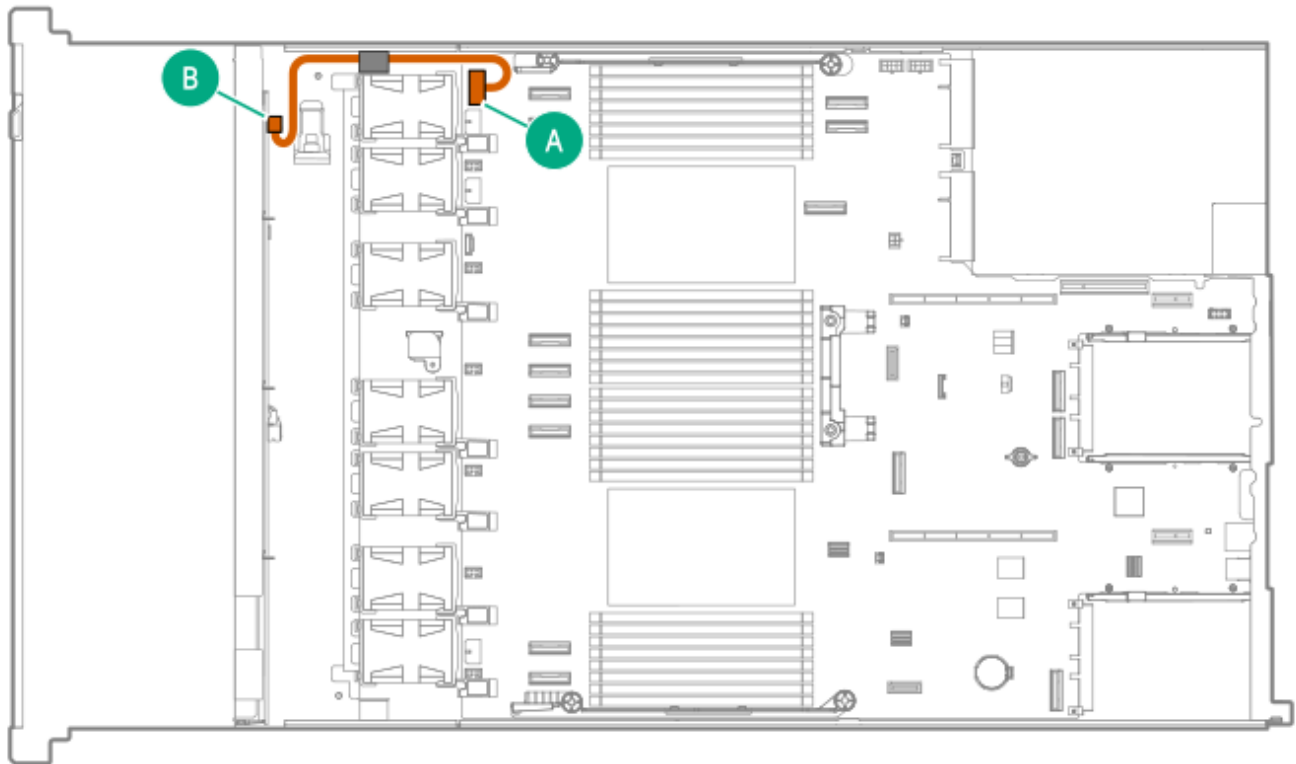

Cable part number	Color	From	To
P75565-001	Orange	4 LFF backplane	Backplane Box 1 power connector

8 SFF backplane power

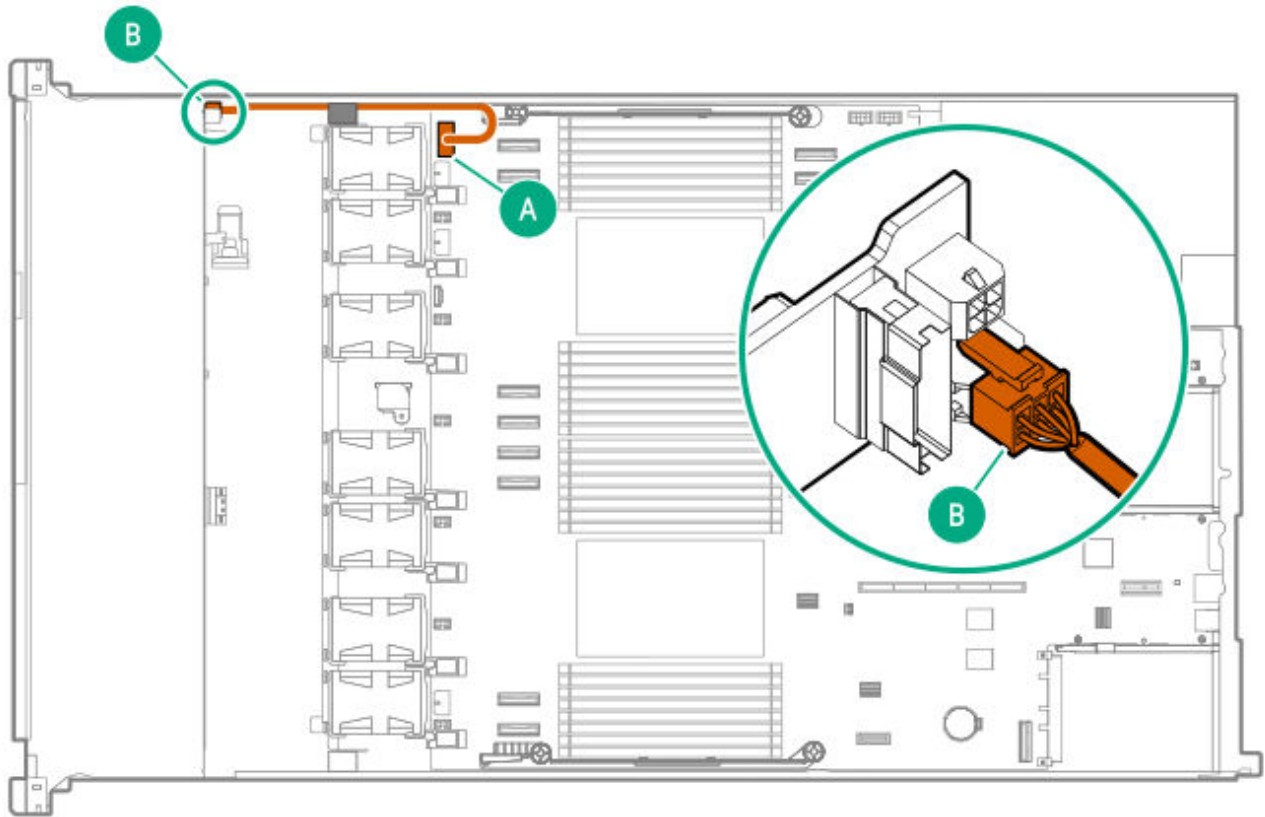

Cable part number	Color	From	To
P75566-001	Orange	8 SFF backplane	Backplane Box 1 power connector

2 SFF backplane power

This cable is supported in the 8 SFF drive configuration.

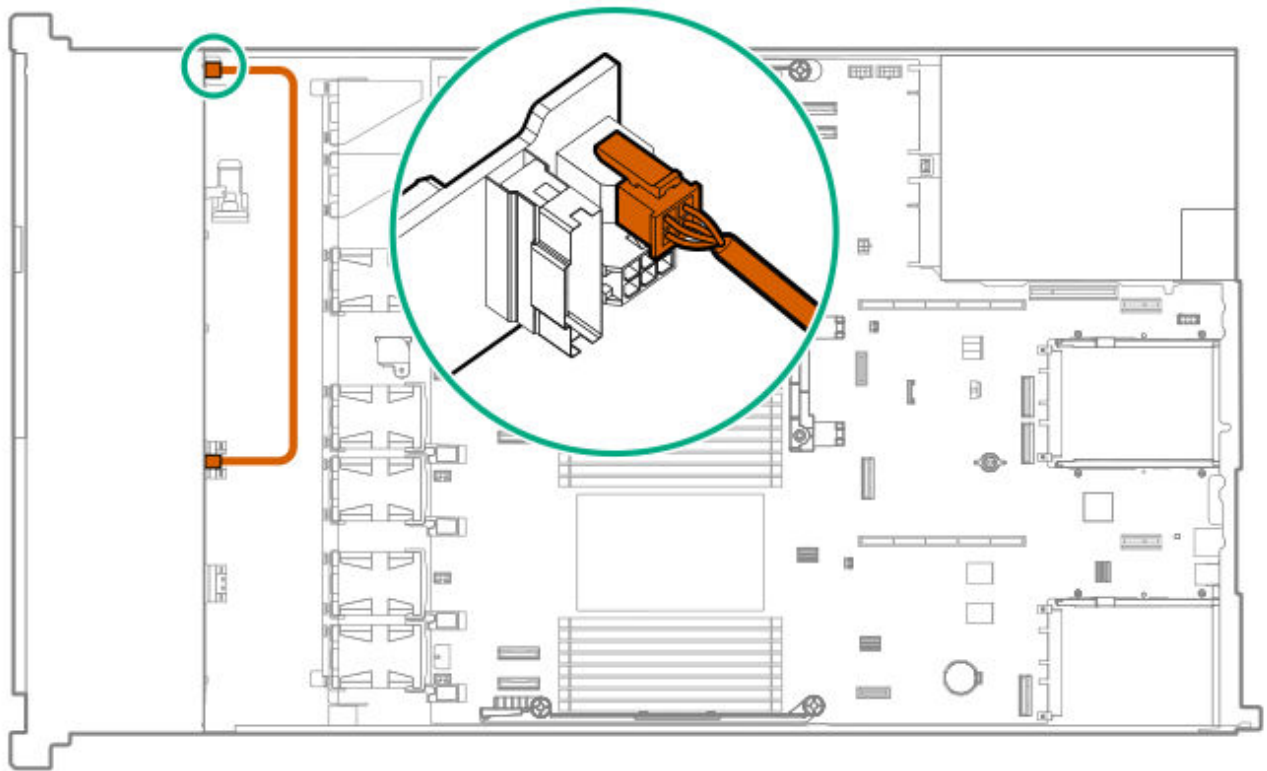

Cable part number	Color	From	To
869667-001	Orange	2 SFF backplane	8 SFF backplane

10 SFF / 20 E3.S server: Stacked 2 SFF / 4 EDSFF backplane power

This cable is supported in the 10 SFF / 20 E3.S server or servers using the mixed drive type configuration.

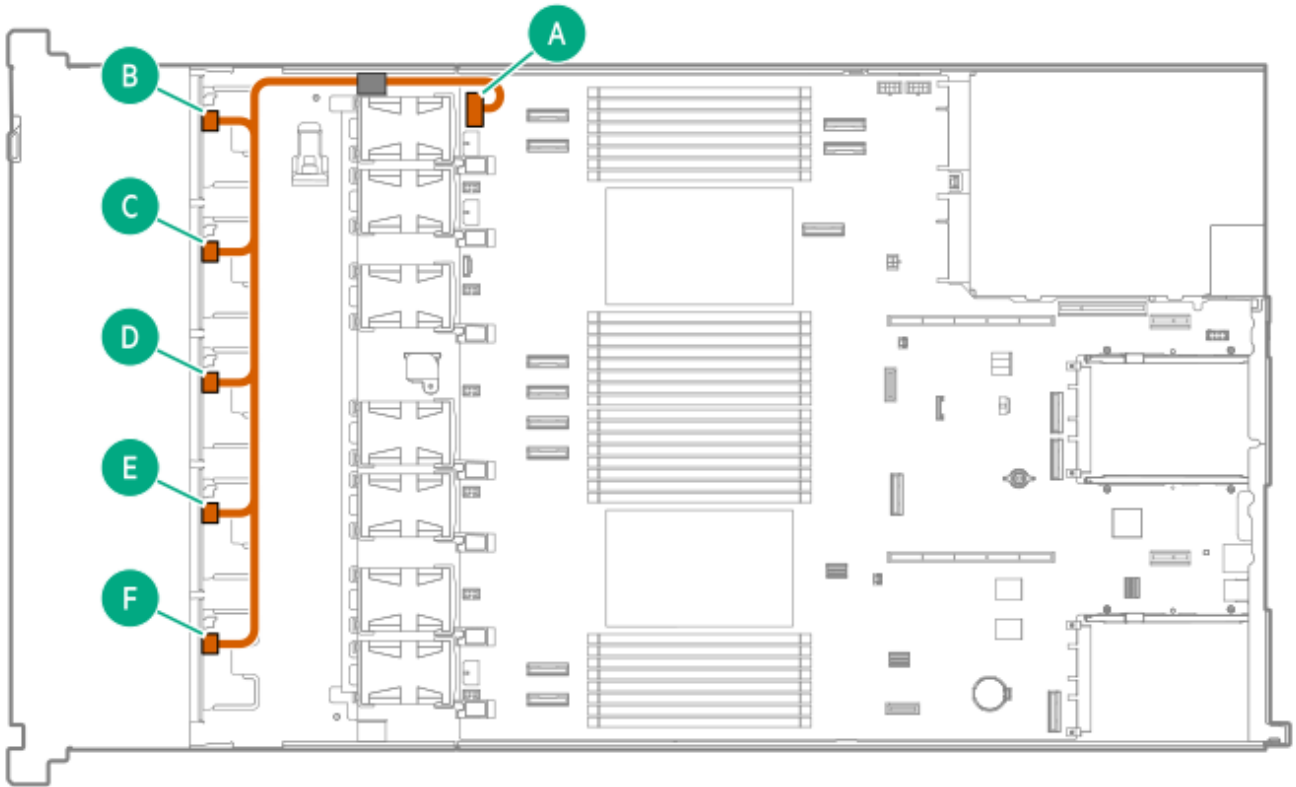

Cable part number	Color	From	To
P75316-001	Orange	SFF/ EDSFF backplane	Backplane power connector

Optical drive cabling

4 LFF drive configuration: optical drive cabling

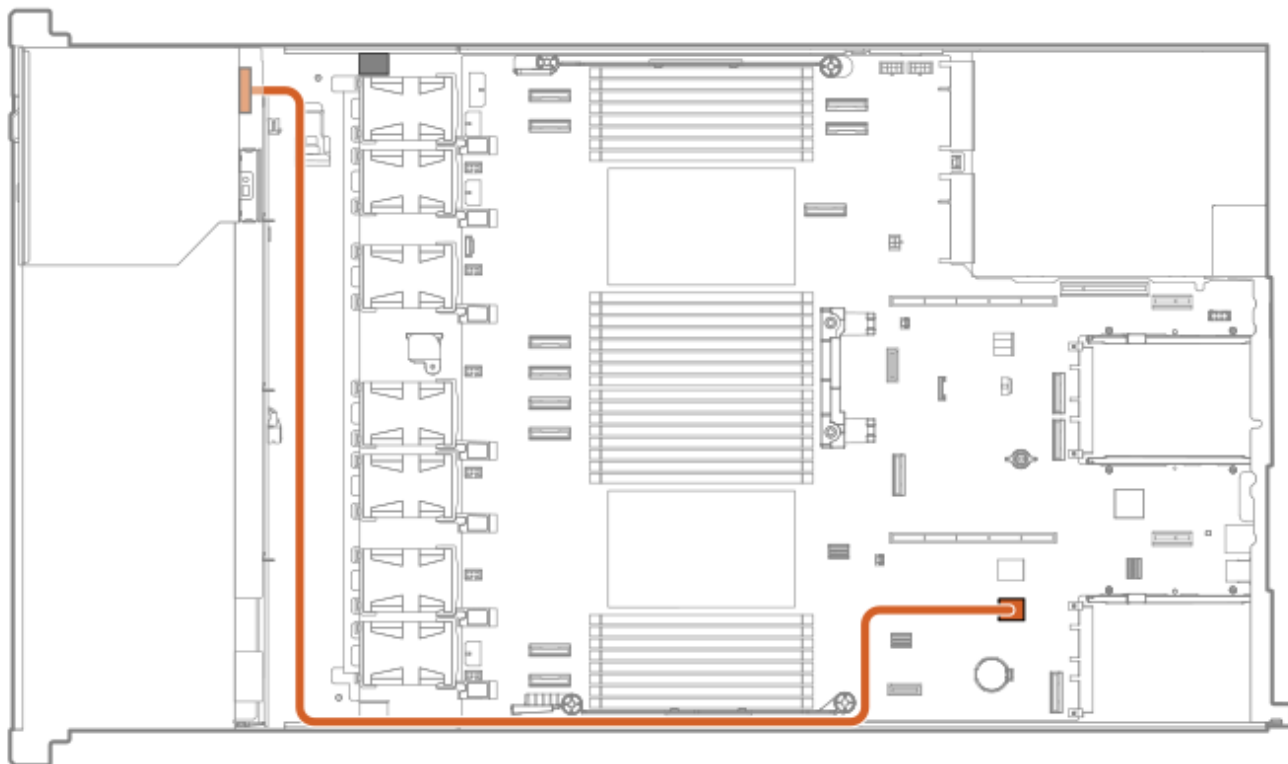

Cable part number	Color	From	To
P73776-002	Orange	Optical drive	Internal USB 3.2 Gen1 port

8 SFF drive configuration: optical drive cabling

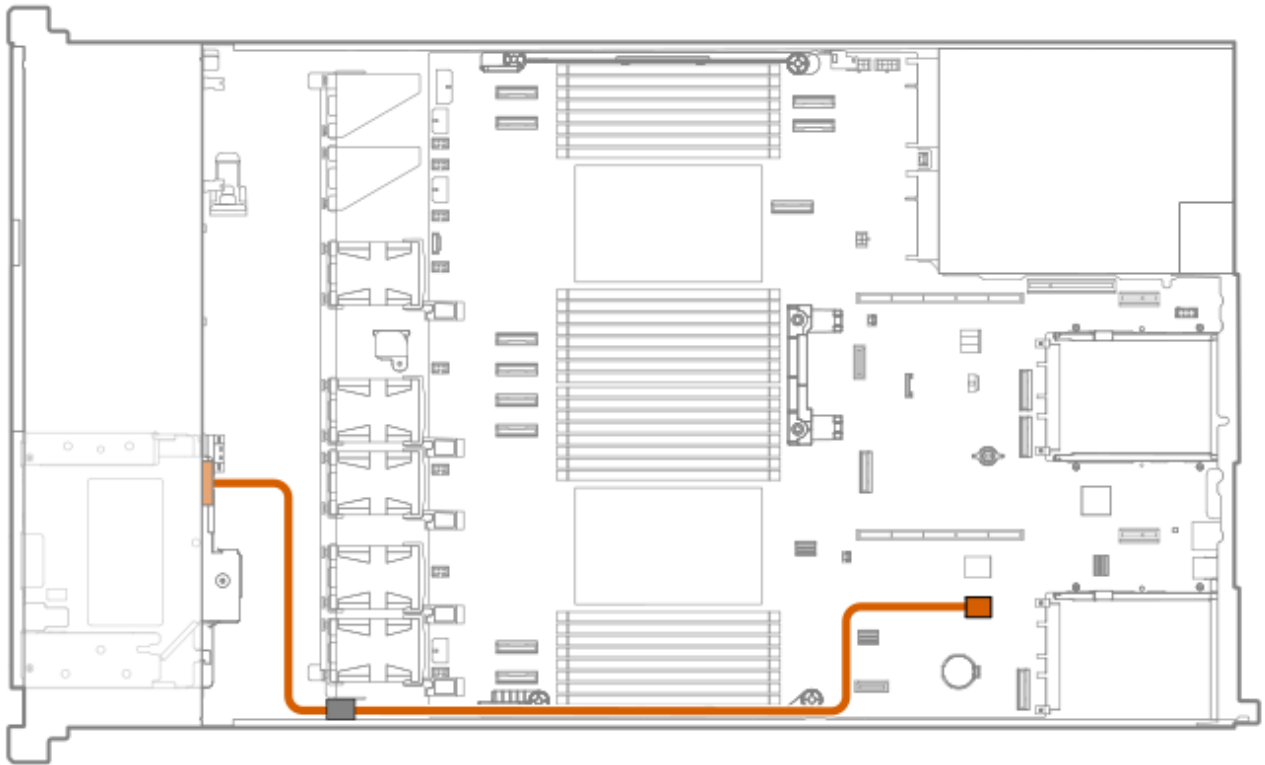

Cable part number	Color	From	To
P73776-002	Orange	Optical drive	Internal USB 3.2 Gen1 port

Mixed drive type configuration: optical drive cabling

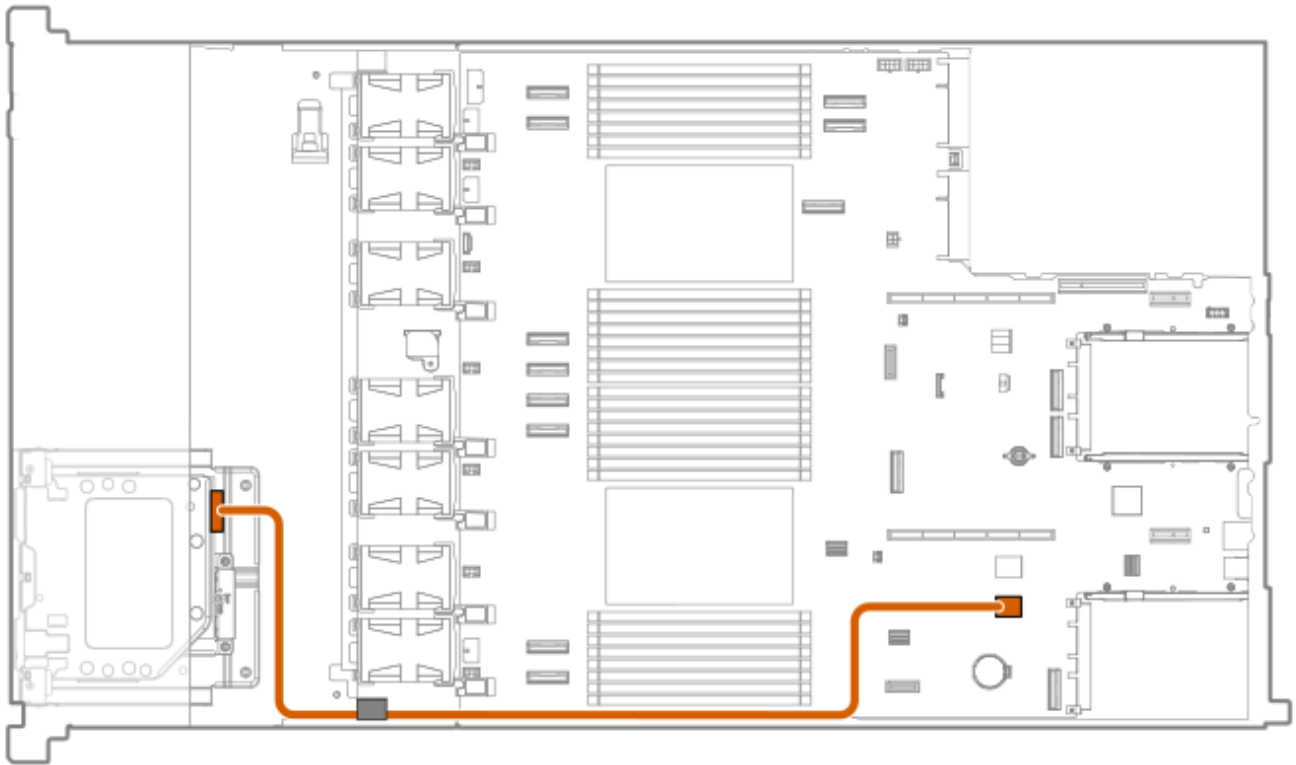

Cable part number	Color	From	To
P73776-002	Orange	Optical drive	Internal USB 3.2 Gen1 port

Front DisplayPort / USB cabling

4 LFF drive configuration: DisplayPort / USB cabling

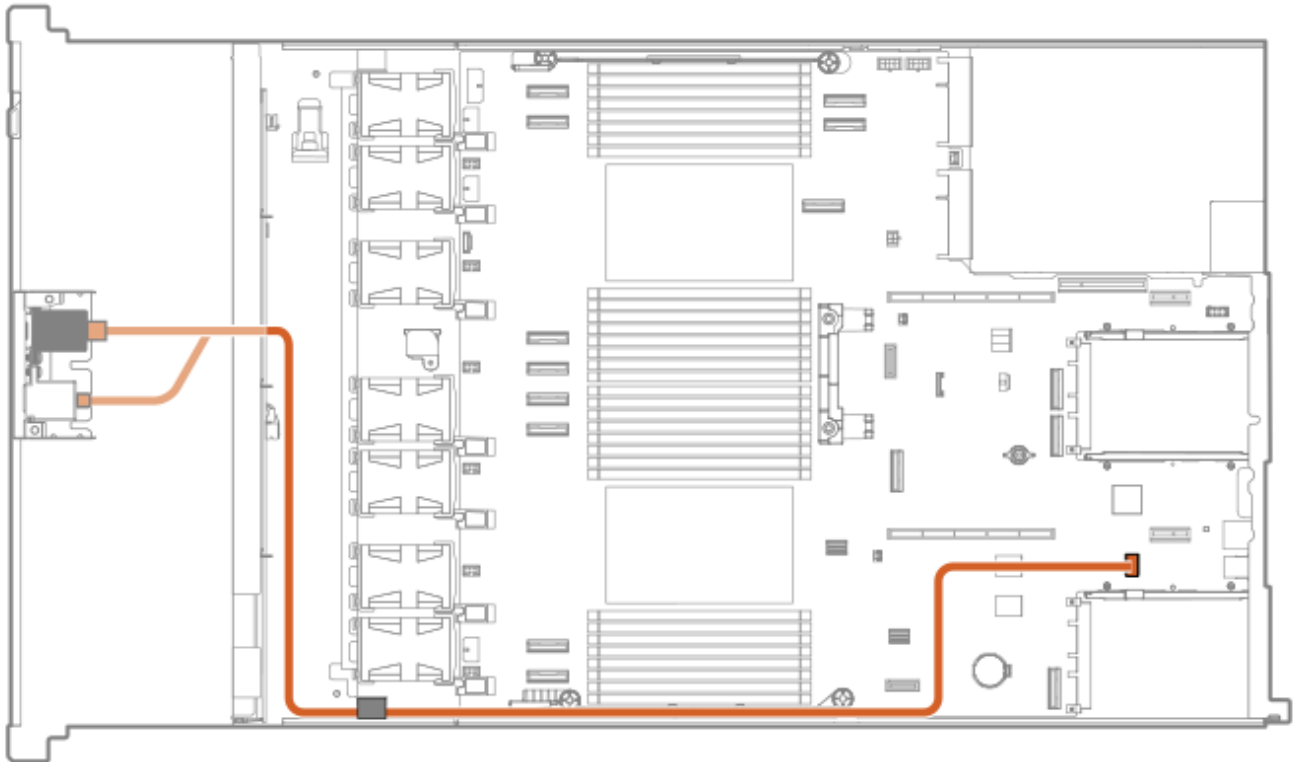

Cable part number	Color	From	To
P73948-001	Orange	4 LFF front display/USB B	DisplayPort and USB 2.0 port

8 SFF drive configuration: DisplayPort / USB cabling

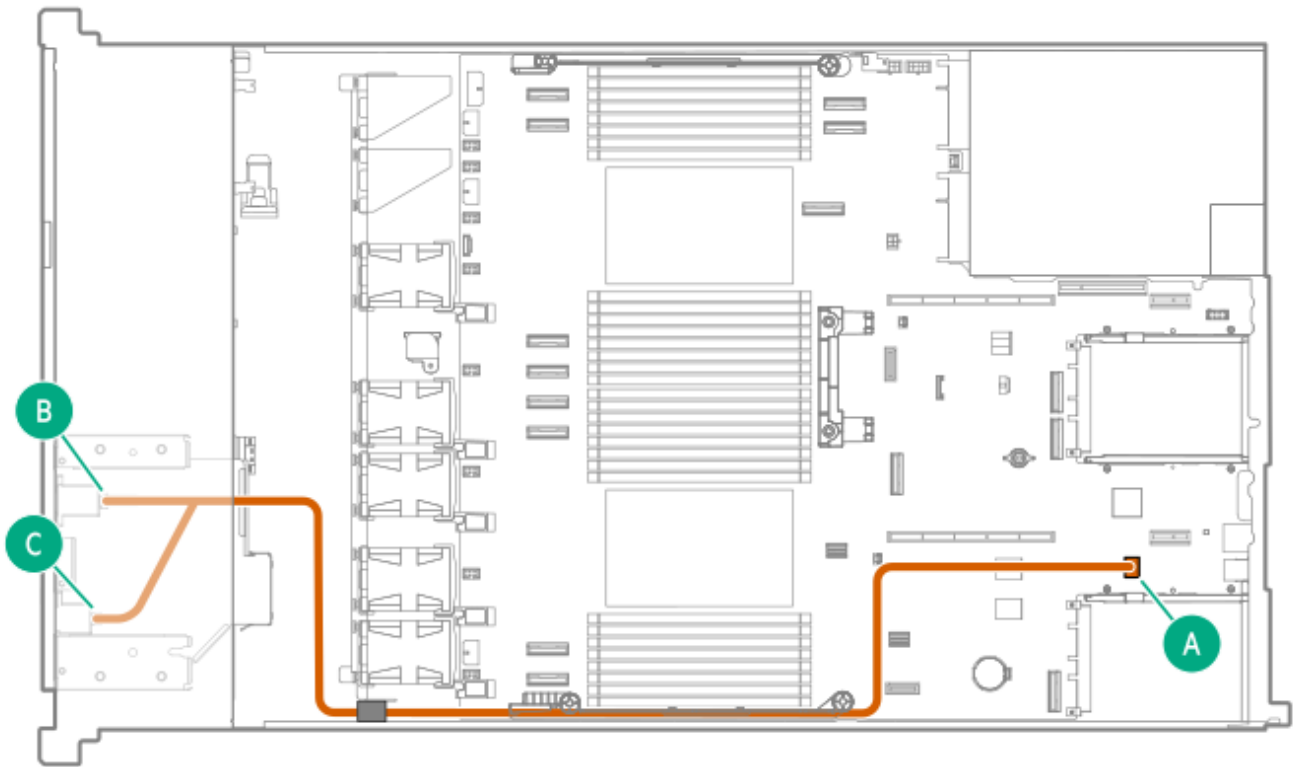

Cable part number	Color	From	To
P73948-001	Orange	8 SFF display/USB/OD D	DisplayPort and USB 2.0 port

Mixed drive type configuration: DisplayPort / USB cabling

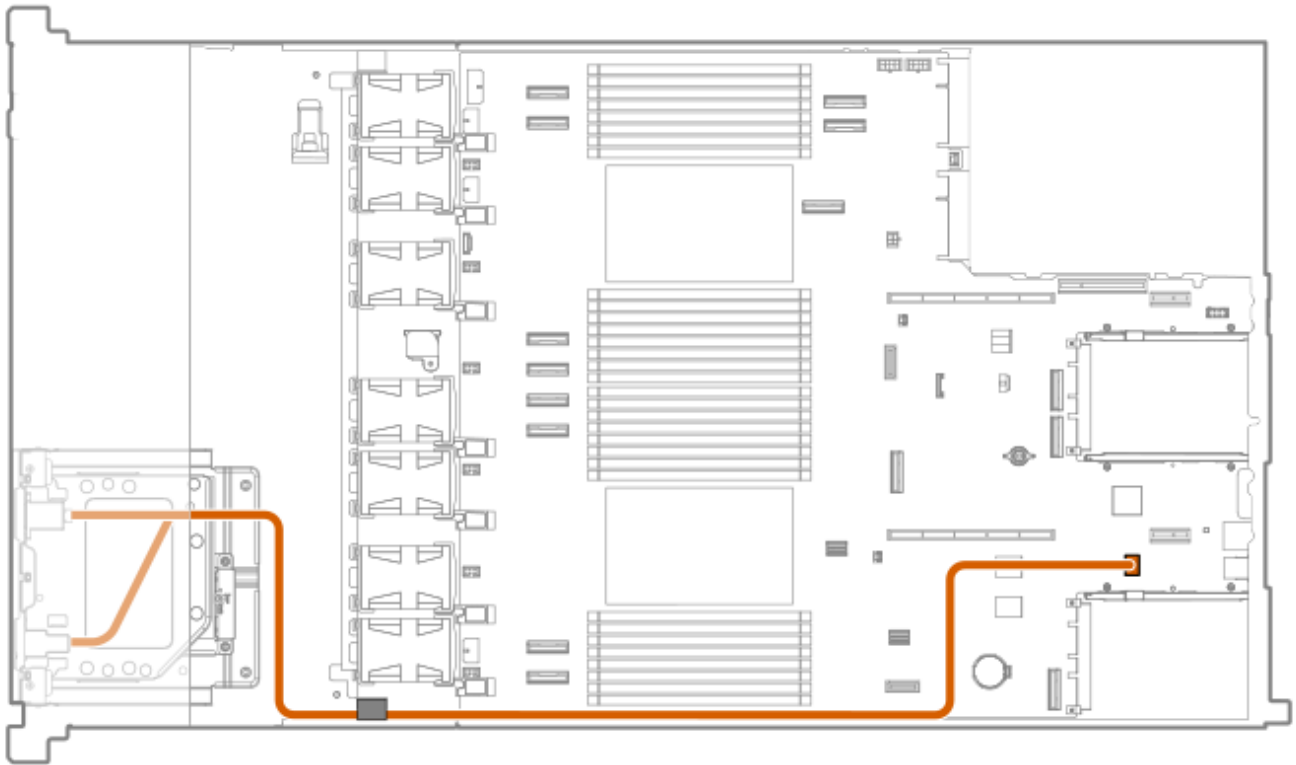

Cable part number	Color	From	To
P73948-001	Orange	Mixed drive type display/USB/ODD	DisplayPort and USB 2.0 port

Internal boot device cabling

- 4 LFF server

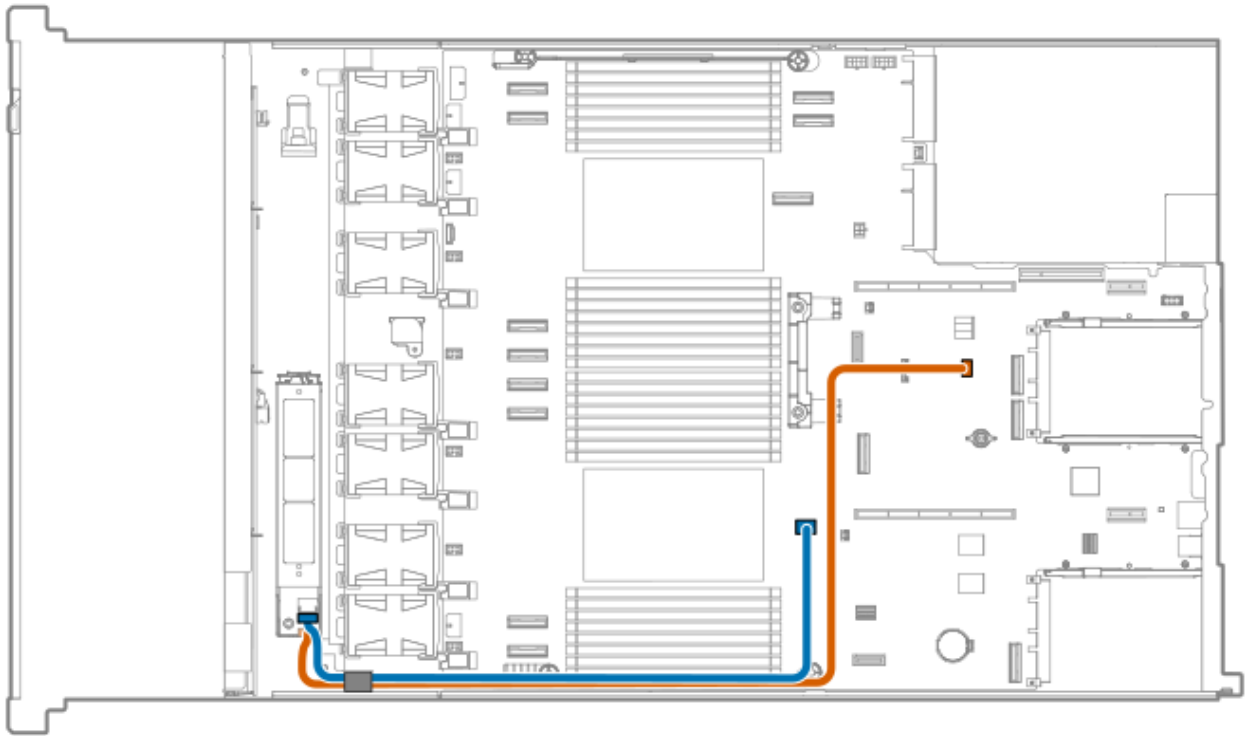

Cable part number	Color	From	To
P48956-001	Orange	Boot device power connector	NS204i-u power connector
P74839-001	Blue	Boot device signal connector	NS204i-u signal connector

- 8 SFF server

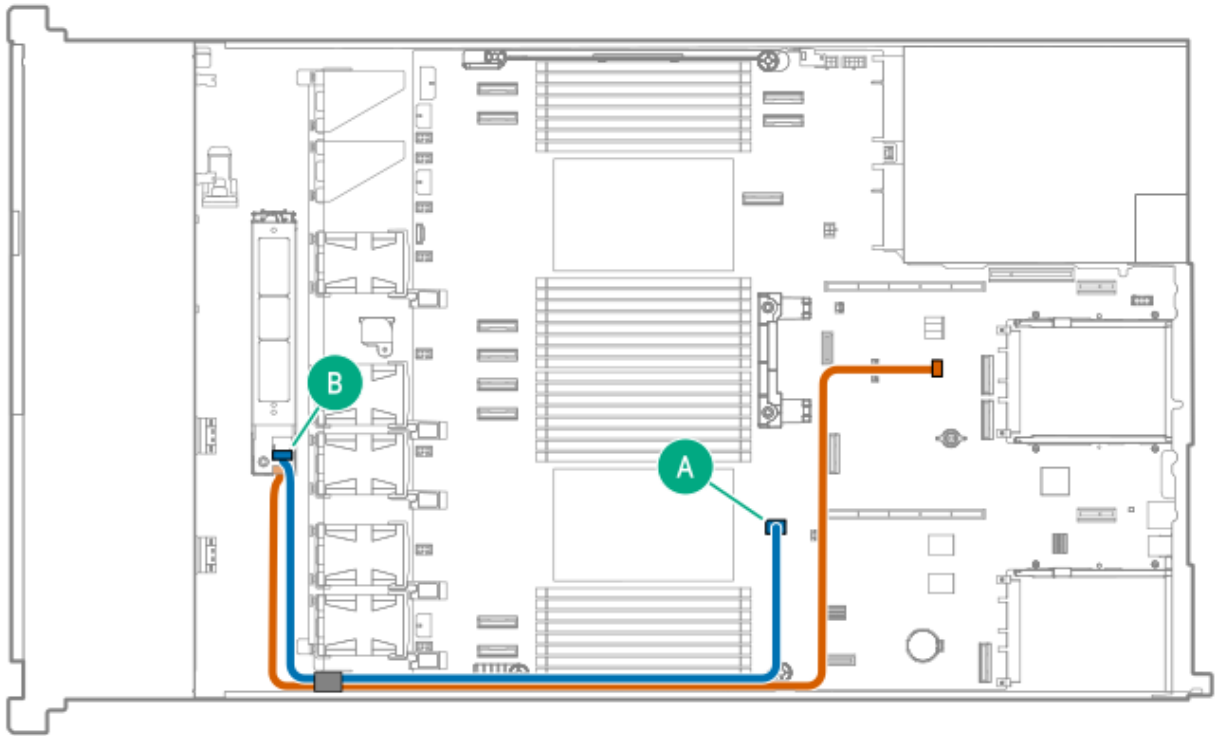

Cable part number	Color	From	To
P48956-001	Orange	Boot device power connector	NS204i-u power connector
P74839-001	Blue	Boot device signal connector	NS204i-u signal connector

- 10 SFF / 20 E3.S server

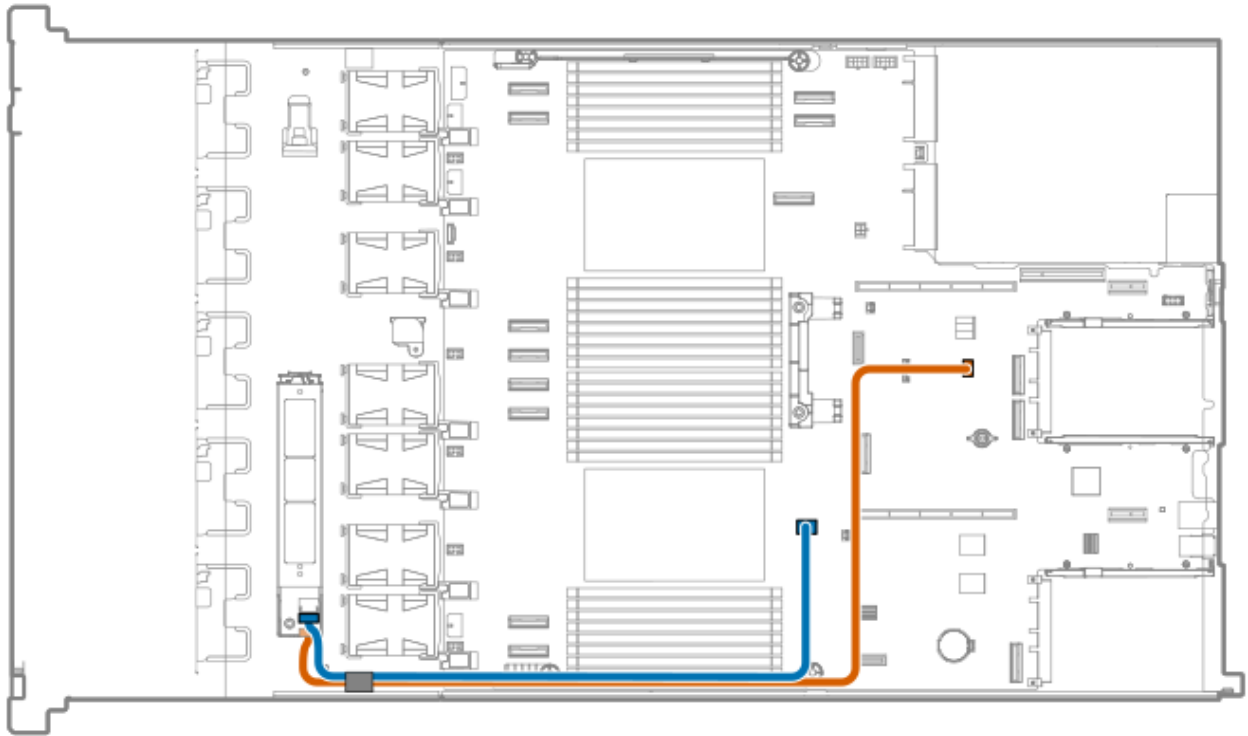

Cable part number	Color	From	To
P48956-001	Orange	Boot device power connector	NS204i-u power connector
P74839-001	Blue	Boot device signal connector	NS204i-u signal connector

Front panel boot device in the 10 SFF / 20 E3.S server or mixed drive type configuration

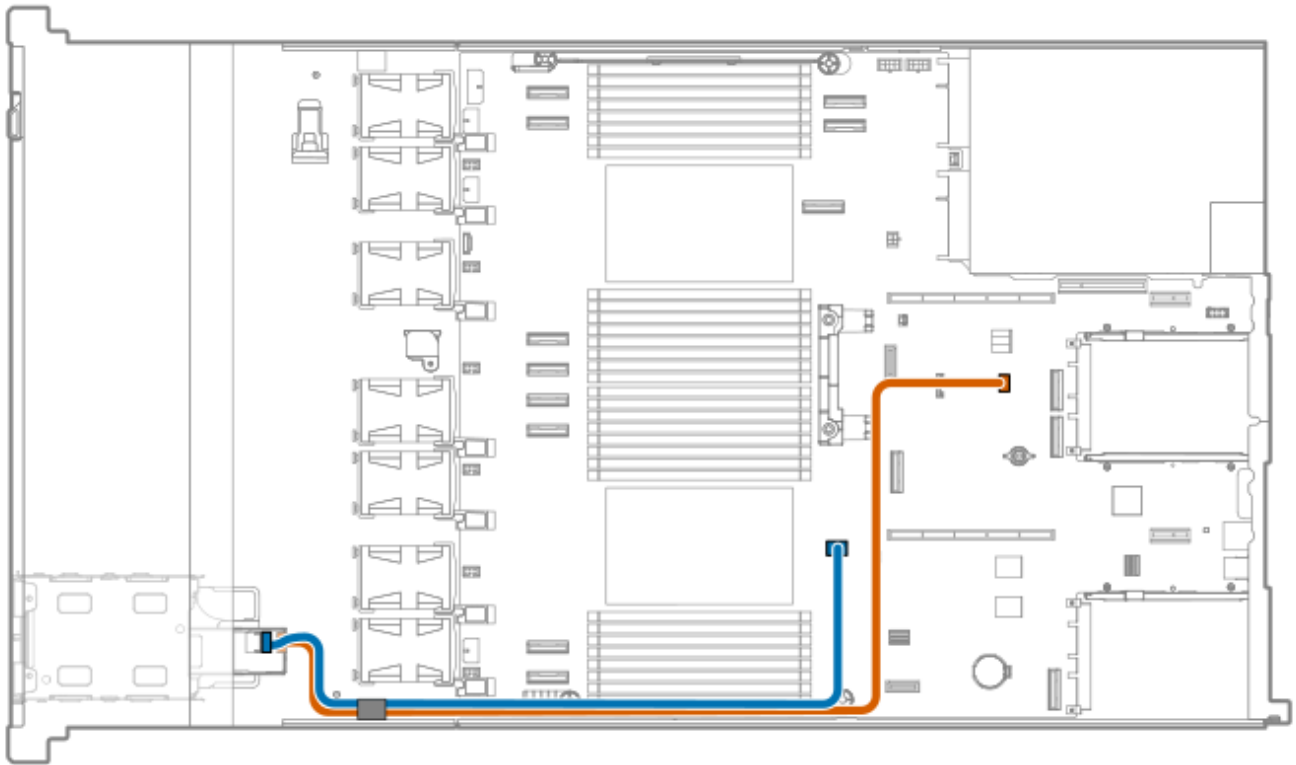

Cable part number	Color	From	To
P48956-001	Orange	Boot device power connector	NS204i-u power connector
P74839-001	Blue	Boot device signal connector	NS204i-u signal connector

Riser cage boot device cabling

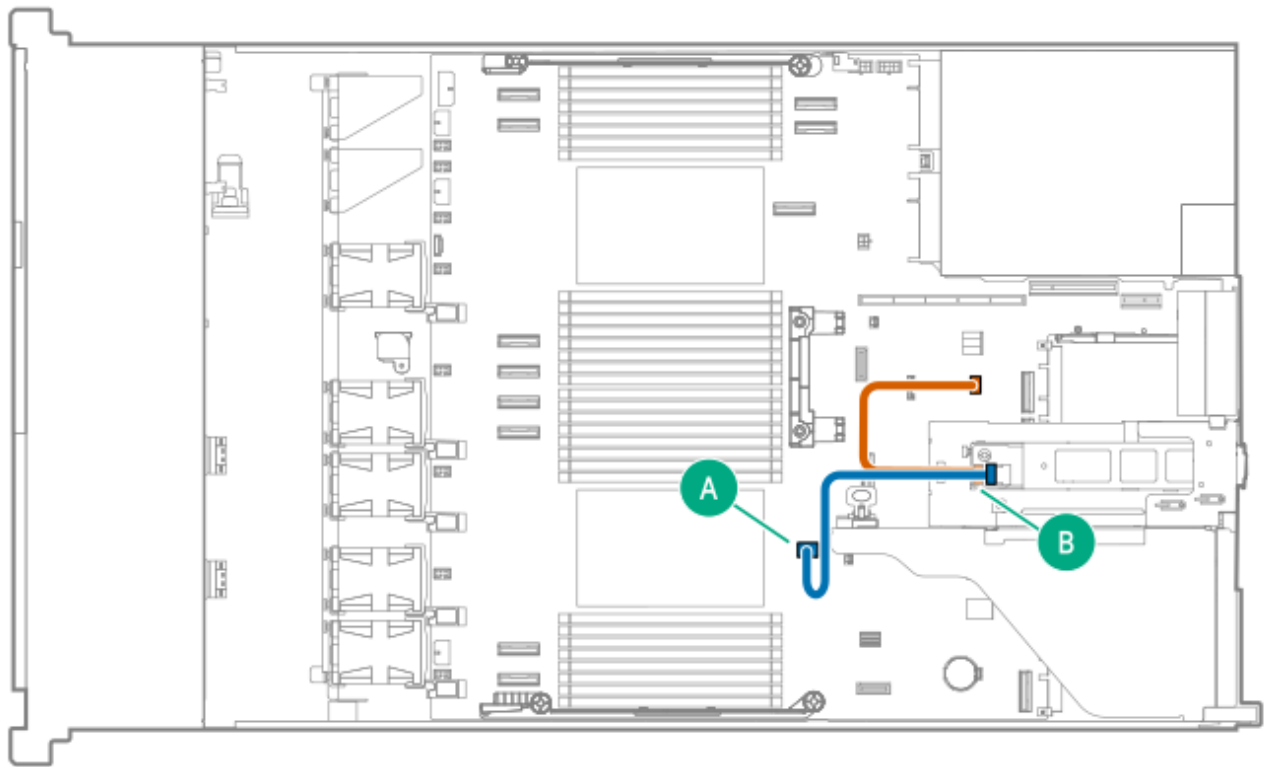

Cable part number	Color	From	To
P54088-001	Orange	Boot device power connector	NS204i-u power connector
P71913-001	Blue	Boot device signal connector	NS204i-u signal connector

Front OCP NIC cabling

Primary front OCP NIC cabling



Cable part number	Color	From	To
P71942-001	Gold	Front OCP NIC cable	MCIO port 1
	Blue		MCIO port 2
	Orange		OCP NIC interposer: J35
	Pink		PHY board: J1 (to-INT)
P73927-001	Green	PHY board: J2 (to-OCP)	OCP NIC interposer: J4 (to-PHY)

Secondary front OCP NIC cabling



Cable part number	Color	From	To
P71942-001	Gold	Front OCP NIC cable	MCIO port 7
	Blue		MCIO port 8
	Orange		OCP NIC interposer: J35
	Light gray		—

OCP bandwidth enablement cabling

Slot 14 OCP A x16 enablement

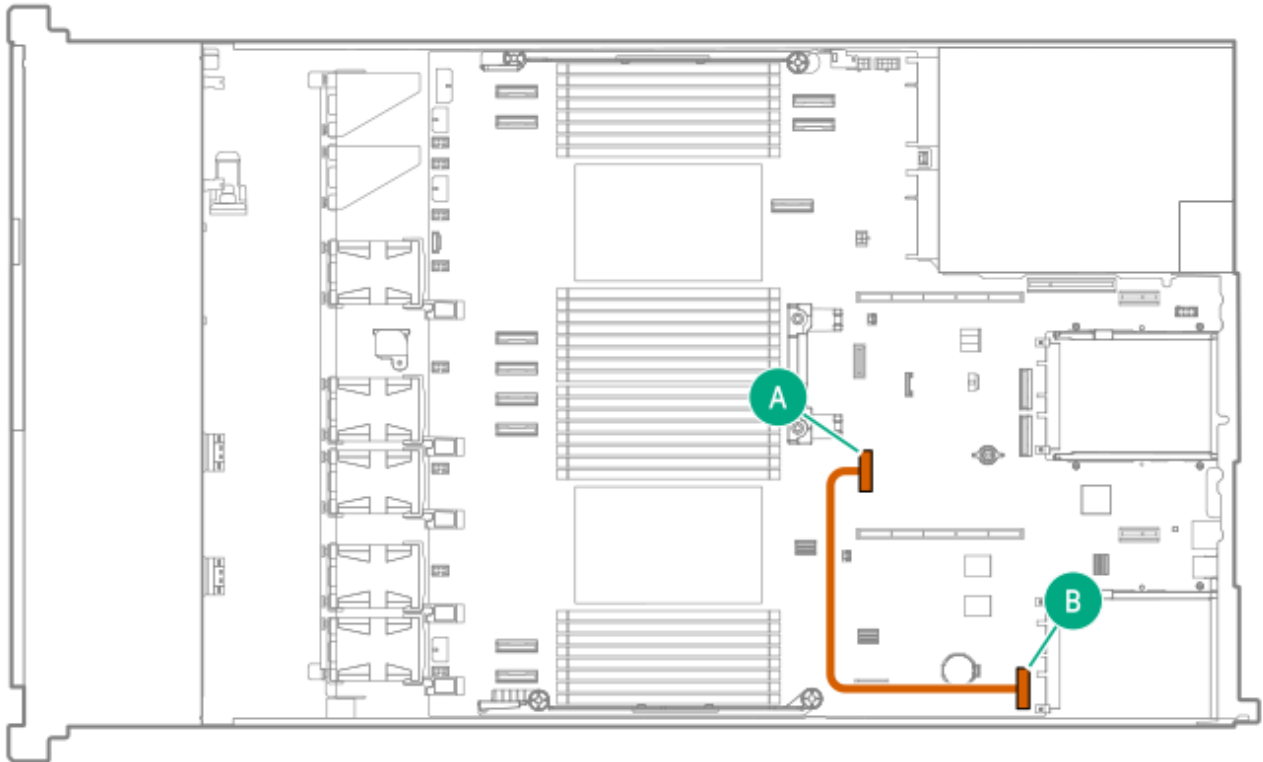

Cable part number	Color	From	To
P74890-001	Orange	OCP A internal port 1	MCIO port 12

CPU1 to Slot 15 OCP B x8 enablement



Cable part number	Color	From	To
P74889-001	Orange	OCP B internal port 1	MCIO port 12

CPU2 to Slot 15 OCP B x8 enablement

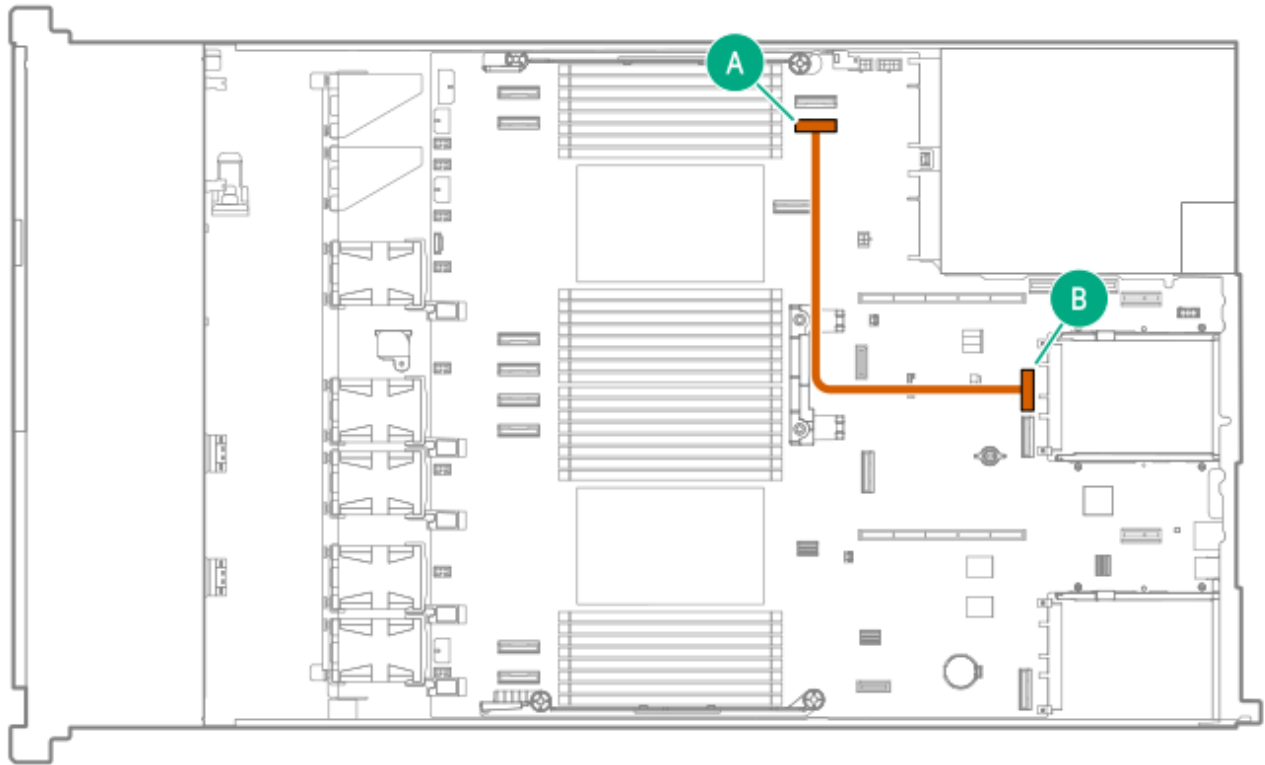

Cable part number	Color	From	To
P74891-001	Orange	OCP B internal port 1	MCIO port 10

CPU2 to Slot 15 OCP B x16 enablement

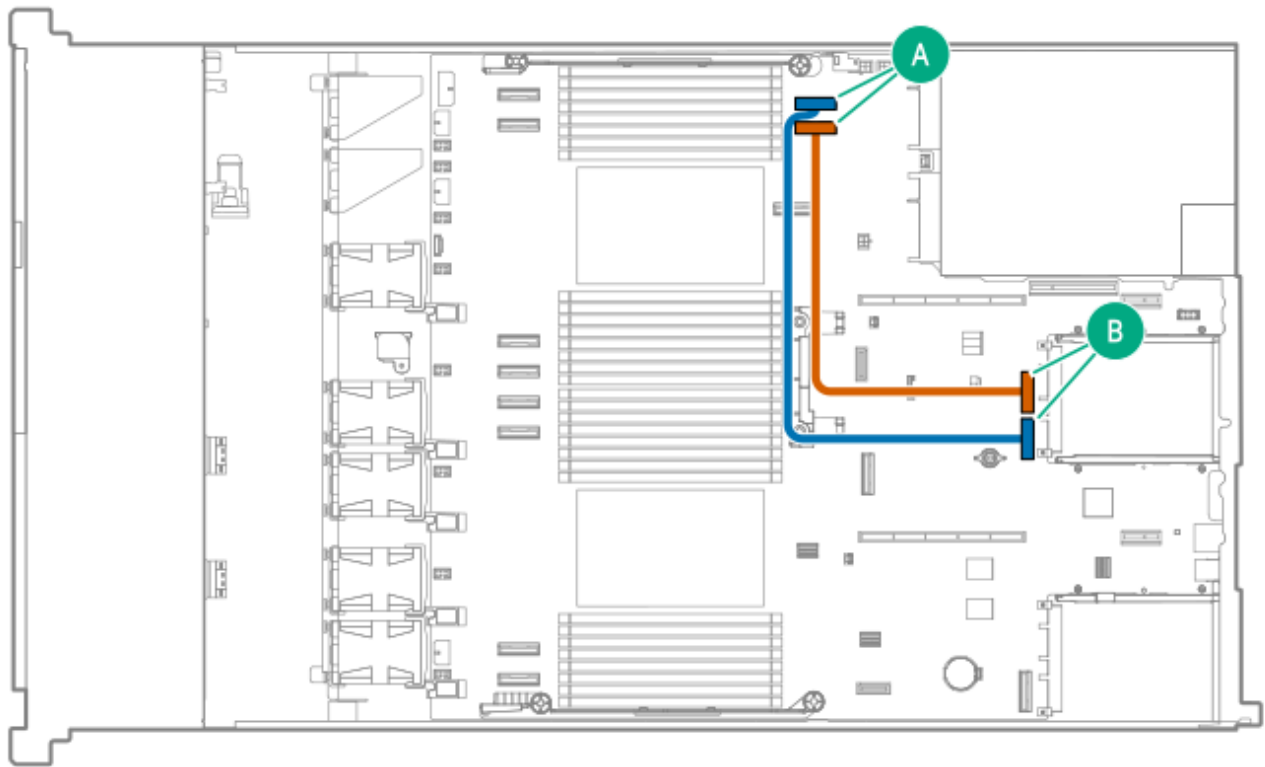

Cable part number	Color	From	To
P74891-001	Orange	OCP B internal port 1	MCI0 port 10
P74891-001	Blue	OCP B internal port 2	MCI0 port 9

Serial port cabling

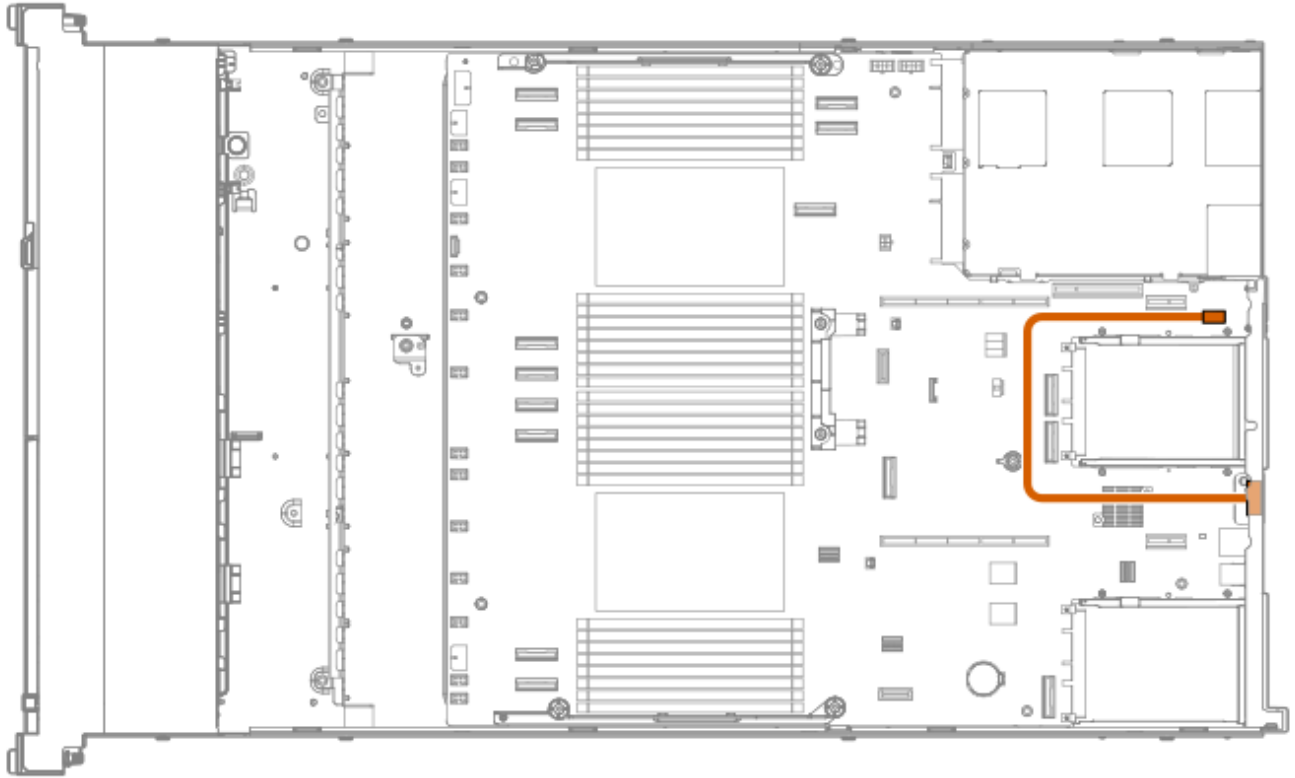

Cable part number	Color	From	To
P45623-001	Orange	Serial port	Serial port cable connector

Chassis intrusion detection switch cabling



Cable part number	Color	From	To
P47751-001	Orange	Intrusion detection switch	Chassis intrusion detection switch connector

Front I/O cabling

Front I/O cables are preinstalled in the server.



Cable part number	Color	From	To
P71909-002	Orange	Right chassis ear	Front I/O connector

System Insight Display cabling

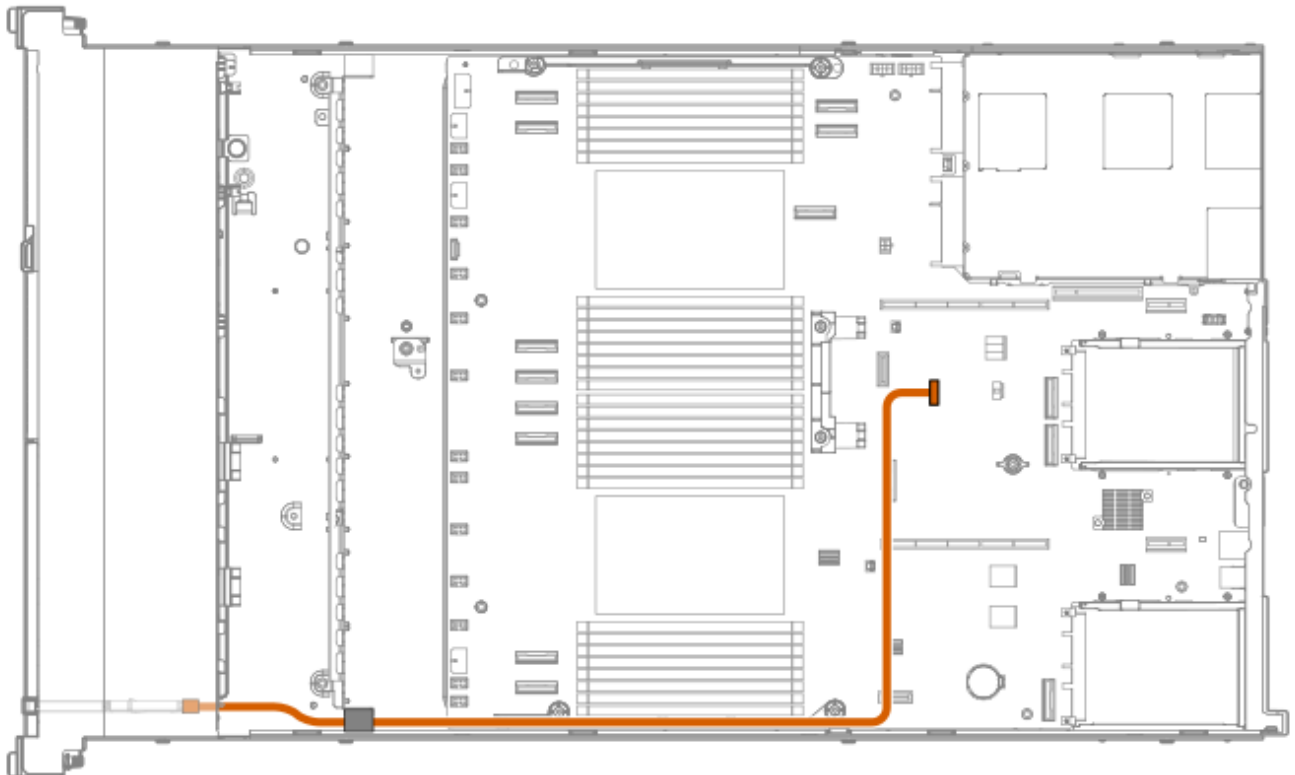

Cable part number	Color	From	To
P48971-001	Orange	System Insight Display module	SID connector

Liquid cooling module cabling

Closed-loop liquid cooling module cabling



Option kit	Color	From	To
Closed-loop liquid cooling module	Orange	Liquid cooling heatsink	Liquid cooling module connector

Direct liquid cooling module cabling

The cable routing is identical for both available direct liquid cooling solutions (P74208-B21, P79273-B21).



Option kit	Color	From	To
DLC cold plate module *	Orange	Cold plate module	Liquid cooling module connector

* The DLC cold plate modules are factory-installed options.

Configuration resources

Use the following resources to find documentation for configuring and managing your server.

- Some utilities might not apply to your server. For information about server compatibility with the products listed in this chapter, see the product QuickSpecs (<https://www.hpe.com/info/quickspecs>).

- Products ordered from HPE Factory Express might have already been configured with some or all the configurations in this chapter. To determine if any additional setup is required, see your HPE Factory Express order.
- For one-stop access to version-specific software and firmware documentation, including the latest product release notes, see this quick links page:
<https://www.hpe.com/support/hpeproductdocs-quicklinks>

Subtopics

- [Updating firmware or system ROM](#)
- [Configuring the server](#)
- [Configuring storage controllers](#)
- [Deploying an OS](#)
- [Configuring security](#)
- [Server management](#)
- [Managing Linux-based high performance compute clusters](#)

Updating firmware or system ROM

To	Use
Download service packs	<ul style="list-style-type: none"> • Service Pack for HPE ProLiant https://www.hpe.com/servers/spp/download • Get an overview of SPP and its ecosystem https://www.hpe.com/support/SPP-overview-vids-en
Deploy service packs to a single server	Smart Update Manager https://www.hpe.com/support/hpesmartupdatemanager-quicklinks
Deploy service packs to multiple servers	HPE OneView https://www.hpe.com/support/hpeoneview-quicklinks
Updating iLO or system firmware in a single server	iLO user guide

To	Use
	<u>https://www.hpe.com/support/hpeilodocs-quicklinks</u>
<ul style="list-style-type: none"> • Enable policy-based management of server or server group firmware for distributed server infrastructure • Monitor server compliance with a configured firmware baseline • Receive automatic iLO firmware updates • Receive baseline update alerts 	<p>HPE Compute Ops Management</p> <p><u>https://www.hpe.com/support/hpe-gl-com-quicklinks</u></p>

Configuring the server

To configure	Use
Single server (GUI)	<ul style="list-style-type: none"> • Intelligent Provisioning <u>https://www.hpe.com/support/hpeintelligentprovisioning-quicklinks</u> • iLO remote console or web interface <u>https://www.hpe.com/support/hpeilodocs-quicklinks</u> • UEFI System Utilities <u>https://www.hpe.com/support/hpeuefisystemutilities-quicklinks</u> • HPE Compute Ops Management <u>https://www.hpe.com/support/hpe-gl-com-quicklinks</u>
Single server (scripting)	<ul style="list-style-type: none"> • RESTful Interface Tool

To configure

Use

<https://www.hpe.com/support/restfulinterface/docs>

- Python iLO Redfish Library (python-ilo-rest-library)

<https://github.com/HewlettPackard/python-ilo-rest-library>

- Scripting Tools for Windows Powershell

<https://www.hpe.com/info/powershell/docs>

- iLO RESTful API

<https://servermanagementportal.ext.hpe.com/>

- HPE Compute Ops Management API

<https://developer.greenlake.hpe.com/>

Multiple servers (either UI or scripting)

- HPE OneView ¹_—

<https://www.hpe.com/support/hpeoneview-quicklinks>

- HPE Compute Ops Management

<https://www.hpe.com/support/hpe-gl-com-quicklinks>

- **Server settings:** Define server-specific parameters such as firmware baselines, and then apply them to server groups.
- **Server groups:** Organize servers into custom-defined sets with associated server settings, and then apply group-specific policies to create a consistent configuration across the servers in the group.

¹_— For servers running HPE OneView, do not use another tool, such as iLO, to delete or change certain settings. For more information about using HPE OneView and iLO to manage the same server, see the iLO user guide at <https://www.hpe.com/support/hpeilodocs-quicklinks>.

Configuring storage controllers

Controller type	Documentation
HPE MR controller user guides	<ul style="list-style-type: none"><li data-bbox="833 352 1464 787">• HPE MR Gen11 Controller User Guide https://hpe.com/support/MR-Gen11-UG<ul style="list-style-type: none"><li data-bbox="889 485 1464 615">◦ MR Gen11 controller configuration: https://www.hpe.com/support/MR-Gen11-configuration<li data-bbox="889 653 1464 783">◦ MR Gen11 controller RAID creation: https://www.hpe.com/support/MR-Gen11-RAID-creation<li data-bbox="833 825 1464 1304">• HPE MR932i-p PCIe SPDM PI Storage Controller User Guide https://hpe.com/support/MR932i-UG<ul style="list-style-type: none"><li data-bbox="889 999 1464 1129">◦ MR932i-p controller configuration: www.hpe.com/support/MR932i-configuration<li data-bbox="889 1167 1464 1297">◦ MR932i-p controller RAID creation: www.hpe.com/support/MR932i-RAID-creation
HPE MR controller configuration guides	<ul style="list-style-type: none"><li data-bbox="833 1381 1390 1476">• HPE MR Storage Administrator User Guide https://www.hpe.com/support/MRSA<li data-bbox="833 1514 1365 1608">• HPE StorCLI User Guide https://www.hpe.com/support/StorCLI<li data-bbox="833 1646 1382 1728">• HPE StorCLI2 User Guide https://www.hpe.com/support/StorCLI2
Intel VROC for HPE Gen12	<ul style="list-style-type: none"><li data-bbox="833 1806 1425 1894">• Intel Virtual RAID on CPU for HPE User Guide https://www.hpe.com/support/VROC-UG

Controller type

Documentation

- Intel VROC NVMe RAID quick installation:

<https://www.hpe.com/support/VROC-NVMe-RAID-installation>

OS-specific configuration guides:

- Intel Virtual RAID on CPU (Intel VROC) for Windows User Guide

https://docs.graidtech.com/vroc/User_Guides/000094004_Intel_Virtual_RAID_on_CPU_Intel_VROC_User_Guide_for_Windows/

- Intel Virtual RAID on CPU (Intel VROC) for Linux User Guide

https://docs.graidtech.com/vroc/User_Guides/000094694_Intel_Virtual_RAID_on_CPU_Intel_VROC_User_Guide_for_Linux/

- Intel Volume Management Device Driver for VMware ESXi User Guide

https://docs.graidtech.com/vroc/User_Guides/000094787_Intel_Virtual_RAID_on_CPU_Intel_VROC_User_Guide_for_VMware_ESXi/

Deploying an OS

For a list of supported operating systems, see the HPE Servers Support & Certification Matrices:

<https://www.hpe.com/support/Servers-Certification-Matrices>

To

See

Deploy an OS using HPE Compute Ops Management HPE Compute Ops Management User Guide

<https://www.hpe.com/support/hpe-gl-com-quicklinks>

Deploy an OS using Intelligent Provisioning

Intelligent Provisioning user guide

To	See
	https://www.hpe.com/support/hpeintelligentprovisioning-quicklinks
Deploy an OS using iLO virtual media	iLO user guide https://www.hpe.com/support/hpeilodocs-quicklinks
Configure the server to boot from a PXE server	UEFI System Utilities User Guide for HPE Compute servers https://www.hpe.com/support/UEFIGen12-UG-en
Configure the server to boot from a SAN	HPE Boot from SAN Configuration Guide https://www.hpe.com/info/boot-from-san-configuration-guide

Configuring security

To	See
Implement server security best practices.	<ul style="list-style-type: none"> HPE Compute Security Reference Guide https://www.hpe.com/info/server-security-reference-en HPE iLO 7 Security Technology Brief https://www.hpe.com/support/ilo7-security-en
Configure and use the Server Configuration Lock feature on HPE Trusted Supply Chain servers and other servers that have the Server Configuration Lock feature enabled.	Server Configuration Lock User Guide for HPE ProLiant servers and HPE Synergy https://www.hpe.com/info/server-config-lock-UG-en

Server management

To monitor	See
Single server	HPE iLO https://www.hpe.com/support/hpeilodocs-quicklinks
Multiple servers	HPE OneView https://www.hpe.com/support/hpeoneview-quicklinks
Single or multiple servers	HPE Compute Ops Management https://www.hpe.com/support/hpe-gl-com-quicklinks

Managing Linux-based high performance compute clusters

To	Use
Provision, manage, and monitor clusters.	HPE Performance Cluster Manager https://www.hpe.com/support/hpcm_manuals
Optimize your applications.	HPE Performance Analysis Tools https://www.hpe.com/info/perftools
Optimize software library for low latency and high bandwidth, both on-node and off-node, for point-to-point and collective communications.	HPE Cray Programming Environment User Guide https://www.hpe.com/info/cray-pe-user-guides

Safety, warranty, and regulatory information

Subtopics

Regulatory information

Warranty information

Regulatory information

To view the regulatory information for your product, view the Safety and Compliance Information for Server, Storage, Power, Networking, and Rack Products, available at the Hewlett Packard Enterprise Support Center:

<https://www.hpe.com/support/Safety-Compliance-EnterpriseProducts>

Additional regulatory information

Hewlett Packard Enterprise is committed to providing our customers with information about the chemical substances in our products as needed to comply with legal requirements such as REACH (Regulation EC No 1907/2006 of the European Parliament and the Council). A chemical information report for this product can be found at:

<https://www.hpe.com/info/reach>

For Hewlett Packard Enterprise product environmental and safety information and compliance data, including RoHS and REACH, see:

<https://www.hpe.com/info/ecodata>

For Hewlett Packard Enterprise environmental information, including company programs, product recycling, and energy efficiency, see:

<https://www.hpe.com/info/environment>

Subtopics

[Notices for Eurasian Economic Union](#)

[Turkey RoHS material content declaration](#)

[Ukraine RoHS material content declaration](#)

Notices for Eurasian Economic Union



Manufacturer and Local Representative Information

Manufacturer information:

Hewlett Packard Enterprise Company, 1701 E Mossy Oaks Road, Spring, TX 77389 U.S.

Local representative information Russian:

- **Russia**

ООО "Хьюлетт Паккард Энтерпрайз", Российская Федерация, 125171, г. Москва, Ленинградское шоссе, 16А, стр.3, Телефон: +7 499 403 4248 Факс: +7 499 403 4677

- **Kazakhstan**

ТОО «Хьюлетт-Паккард (К)», Республика Казахстан, 050040, г. Алматы, Бостандыкский район, проспект Аль-Фараби, 77/7, Телефон/факс: + 7 727 355 35 50

Local representative information Kazakh:

- **Russia**

ЖШС "Хьюлетт Паккард Энтерпрайз", Ресей Федерациясы, 125171, Мәскеу, Ленинград тас жолы, 16А блок 3, Телефон: +7 499 403 4248 Факс: +7 499 403 4677

- **Kazakhstan**

ЖШС «Хьюлетт-Паккард (К)», Қазақстан Республикасы, 050040, Алматы к., Бостандык ауданы, Әл-Фараби даңғылы, 77/7, Телефон/факс: +7 727 355 35 50

Manufacturing date:

The manufacturing date is defined by the serial number.

CCSYWWZZZZ (product serial number format)

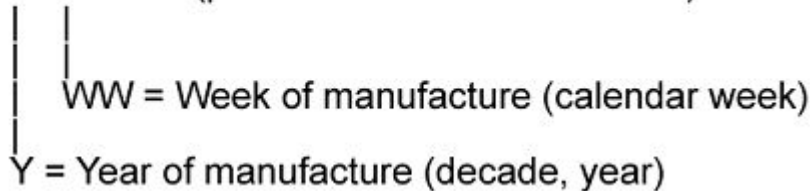

If you need help identifying the manufacturing date, contact tre@hpe.com.

Turkey RoHS material content declaration

Türkiye Cumhuriyeti: AEEE Yönetmeliğine Uygundur

Ukraine RoHS material content declaration

Обладнання відповідає вимогам Технічного регламенту щодо обмеження використання деяких небезпечних речовин в електричному та електронному обладнанні, затвердженого постановою Кабінету Міністрів України від 3 грудня 2008 № 1057

Warranty information

To view the warranty information for your product, see the [warranty check tool](#).

Specifications

Provides environmental, mechanical, and power supply specifications for the server.

Subtopics

[Environmental specifications](#)

[Server and rackmounting specifications](#)

[Power supply specifications](#)

Environmental specifications

Specifications	Value
Temperature range	—
Operating	10°C to 35°C (50°F to 95°F)
Nonoperating	Air-cooled systems: -30°C to 60°C (-22°F to 140°F) Liquid-cooled systems (DLC, CLLC): -10°C to 60°C (14°F to 140°F) CAUTION: To prevent freezing the coolant and damaging the liquid cooling module, do not keep the liquid-cooled systems below -10°C (14°F).

Specifications	Value
Relative humidity (noncondensing)	—
Operating	8% to 90% 28°C (82.4°F) maximum wet bulb temperature, noncondensing
Nonoperating	5% to 95% 38.7°C (101.7°F) maximum wet bulb temperature, noncondensing
Altitude	—
Operating	3050 m (10,000 ft) This value may be limited by the type and number of options installed. Maximum allowable altitude change rate is 457 m/min (1,500 ft/min).
Nonoperating	9144 m (30,000 ft) Maximum allowable altitude change rate is 457 m/min (1,500 ft/min).

Standard operating support

10° to 35°C (50° to 95°F) at sea level with an altitude derating of 1.0°C per every 305 m (1.8°F per every 1,000 ft) above sea level to a maximum of 3,050 m (10,000 ft), no direct sustained sunlight. Maximum rate of change is 20°C/hr (36°F/hr). The upper limit and rate of change might be limited by the type and number of options installed.

System performance under standard operating support might be reduced if operating above 30°C (86°F) or with a faulty fan installed.

Extended ambient operating support

For approved hardware configurations, the supported system inlet range is extended to be:

- 5° to 10°C (41° to 50°F) and 35° to 40°C (95° to 104°F) at sea level with an altitude derating of 1.0°C per every 175 m (1.8°F per every 574 ft) above 900 m (2,953 ft) to a maximum of 3050 m (10,000 ft).
- 40°C to 45°C (104°F to 113°F) at sea level with an altitude derating of 1.0°C per every 125 m (1.8°F per every 410 ft) above 900 m (2,953 ft) to a maximum of 3,050 m (10,000 ft).

The approved hardware configurations for this system are listed in the Extended Ambient Temperature Guidelines for Gen12 Servers:

<https://www.hpe.com/support/ASHRAEGen12>

Server and rackmounting specifications

Server dimensions



Item	Description	Dimension
1	Front bezel to rearmost edge of chassis ear	3.93 cm (1.55 in)
2	Rearmost edge of chassis ear to PSU	8 + 2 SFF: 78.28 cm (30.82 in) 4 LFF: 80.27 cm (31.61 in) 10 SFF / 20 EDSFF: 80.27 cm (31.61 in)
3	Rearmost edge of chassis ear to server rear I/O	8 + 2 SFF: 75.31 cm (29.65 in) 4 LFF: 77.30 cm (30.43 in) 10 SFF / 20 EDSFF: 77.30 cm (30.43 in)
4	Width	Chassis 43.46 cm (17.11 in)
5	Width	Ear-to-ear 48.26 cm (18.99 in)
6	Height	4.29 cm (1.69 in)

Rackmounting dimensions



Item	Description	Dimension
1	Front EIA mounting post to frontmost server feature	4.98 cm (1.96 in)
2	Front EIA mounting post to server rear I/O	8 SFF: 73.74 cm (29.03 in) 4 LFF or 10 SFF / 20 EDSFF: 75.73 cm (29.83 in)
3	Server rear I/O to rearmost CMA feature	16.85 cm (6.63 in)
4	Rail mount range (min to max) ¹	60.96 cm – 91.81 cm (24.00 in – 36.15 in) ²
5	Depth of front rail mount	1.57 cm (0.62 in)

- 1 The range between the front and rear posts of the rack
- 2 The minimum overall length of the rail kit is:
 - 8 SFF: 78.76 cm (31.00 in)
 - 4 LFF or 10 SFF / 20 EDSFF: 80.87 cm (31.84 in)

Server weight

Weight, approximate values	Value
Weight, 8 + 2 SFF minimum (One drive, one processor, one heatsink, one power supply, one Smart Array controller, and five fans installed)	14.87 kg (32.71 lb)
Weight, 8 + 2 SFF maximum (Ten drives, two processors, two heatsinks, two power supplies, one Smart Array controller, and seven fans installed)	19.94 kg (43.96 lb)
Weight, 4 LFF minimum (One drive, one processor, one heatsink, one power supply, one Smart Array controller, and five fans installed)	15.25 kg (33.55 lb)
Weight, 4 LFF maximum (Four drives, two processors, two heatsinks, two power supplies, one Smart Array controller, and seven fans installed)	20.92 kg (46.02 lb)
Weight, 10 SFF / 20 EDSFF minimum (One drive, two processors, two heatsinks, one power supply, one Smart Array controller, and seven fans installed)	14.92 kg (32.82 lb)
Weight, 10 SFF / 20 EDSFF maximum (Twenty drives, two processors, two heatsinks, two power supplies, one Smart Array controller, and seven fans installed)	21.38 kg (47.04 lb)

Power supply specifications

Depending on the installed options and the regional location where the server was purchased, the server can be configured with one of the following power supplies. For detailed power supply specifications, see the QuickSpecs on the [Hewlett Packard Enterprise website](#).

Subtopics

[HPE 800 W Flex Slot Platinum Hot-plug Low Halogen Power Supply](#)

[HPE 1000 W Flex Slot Titanium Hot-plug Power Supply](#)

[HPE 1600 W Flex Slot Platinum Hot-plug Low Halogen Power Supply](#)

[HPE 1600 W Flex Slot -48 VDC Hot-plug Power Supply](#)

[HPE 1800-2200 W Flex Slot Titanium Power Supply](#)

HPE 800 W Flex Slot Platinum Hot-plug Low Halogen Power Supply

Specification	Value
Input requirements	—
Rated input voltage	100 VAC to 127 VAC 200 VAC to 240 VAC 240 VDC for China only
Rated input frequency	50 Hz to 60 Hz Not applicable to 240 VDC
Rated input current	9.4 A at 100 VAC 4.5 A at 200 VAC 3.8 A at 240 VDC for China only
Maximum rated input power	940 W at 100 VAC 900 W at 200 VAC 897 W at 240 VDC for China only
BTUs per hour	3067 at 100 VAC 2958 at 200 VAC 2949 at 240 VAC for China only

Specification	Value
Power supply output	—
Rated steady-state power	800 W at 100 VAC to 127 VAC input 800 W at 100 VAC to 240 VAC input 800 W at 240 VDC input for China only
Maximum peak power	800 W at 100 VAC to 127 VAC input 800 W at 100 VAC to 240 VAC input 800 W at 240 VDC input for China only

HPE 1000 W Flex Slot Titanium Hot-plug Power Supply

Specification	Value
Input requirements	—
Rated input voltage	100 VAC to 127 VAC 200 VAC to 240 VAC 240 VDC for China
Rated input frequency	50 Hz to 60 Hz
Rated input current	11.3 A at 100 VAC 6.1 A at 200 VAC
Maximum rated input power	1130 W at 100 VAC 1090 W at 200 VAC
BTUs per hour	3764 at 100 VAC 3629 at 200 VAC
Power supply output	—
Rated steady-state power	1000 W at 100 VAC to 127 VAC 1000 W at 200 VAC to 240 VAC input
Maximum peak power	1000 W at 100 VAC to 127 VAC 1000 W at 200 VAC to 240 VAC

HPE 1600 W Flex Slot Platinum Hot-plug Low Halogen Power Supply

Specification	Value
Input requirements	—
Rated input voltage	200 VAC to 240 VAC 240 VDC for China only
Rated input frequency	50 Hz to 60 Hz
Rated input current	8.7 A at 200 VAC 7.5 A at 230 VAC 7.2 A at 240 VDC
Maximum rated input power	1734 W at 200 VAC 1720 W at 240 VAC
BTUs per hour	5918 at 200 VAC 5891 at 230 VAC
Power supply output	—
Rated steady-state power	1600 W at 200 VAC to 240 VAC input 1600 W at 240 VDC input
Maximum peak power	1600 W for 1 ms (turbo mode) at 200 VAC to 240 VAC input

HPE 1600 W Flex Slot -48 VDC Hot-plug Power Supply

Specification	Value
Input requirements	—
Rated input voltage	-40 VDC to -72 VDC
Rated input frequency	DC

Specification	Value
Nominal input current	45 A DC at -40 VDC input 36.6 A DC at -48 VDC input 24.4 A DC at -72 VDC input
Maximum Rated Input Wattage Rating	1798 W at -40 VDC input 1758 W at -48 VDC input 1755 W at -72 VDC input
BTUs per hour	6026 at -40 VDC input 6000 at -48 VDC input 5989 at -72 VDC input
Power supply output	—
Rated steady-state power	1600 W at -40 VDC to -72 VDC
Maximum peak power	1600 W at -40 VDC to -72 VDC

HPE 1800-2200 W Flex Slot Titanium Power Supply

Specification	Value
Input requirements	—
Rated input voltage	200 VAC to 240 VAC 240 VDC for China only
Rated input frequency	50 Hz to 60 Hz
Rated input current	10 A at 200 VAC 10 A at 240 VAC 10 A at 240 VDC for China only
Maximum rated input power	1946 W at 200 VAC 2375 W at 240 VAC 2375 W at 240 VDC for China only
BTUs per hour	6497 at 200 VAC

Specification	Value
	7962 at 240 VAC
Power supply output	—
Rated steady-state power	1800 W at 200 VAC 2200 W at 240 VAC
Maximum peak power	2200 W for 1 ms (turbo mode) at 200 VAC to 240 VAC input

Support and other resources

- [Accessing Hewlett Packard Enterprise Support](#)
- [Accessing updates](#)
- [Remote support](#)
- [Warranty information](#)
- [Regulatory information](#)
- [Documentation feedback](#)

Subtopics

[**Accessing Hewlett Packard Enterprise Support**](#)

[**HPE product registration**](#)

[**Accessing updates**](#)

[**Remote support**](#)

[**Documentation feedback**](#)

Accessing Hewlett Packard Enterprise Support

- For live assistance, go to the Contact Hewlett Packard Enterprise Worldwide website:

[**https://www.hpe.com/info/assistance**](https://www.hpe.com/info/assistance)

- To access documentation and support services, go to the Hewlett Packard Enterprise Support Center website:

<https://www.hpe.com/support/hpesc>

Information to collect

- Technical support registration number (if applicable)
- Product name, model or version, and serial number
- Operating system name and version
- Firmware version
- Error messages
- Product-specific reports and logs
- Add-on products or components
- Third-party products or components

HPE product registration

To gain the full benefits of the Hewlett Packard Enterprise Support Center and your purchased support services, add your contracts and products to your account on the HPESC.

- When you add your contracts and products, you receive enhanced personalization, workspace alerts, insights through the dashboards, and easier management of your environment.
- You will also receive recommendations and tailored product knowledge to self-solve any issues, as well as streamlined case creation for faster time to resolution when you must create a case.

To learn how to add your contracts and products, see <https://www.hpe.com/info/add-products-contracts>.

Accessing updates

- Some software products provide a mechanism for accessing software updates through the product interface. Review your product documentation to identify the recommended software update method.
- To download product updates:

Hewlett Packard Enterprise Support Center

<https://www.hpe.com/support/hpesc>

My HPE Software Center

<https://www.hpe.com/software/hpesoftwarecenter>

- To subscribe to eNewsletters and alerts:

<https://www.hpe.com/support/e-updates>

- To view and update your entitlements, and to link your contracts and warranties with your profile, go to the Hewlett Packard Enterprise Support Center **More Information on Access to Support Materials** page:

<https://www.hpe.com/support/AccessToSupportMaterials>



IMPORTANT

Access to some updates might require product entitlement when accessed through the Hewlett Packard Enterprise Support Center. You must have an HPE Account set up with relevant entitlements.

Remote support

Remote support is available with supported devices as part of your warranty or contractual support agreement. It provides intelligent event diagnosis, and automatic, secure submission of hardware event notifications to Hewlett Packard Enterprise, which initiates a fast and accurate resolution based on the service level of your product. Hewlett Packard Enterprise strongly recommends that you register your device for remote support.

If your product includes additional remote support details, use search to locate that information.

HPE Get Connected

<https://www.hpe.com/services/getconnected>

HPE Tech Care Service

<https://www.hpe.com/services/techcare>

HPE Complete Care Service

<https://www.hpe.com/services/completecure>

Documentation feedback

Hewlett Packard Enterprise is committed to providing documentation that meets your needs. To help us improve the documentation, click the **Feedback** button on the page of an opened document on the Hewlett Packard Enterprise Support Center portal (<https://www.hpe.com/support/hpesc>). Use this feature to send any errors, suggestions, or comments. This process captures all document information.

Appendix I: Server coolant spill response

Subtopics

Eye and skin protection

Server coolant leak

Eye and skin protection

The coolant used in the liquid cooling module is a mixture of purified water and ethylene glycol with additional additives for corrosion resistance. Observe the following when cleaning up a coolant leak:

- The coolant might cause slight temporary eye irritation.
 - To prevent any accidental eye contact with the coolant, use safety glasses with side shields.
 - If eye contact occurs, immediately flush eye with plenty of water. If any discomfort persists, seek medical attention.
- The coolant might cause slight temporary skin irritation.
 - Use hand protection in the form of chemically resistant gloves when cleaning up coolant leak.
 - If gloves are not worn, wash hands with plenty of water after cleanup.

Server coolant leak

Symptom

A spill or leak of the electrically conductive server coolant is detected by iLO and the server has shut down automatically.

Cause

The supply hose of the liquid cooling module is damaged.

Action

Preparing for coolant leak cleanup

1. Have the following items ready for the coolant leak cleanup:
 - Dry paper towels or any absorbent material intended for cleaning up a chemical spill
 - Container to collect the leaked coolant
 - Dry cleanroom wipes
 - Deionized water
2. Read the following safety information:
 - [Rack warnings and cautions](#)
 - [Server warnings and cautions](#)

Assessing the spill

3. Inspect the server room first and determine if the spill has spread to other servers in the same rack.

Removing the server

4. If the server uses a DLC cold plate module, disconnect the DLC hoses from the rack manifolds.
5. If installed, [open the cable management arm](#).

6.



WARNING



To reduce the risk of electric shock, make sure that you use the necessary safety equipment compliant with local occupational health and safety code when disconnecting the power cords.

- Remove all power:
- a. Disconnect each power cord from the power source.
 - b. Disconnect each power cord from the server.
7. Disconnect all peripheral cables from the server.
 8. [Remove the server from the rack](#).
 9. Place the server on a flat, level work surface.

Locating the spill point

10. Observe proper eye and skin protection.
11. Remove the access panel.
12. Look for any potential contact between the coolant and any of the internal cables and components, especially power connectors.
13. Locate the spill point.
14. Cover the spill point with a dry absorbent material.

Cleaning up the coolant leak

15. Remove the leaky liquid cooling module. Avoid pushing out more coolant during removal.
16. Remove the system board.
17. If the leak has made it to the system board or the chassis, do the following:
 - a. Use a dry absorbent material to clean the coolant leak.
 - b. Wring the absorbed coolant into a container.
 - c. Lightly dampen a cleanroom wipe with deionized water. Wring out any excess water, and gently wipe over areas with coolant residue.
 - d. Ensure that there is no more visible colored coolant or liquid residue.
 - e. Dry the system board in a 70°C environment for at least 8 hours.
 - f. Confirm that the system board is completely dry before reinstallation.
18. Follow the procedure in the server maintenance and service guide to reinstall the system board.
19. Repeat steps 11–18 on other servers affected by the spill.

Handling waste

20. Fill the container with tap water and dispose of the residue in accordance with local safety requirements.
21. Use plenty of fresh water to clean the container used to collect the leaked coolant.
22. Dispose of used absorbent material and paper towels in accordance with local safety requirements.

Replacing damaged components

23.  **WARNING**
Water and electricity combined pose a significant safety hazard.
Hardware electrical components that have been in contact with the spilled coolant might be damaged.

24. To ensure a functional and safe server operation, identify and replace all damaged components.

Restoring system operation



IMPORTANT

After the spill is properly cleaned up, do not rush to power on the system immediately. Instead, leave the system in Standby Mode first and observe the front panel LEDs after connecting the power cables.

Verify if the system power LED is illuminated. If not, replace the system board.

25. In the iLO web interface or RESTful API, clear the coolant leakage status.

For the detailed procedure, see the iLO 7 user guide (<https://www.hpe.com/support/hpeilodocs-quicklinks>).

26. If the server uses a DLC cold plate module, reconnect the DLC hoses to the rack manifolds.

27. Power on the server.

If the system fails to boot, replace the system board.