



Hewlett Packard
Enterprise

HPE ProLiant Compute DL320 Gen12 Maintenance and Service Guide

Part Number: 30-8CEB6618-005a
Published: February 2026
Edition: 5a

HPE ProLiant Compute DL320 Gen12 Maintenance and Service Guide

Abstract

This document is for the person who installs, administers, and troubleshoots servers and storage systems. Hewlett Packard Enterprise assumes you are qualified in the servicing of computer equipment and trained in recognizing hazards in products with hazardous energy levels, and are familiar with the weight and stability precautions for rack installations.

Part Number: 30-8CEB6618-005a

Published: February 2026

Edition: 5a

© Copyright 2025–2026 Hewlett Packard Enterprise Development LP

Notices

The information provided here is subject to change without notice. Hewlett Packard Enterprise's products and services are covered only by the express warranty statements that come with them. This document does not constitute an additional warranty. Hewlett Packard Enterprise is not responsible for any technical or editorial errors or omissions in this document.

Confidential computer software. You must have a valid license from Hewlett Packard Enterprise to possess, use, or copy the software. In accordance with FAR 12.211 and 12.212, Commercial Computer Software, Computer Software Documentation, and Technical Data for Commercial Items are licensed to the U.S. Government under the vendor's standard commercial license.

Links to third-party websites will take you outside of the Hewlett Packard Enterprise website. Hewlett Packard Enterprise has no control over and is not responsible for the information outside the Hewlett Packard Enterprise website.

Acknowledgments

Intel® and Xeon® is a trademark of Intel Corporation or its subsidiaries.

Linux® is the registered trademark of Linus Torvalds in the U.S. and other countries.

Microsoft®, Windows®, and Windows Server® are either registered trademarks or trademarks of Microsoft Corporation in the United States and/or other countries.

VMware® is a registered trademark of VMware, Inc in the United States and other jurisdictions.

All third-party marks are property of their respective owners.

Table of contents

- Customer self repair
- Illustrated parts catalog
 - Mechanical components
 - Middle cover spare part
 - Cable management arm spare part
 - Miscellaneous blank spare parts
 - DIMM guard spare part
 - Rack rail spare parts
 - Chassis ears spare part
 - Hood pin spare part
 - E3.S drive filler spare part
 - Fan cable holder spare part
 - Energy pack holder spare part
 - Power supply bay bracket spare kit
 - System components
 - Power distribution board spare part
 - Power supply spare parts
 - System battery spare part
 - Processor spare parts
 - Heatsink spare parts
 - Closed-loop liquid cooling heatsink spare part
 - DIMM spare parts
 - Fan spare parts
 - Datacenter Secure Control Module spare part
 - System board spare part
 - Server options
 - Front OCP NIC carrier and bracket spare part
 - Front OCP NIC-related spare parts
 - Storage controller spare parts
 - Drive backplane spare parts
 - Serial port cable spare parts
 - Energy pack spare parts
 - HPE NS204i-u Boot Device V2 spare parts
 - Riser board spare part
 - Chassis intrusion detection switch spare part
 - Captive riser cable spare parts
 - GPU spare part
 - Drive cable spare parts
 - Rear OCP NIC interposer spare parts

- Rear OCP B enablement cable spare part
- Systems Insight Display spare part
- Removal and replacement procedures
 - Safety considerations
 - Electrostatic discharge
 - Symbols on equipment
 - Rack warnings and cautions
 - Server warnings and cautions
 - Preparation procedures
 - Server data backup
 - Power up the server
 - Power down the server
 - Release the cable management arm
 - Extend the server out of the rack
 - Remove the front bezel
 - Remove the access panel
 - Remove the middle cover
 - Remove the energy pack retention latch
 - Remove the fan wall
 - Remove the riser cage
 - Remove the server from the rack
 - Chassis ears replacement
 - Removing and replacing the left chassis ear
 - Removing and replacing the right chassis ear and front I/O assembly
 - Removing and replacing the Systems Insight Display power module
 - Removing and replacing a hot-plug drive
 - Removing and replacing a drive blank
 - Removing and replacing the cable management arm
 - Removing and replacing the middle cover
 - Power supply replacement
 - Power supply warnings and cautions
 - Removing and replacing a power supply
 - Removing and replacing the power supply bay filler
 - Removing and replacing a power supply blank
 - Removing and replacing the rack rails
 - Front OCP NIC kit replacement
 - Removing and replacing the front OCP NIC carrier kit
 - Removing and replacing a front OCP NIC adapter
 - Removing and replacing the front OCP NIC cable
 - Removing and replacing a E3.S drive filler
 - Removing and replacing the PHY board

- Removing and replacing the OCP NIC interposer
- Drive backplane replacement
 - Removing and replacing the 2 SFF drive backplane
 - Removing and replacing the 2 SFF or 4 E3.S drive backplane from the mixed or GPU-optimized drive configuration
 - Removing and replacing the 8 SFF drive backplane
 - Removing and replacing the 4 LFF drive backplane
 - Removing and replacing the 4 E3.S drive backplane
- Optical drive replacement
 - Removing and replacing the optical drive from the 8 SFF drive configuration
 - Removing and replacing an optical drive from the LFF drive configuration
 - Removing and replacing the optical disk drive from the mixed drive configuration
- Removing and replacing the hood pin
- Removing and replacing a fan
- Removing and replacing a fan cable holder
- Removing and replacing a DIMM
- Removing and replacing a DIMM guard
- Removing and replacing the chassis intrusion detection switch
- Removing and replacing the energy pack
- Removing and replacing the energy pack holder
- Removing and replacing an internal USB device
- Removing and replacing the power distribution board
- System battery replacement
 - System battery information
 - Removing and replacing the system battery
- Expansion card replacement
 - Removing and replacing a type-o storage controller
 - Removing and replacing a type-p storage controller
 - Removing and replacing an expansion card
- Removing and replacing a riser cage blank
- Riser board replacement
 - Removing and replacing a riser board
 - Removing and replacing the GPU captive riser
- GPU replacement
 - Removing and replacing a GPU from the GPU cage
 - Removing and replacing a GPU
- Removing and replacing an OCP adapter
- DC-SCM replacement
 - Removing the DC-SCM
 - Installing the DC-SCM
- Removing and replacing the ix port cable bracket
- Removing and replacing a serial port/ix port cable

- Removing and replacing the ix port blank
- Removing and replacing the HPE NS204i-u Boot Device V2 bracket
- HPE NS204i-u Boot Device V2 replacement
 - Removing and replacing the HPE NS204i-u Boot Device V2 from Box 3
 - Removing and replacing the HPE NS204i-u Boot Device V2 from the chassis
 - Removing and replacing HPE NS204i-u Boot Device V2 from the rear of the chassis
 - Removing and replacing the HPE NS204i-u Boot Device V2 cage from the power supply bay
 - Removing and replacing a boot device drive
- Heatsink replacement
 - Removing a heatsink
 - Removing a closed-loop liquid cooling heatsink
 - Installing the heatsink
 - Installing a closed-loop liquid cooling heatsink
- Processor replacement
 - Processor cautions
 - Removing the processor
 - Installing the processor
- System board replacement
 - Removing the system board
 - Installing the system board
 - Binding the DC-SCM with the HPM
 - Binding the DC-SCM with the HPM using the iLO web interface
 - Binding the DC-SCM with the HPM using the UEFI System Utilities
 - Resetting the iLO login credentials
 - Recovering the iLO default password using the iLO web interface
 - Recovering the iLO login credentials using iLO RESTful API
 - Re-entering the server serial number and product ID
- Component identification
 - Front panel components
 - Front panel LEDs and buttons
 - Rear panel components
 - Rear panel LEDs
 - System board and power distribution board components
 - System maintenance switch descriptions
 - DIMM slot numbering
 - DIMM label identification
 - Component touchpoints
 - System Insight Display LEDs
 - System Insight Display combined LED descriptions
 - Drive bay numbering
 - SFF drive bay numbering

- LFF drive bay numbering
- E3.S drive bay numbering
- Mixed drive bay numbering
- GPU-optimized configuration drive bay numbering
- HPE Basic Drive LED definitions
- EDSFF SSD LED definitions
- GPU riser slot numbering
- Drive backplane naming
- Fan numbering
- Heatsink and processor socket components
- Closed-loop liquid cooling components
- Liquid cooling guidelines
- Fan and heatsink requirements
- Datacenter Secure Control Module components
- OCP NIC 3.0 slot numbering
- HPE NS204i-u Boot Device V2 components
- HPE NS204i-u Boot Device V2 LED definitions
- Riser board components
- Troubleshooting
 - NMI functionality
 - Front panel LED power fault codes
 - Troubleshooting resources
- Cabling
 - Cabling guidelines
 - Internal cabling management
 - Cabling diagrams
 - Storage cabling
 - Drive power cabling
 - Storage controller cabling
 - SFF drive controller cabling
 - LFF drive controller cabling
 - E3.S drive controller cabling
 - Mixed drive controller cabling
 - GPU-optimized configuration drive controller cabling
 - Energy pack cabling
 - Storage controller backup power cabling
 - Fan cabling
 - Closed-loop liquid cooling heatsink cabling
 - HPE NS204i-u Boot Device V2 cabling
 - GPU cabling
 - GPU auxiliary power cabling

- GPU riser cabling
- Serial port cabling
- Optical drive cabling
- Display port cabling
- Systems Insight Display cabling
- Front OCP NIC and PHY board cabling
- Rear OCP upgrade cabling
- Front I/O cabling
- Chassis intrusion detection switch cabling
- Configuration resources
 - Updating firmware or system ROM
 - Configuring the server
 - Configuring storage controllers
 - Deploying an OS
 - Configuring security
 - Server management
 - Managing Linux-based high performance compute clusters
- Safety, warranty, and regulatory information
 - Regulatory information
 - Notices for Eurasian Economic Union
 - Turkey RoHS material content declaration
 - Ukraine RoHS material content declaration
 - Warranty information
- Specifications
 - Environmental specifications
 - Mechanical specifications
 - Power supply specifications
 - HPE 800 W M-CRPS Platinum Hot-plug Power Supply
 - HPE 1000 W M-CRPS Titanium Hot-plug Power Supply
 - HPE 1500 W M-CRPS Titanium Hot-plug Power Supply
 - HPE 2400 W M-CRPS Titanium Hot-plug Power Supply
- Appendix I: Server coolant spill response
 - Eye and skin protection
 - Server coolant leak
- Websites
- Support and other resources
 - Accessing Hewlett Packard Enterprise Support
 - HPE product registration
 - Accessing updates
 - Remote support
 - Documentation feedback

Customer self repair

Hewlett Packard Enterprise products are designed with many Customer Self Repair (CSR) parts to minimize repair time and allow for greater flexibility in performing defective parts replacement. If during the diagnosis period Hewlett Packard Enterprise (or Hewlett Packard Enterprise service providers or service partners) identifies that the repair can be accomplished by the use of a CSR part, Hewlett Packard Enterprise will ship that part directly to you for replacement. There are two categories of CSR parts:

- **Mandatory**—Parts for which customer self repair is mandatory. If you request Hewlett Packard Enterprise to replace these parts, you will be charged for the travel and labor costs of this service.
- **Optional**—Parts for which customer self repair is optional. These parts are also designed for customer self repair. If, however, you require that Hewlett Packard Enterprise replace them for you, there may or may not be additional charges, depending on the type of warranty service designated for your product.



NOTE

Some Hewlett Packard Enterprise parts are not designed for customer self repair. In order to satisfy the customer warranty, Hewlett Packard Enterprise requires that an authorized service provider replace the part. These parts are identified as "No" in the Illustrated Parts Catalog.

Based on availability and where geography permits, CSR parts will be shipped for next business day delivery. Same day or four-hour delivery may be offered at an additional charge where geography permits. If assistance is required, you can contact the Hewlett Packard Enterprise Support Center and a technician will help you over the telephone or by electronic means. Hewlett Packard Enterprise specifies in the materials shipped with a replacement CSR part whether a defective part must be returned to Hewlett Packard Enterprise. In cases where it is required to return the defective part to Hewlett Packard Enterprise, you must ship the defective part back to Hewlett Packard Enterprise within a defined period of time, normally five (5) business days. The defective part must be returned with the associated documentation in the provided shipping material. Failure to return the defective part may result in Hewlett Packard Enterprise billing you for the replacement. With a customer self repair, Hewlett Packard Enterprise will pay all shipping and part return costs and determine the courier/carrier to be used.

For more information about the Hewlett Packard Enterprise CSR program, contact your local service provider.

Parts only warranty service

Your Hewlett Packard Enterprise Limited Warranty may include a parts only warranty service. Under the terms of parts only warranty service, Hewlett Packard Enterprise will provide replacement parts free of charge.

For parts only warranty service, CSR part replacement is mandatory. If you request Hewlett Packard Enterprise to replace these parts, you will be charged for the travel and labor costs of this service.

Réparation par le client (CSR)

Les produits Hewlett Packard Enterprise comportent de nombreuses pièces CSR (Customer Self Repair = réparation par le client) afin de minimiser les délais de réparation et faciliter le remplacement des pièces défectueuses. Si pendant la période de diagnostic, Hewlett Packard Enterprise (ou ses partenaires ou mainteneurs agréés) détermine que la réparation peut être effectuée à l'aide d'une pièce CSR, Hewlett Packard Enterprise vous l'envoie directement. Il existe deux catégories de pièces CSR :

- **Obligatoire**—Pièces pour lesquelles la réparation par le client est obligatoire. Si vous demandez à Hewlett Packard Enterprise de remplacer ces pièces, les coûts de déplacement et main d'œuvre du service vous seront facturés.
- **Facultatif**—Pièces pour lesquelles la réparation par le client est facultative. Ces pièces sont également conçues pour permettre au client d'effectuer lui-même la réparation. Toutefois, si vous demandez à Hewlett Packard Enterprise de remplacer ces pièces, l'intervention peut ou non vous être facturée, selon le type de garantie applicable à votre produit.

REMARQUE: Certaines pièces Hewlett Packard Enterprise ne sont pas conçues pour permettre au client d'effectuer lui-même la réparation. Pour que la garantie puisse s'appliquer, Hewlett Packard Enterprise exige que le remplacement de la pièce soit effectué par un Mainteneur Agréé. Ces pièces sont identifiées par la mention "Non" dans le Catalogue illustré.

Les pièces CSR sont livrées le jour ouvré suivant, dans la limite des stocks disponibles et selon votre situation géographique. Si votre situation géographique le permet et que vous demandez une livraison le jour même ou dans les 4 heures, celle-ci vous sera facturée. Pour toute assistance, appelez le Centre d'assistance Hewlett Packard Enterprise pour qu'un technicien vous aide au téléphone. Dans les documents envoyés avec la pièce de rechange CSR, Hewlett Packard Enterprise précise s'il est nécessaire de lui retourner la pièce défectueuse. Si c'est le cas, vous devez le faire dans le délai indiqué, généralement cinq (5) jours ouvrés. La pièce et sa documentation doivent être retournées dans l'emballage fourni. Si vous ne retournez pas la pièce défectueuse, Hewlett Packard Enterprise se réserve le droit de vous facturer les coûts de remplacement. Dans le cas d'une pièce CSR, Hewlett Packard Enterprise supporte l'ensemble des frais

d'expédition et de retour, et détermine la société de courses ou le transporteur à utiliser.

Pour plus d'informations sur le programme CSR de Hewlett Packard Enterprise, contactez votre Mainteneur Agréé local.

Service de garantie "pièces seules"

Votre garantie limitée Hewlett Packard Enterprise peut inclure un service de garantie "pièces seules". Dans ce cas, les pièces de rechange fournies par Hewlett Packard Enterprise ne sont pas facturées.

Dans le cadre de ce service, la réparation des pièces CSR par le client est obligatoire. Si vous demandez à Hewlett Packard Enterprise de remplacer ces pièces, les coûts de déplacement et main d'œuvre du service vous seront facturés.

Riparazione da parte del cliente

Per abbreviare i tempi di riparazione e garantire una maggiore flessibilità nella sostituzione di parti difettose, i prodotti Hewlett Packard Enterprise sono realizzati con numerosi componenti che possono essere riparati direttamente dal cliente (CSR, Customer Self Repair). Se in fase di diagnostica Hewlett Packard Enterprise (o un centro di servizi o di assistenza Hewlett Packard Enterprise) identifica il guasto come riparabile mediante un ricambio CSR, Hewlett Packard Enterprise lo spedisce direttamente al cliente per la sostituzione. Vi sono due categorie di parti CSR:

- **Obbligatorie**—Parti che devono essere necessariamente riparate dal cliente. Se il cliente ne affida la riparazione ad Hewlett Packard Enterprise, deve sostenere le spese di spedizione e di manodopera per il servizio.
- **Opzionali**—Parti la cui riparazione da parte del cliente è facoltativa. Si tratta comunque di componenti progettati per questo scopo. Se tuttavia il cliente ne richiede la sostituzione ad Hewlett Packard Enterprise, potrebbe dover sostenere spese aggiuntive a seconda del tipo di garanzia previsto per il prodotto.

NOTA: alcuni componenti Hewlett Packard Enterprise non sono progettati per la riparazione da parte del cliente. Per rispettare la garanzia, Hewlett Packard Enterprise richiede che queste parti siano sostituite da un centro di assistenza autorizzato. Tali parti sono identificate da un "No" nel Catalogo illustrato dei componenti.

In base alla disponibilità e alla località geografica, le parti CSR vengono spedite con consegna entro il giorno lavorativo seguente. La consegna nel giorno stesso o entro quattro ore è offerta con un supplemento di costo solo in alcune zone. In caso di necessità si può richiedere l'assistenza telefonica di un addetto del centro di supporto tecnico Hewlett Packard Enterprise. Nel materiale fornito con una parte di ricambio CSR, Hewlett Packard Enterprise specifica se il cliente deve restituire dei componenti. Qualora sia richiesta la resa ad Hewlett Packard Enterprise del componente difettoso, lo si deve spedire ad Hewlett Packard Enterprise entro un determinato periodo di tempo, generalmente cinque (5) giorni lavorativi. Il componente difettoso deve essere restituito con la documentazione associata nell'imballo di spedizione fornito. La mancata restituzione del componente può comportare la fatturazione del ricambio da parte di Hewlett Packard Enterprise. Nel caso di riparazione da parte del cliente, Hewlett Packard Enterprise sostiene tutte le spese di spedizione e resa e sceglie il corriere/vettore da utilizzare.

Per ulteriori informazioni sul programma CSR di Hewlett Packard Enterprise, contattare il centro di assistenza di zona.

Servizio di garanzia per i soli componenti

La garanzia limitata Hewlett Packard Enterprise può includere un servizio di garanzia per i soli componenti. Nei termini di garanzia del servizio per i soli componenti, Hewlett Packard Enterprise fornirà gratuitamente le parti di ricambio.

Per il servizio di garanzia per i soli componenti è obbligatoria la formula CSR che prevede la riparazione da parte del cliente. Se il cliente invece richiede la sostituzione ad Hewlett Packard Enterprise dovrà sostenere le spese di spedizione e di manodopera per il servizio.

Customer Self Repair

Hewlett Packard Enterprise Produkte enthalten viele CSR-Teile (Customer Self Repair), um Reparaturzeiten zu minimieren und höhere Flexibilität beim Austausch defekter Bauteile zu ermöglichen. Wenn Hewlett Packard Enterprise (oder ein Hewlett Packard Enterprise Servicepartner) bei der Diagnose feststellt, dass das Produkt mithilfe eines CSR-Teils repariert werden kann, sendet Ihnen Hewlett Packard Enterprise dieses Bauteil zum Austausch direkt zu. CSR-Teile werden in zwei Kategorien unterteilt:

- **Zwingend**—Teile, für die das Customer Self Repair-Verfahren zwingend vorgegeben ist. Wenn Sie den Austausch dieser Teile von Hewlett Packard Enterprise vornehmen lassen, werden Ihnen die Anfahrt- und Arbeitskosten für diesen Service berechnet.
- **Optional**—Teile, für die das Customer Self Repair-Verfahren optional ist. Diese Teile sind auch für Customer Self Repair ausgelegt. Wenn Sie jedoch den Austausch dieser Teile von Hewlett Packard Enterprise vornehmen lassen möchten, können bei diesem Service je nach den für Ihr Produkt vorgesehenen Garantiebedingungen zusätzliche Kosten anfallen.

HINWEIS: Einige Hewlett Packard Enterprise Teile sind nicht für Customer Self Repair ausgelegt. Um den Garantieanspruch des Kunden zu erfüllen, muss das Teil von einem Hewlett Packard Enterprise Servicepartner ersetzt werden. Im illustrierten Teilekatalog sind diese Teile mit „No“ bzw. „Nein“ gekennzeichnet.

CSR-Teile werden abhängig von der Verfügbarkeit und vom Lieferziel am folgenden Geschäftstag geliefert. Für bestimmte Standorte ist eine Lieferung am selben Tag oder innerhalb von vier Stunden gegen einen Aufpreis verfügbar. Wenn Sie Hilfe benötigen, können Sie das Hewlett Packard Enterprise Support Center anrufen und sich von einem Mitarbeiter per Telefon helfen lassen. Den Materialien von Hewlett Packard Enterprise, die mit einem CSR-Ersatzteil geliefert werden, können Sie entnehmen, ob das defekte Teil an Hewlett Packard Enterprise zurückgeschickt werden muss. Wenn es erforderlich ist, das defekte Teil an Hewlett Packard Enterprise zurückzuschicken, müssen Sie dies innerhalb eines vorgegebenen Zeitraums tun, in der Regel innerhalb von fünf (5) Geschäftstagen. Das defekte Teil muss mit der zugehörigen Dokumentation in der Verpackung zurückgeschickt werden, die im Lieferumfang enthalten ist. Wenn Sie das defekte Teil nicht zurückschicken, kann Hewlett Packard Enterprise Ihnen das Ersatzteil in Rechnung stellen. Im Falle von Customer Self Repair kommt Hewlett Packard Enterprise für alle Kosten für die Lieferung und Rücksendung auf und bestimmt den Kurier-/Frachtdienst.

Weitere Informationen über das Hewlett Packard Enterprise Customer Self Repair Programm erhalten Sie von Ihrem Servicepartner vor Ort.

Parts-only Warranty Service (Garantieservice ausschließlich für Teile)

Ihre Hewlett Packard Enterprise Garantie umfasst möglicherweise einen Parts-only Warranty Service (Garantieservice ausschließlich für Teile). Gemäß den Bestimmungen des Parts-only Warranty Service stellt Hewlett Packard Enterprise Ersatzteile kostenlos zur Verfügung.

Für den Parts-only Warranty Service ist das CSR-Verfahren zwingend vorgegeben. Wenn Sie den Austausch dieser Teile von Hewlett Packard Enterprise vornehmen lassen, werden Ihnen die Anfahrt- und Arbeitskosten für diesen Service berechnet.

Reparaciones del propio cliente

Los productos de Hewlett Packard Enterprise incluyen muchos componentes que el propio usuario puede reemplazar (Customer Self Repair, CSR) para minimizar el tiempo de reparación y ofrecer una mayor flexibilidad a la hora de realizar sustituciones de componentes defectuosos. Si, durante la fase de diagnóstico, Hewlett Packard Enterprise (o los proveedores o socios de servicio de Hewlett Packard Enterprise) identifica que una reparación puede llevarse a cabo mediante el uso de un componente CSR, Hewlett Packard Enterprise le enviará dicho componente directamente para que realice su sustitución. Los componentes CSR se clasifican en dos categorías:

- **Obligatorio**—Componentes cuya reparación por parte del usuario es obligatoria. Si solicita a Hewlett Packard Enterprise que realice la sustitución de estos componentes, tendrá que hacerse cargo de los gastos de desplazamiento y de mano de obra de dicho servicio.
- **Opcional**—Componentes cuya reparación por parte del usuario es opcional. Estos componentes también están diseñados para que puedan ser reparados por el usuario. Sin embargo, si precisa que Hewlett Packard Enterprise realice su sustitución, puede o no conllevar costes adicionales, dependiendo del tipo de servicio de garantía correspondiente al producto.

NOTA: Algunos componentes de Hewlett Packard Enterprise no están diseñados para que puedan ser reparados por el usuario. Para que el usuario haga valer su garantía, Hewlett Packard Enterprise pone como condición que un proveedor de servicios autorizado realice la sustitución de estos componentes. Dichos componentes se identifican con la palabra "No" en el catálogo ilustrado de componentes.

Según la disponibilidad y la situación geográfica, los componentes CSR se enviarán para que lleguen a su destino al siguiente día laborable. Si la situación geográfica lo permite, se puede solicitar la entrega en el mismo día o en cuatro horas con un coste adicional. Si precisa asistencia técnica, puede llamar al Centro de asistencia técnica de Hewlett Packard Enterprise y recibirá ayuda telefónica por parte de un técnico. Con el envío de materiales para la sustitución de componentes CSR, Hewlett Packard Enterprise especificará si los componentes defectuosos deberán devolverse a Hewlett Packard Enterprise. En aquellos casos en los que sea necesario devolver algún componente a Hewlett Packard Enterprise, deberá hacerlo en el periodo de tiempo especificado, normalmente cinco días laborables. Los componentes defectuosos deberán devolverse con toda la documentación relacionada y con el embalaje de envío. Si no enviara el componente defectuoso requerido, Hewlett Packard Enterprise podrá cobrarle por el de sustitución. En el caso de todas sustituciones que lleve a cabo el cliente, Hewlett Packard Enterprise se hará cargo de todos los gastos de envío y devolución de componentes y escogerá la empresa de transporte que se utilice para dicho servicio.

Para obtener más información acerca del programa de Reparaciones del propio cliente de Hewlett Packard Enterprise, póngase en contacto con su proveedor de servicios local.

Servicio de garantía exclusivo de componentes

La garantía limitada de Hewlett Packard Enterprise puede que incluya un servicio de garantía exclusivo de componentes. Según las condiciones de este servicio exclusivo de componentes, Hewlett Packard Enterprise le facilitará los componentes de repuesto sin cargo adicional alguno.

Para este servicio de garantía exclusivo de componentes, es obligatoria la sustitución de componentes por parte del usuario (CSR). Si solicita a Hewlett Packard Enterprise que realice la sustitución de estos componentes, tendrá que hacerse cargo de los gastos de desplazamiento y de mano de obra de dicho servicio.

Customer Self Repair

Veel onderdelen in Hewlett Packard Enterprise producten zijn door de klant zelf te repareren, waardoor de reparatieduur tot een minimum beperkt kan blijven en de flexibiliteit in het vervangen van defecte onderdelen groter is. Deze onderdelen worden CSR-onderdelen (Customer Self Repair) genoemd. Als Hewlett Packard Enterprise (of een Hewlett Packard Enterprise Service Partner) bij de diagnose vaststelt dat de reparatie kan worden uitgevoerd met een CSR-onderdeel, verzendt Hewlett Packard Enterprise dat onderdeel rechtstreeks

naar u, zodat u het defecte onderdeel daarmee kunt vervangen. Er zijn twee categorieën CSR-onderdelen:

- **Verplicht**—Onderdelen waarvoor reparatie door de klant verplicht is. Als u Hewlett Packard Enterprise verzoekt deze onderdelen voor u te vervangen, worden u voor deze service reiskosten en arbeidsloon in rekening gebracht.
- **Optioneel**—Onderdelen waarvoor reparatie door de klant optioneel is. Ook deze onderdelen zijn ontworpen voor reparatie door de klant. Als u echter Hewlett Packard Enterprise verzoekt deze onderdelen voor u te vervangen, kunnen daarvoor extra kosten in rekening worden gebracht, afhankelijk van het type garanteservice voor het product.

OPMERKING: Sommige Hewlett Packard Enterprise onderdelen zijn niet ontwikkeld voor reparatie door de klant. In verband met de garantievoorzwaarden moet het onderdeel door een geautoriseerde Service Partner worden vervangen. Deze onderdelen worden in de geïllustreerde onderdelencatalogus aangemerkt met "Nee".

Afhankelijk van de leverbaarheid en de locatie worden CSR-onderdelen verzonden voor levering op de eerstvolgende werkdag. Levering op dezelfde dag of binnen vier uur kan tegen meerkosten worden aangeboden, indien dit mogelijk is gezien de locatie. Indien assistentie is gewenst, belt u het Hewlett Packard Enterprise Support Center om via de telefoon ondersteuning van een technicus te ontvangen. Hewlett Packard Enterprise vermeldt in de documentatie bij het vervangende CSR-onderdeel of het defecte onderdeel aan Hewlett Packard Enterprise moet worden geretourneerd. Als het defecte onderdeel aan Hewlett Packard Enterprise moet worden teruggezonden, moet u het defecte onderdeel binnen een bepaalde periode, gewoonlijk vijf (5) werkdagen, retourneren aan Hewlett Packard Enterprise. Het defecte onderdeel moet met de bijbehorende documentatie worden geretourneerd in het meegeleverde verpakkingsmateriaal. Als u het defecte onderdeel niet terugzendt, kan Hewlett Packard Enterprise u voor het vervangende onderdeel kosten in rekening brengen. Bij reparatie door de klant betaalt Hewlett Packard Enterprise alle verzendkosten voor het vervangende en geretourneerde onderdeel en kiest Hewlett Packard Enterprise zelf welke koerier/transportonderneming hiervoor wordt gebruikt.

Neem contact op met een Service Partner voor meer informatie over het Customer Self Repair programma van Hewlett Packard Enterprise.

Garanteservice "Parts Only"

Het is mogelijk dat de Hewlett Packard Enterprise garantie alleen de garanteservice "Parts Only" omvat. Volgens de bepalingen van de Parts Only garanteservice zal Hewlett Packard Enterprise kosteloos vervangende onderdelen ter beschikking stellen.

Voor de Parts Only garanteservice is vervanging door CSR-onderdelen verplicht. Als u Hewlett Packard Enterprise verzoekt deze onderdelen voor u te vervangen, worden u voor deze service reiskosten en arbeidsloon in rekening gebracht

Reparo feito pelo cliente

Os produtos da Hewlett Packard Enterprise são projetados com muitas peças para reparo feito pelo cliente (CSR) de modo a minimizar o tempo de reparo e permitir maior flexibilidade na substituição de peças com defeito. Se, durante o período de diagnóstico, a Hewlett Packard Enterprise (ou fornecedores/parceiros da Hewlett Packard Enterprise) concluir que o reparo pode ser efetuado pelo uso de uma peça CSR, a Hewlett Packard Enterprise enviará a peça diretamente ao cliente. Há duas categorias de peças CSR:

- **Obrigatória**—Peças cujo reparo feito pelo cliente é obrigatório. Se desejar que a Hewlett Packard Enterprise substitua essas peças, serão cobradas as despesas de transporte e mão-de-obra do serviço.
- **Opcional**—Peças cujo reparo feito pelo cliente é opcional. Essas peças também são projetadas para o reparo feito pelo cliente. No entanto, se desejar que a Hewlett Packard Enterprise as substitua, pode haver ou não a cobrança de taxa adicional, dependendo do tipo de serviço de garantia destinado ao produto.

OBSERVAÇÃO: Algumas peças da Hewlett Packard Enterprise não são projetadas para o reparo feito pelo cliente. A fim de cumprir a garantia do cliente, a Hewlett Packard Enterprise exige que um técnico autorizado substitua a peça. Essas peças estão identificadas com a marca "No" (Não), no catálogo de peças ilustrado.

Conforme a disponibilidade e o local geográfico, as peças CSR serão enviadas no primeiro dia útil após o pedido. Onde as condições geográficas permitirem, a entrega no mesmo dia ou em quatro horas pode ser feita mediante uma taxa adicional. Se precisar de auxílio, entre em contato com o Centro de suporte técnico da Hewlett Packard Enterprise para que um técnico o ajude por telefone. A Hewlett Packard Enterprise especifica nos materiais fornecidos com a peça CSR de reposição se a peça com defeito deve ser devolvida à Hewlett Packard Enterprise. Nos casos em que isso for necessário, é preciso enviar a peça com defeito à Hewlett Packard Enterprise, você deverá enviar a peça com defeito de volta para a Hewlett Packard Enterprise dentro do período de tempo definido, normalmente em 5 (cinco) dias úteis. A peça com defeito deve ser enviada com a documentação correspondente no material de transporte fornecido. Caso não o faça, a Hewlett Packard Enterprise poderá cobrar a reposição. Para as peças de reparo feito pelo cliente, a Hewlett Packard Enterprise paga todas as despesas de transporte e de devolução da peça e determina a transportadora/serviço postal a ser utilizado.

Para obter mais informações sobre o programa de reparo feito pelo cliente da Hewlett Packard Enterprise, entre em contato com o fornecedor de serviços local.

Serviço de garantia apenas para peças

A garantia limitada da Hewlett Packard Enterprise pode incluir um serviço de garantia apenas para peças. Segundo os termos do serviço de garantia apenas para peças, a Hewlett Packard Enterprise fornece as peças de reposição sem cobrar nenhuma taxa.

カスタマーセルフリペア

修理時間を短縮し、故障部品の交換における高い柔軟性を確保するために、Hewlett Packard Enterprise製品には多数のカスタマーセルフリペア（CSR）部品があります。診断の際に、CSR部品を使用すれば修理ができるHewlett Packard Enterprise（Hewlett Packard EnterpriseまたはHewlett Packard Enterprise正規保守代理店）が判断した場合、Hewlett Packard Enterpriseはその部品を直接、お客様に発送し、お客様に交換していただきます。CSR部品には以下の2種類があります。

- **必須** - カスタマーセルフリペアが必須の部品。当該部品について、もしもお客様がHewlett Packard Enterpriseに交換作業を依頼される場合には、その修理サービスに関する交通費および人件費がお客様に請求されます。
- **任意** - カスタマーセルフリペアが任意である部品。この部品もカスタマーセルフリペア用です。当該部品について、もしもお客様がHewlett Packard Enterpriseに交換作業を依頼される場合には、お買い上げの製品に適用される保証サービス内容の範囲内においては、別途費用を負担していただくことなく保証サービスを受けることができます。

注： Hewlett Packard Enterprise製品の一部の部品は、カスタマーセルフリペアの対象外です。製品の保証を継続するためには、Hewlett Packard EnterpriseまたはHewlett Packard Enterprise正規保守代理店による交換作業が必須となります。部品カタログには、当該部品がカスタマーセルフリペア除外品である旨が記載されています。

部品供給が可能な場合、地域によっては、CSR部品を翌営業日に届くように発送します。また、地域によっては、追加費用を負担いただくことにより同日または4時間以内に届くように発送することも可能な場合があります。サポートが必要なときは、Hewlett Packard Enterpriseサポートセンターに電話していただければ、技術者が電話でアドバイスします。交換用のCSR部品または同梱物には、故障部品をHewlett Packard Enterpriseに返送する必要があるかどうかが表示されています。故障部品をHewlett Packard Enterpriseに返送する必要がある場合は、指定期限内（通常は5営業日以内）に故障部品をHewlett Packard Enterpriseに返送してください。故障部品を返送する場合は、届いた時の梱包箱に関連書類とともに入れてください。故障部品を返送しない場合、Hewlett Packard Enterpriseから部品費用が請求されます。カスタマーセルフリペアの際には、Hewlett Packard Enterpriseは送料および部品返送費を全額負担し、使用する宅配便会社や運送会社を指定します。

部品のみ保証サービス

Hewlett Packard Enterprise保証サービスには、部品のみ保証サービスが適用される場合があります。このサービスでは、交換部品は無償で提供されます。

部品のみ保証サービスにおいては、CSR部品をお客様により交換作業していただくことが必須となります。当該部品について、もしもお客様がHewlett Packard Enterpriseに交換作業を依頼される場合には、その修理サービスに関する交通費および人件費がお客様のご負担となります。

客户自行维修

Hewlett Packard Enterprise 产品提供许多客户自行维修 (CSR) 部件，以尽可能缩短维修时间和在更换缺陷部件方面提供更大的灵活性。如果在诊断期间 Hewlett Packard Enterprise (或 Hewlett Packard Enterprise 服务提供商或服务合作伙伴) 确定可以通过使用 CSR 部件完成维修，Hewlett Packard Enterprise 将直接把该部件发送给您进行更换。有两类 CSR 部件：

- **强制性的** — 要求客户必须自行维修的部件。如果您请求 Hewlett Packard Enterprise 更换这些部件，则必须为该服务支付差旅费和人工费用。
- **可选的** — 客户可以选择是否自行维修的部件。这些部件也是为客户自行维修设计的。不过，如果您要求 Hewlett Packard Enterprise 为您更换这些部件，则根据为您的产品指定的保修服务类型，Hewlett Packard Enterprise 可能收取或不再收取任何附加费用。

注：某些 Hewlett Packard Enterprise 部件的设计并未考虑客户自行维修。为了满足客户保修的需要，Hewlett Packard Enterprise 要求授权服务提供商更换相关部件。这些部件在部件图解目录中标记为“否”。

CSR 部件将在下一个工作日发运（取决于备货情况和允许的地理范围）。在允许的地理范围内，可在当天或四小时内发运，但要收取额外费用。如果需要帮助，您可以致电 Hewlett Packard Enterprise 技术支持中心，将会有技术人员通过电话为您提供帮助。Hewlett Packard Enterprise 会在随更换的 CSR 部件发运的材料中指明是否必须将有缺陷的部件返还给 Hewlett Packard Enterprise。如果要求您将有缺陷的部件返还给 Hewlett Packard Enterprise，那么您必须在规定的期限内（通常是五 (5) 个工作日）将缺陷部件发给 Hewlett Packard Enterprise。有缺陷的部件必须随所提供的发运材料中的相关文件一起返还。如果未能送还有缺陷的部件，Hewlett Packard Enterprise 可能会要求您支付更换费用。客户自行维修时，Hewlett Packard Enterprise 将承担所有相关运输和部件返回费用，并指定快递商/承运商。

有关 Hewlett Packard Enterprise 客户自行维修计划的详细信息，请与您当地的服务提供商联系。

仅部件保修服务

您的 Hewlett Packard Enterprise 有限保修服务可能涉及仅部件保修服务。根据仅部件保修服务条款的规定，Hewlett Packard Enterprise 将免费提供更换的部件。

仅部件保修服务要求进行 CSR 部件更换。如果您请求 Hewlett Packard Enterprise 更换这些部件，则必须为该服务支付差旅费和人工费用。

客戶自行維修

Hewlett Packard Enterprise 產品設計了許多「客戶自行維修」(CSR) 的零件以減少維修時間，並且使得更換瑕疵零件時能有更大的彈性。如果在診斷期間，Hewlett Packard Enterprise (或 Hewlett Packard Enterprise 服務供應商或維修夥伴) 辨認出此項維修工作可以藉由使用 CSR 零件來完成，則 Hewlett Packard Enterprise 將直接寄送該零件給您作更換。CSR 零件分為兩種類別：

- **強制的** — 客戶自行維修所使用的零件是強制性的。如果您要求 Hewlett Packard Enterprise 更換這些零件，Hewlett Packard Enterprise 將會向您收取此服務所需的外出費用與勞動成本。
- **選購的** — 客戶自行維修所使用的零件是選購的。這些零件也設計用於客戶自行維修之用。不過，如果您要求 Hewlett Packard Enterprise 為您更換，則可能需要也可能不需要負擔額外的費用，端視針對此產品指定的保固服務類型而定。

備註：某些 Hewlett Packard Enterprise 零件沒有消費者可自行維修的設計。為符合客戶保固，Hewlett Packard Enterprise 需要授權的服務供應商更換零件。這些零件在圖示的零件目錄中，被標示為「否」。

基於材料取得及環境允許的情況下，CSR 零件將於下一個工作日以快遞寄送。在環境的允許下當天或四小時內送達，則可能需要額外的費用。若您需要協助，可致電 Hewlett Packard Enterprise 支援中心，會有一位技術人員透過電話來協助您。不論損壞的零件是否必須退回，Hewlett Packard Enterprise 皆會在與 CSR 替換零件一起運送的材料中註明。若要將損壞的零件退回 Hewlett Packard Enterprise，您必須在指定的一段時間內 (通常為五 (5) 個工作天)，將損壞的零件寄回 Hewlett Packard Enterprise。損壞的零件必須與寄送資料中隨附的相關技術文件一併退還。如果無法退還損壞的零件，Hewlett Packard Enterprise 可能要向您收取替換費用。針對客戶自行維修情形，Hewlett Packard Enterprise 將負責所有運費及零件退還費用，並指定使用何家快遞/貨運公司。

如需 Hewlett Packard Enterprise 的 CSR 方案詳細資訊，請連絡您當地的服務供應商。

僅限零件的保固服務

您的「Hewlett Packard Enterprise 有限保固」可能包含僅限零件的保固服務。在僅限零件的保固服務情況下，Hewlett Packard Enterprise 將免費提供替換零件。

針對僅限零件的保固服務，CSR 零件替換是強制性的。如果您要求 Hewlett Packard Enterprise 更換這些零件，Hewlett Packard Enterprise 將會向您收取此服務所需的外出費用與勞動成本。

고객 셀프 수리

Hewlett Packard Enterprise 제품은 수리 시간을 최소화하고 결함이 있는 부품 교체 시 더욱 융통성을 발휘할 수 있도록 하기 위해 고객 셀프 수리(CSR) 부품을 다량 사용하여 설계되었습니다. 진단 기간 동안 Hewlett Packard Enterprise(또는 Hewlett Packard Enterprise 서비스 공급업체 또는 서비스 협력업체)에서 CSR 부품을 사용하여 수리가 가능하다고 판단되면 Hewlett Packard Enterprise는 해당 부품을 바로 사용자에게 보내어 사용자가 교체할 수 있도록 합니다. CSR 부품에는 두 가지 종류가 있습니다.

- 필수 - 고객 셀프 수리가 의무 사항인 필수 부품. 사용자가 Hewlett Packard Enterprise에 이 부품의 교체를 요청할 경우 이 서비스에 대한 출장비 및 작업비가 청구됩니다.
- 선택 사항 - 고객 셀프 수리가 선택 사항인 부품. 이 부품들도 고객 셀프 수리가 가능하도록 설계되었습니다. 하지만 사용자가 Hewlett Packard Enterprise에 이 부품의 교체를 요청할 경우 사용자가 구입한 제품에 해당하는 보증 서비스 유형에 따라 추가 비용 없이 교체가 가능할 수 있습니다.

참고: 일부 Hewlett Packard Enterprise 제품은 고객 셀프 수리가 불가능하도록 설계되었습니다. Hewlett Packard Enterprise는 만족스러운 고객 보증을 위해 공인 서비스 제공업체를 통해 부품을 교체하도록 하고 있습니다. 이러한 부품들은 Illustrated Parts Catalog에 "No"라고 표시되어 있습니다.

CSR 부품은 재고 상태와 지리적 조건이 허용하는 경우 다음 영업일 납품이 가능하도록 배송이 이루어집니다. 지리적 조건이 허용하는 경우 추가 비용이 청구되는 조건으로 당일 또는 4시간 배송이 가능할 수도 있습니다. 도움이 필요하시면 Hewlett Packard Enterprise Support Center로 전화하십시오. 전문 기술자가 전화로 도움을 줄 것입니다. Hewlett Packard Enterprise는 결함이 발생한 부품을 Hewlett Packard Enterprise로 반환해야 하는지 여부를 CSR 교체 부품과 함께 배송된 자료에 지정합니다. 결함이 발생한 부품을 Hewlett Packard Enterprise로 반환해야 하는 경우에는 지정된 기간 내(통상 영업일 기준 5일)에 Hewlett Packard Enterprise로 반환해야 합니다. 이때 결함이 발생한 부품은 제공된 포장 재료에 넣어 관련 설명서와 함께 반환해야 합니다. 결함이 발생한 부품을 반환하지 않는 경우 Hewlett Packard Enterprise가 교체 부품에 대해 비용을 청구할 수 있습니다. 고객 셀프 수리의 경우, Hewlett Packard Enterprise는 모든 운송 및 부품 반환 비용을 부담하며 이용할 운송업체 및 택배 서비스를 결정합니다.

Hewlett Packard Enterprise CSR 프로그램에 대한 자세한 내용은 가까운 서비스 제공업체에 문의하십시오.

부품 제공 보증 서비스

Hewlett Packard Enterprise 제한 보증에는 부품 제공 보증 서비스가 포함될 수 있습니다. 이러한 경우 Hewlett Packard Enterprise는 부품 제공 보증 서비스의 조건에 따라 교체 부품만을 무료로 제공합니다.

부품 제공 보증 서비스 제공 시 CSR 부품 교체는 의무 사항입니다. 사용자가 Hewlett Packard Enterprise에 이 부품의 교체를 요청할 경우 이 서비스에 대한 출장비 및 작업비가 청구됩니다.

Illustrated parts catalog

This chapter lists the hardware spare parts supported by the server.

Subtopics

[Mechanical components](#)

[System components](#)

[Server options](#)

Mechanical components

Hewlett Packard Enterprise continually improves and changes product parts. For complete and current supported spare parts information, see the Hewlett Packard Enterprise PartSurfer website:

<https://www.hpe.com/info/partssurfer>

https://sketchfab.com/models/a1e4daea34c142b7ad0413331a715f40/embed?ui_infos=0&ui_watermark=0&ui_help=0&ui_vr=0&ui_settings=0&ui_inspector=0&ui_hint=2&ui_color=01a982&ui_theme=dark&autostart=1&camera=0&ui_animations=0

Item	Description
1	Left chassis ear spare part
2	Middle cover spare part
3	Hood pin spare part
4	Fan cable holder spare part
5	Energy pack bracket spare part
6	Power supply blank spare part
7	Left DIMM guard spare part
8	Full-height riser cage blank
9	Low-profile riser cage blank
10	Right DIMM guard spare part
11	Right chassis ear spare part
12	Cable management arm spare part*
13	Rack rail spare parts*
14	E3.S drive filler spare part*
15	Power supply bay bracket spare kit*

* Not shown

Subtopics

- [Middle cover spare part](#)
- [Cable management arm spare part](#)
- [Miscellaneous blank spare parts](#)
- [DIMM guard spare part](#)
- [Rack rail spare parts](#)
- [Chassis ears spare part](#)
- [Hood pin spare part](#)
- [E3.S drive filler spare part](#)
- [Fan cable holder spare part](#)
- [Energy pack holder spare part](#)
- [Power supply bay bracket spare kit](#)

Middle cover spare part

Customer self repair: **Mandatory**

Replacement procedure: [Removing and replacing the middle cover](#)

Description	Spare PN
SFF drive middle cover	P74410-001
LFF drive middle cover	P59453-001
Mixed drive middle cover	P79877-001

Cable management arm spare part

Customer self repair: Mandatory

Replacement procedure: Removing and replacing the cable management arm.

Description	Spare PN
Cable management arm #4	P74370-001
Cable management arm #6	P74408-001

Miscellaneous blank spare parts

Customer self repair: Mandatory

Replacement procedure:

- Removing and replacing a power supply blank
- Removing and replacing a riser cage blank

Description	Spare PN
60 mm power supply blank	P74013-001
73.5 mm power supply blank	P76290-001
Full-height riser cage blank	P79871-001
Low-profile riser cage blank	P79874-001

DIMM guard spare part

Customer self repair: Mandatory

Replacement procedure: Removing and replacing a DIMM guard

Description	Spare PN
Left DIMM guard	P80153-001
Right DIMM guard	P80154-001

Rack rail spare parts

Customer self repair: Mandatory

Replacement procedure: Removing and replacing the rack rails

Description	Spare PN
Friction rack rail #1	P59489-001
Friction rack rail #2	P59490-001
Friction rack rail #9	P59491-001
Friction rack rail #14	P74409-001

Chassis ears spare part

Customer self repair: Mandatory

Replacement procedure: Chassis ears replacement

Description	Spare PN
Left chassis ear	P56499-001
Right chassis ear assembly	P79636-001
*	
Right chassis ear assembly	P79879-001
12 LFF drive configuration right chassis ear assembly	P79879-001

* This spare part includes the chassis ear with the front I/O and USB cable.

Hood pin spare part

Customer self repair: Mandatory

Replacement procedure: Removing and replacing the hood pin

Description	Spare PN
Hood pin	P80155-001

E3.S drive filler spare part

Customer self repair: Mandatory

Replacement procedure: Removing and replacing a E3.S drive filler

Description	Spare part number
E3.S drive filler	P74372-001

Fan cable holder spare part

Customer self repair: Mandatory

Replacement procedure: Removing and replacing a fan cable holder

Description	Spare part number
Fan cable holder	P74377-001

Energy pack holder spare part

Customer self repair: Mandatory

Replacement procedure: Removing and replacing the energy pack holder

Description	Spare part number
-------------	-------------------

Energy pack holder	P74403-001
--------------------	------------

Power supply bay bracket spare kit

Customer self repair: Mandatory

Replacement procedure:

- Removing and replacing the HPE NS204i-u Boot Device V2 bracket
- Removing and replacing the ix port cable bracket
- Removing and replacing the power supply bay filler

Description	Spare PN
-------------	----------

This power supply bay bracket kit includes: P75501-001

- HPE NS204i-u Boot Device V2 bracket
- ix port cable bracket
- Power supply bay 1 filler
- Power supply bay 2 filler

System components

Hewlett Packard Enterprise continually improves and changes product parts. For complete and current supported spare parts information, see the Hewlett Packard Enterprise PartSurfer website:

<https://www.hpe.com/info/partssurfer>

https://sketchfab.com/models/52cce479133d4b81a6dac16ae8d3760f/embed?ui_infos=0&ui_watermark=0&ui_help=0&ui_vr=0&ui_settings=0&ui_inspector=0&ui_hint=2&ui_color=01a982&ui_theme=dark&autostart=1&camera=0&ui_animations=0

Item	Description
1	<u>Performance heatsink spare part</u>
2	<u>Processor spare parts</u>
3	<u>Power distribution board spare part</u>
4	<u>Power supply spare parts</u>
5	<u>DIMM spare parts</u>
6	<u>Datacenter Secure Control Module spare part</u>
7	<u>System board spare part</u>
8	<u>Fan spare parts*</u>
9	<u>System battery spare part*</u>

* Not shown

Subtopics

- [Power distribution board spare part](#)
- [Power supply spare parts](#)
- [System battery spare part](#)
- [Processor spare parts](#)
- [Heatsink spare parts](#)
- [Closed-loop liquid cooling heatsink spare part](#)
- [DIMM spare parts](#)
- [Fan spare parts](#)
- [Datacenter Secure Control Module spare part](#)
- [System board spare part](#)

Power distribution board spare part

Customer self repair: Mandatory

Replacement procedure: Removing and replacing the power distribution board

Description	Spare PN
Power distribution board	P73860-001

Power supply spare parts

Customer self repair: Mandatory

Replacement procedure: Power supply replacement

Description	Spare PN
HPE 800 W M-CRPS Platinum Hot-plug Power Supply (94% efficiency)	P77518-001
HPE 1000 W M-CRPS Titanium Hot-plug Power Supply (96% efficiency)	P68455-001
HPE 1500 W M-CRPS Titanium Hot-plug Power Supply (96% efficiency)	P68456-001
HPE 2400 W M-CRPS Titanium Hot-plug Power Supply (96% efficiency)	P68454-001

System battery spare part

Customer self repair: Mandatory

Replacement procedure: Removing and replacing the system battery

Description	Spare part number
3.0-V lithium battery coin (CR2032)	319603-001

Processor spare parts

Customer self repair: Optional

Replacement procedure: Processor replacement

Description	Spare PN
Intel Xeon 6500 Series Processors with Performance Cores (P-cores)	—
Intel Xeon 6505P, 2.20 GHz, 12C, 150 W	P80285-001
Intel Xeon 6507P, 3.50 GHz, 8C, 150 W	P80286-001
Intel Xeon 6511P, 2.30 GHz, 16C, 150 W	P80287-001
Intel Xeon 6515P, 2.40 GHz, 16C, 150 W	P80288-001
Intel Xeon 6517P, 3.20 GHz, 16C, 190 W	P80289-001
Intel Xeon 6520P, 2.40 GHz, 24C, 210 W	P80278-001
Intel Xeon 6521P, 2.6 GHz, 24C, 225 W	P80279-001
Intel Xeon 6527P, 3.00 GHz, 24C, 255 W	P80280-001
Intel Xeon 6530P, 2.30 GHz, 32C, 225 W	P80281-001
Intel Xeon 6700 Series Processors with Efficient Cores (E-cores)	—
Intel Xeon 6710E, 2.40 GHz, 64C, 205 W	P72411-001
Intel Xeon 6731E, 2.20 GHz, 96C, 250 W	P72412-001
Intel Xeon 6740E, 2.40 GHz, 96C, 250 W	P72413-001
Intel Xeon 6746E, 2.00 GHz, 112C, 250 W	P72414-001
Intel Xeon 6756E, 1.80 GHz, 128C, 225 W	P72415-001
Intel Xeon 6766E, 1.90 GHz, 144C, 250 W	P72416-001
Intel Xeon 6780E, 2.20 GHz, 144C, 330W	P72417-001
Intel Xeon 6700 Series Processors with Performance Cores (P-cores)	—
Intel Xeon 6725P, 3.7 GHz, 16C, 235 W	P87398-001
Intel Xeon 6730P, 2.50 GHz, 32C, 250 W	P78738-001
Intel Xeon 6731P, 2.5 GHz, 32C, 245 W	P80282-001
Intel Xeon 6732P, 3.8 GHz, 32C, 350 W	P82217-001
Intel Xeon 6736P, 2 GHz, 36C, 205 W	P80283-001
Intel Xeon 6737P, 2.9 GHz, 32C, 270 W	P80284-001
Intel Xeon 6740P, 2.10 GHz, 48C, 270 W	P78691-001
Intel Xeon 6741P, 2.50 GHz, 48C, 300 W	P78692-001
Intel Xeon 6745P, 3.1 GHz, 32C, 300 W	P82218-001
Intel Xeon 6747P, 2.70 GHz, 48C, 330 W	P78693-001
Intel Xeon 6760P, 2.20 GHz, 64C, 330 W	P78694-001
Intel Xeon 6761P, 2.50 GHz, 64C, 350 W	P78695-001
Intel Xeon 6767P, 2.40 GHz, 64C, 350 W	P78696-001
Intel Xeon 6781P, 2.00 GHz, 80C, 350 W	P78697-001
Intel Xeon 6787P, 2.00 GHz, 86C, 350 W	P78698-001

Heatsink spare parts

Customer self repair: **Optional**

Replacement procedure: [Heatsink replacement](#)

Description	Spare PN
Standard heatsink	P53219-001
Performance heatsink	P72477-001

Closed-loop liquid cooling heatsink spare part

Customer self repair: No

Replacement procedure: [Heatsink replacement](#)

Description	Spare PN
Closed-loop liquid cooling heatsink	P75932-001

DIMM spare parts

Customer self repair: Mandatory

Replacement procedure: [Removing and replacing a DIMM](#)

Description	Spare part number
16 GB, single-rank x8 PC5-6400B-R	P71254-001
32 GB, dual-rank x8 PC5-6400B-R	P71255-001
64 GB, dual-rank x4 PC5-6400B-R	P71256-001
96 GB, dual-rank x4 PC5-6400B-R	P71257-001
128 GB, dual-rank x4 PC5-6400B-R	P71258-001
256 GB, quad-rank x4 PC5-6400B-R 3DS	P75947-001

Fan spare parts

Customer self repair: Mandatory

Replacement procedure: [Removing and replacing a fan](#)

Description	Spare PN
Standard fan	P72478-001
Performance fan	P72479-001
Liquid cooling fan	P72480-001

Datacenter Secure Control Module spare part

Customer self repair: Optional

Replacement procedure: [DC-SCM replacement](#)

After installing the new DC-SCM, bind it with the system board (HPM) using the iLO login credentials on the toe tag that ships with the DC-

SCM spare. The binding process creates a trust relationship between the HPM and the DC-SCM.

Description	Spare PN
HPE ProLiant Compute iLO 7 DC-SCM	P79809-001

System board spare part

Customer self repair: Optional

Replacement procedure: System board replacement

This server is a Datacenter Secure Control Module (DC-MHS)-based product.

After installing the new system board, bind it with the DC-SCM. The binding process creates a trust relationship between the HPM and the DC-SCM. This relationship enables the system to detect any unauthorized HPM replacement.

When binding a new system board with an existing DC-SCM, the customer iLO login credentials are required.

Description	Spare PN
System board (HPM)	P79880-001

Server options

Hewlett Packard Enterprise continually improves and changes product parts. For complete and current supported spare parts information, see the Hewlett Packard Enterprise PartSurfer website:

<https://www.hpe.com/info/partssurfer>

https://sketchfab.com/models/feb25db5ef9242bca96097bbc85c7383/embed?ui_infos=0&ui_watermark=0&ui_help=0&ui_vr=0&ui_settings=0&ui_inspector=0&ui_hint=2&ui_color=01a982&ui_theme=dark&autostart=1&camera=0&ui_animations=0

Item	Description
1	Front OCP NIC carrier spare parts
2	Drive backplane spare parts
3	Storage controller spare parts
4	Riser board spare part
5	HPE NS204i-u Boot Device V2 spare parts
6	Rear OCP interposer spare part
7	Drive cable spare parts*
8	Serial port cable spare parts*
9	Front OCP NIC cable spare parts*
10	Chassis intrusion detection switch spare part*
11	Captive riser spare part*
12	GPU spare part*
13	Systems Insight Display spare part*
14	Rear OCP B enablement cable spare part*

* Not shown

Subtopics

[Front OCP NIC carrier and bracket spare part](#)

[Front OCP NIC-related spare parts](#)

[Storage controller spare parts](#)

[Drive backplane spare parts](#)

[Serial port cable spare parts](#)

[Energy pack spare parts](#)

[HPE NS204i-u Boot Device V2 spare parts](#)

[Riser board spare part](#)

[Chassis intrusion detection switch spare part](#)

[Captive riser cable spare parts](#)

[GPU spare part](#)

[Drive cable spare parts](#)

[Rear OCP NIC interposer spare parts](#)

[Rear OCP B enablement cable spare part](#)

[Systems Insight Display spare part](#)

Front OCP NIC carrier and bracket spare part

Customer self repair: Optional

Replacement procedure: [Removing and replacing the front OCP NIC carrier kit](#)

Description	Spare part number
Front OCP NIC carrier and bracket spare kit includes:	P79872-001
<ul style="list-style-type: none">• OCP NIC carrier• OCP NIC bracket	

Front OCP NIC-related spare parts

Customer self repair: Mandatory

Replacement procedure: [Removing and replacing the PHY board](#)

Description	Spare PN
PHY board	P76348-001

Customer self repair: Optional

Replacement procedure: [Removing and replacing the front OCP NIC cable](#)

Description	Spare PN
Primary and secondary front OCP NIC cable:	P71941-001 P77887-001
OCP NIC Interposer cable:	P73927-001 P75434-001

Storage controller spare parts

Customer self repair: Optional

Replacement procedure:

- [Removing and replacing a type-o storage controller](#)
- [Removing and replacing a type-p storage controller](#)

Description	Spare PN
HPE type-o controllers	
HPE MR216i-o Gen11 controller	P47954-001
HPE MR408i-o Gen11 controller	P58543-001
HPE MR416i-o Gen11 controller	P47952-001
HPE type-p controllers	
HPE MR216i-p Gen11 controller	P47953-001
HPE MR408i-p Gen11 controller	P74945-001
HPE MR416i-p Gen11 controller	P47951-001
HPE MR932i-p controller	P75933-001

Drive backplane spare parts

4 LFF drive backplane spare part

Customer self repair: Optional

Replacement procedure: [Removing and replacing the 4 LFF drive backplane](#)

Description	Spare PN
4 LFF 12G x1 U.2 SAS / SATA UBM2 LP	P40451-001

2 SFF drive backplane spare parts

Customer self repair: Mandatory

Replacement procedure:

- [Removing and replacing the 2 SFF drive backplane](#)
- [Removing and replacing the 2 SFF or 4 E3.S drive backplane from the mixed or GPU-optimized drive configuration](#)

Description	Spare PN
2 SFF 24G x4 NVMe/SAS UBM3 BC BP	P39306-001

Customer self repair: Optional

Description	Spare PN
2 SFF 24G x4 NVMe/SAS UBM3 BC BP	P39783-001
2 SFF 16G x4 NVMe UBM10 BC BP	P73069-001
2 SFF 16G x4 NVMe UBM4 BC BP (side-by-side)	P40859-001

8 SFF drive backplane spare parts

Customer self repair: Mandatory

Replacement procedure: [Removing and replacing the 8 SFF drive backplane](#)

Description	Spare PN
8 SFF 24G x1 U.3 NVMe / SAS UBM3 BC	P36059-001
8 SFF 24G x1 U.3 NVMe / SAS UBM6 BC	P40444-001
8 SFF 24G x4 U.3 NVMe / SAS UBM3 BC	P31226-001
8 SFF 24G x4 U.3 NVMe / SAS UBM6 BC	P40445-001

E3.S drive backplane spare part

Customer self repair: **Optional**

Replacement procedure: [Removing and replacing the 4 E3.S drive backplane](#)

Description	Spare PN
4 E3.S 32G x4 NVMe UBM10 EC	P73067-001

Serial port cable spare parts

Customer self repair: **Mandatory**

Replacement procedure: [Removing and replacing a serial port/ix port cable](#)

Cable description and part number

Spare part number	Description
P74016-001	Serial port dongle: P71826-001
P74373-001	ix port cable: P73744-001

Energy pack spare parts

Customer self repair: **Mandatory**

Replacement procedure: [Removing and replacing the energy pack](#)

Description	Spare part number
HPE 96 W Smart Storage Battery with 145 mm (5.7 in) cable	878643-001
HPE 12 W Smart Hybrid Capacitor with 145 mm (5.7 in) cable	P07473-001

HPE NS204i-u Boot Device V2 spare parts

Customer self repair: **Optional**

Replacement procedure: [HPE NS204i-u Boot Device V2 replacement](#)



IMPORTANT

For successful RAID 1 configuration, verify that the boot device SSDs have the same model number and firmware version:

- In the iLO web interface, see the Storage page.
- In UEFI System Utilities, see System Configuration > HPE NS204i Boot Controller > Physical Device Information.

Configurations with SSDs from different manufacturers are not supported.

Description and cable PN	Spare PN
HPE NS204i-u Boot Device V2	P78425-001
M.2 SSD carrier	P59777-001
480 GB NVMe RI M.2 SV 2280 SSD	P69616-001
Front HPE NS204i-u Boot Device V2 power cable: P48956-001	P56479-001
Front HPE NS204i-u Boot Device V2 signal cable: P72024-001	P74017-001
Front HPE NS204i-u Boot Device V2 signal cable: P74730-001	P76890-001
Rear HPE NS204i-u Boot Device V2 signal cable: P71913-001	P74376-001
Rear HPE NS204i-u Boot Device V2 power cable: P63720-001	P67335-001

Riser board spare part

Customer self repair: **Mandatory**

Replacement procedure:

- [Removing and replacing a riser board](#)
- [Removing and replacing the GPU captive riser](#)

Description	Spare PN
Captive riser spare part	P76299-001
PCIe5 x16 riser board	P74260-001

Chassis intrusion detection switch spare part

Customer self repair: **Mandatory**

Replacement procedure: [Removing and replacing the chassis intrusion detection switch](#)

Description	Spare PN
Chassis intrusion detection switch	875570-001

Captive riser cable spare parts

Customer self repair: **Optional**

Cable description and PN	Spare PN
Slot 4 captive riser signal cable: P73415-001	P77886-001
Slot 5 captive riser signal cable: P71886-001	P76023-001

GPU spare part

Customer self repair: Optional

Replacement procedure: [Removing and replacing a GPU](#)

Description	Spare PN
NVIDIA L4 24 GB PCIe GPU	P59360-001
NVIDIA L40S 48 GB PCIe GPU	P67869-001

Customer self repair: Mandatory

Cable description and PN	Spare PN
GPU auxiliary power cable: P75256-001	P77846-001

Drive cable spare parts

Customer self repair: Optional

Cable description and PN	Spare PN
LFF drive cable spare parts	—
12 LFF type-p controller cable:	P60390-001
P58063-001	P58518-001
P54931-001	
4 LFF drive type-o controller cable: P53989-001	P58517-001
4 LFF drive type-p controller cable: P54931-001	P58518-001
12 LFF drive type-o controller cable: P54928-001	P58519-001
SFF drive cable spare parts	—
2 SFF signal cable:	
• P74810-001	• P77869-001
• P71910-001	• P74036-001
2 SFF drive type-p controller cable: P53972-001	P58514-001
2 SFF drive type-o controller cable:	
• P75589-001	• P77901-001
• P48960-001	• P56484-001
8 SFF drive type-p controller cable: P45611-001	P53222-001
E3.S drive cable spare parts	—

Cable description and PN	Spare PN
8 E3.S drive direct attached cables	<ul style="list-style-type: none"> • P77883-001 • P77892-001 • P76906-001
16 E3.S drive direct attached cables	<ul style="list-style-type: none"> • P77893-001 • P77894-001
16 E3.S drive type-p controller cable: P75590-001	P77371-001
20 E3.S drive direct attached cables	<ul style="list-style-type: none"> • P77878-001 • P77879-001 • P77880-001 • P77881-001
20 E3.S drive cables to the type-p primary riser: P75593-001	P77890-001
8 E3.S drive cable to the type-p primary riser: P75588-001	P77876-001
Drive power cable spare parts	—
4 SFF drive power cable: P75582-001	P77888-001
2 SFF drive to 8 SFF drive power cable: P54591-001	P58494-001
8 SFF drive power cable: P71911-001	P74014-001
LFF drive box 5 power cable: P75583-001	P77870-001
LFF drive box 3 power cable: P75584-001	P77871-001
LFF drive box 1 power cable: P75585-001	P77872-001
20 E3.S drive power cable: P75586-001	P77889-001

Customer self repair: Mandatory

Cable description and PN	Spare PN
E3.S drive cable spare parts	—
16/20 E3.S drive cable to the MR932i-p controller: P75581-001	P77891-001
8 E3.S drive cable from Box 1 and 2 to the MR932i-p controller: P75575-001	P77877-001
12/16 E3.S drive cable from Box 1 and 2 to the MR932i-p controller: P75318-001	P80135-001
4/16 E3.S drive cable from Box 4 and 5 to the MR932i-p controller: P75570-001	P84599-001

Rear OCP NIC interposer spare parts

Customer self repair: Mandatory

Replacement procedure: Removing and replacing the OCP NIC interposer

Description	Spare PN
Slot 20 OCP A NIC interposer	P76350-001
Slot 21 OCP B NIC interposer	P76350-002

Rear OCP B enablement cable spare part

Customer self repair: Optional

Cable description and PN	Spare PN
OCP B upgrade enablement cable	<ul style="list-style-type: none">P77884-001P77885-001
<ul style="list-style-type: none">P75506-001P75507-001	

OCP B enablement cables for rich I/O configurations: P75591-001 P77882-001

Systems Insight Display spare part

Customer self repair: Mandatory

Replacement procedure: Removing and replacing the Systems Insight Display power module

Description	Spare PN
Systems Insight Display module	P79873-001

Removal and replacement procedures

This chapter provides detailed instructions on how to remove and replace component spare parts.

Subtopics

[Safety considerations](#)

[Preparation procedures](#)

[Chassis ears replacement](#)

[Removing and replacing the Systems Insight Display power module](#)

[Removing and replacing a hot-plug drive](#)

[Removing and replacing a drive blank](#)

[Removing and replacing the cable management arm](#)

[Removing and replacing the middle cover](#)

[Power supply replacement](#)

[Removing and replacing the rack rails](#)

[Front OCP NIC kit replacement](#)

[Drive backplane replacement](#)

[Optical drive replacement](#)

[Removing and replacing the hood pin](#)
[Removing and replacing a fan](#)
[Removing and replacing a fan cable holder](#)
[Removing and replacing a DIMM](#)
[Removing and replacing a DIMM guard](#)
[Removing and replacing the chassis intrusion detection switch](#)
[Removing and replacing the energy pack](#)
[Removing and replacing the energy pack holder](#)
[Removing and replacing an internal USB device](#)
[Removing and replacing the power distribution board](#)
[System battery replacement](#)
[Expansion card replacement](#)
[Removing and replacing a riser cage blank](#)
[Riser board replacement](#)
[GPU replacement](#)
[Removing and replacing an OCP adapter](#)
[DC-SCM replacement](#)
[Removing and replacing the ix port cable bracket](#)
[Removing and replacing a serial port/ix port cable](#)
[Removing and replacing the ix port blank](#)
[Removing and replacing the HPE NS204i-u Boot Device V2 bracket](#)
[HPE NS204i-u Boot Device V2 replacement](#)
[Heatsink replacement](#)
[Processor replacement](#)
[System board replacement](#)

Safety considerations

Before performing service procedures, review all the safety information.

Subtopics

[Electrostatic discharge](#)
[Symbols on equipment](#)
[Rack warnings and cautions](#)
[Server warnings and cautions](#)

Electrostatic discharge

Be aware of the precautions you must follow when setting up the system or handling components. A discharge of static electricity from a finger or other conductor may damage system boards or other static-sensitive devices. This type of damage may reduce the life expectancy of the system or component.

To prevent electrostatic damage:

- Avoid hand contact by transporting and storing products in static-safe containers.
- Keep electrostatic-sensitive parts in their containers until they arrive at static-free workstations.
- Place parts on a grounded surface before removing them from their containers.
- Avoid touching pins, leads, or circuitry.
- Always be properly grounded when touching a static-sensitive component or assembly. Use one or more of the following methods when handling or installing electrostatic-sensitive parts:

- Use a wrist strap connected by a ground cord to a grounded workstation or computer chassis. Wrist straps are flexible straps with a minimum of 1 megohm ±10 percent resistance in the ground cords. To provide proper ground, wear the strap snug against the skin.
- Use heel straps, toe straps, or boot straps at standing workstations. Wear the straps on both feet when standing on conductive floors or dissipating floor mats.
- Use conductive field service tools.
- Use a portable field service kit with a folding static-dissipating work mat.

If you do not have any of the suggested equipment for proper grounding, have an authorized reseller install the part.

For more information on static electricity or assistance with product installation, contact an authorized reseller.

Symbols on equipment

The following symbols may be placed on equipment to indicate the presence of potentially hazardous conditions:



This symbol in conjunction with any of the following symbols indicates the presence of a potential hazard. The potential for injury exists if warnings are not observed. Consult your documentation for specific details.

該符號與以下任意符號組合使用，指示存在潛在的危險。如果不遵守警告，可能會造成人身傷害。詳細信息請參閱相關文檔。



This symbol indicates the presence of hazardous energy circuits or electric shock hazards. Refer all servicing to qualified personnel.



WARNING

To reduce the risk of injury from electric shock hazards, do not open this enclosure. Refer all maintenance, upgrades, and servicing to qualified personnel.

此符號表明存在危險電路或觸電的危險。所有維修工作應由具有相關資格的人員來完成。

警告：為了減少觸電造成人身傷害的危險，請不要打開此外殼。所有維護、升級和維修工作都應由具有相關資格的人員來完成。



This symbol indicates the presence of electric shock hazards. The area contains no user or field-serviceable parts. Do not open for any reason.



WARNING

To reduce risk of injury from electric shock hazards, do not open this enclosure.

此符號表明存在觸電的危險。在這一區域內沒有用戶可以現場維修的部件。一定不要打開。警告：為了減少觸電造成人身傷害的危險，請不要打開此外殼。



This symbol on an RJ-45 receptacle indicates a Network Interface Connection.



WARNING

To reduce risk of electric shock, fire, or damage to the equipment, do not plug telephone or telecommunications connectors into this receptacle.

RJ-45 插孔上的該符號指示網絡接口連接。

警告：為了減少觸電、火災或設備損壞的危險，不要將電話或電信連接設備插入此插孔。



This symbol indicates the presence of a hot surface or hot component. If this surface is contacted, the potential for injury exists.



WARNING

To reduce the risk of injury from a hot component, allow the surface to cool before touching.

此符號表明表面或組件過熱。如果觸摸此表面，可能會造成人身傷害。警告：為了減少因組件過熱而造成人身傷害的危險，應等到表面降溫後再觸摸。



This symbol indicates the presence of a moving fan blade. If the spinning blades are contacted, the potential for injury exists.



WARNING

Hazardous moving parts. Keep away from moving fan blades. To reduce the risk of injury from a hot component, allow the surface to cool before touching.

此符號表明存在運動風扇葉片的危險。如果觸摸旋轉葉片，可能會造成人身傷害。警告：危險的運動部件。請遠離運動風扇刀片。為減少被高溫組件燙傷的危險，應在表面冷卻之後再接觸。

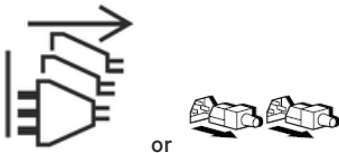

These symbols on power supplies or systems indicate that the equipment is supplied by multiple sources of power.

**WARNING**

To reduce the risk of injury from electric shock, remove all power cords to completely disconnect power from the system.

電源或系統上的這些符號表明設備由多個電源供電。

警告：為了減少觸電造成人身傷害的危險，應拔下所有電源線插頭，完全斷開系統的電源。



Weight in kg.

Weight in lb.

This symbol indicates that the component exceeds the recommended weight for one individual to handle safely.

**WARNING**

To reduce the risk of personal injury or damage to the equipment, observe local occupational health and safety requirements and guidelines for manual material handling.

此符號表明組件的重量超出了建議值，一個人無法安全取放。

警告：為了減少人身傷害或設備損壞的危險，應遵守當地有關人工取放物品的職業保健與安全規定及準則。



A discharge of static electricity from a finger or other conductor may damage system boards or other static-sensitive devices. To prevent damage, observe antistatic precautions.

手指或其它導體所釋放的靜電可能損壞主板或其它對靜電敏感的設備。為防止發生損壞，請遵守防靜電預防措施。



These symbols appearing together indicate that the product may have high touch current and that a reliable earth ground must be in place before connecting the equipment.

**WARNING**

Risk of electric shock due to high touch current. Connect to earth before connecting to supply.



This symbol indicates the presence of a laser device in the product that may exceed Class 1 limits. Refer to the product documentation for more information.

此符號表明在可能會超出 1 類限制的產品中存在激光設備。有關詳細信息，請參閱產品文檔。



This symbol indicates the presence of moving parts inside the product that may present a pinch point if improperly contacted.



WARNING

Hazardous moving parts. Do not insert any tools or any part of your body into the product while it is operating or in any openings.



This symbol indicates the presence of coin cell battery.



WARNING

- **INGESTION HAZARD:** This product contains a button cell or coin battery.
- **DEATH** or serious injury can occur if ingested.
- A swallowed button cell or coin battery can cause Internal Chemical Burns in as little as 2 hours.
- **KEEP** new and used batteries **OUT OF REACH** of **CHILDREN**.
- Seek immediate medical attention if a battery is suspected to be swallowed or inserted inside any part of the body.

Rack warnings and cautions



WARNING

When all components are removed, the server weighs 11.05 kg (24.36 lb). When all components are installed, the server can weigh up to 17.25 kg (38.03 lb).

Before configuring your rack solution, be sure to check the rack manufacturer weight limits and specifications. Failure to do so can result in physical injury or damage to the equipment and the facility.



WARNING

The server is heavy. To reduce the risk of personal injury or damage to the equipment, do the following:

- Observe local occupational health and safety requirements and guidelines for manual material handling.
- Get help to lift and stabilize the product during installation or removal, especially when the product is not fastened to the rails. The server weighs more than 11.05 kg (24.36 lb), so at least two people must lift the server into the rack together. An additional person may be required to help align the server if the server is installed higher than chest level.
- Use caution when installing the server in or removing the server from the rack.
- Adequately stabilized the rack before extending a component outside the rack. Extend only one component at a time. A rack may become unstable if more than one component is extended.
- Do not stack anything on top of rail-mounted component or use it as a work surface when extended from the rack.

**WARNING**

To reduce the risk of personal injury or damage to the equipment, be sure that:

- The rack has anti-tip measures in place. Such measures include floor-bolting, anti-tip feet, ballast, or a combination as specified by the rack manufacturer and applicable codes.
- The leveling jacks (feet) are extended to the floor.
- The full weight of the rack rests on the leveling jacks (feet).
- The stabilizing feet are attached to the rack if it is a single-rack installation.
- The racks are coupled together in multiple rack installations.

**WARNING**

To reduce the risk of personal injury or equipment damage when unloading a rack:

- At least two people are needed to safely unload the rack from the pallet. An empty 42U rack can weigh as much as 115 kg (253 lb), can stand more than 2.1 m (7 ft) tall, and might become unstable when being moved on its casters.
- Never stand in front of the rack when it is rolling down the ramp from the pallet. Always handle the rack from both sides.

**CAUTION**

Always plan the rack installation so that the heaviest item is on the bottom of the rack. Install the heaviest item first, and continue to populate the rack from the bottom to the top.

**CAUTION**

Before installing the server in a rack, be sure to properly scope the limitations of the rack. Before proceeding with the installation, consider the following:

- You must fully understand the static and dynamic load carrying capacity of the rack and be sure that it can accommodate the weight of the server.
- Be sure sufficient clearance exists for cabling, installation and removal of the server, and movement of the rack doors.

Server warnings and cautions

**WARNING**

To reduce the risk of personal injury, electric shock, or damage to the equipment, disconnect the power cord to remove power from the server. Pressing the Power On/Standby button does not shut off system power completely. Portions of the power supply and some internal circuitry remain active until AC power is removed.

**WARNING**

To reduce the risk of personal injury from hot surfaces, allow the drives and the internal system components to cool before touching them.



WARNING

To reduce the risk of fire or burns after removing the energy pack:

- Do not disassemble, crush, or puncture the energy pack.
- Do not short external contacts.
- Do not dispose of the energy pack in fire or water.
- Do not expose the energy pack to low air pressure as it might lead to explosion or leakage of flammable liquid or gas.
- Do not expose the energy pack to temperatures higher than 60°C (140°F).

After power is disconnected, battery voltage might still be present for 1s to 160s.



CAUTION

Protect the server from power fluctuations and temporary interruptions with a regulating UPS. This device protects the hardware from damage caused by power surges and voltage spikes and keeps the server in operation during a power failure.



CAUTION

To prevent damage to electrical components, properly ground the server before beginning any installation, removal, or replacement procedure. Improper grounding can cause electrostatic discharge.



CAUTION

To avoid data loss, Hewlett Packard Enterprise recommends that you back up all server data before installing or removing a hardware option, or performing a server maintenance or troubleshooting procedure.



CAUTION

Do not operate the server for long periods with the access panel open or removed. Operating the server in this manner results in improper airflow and improper cooling that can lead to thermal damage.

Preparation procedures

Prerequisites

Before powering down the server for an upgrade, maintenance, or service procedure, perform a backup of critical server data.

About this task

To access components and perform certain upgrade, maintenance, or service procedure, you must perform one or more of the procedures described in this section.

Subtopics

Server data backup

Power up the server

Power down the server

Release the cable management arm

Extend the server out of the rack

Remove the front bezel

Remove the access panel

Remove the middle cover

Remove the energy pack retention latch

Remove the fan wall

Remove the riser cage

Remove the server from the rack

Server data backup

To avoid data loss, make sure to back up all server data before installing or removing a hardware option, performing a server maintenance, or a troubleshooting procedure.

Server data in this context refers to information that may be required to return the system to a normal operating environment after completing a hardware maintenance or troubleshooting procedure. This information may include:

- User data files
- User account names and passwords
- Application settings and passwords
- Component drivers and firmware
- TPM recovery key/password
- BIOS configuration settings—Use the backup and restore function in UEFI System Utilities. For more information, see the UEFI user guide (<https://www.hpe.com/support/hpeuefismutlities-quicklinks>).
 - Custom default system settings
 - Security passwords including those required for power-on and BIOS admin access, persistent memory, and Server Configuration Lock (for HPE Trusted Supply Chain servers)
 - Server serial number and the product ID
- iLO-related data—Use the iLO backup and restore function. For more information, see the iLO user guide (<https://www.hpe.com/support/hpeilodocs-quicklinks>).
 - iLO license
 - Customer iLO user name, password, and DNS name
 - iLO configuration settings

Power up the server

Procedure

- Press the Power On/Standby button.
- Use the virtual power button through iLO 7.

Power down the server

Before powering down the server for any upgrade or maintenance procedures, perform a backup of critical server data and programs.



IMPORTANT

When the server is in standby mode, auxiliary power is still being provided to the system.

To power down the server, use one of the following methods:

- Press and release the Power On/Standby button.
This method activates a controlled shutdown of applications and the OS before the server enters standby mode. It can also activate a shutdown behavior governed by an OS configuration or policy.
- Press and hold the Power On/Standby button for more than 4 seconds to force the server to enter standby mode.
This method forces the server to enter standby mode without properly exiting applications and the OS. If an application stops responding, you can use this method to force a shutdown.
- Use a virtual power button selection through iLO 7.
This method initiates a controlled remote shutdown of applications and the OS before the server enters standby mode.

Before proceeding, verify that the server is in standby mode by observing that the system power LED is amber.

Release the cable management arm

Procedure

Release the cable management arm and swing away from the rack.

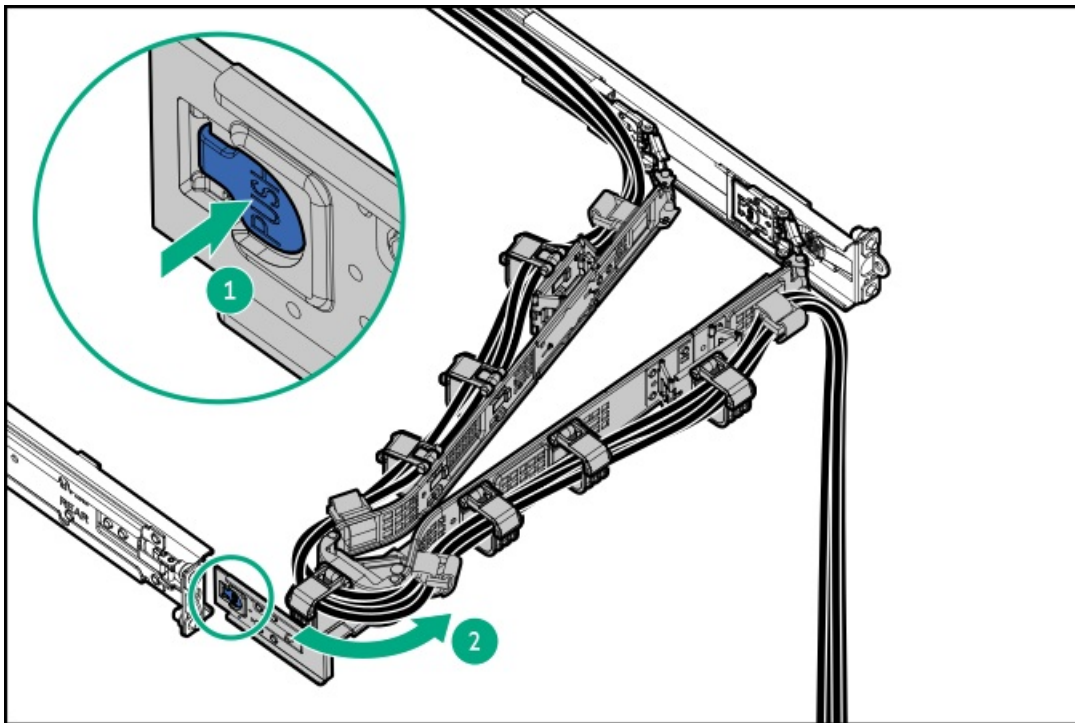

Extend the server out of the rack

Prerequisites

- Before you perform this procedure, review the [Rack warnings and cautions](#).
- T-25 Torx screwdriver—This tool is required if the shipping screws located inside the chassis ears are secured.

About this task



WARNING

To reduce the risk of personal injury, be careful when pressing the server rail-release latches. The inner rails could pinch your fingers.

Procedure

1. If needed, loosen the shipping screws, and then use the chassis ear latches to slide the server out of the rack until the rail-release latches are engaged.

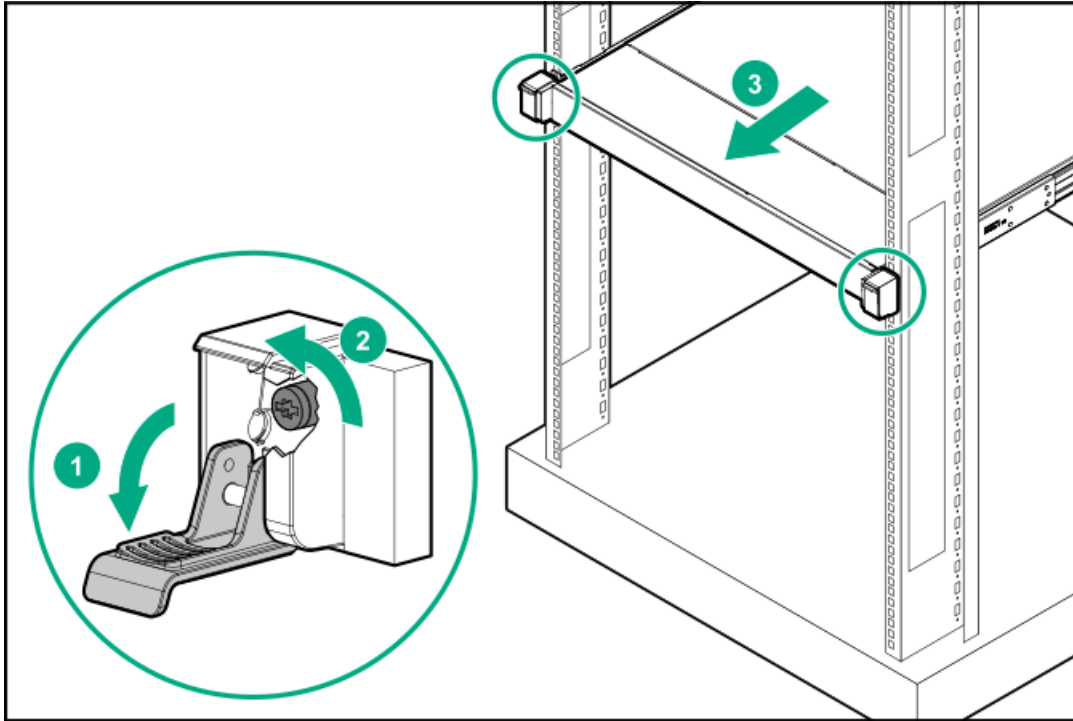

2. Press and hold the rear-end rail-release latches, and then slide the server out of the rack until it is fully extended.



WARNING

To reduce the risk of personal injury, be careful when pressing the server rail-release latches. The inner rails could pinch your fingers.

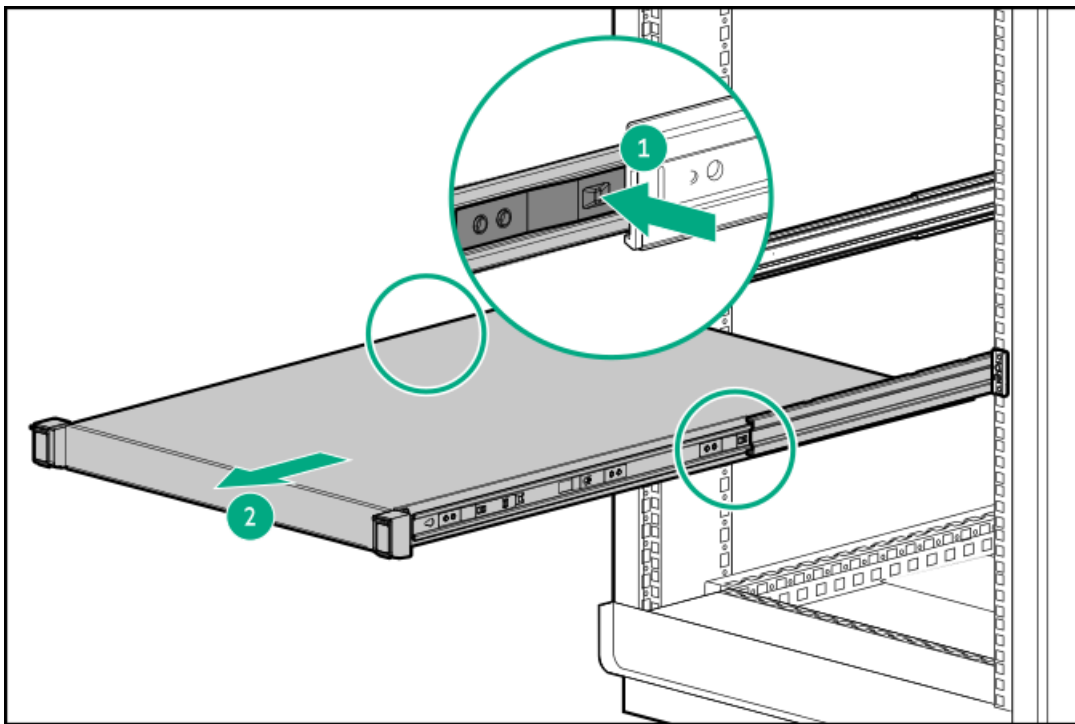

Remove the front bezel

About this task

If you are using the virtual power button in iLO to power the server on/off, you do not need to remove the front bezel. Remove the front bezel only if you need to access the front panel components.

Procedure

1. If installed, remove the Kensington security lock.

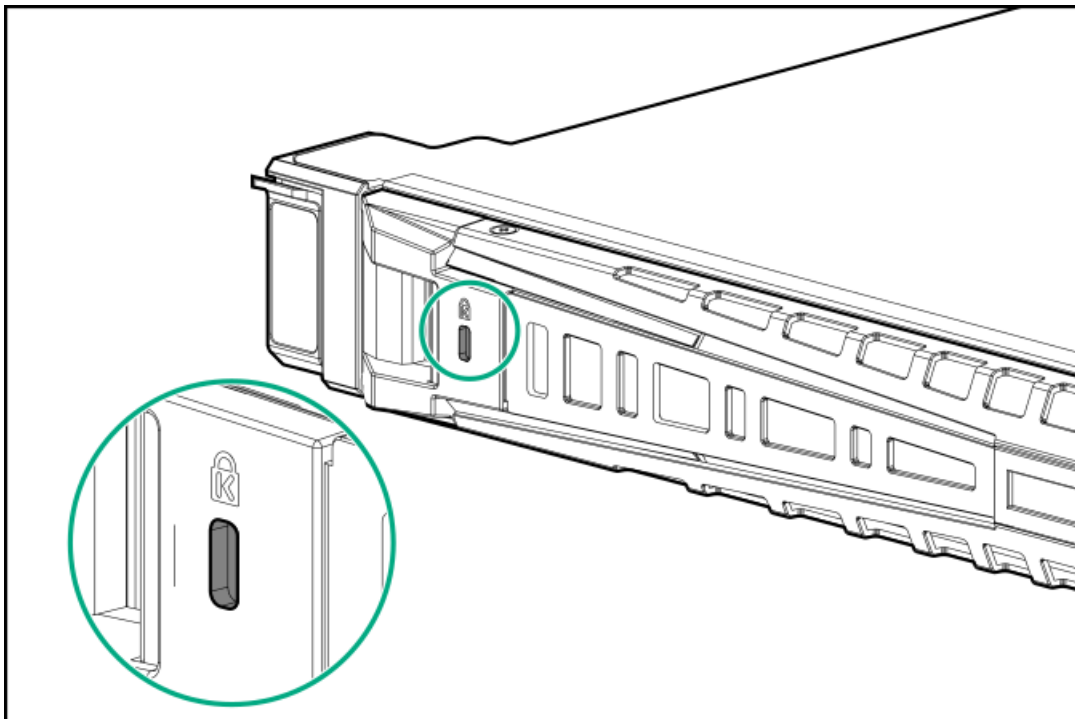

2. Press the bezel release latch, and then pivot the bezel open.
3. Release the right side of the bezel from the front panel.

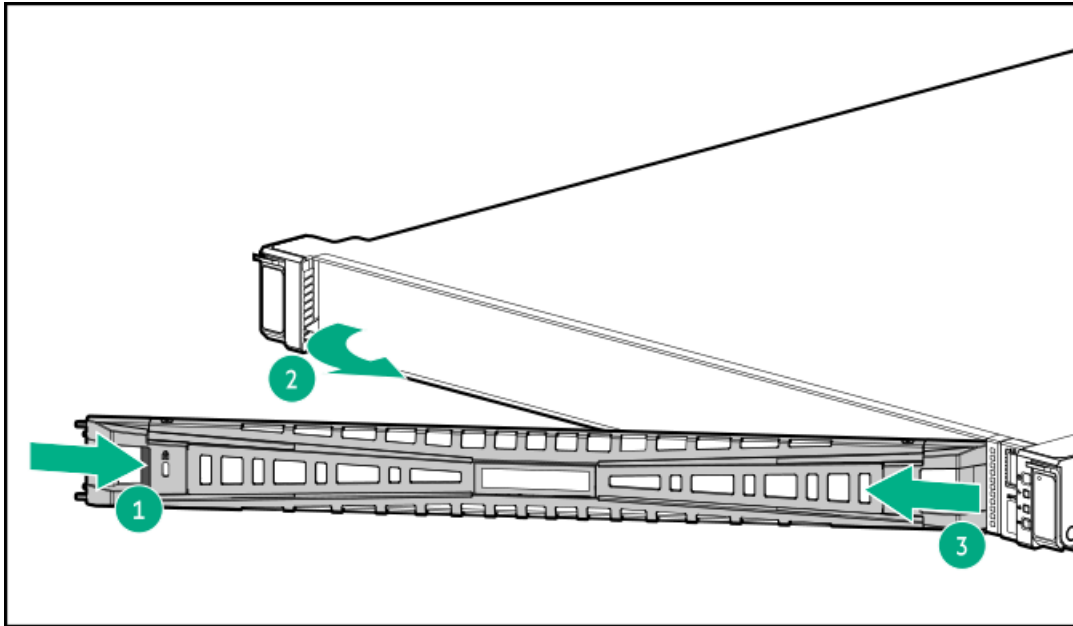

Remove the access panel

Prerequisites

Before you perform this procedure, make sure that you have a T-15 Torx screwdriver available.

About this task



WARNING

To reduce the risk of personal injury from hot surfaces, allow the drives and the internal system components to cool before touching them.



CAUTION

To prevent damage to electrical components, properly ground the server before beginning any installation, removal, or replacement procedure. Improper grounding can cause electrostatic discharge.



CAUTION

Do not operate the server for long periods with the access panel open or removed. Operating the server in this manner results in improper airflow and improper cooling that can lead to thermal damage.

Procedure

1. Power down the server.
2. Remove all power:
 - a. Disconnect each power cord from the power source.
 - b. Disconnect each power cord from the server.
3. Disconnect all peripheral cables from the server.

4. Do one of the following:
 - a. Extend the server from the rack.
 - b. Remove the server from the rack.
5. Remove the access panel:
 - a. If necessary, unlock the access panel latch.
 - b. To disengage the access panel from the chassis, press the release button and pull up the latch.
 - c. Lift the access panel.

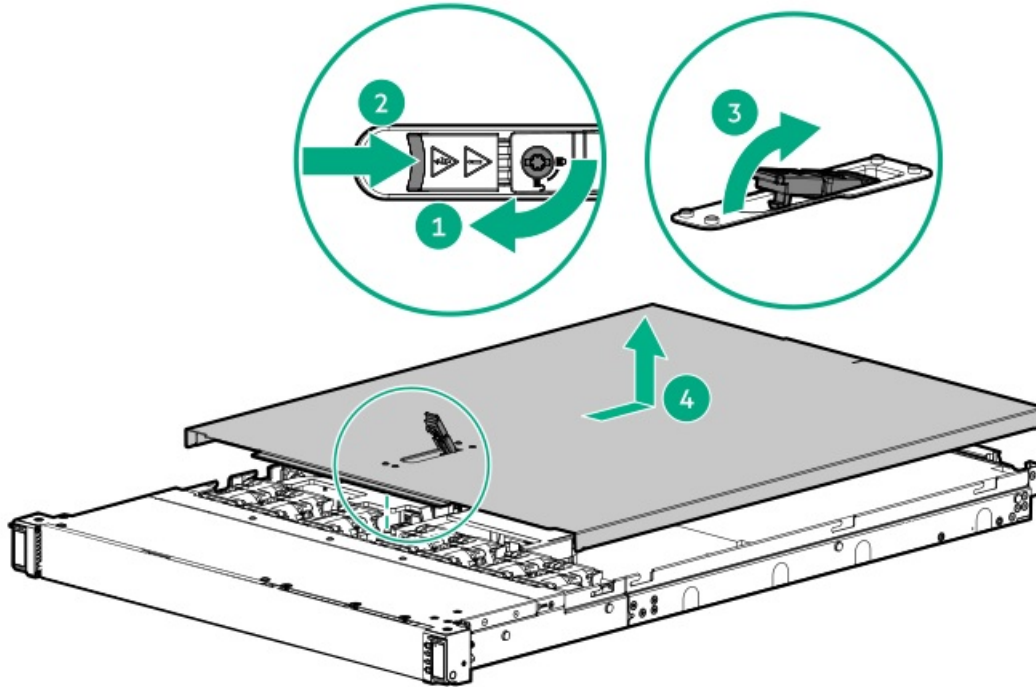

Remove the middle cover

Prerequisites

A T-10 Torx screwdriver is required to remove the middle cover from a GPU-optimized server.

About this task



CAUTION

For proper cooling, do not operate the server without the access panel, baffles, expansion slot covers, or blanks installed.



CAUTION

To prevent damage to electrical components, properly ground the server before beginning any installation, removal, or replacement procedure. Improper grounding can cause electrostatic discharge.

Procedure

1. Power down the server.

2. If installed, Release the cable management arm.
3. Remove all power:
 - a. Disconnect each power cord from the power source.
 - b. Disconnect each power cord from the server.
4. Disconnect all peripheral cables from the server.
5. Do one of the following:
 - a. Extend the server from the rack.
 - b. Remove the server from the rack.
6. Remove the access panel.
7. To remove the middle cover from the SFF, LFF, and the mixed drive configuration, take both sides of the middle cover and detach from the server.
 - LFF and mixed drive configuration

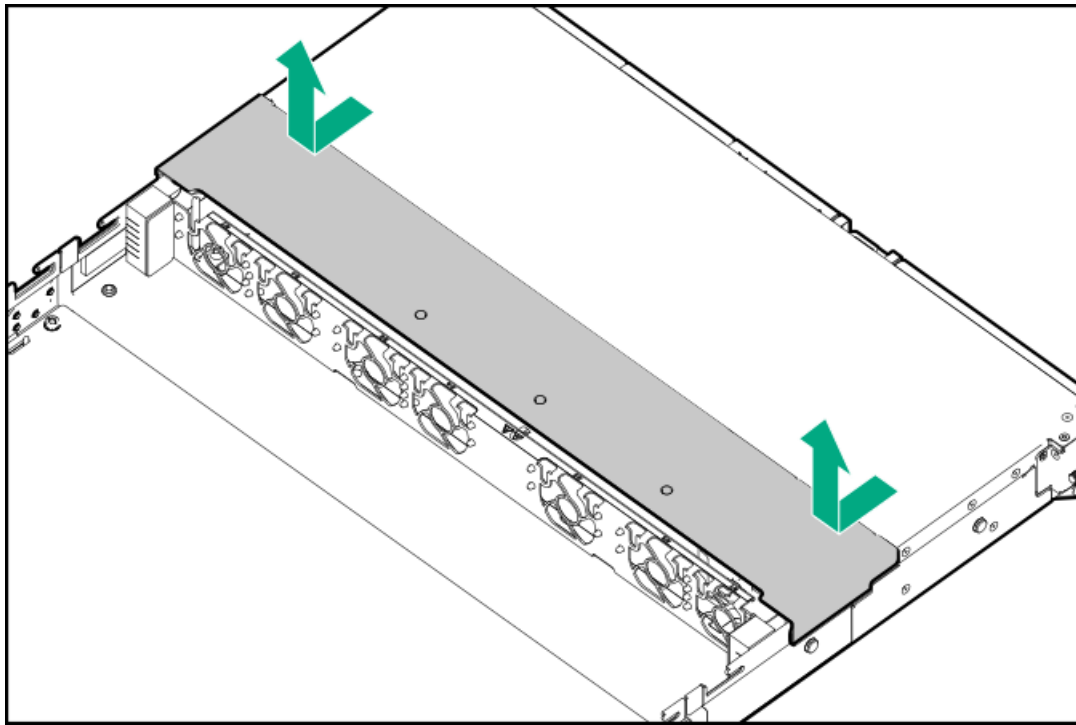

- SFF drive configuration

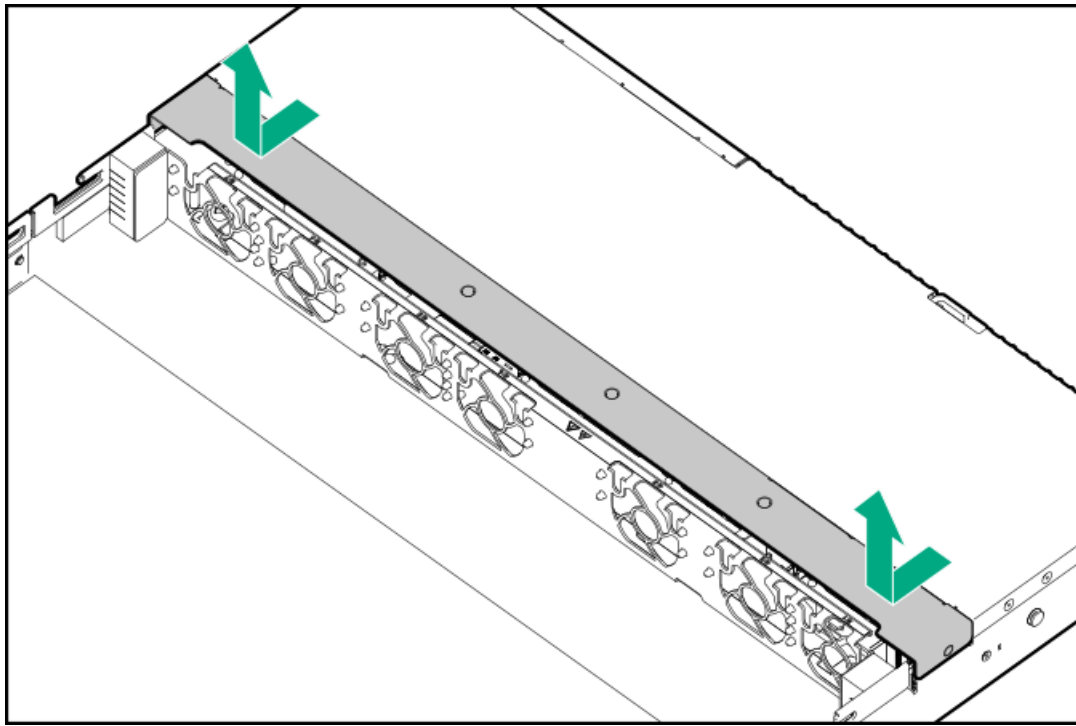

8. To remove the middle cover from the GPU-optimized configuration, do the following:

- a. Remove the screws.
- b. Take both sides of the middle cover and detach from the server.

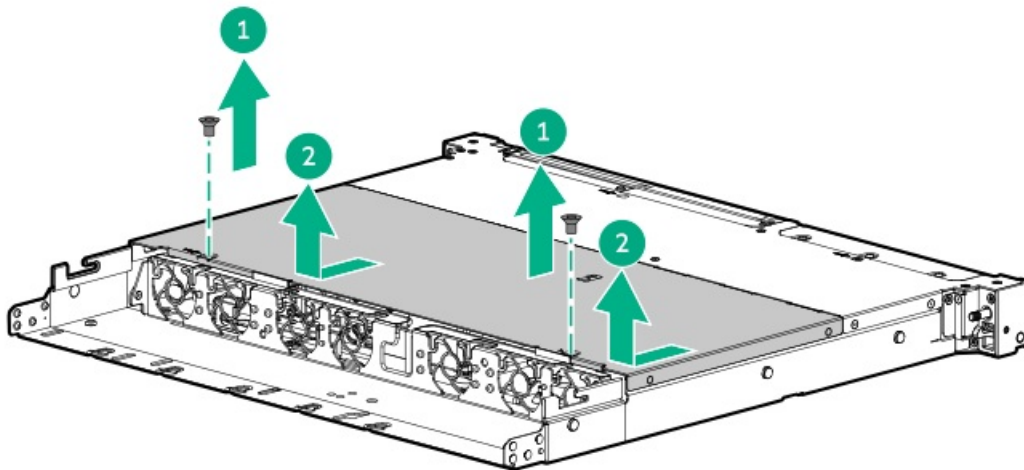

Remove the energy pack retention latch

About this task



CAUTION

A discharge of static electricity from a finger or other conductor might damage system boards or other static-sensitive devices. To prevent damage, observe [antistatic precautions](#).

Procedure

1. [Power down the server](#).

2. If installed, release the cable management arm.
3. Remove all power:
 - a. Disconnect each power cord from the power source.
 - b. Disconnect each power cord from the server.
4. Disconnect all peripheral cables from the server.
5. Remove the server from the rack.
6. Place the server on a flat, level work surface.
7. Remove the access panel.
8. Remove the middle cover.
9. Remove the front energy pack retention latch:
 - a. Pull up and hold the latch.
 - b. Push the latch to detach from the chassis.

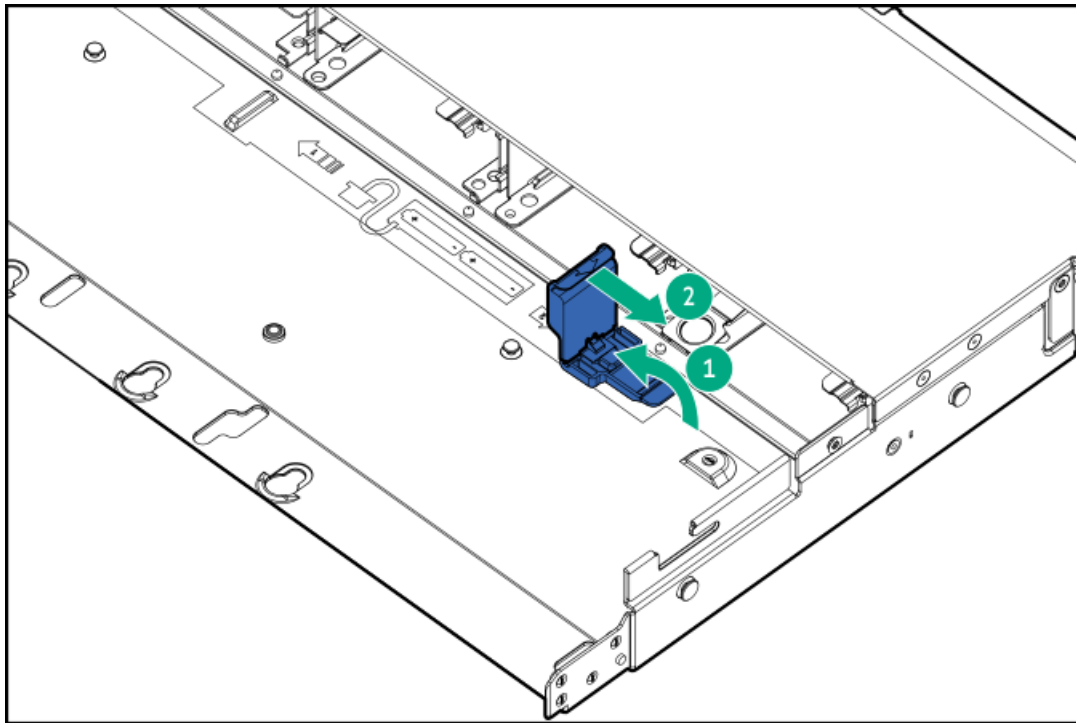

Remove the fan wall

Prerequisites

Before you perform this procedure, make sure that you have the following items available:

- T-15 Torx screwdriver—This is required to remove the fan wall from the SFF or 4 LFF drive configuration.
- T-10 Torx screwdriver—This is required to remove the fan wall from the 12 LFF drive or GPU-optimized configuration.

Procedure

1. Power down the server.
2. If installed, release the cable management arm.

3. Remove all power:
 - a. Disconnect each power cord from the power source.
 - b. Disconnect each power cord from the server.
4. Disconnect all peripheral cables from the server.
5. Remove the server from the rack.
6. Place the server on a flat, level work surface.
7. Remove the access panel.
8. Remove the middle cover.
9. Remove the fans.
10. Remove the fan wall.

Retain the screws and fan wall. These screws will be used to secure the fan wall after replacing or installing the internal component.

- SFF or 4 LFF drive configuration:

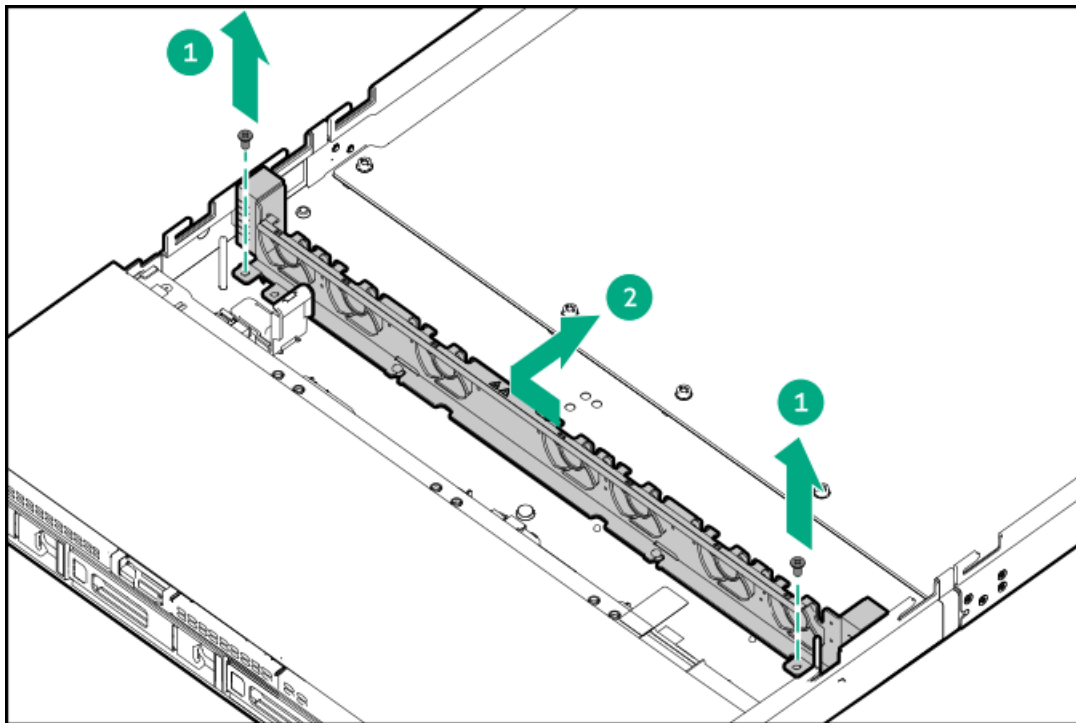

- 12 LFF drive configuration:

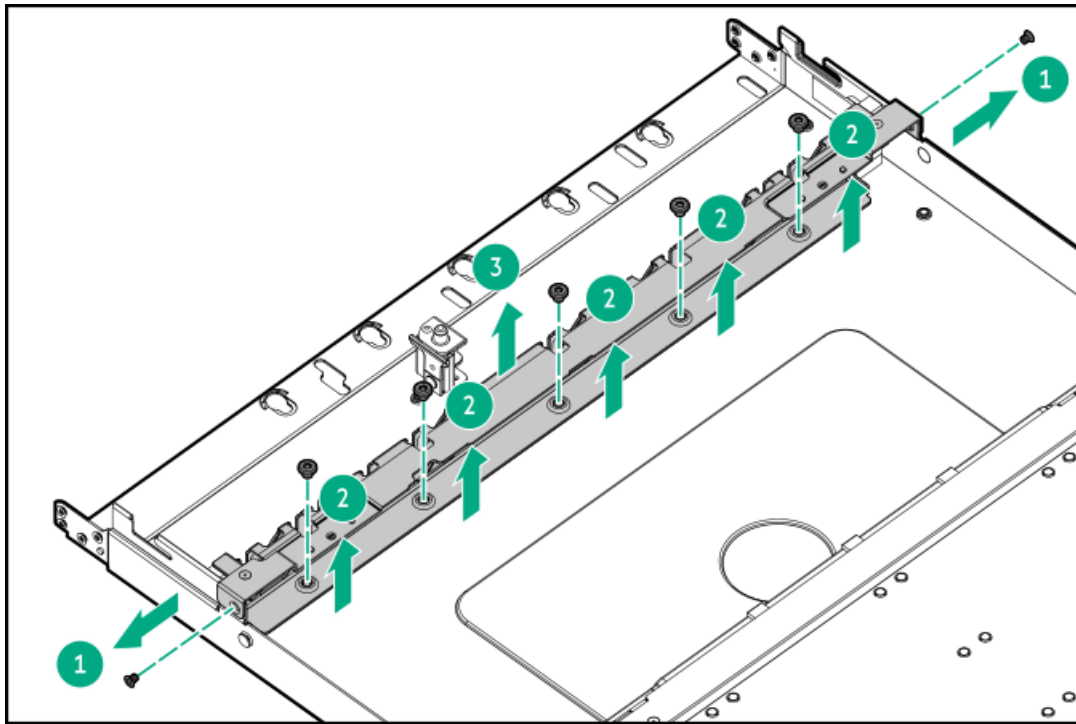

- GPU-optimized configuration:

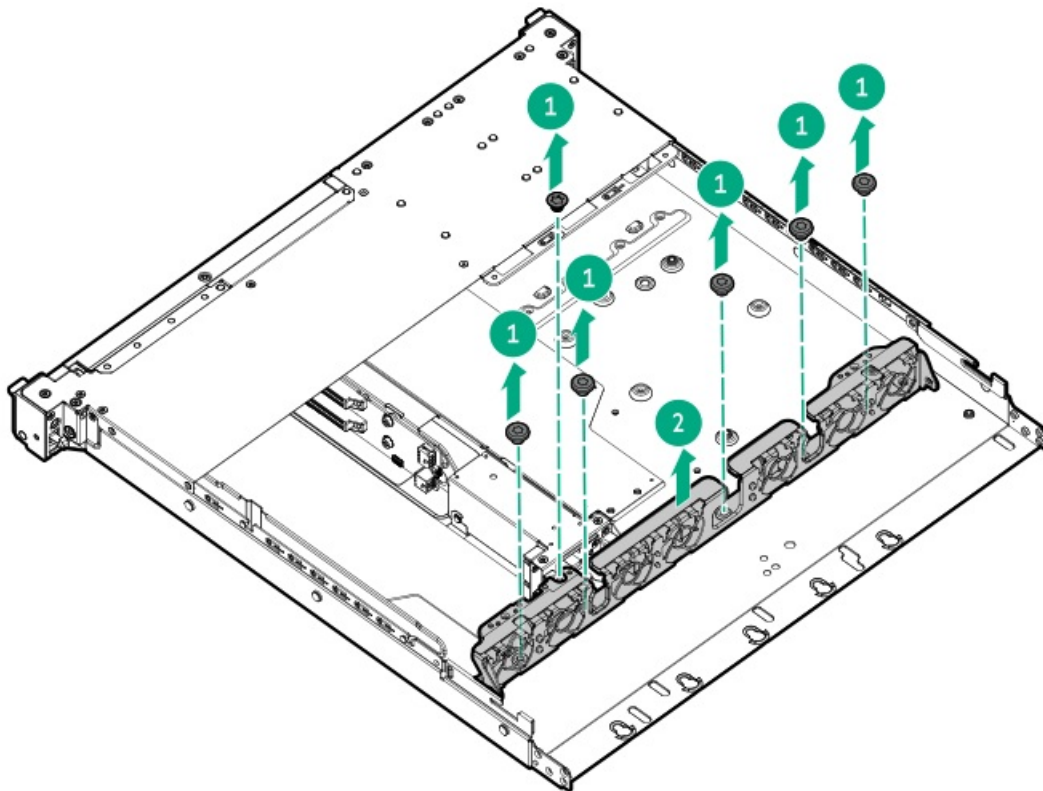

Remove the riser cage

Prerequisites

A T-10 Torx screwdriver is required to remove the GPU riser cage.

Procedure

1. Power down the server.
2. Release the cable management arm.
3. Remove all power:
 - a. Disconnect each power cord from the power source.
 - b. Disconnect each power cord from the server.
4. Disconnect all peripheral cables from the server.
5. Remove the server from the rack.
6. Place the server on a flat, level work surface.
7. Remove the access panel.
8. If an expansion card with internal cables is installed on the riser, disconnect the cables from the card.
9. To remove a full-height or low-profile riser cage, do the following:
 - a. Open the latch.
 - b. Remove the cage off of the system board.

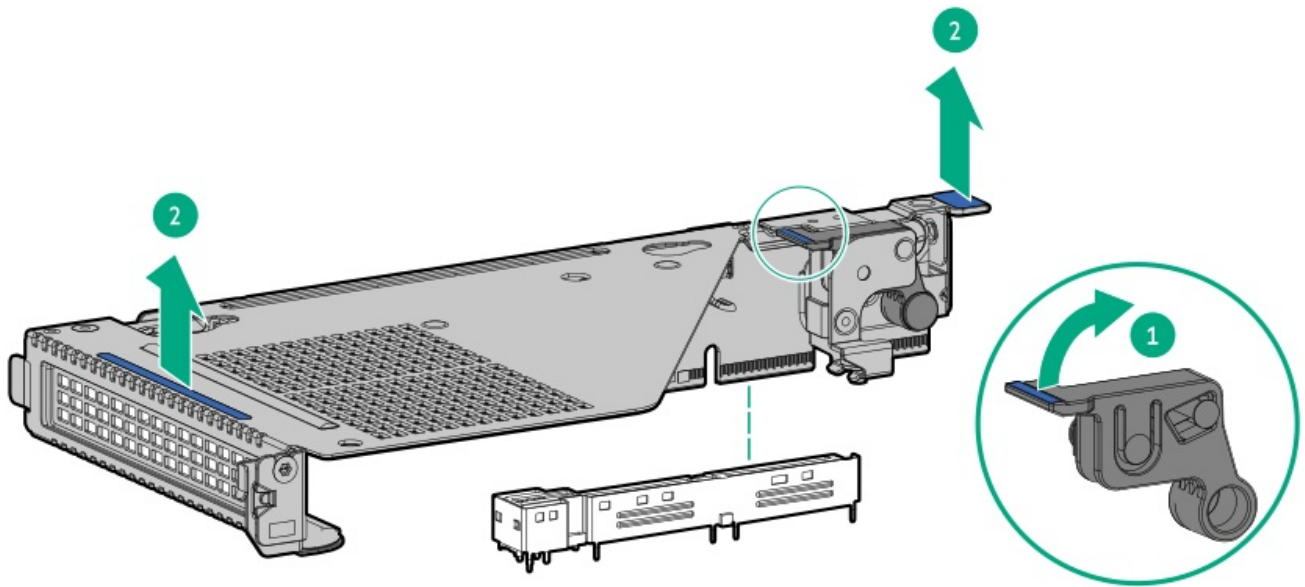

10. To remove the GPU riser cage, do the following:
 - a. Remove the two screws.
 - b. Push the cage forward, and then slide it out.

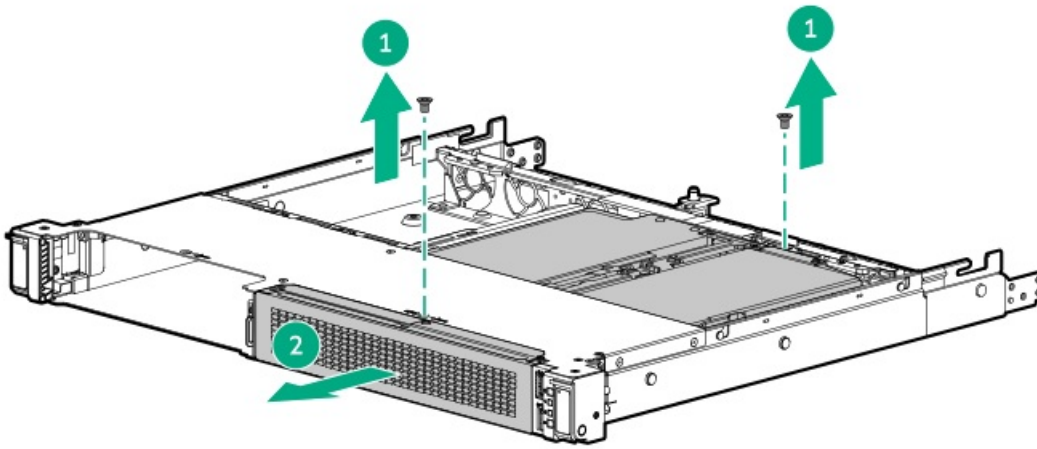

Remove the server from the rack

Prerequisites

- Get help to lift and stabilize the server during removal from the rack. **If the server is installed higher than chest level, additional two people might be required to help remove the server:** One person to support the server weight, and the other two to slide the server out of the rack.
- Before you perform this procedure, review the:
 - [Rack warnings and cautions](#)
 - [Server warnings and cautions](#)
- A fully populated server is heavy. Hewlett Packard Enterprise recommends removing the external chassis components before removing the server from the rack.

Procedure

1. [Power down the server.](#)
2. If installed, [release the cable management arm.](#)
3. Remove all power:
 - a. Disconnect each power cord from the power source.
 - b. Disconnect each power cord from the server.
4. Disconnect all peripheral cables from the server.
5. [Fully extend the server out of the rack.](#)
6. Slide the server completely out of the rack.

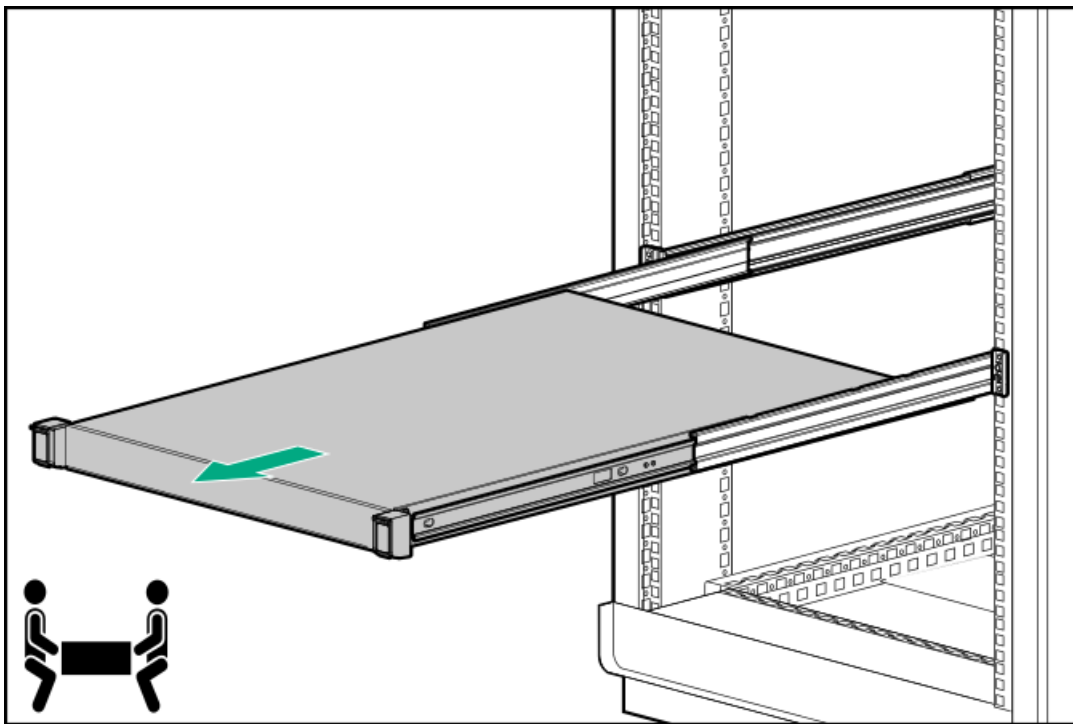

7. Place the server on a flat, level work surface.

Chassis ears replacement

Subtopics

[Removing and replacing the left chassis ear](#)

[Removing and replacing the right chassis ear and front I/O assembly](#)

Removing and replacing the left chassis ear

Prerequisites

Before you perform this procedure, make sure that you have a T-10 Torx screwdriver available.

Procedure

1. If installed, remove the front bezel.
2. Power down the server.
3. If installed, release the cable management arm.
4. Remove all power:
 - a. Disconnect each power cord from the power source.
 - b. Disconnect each power cord from the server.
5. Disconnect all peripheral cables from the server.
6. Remove the server from the rack.
7. Place the server on a flat, level work surface.

8. Remove the left chassis ear:

- a. Remove left chassis ear screws.

Retain the screws to secure the new left chassis ear spare.

- b. Detach the left chassis ear.

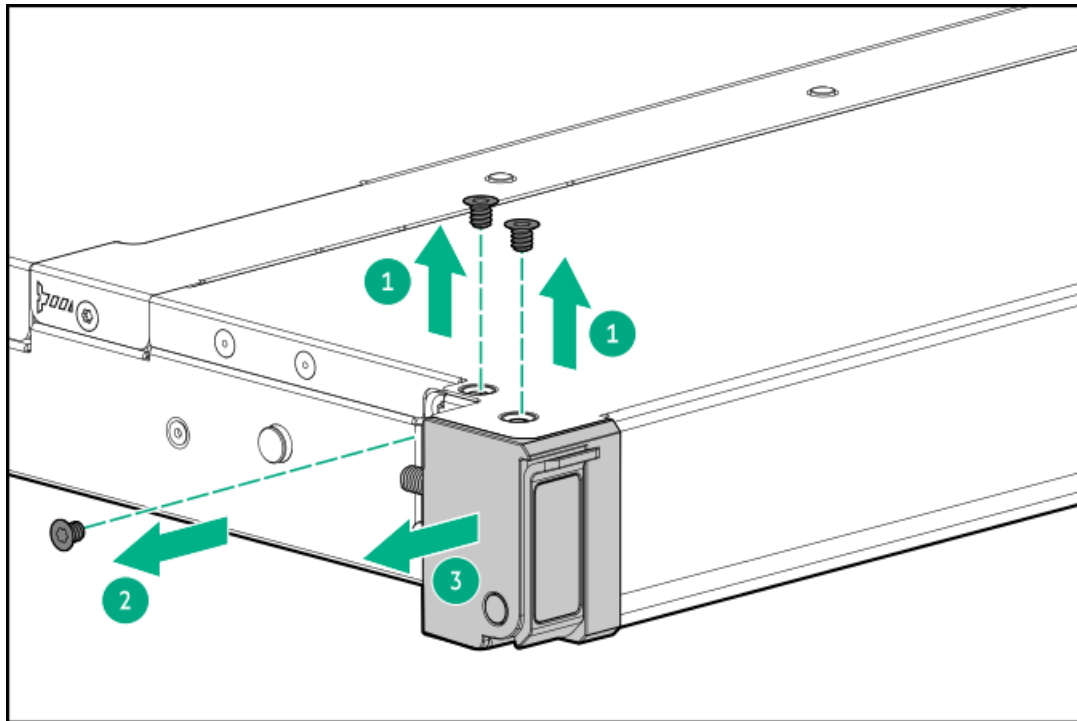

Results

The removal procedure is complete. To replace the component, reverse this procedure.

Removing and replacing the right chassis ear and front I/O assembly

Prerequisites

Before you perform this procedure, make sure that you have a T-10 Torx screwdriver available.

Procedure

1. If installed, remove the front bezel.
2. Power down the server.
3. If installed, release the cable management arm.
4. Remove all power:
 - a. Disconnect each power cord from the power source.
 - b. Disconnect each power cord from the server.
5. Disconnect all peripheral cables from the server.
6. Remove the server from the rack.
7. Place the server on a flat, level work surface.

8. Remove the access panel.
9. Disconnect the front I/O cable from the system board .

SFF drive configuration

10. Remove the right chassis ear:
 - a. Remove the screws.
 - b. Pull the right ear and front I/O port assembly simultaneously.

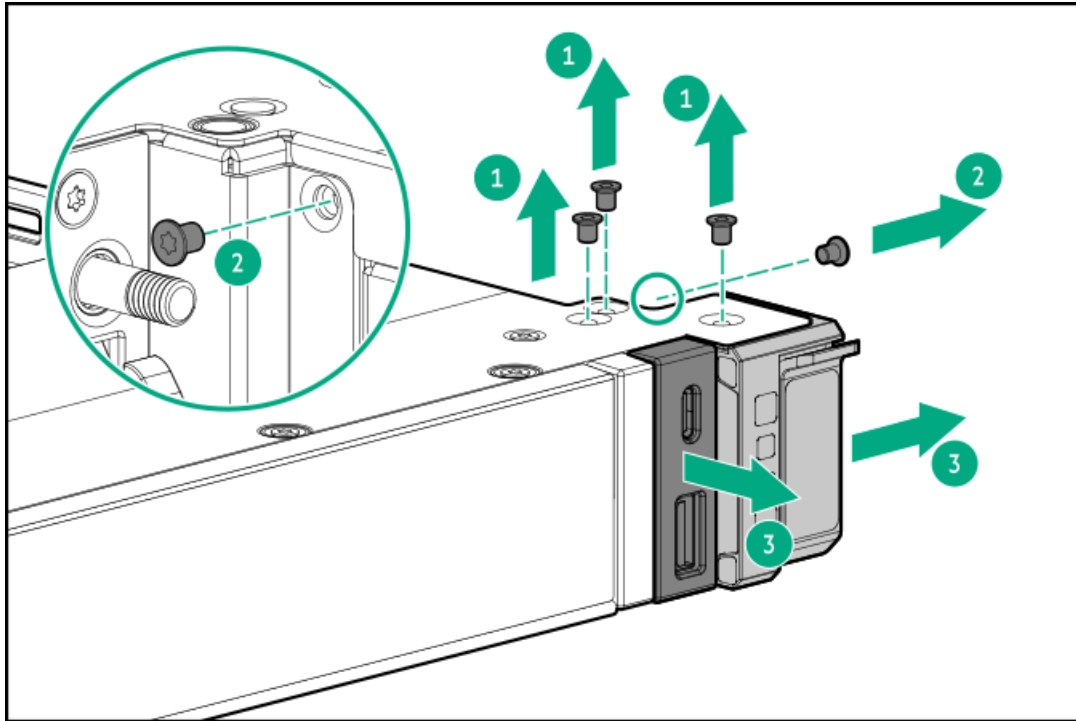

11. Remove the front I/O cable.

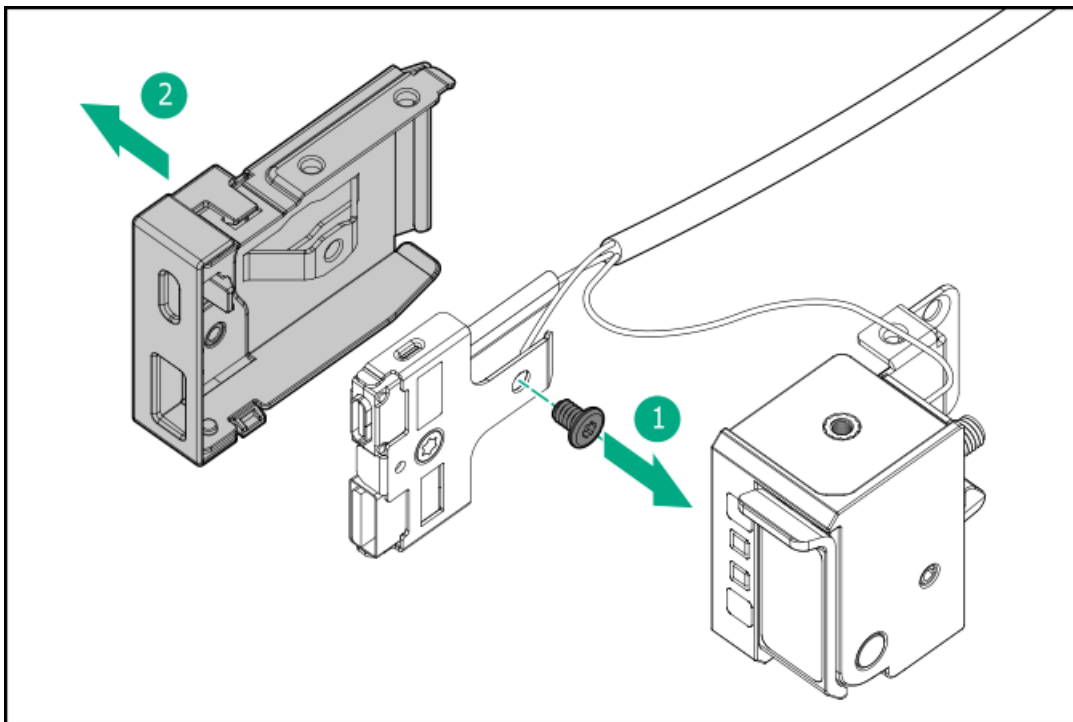

12. Remove the USB cable from the support bracket.



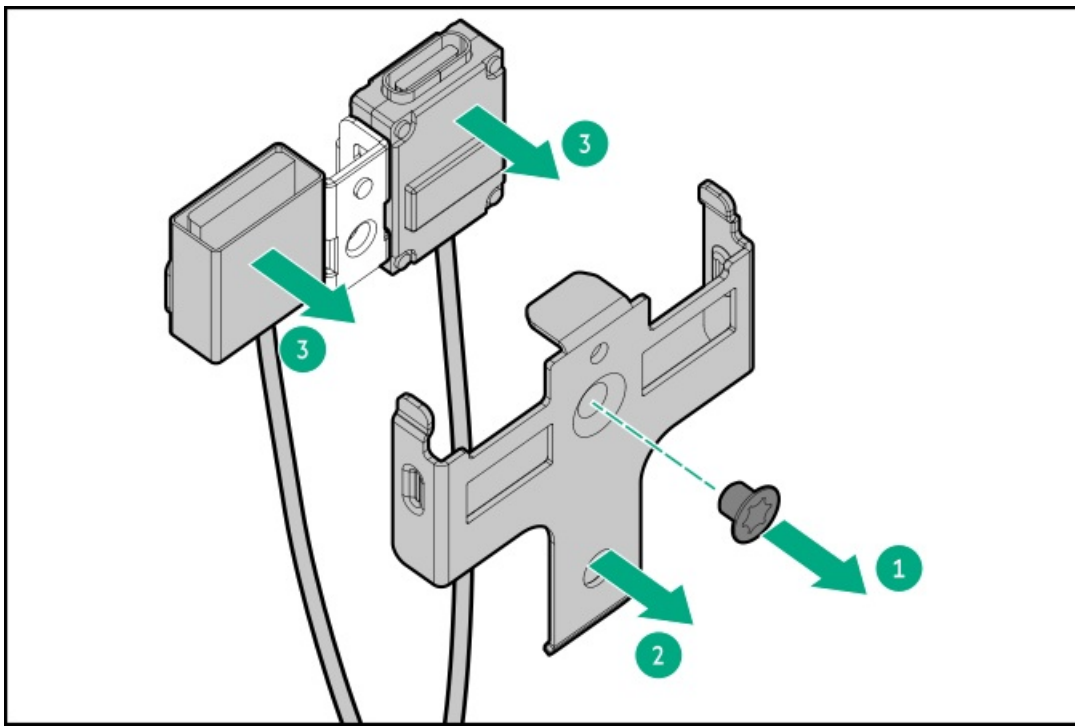

LFF drive configuration

13. Remove the right chassis ear:

- a. Remove the screws.
- b. Pull the right ear and front I/O port assembly simultaneously.

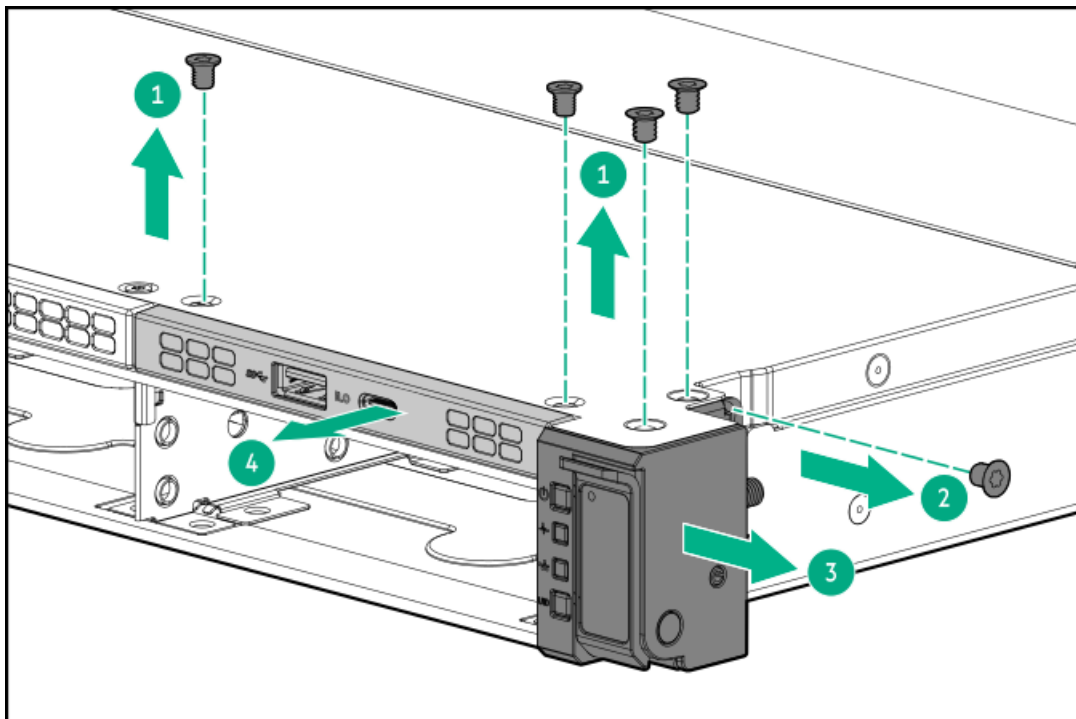

14. Remove the front I/O port assembly from the cage.



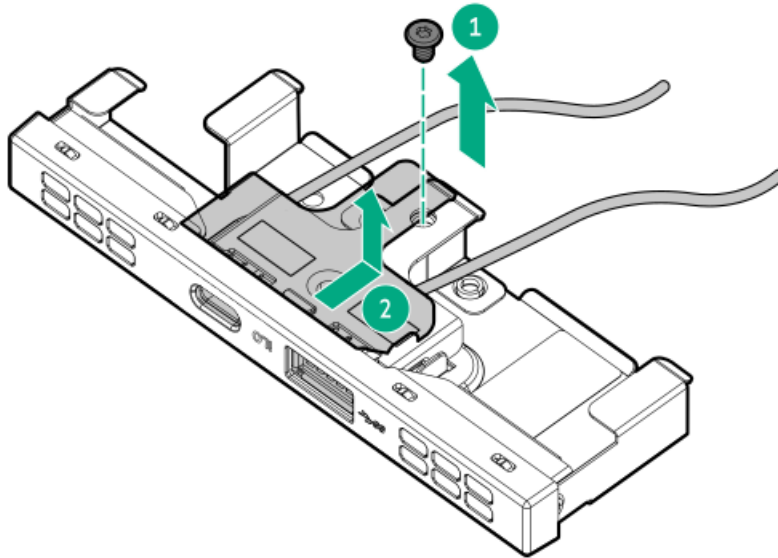

Results

The removal procedure is complete. To replace the component, reverse this procedure.

Removing and replacing the Systems Insight Display power module

Prerequisites

Before you perform this procedure, make sure that you have a T-10 Torx screwdriver available.

About this task

https://sketchfab.com/models/4e5ead76315d4abfad48b4228e7e9764/embed?ui_infos=0&ui_watermark=0&ui_help=0&ui_vr=0&ui_settings=0&ui_inspector=0&ui_hint=2&ui_color=01a982&ui_theme=dark&autostart=1&camera=0&



CAUTION

A discharge of static electricity from a finger or other conductor might damage system boards or other static-sensitive devices. To prevent damage, observe [antistatic precautions](#).

Procedure

1. If installed, [remove the front bezel](#).
2. [Power down the server](#).
3. Remove all power:
 - a. Disconnect each power cord from the power source.
 - b. Disconnect each power cord from the server.
4. Disconnect all peripheral cables from the server.
5. [Remove the server from the rack](#).
6. Place the server on a flat, level work surface.
7. [Remove the access panel](#).

8. Disconnect the cable from the system board.
9. Remove the SID.

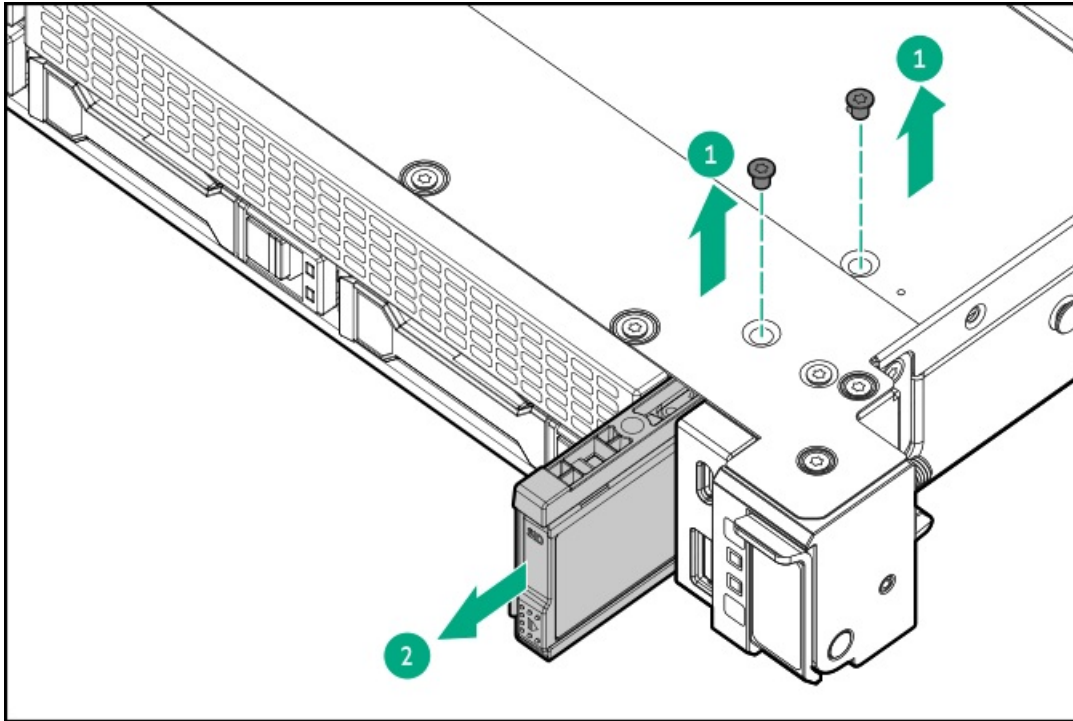

Results

To replace the component, reverse the removal procedure.

Removing and replacing a hot-plug drive

About this task

https://sketchfab.com/models/2d21243d5f194a5ea4d4c79657e77e74/embed?ui_infos=0&ui_watermark=0&ui_help=0&ui_vr=0&ui_settings=0&ui_inspector=0&ui_hint=2&ui_color=01a982&ui_theme=dark&autostart=1&camera=0&



CAUTION

A discharge of static electricity from a finger or other conductor might damage system boards or other static-sensitive devices. To prevent damage, observe [antistatic precautions](#).



CAUTION

To prevent improper cooling and thermal damage, do not operate the server unless all bays are populated with either a component or a blank.

Procedure

1. Back up all server data.
2. If installed, remove the front bezel.
3. Observe the drive LED status and determine if the drive can be removed.
 - LFF/SFF drive

- E3.S drive

4. If you are removing drives from the 12 LFF drive configuration, open the drive boxes.

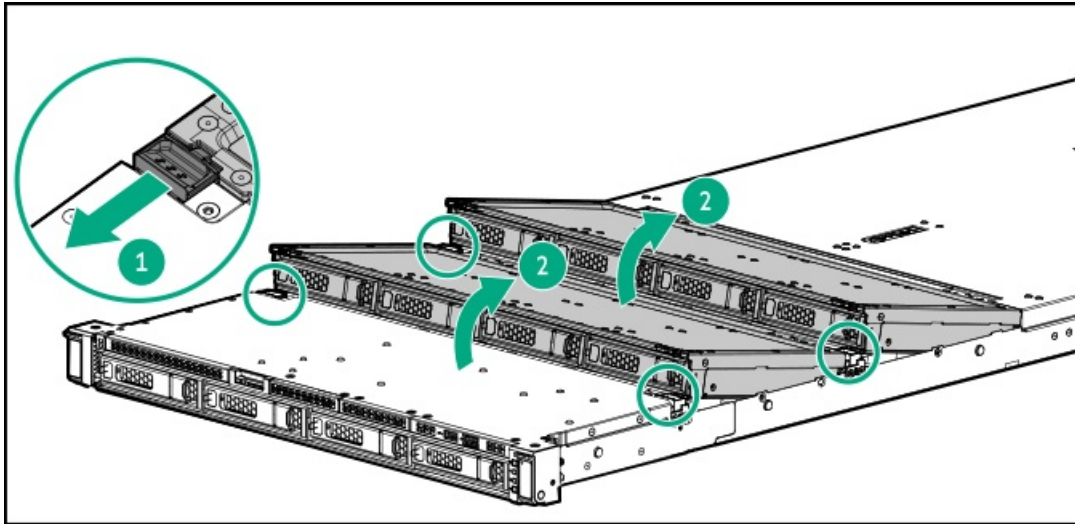

5. Remove the drive.

- LFF drive

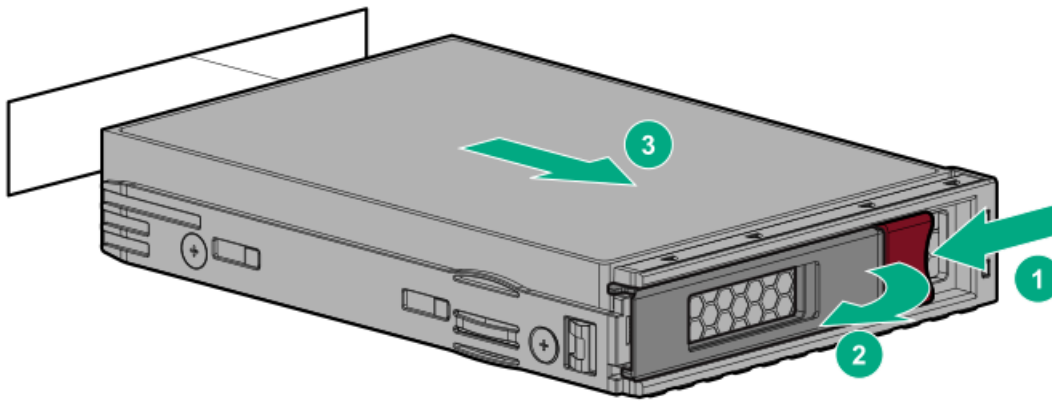

- SFF drive

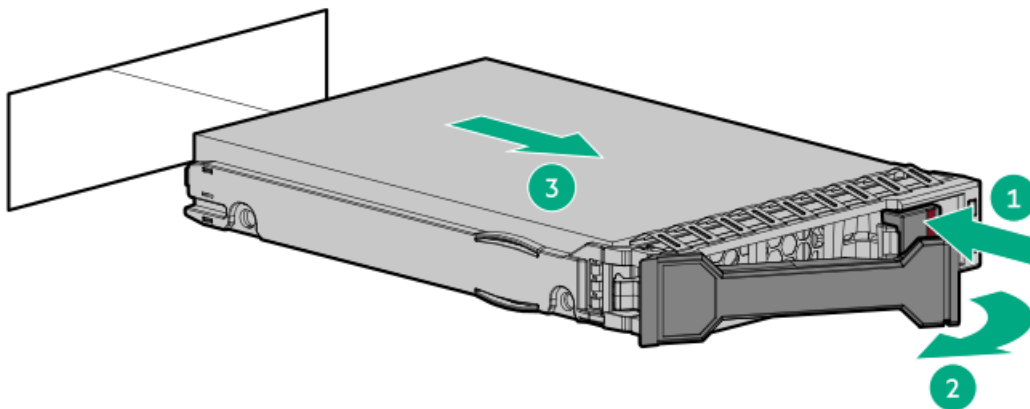

- E3.S drive



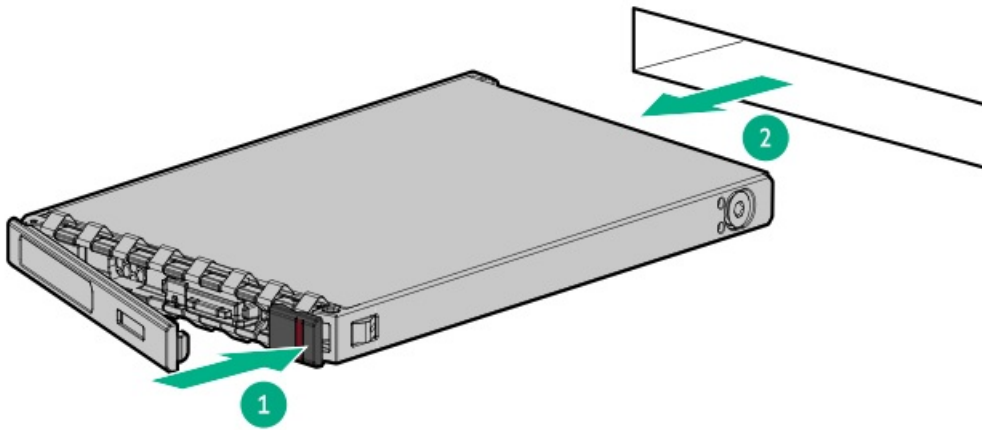

Results

The removal procedure is complete. To replace the component, reverse this procedure.

Removing and replacing a drive blank

About this task

https://sketchfab.com/models/ebfa72a6e53c4241b82df150ca59c962/embed?ui_infos=0&ui_watermark=0&ui_help=0&ui_vr=0&ui_settings=0&ui_inspector=0&ui_hint=2&ui_color=01a982&ui_theme=dark&autostart=1&camera=0&



CAUTION

To prevent improper cooling and thermal damage, do not operate the server unless all bays are populated with either a component or a blank.

Procedure

1. If installed, remove the front bezel.
2. Remove the drive blank.
 - LFF drive blank

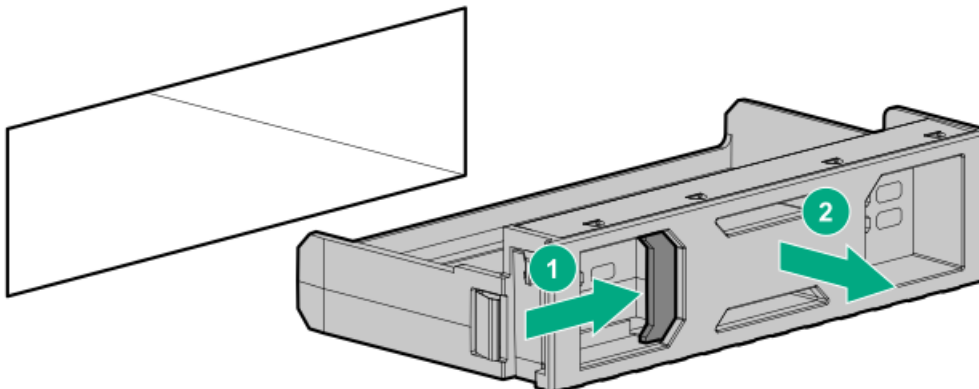

- SFF drive blank

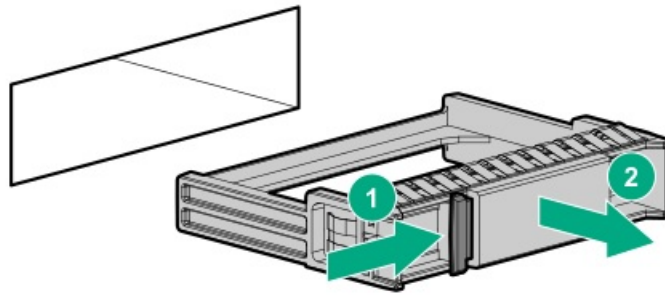

Results

The removal procedure is complete. To replace the component, reverse this procedure.

Removing and replacing the cable management arm

About this task



CAUTION

Support the CMA during the removal and replacement procedures. Do not allow the CMA to hang by its own weight during the procedure.

Procedure

1. Press and hold the release latch, and then remove the retention bracket from the mounting rail.

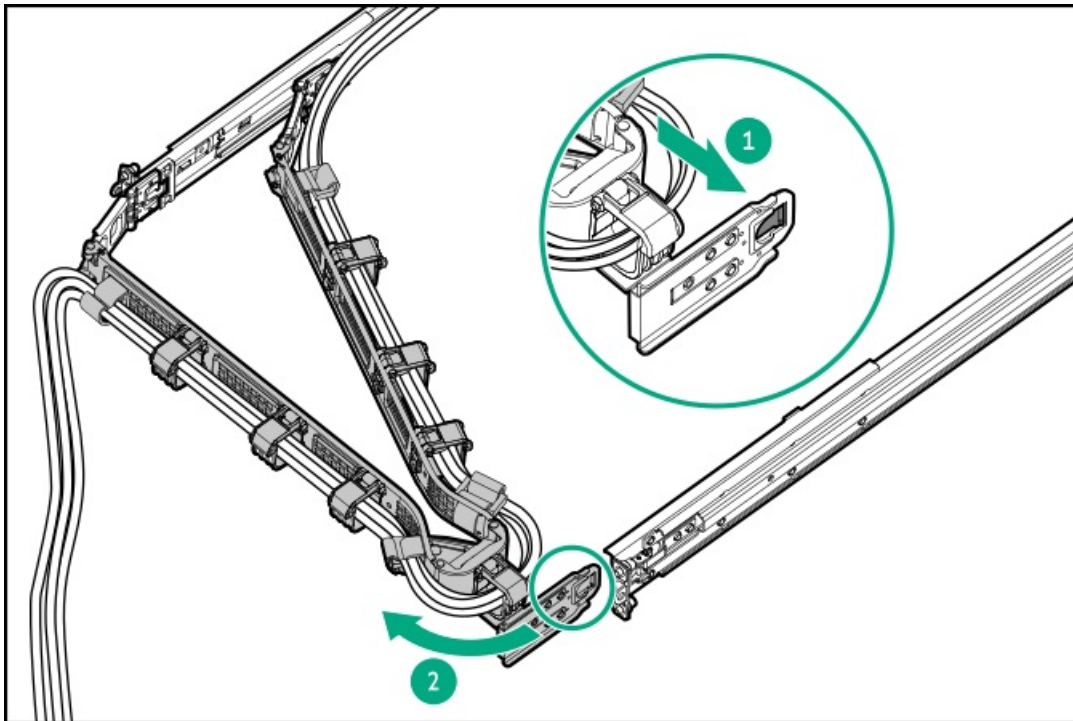

2. Open the cable clamps.

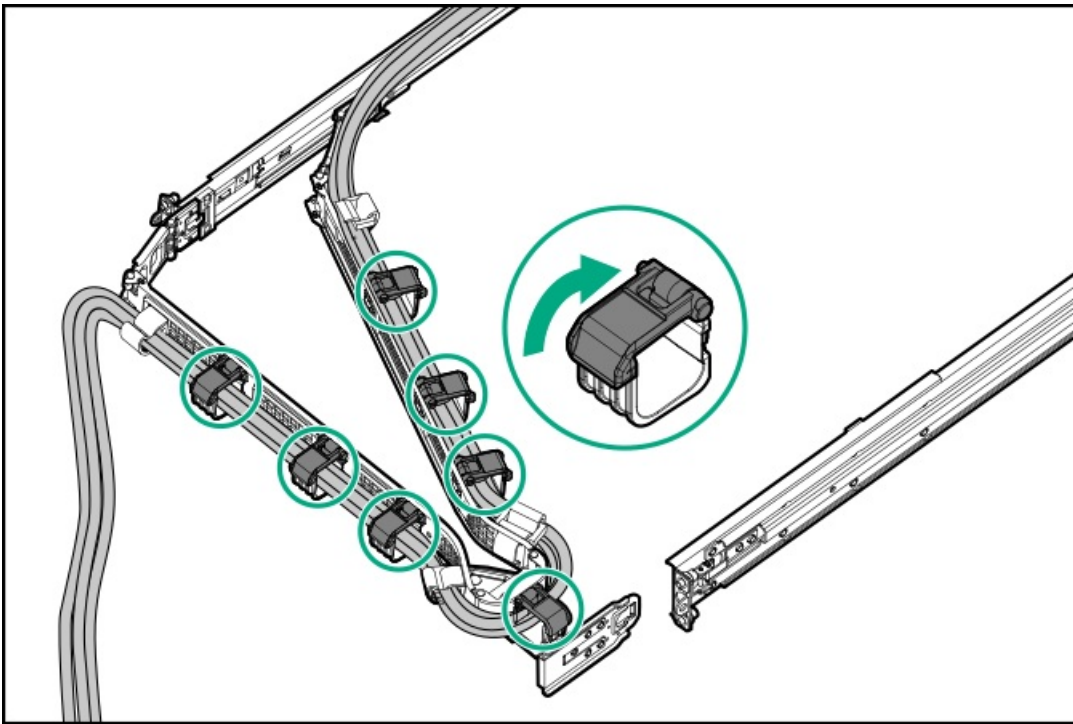

3. (Optional) If your CMA has cable straps, unwrap the straps.

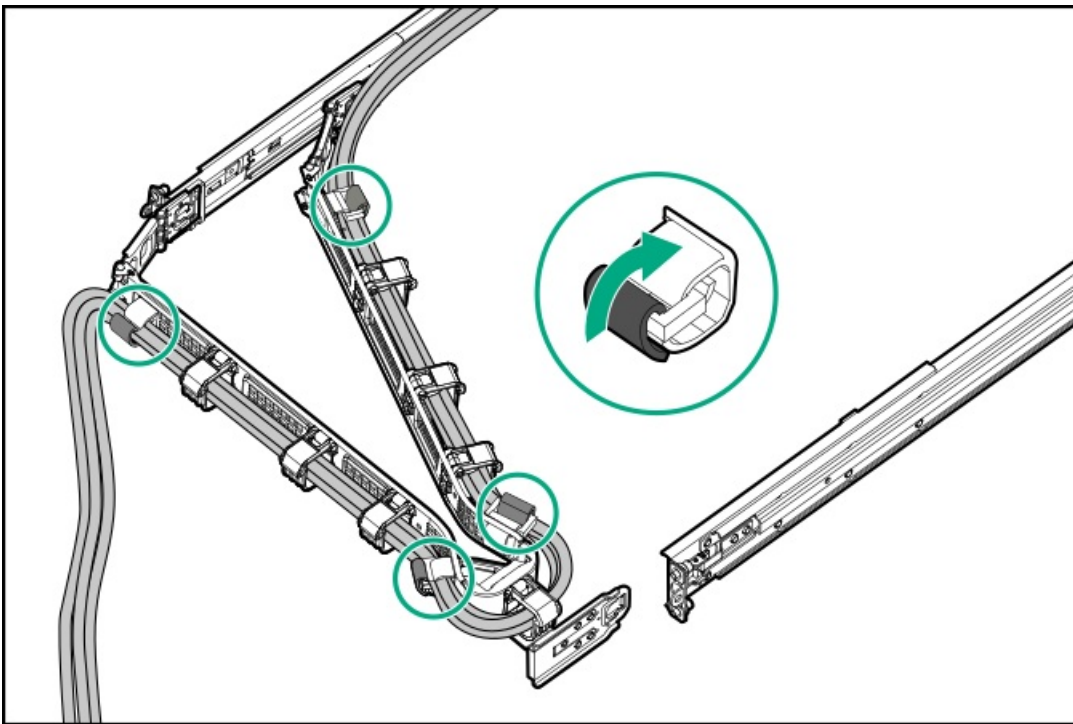

4. Remove the peripheral cables and power cords from the CMA.

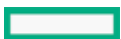

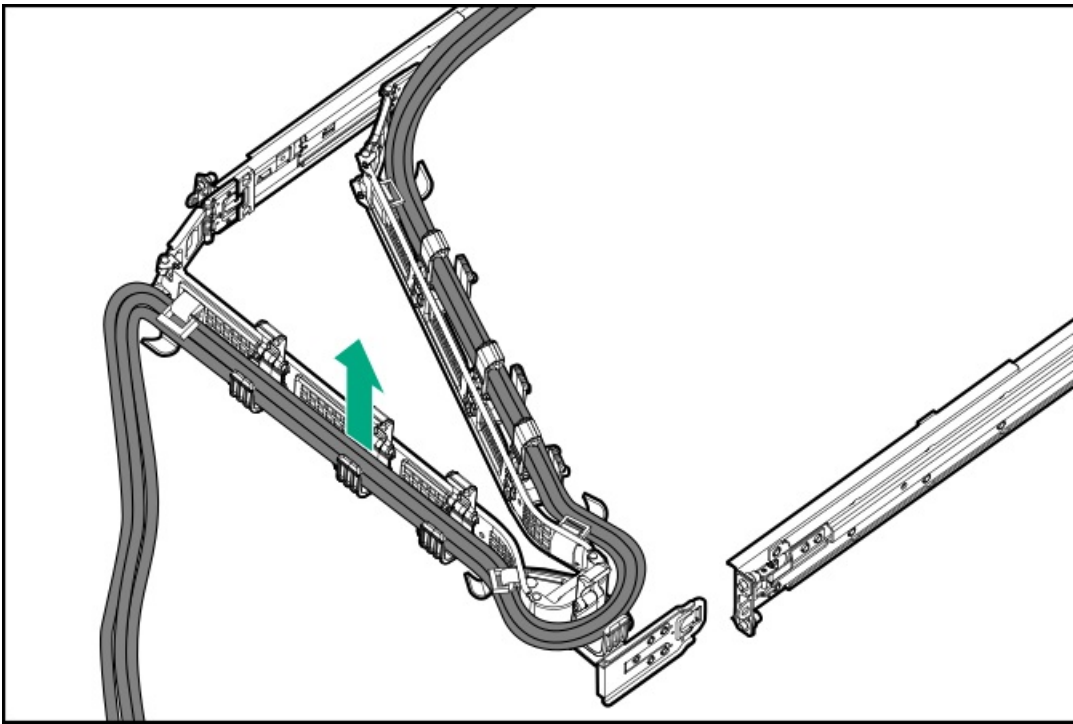

5. Press and hold the release latches, and then remove the outer tab and inner tab from the rails.

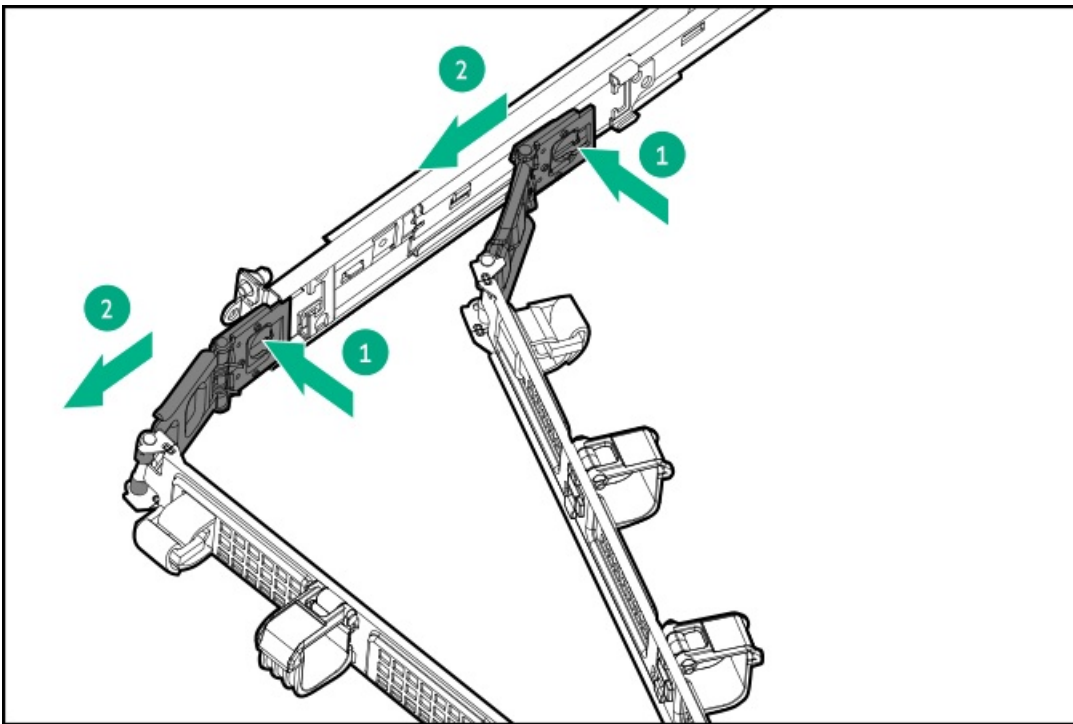

Results

The removal procedure is complete. To replace the component, reverse this procedure.

Removing and replacing the middle cover

About this task

Procedure

1. Power down the server.
2. If installed, release the cable management arm.
3. Remove all power:
 - a. Disconnect each power cord from the power source.
 - b. Disconnect each power cord from the server.
4. Disconnect all peripheral cables from the server.
5. Remove the server from the rack.
6. Place the server on a flat, level work surface.
7. Remove the access panel.
8. Take both sides of the middle cover, and then detach from the server.
 - LFF and mixed drive configuration

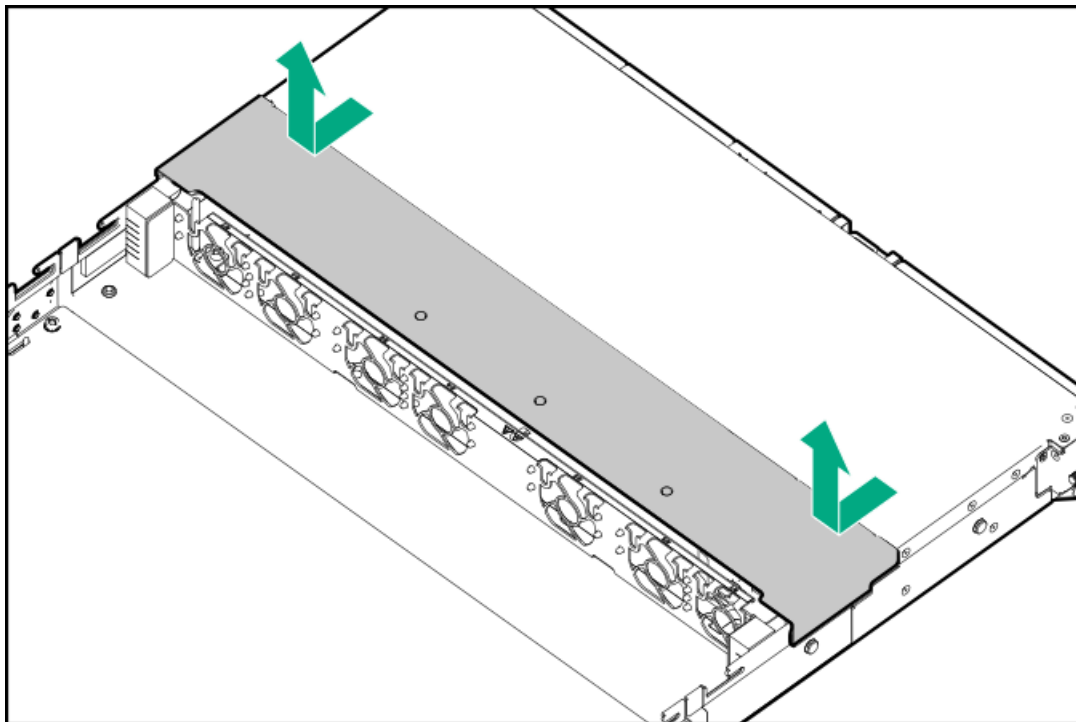

- SFF drive configuration

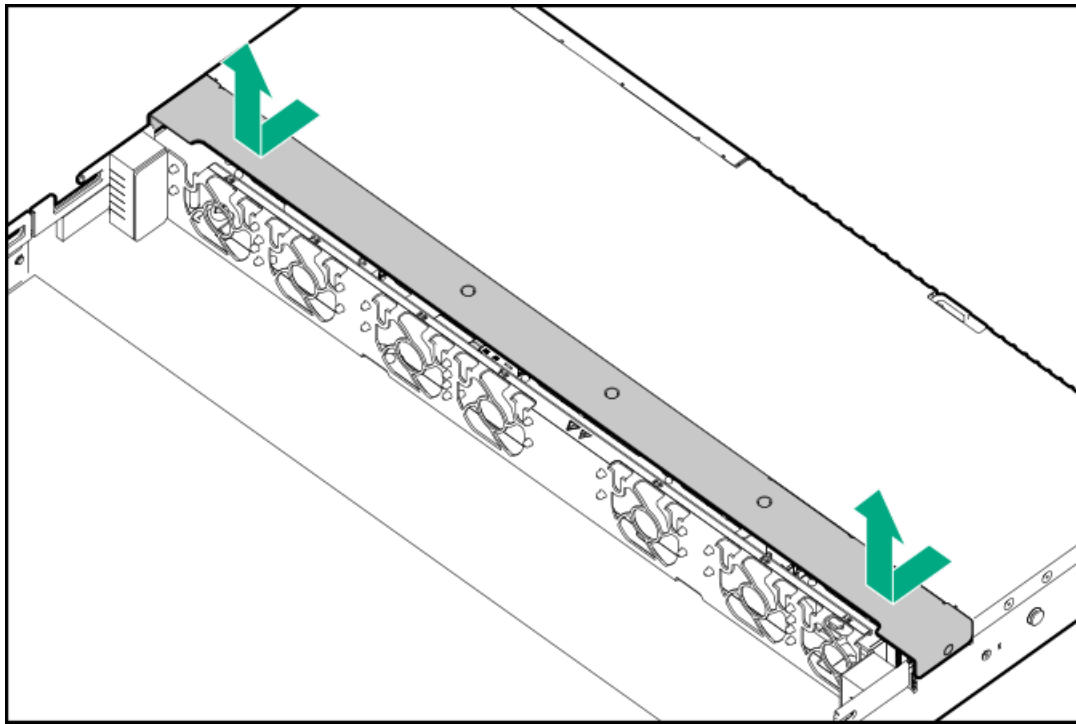

Results

The removal procedure is complete. To replace the component, reverse this procedure.

Power supply replacement

Depending on the configuration and the regional location where the server was purchased, the server can be configured with one of the supported [power supplies](#).

Subtopics

[Power supply warnings and cautions](#)

[Removing and replacing a power supply](#)

[Removing and replacing the power supply bay filler](#)

[Removing and replacing a power supply blank](#)

Power supply warnings and cautions



WARNING

To reduce the risk of electric shock or damage to the equipment:

- Do not disable the power cord grounding plug. The grounding plug is an important safety feature.
- Plug the power cord into a grounded (earthed) electrical outlet that is easily accessible at all times.
- Unplug the power cord from the power supply to disconnect power to the equipment.
- Do not route the power cord where it can be walked on or pinched by items placed against it. Pay particular attention to the plug, electrical outlet, and the point where the cord extends from the server.



WARNING

To reduce the risk of injury from electric shock hazards, do not open power supplies. Refer all maintenance, upgrades, and servicing to qualified personnel.



CAUTION

Mixing different types of power supplies in the same server might:

- Limit or disable some power supply features including support for power redundancy.
- Cause the system to become unstable and might shut down.

To ensure access to all available features, all power supplies in the same server should have the same output and efficiency ratings. Verify that all power supplies have the same part number and label color.

Removing and replacing a power supply

Prerequisites

Before replacing a power supply, review the [Power supply warnings and cautions](#).

About this task

- 60-mm M-CRPS

[https://sketchfab.com/models/7c58b5f665544c08a8cf5601772c45fa/embed?](https://sketchfab.com/models/7c58b5f665544c08a8cf5601772c45fa/embed?ui_infos=0&ui_watermark=0&ui_help=0&ui_vr=0&ui_settings=0&ui_inspector=0&ui_hint=2&ui_color=01a982&ui_theme=dark&autostart=1&camera=0)

[ui_infos=0&ui_watermark=0&ui_help=0&ui_vr=0&ui_settings=0&ui_inspector=0&ui_hint=2&ui_color=01a982&ui_theme=dark&autostart=1&camera=0](https://sketchfab.com/models/7c58b5f665544c08a8cf5601772c45fa/embed?ui_infos=0&ui_watermark=0&ui_help=0&ui_vr=0&ui_settings=0&ui_inspector=0&ui_hint=2&ui_color=01a982&ui_theme=dark&autostart=1&camera=0)

- 73.5-mm M-CRPS

[https://sketchfab.com/models/61d542c7fb504ebe8c57def38423ad69/embed?](https://sketchfab.com/models/61d542c7fb504ebe8c57def38423ad69/embed?ui_infos=0&ui_watermark=0&ui_help=0&ui_vr=0&ui_settings=0&ui_inspector=0&ui_hint=2&ui_color=01a982&ui_theme=dark&autostart=1&camera=0)

[ui_infos=0&ui_watermark=0&ui_help=0&ui_vr=0&ui_settings=0&ui_inspector=0&ui_hint=2&ui_color=01a982&ui_theme=dark&autostart=1&camera=0](https://sketchfab.com/models/61d542c7fb504ebe8c57def38423ad69/embed?ui_infos=0&ui_watermark=0&ui_help=0&ui_vr=0&ui_settings=0&ui_inspector=0&ui_hint=2&ui_color=01a982&ui_theme=dark&autostart=1&camera=0)



WARNING

To reduce the risk of personal injury from hot surfaces, allow the power supply, power supply blank, or dual slot power supply adapter to cool before touching it.



CAUTION

To prevent improper cooling and thermal damage, do not operate the server unless all bays are populated with either a component or a blank.

Procedure

1. [Power down the server](#).
2. Remove a power supply:



WARNING

To reduce the risk of personal injury, keep your fingers away from the attached left sliding rail when removing the power supply from the bay 1. The attached left sliding rail could scrape your fingers.

a. Release the power cord from the strain relief strap, and then disconnect the power cord from the power supply.

- 60-mm M-CRPS

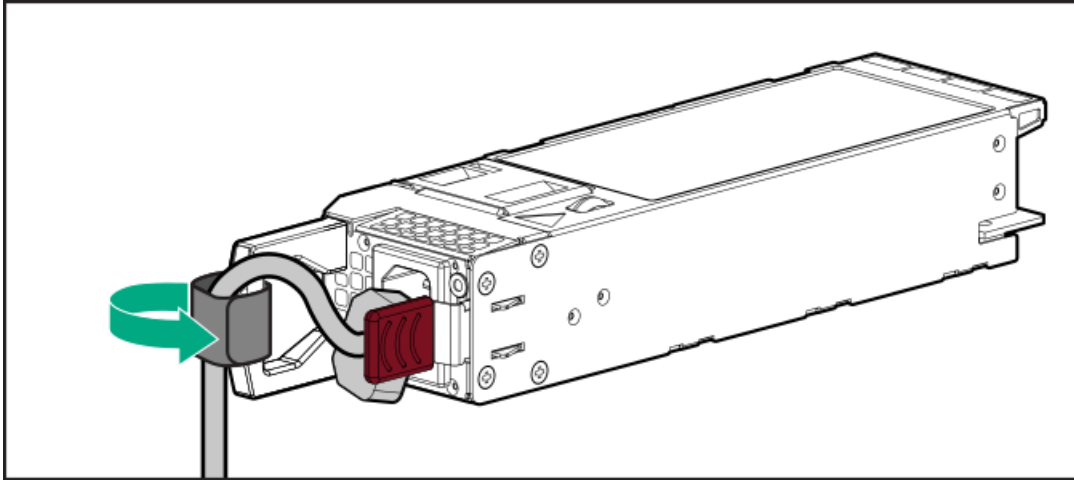

- 73.5-mm M-CRPS

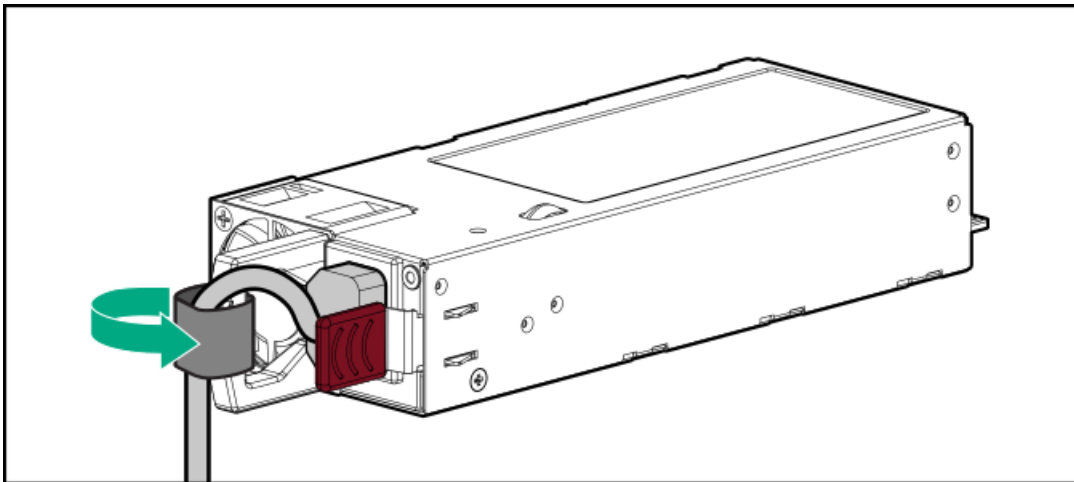

b. Press and hold the release latch, and then remove the power supply.

- 60-mm M-CRPS

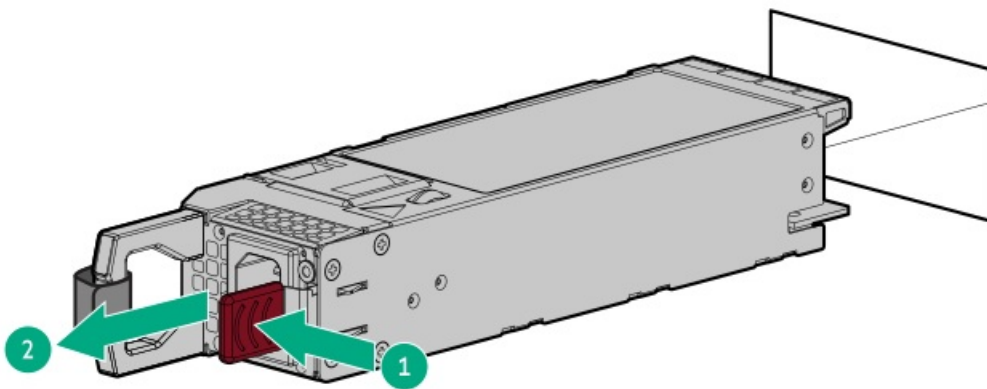

- 73.5-mm M-CRPS



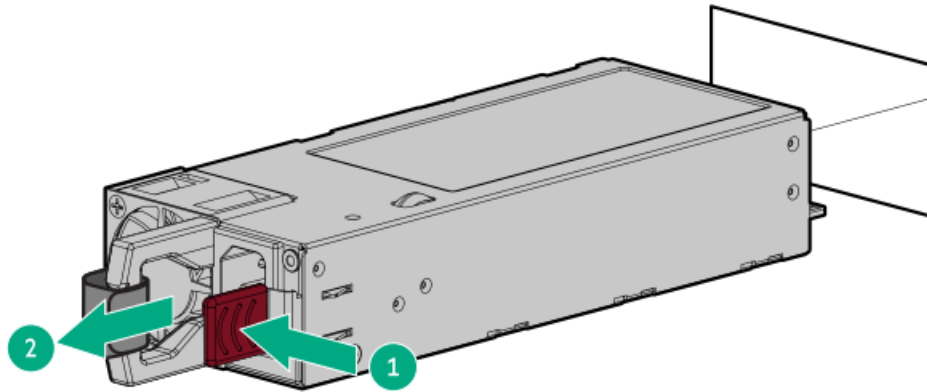

Results

The removal procedure is complete. To replace the component, reverse this procedure.

Removing and replacing the power supply bay filler

Prerequisites

Before you perform this procedure, make sure that you have a T-10 Torx screwdriver available.

About this task

https://sketchfab.com/models/05f8f821a805490985bd50ad3f26b689/embed?ui_infos=0&ui_watermark=0&ui_help=0&ui_vr=0&ui_settings=0&ui_inspector=0&ui_hint=2&ui_color=01a982&ui_theme=dark&autostart=1&camera=0&



WARNING

To reduce the risk of personal injury from hot surfaces, allow the power supply, power supply blank, or dual slot power supply adapter to cool before touching it.



CAUTION

To prevent improper cooling and thermal damage, do not operate the server unless all bays are populated with either a component or a blank.

Procedure

1. Power down the server.
2. If installed, release the cable management arm.
3. Remove all power:
 - a. Disconnect each power cord from the power source.
 - b. Disconnect each power cord from the server.
4. Disconnect all peripheral cables from the server.
5. Remove the server from the rack.
6. Place the server on a flat, level work surface.
7. Remove the access panel.

8. Remove the power supplies.
 9. If the filler is in bay 1, remove the energy pack bracket.
 - a. Press and hold the release latch.
 - b. Push the filler to detach it from the power supply bay.
 - c. Remove the filler.
- Bay 1:

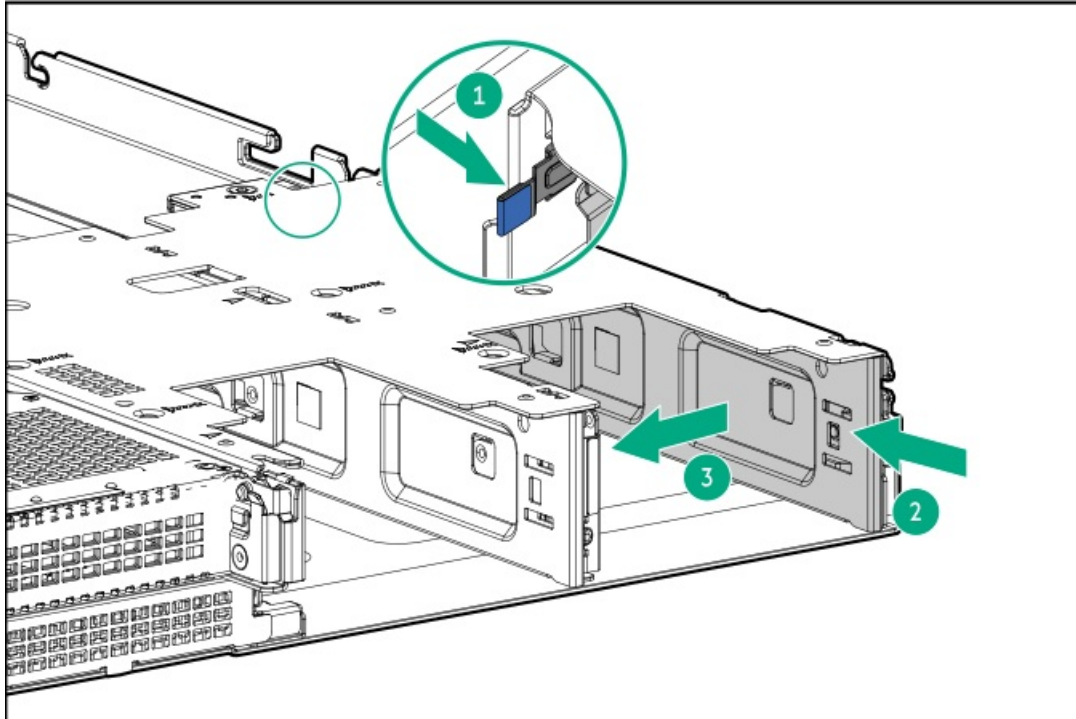

- Bay 2:

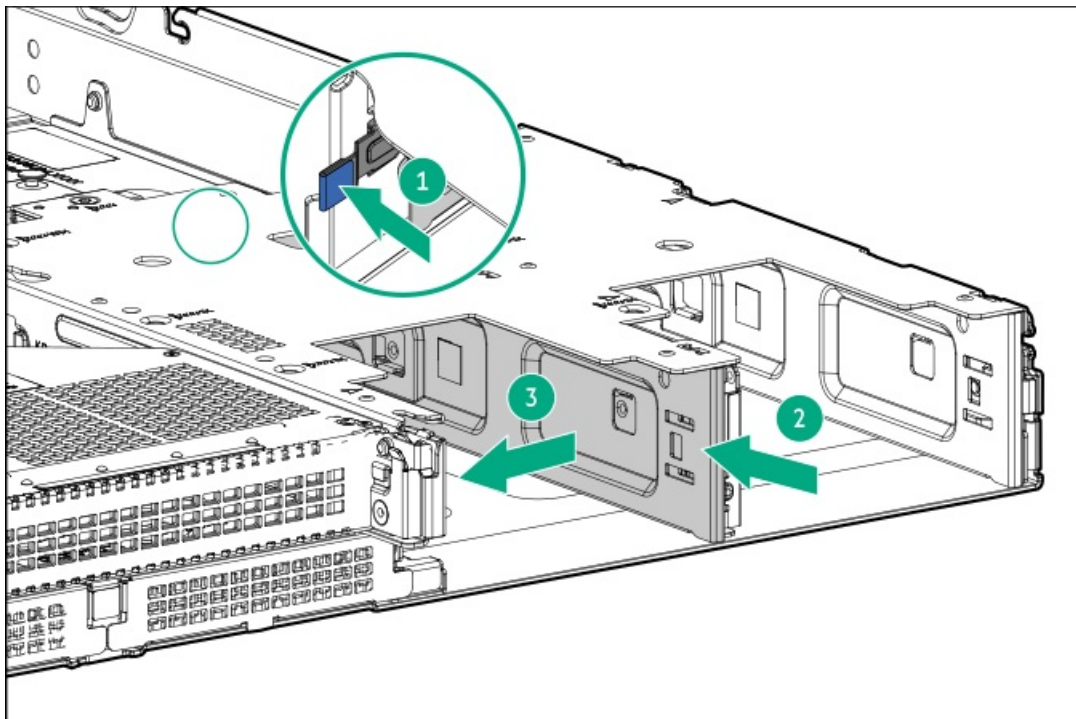

Results

The removal procedure is complete. To replace the component, reverse this procedure.

Removing and replacing a power supply blank

About this task



WARNING

To reduce the risk of personal injury from hot surfaces, allow the power supply, power supply blank, or dual slot power supply adapter to cool before touching it.



CAUTION

To prevent improper cooling and thermal damage, do not operate the server unless all bays are populated with either a component or a blank.

Procedure

1. Remove the power supply blank.

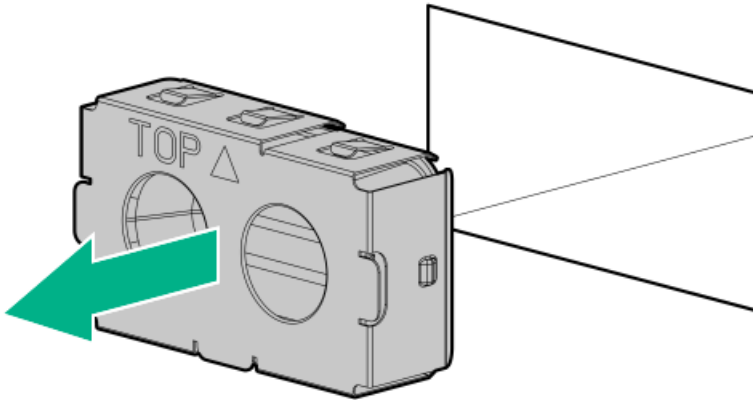

2. Immediately install the new power supply blank.

Removing and replacing the rack rails

Prerequisites

If you are replacing the rack mounting rails from a threaded-hole rack, make sure that you have a T-25 Torx screwdriver available.

About this task

https://sketchfab.com/models/7b55f5599368447a82781f373bcacc3d/embed?ui_infos=0&ui_watermark=0&ui_help=0&ui_vr=0&ui_settings=0&ui_inspector=0&ui_hint=2&ui_color=01a982&ui_theme=dark&autostart=1&camera=0&

The illustrations used in this procedure show an icon on the upper right corner of the image. This icon indicates whether the action shown in the image is for a round-hole, square-hole, or a threaded-hole rack.

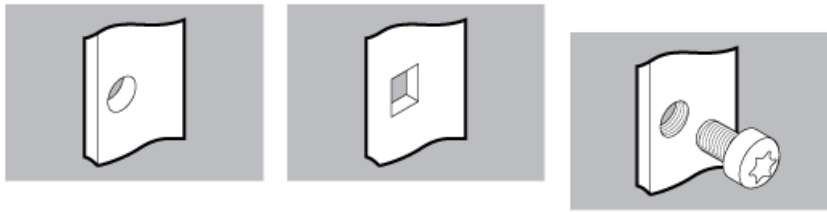

Round-hole rack Square-hole rack Threaded-hole rack

Procedure

1. Power down the server.
2. If installed, release the cable management arm.
3. Remove all power:
 - a. Disconnect each power cord from the power source.
 - b. Disconnect each power cord from the server.
4. Disconnect all peripheral cables from the server.
5. Remove the server from the rack.
6. Place the server on a flat, level work surface.
7. If you are replacing the inner rails, do the following:
 - a. Pull and hold the release tab.
 - b. Slide the rail towards the front panel and pull it away from the server.

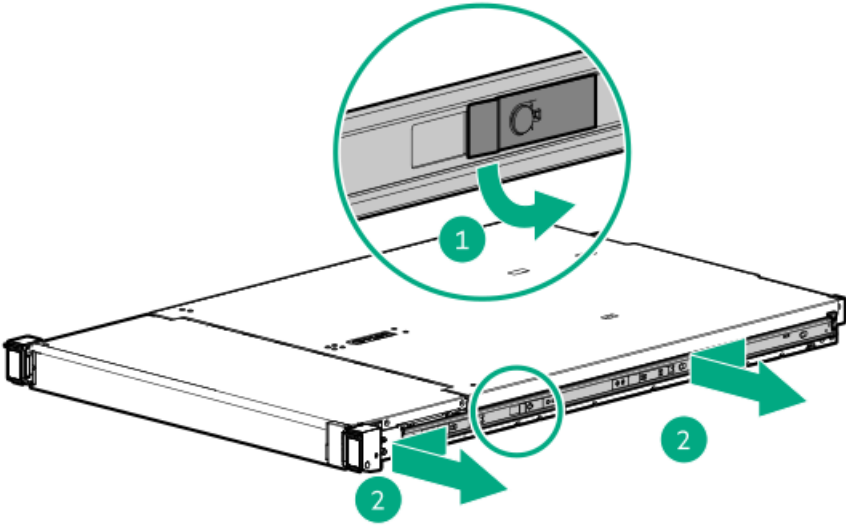

8. To remove the rack mounting rails, do the following:
 - a. In a threaded-hole rack, remove the rail screws.



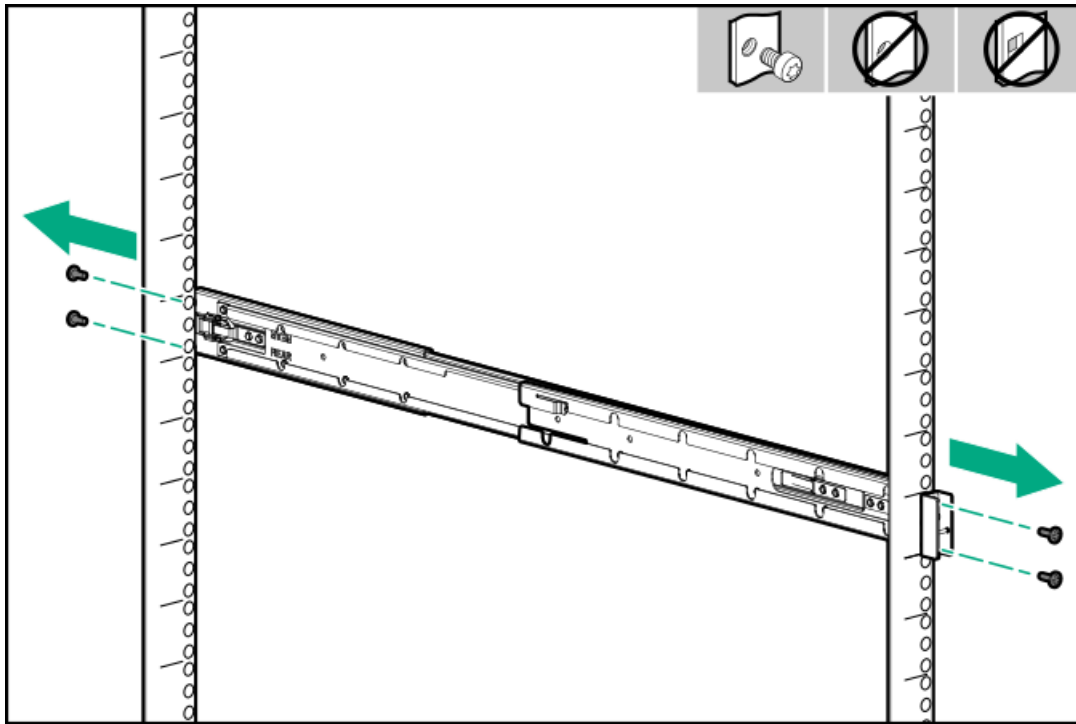

b. Press and hold the release latch, and then disengage the rail pins from the rack columns.

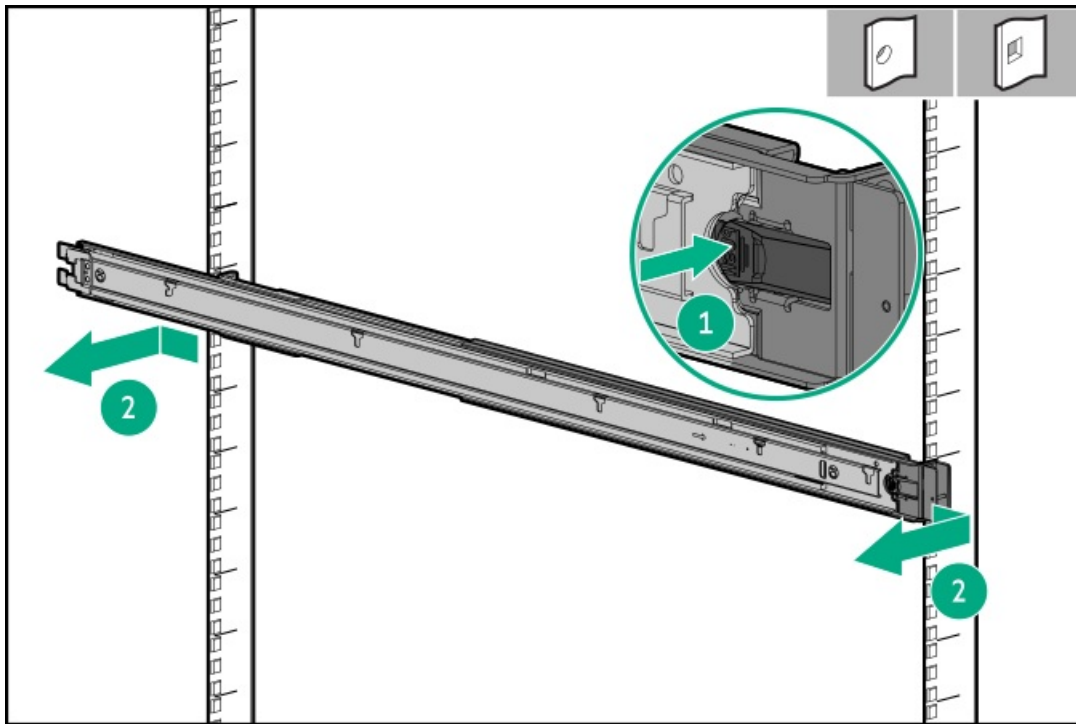

c. Repeat steps a and b to remove the other rack rail.

Results

The removal procedure is complete. To replace the component, reverse this procedure.

Front OCP NIC kit replacement

Subtopics



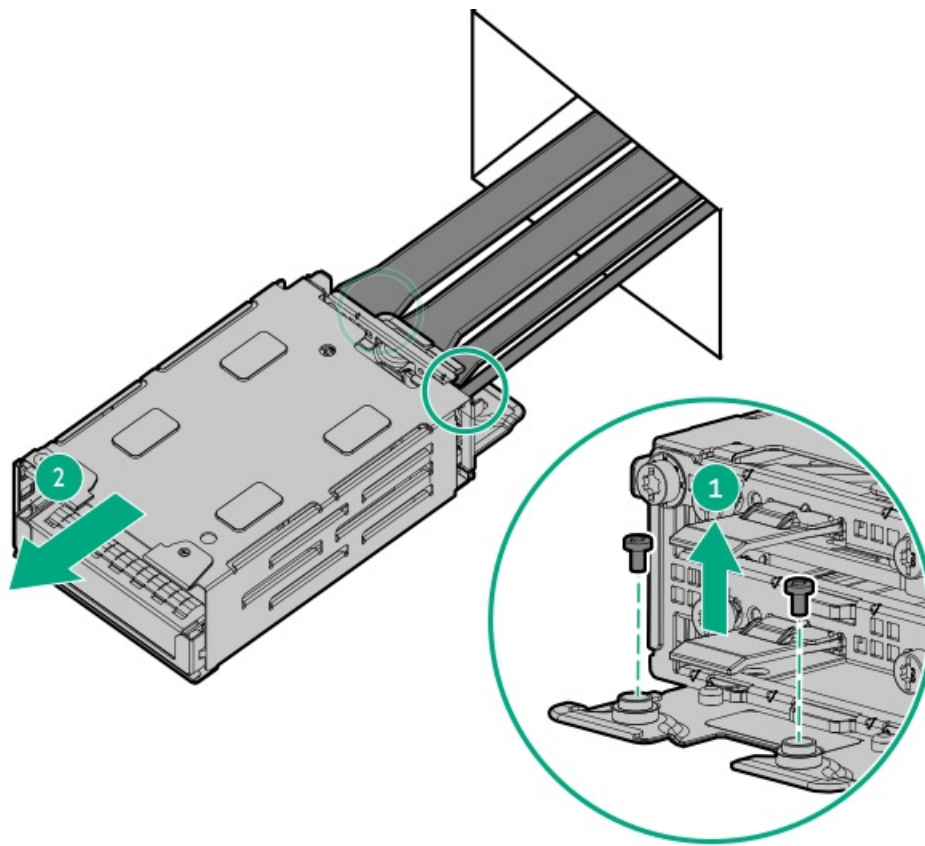

11. Remove the front OCP NIC adapter.

12. Remove the OCP NIC bracket.

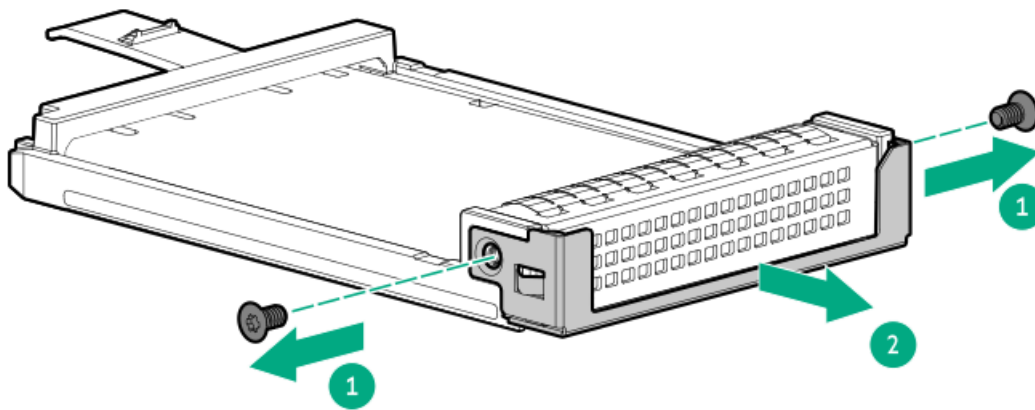

13. Slide the OCP NIC out of the OCP NIC carrier.

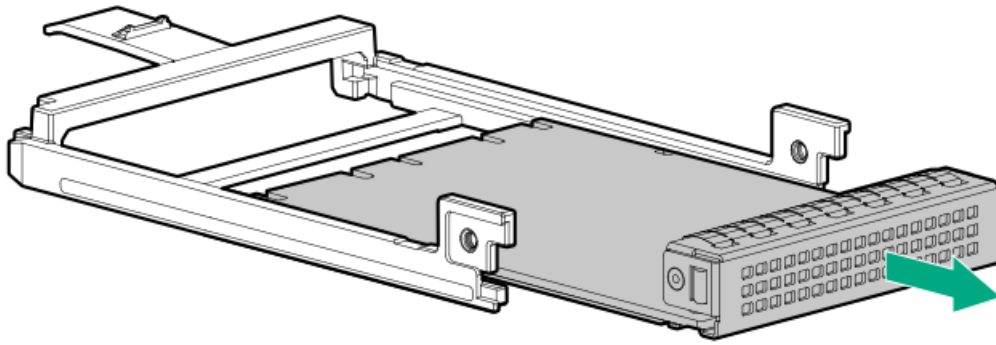

Results

The removal procedure is complete. To replace the component, reverse this procedure.

Removing and replacing a front OCP NIC adapter

About this task



CAUTION

A discharge of static electricity from a finger or other conductor might damage system boards or other static-sensitive devices. To prevent damage, observe [antistatic precautions](#).



CAUTION

To prevent improper cooling and thermal damage, do not operate the server unless all bays are populated with either a component or a blank.

Procedure

1. [Back up all server data](#).
2. [Power down the server](#).
3. If installed, [release the cable management arm](#).
4. Remove all power:
 - a. Disconnect each power cord from the power source.
 - b. Disconnect each power cord from the server.
5. Disconnect all peripheral cables from the server.
6. Do one of the following:
 - [Extend the server out of the rack](#).
 - [Remove the server from the rack](#).
7. If installed, [remove the front bezel](#).
8. [Remove the access panel](#).
9. [Remove the middle cover](#).

10. Disconnect the OCP cable from the system board and the interposer.
11. Remove the OCP NIC adapter.

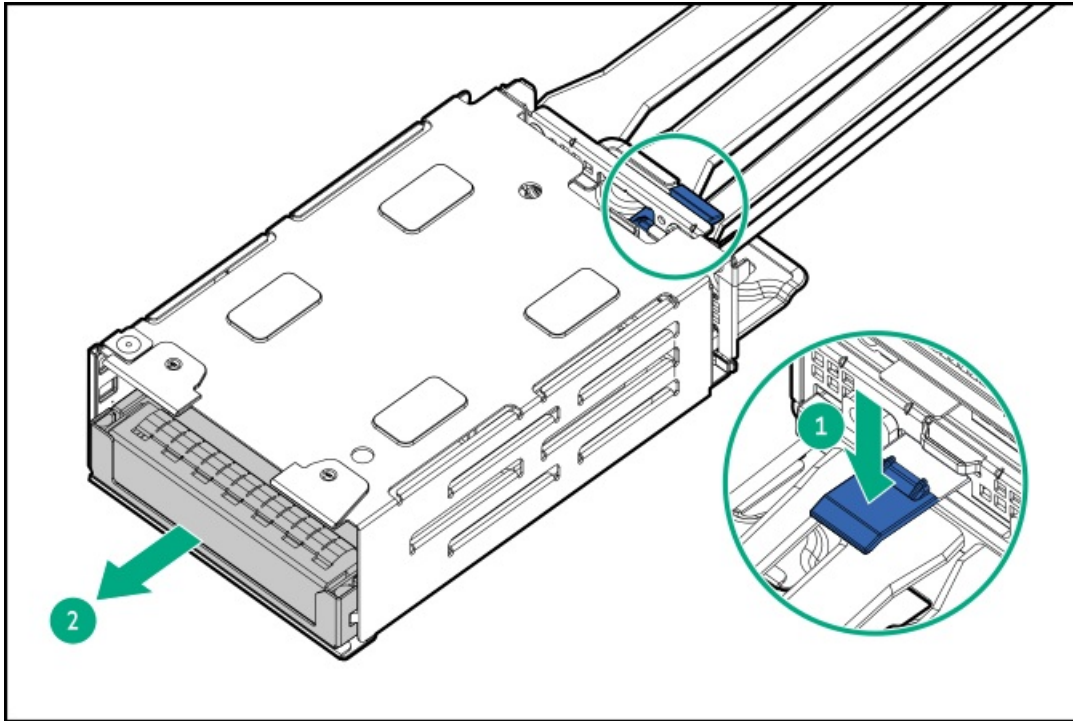

Results

The removal procedure is complete. To replace the component, reverse this procedure.

Removing and replacing the front OCP NIC cable

Prerequisites

Before you perform this procedure, make sure that you have a T-15 Torx screwdriver available.

About this task



CAUTION

A discharge of static electricity from a finger or other conductor might damage system boards or other static-sensitive devices. To prevent damage, observe [antistatic precautions](#).



CAUTION

To prevent improper cooling and thermal damage, do not operate the server unless all bays are populated with either a component or a blank.

Procedure

1. Back up all server data.
2. Power down the server.
3. If installed, release the cable management arm.
4. Remove all power:

- a. Disconnect each power cord from the power source.
- b. Disconnect each power cord from the server.
5. Disconnect all peripheral cables from the server.
6. Do one of the following:
 - Extend the server out of the rack.
 - Remove the server from the rack.
7. If installed, remove the front bezel.
8. Remove the access panel.
9. Remove the middle cover.
10. Disconnect the front OCP cable from the system board and the interposer.
11. Remove the multipurpose cage.

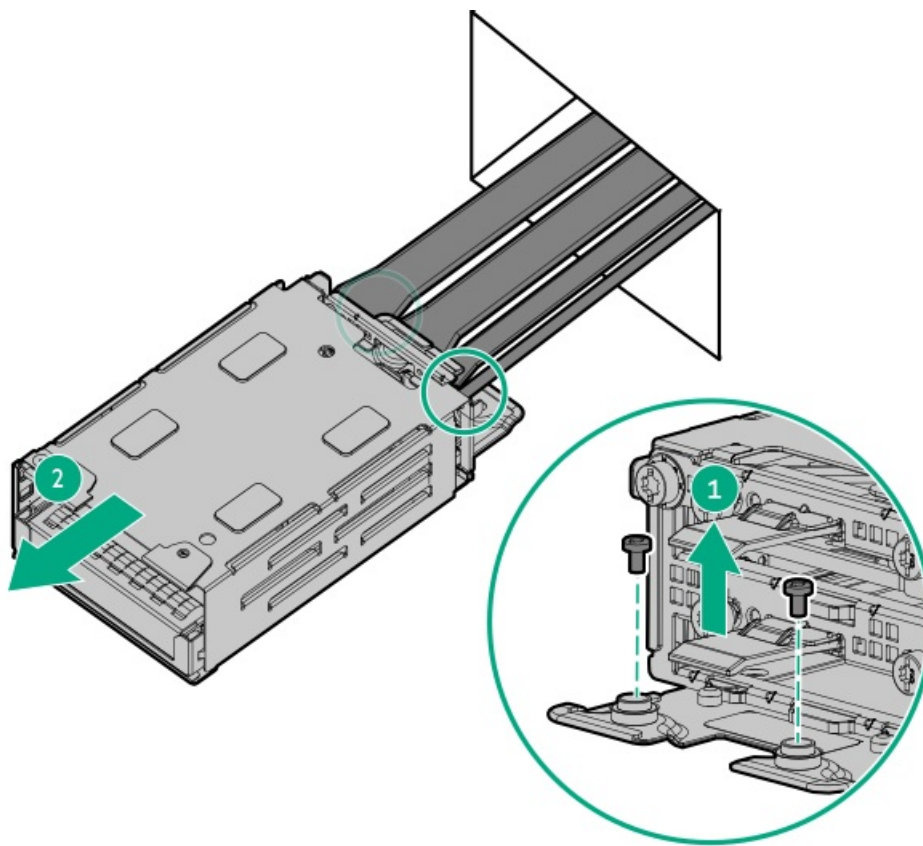

12. Remove the OCP NIC adapter.
13. Disconnect the front OCP NIC cable from the PHY board.
14. Remove the OCP NIC cable.

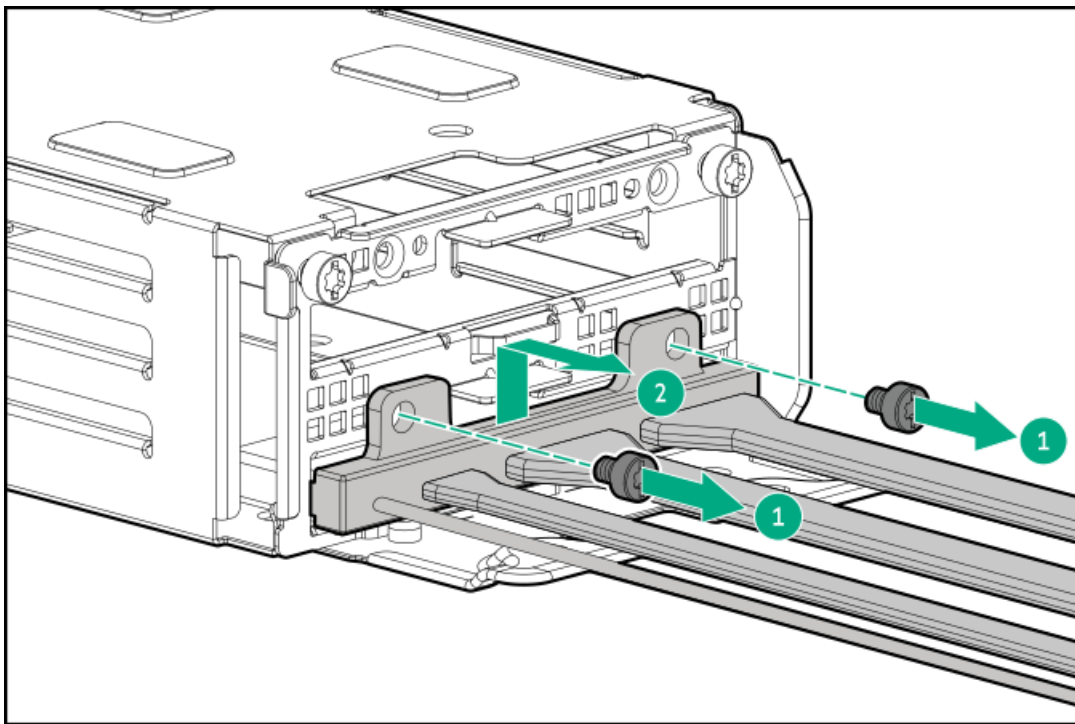

Results

The removal procedure is complete. To replace the component, reverse this procedure.

Removing and replacing a E3.S drive filler

Prerequisites

Before you perform this procedure, make sure that you have a T-15 Torx screwdriver available.

About this task



CAUTION

A discharge of static electricity from a finger or other conductor might damage system boards or other static-sensitive devices. To prevent damage, observe [antistatic precautions](#).



CAUTION

To prevent improper cooling and thermal damage, do not operate the server unless all bays are populated with either a component or a blank.

Procedure

1. [Back up all server data](#).
2. [Power down the server](#).
3. If installed, [remove the front bezel](#).
4. If installed, [release the cable management arm](#).
5. Remove all power:
 - a. Disconnect each power cord from the power source.
 - b. Disconnect each power cord from the server.

6. Disconnect all peripheral cables from the server.
7. Do one of the following:
 - Extend the server out of the rack.
 - Remove the server from the rack.
8. Remove the access panel.
9. Remove the middle cover.
10. Disconnect the OCP cable from the system board and the interposer.
11. Remove the multipurpose cage.

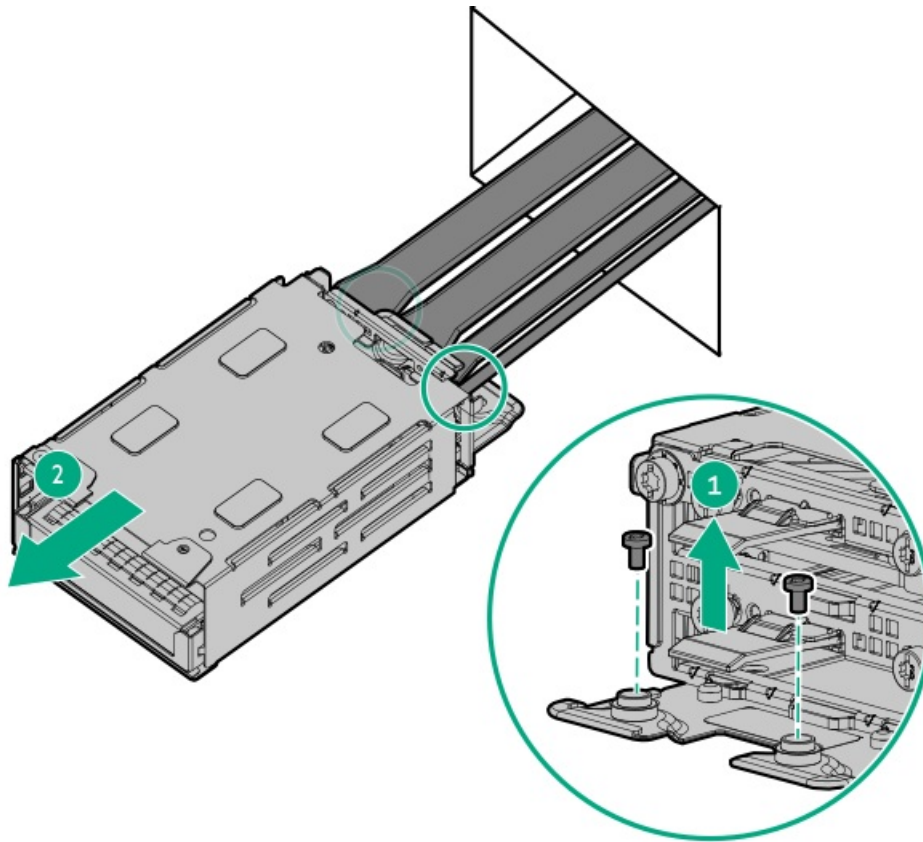

12. Remove the E3.S drive filler out of the cage.
 - a. Insert a small-slotted screwdriver into the slot to push the release latch.
 - b. Remove the E3.S drive cage filler.

The screwdriver is not needed to reinstall the component.

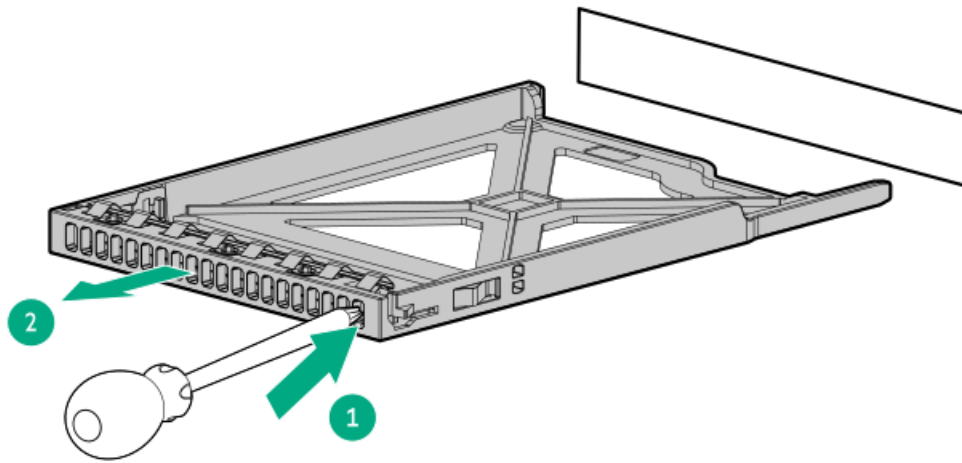

Results

The removal procedure is complete. To replace the component, reverse this procedure.

Removing and replacing the PHY board

Prerequisites

Before you perform this procedure, make sure that you have a T-15 Torx screwdriver available.

About this task



CAUTION

Before replacing a DIMM, backplane, expansion card, riser board, or other similar PCA components due to a perceived hardware error, make sure first that the component is firmly seated in the slot.

When installing the replacement component:

- Observe antistatic precautions.
- Handle the PCA only along the edges.
- Do not touch the components and connectors on the PCA.
- Do not bend or flex the PCA.

Procedure

1. Back up all server data.
2. Power down the server.
3. If installed, release the cable management arm.
4. Remove all power:
 - a. Disconnect each power cord from the power source.
 - b. Disconnect each power cord from the server.
5. Disconnect all peripheral cables from the server.
6. Do one of the following:

- Extend the server out of the rack.
 - Remove the server from the rack.
7. If installed, remove the front bezel.
 8. Remove the access panel.
 9. Remove the middle cover.
 10. Disconnect the OCP cable from the system board and the interposer.
 11. Disconnect the front OCP NIC cable from the PHY board.
 12. Remove the PHY board.

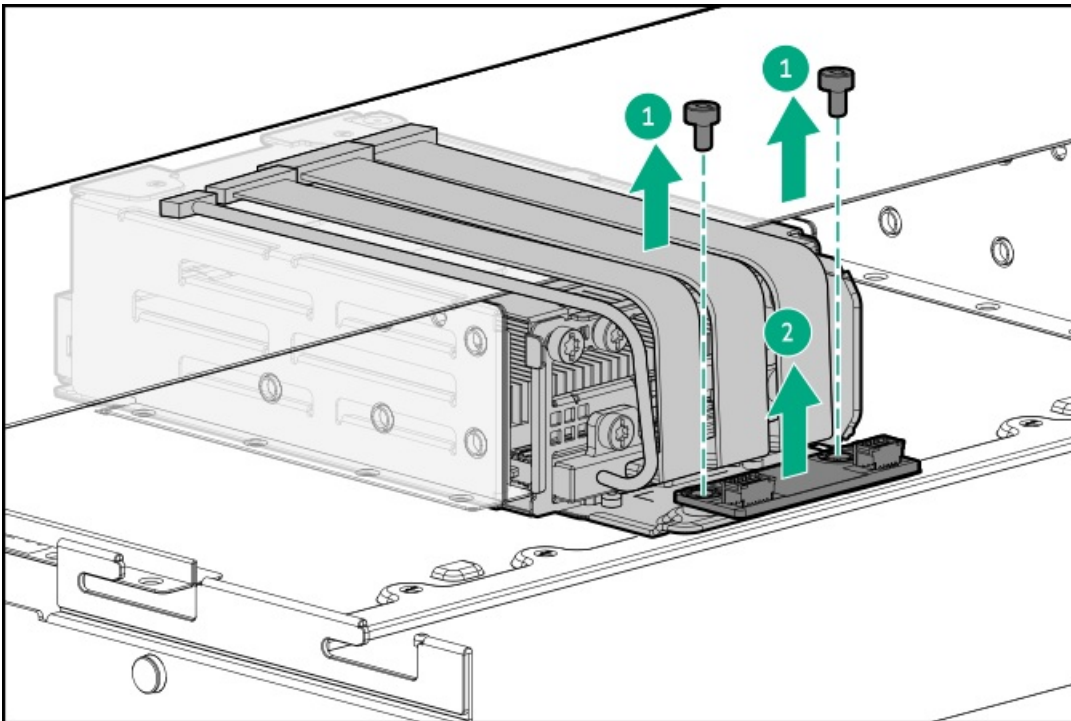

Results

The removal procedure is complete. To replace the component, reverse this procedure.

Removing and replacing the OCP NIC interposer

About this task



CAUTION

Before replacing a DIMM, backplane, expansion card, riser board, or other similar PCA components due to a perceived hardware error, make sure first that the component is firmly seated in the slot.

When installing the replacement component:

- Observe antistatic precautions.
- Handle the PCA only along the edges.
- Do not touch the components and connectors on the PCA.
- Do not bend or flex the PCA.



CAUTION

To prevent improper cooling and thermal damage, do not operate the server unless all OCP slots have either an OCP option or a slot blank installed.

Procedure

1. Back up all server data.
2. Power down the server.
3. If installed, release the cable management arm.
4. Remove all power:
 - a. Disconnect each power cord from the power source.
 - b. Disconnect each power cord from the server.
5. Disconnect all peripheral cables from the server.
6. Do one of the following:
 - Extend the server out of the rack.
 - Remove the server from the rack.
7. Remove the access panel.
8. If installed, remove the secondary riser cage.
9. Disconnect the front OCP NIC cable from the OCP NIC interposer.
10. Remove the OCP NIC interposer:
 - a. Pivot the locking pin to the open (vertical) position.
 - b. Push the blue touch point to disengage the interposer from the slot.
 - c. Remove the interposer from the slot.

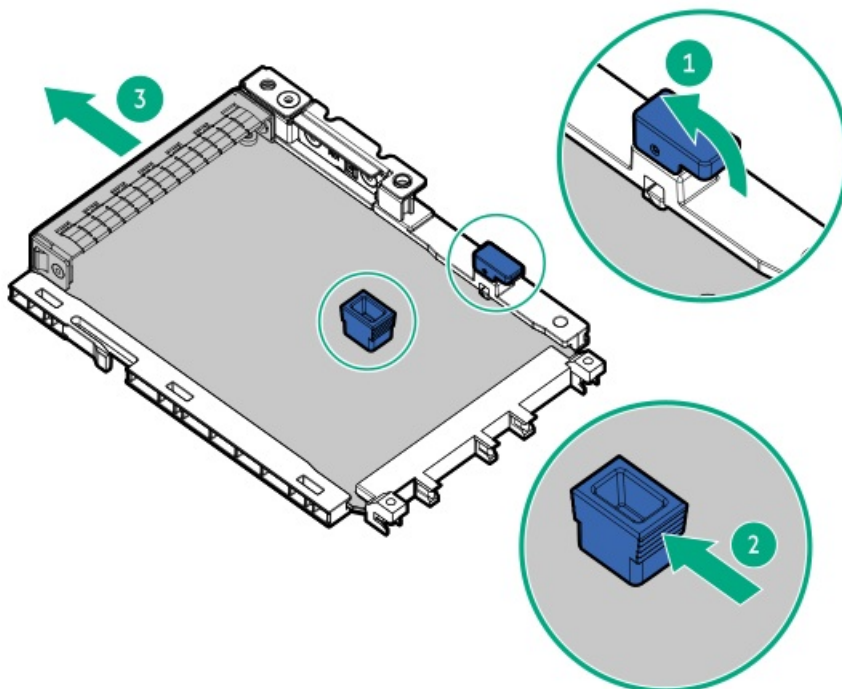

Results

The removal procedure is complete. To replace the component, reverse this procedure.

Drive backplane replacement

Subtopics

[Removing and replacing the 2 SFF drive backplane](#)

[Removing and replacing the 2 SFF or 4 E3.S drive backplane from the mixed or GPU-optimized drive configuration](#)

[Removing and replacing the 8 SFF drive backplane](#)

[Removing and replacing the 4 LFF drive backplane](#)

[Removing and replacing the 4 E3.S drive backplane](#)

Removing and replacing the 2 SFF drive backplane

About this task



CAUTION

A discharge of static electricity from a finger or other conductor might damage system boards or other static-sensitive devices. To prevent damage, observe [antistatic precautions](#).



CAUTION

Before replacing a DIMM, backplane, expansion card, riser board, or other similar PCA components due to a perceived hardware error, make sure first that the component is firmly seated in the slot.

When installing the replacement component:

- Observe [antistatic precautions](#).
- Handle the PCA only along the edges.
- Do not touch the components and connectors on the PCA.
- Do not bend or flex the PCA.

Procedure

1. [Power down the server](#).
2. If installed, [release the cable management arm](#).
3. Remove all power:
 - a. Disconnect each power cord from the power source.
 - b. Disconnect each power cord from the server.
4. Disconnect all peripheral cables from the server.
5. [Remove the server from the rack](#).
6. Place the server on a flat, level work surface.
7. [Remove the access panel](#).
8. [Remove the middle cover](#).
9. [Remove the fans](#).

10. Remove the fan wall.
11. Remove all drives from the 2 SFF drive cage .
12. Disconnect all cables from the drive backplane.
 - Drive power cable
 - Drive controller cable
13. Pull up the release latch and detach the backplane.

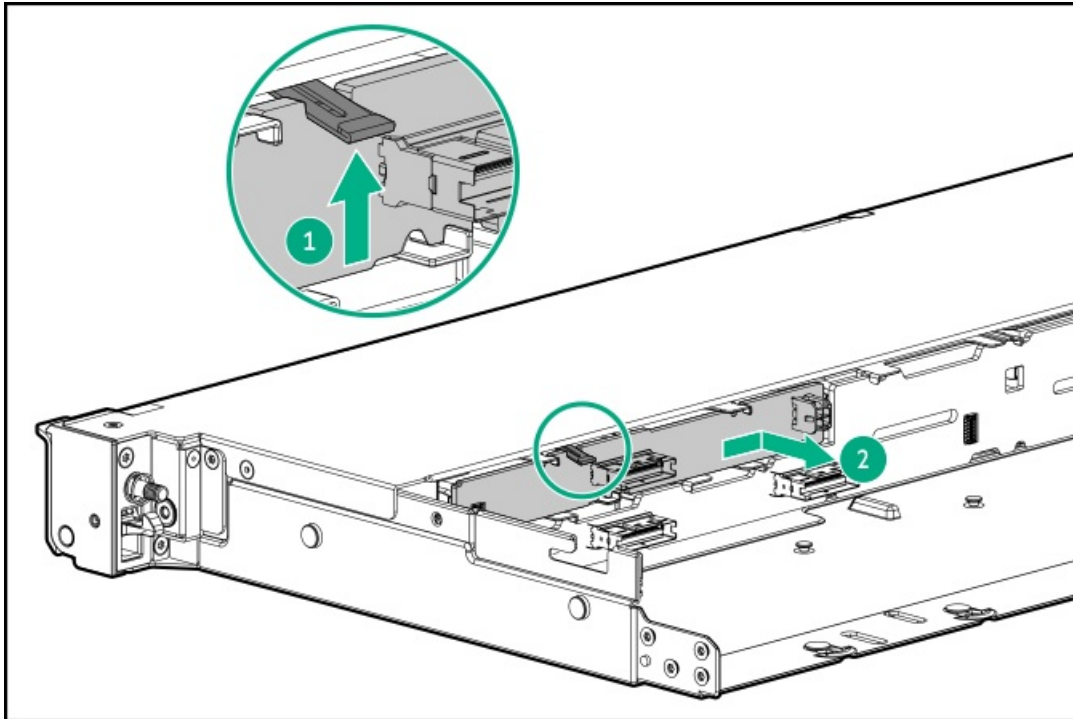

Results

The removal procedure is complete. To replace the component, reverse this procedure.

Removing and replacing the 2 SFF or 4 E3.S drive backplane from the mixed or GPU-optimized drive configuration

Prerequisites

Before you perform this procedure, make sure that you have a T-15 Torx screwdriver available.

About this task



CAUTION

A discharge of static electricity from a finger or other conductor might damage system boards or other static-sensitive devices. To prevent damage, observe antistatic precautions.



CAUTION

Before replacing a DIMM, backplane, expansion card, riser board, or other similar PCA components due to a perceived hardware error, make sure first that the component is firmly seated in the slot.

When installing the replacement component:

- Observe antistatic precautions.
- Handle the PCA only along the edges.
- Do not touch the components and connectors on the PCA.
- Do not bend or flex the PCA.

Procedure

1. Power down the server.
2. If installed, release the cable management arm.
3. Remove all power:
 - a. Disconnect each power cord from the power source.
 - b. Disconnect each power cord from the server.
4. Disconnect all peripheral cables from the server.
5. Remove the server from the rack.
6. Place the server on a flat, level work surface.
7. Remove the access panel.
8. Remove the middle cover.
9. Remove all drives from the 2 SFF drive cage .
10. Disconnect all cables from the drive backplane.
 - Drive power cable
 - Drive controller cable
11. Remove the screws, and then remove the drive cage.

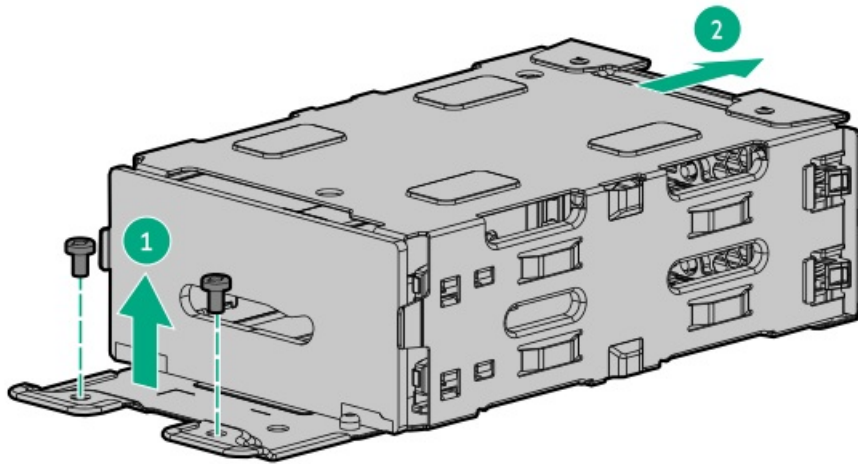

12. Remove the screws, and then remove the drive backplane.

Retain the screws. These screws will be used to secure the new spare backplane.

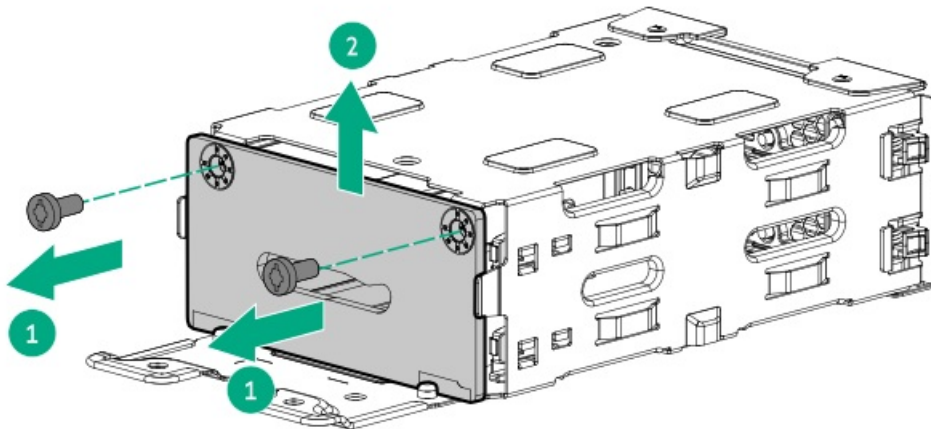

Results

The removal procedure is complete. To replace the component, reverse this procedure.

Removing and replacing the 8 SFF drive backplane

About this task





CAUTION

A discharge of static electricity from a finger or other conductor might damage system boards or other static-sensitive devices. To prevent damage, observe antistatic precautions.



CAUTION

Before replacing a DIMM, backplane, expansion card, riser board, or other similar PCA components due to a perceived hardware error, make sure first that the component is firmly seated in the slot.

When installing the replacement component:

- Observe antistatic precautions.
- Handle the PCA only along the edges.
- Do not touch the components and connectors on the PCA.
- Do not bend or flex the PCA.

Procedure

1. Power down the server.
2. If installed, release the cable management arm.
3. Remove all power:
 - a. Disconnect each power cord from the power source.
 - b. Disconnect each power cord from the server.
4. Disconnect all peripheral cables from the server.
5. Remove the server from the rack.
6. Place the server on a flat, level work surface.
7. Remove the access panel.
8. Remove the middle cover.
9. Remove the fans.
10. Remove the fan wall.
11. Remove the energy pack retention latch.
12. Remove all drives.
13. Disconnect all cables from the drive backplane.
 - Drive power cable
 - Drive controller cable
14. Pull up the release latch and detach the backplane.

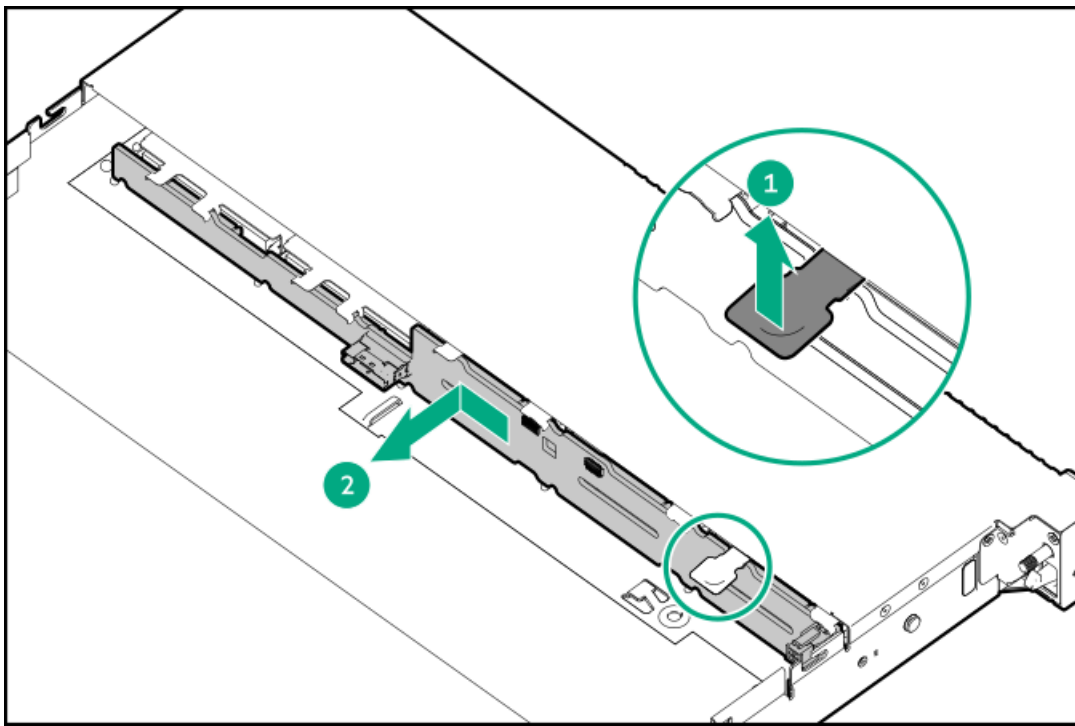

Results

To replace the component, reverse the removal procedure.

Removing and replacing the 4 LFF drive backplane

Prerequisites

Before you perform this procedure, make sure that you have a T-15 Torx screwdriver available.

About this task



CAUTION

A discharge of static electricity from a finger or other conductor might damage system boards or other static-sensitive devices. To prevent damage, observe [antistatic precautions](#).



CAUTION

Before replacing a DIMM, backplane, expansion card, riser board, or other similar PCA components due to a perceived hardware error, make sure first that the component is firmly seated in the slot.

When installing the replacement component:

- Observe [antistatic precautions](#).
- Handle the PCA only along the edges.
- Do not touch the components and connectors on the PCA.
- Do not bend or flex the PCA.

Procedure

1. [Power down the server](#).

2. If installed, release the cable management arm.
3. Remove all power:
 - a. Disconnect each power cord from the power source.
 - b. Disconnect each power cord from the server.
4. Disconnect all peripheral cables from the server.
5. Remove the server from the rack.
6. Place the server on a flat, level work surface.
7. Remove the access panel.
8. Remove the middle cover.
9. Remove the fans.
10. Remove the fan wall.
11. Remove the energy pack retention latch.
12. Remove all drives.
13. Disconnect all cables from the drive backplane.
 - Drive power cable
 - Drive controller cable
14. Remove the 4 LFF drive backplane.

Retain the screws. These screws will be used to secure the new drive backplane spare.

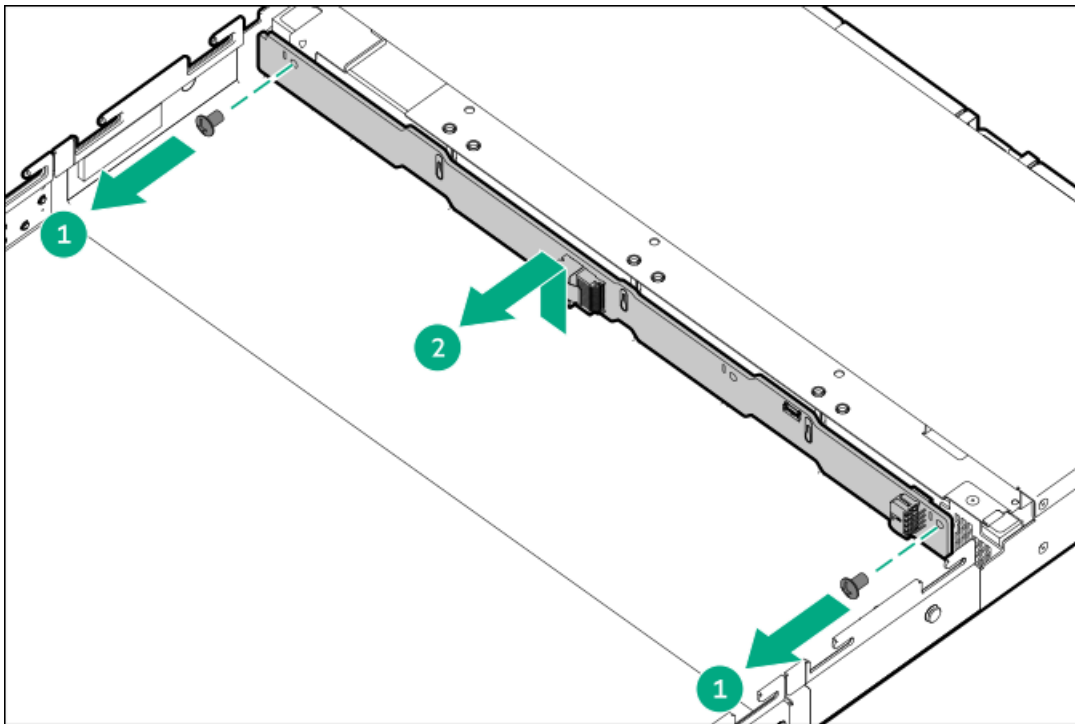

Results

The removal procedure is complete. To replace the component, reverse this procedure.

Removing and replacing the 4 E3.S drive backplane

Prerequisites

Before you perform this procedure, make sure that you have a T-15 Torx screwdriver available.

About this task



CAUTION

A discharge of static electricity from a finger or other conductor might damage system boards or other static-sensitive devices. To prevent damage, observe [antistatic precautions](#).



CAUTION

Before replacing a DIMM, backplane, expansion card, riser board, or other similar PCA components due to a perceived hardware error, make sure first that the component is firmly seated in the slot.

When installing the replacement component:

- Observe [antistatic precautions](#).
- Handle the PCA only along the edges.
- Do not touch the components and connectors on the PCA.
- Do not bend or flex the PCA.

Procedure

1. [Power down the server](#).
2. If installed, [release the cable management arm](#).
3. Remove all power:
 - a. Disconnect each power cord from the power source.
 - b. Disconnect each power cord from the server.
4. Disconnect all peripheral cables from the server.
5. [Remove the server from the rack](#).
6. Place the server on a flat, level work surface.
7. [Remove the access panel](#).
8. [Remove the middle cover](#).
9. [Remove all drives from the drive cage](#).
10. Disconnect all cables from the drive backplane.
 - [Drive power cable](#)
 - [Drive controller cable](#)
11. Remove the screws, and then remove the drive cage.

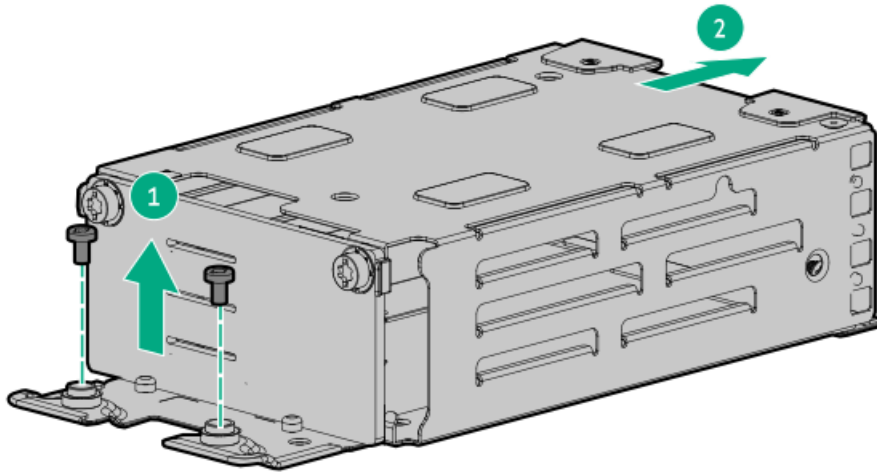

- Remove the screws, and then remove the drive backplane.

Retain the screws. These screws will be used to secure the new spare backplane.

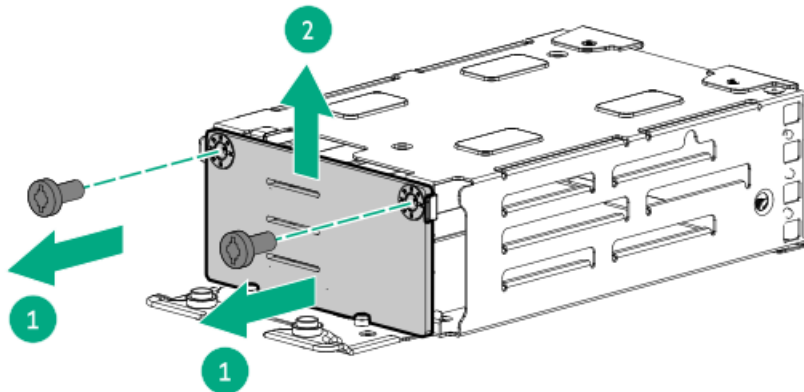

Results

The removal procedure is complete. To replace the component, reverse this procedure.

Optical drive replacement

Subtopics

[Removing and replacing the optical drive from the 8 SFF drive configuration](#)

[Removing and replacing an optical drive from the LFF drive configuration](#)

[Removing and replacing the optical disk drive from the mixed drive configuration](#)

Removing and replacing the optical drive from the 8 SFF drive configuration

Prerequisites

Before you perform this procedure, make sure that you have the following items available:

- T-10 Torx screwdriver
- T-15 Torx screwdriver
- Phillips No. 1 screwdriver

About this task



CAUTION

A discharge of static electricity from a finger or other conductor might damage system boards or other static-sensitive devices. To prevent damage, observe [antistatic precautions](#).



CAUTION

To prevent improper cooling and thermal damage, do not operate the server unless all bays are populated with either a component or a blank.

Procedure

1. [Power down the server](#).
2. If installed, [remove the front bezel](#).
3. If installed, [release the cable management arm](#).
4. Remove all power:
 - a. Disconnect each power cord from the power source.
 - b. Disconnect each power cord from the server.
5. Disconnect all peripheral cables from the server.
6. Do one of the following:
 - [Extend the server out of the rack](#).
 - [Remove the server from the rack](#).
7. [Remove the access panel](#).
8. [Remove the middle cover](#).
9. Disconnect following cables from the system board:
 - [Optical drive SlimSAS-power Y-cable](#)
 - [Front USB and Display port cable](#)
10. Remove the optical drive cage from the universal media bay.

Retain the screws. These screws will be used to secure the cage after the optical drive replacement.

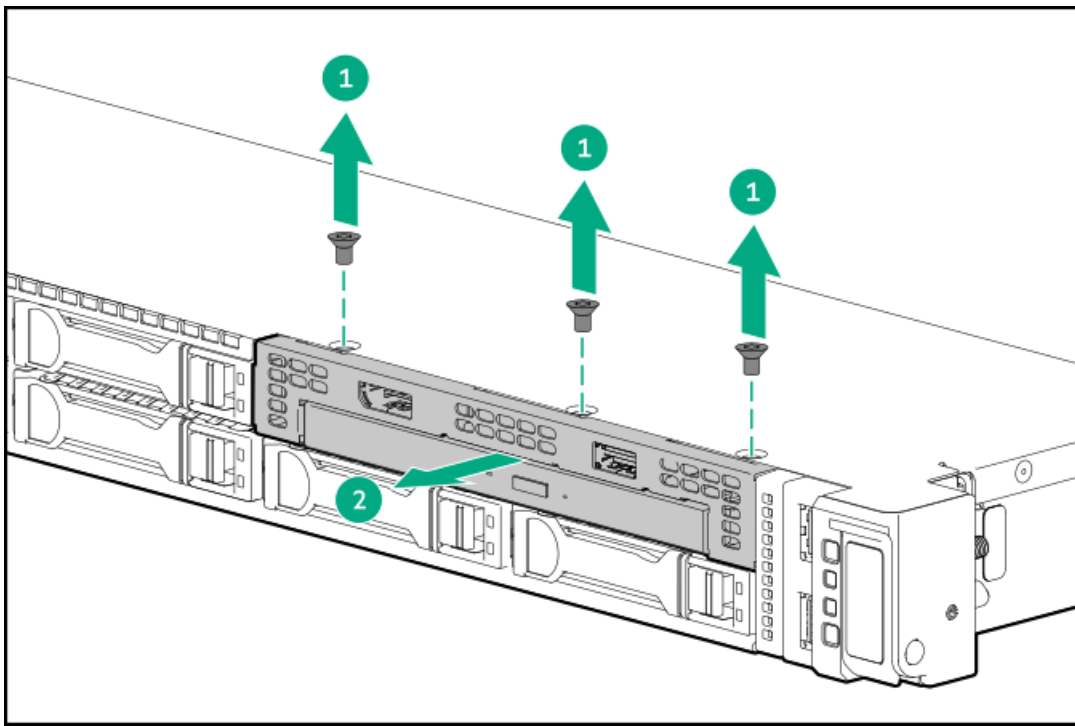

11. Remove the optical drive from the drive cage.

Retain the screw. This screw will be used to secure the new optical drive spare.

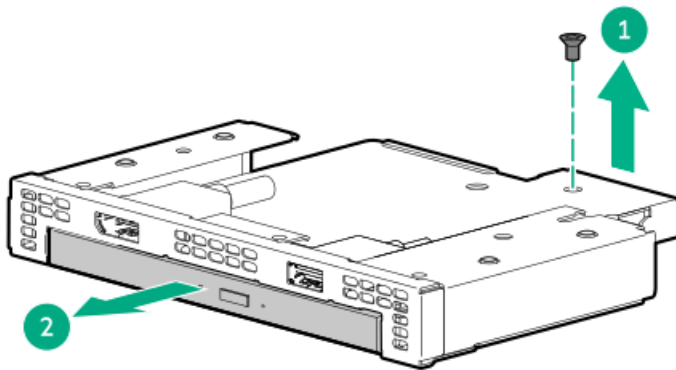

12. Remove the optical drive bracket.

Retain the screws and bracket. These screws will be used to secure the bracket on the new optical drive spare.





Results

The removal procedure is complete. To replace the component, reverse this procedure.

Removing and replacing an optical drive from the LFF drive configuration

Prerequisites

Before you perform this procedure, make sure that you have the following items available:

- T-10 Torx screwdriver
- Phillips No. 1 screwdriver

About this task



CAUTION

A discharge of static electricity from a finger or other conductor might damage system boards or other static-sensitive devices. To prevent damage, observe [antistatic precautions](#).



CAUTION

To prevent improper cooling and thermal damage, do not operate the server unless all bays are populated with either a component or a blank.

Procedure

1. [Power down the server](#).
2. If installed, [remove the front bezel](#).
3. If installed, [release the cable management arm](#).
4. Remove all power:
 - a. Disconnect each power cord from the power source.

- b. Disconnect each power cord from the server.
5. Disconnect all peripheral cables from the server.
6. Do one of the following:
 - Extend the server out of the rack.
 - Remove the server from the rack.
7. Remove the access panel.
8. Remove the middle cover.
9. Disconnect following cables from the system board:
 - Optical drive SlimSAS-power Y-cable
 - Front USB and Display port cable
10. Remove the optical drive.

Retain the screw. The screw will be used to secure the new optical drive spare.

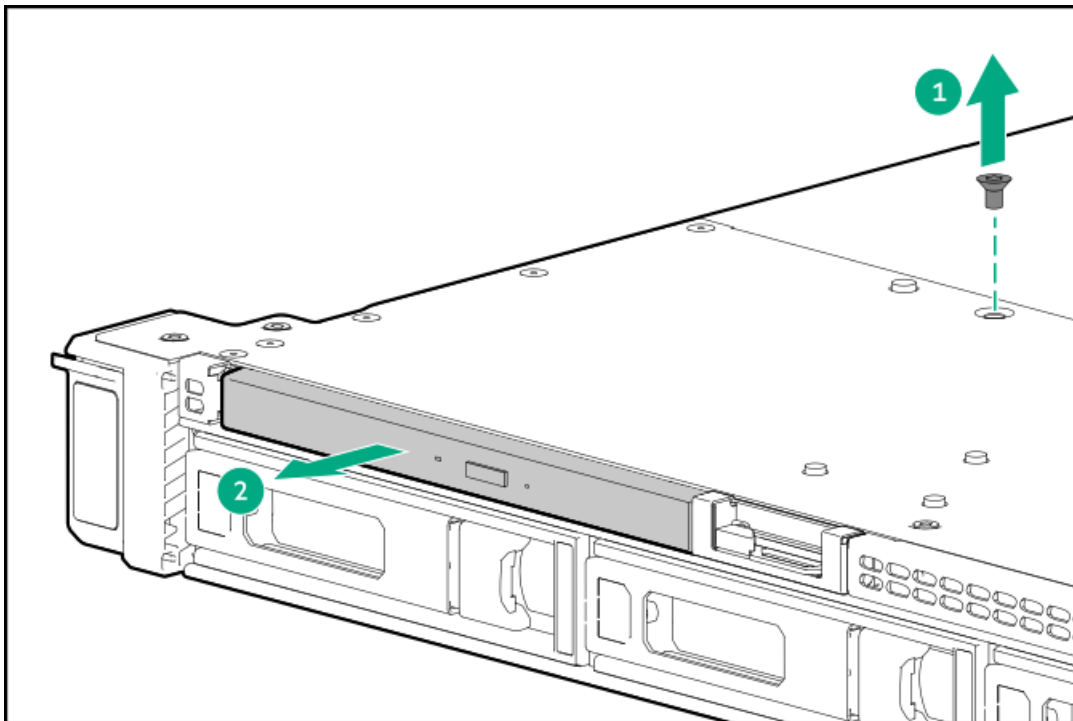

11. Remove the optical drive bracket.

Retain the screws and bracket. These screws will be used to secure the bracket on the new optical drive spare.

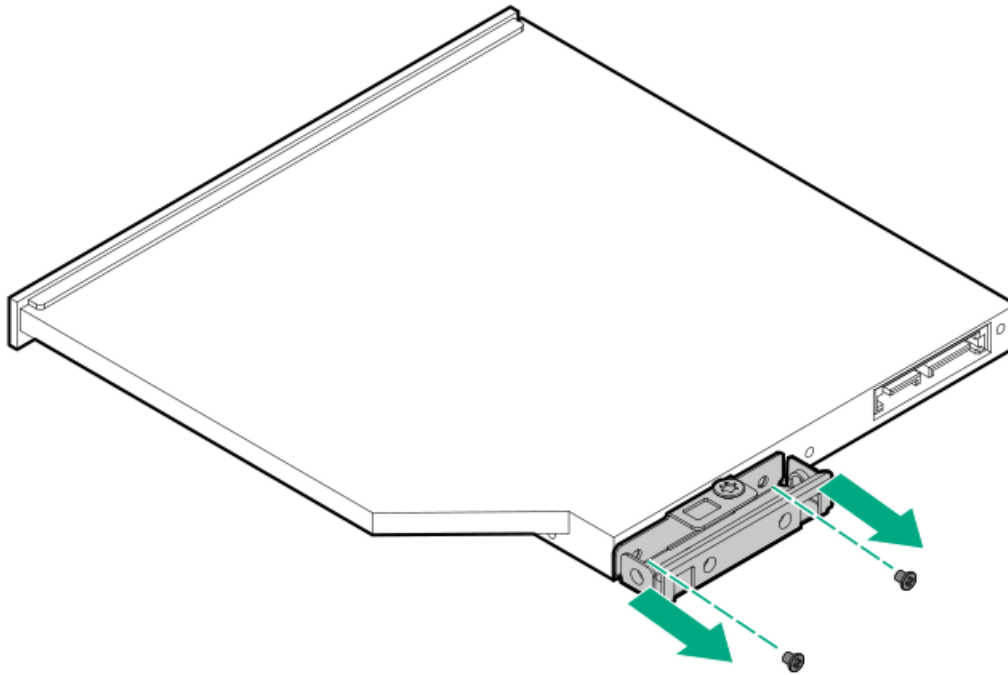

Results

The removal procedure is complete. To replace the component, reverse this procedure.

Removing and replacing the optical disk drive from the mixed drive configuration

Prerequisites

Before you perform this procedure, make sure that you have a T-10 Torx screwdriver available.

About this task



CAUTION

To prevent improper cooling and thermal damage, do not operate the server unless all bays are populated with either a component or a blank.



CAUTION

A discharge of static electricity from a finger or other conductor might damage system boards or other static-sensitive devices. To prevent damage, observe [antistatic precautions](#).

Procedure

1. [Power down the server](#).
2. If installed, [remove the front bezel](#).
3. If installed, [release the cable management arm](#).
4. Remove all power:
 - a. Disconnect each power cord from the power source.
 - b. Disconnect each power cord from the server.
5. Disconnect all peripheral cables from the server.

6. Do one of the following:
 - Extend the server out of the rack.
 - Remove the server from the rack.
7. Remove the access panel.
8. Remove the middle cover.
9. Disconnect following cables from the system board:
 - Optical drive SlimSAS-power Y-cable
 - Front USB and Display port cable
10. Remove the optical drive cage.

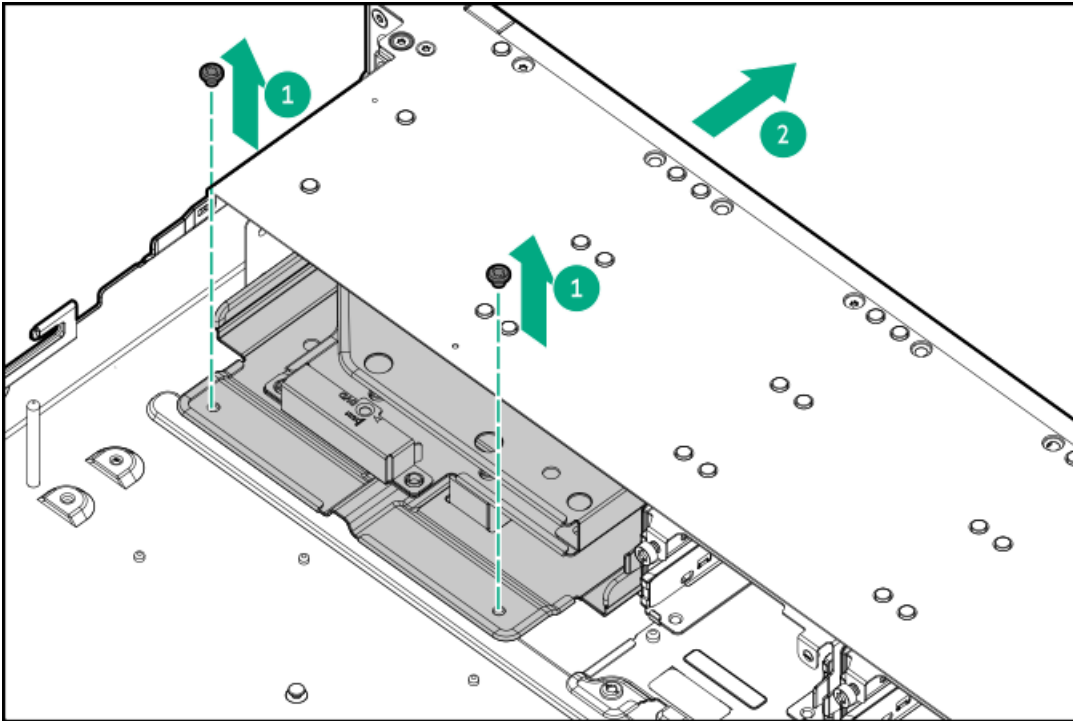

11. Remove the optical drive.

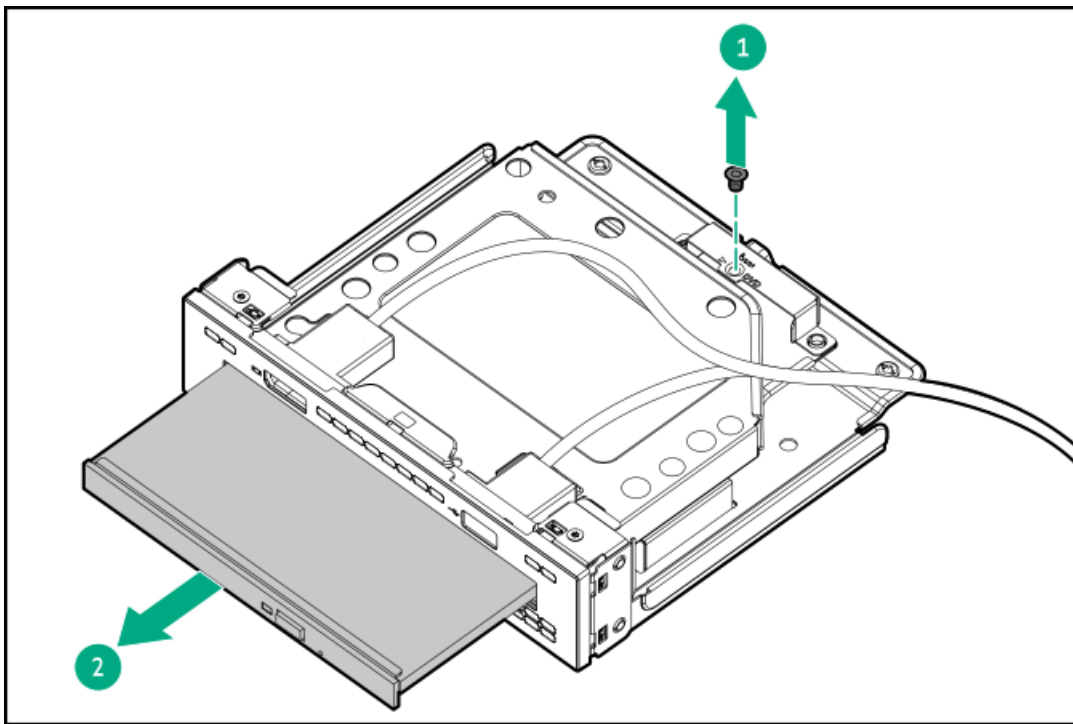

Results

The removal procedure is complete. To replace the component, reverse this procedure.

Removing and replacing the hood pin

Procedure

1. Power down the server.
2. Remove all power:
 - a. Disconnect each power cord from the power source.
 - b. Disconnect each power cord from the server.
3. Disconnect all peripheral cables from the server.
4. Do one of the following:
 - Remove the server from the rack.
 - Extend the server from the rack.
5. Remove the access panel.
6. Remove the middle cover.
7. Remove the fans.
8. Remove the hood pin.

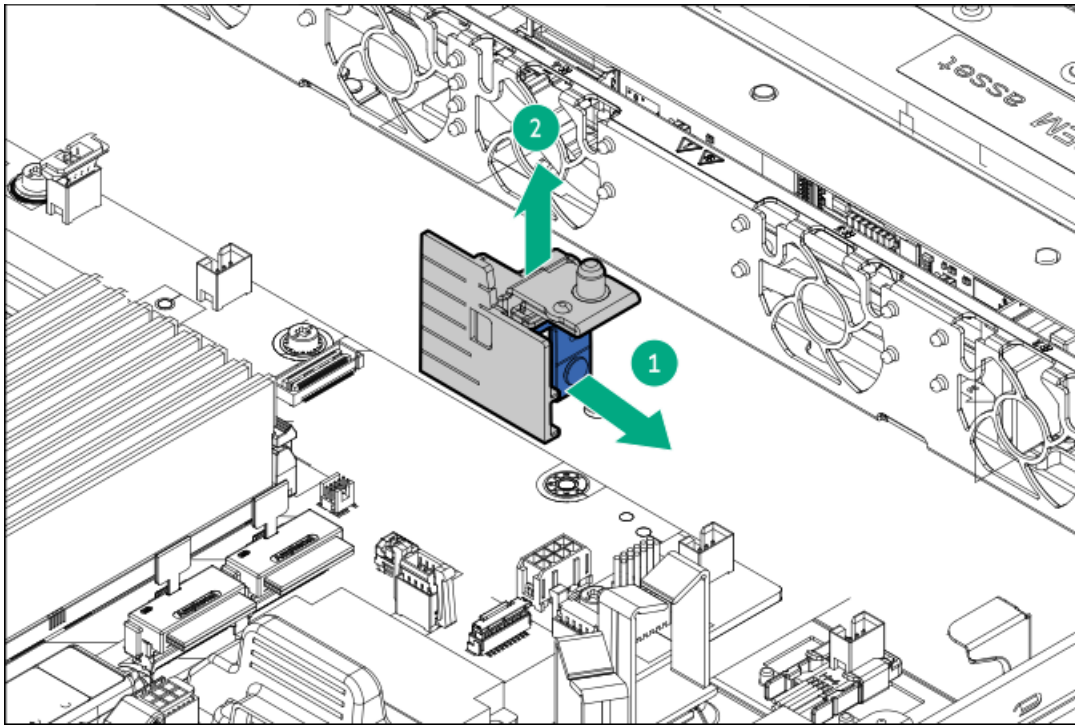

Results

The removal procedure is complete. To replace the component, reverse this procedure.

Removing and replacing a fan

About this task

https://sketchfab.com/models/a199310797f24c2f9cb5890bd4cc4a72/embed?ui_infos=0&ui_watermark=0&ui_help=0&ui_vr=0&ui_settings=0&ui_inspector=0&ui_hint=2&ui_color=01a982&ui_theme=dark&autostart=1&camera=0&



CAUTION

To prevent improper cooling and thermal damage, do not operate the server unless all bays are populated with either a component or a blank.



IMPORTANT

The fan setup can either be all seven of standard or high performance fans. Do not mix fan types in the same server.

Procedure

1. If installed, release the cable management arm.
2. Do one of the following:
 - Remove the server from the rack.
 - Extend the server out of the rack.
3. Remove the access panel.
4. Lift the fan out of the slot.
 - Standard and high performance fan

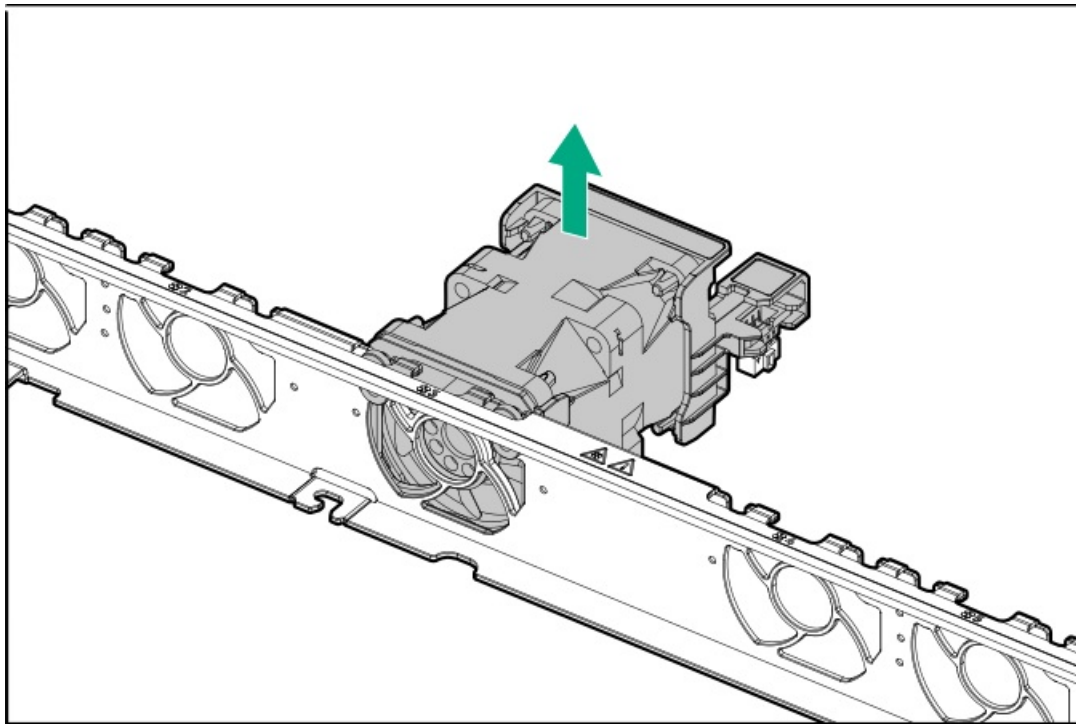

- Liquid cooling fan

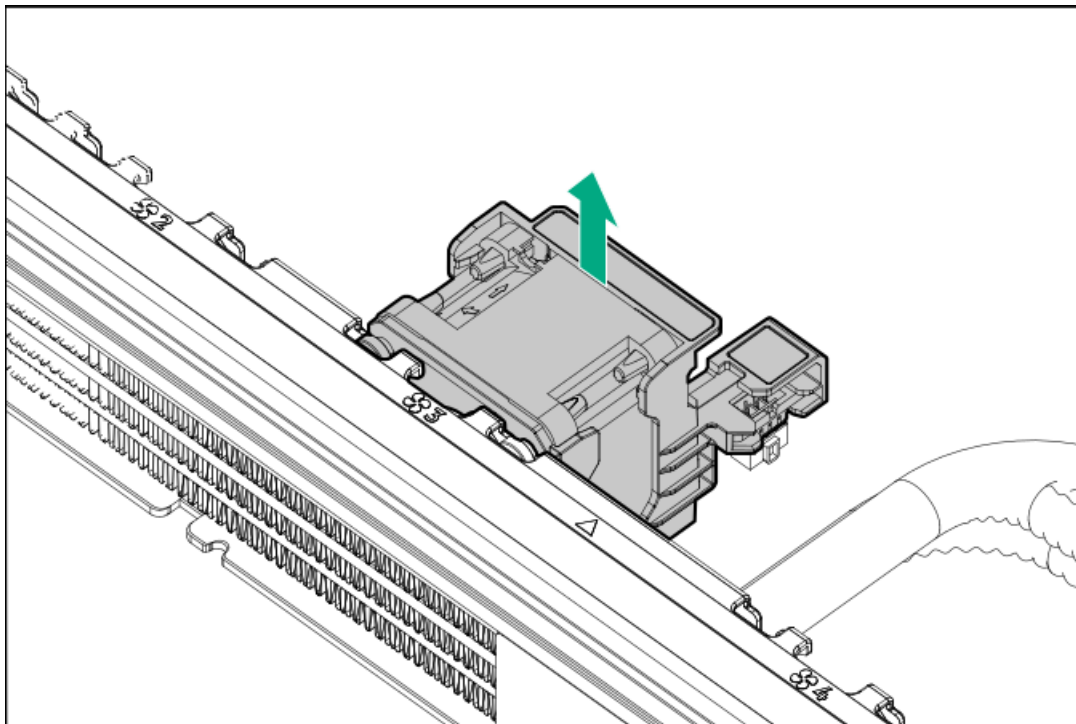

Results

The removal procedure is complete. To replace the component, reverse this procedure.

Removing and replacing a fan cable holder

About this task



CAUTION

To prevent improper cooling and thermal damage, do not operate the server unless all bays are populated with either a component or a blank.



IMPORTANT

The fan setup can either be all seven of standard or high performance fans. Do not mix fan types in the same server.

Procedure

1. Power down the server.
2. If installed, release the cable management arm.
3. Remove all power:
 - a. Disconnect each power cord from the power source.
 - b. Disconnect each power cord from the server.
4. Disconnect all peripheral cables from the server.
5. Remove the server from the rack.
6. Place the server on a flat, level work surface.
7. Remove the access panel.
8. Remove fan 2.
9. Remove the fan cable holder.

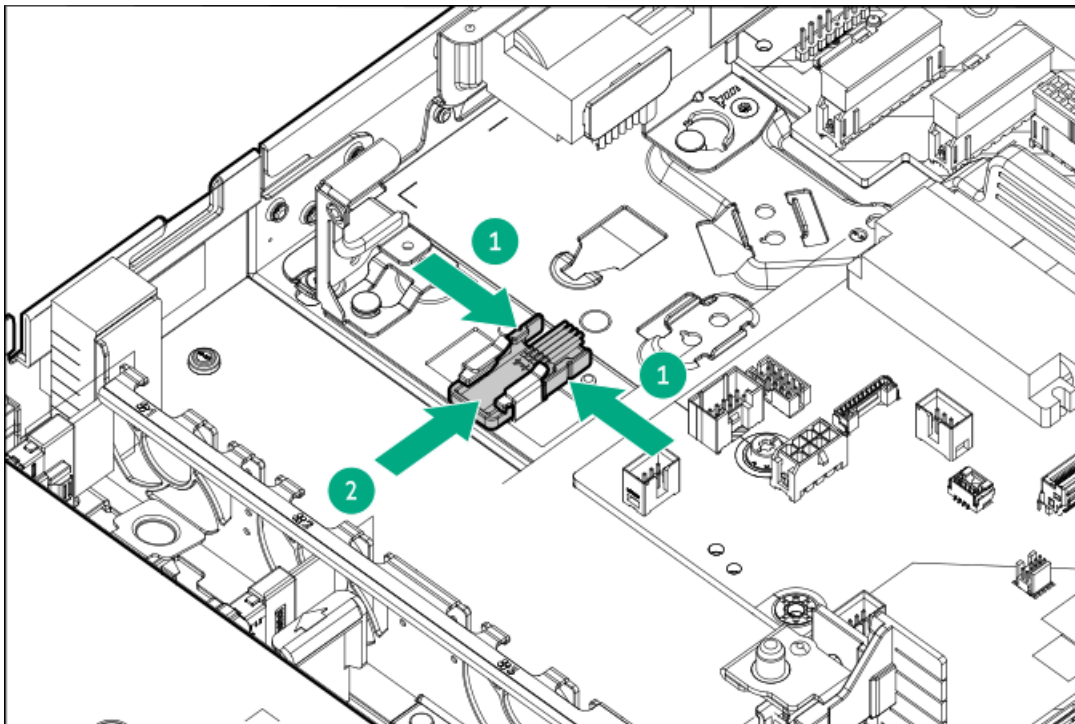

Results

The removal procedure is complete. To replace the component, reverse this procedure.

Removing and replacing a DIMM

About this task

https://sketchfab.com/models/ec39e4183f8f410e93c8c34a1611b560/embed?ui_infos=0&ui_watermark=0&ui_help=0&ui_vr=0&ui_settings=0&ui_inspector=0&ui_hint=2&ui_color=01a982&ui_theme=dark&autostart=1&camera=0&ui_animations=0



CAUTION

A discharge of static electricity from a finger or other conductor might damage system boards or other static-sensitive devices. To prevent damage, observe [antistatic precautions](#).



CAUTION

Before replacing a DIMM, backplane, expansion card, riser board, or other similar PCA components due to a perceived hardware error, make sure first that the component is firmly seated in the slot.

When installing the replacement component:

- Observe [antistatic precautions](#).
- Handle the PCA only along the edges.
- Do not touch the components and connectors on the PCA.
- Do not bend or flex the PCA.

Procedure

1. [Power down the server](#).
2. If installed, [release the cable management arm](#).
3. Remove all power:
 - a. Disconnect each power cord from the power source.
 - b. Disconnect each power cord from the server.
4. Disconnect all peripheral cables from the server.
5. Do one of the following:
 - a. [Extend the server from the rack](#).
 - b. [Remove the server from the rack](#).
6. [Remove the access panel](#).
7. Remove the DIMM.
 - a. Open the DIMM slot latches.
 - b. Lift the DIMM out of the slot.

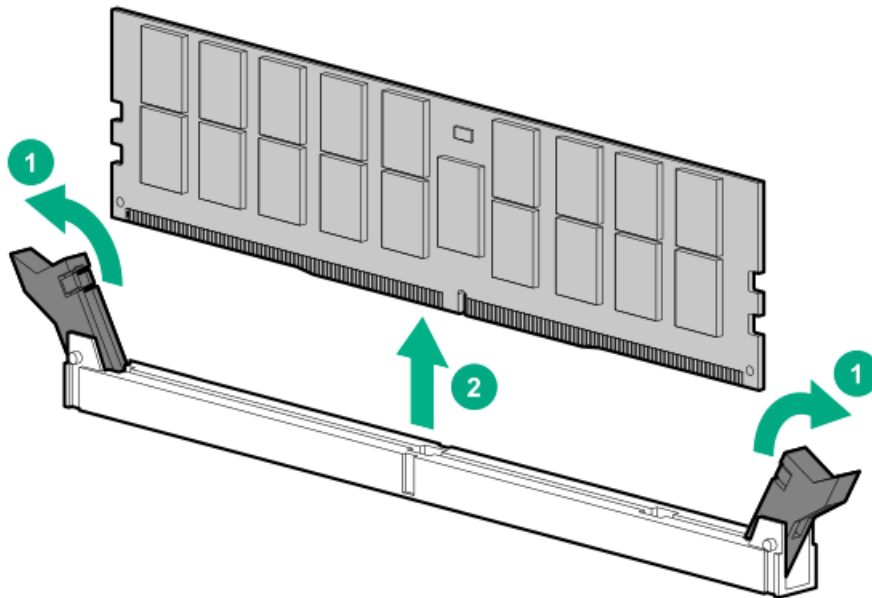

Results

The removal procedure is complete. To replace the component, reverse this procedure.

Removing and replacing a DIMM guard

Prerequisites

Before you perform this procedure, make sure that you have a T-15 Torx screwdriver available.

About this task



CAUTION

A discharge of static electricity from a finger or other conductor might damage system boards or other static-sensitive devices. To prevent damage, observe [antistatic precautions](#).

Procedure

1. [Power down the server](#).
2. If installed, [release the cable management arm](#).
3. Remove all power:
 - a. Disconnect each power cord from the power source.
 - b. Disconnect each power cord from the server.
4. Disconnect all peripheral cables from the server.
5. [Remove the server from the rack](#).
6. Place the server on a flat, level work surface.
7. [Remove the access panel](#).
8. Remove the DIMM guards.
 - Left:

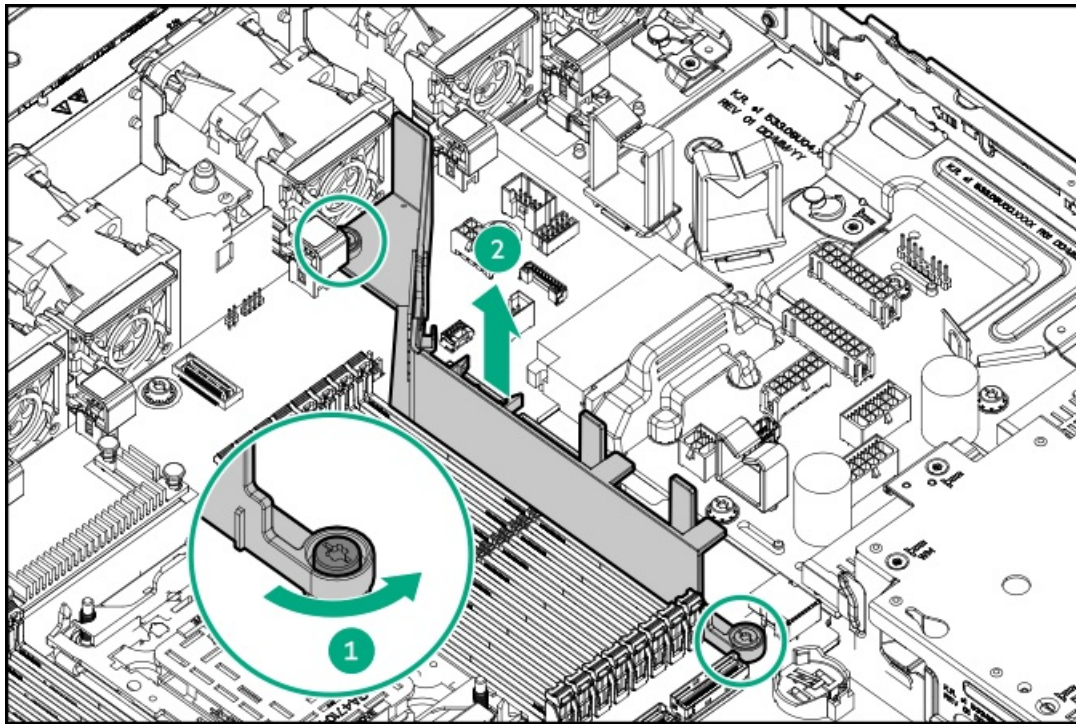

- Right:

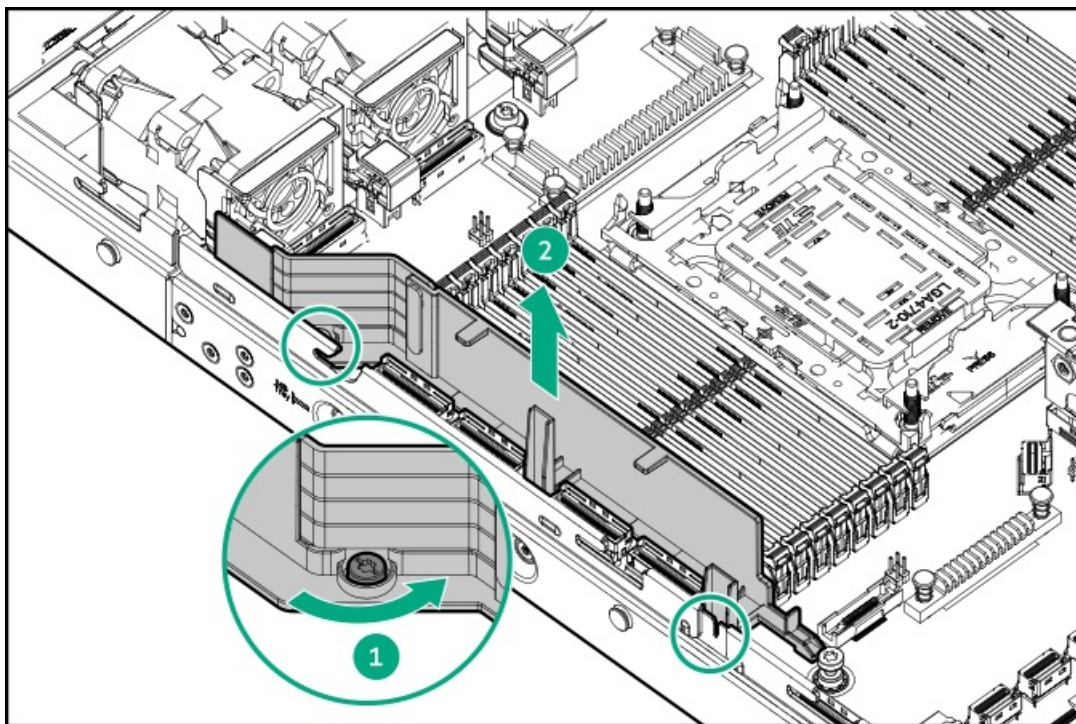

Results

The removal procedure is complete. To replace the component, reverse this procedure.

Removing and replacing the chassis intrusion detection switch

About this task



CAUTION

A discharge of static electricity from a finger or other conductor might damage system boards or other static-sensitive devices. To prevent damage, observe [antistatic precautions](#).

Procedure

1. [Power down the server](#).
2. If installed, [release the cable management arm](#).
3. Remove all power:
 - a. Disconnect each power cord from the power source.
 - b. Disconnect each power cord from the server.
4. Disconnect all peripheral cables from the server.
5. Do one of the following:
 - a. [Extend the server from the rack](#).
 - b. [Remove the server from the rack](#).
6. [Remove the access panel](#).
7. Remove the chassis intrusion detection switch:
 - a. Disconnect the cable.
 - b. Push the alignment pins to disengage the switch from the DIMM guard.
 - c. Remove the switch from the DIMM guard.

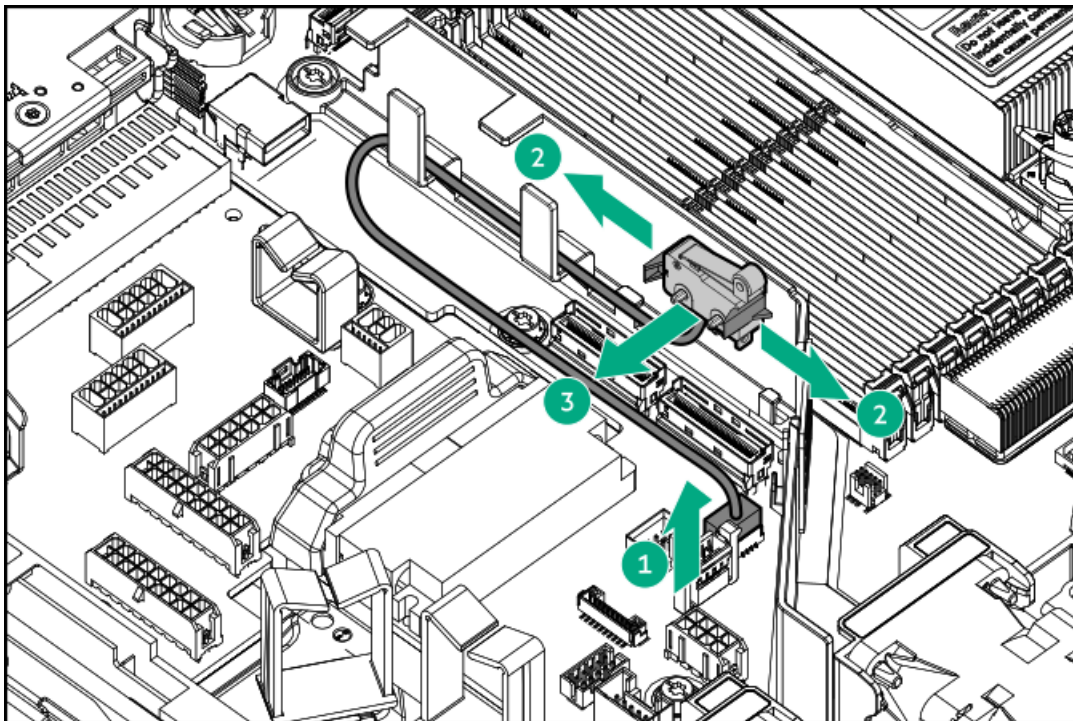

Results

To replace the component, reverse the removal procedure.

Removing and replacing the energy pack

Procedure

1. Power down the server.
2. If installed, release the cable management arm.
3. Remove all power:
 - a. Disconnect each power cord from the power source.
 - b. Disconnect each power cord from the server.
4. Disconnect all peripheral cables from the server.
5. Do one of the following:
 - Extend the server out of the rack.
 - Remove the server from the rack.
6. Remove the access panel.
7. Remove the energy pack.

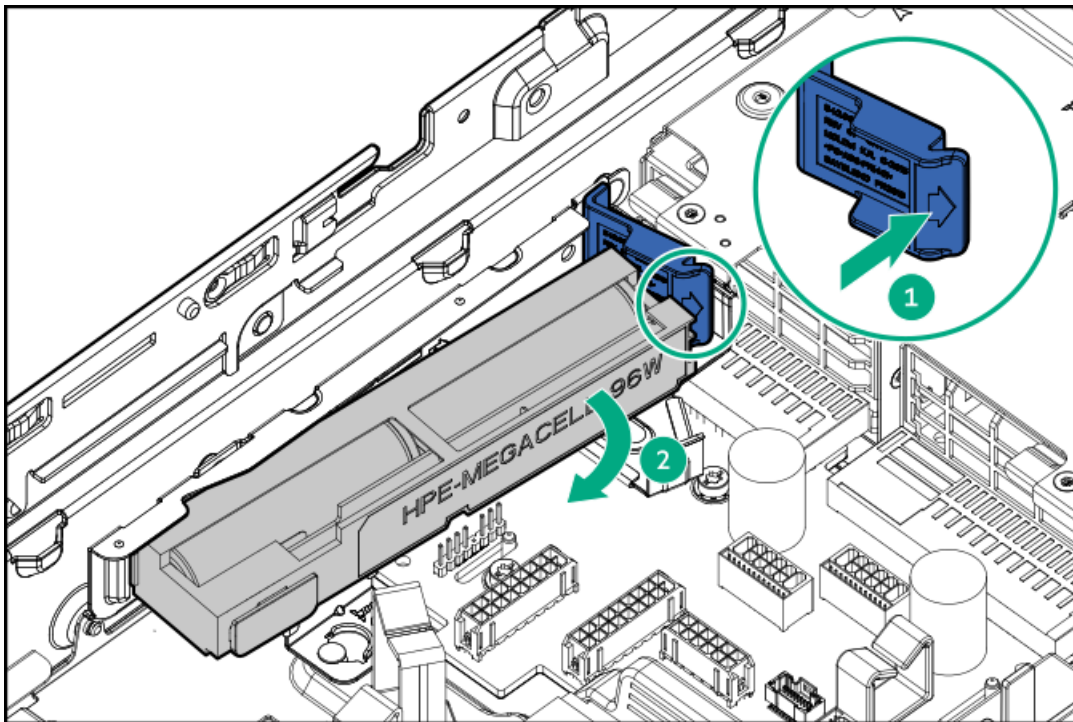

Results

The removal procedure is complete. To replace the component, reverse this procedure.

Removing and replacing the energy pack holder

Prerequisites

Before you perform this procedure, make sure that you have a T-10 Torx screwdriver available.

Procedure

1. Power down the server.
2. If installed, release the cable management arm.
3. Remove all power:
 - a. Disconnect each power cord from the power source.
 - b. Disconnect each power cord from the server.
4. Disconnect all peripheral cables from the server.
5. Do one of the following:
 - Extend the server out of the rack.
 - Remove the server from the rack.
6. Remove the access panel.
7. Disconnect the energy pack cable.
8. If installed, remove the energy pack.
9. Remove the energy pack holder.

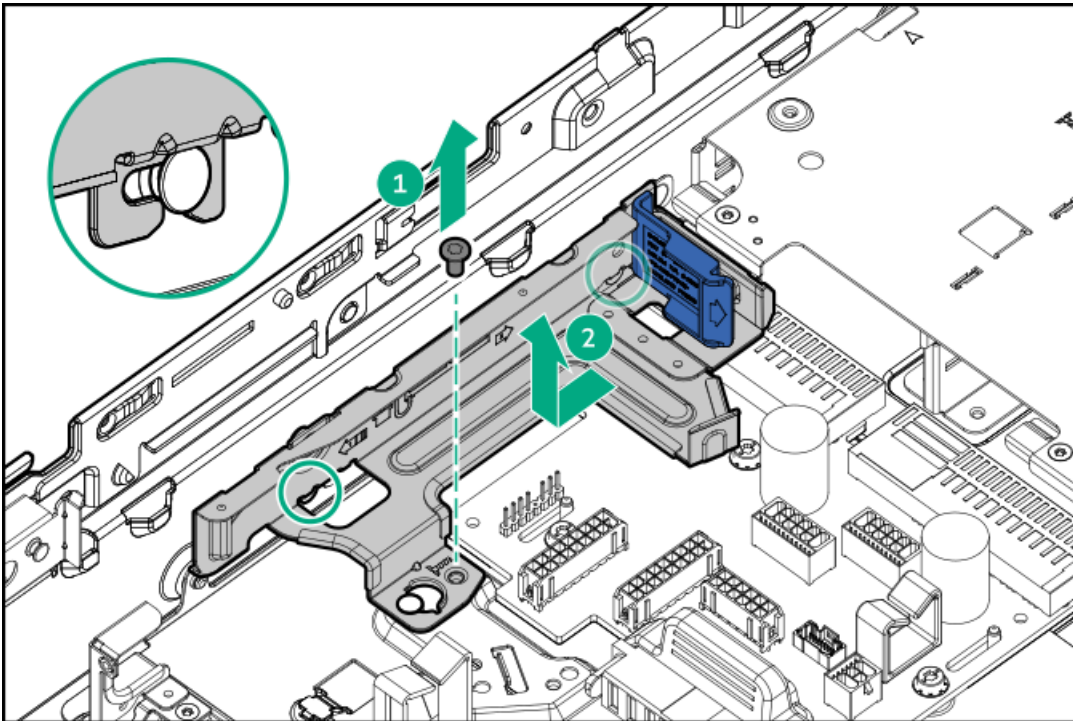

Results

The removal procedure is complete. To replace the component, reverse this procedure.

Removing and replacing an internal USB device

Procedure

1. Power down the server.
2. If installed, release the cable management arm.

3. Remove all power:
 - a. Disconnect each power cord from the power source.
 - b. Disconnect each power cord from the server.
4. Disconnect all peripheral cables from the server.
5. Do one of the following:
 - a. Extend the server from the rack.
 - b. Remove the server from the rack.
6. Remove the access panel.
7. Unplug the USB device from the USB port.

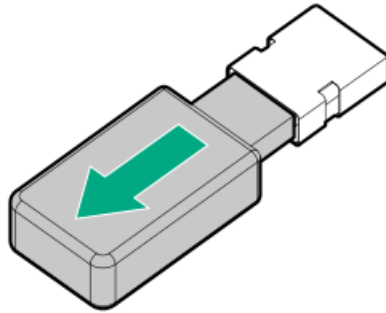

Results

The removal procedure is complete. To replace the component, reverse this procedure.

Removing and replacing the power distribution board

Prerequisites

Before you perform this procedure, make sure that you have a T-15 Torx screwdriver available.

About this task

https://sketchfab.com/models/2eb80884a8cd4bf3ae4c2a2874335ff4/embed?ui_infos=0&ui_watermark=0&ui_help=0&ui_vr=0&ui_settings=0&ui_inspector=0&ui_hint=2&ui_color=01a982&ui_theme=dark&autostart=1&camera=0&



CAUTION

Before replacing a DIMM, backplane, expansion card, riser board, or other similar PCA components due to a perceived hardware error, make sure first that the component is firmly seated in the slot.

When installing the replacement component:

- Observe antistatic precautions.
- Handle the PCA only along the edges.
- Do not touch the components and connectors on the PCA.
- Do not bend or flex the PCA.

Procedure

1. Power down the server.
2. If installed, release the cable management arm.
3. Remove all power:
 - a. Disconnect each power cord from the power source.
 - b. Disconnect each power cord from the server.
4. Disconnect all peripheral cables from the server.
5. Remove the server from the rack.
6. Place the server on a flat, level work surface.
7. Remove the access panel.
8. Remove all of the following components:
 - HPE NS204i-u Boot Device V2
 - Power supplies
 - Serial port bracket
 - Energy pack bracket
9. Disconnect all cables from the power distribution board (PDB).
10. Remove the PDB:
 - a. Remove the screws.
 - b. Push the board to disengage it from the system board.
 - c. Lift the board from the chassis.

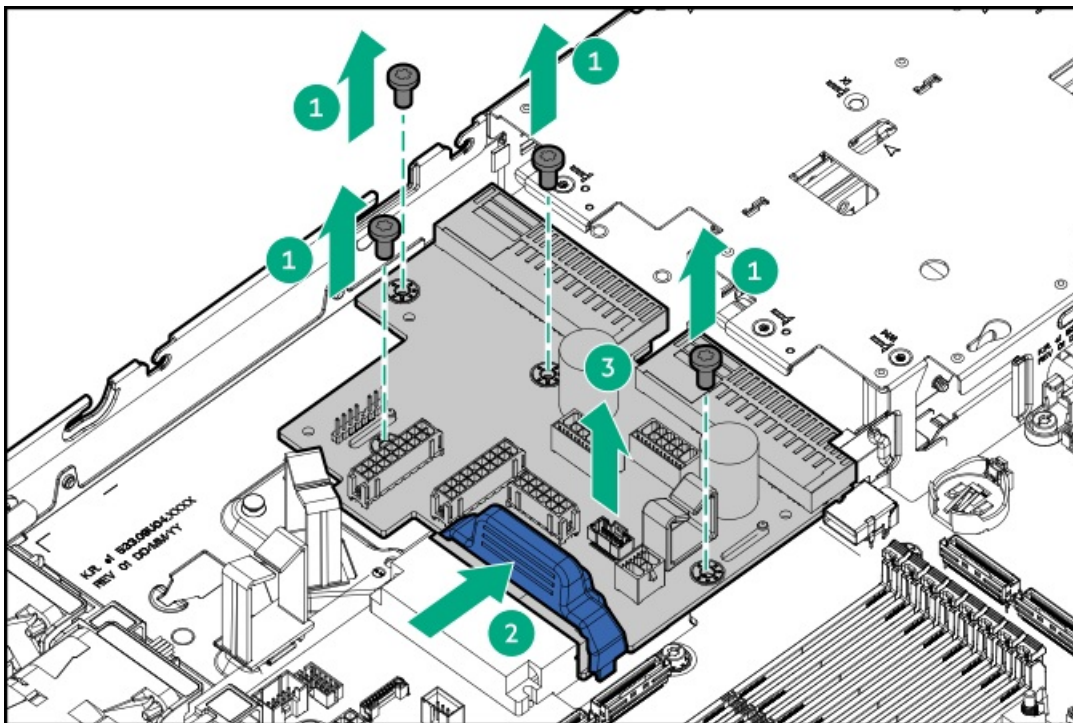

Results

The removal procedure is complete. To replace the component, reverse this procedure.

System battery replacement

If the server no longer automatically displays the correct date and time, then replace the battery that provides power to the real-time clock. Under normal use, battery life is 5–10 years.

Subtopics

[System battery information](#)

[Removing and replacing the system battery](#)

System battery information

The server contains an internal lithium manganese dioxide, a vanadium pentoxide, or an alkaline battery that provides power to the real-time clock.



WARNING

If this battery is not properly handled, a risk of fire or burning exists. To reduce the risk of personal injury:

- Do not attempt to recharge the battery.
- Do not expose the battery to temperatures higher than 60°C (140°F).
- Do not expose the battery to low air pressure as it might lead to explosion or leakage of flammable liquid or gas.
- Do not disassemble, crush, puncture, short external contacts, or dispose of the battery in fire or water.

Removing and replacing the system battery

Prerequisites

Before you perform this procedure, make sure that you have a spudger or any small prying tool available.

About this task

https://sketchfab.com/models/6f2a2a1a5c8540cb9a3adc740b055e0e/embed?ui_infos=0&ui_watermark=0&ui_help=0&ui_vr=0&ui_settings=0&ui_inspector=0&ui_hint=2&ui_color=01a982&ui_theme=dark&autostart=1&camera=0&ui_animations=0



IMPORTANT

After replacing the system battery and applying power, wait for 10 minutes before powering on the server. This lead time is required for the server to reset and reinitialize the iLO configuration settings stored in SRAM.



CAUTION

A discharge of static electricity from a finger or other conductor might damage system boards or other static-sensitive devices. To prevent damage, observe [antistatic precautions](#).

Procedure

1. [Power down the server](#).

2. If installed, release the cable management arm.
3. Remove all power:
 - a. Disconnect each power cord from the power source.
 - b. Disconnect each power cord from the server.
4. Disconnect all peripheral cables from the server.
5. Remove the server from the rack.
6. Place the server on a flat, level work surface.
7. Remove the access panel.
8. Remove the system battery:
 - a. Use a small flat-bladed, nonconductive tool to press the battery latch.
 - b. Remove the system battery from the socket.

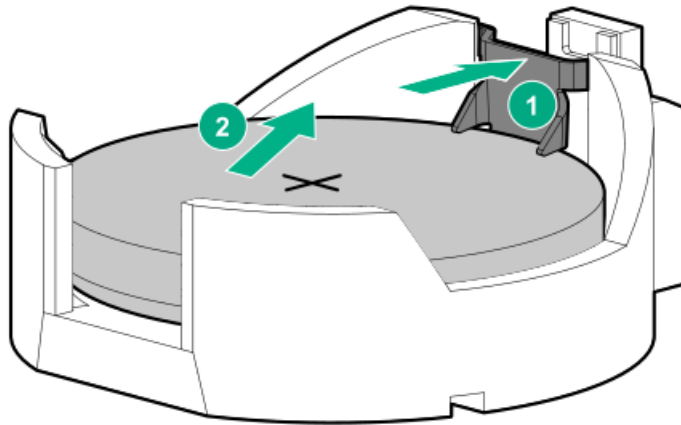

9. Install the system battery:
 - a. With the side of the battery showing the "+" sign facing up, insert the battery into the socket.
 - b. Press the system battery down until it clicks into place.

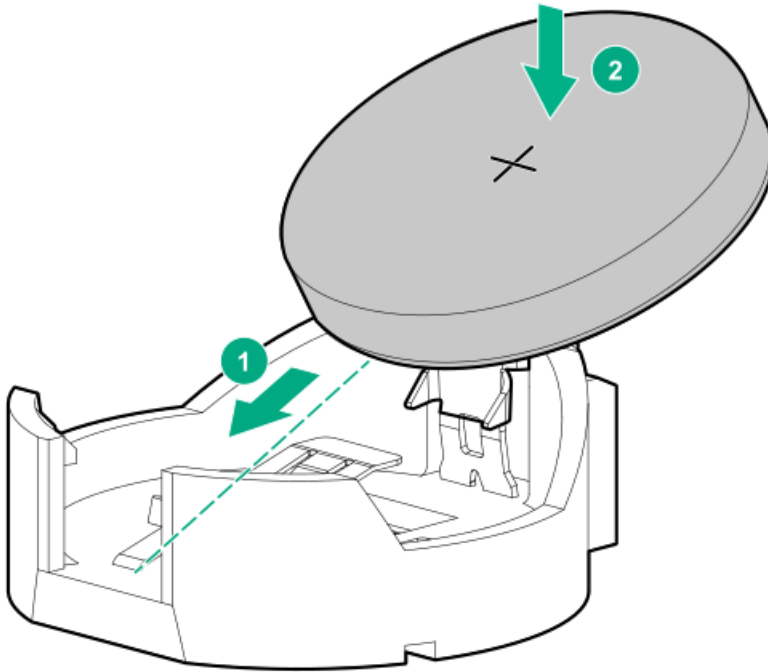

10. Wait for 10 minutes for the server to reset, and then reinitialize the iLO configuration settings stored in SRAM.



IMPORTANT

If iLO security is disabled, the configuration will not be restored. To restore the configuration manually, see <https://www.hpe.com/support/hpeilodocs-quicklinks>.

11. Properly dispose of the old battery.

For more information about proper battery disposal, contact an authorized reseller or an authorized service provider.

Results

The removal procedure is complete. To replace the component, reverse this procedure.

Expansion card replacement

Subtopics

[Removing and replacing a type-o storage controller](#)

[Removing and replacing a type-p storage controller](#)

[Removing and replacing an expansion card](#)

Removing and replacing a type-o storage controller

About this task



CAUTION

Before replacing a DIMM, backplane, expansion card, riser board, or other similar PCA components due to a perceived hardware error, make sure first that the component is firmly seated in the slot.

When installing the replacement component:

- Observe antistatic precautions.
- Handle the PCA only along the edges.
- Do not touch the components and connectors on the PCA.
- Do not bend or flex the PCA.



CAUTION

To prevent improper cooling and thermal damage, do not operate the server unless all OCP slots have either an OCP option or a slot blank installed.

Procedure

1. Power down the server.
2. If installed, release the cable management arm.
3. Remove all power:
 - a. Disconnect each power cord from the power source.
 - b. Disconnect each power cord from the server.
4. Disconnect all peripheral cables from the server.
5. Do one of the following:
 - Extend the server out of the rack.
 - Remove the server from the rack.
6. Remove the access panel.
7. Remove the riser cage.
8. Remove the type-o storage controller.
 - a. Pivot the locking pin to the open (vertical) position.
 - b. Remove the controller from the slot.

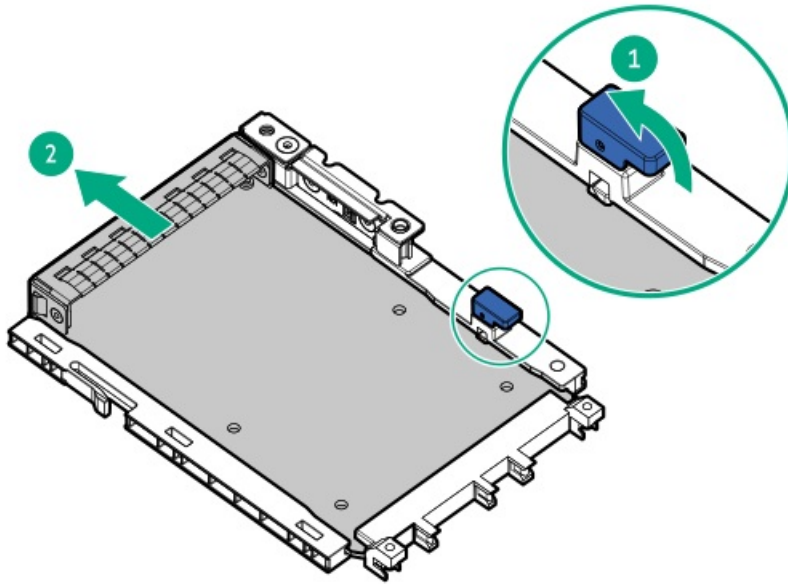

Results

The removal procedure is complete. To replace the component, reverse this procedure.

Removing and replacing a type-p storage controller

Prerequisites

Before you perform this procedure, make sure that you have a T-10 Torx screwdriver available.

About this task



CAUTION

Before replacing a DIMM, backplane, expansion card, riser board, or other similar PCA components due to a perceived hardware error, make sure first that the component is firmly seated in the slot.

When installing the replacement component:

- Observe antistatic precautions.
- Handle the PCA only along the edges.
- Do not touch the components and connectors on the PCA.
- Do not bend or flex the PCA.



CAUTION

To prevent improper cooling and thermal damage, do not operate the server unless all PCIe slots have either a riser slot blank or an expansion card installed.

Procedure

1. Power down the server.

2. If installed, release the cable management arm.
3. Remove all power:
 - a. Disconnect each power cord from the power source.
 - b. Disconnect each power cord from the server.
4. Disconnect all peripheral cables from the server.
5. Do one of the following:
 - Extend the server out of the rack.
 - Remove the server from the rack.
6. Remove the access panel.
7. Disconnect the storage controller cables from the system board.
8. Remove the riser cage.
9. Disconnect any internal cables that are connected to the expansion card.
10. Remove the type-p storage controller.

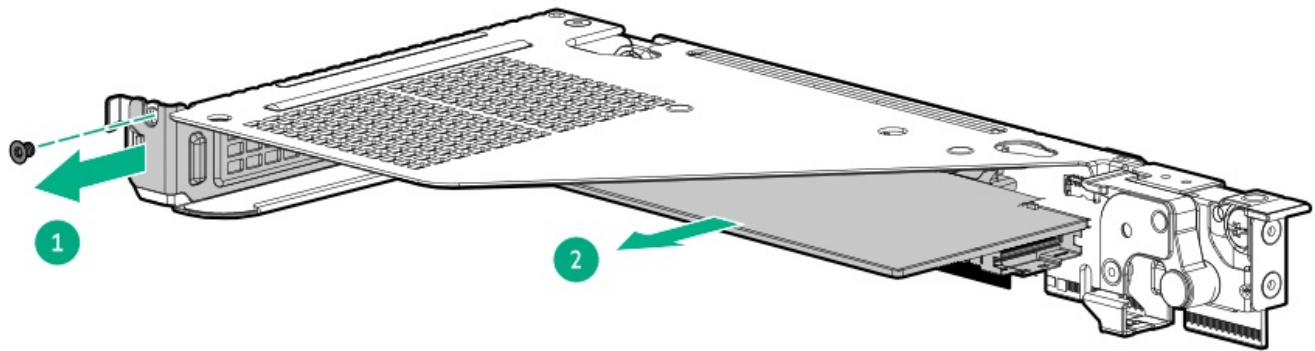

Results

The removal procedure is complete. To replace the component, reverse this procedure.

Removing and replacing an expansion card

Prerequisites

Before you perform this procedure, make sure that you have a T-10 Torx screwdriver available.

About this task

https://sketchfab.com/models/502caea13ba94e2d86375ea40191c743/embed?ui_infos=0&ui_watermark=0&ui_help=0&ui_vr=0&ui_settings=0&ui_inspector=0&ui_hint=2&ui_color=01a982&ui_theme=dark&autostart=1&camera=0&



CAUTION

A discharge of static electricity from a finger or other conductor might damage system boards or other static-sensitive devices. To prevent damage, observe antistatic precautions.



CAUTION

To prevent improper cooling and thermal damage, do not operate the server unless all PCIe slots have either a riser slot blank or an expansion card installed.



CAUTION

Before replacing a DIMM, backplane, expansion card, riser board, or other similar PCA components due to a perceived hardware error, make sure first that the component is firmly seated in the slot.

When installing the replacement component:

- Observe antistatic precautions.
- Handle the PCA only along the edges.
- Do not touch the components and connectors on the PCA.
- Do not bend or flex the PCA.

Procedure

1. Power down the server.
2. If installed, release the cable management arm.
3. Remove all power:
 - a. Disconnect each power cord from the power source.
 - b. Disconnect each power cord from the server.
4. Disconnect all peripheral cables from the server.
5. Remove the server from the rack.
6. Place the server on a flat, level work surface.
7. Remove the access panel.
8. Disconnect all cables connected to the expansion card.
9. Remove the riser cage.
10. Remove the expansion card.
 - a. Remove the screw.
 - b. Detach the expansion card from the riser.

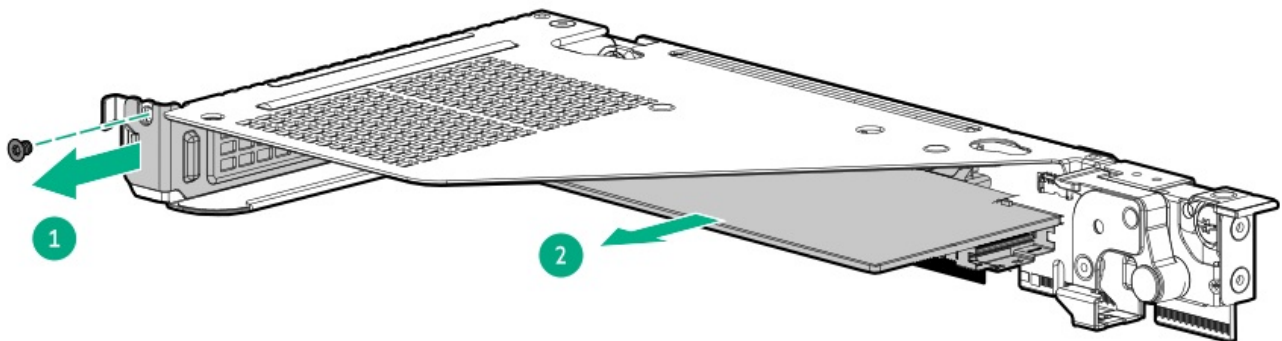

Results

The removal procedure is complete. To replace the component, reverse this procedure.

Removing and replacing a riser cage blank

Prerequisites

Before you perform this procedure, make sure that you have a T-10 Torx screwdriver available.

About this task

The removal procedure for a full-height riser cage blank and a low-profile riser cage blank is the same.

Procedure

1. Power down the server.
2. Remove all power:
 - a. Disconnect each power cord from the power source.
 - b. Disconnect each power cord from the server.
3. Disconnect all peripheral cables from the server.
4. Remove the server from the rack.
5. Place the server on a flat, level work surface.
6. Remove the access panel.
7. Remove the screw, and then lift the riser cage blank.

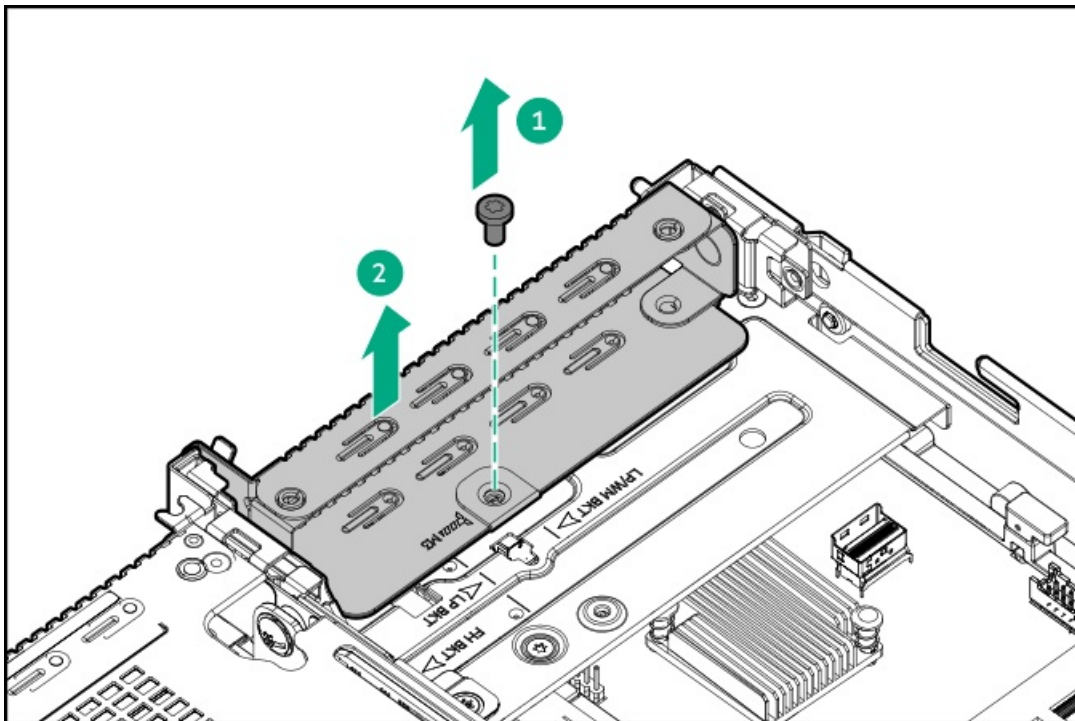

Riser board replacement

Subtopics

- [Removing and replacing a riser board](#)
- [Removing and replacing the GPU captive riser](#)

Removing and replacing a riser board

Prerequisites

Before you perform this procedure, make sure that you have a T-15 Torx screwdriver available.

About this task

https://sketchfab.com/models/2eb21ea7ca8d49b6a9e2abdf3a2675dd/embed?ui_infos=0&ui_watermark=0&ui_help=0&ui_vr=0&ui_settings=0&ui_inspector=0&ui_hint=2&ui_color=01a982&ui_theme=dark&autostart=1&camera=0&



CAUTION

A discharge of static electricity from a finger or other conductor might damage system boards or other static-sensitive devices. To prevent damage, observe [antistatic precautions](#).



CAUTION

Before replacing a DIMM, backplane, expansion card, riser board, or other similar PCA components due to a perceived hardware error, make sure first that the component is firmly seated in the slot.

When installing the replacement component:

- Observe [antistatic precautions](#).
- Handle the PCA only along the edges.
- Do not touch the components and connectors on the PCA.
- Do not bend or flex the PCA.

Procedure

1. [Power down the server](#).
2. If installed, [release the cable management arm](#).
3. Remove all power:
 - a. Disconnect each power cord from the power source.
 - b. Disconnect each power cord from the server.
4. Disconnect all peripheral cables from the server.
5. [Remove the server from the rack](#).
6. Place the server on a flat, level work surface.
7. [Remove the access panel](#).
8. [Remove the riser cage](#).
9. If installed, [remove any expansion card from the riser](#).
10. Remove the riser board.

Retain all screws for future use.

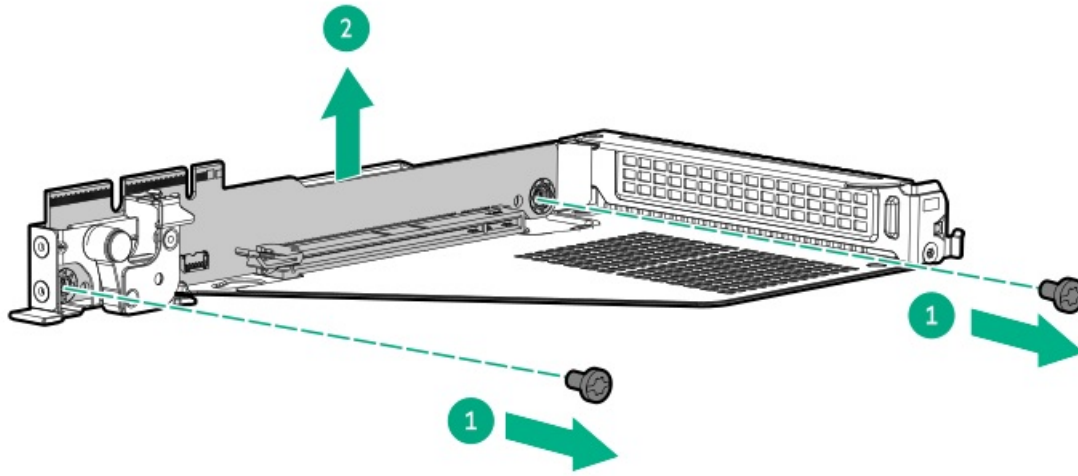

Results

The removal procedure is complete. To replace the component, reverse this procedure.

Removing and replacing the GPU captive riser

Prerequisites

Before you perform this procedure, make sure that you have the following items available:

- T-10 Torx screwdriver
- T-15 Torx screwdriver

About this task

https://sketchfab.com/models/cfa057d855544ecd81e470146d7fea24/embed?ui_infos=0&ui_watermark=0&ui_help=0&ui_vr=0&ui_settings=0&ui_inspector=0&ui_hint=2&ui_color=01a982&ui_theme=dark&autostart=1&camera=0&



CAUTION

A discharge of static electricity from a finger or other conductor might damage system boards or other static-sensitive devices. To prevent damage, observe [antistatic precautions](#).



CAUTION

Before replacing a DIMM, backplane, expansion card, riser board, or other similar PCA components due to a perceived hardware error, make sure first that the component is firmly seated in the slot.

When installing the replacement component:

- Observe [antistatic precautions](#).
- Handle the PCA only along the edges.
- Do not touch the components and connectors on the PCA.
- Do not bend or flex the PCA.

Procedure

1. [Power down the server](#).

2. If installed, remove the front bezel.
3. If installed, open the cable management arm.
4. Remove all power:
 - a. Disconnect each power cord from the power source.
 - b. Disconnect each power cord from the server.
5. Disconnect all peripheral cables from the server.
6. Remove the server from the rack.
7. Place the server on a flat, level work surface.
8. Remove the access panel.
9. Remove the middle cover.
10. Disconnect the captive riser cables.
11. Remove the GPU riser cage.
12. Remove the cable holder.

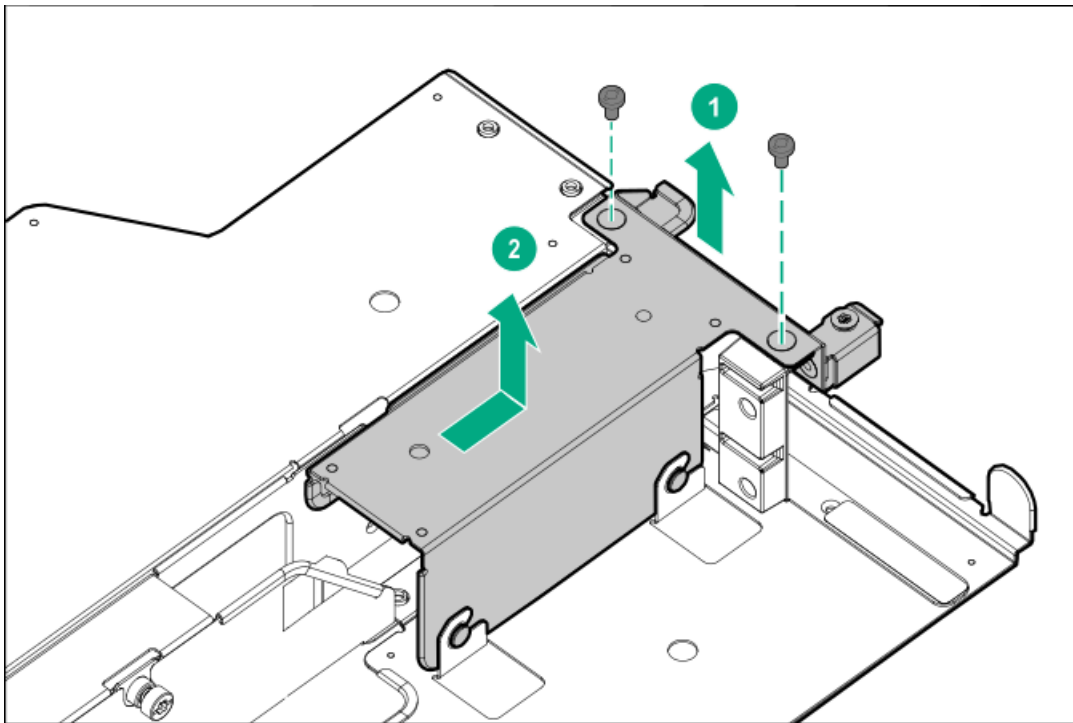

13. Remove the screws, and then slide the captive riser out of the slot.

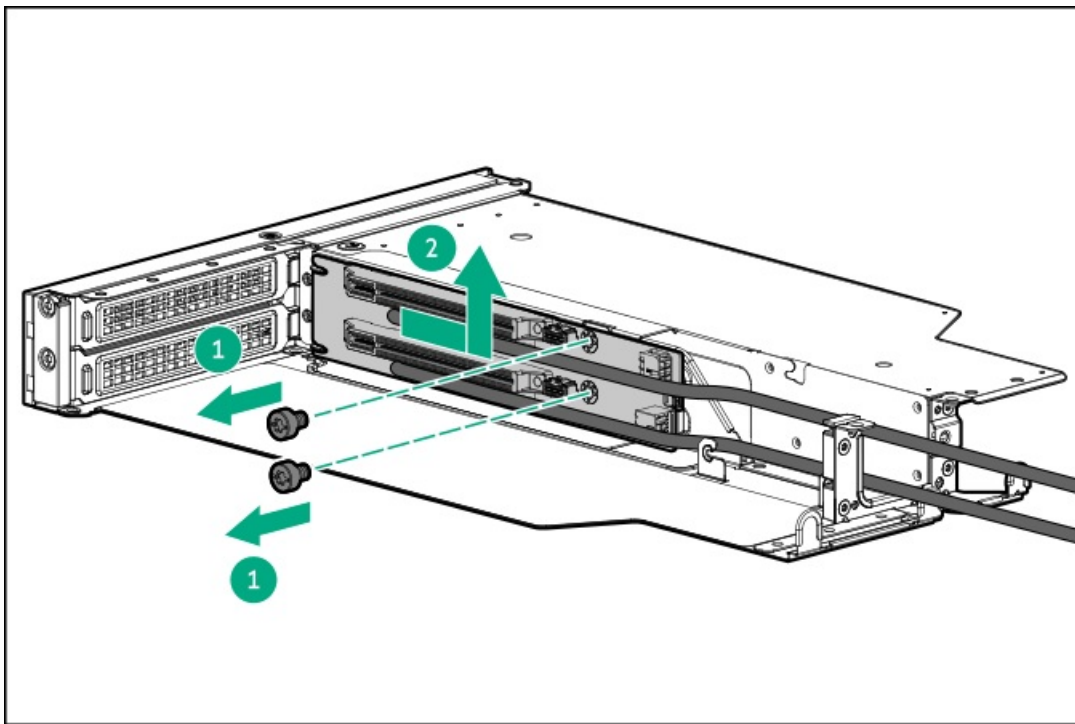

Results

The removal procedure is complete. To replace the component, reverse this procedure.

GPU replacement

Subtopics

[Removing and replacing a GPU from the GPU cage](#)

[Removing and replacing a GPU](#)

Removing and replacing a GPU from the GPU cage

Prerequisites

Before you perform this procedure, make sure that you have a T-15 Torx screwdriver available.

About this task



CAUTION

Before replacing a DIMM, backplane, expansion card, riser board, or other similar PCA components due to a perceived hardware error, make sure first that the component is firmly seated in the slot.

When installing the replacement component:

- Observe [antistatic precautions](#).
- Handle the PCA only along the edges.
- Do not touch the components and connectors on the PCA.
- Do not bend or flex the PCA.



CAUTION

To prevent improper cooling and thermal damage, do not operate the server unless all PCIe slots have either a riser slot blank or an expansion card installed.

Procedure

1. Back up all server data.
2. Power down the server.
3. If installed, release the cable management arm.
4. Remove all power:
 - a. Disconnect each power cord from the power source.
 - b. Disconnect each power cord from the server.
5. Disconnect all peripheral cables from the server.
6. Remove the server from the rack.
7. Place the server on a flat, level work surface.
8. Remove the access panel.
9. Remove the middle cover.
10. Disconnect the GPU auxiliary power cable.
11. Remove the GPU riser cage.
12. Remove the GPU.
 - a. Loosen the captive screws on the GPU bracket retainer.
 - b. Remove the GPU bracket retainer.
 - c. Remove the GPU.
 - Single-width:

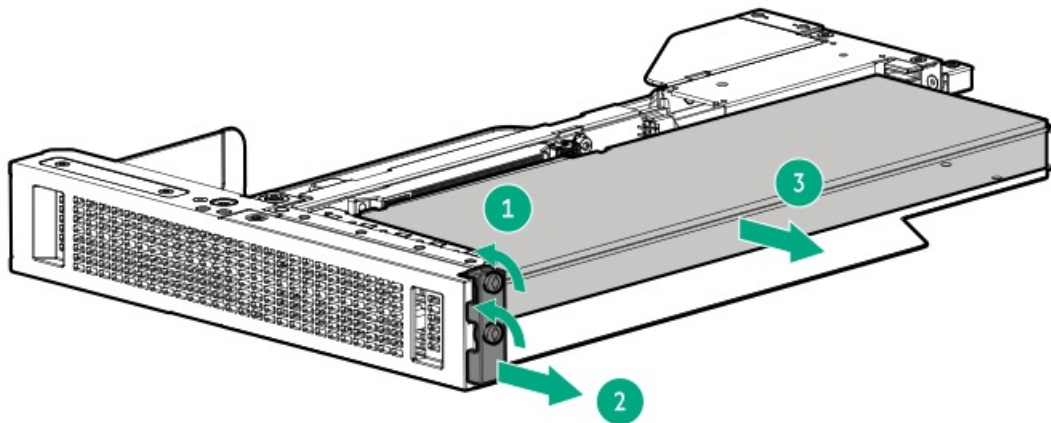

- Double-width:

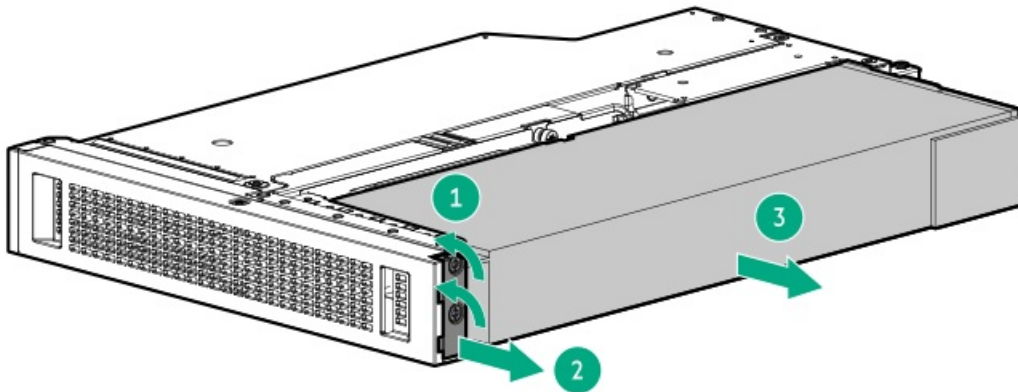

Results

The removal procedure is complete. To replace the component, reverse this procedure.

Removing and replacing a GPU

Prerequisites

Before you perform this procedure, make sure that you have a T-10 Torx screwdriver available.

About this task



CAUTION

A discharge of static electricity from a finger or other conductor might damage system boards or other static-sensitive devices. To prevent damage, observe [antistatic precautions](#).



CAUTION

Before replacing a DIMM, backplane, expansion card, riser board, or other similar PCA components due to a perceived hardware error, make sure first that the component is firmly seated in the slot.

When installing the replacement component:

- Observe [antistatic precautions](#).
- Handle the PCA only along the edges.
- Do not touch the components and connectors on the PCA.
- Do not bend or flex the PCA.

Procedure

1. Back up all server data.
2. Power down the server.
3. If installed, release the cable management arm.
4. Remove all power:
 - a. Disconnect each power cord from the power source.
 - b. Disconnect each power cord from the server.
5. Disconnect all peripheral cables from the server.
6. Remove the server from the rack.
7. Place the server on a flat, level work surface.
8. Remove the access panel.
9. Remove the riser cage.
10. Remove the existing rear guide bracket from the GPU, if installed.
11. Remove the GPU from the riser cage.

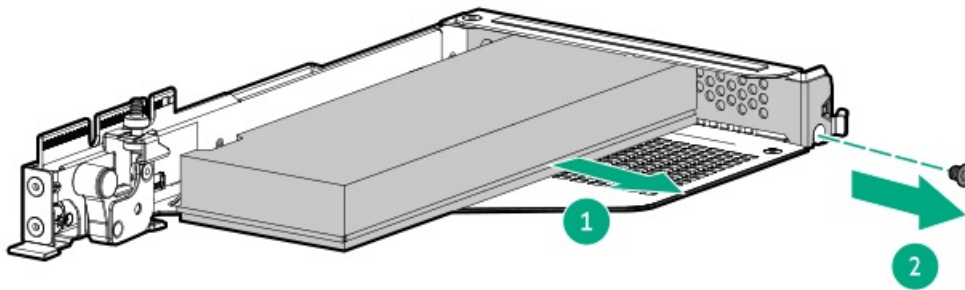

Results

The removal procedure is complete. To replace the component, reverse this procedure.

Removing and replacing an OCP adapter

About this task

https://sketchfab.com/models/ac02ab5a52f140faa5c7e7a4444f9683/embed?ui_infos=0&ui_watermark=0&ui_help=0&ui_vr=0&ui_settings=0&ui_inspector=0&ui_hint=2&ui_color=01a982&ui_theme=dark&autostart=1&camera=0&ui_animations=0



CAUTION

A discharge of static electricity from a finger or other conductor might damage system boards or other static-sensitive devices. To prevent damage, observe antistatic precautions.



CAUTION

Before replacing a DIMM, backplane, expansion card, riser board, or other similar PCA components due to a perceived hardware error, make sure first that the component is firmly seated in the slot.

When installing the replacement component:

- Observe antistatic precautions.
- Handle the PCA only along the edges.
- Do not touch the components and connectors on the PCA.
- Do not bend or flex the PCA.

Procedure

1. Power down the server.
2. If installed, release the cable management arm.
3. Remove all power:
 - a. Disconnect each power cord from the power source.
 - b. Disconnect each power cord from the server.
4. Disconnect all peripheral cables from the server.
5. Remove the server from the rack.
6. Place the server on a flat, level work surface.
7. Remove the access panel.
8. Remove the riser cage.
9. Remove the OCP NIC 3.0 adapter.
 - a. Rotate the locking pin to the open (vertical) position.
 - b. Pull the OCP 3.0 NIC adapter out of the slot.

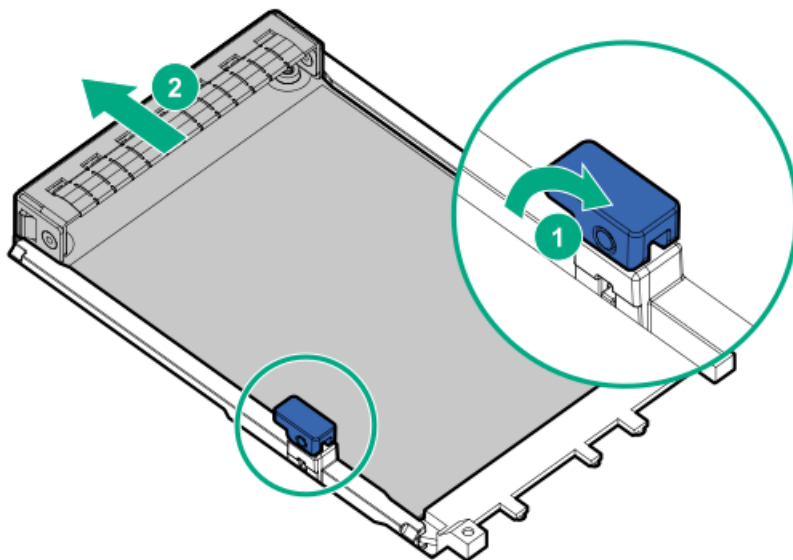

Results

The removal procedure is complete. To replace the component, reverse this procedure.

DC-SCM replacement

Subtopics

[Removing the DC-SCM](#)

[Installing the DC-SCM](#)

Removing the DC-SCM

About this task

https://sketchfab.com/models/c24a054a02b54f46be9e9c6d2ea10a83/embed?ui_infos=0&ui_watermark=0&ui_help=0&ui_vr=0&ui_settings=0&ui_inspector=0&ui_hint=2&ui_color=01a982&ui_theme=dark&autostart=1&camera=0&ui_animations=0



CAUTION

A discharge of static electricity from a finger or other conductor might damage system boards or other static-sensitive devices. To prevent damage, observe [antistatic precautions](#).



CAUTION

The port blank provides EMI shielding and helps maintain proper thermal status inside the server. Do not operate the server when a port blank is removed without the corresponding I/O port option installed.



CAUTION

Before replacing a DIMM, backplane, expansion card, riser board, or other similar PCA components due to a perceived hardware error, make sure first that the component is firmly seated in the slot.

When installing the replacement component:

- Observe [antistatic precautions](#).
- Handle the PCA only along the edges.
- Do not touch the components and connectors on the PCA.
- Do not bend or flex the PCA.

Procedure

1. [Power down the server](#).
2. [Release the cable management arm](#).
3. Remove all power:
 - a. Disconnect each power cord from the power source.
 - b. Disconnect each power cord from the server.
4. Disconnect all peripheral cables from the server.
5. [Remove the server from the rack](#).
6. Place the server on a flat, level work surface.
7. [Remove the access panel](#).

8. Remove the primary riser cage.
9. If connected, disconnect the ix cable.
10. Remove the DC-SCM:
 - a. Pivot the locking pin to the open (vertical) position.
 - b. Push the blue touchpoint to disengage the module from the slot.
 - c. Remove the module from the slot.

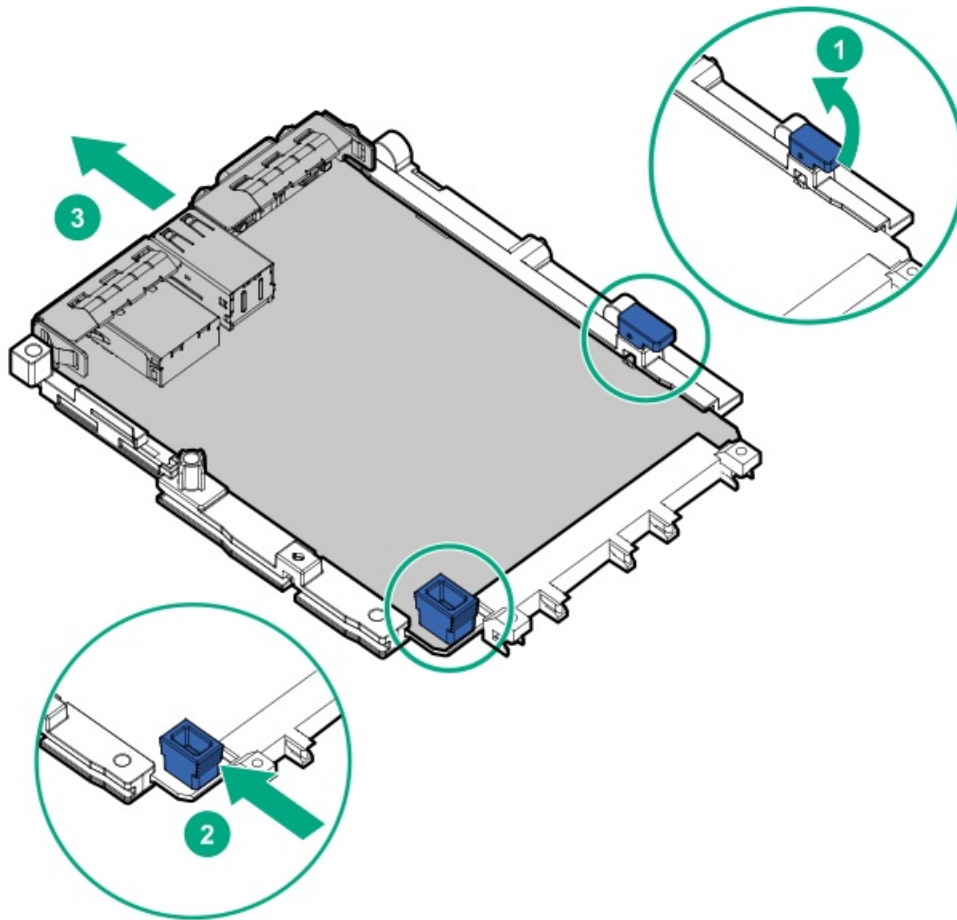

Installing the DC-SCM

Prerequisites

Before you perform this procedure, make sure that you have the iLO login credentials from the toe tag that shipped with the new DC-SCM spare. Use these credentials to bind the new DC-SCM with the existing system board.

About this task



CAUTION

Before replacing a DIMM, backplane, expansion card, riser board, or other similar PCA components due to a perceived hardware error, make sure first that the component is firmly seated in the slot.

When installing the replacement component:

- Observe antistatic precautions.
- Handle the PCA only along the edges.
- Do not touch the components and connectors on the PCA.
- Do not bend or flex the PCA.

Procedure

1. Install the DC-SCM:
 - a. Rotate the locking pin to the open (vertical) position.
 - b. Slide the module into the slot until it clicks into place. Make sure that the module is seated firmly in the slot.
 - c. Rotate the locking pin to the close (horizontal) position.

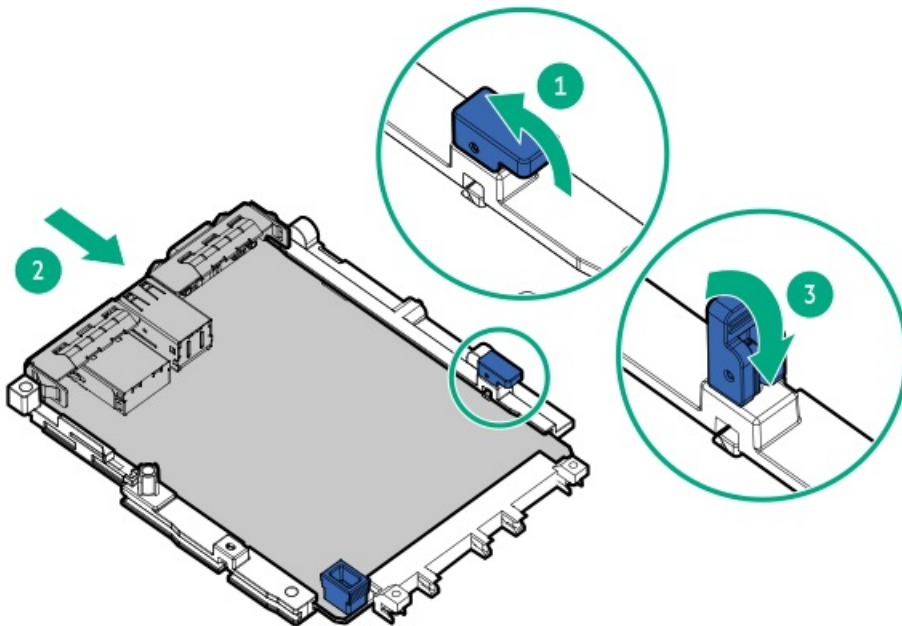

2. Install the primary riser cage.
3. If disconnected, connect the ix port cable.
4. Install the access panel.
5. Install the server into the rack.
6. Connect all peripheral cables to the server.
7. Connect each power cord to the server.
8. Connect each power cord to the power source.
9. Power up the server.
10. Bind the DC-SCM with the system board using one of the following tools:

- [iLO web interface](#)
- [iLO RESTful API](#)
- [UEFI System Utilities](#)

Results

The replacement procedure is complete.

Removing and replacing the ix port cable bracket

Prerequisites

Before you perform this procedure, make sure that you have the following items available:

- Phillips No. 1 screwdriver
- T-10 Torx screwdriver

About this task



CAUTION

A discharge of static electricity from a finger or other conductor might damage system boards or other static-sensitive devices. To prevent damage, observe [antistatic precautions](#).



CAUTION

The port blank provides EMI shielding and helps maintain proper thermal status inside the server. Do not operate the server when a port blank is removed without the corresponding I/O port option installed.

Procedure

1. [Power down the server.](#)
2. If installed, [release the cable management arm.](#)
3. Remove all power:
 - a. Disconnect each power cord from the power source.
 - b. Disconnect each power cord from the server.
4. Disconnect all peripheral cables from the server.
5. [Remove the server from the rack.](#)
6. Place the server on a flat, level work surface.
7. [Remove the access panel.](#)
8. [Remove the power supply.](#)
9. [Disconnect the ix port cable from the DC-SCM.](#)
10. Remove the ix port cable bracket.
 - 60 mm power supply configuration:

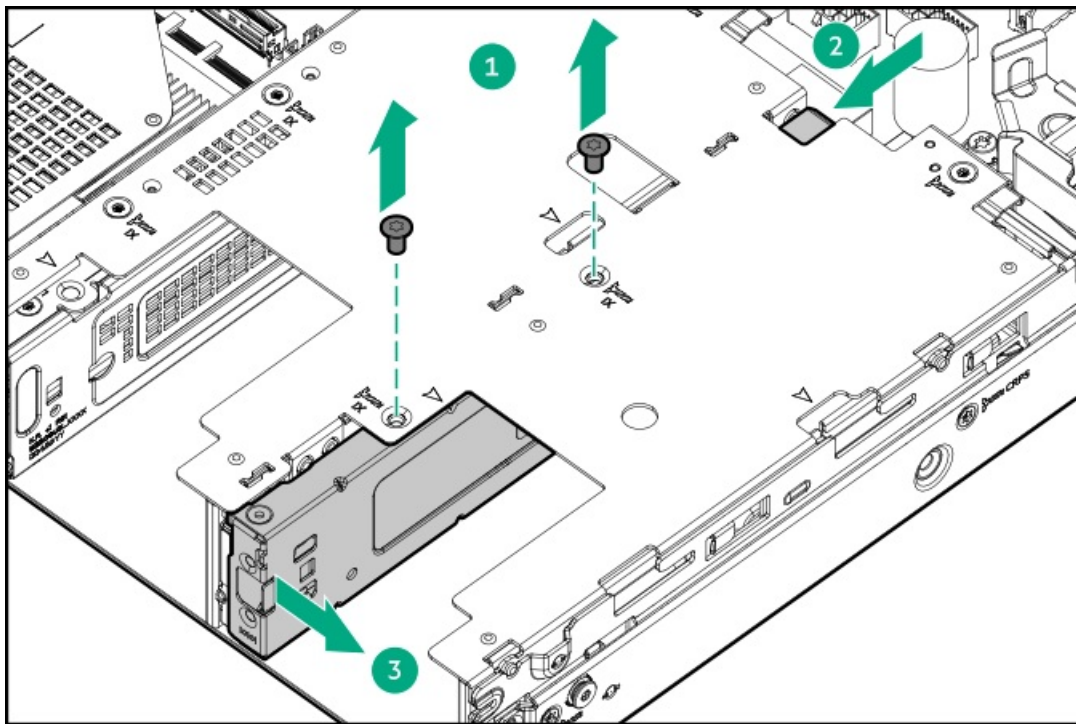

- 73.5 mm power supply configuration:

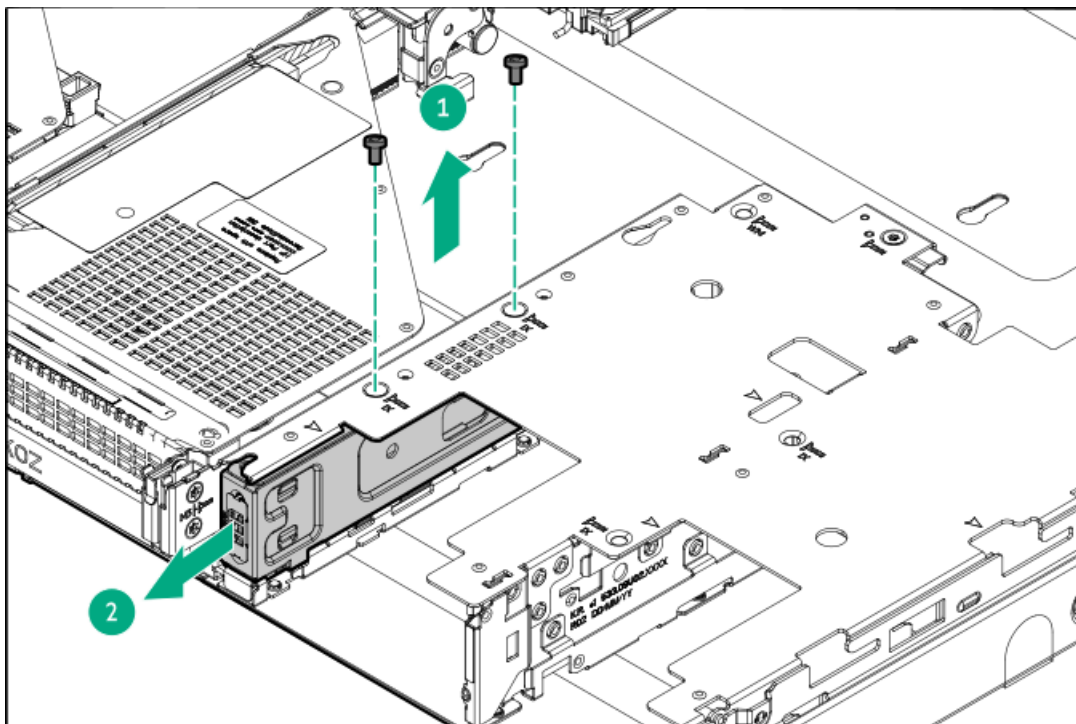

Results

The removal procedure is complete. To replace the component, reverse this procedure.

Removing and replacing a serial port/ix port cable

Prerequisites

Before you perform this procedure, make sure that you have a hex screwdriver available.

About this task



CAUTION

A discharge of static electricity from a finger or other conductor might damage system boards or other static-sensitive devices. To prevent damage, observe [antistatic precautions](#).



CAUTION

The port blank provides EMI shielding and helps maintain proper thermal status inside the server. Do not operate the server when a port blank is removed without the corresponding I/O port option installed.

Procedure

1. [Power down the server](#).
2. If installed, [release the cable management arm](#).
3. Remove all power:
 - a. Disconnect each power cord from the power source.
 - b. Disconnect each power cord from the server.
4. Disconnect all peripheral cables from the server.
5. [Remove the server from the rack](#).
6. Place the server on a flat, level work surface.
7. [Remove the access panel](#).
8. [Remove the power supply](#).
9. [Disconnect the ix port cable from the DC-SCM](#).
10. [Remove the ix port cable bracket](#).
11. Remove the ix port cable.
 - 60-mm M-CRPS

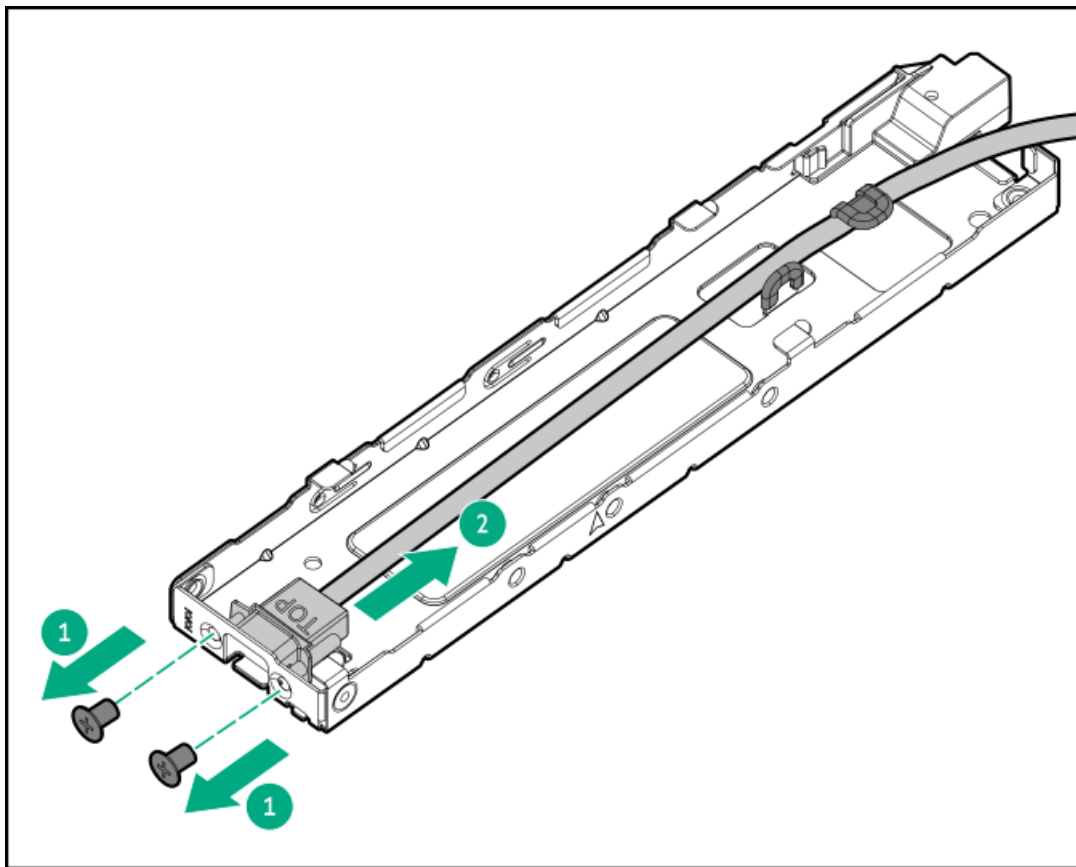

- 73.5-mm M-CRPS

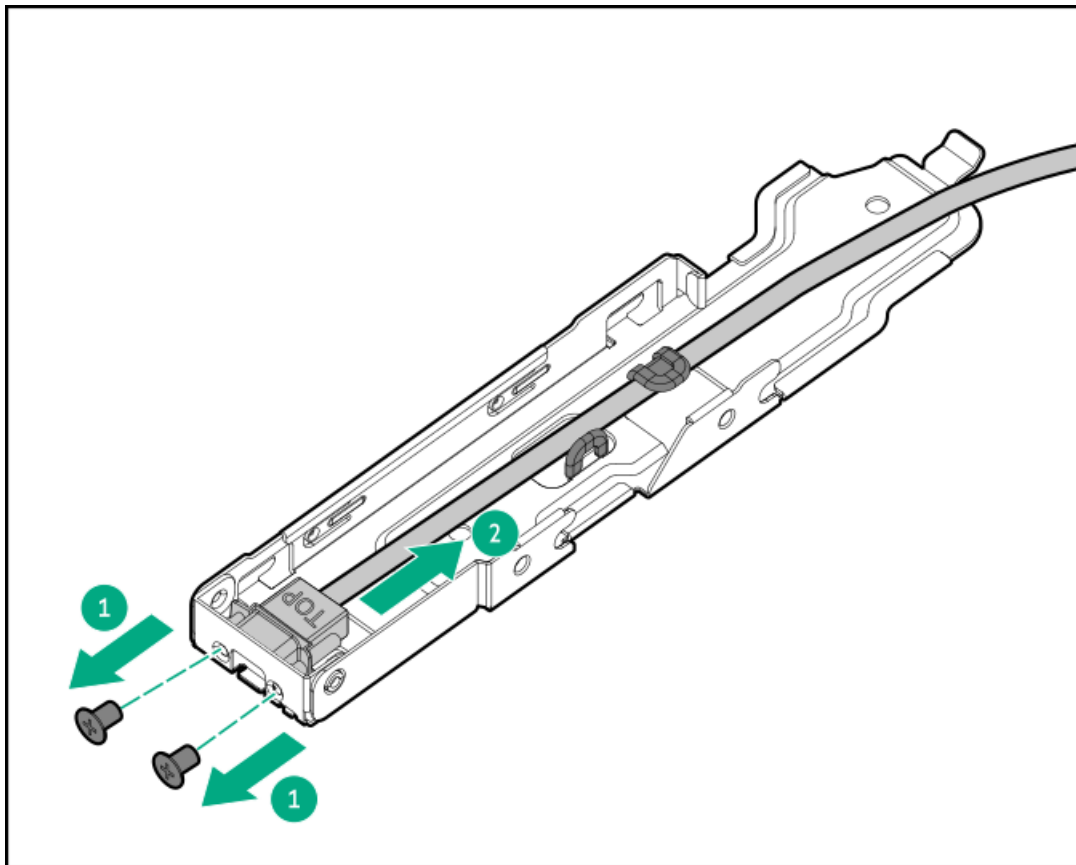

Results

The removal procedure is complete. To replace the component, reverse this procedure.

Make sure that the ix port cable is secured in the tabs on the bracket after replacement.

Removing and replacing the ix port blank

Prerequisites

Before you perform this procedure, make sure that you have the following items available:

- T-10 Torx screwdriver
- Spudger or any small prying tool

About this task



CAUTION

A discharge of static electricity from a finger or other conductor might damage system boards or other static-sensitive devices. To prevent damage, observe [antistatic precautions](#).



CAUTION

The port blank provides EMI shielding and helps maintain proper thermal status inside the server. Do not operate the server when a port blank is removed without the corresponding I/O port option installed.

Procedure

1. [Power down the server](#).
2. If installed, [release the cable management arm](#).
3. Remove all power:
 - a. Disconnect each power cord from the power source.
 - b. Disconnect each power cord from the server.
4. Disconnect all peripheral cables from the server.
5. Do one of the following:
 - [Extend the server out of the rack](#).
 - [Remove the server from the rack](#).
6. [Remove the access panel](#).
7. Do one of the following:
 - [Remove the power supply blank](#).
 - [Remove the power supply](#).
8. [Remove the power supply cage filler](#).
9. [Remove the ix port cable bracket](#).
10. Remove the ix port blank.

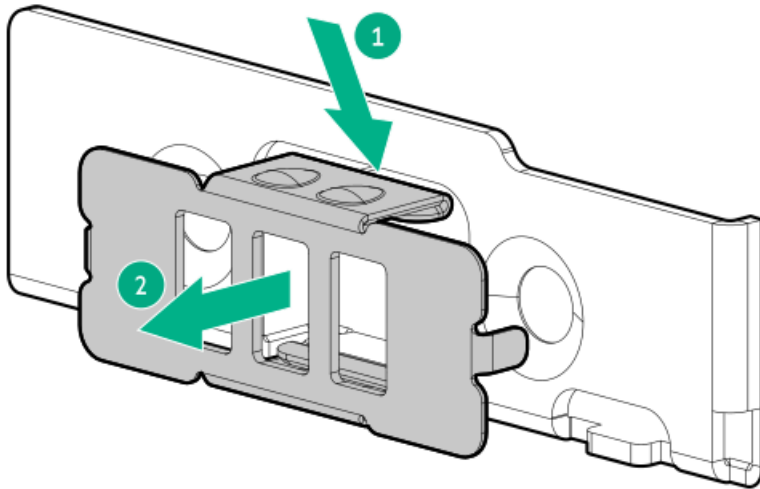

Results

The removal procedure is complete. To replace the component, reverse this procedure.

Removing and replacing the HPE NS204i-u Boot Device V2 bracket

Prerequisites

Before you perform this procedure, make sure that you have a T-10 Torx screwdriver available.

About this task



CAUTION

To prevent improper cooling and thermal damage, do not operate the server unless all bays are populated with either a component or a blank.



CAUTION

A discharge of static electricity from a finger or other conductor might damage system boards or other static-sensitive devices. To prevent damage, observe [antistatic precautions](#).

Procedure

1. [Power down the server.](#)
2. If installed, [release the cable management arm.](#)
3. Remove all power:
 - a. Disconnect each power cord from the power source.
 - b. Disconnect each power cord from the server.
4. Disconnect all peripheral cables from the server.
5. [Remove the server from the rack.](#)
6. Place the server on a flat, level work surface.
7. [Remove the access panel.](#)
8. [Remove the power supply cage filler.](#)

9. Do one of the following:
 - Remove the power supply blank from bay 2.
 - Remove the power supply from bay 2.
10. Disconnect the HPE NS204i-u Boot Device V2 power and signal cables from the system board.
11. Remove the boot device cage.
12. If installed, remove the boot device cage assembly from the bracket.

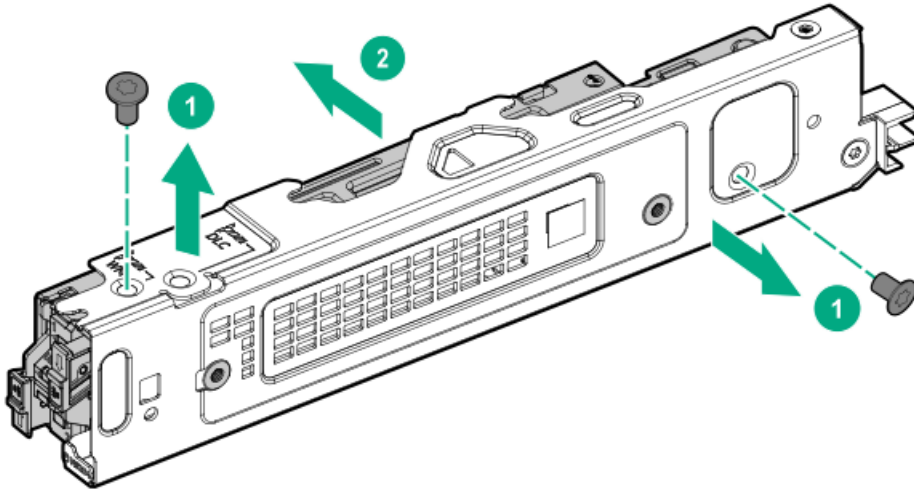

13. Remove the security cover.

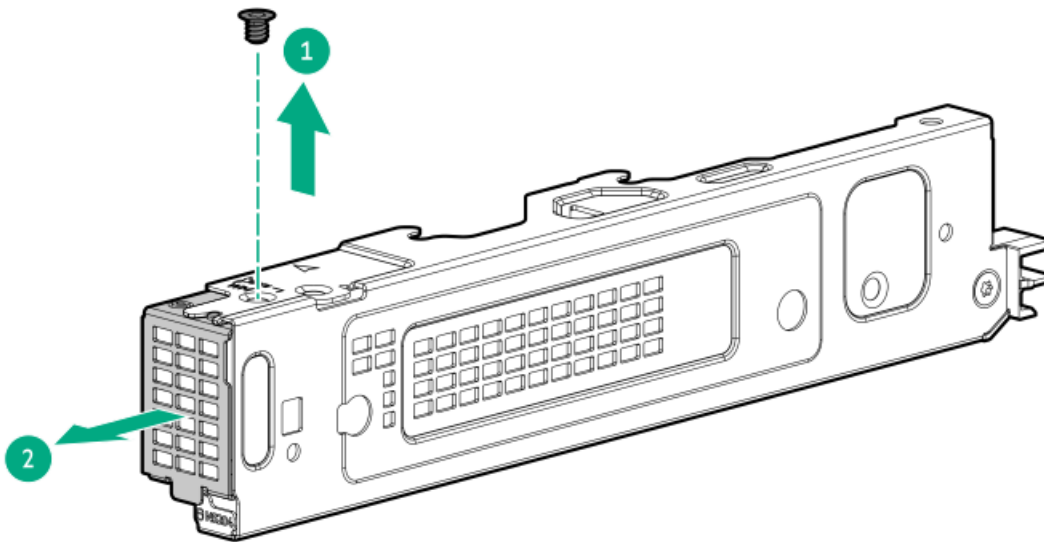

Results

The removal procedure is complete. To replace the component, reverse this procedure.

HPE NS204i-u Boot Device V2 replacement

Subtopics

[Removing and replacing the HPE NS204i-u Boot Device V2 from Box 3](#)

[Removing and replacing the HPE NS204i-u Boot Device V2 from the chassis](#)

[Removing and replacing HPE NS204i-u Boot Device V2 from the rear of the chassis](#)

[Removing and replacing the HPE NS204i-u Boot Device V2 cage from the power supply bay](#)

[Removing and replacing a boot device drive](#)

Removing and replacing the HPE NS204i-u Boot Device V2 from Box 3

Prerequisites

Before beginning installation, make sure that the server is updated with the latest operating system firmware and drivers.

Before you perform this procedure, make sure that you have a T-10 Torx screwdriver available.

About this task



CAUTION

A discharge of static electricity from a finger or other conductor might damage system boards or other static-sensitive devices. To prevent damage, observe [antistatic precautions](#).

Procedure

1. [Back up all server data.](#)
2. [Power down the server.](#)
3. Remove all power:
 - a. Disconnect each power cord from the power source.
 - b. Disconnect each power cord from the server.
4. Disconnect all peripheral cables from the server.
5. [Remove the server from the rack.](#)
6. Place the server on a flat, level work surface.
7. If installed, [remove the front bezel.](#)
8. [Remove the access panel.](#)
9. [Remove the middle cover.](#)
10. [Disconnect the power and signal cables from the system board.](#)
11. Remove the multipurpose cage from the server.

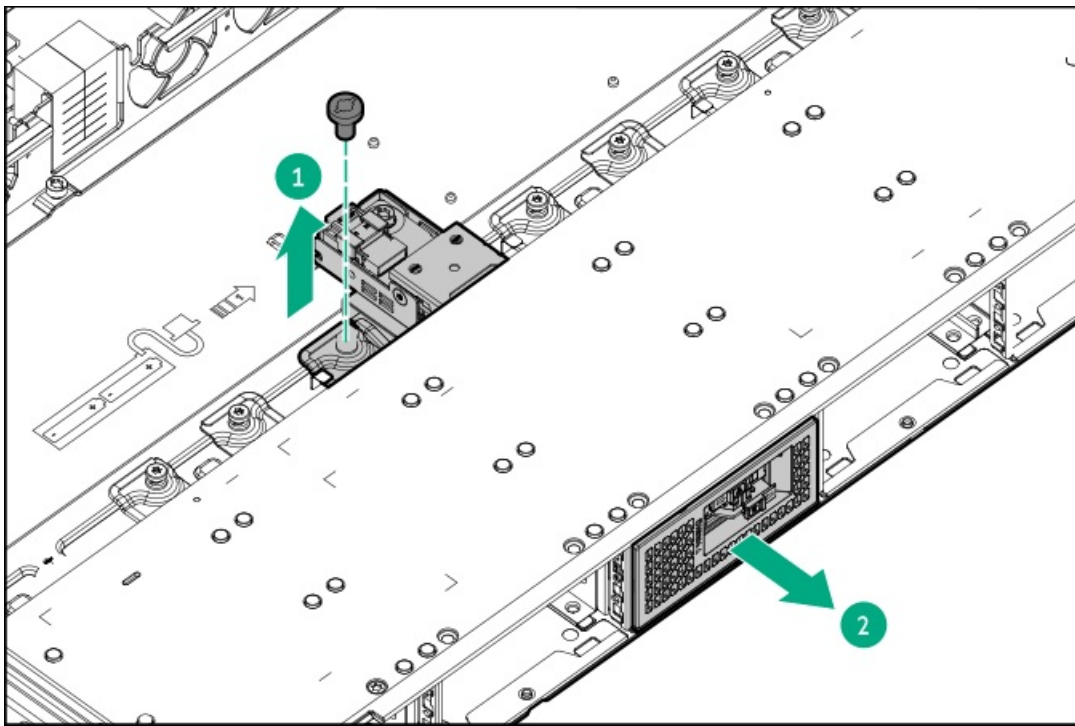

12. Remove the boot device bracket from the multipurpose cage.

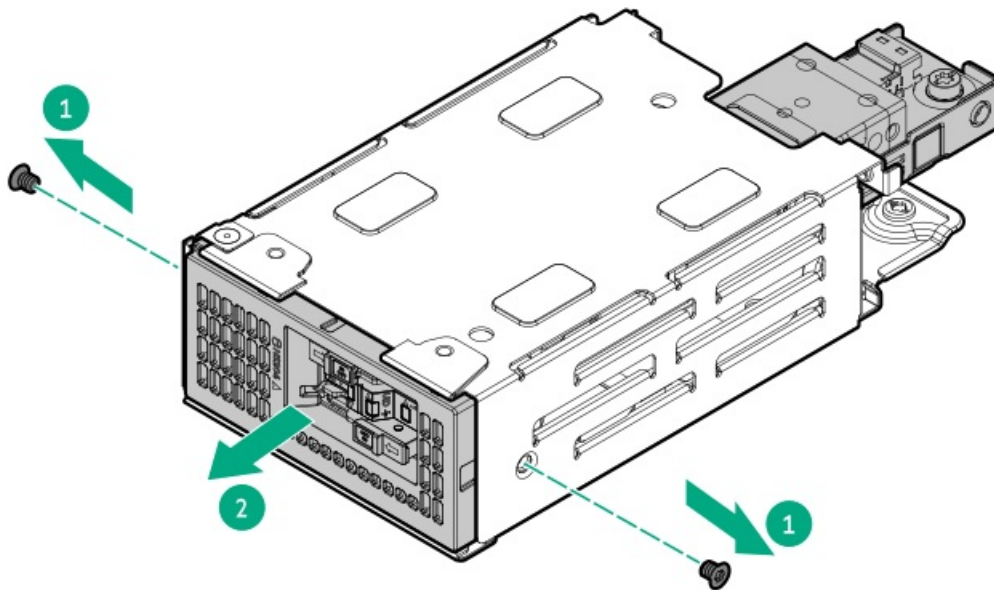

13. Remove the boot device cage from the bracket.



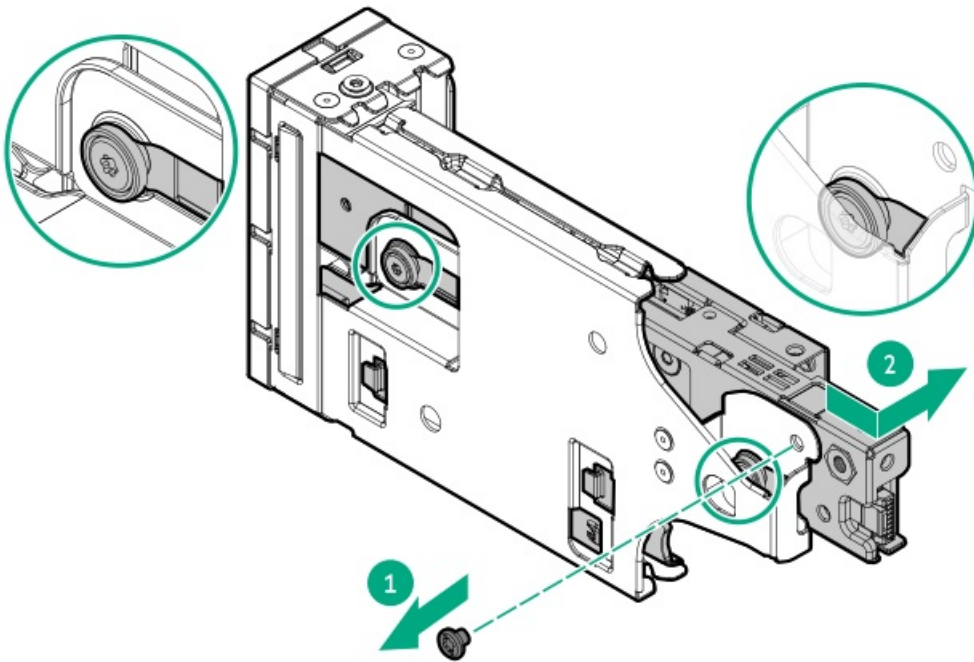

14. Disconnect the cables from the boot device.

15. Remove the boot device carrier:

- a. Press and hold the carrier latch.
- b. Pivot the latch to open.
- c. Slide the carrier out from the boot device cage.

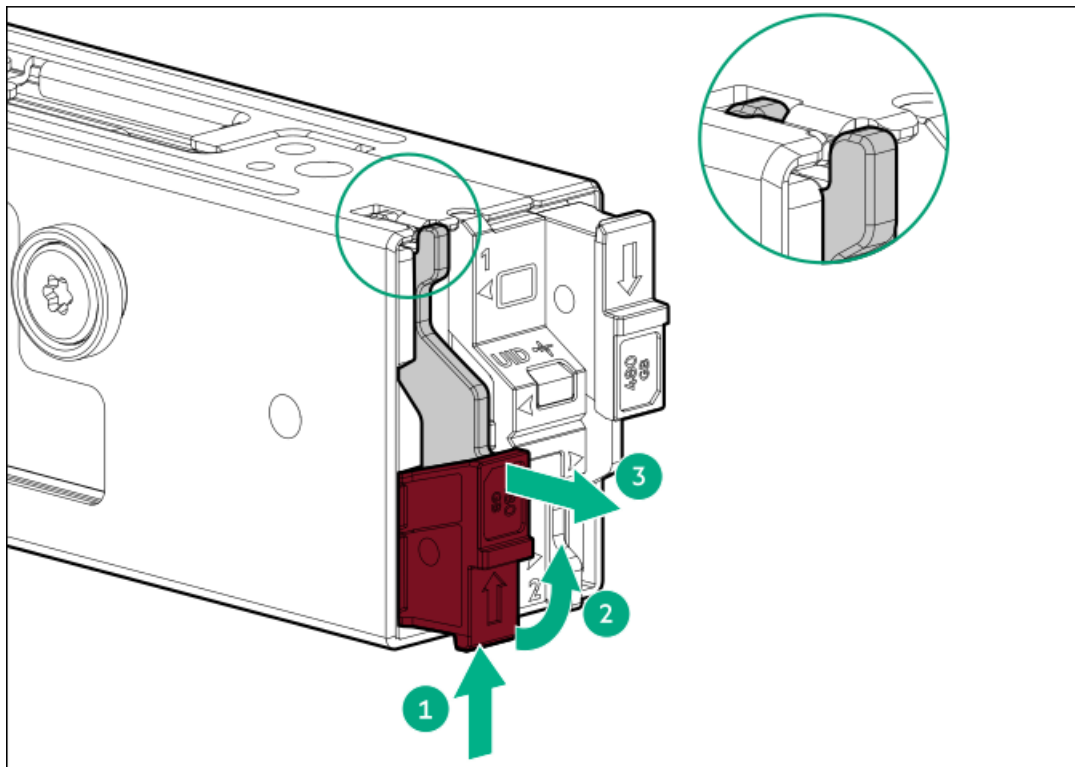

16. If installed, remove the SSD from the boot device carrier:

- a. Remove the SSD mounting screw.
- b. Tilt the SSD at a 45° angle, and then carefully remove the SSD from the M.2 slot.

Retain the SSD and mounting screw for installation onto the new boot device carrier.

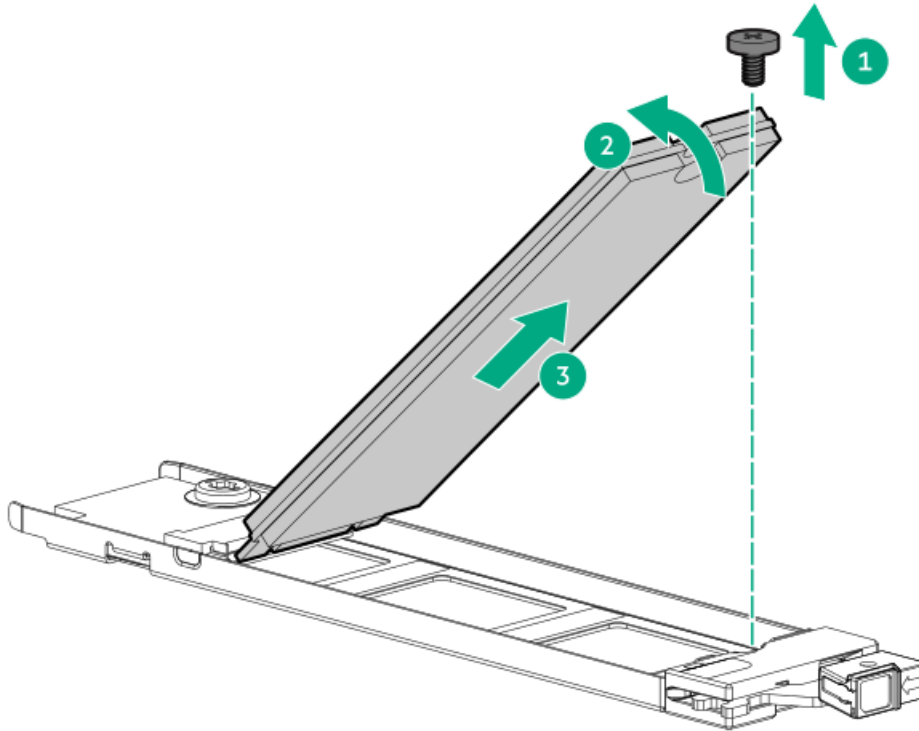

Results

The removal procedure is complete. To replace the component, reverse this procedure.

Removing and replacing the HPE NS204i-u Boot Device V2 from the chassis

Prerequisites

Before beginning installation, make sure that the server is updated with the latest operating system firmware and drivers.

Before you perform this procedure, make sure that you have a T-10 Torx screwdriver available.

About this task



CAUTION

A discharge of static electricity from a finger or other conductor might damage system boards or other static-sensitive devices. To prevent damage, observe [antistatic precautions](#).

Procedure

1. [Power down the server](#).
2. Remove all power:
 - a. Disconnect each power cord from the power source.
 - b. Disconnect each power cord from the server.
3. Disconnect all peripheral cables from the server.
4. [Remove the server from the rack](#).
5. Place the server on a flat, level work surface.

6. Remove the access panel.
7. Remove the middle cover.
8. Disconnect the power and signal cables from the system board.
9. Remove the boot device:
 - 4 LFF drive configuration

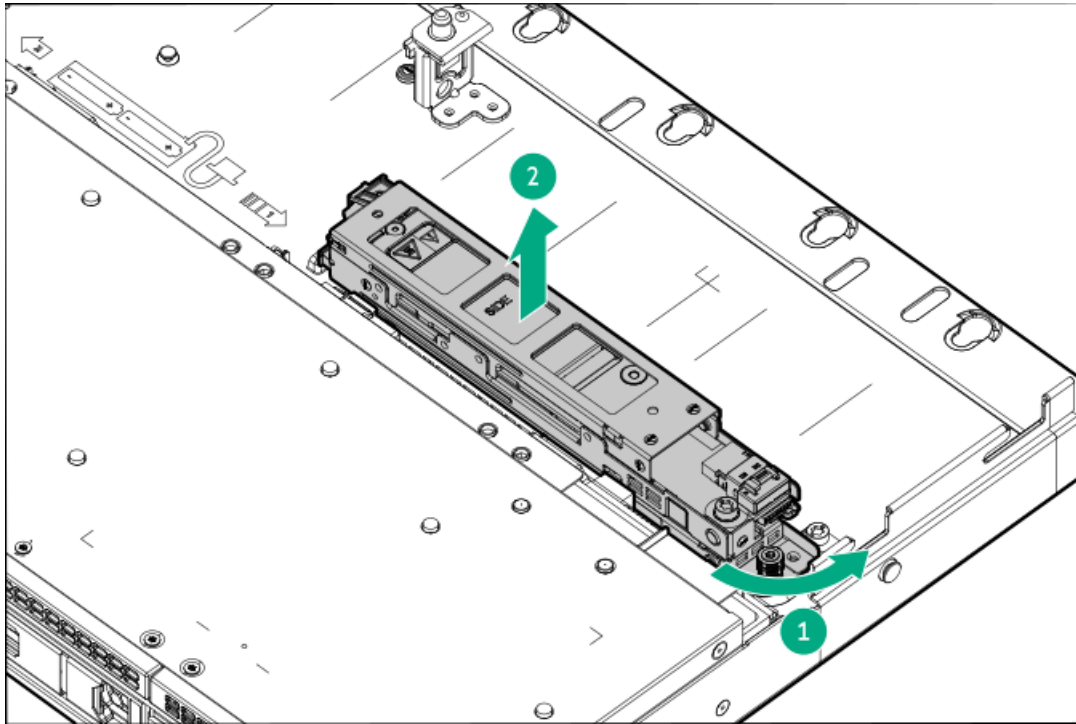

- GPU configuration

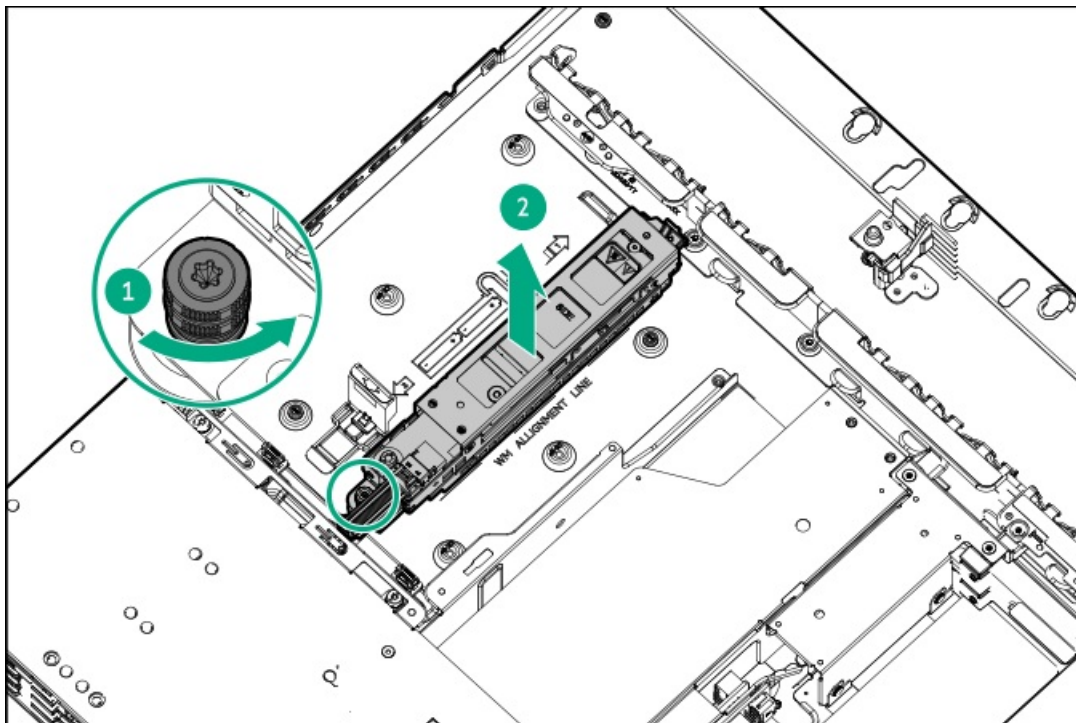

10. Remove the support bracket

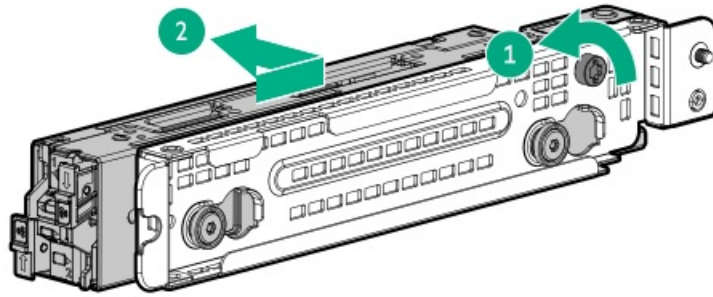

11. Disconnect the cables from the boot device.
12. Remove the boot device carrier:
 - a. Press and hold the carrier latch.
 - b. Pivot the latch to open.
 - c. Slide the carrier out from the boot device cage.

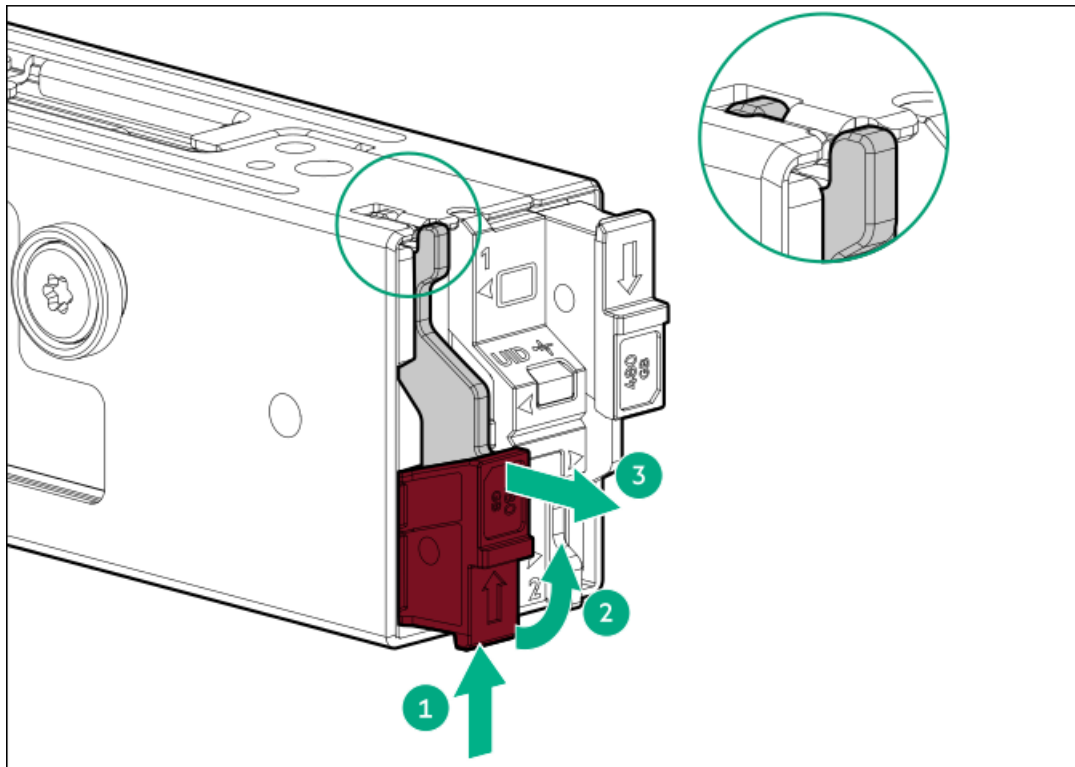

13. If installed, remove the SSD from the boot device carrier:
 - a. Remove the SSD mounting screw.
 - b. Tilt the SSD at a 45° angle, and then carefully remove the SSD from the M.2 slot.

Retain the SSD and mounting screw for installation onto the new boot device carrier.



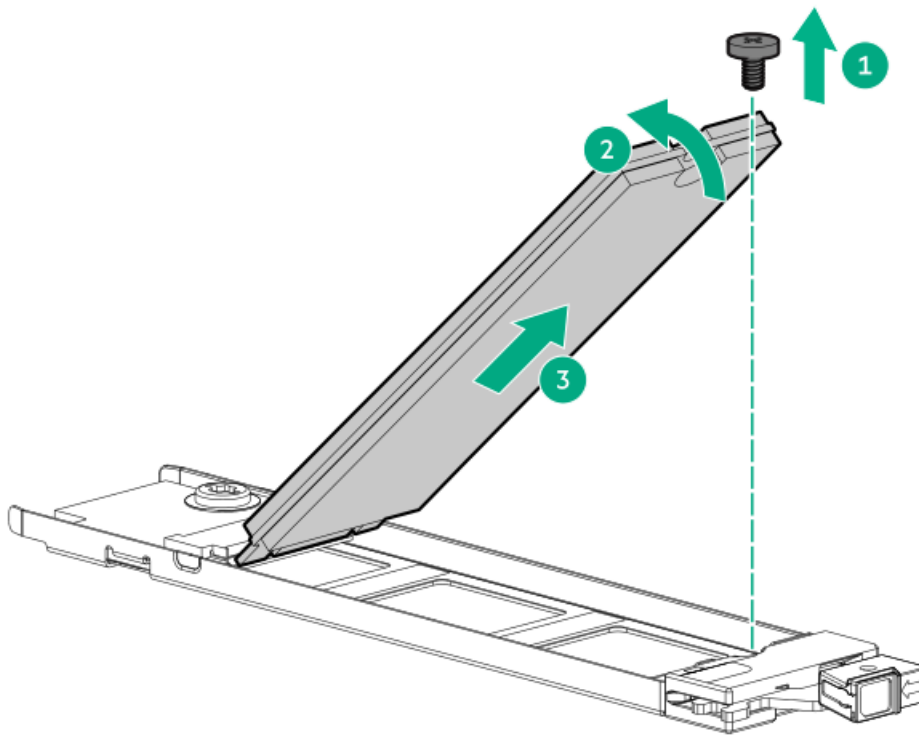

Results

To replace the component, reverse the removal procedure.

Removing and replacing HPE NS204i-u Boot Device V2 from the rear of the chassis

Prerequisites

Before beginning installation, make sure that the server is updated with the latest operating system firmware and drivers.

Before you perform this procedure, make sure that you have a T-10 Torx screwdriver available.

About this task



CAUTION

A discharge of static electricity from a finger or other conductor might damage system boards or other static-sensitive devices. To prevent damage, observe [antistatic precautions](#).

Procedure

1. [Power down the server](#).
2. Remove all power:
 - a. Disconnect each power cord from the power source.
 - b. Disconnect each power cord from the server.
3. Disconnect all peripheral cables from the server.
4. [Remove the server from the rack](#).
5. Place the server on a flat, level work surface.
6. [Remove the access panel](#).

7. Remove the middle cover.
8. Do the following:
 - Remove the riser cages.
 - Remove the low-profile riser cage blank.
9. Disconnect the power and signal cables from the system board.
10. Remove the boot device cage assembly:

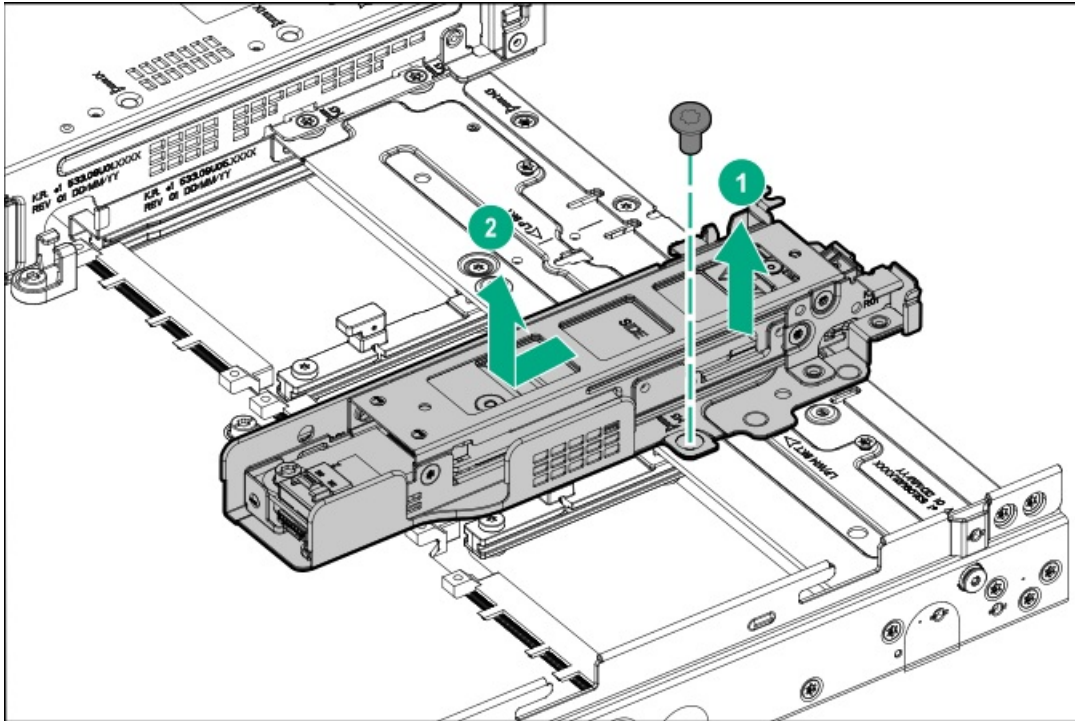

11. Remove the boot device from the bracket.

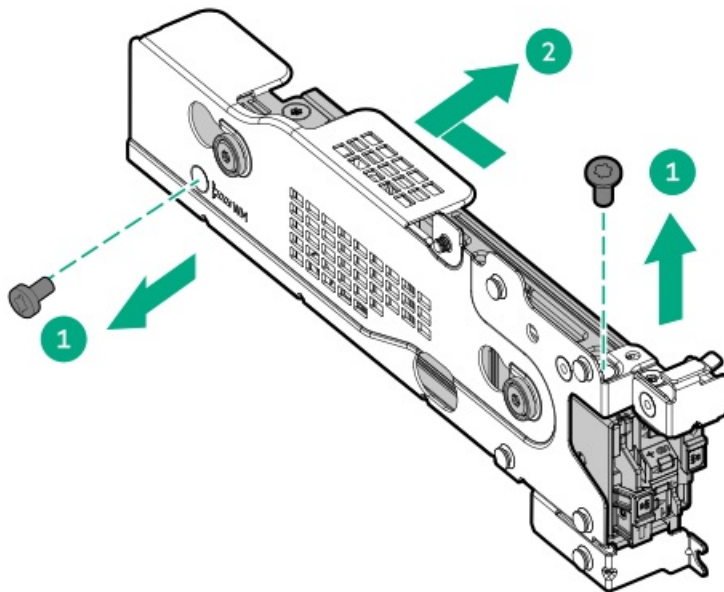

12. Disconnect the cables from the boot device.
13. Remove the boot device carrier:

- a. Press and hold the carrier latch.
- b. Pivot the latch to open.
- c. Slide the carrier out from the boot device cage.

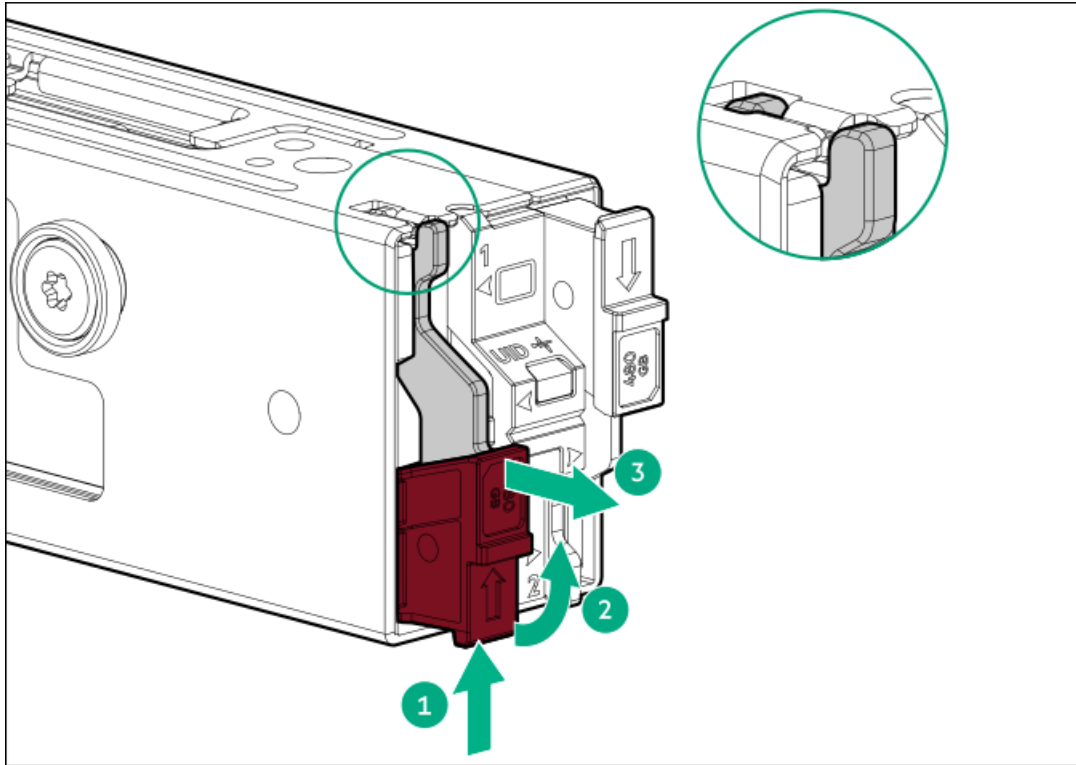

14. If installed, remove the SSD from the boot device carrier:

- a. Remove the SSD mounting screw.
- b. Tilt the SSD at a 45° angle, and then carefully remove the SSD from the M.2 slot.

Retain the SSD and mounting screw for installation onto the new boot device carrier.

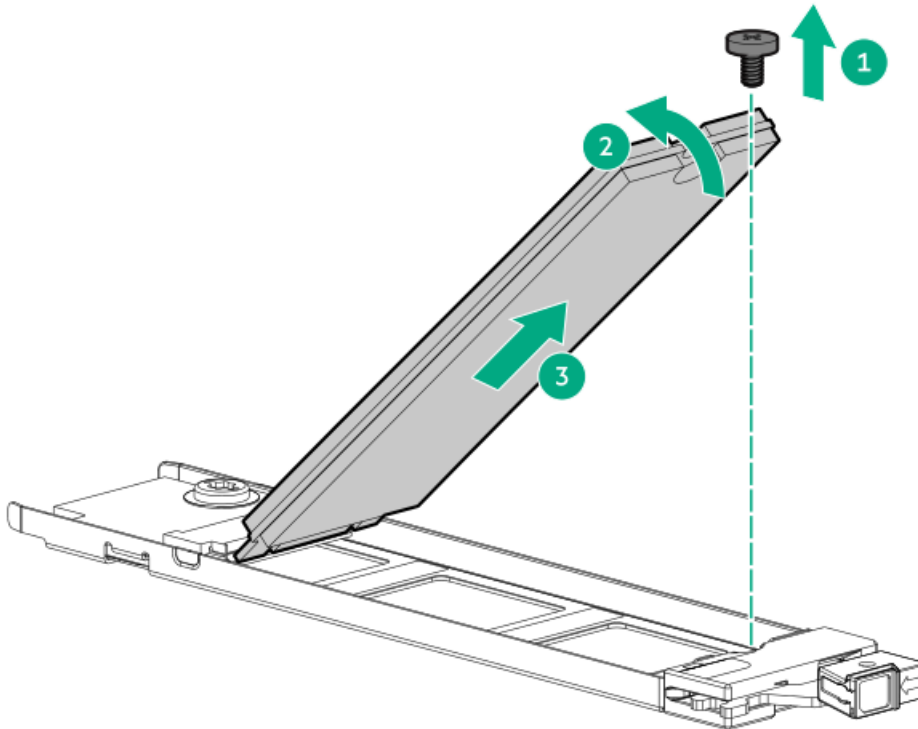

Results

To replace the component, reverse the removal procedure.

Removing and replacing the HPE NS204i-u Boot Device V2 cage from the power supply bay

About this task

https://sketchfab.com/models/4489848dcce04ac9848f04ca23f6cd1a/embed?ui_infos=0&ui_watermark=0&ui_help=0&ui_vr=0&ui_settings=0&ui_inspector=0&ui_hint=2&ui_color=01a982&ui_theme=dark&autostart=1&camera=0&



CAUTION

A discharge of static electricity from a finger or other conductor might damage system boards or other static-sensitive devices. To prevent damage, observe [antistatic precautions](#).

Procedure

1. [Back up all server data.](#)
2. [Power down the server.](#)
3. If installed, [release the cable management arm.](#)
4. Remove all power:
 - a. Disconnect each power cord from the power source.
 - b. Disconnect each power cord from the server.
5. Disconnect all peripheral cables from the server.
6. [Remove the server from the rack.](#)
7. Place the server on a flat, level work surface.
8. [Remove the access panel.](#)
9. If installed, [remove the power supply from bay 2.](#)
10. [Disconnect the boot device signal and power cables from the system board.](#)
11. Remove the boot device cage:
 - a. Remove the screw.
 - b. Push the cage from the back to detach it from the power supply bay.
 - c. Remove the boot device cage.

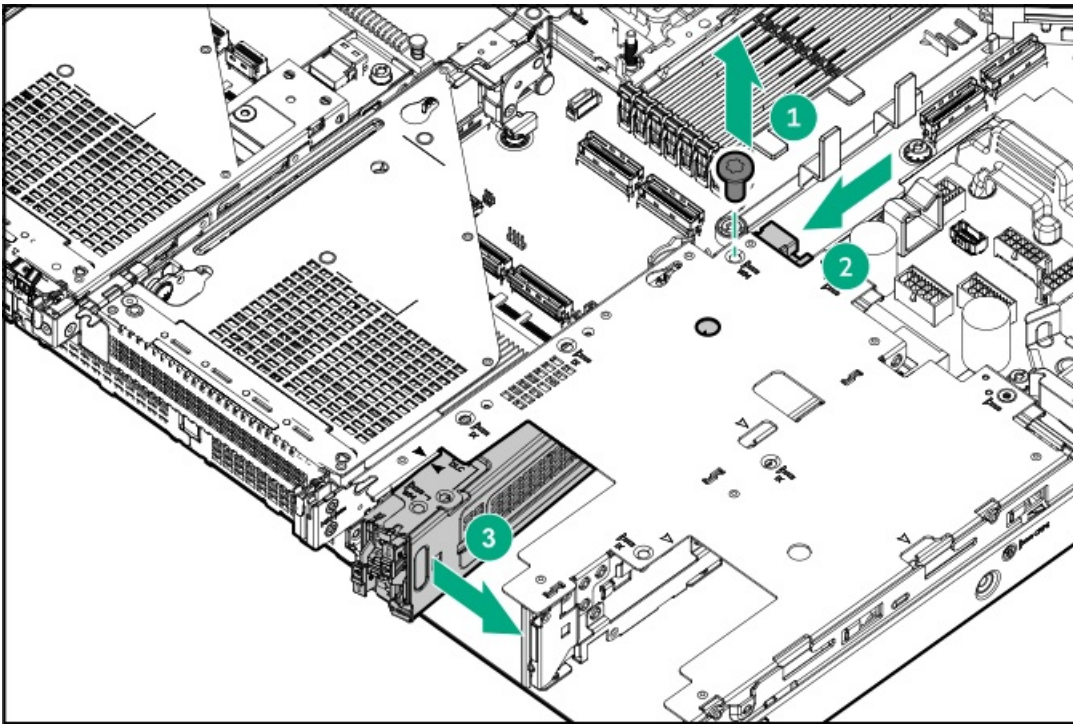

12. Remove the boot device cage assembly from the bracket.

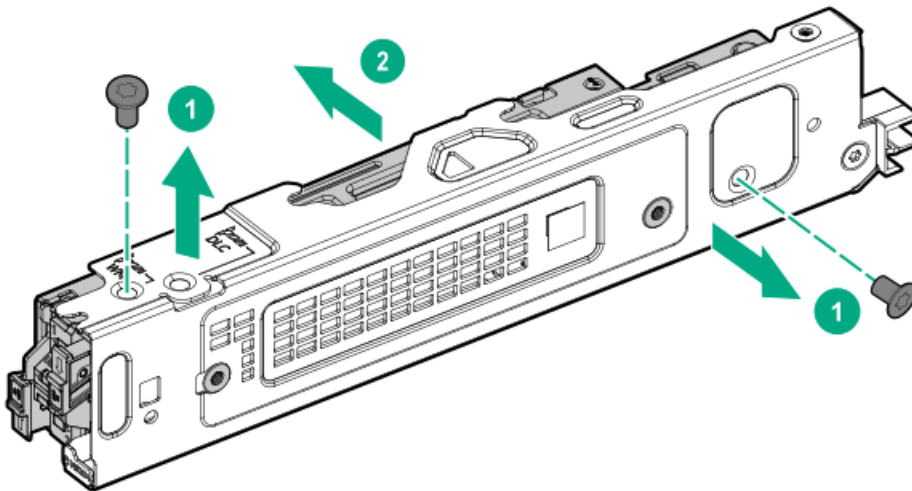

13. Disconnect the signal and power cables from the boot device.

14. Remove the boot device carrier:

- a. Press and hold the carrier latch.
- b. Pivot the latch to open.
- c. Slide the carrier out from the boot device cage.



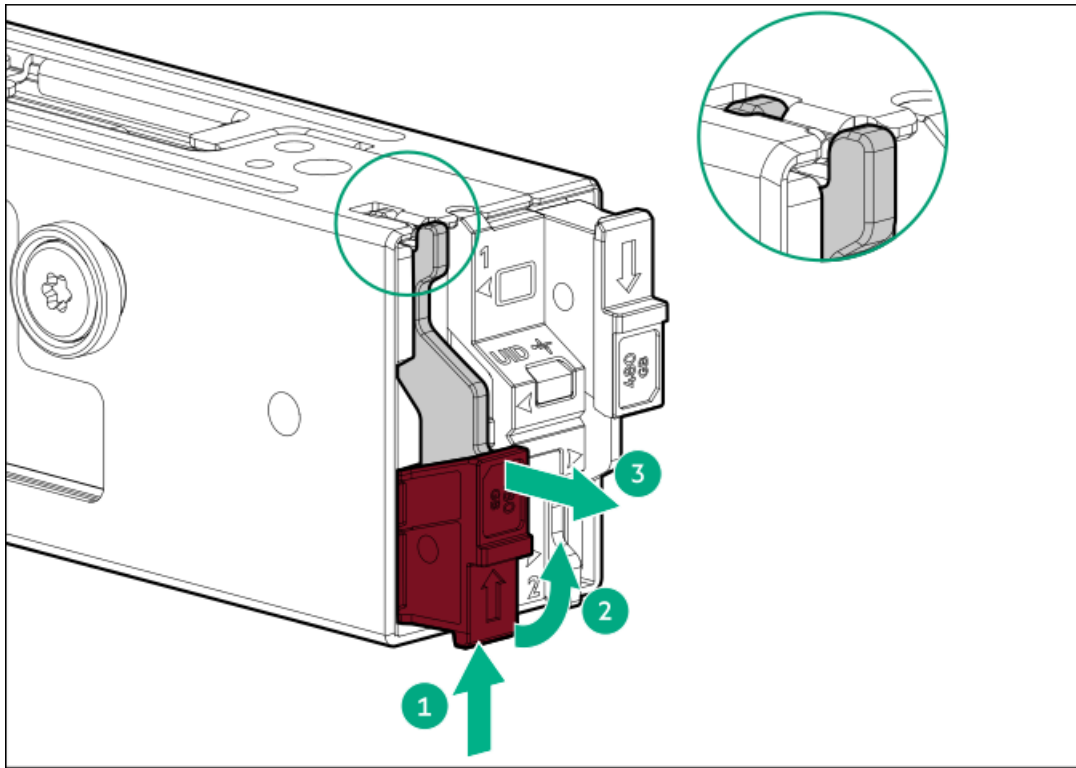

15. If installed, remove the SSD from the boot device carrier:

- a. Remove the SSD mounting screw.
- b. Tilt the SSD at a 45° angle, and then carefully remove the SSD from the M.2 slot.

Retain the SSD and mounting screw for installation onto the new boot device carrier.

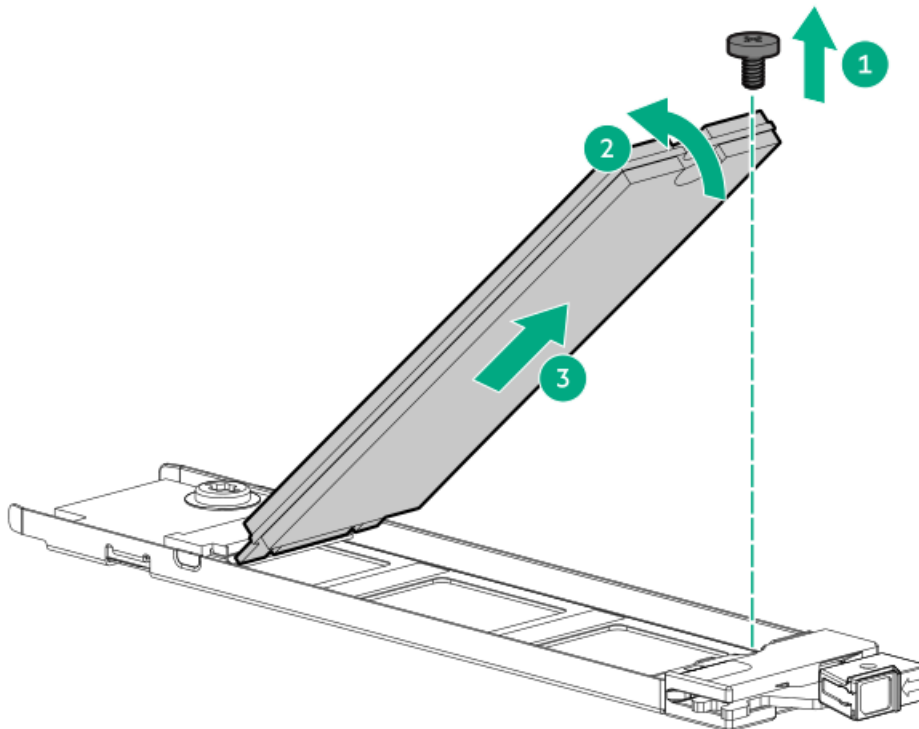

Results

To replace the component, reverse the removal procedure.

Removing and replacing a boot device drive

Prerequisites

Before you perform this procedure, make sure that you have a Phillips No. 1 screwdriver available.

About this task

https://sketchfab.com/models/bbb61184a86a4ca792b988e9caae5278/embed?ui_infos=0&ui_watermark=0&ui_help=0&ui_vr=0&ui_settings=0&ui_inspector=0&ui_hint=2&ui_color=01a982&ui_theme=dark&autostart=1&camera=0&ui_animations=0



CAUTION

Before replacing a DIMM, backplane, expansion card, riser board, or other similar PCA components due to a perceived hardware error, make sure first that the component is firmly seated in the slot.

When installing the replacement component:

- Observe antistatic precautions.
- Handle the PCA only along the edges.
- Do not touch the components and connectors on the PCA.
- Do not bend or flex the PCA.



IMPORTANT

For successful RAID 1 configuration, verify that the boot device SSDs have the same model number and firmware version:

- In the iLO web interface, see the Storage page.
- In UEFI System Utilities, see System Configuration > HPE NS204i Boot Controller > Physical Device Information.

Configurations with SSDs from different manufacturers are not supported.

Procedure

1. Back up all server data.
2. Observe the drive LED status and determine if the drive can be removed.
3. Remove the failed drive and replace it with a new drive:
 - a. Press and hold the carrier latch.
 - b. Pivot the latch to open.
 - c. Slide the carrier out from the boot device cage.

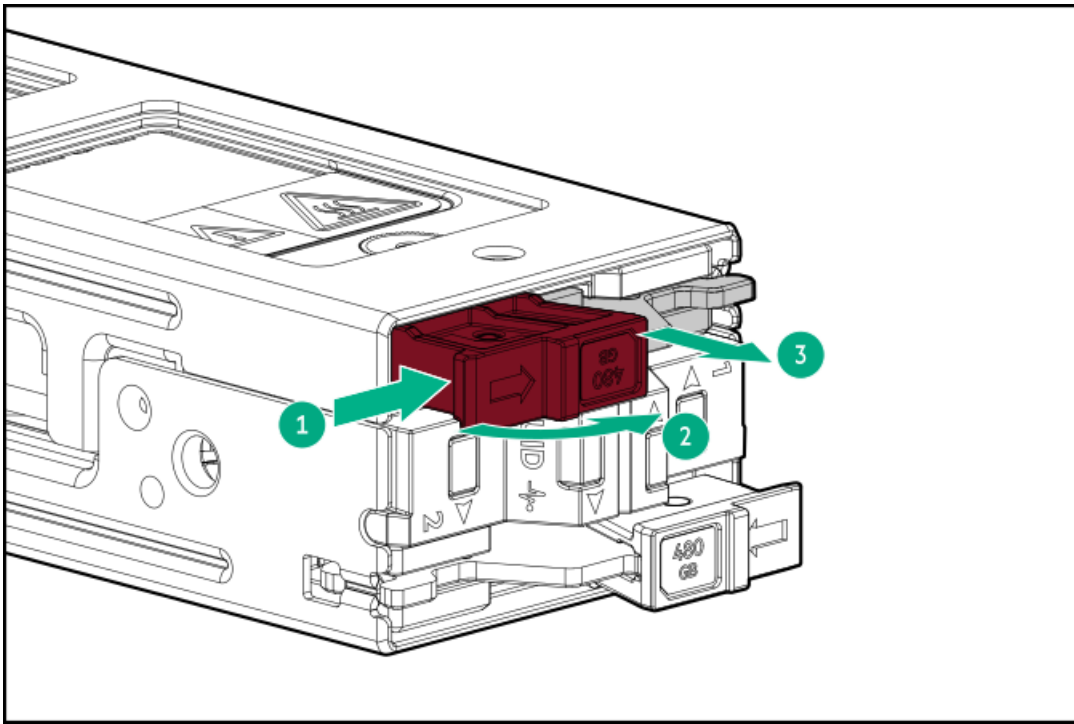

- d. Remove the SSD mounting screw.
- e. Tilt the SSD at a 45° angle, and then remove the failed SSD from the M.2 slot.

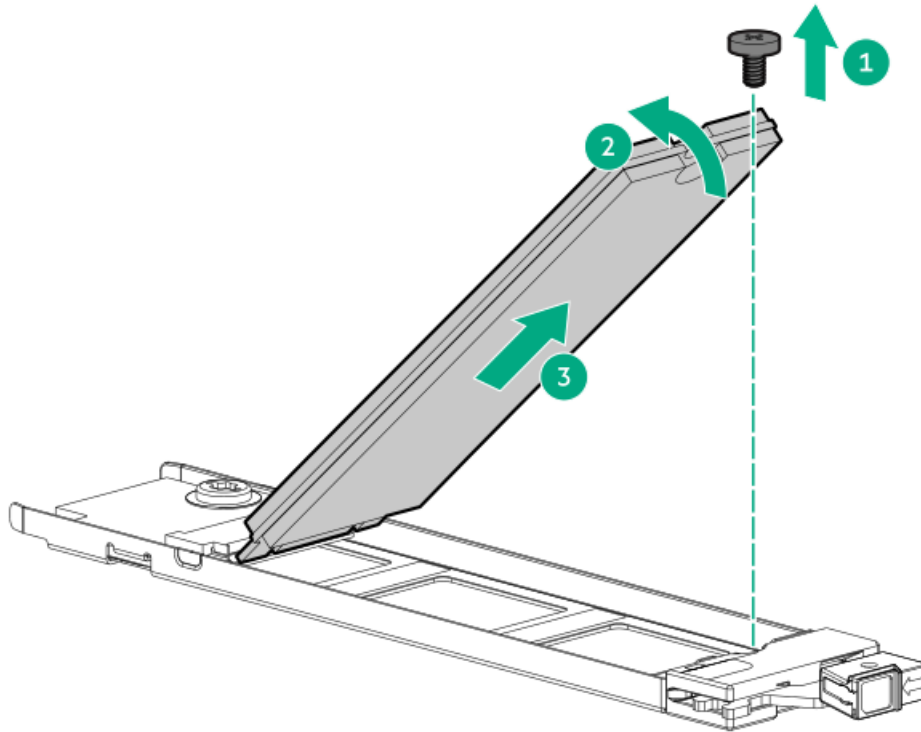

- f. Insert the new SSD into the M.2 slot at a 45° angle.
- g. Carefully press the SSD down to the horizontal position.
- h. Install the SSD mounting screw.

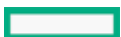

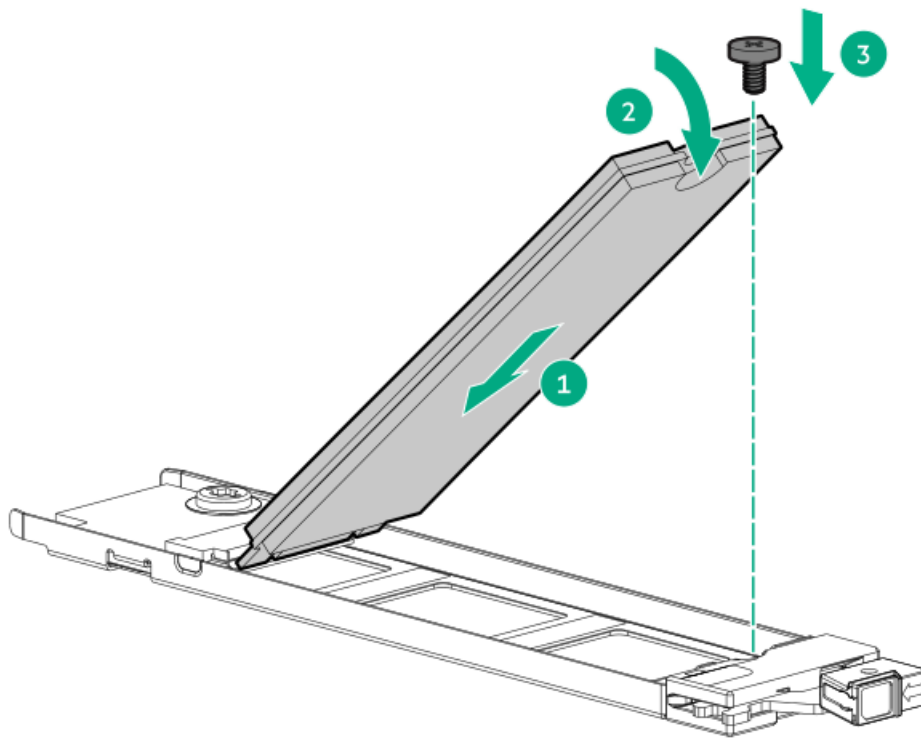

- i. If closed, pivot the carrier latch to open.
- j. Slide the carrier with the new SSD into the boot device cage.
- k. Pivot the latch to close.

Make sure that the carrier latch is locked on the boot device cage.

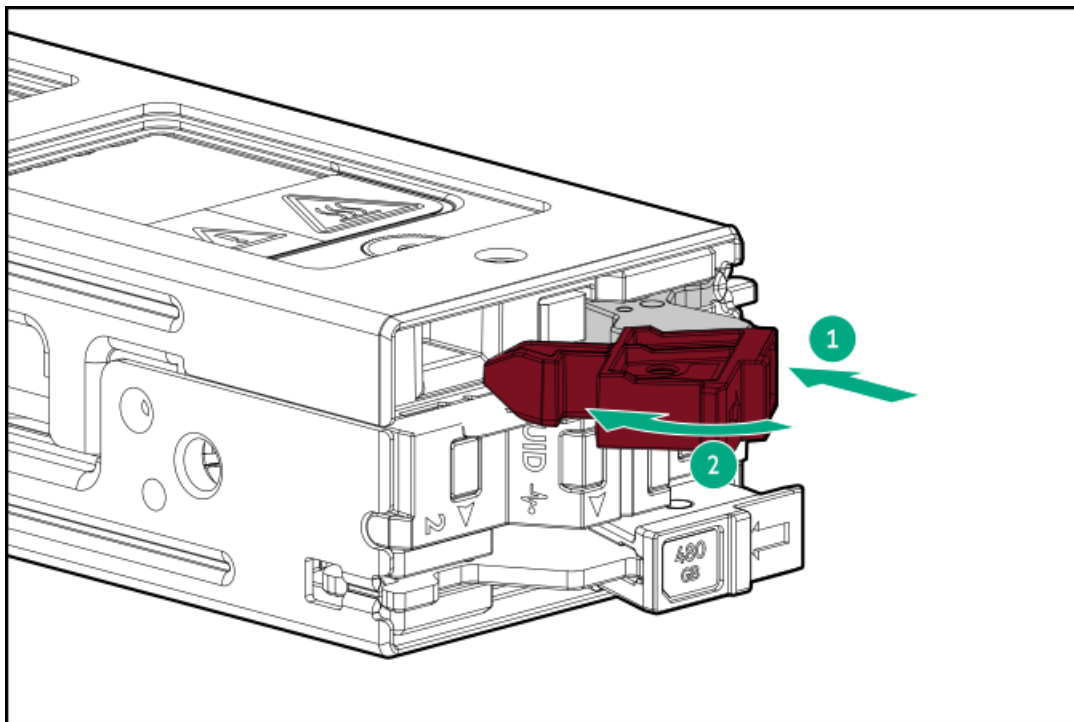

The boot device automatically rebuilds the RAID 1 volume.

- 4. Remove the failed SSD from the boot device carrier:
 - a. Remove the SSD mounting screw.
 - b. Tilt the SSD at a 45° angle, and then carefully remove the SSD from the M.2 slot.



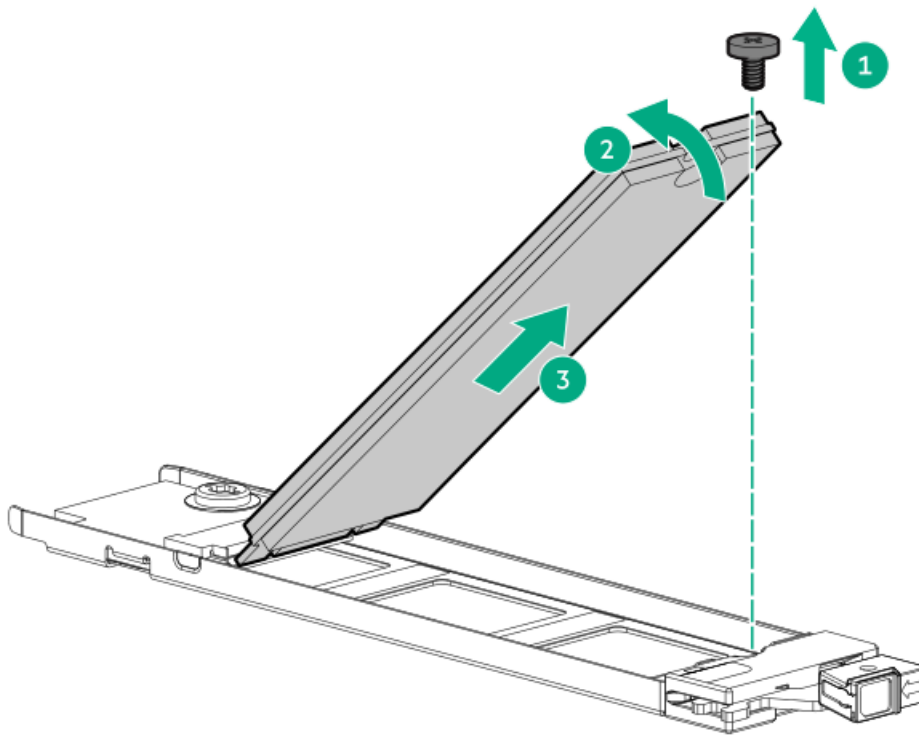

Results

The removal procedure is complete. To replace the component, reverse this procedure.

Heatsink replacement

Subtopics

[Removing a heatsink](#)

[Removing a closed-loop liquid cooling heatsink](#)

[Installing the heatsink](#)

[Installing a closed-loop liquid cooling heatsink](#)

Removing a heatsink

Prerequisites

- [Identify the heatsink and processor socket components.](#)
- [Review the processor cautions.](#)
- Before you perform this procedure, make sure that you have the following items available:
 - T-30 Torx screwdriver
 - Alcohol wipe

About this task

https://sketchfab.com/models/9fe740559dd94ff49c7da212d810cf68/embed?ui_infos=0&ui_watermark=0&ui_help=0&ui_vr=0&ui_settings=0&ui_inspector=0&ui_hint=2&ui_color=01a982&ui_theme=dark&autostart=1&camera=0&



WARNING

To reduce the risk of personal injury from hot surfaces, allow the drives and the internal system components to cool before touching them.



CAUTION

A discharge of static electricity from a finger or other conductor might damage system boards or other static-sensitive devices. To prevent damage, observe antistatic precautions.

Procedure

1. Power down the server.
2. Remove all power:
 - a. Disconnect each power cord from the power source.
 - b. Disconnect each power cord from the server.
3. Disconnect all peripheral cables from the server.
4. Remove the server from the rack
5. Remove the access panel.
6. Remove the middle cover.
7. Allow all internal system components to cool before continuing.
8. Remove a standard or high performance heatsink:



CAUTION

To prevent mechanical damage or depositing oil on your hands or other contaminants to the heatsink contact surface, hold the heatsink only by the edge of its base plate. Do not touch the heatsink fins.

- a. Review the heatsink screw numbering on the heatsink label.
- b. Loosen one pair of diagonally opposite screws, and then loosen the other pair of screws.
 - Standard heatsink

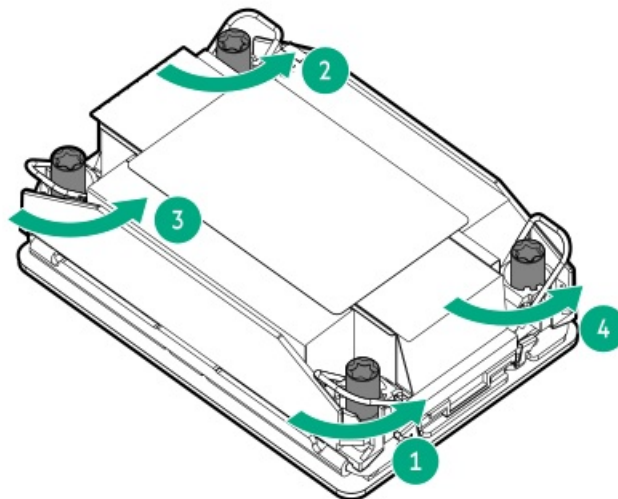

- Performance heatsink

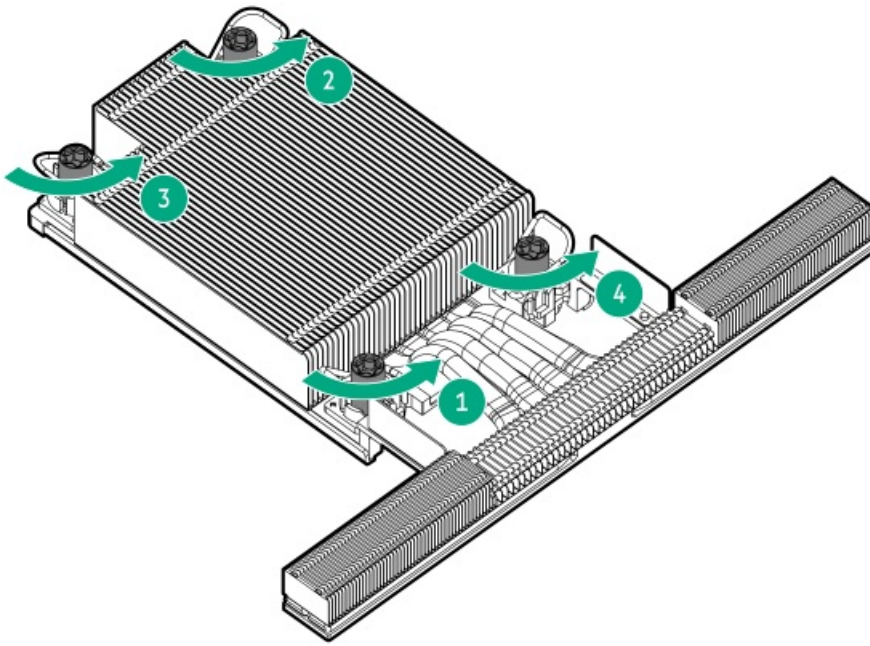

9. Set the anti-tilt wires to the unlocked position.

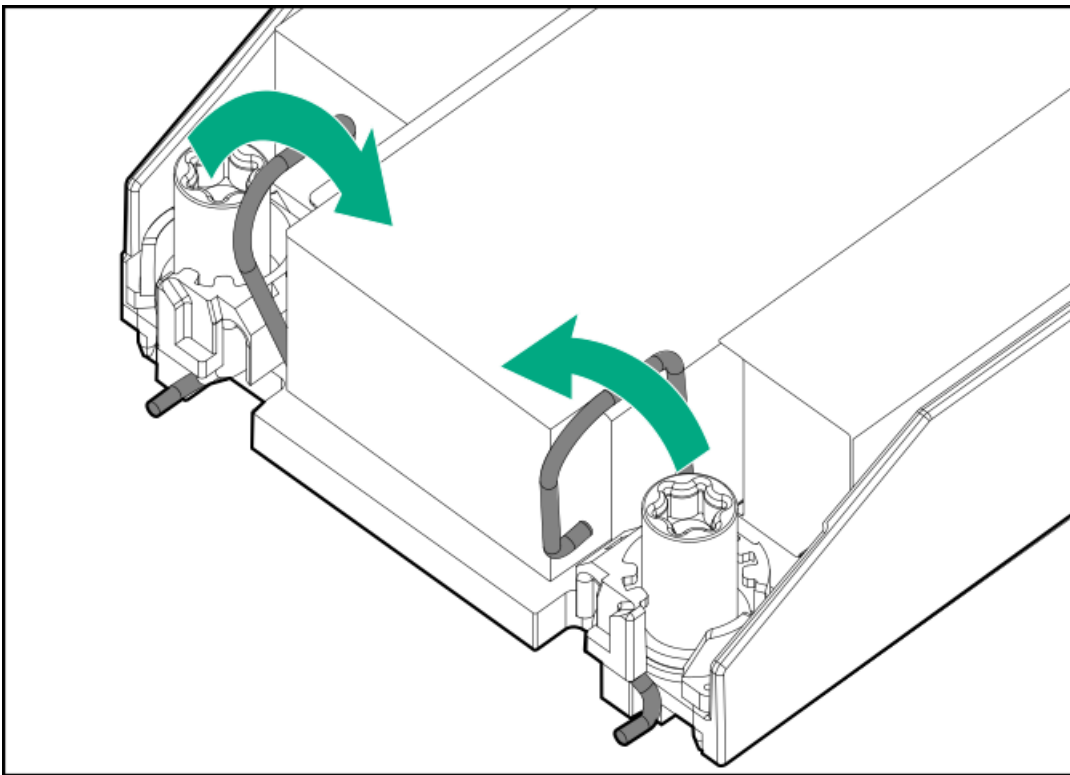

10. Lift the heatsink away from the processor socket.

- Standard heatsink



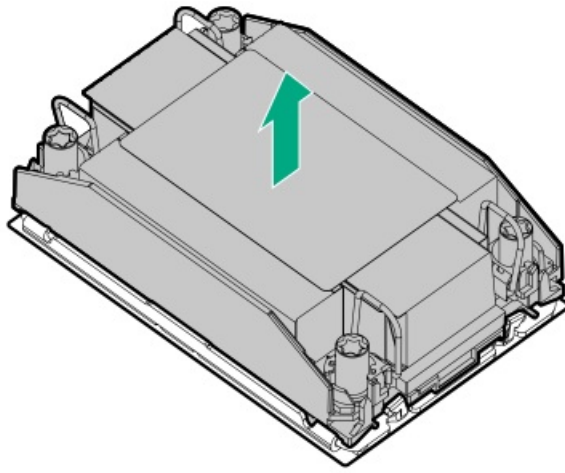

- Performance heatsink

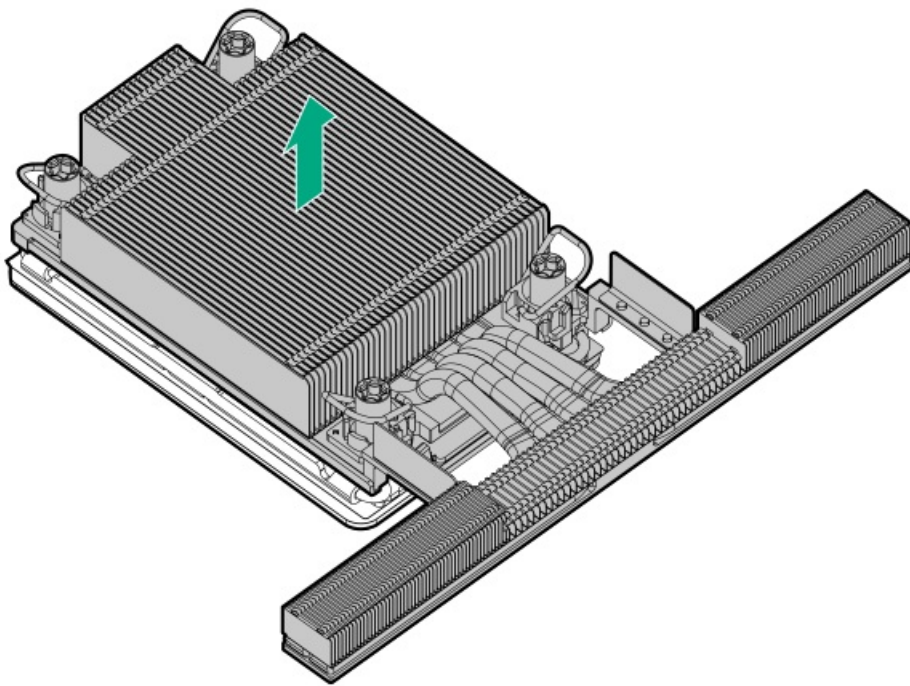

11. Set the anti-tilt wires to the locked position.

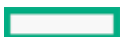

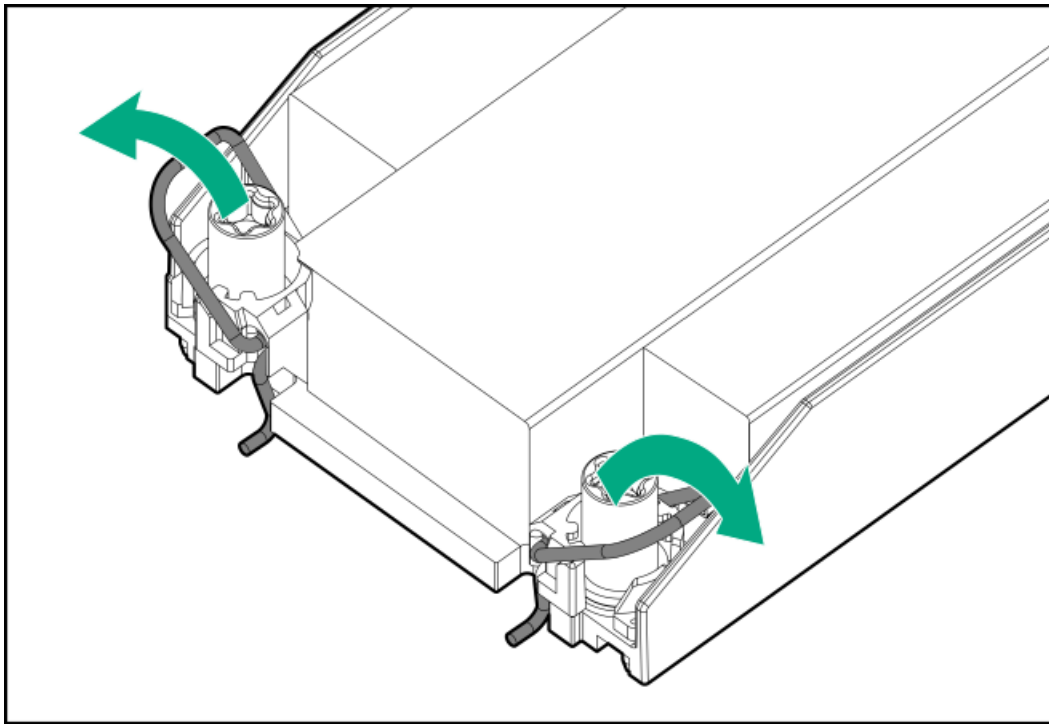

12. Place the heatsink on a flat work surface with its contact side facing up.
13. If you are not immediately installing the replacement processor-heat sink module, install the dust cover on the empty processor socket:



CAUTION

Do not press down on the dust cover. Pressing down on the dust cover might damage the processor socket.

- a. Press and hold the grip tabs on the dust cover.
- b. Carefully lower the dust cover onto the bolster plate guide posts.

Make sure that the corner holes of the dust cover are properly engaged with the guide posts on the bolster plate.

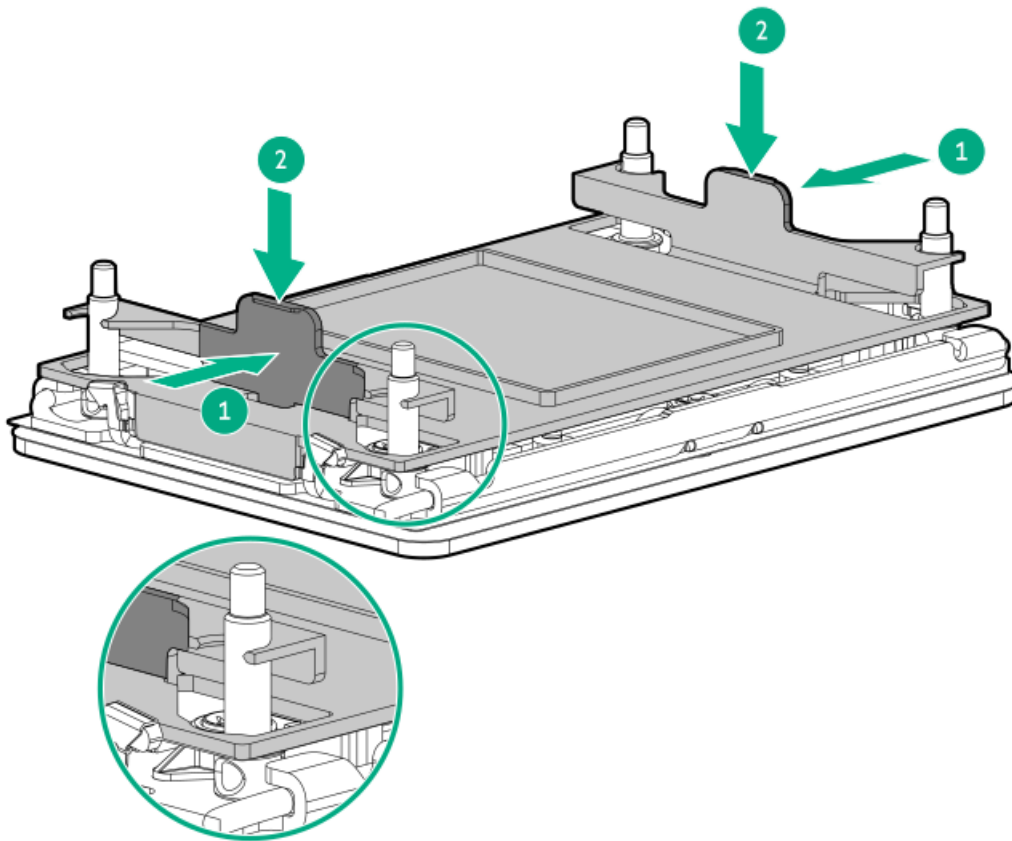

14. Remove the processor from the heatsink:

- a. Open the TIM breaker lever.

This action breaks the adhesion between the processor and the heatsink.

- b. Hold the processor on its edges, and then remove it from the carrier.

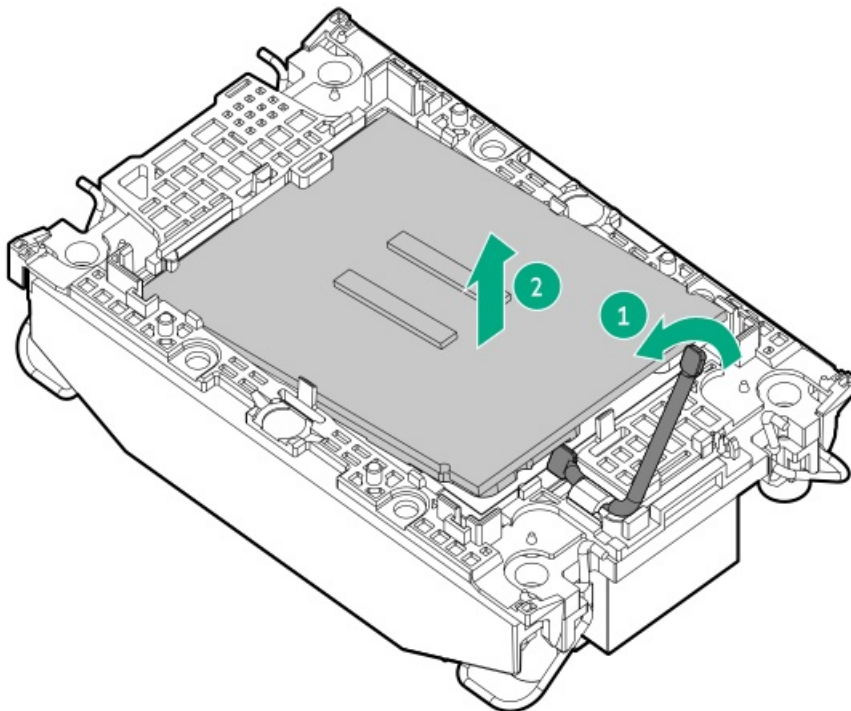

- c. Starting from the pin 1 corner and moving in an opposite manner, disengage the processor carrier release tabs from the heatsink.



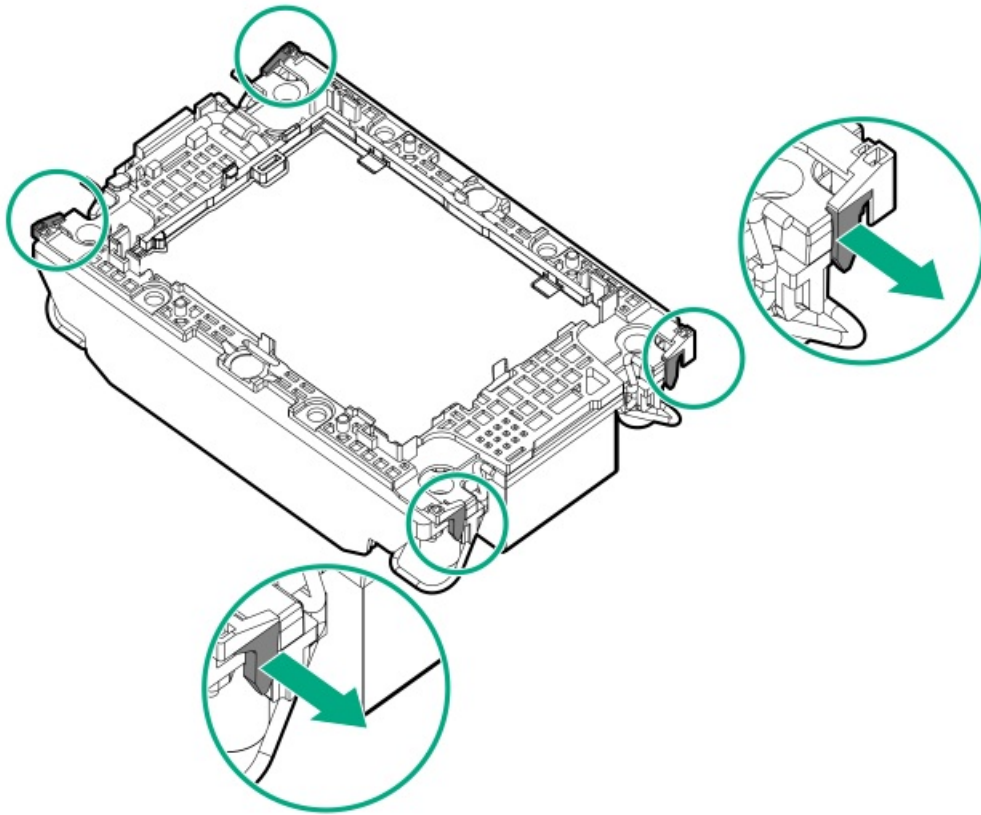

d. Lift the processor carrier away from the heatsink.



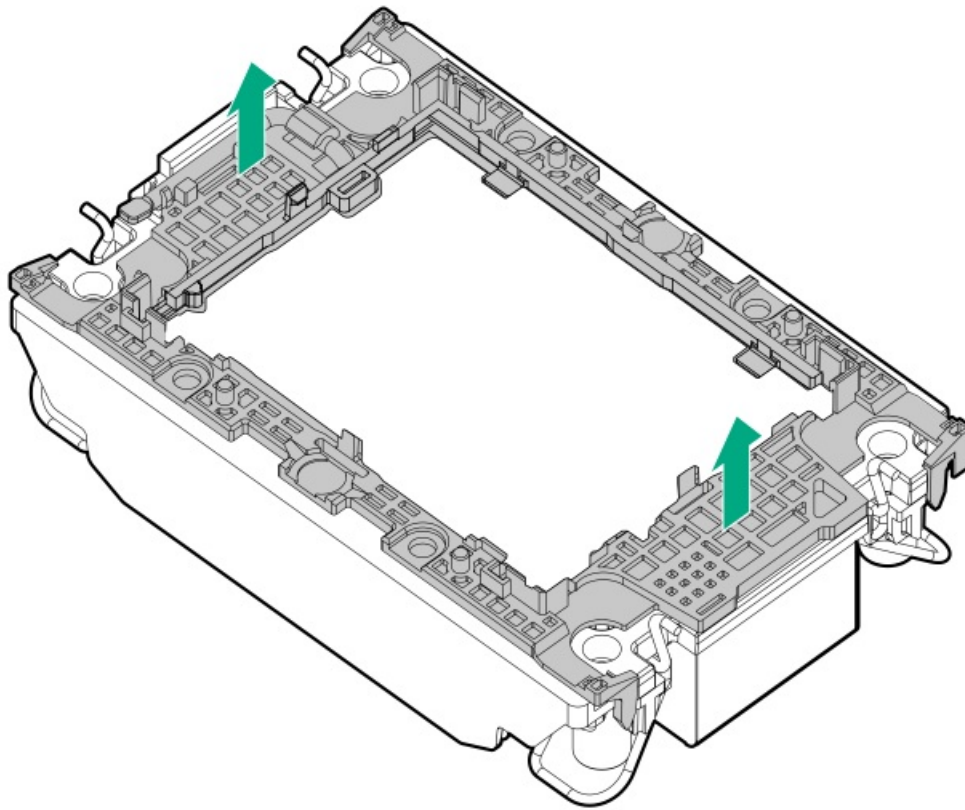

15. Use an alcohol wipe to remove the existing thermal grease from the heatsink and processor.

Allow the alcohol to evaporate before continuing.

Removing a closed-loop liquid cooling heatsink

About this task



IMPORTANT

This part is not customer serviceable. Parts identified as "No" in the [Illustrated Parts Catalog](#) are not designed for customer self-repair. To satisfy the customer warranty, Hewlett Packard Enterprise requires that an authorized service provider replace the part. If you suspect a failure, leave the part installed and contact a Hewlett Packard Enterprise authorized service provider.

Installing the heatsink

Prerequisites

Before you perform this procedure, make sure that you have a T-30 Torx screwdriver available.

About this task



CAUTION

A discharge of static electricity from a finger or other conductor might damage system boards or other static-sensitive devices. To prevent damage, observe [antistatic precautions](#).

Procedure

1. Do not touch the pins on the processor socket and the processor.



CAUTION

THE PINS ON THE PROCESSOR SOCKET AND ON THE PROCESSOR ARE VERY FRAGILE AND EASILY DAMAGED. Any damage to them might require replacing the system board.

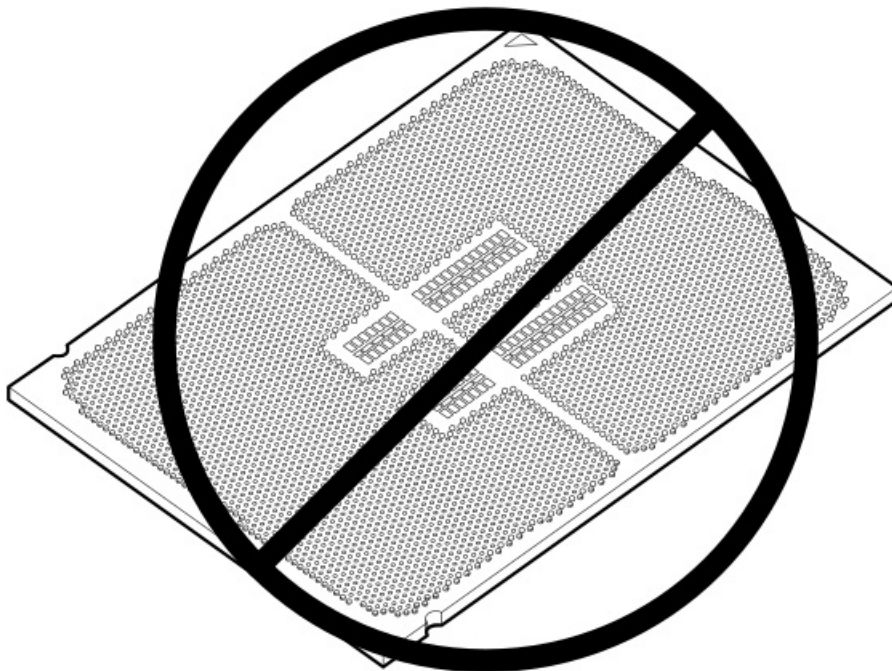
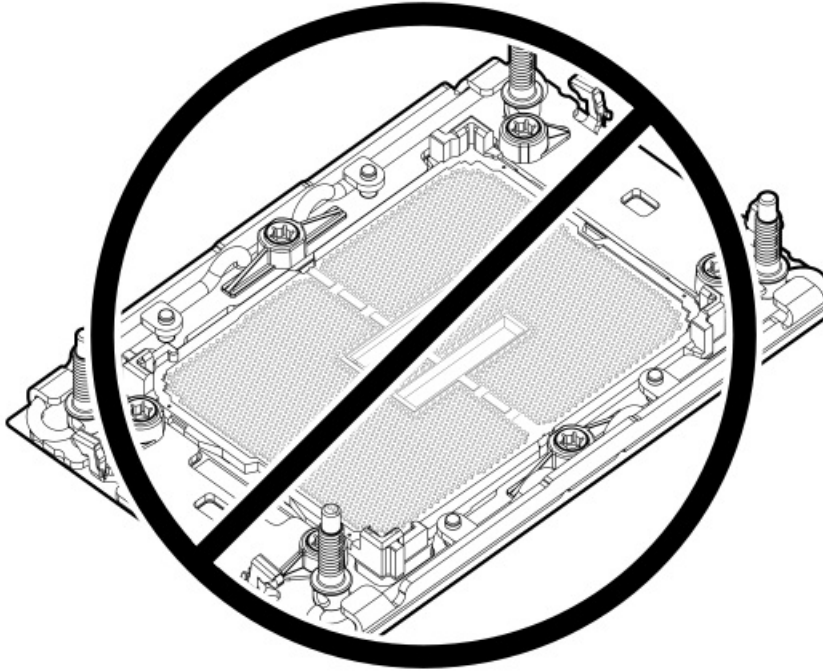

2. Install the processor carrier on the processor:
 - a. Align the pin 1 indicator on the processor carrier with that on the processor, and then press on the pair of opposite sides on the TIM breaker lever of the processor carrier until it clicks into place.

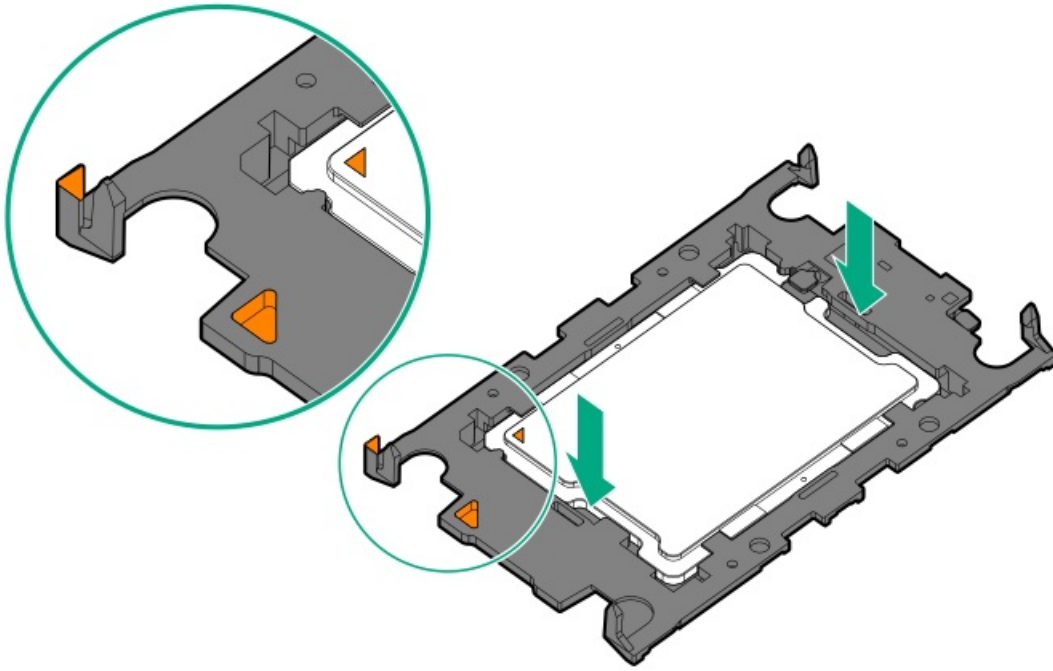

b. Verify that the processor is properly latched on the processor carrier.

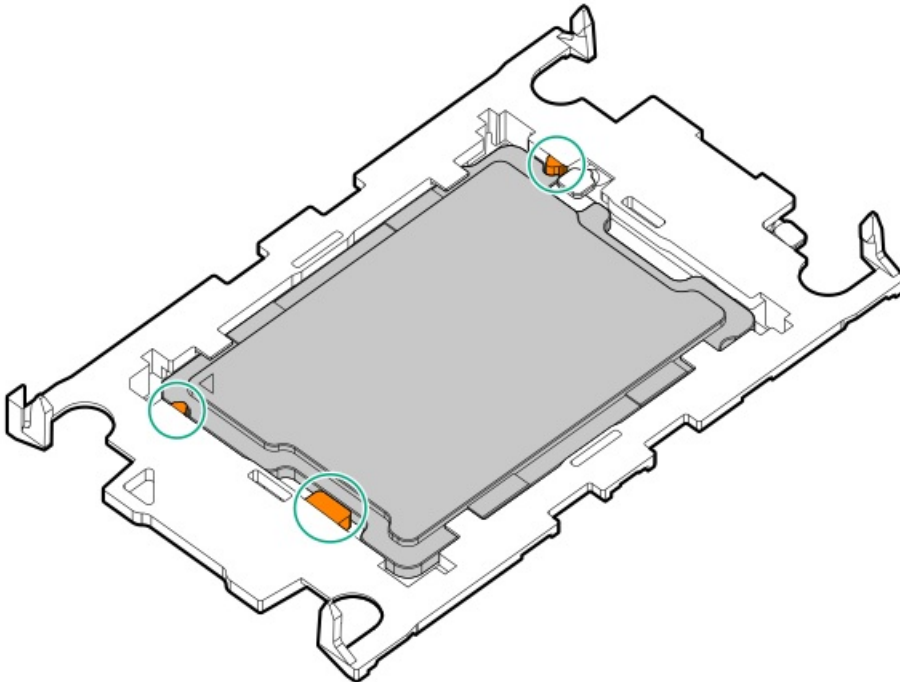

If not, press the other pair of opposite sides of the processor carrier until it clicks into place.



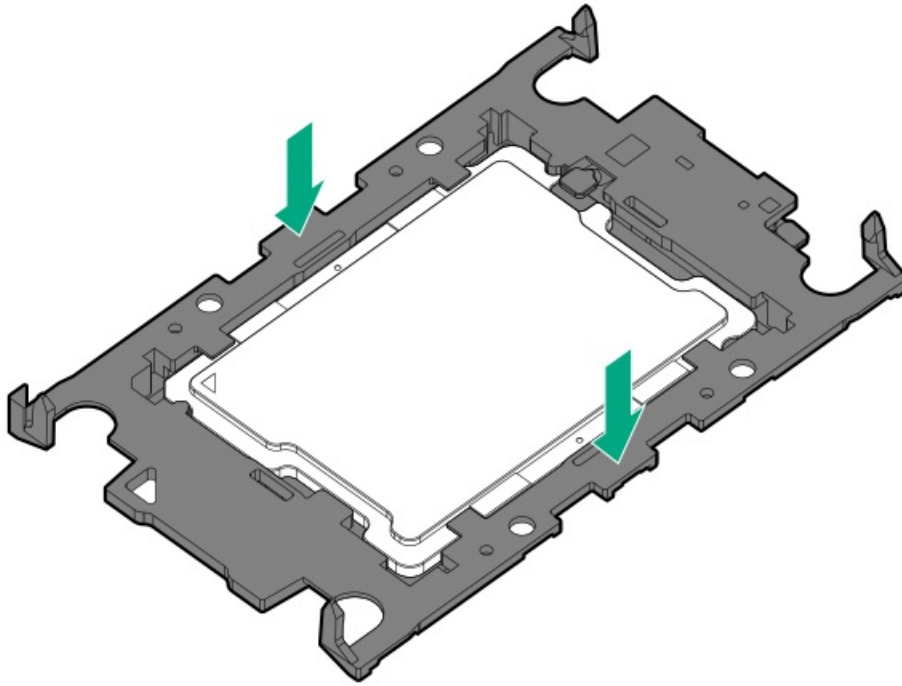

3. Remove the protective film from the thermal interface material.



CAUTION

To prevent mechanical damage or depositing oil on your hands or other contaminants to the heatsink contact surface, hold the heatsink only by the edge of its base plate. Do not touch the heatsink fins.

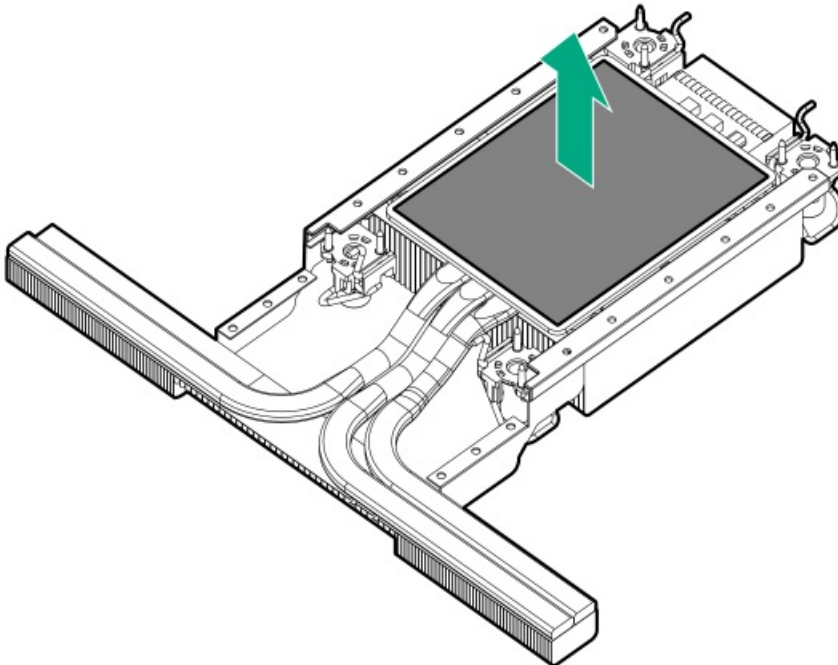

4. Set the anti-tilt wires to the locked position.

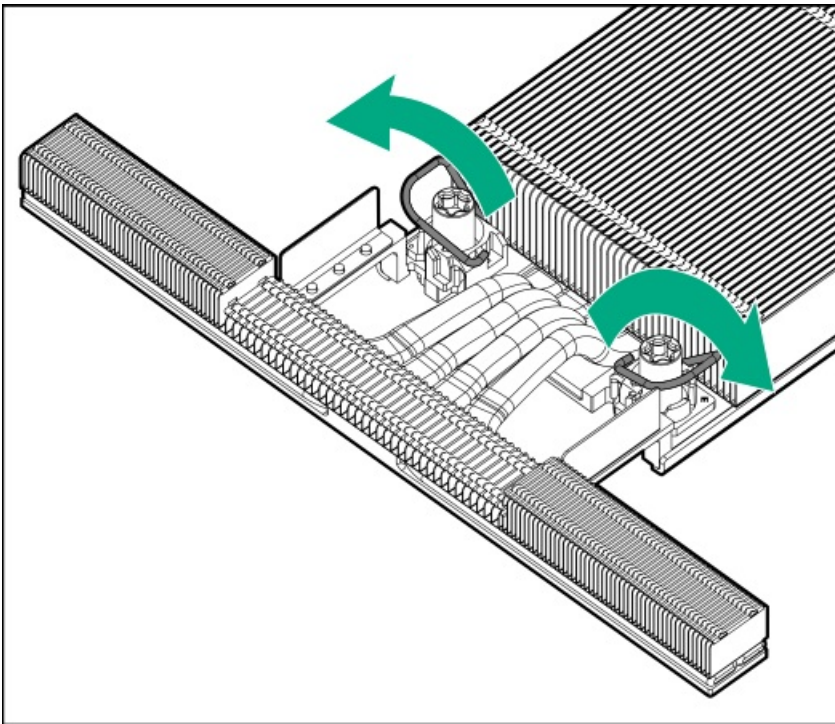

5. Attach the heatsink to the processor carrier:

- a. Align the pin 1 indicator on the processor carrier with that on the heatsink.

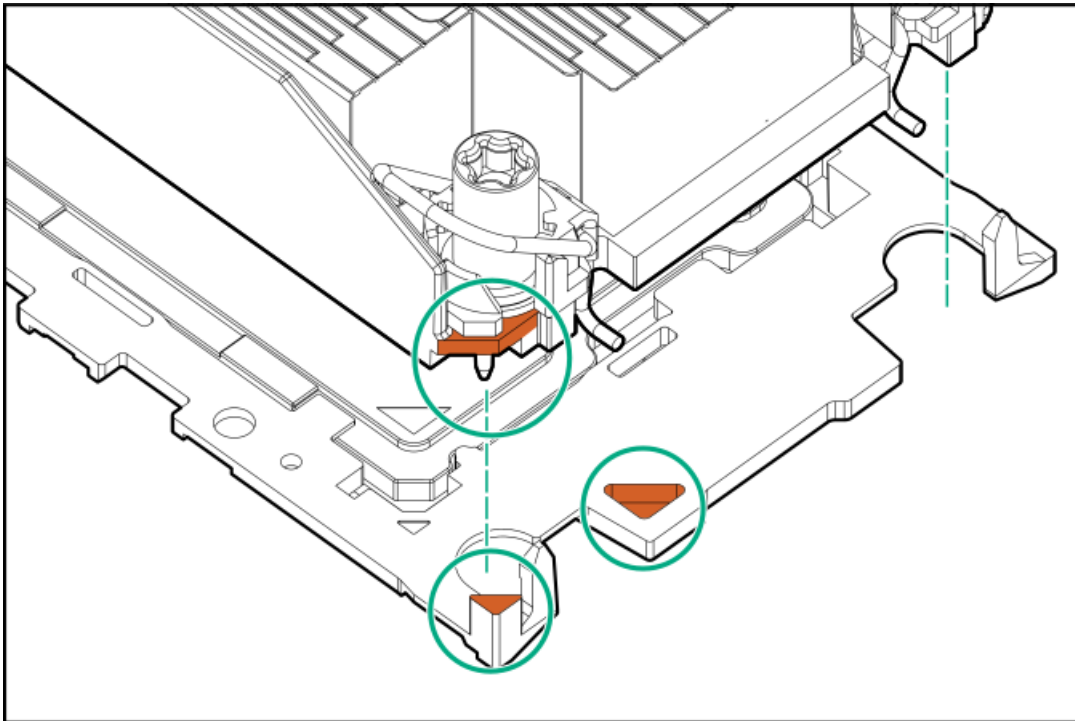

- b. Lower the heatsink on the processor carrier until the carrier tabs snap into place.

There will be an audible click to indicate that the heatsink is properly latched on the processor carrier.

- Standard heatsink



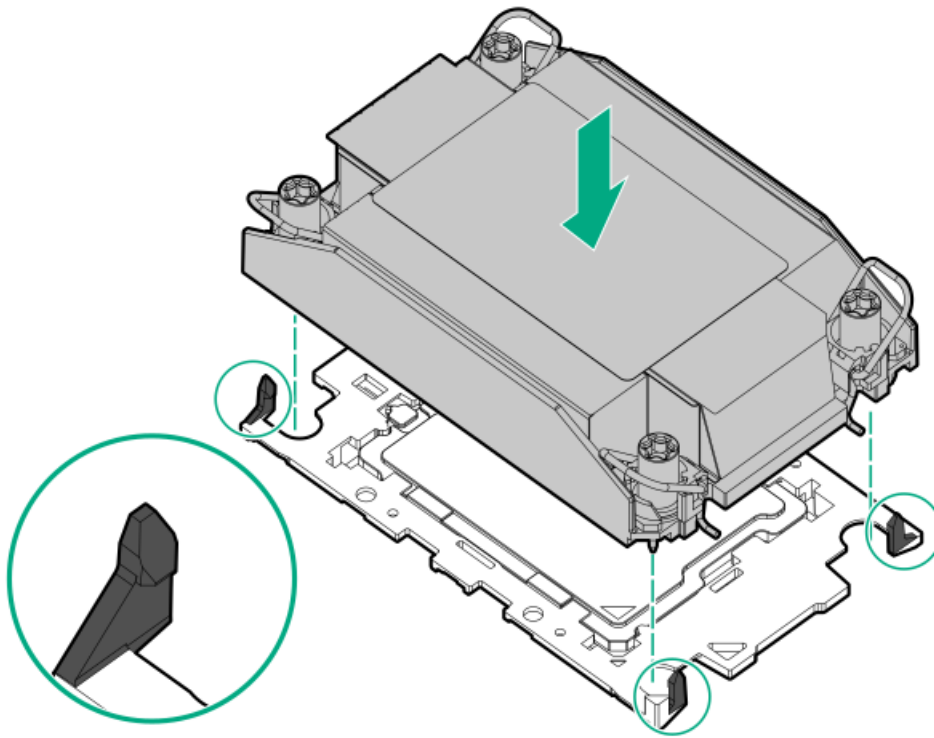

- Performance heatsink

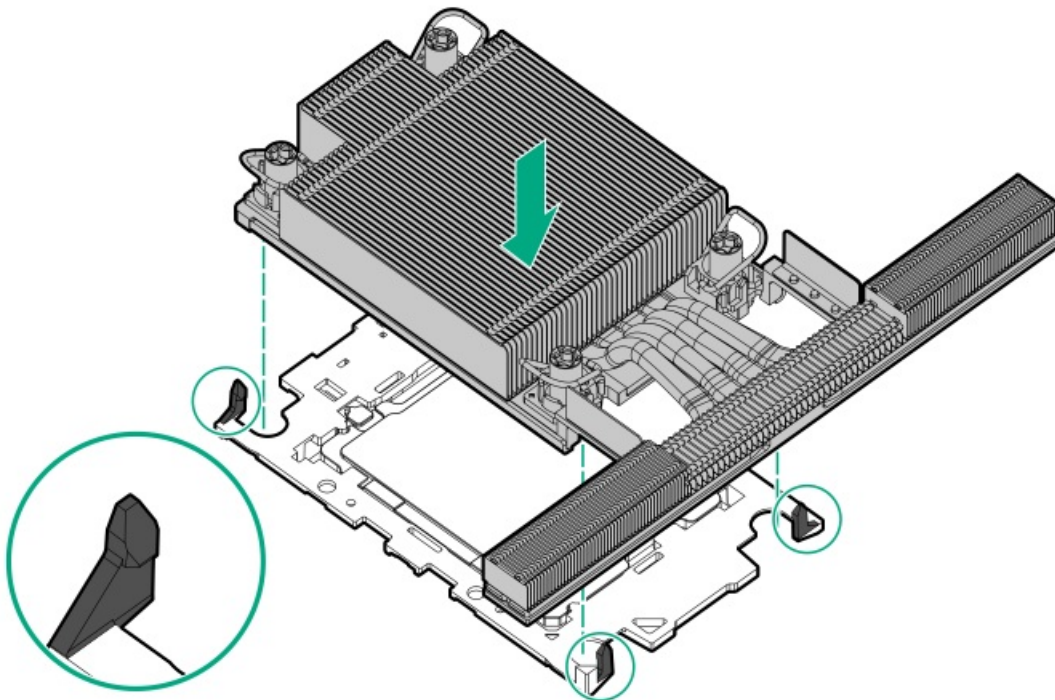

6. Perform the following verification steps:

- a. Verify that the tabs on the processor carrier are securely latched on the heatsink.



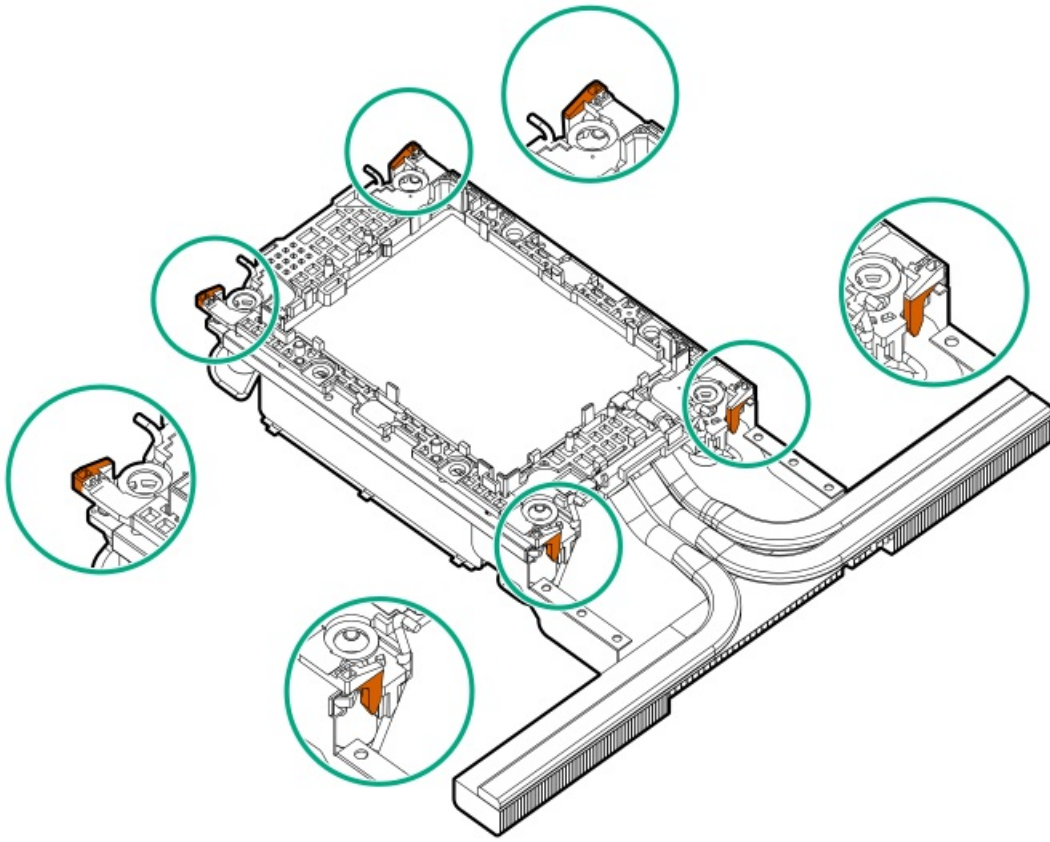

b. Verify that the pin 1 indicators on the processor and processor carrier are aligned.

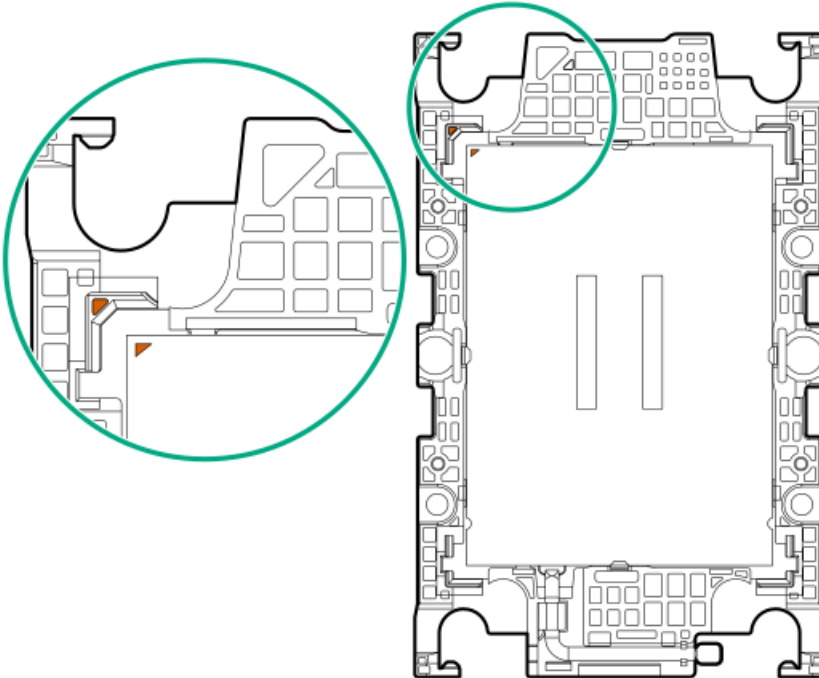

c. Verify that the processor is properly secured by the carrier snaps.



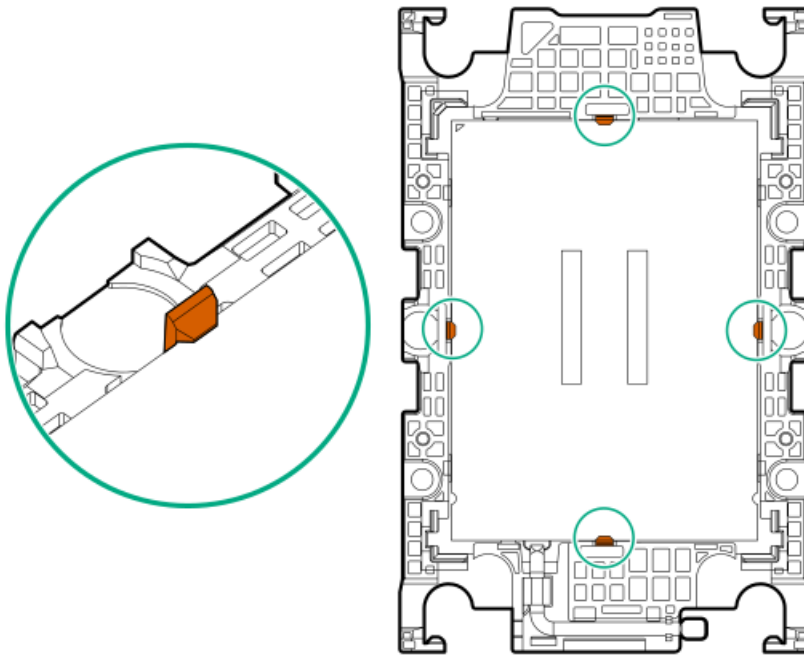

7.  **CAUTION**

To prevent thermal failure or component damage, do not move the heatsink once the bottom of its base plate touches the top of the processor. Excessive heatsink movement can cause the thermal grease to smear and become uneven. Voids in the compound can adversely impact the transfer of heat away from the processor.

Install the processor-heatsink module:

- a. When using a torque wrench to tighten the heatsink screws, set 0.9 N-m (8 in-lb) of torque .
- b. Note the **Front of server** text on the heatsink label to correctly orient the processor-heatsink module over the bolster plate.
- c. Carefully lower the processor-heatsink module straight down onto the bolster plate guide posts.

The posts are keyed so that the module can only be installed one way. Make sure that the module is properly seated on the bolster plate before securing the screws

- Standard heatsink

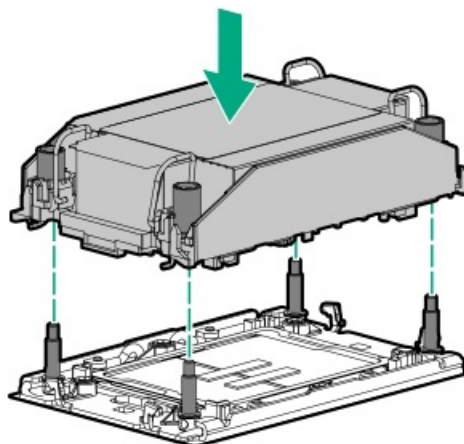

- Performance heatsink

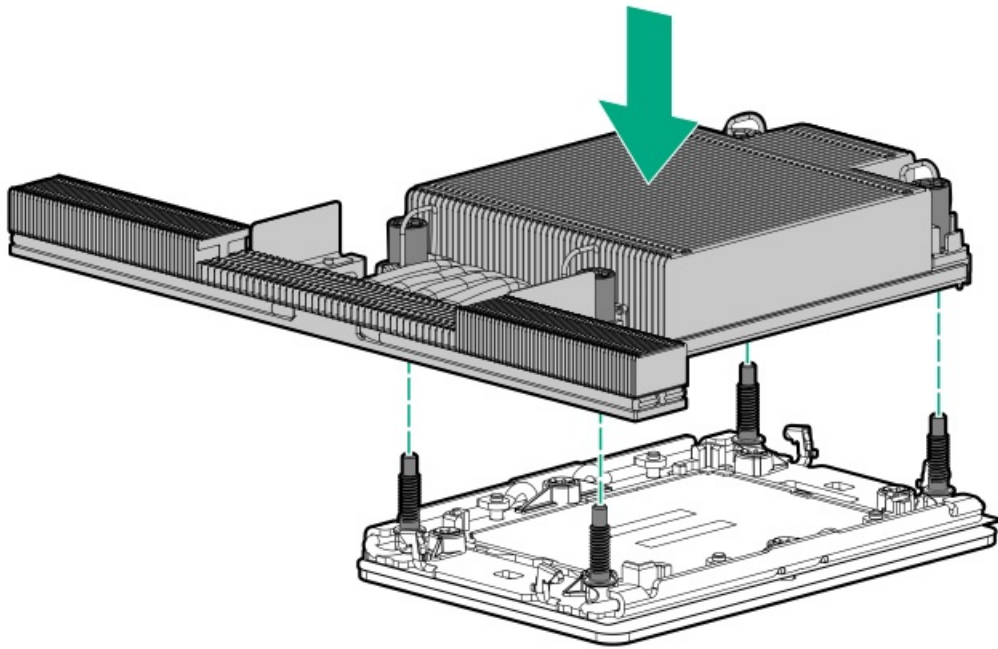

d. Set the anti-tilt wires to the locked position:

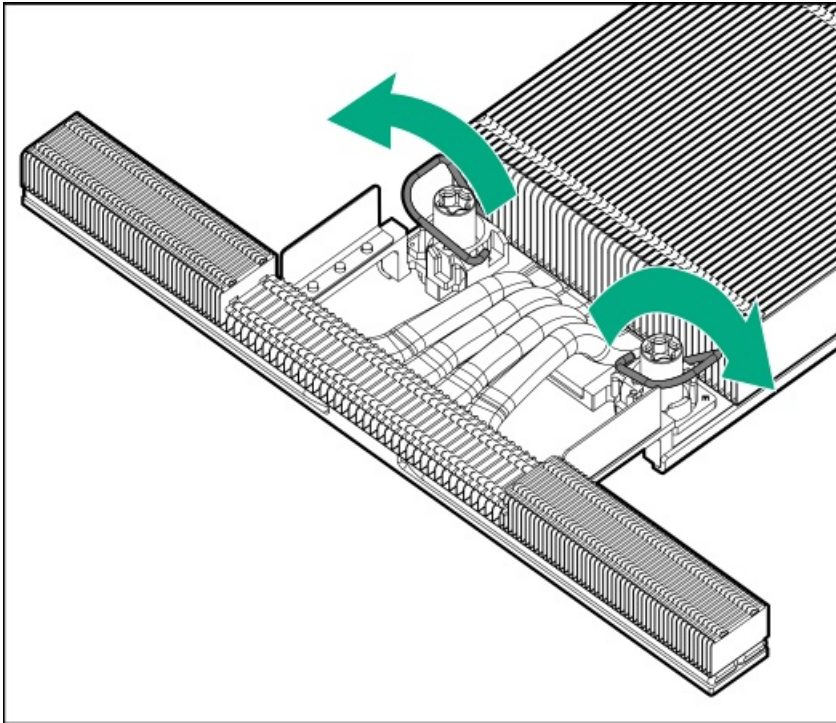

e. Tighten one pair of diagonally opposite heatsink screws, and then tighten the other pair of heatsink screws.

- Standard heatsink

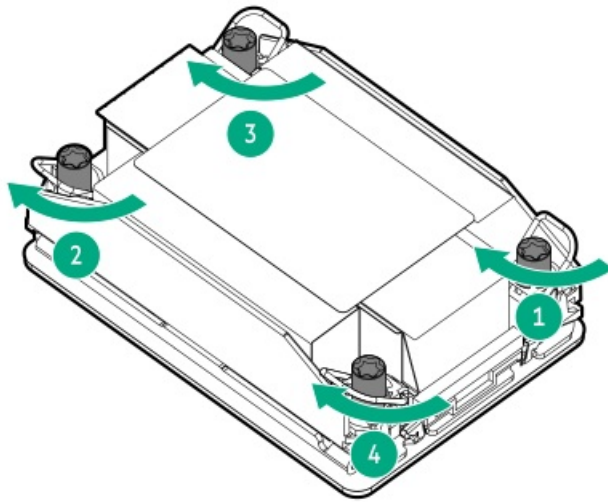

- Performance heatsink

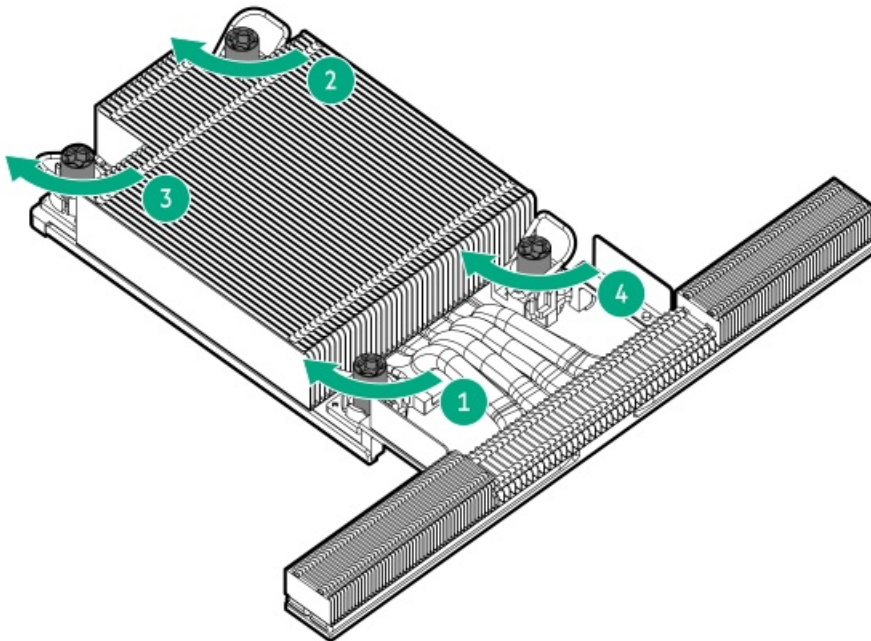

8. Install the access panel.
9. Install the server into the rack.
10. Connect all peripheral cables to the server.
11. Connect the power cords:
 - a. Connect each power cord to the server.
 - b. Connect each power cord to the power source.
12. Power up the server.

Results

The replacement procedure is complete.

Installing a closed-loop liquid cooling heatsink

About this task



IMPORTANT

This part is not customer serviceable. Parts identified as "No" in the [Illustrated Parts Catalog](#) are not designed for customer self-repair. To satisfy the customer warranty, Hewlett Packard Enterprise requires that an authorized service provider replace the part. If you suspect a failure, leave the part installed and contact a Hewlett Packard Enterprise authorized service provider.

Processor replacement

Subtopics

[Processor cautions](#)

[Removing the processor](#)

[Installing the processor](#)

Processor cautions



CAUTION

To avoid damage to the processor or system board, only authorized personnel should attempt to replace or install the processor in this server.



CAUTION

To prevent possible server malfunction and damage to the equipment, multiprocessor configurations must contain processors with the same part number.



CAUTION

The pins on the processor socket and on the processor are very fragile and easily damaged . To avoid component damage, do not touch these pins. Any damage to them might require replacing the system board and/or processor.



IMPORTANT

Processor socket 1 must be populated at all times or the server does not function.



IMPORTANT

If installing a processor with a faster speed, update the system ROM before installing the processor. To download firmware, see [Updating firmware and system ROM](#).

Removing the processor

Prerequisites



- Identify the heatsink and processor socket components.
- Review the processor cautions.
- Before you perform this procedure, make sure that you have the following items available:
 - T-30 Torx screwdriver
 - Alcohol wipe

Procedure

1. Power down the server.
2. If installed, release the cable management arm.
3. Remove all power:
 - a. Disconnect each power cord from the power source.
 - b. Disconnect each power cord from the server.
4. Disconnect all peripheral cables from the server.
5. Remove the server from the rack.
6. Place the server on a flat, level work surface.
7. Remove the access panel.
8. Allow all internal system components to cool before continuing.

9.  **CAUTION**
Heatsink screws must be tightened and loosened in alternating sequence. Do not overtighten the screws as this might damage the system board or the processor socket.

Use a T-30 Torx screwdriver to loosen one pair of diagonally opposite screws (callouts 1 and 2), and then loosen the other pair of screws (callouts 3 and 4).

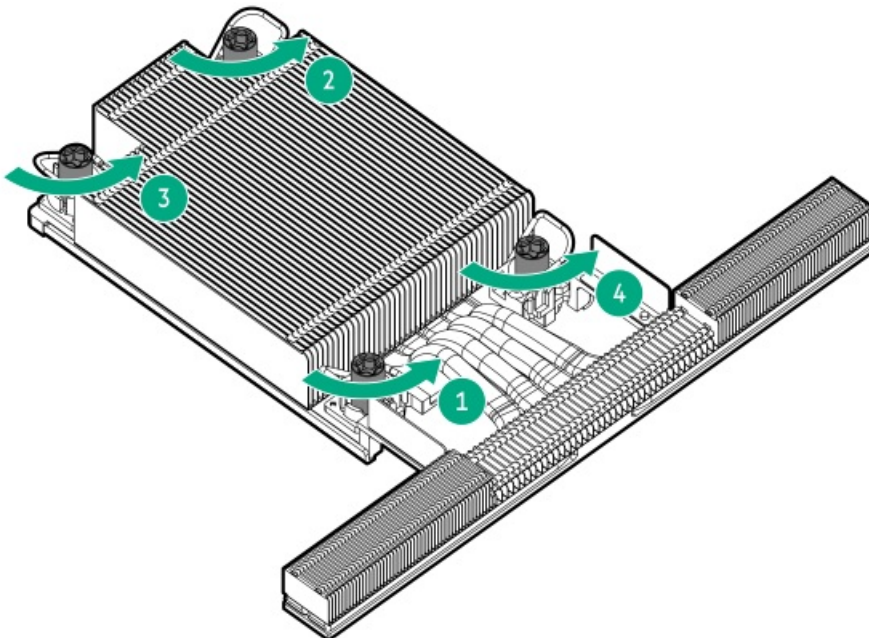

10. Set the anti-tilt wires to the unlocked position.

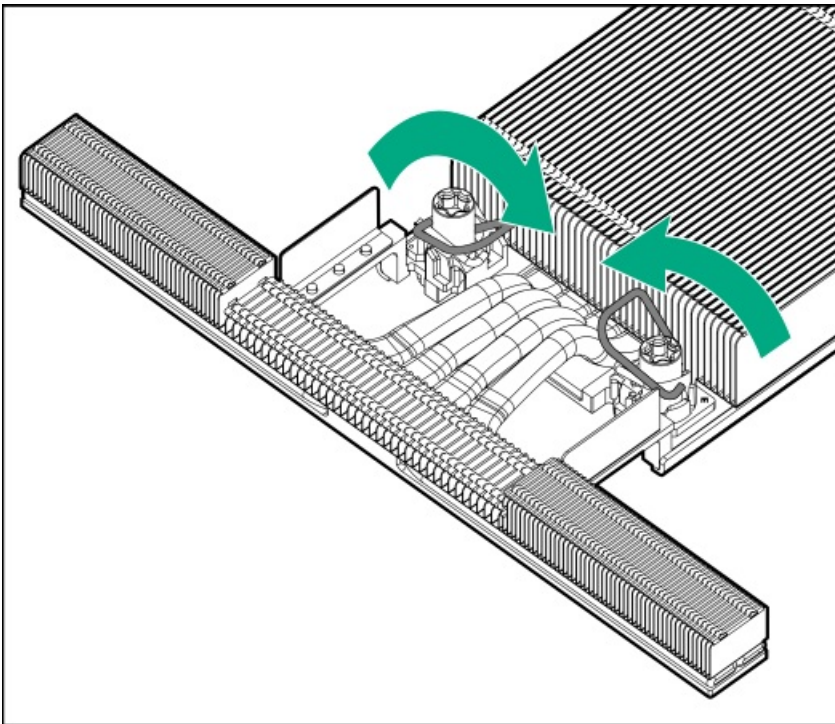

11.



CAUTION

To prevent mechanical damage or depositing oil on your hands or other contaminants to the heatsink contact surface, hold the heatsink only by the edge of its base plate. Do not touch the heatsink fins.

Lift the processor-heatsink module straight up from the system board.

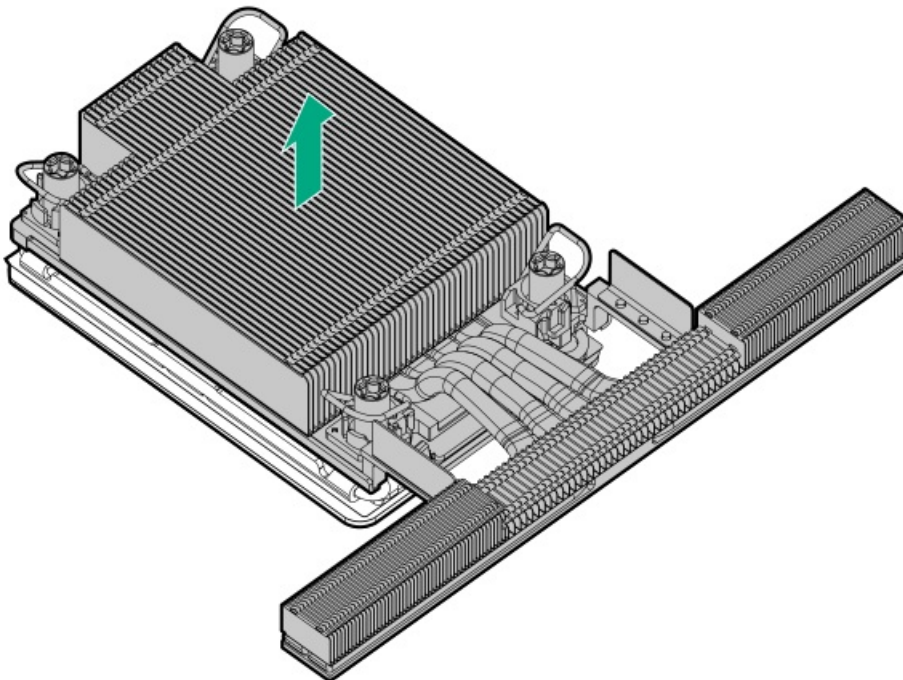

12. Set the anti-tilt wires to the locked position.



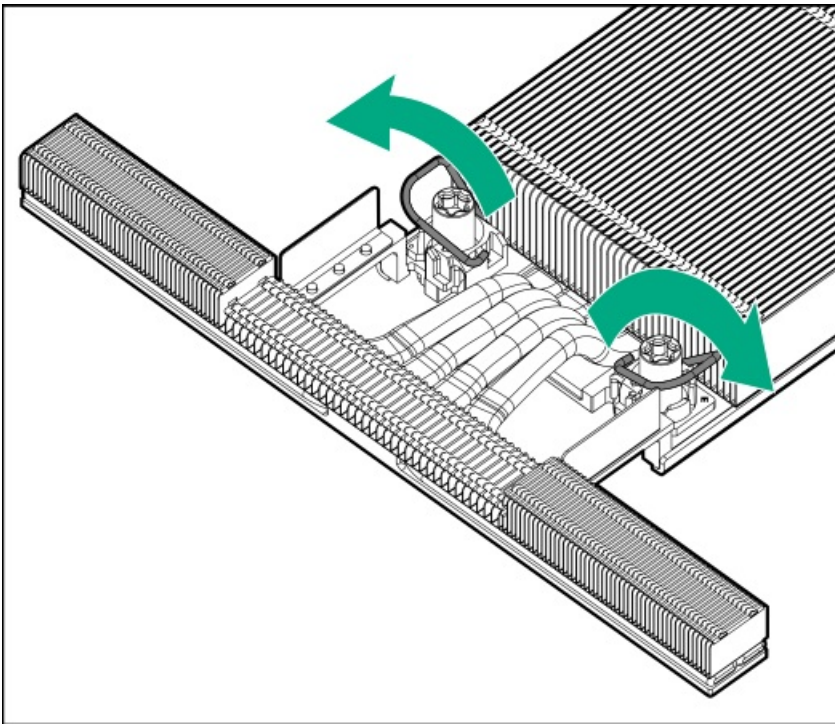

13. Place the processor-heat sink module on a flat work surface with its contact side facing up.
14. If you are not immediately installing the replacement processor-heat sink module, install the dust cover on the empty processor socket:



CAUTION

Do not press down on the dust cover. Pressing down on the dust cover might damage the processor socket.

- a. Press and hold the grip tabs on the dust cover.
- b. Carefully lower the dust cover onto the bolster plate guide posts.

Make sure that the corner holes of the dust cover are properly engaged with the guide posts on the bolster plate.

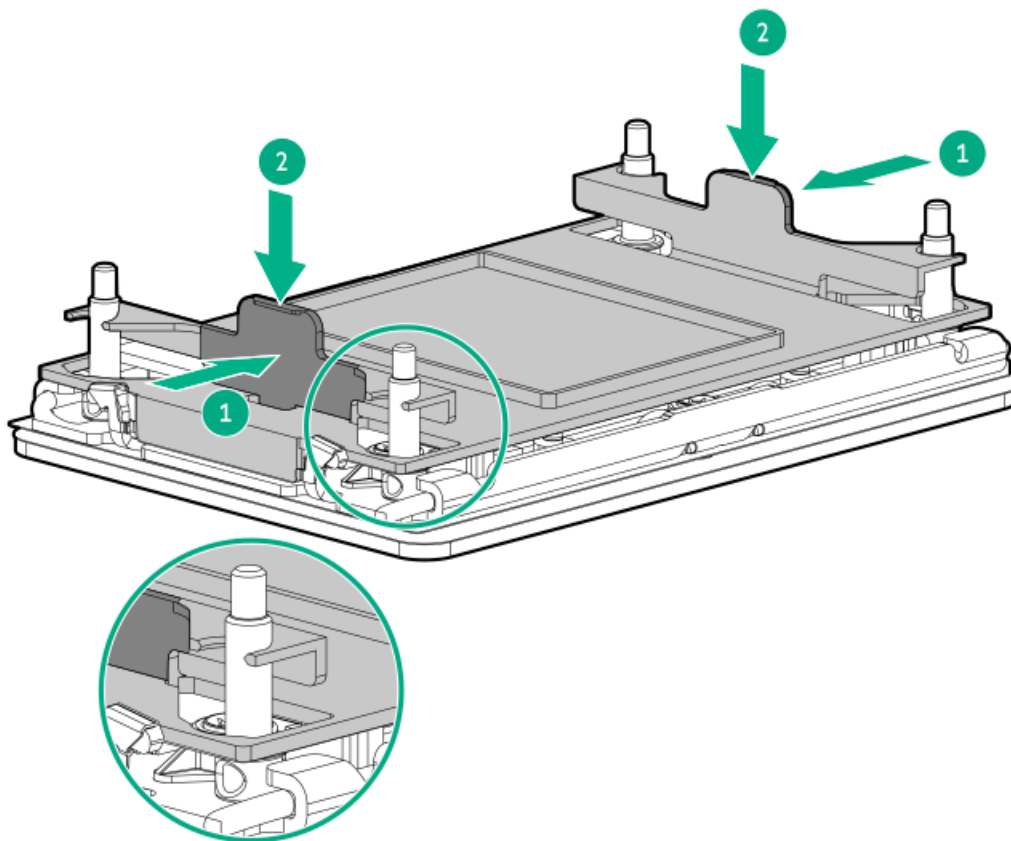

15. Do not touch the pins on the processor socket and the processor.



CAUTION

THE PINS ON THE PROCESSOR SOCKET AND ON THE PROCESSOR ARE VERY FRAGILE AND EASILY DAMAGED. Any damage to them might require replacing the system board.

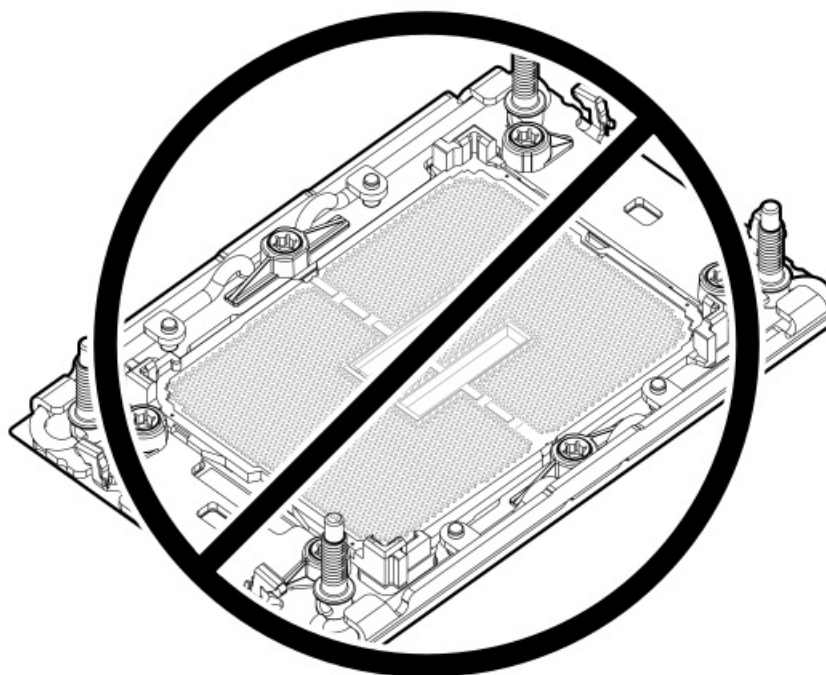

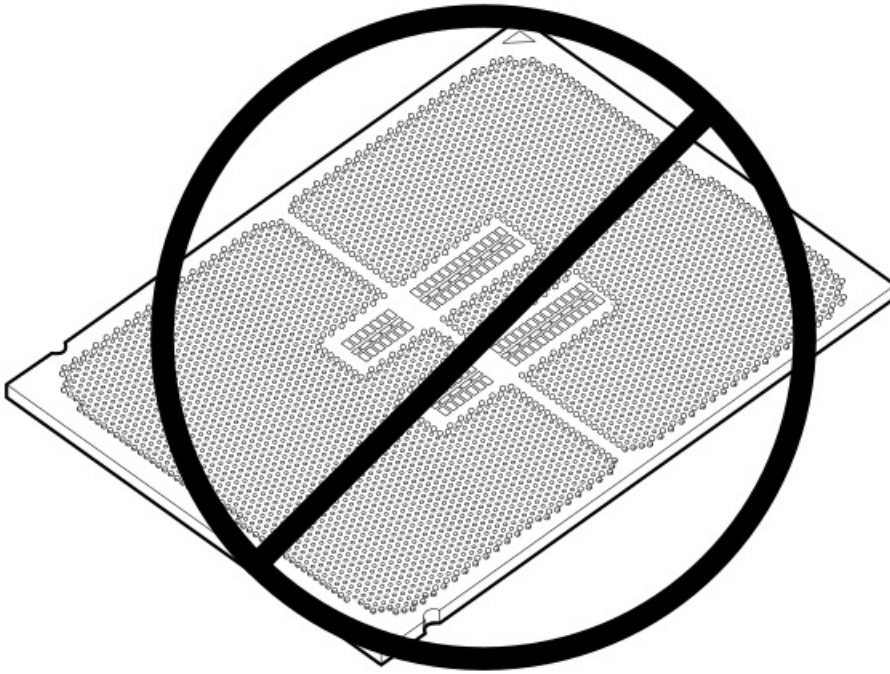

16. Remove the processor from the heatsink:

- a. Open the TIM breaker lever.

This action breaks the adhesion between the processor and the heatsink.

- b. Hold the processor on its edges, and then remove it from the carrier.

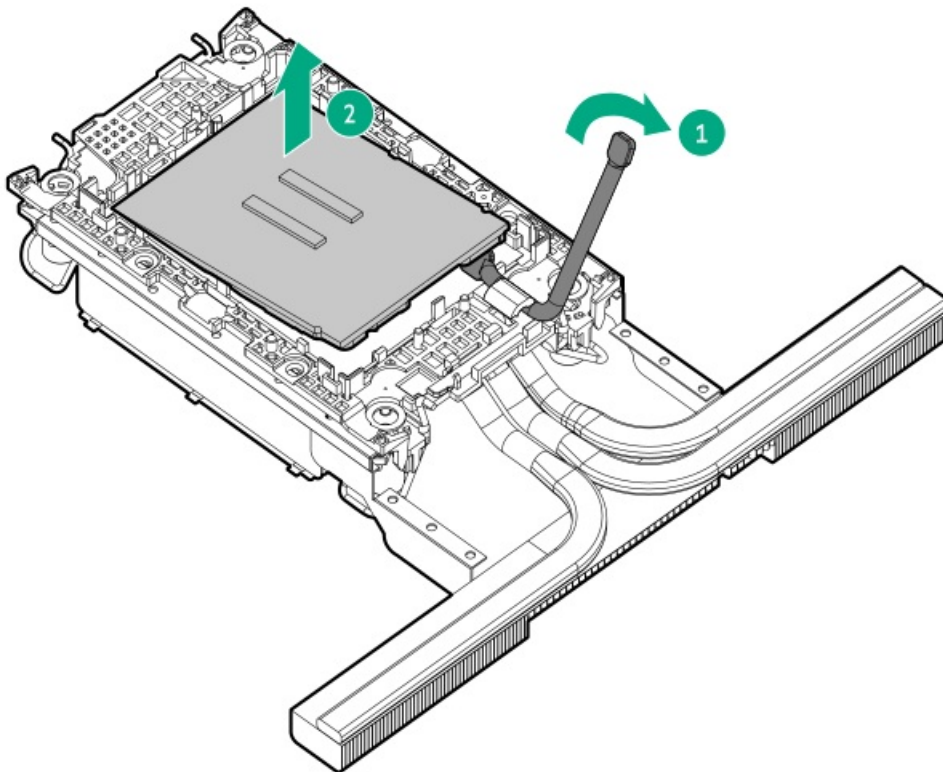

- c. Starting from the pin 1 corner and moving in an opposite manner, disengage the processor carrier release tabs from the heatsink.



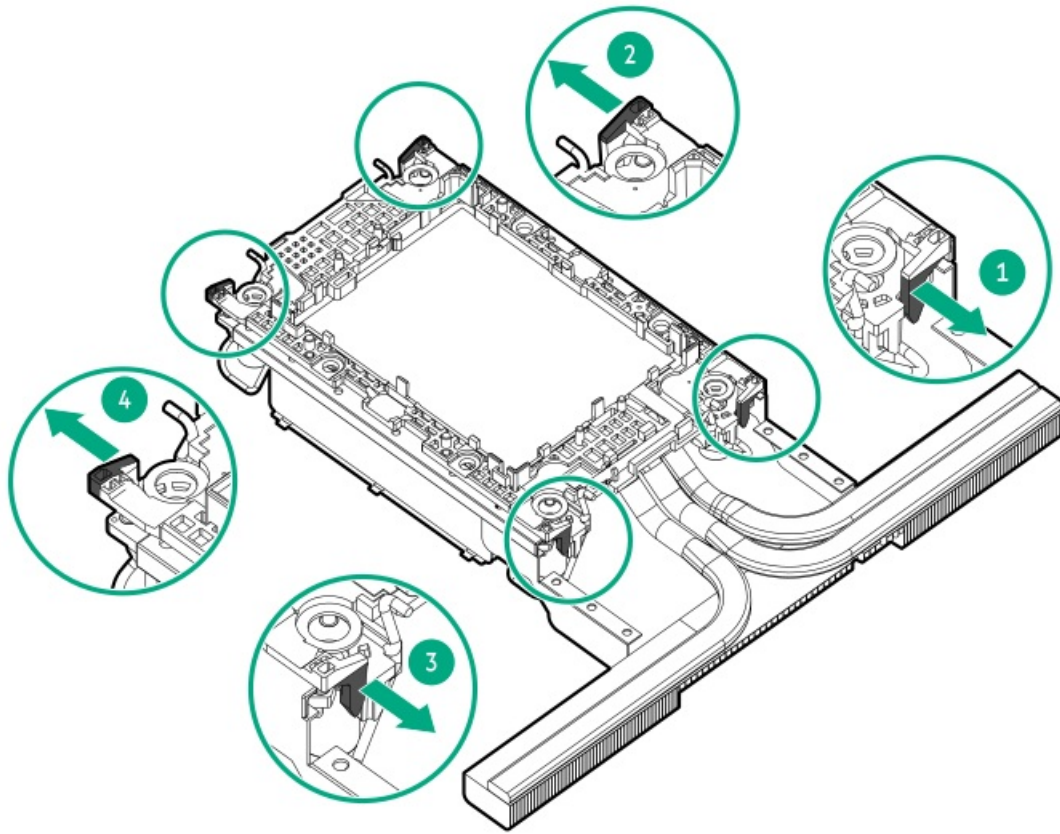

d. Lift the processor carrier away from the heatsink.

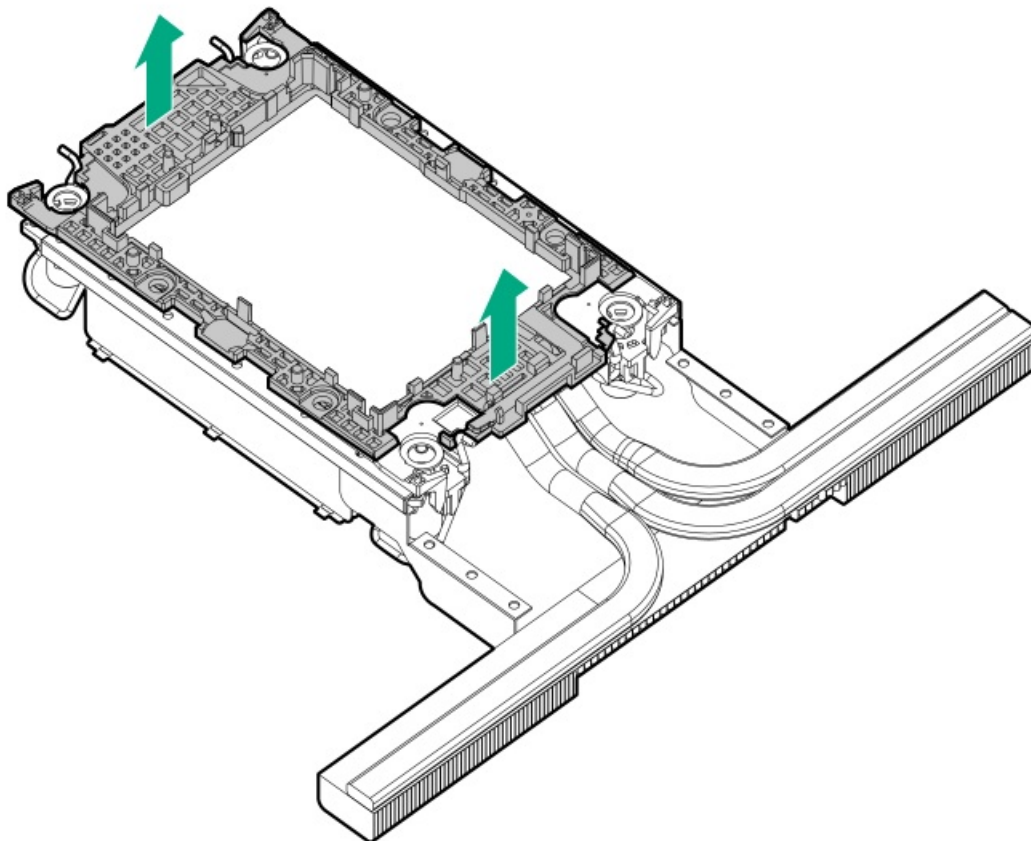

17. Use an alcohol wipe to remove the existing thermal grease from the heatsink and processor.



Allow the alcohol to evaporate before continuing.

Installing the processor

Prerequisites

- [Identify the heatsink and processor socket components.](#)
- [Review the processor cautions.](#)
- Before you perform this procedure, make sure that you have the following items available:
 - T-30 Torx screwdriver
 - 1.0 gm (0.5 ml) or two 0.5 gm (0.25 ml) of thermal grease

Procedure

1. If you are using the same heatsink, apply the full content of the thermal grease syringes on top of the processor. Follow the pattern shown in the following image.

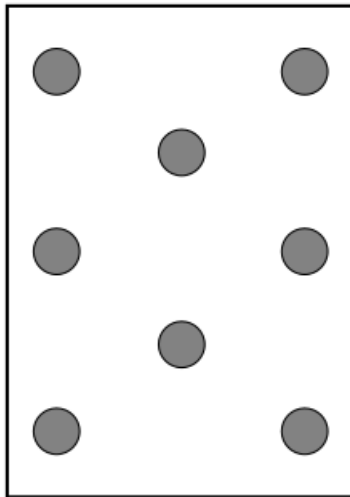

2. If you are using a new heatsink, remove the protective film from the thermal interface material.

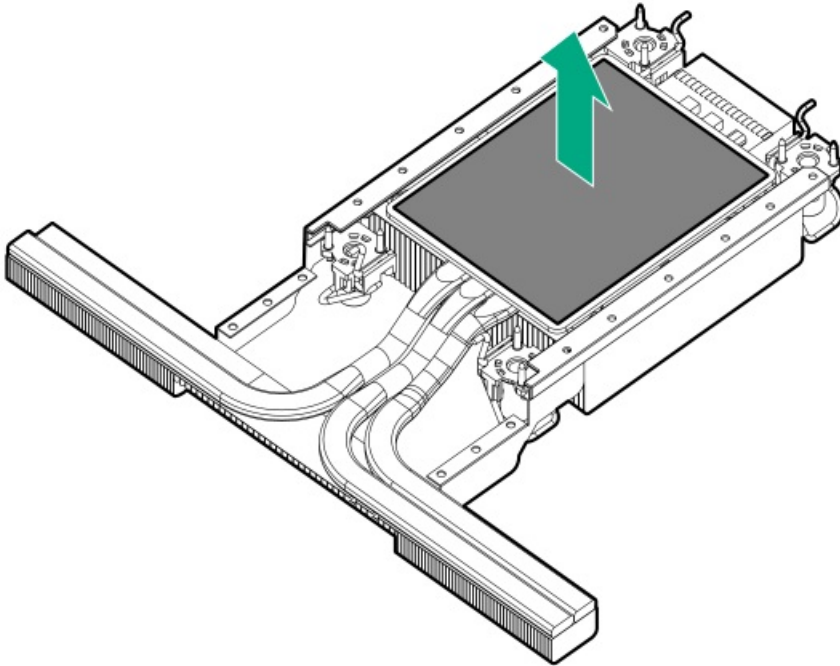

3. Set the anti-tilt wires to the locked position.

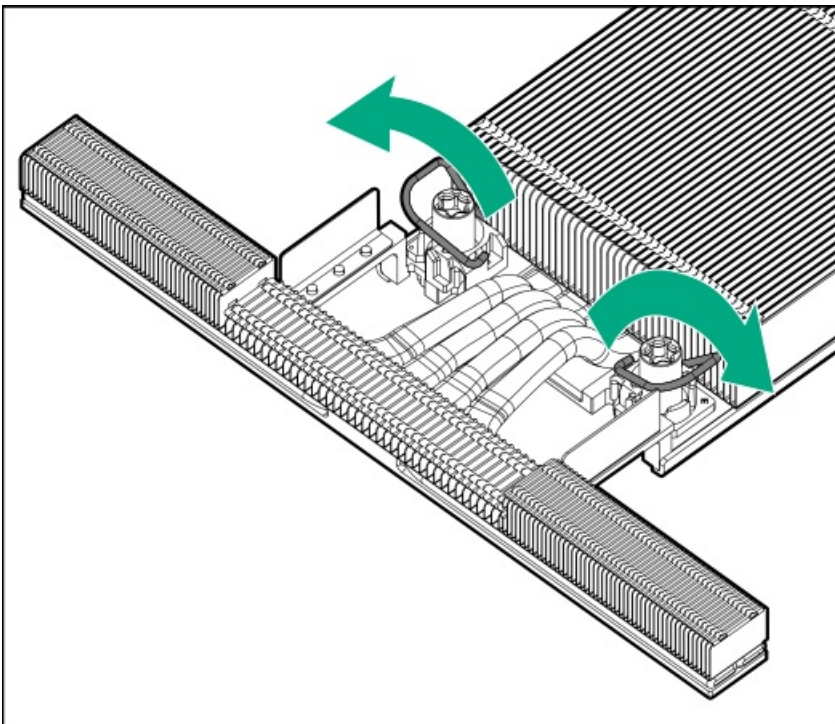

4. Verify that the processor is securely latched to the processor carrier.

The following illustration calls out the keying feature tabs that secure the processor. Different processor carriers will have these tabs in different locations.



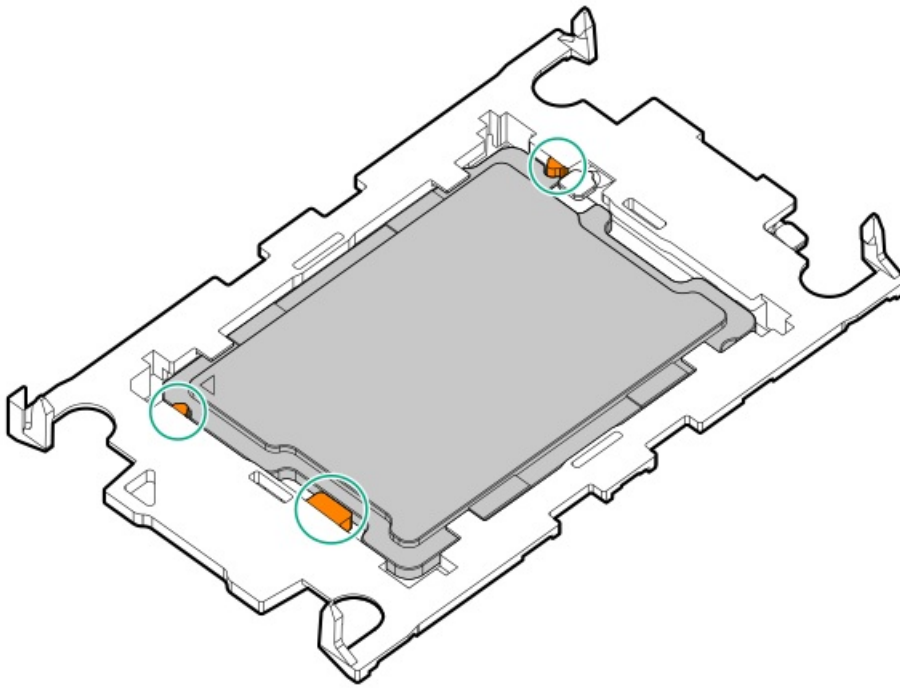

5. Attach the heatsink to the processor carrier:

- a. Align the pin 1 indicator on the processor carrier with that on the heatsink.

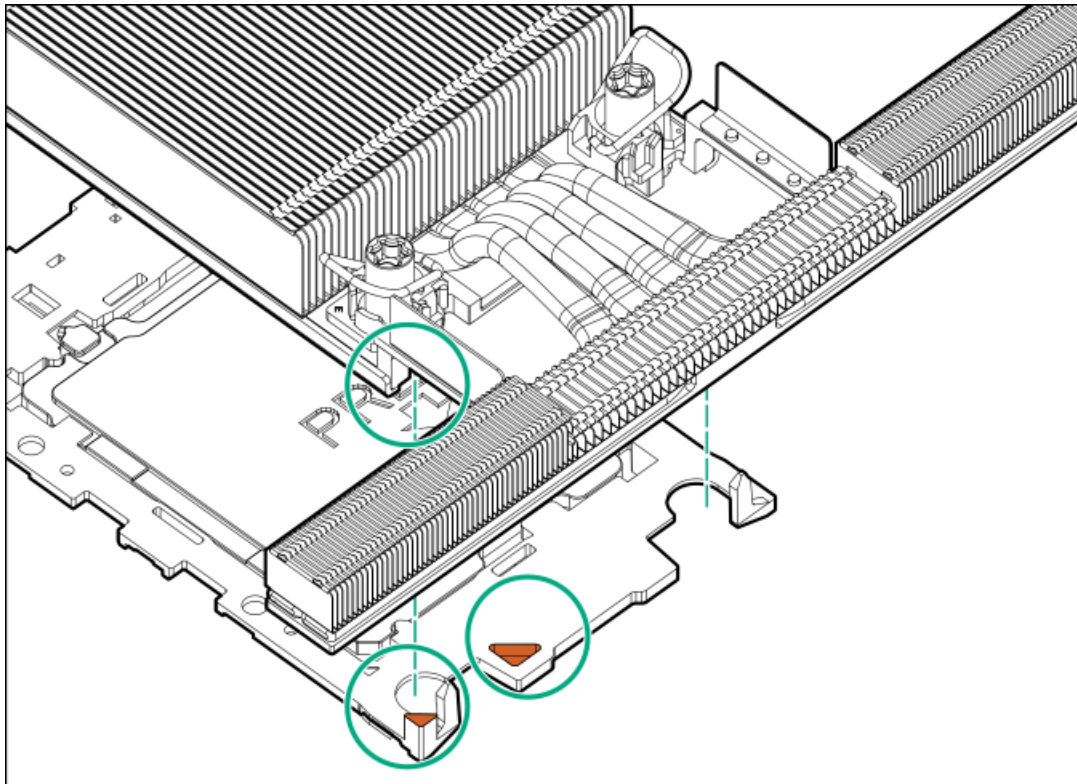

- b. Lower the heatsink on the processor carrier until the carrier tabs snap into place.

There will be an audible click to indicate that the heatsink is properly latched on the processor carrier.



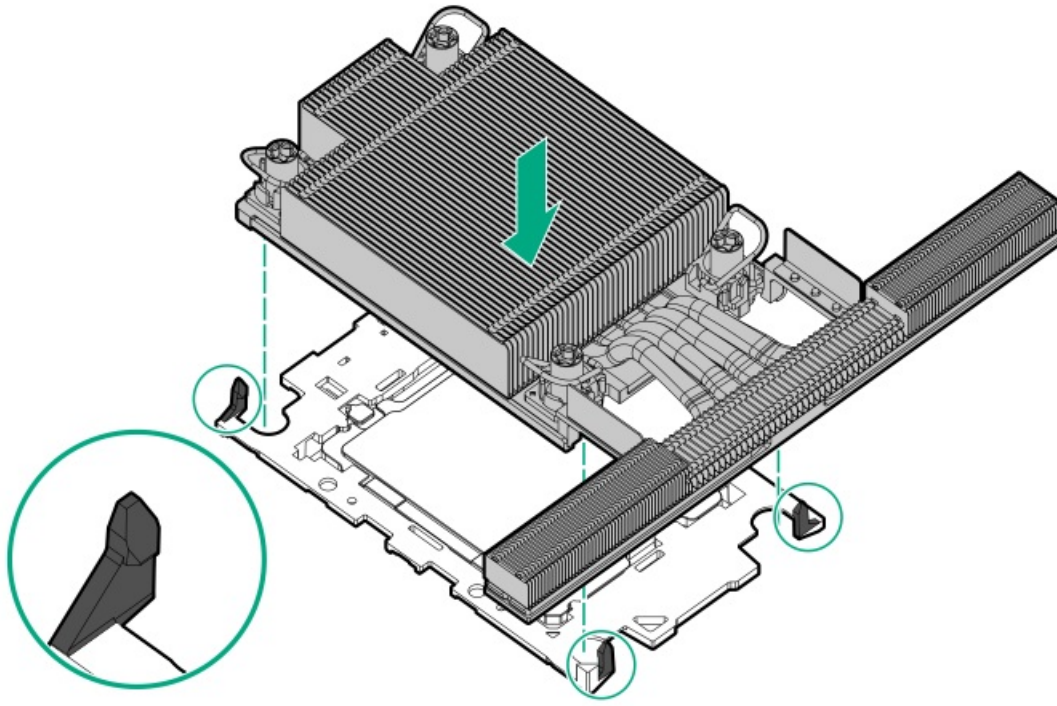

6. Perform the following verification steps:

- a. Verify that the tabs on the processor carrier are securely latched on the heatsink.

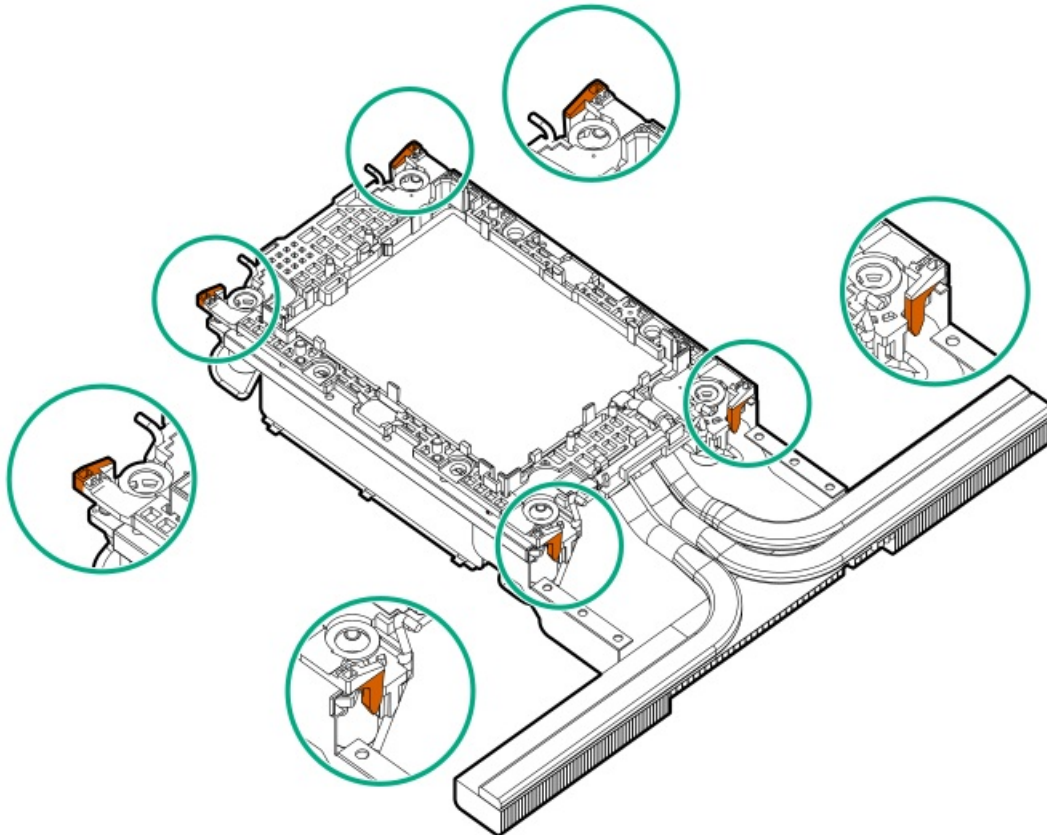

- b. Verify that the pin 1 indicators on the processor and processor carrier are aligned.



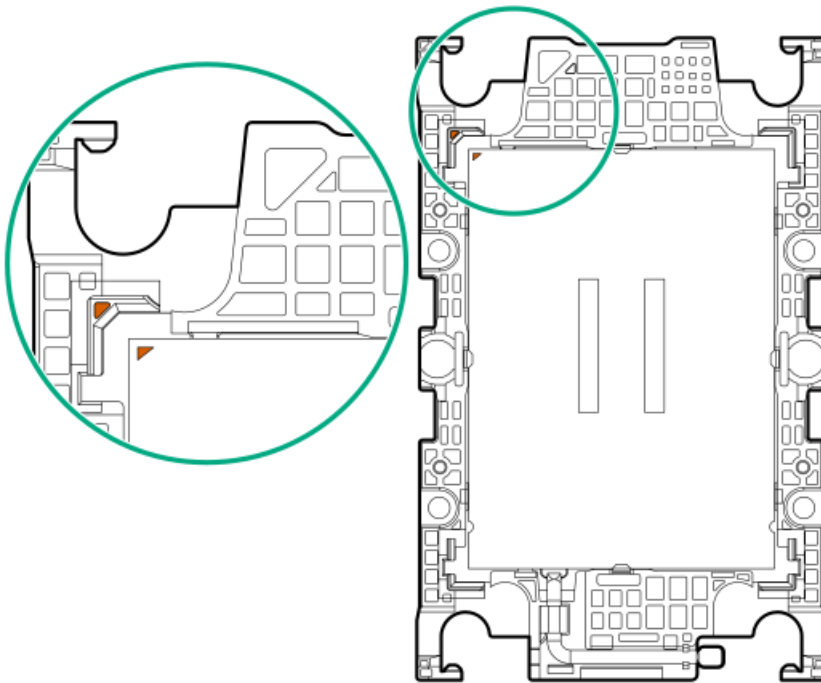

c. Verify that the processor is properly secured by the carrier snaps.

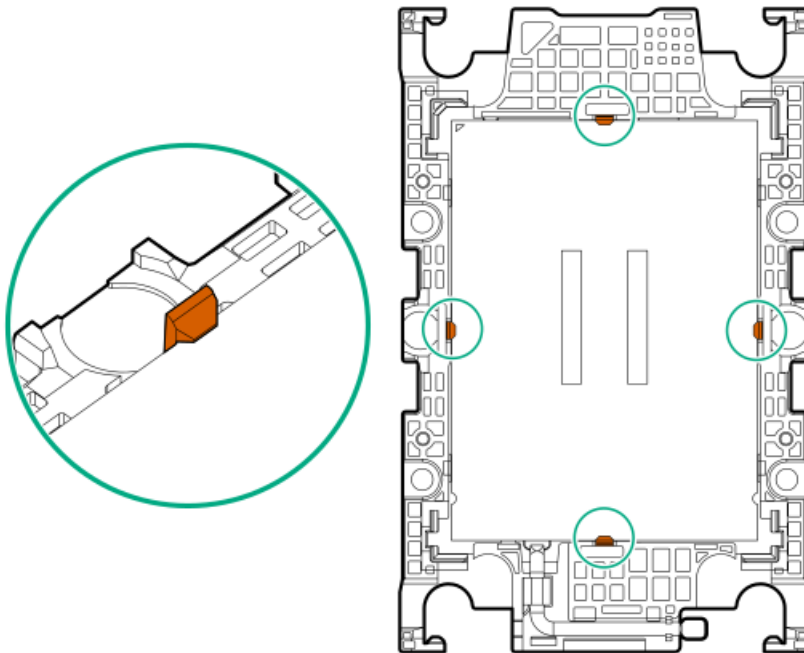

7. Install the processor-heatsink module:



CAUTION

To prevent mechanical damage or depositing oil on your hands or other contaminants to the heatsink contact surface, hold the heatsink only by the edge of its base plate. Do not touch the heatsink fins.



CAUTION

To prevent thermal failure or component damage, do not move the heatsink once the bottom of its base plate touches the top of the processor. Excessive heatsink movement can cause the thermal grease to smear and become uneven. Voids in the compound can adversely impact the transfer of heat away from the processor.

- a. When using a torque wrench to tighten the heatsink screws, set it to 0.9 N-m (8 in-lb) of torque.
- b. Note the **Front of server** text on the heatsink label to correctly orient the processor-heatsink module over the bolster plate.
- c. Carefully lower the processor-heatsink module straight down onto the bolster plate guide posts.

The posts are keyed so that the module can only be installed one way. Make sure that the module is properly seated on the bolster plate before securing the screws.

- d. Set the anti-tilt wires to the locked position.

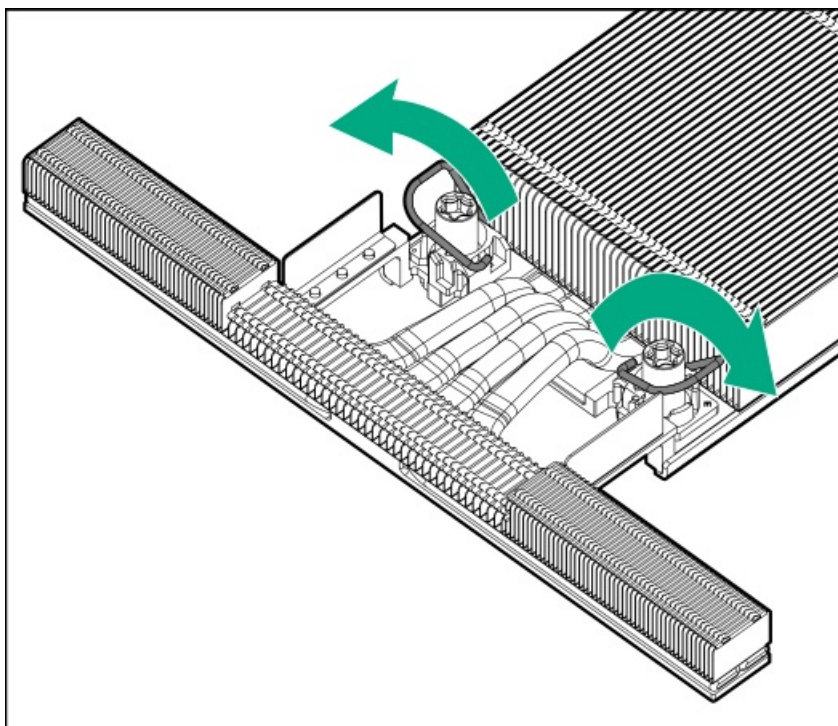

- e. Use a T-30 Torx screwdriver to tighten one pair of diagonally opposite heatsink screws (callouts 1 to 2), and then tighten the other pair of heatsink screws (callouts 3 to 4).

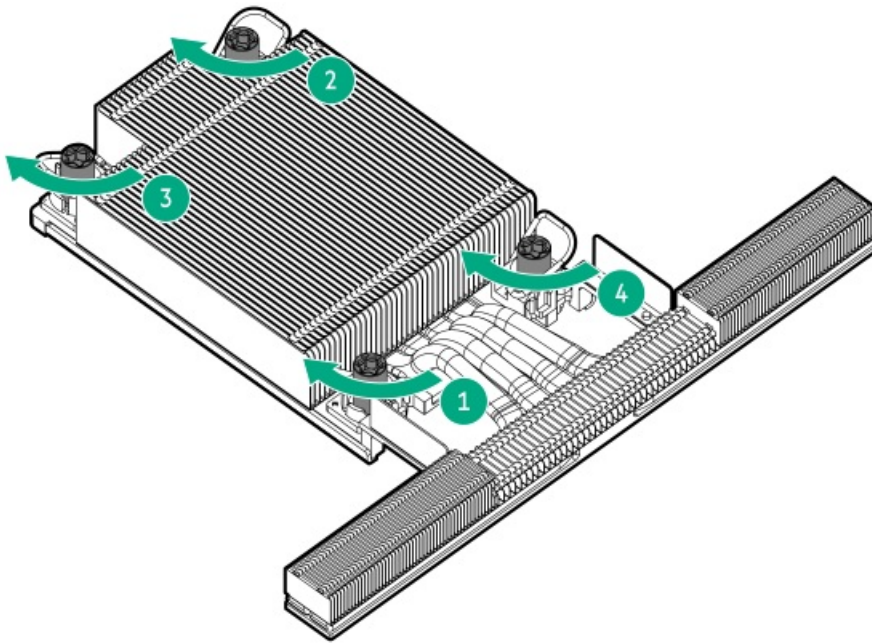

8. Set the anti-tilt wires to the locked position.

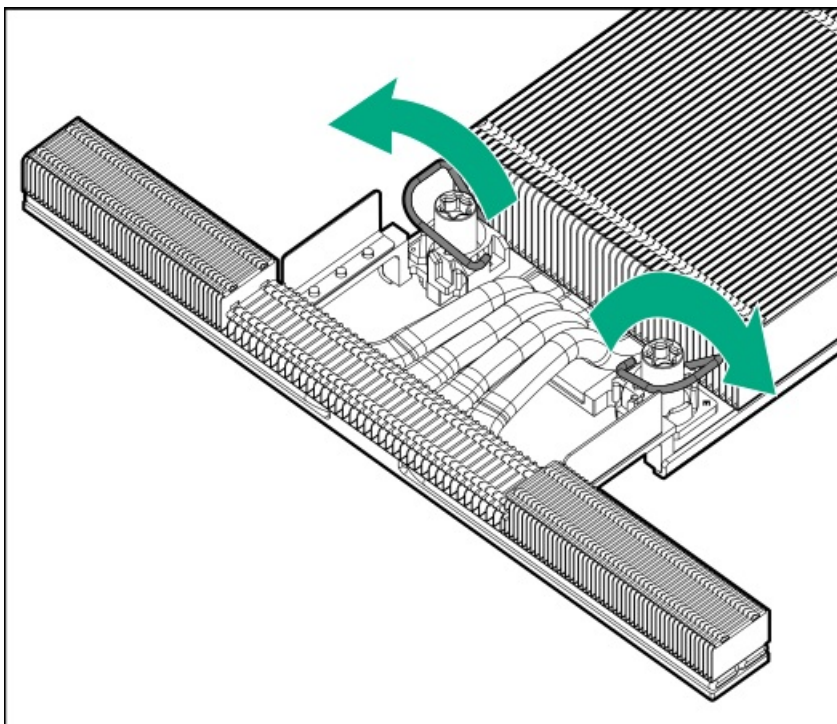

9. Install the access panel.

10. Install the server into the rack.

11. Connect all peripheral cables to the server.

12. Connect the power cords:

a. Connect each power cord to the server.

b. Connect each power cord to the power source.

13. Power up the server.

Results

The replacement procedure is complete.

System board replacement

Subtopics

[Removing the system board](#)

[Installing the system board](#)

[Binding the DC-SCM with the HPM](#)

[Re-entering the server serial number and product ID](#)

Removing the system board

Prerequisites



CAUTION

Be sure to have the BitLocker recovery key/password prior to replacing the system board. If you do not have the key/password, you will need to reinstall the OS.

Before you perform this procedure, make sure that you have the following items available:

- T-10 Torx screwdriver
- T-15 Torx screwdriver
- T-30 Torx screwdriver
- Alcohol wipe

About this task

https://sketchfab.com/models/a52d50702b424793a6f75540cdc69468/embed?ui_infos=0&ui_watermark=0&ui_help=0&ui_vr=0&ui_settings=0&ui_inspector=0&ui_hint=2&ui_color=01a982&ui_theme=dark&autostart=1&camera=0&



CAUTION

A discharge of static electricity from a finger or other conductor might damage system boards or other static-sensitive devices. To prevent damage, observe [antistatic precautions](#).

Procedure

1. [Power down the server](#).
2. If installed, [release the cable management arm](#).
3. Remove all power:
 - a. Disconnect each power cord from the power source.
 - b. Disconnect each power cord from the server.
4. Disconnect all peripheral cables from the server.
5. [Remove the server from the rack](#).
6. Place the server on a flat, level work surface.

7. Remove the access panel.
8. Remove the middle cover.
9. Disconnect all cables and remove all components from the system board:
 - Fans
 - DIMM guards
 - DIMMs
 - Riser cages
10. If installed, remove the following components:
 - Chassis intrusion detection switch
 - Power distribution board
 - Energy pack bracket
 - Power supplies
 - HPE NS204i-u Boot Device V2
 - OCP NIC 3.0 adapter
 - Serial port cable
11. Remove the ix port cable clamp.

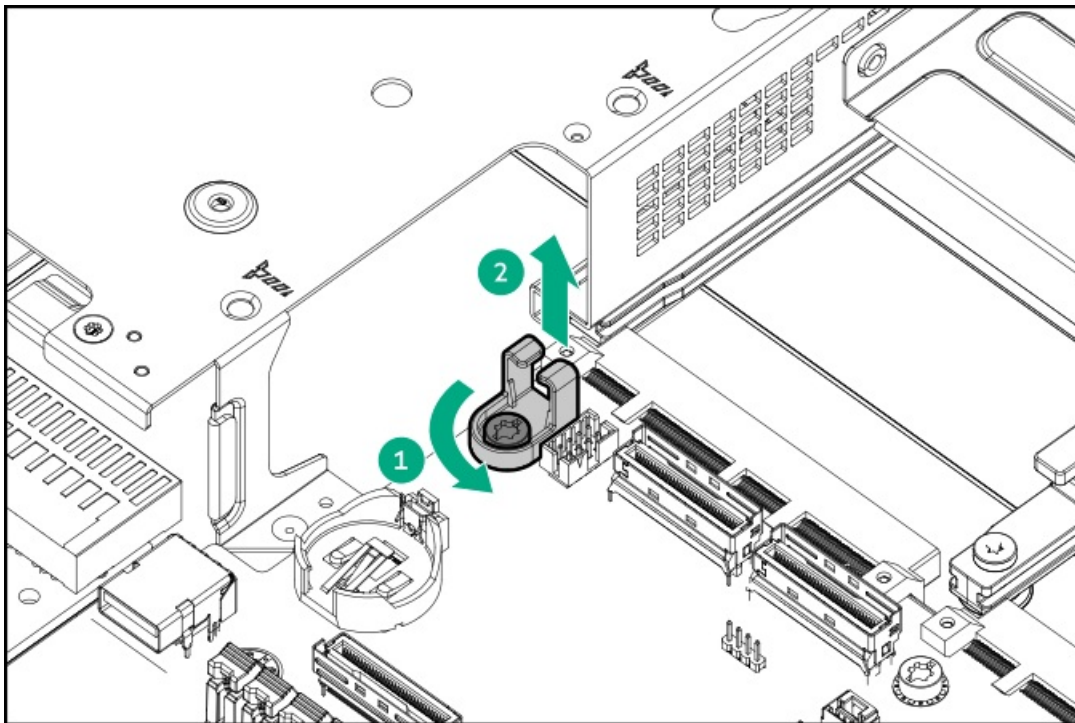

12. Allow all internal system components to cool before continuing.

13.  **CAUTION**

Heatsink screws must be tightened and loosened in alternating sequence. Do not overtighten the screws as this might damage the system board or the processor socket.

Use a T-30 Torx screwdriver to loosen one pair of diagonally opposite screws (callouts 1 and 2), and then loosen the other pair of screws (callouts 3 and 4).

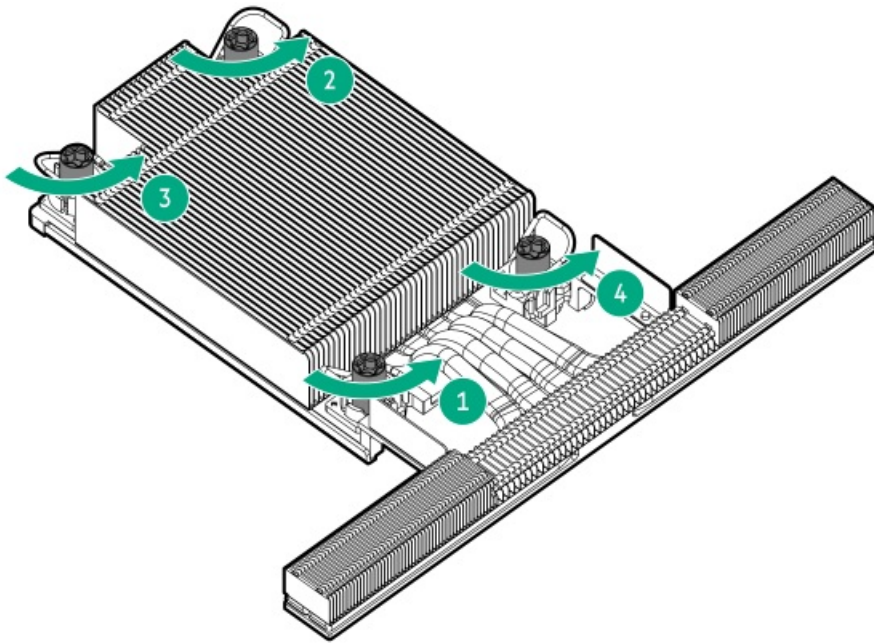

14.



CAUTION

To prevent mechanical damage or depositing oil on your hands or other contaminants to the heatsink contact surface, hold the heatsink only by the edge of its base plate. Do not touch the heatsink fins.

Lift the processor-heatsink module straight up from the system board.

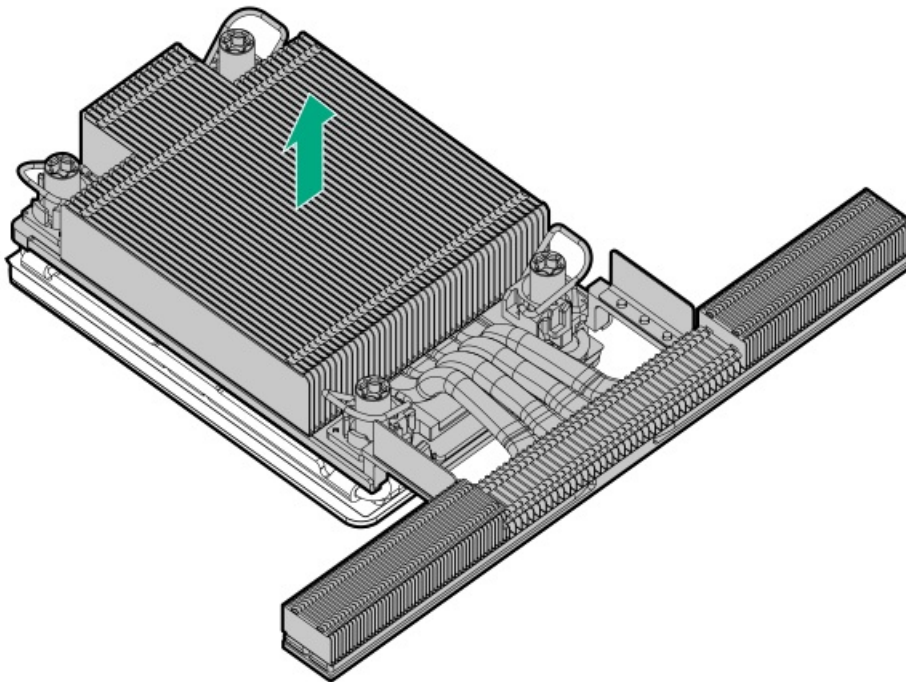

15. Set the anti-tilt wires to the locked position.



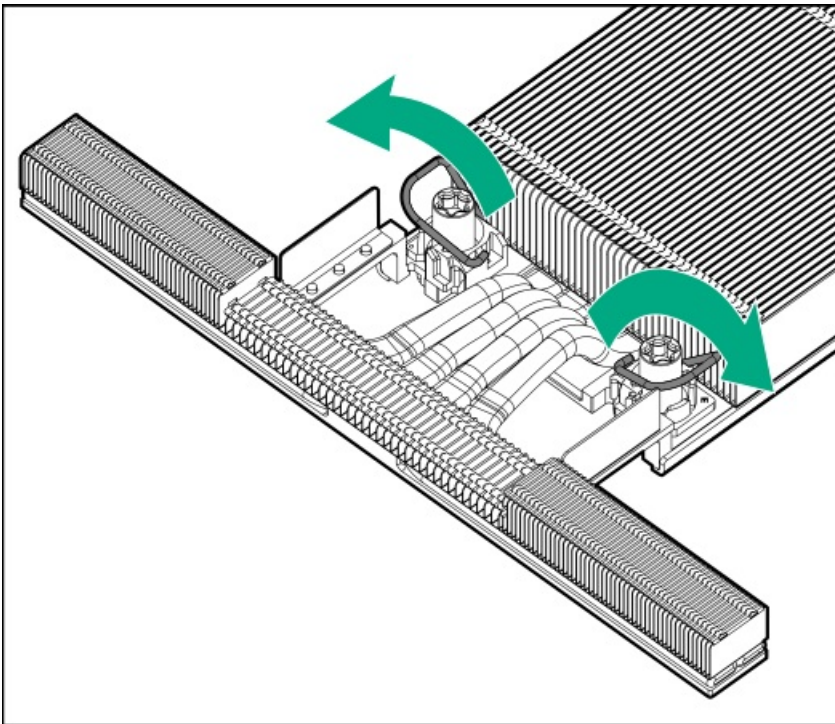

16. Place the processor-heatsink module on a flat work surface with its contact side facing up.
17. Remove the DC-SCM.
18. Remove the system board:
 - a. Remove the screws.
 - b. Lift up the system board to separate it from the base pan.

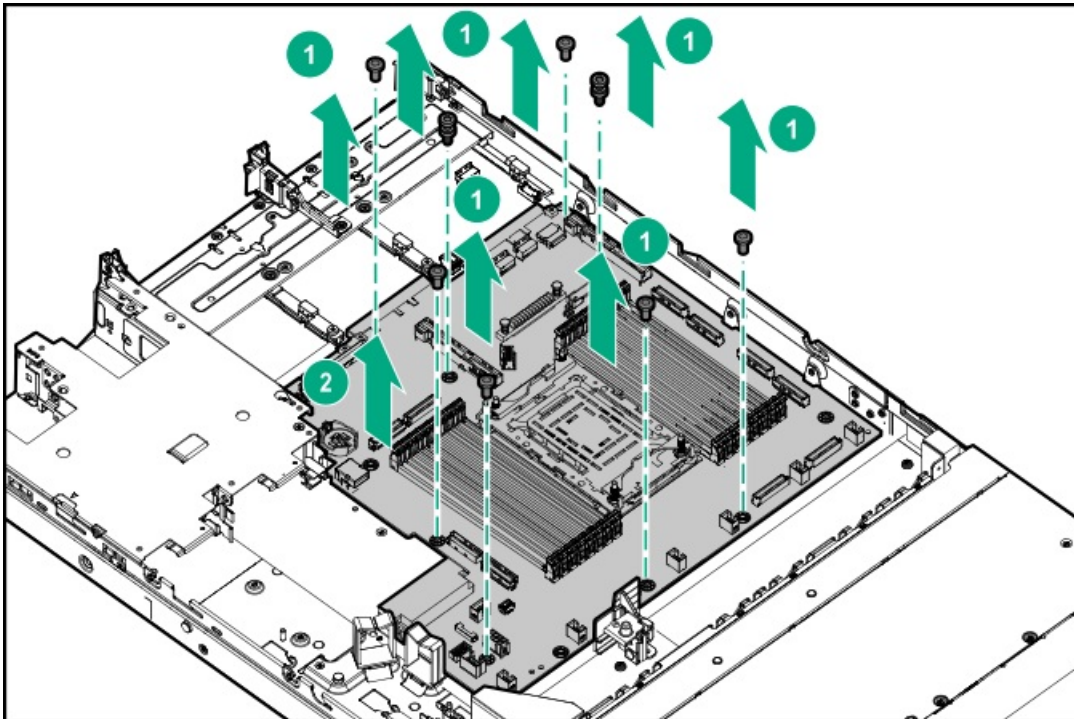

Installing the system board

Prerequisites



CAUTION

Be sure to have the BitLocker recovery key/password prior to replacing the system board. If you do not have the key/password, you will need to reinstall the OS.



CAUTION

Do not use One-button secure erase (OBSE). OBSE should only be used to decommission or repurpose a system. **This option erases all data. Be sure to disconnect any drives, SANs, NAS, or other shared/external storage devices that you do not want erased.**

Before you perform this procedure, make sure that you have the following items available:

- iLO login credentials from the customer—These are required to bind the existing DC-SCM with the new system board.



IMPORTANT

If you do not know the iLO login credentials or you cannot log in to iLO, [reset your iLO login credentials](#).

- T-10 Torx screwdriver
- T-15 Torx screwdriver
- T-30 Torx screwdriver
- Hex screwdriver—This tool is required if the serial port cable is to be installed.
- Thermal grease

About this task



CAUTION

A discharge of static electricity from a finger or other conductor might damage system boards or other static-sensitive devices. To prevent damage, observe [antistatic precautions](#).

Procedure

1. Install the system board.

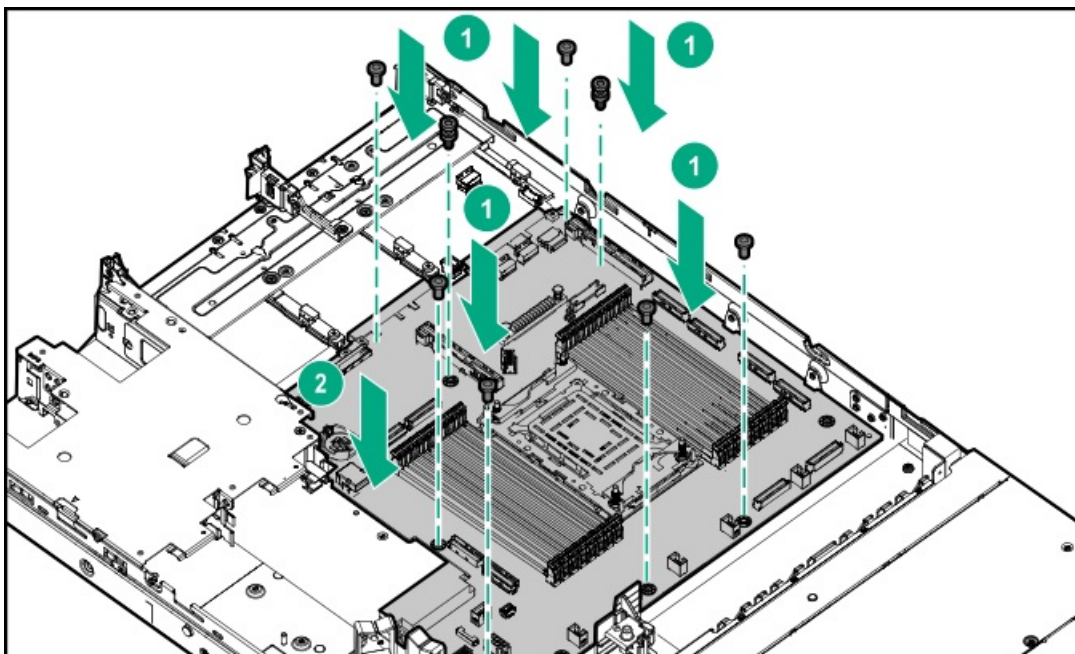



2. Connect the PDB to the system board, and then install the screws.

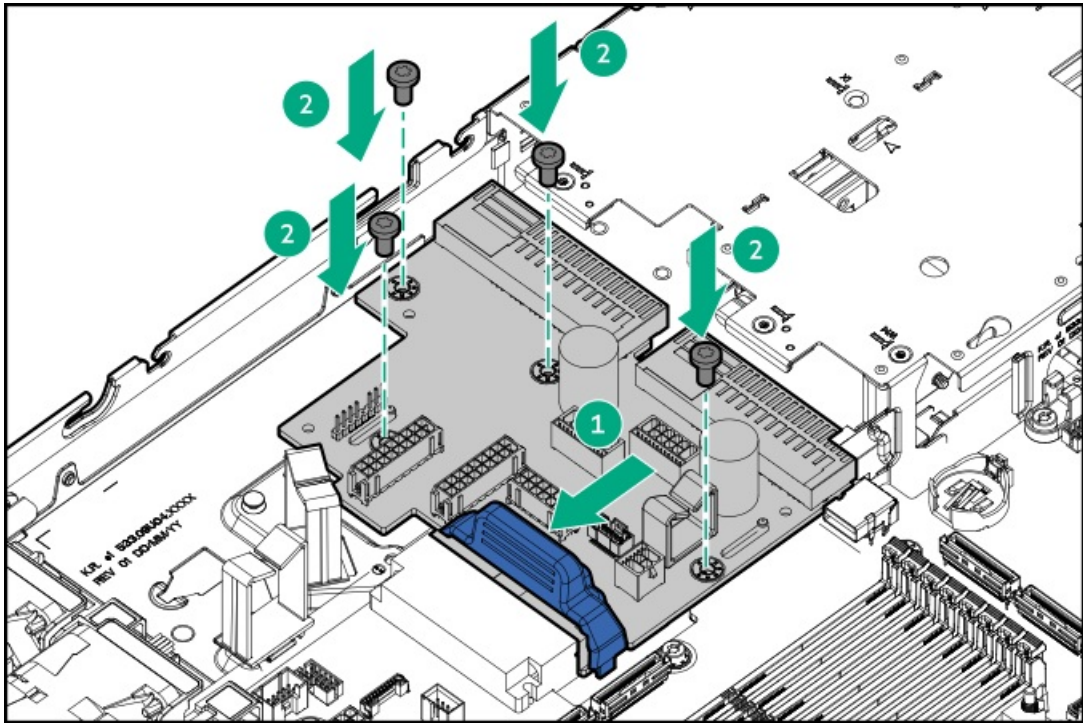

3. Slide the spools of the energy pack bracket to engage with the chassis, and then install the screw.

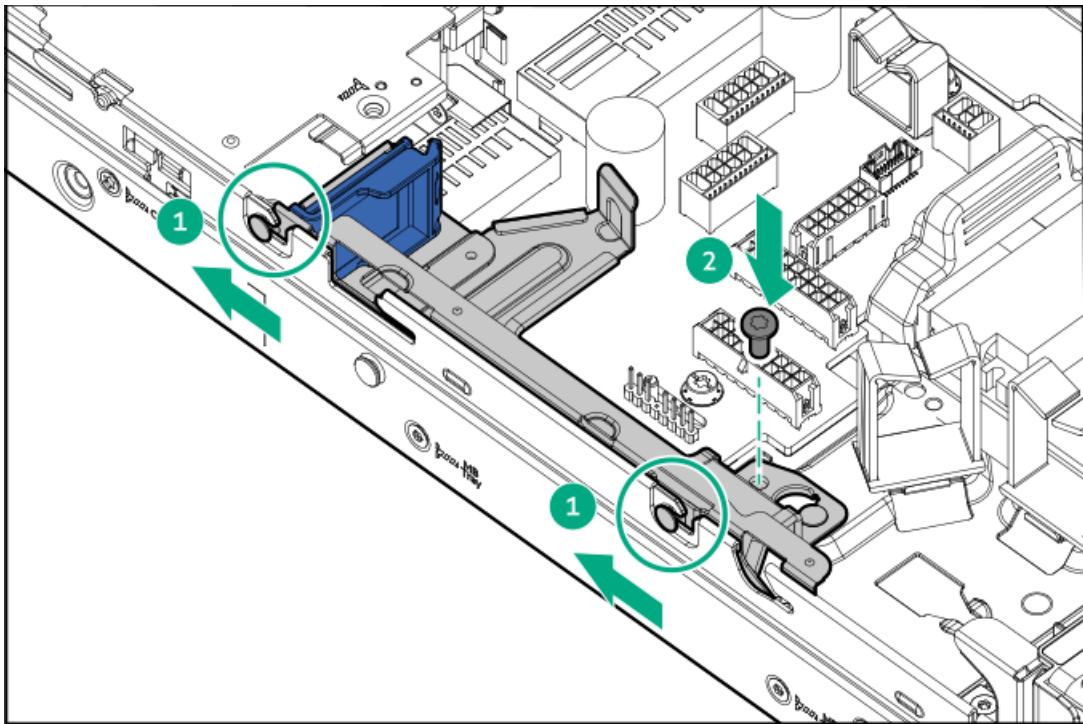

4. Install the processor-heatsink module:



CAUTION

To prevent mechanical damage or depositing oil on your hands or other contaminants to the heatsink contact surface, hold the heatsink only by the edge of its base plate. Do not touch the heatsink fins.





CAUTION

To prevent thermal failure or component damage, do not move the heatsink once the bottom of its base plate touches the top of the processor. Excessive heatsink movement can cause the thermal grease to smear and become uneven. Voids in the compound can adversely impact the transfer of heat away from the processor.

- a. When using a torque wrench to tighten the heatsink screws, set it to 0.9 N-m (8 in-lb) of torque .
- b. Note the **Front of server** text on the heatsink label to correctly orient the processor-heatsink module over the bolster plate.
- c. Carefully lower the processor-heatsink module straight down onto the bolster plate guide posts.

The posts are keyed so that the module can only be installed one way. Make sure that the module is properly seated on the bolster plate before securing the screws.

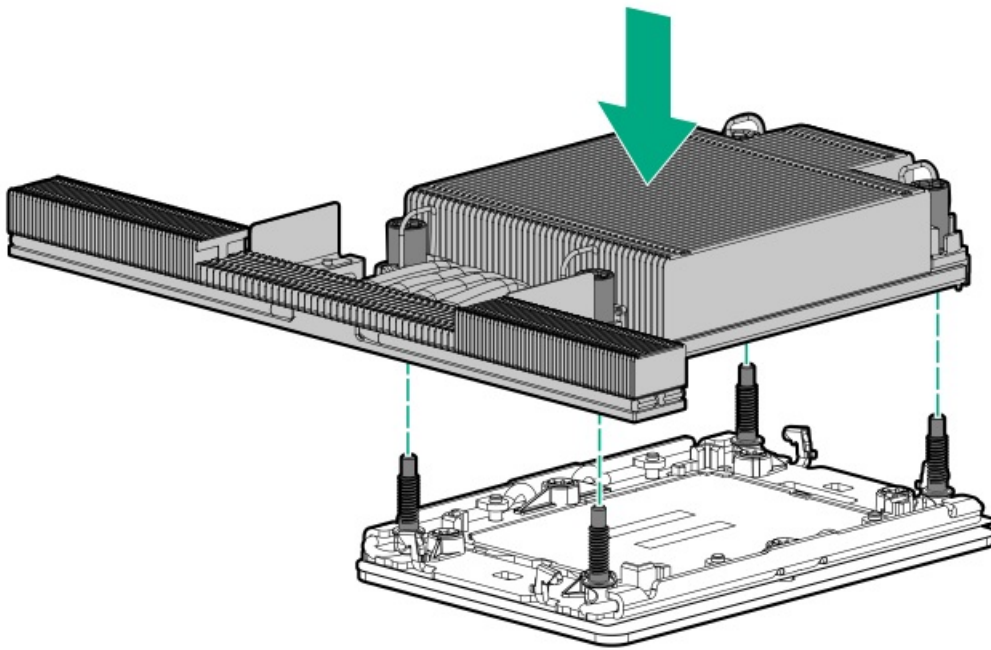

- d. Set the anti-tilt wires to the locked position.

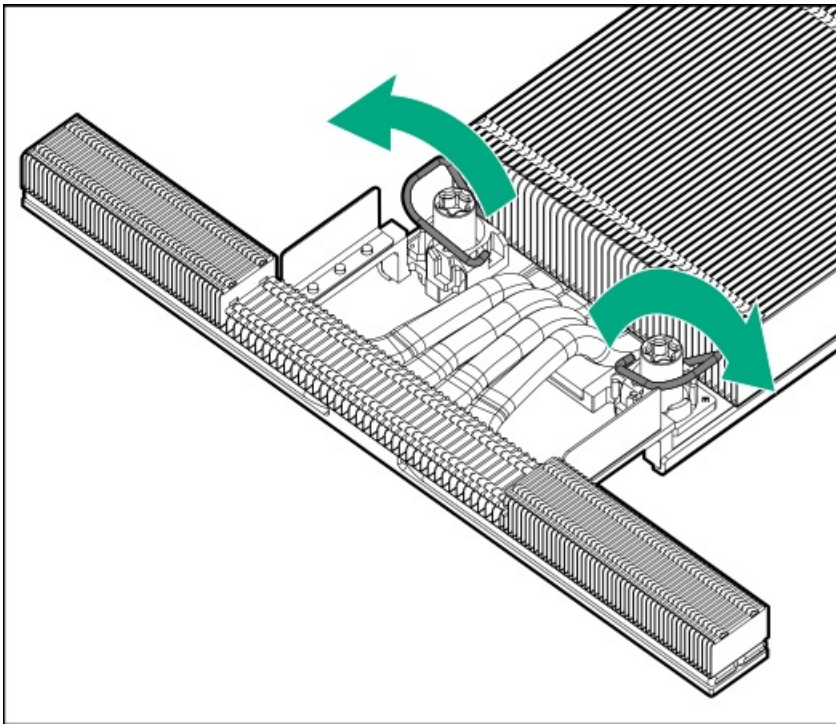

- e. Use a T-30 Torx screwdriver to tighten one pair of diagonally opposite heatsink screws, and then tighten the other pair of heatsink screws.

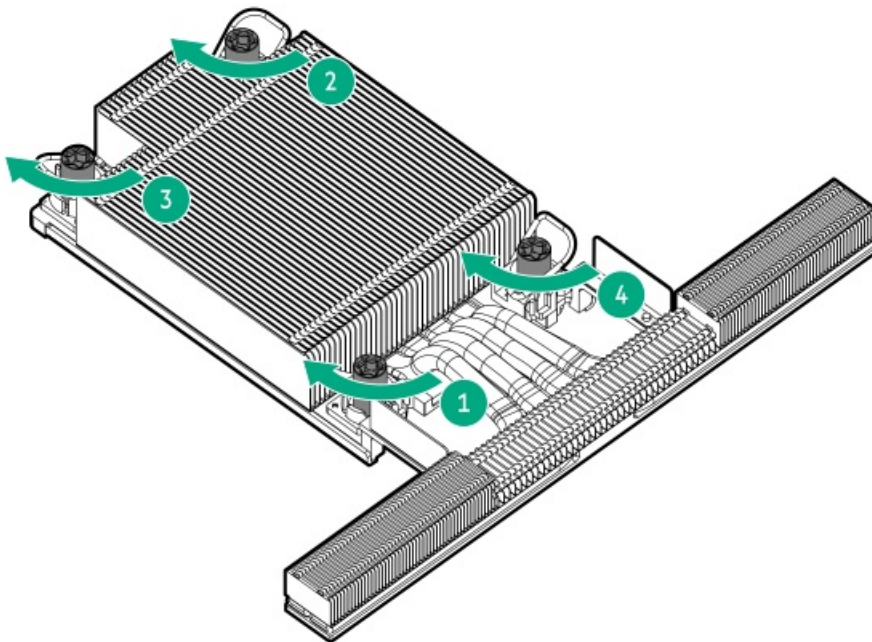

- 5. Install the DIMM guards.

- Left:



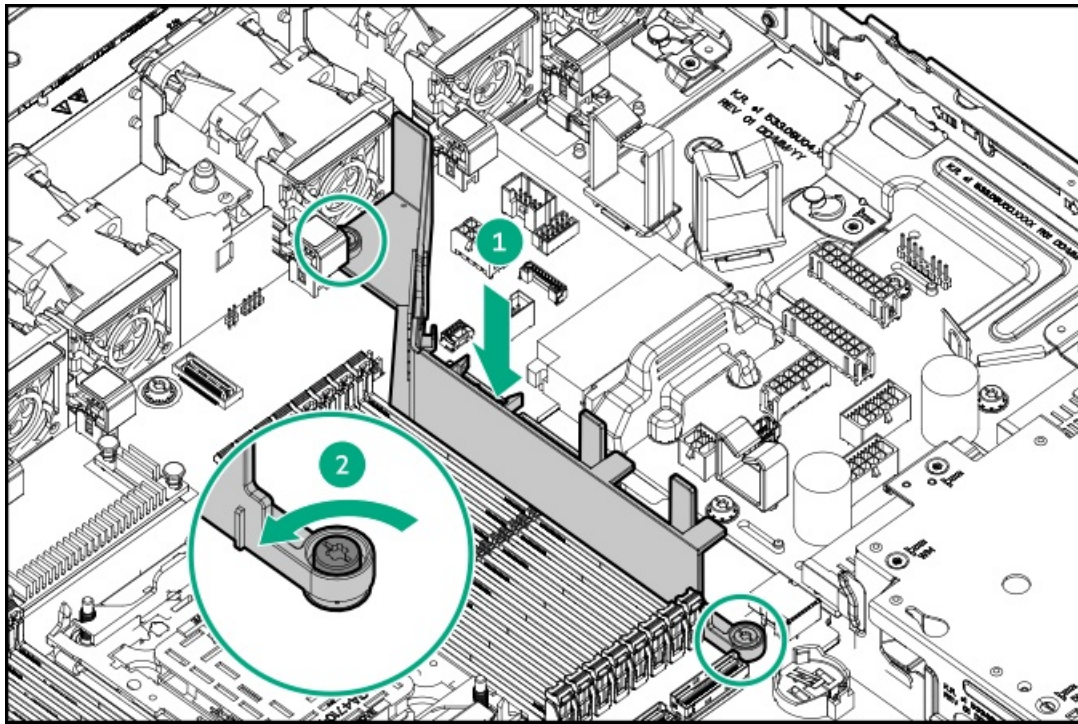

• Right:

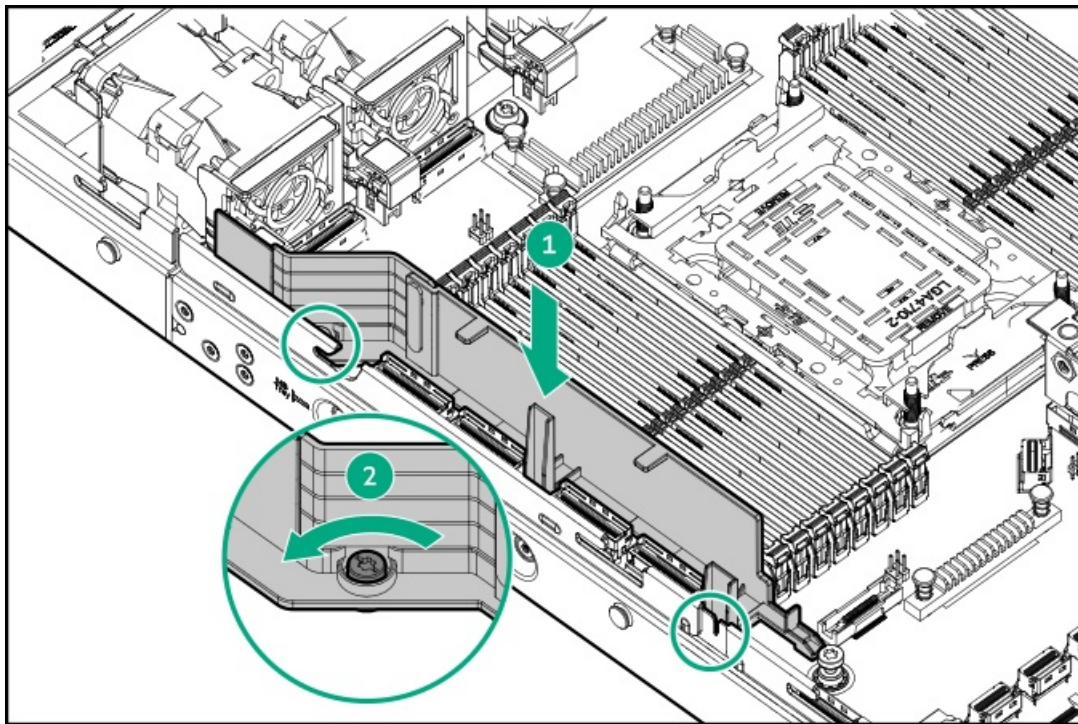

6. Install the ix port cable clamp.



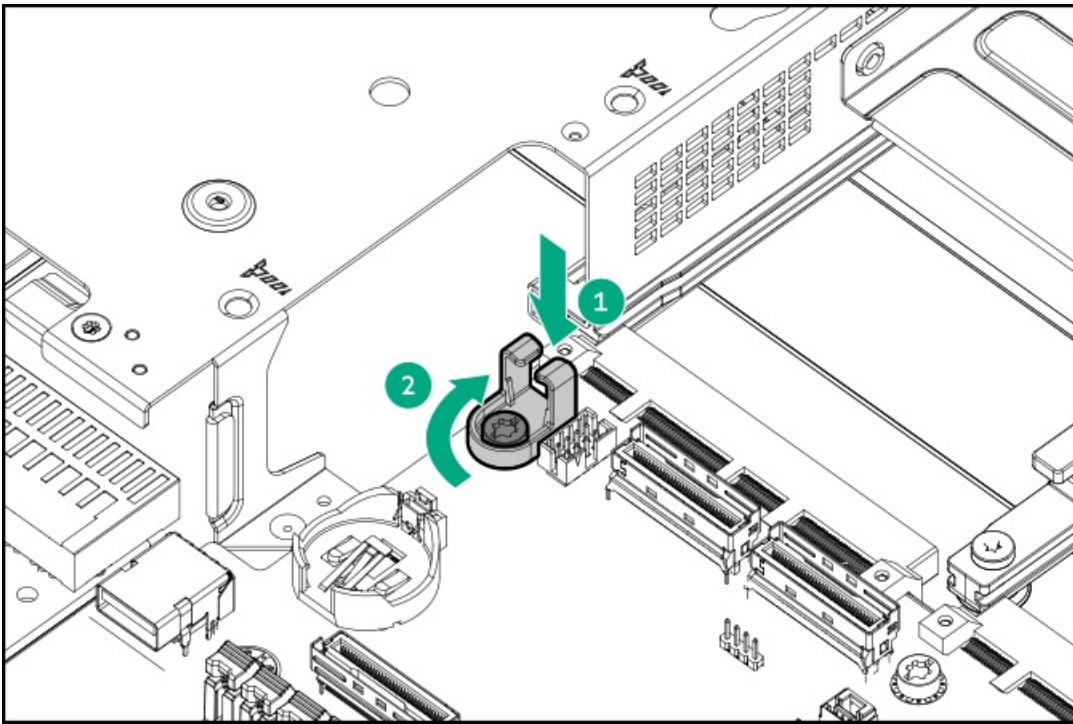

7. Install the DC-SCM:

- a. Rotate the locking pin to the open (vertical) position.
- b. Slide the module into the slot until it clicks into place. Make sure that the module is seated firmly in the slot.
- c. Rotate the locking pin to the close (horizontal) position.

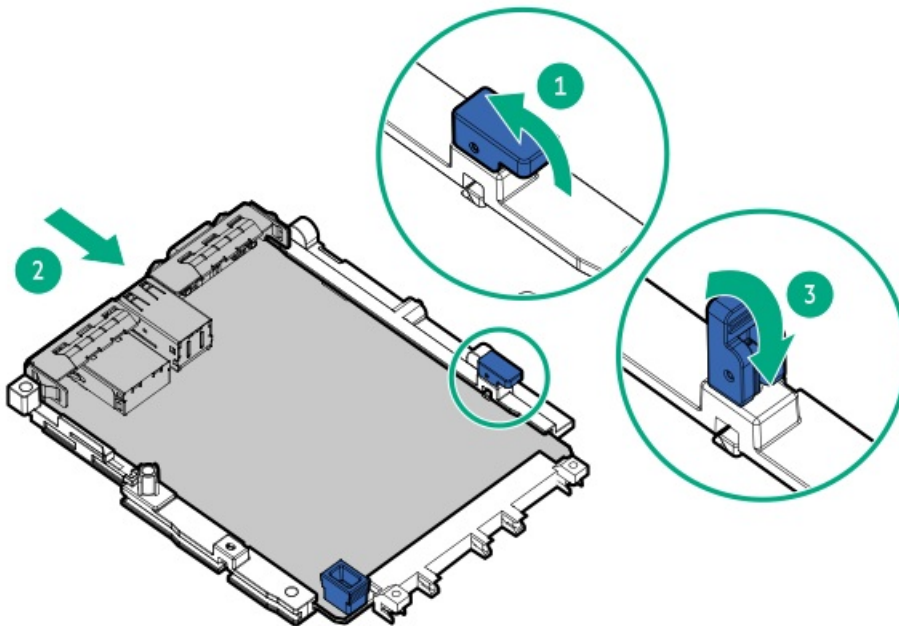

8. Install all the components removed from the system board.
9. Install the access panel.
10. Install the server into the rack.
11. Connect all peripheral cables to the server.

12. Connect each power cord to the server.
13. Connect each power cord to the power source.
14. [Power up the server.](#)
15. Bind the DC-SCM with the system board using one of the following tools:
 - [iLO web interface](#)
 - [iLO RESTful API](#)
 - [UEFI System Utilities](#)
16. Make sure all firmware, including option cards and embedded devices, is updated to the same versions to ensure that the latest drivers are being used.
17. [Re-enter the server serial number and product ID.](#)
18. See the applicable OS documentation for procedures and recommendations on restoring the OS and accessing drive data.



CAUTION

(For Microsoft Windows only) After replacing the system board, we recommend using BitLocker Recovery to restore the OS and access drive data. The recovery key/password previously generated during the initial server installation and BitLocker setup is required to enter Recovery Mode.

For more information about BitLocker Recovery, see the [Microsoft website](#).

Results

The replacement procedure is complete.

Binding the DC-SCM with the HPM

Subtopics

- [Binding the DC-SCM with the HPM using the iLO web interface](#)
- [Binding the DC-SCM with the HPM using the UEFI System Utilities](#)
- [Resetting the iLO login credentials](#)

Binding the DC-SCM with the HPM using the iLO web interface

Prerequisites

- Administrator with Recovery Set privilege.
- The server is powered off.

Procedure

1. Log in to iLO and click Settings in the navigation tree, and then click Troubleshoot.
2. Click System Diagnostics > Bind DC-SCM with HPM.
3. Click Automatically perform AUX Power cycle immediately after bind is complete to perform AUX power cycle once the bind is complete.
4. Click Yes, proceed to confirm the request.

5. (Optional) To view the latest changes, click **AUX Cycle**.

A confirmation dialog box appears.

6. Click **Yes, proceed**.

iLO initiates a reset. After the reset, log in to iLO again and access the Integrated Management Log to check if the binding is successful.

If the binding fails, repeat this procedure. If the binding fails, download the AHS log and contact [HPE Support](#).

Binding the DC-SCM with the HPM using the UEFI System Utilities

Prerequisites

Administrator has the Recovery Set privilege.

Procedure

1. From the System Utilities screen, select **System Configuration > BIOS/Platform Configuration (RBSU) > Advanced Options > HPM Rebinding Request**.
2. Click **Ok** on the warning that appears.
3. Select **Yes** to start the process.
4. Input iLO Username, iLO Password with recovery set.
 - If the credentials are valid with recovery set, the final confirmation appears asking **Do you really want to request rebinding HPM?** Click **Ok**.
 - If the credentials are not with recovery set or are incorrect, an error **Wrong iLO Credential** appears. Verify your credentials and enter again.
5. Save your setting.

Resetting the iLO login credentials

Prerequisites

- The server has a UID button
- Physical access to the server
- An external monitor is connected

Procedure

1. **Power down the server.**
2. Remove all power:
 - a. Disconnect each power cord from the power source.
 - b. Disconnect each power cord from the server.
3. Change the **system maintenance switch position 1** to the **ON** position.

A plastic ball-point pen can be used to flip the system maintenance switch to the **ON** position.
4. Connect each power cord to the server.

5. Connect each power cord to the power source.
6. Power up the server.
7. Press the server UID button.



CAUTION

Press and release the UID button. Holding it down at any time for more than 5 seconds initiates a graceful iLO reboot or a hardware iLO reboot. Data loss might occur during a hardware iLO reboot.

The Server Health Summary screen appears on the external monitor. Record the NODEIDNONCE.

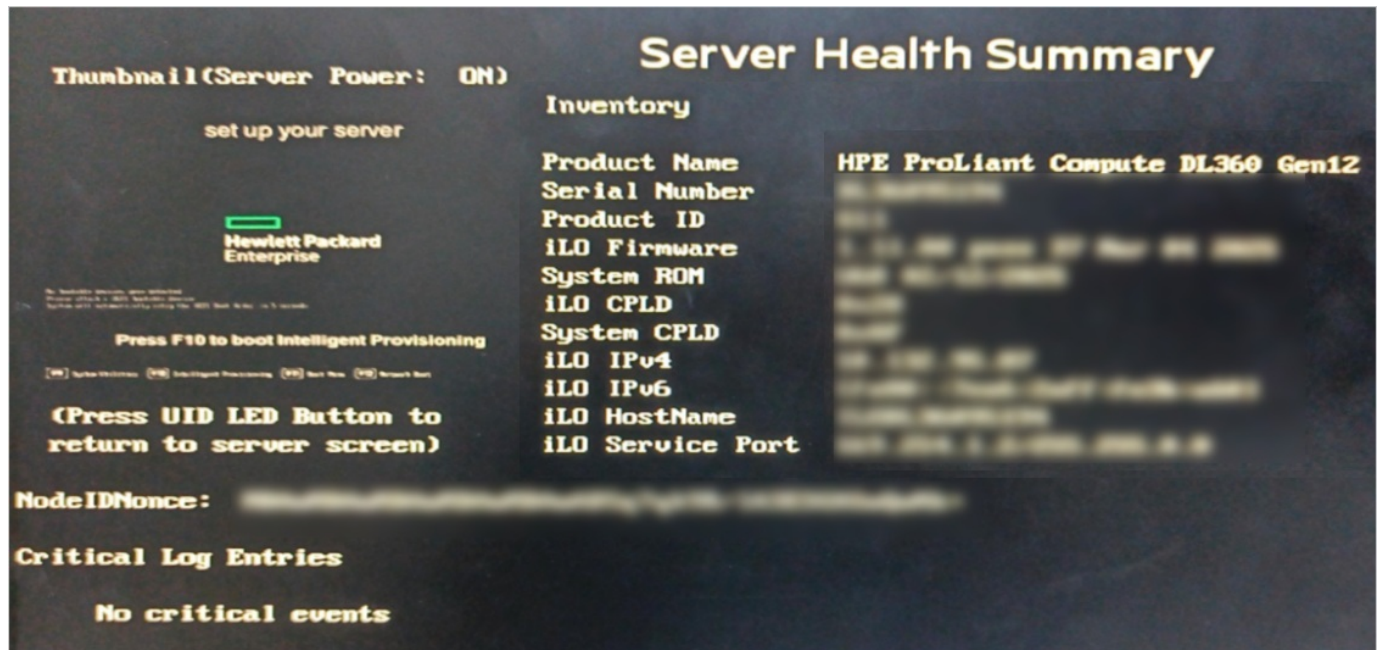

8. Send an email with the NODEIDNONCE record to an HPE support representative.

For more information, go to the [HPE Support Center](#).

Hewlett Packard Enterprise recommends adding the following information in the email:

- Server location
- Customer address with a disclaimer to proceed with the factory reset of the server while performing password recovery
- nodeBatch.csv file with information about every server that needs to be factory reset

The format of the file must be `NodeID,email,Customer: [location]`

For example, `fevxba9876643260fedbbd9876545210, abc@test.com, Customer: Abc Canada`

The Signed NodeID is sent to your registered email. It might take a day or two to receive the Signed NodeID.

9. Use the Signed NodeID received on the email to reset the iLO password using one of the following tools:
 - [iLO web interface](#)
 - [iLO RESTful API](#)

Subtopics

[Recovering the iLO default password using the iLO web interface](#)

[Recovering the iLO login credentials using iLO RESTful API](#)

Recovering the iLO default password using the iLO web interface

Prerequisites

Make sure that the [system maintenance switch 1](#) is set to the **ON** position.

Procedure

1. In the iLO login screen, click **Recover Password**.

Recover Password window appears.

2. Enter the Signed NodeID.

The Signed NodeID cannot be used multiple times. A login delay occurs after multiple failed attempts.

For more information on generating the Signed NodeID, see the iLO troubleshooting guide (<https://www.hpe.com/support/hpeilodocs-quicklinks>).

3. Enter the New Password.

The password must be 8-15 characters. If Password Complexity is enabled, the password must have one uppercase letter, one lowercase letter, and one digit.

Upon successful validation, iLO resets and the new password is set. After the reset, log in to iLO with the default user name (Administrator) and the new password.

4. Click **Cancel**.
5. Click **X** to close the **Recover Password** window.
6. Log in to iLO with the default user name (Administrator) and the new password.
7. Change the position of switch 1 to the **OFF** position.

Recovering the iLO login credentials using iLO RESTful API

Prerequisites

Make sure that the [system maintenance switch 1](#) is set to the **ON** position.

- The server has a UID button
- Physical access to the server
- An external monitor is connected

Procedure

1. Use the PATCH command `https://<ilo-ip>/redfish/v1/AccountService/Accounts/65536`.
2. Provide the user name as `HpeNodeRecover` and password Signed NodeID.
3. Specify the Payload in the following JSON format:

```
{
  "Password": "new_password"
}
```

The password must have 8-15 characters. If Password Complexity is enabled, the password must have one uppercase letter, one lowercase letter, and one digit.

4. Log in to iLO with the default user name (Administrator) and the new password.

5. Change the position of switch 1 to the **OFF** position.

Re-entering the server serial number and product ID

About this task

After replacing the system board, re-enter the system serial number and product ID.

Procedure

1. Access the UEFI System Utilities. During POST, press **F9**.
2. From the System Utilities screen, select **System Configuration > BIOS/Platform Configuration (RBSU) > Advanced Options > Advanced Service Options**.
3. Select **Serial Number**, and then press **Enter**.

The following warning appears:

```
The serial number is modified by qualified service personnel and must
match the serial number located on the chassis.
```

4. Click **OK**.
5. Type the serial number, and then press **Enter**.
6. Select **Product ID**, and then press **Enter**.

The following warning appears:

```
Product ID is modified only by qualified service personnel. This value
must match the product ID located on the chassis.
```

7. Type the product ID, and then press **Enter**.
8. To confirm and save the settings, press **F12**.

The server automatically reboots.

Results

The installation procedure is complete.

Component identification

This chapter describes the external and internal server features and components.

Subtopics

[Front panel components](#)

[Front panel LEDs and buttons](#)

[Rear panel components](#)

[Rear panel LEDs](#)

[System board and power distribution board components](#)

[Component touchpoints](#)

[System Insight Display LEDs](#)

[System Insight Display combined LED descriptions](#)

- [Drive bay numbering](#)
- [HPE Basic Drive LED definitions](#)
- [EDSFF SSD LED definitions](#)
- [GPU riser slot numbering](#)
- [Drive backplane naming](#)
- [Fan numbering](#)
- [Heatsink and processor socket components](#)
- [Closed-loop liquid cooling components](#)
- [Liquid cooling guidelines](#)
- [Fan and heatsink requirements](#)
- [Datacenter Secure Control Module components](#)
- [OCP NIC 3.0 slot numbering](#)
- [HPE NS204i-u Boot Device V2 components](#)
- [HPE NS204i-u Boot Device V2 LED definitions](#)
- [Riser board components](#)

Front panel components

8 + 2 SFF drive configuration

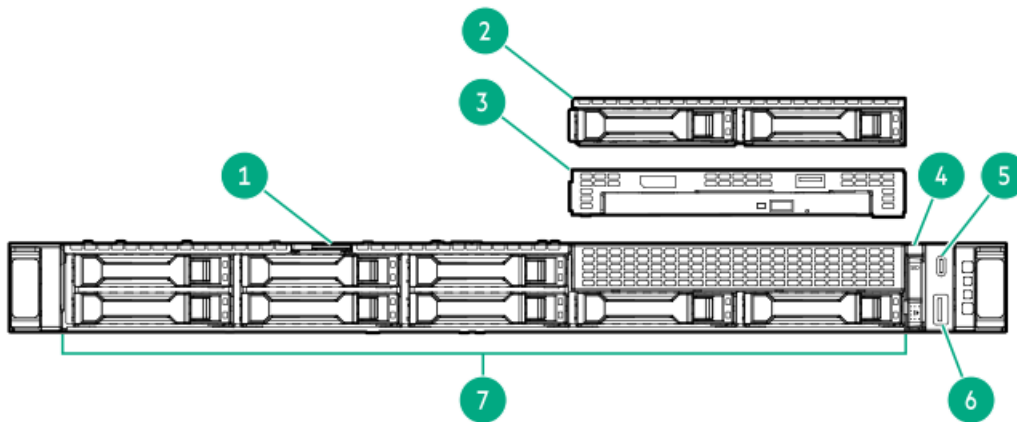

Item	Description
1	Serial number/iLO information pull tab ¹
2	2 SFF side-by-side drive cage assembly (optional) ²
3	Optical drive cage assembly (optional) ³
4	System Insight Display (optional)
5	iLO Service Port
6	USB 3.2 Gen 1 port
7	8 SFF drives

¹ The serial number/ iLO information pull tab is double-sided. One side shows the server serial number and the customer asset tag label. The other side shows the default iLO account information.

² Depending on the drive backplane installed, the server supports SATA, SAS, U.2 NVMe, and U.3 NVMe drives.

³ This assembly includes:

- One DisplayPort 1.1a
- One USB 2.0
- One optical drive bay

4 LFF drive configuration

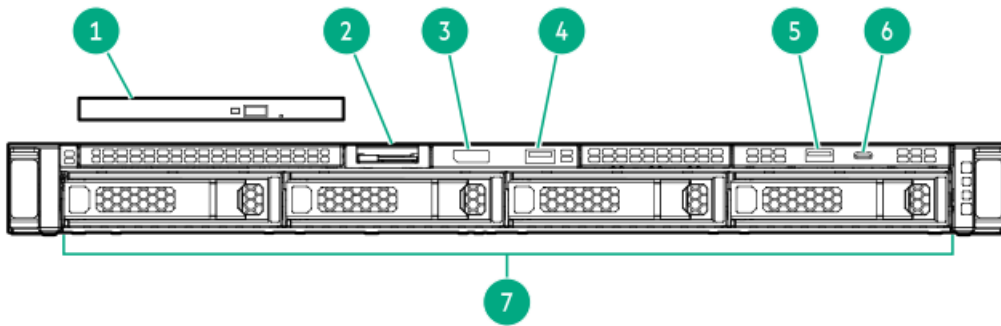

Item	Description
1	Optical drive cage (optional)
2	Serial number/iLO information pull tab
3	DisplayPort 1.1a (optional)
4	USB 2.0 port (optional)
5	USB 3.2 Gen 1 port
6	iLO Service Port
7	4 LFF drives

20 E3.S drive configuration

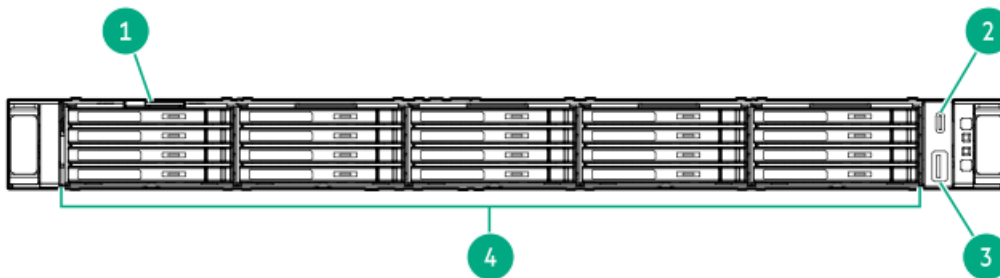

Item	Description
1	Serial number/iLO information pull tab
2	iLO Service Port
3	USB 3.2 Gen 1 port
4	20 E3.S drives

10 SFF or 20 E3.S mixed drive configuration with options

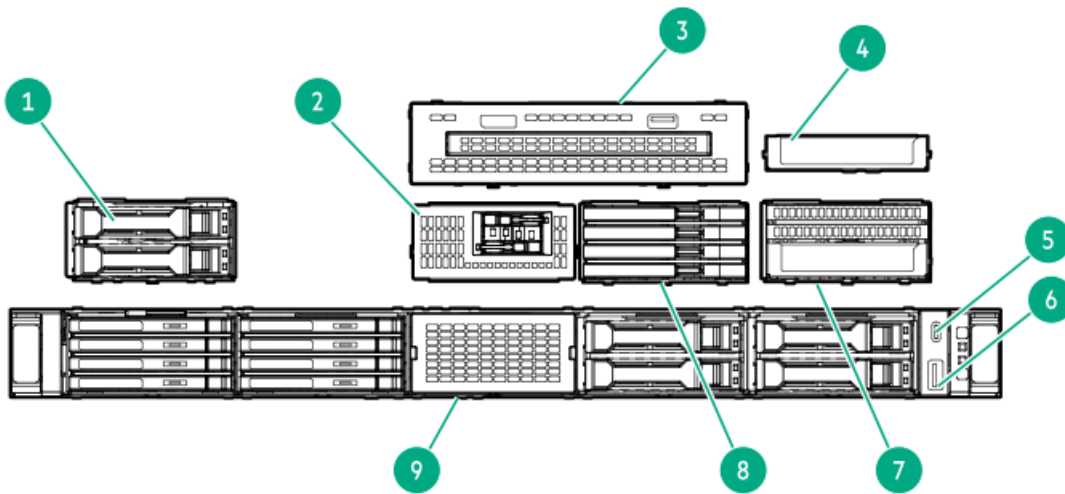

Item	Description
1	2 SFF drives (optional)
2	NS204i-u boot device (optional) ¹
3	Universal media bay (optional) ²
4	Front OCP (optional) ³
5	iLO Service Port
6	USB 3.2 Gen 1 port
7	Front OCP cage ⁴
8	4 E3.S drives (optional)
9	Front OCP blank

- ¹ This option is installed in box 3.
² This option is installed in box 4 and 5.
³ This option is installed in box 3 bay 1 or bay 3.
⁴ This option is installed in box 3.

4 SFF drive configuration with a GPU riser cage

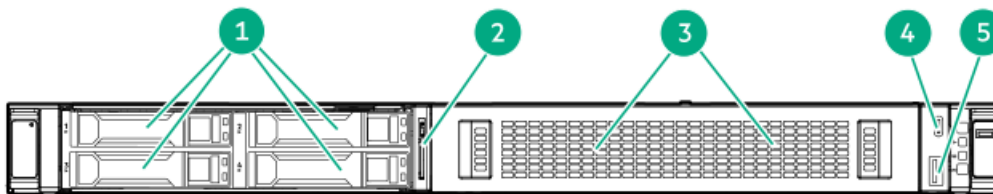

Item	Description
1	4 SFF drives
2	Serial number/iLO information pull tab
3	GPU riser cage
4	iLO Service Port
5	USB 3.2 Gen 1 port

8 E3.S drive configuration with a GPU riser cage

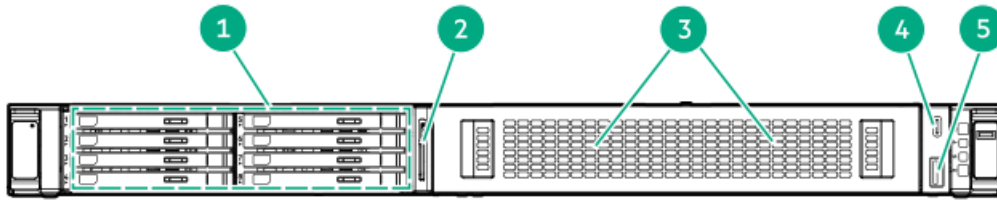

Item	Description
1	8 E3.S drives
2	Serial number/iLO information pull tab
3	GPU riser cage
4	iLO Service Port
5	USB 3.2 Gen 1 port

Front panel LEDs and buttons

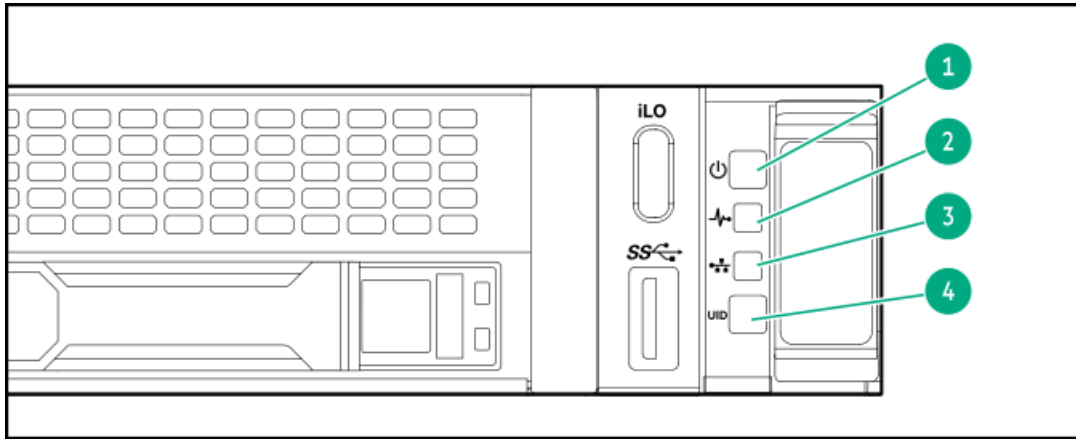

Item	Description	Status	Definition
1	Power On/Standby button and system power LED ¹	Solid green	System on
		Flashing green	Performing power-on sequence
		Solid amber	System in standby
		Off	No power present ²
2	Health LED ³	Solid green	Normal
		Flashing green	iLO is rebooting
		Flashing amber	System degraded ³
		Flashing red	System critical ³
3	NIC status LED ¹	Solid green	Linked to network
		Flashing green	Network active
		Off	No network activity
4	UID button/LED ¹	Solid blue	Activated
		Flashing blue	<ul style="list-style-type: none"> 1 flash per second—Remote management or firmware upgrade in progress 4 flashes per second—iLO manual reboot sequence initiated 8 flashes per second—iLO manual reboot sequence in progress
		Off	Deactivated

¹ When all LEDs flash simultaneously, a power fault has occurred. For more information, see [Front panel LED power fault codes](#).
² Facility power is not present, power cord is not attached, no power supplies are installed, or power supply failure has occurred.
³ If the health LED indicates a degraded or critical state, [review the system Integrated Management Log \(IML\)](#) or use [HPE iLO](#) to review the system health status.

Rear panel components

Rear panel with 60 mm PSU

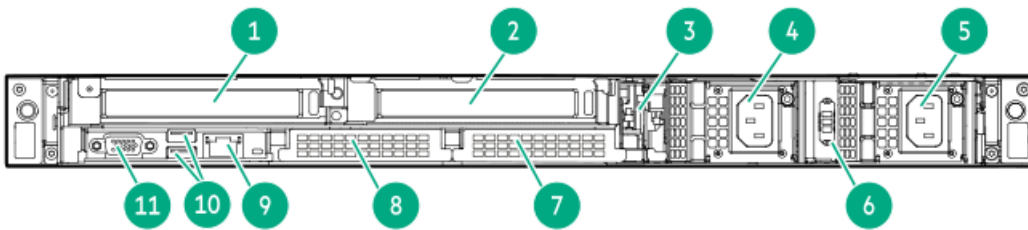

Item	Description
1	Slot 1 PCIe5 x16 (optional)
2	Slot 2 PCIe5 x16 (optional)
3	NS204i-u boot device (optional)
4	M-CRPS 2 (optional)
5	M-CRPS 1
6	ix port (optional) ¹
7	Slot 21 OCP B PCIe5 x16 (optional)
8	Slot 20 OCP A PCIe5 x16
9	iLO dedicated network port ²
10	USB 3.2 Gen 1 ports ²
11	VGA port ³

¹ The ix port connects to an external serial port dongle.

² These components are on the DC-SCM option.

³ Connect a display device to the VGA port. Use of any kind of adapter, converter cable, or dongle might lead to decreased display quality or lag over the connection.

Rear panel with 73.5 mm PSU

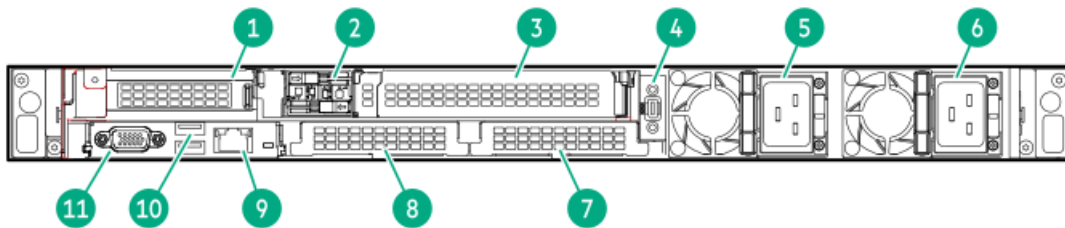

Item	Description
1	Slot 1 PCIe5 x16 (optional)
2	NS204i-u boot device (optional)
3	Slot 2 PCIe5 x16 (optional)
4	ix port (optional)
5	M-CRPS 2 (optional)
6	M-CRPS 1
7	Slot 21 OCP B PCIe5 x16 (optional)
8	Slot 20 OCP A PCIe5 x16
9	iLO dedicated network port
10	USB 3.2 Gen 1 ports
11	VGA port

Rear panel LEDs

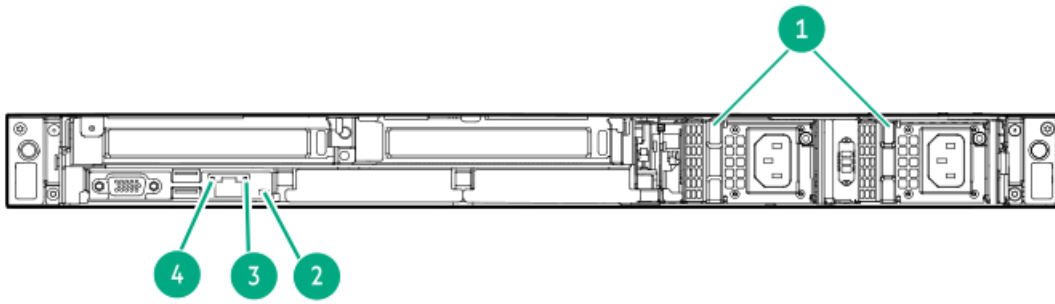

Item	LED	Status	Definition
1	Power supply	Solid green	The power supply is operating normally.
		Flashing green	<ul style="list-style-type: none"> 1 flash per sec—Power supply is in standby mode 2 flashes per sec—Power supply firmware is updating
		Solid amber	One or more of the following conditions exists: <ul style="list-style-type: none"> Power supply failure Power supply error
		Off	One or more of the following conditions exists: <ul style="list-style-type: none"> Power is unavailable The power cord is disconnected.
2	UID	Solid blue	Activated
		Flashing blue	<ul style="list-style-type: none"> 1 flash per sec—Remote management or firmware upgrade in progress 4 flashes per sec—iLO manual reboot sequence initiated 8 flashes per sec—iLO manual reboot sequence in progress
		Off	Deactivated
3	iLO status	Solid green	Linked to network
		Flashing green	Network active
		Off	No network activity
4	iLO link	Solid green	Network link
		Off	No network link

System board and power distribution board components

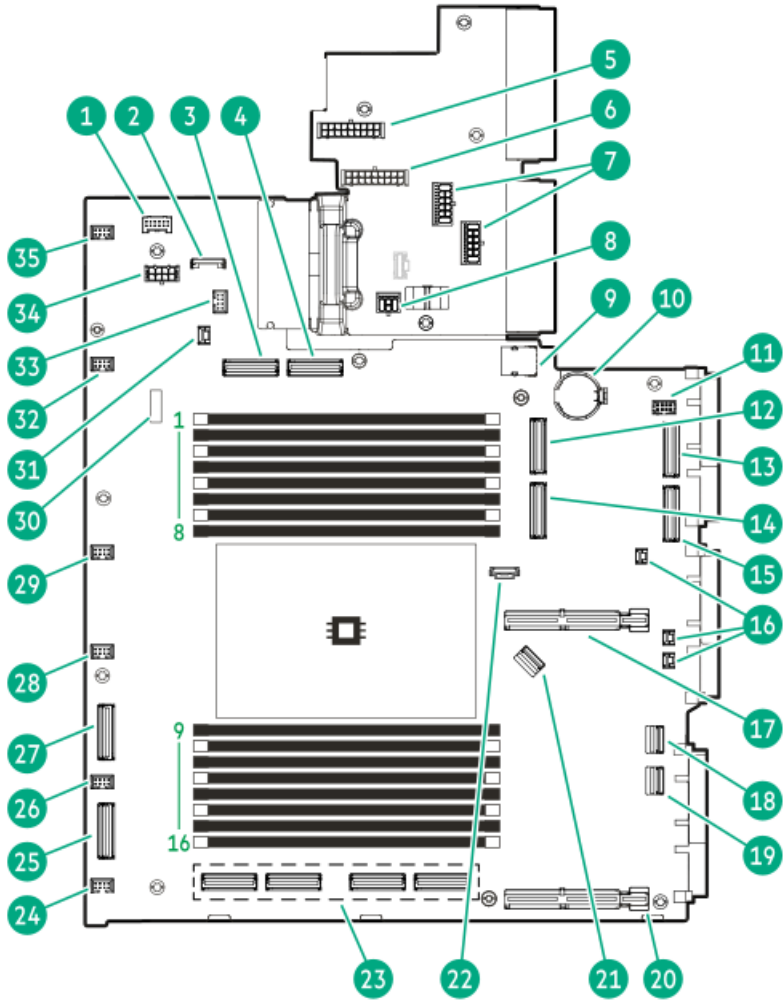

Item	Description
1	Energy pack connector
2	SID connector
3	M-XIO port 6
4	M-XIO port 4
5	Box 1, 2 drive backplane power connector
6	Box 3, 4 drive backplane power connector
7	2 x 6 M-PIC power connectors
8	2 x 3 M-PIC power connector
9	USB 3.2 Gen1 port
10	System battery
11	NS204i-u power connector
12	M-XIO port 17
13	MCIO OCP B-1 input port
14	M-XIO port 13
15	MCIO OCP B-2 input port
16	Storage controller backup power connector
17	Secondary riser connector
18	Front I/O connector
19	USB 2.0 DisplayPort cable connector
20	Primary riser connector
21	NS204i-u signal connector
22	CLC connector
23	M-XIO ports ¹
24	Fan connector 7
25	M-XIO port 0
26	Fan connector 6
27	M-XIO port 2
28	Fan connector 5
29	Fan connector 4
30	<u>System maintenance switch</u>
31	Chassis intrusion detection switch connector
32	Fan connector 3
33	Fan connector 1
34	Box 5 drive backplane power connector
35	Fan connector 2

¹ These M-XIO ports are numbered 7, 5, 1, and 3 from left to right.

Subtopics

[System maintenance switch descriptions](#)

[DIMM slot numbering](#)

[DIMM label identification](#)

System maintenance switch descriptions

Position	Default	Function
S1 ¹	Off	<ul style="list-style-type: none">Off—iLO 7 security is enabled.On—iLO 7 security is disabled.
S2	Off	Reserved
S3	Off	Reserved
S4	Off	Reserved
S5 ¹	Off	<ul style="list-style-type: none">Off—Power-on password is enabled.On—Power-on password is disabled.
S6 ^{1, 2, 3}	Off	<ul style="list-style-type: none">Off—No functionOn—Restore default manufacturing settings
S7	Off	Reserved
S8	Off	Reserved
S9	Off	Reserved
S10	Off	Reserved
S11	Off	Reserved
S12	Off	Reserved

- ¹ To access the redundant ROM, set S1, S5, and S6 to On.
- ² When the system maintenance switch position 6 is set to the On position, the system is prepared to restore all configuration settings to their manufacturing defaults.
- ³ When the system maintenance switch position 6 is set to the On position and Secure Boot is enabled, some configurations cannot be restored. For more information, see [Configuring the server](#).

DIMM slot numbering

The arrow points to the front of the server.

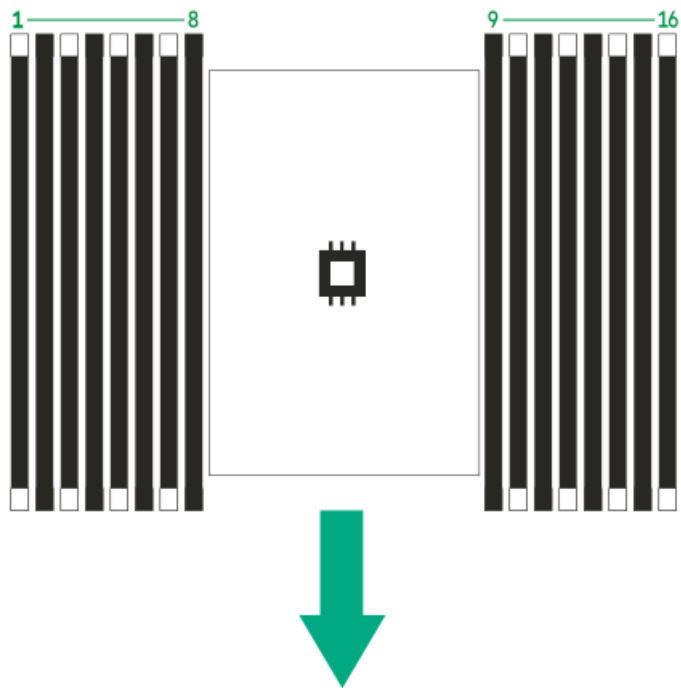

DIMM label identification

To determine DIMM characteristics, see the label attached to the DIMM. The information in this section helps you to use the label to locate specific information about the DIMM.

For more information about product features, specifications, options, configurations, and compatibility, see the [HPE DDR5 SmartMemory QuickSpecs](https://www.hpe.com/docs/server-memory):

<https://www.hpe.com/docs/server-memory>

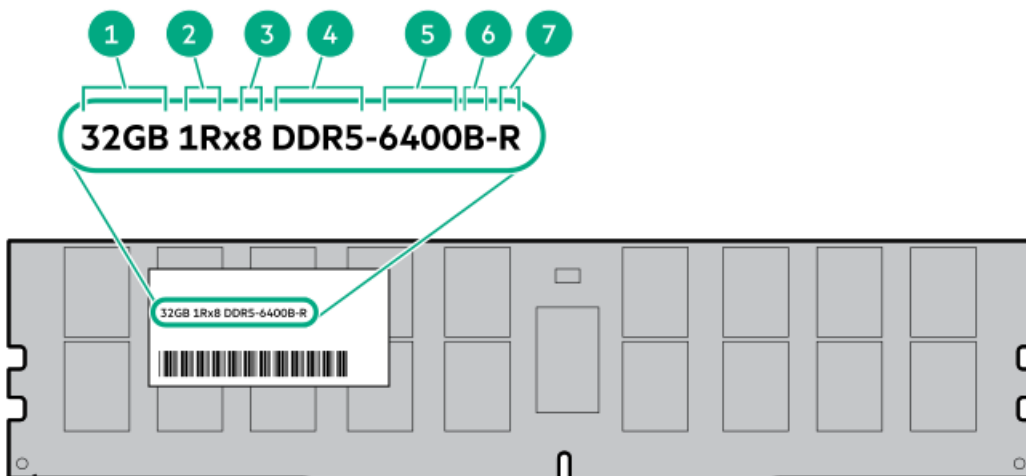

Item	Description	Example
1	Capacity*	16 GB 32 GB 64 GB 96 GB 128 GB 256 GB
2	Rank	1R—Single rank 2R—Dual rank 4R—Quad rank
3	Data width on DRAM	x4—4-bit x8—8-bit
4	Memory generation	PC5—DDR5
5	Maximum memory speed*	6400 MT/s
6	CAS latency	B—42-42-42
7	DIMM type	R—RDIMM (registered)

* The maximum memory speed and capacity is a function of the memory type, memory configuration, and processor model.

Component touchpoints

Certain components are color-coded. These colors represent the recommended touch areas for a removal process and indicate whether components require a system shutdown before removal.

The following diagrams are examples only.

HPE hot-plug red

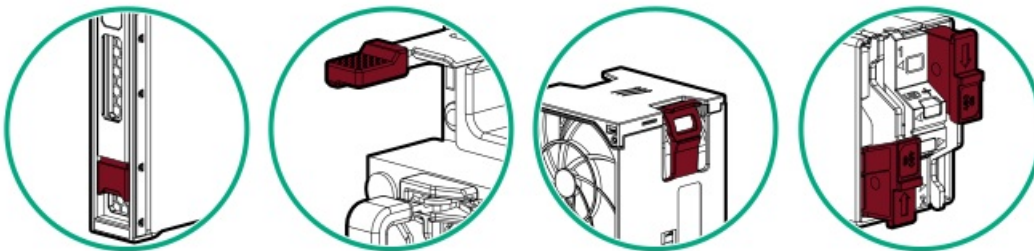

Hot-plug red indicates hot-pluggable components. These components can be removed and installed while the system is running, and doing so will not result in a system shutdown.

Component examples:

- Power supplies in a redundant power configuration
- Hot-plug fans
- Hot-plug drives
- M.2 SSDs in a hot-plug boot device

HPE touchpoint blue

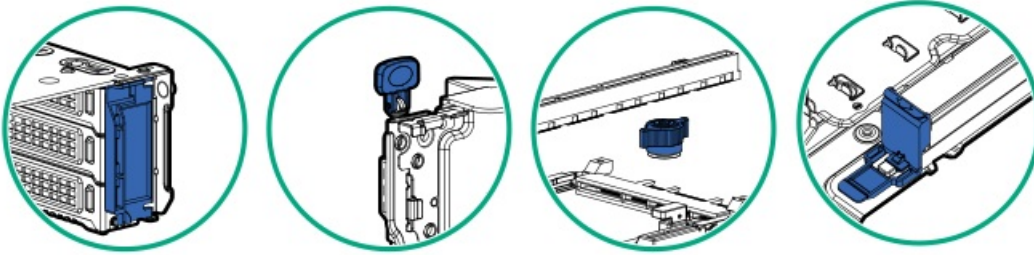

Touchpoint blue indicates cold-pluggable components. These components require a system shutdown. Failure to do so might result in system failure or data loss. Cold-pluggable components might also indicate touchpoints on non-electrical components.

Component examples:

- Storage devices
- Fan cages
- System boards
- Energy packs

System Insight Display LEDs

The System Insight Display (SID) LEDs represent components on the system board. The display enables component issue diagnosis even with the access panel installed.



IMPORTANT

If more than one DIMM slot LED is illuminated, further troubleshooting is required. Test each bank of DIMMs by removing all other DIMMs. Isolate the failed DIMM by replacing each DIMM in a bank with a known working DIMM.

For information about memory population rules, see the relevant memory technical paper in:

<https://www.hpe.com/docs/server-memory>

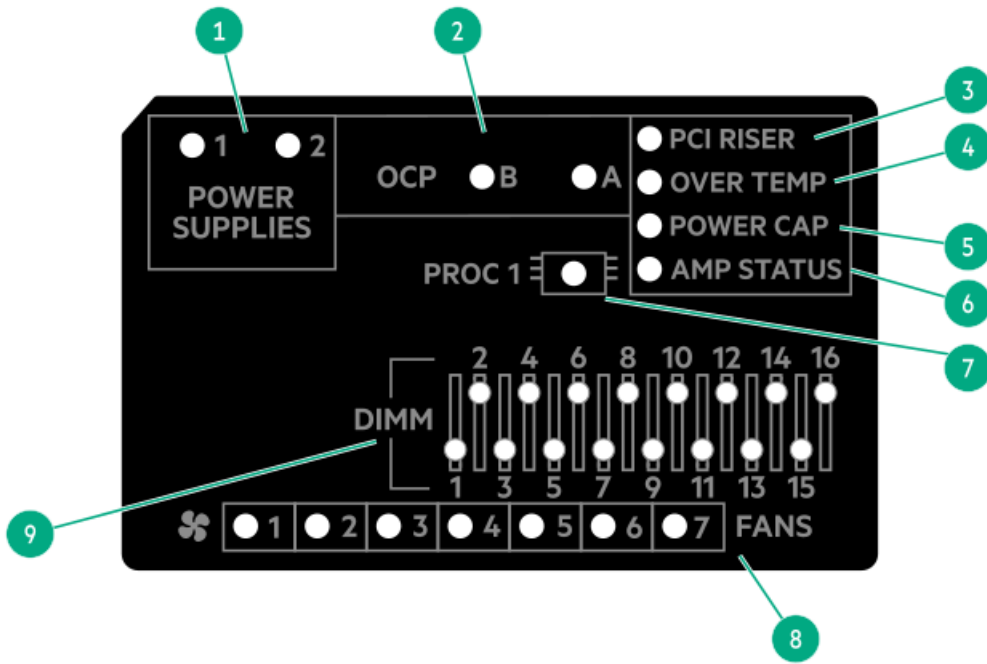

Item	LED	Status	Description
1	Power supply LEDs	Off	Normal
		Solid amber	One or more of the following conditions exists: <ul style="list-style-type: none"> Power subsystem degraded Power supply failure Input power lost
2	OCP LEDs	Solid green	Network link
		Flashing green	Network active
		Off	No network link
3	PCI riser LED	Off	Normal
		Solid amber	Incorrectly installed PCI riser cage
4	Over temp LED	Off	Normal
		Solid amber	High system temperature detected
5	Power cap LED	Solid green	Power cap applied
		Off	One or more of the following conditions exists: <ul style="list-style-type: none"> System is in standby No cap is set
6	AMP ¹	Solid green	AMP mode enabled
		Solid amber	Failover
		Flashing amber	Invalid configuration
		Off	AMP modes disabled
7	Processor LED	Off	Normal
		Solid amber	Failed processor
8	Fan LEDs	Off	Normal
		Solid amber	Failed fan or missing fan
9	DIMM LEDs	Off	Normal
		Solid amber	Failed DIMM or configuration issue

¹ To enable Advanced Memory Protection (AMP), see the UEFI user guide (<https://www.hpe.com/support/hpeuefisystemutilities-quicklinks>).

When the health LED on the front panel illuminates either amber or red, the server is experiencing a health event. For more information on the combination of these LEDs, see [System Insight Display combined LED descriptions](#).

System Insight Display combined LED descriptions

The combined illumination of the following LEDs indicates a system condition:

- SID LEDs
- System power LED
- Health LED

SID LED status	Health LED status	System power LED status	Definition
Power supply (solid amber)	Flashing red	Solid amber	One or more of the following conditions exist: <ul style="list-style-type: none"> • Only one power supply is installed and that power supply is in standby. • Power supply fault. • System board fault.
	Flashing amber	Solid green	One or more of the following conditions exist: <ul style="list-style-type: none"> • Redundant power supply is installed and only one power supply is functional. • AC power cord is not plugged into redundant power supply. • Redundant power supply fault. • Power supply mismatch at POST or power supply mismatch through hot-plug addition.
PCI riser (solid amber)	Flashing red	Solid green	The PCI riser cage is not seated properly.
Over temp (solid amber)	Flashing amber	Solid green	The Health Driver has detected a cautionary temperature level.
	Flashing red	Solid amber	The server has detected a hardware critical temperature level.
Power cap (solid green)	—	Solid green	Power is available.
Power cap (solid green)	—	Flashing green	Waiting for power
Power cap (flashing amber)	—	Solid amber	Power is not available.
Power cap (off)	—	Solid amber	Standby
Processor (solid amber)	Flashing red	Solid amber	One or more of the following conditions might exist: <ul style="list-style-type: none"> • Processor in socket X has failed. • Processor X is not installed in the socket. • Processor X is unsupported. • ROM detects a failed processor during POST.
	Flashing amber	Solid green	Processor in socket X is in a pre-failure condition.
Fan (solid amber)	Flashing amber	Solid green	One fan has failed or has been removed.
	Flashing red	Solid green	Two or more fans have failed or been removed.
DIMM (solid amber)	Flashing red	Solid green	One or more DIMMs have failed.
	Flashing amber	Solid green	DIMM in slot X is in a pre-failure condition.

Drive bay numbering



CAUTION

When a server is purchased without any drive installed, some drive bays might be empty while other drive bays might be populated with drive blanks. To maintain proper system cooling, do not operate the server without a drive or a drive blank installed.

Subtopics

[SFF drive bay numbering](#)

[LFF drive bay numbering](#)

[E3.S drive bay numbering](#)

Mixed drive bay numbering

GPU-optimized configuration drive bay numbering

SFF drive bay numbering

The following drive backplane options are supported:

2 SFF drive backplanes:

- 2 SFF 16G x4 U.2 NVMe UBM4 BC
- 2 SFF 16G x4 U.2 NVMe UBM6 BC
- 2 SFF 24G x4 U.3 NVMe / SAS UBM4 BC
- 2 SFF 24G x4 U.3 NVMe / SAS UBM6 BC
- 2 SFF 16G x4 NVMe UBM10 BC (stacked)
- 2 SFF 16G x4 NVMe UBM11 BC (stacked)

8 SFF drive backplanes:

- 8 SFF 16G x4 U.2 NVMe / SAS UBM4 BC
- 8 SFF 16G x4 U.2 NVMe / SAS UBM6 BC
- 8 SFF 24G x1 U.3 NVMe /SAS UBM3 BC
- 8 SFF 24G x1 U.3 NVMe / SAS UBM6 BC
- 8 SFF 24G x4 U.3 NVMe / SAS UBM3 BC
- 8 SFF 24G x4 U.3 NVMe / SAS UBM 6 BC

For more information on the drive backplane description, see [Drive backplane naming](#).

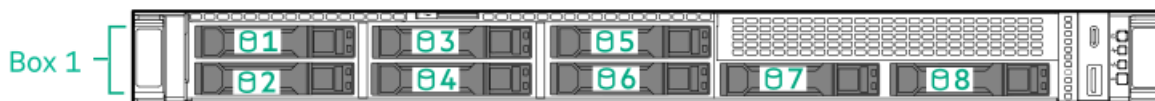

8 + 2 SFF drive bay numbering

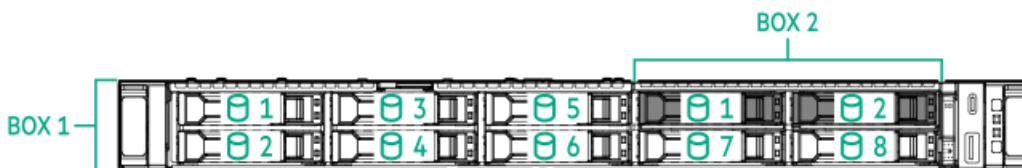

10 SFF drive bay numbering



LFF drive bay numbering

The following drive backplane options are supported:

- 4 LFF 12G x1 U.2 SAS UBM2 BC
- 4 LFF 12G x1 U.2 SAS UBM6 BC

For more information on the drive backplane description, see [Drive backplane naming](#).

4 LFF

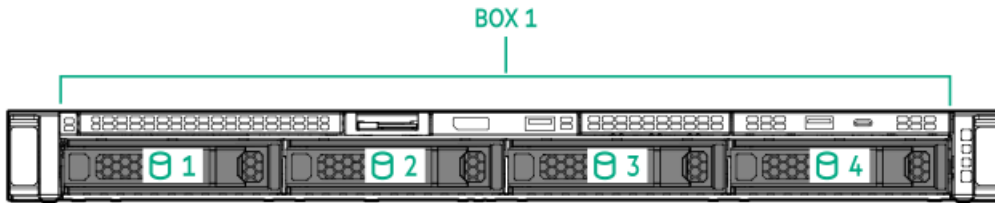

12 LFF

Drive box numbering

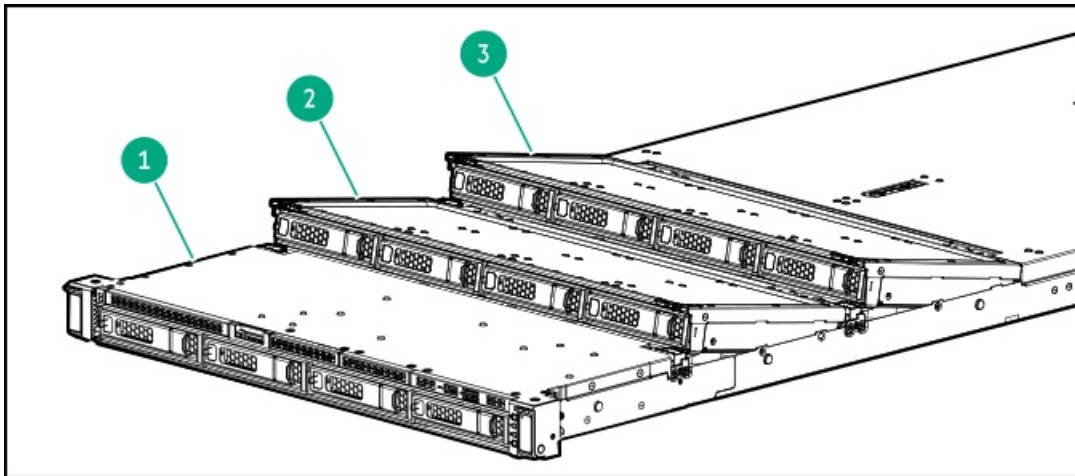

Item	Description
1	Box 1
2	Box 3
3	Box 5

Drive bay numbering

- Box 1

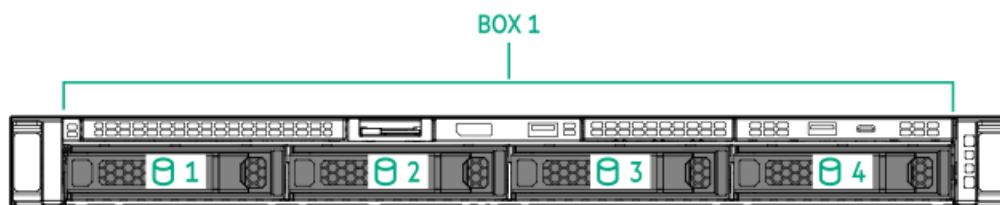

- Box 3 and 5

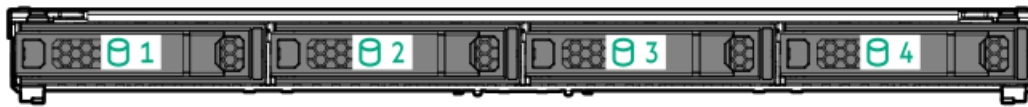

E3.S drive bay numbering

The following drive backplane options are supported:

- 2 E3.S 32G x8 NVMe UBM10 BC
- 4 E3.S 32G x4 NVMe UBM10 BC
- 4 E3.S 32G x4 NVMe UBM11 BC

For more information on the drive backplane description, see [Drive backplane naming](#).

20 E3.S drive bay numbering



Mixed drive bay numbering

The following drive backplane options are supported:

2 SFF drive backplanes:

- 2 SFF 16G x4 NVMe UBM10 BC (stacked)
- 2 SFF 16G x4 NVMe UBM11 BC (stacked)

4 E3.S drive backplanes:

- 4 E3.S 32G x4 NVMe UBM10 BC
- 4 E3.S 32G x4 NVMe UBM11 BC

8 SFF + 4 E3.S drive bay numbering



GPU-optimized configuration drive bay numbering

The following drive backplanes are supported:

2 SFF drive backplanes:

- 2 SFF 16G x4 NVMe UBM10 BC (stacked)
- 2 SFF 16G x4 NVMe UBM11 BC (stacked)

E3.S drive backplanes:

- 4 E3.S 32G x4 NVMe UBM10 BC
- 4 E3.S 32G x4 NVMe UBM11 BC

For more information on the drive backplane description, see [Drive backplane naming](#).

4 SFF drive bay numbering

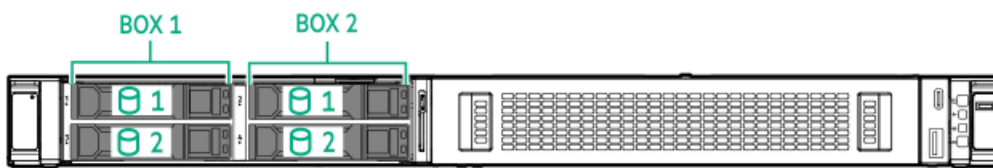

8 E3.S drive bay numbering

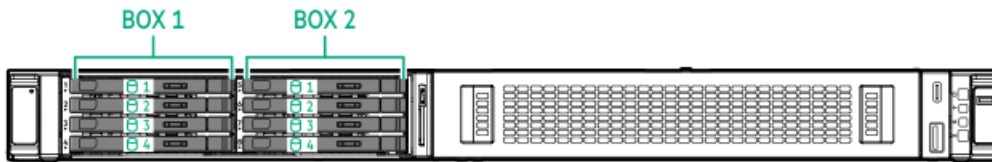

HPE Basic Drive LED definitions

The HPE Basic drive carrier has the following LEDs:

- Amber/blue LED—Managed by the drive backplane in conjunction with the storage controller and is used to indicate drive status.
- Green LED—Managed by the drive itself and indicates the drive activity.

The SFF basic drive carrier supports hot-plug NVMe.

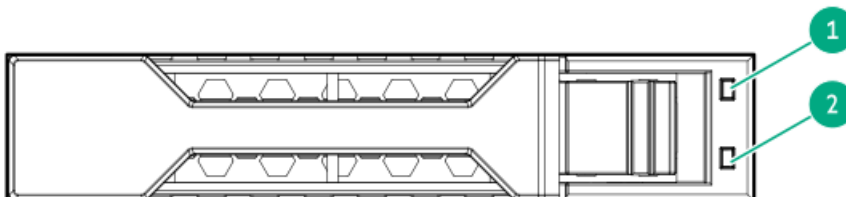

Item	LED	State	Definition
1	Fault/Locate	Solid amber	This drive has failed, is unsupported, or is invalid.
		Solid blue	The drive is operating normally and being identified by a management application.
		Flashing amber/blue (1 flash per second)	The drive has failed, or a predictive failure alert has been received for this drive. The drive has also been identified by a management application.
		Flashing amber (1 flash per second)	A predictive failure alert has been received for this drive. Replace the drive as soon as possible.
		Off	The drive is operating normally and not being identified by a management application.
2	Online/Activity	Solid green	The drive is online and has no activity.
		Flashing green (1 flash per second)	The drive is doing one of the following: <ul style="list-style-type: none"> Rebuilding or performing a RAID Performing a stripe size migration Performing a capacity expansion Performing a logical drive extension Erasing Spare part activation
		Flashing green (4 flashes per second)	The drive is operating normally and has activity.
		Off	The drive is not configured by a RAID controller or is a spare drive.

EDSFF SSD LED definitions

The EDSFF drive carrier has two LEDs:

- Amber/blue LED—Managed by the drive backplane in conjunction with the storage controller and is used to indicate drive status.
- Green LED—Managed by the drive itself and indicates the drive activity.



Item	LED	State	Definition
1	Fault/Locate	Solid amber	This drive has failed, is unsupported, or is invalid.
		Solid blue	The drive is operating normally and being identified by a management application.
		Flashing amber/blue (1 flash per second)	The drive has failed, or a predictive failure alert has been received for this drive. The drive has also been identified by a management application.
		Flashing amber (1 flash per second)	A predictive failure alert has been received for this drive. Replace the drive as soon as possible.
		Off	The drive is operating normally and not being identified by a management application.
2	Online/Activity	Solid green	The drive is online and has no activity.
		Flashing green (4 flashes per second)	The drive is operating normally and has activity.
		Off	No power present.

GPU riser slot numbering

This server supports 4 single-width GPUs and 2 dual-width GPUs with 4 SFF SAS/ SATA/ NVMe drives or 8 E3.S drives.

4 single-width GPUs



2 double-width GPUs

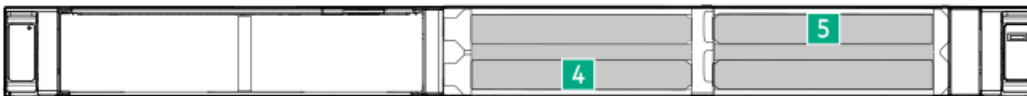

Drive backplane naming

This topic explains the features represented in the drive backplane naming. This naming convention was adopted starting in the HPE Gen11 server release. Your server might not support all the features listed in this topic. For server-specific support information, see the server guides:

- Drive backplane support, see [Drive bay numbering](#).
- Drive backplane cabling, see [Storage cabling](#).



Item	Description	Values
1	Drive bay count	Number of drive bays supported by the backplane.
2	Drive form factor	LFF—Large Form Factor SFF—Small Form Factor E3S—Enterprise and Datacenter Standard Form Factor (EDSFF E3.S)
3	Maximum link rate per lane (GT/s)	12G 16G 24G 32G
4	Port link width and interface	x1 NVMe/SAS—U.3 NVMe, SAS, or SATA ¹ x4 NVMe/SAS—U.3 NVMe, SAS, or SATA ² x4 NVMe—NVMe ³ x4 NVMe—E3.S
5	Universal backplane manager (UBM) model	The UBM model defines the UBM firmware used by the backplane. Examples of UBM models: UBM2, UBM3, and etc.
6	Drive carrier type	BC—Basic carrier (SFF) LP—Low-profile carrier (LFF) EC—E3.S carrier

- ¹ Tri-mode controller support for x1 U.3 NVMe, SAS, and SATA drives. System board connection supports SATA drives only.
² CPU direct attach or tri-mode controller support for x4 U.3 NVMe, x2 (via a splitter cable) U.3 NVMe, or x1 SAS and SATA drives.
³ CPU direct attach or tri-mode controller support for x4 NVMe drives.

Fan numbering

To provide sufficient airflow to the system, the server has seven high performance fans.

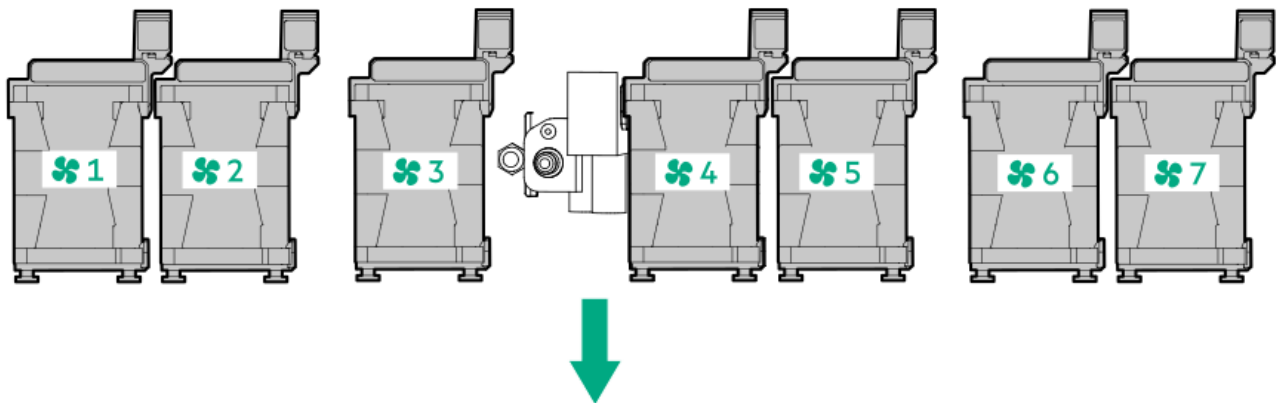

The arrow points to the front of the server.

Heatsink and processor socket components

A standard heatsink is shown. Your heatsink might look different.

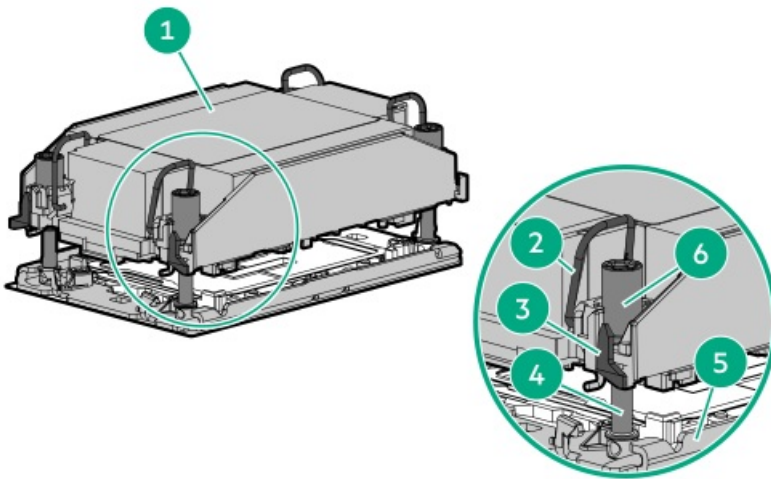

Item	Description
1	Processor-heatsink module *
2	Anti-tilt wires
3	Processor carrier release tabs
4	Bolster plate guide posts
5	Bolster plate
6	Heatsink screws

* This module consists of the heatsink attached to the processor that is already secured in its carrier.

Closed-loop liquid cooling components

When Intel Xeon processor with $270\text{ W} < \text{TDP} \leq 350\text{ W}$ is installed, the closed-loop liquid cooling heatsink and liquid cooling fans options are required.

- The pump-cold plate of the liquid cooling heatsink picks up heat from the processor.
- Heat is transferred to the radiator through the coolant tubes.
- The coolant tubes and liquid cooling fans work together to cool down the system. The coolant is a mixture of purified water and ethylene glycol with additional additives for corrosion resistance.



NOTE

The coolant in the liquid cooling module contains anti-corrosion additives which could degrade over time resulting in potential leaks in the system. To protect the system, HPE recommends replacing the module every five years. For additional information, contact your local HPE representative.



CAUTION

Heatsink coolant leakage

- The hoses of the closed-loop liquid cooling (CLLC) module are prefilled with coolant. iLO automatically detects if a coolant leakage occurs and:
 - Sends an iLO REST alert and SNMP trap
 - Records the event in the Integrated Management Log (IML)
 - Furthermore, the system initiates an immediate shutdown and iLO:
 - Prevents power-on until the leakage event is cleared, and REST API is performed for system recovery. For more information on clearing the leakage event using the iLO web interface or RESTful API, see the iLO user guide (<https://www.hpe.com/support/hpeilodocs-quicklinks>).
- If a coolant leakage occurs, follow the recommended procedure in Appendix I: Server coolant spill response of the server maintenance guide . Do not attempt to replace the coolant in the CLLC module. For service inquiries, contact your local service provider.

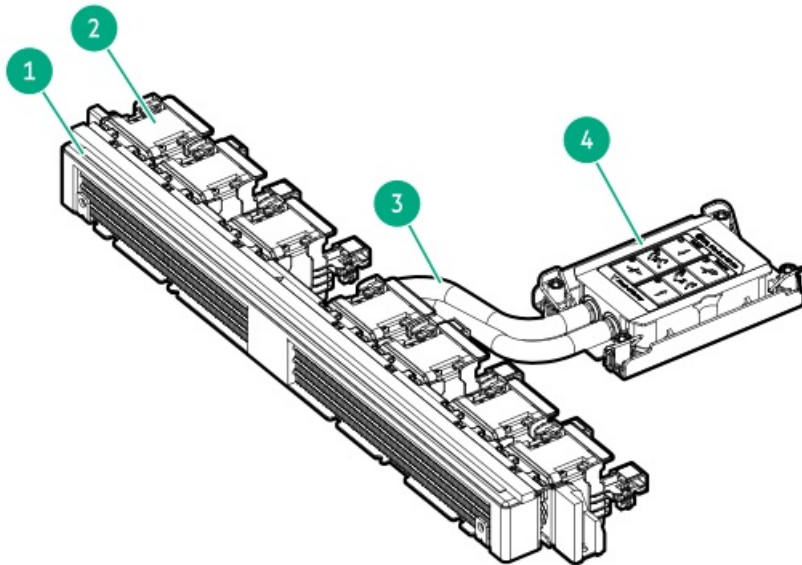

Item	Description
1	Radiator
2	Liquid cooling fans (7, single-rotor)
3	Coolant tubes ¹
4	Pump-cold plate

¹ The liquid cooling heatsink has two pumps for redundancy.

Liquid cooling guidelines

The closed-loop liquid cooling (CLLC) module hoses are prefilled with coolant. The coolant is a mixture of purified water and ethylene glycol with additional corrosion-resistant additives. The direct liquid cooling (DLC) module coolant is fed into the hoses through the rack manifolds.

CLLC module lifespan

HPE recommends replacing the module every five years. The coolant anti-corrosion additives degrade over time resulting in potential leaks

in the system. For additional information on protecting the system, contact your local HPE representative.

Coolant leakage detection

If a liquid cooling module coolant leakage occurs, the following happens:

- iLO automatically detects it and:
 - Sends an iLO REST alert and Simple Network Management Protocol (SNMP) trap
 - Records the event in the Integrated Management Log (IML)
- The system initiates an immediate shutdown. The system will not power on until the leakage event is cleared, and a REST API operation for system recovery is performed.
- Follow the recommended procedure in Appendix I: Server coolant spill response of the server maintenance guide.

Do not attempt to replace the coolant in the CLLC module. For service inquiries, contact your local service provider.

Storage temperature

When storing a server with a liquid cooling module, maintain a temperature of -10°C to 60°C (14°F to 140°F). Allowing the liquid cooling module coolant to freeze can damage its metallic microstructures.

Facility water supply temperature

To maintain optimal cooling performance and prevent equipment damage from overheating:

- Do not allow the facility water supply temperature to exceed 40°C (104°F).
- Monitor environmental conditions year-round to anticipate temperature fluctuations.
- Install insulated plumbing as needed to ensure the water supply remains at or below 40°C (104°F).

Fan and heatsink requirements



CAUTION

To maintain proper system cooling, install the correct fan and heatsink types required for specific hardware configurations.

The table lists the fan and heatsink requirements for the server depending on the drive configuration and hardware options. For more detailed information, see the product QuickSpecs on the Hewlett Packard Enterprise website (<https://www.hpe.com/info/quickspecs>).

8 SFF and 4 LFF drive configurations

Processor TDP	Fan	Heatsink
≤ 185 W	Standard	Standard
185 W < Processor TDP ≤ 270 W	Performance	Performance
270 W < Processor TDP ≤ 350 W	Liquid cooling	Closed-loop liquid cooling

1

The maximum recommended ambient operating temperature is 27°C.

12 LFF drive and GPU configurations

Processor TDP	Fan	Heatsink
≤ 185 W	Performance	Standard
185 W < Processor TDP ≤ 270 W	Performance	Performance
270 W < Processor TDP ≤ 350 W	Liquid cooling	Closed-loop liquid cooling

Hardware options

To maintain proper system cooling, make sure to use a performance fan and a standard or performance heatsink for the following hardware options:

- Energy pack
- E3.S / NVMe / SAS4 drives / HPE NS204i-u Boot Device V2 v2
- 96 GB or higher capacity DIMMs *
- Type-p Ethernet adapters or type-o InfiniBand adapters with 100/200 Gb speed
- OCP NIC 3.0 adapters with 100/200 Gb speed
- GPU cards

Datacenter Secure Control Module components

This server is a Datacenter Modular Hardware System (DC-MHS)-based product.

- The processors and DIMMs on the system board provide the compute function. The system board serves as the Host Processor Module (HPM).
- The iLO and the Trusted Platform Module 2.0 (TPM 2.0) chipsets embedded on the Datacenter Secure Control Module (DC-SCM) provide this server's manageability and security functions. This module also has the connector for the serial port option.

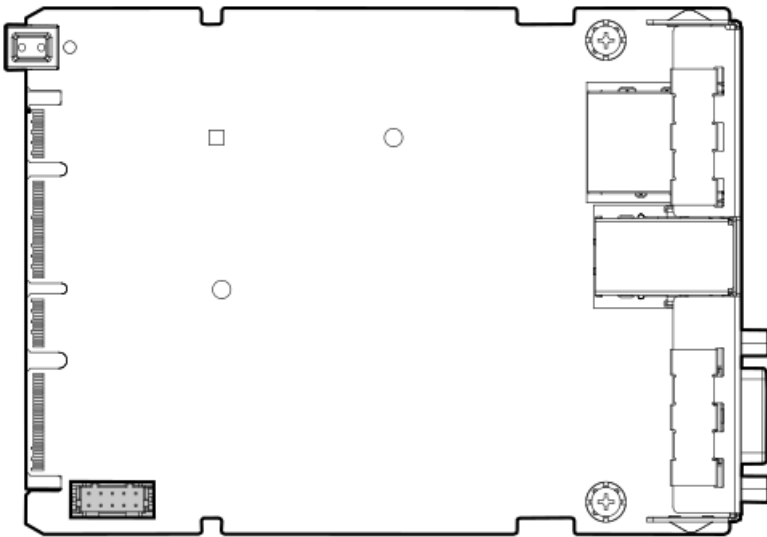

OCP NIC 3.0 slot numbering

This server supports up to two OCP NIC 3.0 slots in either the rear or the front panel.

Rear OCP NIC 3.0 slots

The rear OCP NIC 3.0 slots are standard in the system.



Item	Slot number	Supported options
1	Slot 20 OCP A PCIe5 x16	<ul style="list-style-type: none">• OCP NIC adapter• Type-o storage controller
2	Slot 21 OCP B PCIe5 x16	

1

When installing a single OCP NIC adapter, install it in Slot 20 OCP A.

Front OCP NIC 3.0 slots

The front OCP NIC 3.0 slots are in box 3. They require the front OCP enablement option kits (Bay 1: P77261-B21, Bay 3: P76982-B21) and support NIC adapter options.

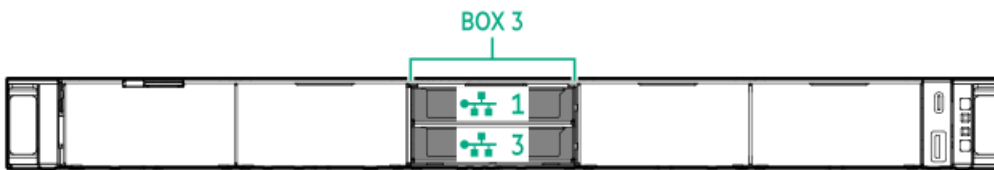

Bay	Slot number
1	OCP slot PCIe5 x16
3	

HPE NS204i-u Boot Device V2 components

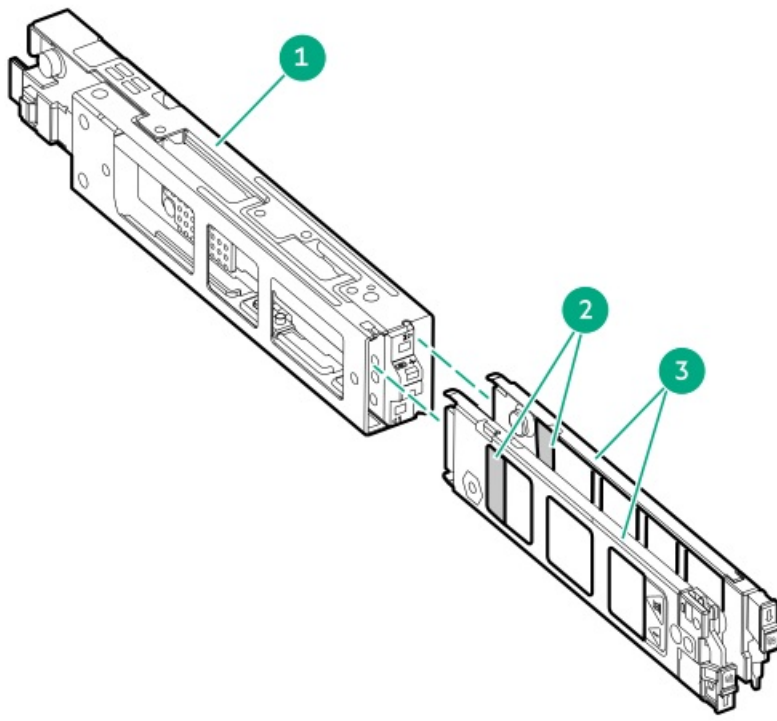

Item	Description
1	Boot device cage
2	M.2 slots
3	Boot device carriers

HPE NS204i-u Boot Device V2 LED definitions

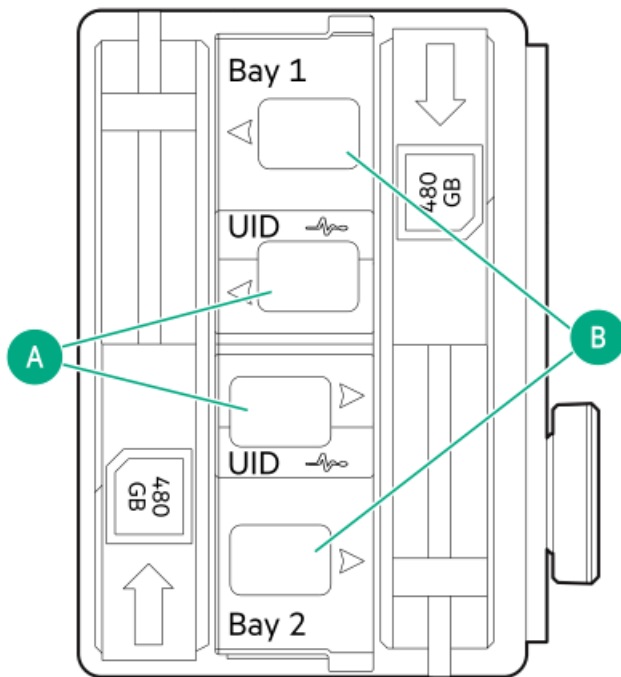

**NOTE**

The bay number can be found on the SSD carrier handle.

Item	LED	Status	Definition
A	Fault or Locate	Solid amber	Drive has failed, unsupported, or invalid.
		Solid blue	Drive is operating normally.
		Flashing amber or blue (one flash per second)	Drive has failed, or a predictive failure alert is received for the drive.
		Flashing amber (one flash per second)	Drive predictive failure alert is received. Replace the drive as soon as possible.
		Off	Drive is operating normally and is not identified by any application.
B	Online/Activity	Solid green	Drive is online and has no activity.
		Flashing green (one flash per second)	Drive is doing one of the following: <ul style="list-style-type: none"> • Rebuilding or performing a RAID • Erasing
		Flashing green (4 flashes per second)	Drive is operating normally and has activity.
		Off	Drive is not configured by a RAID controller.

Riser board components

One-slot PCIe x16 riser board

This riser board supports PCIe5 x16 (16, 8, 4, 2) and full-height, half-length expansion cards.

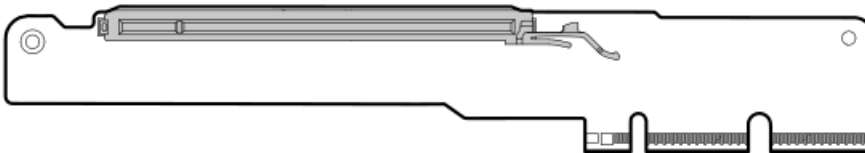

Two-slot PCIe x16 captive riser board

This riser board supports single-width, full-height, full-length form factors in the GPU-optimized drive configurations.

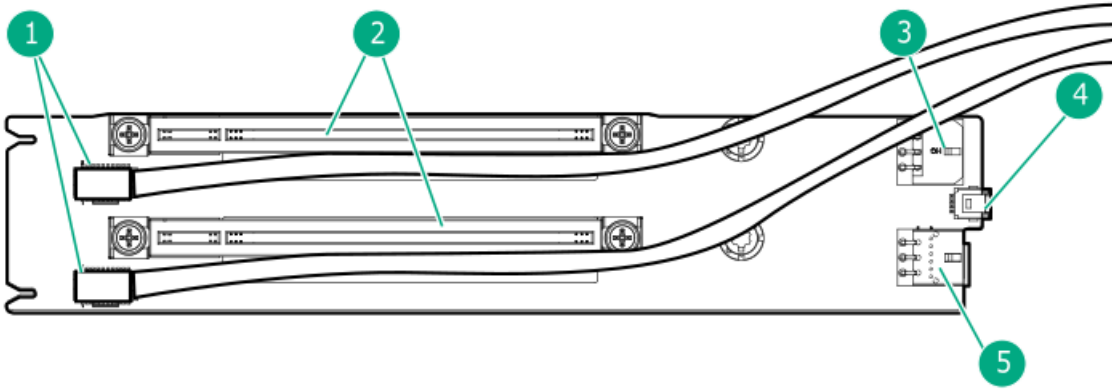

Item	Description
1	PCIe slots sideband signal connectors
2	PCIe5 x16 (16, 8, 4, 2)
3	GPU auxiliary power connector
4	GPU sideband connector
5	Captive riser power connector

Troubleshooting

Subtopics

[NMI functionality](#)

[Front panel LED power fault codes](#)

[Troubleshooting resources](#)

NMI functionality

An NMI crash dump enables administrators to create crash dump files when a system is not responding to traditional debugging methods.

An analysis of the crash dump log is an essential part of diagnosing reliability problems, such as hanging operating systems, device drivers, and applications. Many crashes freeze a system, and the only available action for administrators is to cycle the system power. Resetting the system erases any information that could support problem analysis, but the NMI feature preserves that information by performing a memory dump before a hard reset.

To force the OS to initiate the NMI handler and generate a crash dump log, the administrator can use the iLO Generate NMI feature.

Front panel LED power fault codes

The following table provides a list of power fault codes, and the subsystems that are affected. Not all power faults are used by all servers.

Subsystem	LED behavior
System board	1 flash
Processor	2 flashes
Memory	3 flashes
Riser board PCIe slots	4 flashes
OCP adapter	5 flashes
Storage controller	6 flashes
System board PCIe slots	7 flashes
Power backplane	8 flashes
Storage backplane	9 flashes
Power supply	10 flashes
PCIe expansion cards installed in riser board	11 flashes
Chassis	12 flashes
GPU card	13 flashes

Troubleshooting resources

If you need help troubleshooting, see the latest articles for your server.

<https://www.hpe.com/info/dl320gen12-ts>

Cabling

This chapter includes cabling guidelines and diagrams for internal component cabling.

Subtopics

[Cabling guidelines](#)

[Internal cabling management](#)

[Cabling diagrams](#)

[Storage cabling](#)

[Fan cabling](#)

[Closed-loop liquid cooling heatsink cabling](#)

[HPE NS204i-u Boot Device V2 cabling](#)

[GPU cabling](#)

[Serial port cabling](#)

[Optical drive cabling](#)

[Display port cabling](#)

[Systems Insight Display cabling](#)

[Front OCP NIC and PHY board cabling](#)

[Rear OCP upgrade cabling](#)

[Front I/O cabling](#)

[Chassis intrusion detection switch cabling](#)

Cabling guidelines

Observe the following:



NOTE

The colors in the cabling diagrams are for illustration purposes only.



CAUTION

To avoid damaging connectors, avoid repeated installation and removal of cables. Excessive handling can shorten the lifespan of the cable.

- For cable option kits, see the product QuickSpecs.
- For cable spare part numbers, see the Illustrated parts catalog in the maintenance and service guide.
- Some diagrams show alphabetical callouts such as A, B, C, etc. These callouts correspond to labels near the connectors on the cable.
- Some cables have more than one connector, such as a Y-cable, but not all connectors are used.
- Observe all guidelines when working with server cables.

Before connecting cables

- Note the port labels on the PCA components. Not all these components are used by all servers:
 - System board ports
 - Drive and power supply backplane ports
 - Expansion board ports (controllers, retimers, adapters, expanders, risers, and similar boards)
- Note the label near each cable connector. This label indicates the destination port for the cable connector.
- Some data cables are prebent. Do not unbend or manipulate the cables.
- To prevent mechanical damage or depositing oil that is present on your hands, and other contamination, do not touch the ends of the connectors.

When connecting cables

- Before connecting a cable to a port, lay the cable in place to verify the length of the cable.
- Use the internal cable management features to properly route and secure the cables.
- When routing cables, be sure that the cables are not in a position where they can be pinched or crimped.
- Avoid tight bend radii to prevent damaging the internal wires of a power cord or a server cable. Never bend power cords and server cables tight enough to cause a crease in the sheathing.
- Make sure that the excess length of cables is properly secured to avoid excess bends, interference issues, and airflow restriction.
- Before installing a new component or closing up the server, make sure that all cables are in their appropriate routing position. This cable check prevents component damage and potential signal interference.

When disconnecting cables

- Grip the body of the cable connector. Do not pull on the cable itself because this action can damage the internal wires of the cable or the pins on the port.
- If a cable does not disconnect easily, check for any release latch that must be pressed to disconnect the cable.

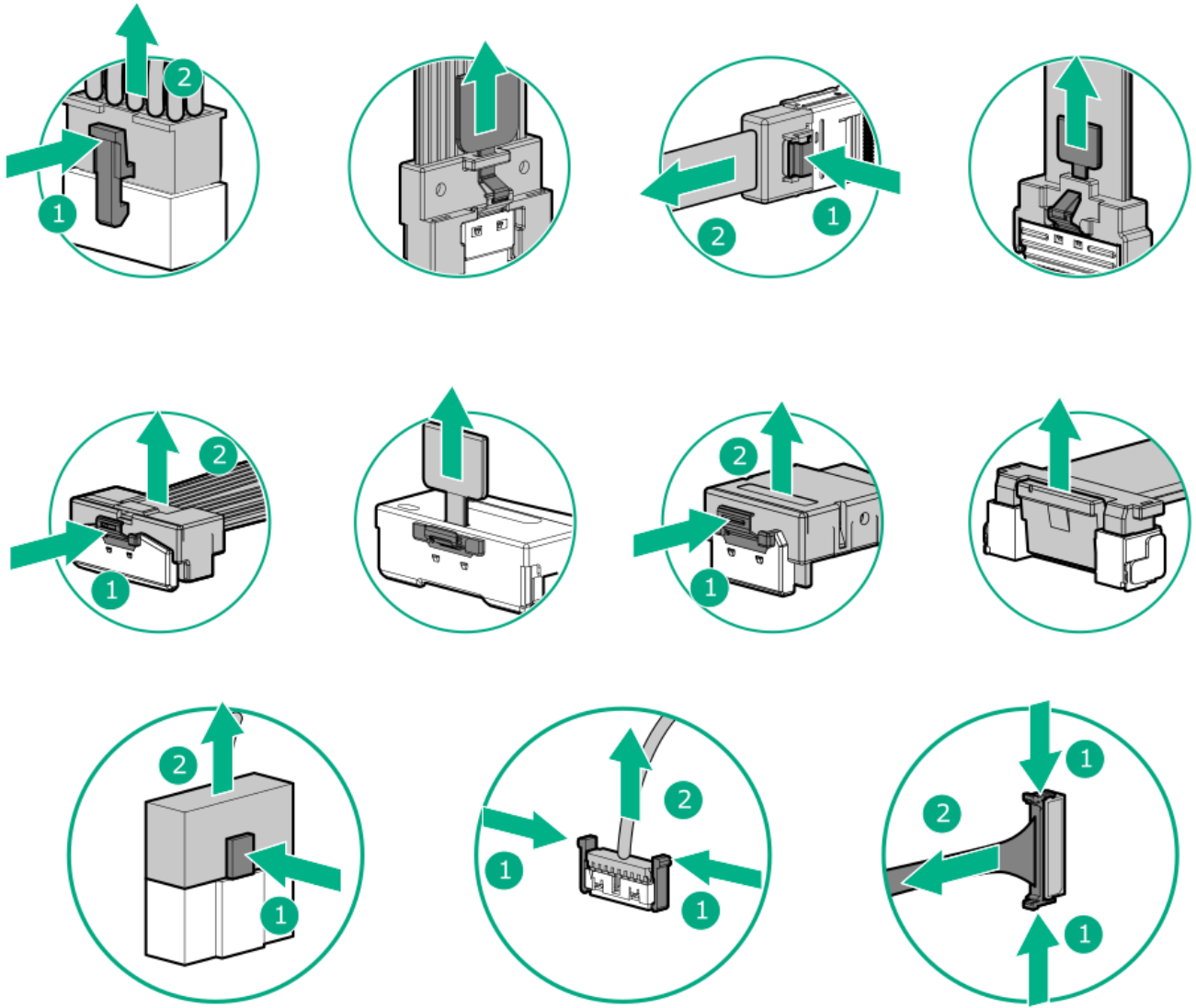

- Remove cables that are no longer being used. Retaining them inside the server can restrict airflow. If you intend to use the removed cables later, label and store them for future use.

Internal cabling management



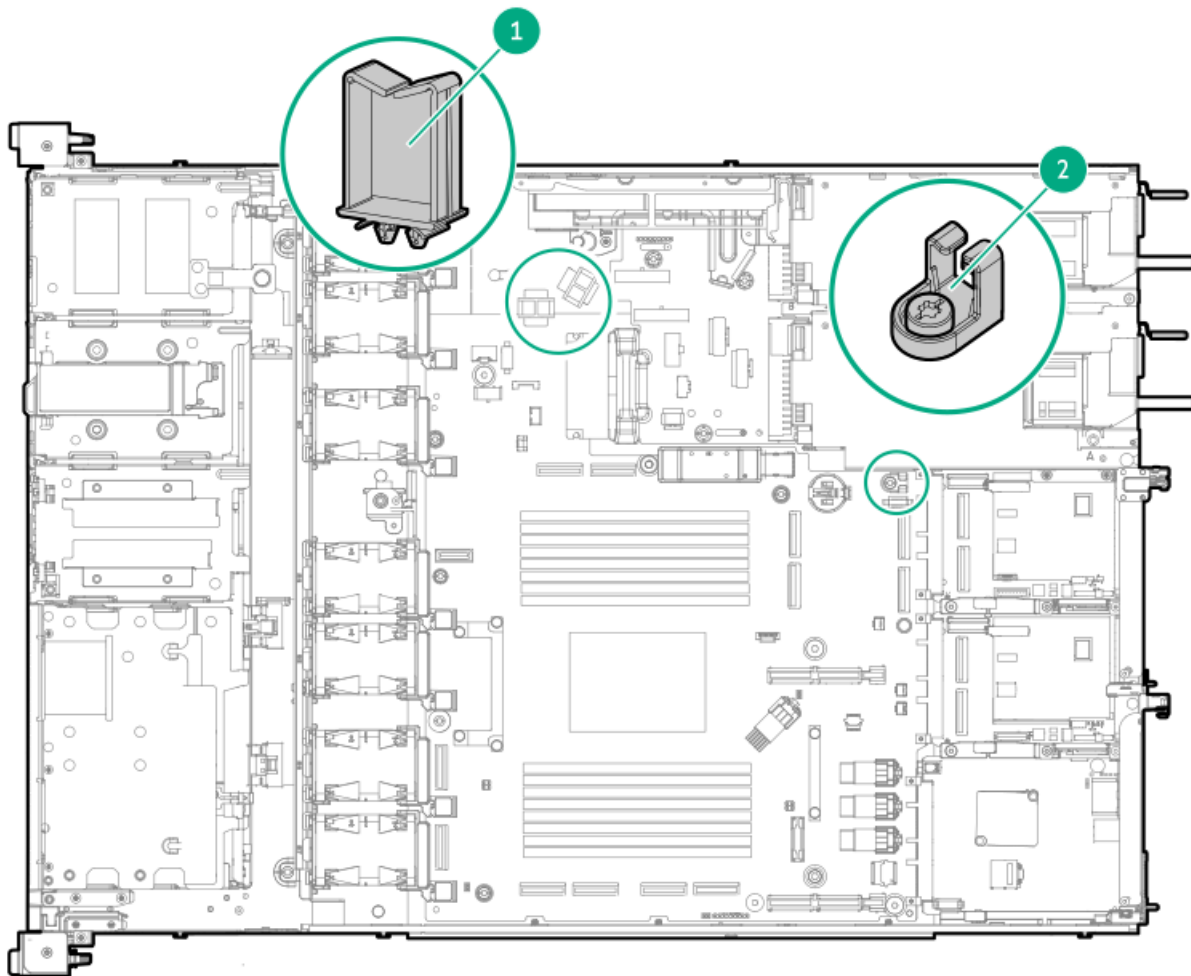

Item	Description
1	Cable clips
2	Serial port cable clamp

Cabling diagrams

Observe the following:

- Before cabling components, see the [Cabling guidelines](#).
- Use the cable part number or search feature to find your diagram.

Component cabling	Cable part number
Drive power cabling	—
2 SFF drive power cabling	P54591-001
8 SFF drive power cabling	P71911-001
Mixed drive power cabling	<ul style="list-style-type: none"> • P75582-001 • P75586-001

Component cabling	Cable part number
4 LFF drive power cabling	P75584-001
12 LFF drive power cabling	<ul style="list-style-type: none"> • P75585-001 • P75584-001 • P75583-001
GPU-optimized drive power cabling	P75582-001
SFF drive controller cabling	—
8 SFF drive: Direct-attached cabling	P75908-001
8 SFF drive: Type-p controller cabling	P75590-001
8 SFF drive: Direct attached cabling	<ul style="list-style-type: none"> • P71912-001 • P71910-001
8 + 2 SFF drive: Primary type-p controller cabling	<ul style="list-style-type: none"> • P45611-001 • P53972-001
2 SFF drive: Secondary riser connector cabling	P74810-001
8 + 2 SFF drive: Type-o controller cabling	<ul style="list-style-type: none"> • P48961-001 • P48960-001
LFF drive controller cabling	—
4 LFF drive: Type-o controller cabling	P53989-001
4 LFF drive: Primary type-p controller cabling	P54931-001
12 LFF drive: Primary type-p controller cabling	<ul style="list-style-type: none"> • P54930-001 • P54931-001
12 LFF drive: Type-o controller cabling	<ul style="list-style-type: none"> • P54928-001 • P53989-001
E3.S drive controller cabling	—
8 E3.S drive: Direct-attached cabling	P75592-001
8 E3.S drive: Primary and secondary riser connector cabling	<ul style="list-style-type: none"> • P75580-001 • P75577-001
4 SFF drive with a GPU riser cage: Primary riser type-p controller cabling	P75588-001
8 E3.S drive with a GPU riser cage: Secondary riser type-p controller cabling	P75590-001
8 E3.S drive with a GPU riser cage: MR932i-p controller cabling	P75575-001
4/16 E3.S drive: MR932i-p controller cabling	P75318-001
12 E3.S drive: MR932i-p controller cabling in the primary and secondary riser	P75318-001

Component cabling	Cable part number
16 E3.S drive: Primary and secondary riser connector cabling	<ul style="list-style-type: none"> • P75592-001 • P75580-001 • P75577-001 • P75578-001 • P75579-001
4/16 E3.S drive: Primary type-p controller cabling	P75590-001
4/16 E3.S drive: MR932i-p controller cabling	<ul style="list-style-type: none"> • P75318-001 • P75570-001
4/16 E3.S drive: Secondary type-p controller cabling	P75590-001
16 E3.S drive: MR932i-p controller cabling	P75581-001
20 E3.S drive: Direct-attached cabling	<ul style="list-style-type: none"> • P75592-001 • P75576-001 • P75504-001 • P75505-001
20 E3.S drive: MR932i-p controller cabling	P75581-001
20 E3.S drive: Type-p controller cabling	P75593-001
Mixed drive controller cabling	—
8 SFF drive: Type-o controller cabling	P75589-001
8 SFF + 4 E3.S drive: Onboard SAS/SATA/NVMe cabling	P75594-001
8 SFF + 4 E3.S drive: Type-p controller cabling	P75590-001
10 SFF drive: Direct attached cabling	<ul style="list-style-type: none"> • P75592-001 • P75580-001
GPU-optimized configuration drive controller cabling	—
4 SFF drive: Type-o controller cabling	<ul style="list-style-type: none"> • P75587-001 • P75589-001
4 SFF/16 E3.S drive: Primary type-p controller cabling	P75588-001
8 E3.S drive: Primary and secondary riser connector cabling	P75580-001
HPE NS204i-u Boot Device V2 cabling	—
HPE NS204i-u Boot Device V2 cabling with the boot device installed in the power supply bay	<ul style="list-style-type: none"> • P72024-001 • P63720-001
HPE NS204i-u Boot Device V2 cabling with the boot device installed next to the low-profile riser cage	<ul style="list-style-type: none"> • P63720-001 • P71913-001

Component cabling	Cable part number
HPE NS204i-u Boot Device V2 cabling with the boot device installed in box 3	<ul style="list-style-type: none"> • P48956-001 • P74730-001
4 LFF drive: HPE NS204i-u Boot Device V2 cabling with the boot device installed on the chassis	<ul style="list-style-type: none"> • P48956-001 • P72024-001
GPU-optimized configuration: HPE NS204i-u Boot Device V2 cabling with the boot device installed on the chassis	<ul style="list-style-type: none"> • P48956-001 • P74730-001
GPU cabling	—
GPU auxiliary power cabling	P75256-001
GPU riser power cabling	P75594-001
GPU riser signal cabling	<ul style="list-style-type: none"> • P71886-001 • P73415-001
Optical drive and DisplayPort cabling	—
8 SFF and mixed drive optical drive cabling	P73776-002
4 LFF drive optical drive cabling	P73776-002
SFF and E3.S drive DisplayPort cabling	P73948-001
LFF drive DisplayPort cabling	P73948-001
OCP cabling	—
Rear OCP upgrade cabling	<ul style="list-style-type: none"> • P75506-001 • P75507-001 • P73494-001
Front OCP NIC and PHY board cabling	—
Primary OCP	<ul style="list-style-type: none"> • P71941-001 • P73927-001
Secondary OCP	P71941-001
Rich I/O configuration: Primary OCP	<ul style="list-style-type: none"> • P71941-001 • P73927-001
Rich I/O configuration: Secondary OCP	P71941-001
Serial port cabling	—
Serial port cabling with the 60 mm power supply	<ul style="list-style-type: none"> • P73744-001 • P71826-001
Serial port cabling with the 73.5 mm power supply	<ul style="list-style-type: none"> • P73744-001 • P71826-001

Component cabling	Cable part number
Front I/O cabling	—
SFF / E3.S / 4 LFF drive	P71909-001
12 LFF drive front I/O cabling	P73417-001
Mixed drive front I/O cabling	P73417-001
Miscellaneous cabling	—
Fan cabling	P71914-001
System Insight Display cabling	P48971-001
Chassis intrusion detection switch cabling	869413-001

Storage cabling

Subtopics

[Drive power cabling](#)

[Storage controller cabling](#)

Drive power cabling

2 SFF drive power cabling

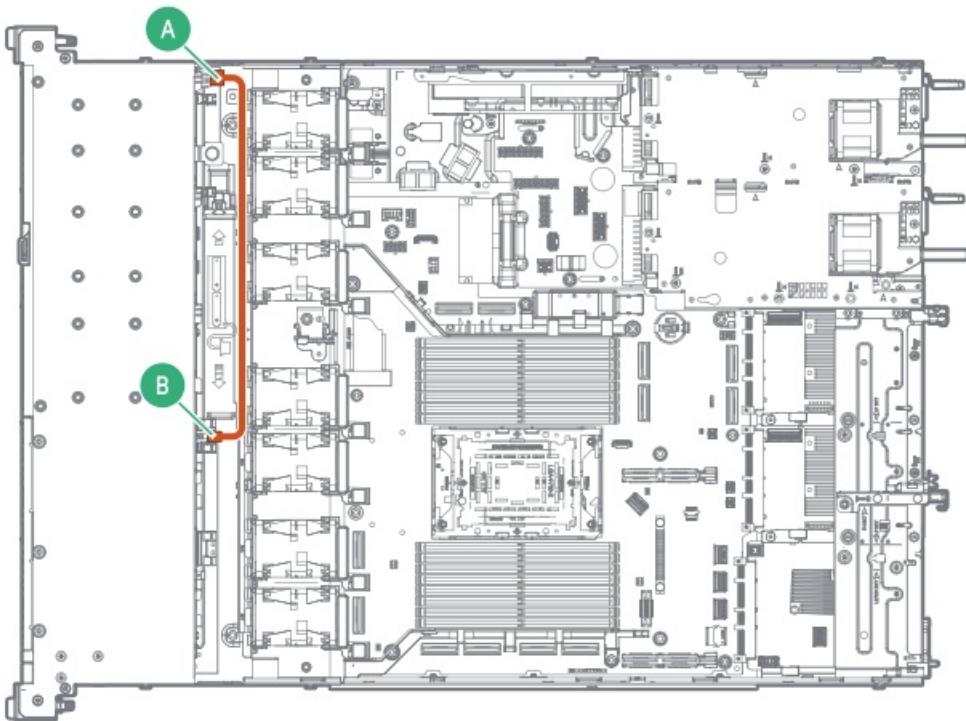

Cable part number	Color	From	To
P54591-001	Orange	2 SFF drive backplane power connector	8 SFF drive box 1 backplane power connector

8 SFF drive power cabling

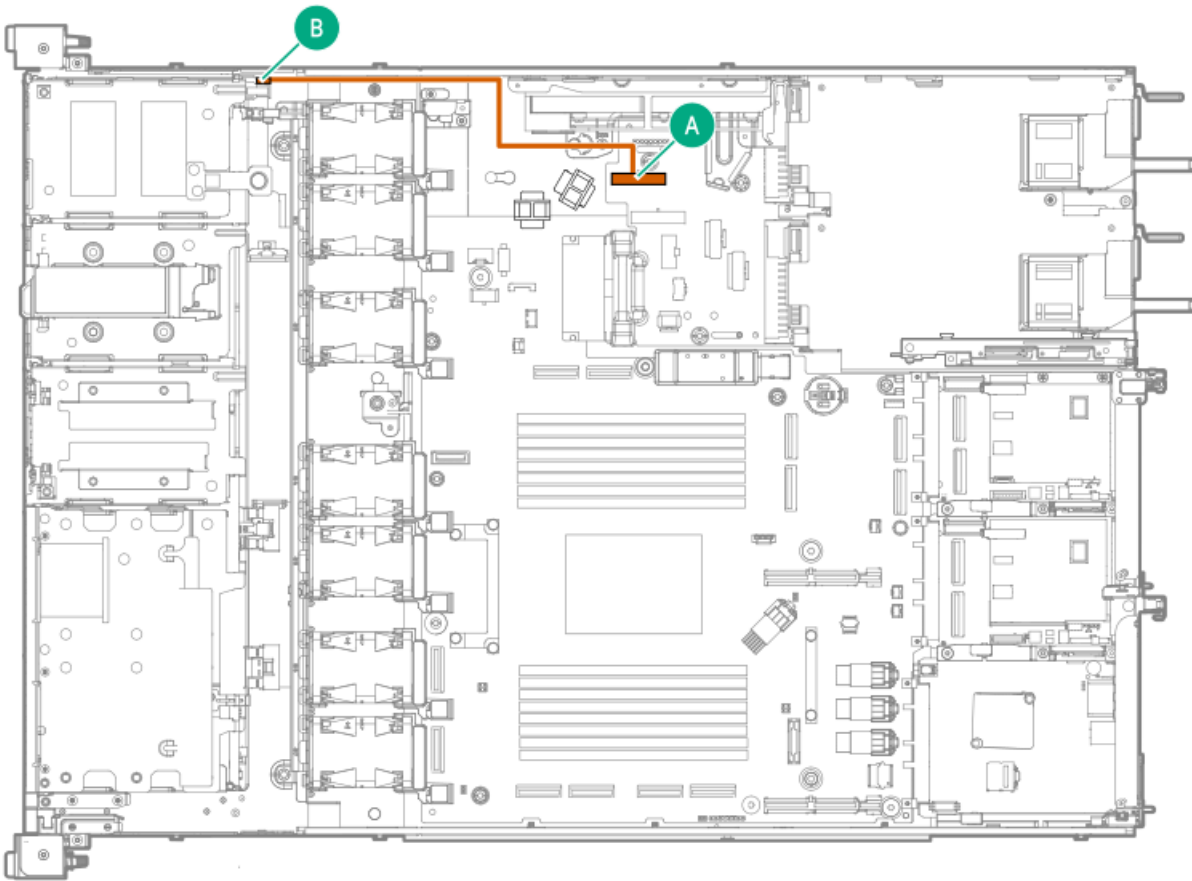

Cable part number	Color	From	To
P71911-001	Orange	8 SFF backplane power connector	Box 1, 2 drive backplane power connector

Mixed drive power cabling

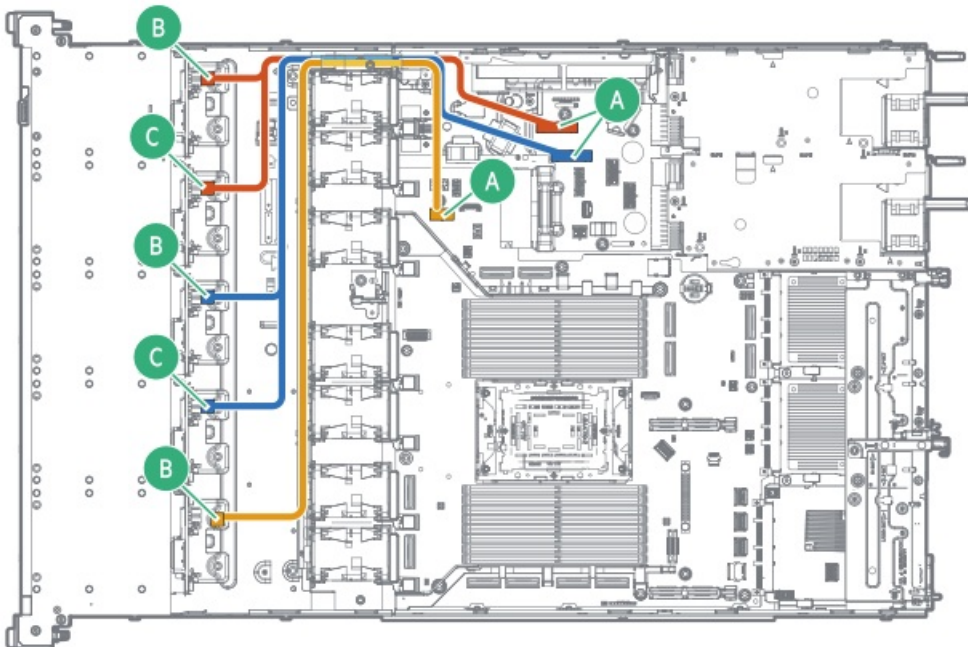

Cable part number	Color	From	To
P75582-001	Orange	Box 1 and box 2 drive power connector	Box 1, 2 drive backplane power connector
	Blue	Box 3 and 4 drive power connector	Box 3, 4 drive backplane power connector
P75586-001	Gold	Box 5 drive power connector	Box 5 drive backplane power connector

4 LFF drive power cabling

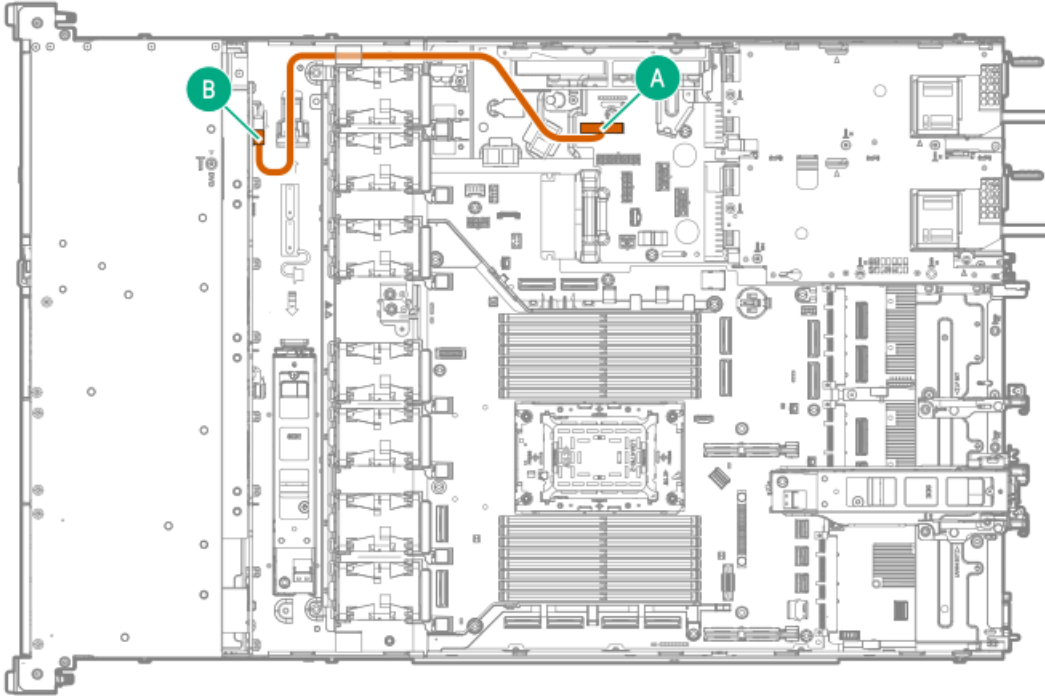

Cable part number	Color	From	To
P75584-001	Orange	4 LFF drive backplane power connector	Box 1, 2 drive backplane power connector

12 LFF drive power cabling

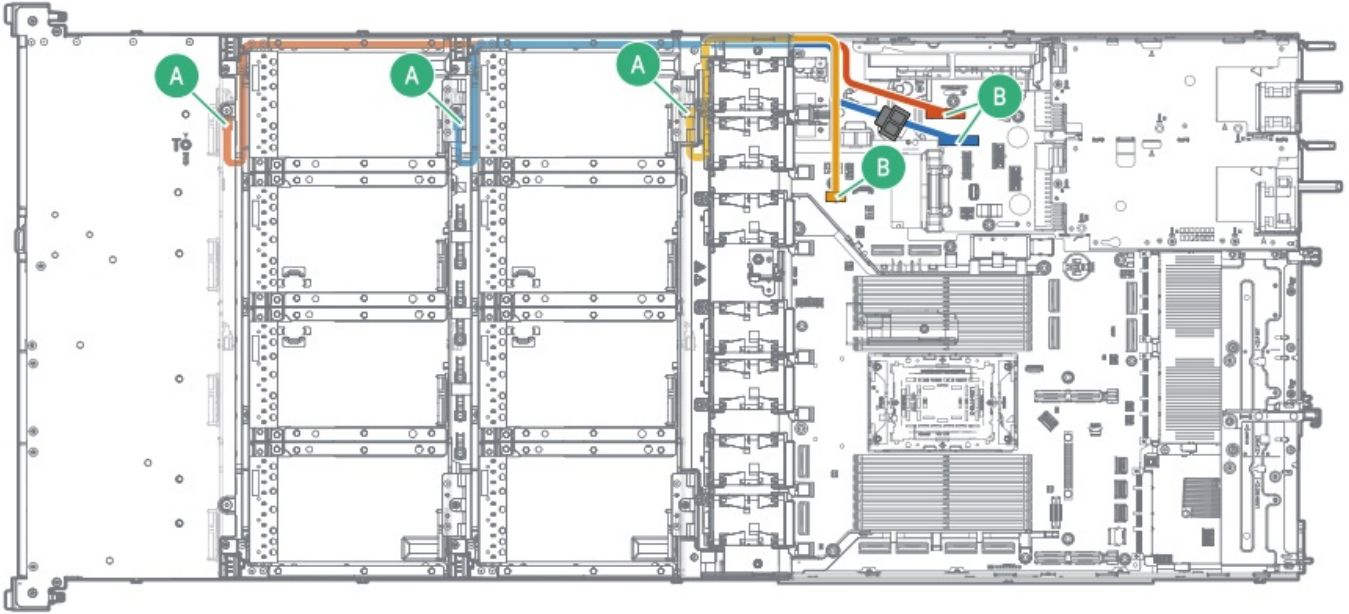

Cable part number	Color	From	To
P75585-001	Orange	4 LFF drive backplane power connector in box 1	Box 1, 2 drive backplane power connector
P75584-001	Blue	4 LFF drive backplane power connector in box 3	Box 3, 4 drive backplane power connector
P75583-001	Gold	4 LFF drive backplane power connector in box 5	Box 5 drive backplane power connector

GPU-optimized drive power cabling

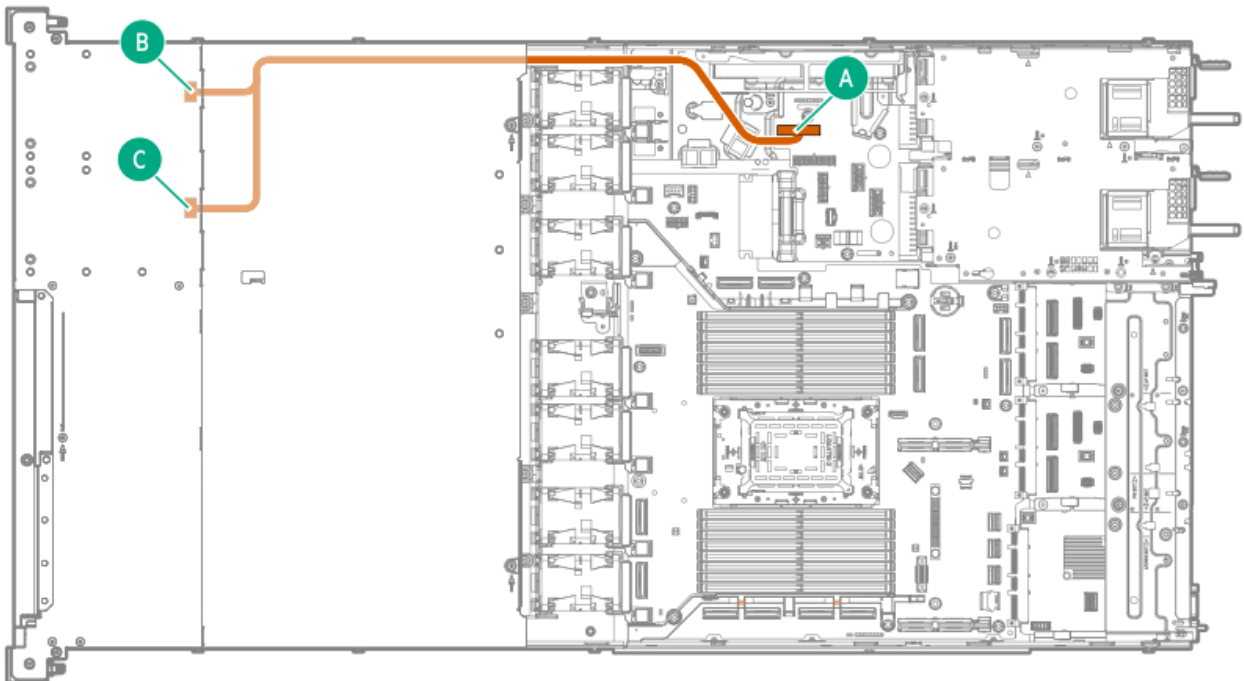

Cable part number	Color	From	To
P75582-001	Orange	4 E3.S drive backplane drive power connector in box 1 and box 2	Box 1, 2 drive backplane power connector

Storage controller cabling

Subtopics

[SFF drive controller cabling](#)

[LFF drive controller cabling](#)

[E3.S drive controller cabling](#)

[Mixed drive controller cabling](#)

[GPU-optimized configuration drive controller cabling](#)

[Energy pack cabling](#)

[Storage controller backup power cabling](#)

SFF drive controller cabling

8 SFF drive: Direct-attached cabling

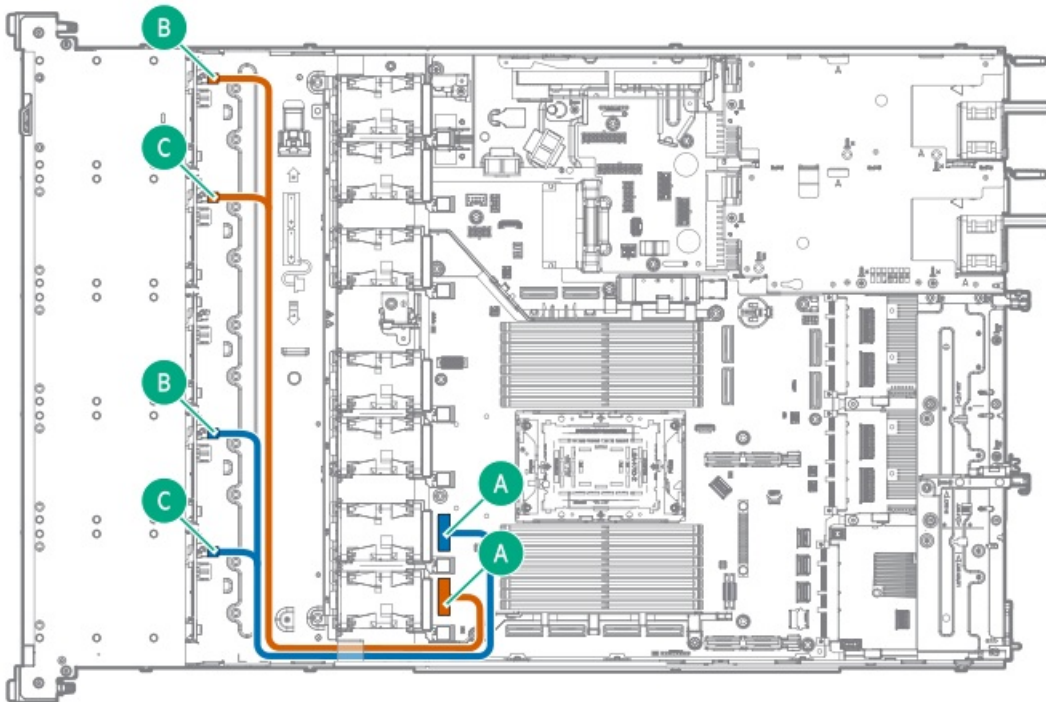

Cable part number	Color	From	To
P75908-001	Orange	2 SFF drive backplane in box 1 and 2	M-XIO port 0
	Blue	2 SFF drive backplane in box 4 and 5	M-XIO port 2

8 SFF drive: Type-p controller cabling

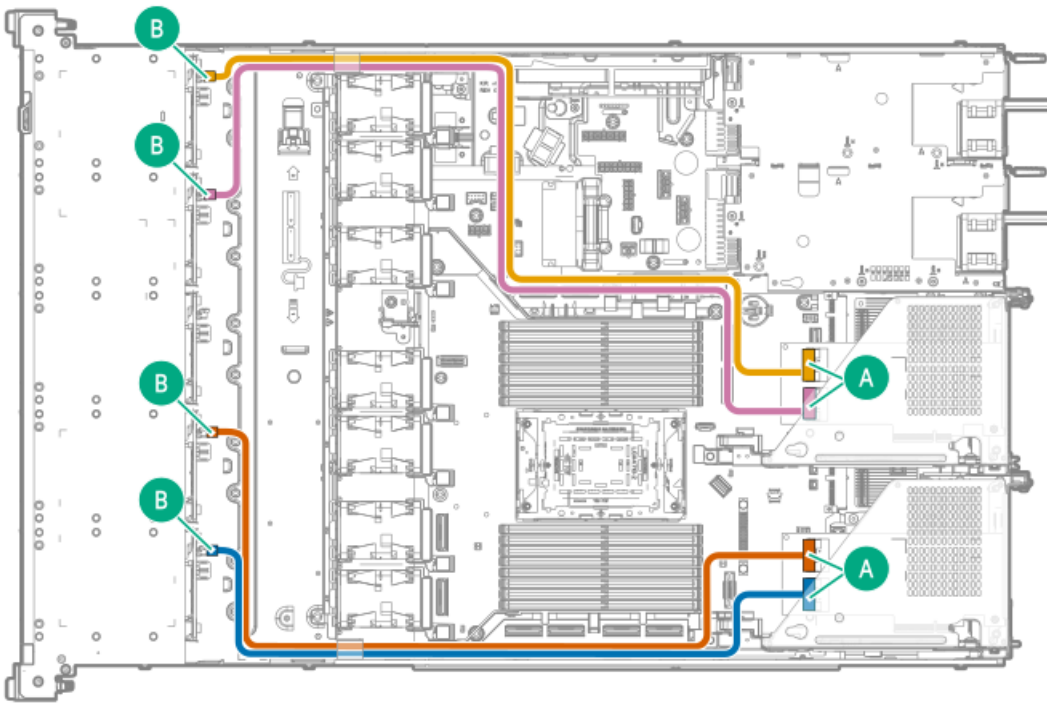

Cable part number	Color	From	To
P75590-001	Orange	2 SFF drive backplane in box 4	Primary type-p controller port 1
	Blue	2 SFF drive backplane in box 5	Primary type-p controller port 2
	Gold	2 SFF drive backplane in box 1	Secondary type-p controller port 1
	Pink	2 SFF drive backplane in box 2	Secondary type-p controller port 2

8 + 2 SFF drive: Direct attached cabling

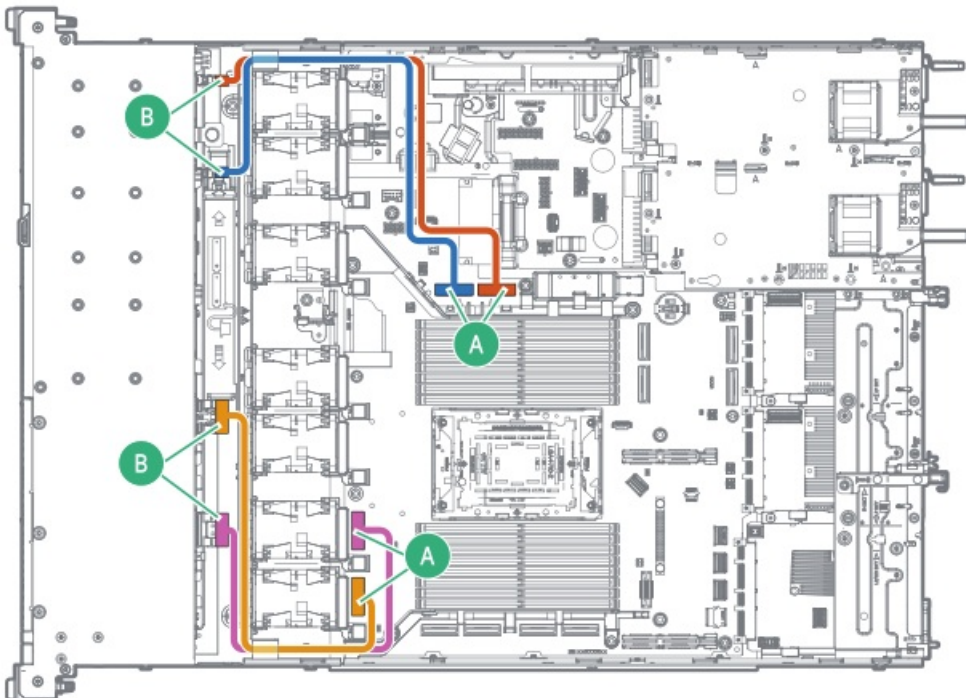

Cable part number	Color	From	To
P71912-001	Orange	Port 4	M-XIO port 4
	Blue	Port 3	M-XIO port 6
P71910-001	Gold	Port 2	M-XIO port 0
	Pink	Port 1	M-XIO port 2

8 + 2 SFF drive: Primary type-p controller cabling

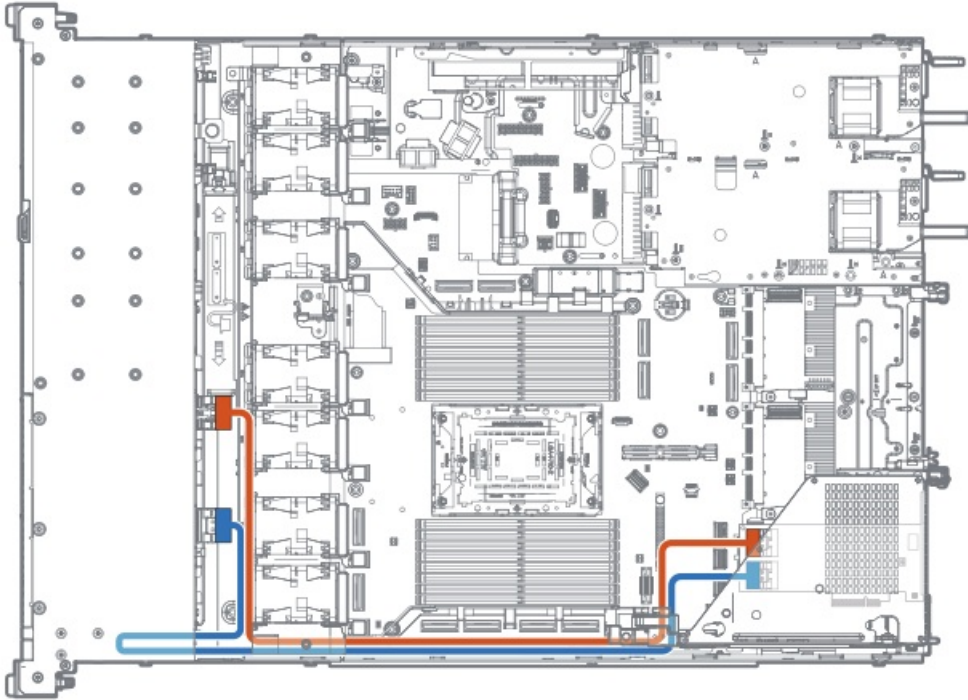

Cable part number	Color	From	To
P45611-001	Orange	8 SFF drive backplane	Type-p controller port 1
P53972-001	Blue	2 SFF drive backplane	Type-p controller port 2

8 + 2 SFF drive: Secondary riser connector cabling

Full-height riser cage blanks are required for this connection.

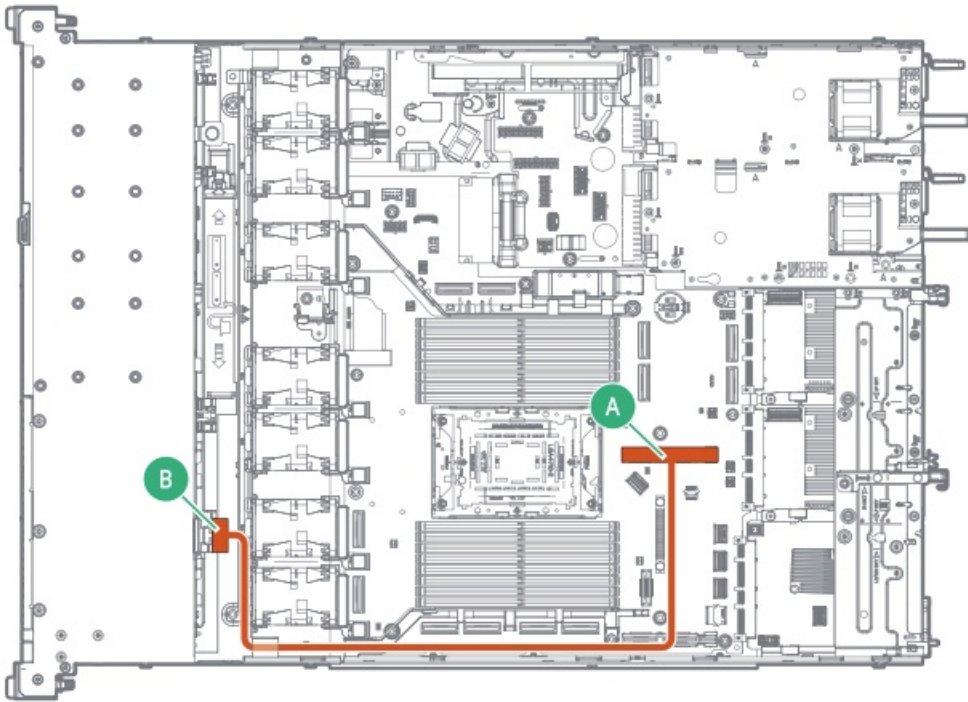

Cable part number	Color	From	To
P74810-001	Orange	2 SFF backplane	Secondary riser connector

8 + 2 SFF drive: Type-o controller cabling

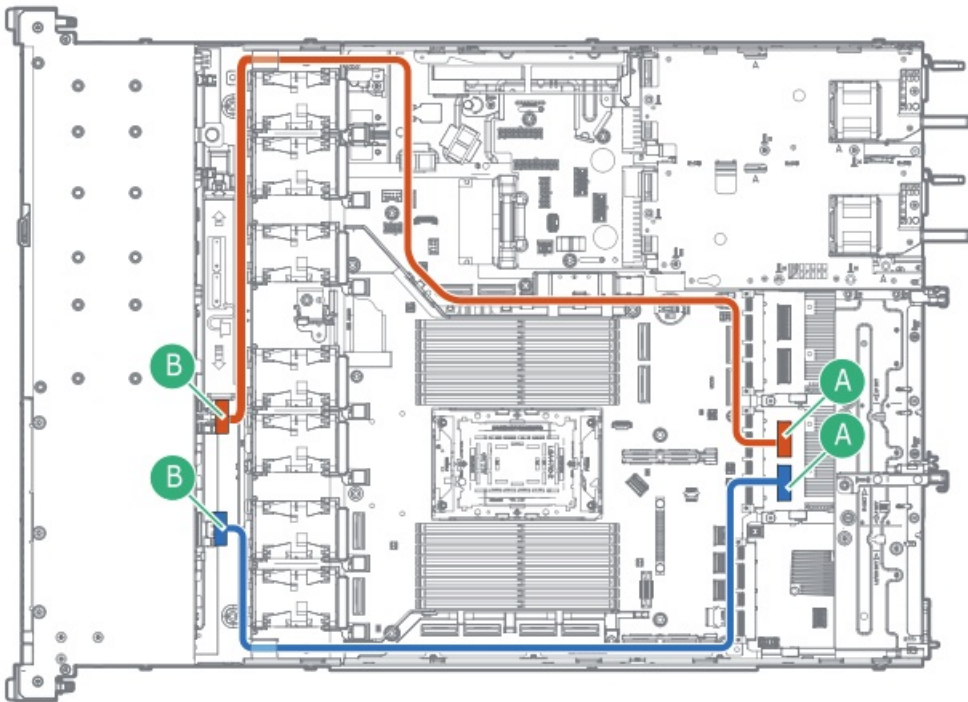

Cable part number	Color	From	To
P48961-001	Orange	8 SFF drive backplane port 1	Type-o controller port 2 in OCP A
P48960-001	Blue	2 SFF drive backplane port 1	Type-o controller port 1 in OCP A

LFF drive controller cabling

4 LFF drive: Type-o controller cabling

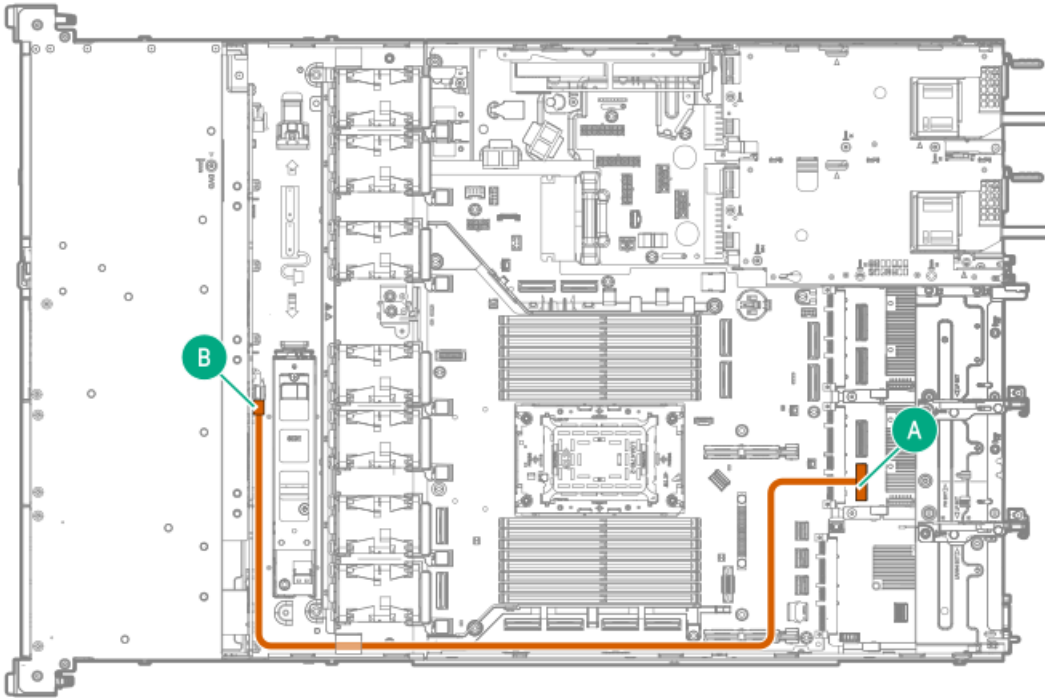

Cable part number	Color	From	To
P53989-001	Orange	4 LFF drive backplane port 1	Type-o controller port 1 in OCP A

4 LFF drive: Primary type-p controller cabling

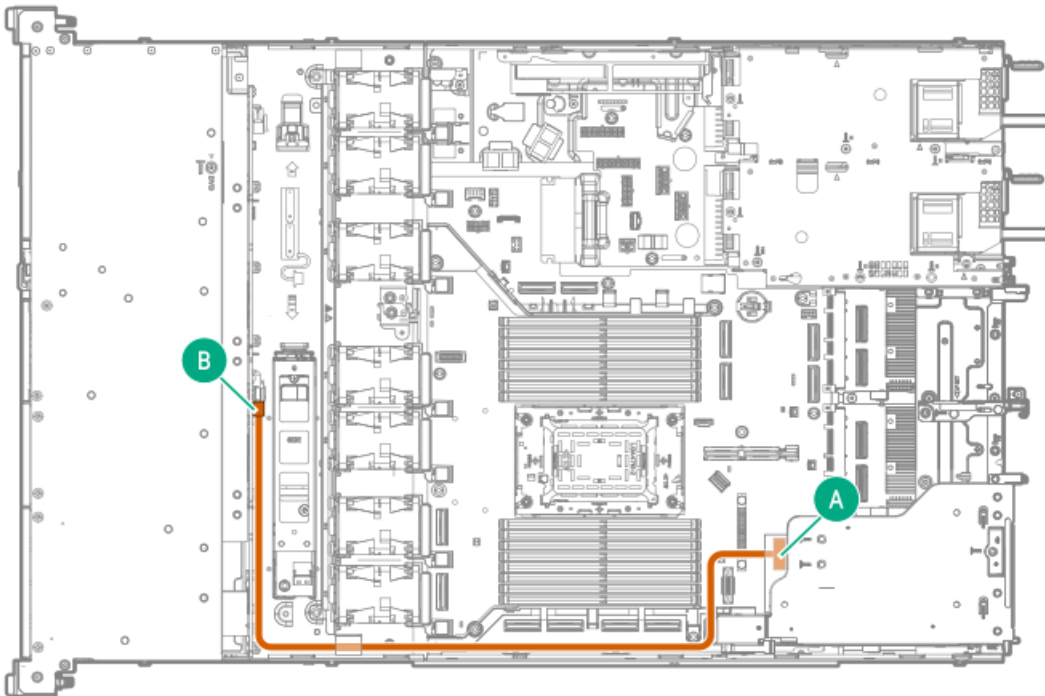

Cable part number	Color	From	To
P54931-001	Orange	4 LFF drive backplane port 1	Type-p controller port 1

12 LFF drive: Primary type-p controller cabling

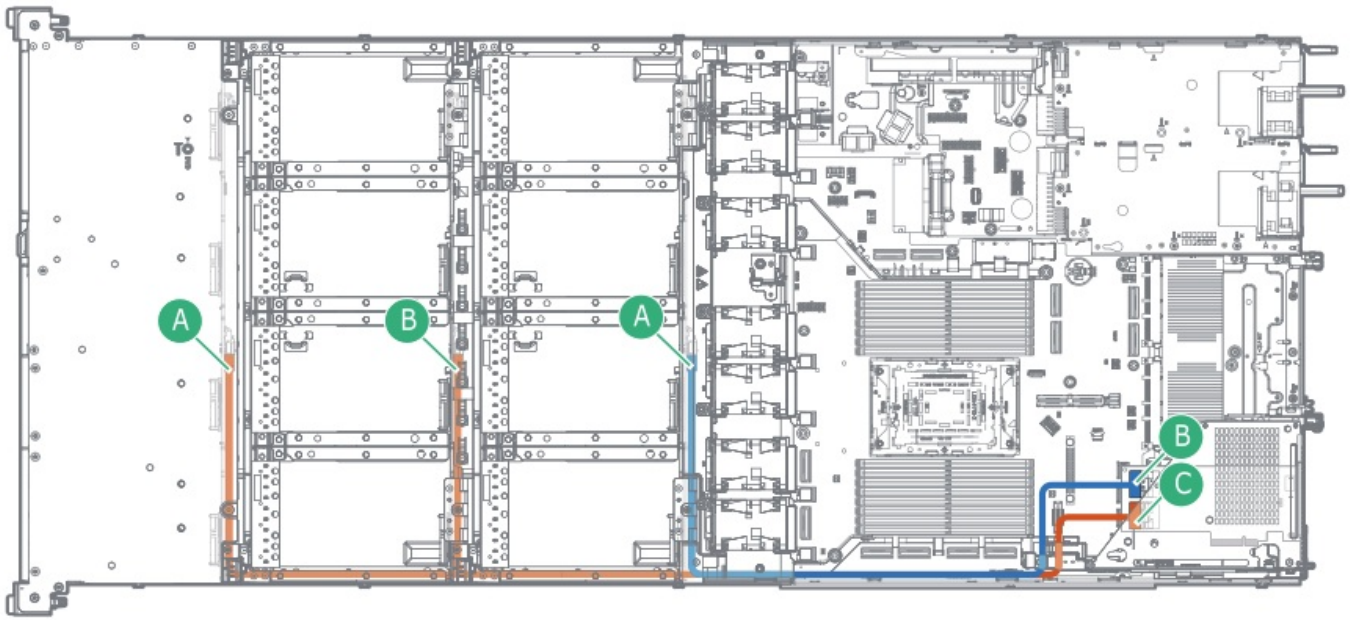

Cable part number	Color	From	To
P54930-001	Orange	4 LFF drive backplane port 1 in box 1 and box 3	Type-p controller port 2
P54931-001	Blue	4 LFF drive backplane port 1 in box 5	Type-p controller port 1

12 LFF drive: Type-o controller cabling

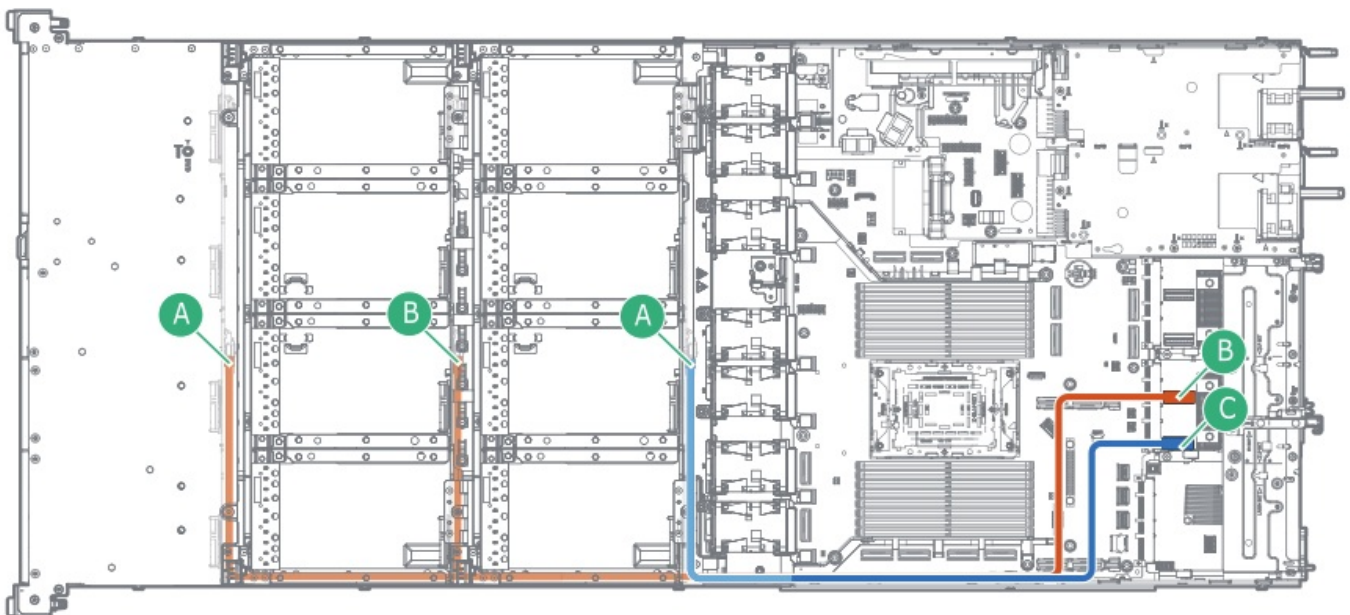

Cable part number	Color	From	To
P54928-001	Orange	4 LFF drive backplane port 1 in box 1 and box 3	Type-o controller port 2 in OCP A
P53989-001	Blue	4 LFF drive backplane port 1 in box 5	Type-o controller port 1 in OCP A

E3.S drive controller cabling

8 E3.S drive: Direct-attached cabling

- Box 1 and 4:

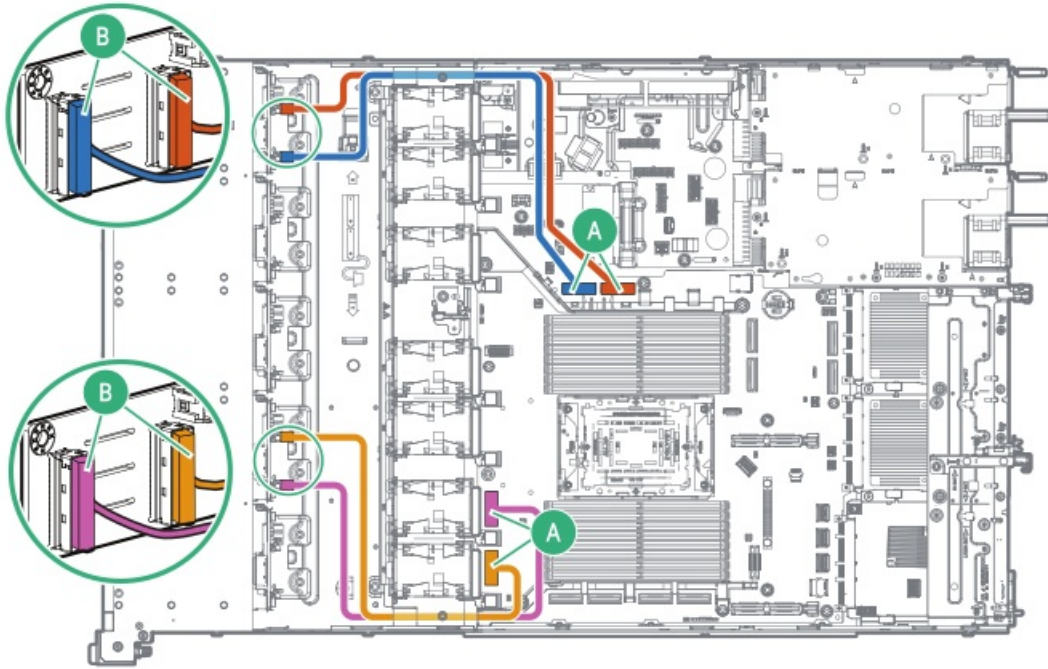

Cable part number	Color	From	To
P75592-001	Orange	Box 1 port 1	M-XIO port 4
	Blue	Box 1 port 2	M-XIO port 6
	Gold	Box 4 port 1	M-XIO port 0
	Pink	Box 4 port 2	M-XIO port 2

- Box 1 and 3:

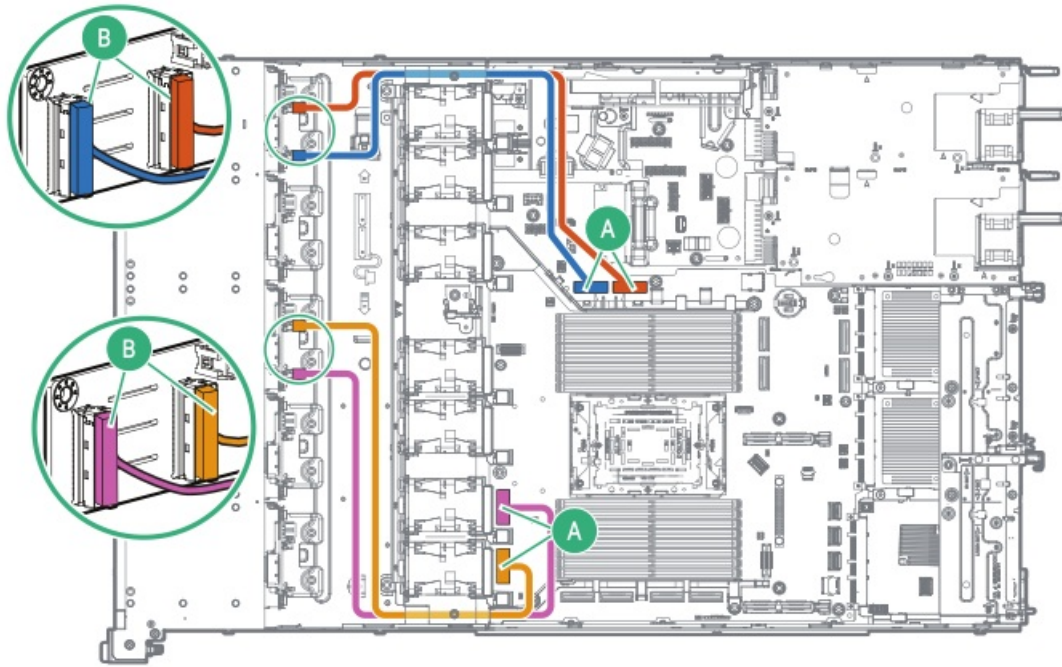

Cable part number	Color	From	To
P75592-001	Orange	Box 1 port 1	M-XIO port 4
	Blue	Box 1 port 2	M-XIO port 6
	Gold	Box 3 port 1	M-XIO port 0
	Pink	Box 3 port 2	M-XIO port 2

8 E3.S drive: Primary and secondary riser connector cabling

Full-height riser cage blanks are required for this connection.

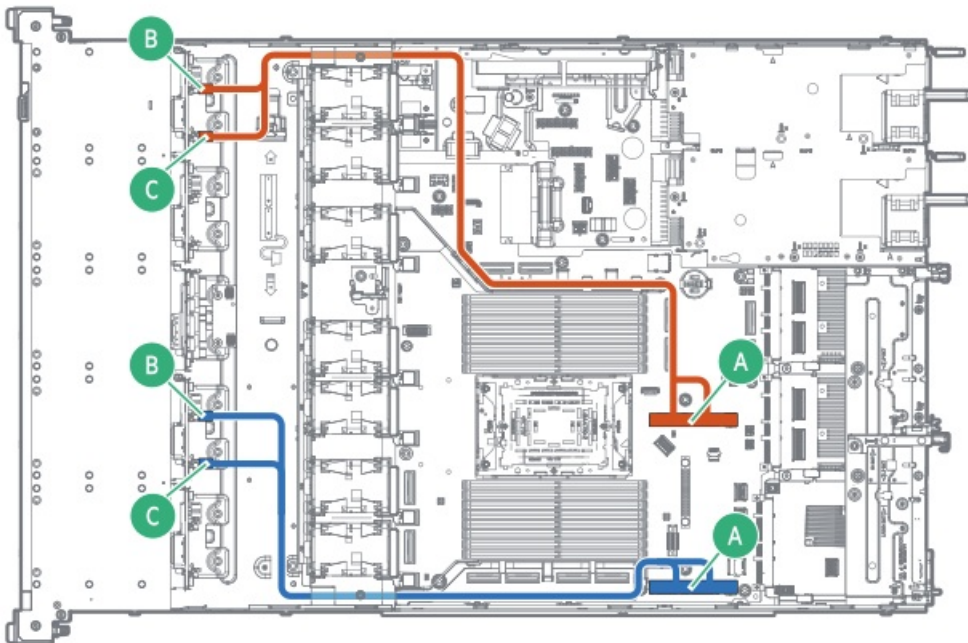

Cable part number	Color	From	To
P75580-001	Orange	Box 1 port 1 and 2	Secondary riser connector
P75577-001	Blue	Box 4 port 1 and 2	Primary riser connector

12 E3.S drive: MR932i-p controller cabling in the primary and secondary riser

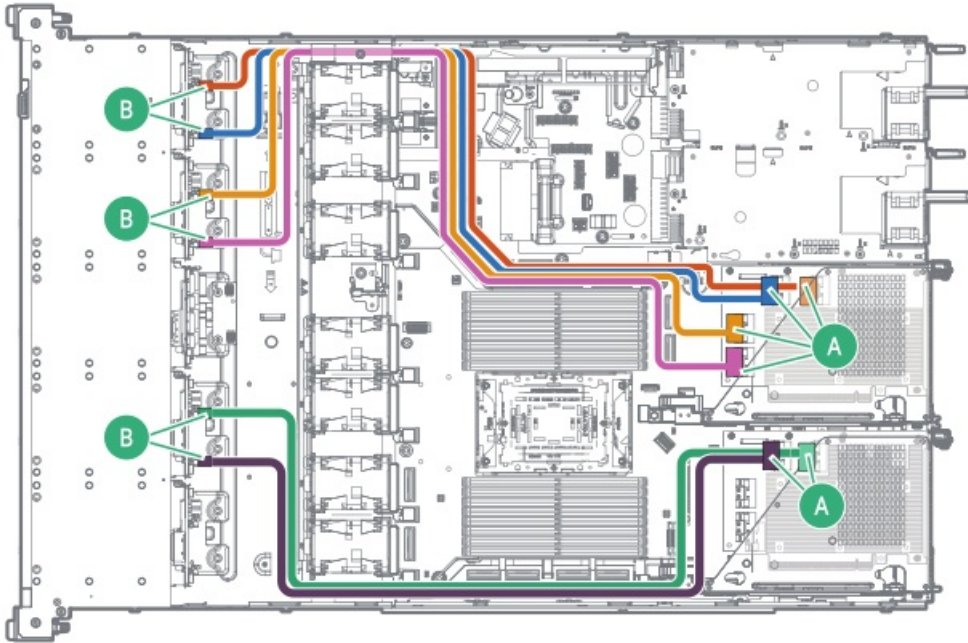

Cable part number	Color	From	To
P75318-001	Orange	Box 1 port 2	Secondary type-p controller port 1
	Blue	Box 1 port 1	Secondary type-p controller port 2
	Gold	Box 2 port 2	Secondary type-p controller port 3
	Pink	Box 2 port 1	Secondary type-p controller port 4
	Green	Box 4 port 1	Primary type-p controller port 1
	Purple	Box 4 port 2	Primary type-p controller port 2

16 E3.S drive: Primary and secondary riser connector cabling

Full-height riser cage blanks are required for these connections.

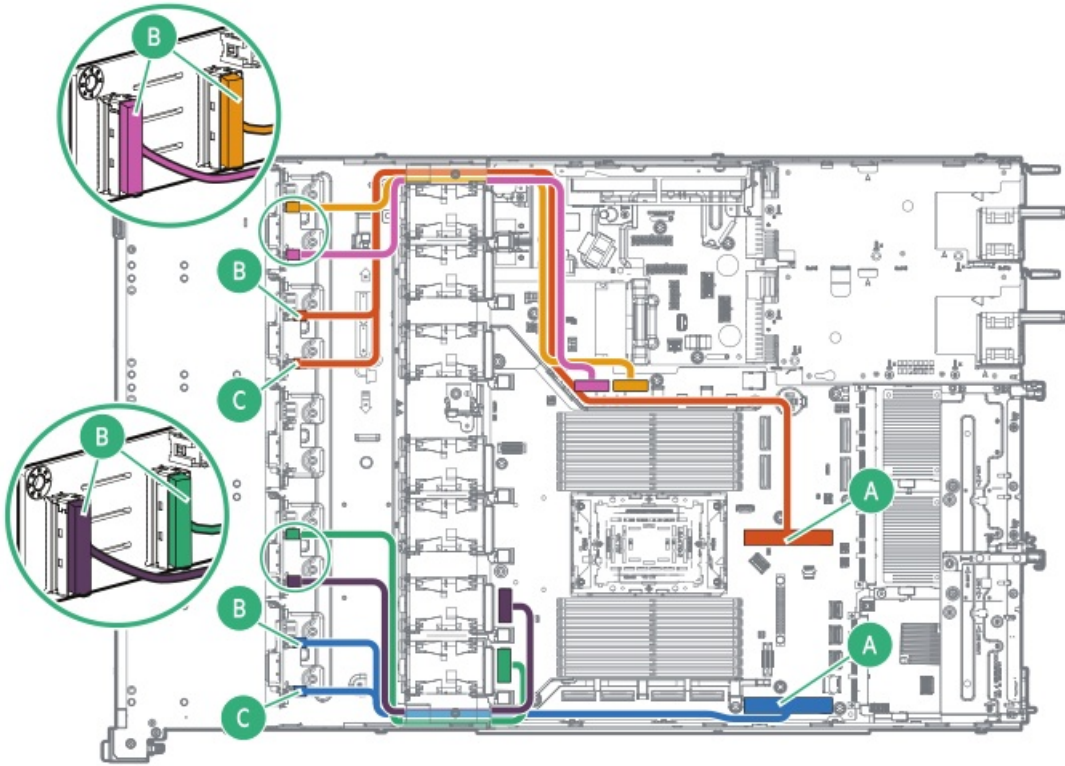

Cable part number	Color	From	To
P75580-001	Orange	Box 2 port 1 and 2	Secondary riser connector
P75577-001	Blue	Box 5 port 1 and 2	Primary riser connector
P75592-001	Gold	Box 1 port 1	M-XIO port 4
	Pink	Box 1 port 2	M-XIO port 6
	Green	Box 4 port 1	M-XIO port 2
	Purple	Box 4 port 2	M-XIO port 0

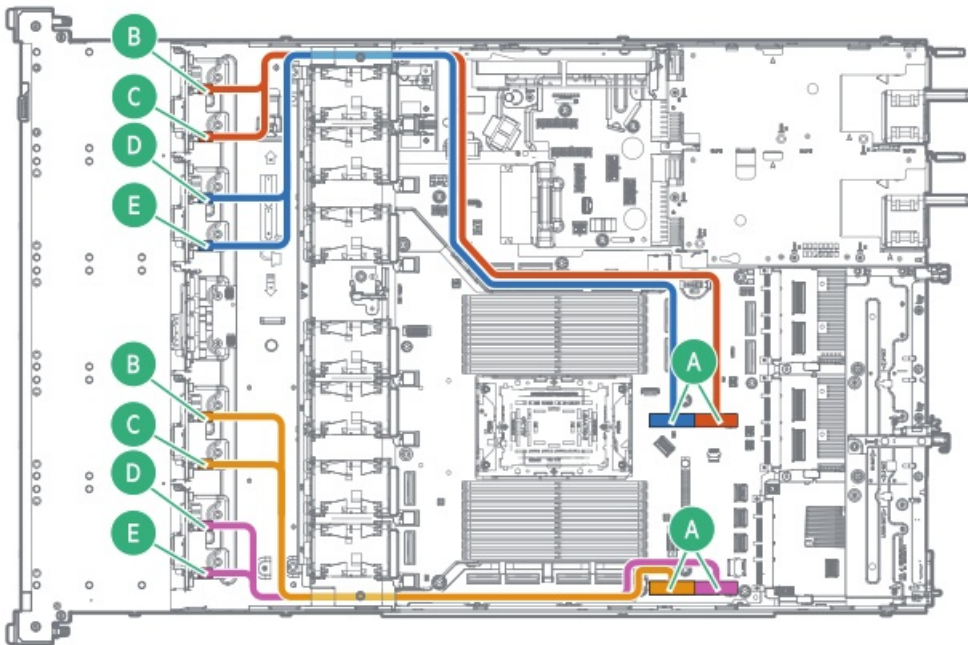

Cable part number	Color	From	To
P75578-001	Orange	Box 1 port 1 and 2	Secondary riser connector
	Blue	Box 2 port 1 and 2	
P75579-001	Gold	Box 4 port 1 and 2	Primary riser connector
	Pink	Box 5 port 1 and 2	

4/16 E3.S drive: Primary type-p controller cabling

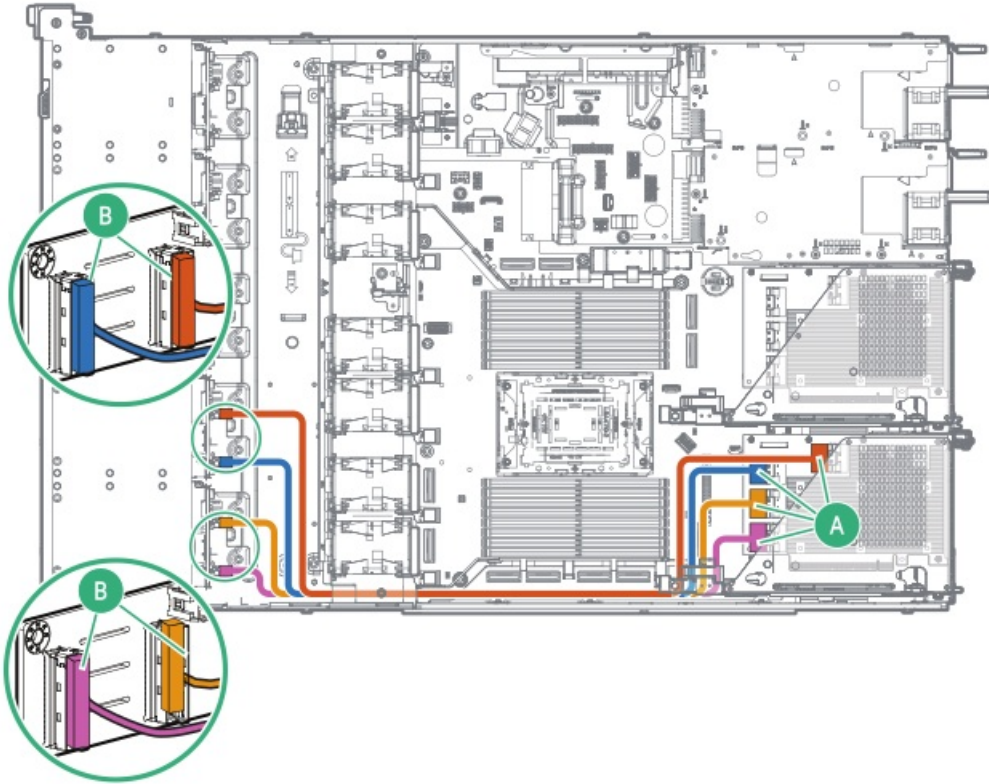

Cable part number	Color	From	To
P75590-001	Orange	Box 4 port 1	Type-p controller port 4
	Blue	Box 4 port 2	Type-p controller port 3
	Gold	Box 5 port 1	Type-p controller port 2
	Pink	Box 5 port 2	Type-p controller port 1

4/16 E3.S drive: MR932i-p controller cabling

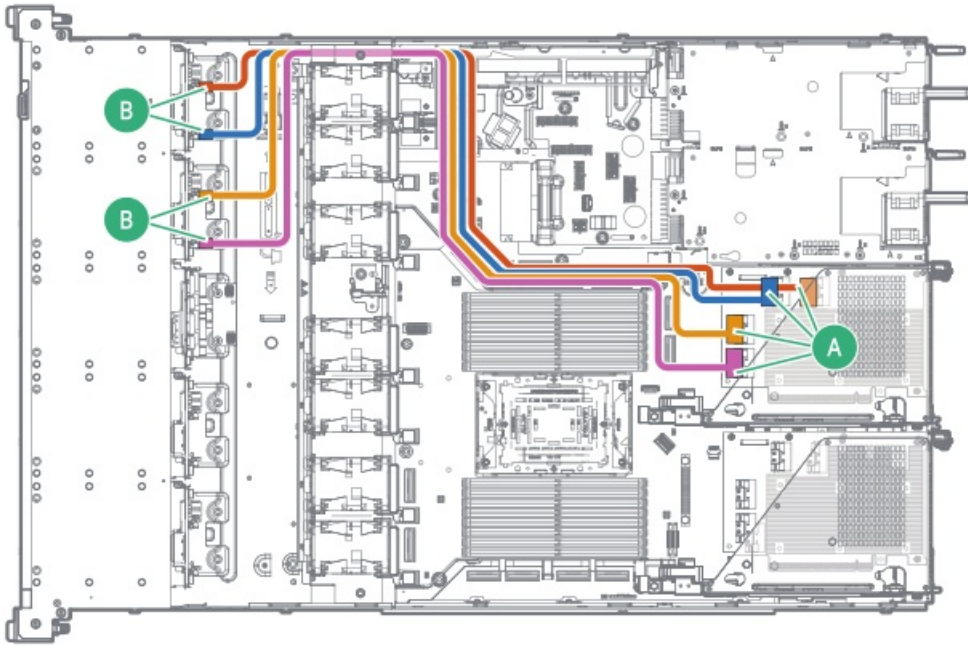

Cable part number	Color	From	To
P75318-001	Orange	Box 1 port 1	Port 1
	Blue	Box 1 port 2	Port 2
	Gold	Box 2 port 1	Port 3
	Pink	Box 2 port 2	Port 4

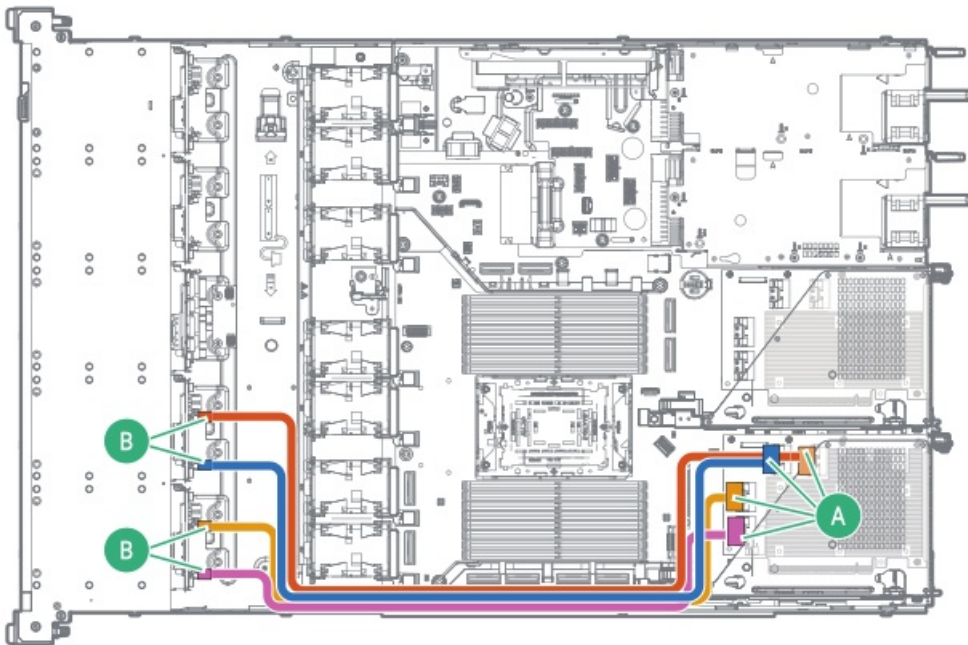

Cable part number	Color	From	To
P75570-001	Orange	Box 4 port 2	Port 1
	Blue	Box 4 port 1	Port 2
	Gold	Box 5 port 2	Port 3
	Pink	Box 5 port 1	Port 4

4/16 E3.S drive: Secondary type-p controller cabling

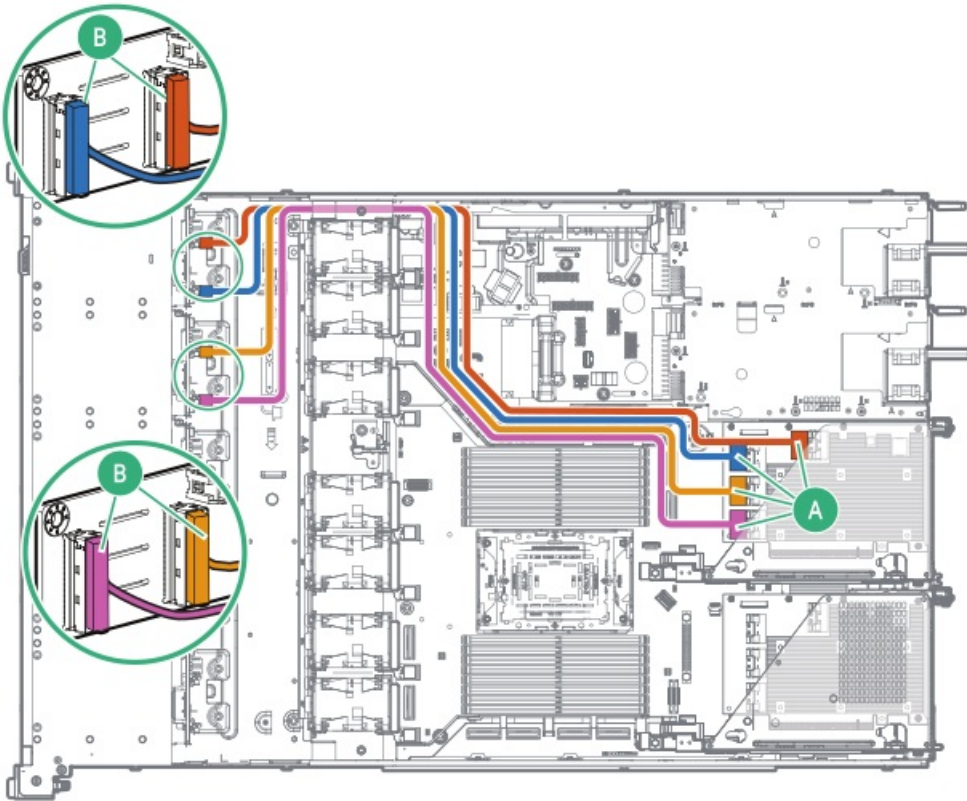

Cable part number	Color	From	To
P75590-001	Orange	Box 1 port 1	Port 1
	Blue	Box 1 port 2	Port 2
	Gold	Box 2 port 1	Port 3
	Pink	Box 2 port 2	Port 4

16 E3.S drive: MR932i-p controller cabling

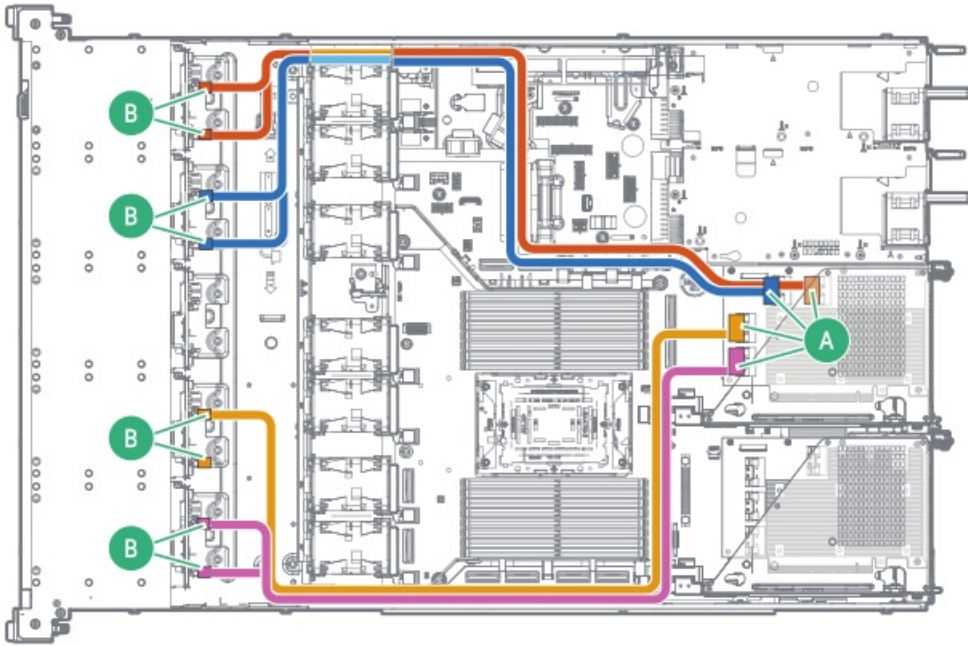

Cable part number	Color	From	To
P75581-001	Orange	Box 1 port 1	Port 1
		Box 1 port 2	
	Blue	Box 2 port 1	Port 2
		Box 2 port 2	
	Gold	Box 4 port 1	Port 3
		Box 4 port 2	
	Pink	Box 5 port 1	Port 4
		Box 5 port 2	

20 E3.S drive: Direct-attached cabling

- Box 1-3:



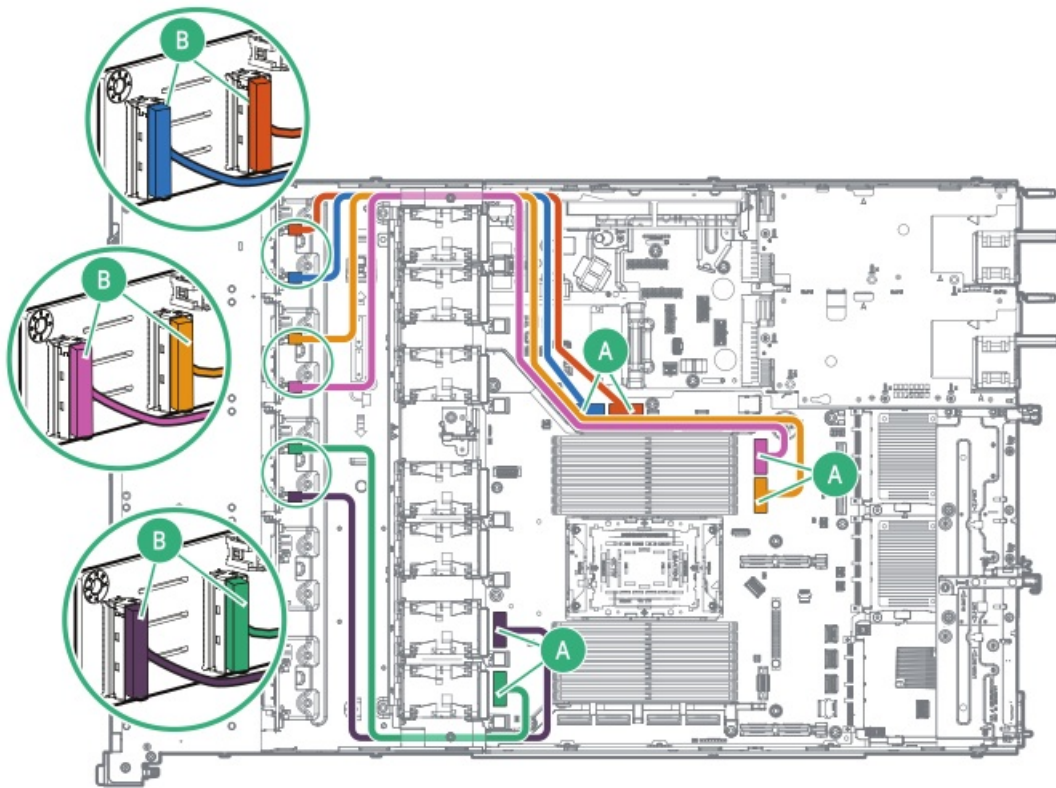

Cable part number	Color	From	To
P75592-001	Orange	Box 1 port 1	M-XIO port 4
	Blue	Box 1 port 2	M-XIO port 6
P75576-001	Gold	Box 2 port 1	M-XIO port 13
	Pink	Box 2 port 2	M-XIO port 17
P75504-001	Green	Box 3 port 1	M-XIO port 0
	Purple	Box 3 port 2	M-XIO port 2

- Box 4-5:



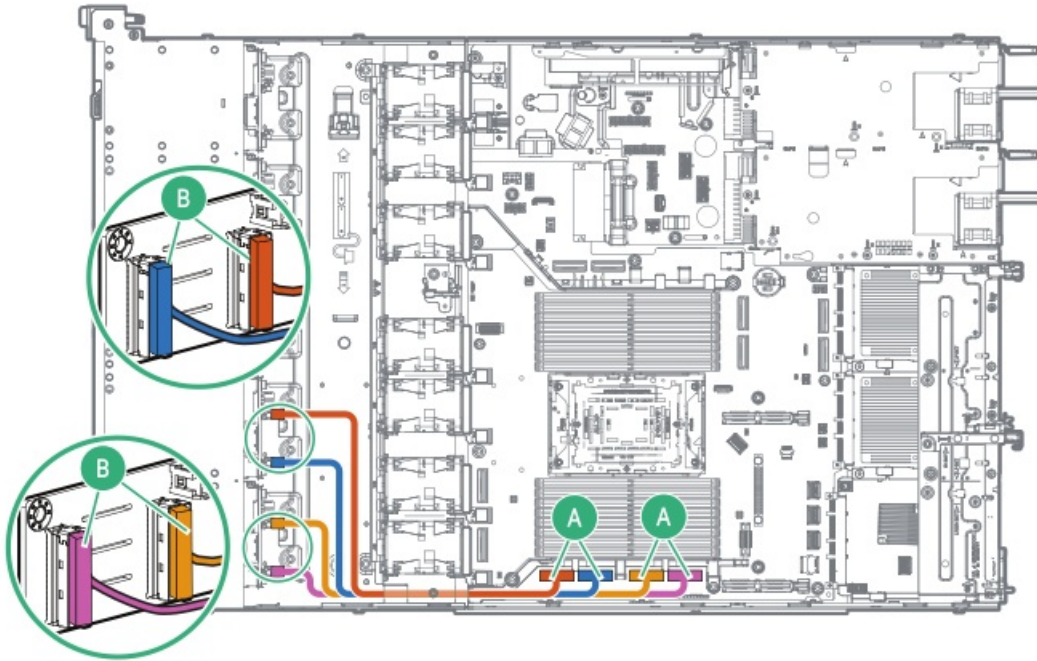

Cable part number	Color	From	To
P75505-001	Orange	Box 4 port 1	M-XIO port 7
	Blue	Box 4 port 2	M-XIO port 5
	Gold	Box 5 port 1	M-XIO port 1
	Pink	Box 5 port 2	M-XIO port 3

20 E3.S drive: MR932i-p controller cabling

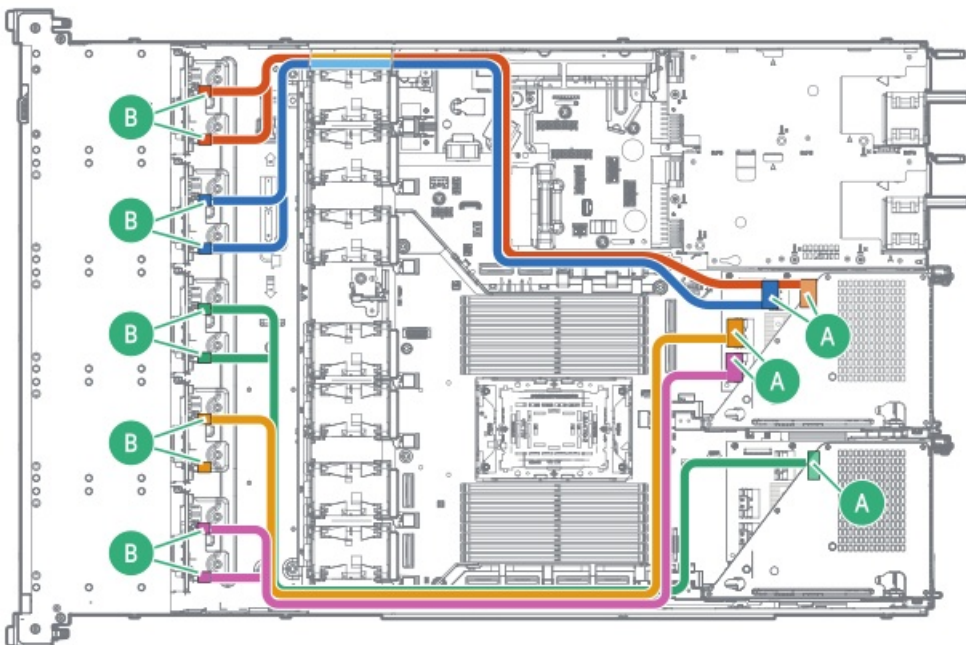

Cable part number	Color	From	To
P75581-001	Orange	Box 1 port 1	Primary type-p controller port 1
		Box 1 port 2	
	Blue	Box 2 port 1	Primary type-p controller port 2
		Box 2 port 2	
	Green	Box 3 port 1	Secondary type-p controller port 1
		Box 3 port 2	
	Gold	Box 4 port 1	Primary type-p controller port 3
		Box 4 port 2	
	Pink	Box 5 port 1	Primary type-p controller port 4
		Box 5 port 2	

20 E3.S drive: Type-p controller cabling

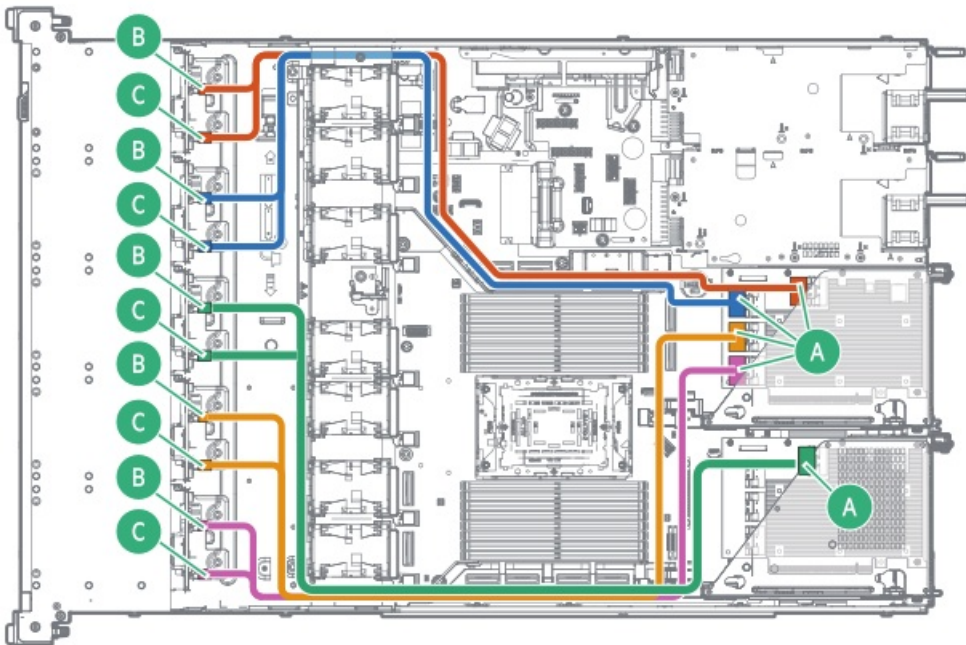

Cable part number	Color	From	To
P75593-001	Orange	Box 1 port 1 and 2	Primary type-p controller port 1
	Blue	Box 2 port 1 and 2	
	Green	Box 3 port 1 and 2	Secondary type-p controller port 1
	Gold	Box 4 port 1 and 2	Primary type-p controller port 3
	Pink	Box 5 port 1 and 2	Primary type-p controller port 4

Mixed drive controller cabling

8 SFF drive: Type-o controller cabling

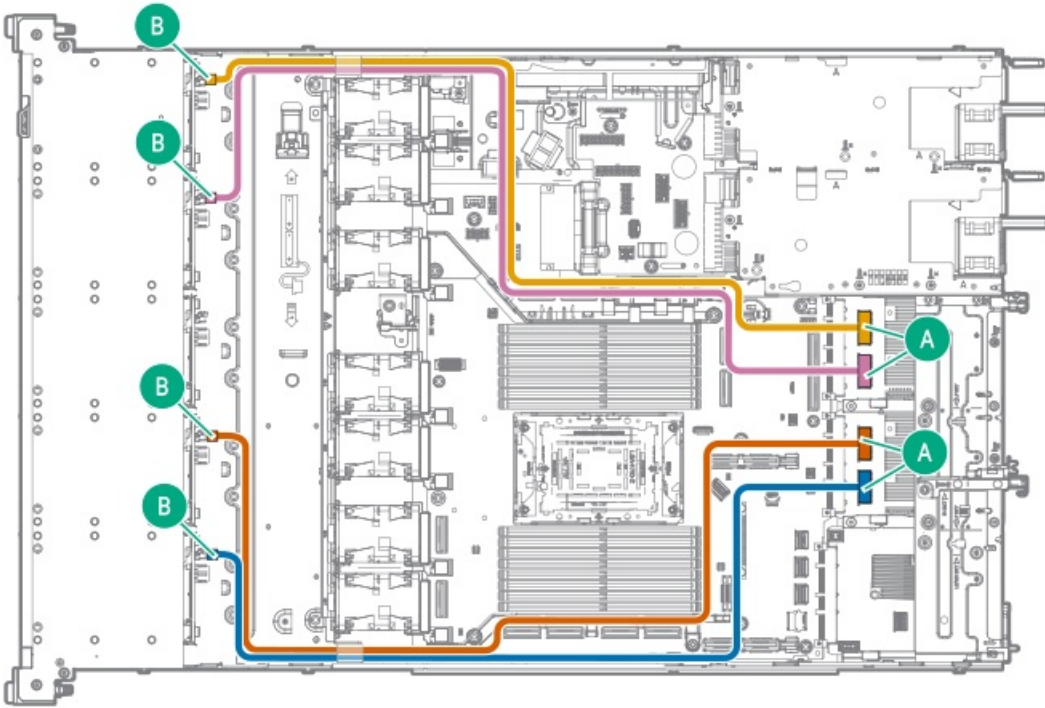

Cable part number	Color	From	To
P75589-001	Orange	2 SFF drive backplane in box 4	Type-o controller port 2 in OCP A
	Blue	2 SFF drive backplane in box 5	Type-o controller port 1 in OCP A
	Gold	2 SFF drive backplane in box 1	Type-o controller port 2 in OCP B
	Pink	2 SFF drive backplane in box 2	Type-o controller port 1 in OCP B

8 SFF + 4 E3.S drive: Onboard SAS/SATA/NVMe cabling

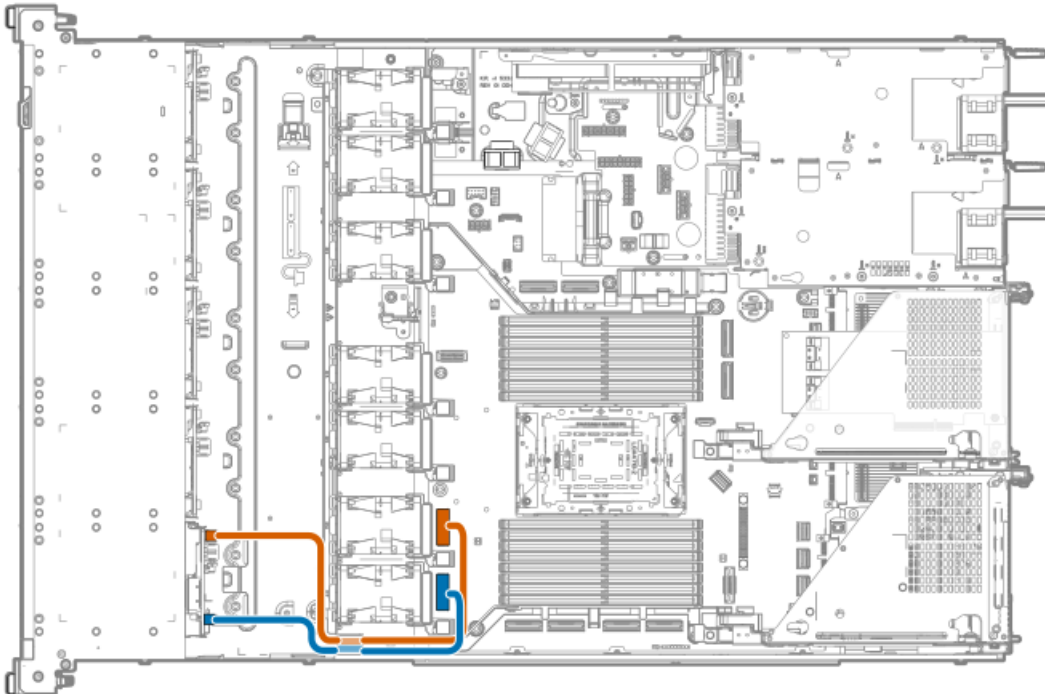

Cable part number	Color	From	To
P75594-001	Orange	4 E3.S drive backplane port 2 in box 5	
	Blue	4 E3.S drive backplane port 1 in box 5	

8 SFF + 4 E3.S drive: Type-p controller cabling

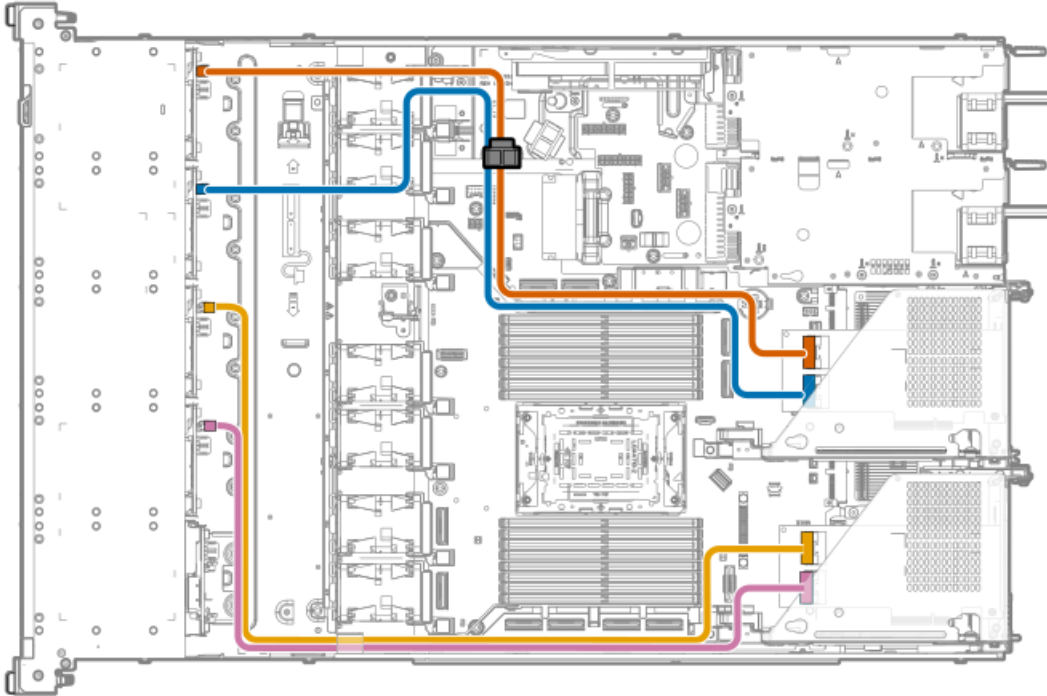

Cable part number	Color	From	To
P75590-001	Orange	2 SFF drive backplane in box 1	Secondary type-p controller port 1
	Blue	2 SFF drive backplane in box 2	Secondary type-p controller port 2
P75590-001	Gold	2 SFF drive backplane in box 3	Primary type-p controller port 1
	Pink	2 SFF drive backplane in box 4	Primary type-p controller port 2

10 SFF drive: Direct attached cabling

Full-height riser cage blanks are required for this connection.

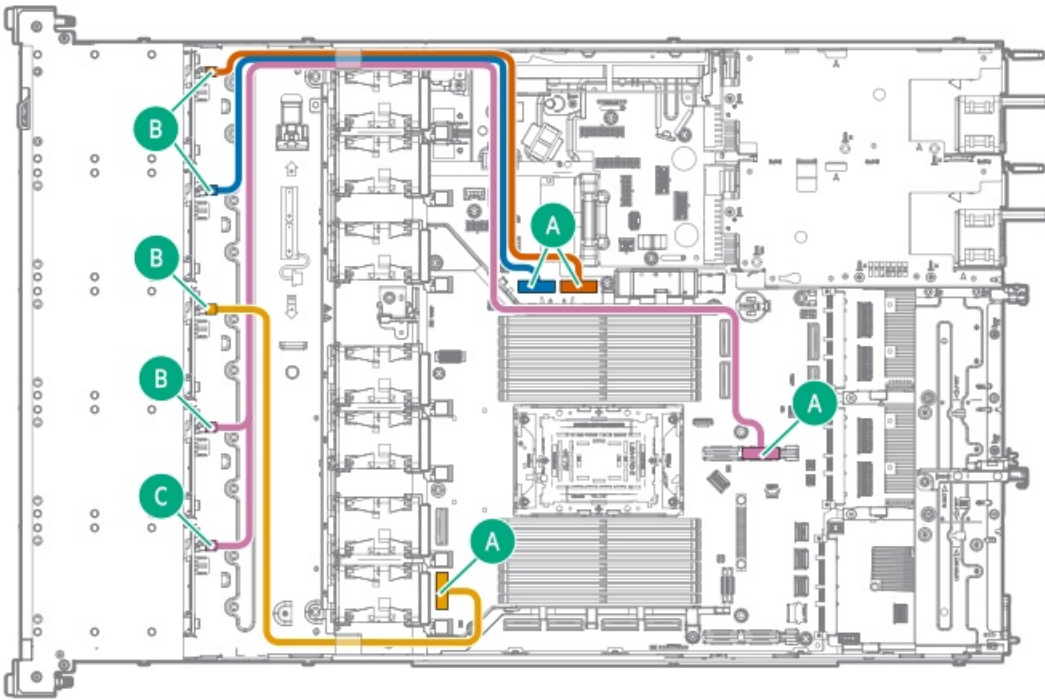

Cable part number	Color	From	To
P75592-001	Orange	2 SFF drive backplane in box 1	M-XIO port 4
	Blue	2 SFF drive backplane in box 2	M-XIO port 6
	Gold	2 SFF drive backplane in box 3	M-XIO port 0
P75580-001	Pink	2 SFF drive backplane in box 4	Secondary riser connector and 5

GPU-optimized configuration drive controller cabling

4 SFF drive: Type-o controller cabling



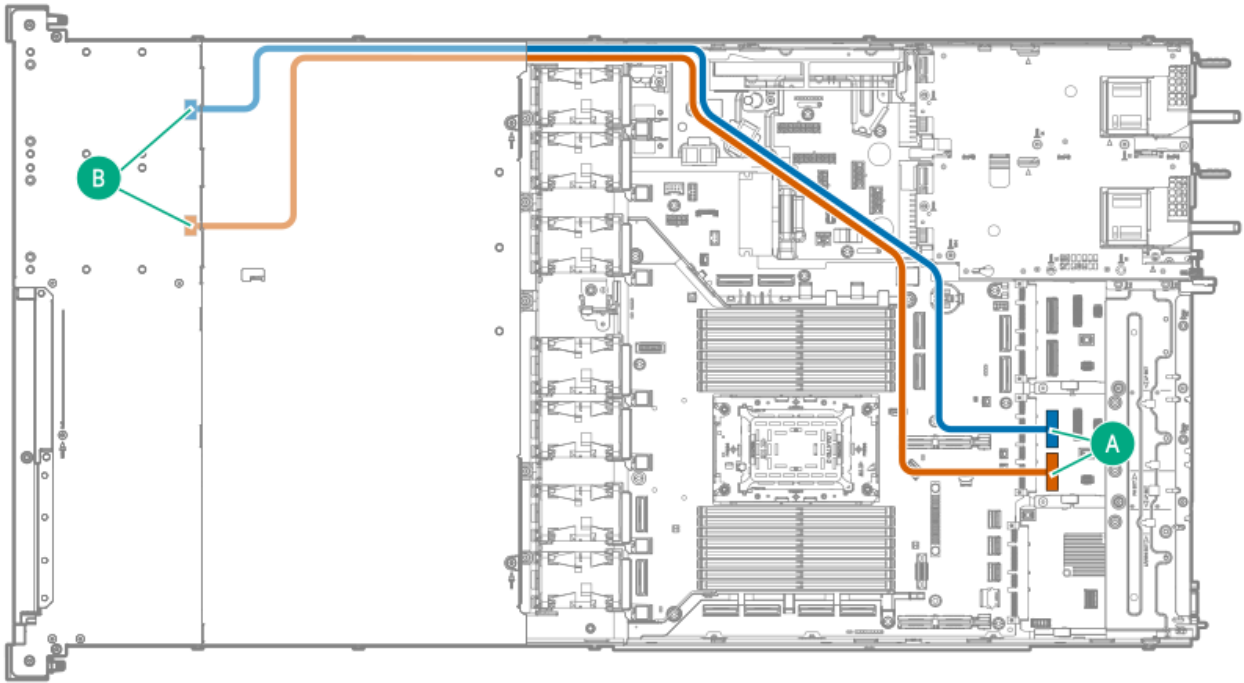

Cable part number	Color	From	To
P75587-001	Orange	Box 2 port 1	Type-o controller port 1 in OCP A
P75589-001	Blue	Box 1 port 1	Type-o controller port 2 in OCP A

4 SFF drive: Primary type-p controller cabling

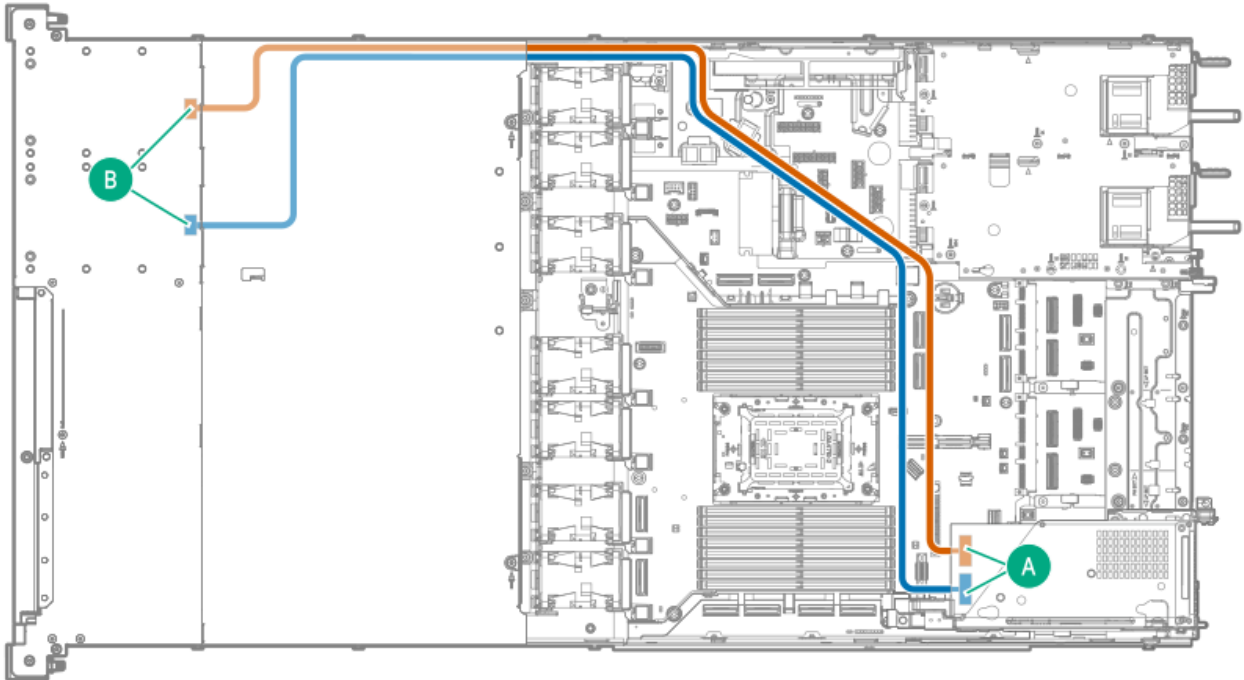

Cable part number	Color	From	To
P75588-001	Orange	2 SFF backplane port 1 in box 1	Type-p controller port 1
	Blue	2 SFF backplane port 1 in box 2	Type-p controller port 2

8 E3.S drive: Primary and secondary riser connector cabling

Full-height riser cage blanks are required for these connections.

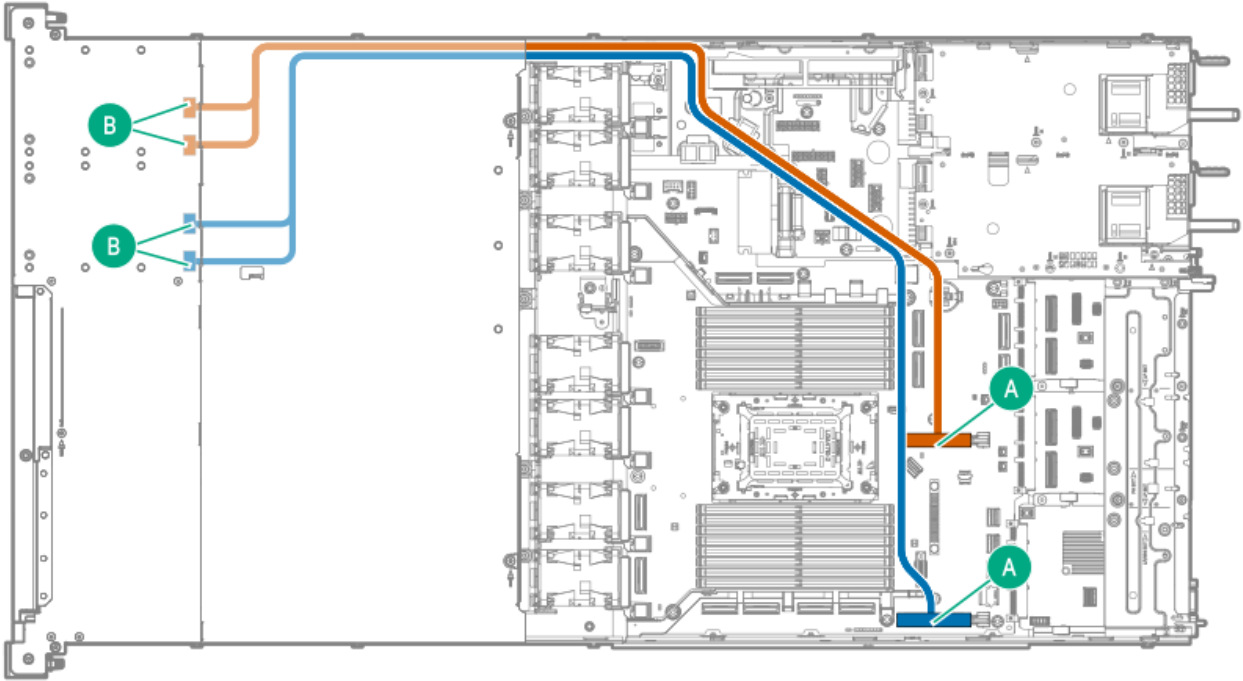

Cable part number	Color	From	To
P75580-001	Orange	Box 1 port 1 and 2	Primary riser connector
	Blue	Box 2 port 1 and 2	Secondary riser connector

8 E3.S drive: Primary riser type-p controller cabling

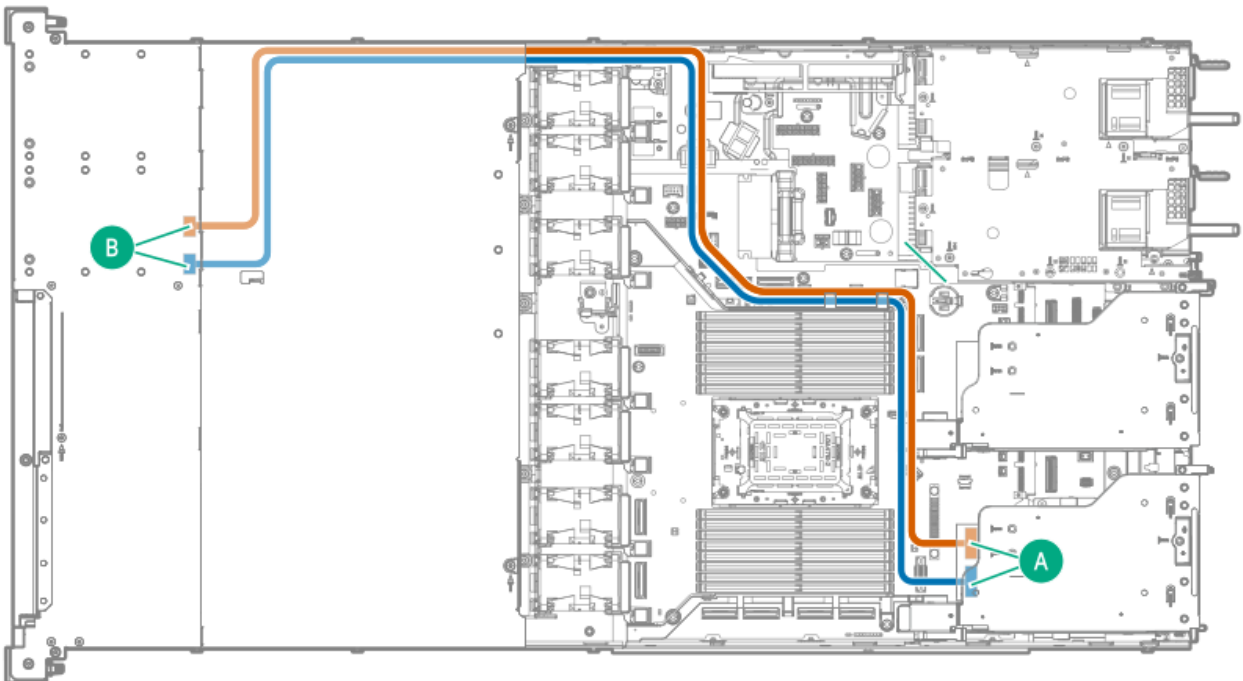

Cable part number	Color	From	To
P75588-001	Orange	Box 2 port 2	Type-p controller port 1
	Blue	Box 2 port 1	Type-p controller port 2

8 E3.S drive: Secondary type-p controller cabling

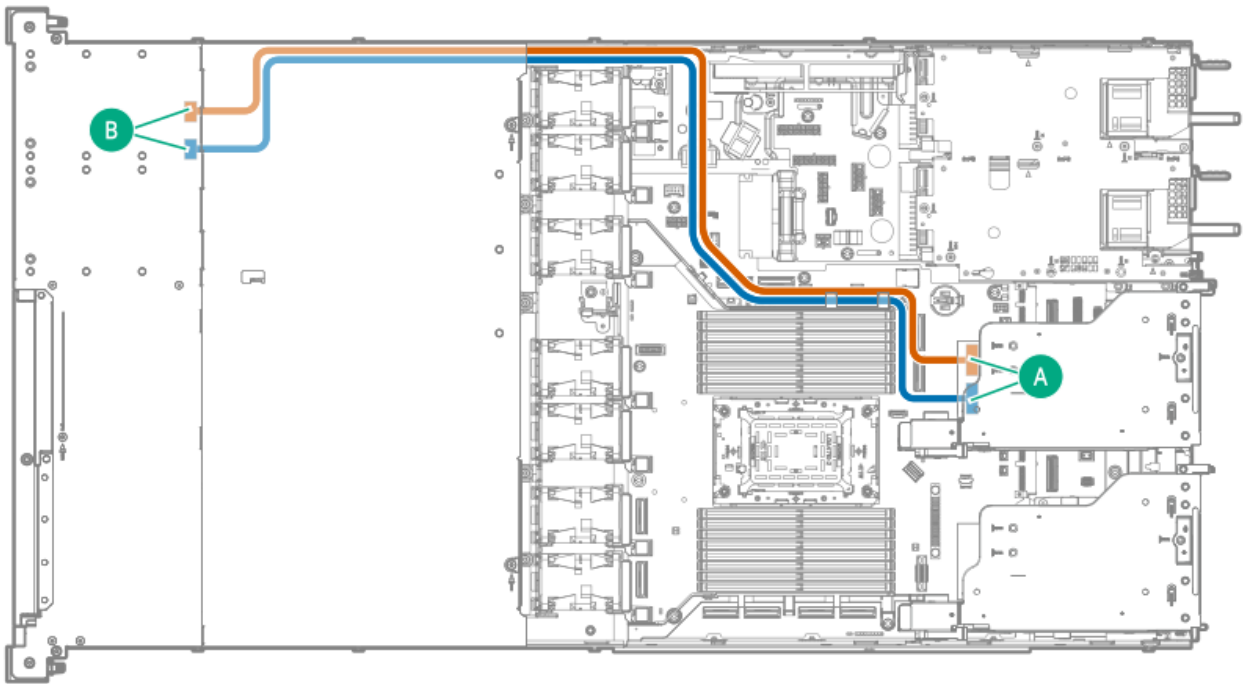

Cable part number	Color	From	To
P75590-001	Orange	Box 1 port 2	Type-p controller port 1
	Blue	Box 1 port 1	Type-p controller port 2

8 E3.S drive: MR932i-p controller cabling

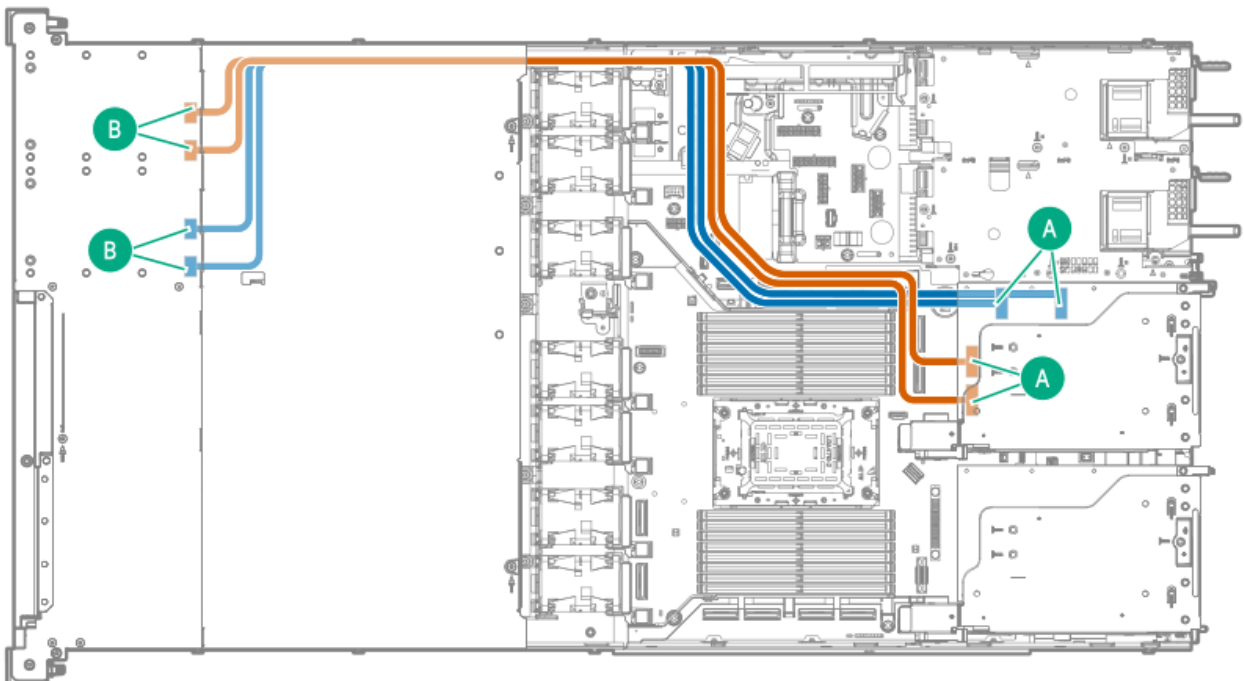

Cable part number	Color	From	To
P75575-001	Orange	Box 1 port 1 and 2	Port 3 and 4
	Blue	Box 2 port 1 and 2	Port 1 and 2

Energy pack cabling

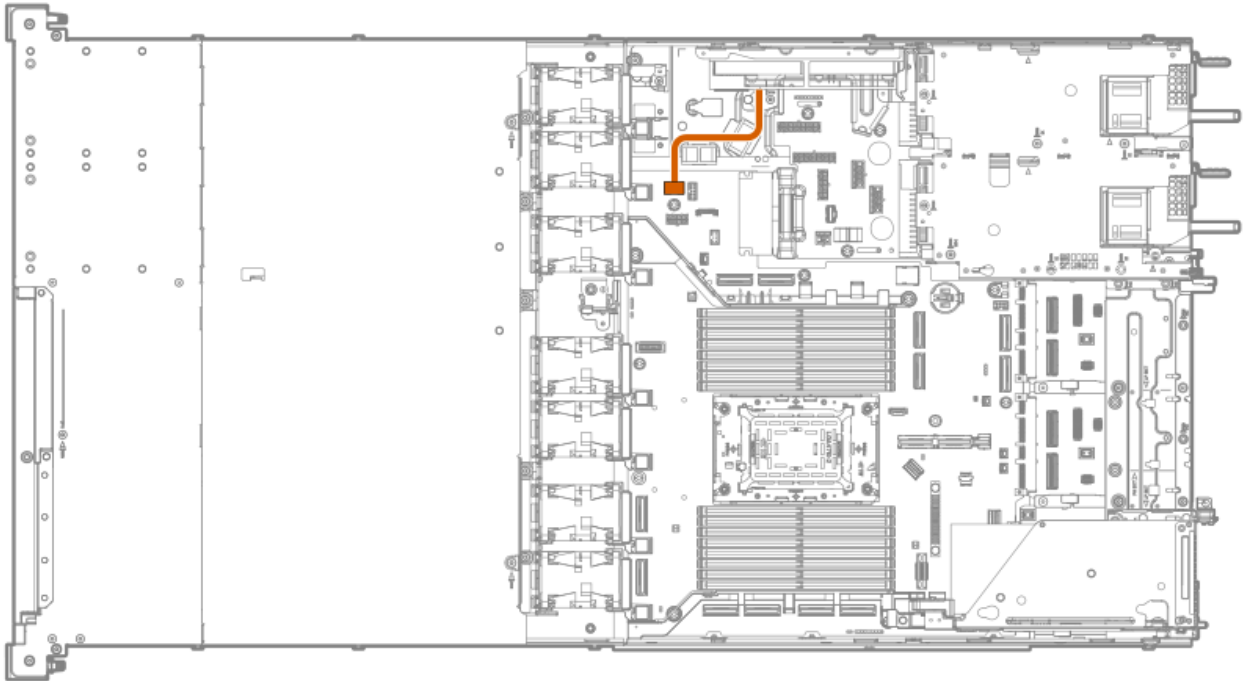

Cable part number	Color	From	To
—	Orange	Energy pack	Energy pack connector

Storage controller backup power cabling

The exact route of the storage controller backup power cabling will depend on:

- The riser slot where the controller is installed
- The location of the storage controller backup power connector on the controller

Use the following diagrams for reference only.

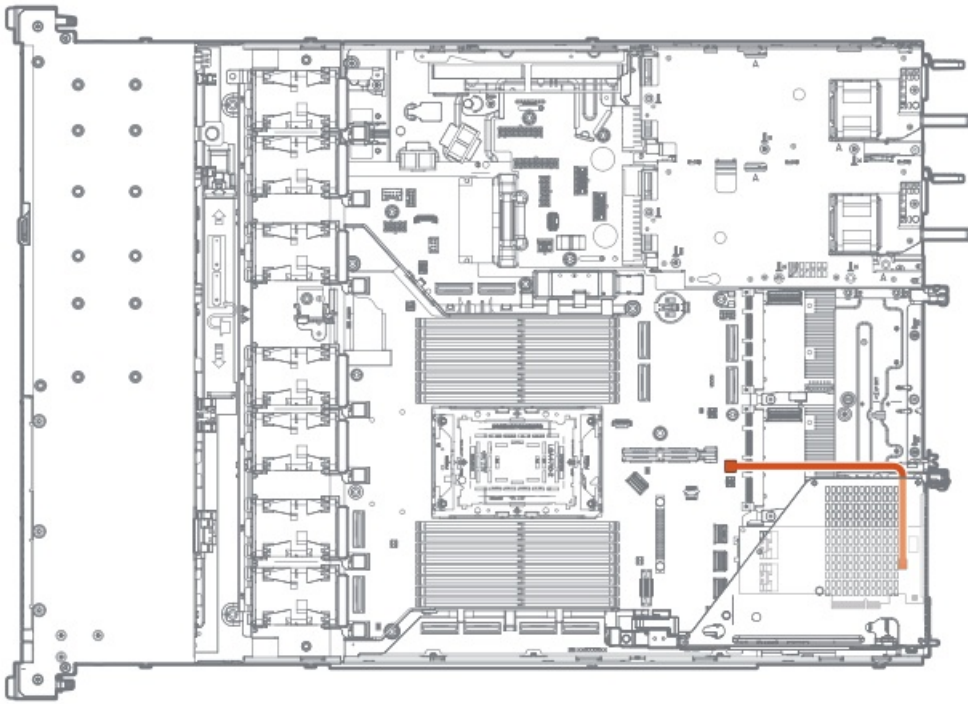

Cable part number	Color	From	To
—	Orange	Primary type-p controller	Storage controller backup power connector

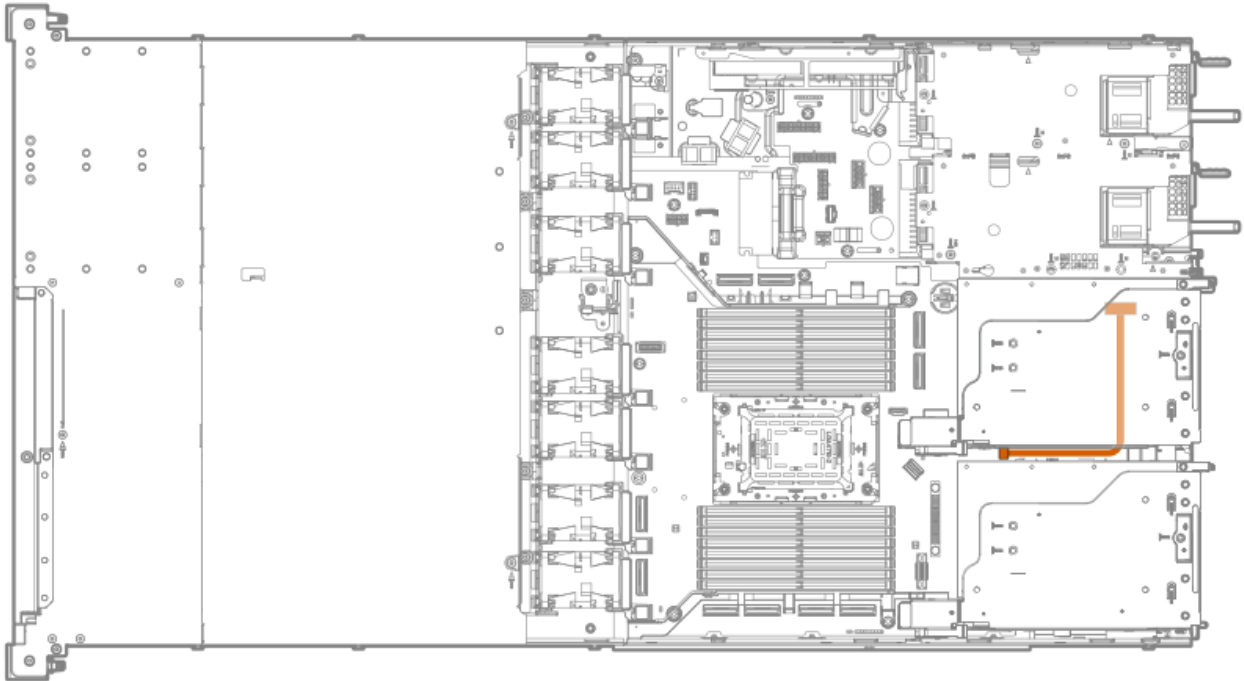

Cable part number	Color	From	To
—	Orange	Secondary type-p controller	Storage controller backup power connector

Fan cabling



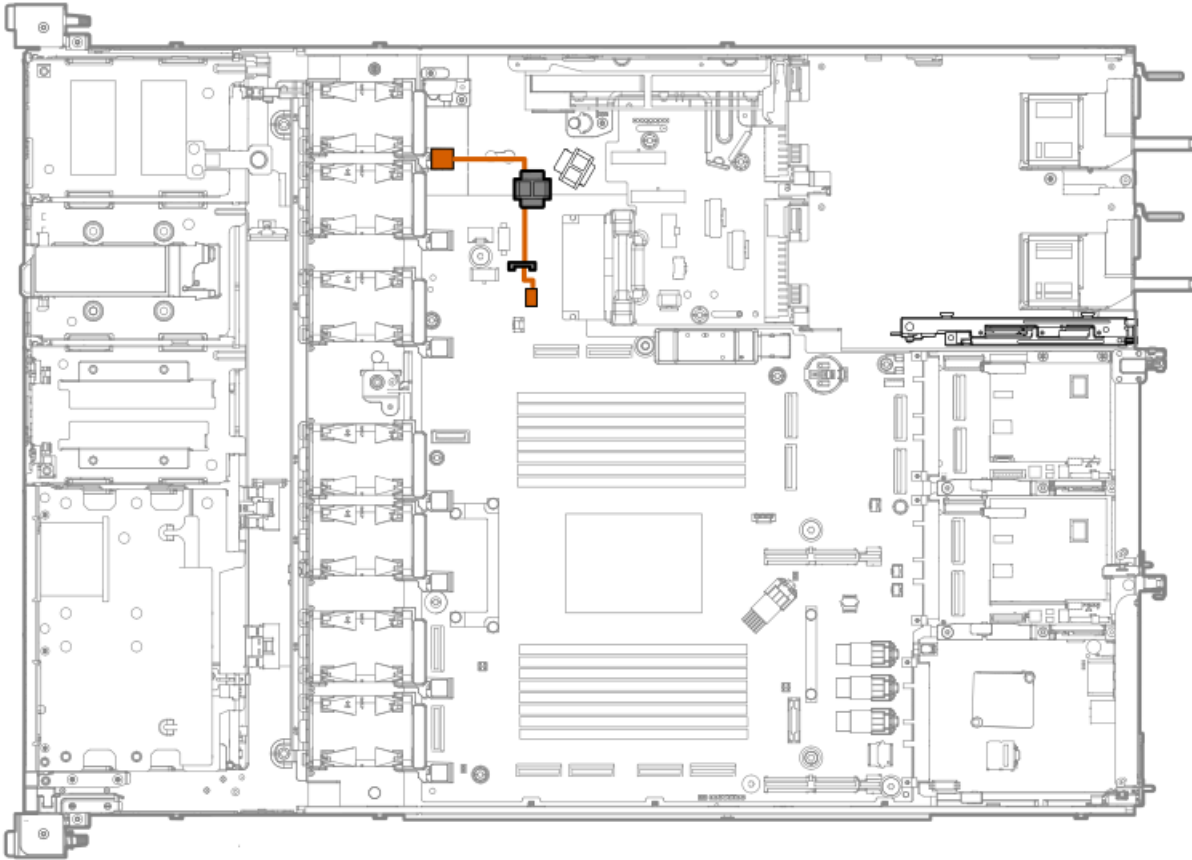

Cable part number	Color	From	To
P71914-001	Orange	Fan connector	Fan connector 1

Closed-loop liquid cooling heatsink cabling



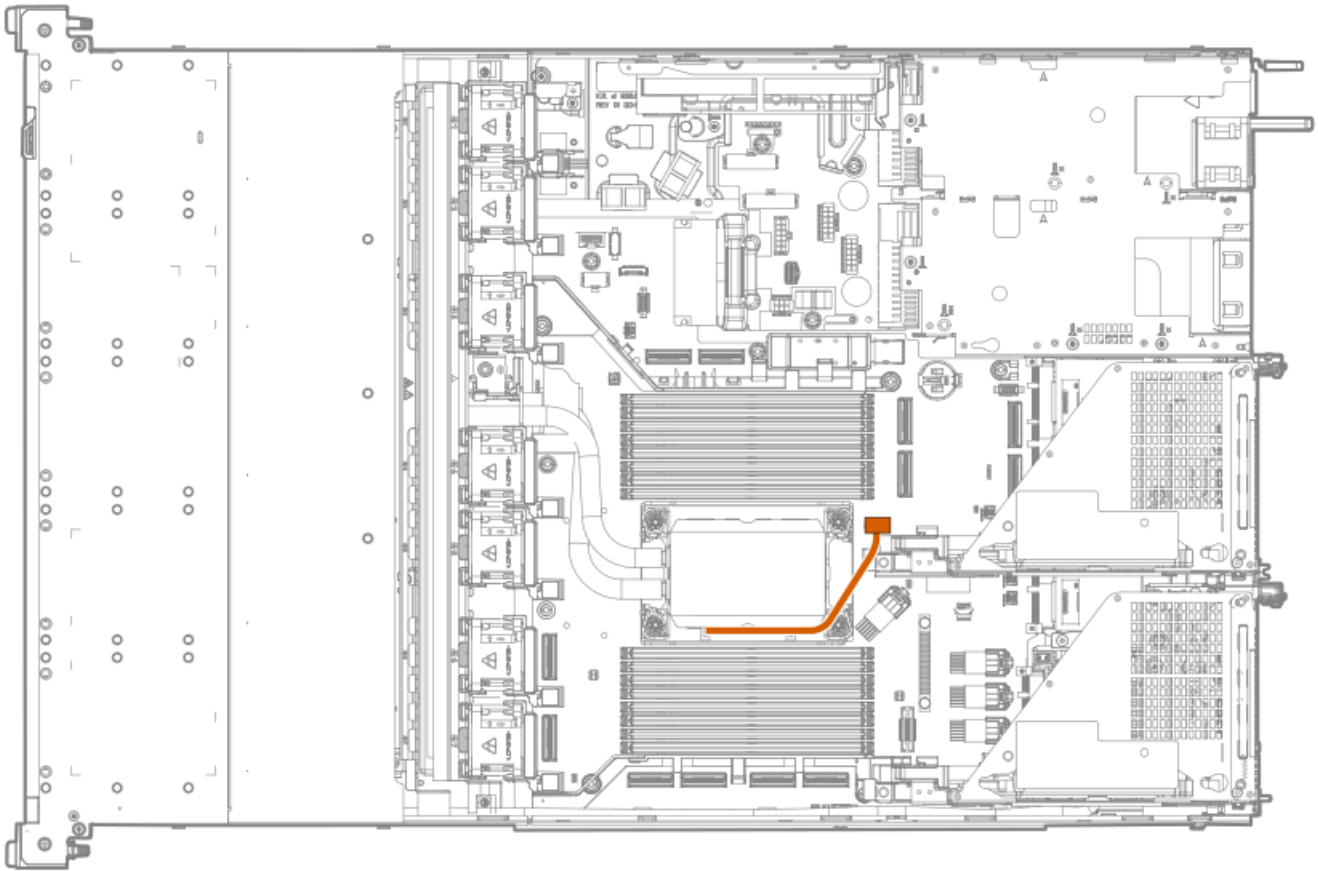

Cable part number	Color	From	To
—	Orange	Closed-loop liquid cooling heatsink	CLC connector

HPE NS204i-u Boot Device V2 cabling

In the power supply bay



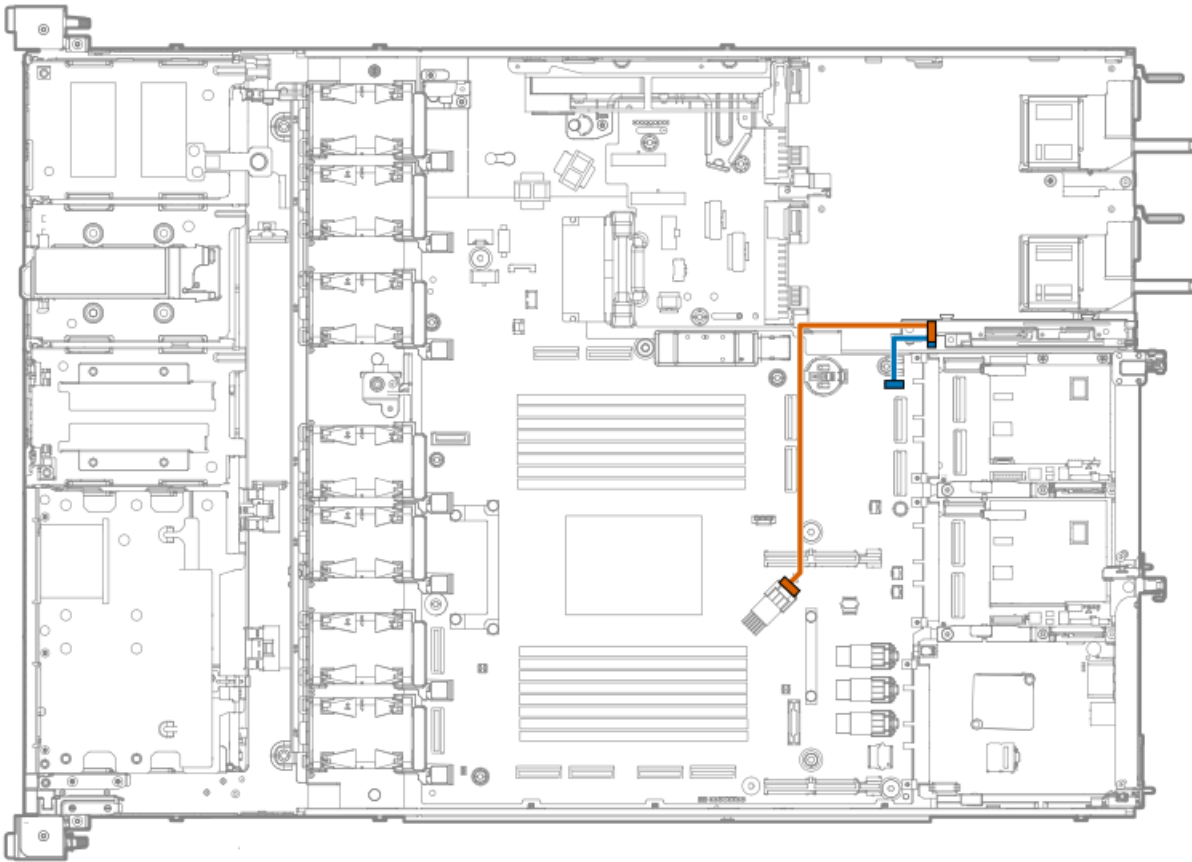

Cable part number	Color	From	To
P72024-001	Orange	Boot device carrier	NS204i-u signal connector
P63720-001	Blue	Boot device carrier	NS204i-u power connector

Between the riser cages

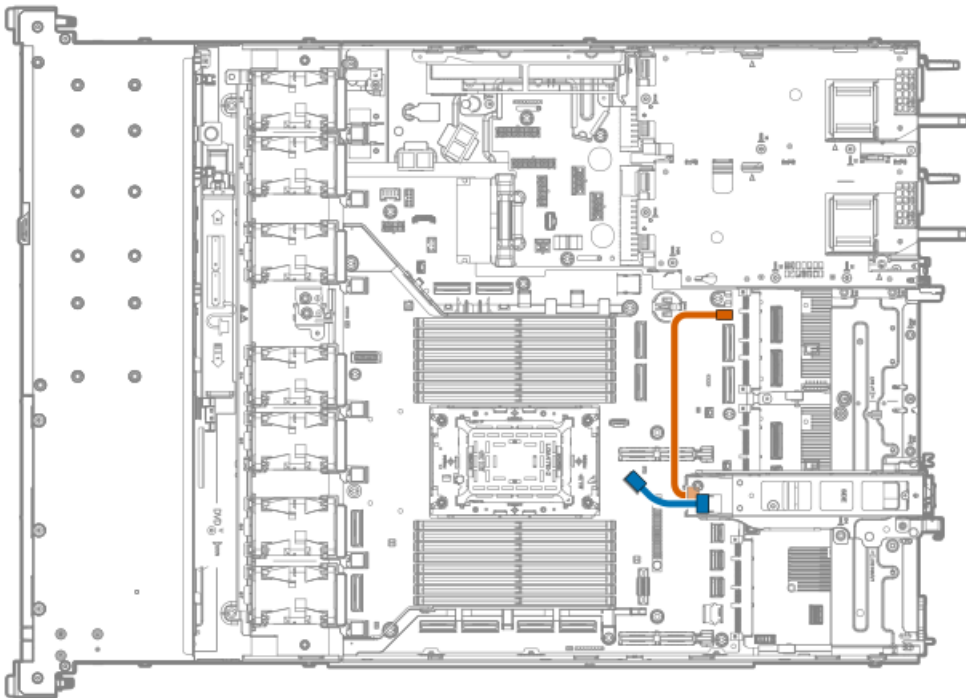

Cable part number	Color	From	To
P63720-001	Orange	Boot device carrier	NS204i-u power connector
P71913-001	Blue	Boot device carrier	NS204i-u signal connector

In box 3

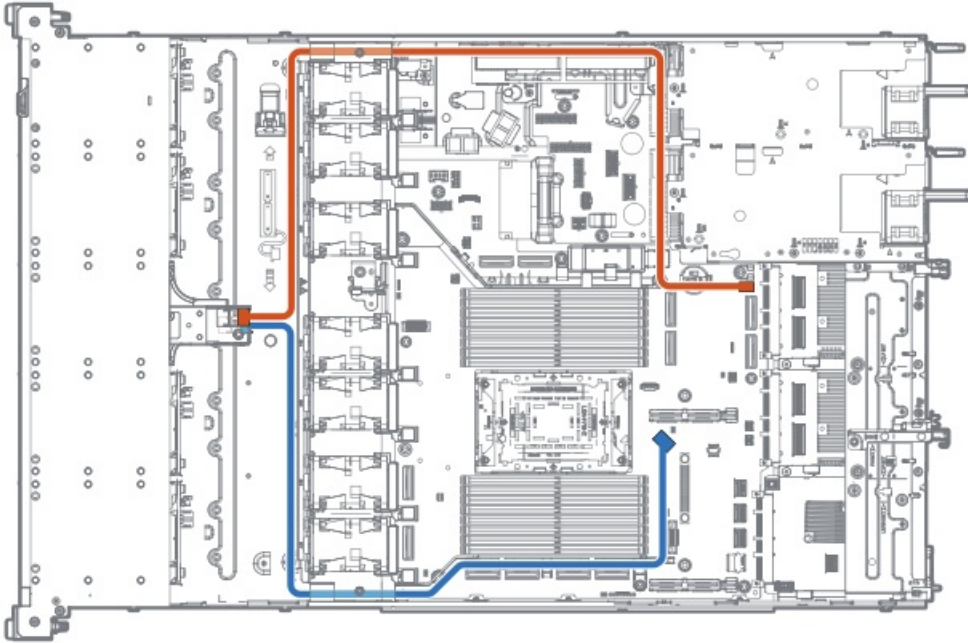

Cable part number	Color	From	To
P48956-001	Orange	Boot device carrier	NS204i-u power connector
P74730-001	Blue	Boot device carrier	NS204i-u signal connector

On the chassis

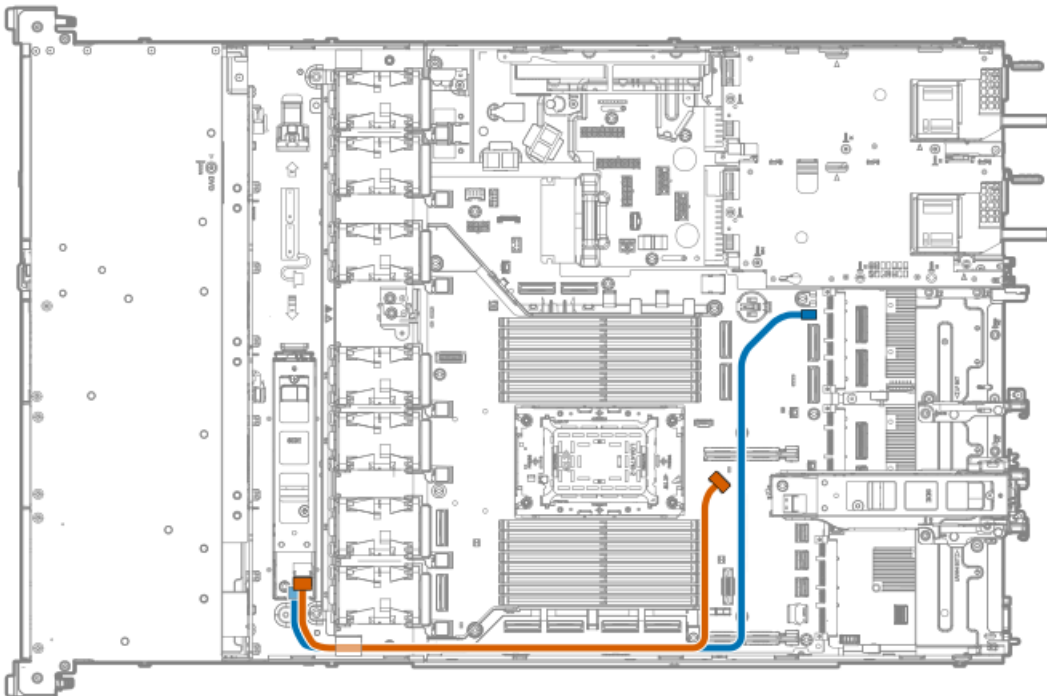

Cable part number	Color	From	To
P48956-001	Blue	Boot device carrier	NS204i-u power connector
P72024-001	Orange	Boot device carrier	NS204i-u signal connector

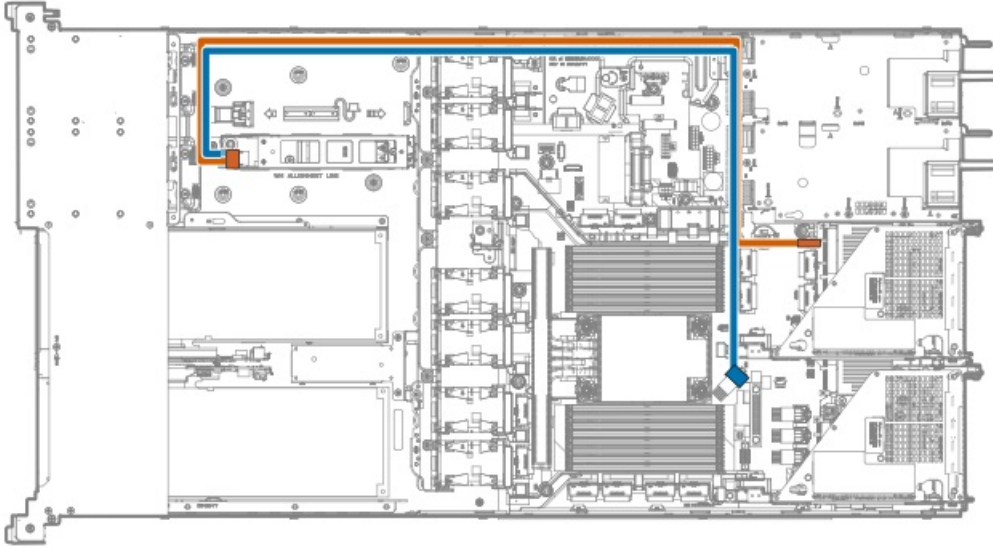

Cable part number	Color	From	To
P48956-001	Orange	Boot device carrier	NS204i-u power connector
P74730-001	Blue	Boot device carrier	NS204i-u signal connector

GPU cabling

Subtopics

[GPU auxiliary power cabling](#)

[GPU riser cabling](#)

GPU auxiliary power cabling

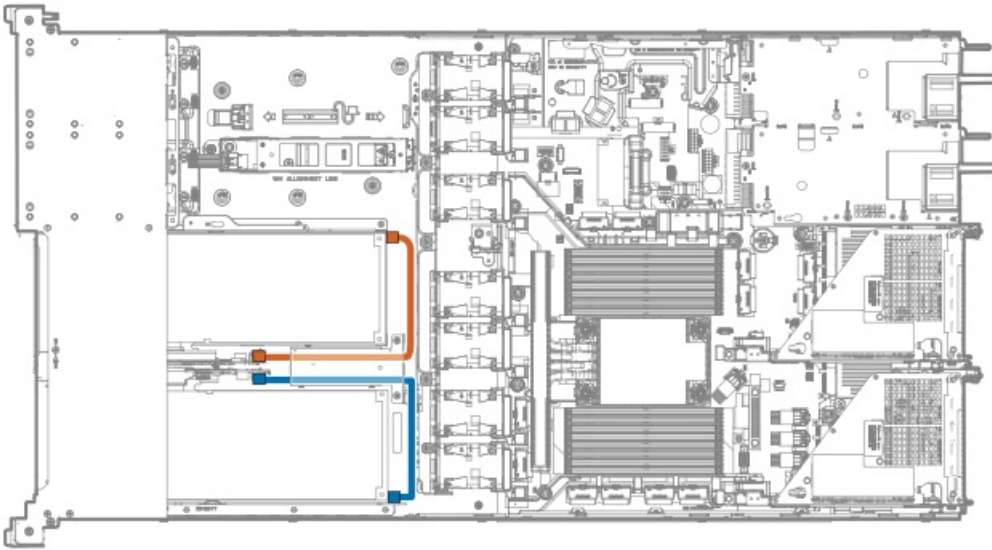

Cable part number	Color	From	To
P75256-001	Orange	GPU auxiliary power connector	GPU power port
	Blue	GPU auxiliary power connector	GPU power port

GPU riser cabling

GPU riser power cabling

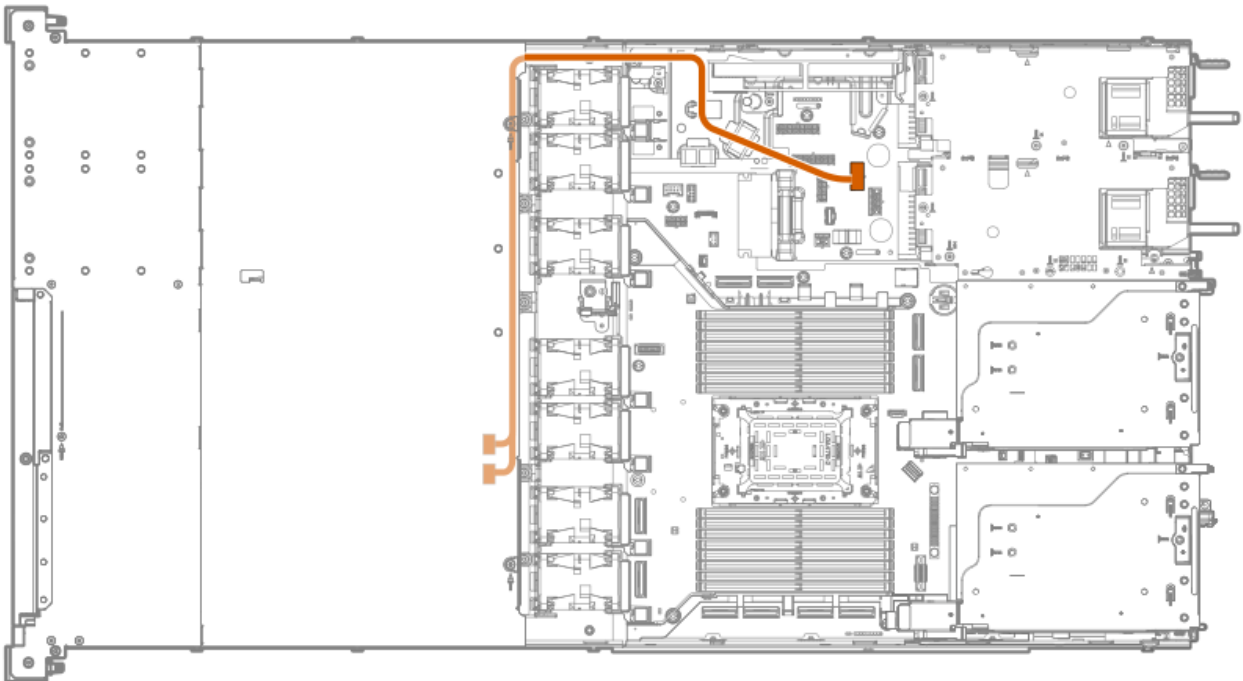

Cable part number	Color	From	To
P75594-001	Orange	Captive riser power connectors	2 x 6 M-PIC power connectors

GPU riser signal cabling

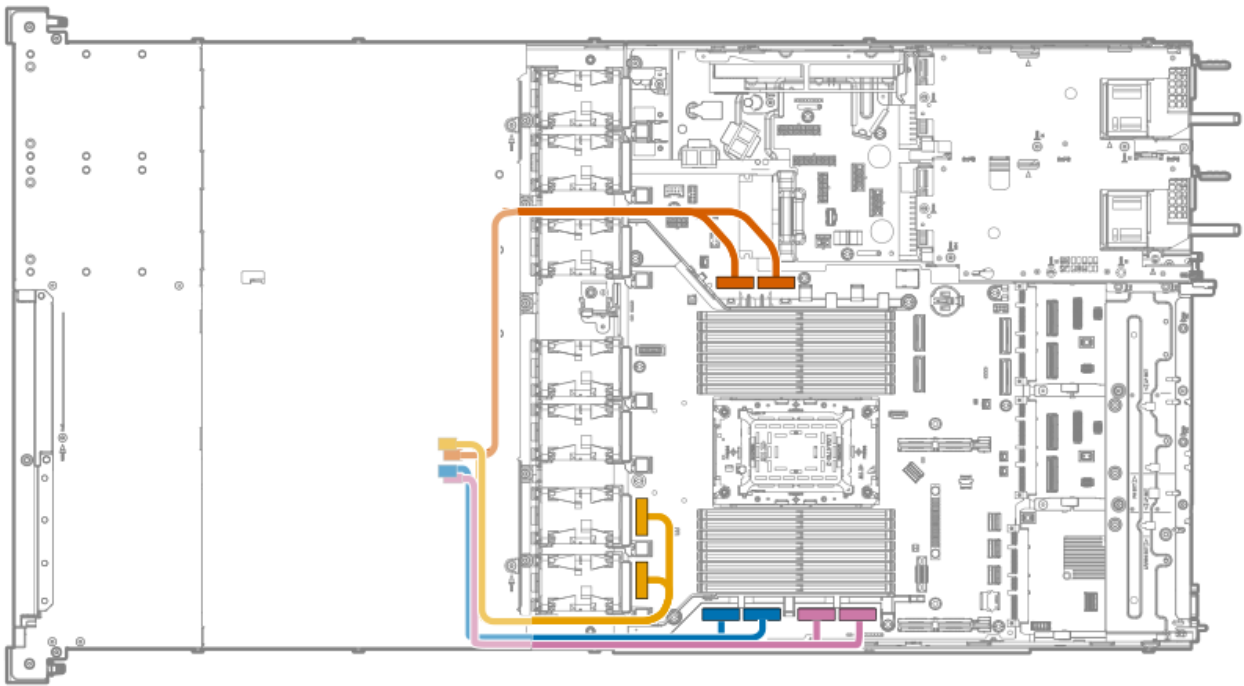

Cable part number	Color	From	To
P71886-001	Orange	Captive riser slot 3	M-XIO port 6 and M-XIO port 4
	Pink	Captive riser slot 6	M-XIO port 1 and M-XIO port 3
P73415-001	Gold	Captive riser slot 4	M-XIO port 0 and M-XIO port 2
	Blue	Captive riser slot 5	M-XIO port 7 and M-XIO port 5

Serial port cabling

Serial port cabling with the 60 mm power supply

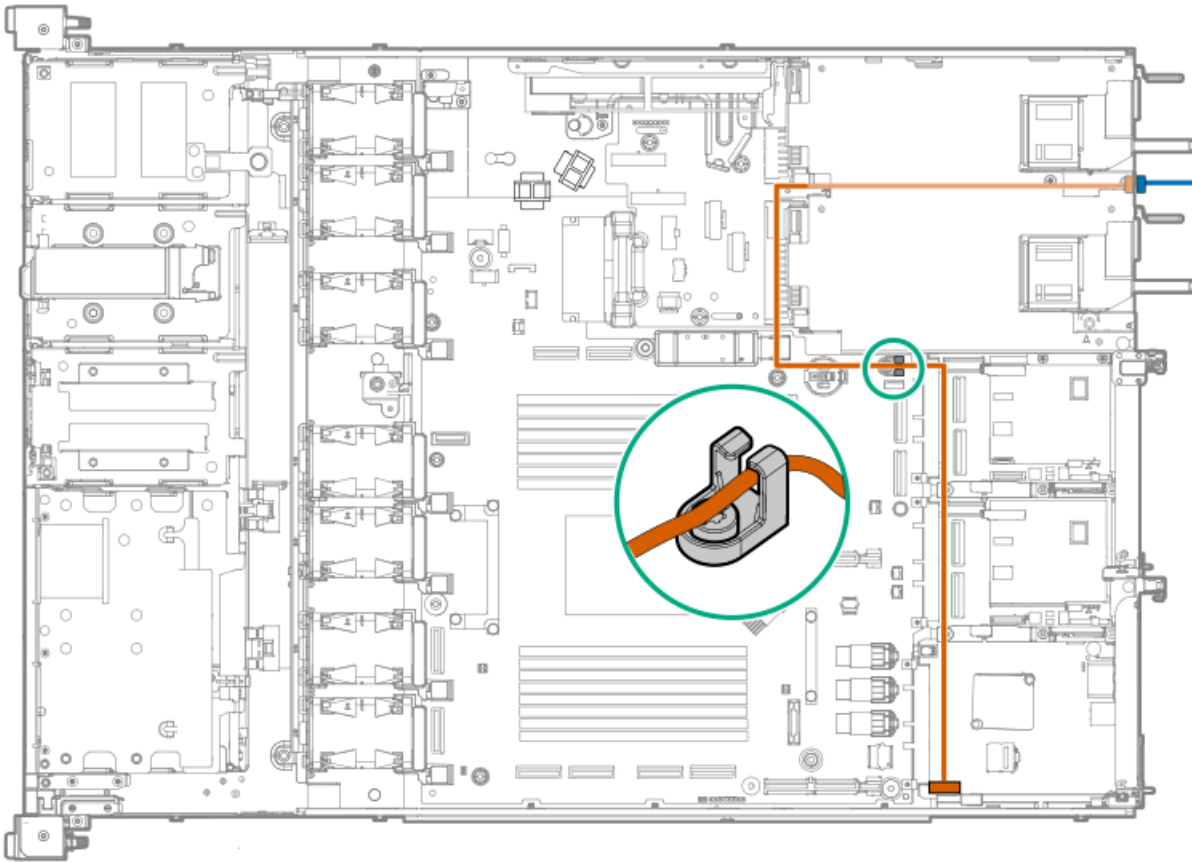

Cable part number	Color	From	To
P73744-001	Orange	ix port cable	Serial port cable connector ¹
P71826-001	Blue	Serial port dongle	ix port cable

¹ This port is located on the HPE ProLiant Compute iLO 6 DC-SCM.

Serial port cabling with the 73.5 mm power supply

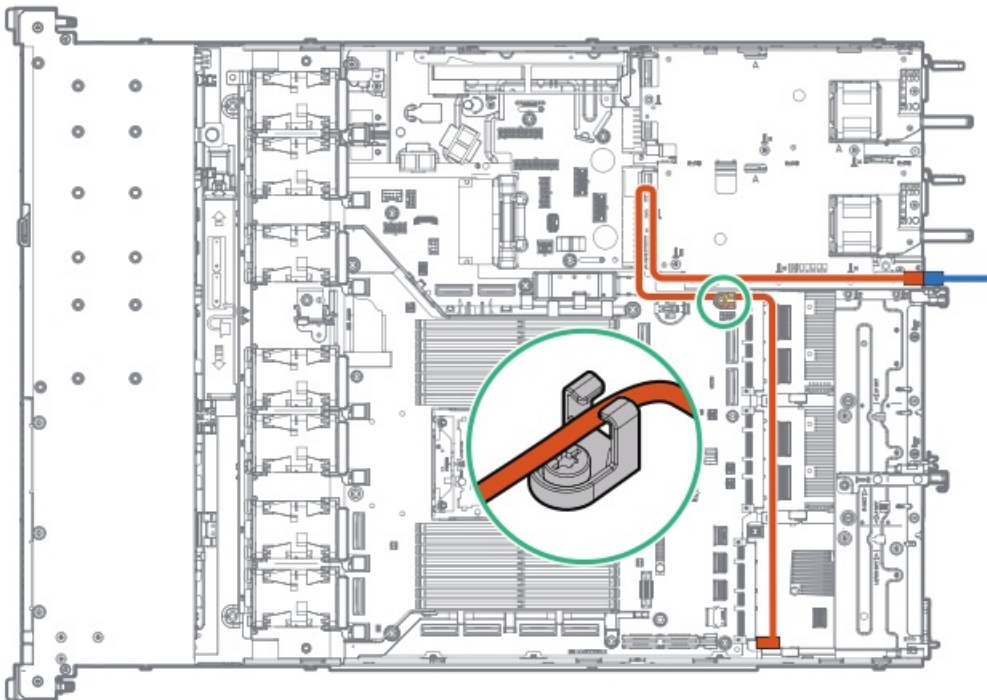

Cable part number	Color	From	To
P73744-001	Orange	ix port cable	Serial port cable connector
P71826-001	Blue	Serial port dongle	ix port cable

Optical drive cabling

8 SFF and mixed drive

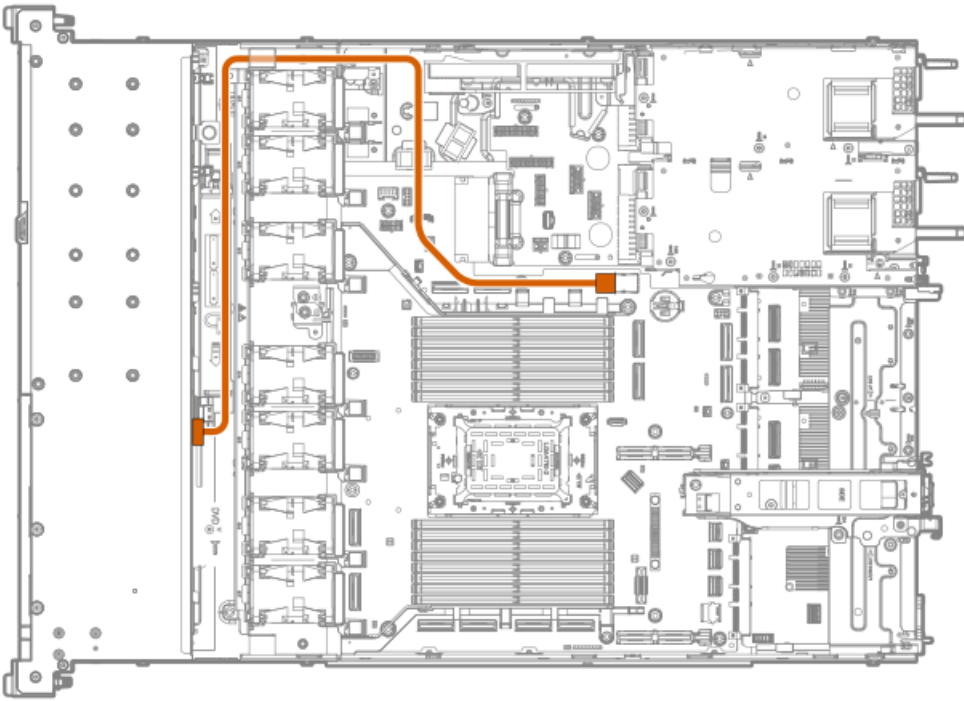

Cable part number	Color	From	To
P73776-002	Orange	Optical drive	USB 3.2 Gen1 port

4 LFF drive

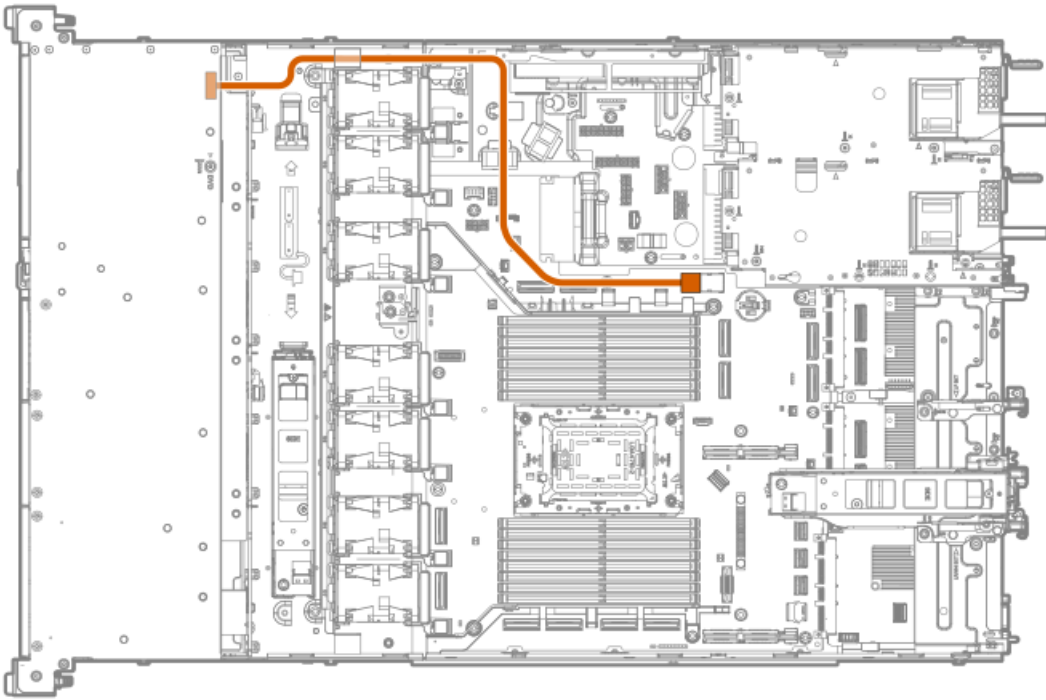

Cable part number	From	To
P73776-002	Optical drive	USB 3.2 Gen1 port

Display port cabling

SFF and E3.S drive

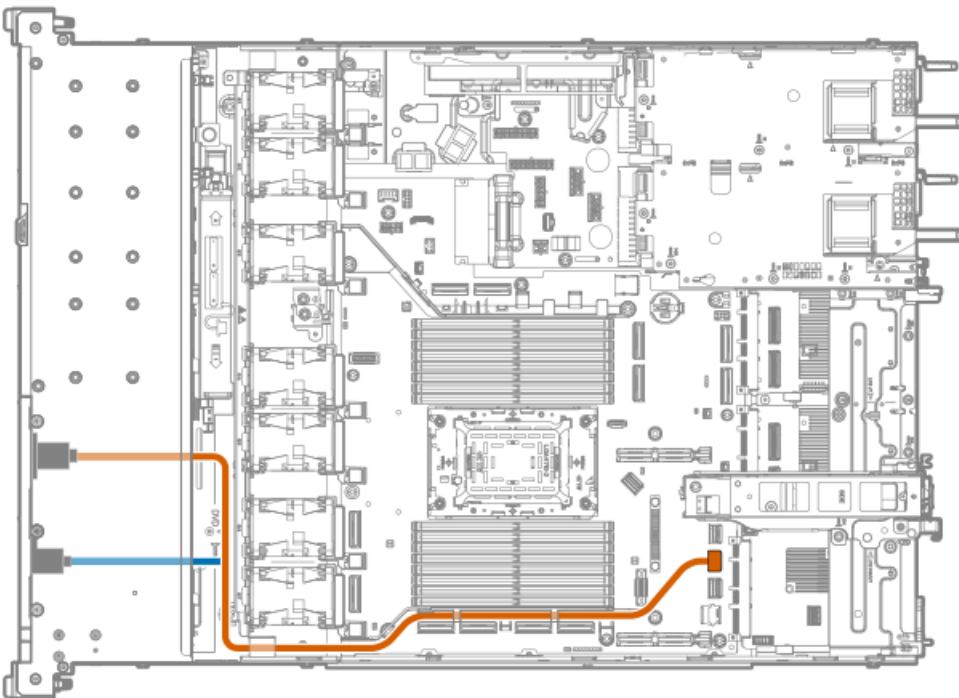

Cable part number	Color	From	To
P73948-001	Orange	Display port	USB 2.0 DisplayPort cable connector
	Blue	USB 2.0 port	

LFF drive

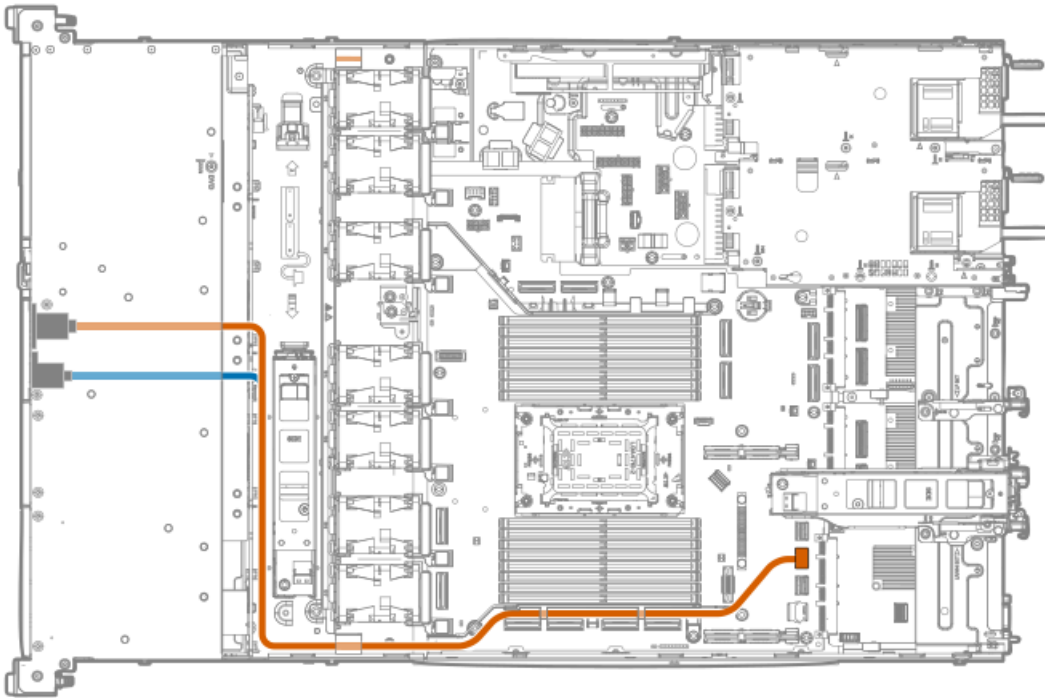

Cable part number	Color	From	To
P73948-001	Orange	Display port	USB 2.0 DisplayPort cable connector
	Blue	USB 2.0 port	

Systems Insight Display cabling



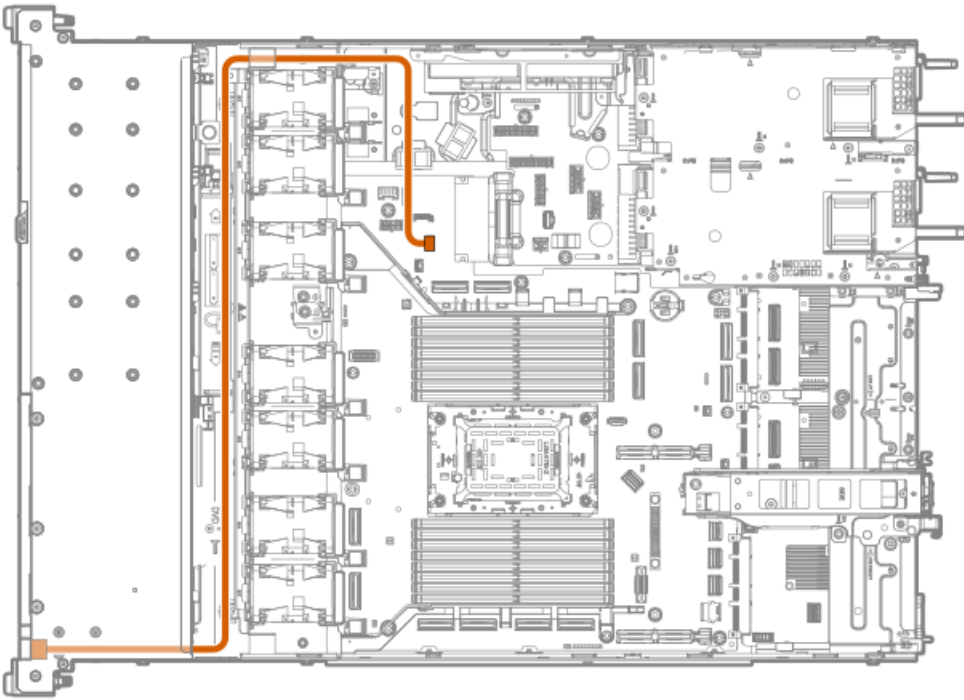

Cable part number	Color	From	To
P48971-001	Orange	SID	SID connector

Front OCP NIC and PHY board cabling

Primary OCP

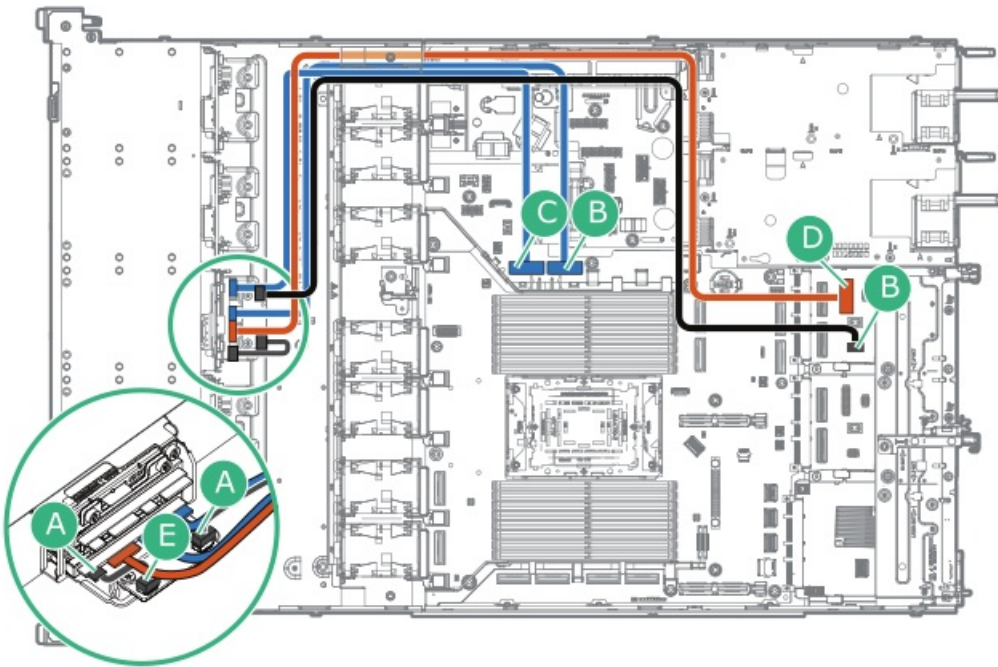

Cable part number	Color	From	To
P71941-001	Orange	Front OCP NIC cable	Front OCP NIC cable connector
	Blue	Front OCP NIC cable	M-XIO port 6 and M-XIO port 4
P73927-001	Black	PHY board cable connector	PHY board cable connector
—	Black	OCP NIC interposer connector	PHY board connector

Secondary OCP

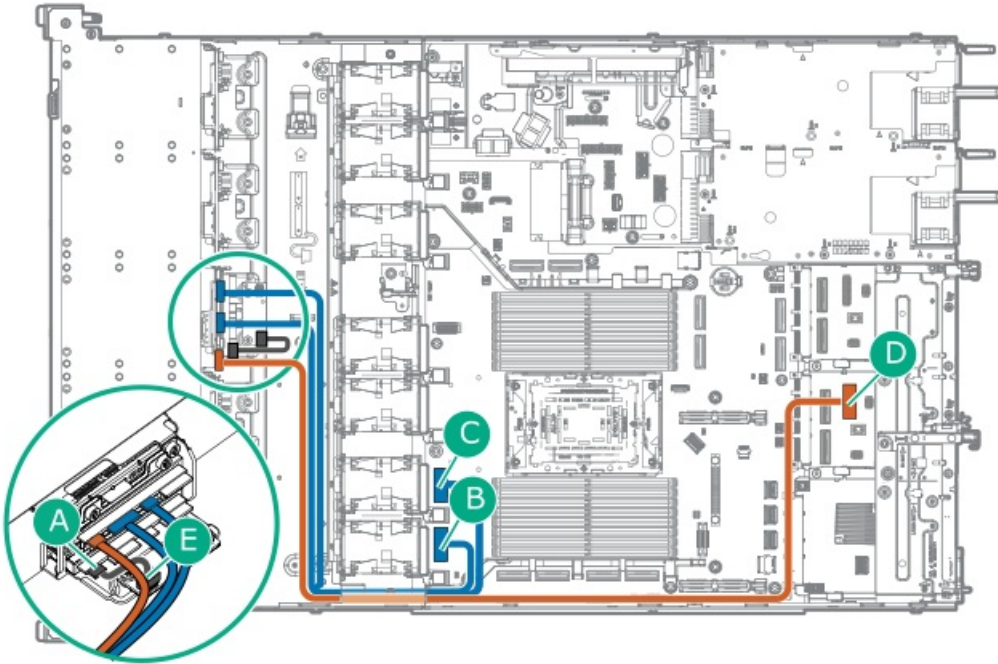

Cable part number	Color	From	To
P71941-001	Orange	Front OCP NIC cable	Front OCP NIC cable connector
	Blue	Front OCP NIC cable	M-XIO port 0 and M-XIO port 2
—	Black	OCP NIC interposer connector	PHY board connector

Rich I/O configuration: Primary OCP

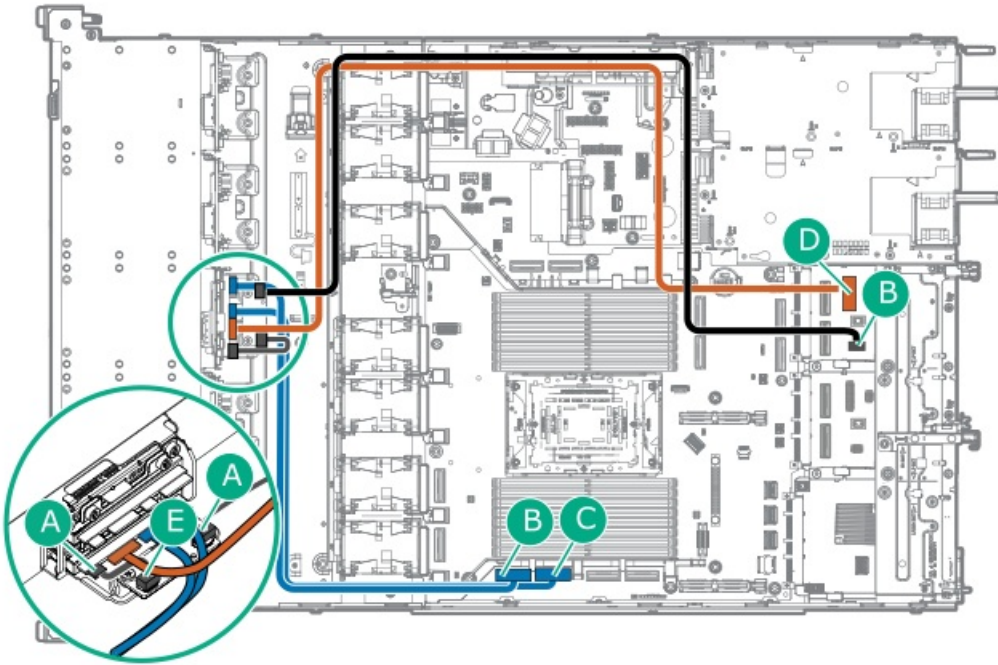

Cable part number	Color	From	To
P71941-001	Orange	Front OCP NIC cable	Front OCP NIC cable connector
	Blue	Front OCP NIC cable	M-XIO port 7 and M-XIO port 5
P73927-001	Black	PHY board	PHY board cable connector
—	Black	OCP NIC interposer connector	PHY board connector

Rich I/O configuration: Secondary OCP

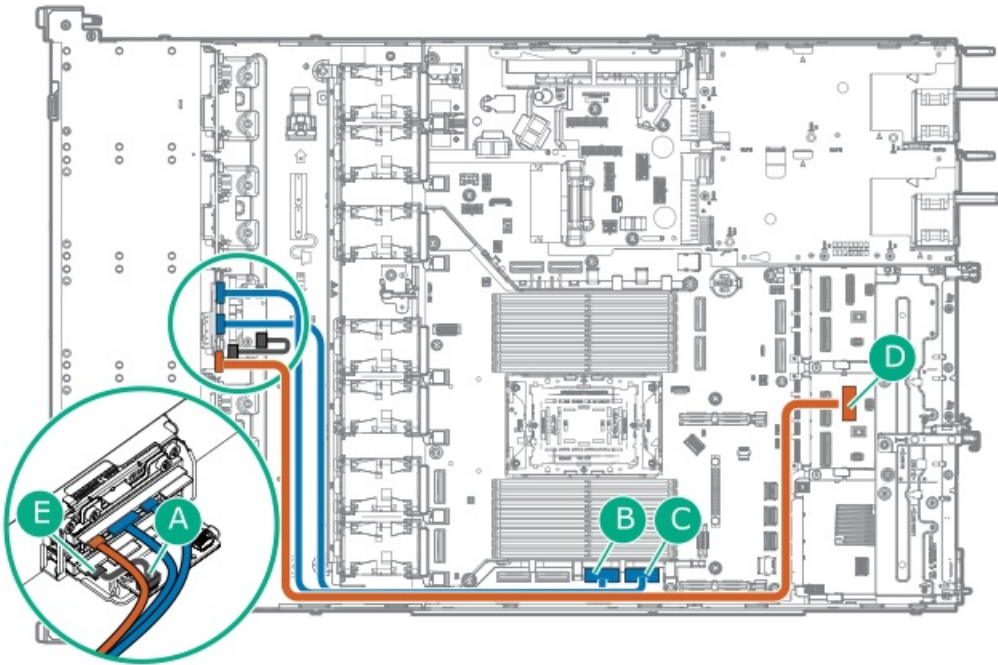

Cable part number	Color	From	To
P71941-001	Orange	Front OCP NIC cable	Front OCP NIC cable connector
	Blue	Front OCP NIC cable	M-XIO port 1 and M-XIO port 3
—	Black	OCP NIC interposer connector	PHY board cable connector

Rear OCP upgrade cabling

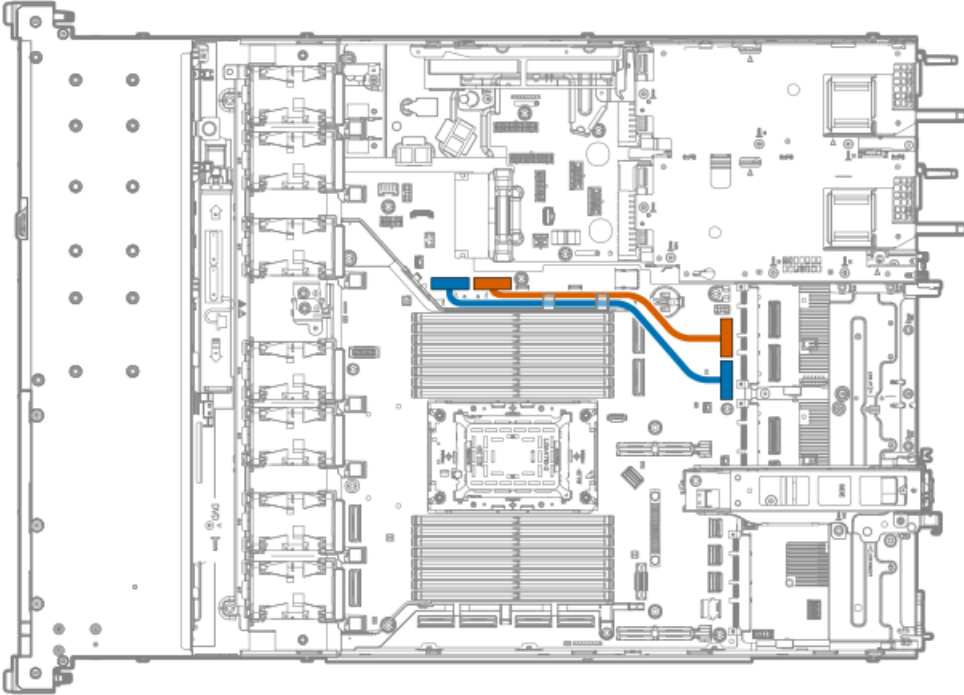

Cable part number	Color	From	To
P75506-001	Orange	M-XIO port 4	MCIO OCP B-1 input port
P75507-001	Blue	M-XIO port 6	MCIO OCP B-2 input port

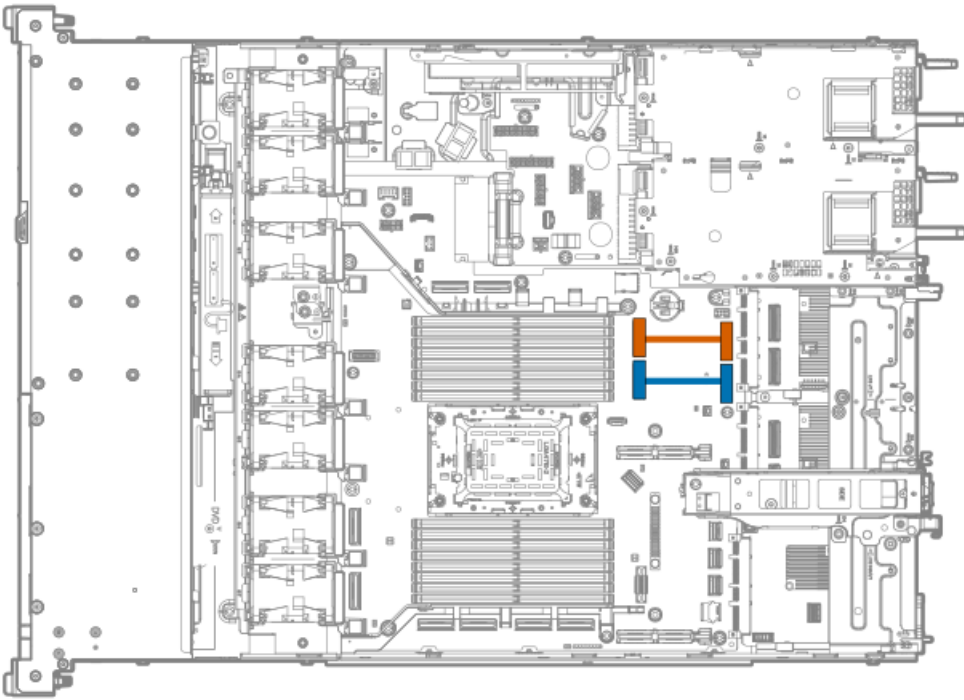

Cable part number	Color	From	To
P75591-001	Orange	M-XIO port 17	MCIO OCP B-1 input port
	Blue	M-XIO port 13	MCIO OCP B-2 input port

Full-height riser cage blanks are required for this connection.

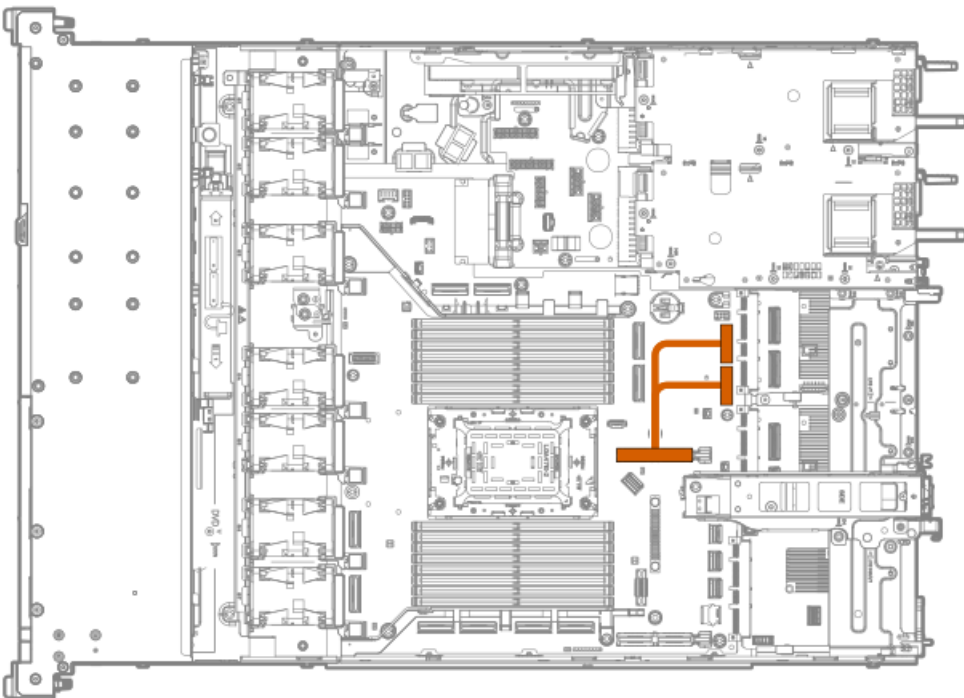

Cable part number	Color	From	To
P73494-001	Orange	Secondary riser connector	MCIO OCP B-1 input port and MCIO OCP B-2 input port



Front I/O cabling

SFF / E3.S / 4 LFF drive

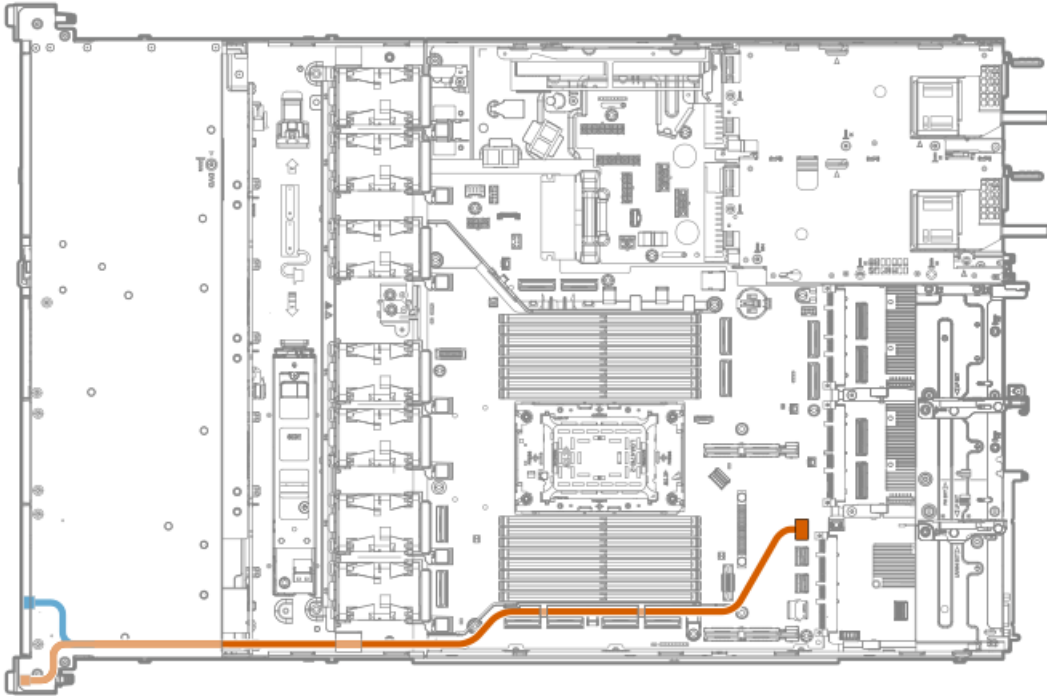

Cable part number	Color	From	To
P71909-001	Orange	USB 3.0	Front I/O connector
	Blue	Front I/O	

12 LFF drive

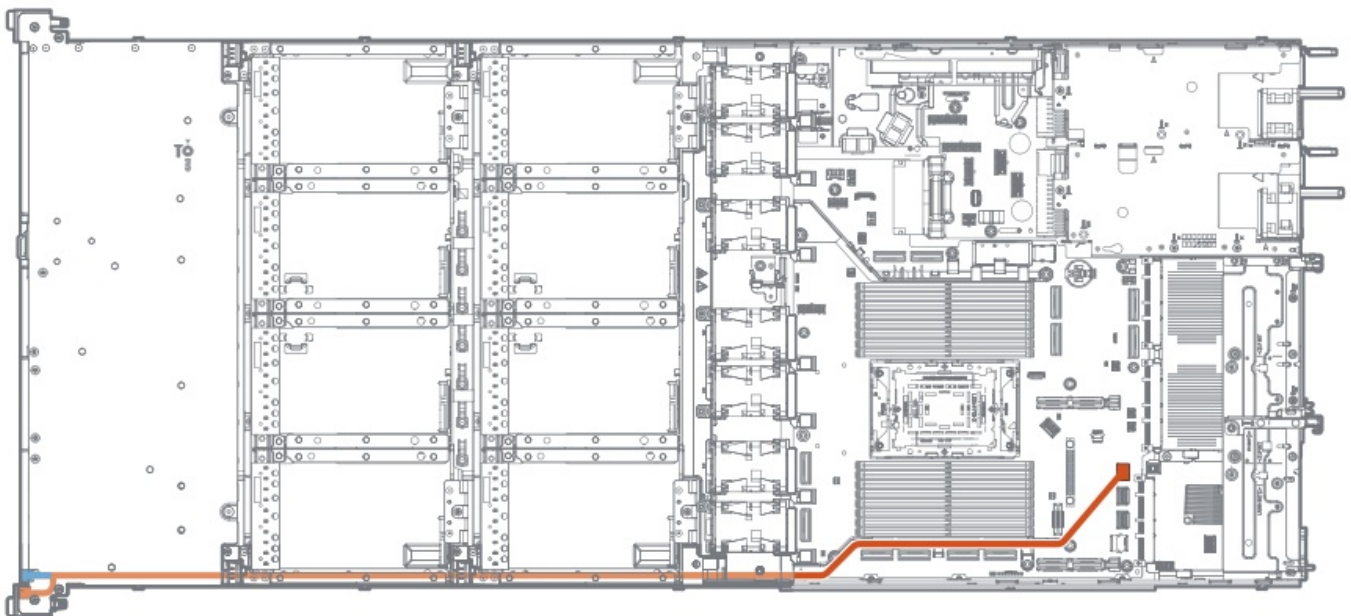

Cable part number	Color	From	To
P73417-001	Orange	USB 3.0	Front I/O connector
	Blue	Front I/O	

Mixed drive

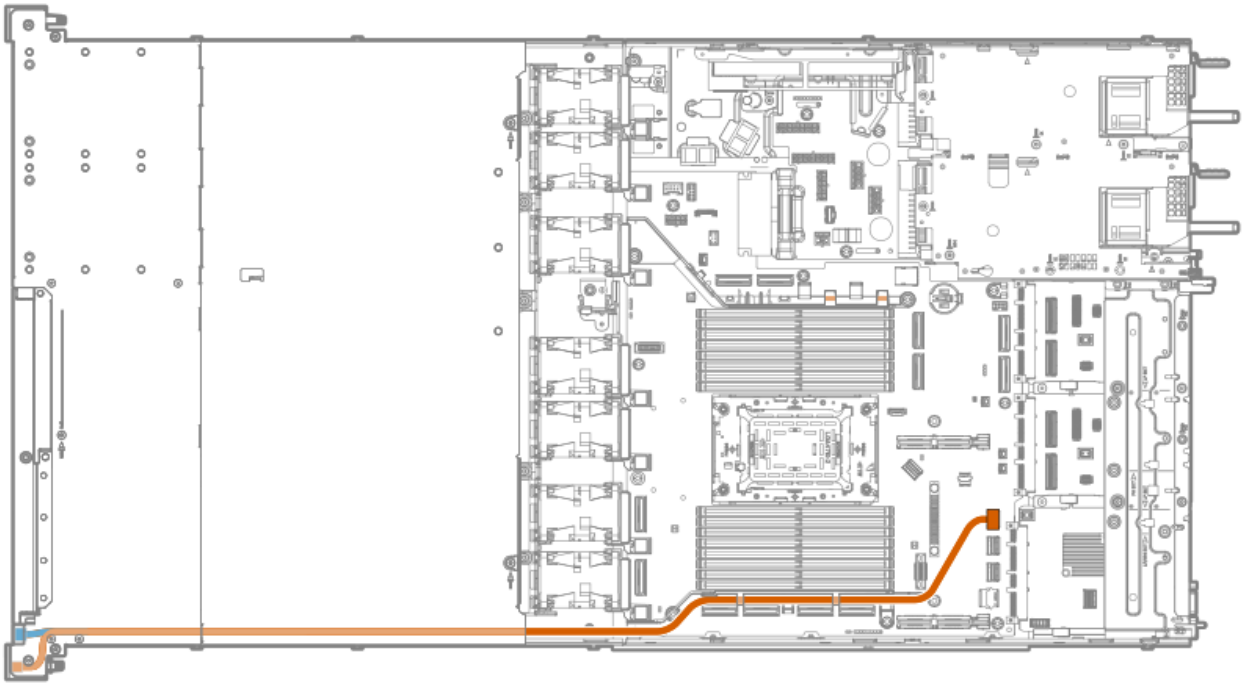

Cable part number	Color	From	To
P73417-001	Orange	USB 3.0	Front I/O connector
	Blue	Front I/O	

Chassis intrusion detection switch cabling

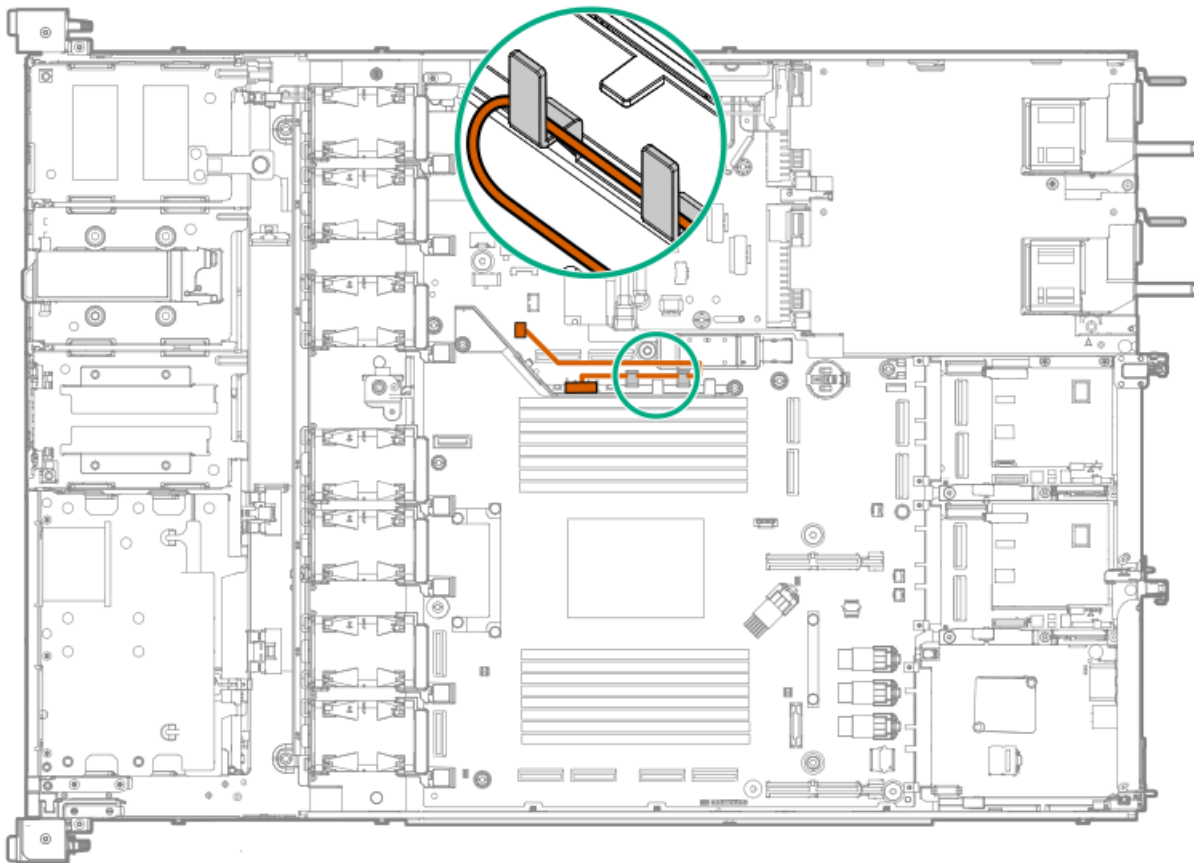

Cable part number	Color	From	To
869413-001	Orange	Chassis intrusion switch	Chassis intrusion switch connector

Configuration resources

Use the following resources to find documentation for configuring and managing your server.

- Some utilities might not apply to your server. For information about server compatibility with the products listed in this chapter, see the product QuickSpecs (<https://www.hpe.com/info/quickspecs>).
- Products ordered from HPE Factory Express might have already been configured with some or all the configurations in this chapter. To determine if any additional setup is required, see your HPE Factory Express order.
- For one-stop access to version-specific software and firmware documentation, including the latest product release notes, see this quick links page:
<https://www.hpe.com/support/hpeproductdocs-quicklinks>

Subtopics

[Updating firmware or system ROM](#)

[Configuring the server](#)

[Configuring storage controllers](#)

[Deploying an OS](#)

[Configuring security](#)

[Server management](#)

[Managing Linux-based high performance compute clusters](#)

Updating firmware or system ROM

To	Use
Download service packs	<ul style="list-style-type: none">• Service Pack for HPE ProLiant https://www.hpe.com/servers/spp/download• Get an overview of SPP and its ecosystem https://www.hpe.com/support/SPP-overview-videos-en
Deploy service packs to a single server	Smart Update Manager https://www.hpe.com/support/hpesmartupdatemanager-quicklinks
Deploy service packs to multiple servers	HPE OneView https://www.hpe.com/support/hpeoneview-quicklinks
Updating iLO or system firmware in a single server	iLO user guide https://www.hpe.com/support/hpeilodocs-quicklinks
<ul style="list-style-type: none">• Enable policy-based management of server or server group firmware for distributed server infrastructure• Monitor server compliance with a configured firmware baseline• Receive automatic iLO firmware updates• Receive baseline update alerts	HPE Compute Ops Management https://www.hpe.com/support/hpe-gl-com-quicklinks

Configuring the server

To configure

Use

Single server (GUI)

- Intelligent Provisioning
<https://www.hpe.com/support/hpeintelligentprovisioning-quicklinks>
- iLO remote console or web interface
<https://www.hpe.com/support/hpeilodocs-quicklinks>
- UEFI System Utilities
<https://www.hpe.com/support/hpeuefisystemutilities-quicklinks>
- HPE Compute Ops Management
<https://www.hpe.com/support/hpe-gl-com-quicklinks>

Single server (scripting)

- RESTful Interface Tool
<https://www.hpe.com/support/restfulinterface/docs>
- Python iLO Redfish Library (python-ilorest-library)
<https://github.com/HewlettPackard/python-ilorest-library>
- Scripting Tools for Windows Powershell
<https://www.hpe.com/info/powershell/docs>
- iLO RESTful API
<https://servermanagementportal.ext.hpe.com/>
- HPE Compute Ops Management API
<https://developer.greenlake.hpe.com/>

Multiple servers (either UI or scripting)

- HPE OneView ¹
<https://www.hpe.com/support/hpeoneview-quicklinks>
- HPE Compute Ops Management
<https://www.hpe.com/support/hpe-gl-com-quicklinks>
 - **Server settings:** Define server-specific parameters such as firmware baselines, and then apply them to server groups.
 - **Server groups:** Organize servers into custom-defined sets with associated server settings, and then apply group-specific policies to create a consistent configuration across the servers in the group.

¹ For servers running HPE OneView, do not use another tool, such as iLO, to delete or change certain settings. For more information about using HPE OneView and iLO to manage the same server, see the iLO user guide at <https://www.hpe.com/support/hpeilodocs-quicklinks>.

Configuring storage controllers

Controller type	Documentation
HPE MR Gen12 controllers	<p>HPE MR Gen12 Controller User Guide</p> <p>https://hpe.com/support/MR-Gen12-UG</p> <p>Configuration guides:</p> <ul style="list-style-type: none"> • HPE MR Storage Administrator User Guide <p>https://www.hpe.com/support/MRSA</p> <ul style="list-style-type: none"> • HPE StorCLI User Guide <p>https://www.hpe.com/support/StorCLI</p>

Deploying an OS

For a list of supported operating systems, see the HPE Servers Support & Certification Matrices:

<https://www.hpe.com/support/Servers-Certification-Matrices>

To	See
Deploy an OS using HPE Compute Ops Management	<p>HPE Compute Ops Management User Guide</p> <p>https://www.hpe.com/support/hpe-gl-com-quicklinks</p>
Deploy an OS using Intelligent Provisioning	<p>Intelligent Provisioning user guide</p> <p>https://www.hpe.com/support/hpeintelligentprovisioning-quicklinks</p>
Deploy an OS using iLO virtual media	<p>iLO user guide</p> <p>https://www.hpe.com/support/hpeilodocs-quicklinks</p>
Configure the server to boot from a PXE server	<p>UEFI System Utilities User Guide for HPE Compute servers</p> <p>https://www.hpe.com/support/UEFIGen12-UG-en</p>
Configure the server to boot from a SAN	<p>HPE Boot from SAN Configuration Guide</p> <p>https://www.hpe.com/info/boot-from-san-config-guide</p>

Configuring security

To	See
Implement server security best practices.	<ul style="list-style-type: none"> • HPE Compute Security Reference Guide <p>https://www.hpe.com/info/server-security-reference-en</p> <ul style="list-style-type: none"> • HPE iLO 7 Security Technology Brief <p>https://www.hpe.com/support/ilo7-security-en</p>
Configure and use the Server Configuration Lock feature on HPE Trusted Supply Chain servers and other servers that have the Server Configuration Lock feature enabled.	<p>Server Configuration Lock User Guide for HPE ProLiant servers and HPE Synergy</p> <p>https://www.hpe.com/info/server-config-lock-UG-en</p>

Server management

To monitor	See
Single server	HPE iLO https://www.hpe.com/support/hpeilodocs-quicklinks
Multiple servers	HPE OneView https://www.hpe.com/support/hpeoneview-quicklinks
Single or multiple servers	HPE Compute Ops Management https://www.hpe.com/support/hpe-gl-com-quicklinks

Managing Linux-based high performance compute clusters

To	Use
Provision, manage, and monitor clusters.	HPE Performance Cluster Manager https://www.hpe.com/support/hpcm_manuals
Optimize your applications.	HPE Performance Analysis Tools https://www.hpe.com/info/perftools
Optimize software library for low latency and high bandwidth, both on-node and off-node, for point-to-point and collective communications.	HPE Cray Programming Environment User Guide https://www.hpe.com/info/cray-pe-user-guides

Safety, warranty, and regulatory information

Subtopics

[Regulatory information](#)

[Warranty information](#)

Regulatory information

To view the regulatory information for your product, view the Safety and Compliance Information for Server, Storage, Power, Networking, and Rack Products, available at the Hewlett Packard Enterprise Support Center:

<https://www.hpe.com/support/Safety-Compliance-EnterpriseProducts>

Additional regulatory information

Hewlett Packard Enterprise is committed to providing our customers with information about the chemical substances in our products as needed to comply with legal requirements such as REACH (Regulation EC No 1907/2006 of the European Parliament and the Council). A chemical information report for this product can be found at:

<https://www.hpe.com/info/reach>

For Hewlett Packard Enterprise product environmental and safety information and compliance data, including RoHS and REACH, see:

<https://www.hpe.com/info/ecodata>

For Hewlett Packard Enterprise environmental information, including company programs, product recycling, and energy efficiency, see:

<https://www.hpe.com/info/environment>

Subtopics

[Notices for Eurasian Economic Union](#)

[Turkey RoHS material content declaration](#)

[Ukraine RoHS material content declaration](#)

Notices for Eurasian Economic Union



Manufacturer and Local Representative Information

Manufacturer information:

Hewlett Packard Enterprise Company, 1701 E Mossy Oaks Road, Spring, TX 77389 U.S.

Local representative information Russian:

- **Russia**
ООО "Хьюлетт Паккард Энтерпрайз", Российская Федерация, 125171, г. Москва, Ленинградское шоссе, 16А, стр.3, Телефон: +7 499 403 4248 Факс: +7 499 403 4677
- **Kazakhstan**
ТОО «Хьюлетт-Паккард (К)», Республика Казахстан, 050040, г. Алматы, Бостандыкский район, проспект Аль-Фараби, 77/7, Телефон/факс: + 7 727 355 35 50

Local representative information Kazakh:

- **Russia**
ЖШС "Хьюлетт Паккард Энтерпрайз", Ресей Федерациясы, 125171, Мәскеу, Ленинград тас жолы, 16А блок 3, Телефон: +7 499 403 4248 Факс: +7 499 403 4677
- **Kazakhstan**
ЖШС «Хьюлетт-Паккард (К)», Қазақстан Республикасы, 050040, Алматы қ., Бостандық ауданы, Әл-Фараби даңғ ылы, 77/7, Телефон/факс: +7 727 355 35 50

Manufacturing date:

The manufacturing date is defined by the serial number.

CCSYWWZZZZ (product serial number format)

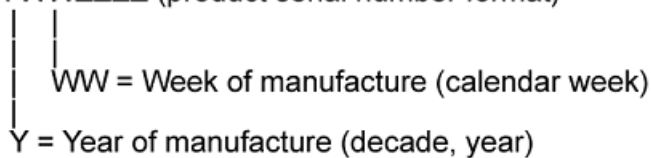

If you need help identifying the manufacturing date, contact tre@hpe.com.

Turkey RoHS material content declaration

Türkiye Cumhuriyeti: AEEE Yönetmeliğine Uygundur

Ukraine RoHS material content declaration

Обладнання відповідає вимогам Технічного регламенту щодо обмеження використання деяких небезпечних речовин в електричному та електронному обладнанні, затвердженого постановою Кабінету Міністрів України від 3 грудня 2008 № 1057

Warranty information

To view the warranty information for your product, see the [warranty check tool](#).

Specifications

Subtopics

[Environmental specifications](#)

[Mechanical specifications](#)

[Power supply specifications](#)

Environmental specifications

Specifications	Value
Temperature range	—
Operating	10°C to 35°C (50°F to 95°F)
Nonoperating	Air-cooled systems: -30°C to 60°C (-22°F to 140°F) Liquid-cooled systems (DLC, CLLC): -10°C to 60°C (14°F to 140°F) CAUTION: To prevent freezing the coolant and damaging the liquid cooling module, do not keep the liquid-cooled systems below -10°C (14°F).
Relative humidity (noncondensing)	—
Operating	8% to 90% 28°C (82.4°F) maximum wet bulb temperature, noncondensing
Nonoperating	5% to 95% 38.7°C (101.7°F) maximum wet bulb temperature, noncondensing
Altitude	—
Operating	3050 m (10,000 ft) This value may be limited by the type and number of options installed. Maximum allowable altitude change rate is 457 m/min (1,500 ft/min).
Nonoperating	9144 m (30,000 ft) Maximum allowable altitude change rate is 457 m/min (1,500 ft/min).

Standard operating support

10° to 35°C (50° to 95°F) at sea level with an altitude derating of 1.0°C per every 305 m (1.8°F per every 1,000 ft) above sea level to a maximum of 3,050 m (10,000 ft), no direct sustained sunlight. Maximum rate of change is 20°C/hr (36°F/hr). The upper limit and rate of change might be limited by the type and number of options installed.

System performance under standard operating support might be reduced if operating above 30°C (86°F) or with a faulty fan installed.

Extended ambient operating support

For approved hardware configurations, the supported system inlet range is extended to be:

- 5° to 10°C (41° to 50°F) and 35° to 40°C (95° to 104°F) at sea level with an altitude derating of 1.0°C per every 175 m (1.8°F per every 574 ft) above 900 m (2,953 ft) to a maximum of 3050 m (10,000 ft).
- 40°C to 45°C (104°F to 113°F) at sea level with an altitude derating of 1.0°C per every 125 m (1.8°F per every 410 ft) above 900 m (2953 ft) to a maximum of 3,050 m (10,000 ft).

The approved hardware configurations for this system are listed in the Extended Ambient Temperature Guidelines for Gen12 Servers:
<https://www.hpe.com/support/ASHRAEGen12>

Mechanical specifications

Specification	Value
8 SFF drive configuration	—
Height	4.29 cm (1.69 in)
Depth	60.94 cm (23.92 in)
Width	43.46 cm (17.11 in)
Weight, minimum	11.05 kg (24.36 lb)
Weight, maximum	17.25 kg (38.03 lb)
10 SFF / 20 E3.S drive configuration	—
Height	4.29 cm (1.69 in)
Depth	66.70 cm (28.26 in)
Width	43.46 cm (17.11 in)
Weight, minimum	11.42 kg (25.18 lb)
Weight, maximum	18.71 kg (41.25 lb)
4 LFF drive configuration	—
Height	4.29 cm (1.69 in)
Depth	66.70 cm (28.26 in)
Width	43.46 cm (17.11 in)
Weight, minimum	12.34 kg (27.21 lb)
Weight, maximum	18.34 kg (40.43 lb)
12 LFF drive configuration	—
Height	4.29 cm (1.69 in)
Depth	99.74 cm (39.27 in)
Width	43.46 cm (17.11 in)
Weight, minimum	17.48 kg (38.54 lb)
Weight, maximum	28.93 kg (63.78 lb)
GPU configuration	—
Height	4.29 cm (1.69 in)
Depth	82.18 cm (32.35 in)
Weight, minimum	15.14 kg (33.38 lb)
Weight, maximum	21.53 kg (47.47 lb)

Power supply specifications

Depending on the installed options and the regional location where the server was purchased, the server can be configured with one of the following power supplies. For detailed power supply specifications, see the QuickSpecs on the [Hewlett Packard Enterprise website](#).

Subtopics

[HPE 800 W M-CRPS Platinum Hot-plug Power Supply](#)

[HPE 1000 W M-CRPS Titanium Hot-plug Power Supply](#)

[HPE 1500 W M-CRPS Titanium Hot-plug Power Supply](#)

[HPE 2400 W M-CRPS Titanium Hot-plug Power Supply](#)

HPE 800 W M-CRPS Platinum Hot-plug Power Supply

Specification	Value
Energy efficiency certification	80 Plus Platinum, 94%
Input requirements	—
Rated input voltage	Low-line input voltage: 100 VAC to 120 VAC High-line input voltage: 200 VAC to 240 VAC 240 VDC for China
Rated input frequency	50 Hz to 60 Hz
Rated input current	8 A at 100 VAC to 120 VAC 5 A at 200 VAC to 240 VAC
Maximum rated input power	723 W at 100 VAC 717 W at 110 VAC 713 W at 120 VAC 864 W at 200 VAC 863 W at 208 VAC 861 W at 230 VAC 860 W at 240 VAC 861 W at 240 VDC
BTUs per hour	2466 at 100 VAC 2447 at 110 VAC 2433 at 120 VAC 2949 at 200 VAC 2946 at 208 VAC 2938 at 230 VAC 2935 at 240 VAC 2939 at 240 VDC
Power supply output	—
Rated steady-state power	Low-line input voltage: 650 W at 100 VAC to 120 VAC High-line input voltage: 800 W at 200 VAC to 240 VAC input
Maximum peak power	650 W at 100 VAC to 120 VAC 800 W at 200 VAC to 240 VAC input
Dimensions	—
Height	40.00 mm (1.57 in)
Depth	185.00 mm (7.28 in)
Width	60.00 mm (2.36 in)

HPE 1000 W M-CRPS Titanium Hot-plug Power Supply

Specification	Value
Energy efficiency certification	80 Plus Titanium, 96%
Input requirements	—
Rated input voltage	Low-line input voltage: 100 VAC to 120 VAC High-line input voltage: 200 VAC to 240 VAC 240 VDC for China
Rated input frequency	50 Hz to 60 Hz
Rated input current	10 A at 100 VAC 6 A at 200 VAC
Maximum rated input power	800 W at 100 VAC 1000 W at 200 VAC
BTUs per hour	3044 at 100 VAC 3680 at 200 VAC
Power supply output	—
Rated steady-state power	Low-line input voltage: 800 W at 100 VAC to 120 VAC High-line input voltage: 1000 W at 200 VAC to 240 VAC input
Maximum peak power	800 W at 100 VAC to 120 VAC 1000 W at 200 VAC to 240 VAC input
Dimensions	—
Height	40.00 mm (1.57 in)
Depth	185.00 mm (7.28 in)
Width	60.00 mm (2.36 in)

HPE 1500 W M-CRPS Titanium Hot-plug Power Supply

Specification	Value
Energy efficiency certification	80 Plus Titanium, 96%
Input requirements	—
Rated input voltage	Low-line input voltage: 100 VAC to 110 VAC Low-line input voltage: 110 VAC to 120 VAC High-line input voltage: 200 VAC to 240 VAC 240 VDC for China
Rated input frequency	50 Hz to 60 Hz
Rated input current	12 A at 100 VAC 12 A at 110 VAC 9 A at 200 VAC
Maximum rated input power	1000 W at 100 VAC 1100 W at 110 VAC 1500 W at 200 VAC
BTUs per hour	3792 at 100 VAC 5560 at 200 VAC
Power supply output	—
Rated steady-state power	Low-line input voltage: 1000 W at 100 VAC to 110 VAC Low-line input voltage: 1100 W at 110 VAC to 120 VAC High-line input voltage: 1500 W at 200 VAC to 240 VAC input
Maximum peak power	1000 W at 100 VAC to 110 VAC 1100 W at 110 VAC to 120 VAC 1500 W at 200 VAC to 240 VAC input
Dimensions	—
Height	40.00 mm (1.57 in)
Depth	185.00 mm (7.28 in)
Width	60.00 mm (2.36 in)

HPE 2400 W M-CRPS Titanium Hot-plug Power Supply

Specification	Value
Energy efficiency certification	80 Plus Titanium, 96%
Input requirements	—
Rated input voltage	Low-line input voltage: 100 VAC to 127 VAC High-line input voltage: 200 VAC to 240 VAC 240 VDC for China
Rated input frequency	50 Hz to 60 Hz
Rated input current	14.5 A at 100 to 127 VAC 14.5 A at 200 to 240 VAC
Maximum rated input power	1290 W at 100 VAC 1279 W at 120 VAC 1275 W at 127 VAC 2551 W at 200 VAC 2549 W at 208 VAC 2541 W at 230 VAC 2539 W at 240 VAC 2541 W at 240 VDC
BTUs per hour	4403 at 100 VAC 4364 at 120 VAC 4349 at 127 VAC 8705 at 200 VAC 8696 at 208 VAC 8671 at 230 VAC 8662 at 240 VAC 8672 at 240 VDC
Power supply output	—
Rated steady-state power	Low-line input voltage: 1200 W at 100 VAC to 127 VAC High-line input voltage: 2400 W at 200 VAC to 240 VAC input
Maximum peak power	1200 W at 100 VAC to 127 VAC 2400 W at 200 VAC to 240 VAC input
Dimensions	—
Height	40.00 mm (1.57 in)
Depth	185.00 mm (7.28 in)
Width	73.50 mm (2.89 in)

Appendix I: Server coolant spill response

Subtopics

[Eye and skin protection](#)

[Server coolant leak](#)

Eye and skin protection

The coolant used in the liquid cooling module is a mixture of purified water and ethylene glycol with additional additives for corrosion resistance. Observe the following when cleaning up a coolant leak:

- The coolant might cause slight temporary eye irritation.
 - To prevent any accidental eye contact with the coolant, use safety glasses with side shields.
 - If eye contact occurs, immediately flush eye with plenty of water. If any discomfort persists, seek medical attention.
- The coolant might cause slight temporary skin irritation.
 - Use hand protection in the form of chemically resistant gloves when cleaning up coolant leak.
 - If gloves are not worn, wash hands with plenty of water after cleanup.

Server coolant leak

Symptom

A spill or leak of the electrically conductive server coolant is detected by iLO and the server has shut down automatically.

Cause

The supply hose of the liquid cooling module is damaged.

Action

Preparing for coolant leak cleanup

1. Have the following items ready for the coolant leak cleanup:
 - Dry paper towels or any absorbent material intended for cleaning up a chemical spill
 - Container to collect the leaked coolant
 - Dry cleanroom wipes
 - Deionized water
2. Read the following safety information:
 - [Rack warnings and cautions](#)
 - [Server warnings and cautions](#)

Assessing the spill

3. Inspect the server room first and determine if the spill has spread to other servers in the same rack.

Removing the server

4. If the server uses a DLC cold plate module, disconnect the DLC hoses from the rack manifolds.
5. If installed, [open the cable management arm](#).

6.  **WARNING**



To reduce the risk of electric shock, make sure that you use the necessary safety equipment compliant with local occupational health and safety code when disconnecting the power cords.

Remove all power:

- a. Disconnect each power cord from the power source.
 - b. Disconnect each power cord from the server.
7. Disconnect all peripheral cables from the server.
 8. Remove the server from the rack.
 9. Place the server on a flat, level work surface.

Locating the spill point

10. Observe proper eye and skin protection.
11. Remove the access panel.
12. Look for any potential contact between the coolant and any of the internal cables and components, especially power connectors.
13. Locate the spill point.
14. Cover the spill point with a dry absorbent material.

Cleaning up the coolant leak

15. Remove the leaky liquid cooling module. Avoid pushing out more coolant during removal.
16. Remove the system board.
17. If the leak has made it to the system board or the chassis, do the following:
 - a. Use a dry absorbent material to clean the coolant leak.
 - b. Wring the absorbed coolant into a container.
 - c. Lightly dampen a cleanroom wipe with deionized water. Wring out any excess water, and gently wipe over areas with coolant residue.
 - d. Ensure that there is no more visible colored coolant or liquid residue.
 - e. Dry the system board in a 70 °C environment for at least 8 hours.
 - f. Confirm that the system board is completely dry before reinstallation.
18. Follow the procedure in the server maintenance and service guide to reinstall the system board.
19. Repeat steps 11–18 on other servers affected by the spill.

Handling waste

20. Fill the container with tap water and dispose of the residue in accordance with local safety requirements.
21. Use plenty of fresh water to clean the container used to collect the leaked coolant.
22. Dispose of used absorbent material and paper towels in accordance with local safety requirements.

Replacing damaged components

23.  **WARNING**

Water and electricity combined pose a significant safety hazard. Hardware electrical components that have been in contact with the spilled coolant might be damaged.

To ensure a functional and safe server operation, identify and replace all damaged components.

Restoring system operation

24.



IMPORTANT

After the spill is properly cleaned up, do not rush to power on the system immediately. Instead, leave the system in Standby Mode first and observe the front panel LEDs after connecting the power cables.

Verify if the system power LED is illuminated. If not, replace the system board.

25. In the iLO web interface or RESTful API, clear the coolant leakage status.

For the detailed procedure, see the iLO 7 user guide (<https://www.hpe.com/support/hpeilodocs-quicklinks>).

26. If the server uses a DLC cold plate module, reconnect the DLC hoses to the rack manifolds.

27. Power on the server.

If the system fails to boot, replace the system board.

Websites

General websites

Single Point of Connectivity Knowledge (SPOCK) Storage compatibility matrix

<https://www.hpe.com/storage/spock>

Product white papers and analyst reports

<https://www.hpe.com/us/en/resource-library>

For additional websites, see [Support and other resources](#).

Product websites

HPE ProLiant Compute DL320 Gen12 user documents

<https://www.hpe.com/info/dl320gen12-docs>

Support and other resources

- [Accessing Hewlett Packard Enterprise Support](#)
- [Accessing updates](#)
- [Remote support](#)
- [Warranty information](#)
- [Regulatory information](#)
- [Documentation feedback](#)

Subtopics

[Accessing Hewlett Packard Enterprise Support](#)

[HPE product registration](#)

[Accessing updates](#)

[Remote support](#)

[Documentation feedback](#)

Accessing Hewlett Packard Enterprise Support

- For live assistance, go to the Contact Hewlett Packard Enterprise Worldwide website:

<https://www.hpe.com/info/assistance>

- To access documentation and support services, go to the Hewlett Packard Enterprise Support Center website:

<https://www.hpe.com/support/hpesc>

Information to collect

- Technical support registration number (if applicable)
- Product name, model or version, and serial number
- Operating system name and version
- Firmware version
- Error messages
- Product-specific reports and logs
- Add-on products or components
- Third-party products or components

HPE product registration

To gain the full benefits of the Hewlett Packard Enterprise Support Center and your purchased support services, add your contracts and products to your account on the HPESC.

- When you add your contracts and products, you receive enhanced personalization, workspace alerts, insights through the dashboards, and easier management of your environment.
- You will also receive recommendations and tailored product knowledge to self-solve any issues, as well as streamlined case creation for faster time to resolution when you must create a case.

To learn how to add your contracts and products, see <https://www.hpe.com/info/add-products-contracts>.

Accessing updates

- Some software products provide a mechanism for accessing software updates through the product interface. Review your product documentation to identify the recommended software update method.
- To download product updates:

Hewlett Packard Enterprise Support Center

<https://www.hpe.com/support/hpesc>

My HPE Software Center

<https://www.hpe.com/software/hpesoftwarecenter>

- To subscribe to eNewsletters and alerts:

<https://www.hpe.com/support/e-updates>

- To view and update your entitlements, and to link your contracts and warranties with your profile, go to the Hewlett Packard Enterprise Support Center More Information on Access to Support Materials page:

<https://www.hpe.com/support/AccessToSupportMaterials>



IMPORTANT

Access to some updates might require product entitlement when accessed through the Hewlett Packard Enterprise Support Center. You must have an HPE Account set up with relevant entitlements.

Remote support

Remote support is available with supported devices as part of your warranty or contractual support agreement. It provides intelligent event diagnosis, and automatic, secure submission of hardware event notifications to Hewlett Packard Enterprise, which initiates a fast and accurate resolution based on the service level of your product. Hewlett Packard Enterprise strongly recommends that you register your device for remote support.

If your product includes additional remote support details, use search to locate that information.

HPE Get Connected

<https://www.hpe.com/services/getconnected>

HPE Tech Care Service

<https://www.hpe.com/services/techcare>

HPE Complete Care Service

<https://www.hpe.com/services/completecure>

Documentation feedback

Hewlett Packard Enterprise is committed to providing documentation that meets your needs. To help us improve the documentation, click the Feedback button on the page of an opened document on the Hewlett Packard Enterprise Support Center portal (<https://www.hpe.com/support/hpesc>). Use this feature to send any errors, suggestions, or comments. This process captures all document information.