

MAXHUB EXT Touch Console

Model: TCP35T

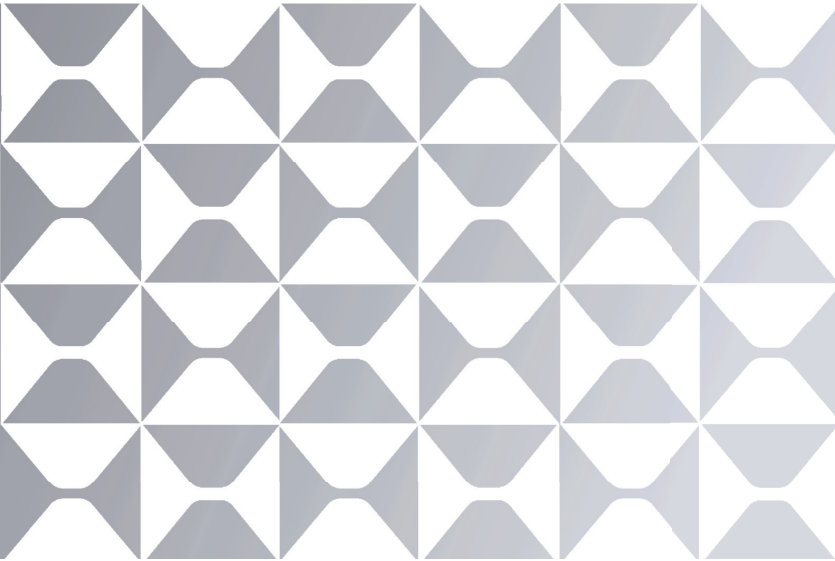

Quick Start Guide

V1.1

MAXHUB

Table of Contents

I. Package Contents	04
II. Product Introduction	05
III. Connection.....	06
IV. Maintenance	07

Thank you for choosing **MAXHUB** product.

To ensure that you are able to fully utilize the capabilities of the product, we ask that you please read this quick start guide carefully and thoroughly before using the device. Should you have any questions or require assistance, please do not hesitate to contact our technical support team for guidance.

Placement

- (1) Please do NOT place the product on a slope, mount on an unstable stand or an insufficiently robust wall, a table nor a shelf.
- (2) Please do NOT expose the product to direct sunlight or any other heat source.
- (3) Please do NOT put the product near devices that generate strong magnetic fields.
- (4) Remove water splashes immediately with a clean dry cloth.
- (5) Please do NOT place any other heavy objects on the product.
- (6) Please do NOT put the unit directly facing an air conditioning vent to avoid condensation inside the glass.

Power Supply

- (1) Please check the product's operating voltage and frequency matches the local power configuration.
- (2) Please unplug the device during storming or thundering weather.
- (3) Please unplug the power should the product is left unused for long time.
- (4) Please keep the power cable from physical or mechanical damage.
- (5) Please use the original power cable from the accessory bag, don't modify or lengthen it.
- (6) Please make sure the AC is grounded.
- (7) This power cable comes with the device exclusively for this device only.
- (8) Please do not abruptly interrupt the power supply or unplug the device while it is powered on to prevent any potential damage.

LCD Screen

- (1) Do NOT use hard nor sharp objects on the screen other than **MAXHUB** stylus.
- (2) Please unplug the power before cleaning the product. Please clean the screen with a soft, dustless and dry cloth.
- (3) Please do NOT use water or liquid detergent to clean the product.
- (4) Please contact the authorised reseller for thorough cleaning.
- (5) Please do NOT display a high-brightness image on the screen for too long time.

Viewing Distance

For optimal viewing experience, it is recommended to position the commercial display at a distance that is 3-4 times the diagonal length of the screen.

Temperature & Humidity

- (1) Please do NOT put the product near a heater nor a radioactive source.
- (2) If the product is moved from a cold place to a warm one, please unplug the power cable and allow the product to gradually warm up for at least two hours to reduce the moisture.
- (3) Operating temperature of the product is 0°C-40°C, operating humidity is between 0%-90%RH.
- (4) avoid exposing the unit to rain or placing it in high humidity areas. Additionally, it is crucial to keep the unit in a dry and cool indoor environment.

Ventilation

Please ensure that the interactive flat panel is placed in an area with adequate ventilation to allow for proper heat dissipation. It is recommended to leave a minimum of 10cm of space on the left, right, and back of the device, and 20cm of space above it to ensure proper airflow and optimal performance.

Earphone

When using the earphones, it is important to be aware that prolonged listening at high volumes may cause temporary or permanent hearing loss. To prevent this, we strongly recommend turning down the volume before inserting the earphones into your ears.

Energy Saving

Please note that simply pressing the power button will not fully shut down the interactive flat panel. Instead, it will enter standby mode, with only the screen turning off. To properly shut down the device, please always select "Shut down" from the Windows Start menu.

Notes for Cleaning

Please do not block or cover the heat vents on the back panel and do not spray liquids on the device. Power Switch Status Signs "I" means power on, "O" means power off.

Maintenance

Please contact authorised reseller for maintenance or repairing.

Warranty Exclusions

MAXHUB does not warranty Products that match any one or few of the following descriptions:

- (1) Product damage caused by violating the user manual.
- (2) Hardware damage caused by improper setup.
- (3) Product damage caused by unauthorised modification or maintenance.
- (4) Product damage caused by using in an unsuitable environment.
- (5) Product damage caused by abnormal external force.
- (6) Product damage caused by natural disasters or other force majeure.
- (7) Damaged Warranty Sticker.
- (8) Unable to provide effective purchase certificate.

More help

For FAQs, technical support, software and user manual download, please visit: www.maxhub.com

I. Package Contents

Please check that the following items are included in the package:

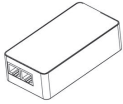

Power Adapter (PoE)

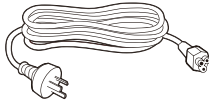

Power Cord x3 (1.8 m / 5.91 ft)



Quick Start Guide x1

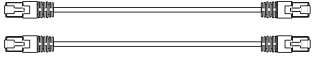

Ethernet Cable x2 (7.5 m / 24.61 feet)

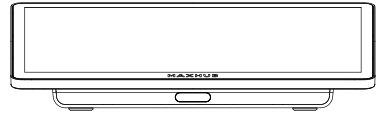

TCP35T Touch Console x1

II. Product Introduction

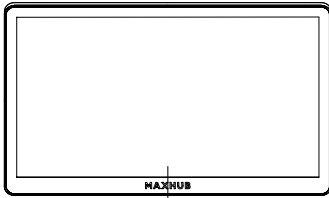

①

Front

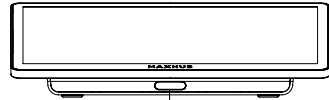

②

Side

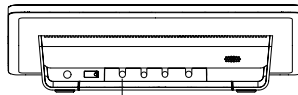

③

Back

No.	Item
1	Touch Screen
2	PIR
3	Ethernet (to master console)

III. Connection

The following diagram shows the connection of EXT TCP35T touch console to the master touch console.

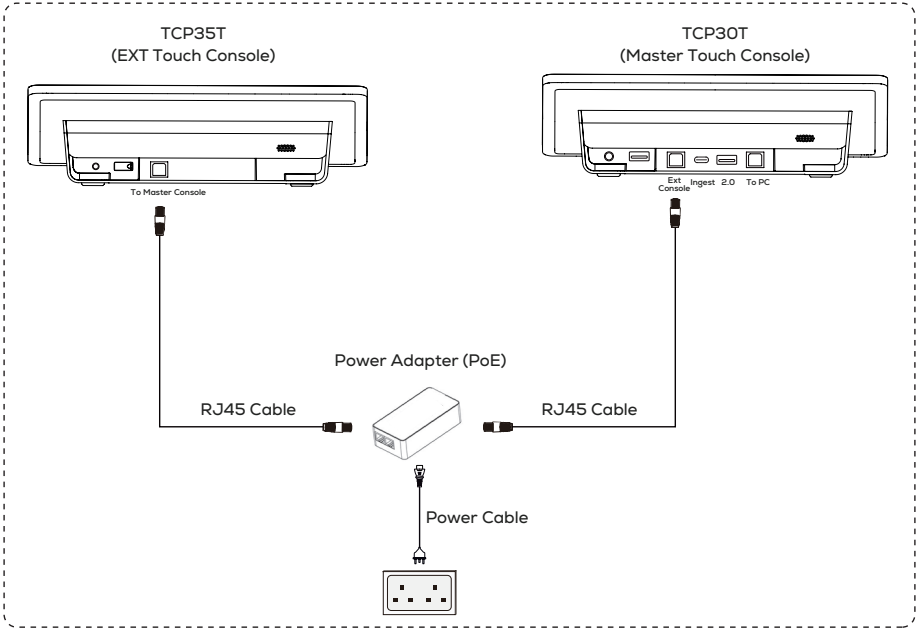

IV. Maintenance

To ensure the proper functioning of the product, it is important to keep it free of dust and moisture. Regular cleaning with a soft, dust-free, and dry cloth is recommended. Remember to unplug the product before cleaning.

Cleaning the Screen

1. Please dissolve the fabric softener or detergent in 75% alcohol.
2. Please use a piece of soft cloth and soak it with the solution.
3. Take out the cloth and squeeze it dry before wiping on the screen.

Cleaning the Touch Frame

Please choose dry, soft and dust-free wipes to clean the touch frame.

Unplug Power

To protect the device during stormy weather or when it will not be in use for an extended period of time, it is recommended to unplug the power.

FCC Statement

This equipment has been tested and found to comply with the limits for a Class B digital device, pursuant to part 15 of the FCC Rules. These limits are designed to provide reasonable protection against harmful interference in a residential installation. This equipment generates,uses and can radiate radio frequency energy and, if not installed and used in accordance with the instructions, may cause harmful interference to radio communications. However, there is no guarantee that interference will not occur in a particular installation. If this equipment does cause harmful interference to radio or television reception, which can be determined by turning the equipment off and on, the user is encouraged to try to correct the interference by one or more of the following measures:

- Reorient or relocate the receiving antenna
- Increase the separation between the equipment and receiver.
- Connect the equipment into an outlet on a circuit different from that to which the receiver is connected
- Consult the dealer or an experienced radio/TV technician for help.

FCC Warning

This device complies with Part 15 of the FCC Rules. Operation is subject to the following two conditions:

- (1) this device may not cause harmful interference, and
- (2) this device must accept any interference received, including interference that may cause undesired operation. Changes or modifications not expressly approved by the party responsible for compliance could void the user's authority to operate the equipment.

Hereby, Guangzhou Shirui Electronics Co., Ltd. declares that the this product is compliant with the essential requirements.

The complete Declaration of Conformity may be requested through the following postal address:
MAXHUB EUROPE B.V.
BEURSPLEIN 37, 3011AA ROTTERDAM, NETHERLANDS

Energy Star Statement

ENERGY STAR is a U.S. Environmental Protection Agency voluntary program that helps businesses and individuals save money and protect our climate through superior energy efficiency. Products that earn the ENERGY STAR prevent greenhouse gas emissions by meeting strict energy efficiency criteria or requirements set by the U.S. Environmental Protection Agency.

The following logo appears on all ENERGY STAR-certified models: This product qualifies for ENERGY STAR in the "Standard mode" setting and this is the setting in which power savings will be achieved. Changing the Standard mode picture settings or enabling other features will increase power consumption that could exceed the limits necessary to qualify for ENERGY STAR rating. Refer to EnergyStar.gov for more information on Energy Star program.



This symbol, affixed to the product or its packaging, indicates that the product must not be processed with household waste. It must be brought to an electric and electronic waste collection point for recycling and disposal. By the appropriate disposal of this product you also help in preventing potentially negative consequences for the environment and human health. The recycling of materials helps preserve our natural resources. For further information regarding the recycling of this product, please contact your municipality, local waste disposal centre or the store where the product was purchased.

