



ExtremeSwitching 5520 Series Hardware Installation Guide

9036817-00 Rev. AN
April 2023



Copyright © 2023 Extreme Networks, Inc. All rights reserved.

Legal Notice

Extreme Networks, Inc. reserves the right to make changes in specifications and other information contained in this document and its website without prior notice. The reader should in all cases consult representatives of Extreme Networks to determine whether any such changes have been made.

The hardware, firmware, software or any specifications described or referred to in this document are subject to change without notice.

Trademarks

Extreme Networks and the Extreme Networks logo are trademarks or registered trademarks of Extreme Networks, Inc. in the United States and/or other countries.

All other names (including any product names) mentioned in this document are the property of their respective owners and may be trademarks or registered trademarks of their respective companies/owners.

For additional information on Extreme Networks trademarks, see: www.extremenetworks.com/company/legal/trademarks

Open Source Declarations

Some software files have been licensed under certain open source or third-party licenses.

End-user license agreements and open source declarations can be found at: <https://www.extremenetworks.com/support/policies/open-source-declaration/>



Table of Contents

Preface.....	vii
Audience.....	vii
Conventions.....	vii
Text Conventions.....	vii
Terminology.....	ix
Providing Feedback.....	ix
Getting Help.....	x
Subscribe to Product Announcements.....	x
Documentation and Training.....	xi
ExtremeSwitching 5520 Series Overview.....	12
Management.....	13
Cooling.....	13
Power Supplies.....	13
Versatile Interface Module Options.....	14
Stacking	14
Operating Temperatures.....	15
Feature Licensing.....	15
5520-24T and 5520-24T-BASE Switch Features.....	15
5520-24W Switch Features.....	16
5520-24X and 5520-24X-BASE Switch Features.....	17
5520-12MW-36W Switch Features.....	18
5520-48T and 5520-48T-BASE Switch Features.....	19
5520-48W Switch Features.....	21
5520-48SE and 5520-48SE-BASE Switch Features.....	22
Port Partitioning.....	24
Power Supplies for Use with Your Switch.....	26
350 W AC Power Supplies.....	26
715 W AC Power Supplies.....	27
1100 W AC Power Supplies.....	27
2000 W AC Power Supply.....	28
Expansion Modules.....	29
V300 Virtual Port Extender.....	30
V300-8P-2X Model.....	30
V300-8T-2X Model.....	31
V300-8P-2T-W Model.....	32
V300HT-8P-2X Model.....	32
V300HT-8T-2X Model.....	33
V300 Virtual Port Extender LEDs.....	35
V400 Virtual Port Extender.....	35
Versatile Interface Modules for the ExtremeSwitching 5520 Series Switches.....	36

5520-VIM-4X Versatile Interface Module.....	38
5520-VIM-4XE Versatile Interface Module.....	38
5520-VIM-4YE Versatile Interface Module.....	39
Site Preparation.....	41
Plan Your Site.....	41
Operating Environment Requirements.....	42
Meet Building and Electrical Codes.....	42
Set up the Wiring Closet.....	43
Control the Temperature.....	44
Control the Humidity Level.....	45
Protect Your System from ESD (Electrostatic Discharge).....	45
Rack Specifications and Recommendations.....	45
Mechanical Recommendations for the Rack.....	46
Ground the Rack.....	46
Provide Adequate Space for the Rack.....	46
Secure the Rack.....	47
Evaluate and Meet Cable Requirements.....	47
Label Cables and Keep Accurate Records.....	48
Install Cable.....	48
Use RJ45 Connector Jackets.....	53
Prevent Radio Frequency Interference (RFI).....	53
Meet Power Requirements.....	54
Requirements for PoE Devices.....	54
Power Supply Requirements.....	54
Requirements for Power Cords.....	54
UPS (Uninterruptible Power Supply) Requirements.....	55
DC Power Requirements.....	56
Follow Applicable Industry Standards.....	56
Build Stacks.....	58
Introduction to Stacking.....	58
Build Basic Stacks.....	59
SummitStack Topologies.....	61
SummitStack Terms.....	64
Plan to Create Your Stack.....	68
Enable and Disable the Stacking-Support Option.....	68
Recommendations for Placing Switches for Stacked Operation.....	68
Recommendations for Configuring Stacks.....	69
Combine Switches from Different Series.....	70
Select Stacking Cables.....	70
Using the Extreme Stacking Tool.....	70
Set up the Physical Stack.....	72
Connect the Switches to Form the Stack Ring.....	72
Connect Your Stack to the Management Network.....	75
Install Your Switch.....	76
Safety Considerations for Installing Switches.....	77
What You Will Need for the Installation.....	77
Attach the Switch to a Rack or Cabinet.....	78
Install Optional Components.....	80

Pluggable Transceiver Modules.....	80
Optical Cables.....	80
Install Internal AC Power Supplies.....	80
Connect Network Interface Cables.....	81
Turn on the Switch.....	81
Activate and Verify the Switch.....	83
Connect the Switch to a Management Console.....	83
Log in for the First Time on Switch Engine.....	83
Configure the Switch's IP Address for the Management VLAN.....	85
Change the Switch OS via the Bootloader Menu.....	85
Change the Switch OS via the Startup Menu.....	86
Log In for the First Time on Fabric Engine.....	86
Install Expansion Modules.....	88
Install a V300 Virtual Port Extender.....	88
Install a V300 Virtual Port Extender on a Wall.....	89
Install a V300 Virtual Port Extender Under or on a Table Surface	92
Install a V300 Virtual Port Extender in a VESA Mount.....	94
Install a V300 in a Single Rack Mount.....	96
Install a V300 in a Dual Rack Mount.....	99
Install a V300 in a DIN Rail Mount.....	102
Install a V300-8P-2T-W Model in a Single or Dual Rack Mount.....	105
Installing a V300-8P-2T-W Model in a DIN Rail Mount.....	106
Connecting the V300 Virtual Port Extender to Power.....	108
Install a V400 Virtual Port Extender.....	109
Install a Half-Duplex to Full-Duplex Converter.....	110
Installing Half-Duplex to Full-Duplex Converters in a 3-Slot Modular Shelf.....	110
Mounting a Half-Duplex to Full-Duplex Converter on a Flat Surface.....	110
Mounting a Half-Duplex to Full-Duplex Converter on a Wall.....	111
Connecting a Half-Duplex to Full-Duplex Converter to its Power Adapter.....	111
Install a Versatile Interface Module in a 5520 Series Switch.....	112
Replace Internal AC Power Supplies.....	114
Replace a 350 W or 715 W AC Power Supply.....	114
Replace an 1100 W AC Power Supply.....	116
Replace a 2000 W AC Power Supply.....	118
Replace Fan Modules.....	121
Pre-Installation Requirements.....	121
Airflow Direction Requirements.....	121
Replace a Fan Module.....	122
Monitor the Device.....	124
5520 Series Switch LEDs.....	124
Port LEDs in Default (SYS) Mode.....	125
Port LEDs in SPD Mode.....	125
Port LEDs in STK Mode.....	126
Versatile Interface Modules (VIM) Port LEDs.....	126
5520-VIM Port LEDs in Default (SYS) Mode.....	127
5520-VIM Port LEDs in SPD Mode.....	127
Technical Specifications.....	128

ExtremeSwitching 5520 Series Technical Specifications.....	129
Fan and Accoustic Noise.....	130
Fan Speed and Temperature Variation	130
Power Options.....	131
Mean Time Between Failures (MTBF).....	133
CPU and Memory.....	134
Standards and Environmental Data.....	134
V300 Virtual Port Extender Specifications.....	136
Power Specifications.....	137
Standards and Environmental Data.....	138
V400 Virtual Port Extender Technical Specifications.....	139
Power Specifications.....	140
Fan and Acoustic Sound.....	141
Standards and Environmental Data.....	142
Half-Duplex to Full-Duplex Converter Technical Specifications.....	142
Half-Duplex to Full-Duplex Converter Power Specifications.....	143
Half-Duplex to Full-Duplex Converter Environmental Data and Standards.....	144
350 W AC Power Supplies Technical Specifications.....	145
715 W AC Power Supplies Technical Specifications.....	146
1100 W AC Power Supplies Technical Specifications.....	146
AC Power Supplies.....	146
2000 W AC Power Supply Technical Specifications.....	148
Power Cord Requirements for AC-Powered Switches and AC Power Supplies.....	148
Console Connector Pinouts.....	149
Safety and Regulatory Information.....	152
Considerations Before Installing.....	153
General Safety Precautions.....	153
Maintenance Safety.....	154
Fiber Optic Ports and Optical Safety.....	154
GBIC, SFP (Mini-GBIC), QSFP+, XENPAK, and XFP Regulatory Compliance.....	155
Cable Routing for LAN Systems.....	155
Installing Power Supply Units and Connecting Power.....	156
Selecting Power Supply Cords.....	157
Battery Notice.....	157
Battery Warning - Taiwan.....	158
EMC Warnings.....	158
Taiwan BSMI Warning.....	158
China CQC Warning.....	158
Japan (VCCI Class A).....	159
Korea EMC Statement.....	159
Index.....	161
Glossary.....	160



Preface

Read the following topics to learn about:

- The meanings of text formats used in this document.
- Where you can find additional information and help.
- How to reach us with questions and comments.

Audience

This guide is intended for use by network administrators responsible for installing and setting up network equipment. It assumes a basic working knowledge of:

- Local area networks (LANs)
- Ethernet concepts
- Ethernet switching and bridging concepts
- Routing concepts
- Simple Network Management Protocol (SNMP)
- Basic equipment installation procedures

See the [Switch Engine 32.1 User Guide](#) and the [Switch Engine 32.1 Command Reference Guide](#) for information about configuring ExtremeSwitching switches.



Note

If the information in an installation note or release note shipped with your Extreme Networks equipment differs from the information in this guide, follow the installation or release note.

Conventions

This section discusses the conventions used in this guide.

Text Conventions

Unless otherwise noted, information in this document applies to all supported environments for the products in question. Exceptions, like command keywords associated with a specific software version, are identified in the text.

When a feature, function, or operation pertains to a specific hardware product, the product name is used. When features, functions, and operations are the same across an entire product family, such as ExtremeSwitching switches or SLX routers, the product is referred to as *the switch* or *the router*.

Table 1: Notes and warnings





Icon	Notice type	Alerts you to...
	Tip	Helpful tips and notices for using the product
	Note	Useful information or instructions
	Important	Important features or instructions
	Caution	Risk of personal injury, system damage, or loss of data
	Warning	Risk of severe personal injury

Table 2: Text

Convention	Description
screen displays	This typeface indicates command syntax, or represents information as it is displayed on the screen.
The words <i>enter</i> and <i>type</i>	When you see the word <i>enter</i> in this guide, you must type something, and then press the Return or Enter key. Do not press the Return or Enter key when an instruction simply says <i>type</i> .
Key names	Key names are written in boldface, for example Ctrl or Esc . If you must press two or more keys simultaneously, the key names are linked with a plus sign (+). Example: Press Ctrl+Alt+Del
<i>Words in italicized type</i>	Italics emphasize a point or denote new terms at the place where they are defined in the text. Italics are also used when referring to publication titles.
NEW!	New information. In a PDF, this is searchable text.

Table 3: Command syntax

Convention	Description
bold text	Bold text indicates command names, keywords, and command options.
<i>italic text</i>	Italic text indicates variable content.

Table 3: Command syntax (continued)

Convention	Description
[]	Syntax components displayed within square brackets are optional. Default responses to system prompts are enclosed in square brackets.
{ x y z }	A choice of required parameters is enclosed in curly brackets separated by vertical bars. You must select one of the options.
x y	A vertical bar separates mutually exclusive elements.
< >	Nonprinting characters, such as passwords, are enclosed in angle brackets.
...	Repeat the previous element, for example, <i>member</i> [<i>member</i> ...].
\	In command examples, the backslash indicates a “soft” line break. When a backslash separates two lines of a command input, enter the entire command at the prompt without the backslash.

Terminology

When features, functionality, or operation is specific to a switch family, such as ExtremeSwitching, the family name is used. Explanations about features and operations that are the same across all product families simply refer to the product as the *switch*.

Providing Feedback

The Information Development team at Extreme Networks has made every effort to ensure the accuracy and completeness of this document. We are always striving to improve our documentation and help you work better, so we want to hear from you. We welcome all feedback, but we especially want to know about:

- Content errors, or confusing or conflicting information.
- Improvements that would help you find relevant information in the document.
- Broken links or usability issues.

If you would like to provide feedback, you can do so in three ways:

- In a web browser, select the feedback icon and complete the online feedback form.
- Access the feedback form at <https://www.extremenetworks.com/documentation-feedback/>.
- Email us at documentation@extremenetworks.com.

Provide the publication title, part number, and as much detail as possible, including the topic heading and page number if applicable, as well as your suggestions for improvement.

Getting Help

If you require assistance, contact Extreme Networks using one of the following methods:

Extreme Portal

Search the GTAC (Global Technical Assistance Center) knowledge base; manage support cases and service contracts; download software; and obtain product licensing, training, and certifications.

The Hub

A forum for Extreme Networks customers to connect with one another, answer questions, and share ideas and feedback. This community is monitored by Extreme Networks employees, but is not intended to replace specific guidance from GTAC.

Call GTAC

For immediate support: (800) 998 2408 (toll-free in U.S. and Canada) or 1 (408) 579 2826. For the support phone number in your country, visit: www.extremenetworks.com/support/contact

Before contacting Extreme Networks for technical support, have the following information ready:

- Your Extreme Networks service contract number, or serial numbers for all involved Extreme Networks products
- A description of the failure
- A description of any actions already taken to resolve the problem
- A description of your network environment (such as layout, cable type, other relevant environmental information)
- Network load at the time of trouble (if known)
- The device history (for example, if you have returned the device before, or if this is a recurring problem)
- Any related RMA (Return Material Authorization) numbers

Subscribe to Product Announcements

You can subscribe to email notifications for product and software release announcements, Field Notices, and Vulnerability Notices.

1. Go to [The Hub](#).
2. In the list of categories, expand the **Product Announcements** list.
3. Select a product for which you would like to receive notifications.
4. Select **Subscribe**.
5. To select additional products, return to the **Product Announcements** list and repeat steps 3 and 4.

You can modify your product selections or unsubscribe at any time.

Documentation and Training

Find Extreme Networks product information at the following locations:

[Current Product Documentation](#)

[Release Notes](#)

[Hardware and software compatibility](#) for Extreme Networks products

[Extreme Optics Compatibility](#)

[Other resources](#) such as white papers, data sheets, and case studies

Extreme Networks offers product training courses, both online and in person, as well as specialized certifications. For details, visit www.extremenetworks.com/education/.



ExtremeSwitching 5520 Series Overview

[5520-24T and 5520-24T-BASE Switch Features](#) on page 15

[5520-24W Switch Features](#) on page 16

[5520-24X and 5520-24X-BASE Switch Features](#) on page 17

[5520-12MW-36W Switch Features](#) on page 18

[5520-48T and 5520-48T-BASE Switch Features](#) on page 19

[5520-48W Switch Features](#) on page 21

[5520-48SE and 5520-48SE-BASE Switch Features](#) on page 22

The ExtremeSwitching 5520 Series is a family of high-performance aggregation switches. The 5520 Series universal hardware provides end-to-end secure network segmentation, in addition to advanced policy capabilities, and offers a user-selectable choice of Extreme's flagship switch operating systems.

The 5520 Series includes 24- and 48-port 1 Gigabit models, 1/2.5/5 Gigabit multi-rate models, as well as a 24-port 10 Gigabit model. The family also offers 30/60/90W PoE, and supports 10G and 25G modular uplinks for flexible linkage to other switches or devices over a range of media.

The 10/100/1000Base-T ports on the 5520-24W/12MW-36W/48T/48W models can operate in half-duplex mode when operating at 10Mbps or 100Mbps. Half-duplex is not supported on these ports when operating at 1Gbps.

Both front-to-back and back-to-front airflow options for fan modules and power supply units are available in 5520 Series switches. All fan modules must have the same airflow direction and must match the airflow direction of the power supplies.

The 5520 Series includes the following models:

- [5520-24T and 5520-24T-BASE Switch Features](#) on page 15
- [5520-24W Switch Features](#) on page 16
- [5520-24X and 5520-24X-BASE Switch Features](#) on page 17
- [5520-12MW-36W Switch Features](#) on page 18
- [5520-48T and 5520-48T-BASE Switch Features](#) on page 19
- [5520-48W Switch Features](#) on page 21
- [5520-48SE and 5520-48SE-BASE Switch Features](#) on page 22

Management

An RJ45 serial console port on the rear panel of the 5520 Series switch enables you to connect a terminal and perform local management. An Ethernet management port can be used to connect the system to a out of band management network for administration. Alternatively, you can use an Ethernet cable to connect this port directly to a laptop to view and locally manage the switch configuration. The Ethernet management port supports 10/100/1000 Mbps speeds.

There is one Micro-B USB console port on the front panel. If the Micro-B USB console port is connected, it will be selected over the RJ45 console port. The Micro-B USB console port will disconnect when the switch is rebooted. You can re-connect the port if needed. When the Micro-B USB console is active, any messages from the switch to the client terminal will be echoed to both the USB console and the rear panel RJ45 serial port; however, no user input will be accepted from the rear panel port.



Tip

Using a Micro-USB Type B to USB Type A cable, connect the Micro-USB Type B end to the switch, and the USB Type A end to a laptop or PC and complete the driver installation steps.

There are also two USB 2.0 Type A ports: one on the front panel labeled USB 1 and one on the rear labeled USB 2. They can be used for a bluetooth dongle or for attaching a removable memory module.



Note

The first USB storage device inserted will be mounted and can be used under the operating system as `/usr/local/ext`. A second inserted USB storage device will not be used until the first one is removed.

Cooling

Switch cooling is provided by replaceable fan modules. Most 5520 Series models have fan modules that use airflow from front-to back. Models 5520-24T-BASE, 5520-24X-BASE, 5520-48T-BASE, and 5520-48SE-BASE require fan modules that use airflow from back-to-front. Power supplies also have integrated cooling fans that operate independently of the switch fan. All installed fan modules must blow air in the same direction and must match the airflow direction of the installed power supplies.

Fans are ordered separately for models 5520-24T-BASE, 5520-24X-BASE, 5520-48T-BASE, and 5520-48SE-BASE. Fans are included with other models.

Two spare fan modules, (17115) with front-to-back airflow, and (X870-FANBF, 17116) with back-to-front airflow, are available for 5520 Series switches.

Power Supplies

Two power supply bays accommodate AC power supplies. Power supplies have integrated cooling fans that operate independently of the switch fans. Like the fan modules, the power supplies are available in models with front-to-back or back-to-front

cooling airflow. All installed power supplies must blow air in the same direction and must match the airflow direction of the installed fan modules.

Power supplies are ordered separately. For more information about the power supplies used in the 5520 Series switches, see [Power Supplies for Use with Your Switch](#) on page 26.

Versatile Interface Module Options

The following Versatile Interface Module (VIM) are available for 5520 Series switches:

- 5520-VIM-4X versatile interface module that provides four 10-GbE (SFP+) ports.
- 5520-VIM-4XE versatile interface module that provides four 10-GbE (SFP+) ports, LRM/MACsec capable.
- 5520-VIM-4YE versatile interface module that provides four 25-GbE (SFP28) MACsec capable ports.



Warning

The switch must be powered off before you install any VIM options. The interface module options are not hot swappable.

Stacking

Each 5520 unit comes equipped with two 40GbE stacking ports, also referred to as Universal Ethernet ports. When running Switch Engine, up to eight systems can be stacked using qualified QSFP28 and QSFP+ direct attach cables and optical transceivers located on the front panel of the switch. Standard 40 Gb Ethernet Optics and passive and active cables can be used in the QSFP28 ports for stacking 5520s together using SummitStack-V160.

High-speed 200Gb stacking is available on 5520 Series switches starting with Switch Engine 31.6 while using SummitStack V-200. The two QSFP ports on the 5520 Series each provide 50Gb in both directions, resulting in 4x50Gb, or 200Gb total. 5520 Series switches can stack only with themselves if you use SummitStack-V200.

When running Fabric Engine, the stacking (or Universal Ethernet) ports are reserved for use by advanced features on the switch by default. For more information, see the advanced-feature-bandwidth-reservation Boot Flag documentation in the *Fabric Engine User Guide* for your version of the Fabric Engine operating system located at <http://documentation.extremenetworks.com/FABRICENGINE/SW/86/FabricEngineUserGuide/>.

Stacking cables for 5520 switches are ordered separately.

For information about QSFP28 and QSFP+ optical modules, see the [Extreme Optics](#) website.

Operating Temperatures

5520 switch models with front-to-back airflow support an operating range from 0°C to 50°C. Switch models with back-to-front airflow support an operating range from 0°C to 45°C. Temperature restrictions apply for some models at high altitudes.

Feature Licensing

The ExtremeSwitching 5520 Series switches support Unified Licensing, so that you can use them with multiple operating systems. There are two methods of acquiring feature licenses: manual or through ExtremeCloud IQ™ (XIQ).

For Switch Engine licensing, see the *Feature License Requirements* for your version of the Switch Engine software located at <https://www.extremenetworks.com/support/documentation/product-type/software/>.

For Fabric Engine licensing, see the *Fabric Engine User Guide* for your version of the Fabric Engine operating system located at <http://documentation.extremenetworks.com/FABRICENGINE/SW/86/FabricEngineUserGuide/>.

For XIQ licensing, see [Licensing Information](#).

5520-24T and 5520-24T-BASE Switch Features

The front panel of the 5520-24T and 5520-24T-BASE switch includes:

- 24 10/100/1000Mb full/half duplex MACsec capable ports



Note

Half-duplex is not supported on these ports when operating at 1Gbps.

- 1 VIM slot
- 1 Type-A USB port
- 1 Micro-B USB console port
- 2 Stacking (Universal Ethernet)/QSFP28 ports

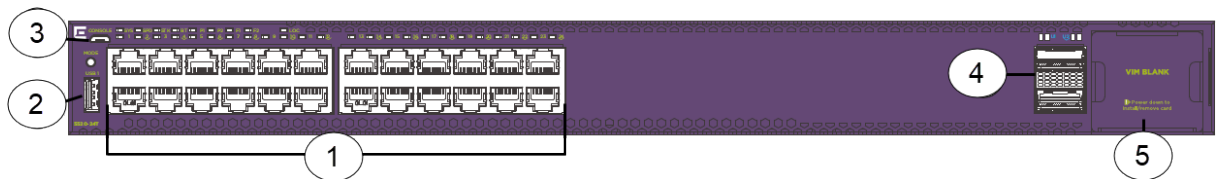

Figure 1: 5520-24T and 5520-24T-BASE Front Panel

1 = 10/100/1000Mb ports	3 = Micro-B USB console port	5 = VIM port (covered)
2 = USB 1 port	4 = Stacking/QSFP28 ports	

The rear panel of the switch includes:



Note

Power supplies and fans are not included with the 5520-24T-BASE model. They must be ordered separately. The 5520-24T-BASE model supports fan modules and power supply units with either front-to-back or back-to-front airflow.

- 2 fan module slots
- Grounding lug
- 1 Type-A USB port
- 2 power supply slots

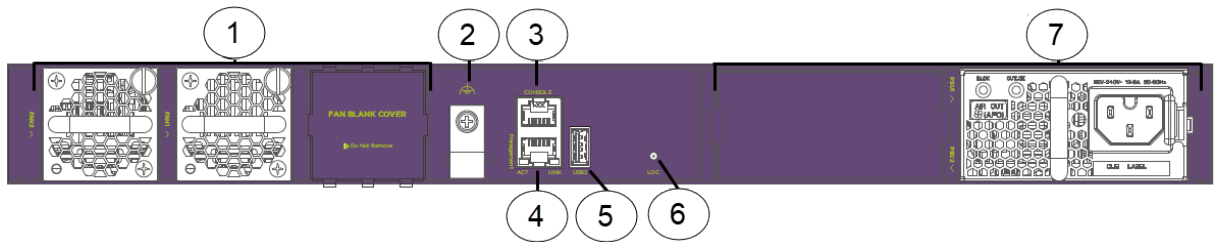

Figure 2: 5520-24T and 5520-24T-BASE Rear Panel

1 = Fan module slots	3 = Serial console port	5 = USB 2 port
2 = Grounding lug	4 = OOB management port	6 = Locator LED
7 = Power supply slots		

5520-24W Switch Features

The front panel of the 5520-24W switch includes:

- 24 10/100/1000Mb full/half duplex MACsec capable ports with 802.3bt Type 4 PoE (90W)



Note

Half-duplex is not supported on these ports when operating at 1Gbps.

- 1 VIM slot
- 1 Type-A USB port
- 1 Micro-B USB console port
- 2 Stacking (Universal Ethernet)/QSFP28 ports

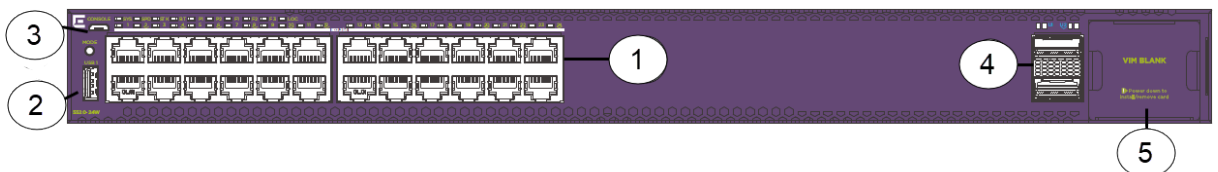

Figure 3: 5520-24W Front Panel

1 = 10/100/1000Mb ports	3 = Micro-B USB console port	5 = VIM port (covered)
2 = USB 1 port	4 = Stacking/QSFP28 ports	

The rear panel of the switch includes:

- 3 fan modules
- Grounding lug
- 1 Type-A USB port
- 2 power supply slots

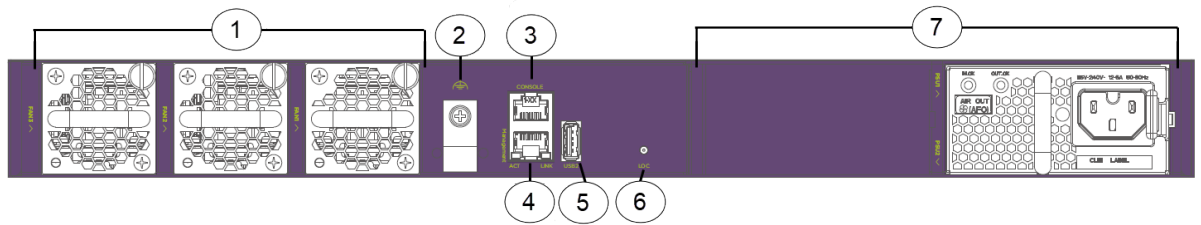

Figure 4: 5520-24W Rear Panel

1 = Fan modules	3 = Serial console port	5 = USB 2 port
2 = Grounding lug	4 = OOB management port	6 = Locator LED
7 = Power supply slots		

5520-24X and 5520-24X-BASE Switch Features

The front panel of the 5520-24X and 5520-24X-BASE switch includes:

- 24 100Mb/1Gb/10Gb SFP+ ports
- 1 VIM slot
- 1 Type-A USB port
- 1 Micro-B USB console port
- 2 Stacking (Universal Ethernet)/QSFP28 ports



Note

5520-24X and 5520-24X-BASE switches do not support 10G LRM and ZR optics.



Figure 5: 5520-24X and 5520-24X-BASE Front Panel

1 = 1GB/10Gb SFP+ ports	3 = Micro-B USB console port	5 = VIM port (covered)
2 = USB 1 port	4 = Stacking/QSFP28 ports	

The rear panel of the switch includes:



Note

Power supplies and fans are not included with the 5520-24X-BASE model. They must be ordered separately. The 5520-24X-BASE model supports fan modules and power supply units with either front-to-back or back-to-front airflow.

- 2 fan modules
- Grounding lug
- 1 Type-A USB port
- 2 power supply slots

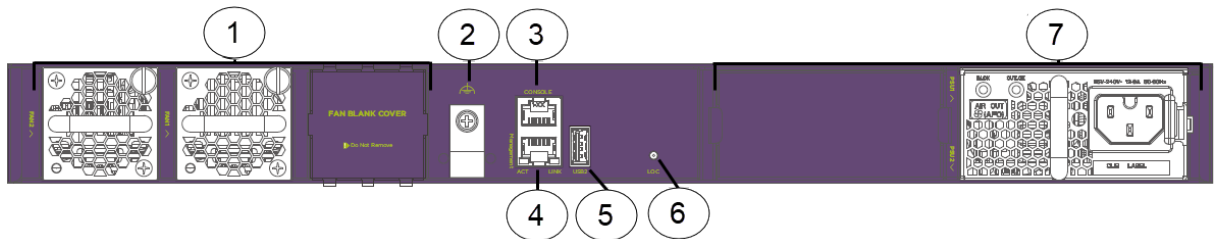

Figure 6: 5520-24X and 5520-24X-BASE Rear Panel

1 = Fan module slots	3 = Serial console port	5 = USB 2 port
2 = Grounding lug	4 = OOB management port	6 = Locator LED
7 = Power supply slots		

5520-12MW-36W Switch Features

The front panel of the 5520-12MW-36W switch includes:

- 12 100Mb/1/2.5/5Gb multi-rate MACsec capable ports
- 36 10/100/1000Mb full/half duplex MACsec capable ports with 802.3bt Type 4 PoE (90W)



Note

Half-duplex is not supported on these ports when operating at 1Gbps or higher.

- 1 VIM slot
- 1 Type-A USB port
- 1 Micro-B USB console port
- 2 Stacking (Universal Ethernet)/QSFP28 ports



Figure 7: 5520-12MW-36W Front Panel

1 = 10/100/1000Mb ports	3 = Micro-B USB console port	5 = VIM port (covered)
2 = USB 1 port	4 = Stacking/QSFP28 ports	6 = 100Mb/1/2.5/5Gb multi-rate ports

The rear panel of the switch includes:

- 3 fan modules
- Grounding lug
- 1 Type-A USB port
- 2 power supply slots

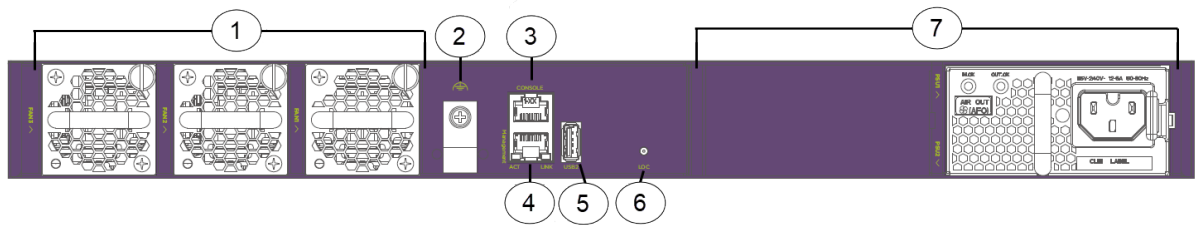

Figure 8: 5520-12MW-36W Rear Panel

1 = Fan modules	3 = Serial console port	5 = USB 2 port
2 = Grounding lug	4 = OOB management port	6 = Locator LED
7 = Power supply slots		

5520-48T and 5520-48T-BASE Switch Features

The front panel of the 5520-48T and 5520-48T-BASE switch includes:

- 48 10/100/1000Mb full/half duplex MACsec capable ports



Note

Half-duplex is not supported on these ports when operating at 1Gbps.

- 1 VIM slot
- 1 Type-A USB port

- 1 Micro-B USB console port
- 2 Stacking (Universal Ethernet)/QSFP28 ports

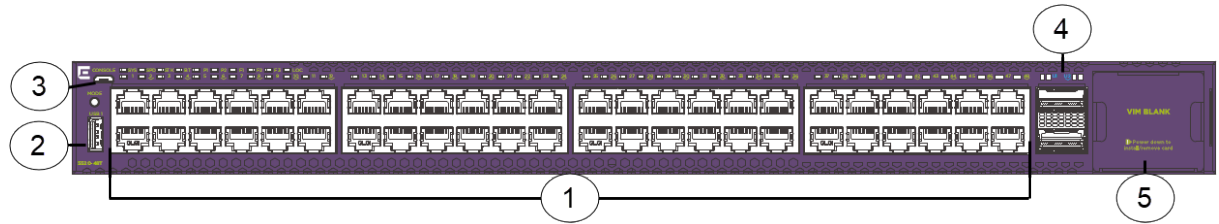

Figure 9: 5520-48T and 5520-48T-BASE Front Panel

1 = 10/100/1000Mb ports	3 = Micro-B USB console port	5 = VIM port (covered)
2 = USB 1 port	4 = Stacking/QSFP28 ports	

The rear panel of the switch includes:



Note

Power supplies and fans are not included with the 5520-48T-BASE model. They must be ordered separately. The 5520-48T-BASE model supports fan modules and power supply units with either front-to-back or back-to-front airflow.

- 3 fan modules
- Grounding lug
- 1 Type-A USB port
- 2 power supply slots

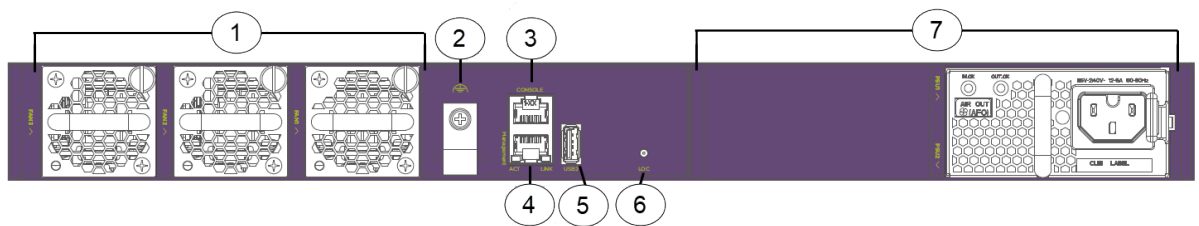

Figure 10: 5520-48T and 5520-48T-BASE Rear Panel

1 = Fan modules	3 = Serial console port	5 = USB 2 port
2 = Grounding lug	4 = OOB management port	6 = Locator LED
7 = Power supply slots		

5520-48W Switch Features

The front panel of the 5520-48W switch includes:

- 48 10/100/1000Mb full/half duplex MACsec capable ports with 802.3bt Type 4 PoE (90W)



Note

Half-duplex is not supported on these ports when operating at 1Gbps.

- 1 VIM slot
- 1 Type-A USB port
- 1 Micro-B USB console port
- 2 Stacking (Universal Ethernet)/QSFP28 ports

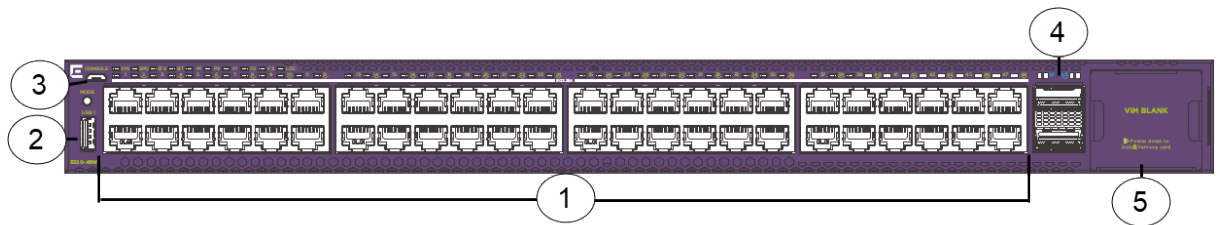

Figure 11: 5520-48W Front Panel

1 = 10/100/1000Mb ports	3 = Micro-B USB console port	5 = VIM port (covered)
2 = USB 1 port	4 = Stacking/QSFP28 ports	

The rear panel of the switch includes:

- 3 fan modules
- Grounding lug
- 1 Type-A USB port
- 2 power supply slots

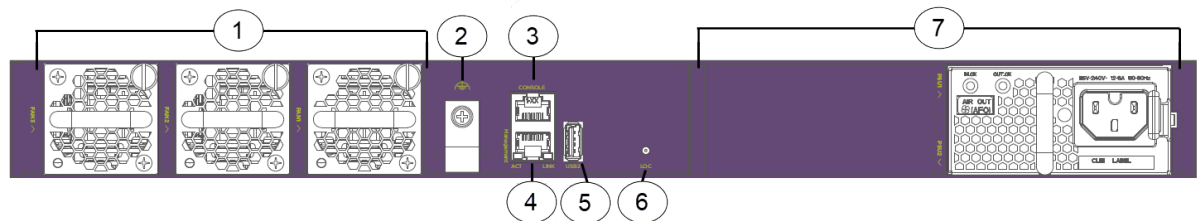

Figure 12: 5520-48W Rear Panel

1 = Fan modules	3 = Serial console port	5 = USB 2 port
2 = Grounding lug	4 = OOB management port	6 = Locator LED

7 = Power supply slots

5520-48SE and 5520-48SE-BASE Switch Features

The front panel of the 5520-48SE and 5520-48SE-BASE switch includes:

- 48 100/1000BASE-X MACsec capable SFP ports
- 1 VIM slot
- 1 Type-A USB port
- 1 Micro-B USB console port
- 2 Stacking (Universal Ethernet)/QSFP28 ports

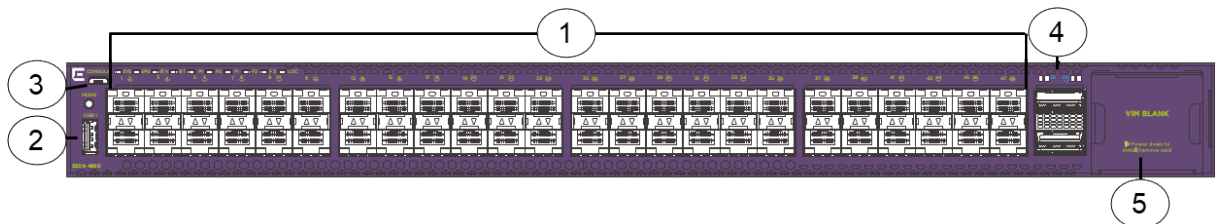

Figure 13: 5520-48SE F5520-48SE-BASE front Panel

1 = 100/1000BASE-X MACsec capable SFP ports	3 = Micro-B USB console port	5 = VIM port (covered)
2 = USB 1 port	4 = Stacking/QSFP28 ports	

The rear panel of the switch includes:



Note

Power supplies and fans are not included with the 5520-48SE-BASE model. They must be ordered separately. The 5520-48SE-BASE model supports fan modules and power supply units with either front-to-back or back-to-front airflow.

- 3 fan modules
- Grounding lug
- 1 Type-A USB port
- 2 power supply slots

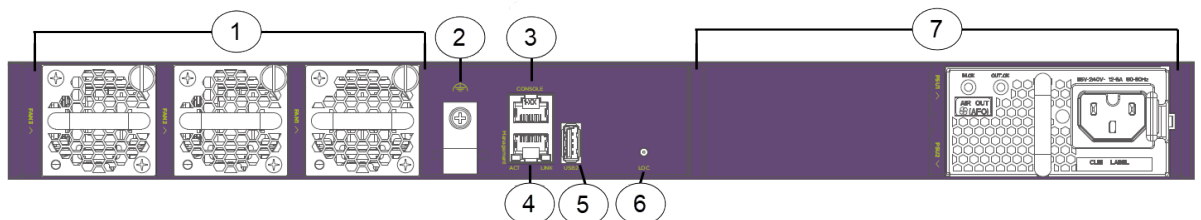

Figure 14: 5520-48SE 5520-48SE-BASE Rear Panel

1 = Fan module slots	3 = Serial console port	5 = USB 2 port
2 = Grounding lug	4 = OOB management port	6 = Locator LED
7 = Power supply slots		



Port Partitioning

On some ExtremeSwitching Universal switch models, you can configure QSFP28 ports either as single ports or as multiple, partitioned ports. In a partitioned port, with appropriate cabling, the original physical port can accommodate multiple data lanes at lower bandwidths.

The following partitioning options are available:

Table 4: QSFP28 Port Partitioning

Switch model	Port bandwidth	Port partitions
5520 (all models) QSFP28	100 Gb	One QSFP28 port with one of the following: <ul style="list-style-type: none"> • Two 50 Gb ports • One 40 Gb port (default) • Four 25 Gb ports • Four 10 Gb ports <p>Note: These ports do not support 1x100Gb</p>
5720 (all models) U1 and U2 ports	100Gb	One U1 or U2 port with one of the following: <ul style="list-style-type: none"> • One 40 Gb port • One 100 Gb port (default) • Two 50 Gb ports • Four 10 Gb ports • Four 25 Gb ports
5720-VIM-6YE	25G	The 5720-VIM-6YE has two speed groups, each with three ports that can be partitioned with the following: <ul style="list-style-type: none"> • Three 1 Gb ports • Three 10 Gb ports • Three 25 Gb ports (default)
5720-VIM-2CE	100G	The 5720-VIM-2CE has two ports, each of which can be partitioned with the following: <ul style="list-style-type: none"> • One 100 Gb port (default) • One 40 Gb port • Four 10 Gb ports • Four 25 Gb ports

For information about configuring partitioned ports, see the [Switch Engine 32.1 Command Reference Guide](#).



Power Supplies for Use with Your Switch

[350 W AC Power Supplies](#) on page 26

[715 W AC Power Supplies](#) on page 27

[1100 W AC Power Supplies](#) on page 27

[2000 W AC Power Supply](#) on page 28

Each 5520 Series switch runs with two replaceable internal power supply units that provide all of the power needed for the switch to operate. You can remove one power supply without interrupting the switch's operation.

Power supplies are ordered separately.

For more information, see the following topics:

- [350 W AC Power Supplies](#) on page 26
- [715 W AC Power Supplies](#) on page 27
- [1100 W AC Power Supplies](#) on page 27
- [2000 W AC Power Supply](#) on page 28

350 W AC Power Supplies

The 350 W AC PSU-FB (models XN-ACPWR-350W-FB and 10953 with front-to-back ventilation airflow) is compatible with 5520-24T, 5520-24T-BASE, 5520-24X, 5520-24X-BASE, 5520-48T, 5520-48T-BASE, 5520-48SE, and 5520-48SE-BASE switch models.

The 350 W AC PSU-BF (models XNACPWR-350W-BF and DPS350AB-42 A with back-to-front ventilation airflow) is compatible with 5520-24T-BASE, 5520-24X-BASE, 5520-48T-BASE, and 5520-48SE-BASE switch models.

The 350 W AC power supply has a keyed power inlet (C13).

The 350 W AC power supply has the status LEDs listed in [Table 5](#).

Table 5: 350 W AC Power Supply LED Status Indications

IN_OK (Green)	OUT_OK (Green or Red)	Description
Off	Off	No AC input power connection or low AC voltage
On	Off	AC input good; output disabled
On	(Red) On	AC input good; output fault
On	(Green) On	AC input good; output good

715 W AC Power Supplies

The 715 W AC PSU-FB (models XN-ACPWR-715W-FB and 10951 with front-to-back ventilation airflow) are compatible with 5520-24W, 5520-12MW-36W, and 5520-48W switch models.

The 715 W AC power supply has a keyed power inlet (C16) that requires a notched (C15) power cord.

The 715 W AC power supply has the status LEDs listed in the following table:

Table 6: 715 W AC Power Supply LED Status Indications

IN_OK (Green)	OUT_OK (Green or Red)	Description
Off	Off	No AC input power connection or low AC voltage.
On	Off	AC input good, 54V output disabled.
On	(Red) On	AC input good, output (54V) fault.
On	(Green) On	AC input good, DC outputs in spec.

1100 W AC Power Supplies

The 1100 W AC PSU-FB (models XN-ACPWR-1100W-FB and 10941 with front-to-back ventilation airflow) are compatible with 5520-24W, 5520-12MW-36W, and 5520-48W switch models.

The 1100 W AC power supply has a keyed power inlet (C16) that requires a notched (C15) power cord.

The 1100 W AC power supply has the status LEDs listed in the following table:

Table 7: 1100 W AC Power Supply LED Status Indications

IN_OK (Green)	OUT_OK (Green or Red)	Description
Off	Off	No AC input power connection or low AC voltage.
On	Off	AC input good, 54V output disabled.
On	(Red) On	AC input good, output (54V) fault.
On	(Green) On	AC input good, DC outputs in spec.

2000 W AC Power Supply

The 2000 W AC PSU-FB (models XN-ACPWR-2000W-FB and XN-ACPWR-2000W-F with front-to-back ventilation airflow) are compatible with 5520-24W, 5520-12MW-36W, and 5520-48W switch models.



Note

In order to obtain 2000W output from this power supply, the PSU must be connected to a 200-240VAC source.

The ExtremeSwitching 2000 W AC power supply has a keyed power inlet (C16) that requires a notched (C15) power cord.

The ExtremeSwitching 2000 W AC power supply has the status LEDs listed in the following table:

Table 8: ExtremeSwitching 2000 W AC Power Supply LED Status Indications

IN_OK (Green)	OUT_OK (Green or Red)	Description
Off	Off	No AC input power connection or low AC voltage.
On	Off	AC input good, 54V output disabled.
On	(Red) On	AC input good, output (54V) fault.
On	(Green) On	AC input good, DC outputs in spec.



Expansion Modules

[V300 Virtual Port Extender](#) on page 30

[V400 Virtual Port Extender](#) on page 35

[Versatile Interface Modules for the ExtremeSwitching 5520 Series Switches](#) on page 36

Several different hardware accessories are available for expanding the capabilities of your Extreme Networks switch. Collectively, they are referred to as *expansion modules*.

- Versatile interface modules (VIM) are installed in one dedicated slot in the front of the switch to provide a dedicated 10/25/40G high speed port. If no module is installed, the option slot is covered by a blank panel.

The following table lists the types of expansion modules and the switch series with which they are compatible.

Table 9: Compatibility of Expansion Modules

Module Type	Name	No. of Ports	Type of Ports
Bridge Port Extender	V300 Virtual Port Extender	up to 8	8 10/100/1000BASE-T ports and: <ul style="list-style-type: none"> • 2 1000BASE-T 802.3bt Type 4 uplink ports for PoE model • 2 10Gb SFP+ uplink ports for non-PoE models
Bridge Port Extender	V400 Virtual Port Extender	up to 48	48 10/100/1000BASE-T ports and: <ul style="list-style-type: none"> • 2 10Gb SFP+ uplink ports for V400-24 port models • 4 10Gb SFP+ uplink ports for V400-48 port models
5520-VIM	5520-VIM-4X	4	10GbE SFP+ optical ports
	5520-VIM-4XE	4	10GbE SFP+ MACsec capable optical ports
	5520-VIM-4YE	4	25GbE SFP28 MACsec capable optical ports

V300 Virtual Port Extender

Bridge port extenders (BPEs) are devices that do not fully process packets, nor make forwarding or filtering decisions. Instead, they simply receive packets from extended ports and forward packets toward the upstream controlling bridge (an Switch Engine-based switch) for L2/L3 processing. This scheme, based on the IEEE 802.1BR specification, is known as extended edge switching.

The V300 Virtual Port Extender offers the following models:

- [V300-8P-2X Model](#) on page 30
- [V300-8T-2X Model](#) on page 31
- [V300-8P-2T-W Model](#) on page 32
- [V300HT-8P-2X Model](#) on page 32
- [V300HT-8T-2X Model](#) on page 33

In general, the V300 Virtual Port Extender offers the following features:

- Eight 10/100/1000BASE-T half/full duplex ports or 10/100/1000BASE-T half/full duplex PoE+ ports
- Two 10Gb SFP+ uplinks
- PoE+ power on some models
- Fixed internal power-supply (non-PoE models), fanless

For more information about configuring Switch Engine for use with this equipment, see the [Switch Engine 32.1 User Guide](#).

V300-8P-2X Model

The Virtual Port Extender V300-8P-2X model offers the following features:

- Eight 10/100/1000BASE-T half/full duplex PoE+ ports
- Two 10Gb SFP+ ports
- One USB port
- One console/management port
- One DC input port

For more information about configuring Switch Engine for use with this equipment, see the [Switch Engine 32.1 User Guide](#).

The V300-8P-2X model is shipped with one 40W AC PS FRU (Model XN-ACPWR-280W).

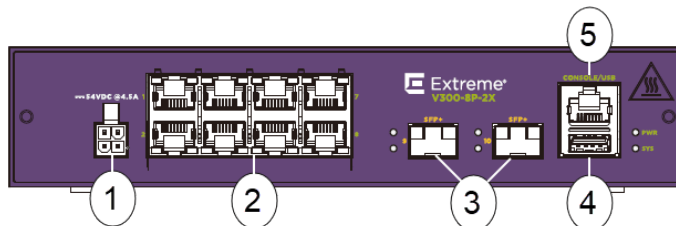

Figure 15: V300-8P-2X Front Panel

1 = DC input	2 = 10/100/1000BASE-T PoE+ ports
3 = 10Gb SFP+ ports	4 = USB port
5 = Console/Management port	

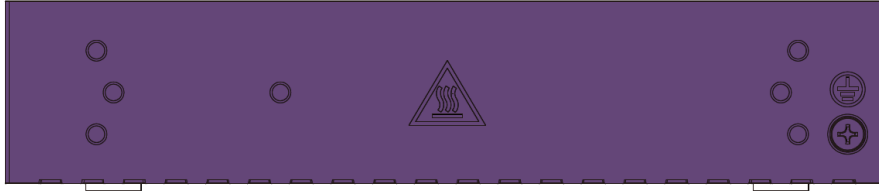

Figure 16: V300 Virtual Port Extender Rear Panel

V300-8T-2X Model

The Virtual Port Extender V300-8T-2X model offers the following features:

- Eight 10/100/1000BASE-T half/full duplex ports
- Two 10Gb SFP+ ports
- One USB port
- One console/management port
- One DC input jack

For more information about configuring Switch Engine for use with this equipment, see the [Switch Engine 32.1 User Guide](#).

The V300-8T-2X model is shipped with one 40W AC PS FRU (Model XN-ACPWR-40W).

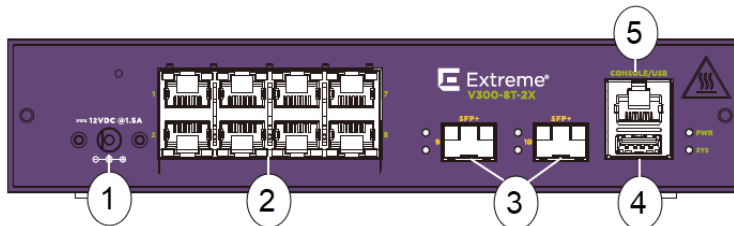

Figure 17: V300-8T-2X Front Panel

1 = DC input	2 = 10/100/1000BASE-T ports
3 = 10Gb SFP+ ports	4 = USB port
5 = Console/Management port	



Figure 18: V300 Virtual Port Extender Rear Panel

V300-8P-2T-W Model

The Virtual Port Extender V300-8P-2T-W model offers the following features:

- 8 10/100/1000BASE-T half duplex PoE+ ports
- 2 1000/BASE-T 802.3bt Type 4 ports
- PoE power
- Fanless

For more information about configuring Switch Engine for use with this equipment, see the [Switch Engine 32.1 User Guide](#).

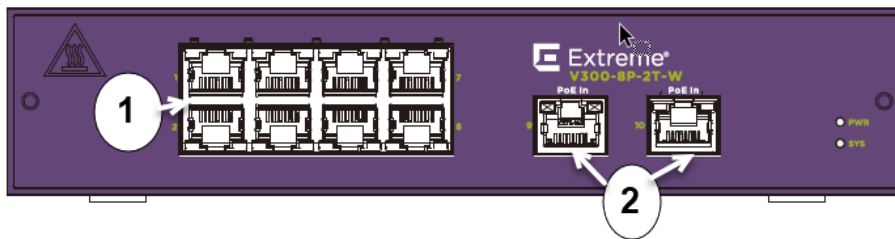

Figure 19: V300-8P-2T-W Front Panel

1 = 10/100/1000BASE-T PoE ports	2 = 1000/BASE-T 802.3bt PD up-link
---------------------------------	------------------------------------



Figure 20: V300-8P-2T-W Rear Panel

V300HT-8P-2X Model

The Virtual Port Extender V300HT-8P-2X model is a high-temperature model that offers the following features:

- Eight 10/100/1000BASE-T half/full duplex PoE+ ports
- Two 10Gb SFP+ ports
- One USB port
- One console/management port
- Two DC input ports

For more information about configuring Switch Engine for use with this equipment, see the [Switch Engine 32.1 User Guide](#).

The V300HT-8P-2X model is compatible with the following power supplies: 40W AC PS FRU (Model XN-ACPWR-40W).

- Model XN-ACPWR-320W-HT - a 320W AC power supply high temperature

- Model 16807 - an IS AC-DC power supply with 240W output and DIN rail compatible



Important

The high temperature power supplies for the V300HT models require field wiring. Power supplies must be installed in accordance with local electrical codes by a licensed electrician.



Note

Power supplies for this model are sold separately.

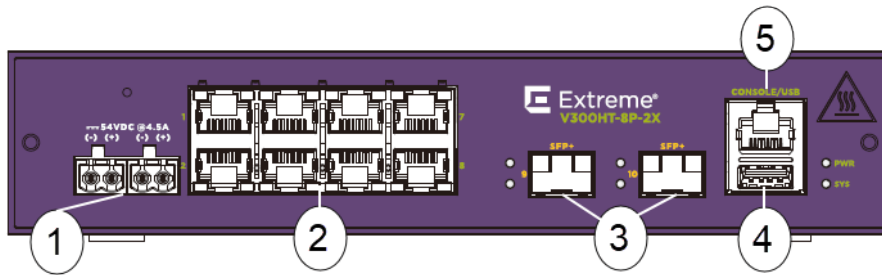

Figure 21: V300HT-8P-2X Front Panel

1 = DC inputs	2 = 10/100/1000BASE-T PoE+ ports
3 = 10Gb SFP+ ports	4 = USB port
5 = Console/Management port	

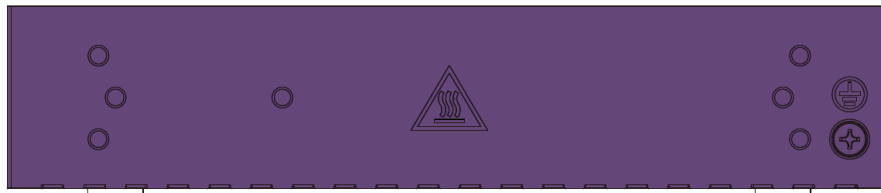

Figure 22: V300 Virtual Port Extender Rear Panel

V300HT-8T-2X Model

The Virtual Port Extender V300HT-8T-2X model is a high-temperature model that offers the following features:

- Eight 10/100/1000BASE-T half/full duplex ports
- Two 10Gb SFP+ ports
- One USB port
- One console/management port
- Two DC input ports

For more information about configuring Switch Engine for use with this equipment, see the [Switch Engine 32.1 User Guide](#).

The V300HT-8T-2X model is compatible with the following power supplies:

- Model XN-ACPWR-40W-HT - a 40W AC power supply high temperature
- Model XN-ACPWR-60W-HT-DIN - a 60W AC power supply high temperature DIN rail compatible



Important

The high temperature power supplies for the V300HT models require field wiring. Power supplies must be installed in accordance with local electrical codes by a licensed electrician.



Note

Power supplies for this model are sold separately.

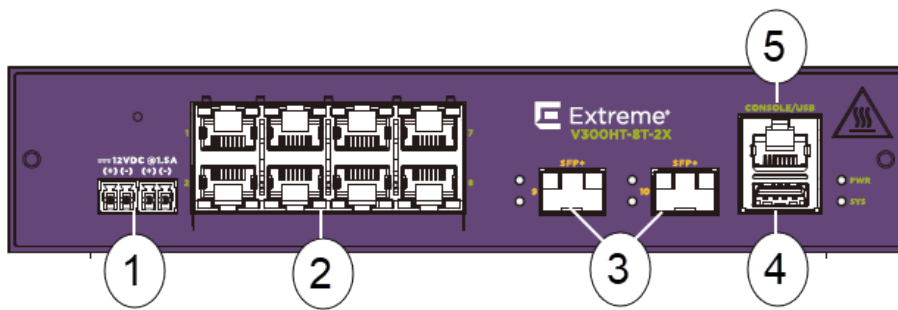

Figure 23: V300HT-8T-2X Front Panel

1 = DC inputs	2 = 10/100/1000BASE-T ports
3 = 10Gb SFP+ ports	4 = USB port
5 = Console/Management port	



Figure 24: V300 Virtual Port Extender Rear Panel

V300 Virtual Port Extender LEDs

The V300 Virtual Port Extender front panel LEDs observe the following behavior:

Table 10: V300 Virtual Port Extender LEDs

Location	LED Indicative	Color	Status	Description
LED Per device	PWR LED (Top)	Green	Off	Power off
			Solid	Power on
		Amber	Solid	External PSU 2 fail (For non-PD model)
			Flash	External PSU 1 fail (For non-PD model)
	System LED (Bottom)	Green	Off	System off
			Solid	System on and ready
			Flash	Booting
		Amber	Flash	Fail (Controlled by MPP)
LED Per RJ45 Port 1-8 (PSE)	Link/Act (left)	Green	Off	No Link
			Solid	Link is established
			Flash	Link activity
	PoE (right)	Amber	Off	No PD detected
			Solid	PD is detected
			Flash	Link activity
LED Per RJ45 Port 9-10 (PD)	Link/Act (left)	Green	Off	No link
			Solid	Link is established
			Flash	Link activity
	PoE (right) PoE model	Amber	Off	No PSE power is provided
			Solid	PSE power is supplied
			Flash	Link activity

V400 Virtual Port Extender

Bridge port extenders (BPEs) are devices that do not fully process packets, nor make forwarding or filtering decisions. Instead, they simply receive packets from extended ports and forward packets toward the upstream controlling bridge (a Switch Engine-based switch) for L2/L3 processing. This scheme, based on the IEEE 802.1BR specification, is known as extended edge switching.

The V400 Virtual Port Extender offers the following features:

- 24 or 48 10/100/1000 Base-T ports that provide 10 Gbps copper connectivity.
- Two or four 1000/10G Base-X SFP+ ports that provide 10 Gbps high-density fiber connectivity.
- Serial console port.
- Front panel USB port.

- PoE+ power on some models.
- Fixed internal power-supply and fan modules.

All models include either two or four SFP+ ports on the faceplate of each base unit, which can be provisioned either as uplink or cascade ports. This gives administrators the option to create redundant links or downstream cascade ports to other V400 units. The SFP+ ports are the only ones that can be used as uplink ports in a cascading configuration.

For more information about configuring Switch Engine for use with this equipment, see the [Switch Engine 32.1 User Guide](#).

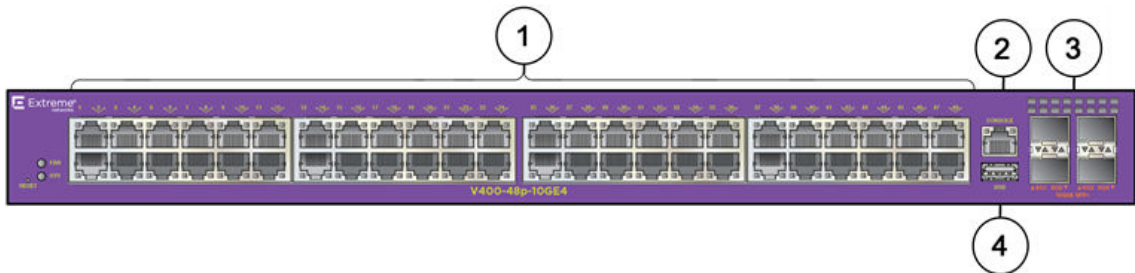

Figure 25: V400 Virtual Port Extender Front Panel (48-port Model Shown)

1 = 10/100/1000BASE-T ports	3 = 10Gb SFP+ ports
2 = Console/management port	4 = USB port

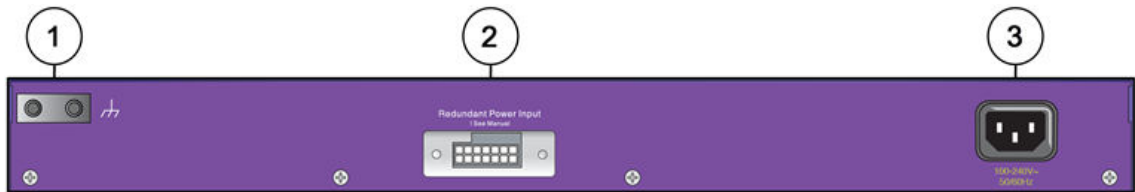

Figure 26: V400 Virtual Port Extender Rear Panel

1 = Grounding lug	3 = AC power input connector
2 = RPS connector (some models)	

Versatile Interface Modules for the ExtremeSwitching 5520 Series Switches

You can install a versatile interface module (VIM) in a dedicated slot in the front panel of the ExtremeSwitching 5520 Series switch to provide 10/25G dedicated high speed ports. The front panel of every 5520 Series switch provides one slot to install the following:

- 5520-VIM-4X versatile interface module that provides four 10-GbE (SFP+) ports.
- 5520-VIM-4XE versatile interface module that provides four 10-GbE (SFP+) ports, LRM/MACsec capable.
- 5520-VIM-4YE versatile interface module that provides four 25-GbE (SFP28) MACsec capable ports.

The 5520-VIM ports are 1-4 on the 5520-VIM faceplate.

In Fabric Engine, the 5520-VIM slot number is 2.

5520-VIMs are ordered separately. Each VIM label can be found on the bottom side of the device, as seen in the following figure:

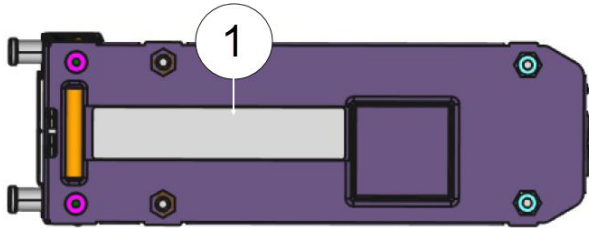

Figure 27: 5520-VIM Label

1 = 5520-VIM label

Table 11: 5520-VIM Matrix

	5520-VIM-4X	5520-VIM-4XE	5520-VIM-4YE
Usable ports	4	4	4
Operational speeds	1Gbps & 10Gbps	1Gbps & 10Gbps	10Gbps & 25Gbps
PHY present	No	Yes	Yes
1000BASE-T & 10GBASE-T	10GBASE-T only	Both	10GBASE-T only
Mixed speeds	1Gbps & 10Gbps	1Gbps & 10Gbps	Not supported ¹
1G Auto-negotiation	Disabled	Enabled	
10G Auto-negotiation	Disabled	Disabled	Disabled
10G LRM & ZT optics	Not supported	Supported	Supported
25G Auto-negotiation			Enabled for DAC Disabled for Fiber
FEC	Not supported	Not supported	Auto-FEC enabled for DAC and Fiber ²
MACsec	Not supported	128/256bit	128/256bit

¹ - In Fabric Engine, you must set `sys vim-speed` to 10G or 25G for 5520-VIM-4YE. The default is 25G. A reboot is not necessary after setting the speed.

¹ - In Switch Engine, use the `configure ports partition` command with 4x25 or 4x10 on the first VIM port.

² - FEC is enabled by default only with `autonegotiation` set to ON.

See [Versatile Interface Modules \(VIM\) Port LEDs](#) on page 126 for VIM LED details.

5520-VIM-4X Versatile Interface Module

The 5520-VIM-4X versatile interface module provides four 10-GbE (SFP+) ports.

For information about the supported optical modules, refer to the most recent version of the [Extreme Optics](#) website.

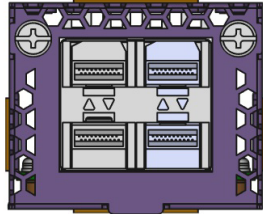

Figure 28: 5520-VIM-4X Versatile Interface Module

Table 12: Port Numbers for Ports on the 5520-VIM-4X Module

5520 Series 24-port models	5520 Series 48-port models	Fabric Engine (all models)
33-36 (Switch Engine)	57-60 on 48-port models (Switch Engine)	VIM slot number=2 Interface names=2/1-2/4

5520-VIM-4XE Versatile Interface Module

The 5520-VIM-4XE versatile interface module provides four 10-GbE (SFP+) ports, MACsec capable.

For information about the supported optical modules, refer to the most recent version of the [Extreme Optics](#) website.

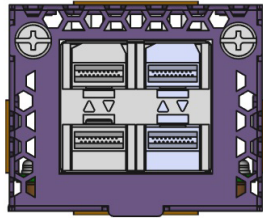

Figure 29: 5520-VIM-4XE Versatile Interface Module

Table 13: Port Numbers for Ports on the 5520-VIM-4XE Module

5520 Series 24-port models	5520 Series 48-port models	Fabric Engine (all models)
33-36 (Switch Engine)	57-60 on 48-port models (Switch Engine)	VIM slot number=2 Interface names=2/1-2/4

5520-VIM-4YE Versatile Interface Module

The 5520-VIM-4YE versatile interface module provides four 25-GbE (SFP28) MACsec capable ports.



Note

In Fabric Engine, you must use the `sys vim-speed` command to set the speed to 10G or 25G for 5520-VIM-4YE. The default is 25G. A reboot is not necessary after setting the speed.

In Switch Engine, use the `configure ports partition` command with 4x25 or 4x10.

For information about the supported optical modules, refer to the most recent version of the [Extreme Optics](#) website.

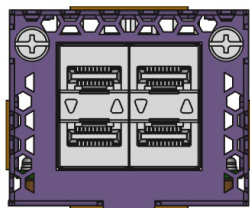

Figure 30: 5520-VIM-4YE Versatile Interface Module

Table 14: Port Numbers for Ports on the 5520-VIM-4YE Module

5520 Series 24-port models	5520 Series 48-port models	Fabric Engine (all models)
33-36 (Switch Engine)	57-60 on 48-port models (Switch Engine)	VIM slot number=2 Interface names=2/1-2/4



Site Preparation

- [Plan Your Site](#) on page 41
- [Operating Environment Requirements](#) on page 42
- [Rack Specifications and Recommendations](#) on page 45
- [Evaluate and Meet Cable Requirements](#) on page 47
- [Meet Power Requirements](#) on page 54
- [Follow Applicable Industry Standards](#) on page 56

By carefully planning your site, you can maximize the performance of your existing network and ensure that it is ready to migrate to future networking technologies.

The information in this chapter is intended for the system administrator, network equipment technician, network manager, or facilities manager responsible for installing and managing the network hardware. The chapter assumes a working knowledge of local area network (LAN) operations, and a familiarity with communications protocols that are used on interconnected LANs.

Only qualified service personnel should install, maintain, or remove a switch, chassis, or its components. Qualified service personnel have had appropriate technical training and experience that is necessary to be aware of the hazards to which they are exposed when performing a task and of measures to minimize the danger to themselves or other people.



Note

Before installing or removing any components of the system, and before carrying out any maintenance procedures, read the safety information in "Technical Specifications."

Plan Your Site

To install your equipment successfully, you should plan the site carefully. The site planning process has three major parts:

1. Meeting site requirements.

The physical installation site must meet the following requirements for a safe and successful installation:

- Building and electrical code requirements
- Environmental, safety, and thermal requirements for the equipment you plan to install

- Equipment rack requirements
2. Evaluating and meeting cable requirements.

After examining your physical site and verifying that all environment requirements are met, evaluate and compare your existing cable plant with the requirements of the Extreme Networks equipment to determine if you need to install new cables.

3. Meeting power requirements.

To run your equipment safely, you must meet the specific power requirements for each switch and external power supply unit installed in the system.

For power specifications of the switches, see the specific switch listings in "Technical Specifications."

Operating Environment Requirements

Verify that your site meets all environmental and safety requirements.

Virtually all areas of the United States are regulated by building codes and standards. During the early planning stages of installing or modifying your network, it is important that you develop a thorough understanding of the regulations that pertain to your location and industry.

Meet Building and Electrical Codes

Building and electrical codes vary depending on your location. Comply with all code specifications when planning your site and installing cable. This section lists resources for obtaining additional information.

For information about major building codes, consult the following organization:

International Code Council (ICC)
5203 Leesburg Pike
Falls Church, VA 22041 USA
www.iccsafe.org

The organizations listed in [Table 15](#) are authorities on electrical codes.

Table 15: Authorities on Electrical Codes

Organization	Address	Web Site URL
National Electrical Code (NEC) Classification (USA only) Recognized authority on safe electrical wiring. Federal, state, and local governments use NEC standards to establish their own laws, ordinances, and codes on wiring specifications. The NEC classification is published by the National Fire Protection Association (NFPA).	NFPA 1 Batterymarch Park Quincy, MA 02169 USA	www.nfpa.org/
Underwriters' Laboratory (UL) Independent research and testing laboratory. UL evaluates the performance and capability of electrical wiring and equipment to determine whether they meet certain safety standards when properly used. Acceptance is usually indicated by the words "UL Approved" or "UL Listed."	UL 333 Pfingsten Road Northbrook, IL 60062 USA	www.ul.com
National Electrical Manufacturing Association (NEMA) (USA only) Organization of electrical product manufacturers. Members develop consensus standards for cables, wiring, and electrical components.	NEMA 1300 N. 17th Street Rosslyn, VA 22209 USA	www.nema.org
Electronic Components Industry Association (ECIA) Trade association that develops technical standards, disseminates marketing data, and maintains contact with government agencies in matters relating to the electronics industry.	ECIA 111 Alderman Drive Suite 400 Alpharetta, GA 30005 USA	www.ecianow.org
Federal Communications Commission (FCC) (USA only) Commission that regulates all interstate and foreign electrical communication systems that originate in the United States according to the Communications Act of 1934. The FCC regulates all U.S. telephone and cable systems.	FCC 445 12th Street S.W. Washington, DC 20554 USA	www.fcc.gov

Set up the Wiring Closet

Be aware of the following recommendations for your wiring closet:

- Make sure that your system is easily accessible for installation and service. See [Rack Specifications and Recommendations](#) on page 45 for more information.
- Use appropriate AC or DC power, power distribution, and grounding for your specific installation.
- Use a vinyl floor covering in your wiring closet. (Concrete floors accumulate dust, and carpets can cause static electricity.)

- Prevent unauthorized access to wiring closets by providing door locks. Install the equipment in a secured, enclosed, and restricted access location, ensuring that only qualified service personnel have access to the equipment.
- Provide adequate overhead lighting for easy maintenance.
- Be sure that each wiring closet has a suitable ground. All equipment racks and equipment installed in the closet should be grounded.
- Be sure that all system environmental requirements are met, such as ambient temperature and humidity.

**Note**

Consult an electrical contractor for commercial building and wiring specifications.

Control the Temperature

Extreme Networks equipment generates a significant amount of heat. It is essential that you provide a temperature-controlled environment for both performance and safety.

Install the equipment only in a temperature- and humidity-controlled indoor area that is free of airborne materials that can conduct electricity. Too much humidity can cause a fire. Too little humidity can produce electrical shock and fire.

Observe these additional thermal recommendations for the location where you plan to install your equipment:

- Ensure that the ventilation in the wiring closet is adequate to maintain a temperature below 50°C (122°F).
- Install a reliable air conditioning and ventilation system.
- Keep the ventilation in the wiring closet running during non-business hours; otherwise, the equipment can overheat.
- Maintain a storage temperature between -40°C (-40°F) and 70°C (158°F).

[Table 16](#) summarizes the behavior of ExtremeSwitching switches when they experience high operating temperatures.

Safeguards are built into all Extreme Networks switches and power supply units to minimize the risk of fire.

Table 16: Thermal Shutdown and Restart Behavior

Switch Model(s)	Behavior
All models	<p>When internal system temperatures exceed the thermal shutdown temperature limit (typically about 20°C higher than normal system operating temperatures), the system's power supplies are turned off and the switch shuts down. The system remains in the OFF state until the system has sufficient time to cool and the internal thermal sensor measures a temperature lower than the maximum specified ambient temperature, at which time the system restarts automatically.</p> <p>Alternately, you can restart the system by removing and then restoring all line power to the system. The internal sensor must still measure a system temperature that is lower than the maximum specified ambient temperature, so recovery might not be immediate.</p>

Control the Humidity Level

To maximize equipment life, keep operating humidity between 50% and 70% relative humidity (non-condensing) during typical operation.

The equipment can operate between 5% and 95% relative humidity (non-condensing) for short intervals.

Protect Your System from ESD (Electrostatic Discharge)

Your system must be protected from static electricity or ESD. Take the following measures to ensure optimum system performance:

- Remove materials that can cause electrostatic generation (such as synthetic resins) from the wiring closet.
Check the appropriateness of floor mats and flooring.
- Connect metal chassis, conduit, and other metals to ground using dedicated grounding lines.
- Use electrostatically safe equipment.
If you are working with pluggable interface modules, wear an ESD-preventive wrist strap and connect the metal end to a grounded equipment rack or other source of ground.

Rack Specifications and Recommendations

Racks should conform to conventional standards.

In the United States, use EIA Standard RS-310C: Racks, Panels, and Associated Equipment. In countries other than the United States, use IEC Standard 297. In addition, verify that your rack meets the basic mechanical, space, and earthquake requirements that are described in this section.

Mechanical Recommendations for the Rack

Use equipment racks that meet the following mechanical recommendations:

- Use an open style, 19-inch rack to facilitate easy maintenance and to provide proper ventilation.
- Use a rack made of steel or aluminum.
- The rack should use the universal mounting rail hole pattern that is identified in IEC Standard 297.
- The rack should have designated earth grounding connections (typically on the base).
- The rack must meet earthquake safety requirements equal to that of the installed chassis.
- The mounting holes should be flush with the rails to accommodate the chassis.
- The rack should support approximately 270 kg (600 lb).

Ground the Rack

The rack must be properly grounded.

Use a rack grounding kit and a ground conductor that is carried back to earth or to another suitable building ground.

At a minimum, follow these guidelines to ground equipment racks to the earth ground:

- CAD weld appropriate wire terminals to building I-beams or earth ground rods.
- For a DC-powered switch, use a minimum 14 AWG stranded copper wire for grounding.

AC-powered switches do not need separate chassis grounding.

- Position the earth ground as close to the equipment rack as possible to maintain the shortest wiring distance possible.
- Use a ground impedance tester or micro-ohm meter to test the quality of earth ground connection at the chassis. This will ensure good grounding between the chassis, rack, and earth ground.



Note

Because building codes vary worldwide, consult an electrical contractor to ensure proper equipment grounding for your specific installation.

Provide Adequate Space for the Rack

Provide enough space in front of and behind the switch so that you can service it easily.

Allow a minimum of 48 inches (122 cm) in front of the rack and 30 inches (76 cm) behind the rack. When using a relay (two-post) rack, provide a minimum of 24 inches (61 cm) of space behind the mounted equipment. Extra room on each side is optional.

**Warning**

Extreme Networks switches do not have a switch for turning power to the unit on and off. For systems using an AC power supply, power to the switch is disconnected by removing the wall plug from the electrical outlet.

Be sure that cables and other equipment do not block the switch's air intake or outflow.

Depending on other conditions in the equipment room, it may be possible to install the switches closer to each other; consult your Extreme Networks Customer Support representative for guidance.

Secure the Rack

The rack should be attached to the wiring closet floor with 9.5 mm (3/8 in) lag screws or equivalent hardware. The floor under the rack should be level within 5 mm (3/16 in). Use a floor-leveling cement compound if necessary or bolt the racks to the floor as shown.

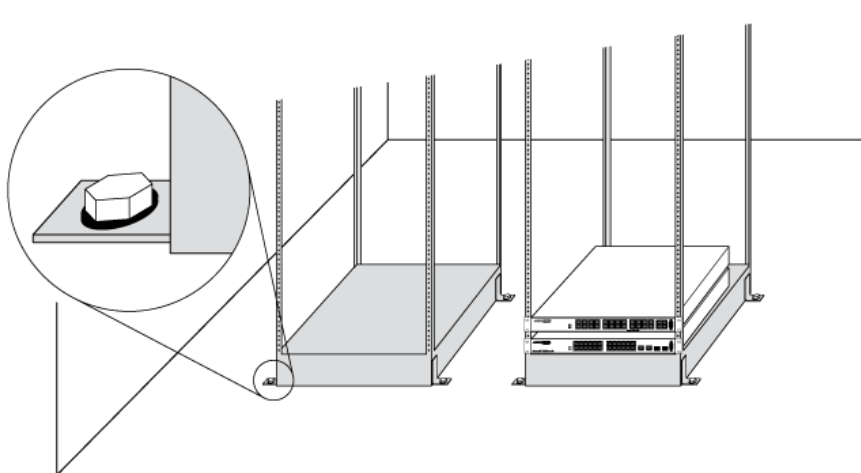

Figure 31: Properly Secured Rack

Brace open equipment racks if the channel thickness is less than 6.4 mm (1/4 in).

Evaluate and Meet Cable Requirements

Use professional consultants for site planning and cabling.

The Building Industry Consulting Service International (BICSI) Registered Communications Distribution Designer (RCDD), which is globally recognized as a standard in site planning and cabling, can be used.

For information, visit www.bicsi.org.

Label Cables and Keep Accurate Records

A reliable cable labeling system is essential when planning and installing a network.

Keeping accurate records helps you to:

- Relocate devices easily.
- Make changes quickly.
- Isolate faults in the distribution system.
- Locate the opposite end of any cable.
- Know the types of network devices that your cabling infrastructure can support.

Follow these guidelines when setting up a cable labeling system suitable for your installation:

- Identify cables by securely attaching labels to all cable ends.
- Assign a unique block of sequential numbers to the group of cables that run between each pair of wiring closets.
- Assign a unique identification number to each equipment rack.
- Identify all wiring closets by labeling the front panel of your Extreme Networks equipment and other hardware.
- Keep accurate and current cable identification records.
- Post records near each equipment rack. For each cable drop, include information about the cable source, destination, and jumper location.

Install Cable

When you connect cable to your network equipment, keep the following things in mind.

- Examine cable for cuts, bends, and nicks.
- Support cable using a cable manager that is mounted above connectors to avoid unnecessary weight on the cable bundles.
- Use cable managers to route cable bundles to the left and right of the network equipment to maximize accessibility to the connectors.
- Provide enough slack, approximately 5 to 7.5 cm (2 to 3 in), to provide proper strain relief as shown in [Figure 32](#) on page 49.
- Bundle cable using hook-and-loop straps to avoid injuring cables.
- If you build your own cable, be sure that connectors are properly crimped.
- When installing a patch panel using twisted pair wiring, untwist no more than 2.5 cm (1 in) of the cable to avoid radio frequency (RF) interference.
- Discharge the RJ45 Ethernet cable before plugging it into a port on the switch.



Caution

Unshielded twisted pair (UTP) cable can build up electrostatic charges when being pulled into a new installation. Before connecting any category 5 UTP cable to the switch, discharge ESD from the cable by plugging the RJ45 connector into a LAN static discharge device or use an equivalent method.

- Use plenum-rated cable when it is necessary for safety and fire rating requirements. Consult your local building codes to determine when it is appropriate to use plenum-rated cable, or refer to IEC standard 850.
- Keep all ports and connectors free of dust.

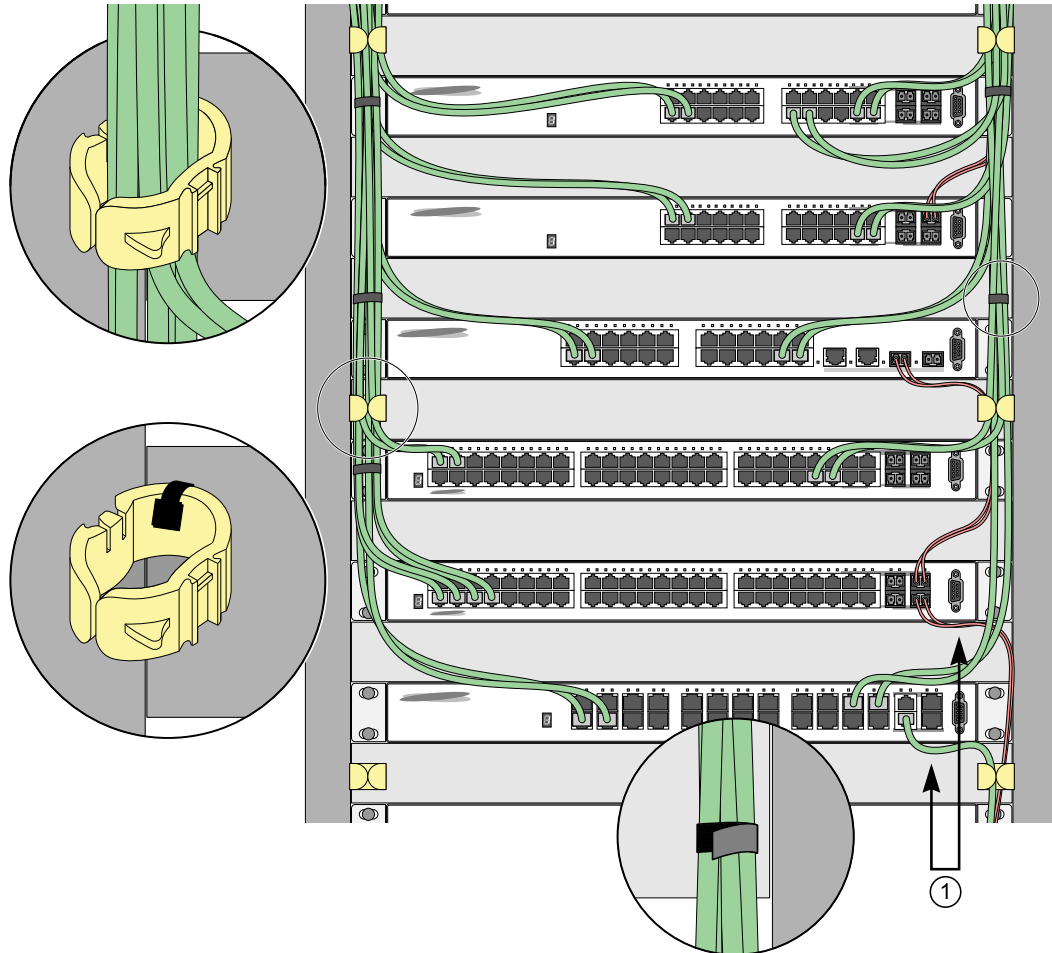

Figure 32: Properly Installed and Bundled Cable

1 = Ensure adequate slack and bend radius

Handle Fiber Optic Cable

Fiber optic cable must be handled carefully during installation.

Every cable has a minimum bend radius, example, and fibers will be damaged if the cables are bent too sharply. It is also important not to stretch the cable during

installation. Ensure that the bend radius for fiber optic cables is equal to at least 5 cm (2 in) for each 90-degree turn as shown in [Figure 33](#).



Note

Kinks and sharp bends can destroy or impair the cable's ability to convey light pulses accurately from one end of the cable to the other. Use care in dressing the optical fiber cables: provide satisfactory strain relief to support the cable and maintain an adequate bend radius at all cable turns, particularly where the cable connects to the I/O module.

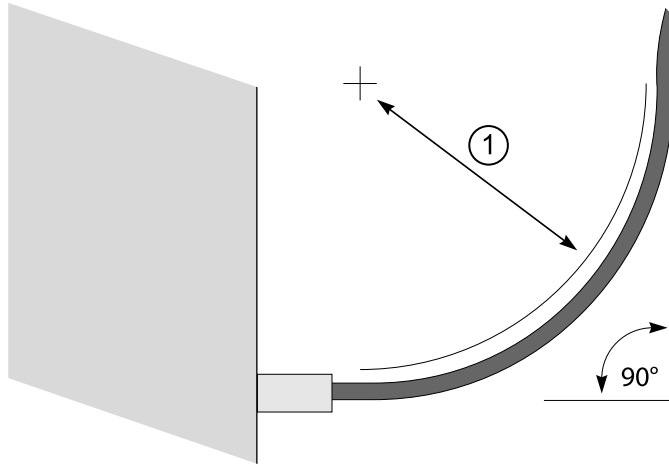

Figure 33: Bend Radius for Fiber Optic Cable

1 = Minimum 5 cm (2 in) radius in 90° bend

Cable Distances and Types

[Table 17](#) shows one example of cable media types and maximum distances that support reliable transmission in accordance with international standards (except where noted). Refer to the [Extreme Optics](#) website for descriptions of optics and cables, as well as a complete list of supported cable lengths, and a list of the cable types that are compatible with your equipment.

Table 17: Cable Distances and Types

Standard	Media Type	MHz·km Rating	Maximum Distance (Meters)
1000BASE-SX (850nm optical window)	50/125 μm multimode fiber	400	500
	50/125 μm multimode fiber	500	550
	62.5/125 μm multimode fiber	160	220
	62.5/125 μm multimode fiber	200	275

Table 17: Cable Distances and Types (continued)

Standard	Media Type	MHz·km Rating	Maximum Distance (Meters)
1000BASE-LX (1300nm optical window)	50/125 µm multimode fiber	400	550
	50/125 µm multimode fiber	500	550
	62.5/125 µm multimode fiber	500	550
	10/125 µm single-mode fiber	–	5,000
	10/125 µm single-mode fiber	–	10,000
1000BASE-ZX (1550nm optical window)	10/125 µm single-mode fiber	–	80,000
100BASE-LX100 (1550nm optical window)	10/125 µm single-mode fiber	–	100,000
1000BASE-BX10 (1490nm optical window) (1310nm optical window)	10/125 µm single-mode fiber	–	10,000
1000BASE-LX70 (1550nm optical window)	10/125 µm single-mode fiber	–	70,000
10/100/1000BASE-T SFP	(1 Gbps link) Category 5 and higher UTP cable	–	100
	(100 Mbps link) Category 5 and higher UTP cable	–	150
	(10 Mbps link) Category 5 and higher UTP cable	–	250
10GBASE-T SFP+	(10 Gb links) Category 6A and higher UTP cable	–	30
10GBASE-SR SFP+ (850nm optical window)	62.5 µm multimode fiber	160	26
	62.5 µm multimode fiber (OM1)	200	33
	50 µm multimode fiber	400	66
	50 µm multimode fiber (OM2)	500	82
	50 µm multimode fiber (OM3)	2000	300
10GBASE-LR SFP+ (1310nm optical window)	10/125 µm single-mode fiber	–	10,000
10GBASE-ER SFP+ (1550nm optical window)	10/125 µm single-mode fiber	–	40,000

¹ Proprietary to Extreme Networks. Connections between two Extreme Networks 1000BASE-LX interfaces that use 10/125 µm single-mode fiber can use a maximum distance of 10,000 meters.

Table 17: Cable Distances and Types (continued)

Standard	Media Type	MHz·km Rating	Maximum Distance (Meters)
40GBASE-SR4 QSFP+ (850nm optical window)	50 μm multimode fiber (OM3)	–	100
	50 μm multimode fiber (OM4)	–	150
1000BASE-T	Category 5 and higher UTP cable	–	100
100BASE-TX	Category 5 and higher UTP cable	–	100
10BASE-T	Category 3 and higher UTP cable	–	100

Table 18 and Table 19 on page 52 list direct-attach cables available from Extreme Networks.

Table 18: Extreme Networks 100Gb Direct-Attach Cables

Cable Type	Part Number	Length
QSFP28-QSFP28 Direct attach passive copper cable	10411 or AA1405029-E6	1 meter
	10413 or AA1405031-E6	3 meters
	10414 or AA1405032-E6	5 meters
QSFP28-4xSFP28 (4x25Gb) Direct attach passive copper breakout	10421	1 meter
	10423	3 meters
	10424	5 meters
QSFP28-4xSFP28 (4x25Gb) Active optical breakout cable	10444	20 meters

Table 19: Extreme Networks 40Gb Direct-Attach Cables

Cable Type	Part Number	Length
QSFP+ to QSFP+ Direct attach cable	AA1404037-E6	0.5 meter
	AA1404029-E6	1 meter
	AA1404030-E6	2 meters
	AA1404031-E6	3 meters
	AA1404032-E6	5 meters
QSFP+ to QSFP+ Active optical cable	AA1404028-E6	10 meters active optical

Table 19: Extreme Networks 40Gb Direct-Attach Cables (continued)

Cable Type	Part Number	Length
QSFP+ to 4xSFP+ Breakout cable	AA1404033-E6	1 meter
	AA1404035-E6	3 meters
	AA1404036-E6	5 meters
	AA1404041-E6	10 meters active optical

Use RJ45 Connector Jackets

Use RJ45 cable with connector jackets that are flush with the connector or that have connectors with a no-snag feature.

Using cable with jackets that are wider than the connectors can cause:

- Connectors that are not properly aligned with the port.
- Crowded cable installation, which can cause connectors to pop out of the port.

Figure 34 shows examples of recommended and non-recommended connector jacket types.

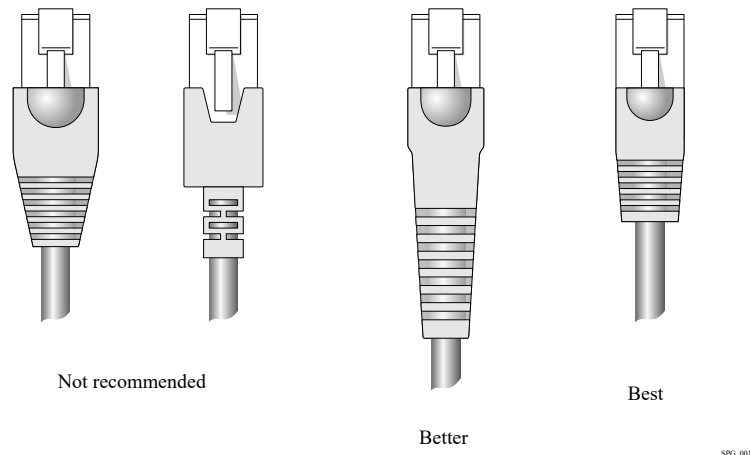

Figure 34: RJ45 Connector Jacket Types

Prevent Radio Frequency Interference (RFI)

If you use UTP cabling in an installation, take precautions to avoid radio frequency (RF) interference.

RF interference can cause degradation of signal quality, and, in an Ethernet network environment, can cause excessive collisions, loss of link status, or other physical layer problems that can lead to poor performance or loss of communication.

To prevent RF interference, avoid the following situations:

- Attaching UTP cable to AC power cables
- Routing UTP cable near antennas, such as a ham radio antenna
- Routing UTP cable near equipment that could exhibit RF interference, such as ARC welding equipment
- Routing UTP cable near electrical motors that contain coils
- Routing UTP cable near air conditioner units
- Routing UTP cable near electrical transformers

In areas or applications where these situations cannot be avoided, use fiber optic cabling or shielded twisted pair cabling.

Meet Power Requirements

Observe the following requirements and precautions for powering your hardware.

Requirements for PoE Devices

When connecting PoE devices to a PoE switch, all connections between the PoE device and the switch must remain within the same building and use a low-voltage power distribution system per IEEE 802.3af.

Power Supply Requirements

Follow these recommendations when you plan power supply connections for your equipment:

- Place the equipment in an area that accommodates the power consumption and component heat dissipation specifications.
- Be sure that your power supply meets the site DC power or AC power requirements of the network equipment.
- When you connect power to installed equipment, do not make this connection through an extension cord or power strip.
- If your switch includes more than one power supply, connect each power supply to a different, independent power source.

If a power source fails, it will affect only the switch power supply to which it is connected. If all switch power supplies are connected to a single power source, the entire switch is vulnerable to a power source failure.

- In regions that are susceptible to electrical storms, plug your system into a surge suppressor.

For detailed power specifications for your equipment, see "Technical Specifications."

Requirements for Power Cords

Most ExtremeSwitching switches do not ship with power cords. Visit www.extremenetworks.com/product/powercords/ for information on selecting and

purchasing the correct power cords for use with specific Extreme Networks equipment. The web page provides specifications for power cords in each country so that you can purchase cords locally.

AC power cords must meet the requirements listed in [Power Cord Requirements for AC-Powered Switches and AC Power Supplies](#) on page 148.

UPS (Uninterruptible Power Supply) Requirements

A UPS (uninterruptible power supply) is a device that sits between a power supply (such as a wall outlet) and a device (such as a switch) to prevent outages, sags, surges, and bad harmonics from adversely affecting the performance of the device.

A UPS traditionally can perform the following functions:

- Absorb relatively small power surges.
- Smooth out noisy power sources.
- Continue to provide power to equipment during line sags.
- Provide power for a period of time after a blackout has occurred.

In addition, some UPS devices or UPS-plus-software combinations provide the following functions:

- Automatically shut down equipment during long power outages.
- Monitor and log power supply status.
- Display the voltage (current draw) of the equipment.
- Restart equipment after a long power outage.
- Display the voltage currently on the line.
- Provide alarms on certain error conditions.
- Provide short-circuit protection.

Select a UPS

To determine UPS requirements for your switch, answer these questions:

- What are the amperage requirements?
- What is the longest potential time period that the UPS would be required to supply backup power?
- Where will the UPS be installed?
- What is the maximum transition time that the installation will allow? (See [Provide a Suitable UPS Transition Time](#) on page 56.)



Note

Use a UPS that provides online protection.

Calculate Volt-Amperage Requirements

To determine the size of UPS that you need:

1. Locate the voltage and amperage requirements for each piece of equipment.
These numbers are usually found on a sticker on the back or bottom of your equipment.
2. Multiply the numbers together to get Volt-Amperes (VA):
 $VA = \text{Volts} \times \text{Amperes}$
3. Add the VA from all the pieces of equipment together to find the total VA requirement.

To determine the minimum volt-amperage requirements for your UPS, add 30% to the total.

Provide a Suitable UPS Transition Time

UPS transition time is the time required for the UPS to change from providing AC power derived from the utility (or mains) supply to providing AC power derived from the battery backup. UPS transition time is sometimes called *UPS transfer time*.

UPS transition times vary between UPS models and implementations, but shorter transition times are preferred. For Extreme Networks stacking products, a UPS transition time of 20 milliseconds or less ensures optimum performance and minimizes service interruptions.

For high-availability and fault-tolerant installations in which the switches use redundant power supply units (PSUs), ensure that each PSU in a switch is connected to a different UPS and that each UPS is powered by an independent AC supply. This will prevent service interruptions when a power source is lost, or when a UPS unit fails. (Note that a single, appropriately sized UPS can power PSUs in multiple switches. The recommendation is simply that for any given switch, the two PSUs should be connected to different UPS units.)

DC Power Requirements

This system should be installed in a DC-I battery return configuration.

In a DC-I configuration, the battery return conductor should be connected directly to the central office power return bus, and not to the equipment frame or the grounding means of the equipment.

Follow Applicable Industry Standards

Always follow applicable industry standards.

For more information, see the following ANSI/TIA/EIA standards:

- ANSI/TIA/EIA-568-A—the six subsystems of a structured cabling system
- ANSI/TIA/EIA-569-A—design considerations
- ANSI/TIA/EIA-606—cabling system administration
- ANSI/TIA/EIA-607—commercial building grounding and bonding requirements

You can access these standards at: www.ansi.org or www.tiaonline.org.



Build Stacks

[Introduction to Stacking](#) on page 58

[Plan to Create Your Stack](#) on page 68

[Set up the Physical Stack](#) on page 72

A stack consists of a group of up to eight switches that are connected to form a ring. The stack offers the combined port capacity of the individual switches; it operates as if it were a single switch, making network administration easier.

Stacking is facilitated by the SummitStack feature – part of the Switch Engine and ExtremeXOS Edge license.

This topic describes the supported configurations for stacking switches, the considerations for planning a stack, and the steps for setting up the hardware. Read this chapter before installing the switches that will make up the stack.

Refer to the Stacking chapter in the [Switch Engine 32.1 User Guide](#) for information about configuring a stack, maintaining the stack configuration, and troubleshooting.

Introduction to Stacking

When stacking switches, the stack operates as if it were a single switch with a single IP address and a single point of authentication. One switch – called the primary switch – is responsible for running network protocols and managing the stack. The primary runs Switch Engine software and maintains all the software tables for all the switches in the stack.

All switches in the stack, including the primary switch, are called nodes. [Figure 35](#) shows four nodes in a stack, connected to each other by SummitStack cables.

All connections between stack ports must be directly between switches. A stacking connection cannot pass through a third device, for example a Virtual Port Extender or an LRM/MACsec Adapter.

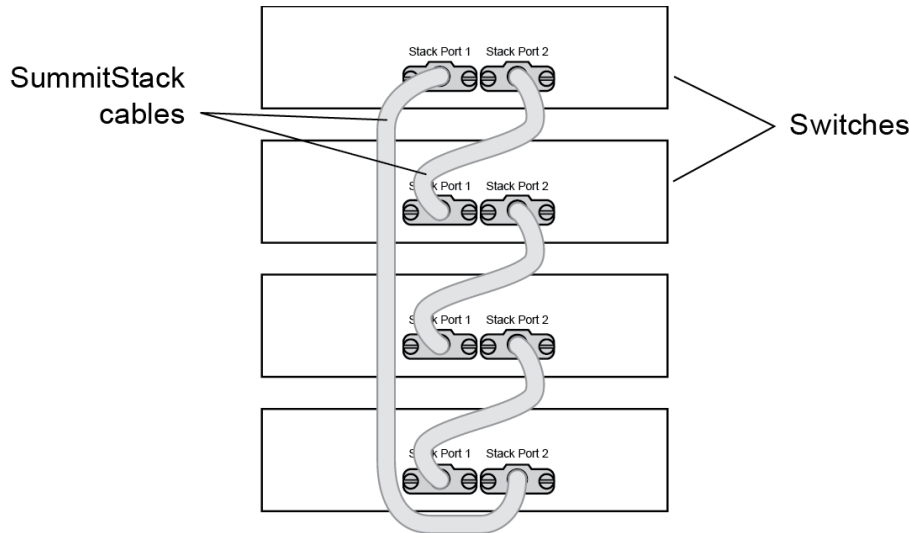

Figure 35: Switches Connected to Form a Stack

Using the SummitStack feature—part of the Switch Engine Edge license—a stack can combine switches from different series, provided that every switch in the stack:

- Runs in the same partition (primary or secondary).
- Runs the same version of Switch Engine.
- Includes support for stacking.

See [Combine Switches from Different Series](#) on page 70 for information about which switch series can be combined to form a stack.

The following topics introduce you to the basic principles of stacking and provide recommendations for creating stacks.

More information to answer your questions about stacking and help you plan your configuration is available on the [Extreme Networks GTAC Knowledge Base](#).

Build Basic Stacks

A stack can be created in either of two ways:

- In *native stacking*, switches are connected using either designated Ethernet data ports or dedicated stacking connectors.
- In *alternate stacking*, switches are connected using 10-Gbps Ethernet data ports that have been configured for stacking. These ports are located either on the switch itself or on option cards installed on either the front or the rear of the switch.

When planning and building your stack, be sure to follow port compatibility and cabling recommendations as described in this chapter.

Slot Numbers in Stacks

A switch stack can be thought of as a virtual chassis. Each switch (node) operates as if it were occupying a slot in a chassis and is controlled by the primary. The high-speed stacking links function like the backplane links of a chassis.

Each switch in the stack is assigned a “slot number” during the initial software configuration of the stack. Starting at the switch with the console connection, numbers are assigned in numerical order following the physical path of the connected stacking cables. For example, if you follow the cabling recommendations presented in [Connect the Switches to Form the Stack Ring](#) on page 72 and configure a vertical stack from the console on the switch at the top of the physical stack, the switches will be assigned slot numbers 1 through 8 from the top down.

The top half of the number blinks if the switch is the primary, and the bottom half blinks if it is the backup. If the LED is steadily lit, the switch is a standby. If the LED is off the switch is not configured as a member of a stack.

The Mode button is used to cycle through three display modes for the port LEDs. After two presses of the Mode button, the port LEDs will enter the STK Display Mode, indicated by the STK LED. STK mode is used to indicate slot presence and slot number via the first eight port LEDs.

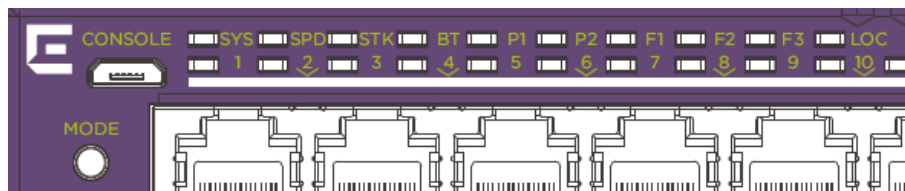

Figure 36: Mode Button with STK LED Example

The LED is steady green if the link is OK, blinking green if traffic is present, and off if no signal is present.

A quick way to verify that the cable connections match the software configuration is to check the stack number indicator on each switch. If the slot numbers do not line up in the order you arranged the switches, this might indicate that the stacking cable setup differs from what you intended when you configured the software. In this case, reconnect the cables in the correct order and perform the software configuration again.

Primary/Backup Switch Redundancy

When your stack is operational, one switch is the primary switch, responsible for running network protocols and managing the stack.

To provide recovery in case of a break in the stack connections, you can configure redundancy by designating a backup switch to take over as primary if the primary switch fails. When you perform the initial software configuration of the stack, the “easy setup” configuration option automatically configures redundancy, with slot 1 as the primary and slot 2 as the backup. You can also configure additional switches as “primary-capable,” meaning they can become a stack primary in case the initial backup switch fails.

When assigning the primary and backup roles in mixed stacks, consider the feature scalability and the speed of each switch model. The easy setup configuration process selects primary and backup switches based on capability and speed. The following list

shows the capabilities based on the ability to cross stack with other switch families. The most capable switches are shown at the top of each list:

1. ExtremeSwitching 5720
2. ExtremeSwitching 5520

For example, in a stack that combines 5720 series switches with 5520 series switches, a 5720 series switch might provide more memory and more features than the 5520 series switches in the stack. Consider these differences when selecting a primary node, selecting a backup node, and configuring failover operation.

**Important**

The 5720 series switches can be stacked with themselves using Native V400 stacking (SummitStack-V400) or with the 5520 series switches using Native V200 stacking (SummitStack-V200). Assign the primary and backup roles to switches from the same series. For example, if the primary node is a 5720 series switch, the backup node must also be a 5720 series switch. The 5520 series switches must only be used as standby nodes when they are in a mixed stack with 5720 Series switches. Similarly, if the primary node is an 5520 series switch, the backup node must also be an 5520 series switch.

When easy setup compares two switches that have the same capability, the lower slot number takes precedence.

Follow the same ranking hierarchy when you plan the physical placement of the switches in the stack.

SummitStack Topologies

[Figure 37](#) presents a graphical representation of a stack and some of the terms that describe stack conditions.

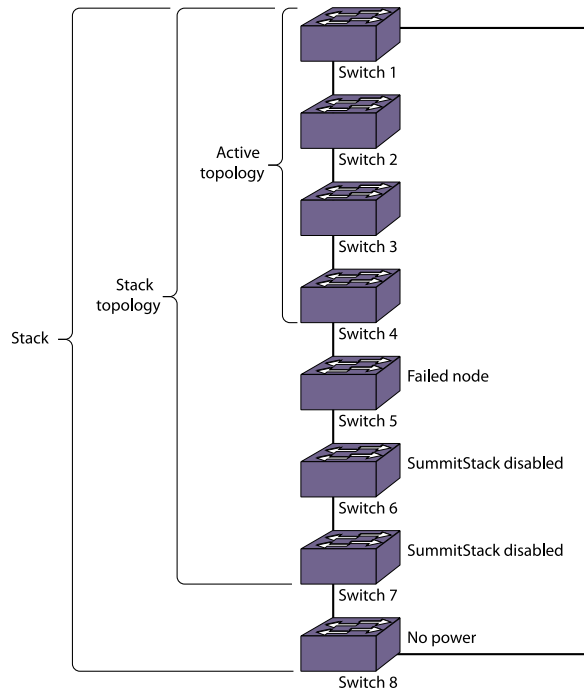

Figure 37: Example of a Stack, Showing the Active Topology and the Stack Topology

A stack is the collection of all switches, or nodes, that are cabled together to form one virtual switch using the Switch Engine SummitStack feature.

The maximum cable length supported between switches depends on the types of switches in your stack, the installed option cards, and the configured stacking ports. For more information, see [Plan to Create Your Stack](#) on page 68.

A stack topology is the set of contiguous nodes that are powered up and communicating with each other. In the example shown, Switch 8 is not part of the stack topology because it is not powered up.

An active topology is the set of contiguous nodes that are active. An active node is powered up, is configured for stack operation, and is communicating with the other active nodes.

Switch 5 in the example has failed, stacking is disabled on Switches 6 and 7, and Switch 8 has no power. As a result, the active topology includes Switches 1 through 4 only.

For more information about SummitStack terminology, see [SummitStack Terms](#) on page 64.

Ring Topology: Recommended for Stacking

SummitStack nodes should be connected to each other in a ring topology. In a ring topology, one link is used to connect to a node and the other link is used to connect to another node. The result forms a physical ring connection. This topology is highly recommended for normal operation.

[Figure 38](#) represents a maximal ring topology of eight active nodes.

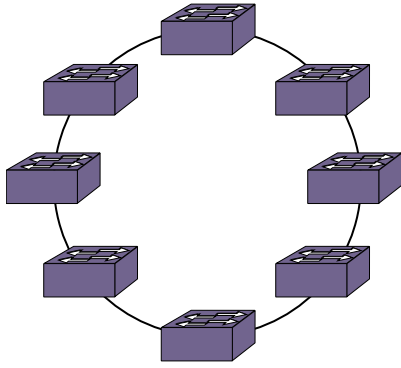

Figure 38: Graphical Representation of a Ring Topology

Figure 39 shows what the same ring topology would look in actual practice. Each switch in the rack is connected to the switch above it and the switch below it. To complete the ring, a longer cable connects Switch 1 with Switch 8.

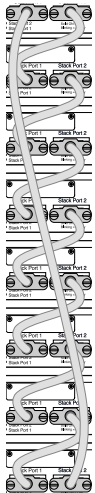

Figure 39: Switches Connected to Each Other in a Ring Topology

Note that, while a physical ring connection may be present, a ring active topology exists only when all nodes in the stack are active.

Daisy Chain Topology: Not Recommended for Stacking

Stackable switches can be connected in a daisy-chain topology. This is a [ring topology](#) with one of the links disconnected, inoperative, or disabled. A daisy chain can be created when a link fails or a node reboots in a ring topology, but the daisy chain topology is not recommended for normal operation.

Connect your stack nodes in a ring topology, not a daisy-chain topology, for normal operation.

In [Figure 40](#), the nodes delineated as the active topology are operating in a daisy-chain configuration, even though there is physically a ring connection in the stack.



Figure 40: Daisy Chain Topology

You might need to use a daisy chain topology while adding a new node, removing a node, or joining two stacks.

If you are using a daisy chain topology, the possibility of a dual primary condition increases. Before you create a daisy chain topology, read "Managing a Dual Primary Situation" in the [Switch Engine 32.1 User Guide](#).

SummitStack Terms

[Table 20](#) describes the terms used for the SummitStack feature. These terms are listed in the recommended reading sequence.

Table 20: List of Stacking Terms

Term	Description
Stackable switch	An ExtremeSwitching switch that provides two stacking ports and can participate in a stack.
Stacking port	A physical interface of a stackable switch that is used to allow the connection of a stacking link. Stacking ports are point-to-point links that are dedicated for the purpose of forming a stack.
Native stacking	A stacking configuration in which stack members are connected using either designated Ethernet data ports or dedicated stacking connectors.

Table 20: List of Stacking Terms (continued)

Term	Description
Alternate stacking	A stacking configuration in which stack members are connected using 10-Gbps Ethernet data ports that have been configured for stacking. These ports are located either on the switch itself or on option cards installed on the rear of the switch.
Stacking link	A cable that connects a stacking port of one stackable switch to a stacking port of another stackable switch, plus the stacking ports themselves.
Node	A switch that runs the Switch Engine operating system and is part of a stack. Synonymous with <i>stackable switch</i> .
Stack	A set of stackable switches and their connected stacking links made with the intentions that: (1) all switches are reachable through their common connections; (2) a single stackable switch can manage the entire stack; and (3) configurable entities such as VLANs and link trunk groups can have members on multiple stackable switches. A stack consists of all connected nodes regardless of the state of the nodes.
Stack topology	A contiguously connected set of nodes in a stack that are currently communicating with one another. All nodes that appear in the <code>show stacking</code> command display are present in the stack topology.
Stack path	A data path that is formed over the stacking links for the purpose of determining the set of nodes that are present in the stack topology and their locations in the stack. Every node is always present in a stack path whether or not stacking is enabled on the node.
Control path	A data path that is formed over the stacking links that is dedicated to carrying control traffic, such as commands to program hardware or software image data for software upgrade. A node must join the control path to fully operate in the stack. A node that is disabled for stacking does not join the control path, but does communicate over the stack path.
Active node	A node that has joined the control path. The active node can forward the control path messages or can process them. It can also forward data traffic. Only an active node can appear as a card inserted into a slot when the <code>show slot {slot} {detail} detail</code> command is executed on the primary node of the stack.
Active topology	A contiguous set of active nodes in a stack topology plus the set of stacking links that connect them. When an active topology consists of more than one node, each node in the active topology is directly and physically connected to at least one other node in the active topology. Thus, the active topology is a set of physically contiguous active nodes within a stack topology.

Table 20: List of Stacking Terms (continued)

Term	Description
Candidate node	A node that is a potential member of an active topology, or an active node that is already a member of an active topology. A candidate node may or may not be an active node – that is, it may or may not have joined the control path.
Node role	The role that each active node plays in the stack – either primary, backup, or standby.
Primary node	<p>The node that is elected as the primary node in the stack. The primary node runs all of the configured control protocols such as OSPF (Open Shortest Path First), RIP (Routing Information Protocol), Spanning Tree, and EAPS (Extreme Automatic Protection Switching).</p> <p>The primary node controls all of its own data ports as well as all data ports on the backup and standby nodes. To accomplish this, the primary node issues specific programming commands over the control path to the backup and standby nodes.</p>
Backup node	<p>The node assigned to take over the role of primary if the primary node fails. The primary node keeps the backup node's databases synchronized with its own databases in preparation for such an event.</p> <p>If and when the primary node fails, the backup node becomes the primary node and begins operating with the databases it has previously received. In this way, all other nodes in the stack can continue operating.</p>
Standby node	A node that is prepared to become a backup node in the event that the backup node becomes the primary node. When a backup node becomes a primary node, the new primary node synchronizes all of its databases to the new backup node. When a node operates in a standby role, most databases are not synchronized – except those few that directly relate to hardware programming.
Acquired node	<p>A standby or backup node that is acquired by a primary node. This means that the primary node has used its databases to program the hardware of the standby or backup node. The standby or backup node has acted as a hardware programming proxy, accepting the instructions of the primary node to do so.</p> <p>An acquired backup node maintains the databases needed to reflect why the hardware is programmed as it is. However, a standby node does not. An acquired node can be re-acquired (without a reboot) by the backup node only when the backup node becomes the primary node, and only when both the backup and standby nodes were already acquired by the same primary node at the time of its failure.</p>
Data ports	The set of ports on a stackable switch that are available for connection to your data networks. Such ports can be members of a user-configured VLAN or trunk group. They can be used for Layer 2 and 3 forwarding of user data traffic, for mirroring, or other features you can configure. Data ports are different from stacking ports.

Table 20: List of Stacking Terms (continued)

Term	Description
Failover	The process of changing the backup node to the primary node when the original primary node has failed. When a primary node fails, if a backup node is present, and if that node has completed its initial synchronization with the primary node, then the backup node assumes the role of primary node. The standby nodes continue their operation and their data ports do not fail.
Hitless failover	A failover in which all data ports in the stack, except those of the failing primary node, continue normal operation when the primary node fails.
Node address	The unique MAC address that is factory-assigned to each node.
Node role election	The process that determines the role for each node. The election takes place during initial stack startup and elects one primary node and one backup node. An election also takes place after a primary node failover, when a new backup node is elected from the remaining standby nodes.
Node role election priority	A priority assigned to each node, to be used in node role election. The node with the highest node role election priority during a role election becomes the primary node. The node with the second highest node role election priority becomes the backup.
Operational node	A node that has achieved operational state as a card in a slot. The operational state can be displayed using the <code>show slot {slot} {detail} detail</code> command.
System uptime	The amount of time that has passed since the last node role election. You can display the system uptime by entering the <code>show switch {detail}</code> command on the primary node.
Stack segment	A collection of nodes that form a stack topology. The term is useful when a stack is severed. Each severed portion of the stack is referred to as a stack segment.
Stack state	A state assigned by the stack to a node. You can display the stack state by entering the <code>show stacking</code> command.
Easy Setup	A procedure that automatically configures the essential stacking parameters on every node for initial stack deployment, and then automatically reboots the stack to put the parameters into effect. The choice to run Easy Setup is offered when you run the <code>enable stacking {node-address node-address}</code> command and the essential stacking parameters are unconfigured or inconsistent. It can also be invoked directly by running the <code>configure stacking easy-setup</code> command.

Plan to Create Your Stack

Use the information in the following topics to plan the physical makeup of your stack – switches, versatile interface modules (VIMs), and cables – and the stacking protocols you will use. Included are:

- Guidelines and other information for each switch model in your stack
- Considerations for combining different switch models in a stack
- Information about stacking cables

Enable and Disable the Stacking-Support Option

The stacking-support option is enabled by default for many switch and option card configurations. However, some configurations require you to enable the stacking-support option before a switch can participate in a stack.

- To enable stacking-support, issue the `enable stacking-support` command.
You must enable stacking-support individually for every switch in the stack that does not have stacking support enabled by default.
- To disable stacking support, configure the switch data ports to use the Ethernet protocol instead of the stacking protocol.

Use the `disable stacking-support` command.

Recommendations for Placing Switches for Stacked Operation

For best results in a SummitStack configuration, follow these recommendations for physically situating your equipment:

- Use the shortest possible stacking cables to connect the switches in the stack. This reduces the likelihood that the stacking cables might accidentally be damaged or disconnected. Stacking cables are available in lengths ranging from 0.3 meters to 100 meters.
- When possible, place all switches for the stack in the same rack or in adjacent racks. This facilitates using shorter stacking cables.
- The primary switch, or node, is the switch through which you will perform the initial stack configuration, using the console port. For simplicity and ease of connecting the stacking cables, plan to designate the top switch in a vertical physical stack as the primary switch. If switches are installed in several adjacent racks, place the primary switch at one end of the row.
- Physically locate the intended primary and backup nodes adjacent to each other, and plan to connect these nodes to each other directly so that Switch Engine application synchronization traffic is localized to a single stack link.
- On the primary node, connect the Ethernet management port to your management network.

- To provide management access to the stack in case of a failure in the primary switch, connect all switches that will participate in redundancy to your management network using the Ethernet management port on each switch.
- Use stacking cables to interconnect the stack nodes into a ring topology (see [Ring Topology: Recommended for Stacking](#) on page 62). Include only the nodes that you expect to be active in the stack.

Follow the recommendations in [Recommendations for Configuring Stacks](#) on page 69 to configure the software for your stack.

The recommended procedures for installing and interconnecting a stack are found in [Set up the Physical Stack](#) on page 72.

Recommendations for Configuring Stacks

When deploying a new stack, follow these recommendations for configuring the software:

- Plan to use the stack as if it were a single multi-slot switch. You need to decide the number and type of stackable switches in the stack and how the stack ports will be connected to the network.
- You can physically connect the stack to your networks before the nodes are configured. However, the default configuration on a switch in non-stacking mode assumes a default untagged VLAN that contains all switch ports. When first powered on, the switch acts as a Layer 2 switch, possibly resulting in network loops.
- Make sure all nodes support the SummitStack feature and are running the same Switch Engine software version. (See the [Switch Engine 32.1 Feature License Requirements](#).) To view the Switch Engine software version on a node, restart the node and run the command:

```
show version {detail | process name | images {partition partition}
{slot slot_number} } .
```

If any node does not have the right version, install the correct version on that node. Use the same image partition on all nodes. After stacking is enabled, images can be upgraded from the stack only if the same image is selected on all nodes.

- If you intend to deploy new units that might be part of a stack in the future, turn on stacking mode during initial deployment to avoid the need for a future restart. The only disadvantages of stacking mode are the loss of QoS (quality of service) profile QP7 and the reservation of some of the packet buffer space for stacking control traffic.
- You can configure the stack by logging into the primary node or any of the other nodes.
- If the primary-capable stackable switches have different purchased license levels, you might need to configure license level restrictions on some nodes before those nodes can join the stack. See the [Switch Engine 32.1 User Guide](#) for more information about managing licenses.

- If the stack supports any feature pack license (such as MPLS or Direct Attach), that feature pack license must be installed on all primary-capable nodes to support that feature and to prevent traffic interruption if a failover event occurs.
- Most stacking specific configurations are effective only after a restart. However, most non-stacking configuration commands take effect immediately and require no restart.
- A basic stack configuration can be achieved by using the Easy Setup procedure, as described in the [Switch Engine 32.1 User Guide](#).
- If EAPS, Spanning Tree, or any Layer 2 redundancy protocol is not running on the network, make sure that your network connections do not form a network loop.

Follow the recommendations in [Recommendations for Placing Switches for Stacked Operation](#) on page 68 for physically situating your equipment.

Combine Switches from Different Series

5520 Series switches can stack with themselves, or with 5320 Series or 5420 Series switches using Alternate stacking (10G link running at HG), or with 5720 series switches using Native V200 stacking (SummitStack-V200).

Select Stacking Cables

Stacking connections using the native stacking ports require stacking cables that are specific to the type of stacking port. These cables are available from Extreme Networks in lengths from 0.5 meter to 100 meters.



Note

For the most recent information about available cables, contact your Extreme Networks sales representative or refer to the [Extreme Optics](#) website.



Caution

Use of non-recommended cables or optics could cause stack instability.

Using the Extreme Stacking Tool

The Extreme Stacking Tool provides an easy way to plan your stack. As you select various switch models and stacking methods, the tool shows you:

- What switch models can be stacked together and which cannot.
- Statistics showing the routing options that are available with every stack combination.
- Recommendations about which switches should be the primary and backup nodes.
- Information about the supported versions of Switch Engine for every combination.

To use the Stacking Tool, follow these steps.

1. Open the Stacking Tool (<https://stackingtool.extremenetworks.com/StackingTool/>) in a web browser.



Note

The Stacking Tool is also available in the Support Tools section of the Extreme Portal.

2. Find a switch model in the **Switches** column.

Each switch model is represented by a rectangle, as shown in the example in the following figure. In this example, stacking ports are represented by U1 and U2 on the right side.

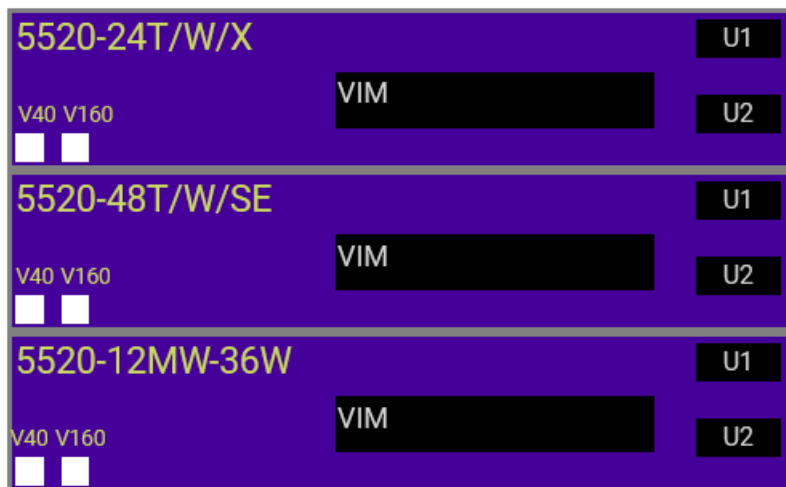

Figure 41: 5520 Switches Shown in the Stacking Tool



Tip

Select a rectangle to display more information about the switch model and the VIMs (if any) that it can use for stacking.

3. Drag the rectangle to the first slot in the Stack column in the middle of the page.

To the right of the Stack column, the tool displays statistics about available routes, supported software versions, and primary/backup recommendations.



Tip

If you don't see statistics and other information, select the arrow (> symbol) to the immediate right of the Stack column.

4. Use the tool in any of the following ways:
 - Select other switches and drag them to the slots in the stacking column.
 - For any switch in the stack, select the U1 and U2 symbols to choose stacking methods – for example, SummitStack-V and SummitStack-V80.
 - To remove a switch from the stack, drag it away from the stacking column.

Whenever you add or remove a switch from the stack, the statistics and recommendations update automatically.

In addition to statistics and recommendations, colors in the display show whether the selected switch models and stacking methods are compatible.

Table 21: Colors in the Stacking Tool Display

Color	Meaning
Green	Compatible and preferred
Blue	Compatible
Yellow	Incompatible with the selected primary node
Red	Incompatible

Set up the Physical Stack

After you have installed the individual switches (see "Installing Your Switch"), follow these steps to create the physical stack.

1. Connect the switches that will form the stack.
See [Connect the Switches to Form the Stack Ring](#) on page 72.
2. Connect the switches to your management network.
See [Connect Your Stack to the Management Network](#) on page 75.

After setting up and connecting the switches, perform software configuration for the stack. See "Configuring a New Stack" in the [Switch Engine 32.1 User Guide](#).

Connect the Switches to Form the Stack Ring

After you have installed the individual switches, connect them together using the stacking cables.

The examples in this section show cable connections and the recommended order for connecting ports to facilitate the easy setup configuration.

In general, it is best to connect Stack Port 2 on one switch to Stack Port 1 on the switch with the next higher slot number. Although you can connect the switches in any order, connecting them as shown in these examples will produce better predictability and easier software configuration.

All connections between stack ports must be directly between switches. A stacking connection cannot pass through a third device, for example a Virtual Port Extender or an LRM/MACsec Adapter.

It is essential to create an unbroken data path through all the switches in the stack.

Examples of Valid Stacking Configurations

The examples in the following sections show various physical stacking arrangements: all switches in a single rack, switches in two adjacent racks, and switches at the tops of several racks in a row.

Example: Basic Stack with Four Switches

This example shows a stack of four switches in a single rack.

The slot numbers presume a console connection to the switch at the top of the physical stack.

Figure 42 shows cable connections for a 4-node stack using SummitStack 40G cables to connect switches with integrated SummitStack ports.

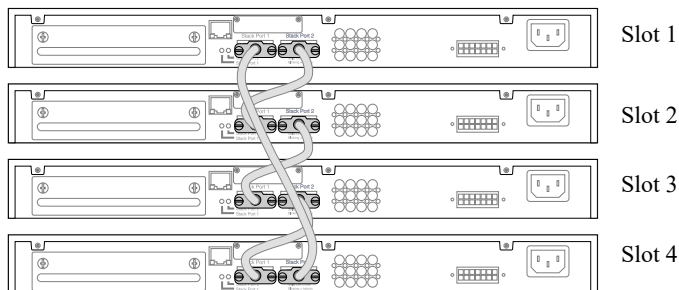

Figure 42: SummitStack Cable Connections Using Four Switches with Integrated SummitStack Ports

Table 22 lists the recommended order for connecting the stacking ports in this example.

Table 22: Basic Stack with Four Switches: Connections

Connect this slot and port To this slot and port	
Slot 1	Stack Port 2	Slot 2	Stack Port 1
Slot 2	Stack Port 2	Slot 3	Stack Port 1
Slot 3	Stack Port 2	Slot 4	Stack Port 1
Slot 4	Stack Port 2	Slot 1	Stack Port 1

Example: Basic Stack with Eight Switches

Figure 43 shows cable connections for an 8-node stack using SummitStack 40G cables to connect switches with integrated SummitStack ports.



Figure 43: SummitStack Cable Connections Using Eight Switches with Integrated SummitStack Ports

Table 23 lists the recommended order for connecting the stacking ports in this example.

Table 23: Basic Stack with Eight Switches: Connections

Connect this slot and port To this slot and port	
Slot 1	Stack Port 2	Slot 2	Stack Port 1
Slot 2	Stack Port 2	Slot 3	Stack Port 1
Slot 3	Stack Port 2	Slot 4	Stack Port 1
Slot 4	Stack Port 2	Slot 5	Stack Port 1
Slot 5	Stack Port 2	Slot 6	Stack Port 1
Slot 6	Stack Port 2	Slot 7	Stack Port 1
Slot 7	Stack Port 2	Slot 8	Stack Port 1
Slot 8	Stack Port 2	Slot 1	Stack Port 1

Example: Stacked Switches across Several Racks

Figure 44 shows five switches installed at the tops of five adjacent racks. To accommodate the shortest possible cables, immediately adjacent switches are not always connected together. Port 2 on one switch is connected to Port 1 on the next connected switch. If the easy setup feature is used to configure the stack parameters, the assigned slot numbers will be as shown in the figure.

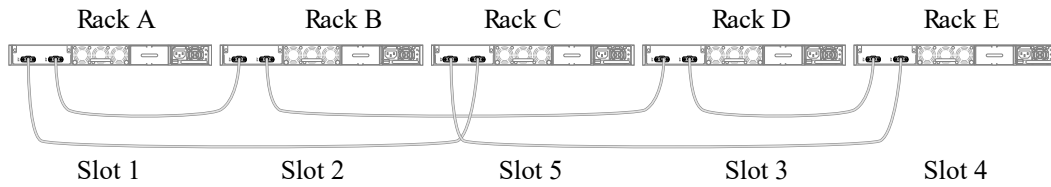

Figure 44: Top-of-Rack Stack Installation

Table 24 lists the recommended order for connecting the stacking ports in this example.

Table 24: Stacked Switches across Several Racks: Connections

Connect this slot and port To this slot and port		
Slot 1	Rack A	Port 2	Slot 2	Rack B	Port 1
Slot 2	Rack B	Port 2	Slot 3	Rack D	Port 1
Slot 3	Rack D	Port 2	Slot 4	Rack E	Port 1
Slot 4	Rack E	Port 2	Slot 5	Rack C	Port 1
Slot 5	Rack C	Port 2	Slot 1	(Rack A	Port 1

Connect Your Stack to the Management Network

Before you can configure Switch Engine for a new stack, your management console must be connected to at least one switch in the stack.

Connect your management console to the Ethernet management port on the switch that will become the stack primary node. If you plan to configure redundancy, connect to the console ports of all switches in the stack that will be primary-capable.

If you followed the cabling examples in [Connect the Switches to Form the Stack Ring](#) on page 72, and if you use the Easy Setup configuration procedure, only slots 1 and 2 can become the primary node. However, you can connect all switch management ports in the stack if you choose to do so. There is an alternate IP address configuration that will enable you to log in directly to each switch in the stack through its Ethernet management port.

See the [Switch Engine 32.1 User Guide](#) for instructions to perform the software configuration for your stack.



Install Your Switch

- [Safety Considerations for Installing Switches](#) on page 77
- [What You Will Need for the Installation](#) on page 77
- [Attach the Switch to a Rack or Cabinet](#) on page 78
- [Install Optional Components](#) on page 80
- [Install Internal AC Power Supplies](#) on page 80
- [Connect Network Interface Cables](#) on page 81
- [Turn on the Switch](#) on page 81

Before you attempt to install or remove an Extreme Networks switch, read the precautions in [Safety Considerations for Installing Switches](#) on page 77.

Extreme Networks switches fit into standard 19-inch equipment racks.

A four-post rack-mounting kit is provided with the switch. A two-post kit can be ordered separately.

The installation process includes the following tasks:

1. Prepare to install the switch.
See [What You Will Need for the Installation](#) on page 77.
2. Install the switch in the rack.
See [Attach the Switch to a Rack or Cabinet](#) on page 78.
3. Install optional components: optical transceivers and cables.
See the instructions in [Install Optional Components](#) on page 80.
4. Install one or two power supplies.
See [Install Internal AC Power Supplies](#) on page 80.



Note

Be aware of whether the power supply you are installing is AC-powered or a DC-powered. The installation instructions are different depending upon what type of power is used.

5. Power up the switch.
See [Turn on the Switch](#) on page 81.
6. Connect network interface cables.
See [Connect Network Interface Cables](#) on page 81.

7. Perform initial network connection and configuration.

See [Activate and Verify the Switch](#) on page 83.

Safety Considerations for Installing Switches

Read the information in this chapter thoroughly before you attempt to install or remove an Extreme Networks switch.

Ensure that proper ESD (electrostatic discharge) controls are in use before switch maintenance is performed. This includes but is not limited to wrist straps that are grounded to the switch housing and earth grounds.



Warning

Connect the chassis ground wire **before** you connect any DC power cables. Disconnect the ground wire **after** you disconnect all DC power cables.

Take care to load the equipment rack so that it is not top-heavy. Start installing equipment at the bottom of the rack and work up.

Do not cover vents that would restrict airflow.



Note

See [Safety and Regulatory Information](#) on page 152 for additional safety information.

See [Technical Specifications](#) on page 128 for additional information regarding regulatory compliance certifications.

What You Will Need for the Installation

Ensure that you have followed the guidance in "Preparing to Install," and ensure that you have the appropriate people and tools on hand.

Installing Extreme Networks switches is easiest when there are two people to maneuver the switch and attach mounting hardware.

Provide enough space in front of and behind the switch so that you can service it easily. Allow a minimum of 122 cm (48 in) in front of the rack and 76 cm (30 in) behind the rack.

If your switch has internal power supplies, make sure they have the same airflow direction as the fans in the switch.

Check *Quick Reference Guide* for your switch model to see what hardware is provided in the switch packaging. Most Extreme Networks switches come with the following hardware:

- Two rack mounting brackets (ears) adaptable for either a front-mount or mid-mount installation.
- Two long mounting brackets (rails) or slider kits for mounting in a four-post installation.

- Screws for attaching mounting hardware to the switch housing.

You need the following additional tools and equipment. These are not provided with your switch.

- Rack mounting screws: eight for a four-post installation; four for other installations. The size of the screws will vary based on the rack system you are using.
- Screwdriver for securing the rack mounting screws.
- #2 Phillips screwdriver to attach bracket screws that are provided with the switch. Use a magnetic screwdriver.
- AC power cord. For switches with removable AC power supplies, a separate power cord is needed for each installed power supply. The cord must meet the requirements listed in [Power Cord Requirements for AC-Powered Switches and AC Power Supplies](#) on page 148.
- ESD-preventive wrist strap for installing optional ports at the back of the switch.

Attach the Switch to a Rack or Cabinet

To attach a switch to a four-post rack or a cabinet, follow these steps.

Take care to load the rack so that it is not top-heavy. Start installing equipment at the bottom and work up.

1. On one side of the switch, set a mounting bracket against the switch housing. Set the flange even with the front panel of the switch – or, if you are mid-mounting the switch, set the flange toward the back of the switch.

The following figures illustrate how to attach the brackets for two common mounting options.

- [Figure 45](#) shows a mid-mount configuration using a short mounting bracket.
- [Figure 46](#) shows a front-mount configuration using a short mounting bracket.

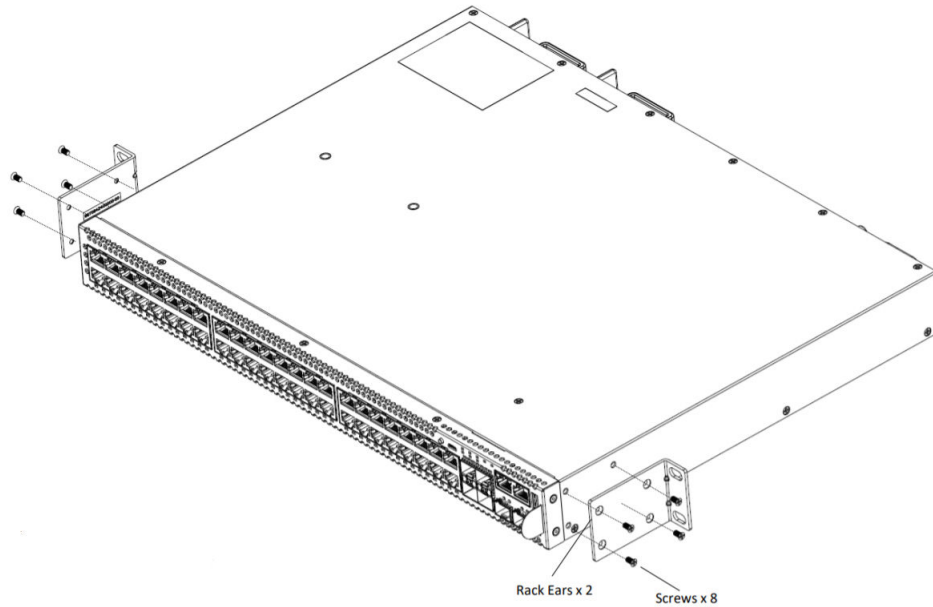

Figure 45: Mid-Mount: Attaching Short Mounting Brackets

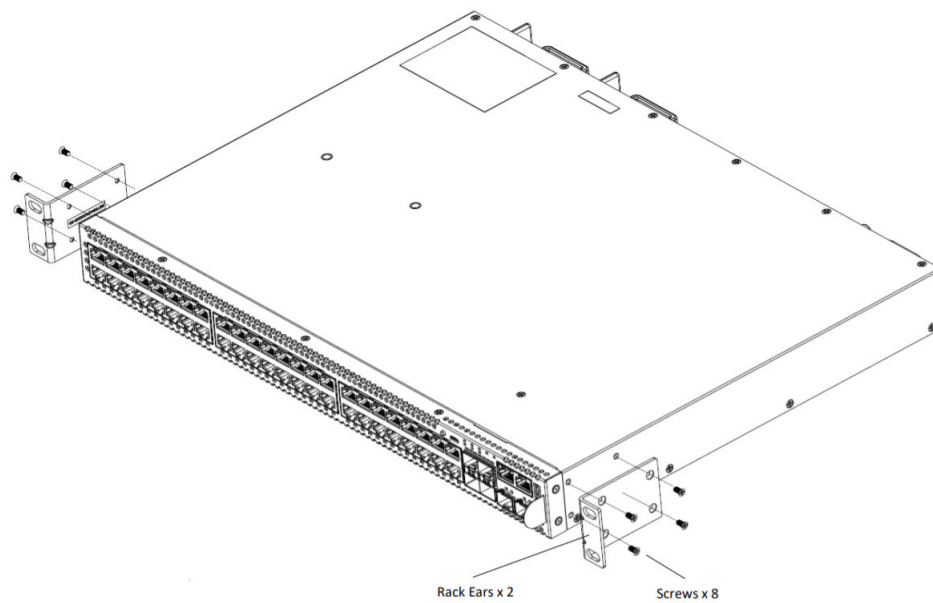

Figure 46: Front Mount: Attaching Short Mounting Brackets

2. Use the small bracket-mounting screws (provided) to secure the bracket to the switch housing.
If using screws other than those provided, ensure that the threaded length of the screws is within 4 to 5 cm.
3. Repeat step 1 and step 2 to attach the other bracket to the other side of the switch.
4. Secure the mounting bracket flanges to the rack, using screws that are appropriate for the rack.
(Rack-mounting screws are not provided.)

5. If a grounding lug is present, ground the switch.
 - a. At one end of the wire, strip the insulation to expose 1/2 inch (12 mm) of bare wire.
 - b. Identify the grounding lug on the back of the switch.
 - c. Insert the stripped wire into the grounding lug.
 - d. Tighten the retaining screw with a straight-tip torque screwdriver to 20 in-lb (2.25 N m).
 - e. Connect the other end of the wire to a known reliable earth ground point at your site.

After the switch is secured to the rack or cabinet, install optional components using the instructions in [Install Optional Components](#) on page 80.

After installing optional components, install one or two power supplies using the instructions in [Install Internal AC Power Supplies](#) on page 80.

Install Optional Components

After the switch is secured to the rack, install optional components.

ExtremeSwitching switches support the use of pluggable transceivers and cables in the SFP+, SFP28, QSFP+, and QSFP28 formats.

For a list of the optical components supported with ExtremeSwitching devices, see the [Extreme Optics](#) website.

Pluggable Transceiver Modules

Extreme Networks offers several optical transceiver modules for transmitting and receiving data over optical fiber rather than through electrical wires.

**Note**

A small flat-blade screwdriver can be used to free an obstructed bale clasp on an optical module.

Optical Cables

Direct-attach copper and fiber cables provide connections between populated SFP+, SFP28, QSFP+, and QSFP28 ports.

Install Internal AC Power Supplies

The following AC internal power supplies (PSUs) are available for 5520 Series switches:

350 W AC PSU

Part numbers XN-ACPWR-350W-FB and 10953 provide front-to-back airflow for cooling and are compatible with 5520-24T, 5520-24T-BASE, 5520-24X, 5520-24X-BASE, 5520-48T, 5520-48T-BASE, 5520-48SE, and 5520-48SE-BASE switch models.

Part numbers XN-ACPWR-350W-BF and DPS350AB-42 A provide back-to-front airflow for cooling and are compatible with 5520-24T-BASE, 5520-24X-BASE, 5520-48T-BASE, and 5520-48SE-BASE switch models.

715 W AC PSU

Part numbers XN-ACPWR-715W-FB and 10951 are compatible with 5520-24W, 5520-12MW-36W, and 5520-48W switch models.

1100 W AC PSU

Part numbers XN-ACPWR-1100W-FB and 10941 are compatible with 5520-24W, 5520-12MW-36W, and 5520-48W switch models.

2000 W AC PSU

Part numbers XN-ACPWR-2000W-FB and XN-ACPWR-2000W-F are compatible with 5520-24W, 5520-12MW-36W, and 5520-48W switch models.

For installation instructions, see [Replace Internal AC Power Supplies](#) on page 114.

Connect Network Interface Cables

Use the appropriate type of cable to connect the ports of your switch to another switch or router.

Cable Type	Maximum Distance
CAT5E	55 meters
CAT6	55 meters
CAT6A	100 meters

Working carefully, one port at a time, do the following:

1. Verify that you have identified the correct cable for the port.
2. Use an alcohol wipe or other appropriate cleaning agent to clean the cable connectors; make sure they are free of dust, oil, and other contaminants.
3. If you are using optical fiber cable, align the transmit (Tx) and receive (Rx) connectors with the correct corresponding connectors on the switch or the I/O module.
4. Press the cable connectors into their mating connectors on the switch or I/O module until the cable connector is firmly seated.
5. Repeat the preceding steps for the remaining cables on this or other switches or I/O modules.
6. Dress and secure the cable bundle to provide appropriate strain relief and protection against bends and kinks.

Turn on the Switch

An AC power cord is not included with the AC power supply. You can purchase AC power cords for use in the US and Canada from Extreme Networks or from your local supplier. The cord must meet the requirements listed in [Power Cord Requirements for AC-Powered Switches and AC Power Supplies](#) on page 148.

To turn on an Extreme Networks switch, do the following.

1. For switches that are connected to AC power, connect the power cord to the AC power input socket on the switch (or power supply) and to an AC power outlet.
2. For switches that are connected to DC power, do the following:
 - a. Verify that the DC circuit is de-energized.
 - b. Verify that the ground wire is connected to the grounding lug on the rear of the switch.

The grounding lug is identified by the international symbol for earth ground: 

- c. Verify that the DC power input cables are properly connected to the DC power supplies at the rear of the switch.
 - d. Energize the circuit.
 3. When power is connected, verify that the PSU LED turns green.

When the PSU LED has turned green, follow the instructions in [Connect Network Interface Cables](#) on page 81.

If the PSU and RPS LEDs do not turn green, refer to the *LEDs* topic for your switch model (in [#unique_104](#)) for troubleshooting information.



Activate and Verify the Switch

- [Connect the Switch to a Management Console](#) on page 83
- [Log in for the First Time on Switch Engine](#) on page 83
- [Configure the Switch's IP Address for the Management VLAN](#) on page 85
- [Change the Switch OS via the Bootloader Menu](#) on page 85
- [Change the Switch OS via the Startup Menu](#) on page 86
- [Log In for the First Time on Fabric Engine](#) on page 86

Operating system selection and activation can be done via the following:

1. XIQ - automatically by pre-selecting the preferred switch OS
2. Bootloader menu - option to change the switch OS on initial activation only
3. Startup menu in Switch Engine CLI - post-Bootloader menu prompt

Refer to *Read Me First - Switch OS Selection for Universal Hardware* shipped with your switch, or visit <https://www.extremenetworks.com/support/switch-os-selection/> for information on changing your switch OS after initial activation.

Otherwise, use the instructions in the following topics.

Connect the Switch to a Management Console

Connect each switch's serial console interface (an RJ45 jack) to a PC or terminal. The PC or terminal will serve as the *management console*, used to monitor and configure the switch.

The default communication protocol settings for the serial console interface are:

- Baud rate: 115200
- Data bits: 8
- Stop bit: 1
- Parity: None

Log in for the First Time on Switch Engine

Extreme recommends onboarding your switch with ExtremeCloud™. Log in or create your XIQ administrator account in order to select your switch operating system with XIQ at <https://extremecloudiq.com>

Switch Engine is the default operating system for the 5520 Series. If you want to run Fabric Engine, see [Change the Switch OS via the Bootloader Menu](#) on page 85 or [Change the Switch OS via the Startup Menu](#) on page 86.

Before logging in, verify that the switch LEDs are on (solid green or blinking green) and that it is connected to a management console as described in [Connect the Switch to a Management Console](#) on page 83.

To perform the initial login and complete initial configuration tasks, follow these steps.

1. Using a terminal emulator such as PuTTY or TeraTerm, connect to the switch using the serial port connection. You can also connect to the switch via telnet or SSH.
Be sure that your serial connection is set properly:
 - Baud rate: Baud rate: 115200
 - Data bits: 8
 - Stop bit: 1
2. At the management console, press **[Enter]** one or more times until you see the login prompt.
3. At the login prompt, log in using the default user name `admin`.

For example:

```
login: admin
```

**Note**

For the initial password, simply press **[Enter]**.

When you have successfully logged on to the system, the command line prompt displays the system name (for example, `5520-24T-SwitchEngine#`) in its prompt. You are logged in with administrator privileges, which gives you access to all switch functions.

4. Respond to the screen prompts to configure the level of security you need.

**Note**

For more information about logging in to the switch and configuring switch management access, see the [Switch Engine 32.1 User Guide](#).

5. Enter `show version`.

The switch serial number is displayed, as highlighted in the following example. Make a note of this number for future reference.

```
Transit.3 # show version
Switch : 800444-00-05 0723G-01234 Rev 5.0 BootROM:
```

Configure the switch's IP address for the management virtual LAN (VLAN) by following the steps in [Configure the Switch's IP Address for the Management VLAN](#) on page 85.

Configure the Switch's IP Address for the Management VLAN

You can configure the switch's IP address for the management virtual LAN (VLAN).



Note

The management port is part of the `mgmt` VLAN. This VLAN membership cannot be changed.

Log in to the management console, connect to the switch, and follow these steps.

1. Assign a name, IP address, and default subnetwork mask for the VLAN as shown in the following example.

```
configure vlan vlan_name ipaddress nn.nn.nn.nn 255.255.255.0
```

Your changes take effect immediately.

2. Enter `save` to save your configuration changes so that they will be in effect after the next system reboot.



Note

For more information about saving configuration changes, see the [Switch Engine 32.1 User Guide](#).

The configuration is saved to the configuration database of the switch.

Change the Switch OS via the Bootloader Menu

Onboard your switch with ExtremeCloud™. Log in or create your XIQ administrator account in order to select your switch operating system with XIQ at <https://extremecloudiq.com>.

Switch Engine is the default operating system for the Universal Hardware switch. You can change the switch OS from the Bootloader menu on initial activation only by completing the following steps:

1. Using a terminal emulator such as PuTTY or TeraTerm, connect to the switch using the serial port connection.
Be sure that your serial connection is set properly:
 - Baud rate: Baud rate: 115200
 - Data bits: 8
 - Stop bit: 1
2. Once the switch is powered on, after seeing the "Boot Menu" screen, press the **[spacebar]** key within 30 seconds.
3. Use the **down-arrow** key to select Change the switch OS to Fabric Engine, then select **Enter**.

The switch installs Fabric Engine, then resets. Once the NOS is selected, the "Boot Menu" will only wait for 3 seconds before continuing.

To change the switch OS if you take no action during the initial boot, see [Change the Switch OS via the Startup Menu](#) on page 86.

Change the Switch OS via the Startup Menu

Extreme recommends onboarding your switch with ExtremeCloud™. Log in or create your XIQ administrator account in order to select your switch operating system with XIQ at <https://extremecloudiq.com>.

Switch Engine is the default operating system for the 5520 Series. If you take no action during the initial bootup, you can change the switch OS from the Startup menu on initial activation only by completing the following steps:

1. Connect to the switch via telnet, SSH, or console with a baud rate of 115200.
2. At the login prompt, log in using the default user name `admin`.

For example:

```
login: admin
```



Note

For the initial password, simply press **[Enter]**.

3. The switch prompts you to choose which switch personality you want to use:

```
This switch can alternatively run the Fabric Engine Network Operating System.
If you answer yes, all data including configurations, logs and debugs will be
cleared, except for the license activation status,
Fabric Engine will be installed, and Switch Engine will be removed.
Would you like to change the switch OS to Fabric Engine? [y/N/q]:
```

The switch will install Fabric Engine, then reset.

After resetting, your switch will boot with Fabric Engine. See [Log In for the First Time on Fabric Engine](#) on page 86 for more.

Log In for the First Time on Fabric Engine

Onboard your switch with ExtremeCloud™. Log in or create your XIQ administrator account in order to select your switch operating system with XIQ at <https://extremecloudiq.com>.

To perform the initial login and complete initial configuration tasks, follow these steps.

1. Use a terminal emulator such as PuTTY or TeraTerm to connect to the switch through the serial port connection.

You can also connect to the switch via telnet or SSH. Be sure that your serial connection is set properly:

- Baud rate: 115200
- Data bits: 8
- Stop bit: 1

2. Press **[Enter]** one or more times until you see the login prompt.

3. At the login prompt, log in using the default user name `rwa`.

For example:

```
login: rwa
```

When prompted for the password, enter `rwa`.

When you are logged in with the role-based authentication level of `rwa`, you can configure the login and password values for the other role-based authentication levels.



Install Expansion Modules

[Install a V300 Virtual Port Extender](#) on page 88

[Install a V400 Virtual Port Extender](#) on page 109

[Install a Half-Duplex to Full-Duplex Converter](#) on page 110

[Install a Versatile Interface Module in a 5520 Series Switch](#) on page 112

This chapter describes how to install expansion modules:

- The V300 Virtual Port Extender
- The V400 Virtual Port Extender
- The LRM/MACsec Adapter
- The Half-Duplex to Full-Duplex Converter
- Versatile interface modules (5520-VIMs)



Note

Read the information in this chapter thoroughly before trying install or remove an expansion module.

Install a V300 Virtual Port Extender

The following installation instructions are applicable to the V300-8P-2T-W (PoE) model. The V300-8P-2X, V300-8T-2X, V300HT-8P-2X, and V300HT-8T-2X models will be referred to as non-PoE models from this point on.

You need the following tools and materials to install a V300 Virtual Port Extender:

- ESD-preventive wrist strap
- M3.5 or M4 #2 Phillips screwdriver (magnetic screwdriver recommended)

The V300 Virtual Port Extender comes with two mounting brackets and screws for attaching them. Mount the equipment in a standard equipment rack, in either a front-mount or mid-mount configuration, in the same way you would mount a switch.

To install a V300 Virtual Port Extender, follow these steps:

1. Attach the mounting brackets to the sides of the port extender using four screws (included) for each bracket.
2. Align the holes in the brackets with the rack post holes.
3. Secure the port extender to each post with rack-mounting screws (not provided).
4. Connect an AC power cord to the AC power input socket on the port extender and to an AC power outlet.

5. When power is connected, verify that the SYS LED on the port extender turns green. If the SYS LED does not turn green, verify that the power source is on and the connection was made properly.
6. Optionally, connect the port extender to a redundant power source, depending on the model.

The following mounting kits are available for non-PoE V300 models:

Table 25: V300 Mounting Kits

Kit part number	Description
XN-2P-RMTKIT-1CS-001	Single rack mount kit
XN-2P-RMTKIT-2CS-001	Dual rack mount kit
XN-DIN-MT-001	DIN Rail mount kit
XN-MTKIT-CS-001	Replacement surface mount kit
XN-PS-MT-001	PSU mount kit

For additional installation options, including non-PoE V300 Mounting Kit installation, see the following topics:

- [Install a V300 Virtual Port Extender on a Wall](#) on page 89
- [Install a V300 Virtual Port Extender Under or on a Table Surface](#) on page 92
- [Install a V300 Virtual Port Extender in a VESA Mount](#) on page 94
- [Install a V300 in a Single Rack Mount](#) on page 96
- [Install a V300 in a Dual Rack Mount](#) on page 99
- [Install a V300 in a DIN Rail Mount](#) on page 102
- [Install a V300-8P-2T-W Model in a Single or Dual Rack Mount](#) on page 105
- [Installing a V300-8P-2T-W Model in a DIN Rail Mount](#) on page 106

Install a V300 Virtual Port Extender on a Wall

The following tools and materials are required to install a V300 Virtual Port Extender to a wall:

- ESD-preventive wrist strap
- M3.5 #2 Phillips screwdriver (magnetic screwdriver recommended)
- M4 #2 Phillips screwdriver (magnetic screwdriver recommended) for non-PoE models



Note

The mounting surface, item, and hardware must be able to support the extender in all environmental conditions. The mounting surface must also be flat.

Typical installation for the V300-8P-2T-W model include wall or table installations, in addition to VESA mounting.

There are several orientations for installation on a wall. To install the V300-8P-2T-W model on a wall:

1. Attach the short brackets to both sides of the extender

The orientation for wall mounting should be front panel facing down.

Two short brackets attached to the extender by 4 wood screws and 4 anchors, provided in the accessory kit.

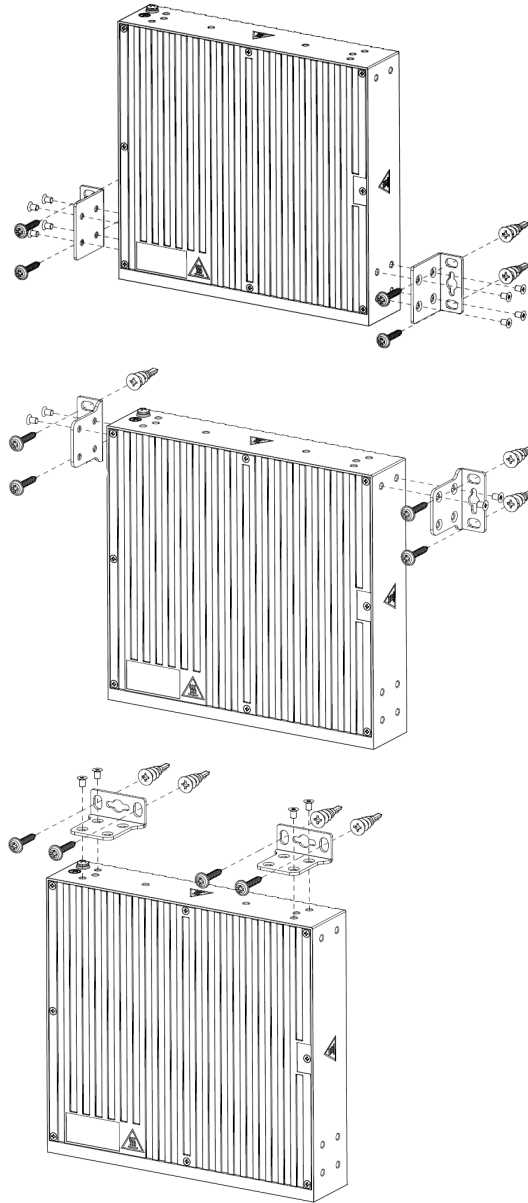

Figure 47: V300-8P-2T-W Wall Mounting

2. Use the optional short bracket as a template and mark the holes to be used. Extreme recommends using 2 holes per short rack ear.

3. For non-PoE models, after attaching the short brackets, attach the PSUs to the PSU mounting brackets using two cable ties.

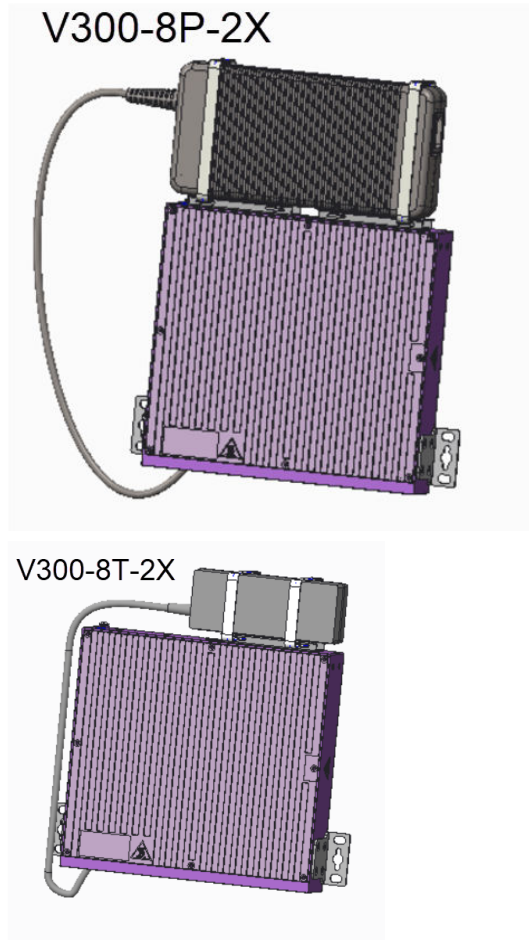

Figure 48: V300-8P/8T-2X Wall Mount with PSU

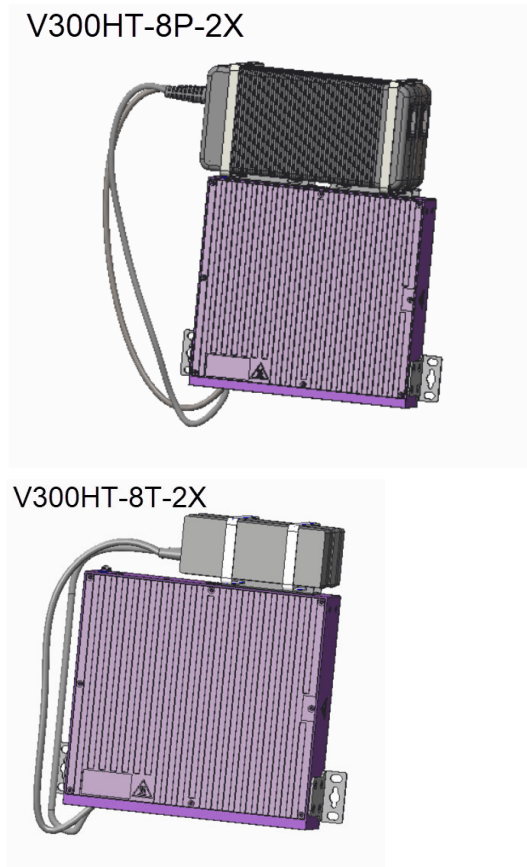

Figure 49: V300HT-8P/8T-2X Wall Mount with PSU

4. Drill the holes and attach the bracket using the provided woodscrews and anchors.
5. Connect the LAN/Ethernet cables to the extender.
6. When power is connected, verify that the SYS LED on the port extender turns green.

Install a V300 Virtual Port Extender Under or on a Table Surface

The following tools and materials are required to install a V300 Virtual Port Extender under a table:

- ESD-preventive wrist strap
- M3.5 #2 Phillips screwdriver (magnetic screwdriver recommended) for PoE model
- M4 #2 Phillips screwdriver (magnetic screwdriver recommended) for non-PoE models

Typical installation for the V300-8P-2T-W model include wall or table installations, in addition to VESA mounting.

For table surface or other flat surface installation, attach the rubber feet to the underside of the virtual port extender, then place the device to the table or flat surface:

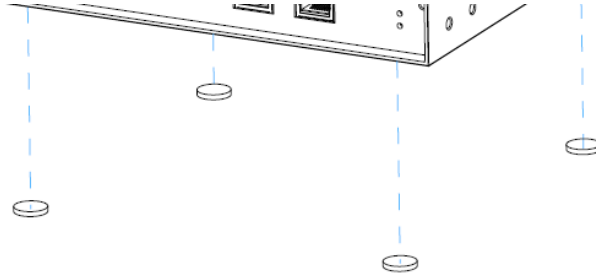

Figure 50: Table Surface Mounting

There are several orientations for installation under a table. To install a V300-8P-2T-W model under a table:

1. Attach the short mounting brackets (included in kit) to the sides of the port extender using four screws (included) for each bracket.

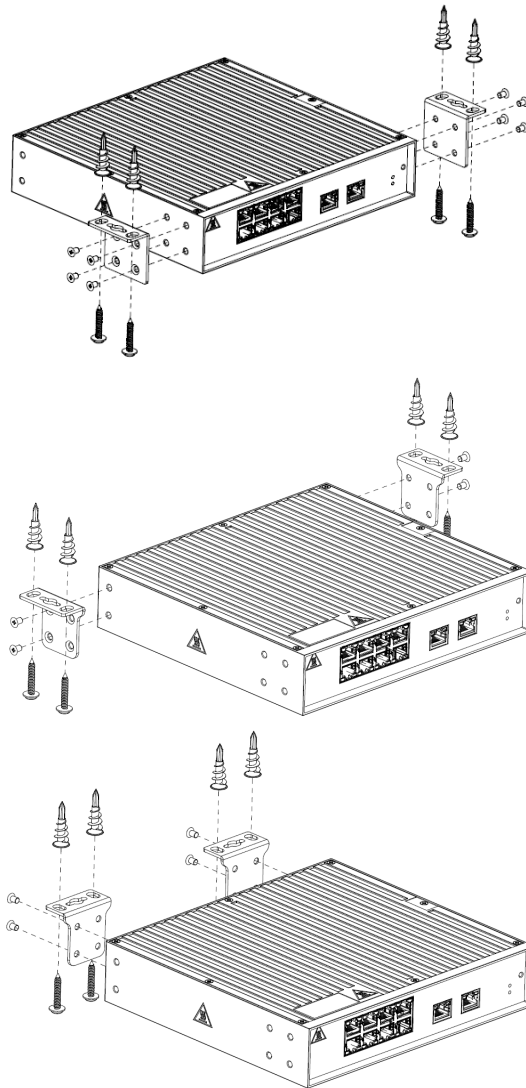
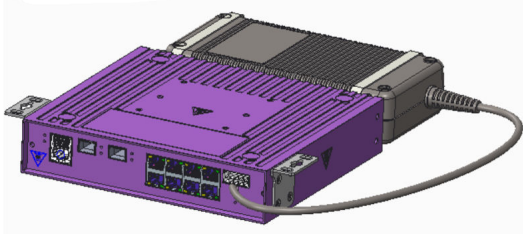

Figure 51: Under Table Mounting

- For non-PoE models, after attaching short brackets and PSU bracket to the V300, attach the PSU(s) to the PSU mounting bracket using two cable ties:

V300-8P-2X

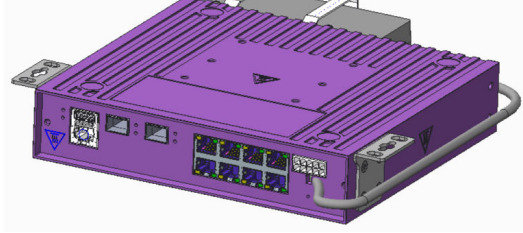

V300-8T-2X

**Figure 52: V300-8P/8T-2X Under Table Mounting with PSU**

V300HT-8P-2X

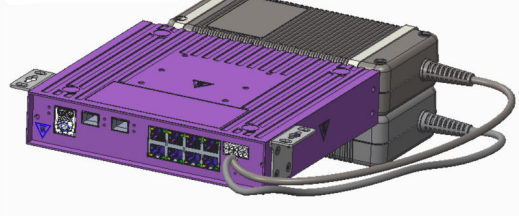

V300HT-8T-2X

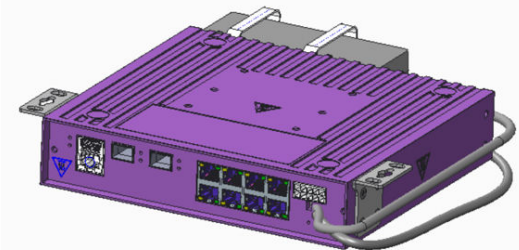
**Figure 53: V300HT-8P/8T-2X Under Table Mounting with PSU**

- Secure the port extender to the underside of the table using the provided 4 wood screws and 4 anchors.
- When power is connected, verify that the SYS LED on the port extender turns green.

Install a V300 Virtual Port Extender in a VESA Mount

The following tools and materials are required to install a V300 Virtual Port Extender with a VESA mount:

- ESD-preventive wrist strap

- M4 #2 Phillips screwdriver (magnetic screwdriver recommended)

The VESA mount comes with 4 screws and should be used when mounting the V300 Virtual Port Extender to a VESA mount for 75mm x 75mm or 35mm x 75mm mounting dimensions. To install a V300 Virtual Port Extender in a VESA Mount:

1. Attach the VESA mount to the underside of the port extender using four screws (included):

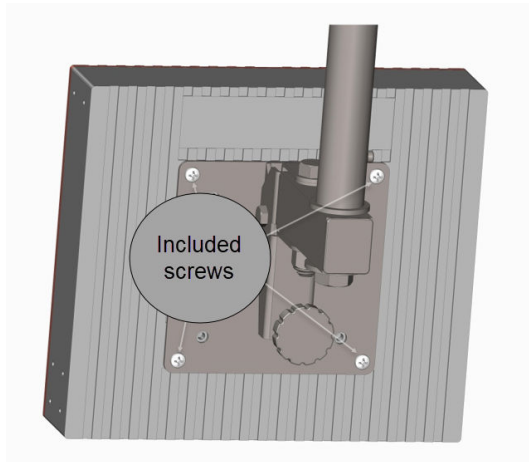
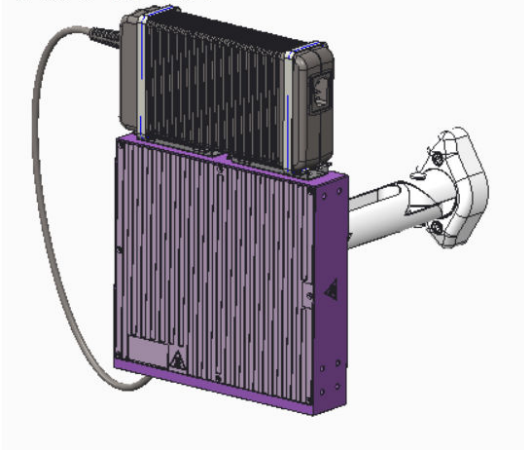

Figure 54: VESA Mounting

- For non-PoE models, after attaching the PSU bracket to the V300, attach the PSU(s) to the PSU mounting brackets using two cable ties:

V300-8P-2X



V300-8T-2X

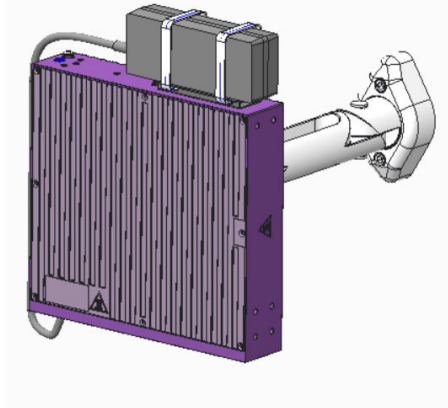

Figure 55: V300-8P/8T-2X VESA Mounting with PSU

- Connect the LAN/Ethernet cables to the extender.
- When power is connected, verify that the SYS LED on the port extender turns green.

Install a V300 in a Single Rack Mount

The following tools and materials are required to install a non-PoE V300 Virtual Port Extender to a single rack mount:

- ESD-preventive wrist strap
 - M4 #2 Phillips screwdriver (magnetic screwdriver recommended)
 - XN-2P-RMTKIT-1CS-001 - Single rack mount kit
- Remove all contents of the single rack mount kit (XN-2P-RMTKIT-1CS-001).
 - Attach the short and long ear brackets to the V300 using the screws provided.
 - Secure the bracket flanges to the rack using the customer-provided screws appropriate for the rack you are using.

4. After attaching the PSU bracket to the V300, attach the PSU to the PSU mounting brackets using two or four cable ties:



Figure 56: V300-8P-2X Single Rack Mounting with PSU

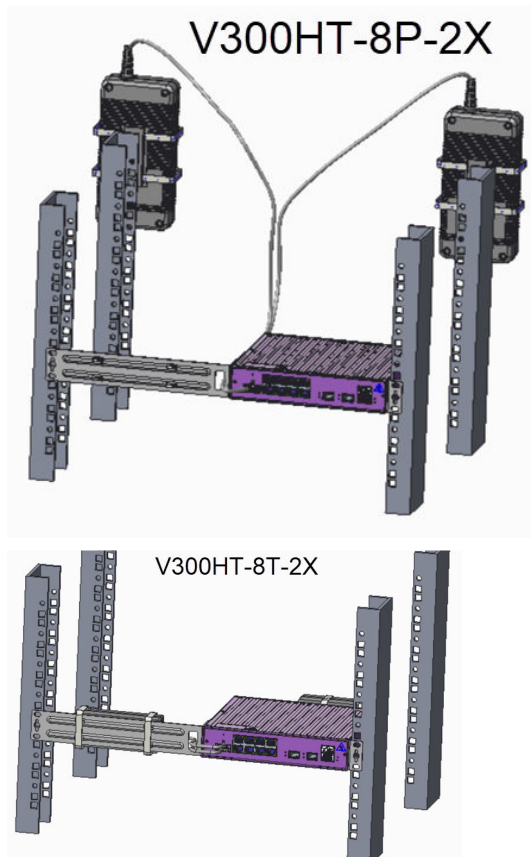

Figure 57: V300HT-8P/8T-2X Single Rack Mounting with PSUs

- For a more secure attachment, attach the two PSU mounting brackets to the rack using customer-provided screws:

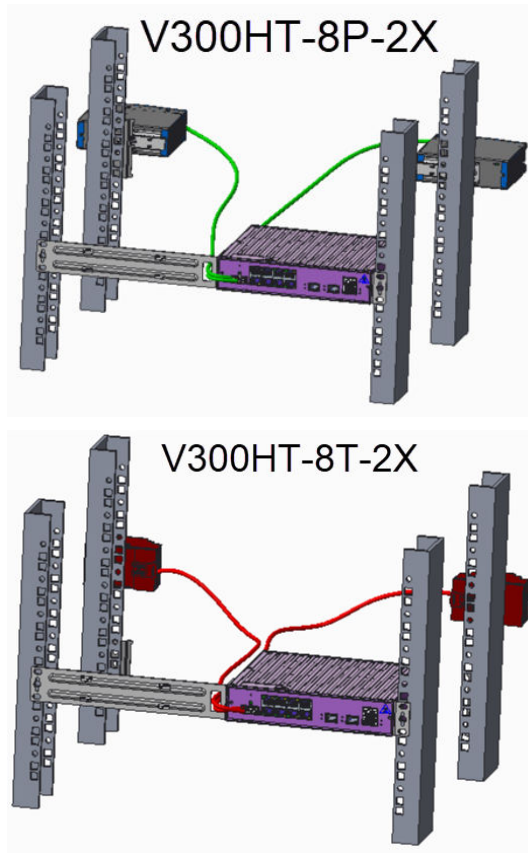

Figure 58: V300HT-8P/8T-2X Single Rack Mounting with DIN Rail and PSUs

- Alternatively, the PSU can be mounted to the long rack ear using cable ties.

Install a V300 in a Dual Rack Mount

The following tools and materials are required to install a non-PoE V300 Virtual Port Extender to a dual rack mount:

- ESD-preventive wrist strap
 - M4 #2 Phillips screwdriver (magnetic screwdriver recommended)
 - XN-2P-RMTKIT-2CS-001 - Dual rack mount kit
- Remove all contents of the dual rack mount kit (XN-2P-RMTKIT-2CS-001).
 - Attach one short ear bracket to the outer side of each V300 using the screws provided.
 - Attach the joint brackets to the inward side of each V300 (one with tapped screw holes facing forward, one facing rearward, using the screws provided).
 - Attach the two joint brackets together using the screws provided.

5. After attaching the PSU bracket to the V300 using the provided screws, attach the PSU to the PSU mounting brackets using two, four, or eight cable ties:

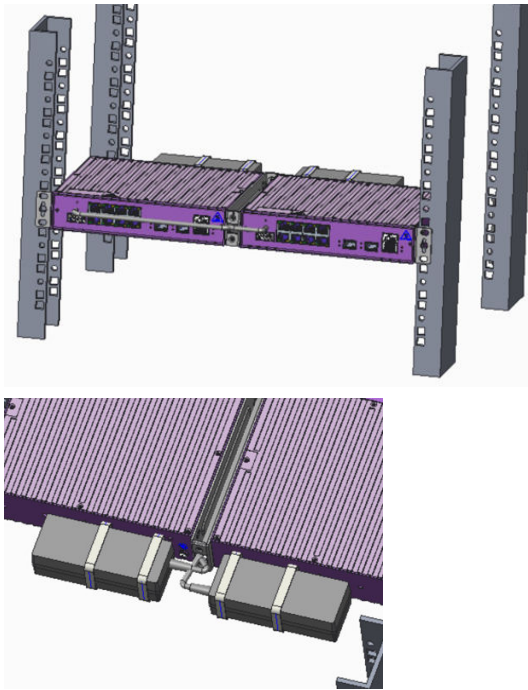

Figure 59: V300-8T-2X Dual Rack Mounting with PSU

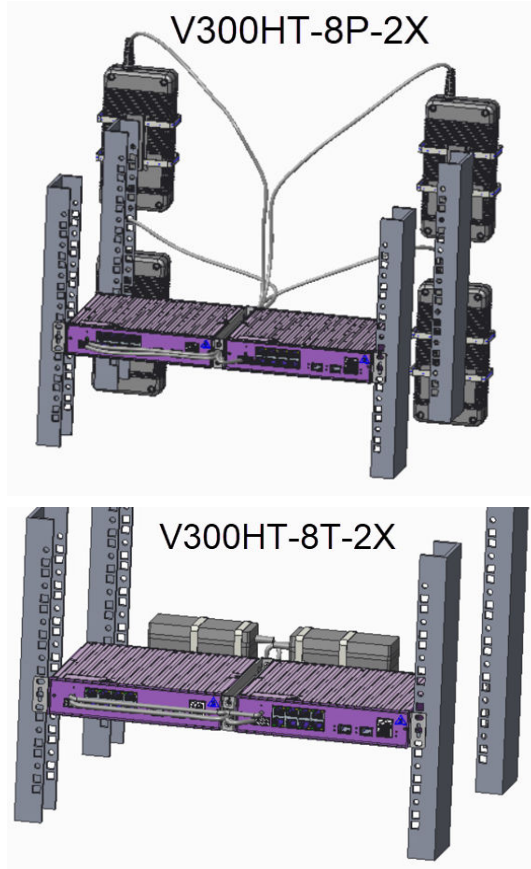

Figure 60: V300HT-8P/8T Dual Rack Mounting with PSUs

6. For a more secure attachment, attach the PSU mounting brackets to the rack using customer-provided screws:

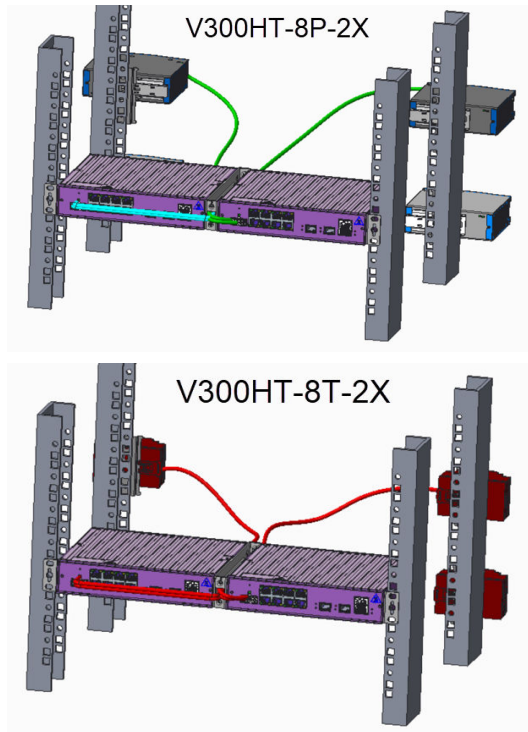

Figure 61: V300HT-8P/8T Dual Rack Mounting with DIN Rail and PSUs

Install a V300 in a DIN Rail Mount

The following tools and materials are required to install a non-PoE V300 Virtual Port Extender to a DIN Rail mount:

- ESD-preventive wrist strap
- M4 #2 Phillips screwdriver (magnetic screwdriver recommended)
- XN-DIN-MT-001 - DIN Rail mount kit

For PSU XN-ACPWR-320W-HT or XN-ACPWR-40W-HT:

1. Remove all contents of the DIN Rail mount kit (XN-DIN-MT-001).
2. Attach the port extender to the DIN Rail using one DIN bracket and the screws provided.

3. Attach the PSUs to the DIN bracket using cable ties, and then attach the bracket to the DIN Rail:

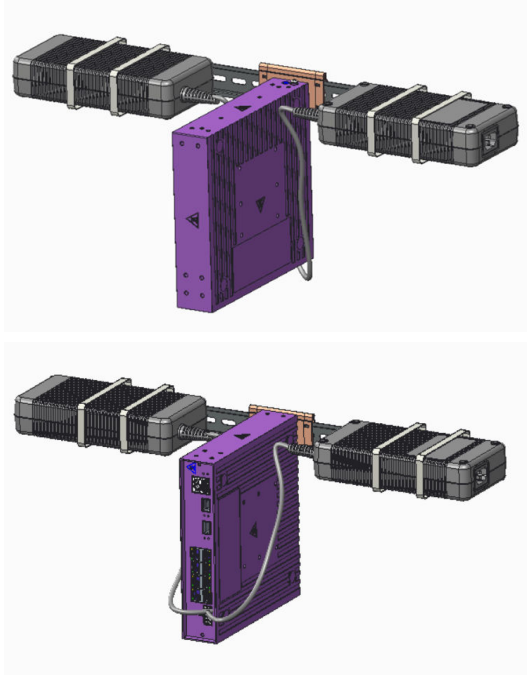

Figure 62: V300HT-8P-2X DIN Rail Mount with dual XN-ACPWR-320W-HT PSUs

4. For PSU 16807, attach the port extender to the DIN Rail using one DIN bracket and the screws provided.

5. Attach the PSUs directly to the DIN rail:

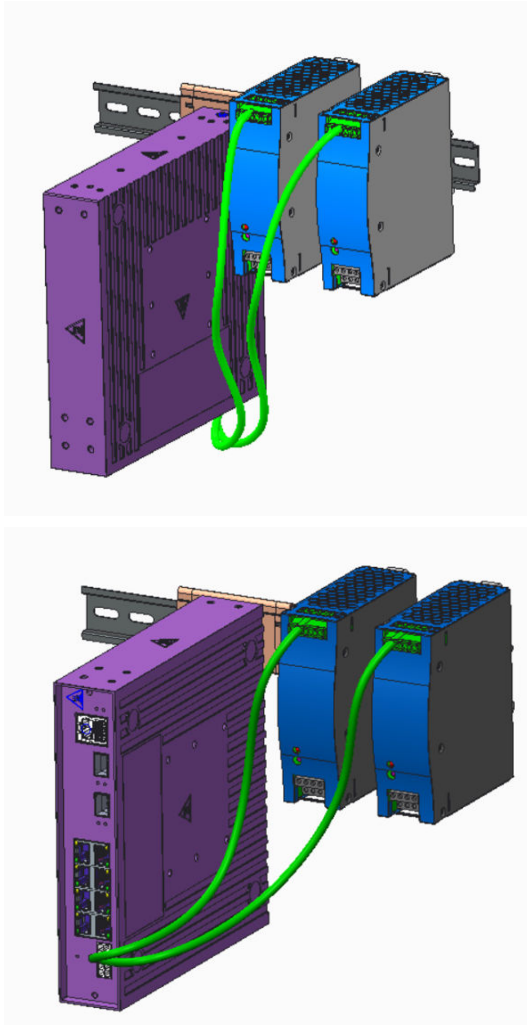

Figure 63: V300HT-8P-2X DIN Rail Mount with dual 16807 PSUs

6. For XN-ACPWR-60W-HT-DIN, attach the port extender to the DIN Rail using one DIN bracket and the screws provided.

- Attach the PSUs directly to the DIN rail:

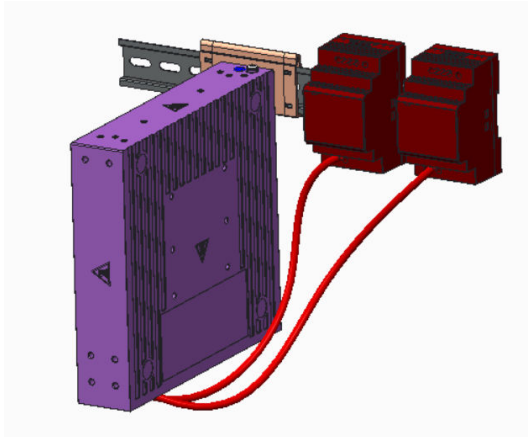

Figure 64: V300HT-8T-2X DIN Rail Mount with dual XN-ACPWR-60W-HT-DIN PSUs

Install a V300-8P-2T-W Model in a Single or Dual Rack Mount

You need the following tools and materials to install a V300-8P-2T-W model to a rack mount:

- ESD-preventive wrist strap
- M4 #2 Phillips screwdriver (magnetic screwdriver recommended)

Typical installation for the V300-8P-2T-W model include wall or table installations, in addition to VESA mounting. In order to rack-mount this model, an accessory mounting kit is required.

To install the V300-8P-2T-W model in a single or dual rack mount kit:

1. Remove all contents of the single rack mount kit (XN-1S-RKMT-V300) or dual rack mount kit (XN-2S-RKMT-V300).
2. Attach the short mounting brackets (included) to the sides of the port extender using the four screws (included) for each bracket.

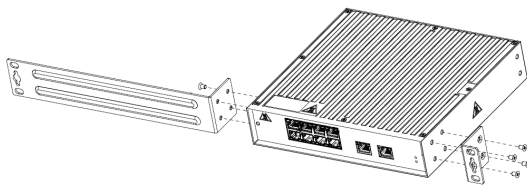

Figure 65: Single Rack Mounting

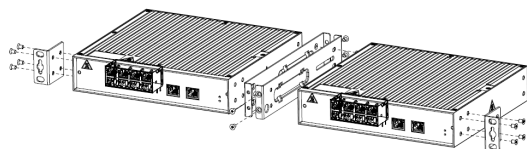

Figure 66: Dual Rack Mounting

3. Align the holes in the brackets with the rack post holes.
4. Secure the port extender to each post with rack-mounting screws (not provided).
5. Connect the LAN/Ethernet cables to the extender.
6. When power is connected, verify that the SYS LED on the port extender turns green.

Installing a V300-8P-2T-W Model in a DIN Rail Mount

You need the following tools and materials to install a V300 Virtual Port Extender to a DIN Rail mount:

- ESD-preventive wrist strap
- M4 #2 Phillips screwdriver (magnetic screwdriver recommended)

There are two DIN Rail mounting options. To install a V300-8P-2T-W model in a DIN Rail Mount:

1. Remove all contents of the DIN Rail Mount Kit (XN-DIN-MT-V300).
2. For option 1, attach the DIN mounting bracket to the rear of the port extender using the two screws (included) for each bracket:

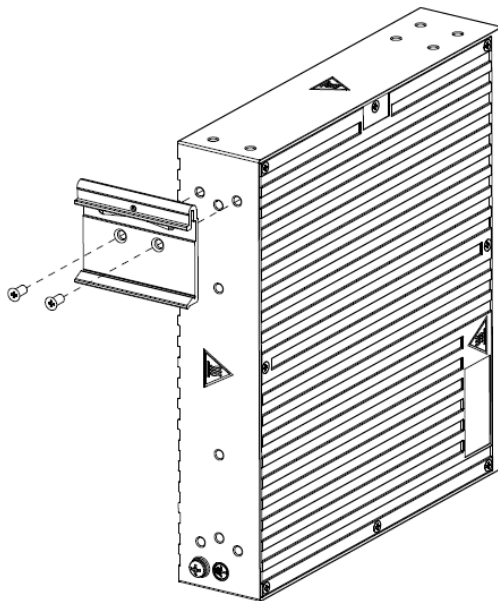

Figure 67: DIN Rail Mounting Option 1: Attach the Bracket

3. Align the DIN bracket with the DIN rail and attach the port extender:

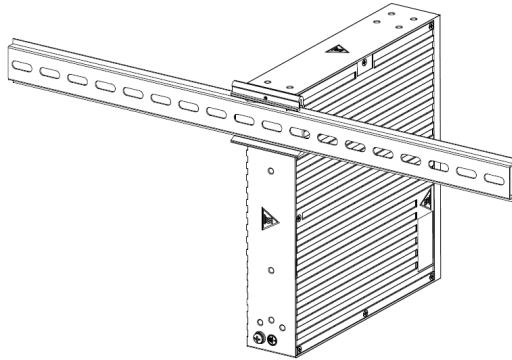

Figure 68: DIN Rail Mounting Option 1: Secure the Port Extender

4. For option 2, attach the DIN mounting bracket to the side panel of the port extender:

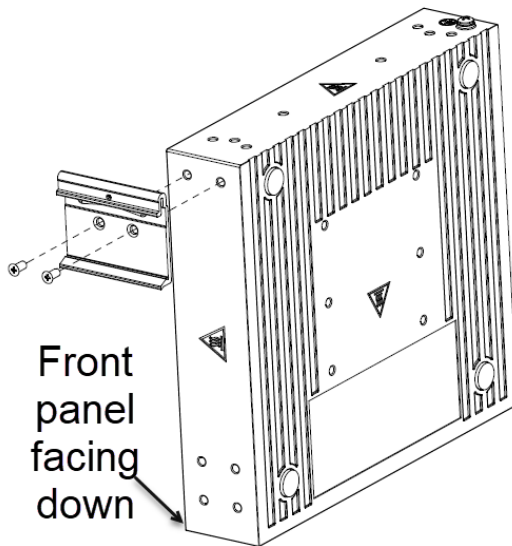

Figure 69: Din Rail Mounting Option 2: Attach the Bracket

5. Align the DIN bracket with the DIN rail and attach the port extender:

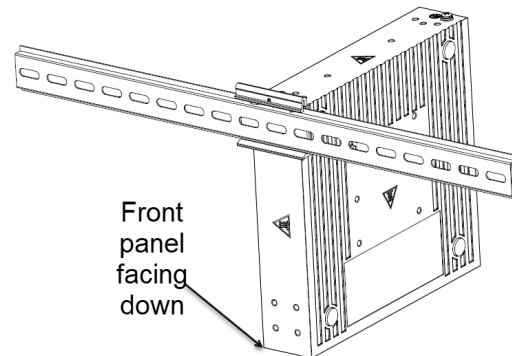

Figure 70: DIN Rail Mounting Option 2: Secure the Port Extender

6. When power is connected, verify that the SYS LED on the port extender turns green.

Connecting the V300 Virtual Port Extender to Power

V300-8P-2W and V300-8T-2W models run on AC power with included power supply unit(s).

V300HT-8P-2W and V300HT-8T-2W models can run on redundant power supplies (RPS). HT model power supplies are sold separately.

See the following topics to connect non-PoE V300 models to power:

- [Connect the V300 to a Primary Power Source](#) on page 108
- [Connect the V300 to a Redundant Power Source](#) on page 109

Connect the V300 to a Primary Power Source



Note

Installing the system as described in this guide meets the protective earth grounding requirements of the National Electrical Code (NEC) UL 60950 and IEC 60950 standards. However, in some cases, it may be necessary to use an alternative grounding method. In these cases, a 14 AWG wire can be connected between the grounding lug on the chassis and a nearby building ground point.

To attach the V300 switch to a power source, do the following:

1. Connect the PSU to the V300 with the integrated power cable.
2. Connect the AC power cord to the AC power input socket on the power supply and plug the other end into an AC power outlet.

To attach the V300HT model to a primary power source, do the following:

3. Connect the PSU to the included screw terminal connector (use adequate AWG wire for DIN PSUs).
4. Plug the screw terminal connector into the port extender DC input (PSU1 recommended).
5. Connect the:
 - AC power cord to the AC power input socket on the PSU and plug the other end into an AC power outlet for non-DIN PSUs; or
 - PSU to an AC power source using the instructions included with the PSU for DIN PSUs.

When power is connected, verify that the PWR LED on the switch turns green. If the PWR LED does not turn green, verify that the power source is powered on and the connection was made properly.

Connect the V300 to a Redundant Power Source

**Note**

Installing the system as described in this guide meets the protective earth grounding requirements of the National Electrical Code (NEC) UL 60950 and IEC 60950 standards. However, in some cases, it may be necessary to use an alternative grounding method. In these cases, a 14 AWG wire can be connected between the grounding lug on the chassis and a nearby building ground point.

To attach the V300 switch to a redundant power source (HT models only), do the following:

1. Connect the RPS to the included screw terminal connector (use adequate AWG wire for DIN PSUs).
2. Plug the screw terminal connector into the port extender DC input (PSU2 recommended).
3. Connect the:
 - AC power cord to the AC power input socket on the PSU and plug the other end into an AC power outlet for non-DIN PSUs; or
 - PSU to an AC power source using the instructions included with the PSU for DIN PSUs.

When power is connected, verify that the PWR LED on the switch turns green. If the PWR LED does not turn green, verify that the power source is powered on and the connection was made properly.

Install a V400 Virtual Port Extender

You need the following tools and materials to install a V400 Virtual Port Extender:

- ESD-preventive wrist strap
- #1 Phillips screwdriver (for clock module) or flat-bladed screwdriver (for all other VIM modules)

Your V400 Virtual Port Extender comes with two mounting brackets and screws for attaching them. Mount the equipment in a standard equipment rack, in either a front or mid-mount configuration, in the same way you would mount a switch.

To install a V400 Virtual Port Extender, follow these steps:

1. Attach the mounting brackets to the sides of the port extender using four screws (included) for each bracket.
2. Align the holes in the brackets with the rack post holes.
3. Secure the port extender to each post with rack-mounting screws (not provided).
4. Connect an AC power cord to the AC power input socket on the port extender and to an AC power outlet.
5. When power is connected, verify that the SYS LED on the port extender turns green. If the SYS LED does not turn green, verify that the power source is powered on and the connection was made properly.

Install a Half-Duplex to Full-Duplex Converter

The following options are available for installing the Half-Duplex to Full-Duplex Converter:

1. On a shelf that is mounted in an equipment rack. (The shelf can accommodate up to three converters.)

See [Installing Half-Duplex to Full-Duplex Converters in a 3-Slot Modular Shelf](#) on page 110.

2. On a flat surface.

See [Mounting a Half-Duplex to Full-Duplex Converter on a Flat Surface](#) on page 110.

3. On a wall.

See [Mounting a Half-Duplex to Full-Duplex Converter on a Wall](#) on page 111.

Installing Half-Duplex to Full-Duplex Converters in a 3-Slot Modular Shelf

Refer to [Install a Half-Duplex to Full-Duplex Converter](#) on page 110 for installation options for the Half-Duplex to Full-Duplex Converter.

Before installing the converter in the 3-slot modular shelf (part no. STK-RPS-1005CH3), mount the shelf in the rack. Follow the steps in the [3-Slot Modular Shelf Quick Reference Guide](#).

To install up to three Half-Duplex to Full-Duplex Converter units in the 3-slot modular shelf, follow these steps:

1. Attach the four rubber feet (included) to the bottom of the converter, one at each corner.
2. Set the converter on the shelf.
3. Connect the converter to its power adapter, following the instructions in [Connecting a Half-Duplex to Full-Duplex Converter to its Power Adapter](#) on page 111.
4. Secure the converter to the shelf using cable ties (included with the shelf).
Pass the ties through the holes in the shelf and secure them firmly around the converter.
5. Connect the full-duplex ports (FD1 - FD4) to the switch.
6. Connect the half-duplex ports (HD1 - HD4) to your half-duplex devices.
7. Install one or two additional Half-Duplex to Full-Duplex Converter units in the shelf, as described in steps 1 on page 110 through 4.

Mounting a Half-Duplex to Full-Duplex Converter on a Flat Surface

Refer to [Install a Half-Duplex to Full-Duplex Converter](#) on page 110 for installation options for the Half-Duplex to Full-Duplex Converter.

To install a Half-Duplex to Full-Duplex Converter unit on a flat surface, follow these steps:

1. Attach the four rubber feet (included) to the bottom of the converter, one at each corner.
2. Set the converter on a flat, stable surface.
3. Connect the converter to its power adapter, following the instructions in [Connecting a Half-Duplex to Full-Duplex Converter to its Power Adapter](#) on page 111.
4. Connect the full-duplex ports (FD1 - FD4) to the switch.
5. Connect the half-duplex ports (HD1 - HD4) to your half-duplex devices.

Mounting a Half-Duplex to Full-Duplex Converter on a Wall

Refer to [Install a Half-Duplex to Full-Duplex Converter](#) on page 110 for installation options for the Half-Duplex to Full-Duplex Converter.

To mount a Half-Duplex to Full-Duplex Converter unit on a wall, follow these steps:

1. Drill two holes in the wall, each 4 mm (0.16 in.) in diameter.
The holes should be 10.5 cm (4.13 in.) apart so that they correspond to the locations of the holes in the bottom of the converter.
2. Insert an anchor bolt (not provided) into each hole in the wall.
3. Place a screw (not provided) into each anchor bolt and tighten so that the screw head protrudes slightly from the wall.
4. Place the converter onto the screws and gently lower it so that it locks into place.
5. Connect the converter to its power adapter, following the instructions in [Connecting a Half-Duplex to Full-Duplex Converter to its Power Adapter](#) on page 111.
6. Connect the full-duplex ports (FD1 - FD4) to the switch.
7. Connect the half-duplex ports (HD1 - HD4) to your half-duplex devices.

Connecting a Half-Duplex to Full-Duplex Converter to its Power Adapter

Before connecting the Half-Duplex to Full-Duplex Converter to power, install it using one of the options described in [Install a Half-Duplex to Full-Duplex Converter](#) on page 110.

The Half-Duplex to Full-Duplex Converter operates on DC power, which it receives from its power adapter.

Connection points to the power adapter are located on the sides of the converter, as shown in [Figure 71](#).

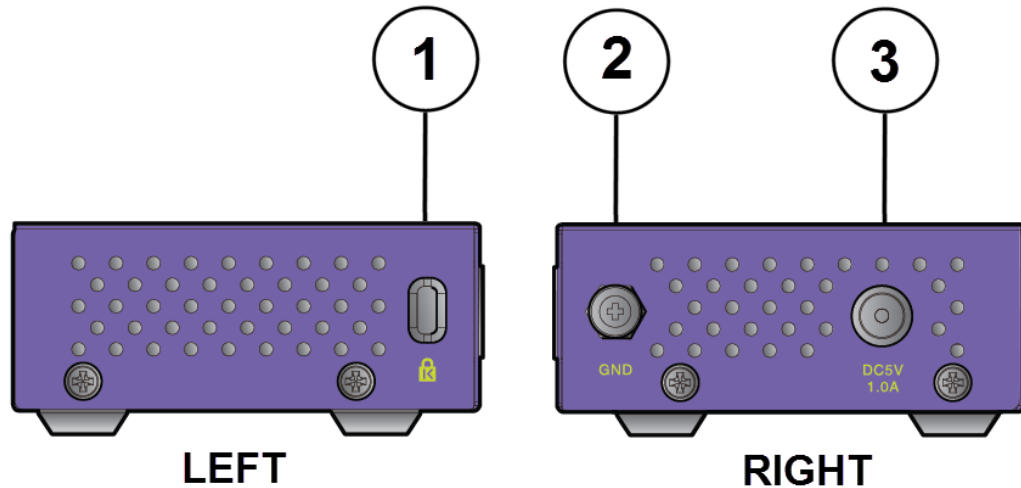

Figure 71: Half-Duplex to Full-Duplex Converter: Side Panels

1 = Kensington lock point	3 = DC power connector
2 = Grounding point	

To connect your Half-Duplex to Full-Duplex Converter to power, follow these steps:

1. Attach a grounding wire to the grounding point on the side of the converter.
2. Connect a DC power cable to the DC input socket on the same side of the converter.
3. Connect the other end of the DC power cable to the power adapter.
4. Connect the power adapter to an AC power source.
5. When power is connected, verify that the converter's power LED turns green.

If the power LED does not turn on, recheck the connections from the connector to the power source.

Install a Versatile Interface Module in a 5520 Series Switch

This section describes how to install a versatile interface module (VIM) in the front slot of a 5520 Series switch.

You need the following tools and materials to install a VIM:

- ESD-preventive wrist strap
- Flat head screwdriver



Caution

Extreme Networks VIMs are not hot-swappable. Disconnect power to the switch before removing an installed VIM or installing a new VIM.

To install a versatile interface module, follow these steps:

1. Attach the ESD wrist strap to your wrist and connect the metal end to an appropriate ground point on the rack.

2. Ensure that the switch is completely powered down.
3. Using two fingers, remove the cover plate from the VIM slot.
 - a. Squeeze the sides to release the plate, and pull down from the top to open. The plate will remain attached at the bottom.

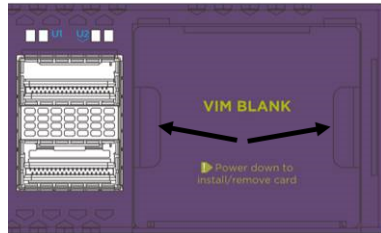

Figure 72: Removing a slot Cover Plate (VIM slot cover shown)

4. Remove the new VIM from its anti-static packaging.
5. Install the VIM in the switch:
 - a. Carefully slide the VIM module into the switch.
 - b. Insert and tighten the retaining screws you previously removed, using the screws provided.

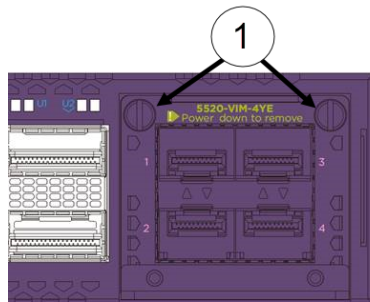

Figure 73: Tighten Screws on the Inserted VIM Module

1 = VIM module retaining screw locations



Replace Internal AC Power Supplies

[Replace a 350 W or 715 W AC Power Supply](#) on page 114

[Replace an 1100 W AC Power Supply](#) on page 116

[Replace a 2000 W AC Power Supply](#) on page 118

This topic describes how to replace internal AC power supplies in a switch.



Caution

Power supplies that support PoE cannot be installed in switches that do not support PoE. The switch operating system prevents PoE power contribution from a power supply that is not listed for use with that particular switch model.

Replace a 350 W or 715 W AC Power Supply

The 350 W AC power supplies with part numbers XN-ACPWR-350W-FB or 10953 provide front-to-back airflow for cooling and are compatible with 5520-24T, 5520-24X, 5520-48T, and 5520-48SE models.

The 350 W AC power supplies with part numbers XN-ACPWR-350W-BF or DPS350AB-42 A provide back-to-front airflow for cooling and are compatible with 5520-24T-BASE, 5520-24X-BASE, 5520-48T-BASE, and 5520-48SE-BASE models.

All installed power supplies must blow air in the same direction and must match the airflow direction of the installed fan modules.

The 715 W AC power supplies with part numbers XN-ACPWR-715W-FB or 10951 are compatible with 5520-24W, 5520-12MW-36W, and 5520-48W models.

These switches have two bays for hot-swappable power supplies. In a switch with a redundant power configuration, you can replace one AC power supply without powering down the switch.

You need the following tools and materials to replace a 350 W or 715 W AC power supply:

- Thermal protective gloves
- AC power cord, if you will not be re-using the cord from the removed power supply

To replace a 350 W or 715 W AC power supply, follow these steps:

1. Disconnect the AC power cord from the wall outlet and from the power supply.

2. Note the orientation of the installed power supply, and the location of the latching tab at the right of the unit.
3. Push the latching tab toward the power supply handle and pull outward on the handle to disengage the power supply internal connectors.

See [Figure 74](#).

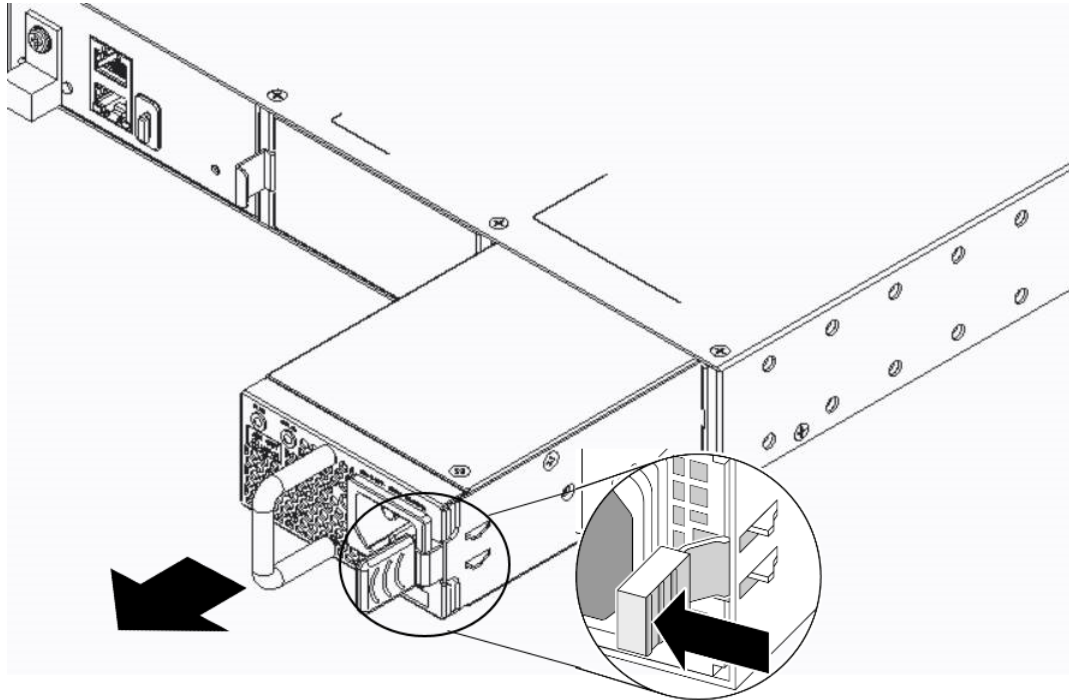

Figure 74: Removing a 350 W or 715 W AC Power Supply

4. Carefully slide the power supply the rest of the way out of the switch.



Caution

Power supplies can become very hot during operation. Wear thermal protective gloves when you remove a power supply from an operating switch.



Note

If you are not installing a replacement power supply, install a cover over the unoccupied power supply bay. Unoccupied bays must always be covered to maintain proper system ventilation and EMI levels.

5. Verify that the replacement power supply is oriented the same way as the unit you removed, and has the same airflow direction.
6. Carefully slide the power supply all the way into the power supply bay, as shown in [Figure 75](#).

7. Push the power supply in until the latch snaps into place.

**Caution**

Do not slam the power supply into the switch.

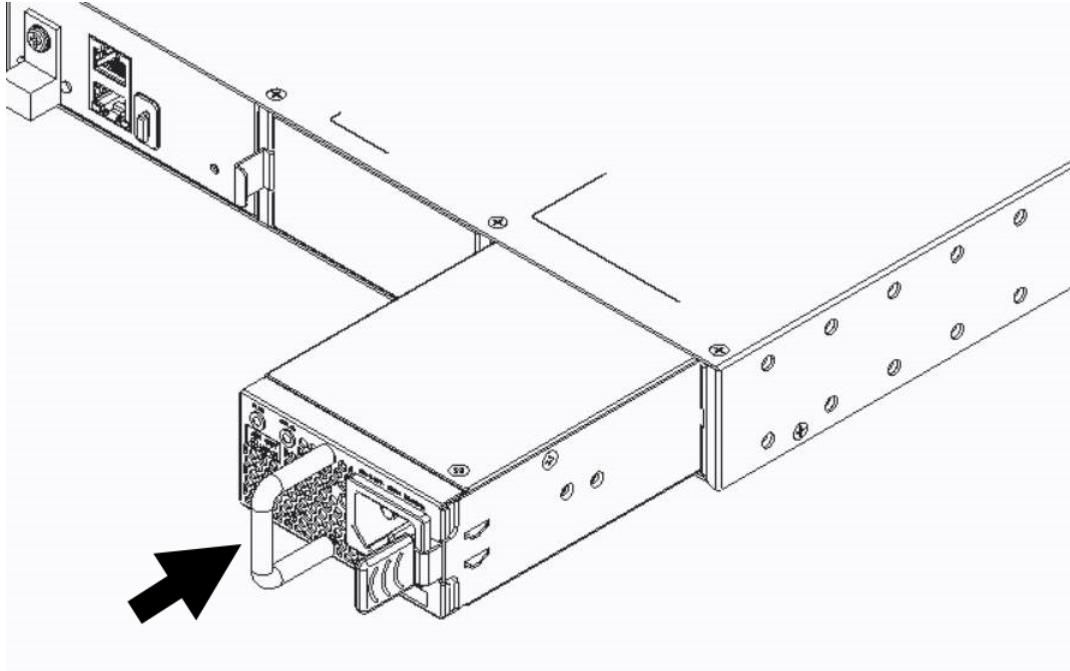

Figure 75: Installing A 350 W or 715 W AC Power Supply

8. Connect the power cord to the power supply and to a grounded AC power outlet.

**Warning**

Always be sure that the source outlet is properly grounded before plugging the AC power cord into the AC power supply.

9. If the power supply is equipped with a power cord retainer, use the retainer to secure the power cord to the power supply.

Replace an 1100 W AC Power Supply

The 1100 W AC power supplies with part numbers XN-ACPWR-1100W-FB or 10941 are compatible with 5520-24W, 5520-12MW-36W, and 5520-48W models.

The switches have two bays for hot-swappable power supplies. In a switch with a redundant power configuration, you can replace one AC power supply without powering down the switch.

You need the following tools and materials to replace a 1100 W AC power supply:

- Thermal protective gloves
- AC power cord, if you will not be re-using the cord from the removed power supply

To replace a 1100 W AC power supply, follow these steps:

1. Disconnect the AC power cord from the wall outlet and from the power supply.
2. Note the orientation of the installed power supply, and the location of the latching tab at the right of the unit.
3. Push the latching tab toward the power supply handle and pull outward on the handle to disengage the power supply internal connectors.

See [Figure 76](#).

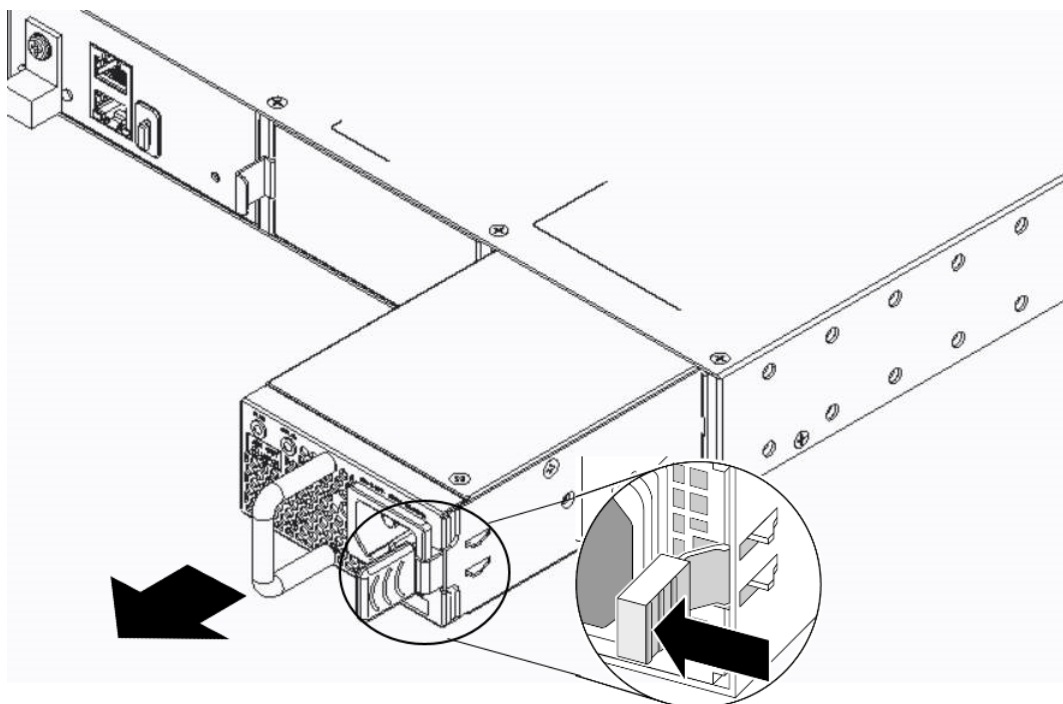

Figure 76: Removing an 1100 W AC Power Supply

4. Carefully slide the power supply the rest of the way out of the switch.



Caution

Power supplies can become very hot during operation. Wear thermal protective gloves when you remove a power supply from an operating switch.



Note

If you are not installing a replacement power supply, install a cover over the unoccupied power supply bay. Unoccupied bays must always be covered to maintain proper system ventilation and EMI levels.

5. Verify that the replacement power supply is oriented the same way as the unit you removed, and has the same airflow direction.

6. Carefully slide the power supply all the way into the power supply bay.
See [Figure 77](#).

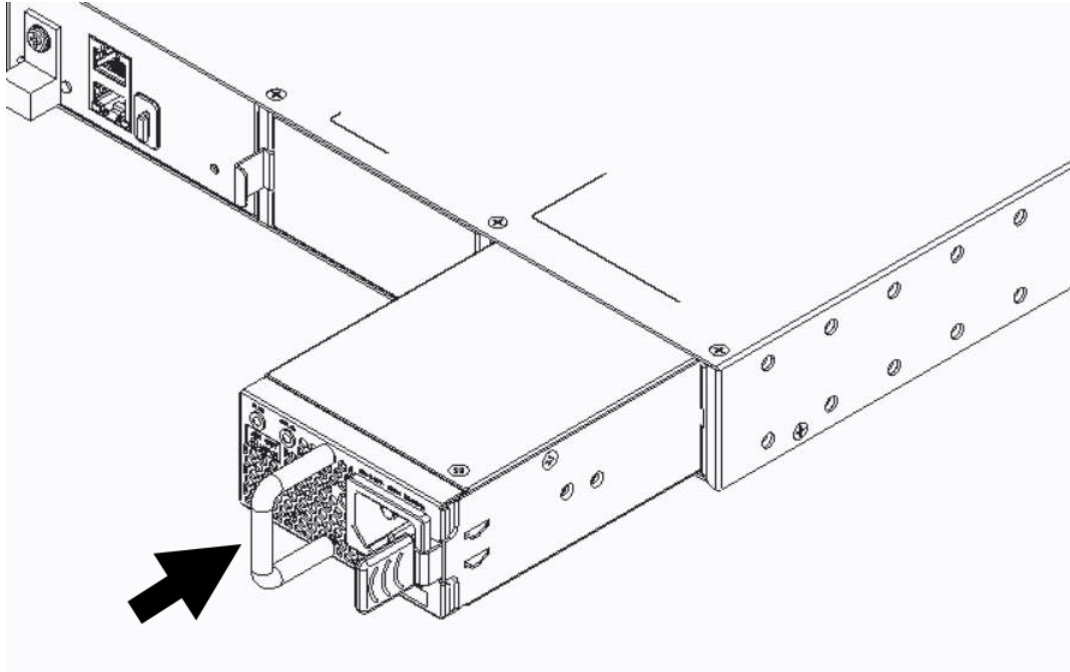

Figure 77: Installing an 1100 W AC Power Supply

7. Push the power supply in until the latch snaps into place.



Caution

Do not slam the power supply into the switch.

8. Connect the power cord to the power supply and to a grounded AC power outlet.



Warning

Always be sure that the source outlet is properly grounded before plugging the AC power cord into the AC power supply.

9. If the power supply is equipped with a power cord retainer, use the retainer to secure the power cord to the power supply.

Replace a 2000 W AC Power Supply

The ExtremeSwitching 2000 W AC power supplies with part numbers XN-ACPWR-2000W-FB or XN-ACPWR-2000W-F are compatible with 5520-24W, 5520-12MW-36W, and 5520-48W models.

These switches have two bays for hot-swappable power supplies. In a switch with a redundant power configuration, you can replace one Summit or ExtremeSwitching AC power supply without powering down the switch.

You need the following tools and materials to replace an ExtremeSwitching 2000 W AC power supply:

- Thermal protective gloves
- AC power cord, if you will not be re-using the cord from the removed power supply

To replace an ExtremeSwitching 2000 W AC power supply, follow these steps:

1. Disconnect the AC power cord from the wall outlet and from the power supply.
2. Note the orientation of the installed power supply, and the location of the latching tab at the right of the unit.
3. Push the latching tab toward the power supply handle and pull outward on the handle to disengage the power supply internal connectors.

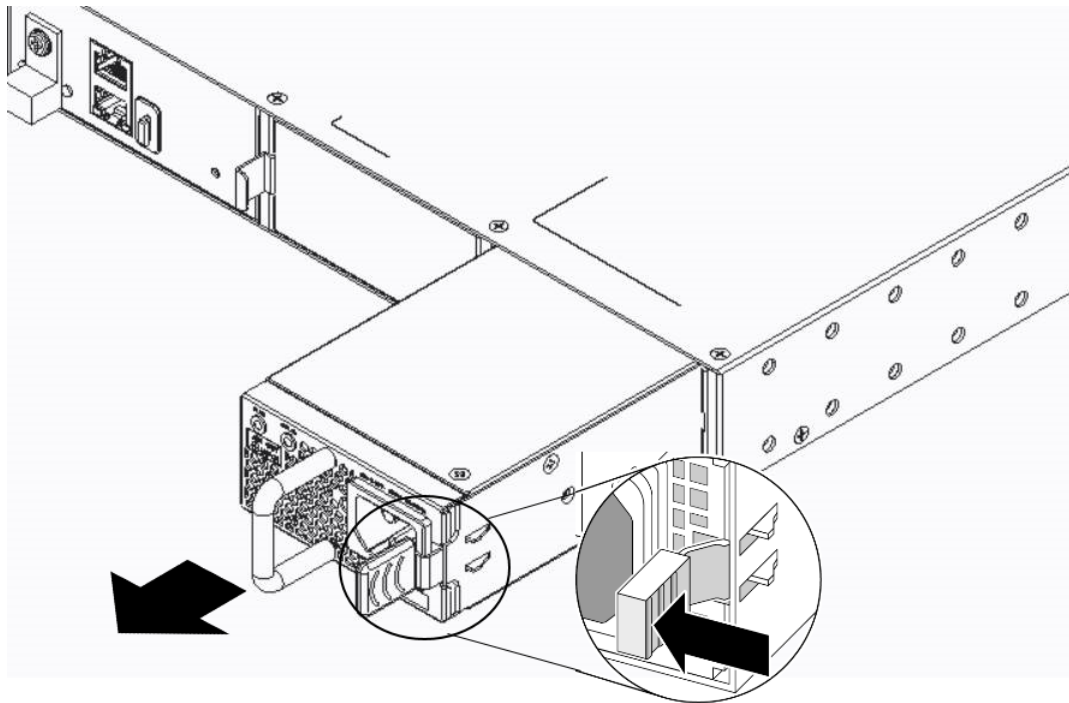

Figure 78: Removing an ExtremeSwitching 2000 W AC Power Supply

4. Carefully slide the power supply the rest of the way out of the switch.



Caution

Power supplies can become very hot during operation. Wear thermal protective gloves when you remove a power supply from an operating switch.



Note

If you are not installing a replacement power supply, install a cover over the unoccupied power supply bay. Unoccupied bays must always be covered to maintain proper system ventilation and EMI levels.

5. Verify that the replacement power supply is oriented the same way as the unit you removed, and has the same airflow direction.

- Carefully slide the power supply all the way into the power supply bay.

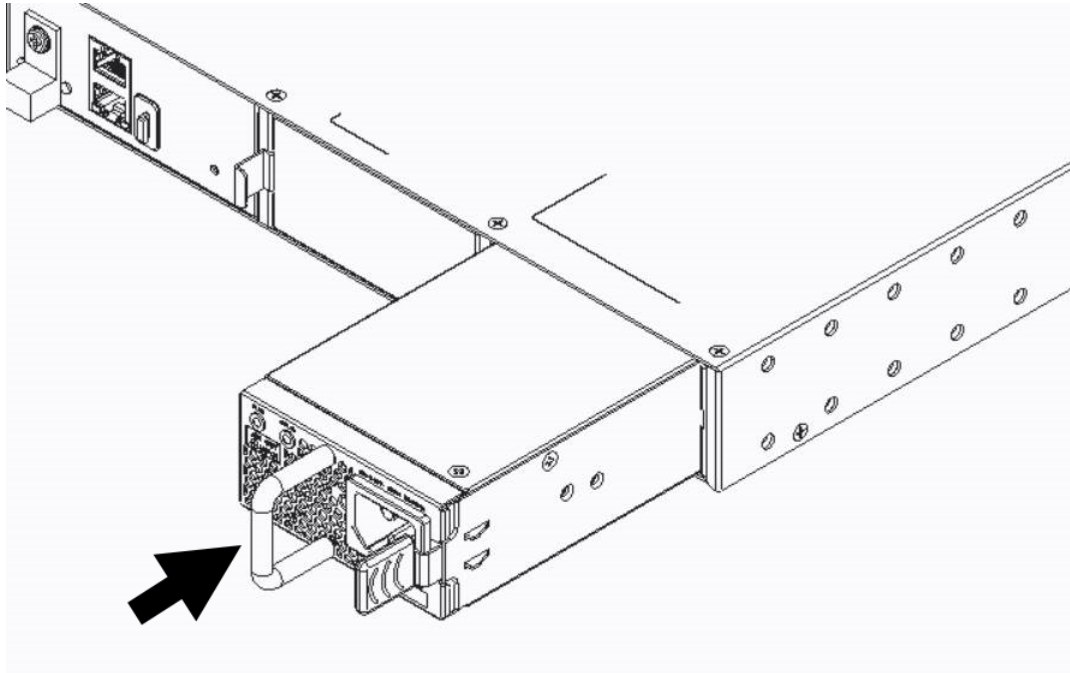

Figure 79: Installing an ExtremeSwitching 2000 W AC Power Supply

- Push the power supply in until the latch snaps into place.



Caution

Do not slam the power supply into the switch.

- Connect the power cord to the power supply and to a grounded AC power outlet.



Warning

Always be sure that the source outlet is properly grounded before plugging the AC power cord into the AC power supply.

- If the power supply is equipped with a power cord retainer, use the retainer to secure the power cord to the power supply.



Replace Fan Modules

[Pre-Installation Requirements](#) on page 121

[Airflow Direction Requirements](#) on page 121

[Replace a Fan Module](#) on page 122

For switches with replaceable fan modules, refer to the following information to replace the fan modules.



Note

Read all of the information in this chapter thoroughly before attempting to replace a fan module.

Pre-Installation Requirements

You need a 1/4-inch flat-blade screwdriver to replace a fan module.



Caution

Be sure to finish the replacement procedure promptly. The switch could overheat if left without cooling for an extended period.

Airflow Direction Requirements

Most 5520 Series switches are available with front-to-back airflow. In this switch, the fan modules are labeled **Air Out**.

Models 5520-24T-BASE, 5520-24X-BASE, 5520-48T-BASE, and 5520-48SE-BASE are available with back-to-front airflow or front-to-back airflow. In switches with back-to-front airflow, the fan modules are labeled **Air In**.

All installed fan modules must blow air in the same direction and must match the airflow direction of the installed power supplies.

The latch on the power supply is color-coded to indicate airflow direction. PSU modules with a red latch have front-to-back airflow. PSU modules with a blue latch have back-to-front airflow.

Replace a Fan Module

To replace the fan module in a switch, do the following:

1. Completely loosen the captive retaining screws on the fan module.

On most switch models, the fan module has two retaining screws at the bottom corners of the module, as shown in [Figure 80](#).

On some switch models, the fan module has a single retaining screw at the top right corner of the module.

2. Slide the fan module out of the switch and set it aside.

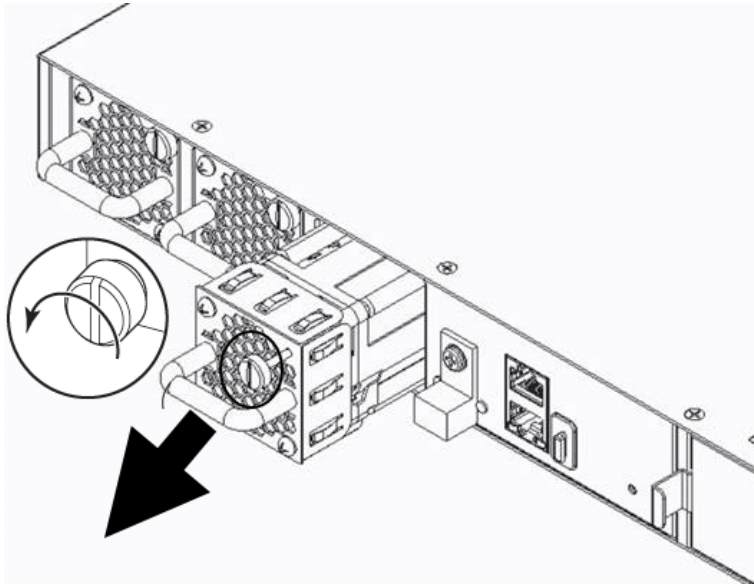

Figure 80: Removing a Fan Module

3. Verify that the airflow direction on the replacement fan module matches that of the installed fan modules.

Fans with front-to-back airflow are labeled **Air Out**. Fans with back-to-front airflow are labeled **Air In**.

- Carefully slide the replacement fan module into the switch.

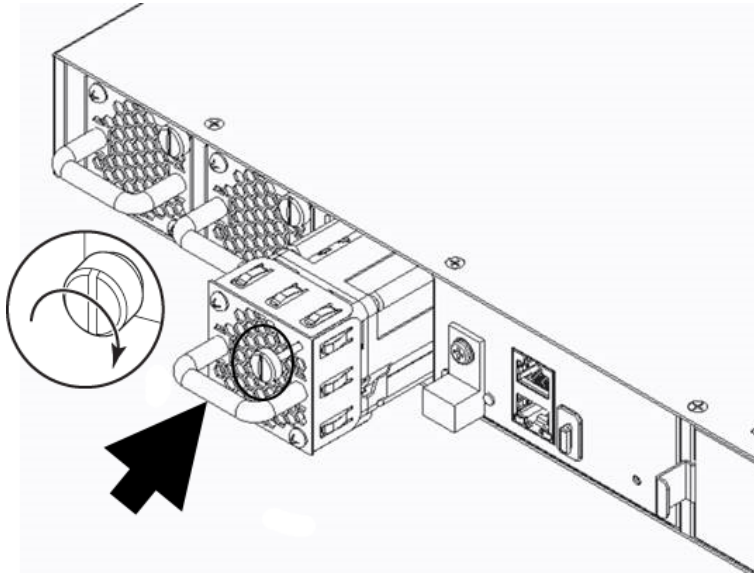

Figure 81: Installing a Fan Module

- Align and fully tighten the captive retaining screws.



Monitor the Device

[5520 Series Switch LEDs](#) on page 124

[Versatile Interface Modules \(VIM\) Port LEDs](#) on page 126

The following topics help you monitor the status of the switch/appliance as it is running.

5520 Series Switch LEDs

ExtremeSwitching 5520 Series Front Panel Port LEDs, as described in the following table:

Table 26: 5520 Series Port LEDs

LED	Color/State	Port State
SYStem status LED (Legacy MGMT function)	Green Flash slowly	POST Passed, normal operation, blinks on standalone switch, stack master, and backup nodes in a stack; off for standby nodes in a stack
	Green Blinking	POST in progress
	Amber Blinking	POST failed or overheat
PSU status LEDs P1/P2	Green	Power On
	Off	Power off and no power attached
	Amber Blinking	Power supply failures
Fan status LEDs (F1, F2 and F3)	Green	Normal operation
	Amber Blinking	Fan failure
	Amber	Fan absent
Bluetooth Status LED (BT)	Green Blinking	Bluetooth pairing in progress
	Green	Bluetooth connected
Locator LED (LOC)	Blue Blinking	Locator function

The following figure shows the two alternate mode LEDs for 5520 Series switches: SPD and STK. The Mode button is used to cycle through three display modes for the port LEDs. In the default mode, SPD and STK will be off. SPD and STK display modes will expire after 30 seconds, at which time the port LEDs will revert to the default SYS mode.

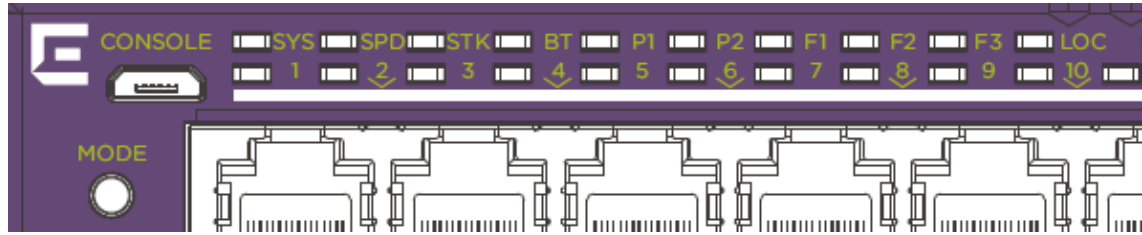

Figure 82: 5520 Series Mode and System Status LEDs



Note

Front-panel PoE ports use Amber to indicate PoE states.

Port LEDs in Default (SYS) Mode

In the default SYS mode, SPD is OFF, and the port status will display behavior for link, traffic, and PoE as described in the following table:

Table 27: Port LEDs in SYS Mode (default)

Color/State	Meaning
Steady green	Link is OK; port is not powered
Steady amber	Link is OK; port is powered; no traffic
Blinking green	Link is OK and transmitting packets; port is not powered
Blinking amber	Link is OK and transmitting packets; port is powered
Slow blinking amber	No link, or disabled port; port is powered
Alternating amber and green	Port has a power fault
Off	Port is not powered, has no link, or is disabled

Port LEDs in SPD Mode

After one press of the Mode button, the port LEDs will enter the SPD Display Mode, indicated by the SPD LED. SPD mode is used to help determine the operational speed of a port.

There are two LEDs per QSFP28 port on 5520 models. In stack mode, the first LED will represent the link state and traffic of the stack port with solid or blinking green. When a QSFP28 port is used for Ethernet and partitioned to 4x10 or 4x25, one LED will be shared for two ports. The first LED will indicate state for the first two ports and the second LED will indicate state for the second two ports. The LED is on or blinking green to indicate link and traffic when any of the 2 ports are up. It is off when both ports are down. In partitioned 2x50, each LED will represent link and traffic for one 50G port. In aggregate

1x40 mode, the first LED will indicate the port state and traffic and the second LED will be off. Color and blink pattern indicate speeds, as referenced by the following table:

Table 28: Port LEDs in SPD Mode

Color/State	Speed
Slow blinking green	10Mbps
Fast blinking green	100Mbps
Steady green	1000Mbps
Slow blinking amber	2.5Gbps
Fast blinking amber	5Gbps
Slow blinking green	10Gbps
Fast blinking green	25Gbps
Fast blinking green	40Gbps
Fast blinking green	50Gbps

Port LEDs in STK Mode

After two presses of the Mode button, the port LEDs will enter the STK Display Mode, indicated by the STK LED. STK mode is used to indicate slot presence and slot number via the first eight port LED, as referenced by the following table:

Table 29: Port LEDs in STK Mode

Color/State	Speed
Steady green	Slot corresponding to the port number of the LED is present
Blinking green	This slot has slot number corresponding to the port number of the blinking LED

Table 30: Management Port LEDs

Right side LED		State
Link	Solid Green	Link up
	Off	No link up or port disable
Left side LED		State
Act	Blinking Green	Packet transmitting or receiving
	Off	No packet transmitting or receiving

Versatile Interface Modules (VIM) Port LEDs

There are two supported modes for ExtremeSwitching 5520-VIM port LEDs:

- SYS - default, use normal port LED behavior for link, traffic, and PoE
- SPD – use the port LEDs to indicate operational speed

5520-VIM Port LEDs in Default (SYS) Mode

In the default SYS mode, SPD is OFF, and the port status will display behavior for link, traffic, and PoE as described in the following table:

Table 31: 5520-VIM Port LEDs in SYS Mode (default)

Color/State	Meaning
Steady green	Link is OK; port is not powered
Blinking green	Link is OK and transmitting packets; port is not powered
Slow blinking green	Port is admin disabled
Off	Port is not powered, has no link

5520-VIM Port LEDs in SPD Mode

SPD mode is used to help determine the operational speed of a port. Color and blink pattern indicate speeds, as referenced by the following table:

Table 32: 5520-VIM Port LEDs in SPD Mode

Color/State	Speed
Slow blinking green	10Gbps
Solid green	1Gbps
Fast blinking green	25Gbps



Technical Specifications

- [ExtremeSwitching 5520 Series Technical Specifications](#) on page 129
- [V300 Virtual Port Extender Specifications](#) on page 136
- [V400 Virtual Port Extender Technical Specifications](#) on page 139
- [Half-Duplex to Full-Duplex Converter Technical Specifications](#) on page 142
- [350 W AC Power Supplies Technical Specifications](#) on page 145
- [715 W AC Power Supplies Technical Specifications](#) on page 146
- [1100 W AC Power Supplies Technical Specifications](#) on page 146
- [2000 W AC Power Supply Technical Specifications](#) on page 148
- [Power Cord Requirements for AC-Powered Switches and AC Power Supplies](#) on page 148
- [Console Connector Pinouts](#) on page 149

This section lists technical specifications for the hardware products described in this document. The 5520 Series includes the following switches:

- 5520-24T and 5520-24T-BASE switches
- 5520-24W switch
- 5520-24X and 5520-24X-BASE switches
- 5520-12MW-36W switch
- 5520-48T and 5520-48T-BASE switches
- 5520-48W switch
- 5520-48SE and 5520-48SE-BASE switches

ExtremeSwitching 5520 Series Technical Specifications

Table 33: 5520 Unpackaged Dimensions (with fan modules; no PSU)

5520 (all models)	Height: 1.7 inches (4.35 cm) Width: 17.4 inches (44.19 cm) Length: 17.4 inches (44.19 cm)
-------------------	---

Table 34: 5520 Unpackaged Dimensions (with fan modules and PSU)

5520 (all models)	Height: 1.7 inches (4.35 cm) Width: 17.4 inches (44.19 cm) Length: 18.1 inches (45.97 cm)
-------------------	---

Table 35: 5520 Unpackaged Weight (with fan modules; no PSU)

5520-24T	12.21 lb (5.54 kg)
5520-24W	13.77 lb (6.25 kg)
5520-24X	13.77 lb (6.25 kg)
5520-12MW-36W	13.95 lb (6.33 kg)
5520-48T	12.69 lb (5.76 kg)
5520-48W	13.36 lb (6.06 kg)
5520-48SE	12.56 lb (5.70 kg)

Table 36: 5520 Unpackaged Weight (with fan modules and PSU)

5520-24T with 350W PSU and 2 fans	14.99 lb (6.8 kg)
5520-24W with 1100W PSU and 3 fans	17.37 lb (7.88 kg)
5520-24X with 350W PSU and 2 fans	16.54 lb (7.51 kg)
5520-12MW-36W with 1100W PS and 3 fans	17.54 lb (7.97 kg)
5520-48T with 350W PSU and 3 fans	15.83 lb (7.18 kg)
5520-48W with 1100W PSU and 3 fans	16.97 lb (7.7 kg)
5520-48SE with 350W PSU and 3 fans	15.69 lb (7.12 kg)

Table 37: 5520 Packaged Dimensions

5520 (all models)	Height: 6.7 inches (16.9 cm) Width: 21.6 inches (54.8 cm)
-------------------	--

Table 37: 5520 Packaged Dimensions (continued)

	Length: 23.4 inches (59.4 cm)
--	-------------------------------

Table 38: 5520 Packaged Weight (with fan modules; no PSU)

5520-24T	19.06 lb (8.65 kg)
5520-24W	20.63 lb (9.36 kg)
5520-24X	20.28 lb (9.20 kg)
5520-12MW-36W	20.81 lb (9.44 kg)
5520-48T	19.55 lb (8.87 kg)
5520-48W	20.28 lb (9.17 kg)
5520-48SE	19.42 lb (8.81 kg)

Table 39: VIM Module Unpacked Weights and Dimensions

VIM Module	Weight	Dimensions
5520-VIM-4X	0.37 lb (0.17 kg)	Height: 1.5 inches (3.83 cm) Width: 1.7 inches (4.26 cm) Length: 7.2 inches (18.2 cm)
5520-VIM-4XE	0.44 lb (0.20 kg)	
5520-VIM-4YE	0.46 lb (0.21 kg)	

Table 40: VIM Module Packed Weight and Dimensions

VIM Module	Weight	Dimensions
5520-VIM-4X	0.59 lb (0.27 kg)	Height: 1.9 inches (4.9 cm) Width: 4.2 inches (10.7 cm) Length: 8.6 inches (21.9 cm)
5520-VIM-4XE	0.64 lb (0.29 kg)	
5520-VIM-4YE	0.66 lb (0.3 kg)	

Fan and Accoustic Noise

Refer to the [5520 Data Sheet](#) for up-to-date information.

Fan Speed and Temperature Variation

The speed of the fan increases only when the temperature of the device increases. Fan speed is not dependent on any fan failures.

Table 41: 5520 Fan Speed and Power Consumption

Fan Speed	Fan Module RPM (typical)		Power	
	Inlet Fan	Outlet Fan	Typical	
Full (100%)	21000 (typ)	19000 (typ)	12V*1.7A = 20.4W per module*	
Low (20%)	4200 (typ)	3800 (typ)	2W (per module)	

* Some units are equipped with (2) fan module, while others are equipped with 3. Total fan power is equal to the number of installed fan modules multiplied by the fan power for each module.

Power Options

Refer to the [5520 Data Sheet](#) for up-to-date PoE Power Budget and Power Consumption information.

Table 42: 5520 Power Supply Options

Switch model	Power supply	Input rating
5520-24T switch 5520-24T-BASE switch 5520-24X switch 5520-24X-BASE switch 5520-48T switch 5520-48T-BASE switch	350 W AC power supply: Part nos. XN-ACPWR-350W-FB and 10953 350 W AC PS FB (front-to-back) Model PSSF351101A	100-127 V~ 200-240 V~ 50-60 Hz, 2.0/1.0 A max per PS
5520-48SE switch 5520-48SE-BASE switch	350 W AC power supply: Part nos. XN-ACPWR-350W-FB and 10953 350 W AC PS FB (front-to-back) Model PSSF351101A	100-127 V~ 200-240 V~ 50-60 Hz, 2.5/1.5 A max per PS
5520-24T-BASE switch 5520-24X-BASE switch 5520-48T-BASE switch	350 W AC power supply: Part nos. XN-ACPWR-350W-BF and DPS350AB-42 A 350 W AC PS FB (back-to-front)	100-127 V~ 200-240 V~ 50-60 Hz, 2.0/1.0 A max per PS
5520-48SE-BASE switch	Part nos. XN-ACPWR-350W-BF and DPS350AB-42 A 350 W AC PS FB (back-to-front)	100-127 V~ 200-240 V~ 50-60 Hz, 2.5/1.5 A max per PS

Table 42: 5520 Power Supply Options (continued)

Switch model	Power supply	Input rating
5520-24W switch 5520-12MW-36W switch 5520-48W switch	715 W AC power supply: Part nos. XN-ACPWR-715W-FB and 10951 715 W AC PS FB (front-to-back) Model PSSF711101A	100-127 V~ 200-240 V~ 50-60 Hz, 9/4.5 A max per PS
5520-24W switch 5520-12MW-36W switch 5520-48W switch	1100 W AC power supply: Part nos. XN-ACPWR-1100W-FB and 10941 1100 W AC PS FB (front to back) Model PSSF112101A	100-127 V~ 200-240 V~ 50-60 Hz, 12/6 A max per PS
5520-24W switch 5520-12MW-36W switch 5520-48W switch	2000 W AC power supply: Part nos. XN-ACPWR-2000W-FB and XN-ACPWR-2000W-F 2000 W AC PS FB (front to back) Model PSSF202101A	100-127 V~ 200-240 V~ 50-60 Hz, 12/10 A max per PS

**Note**

XN-ACPWR-xxx-FB PSUs cannot be used with the 10941, 10951, 10953, or XN-ACPWR-2000W-F PSUs on the same switch.

The following table lists supported PSU combinations when dual redundant PSUs are used on the switch.

Refer to the 5520 datasheet for appropriate PSUs for the switch.

Table 43: PSU Redundancy Compatibility Notes

Switch Model	Primary PSU	Secondary PSU
Non-PoE models	XN-ACPWR-350W-FB	XN-ACPWR-350W-FB
PoE models	XN-ACPWR-715W-FB or XN-ACPWR-1100W-FB or XN-ACPWR-2000W-FB	XN-ACPWR-715W-FB or XN-ACPWR-1100W-FB or XN-ACPWR-2000W-FB

Mean Time Between Failures (MTBF)

Table 44: 5520 MTBF (front-to-back airflow)

Ambient Temp = 25°C	5520-24T	5520-24W	5520-24X	5520-12M W-36W	5520-48T	5520-48W	5520-48SE
System base (all boards, modules excluded)	545,928	480,404	633,004	392,662	506,767	417,304	531,218
Complete system - A (system base+full fans+1 PSU)							
One 2000W PSU		185,080		174,532		179,138	
One 1100W PSU		212,906		199,067		205,081	
One 715W PSU		218,879		204,272		210,617	
One 350W PSU	270,711		193,198		236,070		169,687
Complete system - B (system base+ full fans+2 PSUs)							
Two 2000W PSU		123,936		119,115		121,243	
Two 1100W PSU		150,232		143,607		146,293	
Two 715W PSU		156,248		148,663		151,992	
Two 350W PSU	184,380		193,198		167,627		169,687



Note

5520-24X and 5520-24T models have 2 fan slots; All other models have 3.

Table 45: 5520 MTBF (back-to-front airflow)

Ambient Temp = 25°C	5520-48T-BASE	5520-24T-BASE	5520-24X-BASE	5520-48SE-BASE
System base	506,767	545,928	633,004	531,218

Table 45: 5520 MTBF (back-to-front airflow) (continued)

Ambient Temp = 25°C	5520-48T-BASE	5520-24T-BASE	5520-24X-BASE	5520-48SE-BASE
(without PSU and fans)				
(system base+3 fans+1 PSU)				
One 350W PSU	334,974			343,304
(system base+3 fans+2 PSUs)				
Two 350W PSU	353,898			363,209
(system base+2 fans+1 PSU)				
One 350W PSU		409,290	455,433	
(system base+2 fans+2 PSUs)				
Two 350W PSU		437,901	491,140	

CPU and Memory

Table 46: CPU, Memory

CPU/Memory
1-core, 1.7GHz x86 ARM CPU (Cortex A72)
2 GB DDR4 ECC memory
2 GB SLC NAND Flash Memory
8MB packet buffer per chip

Standards and Environmental Data

Table 47: Safety Standards

North American Safety of ITE	UL 60950-1 UL 62368-1 CAN/CSA No. 22.2 62368-1-14 CAN/CSA 22.2 No. 60950-1-07 Complies with FCC 21CFR 1040.10 (US Laser Safety) CDRH Letter of Approval (US FDA Approval)
European Safety of ITE	EN 60950-1 EN 60825-1 Class 1 (Lasers Safety) EN 62368-1 2014/32/35 EU Low Voltage Directive

Table 47: Safety Standards (continued)

International Safety of ITE	IEC 62368-1 IEC 60950-1 GB 4943.1 CNS 14336-1 CNS 15598-1 AS/NZX 60950-1 (Australia /New Zealand)
Country-specific	BSMI (Taiwan Safety) NRCS LOA (South Africa) CQC (China Safety)

Table 48: EMI/EMC Standards

North America EMC for ITE	FCC CFR 47 part 15 Class A (USA) ICES-003 Class A (Canada)
European EMC standards	EN 55032 Class A EN 55035 EN 61000-3-2 (Harmonics) EN 61000-3-3 (Flicker) ETSI EN 300 386 (EMC Telecommunications) 2014/30/EU EMC Directive EN 55011 Class A
International EMC certifications	CISPR 32, Class A (International Emissions) IEC 61000-4-2 Electrostatic Discharge, 8kV Contact, 15 kV Air, Criteria A IEC 61000-4-3-4-3 Radiated Immunity 10V/m, Criteria A IEC 61000-4-4-4-4 Transient Burst, 1 kV, Criteria A IEC 61000-4-5-4-5 Surge, 2 kV L-L, 2 kV L-G, Level 3, Criteria A IEC 61000-4-6-4-6 Conducted Immunity, 0.15-80 MHz, 10V/m unmod. RMS, Criteria A IEC 61000-4-11 Power Dips & Interruptions, >30%, 25 periods, Criteria C
Country-specific	CNS 15936, AS/NZS CISPER 32 VCCI Class A (Japan Emissions) BSMI (Taiwan Emissions) ACMA (C-Tick) (Australia Emissions) CQC Mark (China) KCC Mark, EMC Approval (Korea) Anatel (Brazil) NOM (Mexico) EAC Mark (Russia, Belarus, Kazakhstan, Kyrgyzstan, and Armenia) TEC (India)

Table 49: Telecom Standards

	EN/ETSI 300 386 EN 300 386 V2.1.1 (2016-07) (EMC Telecommunications) EN/ETSI 300 019 (Environmental for Telecommunications)
--	--

Table 49: Telecom Standards (continued)

	MEF9 and MEF14 certified for EPL, EVPL, and ELAN
--	--

Table 50: IEEE 802.3 Media Access Standards

	IEEE 802.3ab 1000BASE-T IEEE 802.3z 1000BASE-X IEEE 802.3ae 10GBASE-X IEEE 802.3ba 40GBASE-X IEEE 802.3bz 2.5GBASE-T and 5GBASE-T (for X460-G2-16mp-32p-10GE4) IEEE 802.3at PoE Plus IEEE 802.3az (EEE)
--	---

Table 51: Environmental Data

Environmental standards	EN/ETSI 300 019-2-1 v2.1.2 (2000 - 2009) - Class 1.2 Storage EN/ETSI 300 019-2-2 v2.1.2 (1999 - 09) - Class 2.3 Transportation EN/ETSI 300 019-2-3 v2.1.2 (2003 - 04) - Class 3.1e Operational EN/ETSI 300 753 (1997-10) - Acoustic Noise ASTM D3580 Random Vibration Unpackaged 1.5G
Operating conditions	Temperature range: 0°C to 50°C (32°F to 122°F) Humidity: 10% to 95% relative humidity, non-condensing Altitude: 0 to 3,000 meters (9,850 feet) Operational shock (half sine): 30 m/s ² (3 G), 11 ms, 60 shocks Operational random vibration: 3 to 500 Hz at 1.5 G rms
Storage & transportation conditions (packaged)	Transportation temperature: -40°C to 70°C (-40°F to 158°F) Storage and transportation humidity: 10% to 95% relative humidity, non-condensing Packaged shock (half sine): 180 m/s ² (18 G), 6 ms, 600 shocks Packaged sine vibration: 5 to 62 Hz at velocity 5 mm/s, 62 to 500 Hz at 0.2 G Packaged random vibration: 5 to 20 Hz at 1.0 ASD w/-3 dB/oct. from 20 to 200 Hz 14 drops minimum on sides and corners at 42 inches (<15 kg box)

V300 Virtual Port Extender Specifications

The following V300 Virtual Port Extender models are available:

- V300-8P-2X
- V300-8T-2X
- V300-8P-2T-W

- V300HT-8P-2X
- V300HT-8T-2X

Table 52: V300 Unpackaged Dimensions

V300-8P-2X V300-8T-2X V300HT-8P-2X V300HT-8T-2X	Height:1.73 in (4.4 cm) Width: 7.76 in (19.71 cm) Length: 212 in (538.48 cm)
V300-8P-2T-W	Height: 1.73 in (4.4 cm) Width: 8.26 in (21 cm) Length: 7.48 in (19 cm)

Table 53: V300 Unpackaged Weight

V300-8P-2X V300-8T-2X V300HT-8P-2X V300HT-8T-2X	3.31 lb (1.5 kg)
V300-8P-2T-W	3.22 lb (1.46 kg)

Table 54: V300 Packaged Dimensions

V300-8P-2X	Height: 3.07 in (7.79 cm) Width: 11.52 in (29.26 cm) Length: 19.98 in (50.74 cm)
V300-8T-2X	Height: 3.07 in (7.79 cm) Width: 10.15 in (25.78 cm) Length: 17.61 in (44.72 cm)
V300-8P-2T-W	Height: 3.08 in (7.82 cm) Width: 10.85 in (27.56 cm) Length: 11.52 in (29.26 cm)
V300HT-8P-2X V300HT-8T-2X	Height: 3.07 in (7.79 cm) Width: 10.15 in (25.78 cm) Length: 14.46 in (36.72 cm)

Table 55: V300 Packaged Weight

V300-8P-2X with 280W PSU	7.94 (3.6 kg)
V300-8T-2X with 40W PSU	5.73 lb (2.6 kg)
V300-8P-2T-W	4.1 lb (1.86 kg)
V300HT-8P-2X V300HT-8T-2X	3.97 (1.8kg)

Power Specifications



Note

When you use a redundant power supply (RPS), only redundant power – not additive power – is supported. Thus, the PoE ports load does not increase when an RPS is added.

Table 56: V300 Power Options

V300-8P-2X	DC Input: 54VDC, 4.5A max
V300-8T-2X	DC Input: 12VDC, 1.5A max
V300-8P-2T-W	The PoE PSE Budget is dynamically determined by the 802.3bt Type 4 PD input power applied to its uplinks as follows: <ul style="list-style-type: none"> • 2 x 90W = PoE ports load to 105W • 1 x 90W = PoE ports load to 50W • 2 x 60W = PoE ports load to 75W • 1 x 60W = PoE ports load to 30W • 2 x 30W = PoE ports load to 30W • 1 x 30W = PoE ports load to 0W
V300HT-8P-2X	DC Input: 54VDC, 4.5A max
V300HT-8T-2X	DC Input: 12VDC, 1.5A max

Table 57: Power Specifications

	Minimum ³ Heat Dissipation (BTU/hr)	Minimum ³ Power Consumption (Watts)	Maximum ³ Heat Dissipation (BTU/hr)	Maximum ³ Power Consumption (Watts)
V300-8P-2X	25.9	7.6W	118.2	214.6W
V300-8T-2X	11.6	3.3W	23.8	7.0W
V300-8P-2T-W	24.57	7.2W	82.1	129.1W
V300HT-8P-2X	25.8	7.6W	113.7	213.3W
V300HT-8T-2X	16.6	4.9W	7.4	25.2W

² Minimum is defined as idle, with no ports linked. Maximum is defined as fans high, all ports 100% traffic.

Standards and Environmental Data

Table 58: Safety Standards

North American Safety of ITE	UL 60950-1 2nd Ed., A2:2014, Listed Device (US) CSA 22.2 #60950-1-07 2nd Ed., 2014-10 Canada Complies with FCC 21CFR 1040.10 (US Laser Safety) CDRH Letter of Approval (US FDA Approval)
European Safety of ITE	EN 60950-1:2006 +A11+A1+A12+A2 EN 60825-1:2007 (Lasers Safety) IEC 60950-1:2005 2nd+A1:2009+A2:2013 2014/35/EU Low Voltage Directive
International Safety of ITE	CB Report & Certificate per IEC 60950-1:2005 2nd Ed. + National Differences AS/NZX 60950-1 (Australia /New Zealand)

Table 59: Environmental Data

Operating conditions	Temperature: 0°C to 60°C (32°F to 140°F) for V300 8P-2T-W and V300-8P/8T-2X models Temperature: -40°C to 70°C (-40°F to 158°F) for V300HT-8P/8T-2X models Storage and transportation temperature: -40°C to 70°C (-40°F to 158°F) Humidity: 5% to 95% relative humidity, non-condensing Altitude: 0 to 3,000 meters (9,850 feet)
----------------------	---

V400 Virtual Port Extender Technical Specifications

The following V400 Virtual Port Extender models are available:

- V400-24t-10GE2 (part no. 18101)
- V400-24p-10GE2 (part no. 18102)
- V400-48t-10GE4 (part no. 18103)
- V400-48p-10GE4 (part no. 18104)

Table 60: V400 Unpackaged Dimensions

V400-24t-10GE2	Height: 1.70 in (4.32 cm) Width: 9.97 in (25.3 cm) Length: 17.34 in (44.0 cm)
V400-24p-10GE2	Height: 1.70 in (4.32 cm) Width: 9.97 in (25.3 cm) Length: 17.34 in (44.0 cm)

Table 60: V400 Unpackaged Dimensions (continued)

V400-48t-10GE4	Height: 1.70 in (4.32 cm) Width: 9.97 in (25.3 cm) Length: 17.34 in (44.0 cm)
V400-48p-10GE4	Height: 1.70 in (4.32 cm) Width: 15.25 in (38.7 cm) Length: 17.34 in (44.0 cm)

Table 61: V400 Unpackaged Weight

V400-24t-10GE2	6.62 lb (3.00 kg)
V400-24p-10GE2	9.08 lb (4.12 kg)
V400-48t-10GE4	7.14 lb (3.26 kg)
V400-48p-10GE4	14.06 lb (6.38 kg)

Table 62: V400 Packaged Dimensions

V400-24t-10GE2	Height: 4.49 in (11.4 cm) Width: 14.66 in (37.2 cm) Length: 22.02 in (55.9 cm)
V400-24p-10GE2	Height: 4.49 in (11.4 cm) Width: 14.66 in (37.2 cm) Length: 22.02 in (55.9 cm)
V400-48t-10GE4	Height: 4.49 in (11.4 cm) Width: 14.66 in (37.2 cm) Length: 22.02 in (55.9 cm)
V400-48p-10GE4	Height: 4.49 in (11.4 cm) Width: 19.86 in (50.4 cm) Length: 22.02 in (55.9 cm)

Table 63: V400 Packaged Weight

V400-24t-10GE2	9.00 lb (4.08 kg)
V400-24p-10GE2	11.44 lb (5.19 kg)
V400-48t-10GE4	9.69 lb (4.39 kg)
V400-48p-10GE4	16.56 lb (7.50 kg)

Power Specifications



Note

When you use a redundant power supply (RPS), only redundant power – not additive power – is supported. Thus, the PoE ports load does not increase when an RPS is added.

Table 64: V400 Power Options

V400-24t-10GE2	AC Input: 100-240 VAC, 50/60 Hz, 0.6 A max
V400-24p-10GE2	AC Input: 100-240 VAC, 50/60 Hz, 2.2 A max DC RPS input: 54 VDC, 18.52 A max <ul style="list-style-type: none"> • PoE ports load to 382 W for AC input only. • PoE ports load to 720 W for DC input only. • PoE ports load to 720 W for AC+DC input.
V400-48t-10GE4	AC Input: 100-240 VAC, 50/60 Hz, 1.0 A max
V400-48p-10GE4	AC Input: 100-240 VAC, 50/60 Hz, 12.0 - 6.0 A max DC RPS input: 54 VDC, 18.52 A max <ul style="list-style-type: none"> • PoE ports load to 740 W for AC input only. • PoE ports load to 900 W for DC input only. • PoE ports load to 1440 W for AC+DC input.

Table 65: Power Specifications

	Minimum ³ Heat Dissipation (BTU/hr)	Minimum ³ Power Consumption (Watts)	Maximum ³ Heat Dissipation (BTU/hr)	Maximum ³ Power Consumption (Watts)
V400-24t-10GE2	36.1	10.6	75.2	22.1
V400-24p-10GE2	109.8	32.2	336.8	478.7
V400-48t-10GE4	66.0	19.3	134.8	39.5
V400-48p-10GE4	168.9	49.5	583.2	910.9
VX-RPS-1000	141.3	41.4	3152.8	924

³ Minimum is defined as idle, with no ports linked. Maximum is defined as fans high, all ports 100% traffic.

Fan and Acoustic Sound

Table 66: Fan and Acoustic Sound

	Bystander Sound Pressure ⁴ in dB(A)	Declared Sound Power (LWAd) ⁴ in bels
V400-24t-10GE2	41.6 (Duty 30%) / 59.4 (max.)	4.4 (Duty 30%) / 6.2 (max.)
V400-24p-10GE2	47.5 (Duty 30%) / 64.0 (max.)	5.0 (Duty 30%) / 6.7 (max.)
V400-48t-10GE4	43.4 (Duty 30%) / 61.1 (max.)	4.6 (Duty 30%) / 6.4 (max.)
V400-48p-10GE4	48.5 (Duty 30%) / 65.5 (max.)	5.1 (Duty 30%) / 6.8 (max.)

Standards and Environmental Data

Table 67: Safety Standards

North American Safety of ITE	UL 60950-1 2nd Ed., A2:2014, Listed Device (US) CSA 22.2 #60950-1-07 2nd Ed., 2014-10 Canada Complies with FCC 21CFR 1040.10 (US Laser Safety) CDRH Letter of Approval (US FDA Approval)
European Safety of ITE	EN 60950-1:2006 +A11+A1+A2+A2 EN 60825-1:2007 (Lasers Safety) IEC 60950-1:2005 2nd+A1:2009+A2:2013 2014/35/EU Low Voltage Directive
International Safety of ITE	CB Report & Certificate per IEC 60950-1:2005 2nd Ed. + National Differences AS/NZX 60950-1 (Australia /New Zealand)

Table 68: V400 Environmental Data

Operating conditions	Temperature: 0°C to 50°C (32°F to 122°F) for non-PoE models Temperature: 0°C to 45°C (32°F to 113°F) for PoE models Storage and transportation temperature: -40°C to 70°C (-40°F to 158°F) Humidity: 5% to 95% relative humidity, non-condensing Altitude: 0 to 3,000 meters (9,850 feet)
----------------------	---

Half-Duplex to Full-Duplex Converter Technical Specifications

The Half-Duplex to Full-Duplex Converter can be attached to switch ports to enable communication over half-duplex connections with older Ethernet devices.

⁴ At 25°C and 50% PoE load where applicable

Order the converter using one of the following part numbers:

- 10958: HDX to FDX Converter, Rest of World
- 10959: HDX to FDX Converter: North America

Other specifications:

- 8.8 Gbps switching capacity
- 4 priority queues
- 192Kb packet buffer

Table 69: Half-Duplex to Full-Duplex Converter Packaged Dimensions

Height	2.69 cm (1.06 in)
Width	12.9 cm (5.08 in)
Depth	6.91 cm (2.72 in)
Weight	200 g (0.44 lb)

Half-Duplex to Full-Duplex Converter Power Specifications

Table 70: Rest of the World External Power Pack (10958-CEE 7/1)

Voltage input range	200-240 VAC
Line frequency range	50 to 60 Hz
Operating temperature	0°C to 40°C (32°F to 104°F) normal operation

Table 71: North American External Power Pack (10959-NEMA 1-15P)

Voltage input range	100-120 VAC
Line frequency range	50 to 60 Hz
Operating temperature	0°C to 40°C (32°F to 104°F) normal operation

Half-Duplex to Full-Duplex Converter Environmental Data and Standards

Table 72: Environmental Data

Environmental conditions	<p>Operating temperature: -40°C to 70°C (-40°F to 158°F) Storage temperature: 0°C to 40°C (32°F to 104°F) Humidity: 10% to 95% relative humidity, non-condensing Altitude: 0 to 2,000 meters (6,562 feet) Packaged shock (half sine): 180 m/s² (18 G), 6 ms, 600 shocks Packaged vibration: 5 to 62 Hz at velocity 5 mm/s, 62 to 500 Hz at 0.2 G Packaged random vibration: 5 to 20 Hz at 1.0 ASD w/-3 dB/oct. from 20 to 200 Hz Packaged drop height: 14 drops minimum on sides and corners at 42 inches (<15 kg box)</p>
--------------------------	---

Table 73: Safety Standards

North American ITE	<p>UL 60950-1 2nd Ed., Listed Device (U.S.) CSA 22.2 #60950-1-03 2nd Ed. (Canada) Complies with FCC 21CFR 1040.10 (U.S. Laser Safety)</p>
European/International ITE	<p>EN 60950-1:2007 2nd Ed. CB Report & Certificate per IEC 60950-1 2nd Ed. + National Differences AS/NZS 60950-1 (Australia /New Zealand)</p>
EMI/EMC Standards	<p>FCC CFR 47 part 15 Class A (USA) ICES-003 Class A (Canada) EN 55022: Class A EN 55024:A2 Class A includes IEC 61000-4-2, 3, 4, 5, 6, 11 EN 61000-3-2,8 (Harmonics) EN 61000-3-3 (Flicker) 2014/30/EU EMC Directive</p>
International EMC Certifications	<p>CISPR 22: Ed 5.2, Class A (International Emissions) CISPR 24:A2: Class A (International Immunity) IEC 61000-4-2: EN 61000-4-2:2009 Electrostatic Discharge, 8kV Contact, 15 kV Air, Criteria A IEC 61000-4-3: EN 61000-4-3:2006+A1:2008 Radiated Immunity 10V/m, Criteria A IEC 61000-4-4: am1 ed.2./EN 61000-4-4:2004/A1:2010 Transient Burst, 1 kV, Criteria A IEC 61000-4-5: EN 61000-4-5:2006 Surge, 2 kV L-L, 2 kV L-G, Level 3, Criteria A IEC 61000-4-6: EN 61000-4-6:2009 Conducted Immunity, 0.15-80 MHz, 10V/m unmod. RMS, Criteria A IEC/EN 61000-4-11: Power Dips & Interruptions, >30%, 25 periods, Criteria C</p>
IEEE 802.3 Media Access Standards	<p>IEEE 802.3ab 1000BASE-T IEEE 802.3az EEE</p>
Environmental specifications	<p>EN/ETSI 300 019-2-1 v2.1.2 - Class 1.2 Storage EN/ETSI 300 019-2-2 v2.1.2 - Class 2.3 Transportation EN/ETSI 300 019-2-3 v2.1.2 - Class 3.1e Operational ASTM D3580 Random Vibration Unpackaged 1.5 G</p>

350 W AC Power Supplies Technical Specifications

The 350 W AC power supplies with front-to-back airflow (part nos. XN-ACPWR-350W-FB and 10953) are available for use in 5520-24T, 5520-24X, 5520-48T, and 5520-48SE model switches:

Table 74: Physical Specifications

Dimensions	Height: 1.57 inches (4.0 cm) Width: 3.25 inches (8.3 cm) Length: 10.22 inches (26.0 cm)
Weight	2.55 lb (1.12 kg)

The 350 W AC power supplies with back-to-front airflow (part nos. XN-ACPWR-350W-BF and DPS350AB-42 A) are available for use in 5520-24T-BASE, 5520-24X-BASE, 5520-48T-BASE, and 5520-48SE-BASE.

Table 75: Physical Specifications

Dimensions	Height: 1.58 inches (4.0 cm) Width: 3.25 inches (8.3 cm) Length: 10.26 inches (26.0 cm)
Weight	2.25 lb (1.02 kg)

Table 76: Power Specifications

Voltage input range	100-127/200-240~ 47 to 63Hz
Nominal input ratings	12.5 A max at 115VAC and 6A max at 230VAC at Full 350 W load
Maximum inrush current	45A at Max 264 VAC at 25C with cold start
Output	54 V, 13.2 A max, 350 W
Power supply input socket and cord	IEC/EN 60320-1/C16 AC input receptacles
Power cord wall plug	Refer to Power Cord Requirements for AC-Powered Switches and AC Power Supplies on page 148
Efficiency	Minimum efficiency: 88% at maximum power output

Table 77: Environmental Specifications

Operating temperature	-10°C to 50°C (normal operation)
Storage temperature	-40°C to 70°C
Operating humidity	93% relative humidity, non-condensing at 30C
Operational shock	30 m/s ² (3 G)

715 W AC Power Supplies Technical Specifications

The 715 W AC power supplies with front-to-back airflow (part nos. XN-ACPWR-715W-FB and 10951) are available for use in 5520-24W, 5520-12MW-36W, and 5520-48W model switches.

Table 78: Physical Specifications

Dimensions	Height: 1.57 inches (4.0 cm) Width: 3.25 inches (8.3 cm) Length: 10.22 inches (26.0 cm)
Weight	2.55 lb (1.12 kg)

Table 79: Power Specifications

Voltage input range	100-127/200-240~ 47 to 63Hz
Nominal input ratings	12.5 A max at 115VAC and 6A max at 230VAC at Full 715 W load
Maximum inrush current	45A at Max 264 VAC at 25C with cold start
Output	54 V, 13.2 A max, 715 W
Power supply input socket and cord	IEC/EN 60320-1/C16 AC input receptacles
Power cord wall plug	Refer to Power Cord Requirements for AC-Powered Switches and AC Power Supplies on page 148
Efficiency	Minimum efficiency: 88% at maximum power output

Table 80: Environmental Specifications

Operating temperature	-10°C to 50°C (normal operation)
Storage temperature	-40°C to 70°C
Operating humidity	93% relative humidity, non-condensing at 30C
Operational shock	30 m/s ² (3 G)

1100 W AC Power Supplies Technical Specifications

AC Power Supplies

The 1100 W AC power supplies with front-to-back airflow (part nos. XN-ACPWR-1100W-FB and 10941) are available for use in 5520-24W, 5520-12MW-36W, and 5520-48W model switches.

Table 81: Physical Specifications

Dimensions	Height: 1.57 inches (4.0 cm) Width: 3.25 inches (8.3 cm) Length: 10.22 inches (26.0 cm)
Weight	2.55 lb (1.12 kg)

Table 82: Power Specifications

Voltage input range	100-127/200-240~ 47 to 63Hz
Nominal input ratings	12.5 A max at 115VAC and 6 A max at 230VAC at full 1100 W load
Maximum inrush current	45A at Max 264 VAC at 25C with cold start
Output	54 V, 20 A max, 1100 W
Power supply input socket and cord	IEC/EN 60320-1/C16 AC input receptacles
Power cord wall plug	Refer to Power Cord Requirements for AC-Powered Switches and AC Power Supplies on page 148
Efficiency	Minimum efficiency: 88% at maximum power output

Table 83: Environmental Specifications

Operating temperature	0°C to 50°C (normal operation)
Storage temperature	-40°C to 70°C
Operating humidity	93% relative humidity, non-condensing at 30C
Operational shock	30 m/s ² (3 G)

2000 W AC Power Supply Technical Specifications

The 2000 W AC power supplies with front-to-back airflow (part nos. XN-ACPWR-2000W-FB and XN-ACPWR-2000W-F) are available for use in 5520-24W, 5520-12MW-36W, and 5520-48W model switches:

Table 84: Physical Specifications

Dimensions (with handle)	Height: 1.57 inches (4 cm) Width: 3.25 inches (8.25 cm) Length: 11.51 inches (29.25 cm)
Dimensions (without handle)	Height: 1.57 inches (4 cm) Width: 3.25 inches (8.25 cm) Length: 10.25 inches (26.05 cm)
Weight	2.95 lb (1.34 kg)

Table 85: Power Specifications

Voltage input range	100-240~ 50 to 60Hz
Nominal input ratings	12.5 A max at 115VAC and 6A max at 230VAC at Full 770 W load
Maximum inrush current	45A at Max 264 VAC at 25C with cold start
Output	54 V, 13.2 A max, 2000 W
Power supply input socket and cord	IEC/EN 60320-1/C16 AC input receptacles
Power cord wall plug	Refer to Power Cord Requirements for AC-Powered Switches and AC Power Supplies on page 148
Efficiency	Minimum efficiency: 88% at maximum power output

Table 86: Environmental Specifications

Operating temperature	0°C to 50°C (normal operation)
Storage temperature	-40°C to 70°C
Operating humidity	93% relative humidity, non-condensing at 30C
Operational shock	

Power Cord Requirements for AC-Powered Switches and AC Power Supplies

An AC power cord is not included with the AC power supply.

Power cords used with AC-powered switches or AC power supplies must meet the following requirements:

- The power cord must be agency-certified for the country of use.
- The power cord must have an appropriate connector for connection to the switch or power supply. See the power supply documentation for the appropriate power cord.

- The power cord must have an appropriately rated and approved wall plug applicable to the country of installation.
- For cords up to 14.76 feet (4.5m) long, the wire size must be 15 AWG (2 mm²) minimum wire length up to 4.92ft (1.5m),

For details about obtaining AC power cords for use in your country, refer to <http://www.extremenetworks.com/product/powercords/>.

Console Connector Pinouts

Table 87 describes the pinouts for a DB-9 console plug connector.

Table 87: Pinouts for the DB-9 Console Connector

Function	Pin Number	Direction
DCD (data carrier detect)	1	In
RXD (receive data)	2	In
TXD (transmit data)	3	Out
DTR (data terminal ready)	4	Out
GND (ground)	5	-
DSR (data set ready)	6	In
RTS (request to send)	7	Out
CTS (clear to send)	8	In

Figure 83 shows the pinouts for a 9-pin to 25-pin (RS-232) null-modem cable.

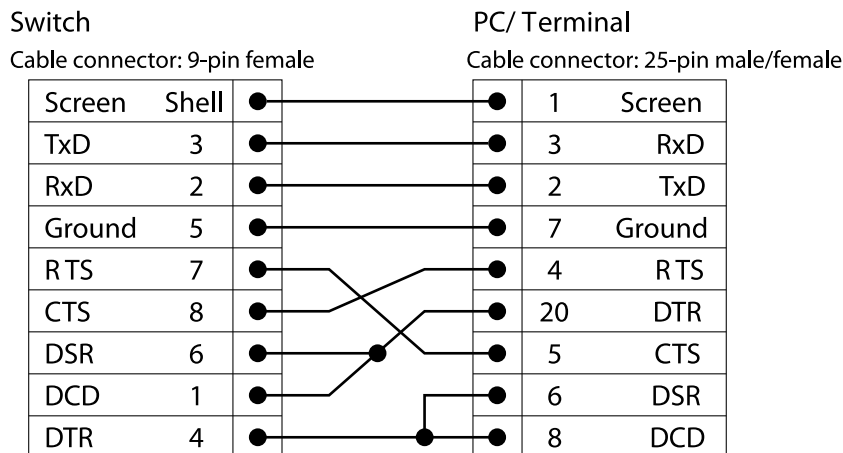

Figure 83: Null-Modem Cable Pinouts

Figure 84 shows the pinouts for a 9-pin to 9-pin (PC-AT) null-modem serial cable.

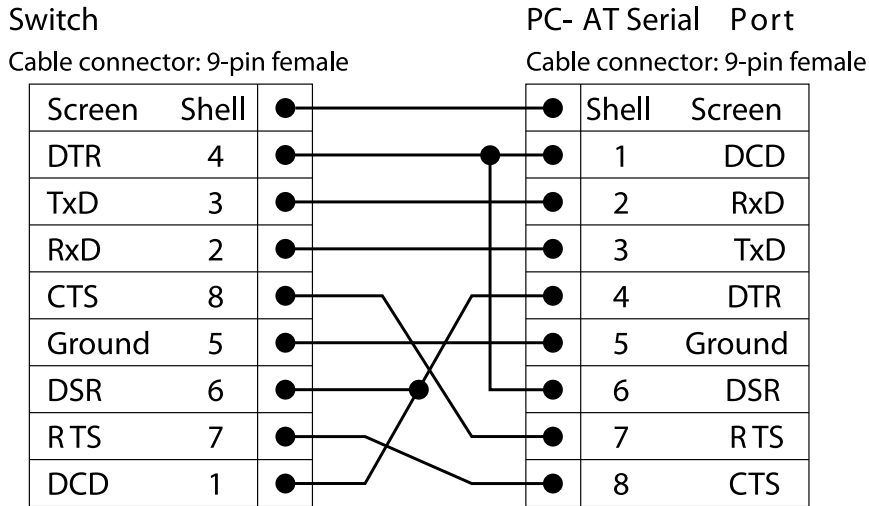

Figure 84: PC-AT Serial Null-modem Cable Pinouts

Table 88 shows the pinouts for the RJ45 console port on the ExtremeSwitching switches.

Table 88: RJ45 Console Port on Switch

Function	Pin Number	Direction
RTS (request to send)	1	Out
DTR (data carrier detect)	2	Out
TXD (transmit data)	3	Out
GND (ground)	4	—
GND (ground)	5	—
RXD (receive data)	6	In
DSR (data set ready)	7	In
CTS (clear to send)	8	In

Table 89 shows the pinouts for an RJ45-to-DB-9 adapter.

Table 89: Pinouts for an RJ45 to DB-9 Adapter

Signal	RJ45 Pin	DB-9 Pin
CTS (clear to send)	1	8
DTR (data carrier detect)	2	6
TXD (transmit data)	3	2
GND (ground)	4	5
GND (ground)	5	5
RXD (receive data)	6	3

Table 89: Pinouts for an RJ45 to DB-9 Adapter (continued)

Signal	RJ45 Pin	DB-9 Pin
DSR (data set ready)	7	4
RTS (request to send)	8	7



Safety and Regulatory Information

[Considerations Before Installing](#) on page 153

[General Safety Precautions](#) on page 153

[Maintenance Safety](#) on page 154

[Fiber Optic Ports and Optical Safety](#) on page 154

[Cable Routing for LAN Systems](#) on page 155

[Installing Power Supply Units and Connecting Power](#) on page 156

[Selecting Power Supply Cords](#) on page 157

[Battery Notice](#) on page 157

[Battery Warning - Taiwan](#) on page 158

[EMC Warnings](#) on page 158

[Japan \(VCCI Class A\)](#) on page 159

[Korea EMC Statement](#) on page 159



Warning

Read the following safety information thoroughly before installing Extreme Networks products. Failure to follow this safety information can lead to personal injury or damage to the equipment.

Only trained and qualified service personnel (as defined in IEC 60950-1 and AS/NZS 3260) should install, replace, or perform service to Extreme Networks switches and their components. Qualified personnel have read all related installation manuals, have the technical training and experience necessary to be aware of the hazards to which they are exposed in performing a task, and are aware of measures to minimize the danger to themselves or other persons.

If you are located in the United States, install the system in accordance with the U.S. National Electrical Code (NEC).

Considerations Before Installing

Consider the following items before you install equipment.

- For equipment designed to operate in a typical Telco environment that is environmentally controlled, choose a site that has the following characteristics:
 - Temperature-controlled and humidity-controlled, such that the maximum ambient room temperature shall not exceed what the equipment manufacturer recommends.
 - Clean and free from airborne materials that can conduct electricity.
 - Well ventilated and away from sources of heat including direct sunlight.
 - Away from sources of vibration or physical shock.
 - Isolated from strong electromagnetic fields produced by electrical devices.
- For equipment designed to be installed in environments that are not environmentally controlled, such as outdoor enclosures, see the product data sheet or for environmental conditions, temperature, and humidity.
- Establish at least 3 inches clearance on all sides for effective ventilation. Do not obstruct the air intake vent on the front, side, or rear ventilation grills. Locate the system away from heat sources.
- Make sure that your equipment is placed in an area that accommodates the power consumption and component heat dissipation specifications.
- Make sure that your power supplies meet the site DC power or AC power requirements of all the network equipment.
- Racks for Extreme Networks equipment must be permanently attached to the floor. Failure to stabilize the rack can cause the rack to tip over when the equipment is removed for servicing.
- Do not operate the system unless all modules, faceplates, front covers, and rear covers are in place. Blank faceplates and cover panels are required for the following functions:
 - Preventing exposure to hazardous voltages and currents inside the equipment
 - Containing electromagnetic interference (EMI) that might disrupt other equipment
 - Directing the flow of cooling air through the equipment
- Ultimate disposal of this product should be handled according to all national laws and regulations.

General Safety Precautions

Follow these guidelines:

- Do not try to lift objects that you think are too heavy for you.
- When you install equipment in a rack, load heavier devices in the lower half of the rack first to avoid making the rack top-heavy.
- Use only tools and equipment that are in perfect condition. Do not use equipment with visible damage.
- Route cables in a manner that prevents possible damage to the cables and avoids causing accidents, such as tripping.

- Do not place a monitor or other objects on top of the equipment. The chassis cover is not designed to support weight.
- To reduce the risk of fire, use only #26 AWG or larger telecommunications line cord. Use only copper conductors.
- Do not work on the system or connect or disconnect cables during periods of lightning activity.
- This equipment must be grounded. Never defeat the ground conductor or operate the equipment in the absence of a suitably installed ground conductor.

Maintenance Safety

When you perform maintenance procedures on Extreme Networks equipment, follow these recommendations:

- Use only authorized accessories or components approved for use with this system. Failure to follow these instructions may damage the equipment or violate required safety and EMC regulations.
- This system contains no customer serviceable components. Do not attempt to repair a chassis, power supply, module, or other component. In the event of failure, return the defective unit to Extreme Networks for repair or replacement, unless otherwise instructed by an Extreme Networks representative.
- To remove power from the system, you must unplug all power cords from wall outlets. The power cord is the disconnect device to the main power source.
- Disconnect all power cords before working near power supplies, unless otherwise instructed by a product-specific maintenance procedure.
- Replace a power cord immediately if it shows any signs of damage.
- When you work with optical devices, power supplies, or other modular accessories, put on an ESD-preventive wrist strap to reduce the risk of electronic damage to the equipment. Connect the other end of the strap to an appropriate grounding point on the equipment rack or to an ESD jack on the chassis if one is provided. Leave the ESD-preventive wrist strap permanently attached to the equipment rack or chassis so that it is always available when you need to handle components that are sensitive to ESD.
- Install all cables in a manner that avoids strain. Use tie wraps or other strain relief devices.

Fiber Optic Ports and Optical Safety

The following safety warnings apply to all optical devices used in Extreme Networks equipment that are removable or directly installed in an I/O module or chassis system.

Such devices include but are not limited to gigabit interface converters (GBICs), small form factor pluggable (SFP) modules (or mini-GBICs), QSFP+ modules, XENPAK transceivers, and XFP laser optic modules.



Warning

Laser optic modules become very hot after prolonged use. Take care when removing a laser optic module from the module or option card. If the laser optic module is too hot to touch, disengage the laser optic module and allow it to cool before removing it completely.

When working with laser optic modules, always take the precautions listed below to avoid exposure to hazardous radiation.

- Never look at the transmit LED/laser through a magnifying device while the transmit LED is powered on.
- Never look directly at a fiber port on the switch or at the ends of a fiber cable when they are powered on.
- Invisible laser radiation can occur when the connectors are open. Avoid direct eye exposure to the beam when optical connections are unplugged.
- Never alter, modify, or change an optical device in any way other than suggested in this document.

GBIC, SFP (Mini-GBIC), QSFP+, XENPAK, and XFP Regulatory Compliance

Extreme Networks pluggable optical modules and direct-attach cables meet the following regulatory requirements:

- Class 1 or Class 1M Laser Product
- EN60825-1:2007 2nd Ed. or later, European standard
- FCC 21 CFR Chapter 1, Subchapter J in accordance with FDA & CDRH requirements
- Application of CE Mark in accordance with 2014/30/EU EMC Directive and the 2014/35/EU Low Voltage Directives
- UL and/or CSA registered component for North America
- 47 CFR Part 15, Class A when installed into Extreme products

Cable Routing for LAN Systems

Extreme Networks equipment meets the requirements for LAN system equipment.

LAN systems are designed for intra-building installations; that is, cable runs between devices must be in the same building as the connected units, except under the conditions listed in the next paragraph.

As allowed in the USA by the National Electrical Code (NEC), this equipment can be connected between buildings if any one of the following conditions is true:

- Cable runs between buildings are less than 140 feet long.
- Cable runs between buildings are directly buried.

- Cable runs between buildings are in an underground conduit, where a continuous metallic cable shield or a continuous metallic conduit containing the cable is bonded to each building grounding electrode system.

**Caution**

Failure to follow these requirements for cable routing conditions may expose the user to electrical shock and expose the unit to damage that can cause errors.

**Warning**

The Ethernet ports of the equipment and its sub-assemblies are suitable only for intra-building connections (within the same building) or for connections to unexposed wiring or cabling. (See the conditions listed above.) The Ethernet ports of this equipment or its sub-assemblies must not be metalically connected to interfaces that connect to the outside plant (OSP) or its wiring. Ethernet interfaces are designed for use only as intra-building interfaces (described as Type 2 or Type 4 ports in GR-1089-CORE, Issue 6) and require isolation from the exposed OSP wiring. The addition of Primary Protectors is not sufficient protection to connect these interfaces metalically to OSP wiring. This warning does not apply to T1/E1 ports because T1/E1 ports have built-in isolation and surge protection that allows them to be connected to OSP wiring.

Installing Power Supply Units and Connecting Power

For the ratings and power input requirements of each power supply unit, see "Technical Specifications" or the data sheet for the power supply at www.extremenetworks.com.

**Warning**

Be sure to satisfy the requirements listed in this section when you install Extreme Networks power supplies or connect power.

When you install any power supply:

- Do not use excessive force when you insert a power supply into the bay.
- Do not attempt to open the power supply enclosure for any reason; the power supply does not contain user-serviceable parts. In the event of failure, return the defective power supply to Extreme Networks for repair or replacement.
- Do not put your hand into an open power supply bay when a power supply is not present.
- Before you work on equipment that is connected to power lines, remove all jewelry, including watches. Metal objects heat up when they are connected to power and ground and can cause serious burns or weld the metal object to the terminals.
- An electrical arc can occur when you connect or disconnect the power with power applied. This could cause an explosion in hazardous area installations. Be sure that power is removed from the device.
- When you install or replace equipment, always make the ground connection first and disconnect the ground connection last.

When you install DC power supplies or connect DC power:

- Extreme Networks DC power supplies do not have switches for turning the unit on and off. Make sure that the DC circuit is de-energized before connecting or disconnecting the DC power cord at the DC input power socket.
- Connect the system or power supply only to a DC power source that complies with the safety extra-low voltage (SELV) requirements in IEC 60950-based safety standards.

**Note**

Because building codes vary worldwide, consult an electrical contractor to ensure proper equipment grounding and power distribution for your specific installation and country.

**Warning**

Extreme Networks power supplies do not have switches for turning the unit on and off. Disconnect all power cords to remove power from the device. Make sure that these connections are easily accessible.

Extreme Networks alimentations n'ont pas de contact pour mettre l'appareil sous et hors tension. Débranchez tous les cordons d'alimentation pour couper l'alimentation de l'appareil. Assurez-vous que ces connexions sont facilement accessibles.

Selecting Power Supply Cords

You can purchase a power cord for your product and for your specific country from your local Extreme Networks Channel Account Manager or Sales Manager, or you can purchase a cord from your local supplier. Requirements for the power cord are listed in the Technical Specifications for your product.

To locate a Sales Manager or Partner in your region, visit www.extremenetworks.com/partners/where-to-buy.

**Note**

This equipment is not intended to be directly powered by power distribution systems where phase-phase voltages exceed 240 VAC (2P+PE), such as those used in Norway, France, and other countries. For these applications, use a transformer to step down the voltage to < 240 VAC from phase-phase, or make a connection to a (P+N+PE) power distribution where voltages do not exceed 240 VAC.

All installations should confirm that the product is reliably grounded according to the country's local electrical codes.

Battery Notice



Warning: This product contains a battery used to maintain product information. If the battery should need replacement it must be replaced by Service Personnel. Please contact Technical Support for assistance.

Risk of explosion if battery is replaced by an incorrect type. Dispose of expended battery in accordance with local disposal regulations.



Attention: Ce produit renferme une pile servant à conserver les renseignements sur le produit. Le cas échéant, faites remplacer la pile par le personnel du service de réparation. Veuillez communiquer avec l'assistance technique pour du soutien.

Il y a risque d'explosion si la pile est remplacée par un type de pile incorrect. Éliminez les piles usées en conformité aux règlements locaux d'élimination des piles.

Battery Warning - Taiwan

警告

如果更換不正確之電池型式會有爆炸的風險，
請依製造商說明書處理用過之電池。

EMC Warnings

Taiwan BSMI Warning

警告使用者:

此為甲類資訊技術設備，於居住環境中使用時，可能會造成射頻擾動，在此種情況下，使用者會被要求採取某些適當的對策。

China CQC Warning

警告使用者:

此為A級產品，在生活環境中，該產品可能會造成無線電干擾。
在這種情況下，可能需要用戶對干擾採取切实可行的措施。

Japan (VCCI Class A)

**Warning**

This is a Class A product based on the standard of the VCCI Council. If this equipment is used in a domestic environment, radio interference may occur, in which case the user may be required to take corrective actions.

この装置は、クラスA情報技術装置です。この装置を家庭環境で使用すると電波妨害を引き起こすことがあります。この場合には使用者が適切な対策を講ずるよう要求されることがあります。

VCCI-A

Korea EMC Statement

이 기기는 업무용 환경에서 사용할 목적으로 적합성평가를 받은 기기로서 가정용 환경에서 사용하는 경우 전파간섭의 우려가 있습니다.



Glossary



Index

Numerics

- 1100 W AC power supply
 - features 27
 - replacing 116
- 2000 W AC power supply
 - features 28
 - replacing 118
- 3-slot modular shelf
 - and Half-Duplex to Full-Duplex Converter 110
- 350 W AC power supply
 - features 26
 - specifications 145
- 5520 series switches
 - 715 W AC power supply 114
 - acoustic noise 130
 - fan speed 130
 - features 12–15
 - power specifications 131
 - power supply unit (PSU) 131
 - specifications 129–131, 133, 134
- 5520 Series switches
 - features 15
 - LEDs 124–126
- 5520-VIM-4X
 - module
 - features 38
- 5520-VIM-4XE
 - module
 - features 38
- 5520-VIM-4YE
 - module
 - features 39
- 715 W AC power supply
 - features 27
 - replacing 114
 - specifications 146
- 715 W DC power supply
 - features 27

A

- AC power
 - connecting to switch 81
 - requirements for cords 148
- access 43
- acoustic noise
 - 5520 switch 130
 - V400 Virtual Port Extender 141
- acquired node

- acquired node (*continued*)
 - definition 66
- active node 65
- active topology 65
- airflow 121
- alternate stacking 65
- amperage
 - calculating for UPS 56
- ANSI standards 56

B

- back-to-front cooling 121
- backup node
 - definition 66
 - redundancy 60
- battery notice 157, 158
- bend radius 48, 49
- BICSI 47
- building codes 42
- Building Industry Consulting Service International,
see BICSI

C

- cabinet
 - attaching switch 78
- cable
 - ANSI standards 56
 - bend radius 49
 - bundling 48
 - category 5 48
 - fiber optic 49, 81
 - for stacking 70
 - for switch ports 81
 - installing 48, 49
 - labeling 48
 - network interface 81
 - optical 80
 - plenum-rated 48
 - RJ45 53
 - slack 48
 - standards 47
 - types and distances 50
- candidate node 66
- category 5 cable 48
- combining
 - switches in a stack 70
- commercial building standards 56

- components
 - optional 80
- configuration
 - IP address 85
 - VLAN 85
- configuring the switch 86
- connecting
 - to management console 83
- connecting power 81
- connector jackets
 - RJ45 53
- connector pinouts
 - DB-9 console connector 149
 - null-modem cable 149
- console port
 - 5520 series 12–15
 - for stacked configurations 75
 - on switch 149
 - settings 83
- control path 65
- conventions
 - notice icons vii
 - text vii
- cooling 121
- cords
 - requirements 148
 - selecting 157

D

- daisy chain topology 63
- data port 66
- DB-9 console connector pinouts 149
- DB-9 pinouts 149
- DC power
 - connecting to switch 81
- DC-I battery return configuration 56
- design standards 56
- distances
 - cables 50
- documentation
 - feedback ix
 - location xi
- dual primary condition 63

E

- Easy-Setup 67
- election
 - node role 67
 - priority 67
- electric power
 - connecting to switch 81
- electrical codes 42
- electrostatic discharge, *see* ESD
- environmental requirements
 - building codes 42
 - electrical codes 42
 - electrostatic discharge (ESD) 45

- environmental requirements (*continued*)
 - humidity 45
 - temperature 44
 - wiring closet 43
- equipment
 - installing 76
 - tools needed to install 77
- equipment rack
 - grounding 46
 - mechanical recommendations 46
 - mounting holes 46
 - securing 47
 - service access 46
 - space requirements 46
- ESD
 - discharge from cable 48
 - system protection 45
- Extreme Stacking Tool 70

F

- Fabric Engine
 - initial login 86
- failover 67
- fan
 - airflow 121
 - replacing 121, 122
- fan speed
 - 5520 switch 130
- feedback ix
- fiber optic cable
 - bend radius 49
 - connecting 81
 - handling 49
 - installing 49
- first switch login 83, 86
- frequency, *see* radio frequency interference (RFI)
- front-to-back cooling 121

G

- grounding
 - racks 46
 - requirements 56
 - wiring closet 43

H

- Half-Duplex to Full-Duplex Converter
 - connecting to power 111
 - installing 110, 111
 - mounting in a rack 110
 - mounting on a flat surface 110
 - mounting on a shelf 110
 - mounting on a wall 111
 - specifications 142–144
- hitless failover 67
- humidity 45

I

- industry standards 56
- initial switch login 83, 86
- installing
 - connecting power 81
 - fiber optic cable 49
 - Half-Duplex to Full-Duplex Converter 110, 111
 - optical transceivers 80
 - optional components 80
 - personnel 77
 - preparing 77
 - safety information 77
 - switches 76–78
 - tools 77
 - V300 Virtual Port Extender 88, 89, 92, 94, 96, 99, 102, 105, 106
 - V400 Virtual Port Extender 109
 - VIM module 112
- IP settings
 - configuring 85

J

- jackets
 - RJ45 connector 53

L

- labeling cables 48
- LEDs
 - 5520 Series 124–126
 - 5520-VIM 126, 127
 - stack number indicator 59
- local management connection 83
- logging in to the switch 83, 86

M

- MAC address 67
- management port
 - 5520 series 12–15
 - connecting to switch 83
 - for stacked configurations 75
 - settings 83
- multiple-rack stacking 74

N

- native stacking 64
- native stacking ports 59
- network interface connections 81
- node address 67
- node role
 - definition 66
 - election 67
- notices vii
- null-modem cable pinouts 149

O

- operating environment requirements 44
- operational node 67
- optical cables
 - installing 80
- optical transceivers
 - installing 80
- optional components
 - installing 80

P

- partitioning
 - of ports 24
- pinouts
 - DB-9 console connector 149
 - null-modem cable 149
- planning
 - site 41
- plenum-rated cable 48
- pluggable transceivers, *see* optical transceivers
- port option cards
 - types 29
- ports
 - console port settings 83
 - for stacked configurations 75
 - management 83
 - native stacking 59
 - partitioning 24
- power
 - connecting to switch 81
 - requirements for cords 148
- power cords
 - selecting 54, 157
- power over Ethernet (PoE)
 - power requirements 54
- power requirements
 - PoE devices 54
 - power supply 54
- power specifications
 - 5520 switch 131
 - V300 Virtual Port Extender 137, 138
 - V400 Virtual Port Extender 140, 141
- power supply unit (PSU)
 - 1100 W AC 27
 - 2000 W AC 28, 148
 - 350 W AC 26, 145
 - 715 W AC 27, 146
 - for 5520 switches 131
 - power requirements 54
- primary node
 - definition 66
 - redundancy 60
- primary switch 68
- priority
 - for node role election 67

Q

- QSFP+ ports
 - partitioning 24
- QSFP28 ports
 - partitioning 24

R

- rack
 - attaching switch 78
 - rack specifications
 - grounding 46
 - securing to floor 47
 - space requirements 46
 - radio frequency interference (RFI)
 - patch panel installation 48
 - preventing 53
 - redundancy
 - in a stack 60
 - regulatory information 152
 - removing
 - 1100 W AC power supply 116
 - 2000 W AC power supply 118
 - 715 W AC power supply 114
 - fan module 122
 - replacing
 - 1100 W AC power supply 116
 - 2000 W AC power supply 118
 - 715 W AC power supply 114
 - fan module 122
 - restricted 43
 - restricted access 43
 - RFI, *see* radio frequency interference (RFI)
 - ring topology 62
 - RJ45 cable 53
- ## S
- safety
 - precautions when installing 77
 - requirements 152
 - service access to the rack 46
 - settings
 - for management console 83
 - signal quality 53
 - single-rack stacking 73
 - site planning 41
 - site preparation 77
 - slack in cable 48
 - slot number 59
 - space requirements, rack 46
 - specifications
 - 350 W AC power supply 145
 - 5520 switch 129–131, 133, 134
 - 715 W AC power supply 146
 - equipment racks 46
 - Half-Duplex to Full-Duplex Converter 142–144
 - V300 virtual port extender 136, 138, 139

- specifications (*continued*)
 - V400 virtual port extender 139, 141, 142
- stack 64
 - see also* SummitStack
- stack number indicator 59
- stackable switch 64
- stacking
 - backup 60
 - cables 70
 - combining switch models 70
 - connecting cables 75
 - connecting management port 75
 - connection order 72
 - daisy chain 63
 - definition 59
 - dual primary condition 63
 - examples 73, 74
 - guidelines 68, 69
 - LEDs 59
 - multiple-rack 74
 - native stacking ports 59
 - primary 60
 - priority 60
 - recommendations 68, 69
 - redundancy 60
 - ring topology 62
 - single-rack 73
 - slot number 59
 - stack number indicator 59
 - terminology 64
 - tool 70
 - troubleshooting 59
 - web app 70
- stacking link 65
- stacking port 64
- standards
 - cabling 47, 56
 - commercial building 56
 - design 56
 - grounding 56
- standby node
 - definition 66
- SummitStack
 - path 65
 - segment 67
 - state 67
 - topology 61, 65
 - web app 70
- SummitStack configuration 58
- support, *see* technical support
- switches
 - attaching to cabinet 78
 - attaching to rack 78
 - connecting power 81
 - initial login 83, 86
 - installing 76
 - installing optional components 80
 - safety information 77

switches (*continued*)
tools needed to install 77

T

technical support
contacting x
temperature 44
tools for installing equipment
switches 77
transceivers, *see* optical transceivers
transition time
UPS 56
troubleshooting stack connections 59

U

unshielded twisted pair, *see* UTP cable
UPS (uninterruptible power supply)
requirements 55
selecting 55, 56
transition time 56
UTP cable
bend radius 48
category 5 48
discharge ESD 48
preventing RFI 53

V

V300 virtual port extender
specifications 136, 138, 139
V300 Virtual Port Extender
DIN rail mounting in a rack 102
environmental data 138
installing 88, 89, 92, 94, 96, 99, 102, 105, 106
mounting in a rack 88, 89, 94, 96, 99, 105, 106
power specifications 137, 138
table 92
V300 virtual port extender LEDs 35
V300-8P-2T-W 32
V300-8T-2X 31
V400 virtual port extender
specifications 139, 141, 142
V400 Virtual Port Extender
acoustic noise 141
environmental data 142
installing 109
mounting in a rack 109
power specifications 140, 141
versatile interface module (VIM)
5520-VIM-4X 38
5520-VIM-4XE 38
5520-VIM-4YE 39
installing 112
types 29
virtual port extender 30–33, 35
VLAN
configuring 85

W

warnings vii
web app
SummitStack 70
wiring closet
electrostatic discharge (ESD) 45
floor coverings 43
grounding 43
humidity 45
rack, securing 47
temperature 44
wiring terminals 46

X

X465 series switches
2000 W AC power supply 148