

Installation Guide

NETGEAR 5-Port and 8-Port Gigabit Ethernet Smart Managed Plus SOHO Switch Model GS305E and GS308E

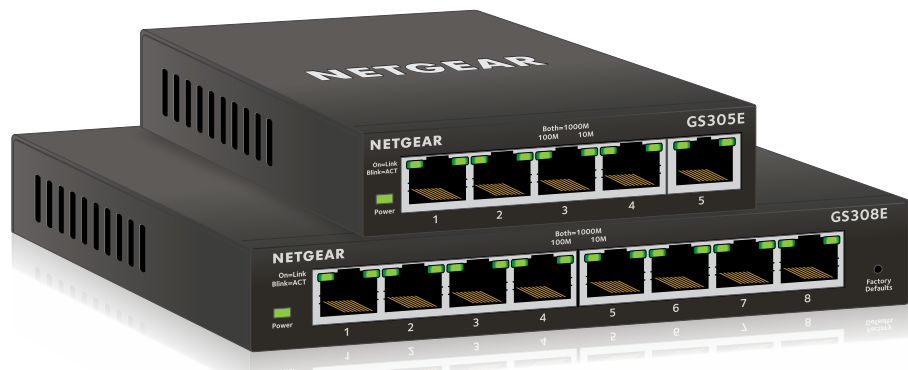

Package contents

- Switch model GS305E or GS308E
- Power adapter (varies by region)
- Installation guide

Ethernet cables not included.

July 2024



201-24520-02

1. Register with the NETGEAR Insight App

Use the NETGEAR Insight app to register your switch, activate your warranty, and access support.

1. On your iOS or Android mobile device, visit the app store, search for NETGEAR Insight, and download the latest version of the app.



2. Open the NETGEAR Insight app.
3. If you did not set up a NETGEAR account, tap **Create NETGEAR Account** and follow the onscreen instructions.
4. Enter the email address and password for your account and tap **LOG IN**.
5. Tap **+** in the upper-right corner.
6. Either use the camera on your phone to scan the serial number bar code located on the bottom of the switch, or enter the serial number.
7. Tap **Go**.
8. Follow the onscreen instructions to add your switch to a network location.
The switch is registered and added to your account.

2. Connect the Switch

Sample Network Configuration

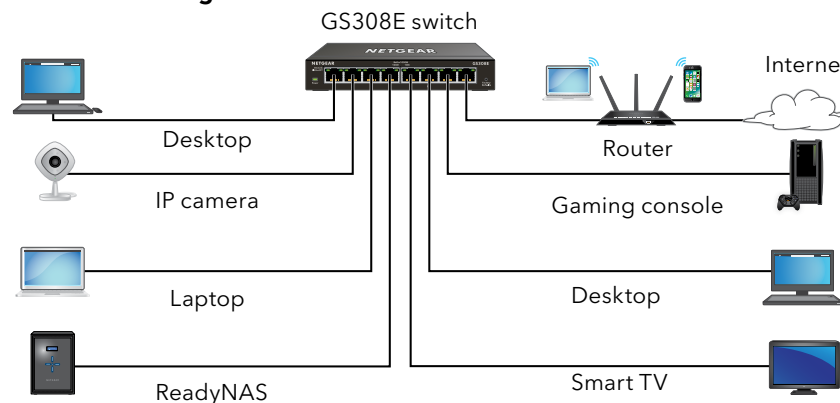

3. Discover the IP Address of the Switch

An IP address is required to configure your switch. The switch gets an IP address from a DHCP server (such as your router) by default. If your switch is not connected to a DHCP server, use the default IP address: 192.168.0.239.

1. Connect your mobile device to the same WiFi network as the switch.
2. Make sure that the network connects to the Internet.
3. Launch the NETGEAR Insight app from your mobile device.
4. Log in to your account.
The current IP address of the switch displays.

4. Configure the Switch

We recommend that you use a web browser on a computer or tablet to configure the switch.

NOTE: If your computer is a Mac, use the NETGEAR Switch Discovery Tool, as described on the other side of this document.

1. Open a web browser from a computer or tablet connected to the same network as your switch.
You can use a WiFi or wired connection.
2. Enter the IP address of the switch.
3. Enter the password.
The default password is **password**. We recommend that you change the password to a more secure password.
4. Click the **Login** button.

Other Discovery and Configuration Methods

The NETGEAR Discovery Tool also lets you discover the IP address and configure the switch.

- **NETGEAR Discovery Tool.** You can use a Mac or a 64-bit Windows-based computer that is on the same network as the switch. You can use a WiFi or wired connection. When you discover the switch, this tool provides access to the local browser interface to configure the switch. To download the NETGEAR Discovery Tool, visit <https://www.netgear.com/support/product/netgear-discovery-tool>.

If you cannot discover or configure the switch, you might need to temporarily disable the firewall, Internet security, or antivirus programs. Make sure to reenable these security services after you discover and configure the switch.

Support

Thank you for purchasing this NETGEAR product. You can visit <https://www.netgear.com/support/> to register your product, get help, access the latest downloads and user manuals, and join our community. We recommend that you use only official NETGEAR support resources.

Si ce produit est vendu au Canada, vous pouvez accéder à ce document en français canadien à <https://www.netgear.com/support/download/>. (If this product is sold in Canada, you can access this document in Canadian French at <https://www.netgear.com/support/download/>.)

For regulatory compliance information including the EU Declaration of Conformity, visit <https://www.netgear.com/about/regulatory/>.

See the regulatory compliance document before connecting the power supply.

Do not use this device outdoors. If you connect cables or devices that are outdoors to this device, see <https://kb.netgear.com/000057103> for safety and warranty information.

NETGEAR, Inc.
350 East Plumeria Drive
San Jose, CA 95134, USA

NETGEAR INTERNATIONAL LTD
Floor 6, Penrose Two,
Penrose Dock, Cork, T23 YY09, Ireland

© NETGEAR, Inc., NETGEAR and the NETGEAR Logo are trademarks of NETGEAR, Inc. Any non-NETGEAR trademarks are used for reference purposes only.