



## **Cisco UCS C225 M8 Server Installation and Service Guide**

**First Published:** 2025-01-24

### **Americas Headquarters**

Cisco Systems, Inc.  
170 West Tasman Drive  
San Jose, CA 95134-1706  
USA  
<http://www.cisco.com>  
Tel: 408 526-4000  
800 553-NETS (6387)  
Fax: 408 527-0883





## CONTENTS

---

### CHAPTER 1

#### **Overview 1**

- Overview 1
- External Features 4
- Component Location 6
- Summary of Server Features 8

---

### CHAPTER 2

#### **Installing the Server 11**

- Preparing for Installation 11
  - Installation Warnings and Guidelines 11
  - Rack Requirements 13
- Installing the Server in a Rack 13
  - Installing the Cable Management Arm (Optional) 17
  - Reversing the Cable Management Arm (Optional) 18
- Initial Server Setup 19
  - Connecting to the Server Locally For Setup 19
  - Connecting to the Server Remotely For Setup 20
  - Setting Up the System With the Cisco IMC Configuration Utility 22
- NIC Mode and NIC Redundancy Settings 24
- Updating the BIOS and Cisco IMC Firmware 25
- Accessing the System BIOS 26
- Smart Access Serial 26
- Smart Access USB 27

---

### CHAPTER 3

#### **Maintaining the Server 29**

- Status LEDs and Buttons 29
  - Front-Panel LEDs 30

Rear-Panel LEDs	32
Internal Diagnostic LEDs	33
Preparing For Component Installation	34
Required Equipment For Service Procedures	35
Shutting Down and Removing Power From the Server	35
Shutting Down Using the Power Button	35
Shutting Down Using The Cisco IMC CLI	36
Shutting Down Using The Cisco IMC GUI	36
Removing the Server Top Cover	37
Hot Swap vs Hot Plug	38
Removing and Replacing Components	39
Component Location	39
Replacing SAS/SATA Hard Drives or Solid State Drives	42
SAS/SATA Drive Population Guidelines	42
4K Sector Format SAS/SATA Drives Considerations	42
Replacing a SAS/SATA Drive	43
Replacing a Front-Loading NVMe SSD	44
Front-Loading NVMe SSD Population Guidelines	44
Front-Loading NVMe SSD Requirements and Restrictions	44
Enabling Hot-Plug Support in the System BIOS	44
Enabling Hot-Plug Support Using the BIOS Setup Utility	45
Replacing a Front-Loading NVMe SSD	45
Replacing Fan Modules	47
Replacing CPUs and Heatsinks	47
CPU Configuration Rules	48
Tools Required For CPU Replacement	48
Replacing a CPU and Heatsink	48
Additional CPU-Related Parts to Order with RMA Replacement CPUs	55
Replacing RAID Cards	55
Removing Cisco Trimode M1 24G RAID Controller W/4GB FBWC (16 Drives)	55
Installing Cisco Trimode M1 24G RAID Controller W/4GB FBWC (16 Drives)	57
Replacing Memory DIMMs	59
DIMM Population Rules and Memory Performance Guidelines	60
Replacing DIMMs	61

Replacing the RTC Battery	62
Replacing Power Supplies	63
Replacing AC Power Supplies	64
Replacing DC Power Supplies	65
Installing DC Power Supplies (First Time Installation)	66
Grounding for DC Power Supplies	68
Replacing a PCIe Riser	68
Replacing NVMe Cable	69
Replacing a PCIe Card	72
PCIe Slot Specifications	72
Replacing a PCIe Card	73
Cisco VIC mLOM and OCP Card Replacement Considerations	75
Replacing an mLOM Card	76
Replacing a SAS Storage Controller Card (RAID or HBA)	78
Storage Controller Card Firmware Compatibility	78
Replacing a SAS Storage Controller Card (RAID or HBA)	79
Replacing the Supercap (RAID Backup)	80
Replacing a Boot-Optimized M.2 RAID Controller Module	81
Replacing a Cisco Boot-Optimized M.2 RAID Controller	81
Replacing a Chassis Intrusion Switch	84
Installing a Trusted Platform Module (TPM)	86
TPM Considerations	86
Installing and Enabling a TPM	86
Installing TPM Hardware	86
Enabling the TPM in the BIOS	88
Removing the PCB Assembly (PCBA)	88
Service DIP Switch, Headers and Jumpers	89
Using the BIOS Recovery Header (SW4, Pins 5 - 17)	91
Procedure 1: Reboot With bios.cap Recovery File	91
Procedure 2: Use BIOS Recovery DIP Switch and bios.cap Recovery File	92
Using the Clear BIOS Password Switch (SW4, Pins 6 - 18)	93
Using the Clear CMOS DIP Switch (SW4, Pins 9 - 21)	94
Using the Boot Alternate Cisco IMC Image Header (CN5, Pins 1 - 2)	95
Using the Reset Cisco IMC Password to Default Header (CN5, Pins 3 - 4)	95

---

**CHAPTER 4**

**Recycling Server Components 97**

- Server Recycling and E-Waste 97
- Battery Warning 97
- Recycling the Main Motherboard PCB Assembly (PCBA) 97
- Recycling the Front Mezzanine Module PCBA (SAS Backplane) 99
- Recycling the Server KVM PCBA 100

---

**APPENDIX A**

**Server Specifications 103**

- Physical Specifications 103
- Environmental Specifications 103
- Power Specifications 105
  - 1050 W DC Power Supply 105
  - 1200 W AC Power Supply 106
  - 1600 W AC Power Supply 106
  - 2300 W AC Power Supply 107
- Power Cord Specifications 108

---

**APPENDIX B**

**Installation For Cisco UCS Manager Integration 111**

- Installation For Cisco UCS Manager Integration 111

---

**APPENDIX C**

**GPU Installation 113**

- Server Firmware Requirements 113
- GPU Card Configuration Rules 113
- Requirement For All GPUs: Memory-Mapped I/O Greater Than 4 GB 114
- Installing a Single-Wide GPU Card 114
- Using NVIDIA GRID License Server For L-Series GPUs 115
  - NVIDIA GRID License Server Overview 115
  - Downloading the GRID Software Suite 116
  - Registering Your Product Activation Keys With NVIDIA 117
  - Installing NVIDIA GRID License Server Software 117
  - Installing GRID Licenses From the NVIDIA Licensing Portal to the License Server 118
    - Reading Your License Server's MAC Address 118
    - Installing Licenses From the Licensing Portal 118

Viewing Available GRID Licenses	119
Viewing Current License Usage	119
Managing GRID Licenses	119
Acquiring a GRID License on Windows	119
Acquiring a GRID License on Linux	120
Using gpumodeswitch	121
Installing Drivers to Support the GPU Cards	121
1. Updating the Server BIOS	122
2. Updating the GPU Card Drivers	122

---

<b>APPENDIX D</b>	<b>Storage Controller Considerations</b>	<b>125</b>
	Storage Controller Cable Connectors and Backplanes	125





## Preface

---

This preface contains the following topics:

- [Bias-Free Documentation](#), on page ix
- [Full Cisco Trademarks with Hardware License](#), on page ix
- [Communications, Services, and Additional Information](#), on page xi

## Bias-Free Documentation



---

**Note** The documentation set for this product strives to use bias-free language. For purposes of this documentation set, bias-free is defined as language that does not imply discrimination based on age, disability, gender, racial identity, ethnic identity, sexual orientation, socioeconomic status, and intersectionality. Exceptions may be present in the documentation due to language that is hardcoded in the user interfaces of the product software, language used based on standards documentation, or language that is used by a referenced third-party product.

---

## Full Cisco Trademarks with Hardware License

THE SPECIFICATIONS AND INFORMATION REGARDING THE PRODUCTS IN THIS MANUAL ARE SUBJECT TO CHANGE WITHOUT NOTICE. ALL STATEMENTS, INFORMATION, AND RECOMMENDATIONS IN THIS MANUAL ARE BELIEVED TO BE ACCURATE BUT ARE PRESENTED WITHOUT WARRANTY OF ANY KIND, EXPRESS OR IMPLIED. USERS MUST TAKE FULL RESPONSIBILITY FOR THEIR APPLICATION OF ANY PRODUCTS.

THE SOFTWARE LICENSE AND LIMITED WARRANTY FOR THE ACCOMPANYING PRODUCT ARE SET FORTH IN THE INFORMATION PACKET THAT SHIPPED WITH THE PRODUCT AND ARE INCORPORATED HEREIN BY THIS REFERENCE. IF YOU ARE UNABLE TO LOCATE THE SOFTWARE LICENSE OR LIMITED WARRANTY, CONTACT YOUR CISCO REPRESENTATIVE FOR A COPY.

The following information is for FCC compliance of Class A devices: This equipment has been tested and found to comply with the limits for a Class A digital device, pursuant to part 15 of the FCC rules. These limits are designed to provide reasonable protection against harmful interference when the equipment is operated

in a commercial environment. This equipment generates, uses, and can radiate radio-frequency energy and, if not installed and used in accordance with the instruction manual, may cause harmful interference to radio communications. Operation of this equipment in a residential area is likely to cause harmful interference, in which case users will be required to correct the interference at their own expense.

The following information is for FCC compliance of Class B devices: This equipment has been tested and found to comply with the limits for a Class B digital device, pursuant to part 15 of the FCC rules. These limits are designed to provide reasonable protection against harmful interference in a residential installation. This equipment generates, uses and can radiate radio frequency energy and, if not installed and used in accordance with the instructions, may cause harmful interference to radio communications. However, there is no guarantee that interference will not occur in a particular installation. If the equipment causes interference to radio or television reception, which can be determined by turning the equipment off and on, users are encouraged to try to correct the interference by using one or more of the following measures:

- Reorient or relocate the receiving antenna.
- Increase the separation between the equipment and receiver.
- Connect the equipment into an outlet on a circuit different from that to which the receiver is connected.
- Consult the dealer or an experienced radio/TV technician for help.

Modifications to this product not authorized by Cisco could void the FCC approval and negate your authority to operate the product.

The Cisco implementation of TCP header compression is an adaptation of a program developed by the University of California, Berkeley (UCB) as part of UCB's public domain version of the UNIX operating system. All rights reserved. Copyright © 1981, Regents of the University of California.

NOTWITHSTANDING ANY OTHER WARRANTY HEREIN, ALL DOCUMENT FILES AND SOFTWARE OF THESE SUPPLIERS ARE PROVIDED "AS IS" WITH ALL FAULTS. CISCO AND THE ABOVE-NAMED SUPPLIERS DISCLAIM ALL WARRANTIES, EXPRESSED OR IMPLIED, INCLUDING, WITHOUT LIMITATION, THOSE OF MERCHANTABILITY, FITNESS FOR A PARTICULAR PURPOSE AND NONINFRINGEMENT OR ARISING FROM A COURSE OF DEALING, USAGE, OR TRADE PRACTICE.

IN NO EVENT SHALL CISCO OR ITS SUPPLIERS BE LIABLE FOR ANY INDIRECT, SPECIAL, CONSEQUENTIAL, OR INCIDENTAL DAMAGES, INCLUDING, WITHOUT LIMITATION, LOST PROFITS OR LOSS OR DAMAGE TO DATA ARISING OUT OF THE USE OR INABILITY TO USE THIS MANUAL, EVEN IF CISCO OR ITS SUPPLIERS HAVE BEEN ADVISED OF THE POSSIBILITY OF SUCH DAMAGES.

Any Internet Protocol (IP) addresses and phone numbers used in this document are not intended to be actual addresses and phone numbers. Any examples, command display output, network topology diagrams, and other figures included in the document are shown for illustrative purposes only. Any use of actual IP addresses or phone numbers in illustrative content is unintentional and coincidental.

All printed copies and duplicate soft copies of this document are considered uncontrolled. See the current online version for the latest version.

Cisco has more than 200 offices worldwide. Addresses and phone numbers are listed on the Cisco website at [www.cisco.com/go/offices](http://www.cisco.com/go/offices).

Cisco and the Cisco logo are trademarks or registered trademarks of Cisco and/or its affiliates in the U.S. and other countries. To view a list of Cisco trademarks, go to this URL: <https://www.cisco.com/c/en/us/about/legal/trademarks.html>. Third-party trademarks mentioned are the property of their respective owners. The use of the word partner does not imply a partnership relationship between Cisco and any other company. (1721R)

# Communications, Services, and Additional Information

- To receive timely, relevant information from Cisco, sign up at [Cisco Profile Manager](#).
- To get the business results you're looking for with the technologies that matter, visit [Cisco Services](#).
- To submit a service request, visit [Cisco Support](#).
- To discover and browse secure, validated enterprise-class apps, products, solutions and services, visit [Cisco DevNet](#).
- To obtain general networking, training, and certification titles, visit [Cisco Press](#).
- To find warranty information for a specific product or product family, access [Cisco Warranty Finder](#).

## Cisco Bug Search Tool

[Cisco Bug Search Tool](#) (BST) is a web-based tool that acts as a gateway to the Cisco bug tracking system that maintains a comprehensive list of defects and vulnerabilities in Cisco products and software. BST provides you with detailed defect information about your products and software.





# CHAPTER 1

## Overview

---

- [Overview, on page 1](#)
- [External Features, on page 4](#)
- [Component Location, on page 6](#)
- [Summary of Server Features, on page 8](#)

## Overview

The Cisco UCS C225 M8 Server is a high-density, 1RU, single-socket rack server designed for versatile infrastructure and application deployment. This server can operate as a standalone unit or as part of the Cisco Unified Computing System (UCS), which integrates computing, networking, management, virtualization, and storage into a cohesive architecture. The UCS architecture facilitates end-to-end visibility, management, and control across both bare-metal and virtualized environments.

The Cisco UCS C225 M8 Server is orderable in two versions:

- Small form-factor (SFF) drives version (UCSC-C225-M8S):
  - Supports up to 10 front-loading 2.5-inch SAS/SATA or NVMe U.3 drives.
  - Optionally supports direct-attach NVMe SSDs in the first four bays.
- NVMe drives version (UCSC-C225-M8N):
  - Supports up to 10 front-loading 2.5-inch NVMe SSDs.

### Technical Specifications

- **CPU Support**
  - 4th Gen AMD EPYC™ processors, with up to 128 cores.
  - 5th Gen AMD EPYC™ processors, with up to 160 cores.
- **Memory**
  - Up to 12 DIMM slots.
  - Supports 4th Gen AMD EPYC processors and DDR5 memory with speeds up to 4800 MT/s.

- Supports 5th Gen AMD EPYC processors and DDR5 memory with speeds up to 6000 MT/s.
- Maximum memory capacity of 3 TB using 256 GB DIMMs.

- **Storage Options**

- **SFF Version:**

- Up to 10 drives with a mix of SAS/SATA/NVMe U.3.
    - Tri-mode RAID controller supports SAS4/NVMe hardware RAID.

- **NVMe Version:**

- Up to 10 direct-attach NVMe SSDs.

- **PCIe Expansion and Riser Options**

- Supports up to three PCIe 4.0 slots or up to two PCIe 5.0 slots.

- **Riser Options for 3 HH Riser Cage Support:**

- **Riser 1:**

- Riser 1A (PCIe Gen4): Half-height, 3/4 length, x16, NCSI, Single Wide GPU.
      - Riser 1B (PCIe Gen5): Half-height, 3/4 length, x16, NCSI, Single Wide GPU.

- **Riser 2:**

- Riser 2A (PCIe Gen4): Half-height, 3/4 length, x16, Single Wide GPU.
      - Riser 2B (PCIe Gen5): Half-height, 3/4 length, x16, Single Wide GPU.

- **Riser 3:**

- Riser 3A (PCIe Gen4): Half-height, 3/4 length, x16, NCSI, Single Wide GPU.

- **Riser Options for 2 FH Riser Cage Support:**

- **Riser 1:**

- Riser 1C (PCIe Gen5): Full-height, 3/4 length, x16, NCSI, Single Wide GPU.

- **Riser 3:**

- Riser 3C (PCIe Gen5): Full-height, 3/4 length, x16, NCSI, Single Wide GPU.

- **Management**

- Includes a dedicated management port for out-of-band management.
  - Supports Cisco Intersight and UCS Manager for unified management.

- **Storage Controllers**

- **Internal Storage Controllers:**

- Cisco 24G Tri-mode RAID controller RAID Support: RAID 0, 1, 5, 6, 10, 50, 60, RAID 0, and RAID 00
- Supports up to 10 internal SAS/SATA/NVMe drives.
- **External Storage Controllers:** Cisco 12G 9500-8e 12G SAS HBA for external JBOD attach.
- **Supported VIC Cards:**
  - UCSC-M-V5Q50GV2-D: Cisco UCS VIC 15427 Quad Port CNA MLOM with Secure Boot (mLOM, HHHL, SS)
  - UCSC-O-ID10GC: Intel X710T2LOCPV3G1L 2x10GbE RJ45 OCP3.0 NIC (mLOM/OCP 3.0 slot)
  - UCSC-P-V5Q50G-D: Cisco UCS VIC 15425 Quad Port 10/25/50G CNA PCIE (Riser 1 or 2, HHHL, SS)
  - UCSC-P-V5D200G-D: Cisco UCS VIC 15235 Dual Port 40/100/200G CNA PCIE (Riser 1 or 2, HHHL, SS)
- **Network Interface Cards (NICs):**
  - 1 GbE NICs: UCSC-P-IQ1GC: Cisco-Intel I710-T4L 4x1GBASE-T NIC (Riser 1, 2, or 3, HHHL, SS)
  - 10 GbE NICs:
    - UCSC-PCIEID10GF-D: Intel X710-DA2 Dual Port 10Gb SFP+ NIC (Riser 1, 2, or 3, HHHL, SS)
    - UCSC-P-ID10GC-D: Cisco-Intel X710T2LG 2x10 GbE RJ45 PCIe NIC (Riser 1, 2, or 3, HHHL, SS)
    - UCSC-P-IQ10GC-D: Cisco-Intel X710T4LG 4x10 GbE RJ45 PCIe NIC (Riser 1, 2, or 3, HHHL, SS)
    - UCSC-PCIEIQ10GF-D: Intel X710 quad-port 10G SFP+ NIC (Riser 1, 2, or 3, HHHL, SS)
  - 25 GbE NICs:
    - UCSC-P-I8D25GF-D: Cisco-Intel E810XXVDA2 2x25/10 GbE SFP28 PCIe NIC (Riser 1, 2, or 3, HHHL, SS)
    - UCSC-P-I8Q25GF-D: Cisco-Intel E810XXVDA4L 4x25/10 GbE SFP28 PCIe NIC (Riser 1, 2, or 3, HHHL, SS)
    - UCSC-P-N7Q25GF: MCX713104AS-ADAT: CX-7 4x25GbE SFP56 PCIe Gen4x16, VPI NIC
    - 25GbE NICs: UCSC-P-N6D25GF: Cisco-NVDA MCX631102AS-ADAT CX6Lx 2x25GbE SFP28 x8 PCIe NIC
  - 100 Gbe NICs:
    - UCSC-P-M6CD100GF: Cisco-MLNX MCX623106AC-CDAT 2x100GbE QSFP56 PCIe NIC
  - 200Gbe NICs:

- UCSC-P-N7D200GF: Cisco-NVDA MCX755106AS-HEAT CX7 2x200GbE QSFP112 PCIe Gen5x 16, PCIe NIC

# External Features

## Cisco UCS C225 M8 Server Front Panel Features

The following figure shows the front panel features of the small form-factor drive versions of the server.

For definitions of LED states, see [Front-Panel LEDs](#), on page 30.

Figure 1: Cisco UCS C225 M8 Server Front Panel

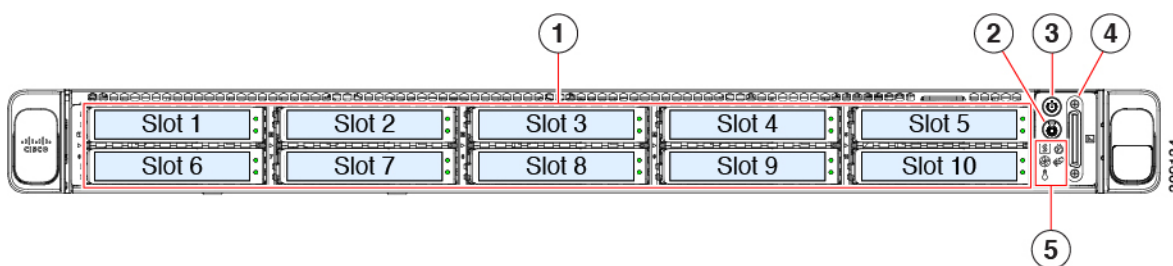

1	UCSC-C225-M8S Version—Drive bays 1 – 10 support SAS/SATA hard disk drives (HDDs) and solid state drives (SSDs). As an option, drive bays 1-4 can contain up to 4 NVMe drives in any number up to 4. Drive bays 5 through 10 support only SAS/SATA HDDs or SSDs.  UCSC-C225-M8N Version—Drive bays 1—10 supports 2.5-inch NVMe-only SSDs.	2	Unit identification button/LED
3	Power button/power status LED	4	KVM connector (used with KVM cable that provides one DB-15 VGA, one DB-9 serial, and two USB 2.0 connectors)
5	System LED cluster: <ul style="list-style-type: none"> <li>• Fan status LED</li> <li>• System Status LED</li> <li>• Power supply status LED</li> <li>• Network link activity LED</li> <li>• Temperature status LED</li> </ul>		-

## Cisco UCS C225 M8 Server Rear Panel Features

The rear panel features can be different depending on the number and type of PCIe cards in the server.

The following figure shows the rear panel features of the server with three riser configuration.

For definitions of LED states, see [Rear-Panel LEDs, on page 32](#).

**Figure 2: Cisco UCS C225 M8 Server Rear Panel Three-Riser Configuration**

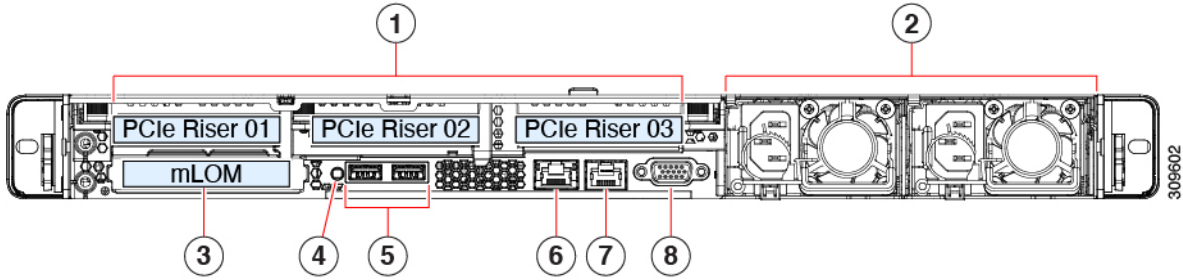

The following figure shows the rear panel features of the server with two riser configuration.

**Figure 3: Cisco UCS C225 M8 Server Rear Panel Two-Riser Configuration**

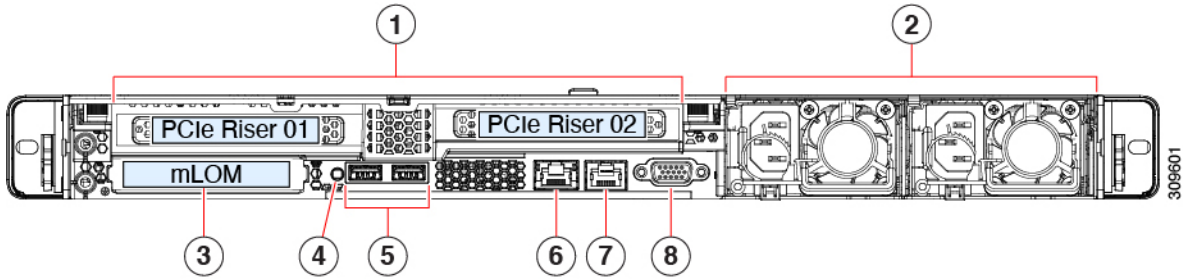

1	<p>PCIe slots</p> <p>Following PCIe Riser combinations are available for 3 HH Riser cage configuration:</p> <ul style="list-style-type: none"> <li>• <b>Riser 1:</b> <ul style="list-style-type: none"> <li>• Riser 1A (PCIe Gen4): Half-height, 3/4 length, x16, NCSI, Single Wide GPU.</li> <li>• Riser 1B (PCIe Gen5): Half-height, 3/4 length, x16, NCSI, Single Wide GPU.</li> </ul> </li> <li>• <b>Riser 2:</b> <ul style="list-style-type: none"> <li>• Riser 2A (PCIe Gen4): Half-height, 3/4 length, x16, Single Wide GPU.</li> <li>• Riser 2B (PCIe Gen5): Half-height, 3/4 length, x16, Single Wide GPU.</li> </ul> </li> <li>• <b>Riser 3:</b> <ul style="list-style-type: none"> <li>• Riser 3A (PCIe Gen4): Half-height, 3/4 length, x16, NCSI, Single Wide GPU.</li> </ul> </li> </ul> <p>Following PCIe Riser combinations are available for 2 FH Riser cage configuration:</p> <ul style="list-style-type: none"> <li>• <b>Riser 1:</b> <ul style="list-style-type: none"> <li>• Riser 1C (PCIe Gen5): Full-height, 3/4 length, x16, NCSI, Single Wide GPU.</li> </ul> </li> <li>• <b>Riser 3:</b> <ul style="list-style-type: none"> <li>• Riser 3C (PCIe Gen5): Full-height, 3/4 length, x16, NCSI, Single Wide GPU.</li> </ul> </li> </ul>		
2	Power supply units (PSUs), two, which can be redundant when configured in 1+1 power mode.	3	Modular LAN-on-motherboard (mLOM) card bay (x16 PCIe lane)
4	System identification button/LED	5	USB 3.0 ports (two)
6	Dedicated 1 GB Ethernet management port	7	COM port (RJ-45 connector)
8	VGA video port (DB-15 connector)		

## Component Location

This topic shows the locations of the field-replaceable components and service-related items. The view in the following figure shows the server with the top cover removed.

Figure 4: Cisco UCS C225 M8 Server, Two Riser Configuration Serviceable Component Locations

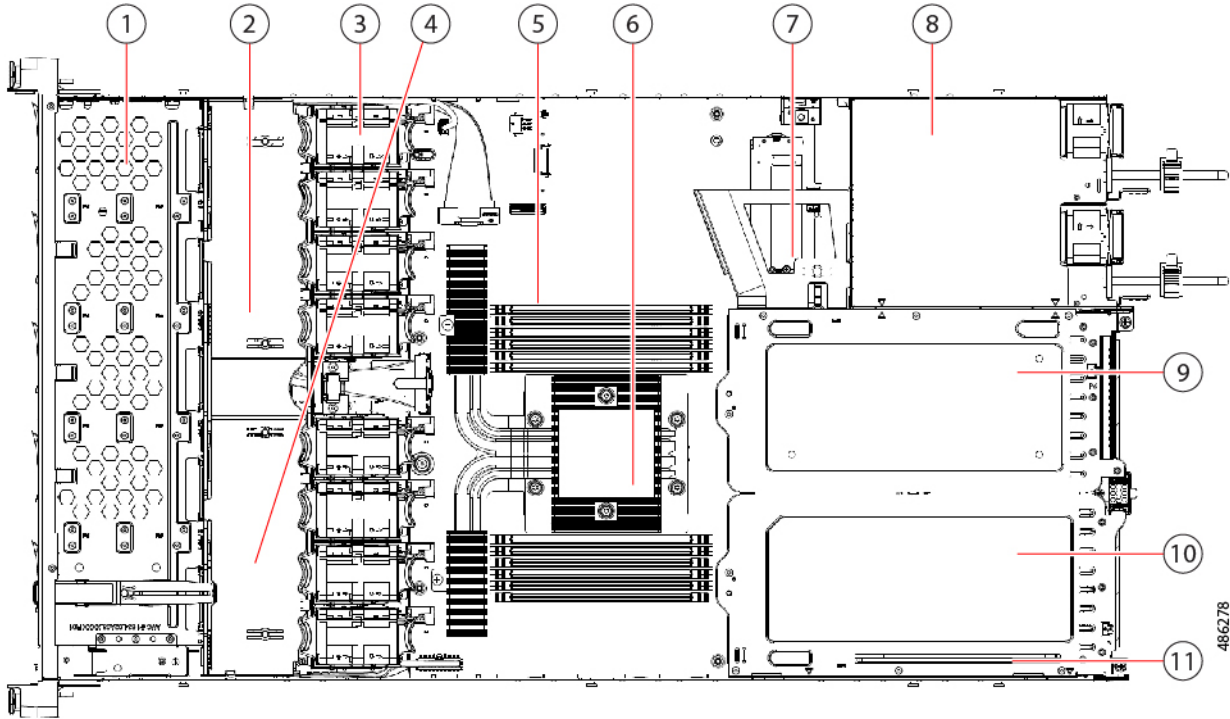

486278

1	Front-loading drive bays 1–10 support SAS/SATA/NVMe drives.	2	Cisco 24G Tri-mode RAID controller
3	Cooling fan modules, eight. Each fan is hot-swappable	4	SuperCap module mounting bracket The SuperCap module (not shown) that mounts into this location provides RAID write-cache backup.
5	DIMM sockets on motherboard, 12 total.	6	Motherboard CPU socket
7	M.2 module connector Supports a boot-optimized RAID controller with connectors for up to two SATA M.2 SSDs	8	Power Supply Units (PSUs), two
9	PCIe riser slot 2	10	PCIe riser slot 1
11	Modular LOM (mLOM) card bay on chassis floor (x16 PCIe lane)		

Figure 5: Cisco UCS C225 M8 Server Three Riser Configuration Serviceable Component Locations

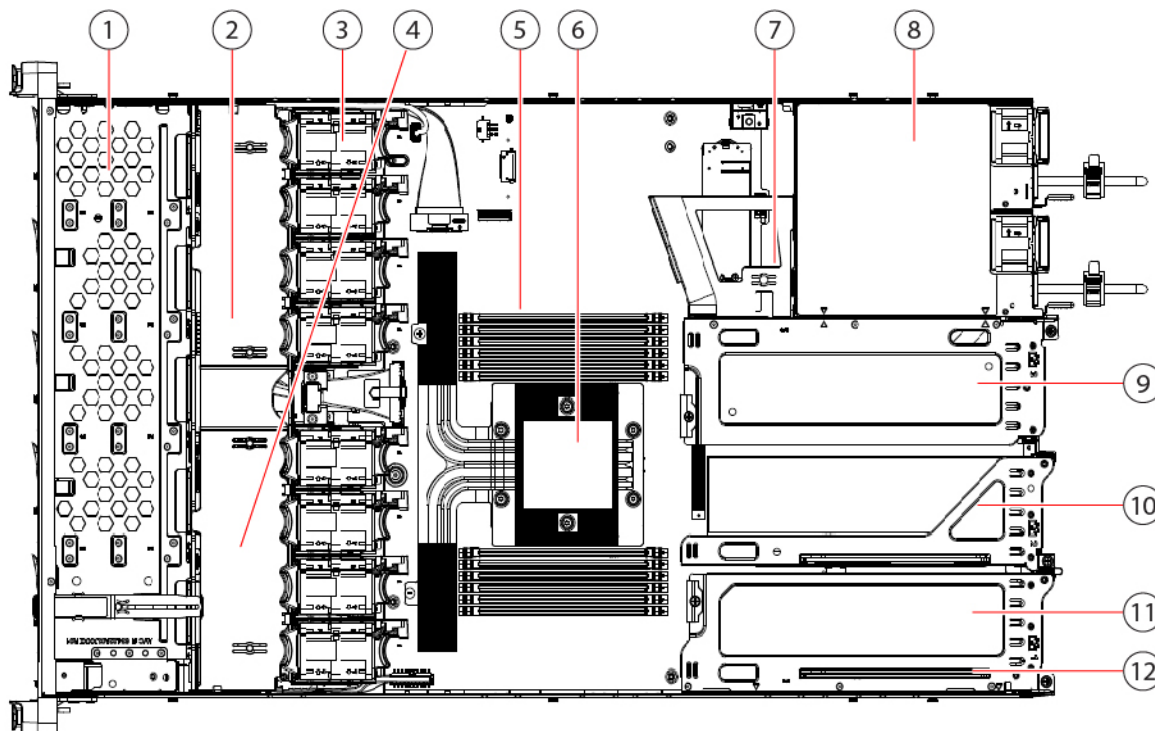

486279

1	Front-loading drive bays 1–10 support SAS/SATA/NVMe drives.	2	Cisco M8 24G SAS RAID card or Cisco M8 24G SAS HBA Controller
3	Cooling fan modules, eight. Each fan is hot-swappable	4	SuperCap module mounting bracket The SuperCap module (not shown) that mounts into this location provides RAID write-cache backup.
5	DIMM sockets on motherboard, 12 total.	6	Motherboard CPU socket
7	M.2 module connector Supports a boot-optimized RAID controller with connectors for up to two SATA M.2 SSDs	8	Power Supply Units (PSUs), two
9	PCIe riser slot 3	10	PCIe riser slot 2
11	PCIe riser slot 1	12	Modular LOM (mLOM) card bay on chassis floor (x16 PCIe lane)

## Summary of Server Features

The following table lists a summary of server features for the Cisco UCS C225 M8 Server.

Feature	Description
Chassis	One rack-unit (1RU) chassis.
Central Processor	One socket, 4th Gen AMD EPYC™ processors, with up to 128 cores. One socket, 5th Gen AMD EPYC™ processors, with up to 160 cores.
Memory	Up to 12 DIMM slots per CPU, supports DDR5 memory with speeds up to 4800 MT/s, maximum memory capacity of 3 TB using 256 GB DIMMs. Up to 12 DIMM slots per CPU, supports DDR5 memory with speeds up to 6000 MT/s, maximum memory capacity of 1U Max supportd 12 DIMMs 3 TB using 256 GB DIMMs.
Multi-bit error protection	Multi-bit error protection is supported.
Video	The Cisco Integrated Management Controller (CIMC) provides video using the Matrox G200e video/graphics controller: <ul style="list-style-type: none"> <li>• Integrated 2D graphics core with hardware acceleration.</li> <li>• Embedded DDR memory interface supports up to 512 MB of addressable memory (8 MB is allocated by default to video memory).</li> <li>• Supports display resolutions up to 1920 x 1200 16bpp @ 60Hz.</li> <li>• High-speed integrated 24-bit RAMDAC.</li> <li>• Single lane PCI-Express host interface running at Gen 1 speed.</li> </ul>
Baseboard management	BMC, running Cisco Integrated Management Controller (Cisco IMC) firmware. Depending on your Cisco IMC settings, Cisco IMC can be accessed through the 1-Gb dedicated management port or a Cisco virtual interface card.
Network and management I/O	Rear panel: <ul style="list-style-type: none"> <li>• One 1-Gb Ethernet dedicated management port (RJ-45 connector).</li> <li>• One RS-232 serial port (RJ-45 connector).</li> <li>• One VGA video connector port (DB-15 connector).</li> <li>• Two USB 3.0 ports.</li> <li>• One flexible modular LAN on motherboard (mLOM)/OCP 3.0 slot that can accommodate various interface cards.</li> </ul> Front panel: <ul style="list-style-type: none"> <li>• One KVM console connector (supplies two USB 2.0 connectors, one VGA DB15 video connector, and one serial port (RS232) RJ45 connector).</li> </ul>

Feature	Description
Modular LAN on Motherboard (mLOM)/ OCP3 3.0 slot	<p>The dedicated mLOM/OCP 3.0 slot on the motherboard can flexibly accommodate the following cards:</p> <ul style="list-style-type: none"> <li>• Cisco Virtual Interface Cards, Series 15xxx mLOM/VICs at speeds of 10G/25G/40G/50G/100G/200G depending on the mLOM/VIC installed.</li> <li>• OCP 3.0 network interface card (UCSC-O-ID10GC).</li> </ul>
Power	<p>Up to two of the following hot-swappable power supplies:</p> <ul style="list-style-type: none"> <li>• 1050 W DC.</li> <li>• 1200 W (AC).</li> <li>• 1600 W (AC).</li> <li>• 2300 W (AC).</li> </ul> <p>One power supply is mandatory; one more can be added for 1 + 1 redundancy.</p>
ACPI	The advanced configuration and power interface (ACPI) 4.0 standard is supported.
Front Panel	The front panel controller provides status indications and control buttons.
Cooling	Eight hot-swappable fan modules for front-to-rear cooling.
InfiniBand	The PCIe bus slots in this server support the InfiniBand architecture.
Expansion Slots	<p>The server supports either of the following configurations:</p> <p>Three half-height riser slots that support up to three add-in cards:</p> <ul style="list-style-type: none"> <li>• Riser 1: One x16 PCIe Gen4/Gen5 Slot, half-height.</li> <li>• Riser 2: One x16 PCIe Gen4/Gen5 Slot, half-height.</li> <li>• Riser 3: One x16 PCIe Gen4 Slot, half-height.</li> </ul> <p>Or for the two full height version:</p> <ul style="list-style-type: none"> <li>• Riser 1: One x16 PCIe Gen5 Slot, full-height.</li> <li>• Riser 3: One x16 PCIe Gen5 Slot, full-height.</li> </ul>



## CHAPTER 2

# Installing the Server

---

- [Preparing for Installation, on page 11](#)
- [Installing the Server in a Rack, on page 13](#)
- [Initial Server Setup, on page 19](#)
- [NIC Mode and NIC Redundancy Settings, on page 24](#)
- [Updating the BIOS and Cisco IMC Firmware, on page 25](#)
- [Accessing the System BIOS, on page 26](#)
- [Smart Access Serial, on page 26](#)
- [Smart Access USB, on page 27](#)

## Preparing for Installation

This section contains the following topics:

### Installation Warnings and Guidelines



---

**Note**

Before you install, operate, or service a server, review the [Regulatory Compliance and Safety Information for Cisco UCS C-Series Servers](#) for important safety information.

---



---

**Warning****IMPORTANT SAFETY INSTRUCTIONS**

**This warning symbol means danger. You are in a situation that could cause bodily injury. Before you work on any equipment, be aware of the hazards involved with electrical circuitry and be familiar with standard practices for preventing accidents. Use the statement number provided at the end of each warning to locate its translation in the translated safety warnings that accompanied this device.**

Statement 1071

---



---

**Warning** To prevent the system from overheating, do not operate it in an area that exceeds the maximum recommended ambient temperature of: 35° C (95° F).

Statement 1047

---



---

**Warning** The plug-socket combination must be accessible at all times, because it serves as the main disconnecting device.

Statement 1019

---



---

**Warning** This product relies on the building's installation for short-circuit (overcurrent) protection. Ensure that the protective device is rated not greater than: 250 V, 15 A.

Statement 1005

---



---

**Warning** Installation of the equipment must comply with local and national electrical codes.

Statement 1074

---



---

**Warning** This unit is intended for installation in restricted access areas. A restricted access area can be accessed only through the use of a special tool, lock, and key, or other means of security.

Statement 1017

---



---

**Caution** To ensure proper airflow it is necessary to rack the servers using rail kits. Physically placing the units on top of one another or “stacking” without the use of the rail kits blocks the air vents on top of the servers, which could result in overheating, higher fan speeds, and higher power consumption. We recommend that you mount your servers on rail kits when you are installing them into the rack because these rails provide the minimal spacing required between the servers. No additional spacing between the servers is required when you mount the units using rail kits.

---



---

**Caution** Avoid uninterruptible power supply (UPS) types that use ferroresonant technology. These UPS types can become unstable with systems such as the Cisco UCS, which can have substantial current draw fluctuations from fluctuating data traffic patterns.

---

When you are installing a server, use the following guidelines:

- Plan your site configuration and prepare the site before installing the server. See the [Cisco UCS Site Preparation Guide](#) for the recommended site planning tasks.

- Ensure that there is adequate space around the server to allow for accessing the server and for adequate airflow. The airflow in this server is from front to back.
- Ensure that the air-conditioning meets the thermal requirements listed in the [Environmental Specifications, on page 103](#).
- Ensure that the cabinet or rack meets the requirements listed in the [Rack Requirements, on page 13](#).
- Ensure that the site power meets the power requirements listed in the [Power Specifications, on page 105](#). If available, you can use an uninterruptible power supply (UPS) to protect against power failures.

## Rack Requirements

The rack must be of the following type:

- A standard 19-in. (48.3-cm) wide, four-post EIA rack, with mounting posts that conform to English universal hole spacing, per section 1 of ANSI/EIA-310-D-1992.
- The rack-post holes can be square 0.38-inch (9.6 mm), round 0.28-inch (7.1 mm), #12-24 UNC, or #10-32 UNC when you use the Cisco-supplied slide rails.
- The minimum vertical rack space per server must be one rack unit (RU), equal to 1.75 in. (44.45 mm).

### Supported Cisco Slide Rail Kits

The server supports the following rail kit options:

- Cisco part UCSC-RAILB-M6= (ball-bearing slide rail kit)
- Cisco part UCSC-RAILF-M6= (friction slide rail kit)
- Cisco part UCSC-CMAF-M6= (cable management arm)

### Rack Installation Tools Required

The slide rails sold by Cisco Systems for this server do not require tools for installation.

### Slide Rail and Cable Management Arm Dimensions

The slide rails for this server have an adjustment range of 24 to 36 inches (610 to 914 mm).

The optional cable management arm (CMA) adds additional length requirements:

- The additional distance from the rear of the server to the rear of the CMA is 5.4 inches (137.4 mm).
- The total length of the server including the CMA is 35.2 inches (894 mm).

## Installing the Server in a Rack

This section describes how to install the server in a rack using the supported rail kit (UCSC-RAIL-M6) that is sold by Cisco.

**Warning**

To prevent bodily injury when mounting or servicing this unit in a rack, you must take special precautions to ensure that the system remains stable. The following guidelines are provided to ensure your safety:

This unit should be mounted at the bottom of the rack if it is the only unit in the rack.

When mounting this unit in a partially filled rack, load the rack from the bottom to the top with the heaviest component at the bottom of the rack.

If the rack is provided with stabilizing devices, install the stabilizers before mounting or servicing the unit in the rack.

Statement 1006

**Procedure**

**Step 1** Attach the inner rails to the sides of the server:

- a) Align an inner rail with one side of the server so that the three keyed slots in the rail align with the three pegs on the side of the server.
- b) Set the keyed slots over the pegs, and then slide the rail toward the front to lock it in place on the pegs.
- c) Install the second inner rail to the opposite side of the server.

**Figure 6: Attaching the Inner Rail to the Side of the Server**

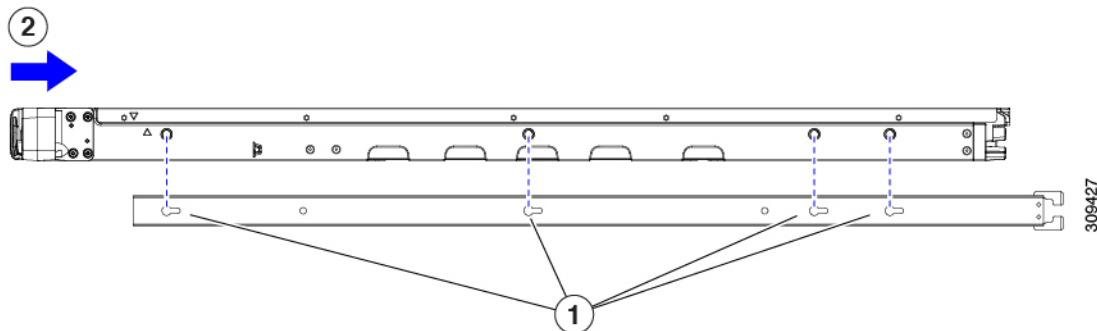

<b>1</b>	Keyed slots in rail	<b>2</b>	Front of server slides into keyed slots
----------	---------------------	----------	---

**Step 2** Open the front securing plate on both slide-rail assemblies. The front end of the slide-rail assembly has a spring-loaded securing plate that must be open before you can insert the mounting pegs into the rack-post holes.

On the *outside* of the assembly, push the green-arrow button toward the rear to open the securing plate.

Figure 7: Front Securing Mechanism, Inside of Front End

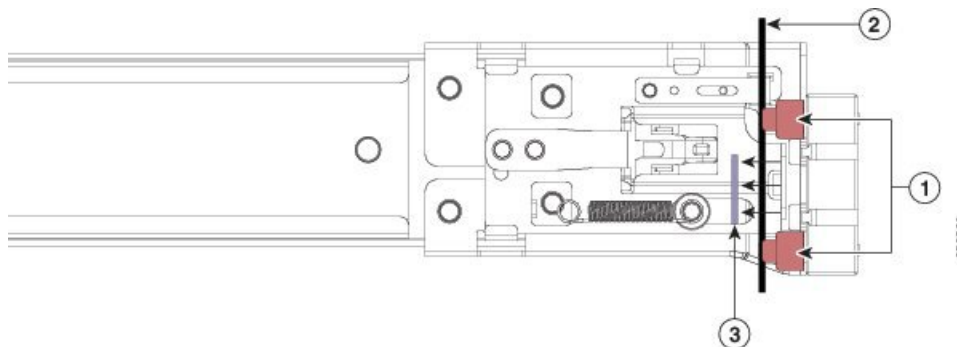

<b>1</b>	Front mounting pegs	<b>3</b>	Securing plate shown pulled back to the open position
<b>2</b>	Rack post between mounting pegs and opened securing plate	-	

### Step 3

Install the outer slide rails into the rack:

- a) Align one slide-rail assembly front end with the front rack-post holes that you want to use.

The slide rail front-end wraps around the outside of the rack post and the mounting pegs enter the rack-post holes from the outside-front.

**Note**

The rack post must be between the mounting pegs and the *open* securing plate.

- b) Push the mounting pegs into the rack-post holes from the outside-front.  
 c) Press the securing release button, marked PUSH. The spring-loaded securing plate closes to lock the pegs in place.  
 d) Adjust the slide-rail length, and then push the rear mounting pegs into the corresponding rear rack-post holes. The slide rail must be level front-to-rear.

The rear mounting pegs enter the rear rack-post holes from the *inside* of the rack post.

- e) Attach the second slide-rail assembly to the opposite side of the rack. Ensure that the two slide-rail assemblies are at the same height and are level front-to-back.  
 f) Pull the inner slide rails on each assembly out toward the rack front until they hit the internal stops and lock in place.

### Step 4

Insert the server into the slide rails:

**Caution**

This server can weigh up to 60 pounds (27 kilograms) when fully loaded with components. We recommend that you use a minimum of two people or a mechanical lift when lifting the server. Attempting this procedure alone could result in personal injury or equipment damage.

- a) Align the rear ends of the inner rails that are attached to the server sides with the front ends of the empty slide rails on the rack.

b) Push the inner rails into the slide rails on the rack until they stop at the internal

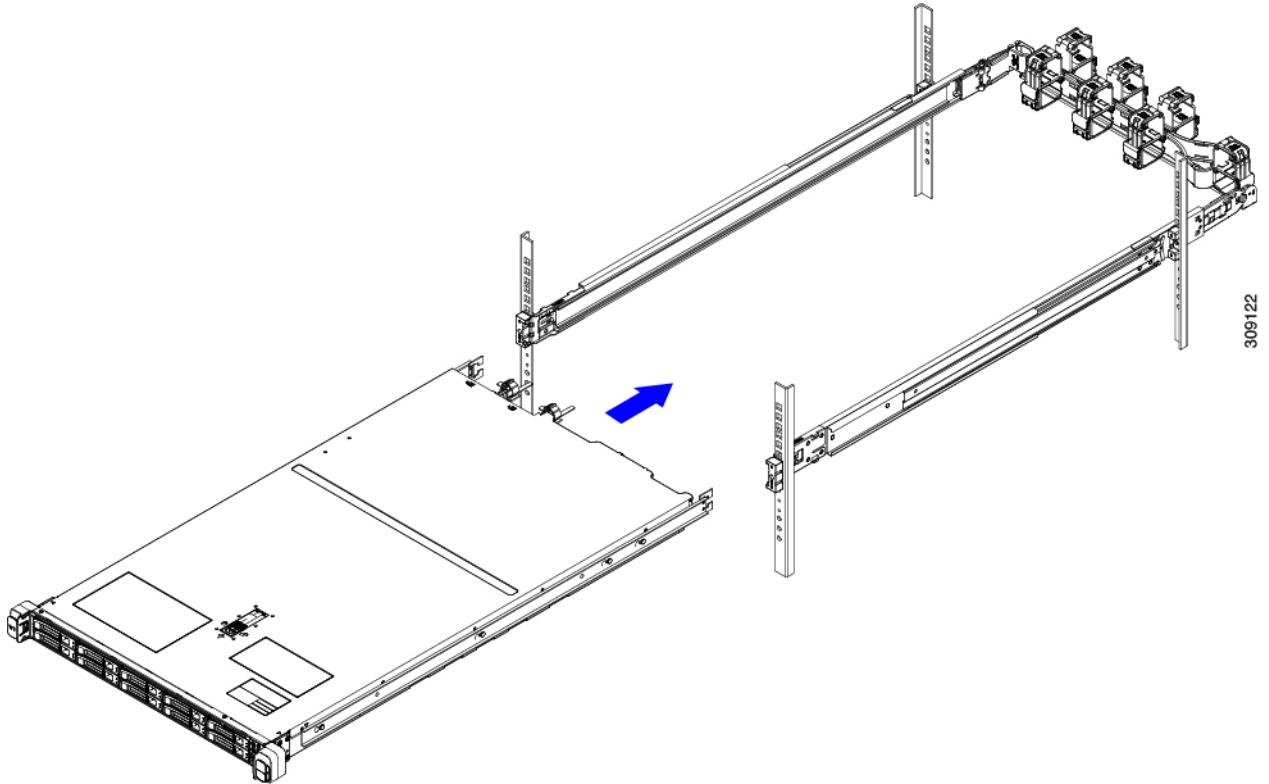

c) Slide the inner-rail release clip toward the rear on both inner rails, and then continue pushing the server into the rack until its front slam-latches engage with the rack posts.

Figure 8: Inner-Rail Release Clip

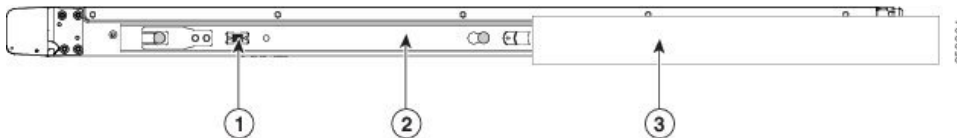

1	Inner-rail release clip	3	Outer slide rail attached to rack post
2	Inner rail attached to server and inserted into outer slide rail	-	

**Step 5** (Optional) Secure the server in the rack more permanently by using the two screws that are provided with the slide rails. Perform this step if you plan to move the rack with servers installed.

With the server fully pushed into the slide rails, open a hinged slam latch lever on the front of the server and insert a screw through the hole that is under the lever. The screw threads into the static part of the rail on the rack post and prevents the server from being pulled out. Repeat for the opposite slam latch.

**Step 6** (Optional) If applicable, do the following:

a) Attach the cable management arm. Go to [Installing the Cable Management Arm \(Optional\)](#), on page 17 or [Reversing the Cable Management Arm \(Optional\)](#), on page 18.

- b) Attach the locking bezel.

## Installing the Cable Management Arm (Optional)



**Note** The cable management arm (CMA) is reversible left-to-right. To reverse the CMA, see [Reversing the Cable Management Arm \(Optional\)](#), on page 18 before installation.

### Procedure

- Step 1** With the server pushed fully into the rack, slide the CMA tab of the CMA arm that is farthest from the server onto the end of the stationary slide rail that is attached to the rack post. Slide the tab over the end of the rail until it clicks and locks.

*Figure 9: Attaching the CMA to the Rear Ends of the Slide Rails*

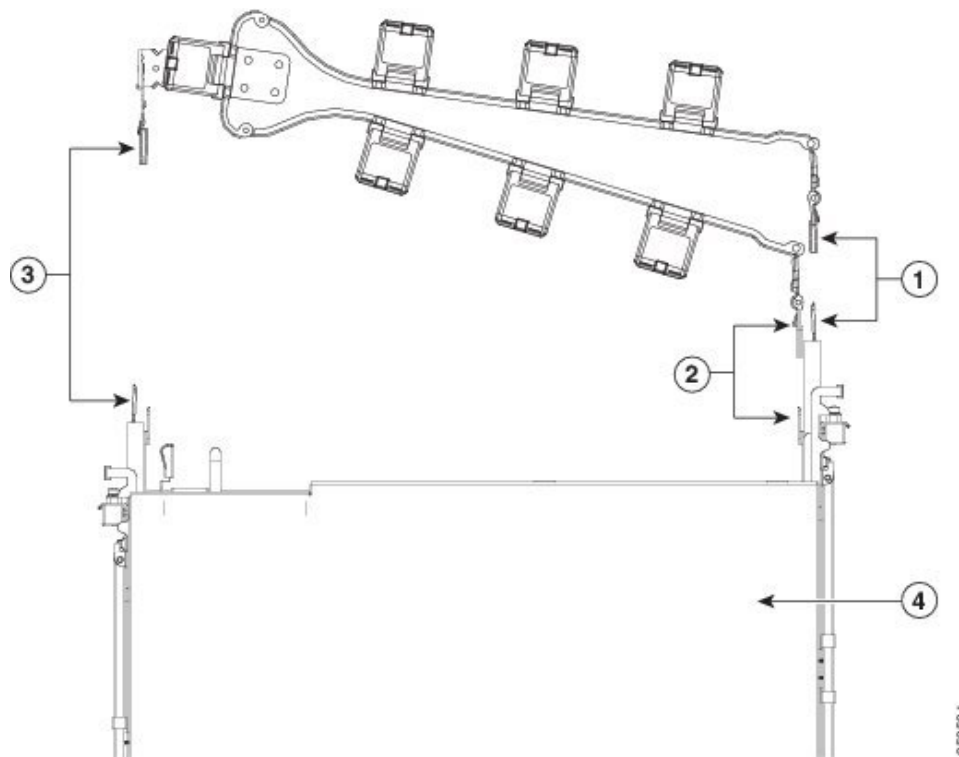

1	CMA tab on arm farthest from server attaches to end of stationary outer slide rail.	3	CMA tab on width-adjustment slider attaches to end of stationary outer slide rail.
2	CMA tab on arm closest to the server attaches to end of inner slide rail attached to server.	4	Rear of server

- Step 2** Slide the CMA tab that is closest to the server over the end of the inner rail that is attached to the server. Slide the tab over the end of the rail until it clicks and locks.
- Step 3** Pull out the width-adjustment slider that is at the opposite end of the CMA assembly until it matches the width of your rack.
- Step 4** Slide the CMA tab that is at the end of the width-adjustment slider onto the end of the stationary slide rail that is attached to the rack post. Slide the tab over the end of the rail until it clicks and locks.
- Step 5** Open the hinged flap at the top of each plastic cable guide and route your cables through the cable guides as desired.

## Reversing the Cable Management Arm (Optional)

### Procedure

- Step 1** Rotate the entire CMA assembly 180 degrees, left-to-right. The plastic cable guides must remain pointing upward.
- Step 2** Flip the tabs at the ends of the CMA arms so that they point toward the rear of the server.
- Step 3** Pivot the tab that is at the end of the width-adjustment slider. Depress and hold the metal button on the outside of the tab and pivot the tab 180 degrees so that it points toward the rear of the server.

**Figure 10: Reversing the CMA**

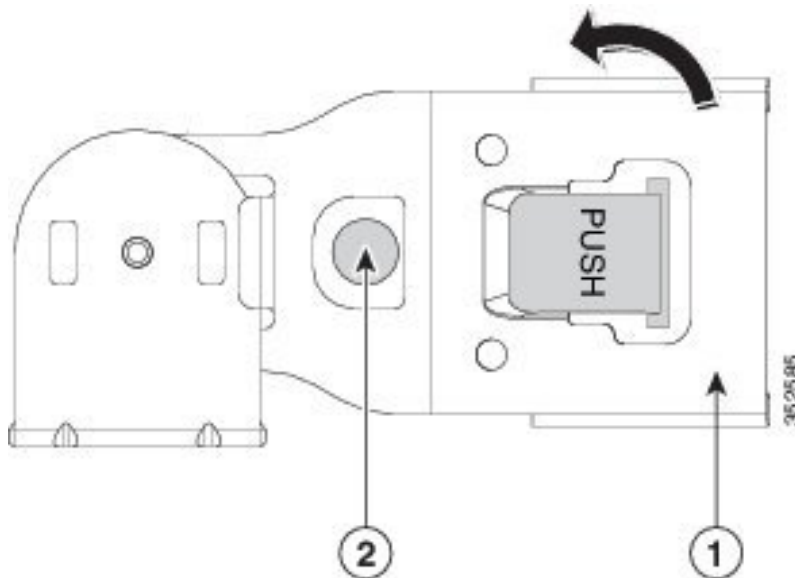

1	CMA tab on end of width-adjustment slider	2	Metal button on outside of tab
---	---	---	--------------------------------

# Initial Server Setup



---

**Note** This section describes how to power on the server, assign an IP address, and connect to server management when using the server in standalone mode.

---

## Server Default Settings

The server is shipped with these default settings:

- If the server does not have any VIC card, the default NIC mode is **Dedicated**. If the server has a VIC card in Riser 1 slot, the default NIC mode is **OCP**, but the VIC precedence first goes to MLOM, then Riser 1, and then Riser 2.  
  
If you want to use the dedicated management ports to access Cisco IMC, you can connect to the server and change the NIC mode as described in [Setting Up the System With the Cisco IMC Configuration Utility, on page 22](#).
- In *Dedicated* mode, NIC redundancy is set to *None*. In *Cisco Card* mode, the NIC redundancy is set to *Active-Active*. All Ethernet ports are utilized simultaneously.
- DHCP is enabled.
- IPv4 and IPv6 are enabled.

## Connection Methods

There are two methods for connecting to the system for initial setup:

- Local setup—Use this procedure if you want to connect a keyboard and monitor directly to the system for setup. This procedure can use the VGA and USB ports on the front of the server.
- Remote setup—Use this procedure if you want to perform setup through your dedicated management LAN.



---

**Note** To configure the system remotely, you must have a DHCP server on the same network as the system. Your DHCP server must be preconfigured with the range of MAC addresses for this server node. The MAC address is printed on a label that is on the pull-out asset tag on the front panel. This server node has a range of six MAC addresses assigned to the Cisco IMC. The MAC address printed on the label is the beginning of the range of six contiguous MAC addresses.

---

## Connecting to the Server Locally For Setup

This procedure requires the following equipment:

- VGA monitor

- USB keyboard
- Either the supported Cisco KVM cable (Cisco PID N20-BKVM); or a USB cable and VGA DB-15 cable

## Procedure

---

- Step 1** Attach a power cord to each power supply in your server, and then attach each power cord to a grounded power outlet. Wait for approximately two minutes to let the server boot to standby power during the first bootup. You can verify system power status by looking at the system Power Status LED on the front panel. The system is in standby power mode when the LED is amber.
- Step 2** Connect a USB keyboard and VGA monitor to the server using one of the following methods:
- Connect an optional KVM cable (Cisco PID N20-BKVM) to the KVM connector on the front panel. Connect your USB keyboard and VGA monitor to the KVM cable.
  - Connect a USB keyboard and VGA monitor to the corresponding connectors on the rear panel.
- Step 3** Open the Cisco IMC Configuration Utility:
- a) Press and hold the front panel power button for four seconds to boot the server.
  - b) During bootup, press **F8** when prompted to open the Cisco IMC Configuration Utility.

### Note

The first time that you enter the Cisco IMC Configuration Utility, you are prompted to change the default password. The default password is *password*. The Strong Password feature is enabled.

The following are the requirements for Strong Password:

- The password can have minimum 8 characters; maximum 14 characters.
- The password must not contain the user's name.
- The password must contain characters from three of the following four categories:
  - English uppercase letters (A through Z)
  - English lowercase letters (a through z)
  - Base 10 digits (0 through 9)
  - Non-alphabetic characters !, @, #, \$, %, ^, &, \*, -, \_, =, “

- Step 4** Continue with [Setting Up the System With the Cisco IMC Configuration Utility, on page 22](#).
- 

## Connecting to the Server Remotely For Setup

This procedure requires the following equipment:

- One RJ-45 Ethernet cable that is connected to your management LAN.

## Before you begin



**Note** To configure the system remotely, you must have a DHCP server on the same network as the system. Your DHCP server must be preconfigured with the range of MAC addresses for this server node. The MAC address is printed on a label that is on the pull-out asset tag on the front panel. This server node has a range of six MAC addresses assigned to the Cisco IMC. The MAC address printed on the label is the beginning of the range of six contiguous MAC addresses.

## Procedure

**Step 1** Attach a power cord to each power supply in your server, and then attach each power cord to a grounded power outlet. Wait for approximately two minutes to let the server boot to standby power during the first bootup. You can verify system power status by looking at the system Power Status LED on the front panel. The system is in standby power mode when the LED is amber.

**Step 2** Plug your management Ethernet cable into the dedicated management port on the rear panel.

**Step 3** Allow your preconfigured DHCP server to assign an IP address to the server node.

**Step 4** Use the assigned IP address to access and log in to the Cisco IMC for the server node. Consult with your DHCP server administrator to determine the IP address.

**Note**

The default user name for the server is *admin*. The default password is *password*.

**Step 5** From the Cisco IMC Server Summary page, click **Launch KVM Console**. A separate KVM console window opens.

**Step 6** From the Cisco IMC Summary page, click **Power Cycle Server**. The system reboots.

**Step 7** Select the KVM console window.

**Note**

The KVM console window must be the active window for the following keyboard actions to work.

**Step 8** When prompted, press **F8** to enter the Cisco IMC Configuration Utility. This utility opens in the KVM console window.

**Note**

The first time that you enter the Cisco IMC Configuration Utility, you are prompted to change the default password. The default password is *password*. The Strong Password feature is enabled.

The following are the requirements for Strong Password:

- The password can have minimum 8 characters; maximum 14 characters.
- The password must not contain the user's name.
- The password must contain characters from three of the following four categories:
  - English uppercase letters (A through Z)
  - English lowercase letters (a through z)
  - Base 10 digits (0 through 9)
  - Non-alphabetic characters !, @, #, \$, %, ^, &, \*, -, \_, =, “

**Step 9** Continue with [Setting Up the System With the Cisco IMC Configuration Utility, on page 22](#).

---

## Setting Up the System With the Cisco IMC Configuration Utility

### Before you begin

The following procedure is performed after you connect to the system and open the Cisco IMC Configuration Utility.

### Procedure

---

**Step 1** Set the NIC mode to choose which ports to use to access Cisco IMC for server management:

- *Shared LOM EXT* (default)—This is the shared LOM extended mode, the factory-default setting. With this mode, the Shared LOM and Cisco Card interfaces are both enabled. You must select the default *Active-Active* NIC redundancy setting in the following step.

In this NIC mode, DHCP replies are returned to both the shared LOM ports and the Cisco card ports. If the system determines that the Cisco card connection is not getting its IP address from a Cisco UCS Manager system because the server is in standalone mode, further DHCP requests from the Cisco card are disabled. Use the Cisco Card NIC mode if you want to connect to Cisco IMC through a Cisco card in standalone mode.

- *Shared LOM*—The 1-Gb/10-Gb Ethernet ports are used to access Cisco IMC. You must select either the *Active-Active* or *Active-standby* NIC redundancy setting in the following step.
- *Dedicated*—The dedicated management port is used to access Cisco IMC. You must select the *None* NIC redundancy setting in the following step.
- *Cisco Card*—The ports on an installed Cisco UCS Virtual Interface Card (VIC) are used to access the Cisco IMC. You must select either the *Active-Active* or *Active-standby* NIC redundancy setting in the following step.

See also the required VIC Slot setting below.

- *VIC Slot*—Only if you use the Cisco Card NIC mode, you must select this setting to match where your VIC is installed. The choices are Riser1, Riser2, or Flex-LOM (the mLOM slot).
  - If you select Riser1, you must install the VIC in slot 1.
  - If you select Riser2, you must install the VIC in slot 2.
  - If you select Flex-LOM, you must install an mLOM-style VIC in the mLOM slot.

**Step 2** Set the NIC redundancy to your preference. This server has three possible NIC redundancy settings:

- *None*—The Ethernet ports operate independently and do not fail over if there is a problem. This setting can be used only with the Dedicated NIC mode.
- *Active-standby*—If an active Ethernet port fails, traffic fails over to a standby port. Shared LOM and Cisco Card modes can each use either Active-standby or Active-active settings.

- *Active-active* (default)—All Ethernet ports are utilized simultaneously. The Shared LOM EXT mode must use only this NIC redundancy setting. Shared LOM and Cisco Card modes can each use either Active-standby or Active-active settings.

**Step 3** Choose whether to enable DHCP for dynamic network settings, or to enter static network settings.

**Note**

Before you enable DHCP, you must preconfigure your DHCP server with the range of MAC addresses for this server. The MAC address is printed on a label on the rear of the server. This server has a range of six MAC addresses assigned to Cisco IMC. The MAC address printed on the label is the beginning of the range of six contiguous MAC addresses.

The *static* IPv4 and IPv6 settings include the following:

- The Cisco IMC IP address.  
For IPv6, valid values are 1 - 127.
- The gateway.  
For IPv6, if you do not know the gateway, you can set it as none by entering :: (two colons).
- The preferred DNS server address.  
For IPv6, you can set this as none by entering :: (two colons).

**Step 4** (Optional) Make VLAN settings.

**Step 5** Press **F1** to go to the second settings window, then continue with the next step.

From the second window, you can press **F2** to switch back to the first window.

**Step 6** (Optional) Set a hostname for the server.

**Step 7** (Optional) Enable dynamic DNS and set a dynamic DNS (DDNS) domain.

**Step 8** (Optional) If you check the Factory Default check box, the server reverts to the factory defaults.

**Step 9** (Optional) Set a default user password.

**Note**

The factory default username for the server is *admin*. The default password is *password*.

**Step 10** (Optional) Enable auto-negotiation of port settings or set the port speed and duplex mode manually.

**Note**

Auto-negotiation is applicable only when you use the Dedicated NIC mode. Auto-negotiation sets the port speed and duplex mode automatically based on the switch port to which the server is connected. If you disable auto-negotiation, you must set the port speed and duplex mode manually.

**Step 11** (Optional) Reset port profiles and the port name.

**Step 12** Press **F5** to refresh the settings that you made. You might have to wait about 45 seconds until the new settings appear and the message, “Network settings configured” is displayed before you reboot the server in the next step.

**Step 13** Press **F10** to save your settings and reboot the server.

**Note**

If you chose to enable DHCP, the dynamically assigned IP and MAC addresses are displayed on the console screen during bootup.

**What to do next**

Use a browser and the IP address of the Cisco IMC to connect to the Cisco IMC management interface. The IP address is based upon the settings that you made (either a static address or the address assigned by your DHCP server).



**Note** The factory default username for the server is *admin*. The default password is *password*.

To manage the server, see the *Cisco UCS C-Series Rack-Mount Server Configuration Guide* or the *Cisco UCS C-Series Rack-Mount Server CLI Configuration Guide* for instructions on using those interfaces for your Cisco IMC release. The links to the configuration guides are in the [Cisco UCS C-Series Documentation Roadmap](#).

## NIC Mode and NIC Redundancy Settings

**Table 1: Valid NIC Redundancy Settings For Each NIC Mode**

NIC Mode	Valid NIC Redundancy Settings
Shared LOM EXT	Active-active
Dedicated	None
Shared LOM	Active-active Active-standby
Cisco Card	Active-active Active-standby
Share OCP	Active-active Active-standby
Share OCP Extended	Active-active Active-standby

This server has the following NIC mode settings that you can choose from:

- *Shared LOM EXT*—This is the shared LOM extended mode, the factory-default setting. With this mode, the Shared LOM and Cisco Card interfaces are both enabled. You must select the default *Active-Active* NIC redundancy setting in the following step.

In this NIC mode, DHCP replies are returned to both the shared LOM ports and the Cisco card ports. If the system determines that the Cisco card connection is not getting its IP address from a Cisco UCS Manager system because the server is in standalone mode, further DHCP requests from the Cisco card are disabled. Use the Cisco Card NIC mode if you want to connect to Cisco IMC through a Cisco card in standalone mode.

- *Shared LOM*—The 1-Gb/10-Gb Ethernet ports are used to access Cisco IMC. You must select either the *Active-Active* or *Active-standby* NIC redundancy setting in the following step.

- *Dedicated*—The dedicated management port is used to access Cisco IMC. You must select the *None* NIC redundancy setting in the following step.
- *Cisco Card*—The ports on an installed Cisco UCS Virtual Interface Card (VIC) are used to access the Cisco IMC. You must select either the *Active-Active* or *Active-standby* NIC redundancy setting in the following step.  
See also the required VIC Slot setting below.
- *Shared OCP*—The OCP adapter card LOM ports are used to access Cisco IMC. You must select either the *Active-Active* or *Active-standby* NIC redundancy setting in the following step.
- *Shared OCP Extended*—In this NIC mode, DHCP replies are returned to both the OCP adapter card LOM ports and the Cisco virtual interface card (VIC) ports. If the system determines that the Cisco VIC connection is not getting its IP address from a Cisco UCS Manager system because the server is in standalone mode, further DHCP requests from the Cisco VIC are disabled.

**Default NIC Mode Setting:**

VIC slot options are as follows:



---

**Note** After resetting to factory default settings, the slot precedence is as follows:

1. mLOM
  2. Riser 1 - Slot 1
  3. Riser 3 - Slot 3
- 

This server has the following NIC redundancy settings that you can choose from:

- *None*—The Ethernet ports operate independently and do not fail over if there is a problem. This setting can be used only with the *Dedicated* NIC mode.
- *Active-standby*—If an active Ethernet port fails, traffic fails over to a standby port. *Shared LOM* and *Cisco Card* modes can each use either *Active-standby* or *Active-active* settings.
- *Active-active* (default)—All Ethernet ports are utilized simultaneously. The *Shared LOM EXT* mode must use only this NIC redundancy setting. *Shared LOM* and *Cisco Card* modes can each use either *Active-standby* or *Active-active* settings.

## Updating the BIOS and Cisco IMC Firmware



---

**Caution** When you upgrade the BIOS firmware, you must also upgrade the Cisco IMC firmware to the same version or the server does not boot. Do not power off the server until the BIOS and Cisco IMC firmware are matching or the server does not boot.

Cisco provides the *Cisco Host Upgrade Utility* to assist with simultaneously upgrading the BIOS, Cisco IMC, and other firmware to compatible levels.

---

The server uses firmware obtained from and certified by Cisco. Cisco provides release notes with each firmware image. There are several possible methods for updating the firmware:

- **Recommended method for firmware update:** Use the Cisco Host Upgrade Utility to simultaneously upgrade the Cisco IMC, BIOS, and component firmware to compatible levels.  
See the *Cisco Host Upgrade Utility Quick Reference Guide* for your firmware release at the documentation roadmap link below.
- You can upgrade the Cisco IMC and BIOS firmware by using the Cisco IMC GUI interface.  
See the *Cisco UCS C-Series Rack-Mount Server Configuration Guide*.
- You can upgrade the Cisco IMC and BIOS firmware by using the Cisco IMC CLI interface.  
See the *Cisco UCS C-Series Rack-Mount Server CLI Configuration Guide*.

For links to the documents listed above, see the [Cisco UCS C-Series Documentation Roadmap](#).

## Accessing the System BIOS

### Procedure

---

**Step 1** Enter the BIOS Setup Utility by pressing the **F2** key when prompted during bootup.

**Note**

The version and build of the current BIOS are displayed on the Main page of the utility.

**Step 2** Use the arrow keys to select the BIOS menu page.

**Step 3** Highlight the field to be modified by using the arrow keys.

**Step 4** Press **Enter** to select the field that you want to change, and then modify the value in the field.

**Step 5** Press the right arrow key until the Exit menu screen is displayed.

**Step 6** Follow the instructions on the Exit menu screen to save your changes and exit the setup utility (or press **F10**). You can exit without saving changes by pressing **Esc**.

---

## Smart Access Serial

This server supports the Smart Access Serial feature. This feature allows you to switch between host serial and Cisco IMC CLI.

- This feature has the following requirements:
  - A serial cable connection, which can use either the RJ-45 serial connector on the server rear panel, or a DB-9 connection when using the KVM cable (Cisco PID N20-BKVM) on the front-panel KVM console connector.
  - Console redirection must be enabled in the server BIOS.
  - Terminal type must be set to VT100+ or VTUFT8.

- Serial-over-LAN (SOL) must be disabled (SOL is disabled by default).
- To switch from host serial to Cisco IMC CLI, press **Esc+9**.  
You must enter your Cisco IMC credentials to authenticate the connection.
- To switch from Cisco IMC CLI to host serial, press **Esc+8**.



---

**Note** You cannot switch to Cisco IMC CLI if the serial-over-LAN (SOL) feature is enabled.

---

- After a session is created, it is shown in the CLI or web GUI by the name `serial`.

## Smart Access USB

This server supports the Smart Access USB feature. The board management controller (BMC) in this server can accept a USB mass storage device and access the data on it. This feature allows you to use the front-panel USB device as a medium to transfer data between the BMC and the user without need for network connectivity. This can be useful, for example, when remote BMC interfaces are not yet available, or are not accessible due to network misconfiguration.

- This feature has the following requirements:
  - The KVM cable (Cisco PID N20-BKVM) connected to the front panel KVM console connector.
  - A USB storage device connected to one of the USB 2.0 connectors on the KVM cable. The USB device must draw less than 500 mA to avoid disconnect by the current-protection circuit.



---

**Note** Any mouse or keyboard that is connected to the KVM cable is disconnected when you enable Smart Access USB.

---

- You can use USB 3.0-based devices, but they will operate at USB 2.0 speed.
- We recommend that the USB device have only one partition.
- The file system formats supported are: FAT16, FAT32, MSDOS, EXT2, EXT3, and EXT4. NTFS is not supported.
- The front-panel KVM connector has been designed to switch the USB port between Host OS and BMC.
- Smart Access USB can be enabled or disabled using any of the BMC user interfaces. For example, you can use the Cisco IMC Configuration Utility that is accessed by pressing **F8** when prompted during bootup.
  - Enabled: the front-panel USB device is connected to the BMC.
  - Disabled: the front-panel USB device is connected to the host.

- In a case where no management network is available to connect remotely to Cisco IMC, a Device Firmware Update (DFU) shell over serial cable can be used to generate and download technical support files to the USB device that is attached to front panel USB port.



## CHAPTER 3

# Maintaining the Server

---

- [Status LEDs and Buttons](#), on page 29
- [Preparing For Component Installation](#), on page 34
- [Removing and Replacing Components](#), on page 39
- [Replacing SAS/SATA Hard Drives or Solid State Drives](#), on page 42
- [Replacing a Front-Loading NVMe SSD](#), on page 44
- [Replacing Fan Modules](#), on page 47
- [Replacing CPUs and Heatsinks](#), on page 47
- [Replacing RAID Cards](#), on page 55
- [Replacing Memory DIMMs](#), on page 59
- [Replacing the RTC Battery](#), on page 62
- [Replacing Power Supplies](#), on page 63
- [Replacing a PCIe Riser](#), on page 68
- [Replacing NVMe Cable](#), on page 69
- [Replacing a PCIe Card](#), on page 72
- [Cisco VIC mLOM and OCP Card Replacement Considerations](#), on page 75
- [Replacing an mLOM Card](#), on page 76
- [Replacing a SAS Storage Controller Card \(RAID or HBA\)](#), on page 78
- [Replacing the Supercap \(RAID Backup\)](#), on page 80
- [Replacing a Boot-Optimized M.2 RAID Controller Module](#), on page 81
- [Replacing a Chassis Intrusion Switch](#), on page 84
- [Installing a Trusted Platform Module \(TPM\)](#), on page 86
- [Removing the PCB Assembly \(PCBA\)](#), on page 88
- [Service DIP Switch, Headers and Jumpers](#), on page 89

## Status LEDs and Buttons

This section contains information for interpreting front, rear, and internal LED states.

# Front-Panel LEDs

Figure 11: Front Panel LEDs

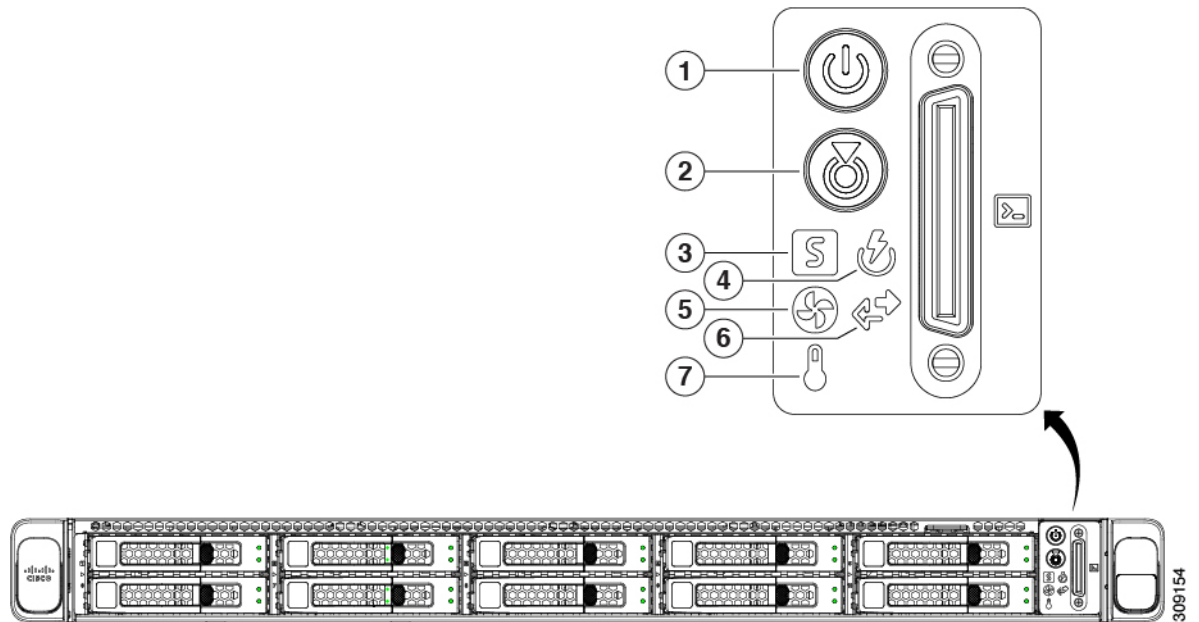









Table 2: Front Panel LEDs, Definition of States

	LED Name	States
1	Power button/LED (  )	<ul style="list-style-type: none"> <li>• Off—There is no AC power to the server.</li> <li>• Amber—The server is in standby power mode. Power is supplied only to the Cisco IMC and some motherboard functions.</li> <li>• Green—The server is in main power mode. Power is supplied to all server components.</li> </ul>
2	Unit identification (  )	<ul style="list-style-type: none"> <li>• Off—The unit identification function is not in use.</li> <li>• Blue, blinking—The unit identification function is activated.</li> </ul>

<p>3</p>	<p>System health ()</p>	<ul style="list-style-type: none"> <li>• Green—The server is running in normal operating condition.</li> <li>• Green, blinking—The server is performing system initialization and memory check.</li> <li>• Amber, steady—The server is in a degraded operational state (minor fault). For example:             <ul style="list-style-type: none"> <li>• Power supply redundancy is lost.</li> <li>• CPUs are mismatched.</li> <li>• At least one CPU is faulty.</li> <li>• At least one DIMM is faulty.</li> <li>• At least one drive in a RAID configuration failed.</li> </ul> </li> <li>• Amber, 2 blinks—There is a major fault with the system board.</li> <li>• Amber, 3 blinks—There is a major fault with the memory DIMMs.</li> <li>• Amber, 4 blinks—There is a major fault with the CPUs.</li> </ul>
<p>4</p>	<p>Power supply status ()</p>	<ul style="list-style-type: none"> <li>• Green—All power supplies are operating normally.</li> <li>• Amber, steady—One or more power supplies are in a degraded operational state.</li> <li>• Amber, blinking—One or more power supplies are in a critical fault state.</li> </ul>
<p>5</p>	<p>Fan status ()</p>	<ul style="list-style-type: none"> <li>• Green—All fan modules are operating properly.</li> <li>• Amber, blinking—One or more fan modules breached the non-recoverable threshold.</li> </ul>
<p>6</p>	<p>Network link activity ()</p>	<ul style="list-style-type: none"> <li>• Off—The Ethernet LOM port link is idle.</li> <li>• Green—One or more Ethernet LOM ports are link-active, but there is no activity.</li> <li>• Green, blinking—One or more Ethernet LOM ports are link-active, with activity.</li> </ul>
<p>7</p>	<p>Temperature status ()</p>	<ul style="list-style-type: none"> <li>• Green—The server is operating at normal temperature.</li> <li>• Amber, steady—One or more temperature sensors breached the critical threshold.</li> <li>• Amber, blinking—One or more temperature sensors breached the non-recoverable threshold.</li> </ul>

## Rear-Panel LEDs

Figure 12: Rear Panel LEDs

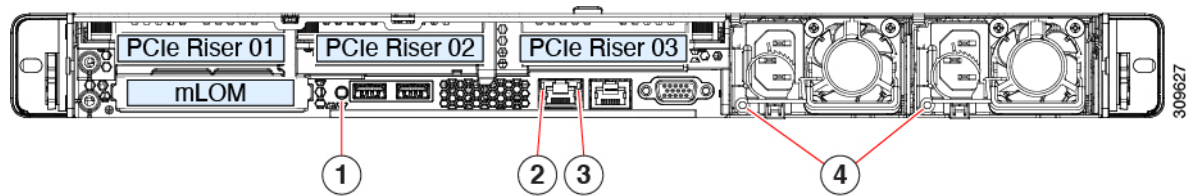

Table 3: Rear Panel LEDs, Definition of States

	LED Name	States
1	Rear unit identification	<ul style="list-style-type: none"> <li>• Off—The unit identification function is not in use.</li> <li>• Blue, blinking—The unit identification function is activated.</li> </ul>
2	1-Gb Ethernet dedicated management link speed	<ul style="list-style-type: none"> <li>• Off—Link speed is 10 Mbps.</li> <li>• Amber—Link speed is 100 Mbps.</li> <li>• Green—Link speed is 1 Gbps.</li> </ul>
3	1-Gb Ethernet dedicated management link status	<ul style="list-style-type: none"> <li>• Off—No link is present.</li> <li>• Green—Link is active.</li> <li>• Green, blinking—Traffic is present on the active link.</li> </ul>

4	Power supply status (one LED each power supply unit)	<p><b>AC power supplies:</b></p> <ul style="list-style-type: none"> <li>• Off—No AC input (12 V main power off, 12 V standby power off).</li> <li>• Green, blinking—12 V main power off; 12 V standby power on.</li> <li>• Green, solid—12 V main power on; 12 V standby power on.</li> <li>• Amber, blinking—Warning threshold detected but 12 V main power on.</li> <li>• Amber, solid—Critical error detected; 12 V main power off (for example, over-current, over-voltage, or over-temperature failure).</li> </ul> <p><b>DC power supplies:</b></p> <ul style="list-style-type: none"> <li>• Off—No DC input (12 V main power off, 12 V standby power off).</li> <li>• Green, blinking—12 V main power off; 12 V standby power on.</li> <li>• Green, solid—12 V main power on; 12 V standby power on.</li> <li>• Amber, blinking—Warning threshold detected but 12 V main power on.</li> <li>• Amber, solid—Critical error detected; 12 V main power off (for example, over-current, over-voltage, or over-temperature failure).</li> </ul>
---	--	---

## Internal Diagnostic LEDs

The server has internal fault LEDs for CPUs, DIMMs, and fan modules.

Figure 13: Internal Diagnostic LED Locations

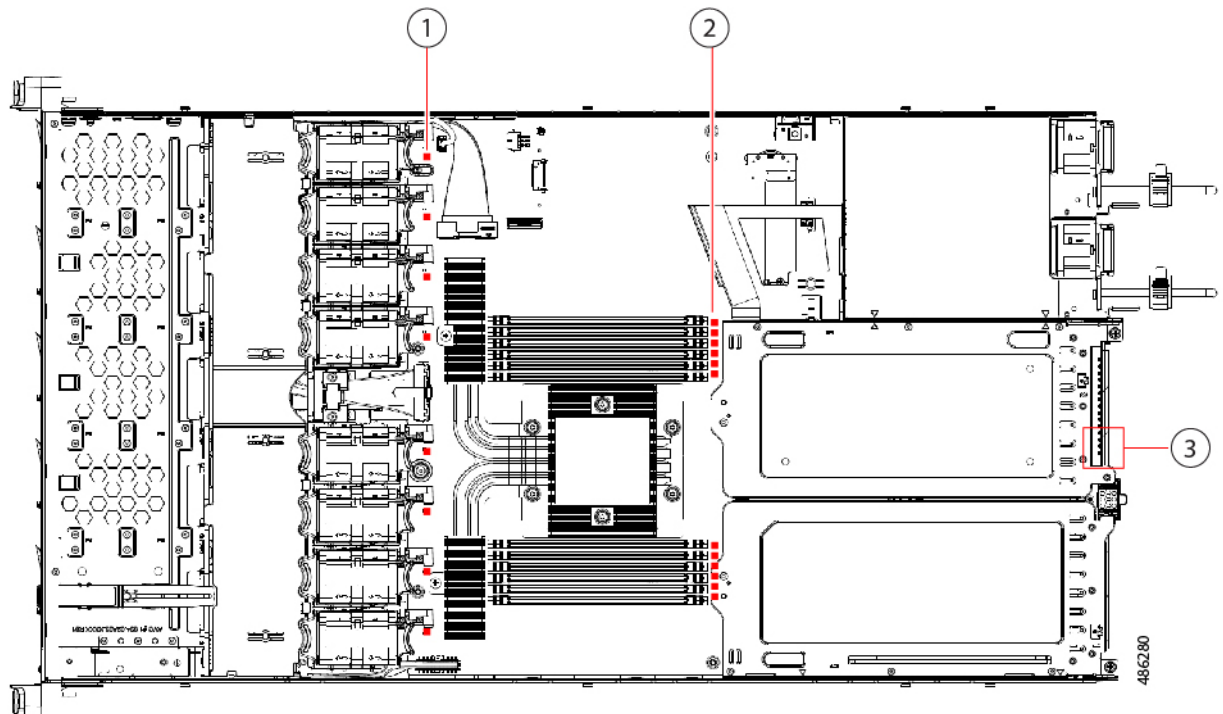

1	<p>Fan module fault LEDs (one behind each fan connector on the motherboard)</p> <ul style="list-style-type: none"> <li>• Amber—Fan has a fault or is not fully seated.</li> <li>• Green—Fan is OK.</li> </ul>	2	<p>DIMM fault LEDs (one behind each DIMM socket on the motherboard)</p> <p>These LEDs operate only when the server is in standby power mode.</p> <ul style="list-style-type: none"> <li>• Amber—DIMM has a fault.</li> <li>• Off—DIMM is OK.</li> </ul>
3	<p>CPU fault LEDs (beside rear USB2 connector).</p> <p>These LEDs operate only when the server is in standby power mode.</p> <ul style="list-style-type: none"> <li>• Amber—CPU has a fault.</li> <li>• Off—CPU is OK.</li> </ul>	-	

## Preparing For Component Installation

This section includes information and tasks that help prepare the server for component installation.

## Required Equipment For Service Procedures

The following tools and equipment are used to perform the procedures in this chapter:

- T-30 Torx driver (supplied with replacement CPUs for heatsink removal)
- #1 flat-head screwdriver (supplied with replacement CPUs for heatsink removal)
- #1 Phillips-head screwdriver (for M.2 SSD and intrusion switch replacement)
- Electrostatic discharge (ESD) strap or other grounding equipment such as a grounded mat

## Shutting Down and Removing Power From the Server

The server can run in either of two power modes:

- Main power mode—Power is supplied to all server components and any operating system on your drives can run.
- Standby power mode—Power is supplied only to the service processor and certain components. It is safe for the operating system and data to remove power cords from the server in this mode.



---

**Caution** After a server is shut down to standby power, electric current is still present in the server. To completely remove power as directed in some service procedures, you must disconnect all power cords from all power supplies in the server.

---

You can shut down the server by using the front-panel power button or the software management interfaces.

### Shutting Down Using the Power Button

#### Procedure

---

**Step 1** Check the color of the Power button/LED:

- Amber—The server is already in standby mode and you can safely remove power.
- Green—The server is in main power mode and must be shut down before you can safely remove power.

**Step 2** Invoke either a graceful shutdown or a hard shutdown:

**Caution**

To avoid data loss or damage to your operating system, you should always invoke a graceful shutdown of the operating system.

- Graceful shutdown—Press and release the **Power** button. The operating system performs a graceful shutdown and the server goes to standby mode, which is indicated by an amber Power button/LED.
- Emergency shutdown—Press and hold the **Power** button for 4 seconds to force the main power off and immediately enter standby mode.

- Step 3** If a service procedure instructs you to completely remove power from the server, disconnect all power cords from the power supplies in the server.
- 

## Shutting Down Using The Cisco IMC CLI

You must log in with user or admin privileges to perform this task.

### Procedure

---

- Step 1** At the server prompt, enter:

**Example:**

```
server# scope chassis
```

- Step 2** At the chassis prompt, enter:

**Example:**

```
server/chassis# power shutdown
```

The operating system performs a graceful shutdown and the server goes to standby mode, which is indicated by an amber Power button/LED.

- Step 3** If a service procedure instructs you to completely remove power from the server, disconnect all power cords from the power supplies in the server.
- 

## Shutting Down Using The Cisco IMC GUI

You must log in with user or admin privileges to perform this task.

### Procedure

---

- Step 1** In the Navigation pane, click the **Server** tab.

- Step 2** On the Server tab, click **Summary**.

- Step 3** In the Actions area, click **Power Off Server**.

- Step 4** Click **OK**.

The operating system performs a graceful shutdown and the server goes to standby mode, which is indicated by an amber Power button/LED.

- Step 5** If a service procedure instructs you to completely remove power from the server, disconnect all power cords from the power supplies in the server.
-

## Removing the Server Top Cover

### Procedure

---

#### Step 1

Remove the top cover:

- a) If the cover latch is locked, slide the lock sideways to unlock it.  
When the latch is unlocked, the handle pops up so that you can grasp it.
- b) Lift on the end of the latch so that it pivots vertically to 90 degrees.
- c) Simultaneously, slide the cover back and lift the top cover straight up from the server and set it aside.

#### Step 2

Replace the top cover:

- a) With the latch in the fully open position, place the cover on top of the server a few inches behind the lip of the front cover panel.
- b) Slide the cover forward until the latch makes contact.
- c) Press the latch down to the closed position. The cover is pushed forward to the closed position as you push down the latch.
- d) Lock the latch by sliding the lock button to sideways to the left.

Locking the latch ensures that the server latch handle does not protrude when you install the blade.

Figure 14: Removing the Top Cover

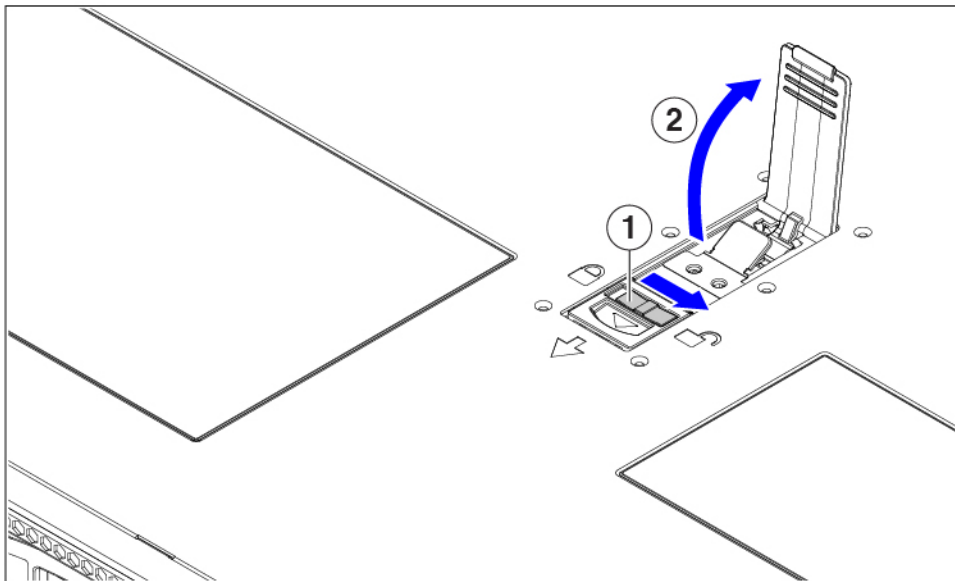
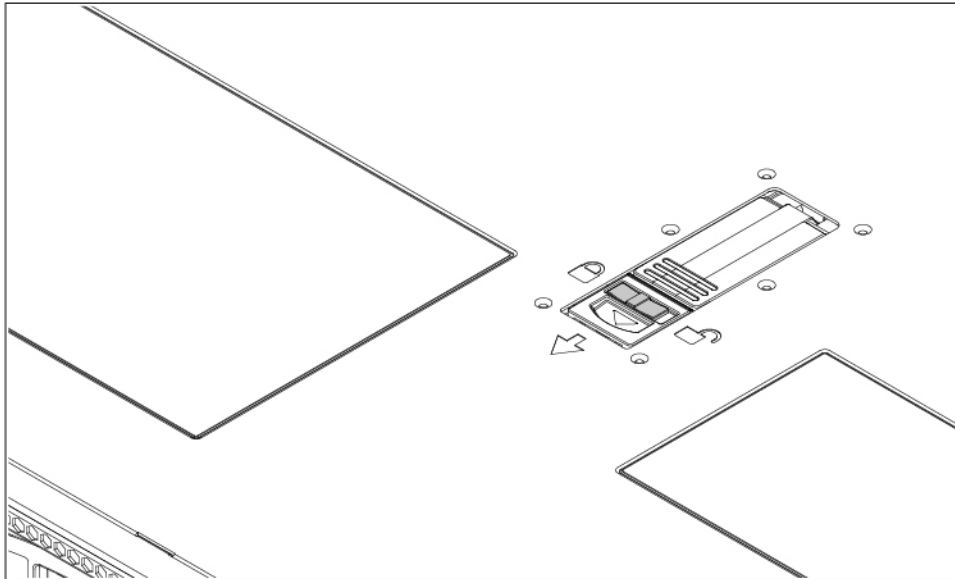

309157

1	Cover lock	2	Cover latch handle
---	------------	---	--------------------

## Hot Swap vs Hot Plug

Some components can be removed and replaced without shutting down and removing power from the server. This type of replacement has two varieties: hot-swap and hot-plug.

- Hot-swap replacement—You do not have to shut down the component in the software or operating system. This applies to the following components:
  - SAS/SATA hard drives
  - SAS/SATA solid state drives
  - Cooling fan modules
  - Power supplies (when redundant as 1+1)
- Hot-plug replacement—You must take the component offline before removing it for the following component:
  - NVMe PCIe solid state drives

## Removing and Replacing Components



### Warning

**Blank faceplates and cover panels serve three important functions: they prevent exposure to hazardous voltages and currents inside the chassis; they contain electromagnetic interference (EMI) that might disrupt other equipment; and they direct the flow of cooling air through the chassis. Do not operate the system unless all cards, faceplates, front covers, and rear covers are in place.**

Statement 1029



### Caution

When handling server components, handle them only by carrier edges and use an electrostatic discharge (ESD) wrist-strap or other grounding device to avoid damage.



### Tip

You can press the unit identification button on the front panel or rear panel to turn on a flashing, blue unit identification LED on both the front and rear panels of the server. This button allows you to locate the specific server that you are servicing when you go to the opposite side of the rack. You can also activate these LEDs remotely by using the Cisco IMC interface.

This section describes how to install and replace server components.

## Component Location

This topic shows the locations of the field-replaceable components and service-related items. The view in the following figure shows the server with the top cover removed.

Figure 15: Cisco UCS C225 M8 Server, Two Riser Configuration Serviceable Component Locations

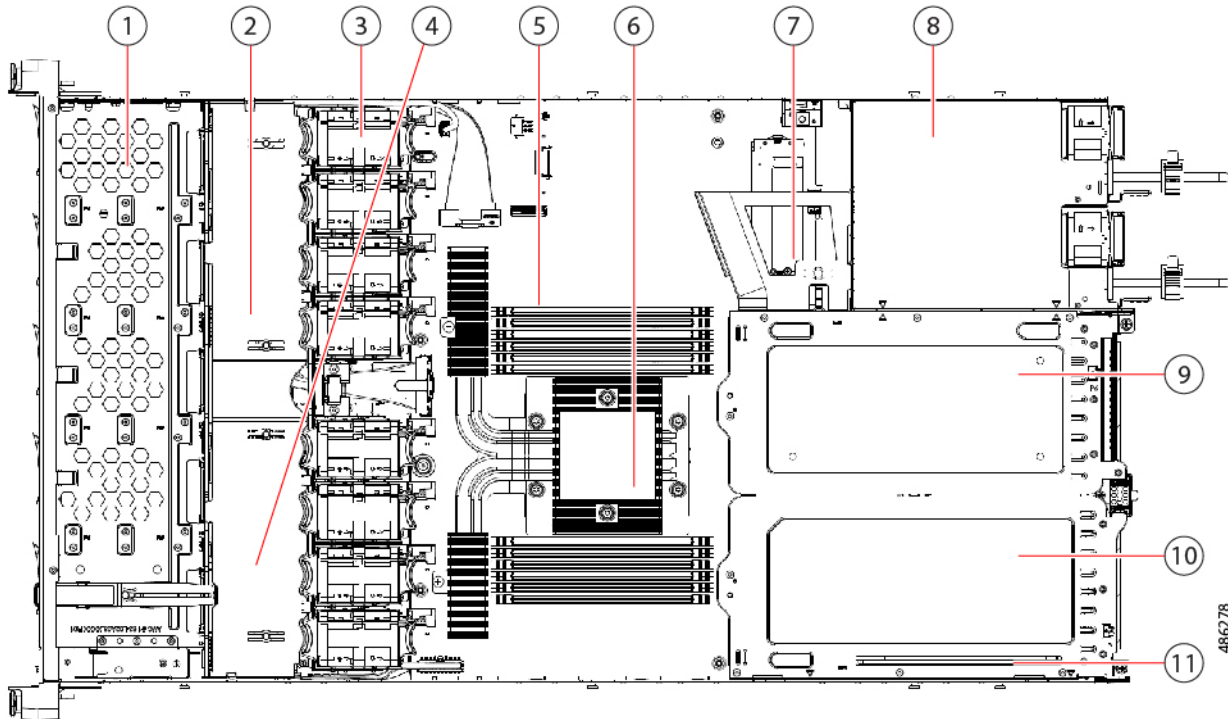

1	Front-loading drive bays 1–10 support SAS/SATA/NVMe drives.	2	Cisco 24G Tri-mode RAID controller
3	Cooling fan modules, eight. Each fan is hot-swappable	4	SuperCap module mounting bracket The SuperCap module (not shown) that mounts into this location provides RAID write-cache backup.
5	DIMM sockets on motherboard, 12 total.	6	Motherboard CPU socket
7	M.2 module connector Supports a boot-optimized RAID controller with connectors for up to two SATA M.2 SSDs	8	Power Supply Units (PSUs), two
9	PCIe riser slot 2	10	PCIe riser slot 1
11	Modular LOM (mLOM) card bay on chassis floor (x16 PCIe lane)		

Figure 16: Cisco UCS C225 M8 Server Three Riser Configuration Serviceable Component Locations

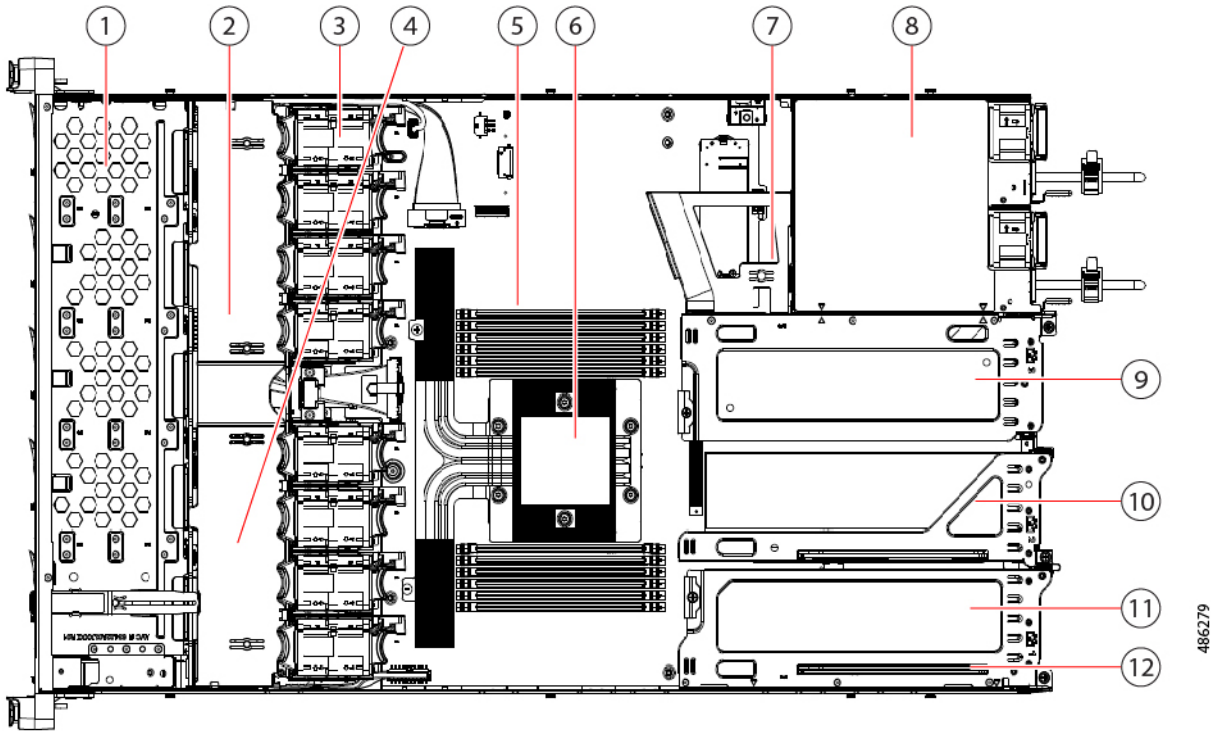

1	Front-loading drive bays 1–10 support SAS/SATA/NVMe drives.	2	Cisco M8 24G SAS RAID card or Cisco M8 24G SAS HBA Controller
3	Cooling fan modules, eight. Each fan is hot-swappable	4	SuperCap module mounting bracket The SuperCap module (not shown) that mounts into this location provides RAID write-cache backup.
5	DIMM sockets on motherboard, 12 total.	6	Motherboard CPU socket
7	M.2 module connector Supports a boot-optimized RAID controller with connectors for up to two SATA M.2 SSDs	8	Power Supply Units (PSUs), two
9	PCIe riser slot 3	10	PCIe riser slot 2
11	PCIe riser slot 1	12	Modular LOM (mLOM) card bay on chassis floor (x16 PCIe lane)

# Replacing SAS/SATA Hard Drives or Solid State Drives



**Note** You do not have to shut down the server or drive to replace SAS/SATA hard drives or SSDs because they are hot-swappable. To replace an NVMe PCIe SSD drive, which must be shut down before removal, see [Replacing a Front-Loading NVMe SSD, on page 44](#).

## SAS/SATA Drive Population Guidelines

The server is orderable in two different versions, each with a different front panel/drive-backplane configuration.

- Cisco UCS C225 M8 SAS/SATA (UCSC-C225-M8S)—Small form-factor (SFF) drives, with 10-drive backplane. Supports up to 10 2.5-inch SAS/SATA drives.

Drive bay numbering is shown in the following figures.

**Figure 17: Drive Bay Numbering**

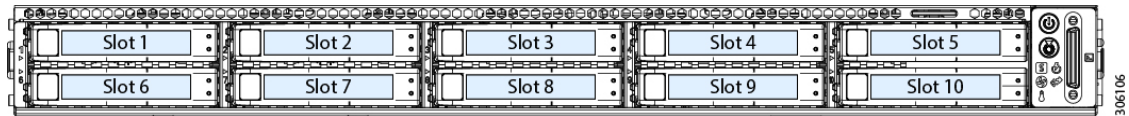

Observe these drive population guidelines for optimum performance:

- When populating drives, add drives to the lowest-numbered bays first.
- Keep an empty drive blanking tray in any unused bays to ensure proper airflow.
- You can mix SAS/SATA hard drives and SAS/SATA SSDs in the same server. However, you cannot configure a logical volume (virtual drive) that contains a mix of hard drives and SSDs. That is, when you create a logical volume, it must contain all SAS/SATA hard drives or all SAS/SATA SSDs.

## 4K Sector Format SAS/SATA Drives Considerations

- You must boot 4K sector format drives in UEFI mode, not legacy mode. UEFI mode is the system default. Only if the mode has been changed and must be changed back to UEFI mode, see the following procedure.
- Do not configure 4K sector format and 512-byte sector format drives as part of the same RAID volume.
- For operating system support on 4K sector drives, see the interoperability matrix tool for your server: [Hardware and Software Interoperability Matrix Tools](#)

### Procedure



## Replacing a SAS/SATA Drive

### Procedure

- Step 1** Remove the drive that you are replacing or remove a blank drive tray from the bay:
- Press the release button on the face of the drive tray.
  - Grasp and open the ejector lever and then pull the drive tray out of the slot.
  - If you are replacing an existing drive, remove the four drive-tray screws that secure the drive to the tray and then lift the drive out of the tray.
- Step 2** Install a new drive:
- Place a new drive in the empty drive tray and install the four drive-tray screws.
  - With the ejector lever on the drive tray open, insert the drive tray into the empty drive bay.
  - Push the tray into the slot until it touches the backplane, and then close the ejector lever to lock the drive in place.

**Figure 18: Replacing a Drive in a Drive Tray**

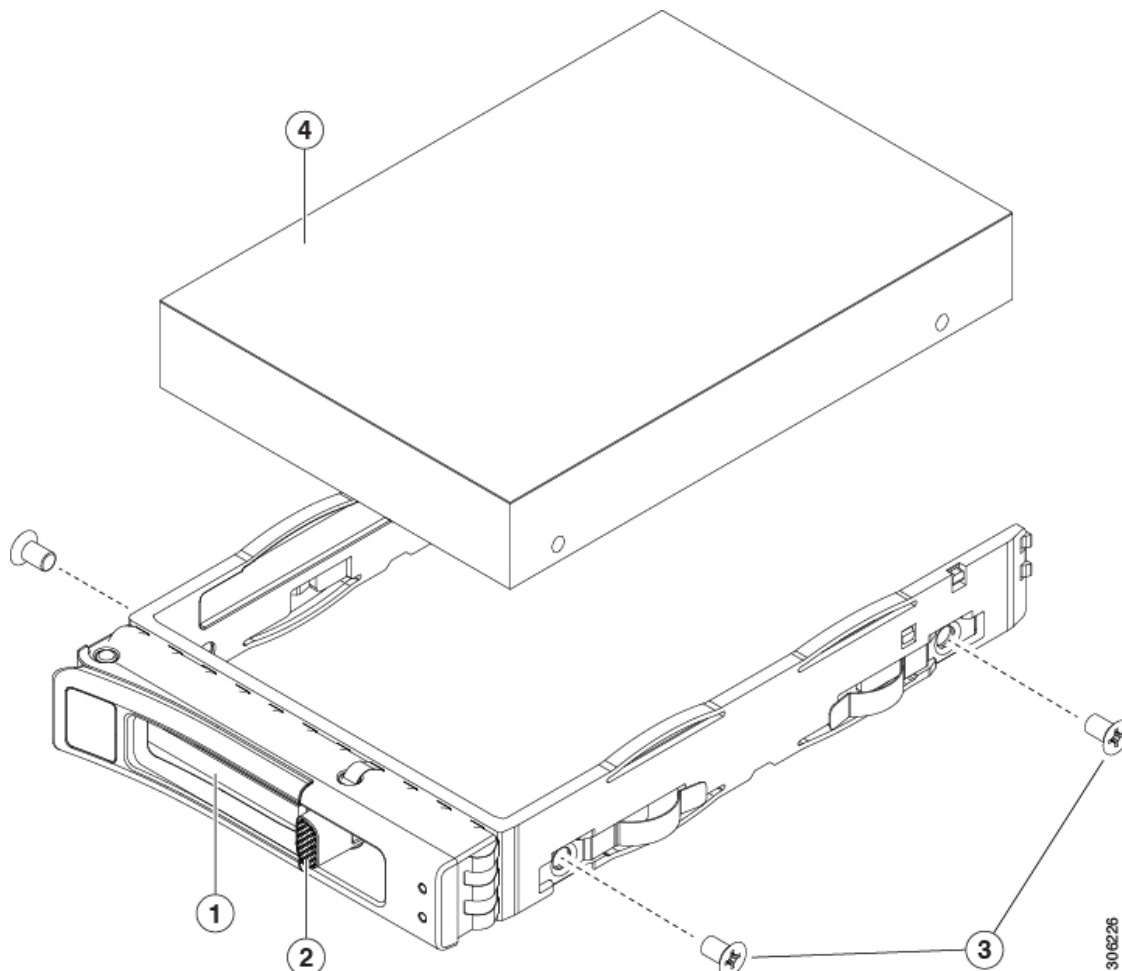

1	Ejector lever	3	Drive tray screws (two on each side)
---	---------------	---	--------------------------------------

2	Release button	4	Drive removed from drive tray
---	----------------	---	-------------------------------

## Replacing a Front-Loading NVMe SSD

This section is for replacing 2.5-inch form-factor NVMe solid-state drives (SSDs) in front-panel drive bays.

### Front-Loading NVMe SSD Population Guidelines

The server supports the following front drive bay configurations with 2.5 inch NVMe SSDs:

- Cisco UCS C225 M8 SAS/SATA (UCSC-C225-M8S)—Optional, front-loading drive bays 1 to 4 support 2.5-inch NVMe SSDs (with optional front NVMe cables).
- Cisco UCS C225 M8 NVMe (UCSC-C225-M8N)—10-drive backplane. Supports up to 10 2.5-inch NVMe-only SSDs.

*Figure 19: Drive Bay Numbering*

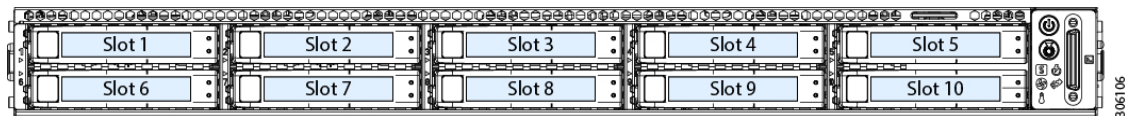

### Front-Loading NVMe SSD Requirements and Restrictions

Observe these requirements:

- Hot-plug support must be enabled in the system BIOS. If you ordered the system with NVMe drives, hot-plug support is enabled at the factory.
- The NVMe-optimized, SFF 10-drive version, supports NVMe drives only.

Observe these restrictions:

- NVMe SFF 2.5-inch SSDs support booting only in UEFI mode. Legacy boot is not supported. For instructions on setting up UEFI boot, see [4K Sector Format SAS/SATA Drives Considerations, on page 42](#).
- You cannot control NVMe PCIe SSDs with a SAS RAID controller because NVMe SSDs interface with the server via the PCIe bus.
- UEFI boot is supported in all supported operating systems. Hot-insertion and hot-removal are supported in all supported operating systems except VMWare ESXi.

### Enabling Hot-Plug Support in the System BIOS

Hot-plug (OS-informed hot-insertion and hot-removal) is disabled in the system BIOS by default.

- If the system was ordered with NVMe PCIe SSDs, the setting was enabled at the factory. No action is required.
- If you are adding NVMe PCIe SSDs after-factory, you must enable hot-plug support in the BIOS. See the following procedures.

## Enabling Hot-Plug Support Using the BIOS Setup Utility

### Procedure

- 
- Step 1** Enter the BIOS setup utility by pressing the **F2** key when prompted during bootup.
- Step 2** Navigate to **Advanced > PCI Subsystem Settings > NVMe SSD Hot-Plug Support**.
- Step 3** Set the value to **Enabled**.
- Step 4** Save your changes and exit the utility.
- 

## Replacing a Front-Loading NVMe SSD

This topic describes how to replace 2.5-inch form-factor NVMe SSDs in the front-panel drive bays.



---

**Note** OS-surprise removal is not supported. OS-informed hot-insertion and hot-removal are supported on all supported operating systems except VMware ESXi.

---



---

**Note** OS-informed hot-insertion and hot-removal must be enabled in the system BIOS. See [Enabling Hot-Plug Support in the System BIOS, on page 44](#).

---

### Procedure

- 
- Step 1** Remove an existing front-loading NVMe SSD:
- a) Shut down the NVMe SSD to initiate an OS-informed removal. Use your operating system interface to shut down the drive, and then observe the drive-tray LED:
    - Green—The drive is in use and functioning properly. Do not remove.
    - Green, blinking—the driver is unloading following a shutdown command. Do not remove.
    - Off—The drive is not in use and can be safely removed.
  - b) Press the release button on the face of the drive tray.
  - c) Grasp and open the ejector lever and then pull the drive tray out of the slot.
  - d) Remove the four drive tray screws that secure the SSD to the tray and then lift the SSD out of the tray.

- Step 2** Install a new front-loading NVMe SSD:
- Place a new SSD in the empty drive tray and install the four drive-tray screws.
  - With the ejector lever on the drive tray open, insert the drive tray into the empty drive bay.
  - Push the tray into the slot until it touches the backplane, and then close the ejector lever to lock the drive in place.

- Step 3** Observe the drive-tray LED and wait until it returns to solid green before accessing the drive:
- Off—The drive is not in use.
  - Green, blinking—the driver is initializing following hot-plug insertion.
  - Green—The drive is in use and functioning properly.

Figure 20: Replacing a Drive in a Drive Tray

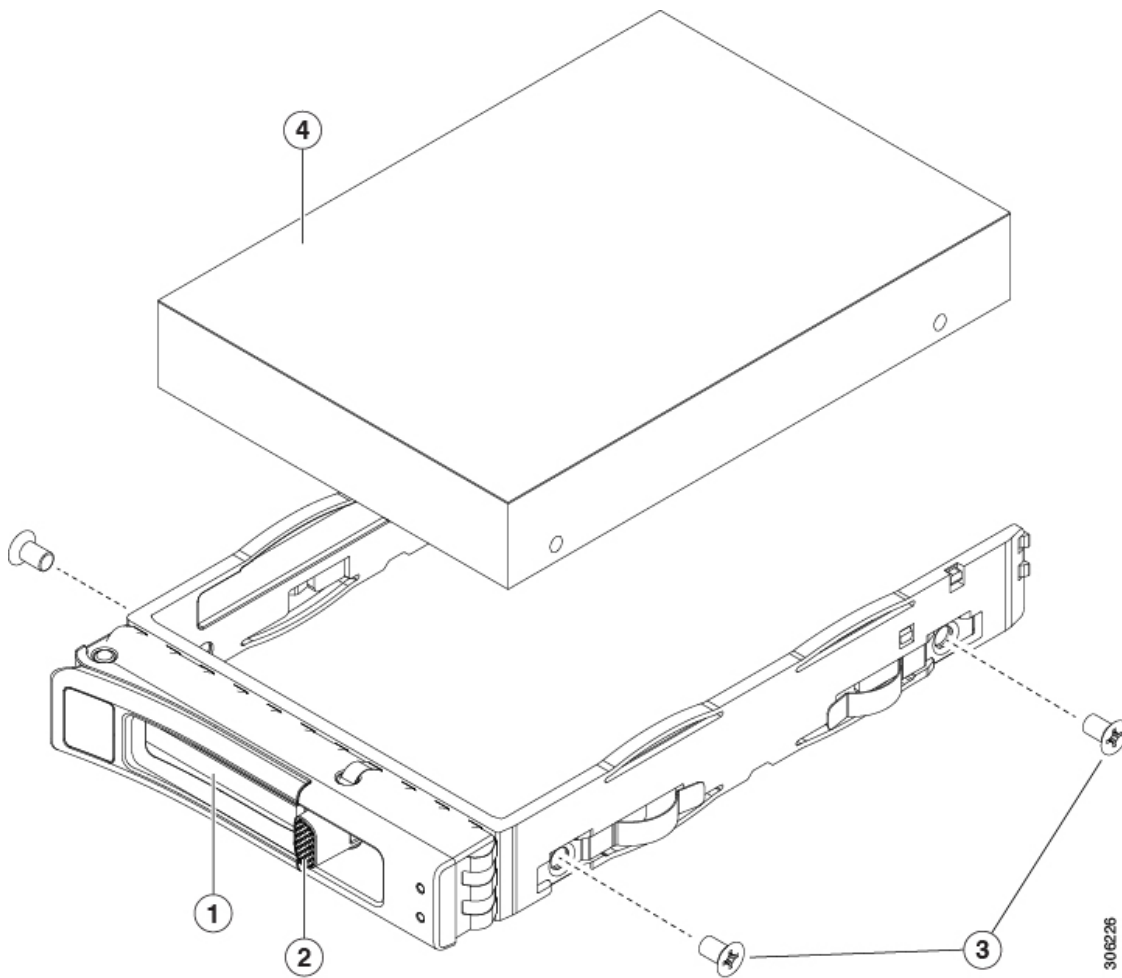

1	Ejector lever	3	Drive tray screws (two on each side)
2	Release button	4	Drive removed from drive tray

# Replacing Fan Modules

**Tip**

Each fan module has a fault LED next to the fan connector on the motherboard. This LED lights green when the fan is correctly seated and is operating OK. The LED lights amber when the fan has a fault or is not correctly seated.

**Caution**

You do not have to shut down or remove power from the server to replace fan modules because they are hot-swappable. However, to maintain proper cooling, do not operate the server for more than one minute with any fan module removed.

## Procedure

**Step 1**

Remove an existing fan module:

- a) Slide the server out the front of the rack far enough so that you can remove the top cover. You might have to detach cables from the rear panel to provide clearance.

**Caution**

If you cannot safely view and access the component, remove the server from the rack.

- b) Remove the top cover from the server as described in [Removing the Server Top Cover, on page 37](#).
- c) Grasp the fan module at its front and rear finger-grips. Lift straight up to disengage its connector from the motherboard.

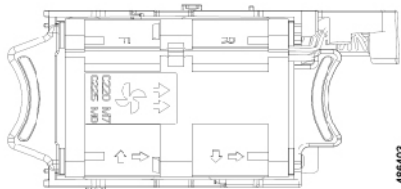
**Step 2**

Install a new fan module:

- a) Set the new fan module in place. The arrow printed on the top of the fan module should point toward the rear of the server.
- b) Press down gently on the fan module to fully engage it with the connector on the motherboard.
- c) Replace the top cover to the server.
- d) Replace the server in the rack, replace cables, and then fully power on the server by pressing the Power button.

# Replacing CPUs and Heatsinks

This section contains CPU configuration rules and the procedure for replacing CPUs and heatsinks:

## CPU Configuration Rules

This server has one CPU socket on the motherboard. CPU supports 12 DIMM slots. See [DIMM Population Rules and Memory Performance Guidelines](#), on page 60.

- The UCS C225 M8 server is a single CPU server. It operates with only one CPU installed.
- The maximum number of DIMMs is 12.

## Tools Required For CPU Replacement

You need the following tools and equipment for this procedure:

- T-20 Torx driver (for heatsink and CPU socket screws)
- Heatsink cleaning kit—Supplied with replacement CPU. Orderable separately as Cisco PID UCSX-HSCK=.  
One cleaning kit can clean up to four CPUs.
- Thermal interface material (TIM)—Syringe supplied with replacement CPU. Use only if you are reusing your existing heatsink (new heatsinks have a pre-applied pad of TIM). Orderable separately as Cisco PID UCS-CPU-TIM=.

One TIM kit covers one CPU.

See also [Additional CPU-Related Parts to Order with RMA Replacement CPUs](#), on page 55.

## Replacing a CPU and Heatsink

**Caution**

CPU and socket are fragile and must be handled with extreme care to avoid damaging pins. The CPU must be installed with heatsinks and thermal interface material to ensure cooling. Failure to install a CPU correctly might result in damage to the server.

### Procedure

**Step 1** Remove the existing CPU/heatsink assembly from the server:

- a) Shut down and remove power from the server as described in [Shutting Down and Removing Power From the Server](#), on page 35.
- b) Slide the server out the front of the rack far enough so that you can remove the top cover. You might have to detach cables from the rear panel to provide clearance.

**Caution**

If you cannot safely view and access the component, remove the server from the rack.

- c) Remove the top cover from the server as described in [Removing the Server Top Cover](#), on page 37.
- d) Use the T-20 Torx driver that is supplied with the replacement CPU to loosen the eight captive screws that secure the assembly to the motherboard standoff.

**Note**

Alternate loosening the heatsink screws evenly so that the heatsink remains level as it is raised.

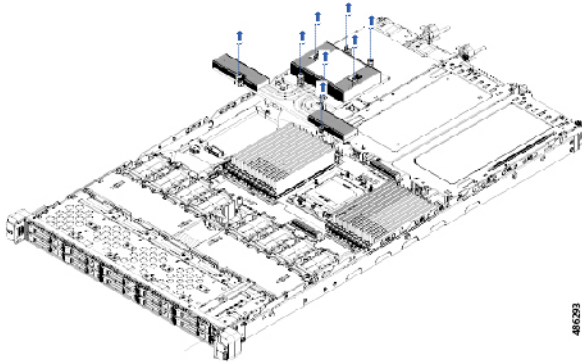

486293

- e) Loosen the screw that secures the CPU socket frame.

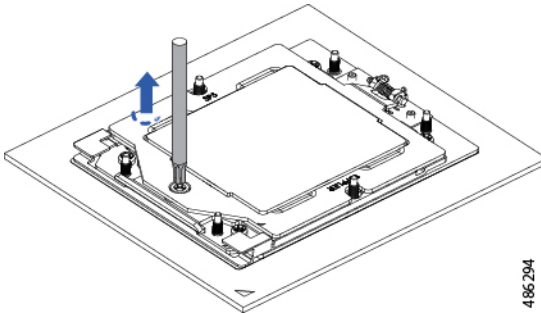

486294

- f) Carefully open the CPU socket frame to access the CPU.

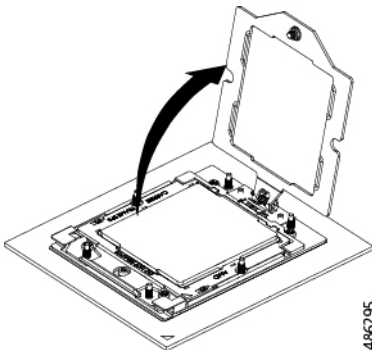

486295

- g) Open the rail frame that holds the CPU in place.

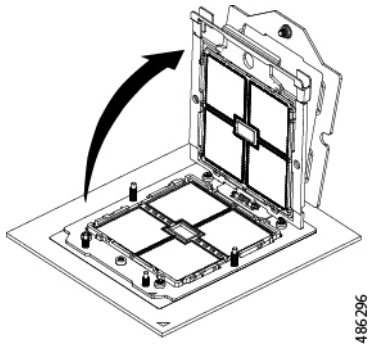

- h) Take out the CPU with carrier frame.

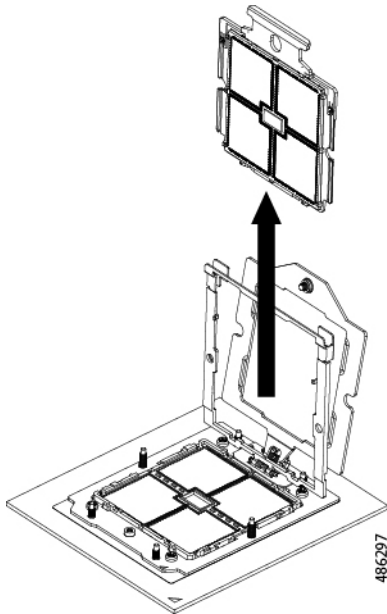

- i) (Optional) If you are not installing a new CPU immediately, place the dust cover and PNP cap over the empty CPU socket for protection.

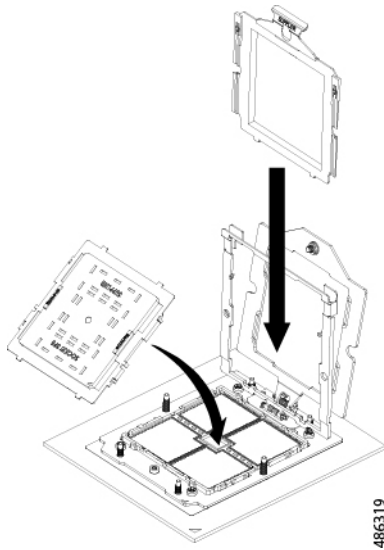

486319

**Step 2** Install the new CPU:

**Caution**

The CPU contacts and socket pins are extremely fragile. In this step, use extreme care to avoid touching or damaging the CPU contacts or the CPU socket pins.

- a) Open the CPU socket frame to prepare for the new CPU.

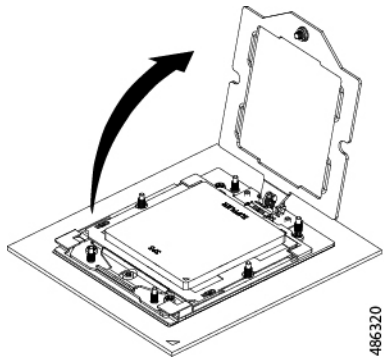

486320

- b) Open the rail frame to insert the new CPU.

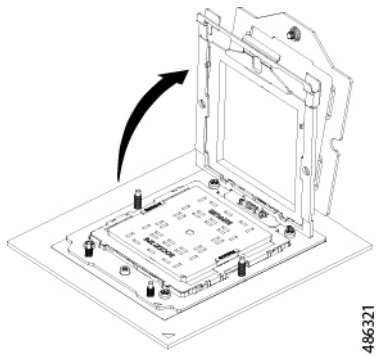

486321

- c) (Optional) Remove the dust cover and PNP cap from the socket (if present).

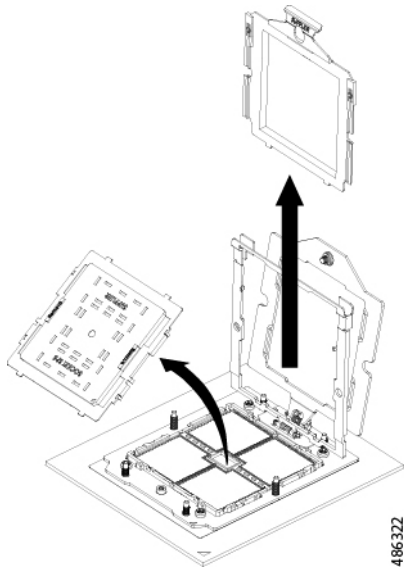

- d) Grasping the CPU only by the handling tab on its carrier frame, carefully slide it down into the open rail frame.

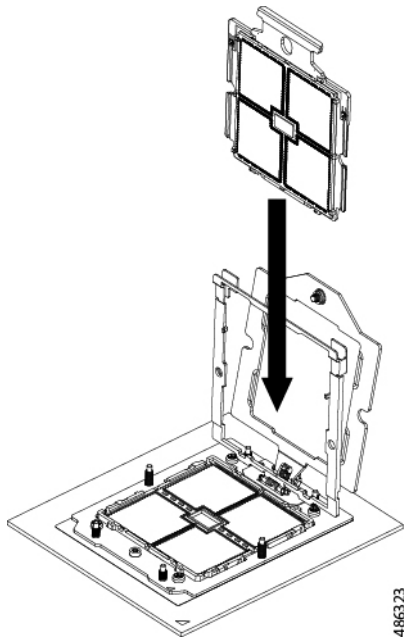

- e) Gently close the rail frame down to the flat, closed position.

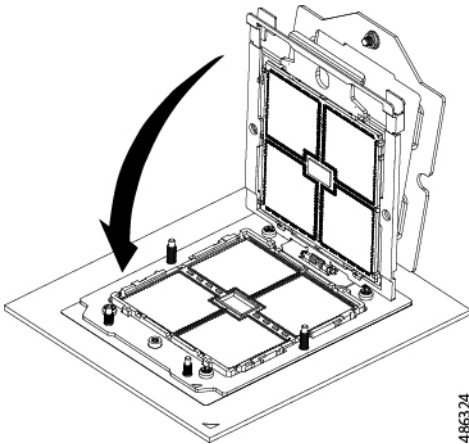

486324

- f) Gently close the socket frame down to the flat, closed position.

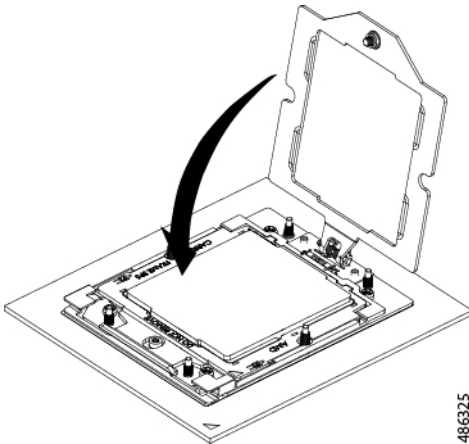

486325

- g) Tighten the three screw on the socket frame.

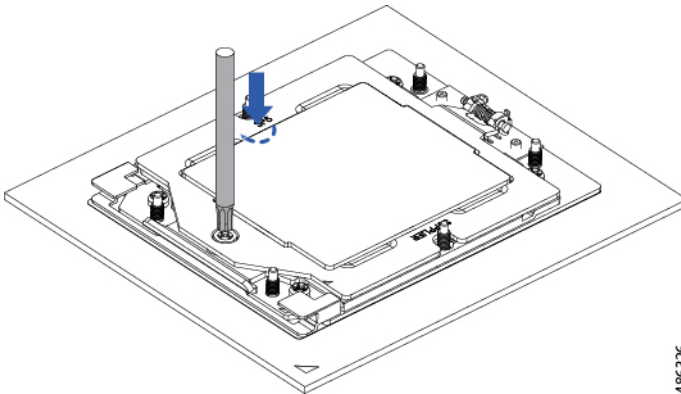

486326

**Step 3** Apply new TIM to the heatsink:

**Note**

The heatsink must have new TIM on the heatsink-to-CPU surface to ensure proper cooling and performance.

- If you are installing a new heatsink, it is shipped with a pre-applied pad of TIM. Go to step 5.

- If you are reusing a heatsink, you must remove the old TIM from the heatsink and then apply new TIM to the CPU surface from the supplied syringe. Continue with step a below.
- a) Apply the cleaning solution that is included with the heatsink cleaning kit (UCSX-HSCK=) to the old TIM on the heatsink and let it soak for a least 15 seconds.
- b) Wipe all of the TIM off the heatsink using the soft cloth that is included with the heatsink cleaning kit. Be careful to avoid scratching the heatsink surface.
- c) Using the syringe of TIM provided with the new CPU (UCS-CPU-TIM=), apply 4 cubic centimeters of thermal interface material to the top of the CPU. Use the pattern shown below to ensure even coverage.

**Figure 21: Thermal Interface Material Application Pattern**

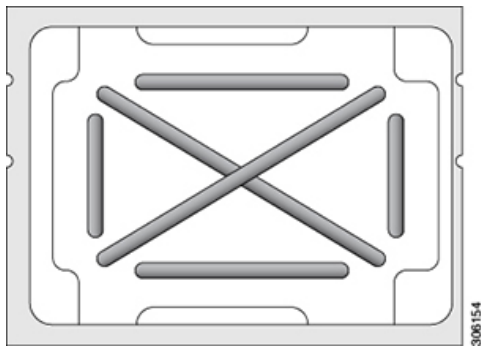

**Caution**

Use only the correct heatsink for your CPUs to ensure proper cooling.

**Step 4** Install the heatsink to the CPU:

- a) Align the heatsink over the CPU socket. Align the triangle-mark on the heatsink with the triangle-mark on the socket frame.
- b) Reattach the heatsink and tighten the screws to secure it.

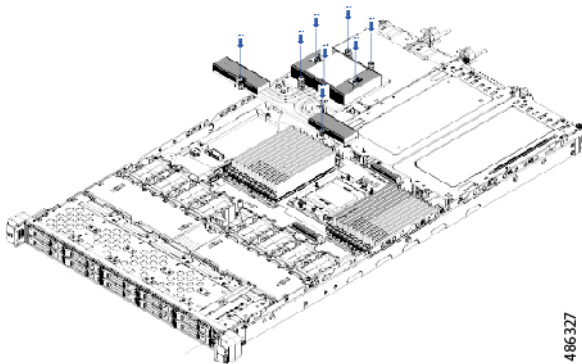

**Step 5** Reconnect any cables that you removed.

**Step 6** Power on the server.

## Additional CPU-Related Parts to Order with RMA Replacement CPUs

When a return material authorization (RMA) of the CPU is done on a Cisco UCS C-Series server, additional parts might not be included with the CPU spare. The TAC engineer might need to add the additional parts to the RMA to help ensure a successful replacement.



---

**Note** The following items apply to CPU *replacement* scenarios.

---

Scenario 1—You are reusing the existing heatsinks or moving CPUs and heatsinks to a new node:

- Heatsink cleaning kit (UCSX-HSCK=)  
One cleaning kit can clean up to four CPUs.
- Thermal interface material (TIM) kit (UCS-CPU-TIM=)  
One TIM kit covers one CPU.

Scenario 2—You are replacing the existing heatsinks:

- Heatsink: UCSC-HSHP-225M8=  
New heatsinks have a pre-applied pad of TIM.
- Heatsink cleaning kit (UCSX-HSCK=)  
One cleaning kit can clean up to four CPUs.

A CPU heatsink cleaning kit is good for up to four CPU and heatsink cleanings. The cleaning kit contains two bottles of solution, one to clean the CPU and heatsink of old TIM and the other to prepare the surface of the heatsink.

New heatsink spares come with a pre-applied pad of TIM. It is important to clean any old TIM off of the CPU surface prior to installing the heatsinks. Therefore, even when you are ordering new heatsinks, you must order the heatsink cleaning kit.

## Replacing RAID Cards

The RAID card is located in the front of the server. This process requires you to disconnect the RAID cables from the card and motherboard before removing the RAID card.

## Removing Cisco Trimode M1 24G RAID Controller W/4GB FBWC (16 Drives)

Use this procedure to replace a RAID card that has been removed or needs to be replaced.

### Procedure

---

- Step 1** Shut down and remove power from the server.
- Step 2** Slide the server out the front of the rack far enough to remove the top cover.

**Step 3** Remove the existing RAID card from the server.

**Note**

You must remove the old card from the card carrier bracket during replacement.

- a) Disconnect RAID card controller cables from the existing card.

*Figure 22: Disconnecting RAID card controller cables*

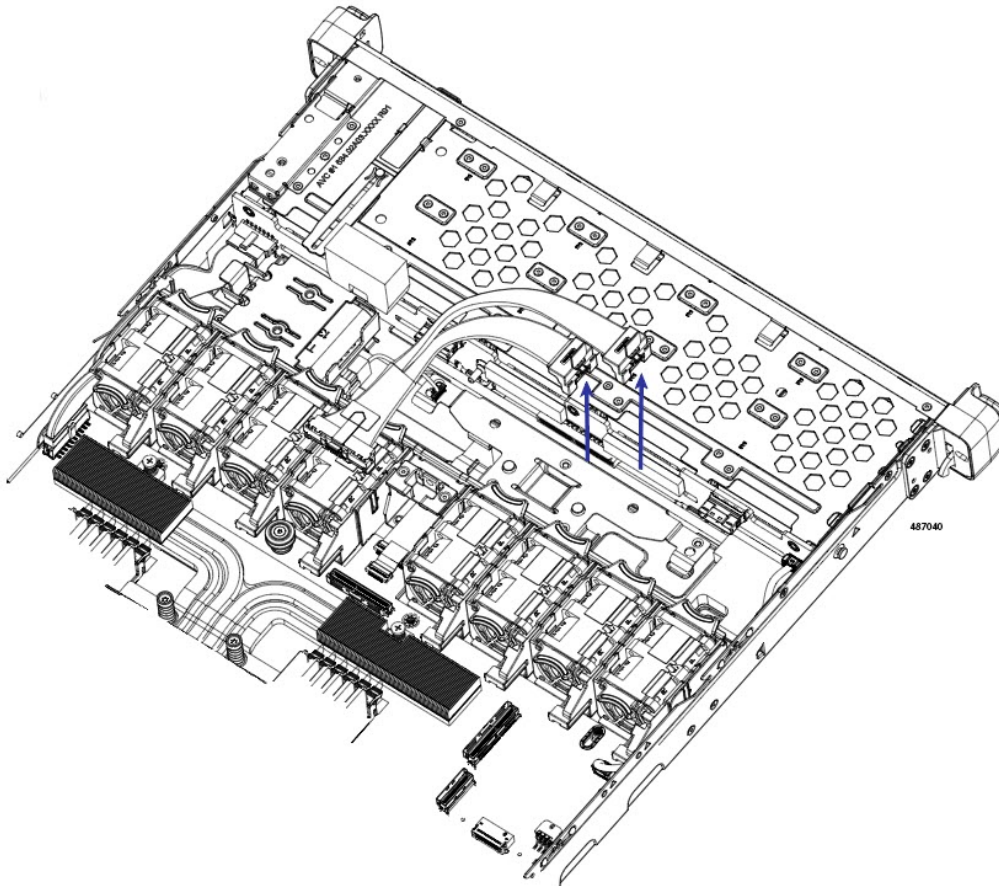

**Step 4** Lift the card's ejector lever to unseat it from the motherboard socket.

**Step 5** Lift straight up on the card's carrier frame to disengage the card from the motherboard socket.

- a) Use a #1 Phillips-head screwdriver to remove the screws that secure the RAID Card to the carrier and lift the card from the bracket.

Figure 23: Removing RAID card from carrier bracket

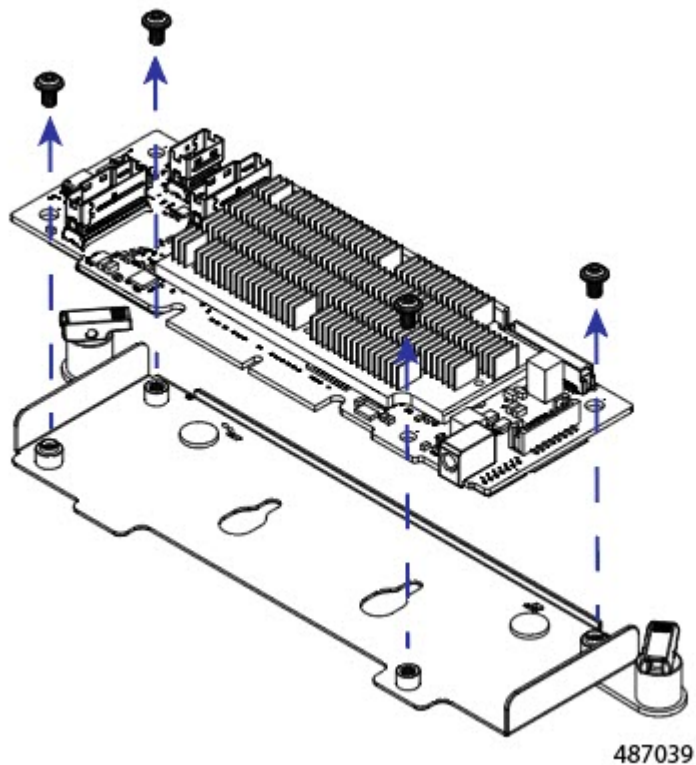

### What to do next

## Installing Cisco Trimode M1 24G RAID Controller W/4GB FBWC (16 Drives)

To install a RAID card, attach the new card to the mounting fixture and then attach the RAID card mounting fixture to the server motherboard.

### Procedure

- Step 1** Shut down and remove power from the server.
- Step 2** Slide the server out the front of the rack far enough to remove the top cover.
- Step 3** Install the replacement RAID Card.

#### Note

During installation, attach the new card to the mounting bracket before installing the RAID card to the server motherboard.

- a) Install the new RAID to its carrier bracket. Use a #1 Phillips-head screwdriver to attach the screws that secure the RAID Card to the carrier.

*Figure 24: Removing RAID card from carrier bracket*

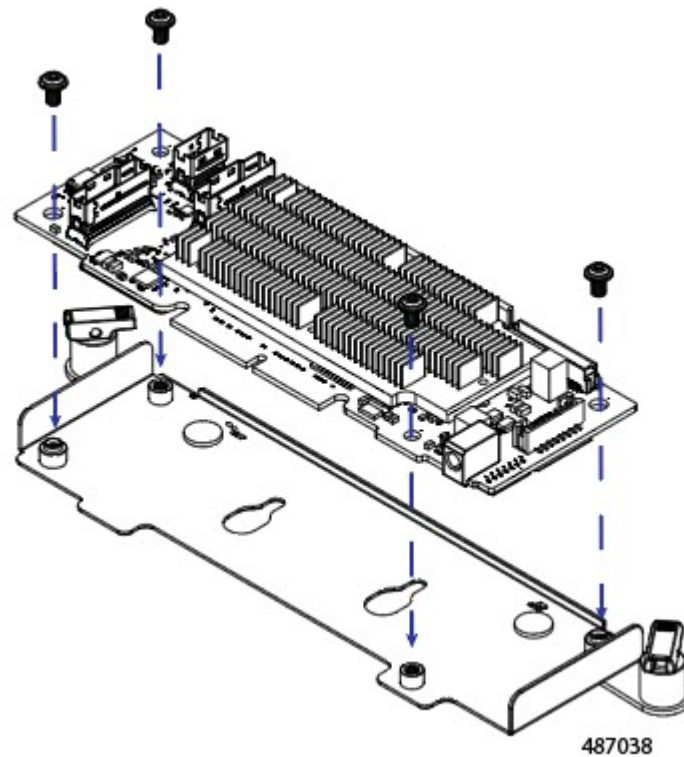

- b) Insert the RAID card carrier straight down on the motherboard socket.
- c) Secure the RAID card to the motherboard using the ejector levers.
- d) Connect the RAID card controller cables to the new RAID card.

Figure 25: Connecting RAID card controller cables

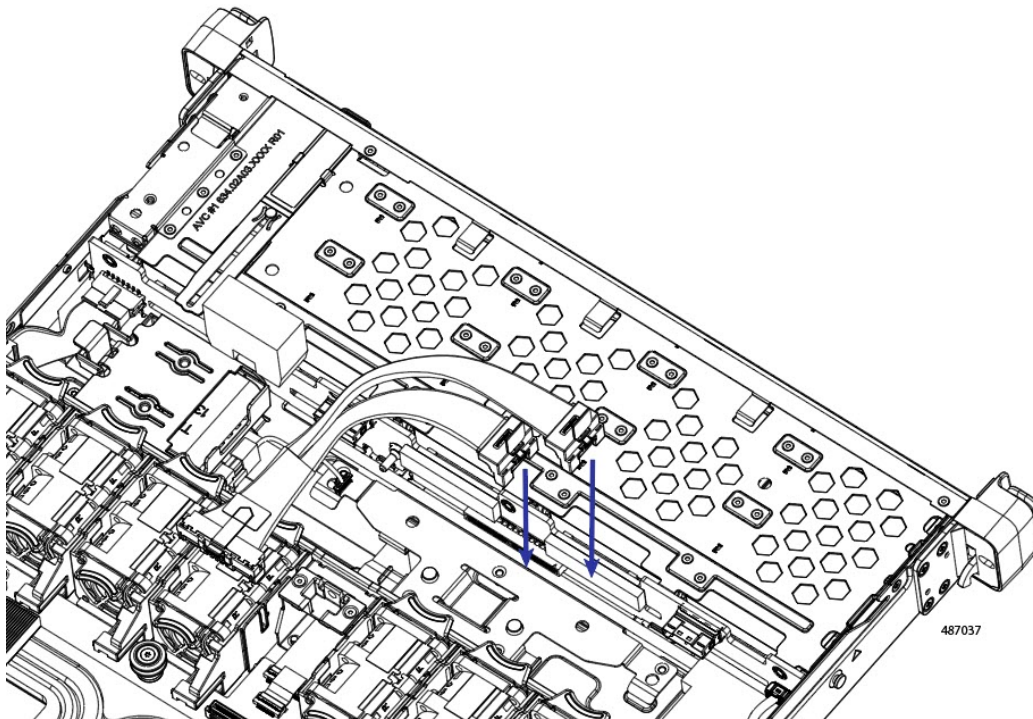

**Step 4** Replace the top cover of the server.

#### What to do next

## Replacing Memory DIMMs



**Caution** DIMMs and their sockets are fragile and must be handled with care to avoid damage during installation.



**Caution** Cisco does not support third-party DIMMs. Using non-Cisco DIMMs in the server might result in system problems or damage to the motherboard.



**Note** To ensure the best server performance, it is important that you are familiar with memory performance guidelines and population rules before you install or replace DIMMs.

# DIMM Population Rules and Memory Performance Guidelines

This topic describes the rules and guidelines for maximum memory performance.

## DIMM Population Rules

Observe the following guidelines when installing or replacing DIMMs on a server powered by 4th Gen. AMD and 5th Gen AMD EPYC™ CPUs:

- All memory DIMMs must be RDIMM (16GB, 32GB, 48GB, 64GB, and 96GB) or RDIMM 3DS (128GB) module types.
- All memory DIMMs must be Cisco DDR5-5600 memory PIDs, although the memory will operate at the maximum speed of the 4th Gen. AMD EPYC™ CPUs memory controller, up to 4800 MT/s. Cisco DDR5-6400 memory PIDs, although the memory will operate at the speed of the 5th Gen. AMD EPYC™ CPUs memory controller, up to 6000 MT/s.
- Balanced memory configurations maximize memory bandwidth by optimizing memory interleaving. To obtain a balanced memory configuration:
  - Populate each socket with 1, 2, 4, 6, 8, 10, or 12 memory channels.
  - Use the same memory configuration in all populated memory channels. No DIMM density mixing across channel is allowed.
  - No DIMM mixing within a channel is possible as server supports only 1DPC.
- Maximum memory capacity of 3 TB using 256 GB DIMMs.
- Memory mirroring reduces the amount of memory available by 50 percent because only one of the two populated channels provides data. When memory mirroring is enabled, you must install DIMMs in even numbers of channels.

## Memory Population Order

The following tables show the memory population order for each memory option.

**Table 4: DIMMs Population Order**

#DIMMs per CPU	DIMM Population - 16GB, 32GB, 48GB, 64GB, 128GB, 256GB
1	A1
2	A1, G1
4	A1, C1, G1, I1
6	A1, B1, C1, G1, H1, I1
8	A1, B1, C1, E1, G1, H1, I1, K1
10	A1, B1, C1, D1, E1, G1, H1, I1, J1, K1
12	A1, B1, C1, D1, E1, F1, G1, H1, I1, J1, K1, L1

### Memory Mirroring

The CPUs in the server support memory mirroring only when an even number of channels are populated with DIMMs. If one or three channels are populated with DIMMs, memory mirroring is automatically disabled.

Memory mirroring reduces the amount of memory available by 50 percent because only one of the two populated channels provides data. The second, duplicate channel provides redundancy.

## Replacing DIMMs

### Identifying a Faulty DIMM

Each DIMM socket has a corresponding DIMM fault LED, directly in front of the DIMM socket. See [Internal Diagnostic LEDs, on page 33](#) for the locations of these LEDs. When the server is in standby power mode, these LEDs light amber to indicate a faulty DIMM.

### Procedure

---

**Step 1** Remove an existing DIMM:

- a) Shut down and remove power from the server as described in [Shutting Down and Removing Power From the Server, on page 35](#).
- b) Slide the server out the front of the rack far enough so that you can remove the top cover. You might have to detach cables from the rear panel to provide clearance.

**Caution**

If you cannot safely view and access the component, remove the server from the rack.

- c) Remove the top cover from the server as described in [Removing the Server Top Cover, on page 37](#).
- d) Remove the air baffle that covers the front ends of the DIMM slots to provide clearance.
- e) Locate the DIMM that you are removing, and then open the ejector levers at each end of its DIMM slot.

**Step 2** Install a new DIMM:

**Note**

Before installing DIMMs, see the memory population rules for this server: [DIMM Population Rules and Memory Performance Guidelines, on page 60](#).

- a) Align the new DIMM with the empty slot on the motherboard. Use the alignment feature in the DIMM slot to correctly orient the DIMM.
  - b) Push down evenly on the top corners of the DIMM until it is fully seated and the ejector levers on both ends lock into place.
  - c) Replace the top cover to the server.
  - d) Replace the server in the rack, replace cables, and then fully power on the server by pressing the Power button.
-

# Replacing the RTC Battery



**Warning** There is danger of explosion if the battery is replaced incorrectly. Replace the battery only with the same or equivalent type recommended by the manufacturer. Dispose of used batteries according to the manufacturer's instructions.

[Statement 1015]



**Warning Recyclers:** Do not shred the battery! Make sure you dispose of the battery according to appropriate regulations for your country or locale.

The real-time clock (RTC) battery retains system settings when the server is disconnected from power. The battery type is CR2032. Cisco supports the industry-standard CR2032 battery, which can be ordered from Cisco (PID N20-MBLIBATT) or purchased from most electronic stores.

## Procedure

**Step 1** Remove the RTC battery:

- a) Shut down and remove power from the server as described in [Shutting Down and Removing Power From the Server, on page 35](#).
- b) Slide the server out the front of the rack far enough so that you can remove the top cover. You might have to detach cables from the rear panel to provide clearance.

**Caution**

If you cannot safely view and access the component, remove the server from the rack.

- c) Remove the top cover from the server as described in [Removing the Server Top Cover, on page 37](#).
- d) Locate the RTC battery. The vertical socket is directly in front of PCIe riser 2.
- e) Remove the battery from the socket on the motherboard. Gently pry the securing clip on one side open to provide clearance, then lift straight up on the battery.

**Step 2** Install a new RTC battery:

- a) Insert the battery into its holder and press down until it clicks in place under the clip.

**Note**

The flat, positive side of the battery marked “3V+” should face left as you face the server front.

- b) Replace the top cover to the server.
- c) Replace the server in the rack, replace cables, and then fully power on the server by pressing the Power button.

Figure 26: RTC Battery Location on Motherboard

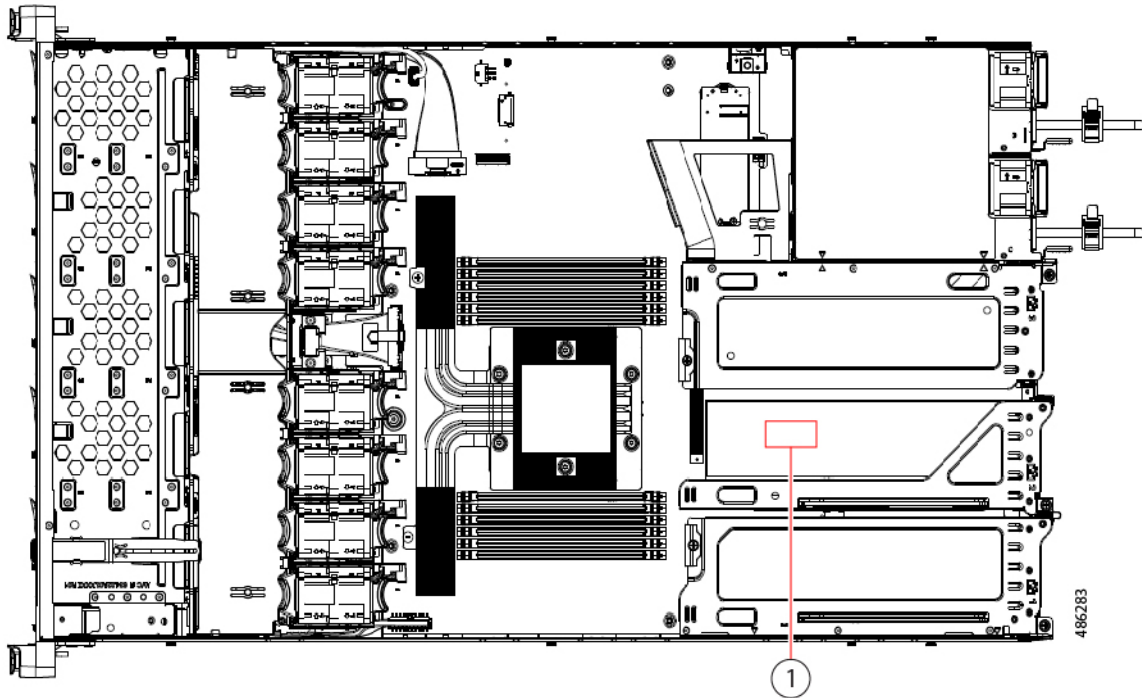

1	RTC battery in vertical socket	-	
---	--------------------------------	---	--

## Replacing Power Supplies

The server can have one or two Titanium 80PLUS rated power supplies. When two power supplies are installed they are redundant as 1+1 by default.

- See also [Power Specifications](#), on page 105 for more information about the power supplies.
- See also [Rear-Panel LEDs](#), on page 32 for information about the power supply LEDs.

This section includes procedures for replacing AC and DC power supply units.

- [Replacing AC Power Supplies](#), on page 64
- [Replacing DC Power Supplies](#), on page 65
- [Installing DC Power Supplies \(First Time Installation\)](#), on page 66
- [Grounding for DC Power Supplies](#), on page 68

# Replacing AC Power Supplies



**Note** If you have ordered a server with power supply redundancy (two power supplies), you do not have to power off the server to replace a power supply because they are redundant as 1+1.



**Note** Do not mix power supply types or wattages in the server. Both power supplies must be identical.

## Procedure

- Step 1** Remove the power supply that you are replacing or a blank panel from an empty bay:
- a) Perform one of the following actions:
    - If your server has only one power supply, shut down and remove power from the server as described in [Shutting Down and Removing Power From the Server, on page 35](#).
    - If your server has two power supplies, you do not have to shut down the server.
  - b) Remove the power cord from the power supply that you are replacing.
  - c) Grasp the power supply handle while pinching the release lever toward the handle.
  - d) Pull the power supply out of the bay.
- Step 2** Install a new power supply:
- a) Grasp the power supply handle and insert the new power supply into the empty bay.
  - b) Push the power supply into the bay until the release lever locks.
  - c) Connect the power cord to the new power supply.
  - d) Only if you shut down the server, press the Power button to boot the server to main power mode.

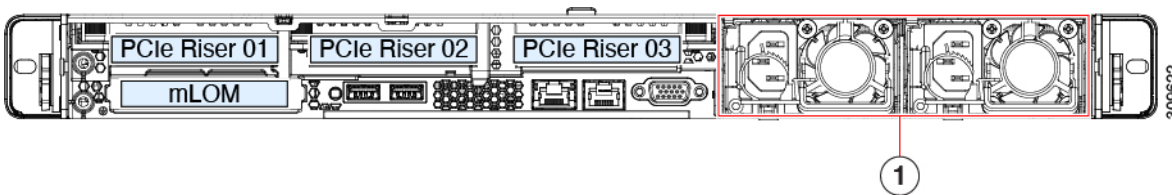

<b>1</b>	Power Supply location.
----------	------------------------

## Replacing DC Power Supplies



**Note** This procedure is for replacing DC power supplies in a server that already has DC power supplies installed. If you are installing DC power supplies to the server for the first time, see [Installing DC Power Supplies \(First Time Installation\)](#).



**Warning** A readily accessible two-poled disconnect device must be incorporated in the fixed wiring.

Statement 1022



**Warning** This product requires short-circuit (overcurrent) protection, to be provided as part of the building installation. Install only in accordance with national and local wiring regulations.

Statement 1045



**Warning** Installation of the equipment must comply with local and national electrical codes.

Statement 1074



**Note** If you are replacing DC power supplies in a server with power supply redundancy (two power supplies), you do not have to power off the server to replace a power supply because they are redundant as 1+1.



**Note** Do not mix power supply types or wattages in the server. Both power supplies must be identical.

### Procedure

**Step 1** Remove the DC power supply that you are replacing or a blank panel from an empty bay:

a) Perform one of the following actions:

- If you are replacing a power supply in a server that has only one DC power supply, shut down and remove power from the server as described in [Shutting Down and Removing Power From the Server, on page 35](#).
- If you are replacing a power supply in a server that has two DC power supplies, you do not have to shut down the server.

b) Remove the power cord from the power supply that you are replacing. Lift the connector securing clip slightly and then pull the connector from the socket on the power supply.

- c) Grasp the power supply handle while pinching the release lever toward the handle.
- d) Pull the power supply out of the bay.

**Step 2**

Install a new DC power supply:

- a) Grasp the power supply handle and insert the new power supply into the empty bay.
- b) Push the power supply into the bay until the release lever locks.
- c) Connect the power cord to the new power supply. Press the connector into the socket until the securing clip clicks into place.
- d) Only if you shut down the server, press the Power button to boot the server to main power mode.

**Figure 27: Replacing DC Power Supplies**

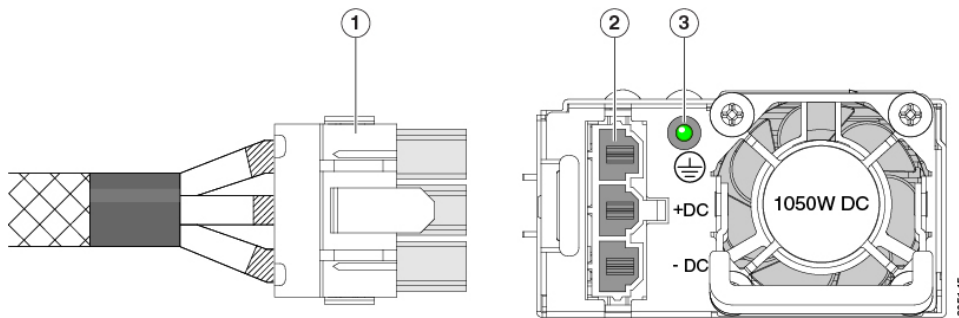

1	Keyed cable connector (CAB-48DC-40A-8AWG)	3	PSU status LED
2	Keyed DC input socket	-	

## Installing DC Power Supplies (First Time Installation)



**Note** This procedure is for installing DC power supplies to the server for the first time. If you are replacing DC power supplies in a server that already has DC power supplies installed, see [Replacing DC Power Supplies](#).



**Warning** A readily accessible two-poled disconnect device must be incorporated in the fixed wiring.

Statement 1022



**Warning** This product requires short-circuit (overcurrent) protection, to be provided as part of the building installation. Install only in accordance with national and local wiring regulations.

Statement 1045



**Warning** Installation of the equipment must comply with local and national electrical codes.

Statement 1074



**Note** Do not mix power supply types or wattages in the server. Both power supplies must be identical.



**Caution** As instructed in the first step of this wiring procedure, turn off the DC power source from your facility's circuit breaker to avoid electric shock hazard.

**Procedure**

**Step 1** Turn off the DC power source from your facility's circuit breaker to avoid electric shock hazard.

**Note**

The required DC input cable is Cisco part CAB-48DC-40A-8AWG. This 3-meter cable has a 3-pin connector on one end that is keyed to the DC input socket on the power supply. The other end of the cable has no connector so that you can wire it to your facility's DC power.

**Step 2** Wire the non-terminated end of the cable to your facility's DC power input source.

**Step 3** Connect the terminated end of the cable to the socket on the power supply. The connector is keyed so that the wires align for correct polarity and ground.

**Step 4** Return DC power from your facility's circuit breaker.

**Step 5** Press the Power button to boot the server to main power mode.

*Figure 28: Installing DC Power Supplies*

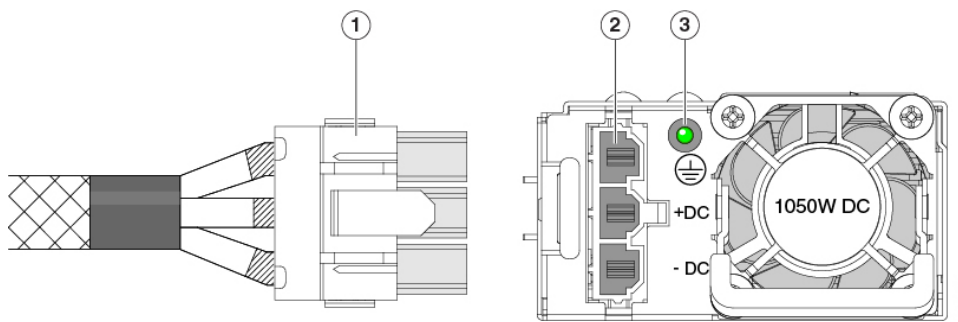

1	Keyed cable connector (CAB-48DC-40A-8AWG)	3	PSU status LED
2	Keyed DC input socket	-	

**Step 6** See [Grounding for DC Power Supplies](#) for information about additional chassis grounding.

## Grounding for DC Power Supplies

AC power supplies have internal grounding and so no additional grounding is required when the supported AC power cords are used.

When using a DC power supply, additional grounding of the server chassis to the earth ground of the rack is available. Two screw holes for use with your dual-hole grounding lug and grounding wire are supplied on the chassis rear panel.



---

**Note** The grounding points on the chassis are sized for 10-32 screws. You must provide your own screws, grounding lug, and grounding wire. The grounding lug must be dual-hole lug that fits 10-32 screws. The grounding cable that you provide must be 10 AWG (5 mm), minimum 60° C wire, or as permitted by the local code.

---

## Replacing a PCIe Riser

This server has toolless PCIe risers for horizontal installation of PCIe cards. Each riser is available in multiple versions. See [PCIe Slot Specifications, on page 72](#) for detailed descriptions of the slots and features in each riser version.

### Procedure

---

**Step 1** Shut down and remove power from the server as described in [Shutting Down and Removing Power From the Server, on page 35](#).

**Step 2** Slide the server out the front of the rack far enough so that you can remove the top cover. You might have to detach cables from the rear panel to provide clearance.

**Caution**

If you cannot safely view and access the component, remove the server from the rack.

**Step 3** Remove the top cover from the server as described in [Removing the Server Top Cover, on page 37](#).

**Step 4** Remove the PCIe riser that you are replacing:

- Grasp the flip-up handle on the riser and the blue forward edge, and then lift up evenly to disengage its circuit board from the socket on the motherboard. Set the riser on an antistatic surface.
- If the riser has a card installed, remove the card from the riser. See [Replacing a PCIe Card, on page 73](#).

**Step 5** Install a new PCIe riser:

**Note**

The PCIe risers are not interchangeable. If you plug a PCIe riser into the wrong socket, the server will not boot. Riser 1 must plug into the motherboard socket labeled “RISER1.” Riser 2 must plug into the motherboard socket labeled “RISER2.”

- If you removed a card from the old PCIe riser, install the card to the new riser. See [Replacing a PCIe Card, on page 73](#).
- Position the PCIe riser over its socket on the motherboard and over its alignment slots in the chassis.
- Carefully push down on both ends of the PCIe riser to fully engage its circuit board connector with the socket on the motherboard.

**Step 6** Replace the top cover to the server.

**Step 7** Replace the server in the rack, replace cables, and then fully power on the server by pressing the Power button.

*Figure 29: PCIe Riser Alignment - Two Riser Configuration*

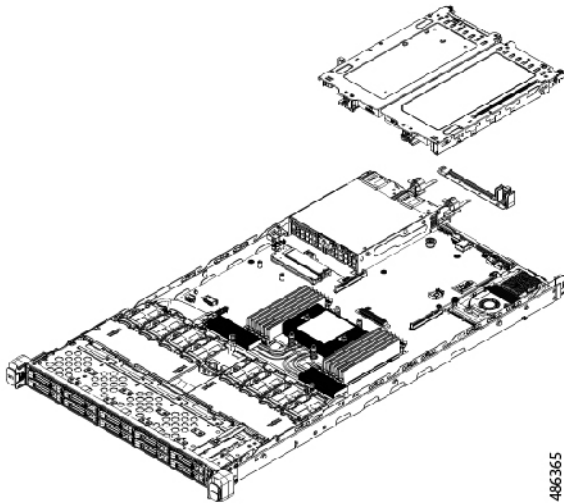

*Figure 30: PCIe Riser Alignment - Three Riser Configuration*

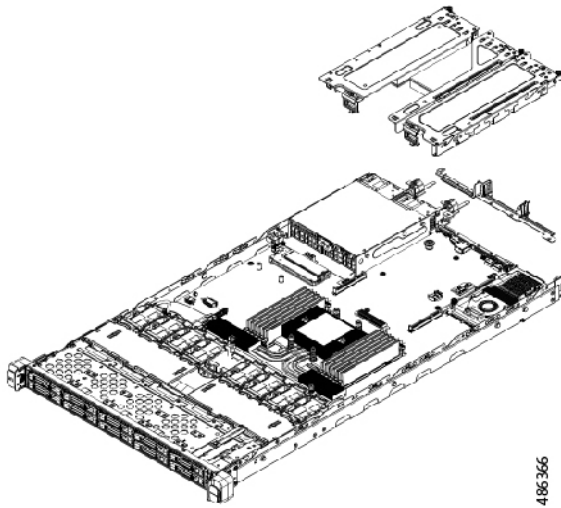

## Replacing NVMe Cable

### Procedure

**Step 1** Prepare the server for component installation:

- Shut down and remove power from the server as described in [Shutting Down and Removing Power From the Server](#), on page 35.

- b) Slide the server out the front of the rack far enough so that you can remove the top cover. You might have to detach cables from the rear panel to provide clearance.

**Caution**

If you cannot safely view and access the component, remove the server from the rack.

- c) Remove the top cover from the server as described in [Removing the Server Top Cover, on page 37](#).  
 d) Remove the air baffle to provide clearance.

**Step 2** Replacing the cable:

- Required Cables:
  - MCIO cable (Y Cable X16 to X4 + X4 + X8)
  - MCIO cable (Y Cable X16 to X8 + X8)
  - MCIO cable (X8 to X8)

1 (Blue)	NVMe-1 on motherboard (MB) to CN24, CN25 and CN26 on backplane (BP) side	MCIO cable (Y Cable X16 to X4 + X4 + X8)
2 (Green)	NVMe-2 on MB to CN21 and CN21 and CN22 on BP side	MCIO cable (Y Cable X16 to X8 + X8)
3 (Orange)	NVMe-3 on motherboard (MB) to CN23 on BP side (not shown in the figure)	MCIO cable (X8 to X8)
4 (Yellow)	Front KVM cable	
5 (Red)	HDD BP PWR cable	

**Figure 31: NVMe-1, 2 and 3 on Motherboard and Connectors on Backplane**

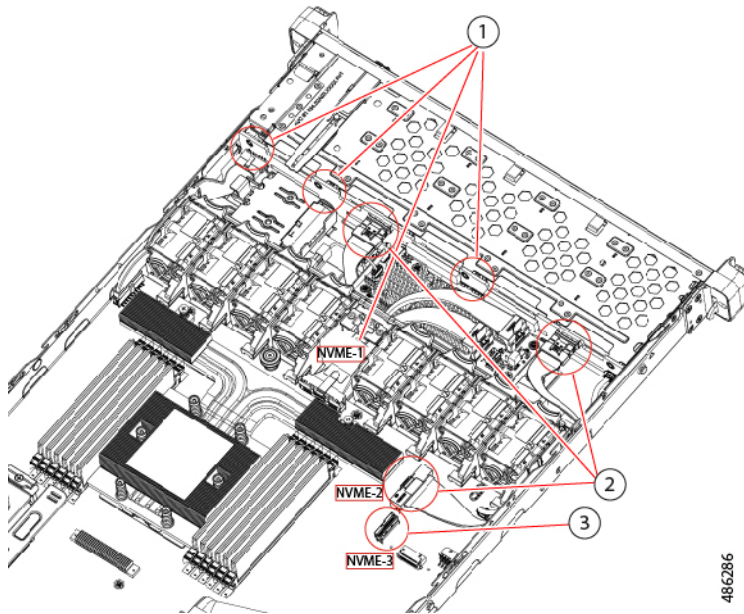

486286

**Step 3** Route the cables as described in the following image.

**Figure 32: NVMe-1, 2 and 3 on Motherboard and Connectors on Backplane**

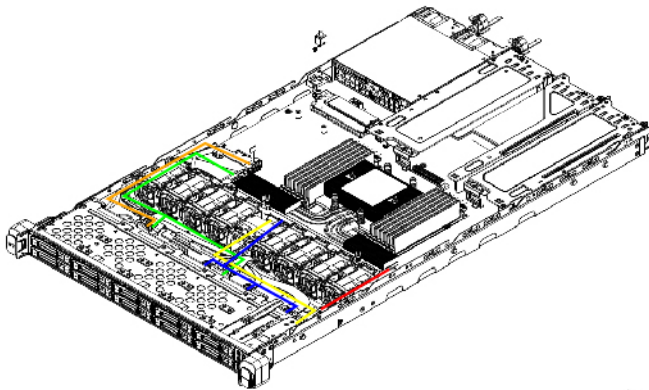

486367

# Replacing a PCIe Card



**Note** Cisco supports all PCIe cards qualified and sold by Cisco. PCIe cards not qualified or sold by Cisco are the responsibility of the customer. Although Cisco will always stand behind and support the C-Series rack-mount servers, customers using standard, off-the-shelf, third-party cards must go to the third-party card vendor for support if any issue with that particular card occurs.

## PCIe Slot Specifications

The following tables describe the specifications for the slots in three riser combination.

**Table 5: PCIe Riser 1**

Slot Number	Electrical Lane Width	Connector Length	Maximum Card Length	Card Height (Rear Panel Opening)	NCSI Support
1A	Gen4 x16	x24 connector	$\frac{3}{4}$ length	Half-height	Yes
1B	Gen5 x16	x24 connector	$\frac{3}{4}$ length	Half-height	Yes

**Table 6: PCIe Riser 2**

Slot Number	Electrical Lane Width	Connector Length	Maximum Card Length	Card Height (Rear Panel Opening)	NCSI Support
2A	Gen4 x16	x24 connector	$\frac{3}{4}$ length	Half-height	No
2B	Gen5 x16	x24 connector	$\frac{3}{4}$ length	Half-height	No

**Table 7: PCIe Riser 3**

Slot Number	Electrical Lane Width	Connector Length	Maximum Card Length	Card Height (Rear Panel Opening)	NCSI Support
3A	Gen4 x16	x24 connector	$\frac{3}{4}$ length	Half-height	Yes

The following tables describe the specifications for the slots in two riser combination.

**Table 8: PCIe Riser 1**

Slot Number	Electrical Lane Width	Connector Length	Maximum Card Length	Card Height (Rear Panel Opening)	NCSI Support
1C	Gen5 x16	x24 connector	$\frac{3}{4}$ length	Full-height	Yes

Table 9: PCIe Riser 3

Slot Number	Electrical Lane Width	Connector Length	Maximum Card Length	Card Height (Rear Panel Opening)	NCSI Support
3C	Gen5 x16	x24 connector	¾ length	Full-height	Yes

## Replacing a PCIe Card

### Procedure

**Step 1** Remove an existing PCIe card (or a blank filler panel) from the PCIe riser:

- a) Shut down and remove power from the server as described in [Shutting Down and Removing Power From the Server, on page 35](#).
- b) Slide the server out the front of the rack far enough so that you can remove the top cover. You might have to detach cables from the rear panel to provide clearance.

**Caution**

If you cannot safely view and access the component, remove the server from the rack.

- c) Remove the top cover from the server as described in [Removing the Server Top Cover, on page 37](#).
- d) Remove any cables from the ports of the PCIe card that you are replacing.
- e) Use two hands to grasp the external riser handle and the blue area at the front of the riser.
- f) Lift straight up to disengage the riser's connectors from the two sockets on the motherboard. Set the riser upside-down on an antistatic surface.
- g) Open the hinged plastic retainer that secures the rear-panel tab of the card.
- h) Pull evenly on both ends of the PCIe card to remove it from the socket on the PCIe riser.

If the riser has no card, remove the blanking panel from the rear opening of the riser.

**Step 2** Install a new PCIe card:

- a) With the hinged tab retainer open, align the new PCIe card with the empty socket on the PCIe riser.  
PCIe riser 1/slot 1 has a long-card guide at the front end of the riser. Use the slot in the long-card guide to help support a full-length card.
- b) Push down evenly on both ends of the card until it is fully seated in the socket.
- c) Ensure that the card's rear panel tab sits flat against the riser rear-panel opening and then close the hinged tab retainer over the card's rear-panel tab.

Figure 33: PCIe Riser Card Securing Mechanisms

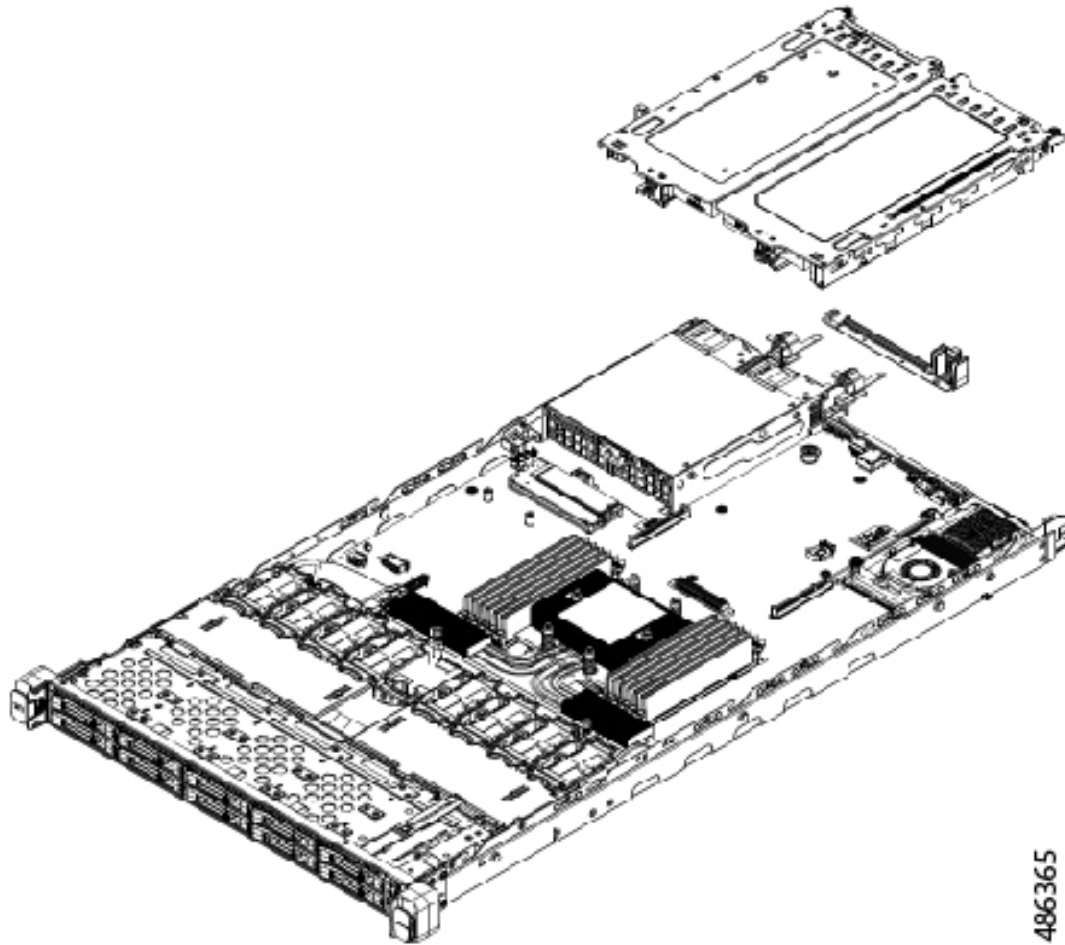

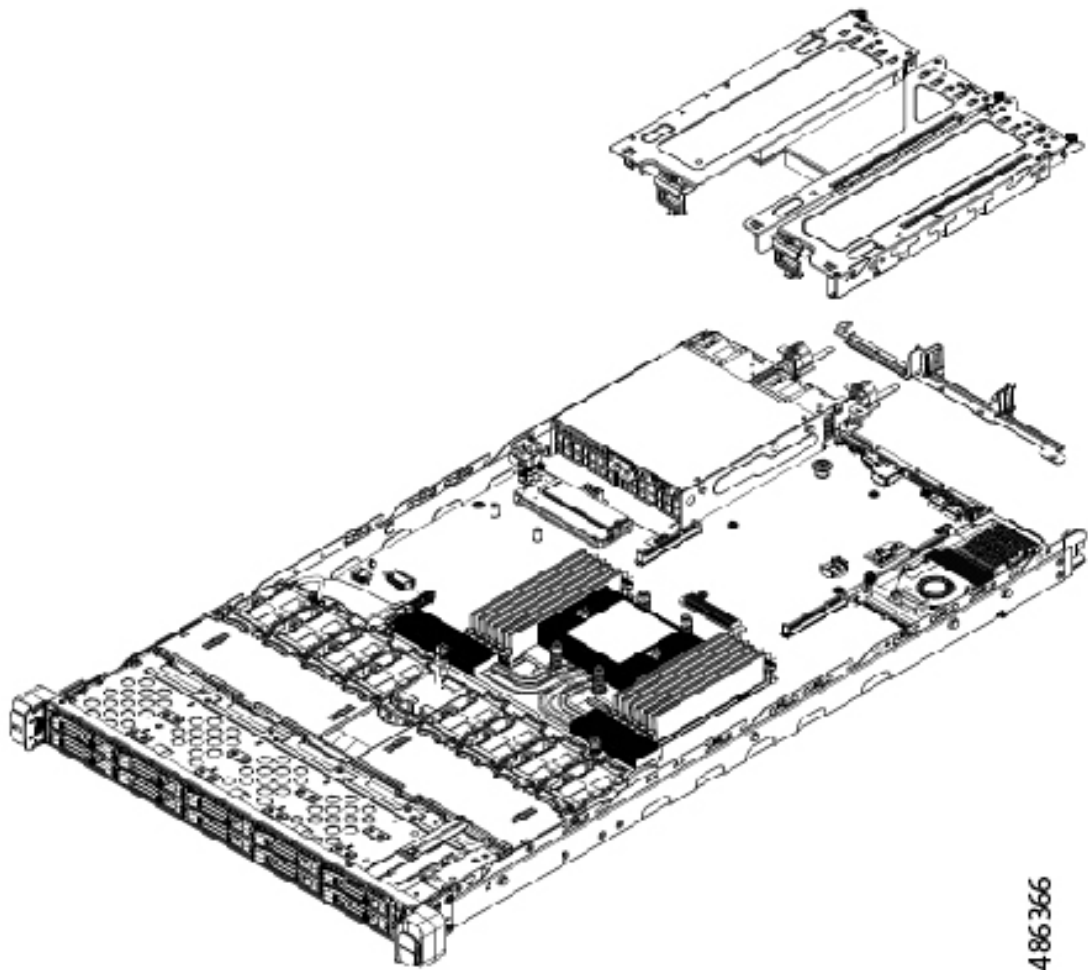

- d) Position the PCIe riser over its mating socket on the motherboard and over the two chassis alignment channels.
- e) Carefully push down on both ends of the PCIe riser to fully engage its connector with the socket on the motherboard.
- f) Replace the top cover to the server.
- g) Replace the server in the rack, replace cables, and then fully power on the server by pressing the Power button.

## Cisco VIC mLOM and OCP Card Replacement Considerations

In Cisco UCS servers, Cisco IMC network connection may be lost in the following situations, while replacing Cisco VIC mLOM and OCP cards:

- If OCP card is replaced by Cisco VIC card in MLOM Slot and the NIC mode is set to **Shared OCP** or **Shared OCP Extended**.
- If Cisco VIC Card in MLOM Slot is replaced by OCP Card and NIC mode is set to **Cisco-card MLOM**.

Follow these recommendations while replacing Cisco VIC mLOM or OCP cards in Cisco UCS servers to avoid loss of connectivity:

- Before replacing the card, configure any of the NIC modes that has network connected, other than **Cisco card MLOM**, **Shared OCP**, or **Shared OCP Extended**. After replacing the card, configure the appropriate NIC mode.

To set the NIC mode, refer *Server NIC Configuration* section in [Configuration Guides](#) for your Cisco IMC release.

- Or, after replacing the card, configure the appropriate NIC mode using Cisco IMC Configuration Utility/F8. Refer *Connecting to the Server Locally For Setup* section in [Install and Upgrade Guides](#) for your server.
- Or, after replacing the card, perform factory default settings using Cisco IMC Configuration Utility/F8 then perform the following steps:
  1. Once the server is rebooted, boot the system to Cisco IMC Configuration Utility/F8 then change the default password.
  2. Configure the appropriate NIC mode settings.

**Table 10: Factory Default Settings**

VIC in mLOM slot	Intel OCP 3.0 NIC in mLOM Slot	VIC in Riser Slot	Dedicated Management Port	NIC Mode for CIMC Access
Yes	No	No	Yes	<b>Cisco Card</b> mode with the card in mLOM Slot
No	Yes	No	Yes	<b>Shared OCP Extended</b>
No	Yes	Yes	Yes	<b>Shared OCP Extended</b>
No	No	Yes	Yes	<b>Cisco Card</b> with VIC SLOT based on precedence: <ol style="list-style-type: none"> <li>1. Riser 1 - Slot 1</li> <li>2. Riser 3 - Slot 3</li> </ol>
No	No	No	Yes	<b>Dedicated</b>

## Replacing an mLOM Card

The server supports a modular LOM (mLOM) card to provide additional rear-panel connectivity. The mLOM socket is on the motherboard, under PCIe Riser 1.

The mLOM socket provides a Gen-3 and Gen-4 x16 PCIe lane. The socket remains powered when the server is in 12 V standby power mode and it supports the network communications services interface (NCSI) protocol.

## Procedure

- Step 1** Remove any existing mLOM card (or a blanking panel):
- Shut down and remove power from the server as described in [Shutting Down and Removing Power From the Server, on page 35](#).
  - Slide the server out the front of the rack far enough so that you can remove the top cover. You might have to detach cables from the rear panel to provide clearance.

**Caution**

If you cannot safely view and access the component, remove the server from the rack.

- Remove the top cover from the server as described in [Removing the Server Top Cover, on page 37](#).
- Remove the mRAID riser to provide access to the mLOM socket below the riser.

To remove the mRAID riser, use both hands to grasp the external blue handle on the rear and the blue finger-grip on the front. Lift straight up.

You do not have to disconnect cables from any RAID card or interposer card that is installed in the riser. Carefully move the riser aside only far enough to provide clearance.

- Loosen the single captive thumbscrew that secures the mLOM card to the threaded standoff on the chassis floor.
- Slide the mLOM card horizontally to free it from the socket, then lift it out of the server.

- Step 2** Install a new mLOM card:

- Set the mLOM card on the chassis floor so that its connector is aligned with the motherboard socket.
- Push the card horizontally to fully engage the card's edge connector with the socket.
- Tighten the captive thumbscrew to secure the card to the standoff on the chassis floor.
- Return the mRAID riser to its socket.

Carefully align the riser's edge connector with the motherboard socket at the same time you align the two channels on the riser with the two pegs on the inner chassis wall. Press down evenly on both ends of the riser to fully engage its connector with the motherboard socket.

- Replace the top cover to the server.
- Replace the server in the rack, replace cables, and then fully power on the server by pressing the Power button.

Figure 34: mLOM Card Location

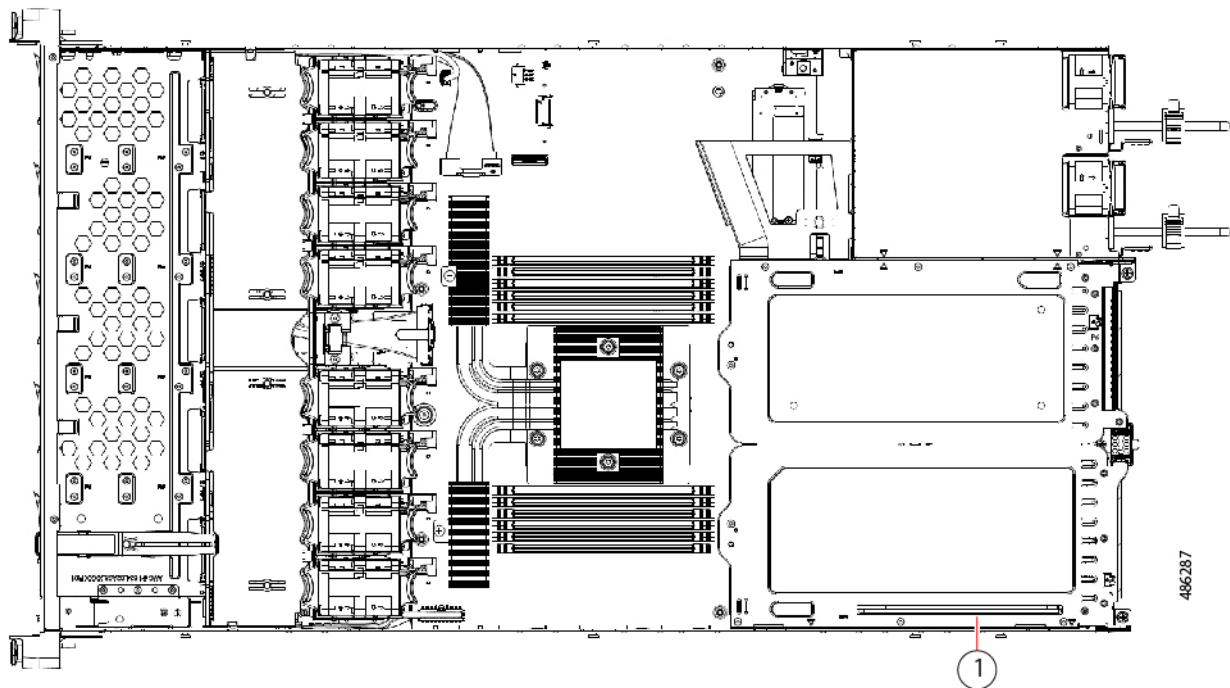

1

Position of horizontal mLOM card socket under PCIe riser 1

## Replacing a SAS Storage Controller Card (RAID or HBA)

For hardware-based storage control, the server can use a Cisco modular SAS RAID controller or SAS HBA that plugs into a dedicated, vertical socket on the motherboard.

### Storage Controller Card Firmware Compatibility

Firmware on the storage controller (RAID or HBA) must be verified for compatibility with the current Cisco IMC and BIOS versions that are installed on the server. If not compatible, upgrade or downgrade the storage controller firmware using the Host Upgrade Utility (HUU) for your firmware release to bring it to a compatible level.



**Note** For servers running in standalone mode only: After you replace controller hardware (UCSC-RAID-HP, UCSC-RAID-M1L16, UCSC-HBA-M1L16), you must run the Cisco UCS Host Upgrade Utility (HUU) to update the controller firmware, even if the firmware Current Version is the same as the Update Version. This is necessary to program the controller's suboem-id to the correct value for the server SKU. If you do not do this, drive enumeration might not display correctly in the software. This issue does not affect servers controlled in UCSM mode.

See the HUU guide for your Cisco IMC release for instructions on downloading and using the utility to bring server components to compatible levels: [HUU Guides](#).

## Replacing a SAS Storage Controller Card (RAID or HBA)

### Procedure

#### Step 1

Prepare the server for component installation:

- a) Shut down and remove power from the server as described in [Shutting Down and Removing Power From the Server, on page 35](#).
- b) Slide the server out the front of the rack far enough so that you can remove the top cover. You might have to detach cables from the rear panel to provide clearance.

#### Caution

If you cannot safely view and access the component, remove the server from the rack.

- c) Remove the top cover from the server as described in [Removing the Server Top Cover, on page 37](#).

#### Step 2

Remove any existing storage controller card from the server:

#### Note

The chassis includes a plastic mounting bracket that the card must be attached to before installation. During replacement, you must remove the old card from the bracket and then install the new card to the bracket before installing this assembly to the server.

- a) Disconnect SAS/SATA cables and any Supercap cable from the existing card.
- b) Lift up on the card's blue ejector lever to unseat it from the motherboard socket.
- c) Lift straight up on the card's carrier frame to disengage the card from the motherboard socket and to disengage the frame from two pegs on the chassis wall.
- d) Remove the existing card from its plastic carrier bracket. Carefully push the retainer tabs aside and then lift the card from the bracket.

#### Step 3

Install a new storage controller card:

- a) Install the new card to the plastic carrier bracket. Make sure that the retainer tabs close over the edges of the card.
- b) Position the assembly over the chassis and align the card edge with the motherboard socket. At the same time, align the two slots on the back of the carrier bracket with the pegs on the chassis inner wall.
- c) Push on both corners of the card to seat its connector in the riser socket. At the same time, ensure that the slots on the carrier frame engage with the pegs on the inner chassis wall.
- d) Fully close the blue ejector lever on the card to lock the card into the socket.
- e) Connect SAS/SATA cables and any Supercap cable to the new card.

If this is a first-time installation, see [Storage Controller Cable Connectors and Backplanes, on page 125](#) for cabling instructions.

#### Step 4

Replace the top cover to the server.

#### Step 5

Replace the server in the rack, replace cables, and then fully power on the server by pressing the Power button.

#### Step 6

If your server is running in standalone mode, use the Cisco UCS Host Upgrade Utility to update the controller firmware and program the correct suboem-id for the controller.

#### Note

**For servers running in standalone mode only:** After you replace controller hardware (UCSC-RAID-HP, UCSC-RAID-M1L16, UCSC-HBA-M1L16), you must run the Cisco UCS Host Upgrade Utility (HUU) to update the controller firmware, even if the firmware Current Version is the same as the Update Version. This is necessary to program the controller's suboem-id to the correct value for the server SKU. If you do not do this, drive enumeration might not display correctly in the software. This issue does not affect servers controlled in UCSM mode.

See the HUU guide for your Cisco IMC release for instructions on downloading and using the utility to bring server components to compatible levels: [HUU Guides](#).

**Figure 35: Storage Controller Card Location**

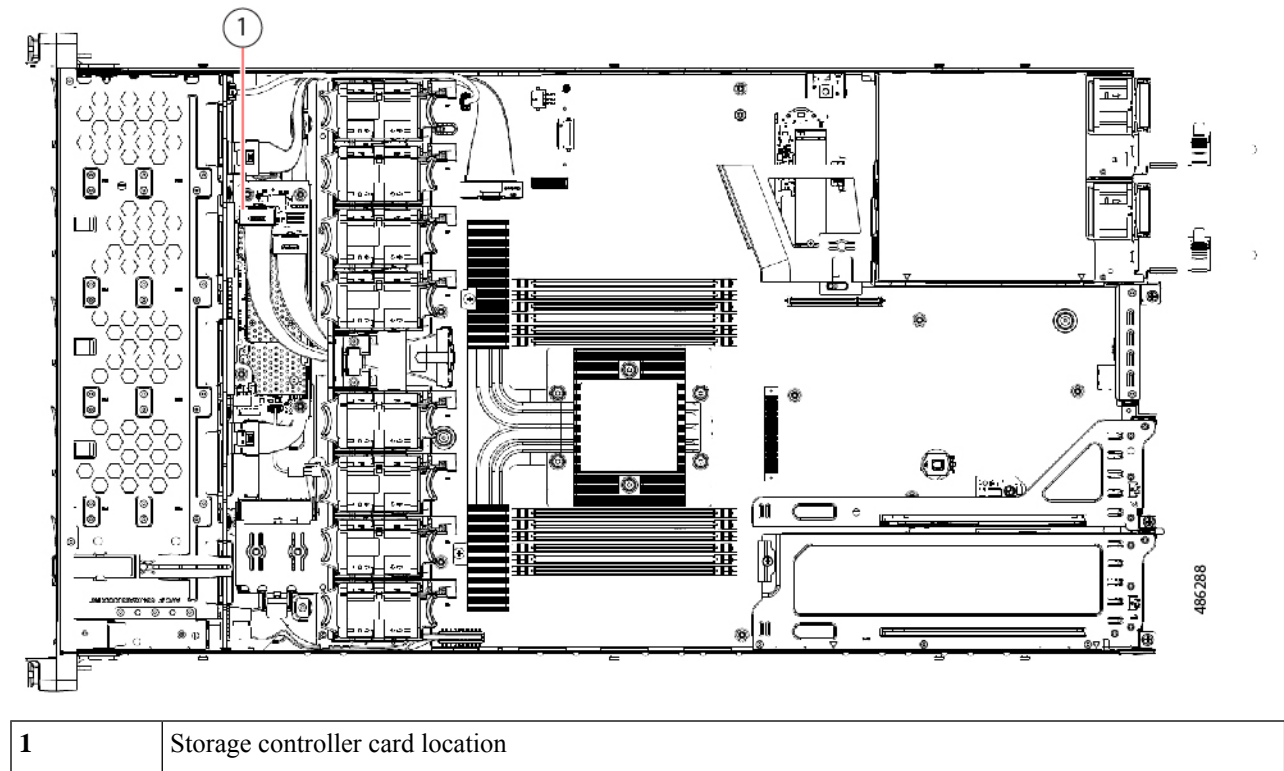

## Replacing the Supercap (RAID Backup)

This server supports installation of one Supercap unit. The unit mounts to a bracket that is in the middle of the row of cooling fan modules.

The Supercap provides approximately three years of backup for the disk write-back cache DRAM in the case of a sudden power loss by offloading the cache to the NAND flash.

### Procedure

**Step 1** Prepare the server for component installation:

- a) Shut down and remove power from the server as described in [Shutting Down and Removing Power From the Server, on page 35](#).
- b) Slide the server out the front of the rack far enough so that you can remove the top cover. You might have to detach cables from the rear panel to provide clearance.

**Caution**

If you cannot safely view and access the component, remove the server from the rack.

- c) Remove the top cover from the server as described in [Removing the Server Top Cover, on page 37](#).

**Step 2** Remove an existing Supercap:

- a) Disconnect the Supercap cable from the existing Supercap.
- b) Push aside the securing tab to open the hinged latch that secures the Supercap to its bracket on the removable air baffle.
- c) Lift the Supercap free of the bracket and set it aside.

**Step 3** Install a new Supercap:

- a) Set the new Supercap into the mounting bracket.
- b) Close the hinged plastic clip over the Supercap. Push down until the securing tab clicks.
- c) Connect the Supercap cable from the RAID controller card to the connector on the new Supercap cable.

**Step 4** Replace the top cover to the server.

**Step 5** Replace the server in the rack, replace cables, and then fully power on the server by pressing the Power button.

---

## Replacing a Boot-Optimized M.2 RAID Controller Module

The Cisco Boot-Optimized M.2 RAID Controller module connects to the mini-storage module socket on the motherboard. It includes slots for two SATA M.2 drives that can control the SATA M.2 drives in a RAID 1 array and JBOD mode.

## Replacing a Cisco Boot-Optimized M.2 RAID Controller

This topic describes how to remove and replace a Cisco Boot-Optimized M.2 RAID Controller. The controller board has one M.2 socket on its top (Slot 1) and one M.2 socket on its underside (Slot 2).

### Procedure

---

**Step 1** Shut down and remove power from the server as described in [Shutting Down and Removing Power From the Server, on page 35](#).

**Step 2** Slide the server out the front of the rack far enough so that you can remove the top cover. You might have to detach cables from the rear panel to provide clearance.

**Caution**

If you cannot safely view and access the component, remove the server from the rack.

**Step 3** Remove the top cover from the server as described in [Removing the Server Top Cover, on page 37](#).

**Step 4** Grasp and remove the air baffle located in front of the PSUs.

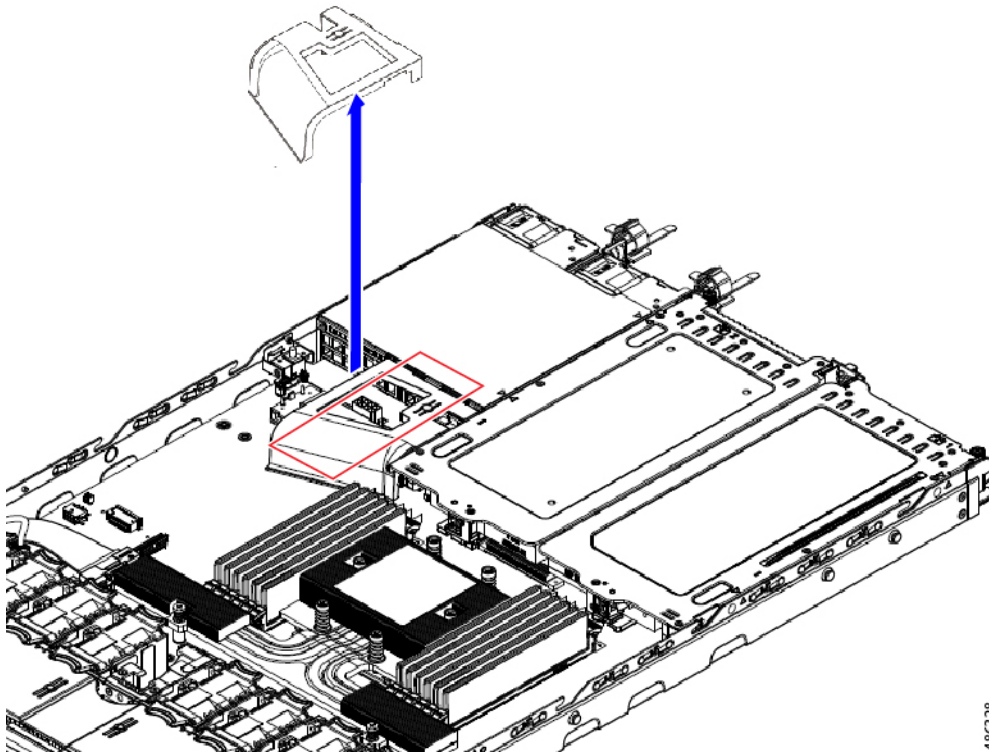

486328

- Step 5** Remove a controller from its motherboard socket:
- Locate the controller in its socket just behind CPU 2.

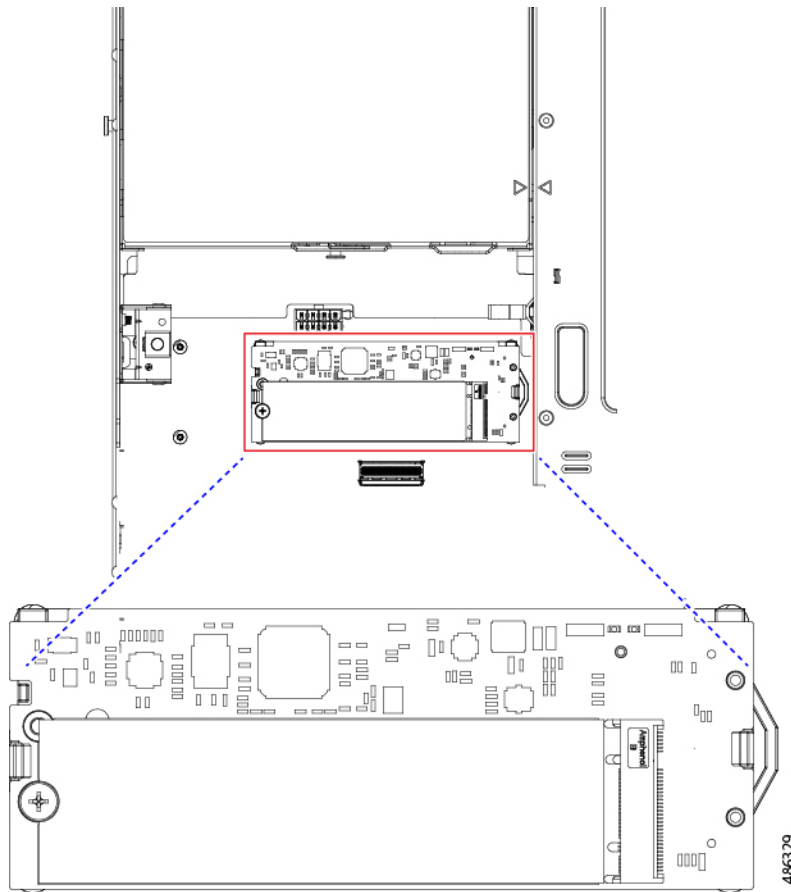

- b) At each end of the controller board, push outward on the clip that secures the carrier.
- c) Lift both ends of the controller to disengage it from the socket on the motherboard.
- d) Set the carrier on an anti-static surface.

<b>1</b>	Location of socket on motherboard	<b>3</b>	Securing clips
<b>2</b>	Alignment pegs	-	

**Step 6** If you are transferring SATA M.2 drives from the old controller to the replacement controller, do that before installing the replacement controller:

**Note**

Any previously configured volume and data on the drives are preserved when the M.2 drives are transferred to the new controller. The system will boot the existing OS that is installed on the drives.

- a) Use a #1 Phillips-head screwdriver to remove the single screw that secures the M.2 drive to the carrier.
- b) Lift the M.2 drive from its socket on the carrier.
- c) Position the replacement M.2 drive over the socket on the controller board.
- d) Angle the M.2 drive downward and insert the connector-end into the socket on the carrier. The M.2 drive's label must face up.
- e) Press the M.2 drive flat against the carrier.
- f) Install the single screw that secures the end of the M.2 SSD to the carrier.

- g) Turn the controller over and install the second M.2 drive.

**Figure 36: Cisco Boot-Optimized M.2 RAID Controller, Showing M.2 Drive Installation**

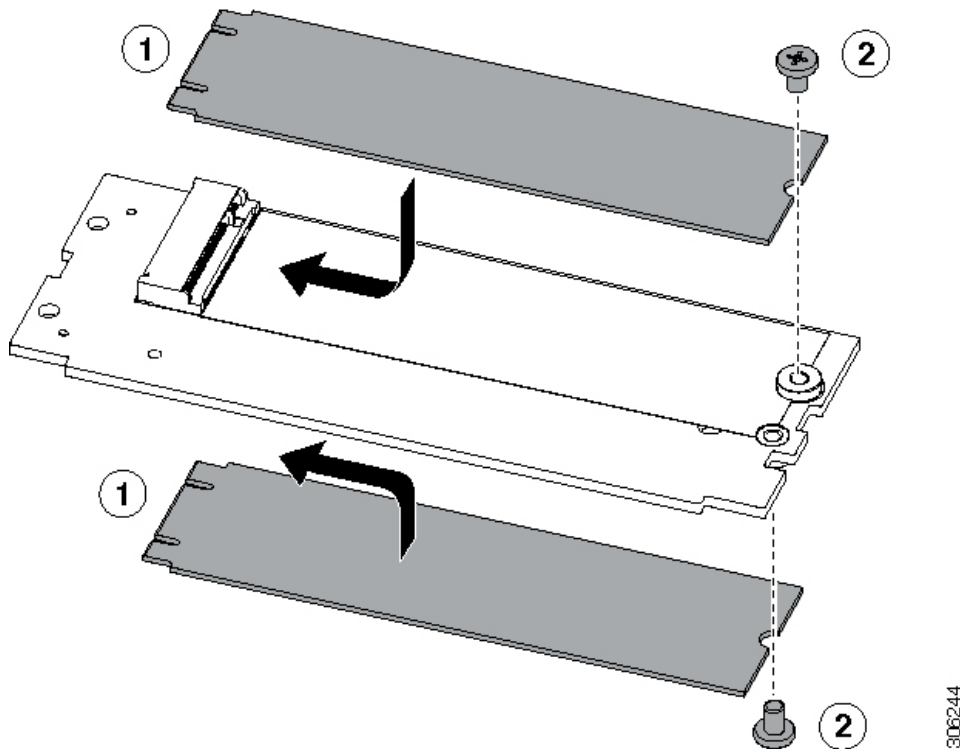

- Step 7** Install the controller to its socket on the motherboard:
- Position the controller over socket, with the controller's connector facing down and at the same end as the motherboard socket. Two alignment pegs must match with two holes on the controller.
  - Gently push down the socket end of the controller so that the two pegs go through the two holes on the controller.
  - Push down on the controller so that the securing clips click over it at both ends.
- Step 8** Replace the top cover to the server.
- Step 9** Replace the server in the rack, replace cables, and then fully power on the server by pressing the Power button.

## Replacing a Chassis Intrusion Switch

The chassis intrusion switch is an optional security feature that logs an event in the system event log (SEL) whenever the cover is removed from the chassis.

### Procedure

- Step 1** Prepare the server for component installation:

- a) Shut down and remove power from the server as described in [Shutting Down and Removing Power From the Server, on page 35](#).
- b) Slide the server out the front of the rack far enough so that you can remove the top cover. You might have to detach cables from the rear panel to provide clearance.

**Caution**

If you cannot safely view and access the component, remove the server from the rack.

- c) Remove the top cover from the server as described in [Removing the Server Top Cover, on page 37](#).

**Step 2**

Remove an existing intrusion switch:

- a) Disconnect the intrusion switch cable from the socket on the motherboard.
- b) Use a #1 Phillips-head screwdriver to loosen and remove the single screw that holds the switch mechanism to the chassis wall.
- c) Slide the switch mechanism straight up to disengage it from the clips on the chassis.

**Step 3**

Install a new intrusion switch:

- a) Slide the switch mechanism down into the clips on the chassis wall so that the screwhole lines up.
- b) Use a #1 Phillips-head screwdriver to install the single screw that secures the switch mechanism to the chassis wall.
- c) Connect the switch cable to the socket on the motherboard.

**Step 4**

Replace the cover to the server.

**Step 5**

Replace the server in the rack, replace cables, and then fully power on the server by pressing the Power button.

**Figure 37: Intrusion Switch Location**

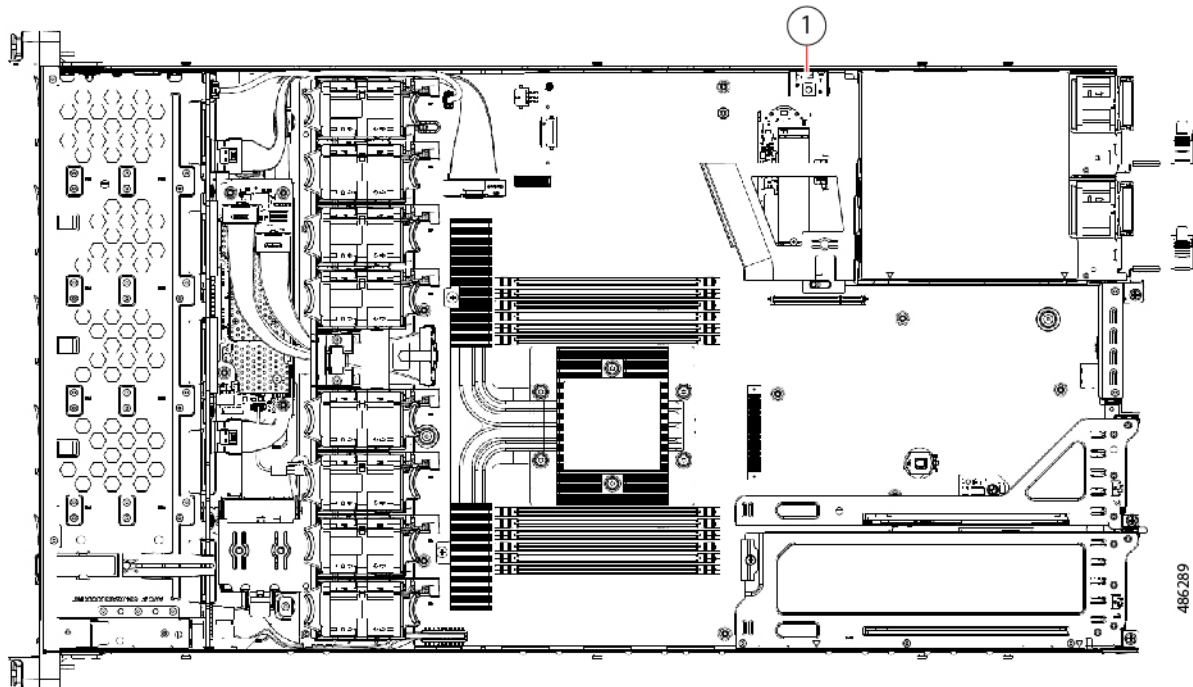

1	Intrusion switch location
---	---------------------------

# Installing a Trusted Platform Module (TPM)

The trusted platform module (TPM) is a small circuit board that plugs into a motherboard socket and is then permanently secured with a one-way screw.

## TPM Considerations

- This server supports TPM version 2.0.
- Field replacement of a TPM is not supported; you can install a TPM after-factory only if the server does not already have a TPM installed.
- If the TPM 2.0 becomes unresponsive, reboot the server.

## Installing and Enabling a TPM



---

**Note** Field replacement of a TPM is not supported; you can install a TPM after-factory only if the server does not already have a TPM installed.

---

This topic contains the following procedures, which must be followed in this order when installing and enabling a TPM:

1. Installing the TPM Hardware
2. Enabling the TPM in the BIOS

## Installing TPM Hardware



---

**Note** For security purposes, the TPM is installed with a one-way screw. It cannot be removed with a standard screwdriver.

---

### Procedure

#### Step 1

Prepare the server for component installation:

- a) Shut down and remove power from the server as described in [Shutting Down and Removing Power From the Server, on page 35](#).
- b) Slide the server out the front of the rack far enough so that you can remove the top cover. You might have to detach cables from the rear panel to provide clearance.

#### Caution

If you cannot safely view and access the component, remove the server from the rack.

c) Remove the top cover from the server as described in [Removing the Server Top Cover, on page 37](#).

**Step 2** Check if there is a card installed in PCIe riser 2:

- If no card is installed in PCIe riser 2, you can access the TPM socket. Go to the next step.
- If a card is installed in PCIe riser 2, remove the PCIe riser assembly from the chassis to provide clearance before continuing with the next step. See [Replacing a PCIe Card, on page 72](#) for instructions on removing the PCIe riser.

**Step 3** Install a TPM:

- Locate the TPM socket on the motherboard, as shown below.
- Align the connector that is on the bottom of the TPM circuit board with the motherboard TPM socket. Align the screw hole on the TPM board with the screw hole that is adjacent to the TPM socket.
- Push down evenly on the TPM to seat it in the motherboard socket.
- Install the single one-way screw that secures the TPM to the motherboard.
- If you removed the PCIe riser assembly to provide clearance, return it to the server now.

**Step 4** Replace the cover to the server.

**Step 5** Replace the server in the rack, replace cables, and then fully power on the server by pressing the Power button.

*Figure 38: TPM Socket Location on Motherboard*

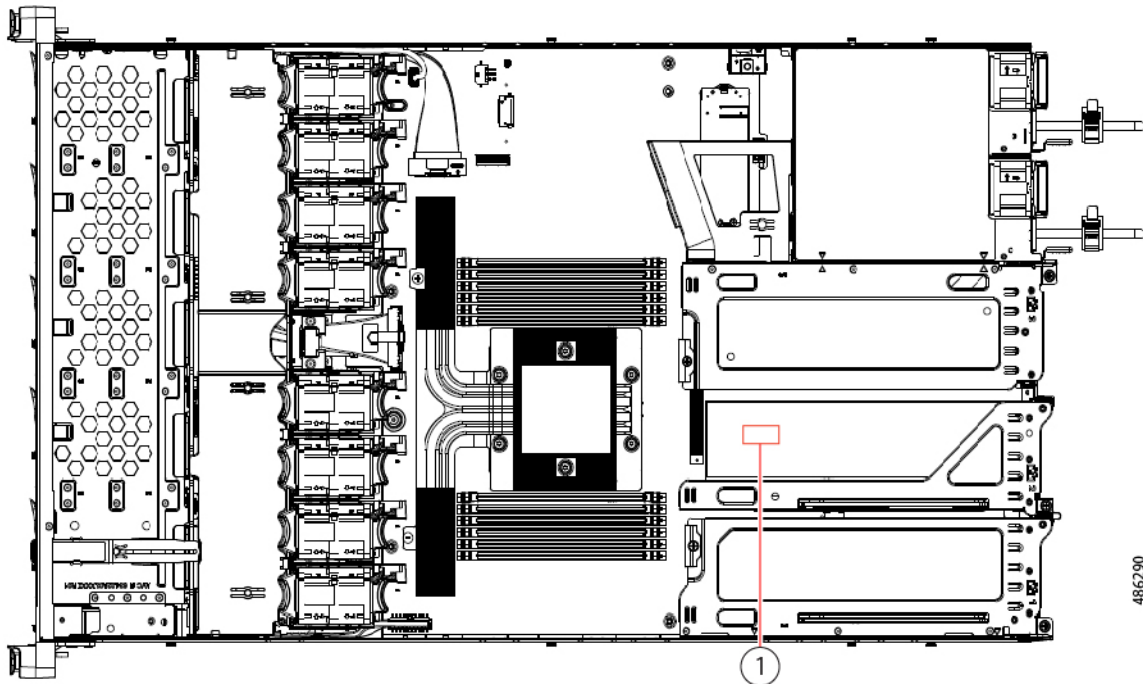

<b>1</b>	TPM socket location on motherboard below any card in PCIe riser 2
----------	---

**Step 6** Continue with [Enabling the TPM in the BIOS, on page 88](#).

## Enabling the TPM in the BIOS

After hardware installation, you must enable TPM support in the BIOS.



---

**Note** You must set a BIOS Administrator password before performing this procedure. To set this password, press the **F2** key when prompted during system boot to enter the BIOS Setup utility. Then navigate to **Security > Set Administrator Password** and enter the new password twice as prompted.

---

### Procedure

---

**Step 1** Enable TPM Support:

- a) Watch during bootup for the F2 prompt, and then press **F2** to enter BIOS setup.
- b) Log in to the BIOS Setup Utility with your BIOS Administrator password.
- c) On the BIOS Setup Utility window, choose the **Advanced** tab.
- d) Choose **Trusted Computing** to open the TPM Security Device Configuration window.
- e) Change TPM SUPPORT to **Enabled**.
- f) Press **F10** to save your settings and reboot the server.

**Step 2** Verify that TPM support is now enabled:

- a) Watch during bootup for the F2 prompt, and then press **F2** to enter BIOS setup.
  - b) Log into the BIOS Setup utility with your BIOS Administrator password.
  - c) Choose the **Advanced** tab.
  - d) Choose **Trusted Computing** to open the TPM Security Device Configuration window.
  - e) Verify that TPM SUPPORT and TPM State are Enabled.
- 

## Removing the PCB Assembly (PCBA)

The PCBA is secured to the server's sheet metal. You must disconnect the PCBA from the tray before recycling the PCBA. The PCBA is secured by different types of fasteners.

### Before you begin



---

**Note** **For Recyclers Only!** This procedure is not a standard field-service option. This procedure is for recyclers who will be reclaiming the electronics for proper disposal to comply with local eco design and e-waste regulations.

---

To remove the printed circuit board assembly (PCBA), the following requirements must be met:

- The server must be disconnected from facility power.
- The server must be removed from the equipment rack.

- The server's top cover must be removed. See [Removing the Server Top Cover](#), on page 37.

Following tools are required:

- Pliers
- T10 Torx screwdriver

**Procedure**

**Step 1** Locate the PCBA's mounting screws.

The following figure shows the location of the mounting screws and fasteners.

*Figure 39: Screw Locations for Removing the UCS C225 M8 PCBA*

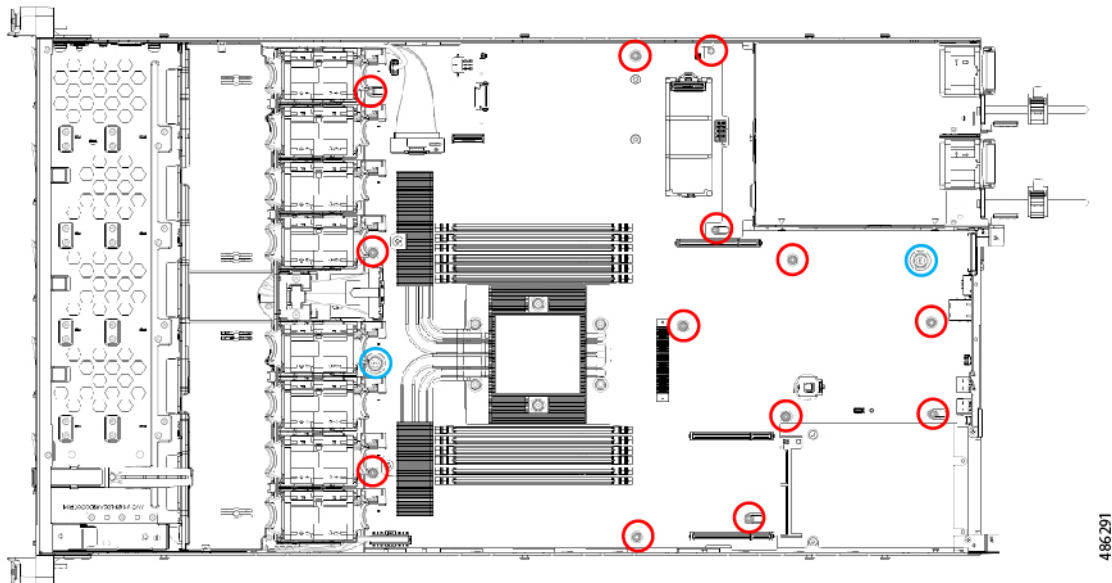

shown in red	Torque: 10.0 kgf-cm (8.68 in-lbs)
shown in blue	Torque: 5.0 kgf-cm (4.34 in-lbs)

**Step 2** Using a T10 Torx driver, remove all of the indicated screws.

**Step 3** Remove the PCBA from the sheetmetal and dispose of each in compliance with your local ewaste and recycling regulations.

## Service DIP Switch, Headers and Jumpers

This server includes one DIP switch (SW4) and header (CN5) that you can use for certain service and debug functions.

This section contains the following topics:

Figure 40: Location of DIP Switch and Service Header Blocks SW4 and CN5

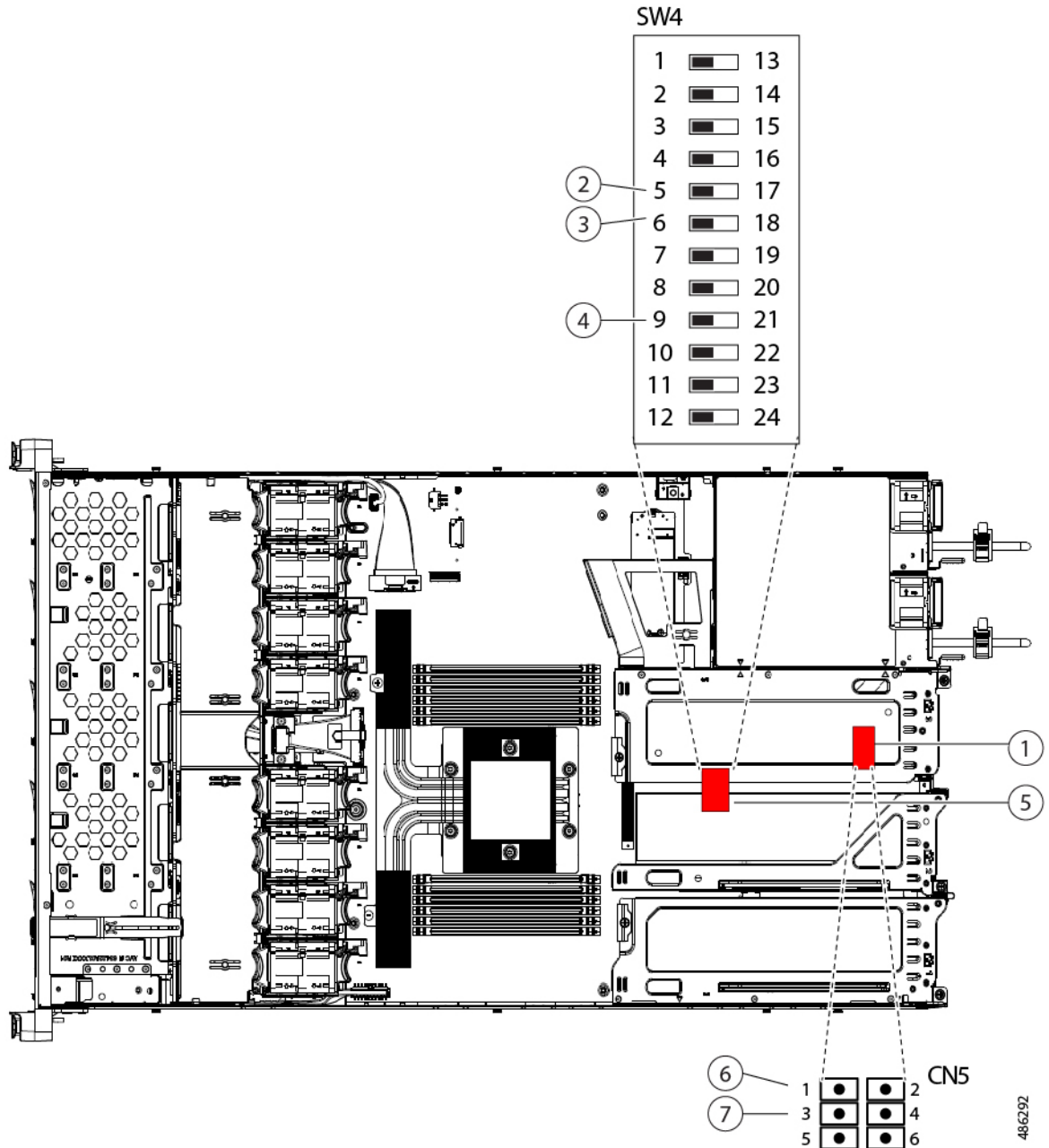

1	Location of header block CN5	5	Location of SW4 DIP switches
2	BIOS Recovery Switch (SW4 Switch 5 - 17) Off (Switch 5): Normal; ON (Switch 17): Recovery Mode	6	Boot Alternate Cisco IMC Header: CN5 pins 1 - 2
3	Clear BIOS Password Switch (SW4 Switch 6 - 18) Off (Switch 6): Normal; ON (Switch 18): Clear	7	System Secure Firmware Erase Header: CN5 pins 3 - 4

486292

4	Clear CMOS Switch (SW4 Switch 9 - 21) Off (Switch 9): Normal; ON (Switch 21): Clear		
---	---	--	--

## Using the BIOS Recovery Header (SW4, Pins 5 - 17)

Depending on which stage the BIOS becomes corrupted, you might see different behavior.

- If the BIOS BootBlock is corrupted, you might see the system get stuck on the following message:

```
Initializing and configuring memory/hardware
```

- If it is a non-BootBlock corruption, a message similar to the following is displayed:

```
****BIOS FLASH IMAGE CORRUPTED****
Flash a valid BIOS capsule file using Cisco IMC WebGUI or CLI interface.
IF Cisco IMC INTERFACE IS NOT AVAILABLE, FOLLOW THE STEPS MENTIONED BELOW.
1. Connect the USB stick with bios.cap file in root folder.
2. Reset the host.
IF THESE STEPS DO NOT RECOVER THE BIOS
1. Power off the system.
2. Mount recovery jumper.
3. Connect the USB stick with bios.cap file in root folder.
4. Power on the system.
Wait for a few seconds if already plugged in the USB stick.
REFER TO SYSTEM MANUAL FOR ANY ISSUES.
```



**Note** As indicated by the message shown above, there are two procedures for recovering the BIOS. Try procedure 1 first. If that procedure does not recover the BIOS, use procedure 2.

### Procedure 1: Reboot With bios.cap Recovery File

#### Procedure

**Step 1** Download the BIOS update package and extract it to a temporary location.

**Step 2** Copy the contents of the extracted recovery folder to the root directory of a USB drive. The recovery folder contains the bios.cap file that is required in this procedure.

**Note**

The bios.cap file must be in the root directory of the USB drive. Do not rename this file. The USB drive must be formatted with either the FAT16 or FAT32 file system.

**Step 3** Insert the USB drive into a USB port on the server.

**Step 4** Reboot the server.

**Step 5** Return the server to main power mode by pressing the Power button on the front panel.

The server boots with the updated BIOS boot block. When the BIOS detects a valid bios.cap file on the USB drive, it displays this message:

```
Found a valid recovery file...Transferring to Cisco IMC
System would flash the BIOS image now...
System would restart with recovered image after a few seconds...
```

**Step 6** Wait for server to complete the BIOS update, and then remove the USB drive from the server.

**Note**

During the BIOS update, Cisco IMC shuts down the server and the screen goes blank for about 10 minutes. Do not unplug the power cords during this update. Cisco IMC powers on the server after the update is complete.

## Procedure 2: Use BIOS Recovery DIP Switch and bios.cap Recovery File

### Procedure

**Step 1** Download the BIOS update package and extract it to a temporary location.

**Step 2** Copy the contents of the extracted recovery folder to the root directory of a USB drive. The recovery folder contains the bios.cap file that is required in this procedure.

**Note**

The bios.cap file must be in the root directory of the USB drive. Do not rename this file. The USB drive must be formatted with either the FAT16 or FAT32 file system.

**Step 3** Shut down and remove power from the server as described in [Shutting Down and Removing Power From the Server, on page 35](#). Disconnect power cords from all power supplies.

**Step 4** Slide the server out the front of the rack far enough so that you can remove the top cover. You might have to detach cables from the rear panel to provide clearance.

**Caution**

If you cannot safely view and access the component, remove the server from the rack.

**Step 5** Remove the top cover from the server as described in [Removing the Server Top Cover, on page 37](#).

**Step 6** Locate the SW4 is DIP Switch shown in [Service DIP Switch, Headers and Jumpers, on page 89](#). Default position is at Switch 5 (Off: normal). To set to BIOS recovery mode, switch to pin 17 position (ON: recovery mode).

**Step 7** Reconnect AC power cords to the server. The server powers up to standby power mode.

**Step 8** Insert the USB thumb drive that you prepared in Step 2 into a USB port on the server.

**Step 9** Return the server to main power mode by pressing the Power button on the front panel.

The server boots with the updated BIOS boot block. When the BIOS detects a valid bios.cap file on the USB drive, it displays this message:

```
Found a valid recovery file...Transferring to Cisco IMC
System would flash the BIOS image now...
System would restart with recovered image after a few seconds...
```

**Step 10** Wait for server to complete the BIOS update, and then remove the USB drive from the server.

**Note**

During the BIOS update, Cisco IMC shuts down the server and the screen goes blank for about 10 minutes. Do not unplug the power cords during this update. Cisco IMC powers on the server after the update is complete.

**Step 11** After the server has fully booted, power off the server.

**Step 12** Switch SW4 back to pin 5 position (Off: normal).

- Step 13** Replace the top cover, replace the server in the rack, replace power cords and any other cables, and then power on the server by pressing the Power button.
- 

## Using the Clear BIOS Password Switch (SW4, Pins 6 - 18)

You can use SW4 DIP switch to clear the administrator password.

### Procedure

---

- Step 1** Shut down and remove power from the server as described in [Shutting Down and Removing Power From the Server, on page 35](#). Disconnect power cords from all power supplies.

- Step 2** Slide the server out the front of the rack far enough so that you can remove the top cover. You might have to detach cables from the rear panel to provide clearance.

**Caution**

If you cannot safely view and access the component, remove the server from the rack.

- Step 3** Remove the top cover from the server as described in [Removing the Server Top Cover, on page 37](#).

- Step 4** Locate the SW4 DIP Switch and pins 6-18, as shown in [Service DIP Switch, Headers and Jumpers, on page 89](#).

Default position is at pin 6 (Off: normal).

- Step 5** To clear BIOS password, switch to pin 18 position (On: clear).

- Step 6** Reinstall the top cover and reconnect AC power cords to the server. The server powers up to standby power mode, indicated when the Power LED on the front panel is amber.

- Step 7** Return the server to main power mode by pressing the Power button on the front panel. The server is in main power mode when the Power LED is green.

**Note**

You must allow the entire server to reboot to main power mode to complete the reset. The state of the jumper cannot be determined without the host CPU running.

- Step 8** Press the Power button to shut down the server to standby power mode, and then remove AC power cords from the server to remove all power.

- Step 9** Remove the top cover from the server.

- Step 10** Switch SW4 back to pin 6 position (Off: normal).

**Note**

If SW4 is not switched back to pin 6 position, the password is cleared every time you power cycle the server.

- Step 11** Replace the top cover, replace the server in the rack, replace power cords and any other cables, and then power on the server by pressing the Power button.
-

## Using the Clear CMOS DIP Switch (SW4, Pins 9 - 21)

You can use this procedure to clear the server's CMOS settings in the case of a system hang. For example, if the server hangs because of incorrect settings and does not boot, use this jumper to invalidate the settings and reboot with defaults.



---

**Caution** Clearing the CMOS removes any customized settings and might result in data loss. Make a note of any necessary customized settings in the BIOS before you use this clear CMOS procedure.

---

### Procedure

---

- Step 1** Shut down and remove power from the server as described in [Shutting Down and Removing Power From the Server, on page 35](#). Disconnect power cords from all power supplies.
- Step 2** Slide the server out the front of the rack far enough so that you can remove the top cover. You might have to detach cables from the rear panel to provide clearance.
- Caution**  
If you cannot safely view and access the component, remove the server from the rack.
- Step 3** Remove the top cover from the server as described in [Removing the Server Top Cover, on page 37](#).
- Step 4** Locate SW4 DIP Switch and pins 9-21, as shown in [Service DIP Switch, Headers and Jumpers, on page 89](#).  
Default position is at pin 9 (Off: normal).
- Step 5** To clear the CMOS, switch to pin 21 position (On: clear).
- Step 6** Reinstall the top cover and reconnect AC power cords to the server. The server powers up to standby power mode, indicated when the Power LED on the front panel is amber.
- Step 7** Return the server to main power mode by pressing the Power button on the front panel. The server is in main power mode when the Power LED is green.
- Note**  
You must allow the entire server to reboot to main power mode to complete the reset. The state of the jumper cannot be determined without the host CPU running.
- Step 8** Press the Power button to shut down the server to standby power mode, and then remove AC power cords from the server to remove all power.
- Step 9** Remove the top cover from the server.
- Step 10** Switch SW4 back to pin 9 position (Off: normal).
- Note**  
If SW4 is not switched back to pin 9 position, the CMOS settings are reset to the defaults every time you power cycle the server.
- Step 11** Replace the top cover, replace the server in the rack, replace power cords and any other cables, and then power on the server by pressing the Power button.
-

## Using the Boot Alternate Cisco IMC Image Header (CN5, Pins 1 - 2)

You can use this Cisco IMC debug header to force the system to boot from an alternate Cisco IMC image.

### Procedure

---

**Step 1** Shut down and remove power from the server as described in [Shutting Down and Removing Power From the Server, on page 35](#). Disconnect power cords from all power supplies.

**Step 2** Slide the server out the front of the rack far enough so that you can remove the top cover. You might have to detach cables from the rear panel to provide clearance.

**Caution**

If you cannot safely view and access the component, remove the server from the rack.

**Step 3** Remove the top cover from the server as described in [Removing the Server Top Cover, on page 37](#).

**Step 4** Locate header block CN5, pins 1-2, as shown in [Service DIP Switch, Headers and Jumpers, on page 89](#).

**Step 5** Install a two-pin jumper across CN5 pins 1 and 2.

**Step 6** Reinstall the top cover and reconnect AC power cords to the server. The server powers up to standby power mode, indicated when the Power LED on the front panel is amber.

**Step 7** Return the server to main power mode by pressing the Power button on the front panel. The server is in main power mode when the Power LED is green.

**Note**

When you next log in to Cisco IMC, you see a message similar to the following:

```
'Boot from alternate image' debug functionality is enabled.  
CIMC will boot from alternate image on next reboot or input power cycle.
```

**Step 8** Press the Power button to shut down the server to standby power mode, and then remove AC power cords from the server to remove all power.

**Step 9** Remove the top cover from the server.

**Step 10** Remove the jumper that you installed.

**Note**

If you do not remove the jumper, the server will boot from an alternate Cisco IMC image every time that you power cycle the server or reboot Cisco IMC.

**Step 11** Replace the top cover, replace the server in the rack, replace power cords and any other cables, and then power on the server by pressing the Power button.

---

## Using the Reset Cisco IMC Password to Default Header (CN5, Pins 3 - 4)

You can use this Cisco IMC debug header to force the Cisco IMC password back to the default.

## Procedure

---

**Step 1** Shut down and remove power from the server as described in [Shutting Down and Removing Power From the Server, on page 35](#). Disconnect power cords from all power supplies.

**Step 2** Slide the server out the front of the rack far enough so that you can remove the top cover. You might have to detach cables from the rear panel to provide clearance.

**Caution**

If you cannot safely view and access the component, remove the server from the rack.

**Step 3** Remove the top cover from the server as described in [Removing the Server Top Cover, on page 37](#).

**Step 4** Locate header block CN5, pins 3-4, as shown in [Service DIP Switch, Headers and Jumpers, on page 89](#).

**Step 5** Install a two-pin jumper across CN5 pins 3 and 4.

**Step 6** Reinstall the top cover and reconnect AC power cords to the server. The server powers up to standby power mode, indicated when the Power LED on the front panel is amber.

**Step 7** Return the server to main power mode by pressing the Power button on the front panel. The server is in main power mode when the Power LED is green.

**Note**

When you next log in to Cisco IMC, you see a message similar to the following:

```
'Reset to default CIMC password' debug functionality is enabled.  
On input power cycle, CIMC password will be reset to defaults.
```

**Step 8** Press the Power button to shut down the server to standby power mode, and then remove AC power cords from the server to remove all power.

**Step 9** Remove the top cover from the server.

**Step 10** Remove the jumper that you installed.

**Note**

If you do not remove the jumper, the server will reset the Cisco IMC password to the default every time that you power cycle the server. The jumper has no effect if you reboot Cisco IMC.

**Step 11** Replace the top cover, replace the server in the rack, replace power cords and any other cables, and then power on the server by pressing the Power button.

---



## CHAPTER 4

# Recycling Server Components

---

This chapter contains the following topics:

- [Server Recycling and E-Waste](#), on page 97
- [Battery Warning](#), on page 97
- [Recycling the Main Motherboard PCB Assembly \(PCBA\)](#), on page 97
- [Recycling the Front Mezzanine Module PCBA \(SAS Backplane\)](#), on page 99
- [Recycling the Server KVM PCBA](#), on page 100

## Server Recycling and E-Waste

The server has various components that can be recycled. When recycling the server and its components, always comply with your local laws governing recycling and e-waste.



---

**Warning**

The procedures in this chapter are destructive and can render the server unusable, so this content is not for standard use or FRU procedures! These procedures are for recyclers only.

---

## Battery Warning

The server has a round button-style battery which is used for the real-time clock.



---

**Warning**

**Recyclers:** Do not shred the battery! Make sure you dispose of the battery according to appropriate regulations for your country or locale.

---

For information about removing the battery, see [Replacing the RTC Battery](#), on page 62.

## Recycling the Main Motherboard PCB Assembly (PCBA)

The PCBA is secured to the server's sheet metal. You must disconnect the PCBA from the tray before recycling the PCBA. The PCBA is secured by different types of fasteners.

## Before you begin



**Note** **For Recyclers Only!** This procedure is not a standard field-service option. This procedure is for recyclers who will be reclaiming the electronics for proper disposal to comply with local eco design and e-waste regulations.

To remove the printed circuit board assembly (PCBA), the following requirements must be met:

- The server must be disconnected from facility power.
- The server must be removed from the equipment rack.
- The server's top cover must be removed. See [Removing the Server Top Cover, on page 37](#).
- The server's fan modules must be removed. See [Replacing Fan Modules, on page 47](#).

Gather the following tools before beginning this procedure:

- Pliers
- T10 Torx screwdriver
- #2 Phillips screwdriver

## Procedure

**Step 1** Locate the PCBA's mounting screws. The following figure shows the location of the mounting screws.

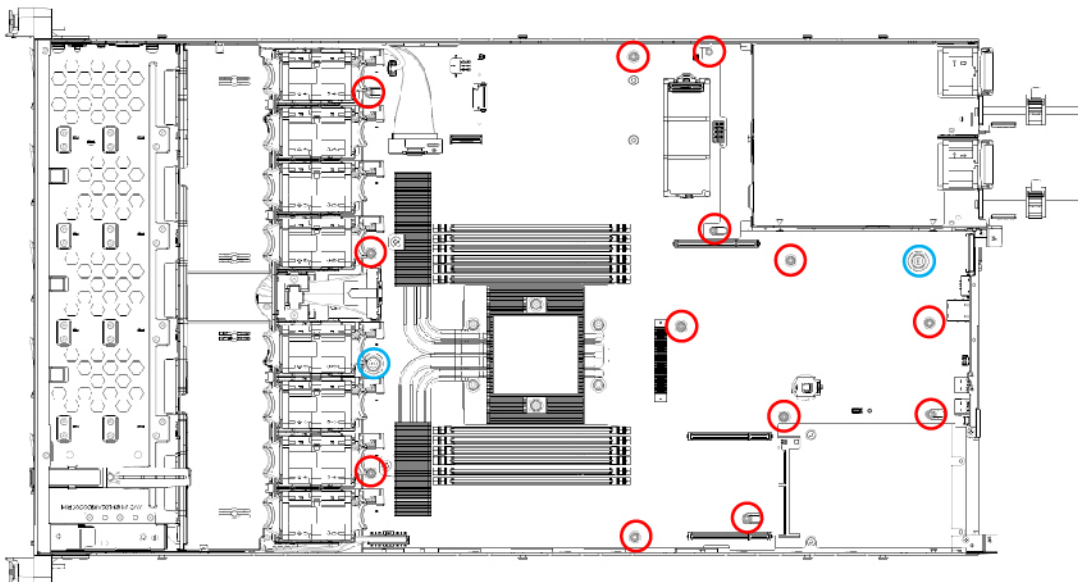

Indicator	Fastener	Required Tool
Red circles (○)	M3.5x0.6 mm screws (18)	Torx T10 - Torque: 10.0 kgf-cm (8.68 in-lbs)
Blue circles (○)	M3.5x0.6 mm Thumb screws (2)	Torx T10 - Torque: 5.0 kgf-cm (4.34 in-lbs)

**Step 2** Using the appropriate tools, remove the screws.

**Step 3** Remove the PCBA from the sheet metal and dispose of each in compliance with your local e-waste and recycling regulations.

## Recycling the Front Mezzanine Module PCBA (SAS Backplane)

The server's front mezzanine module contains one PCBA, which is the vertical PCB for the SAS drive backplane. The PCBA is attached to the server's sheetmetal by 4 T10 screws.

You must disconnect the PCBA from the sheetmetal before recycling the PCBA.

### Before you begin



**Note** **For Recyclers Only!** This procedure is not a standard field-service option. This procedure is for recyclers who will be reclaiming the electronics for proper disposal to comply with local eco design and e-waste regulations.

To remove the printed circuit board assembly (PCBA), the following requirements must be met:

- The server must be disconnected from facility power.
- The server must be removed from the equipment rack.
- The server's top cover must be removed. See [Removing the Server Top Cover, on page 37](#).
- The server's fan modules must be removed. See [Replacing Fan Modules, on page 47](#).
- The front-loading drives must be removed. See [Replacing a SAS/SATA Drive, on page 43](#).

Gather a T10 Torx screwdriver.

### Procedure

**Step 1** Disconnect the vertical drive backplane.

- a) Using a T10 Torx driver, remove the four screws of the vertical drive backplane.
- b) Grasp the drive backplane and disconnect it from the sheetmetal frame.

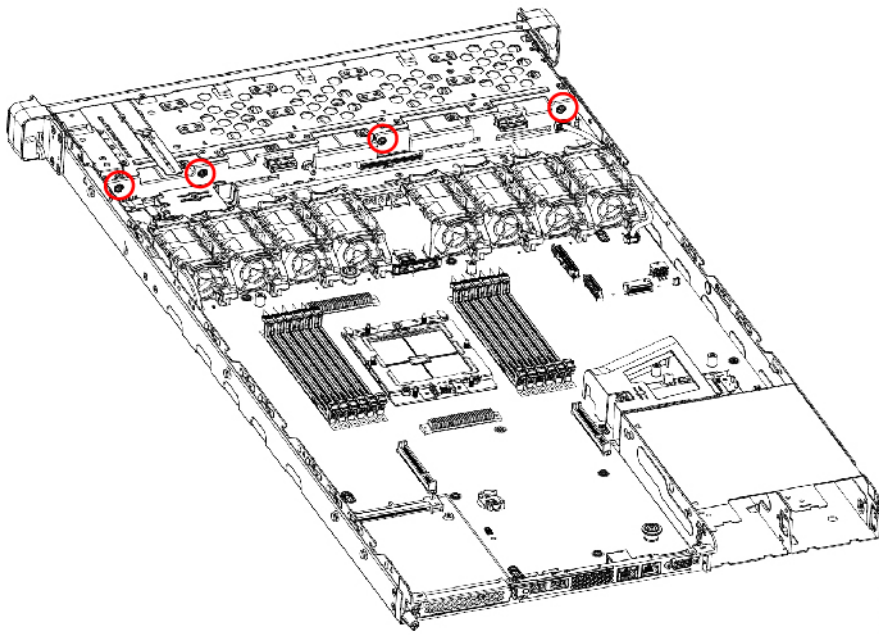

**Step 2** Disconnect the PCBA from the sheetmetal frame.

- a) Using a T10 Torx screwdriver, remove the four screws that secure the PCBA to the sheetmetal frame.



**Step 3** Remove the PCBA and dispose of it properly in accordance with your local recycling and e-waste laws.

## Recycling the Server KVM PCBA

The server contains a KVM port, which is vertically mounted in the front right mounting ear. The KVM has a small PCB attached to a flat ribbon cable.

- Two size 2.5 slotted screws on the face of the tray.
- One #1 Phillips-head screw.
- One T10 Torx screws that secure the PCBA to the interior of the tray.

You must disconnect the PCBA from the server before recycling the PCBA.

### Before you begin



**Note** **For Recyclers Only!** This procedure is not a standard field-service option. This procedure is for recyclers who will be reclaiming the electronics for proper disposal to comply with local eco design and e-waste regulations.

To remove the printed circuit board assembly (PCBA), the following requirements must be met:

- The server must be disconnected from facility power.
- The server must be removed from the equipment rack.
- The server's top cover must be removed. See [Removing the Server Top Cover, on page 37](#).

Gather the following tools:

- A size 2.5 slotted screwdriver.
- A #1 Phillips screwdriver
- A T10 Torx screwdriver.

### Procedure

**Step 1** Disconnect the KVM port from the front panel.

- a) Using a 2.5 Phillips screwdriver, remove the two screws on the face of the front panel.

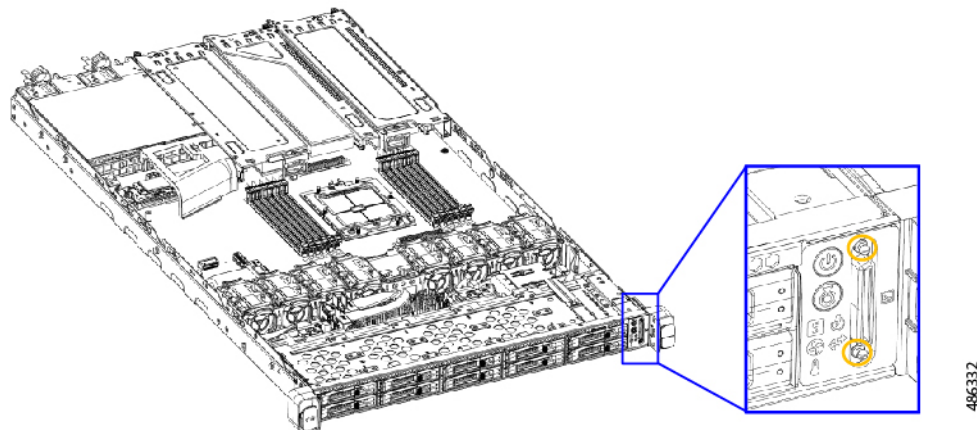

- b) On the back of the front panel, use a #1 Phillips head screwdriver to remove the 1 screw that secures the KVM port to the front panel.

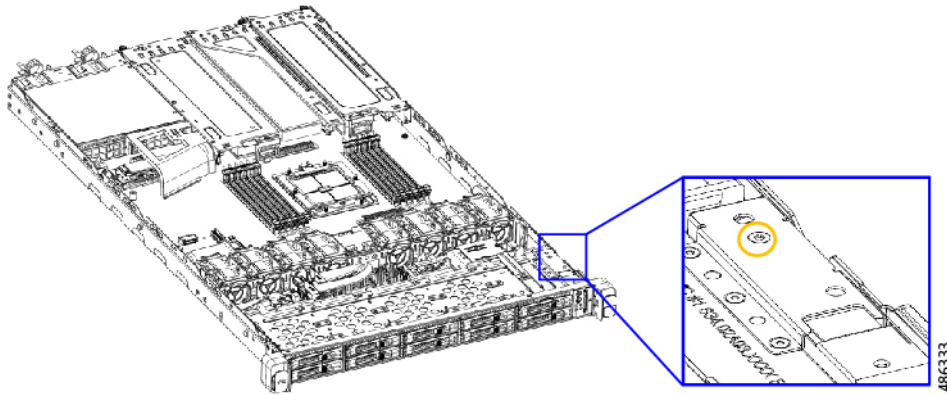

- c) On the side of the chassis, use a T10 Torx driver to remove the one T10 screw.
- d) Grasp the side trim piece and remove it.

**Step 2** Remove the screws on the KVM board.

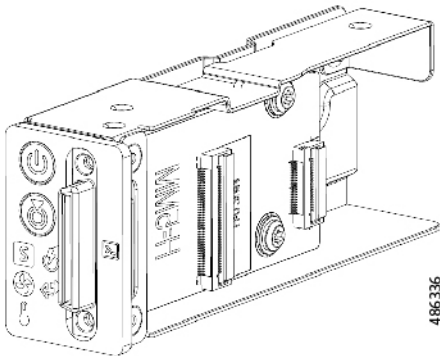

**Step 3** Remove the PCBA and dispose of it properly in accordance with your local recycling and e-waste laws.



# APPENDIX A

## Server Specifications

- [Physical Specifications](#), on page 103
- [Environmental Specifications](#), on page 103
- [Power Specifications](#), on page 105
- [Power Cord Specifications](#), on page 108

## Physical Specifications

The following table lists the physical specifications for the server.

**Table 11: Physical Specifications**

Description	Specification
Height	1.7 in. (43.2 mm)
Width	16.9 in. (429.0 mm)
Depth (length)	Server only: 30 in. (762 mm) Server with slide rail: 31.5 in (800.1 mm)
Weight	<ul style="list-style-type: none"><li>• Maximum, fully configured with rail kit: 42.43 lb (19.30 kg)</li><li>• Minimum with 1 HDD, 1 CPU, 1DIMM, and 1 1600 W PSU, no rail kit: 22.32 lb (10.13 kg)</li></ul>

## Environmental Specifications

The following table lists the environmental requirements and specifications for the server.

**Table 12: Physical Specifications**

Description	Specification
-------------	---------------

Temperature, Operating	<p>10° C to 35° C (50° F to 95° F) with no direct sunlight</p> <p>Derate the maximum temperature by 1° C per every 300 meters of altitude above sea level.</p> <p><b>Note</b> Although the ASHRAE guidelines define multiple classes with different operating ranges, the <i>recommended</i> temperature and humidity operating range is the same for each class. The <i>recommended</i> temperature and humidity ranges are:</p> <ul style="list-style-type: none"> <li>• Operating Temperature: 64.4°F to 80.6°F (18°C to 27°C)</li> </ul> <p>For general information, see the <a href="#">Cisco Unified Computing System Site Planning Guide: Data Center Power and Cooling</a>.</p>
Temperature, non-operating (when the server is stored or transported)	<p>Below -40° C or above 65° C (below -40° F or above 149° F)</p> <p>Maximum rate of change (operating and non-operating) 20° C/hr (36° F/hr)</p>
Extended Operating Temperature	<p>5° C to 40° C (41° F to 104° F) with no direct sunlight</p> <p>Maximum allowable operating temperature derated 1° C/175 m (1° F/319 ft) above 950 m (3117 ft)</p> <p>5° C to 45° C (41° F to 113° F) with no direct sunlight</p> <p>Maximum allowable operating temperature derated 1° C/125 m (1° F/228 ft) above 950 m (3117 ft)</p> <p>System performance may be impacted when operating in the extended operating temperature range.</p> <p>Operation above 40° C is limited to less than 1% of annual operating hours.</p> <p>Hardware configuration limits apply to extended operating temperature range.</p>
Humidity (RH), operating	8 to 90% and 24° C (75o F) maximum dew-point temperature, non-condensing environment
Humidity (RH), non-operating (when the server is stored or transported)	Below 5% or above 95% and 33o C (91o F) maximum dew-point temperature, non-condensing environment
Altitude, operating	0 to 10,000 feet
Altitude, non-operating (when the server is stored or transported)	0 to 40,000 feet
Sound power level Measure A-weighted per ISO7779 LwAd (Bels) Operation at 73°F (23°C)	5.8

Sound pressure level Measure A-weighted per ISO7779 LpAm (dBA) Operation at 73°F (23°C)	43
---	----

## Power Specifications



**Note** Do not mix power supply types or wattages in the server. Both power supplies must be identical.

You can get more specific power information for your exact server configuration by using the Cisco UCS Power Calculator:

<http://ucspowercalc.cisco.com>

The power specifications for the supported power supply options are listed in the following sections.

### 1050 W DC Power Supply

This section lists the specifications for each 1050 W DC power supply (Cisco part number UCSC-PSUV2-1050DC).

**Table 13: 1050 W DC Specifications**

Description	Specification
DC Input Voltage	Nominal range: -48 to -60 VDC (Range: -40 to -72 VDC)
Maximum DC input current	32 A at -40 VDC
Maximum input wattage	1234 W
Maximum inrush current	35 A (sub-cycle duration)
Maximum hold-up time	5 ms at 100% load (1050 W main and 36 W standby)
Maximum output power per PSU	1050 W on 12 VDC main power 36 W on 12 VDC standby power
Power supply output voltage	12 VDC
Power supply standby voltage	12 VDC
Efficiency rating	≥ 92% at 50% load
Form factor	RSP2
Input connector	Fixed 3-wire block

## 1200 W AC Power Supply

This section lists the specifications for each 1050 W AC power supply (Cisco part number UCSC-PSU1-1200W-D).

**Table 14: 1200 W AC Specifications**

Description	Specification
AC input voltage	Range: 100–230 VAC
AC input frequency	Range: 50 to 60Hz
Maximum AC input current	12.97 A at 100 VAC
Maximum input volt-amperes	1345 VA at 208 VAC
Maximum inrush current	20 A
Maximum hold-up time	12 ms at 1200 W
Maximum output power per PSU	1100 W at 100–120 VAC 1200 W at 208–230 VAC
Power supply output voltage	12 VDC
Power supply standby voltage	12 VDC
Efficiency rating	Climate Savers Platinum Efficiency (80Plus Titanium certified)
Form factor	RSP2
Input connector	IEC320 C14

## 1600 W AC Power Supply

This section lists the specifications for each 1600 W AC power supply (Cisco part number UCSC-PSU1-1600W).

**Table 15: 1600 W AC Specifications**

Description	Specification
AC Input Voltage	Nominal range: 200–240 VAC (Range: 180–264 VAC)
AC Input Frequency	Nominal range: 50 to 60Hz (Range: 47–63 Hz)
Maximum AC Input current	9.5 A at 200 VAC
Maximum input volt-amperes	1250 VA at 200 VAC

Maximum inrush current	30 A at 35° C
Maximum hold-up time	80 ms at 1600 W
Maximum output power per PSU	1600 W at 200–240 VAC
Power supply output voltage	12 VDC
Power supply standby voltage	12 VDC
Efficiency rating	Climate Savers Platinum Efficiency (80Plus Platinum certified)
Form factor	RSP2
Input connector	IEC320 C14

## 2300 W AC Power Supply

This section lists the specifications for each 2300 W AC power supply (Cisco part number UCSC-PSU1-2300).

**Table 16: 2300 W AC Specifications**

Description	Specification
AC Input Voltage	Nominal range: 100–230 VAC (Range: 90–264 VAC)
AC Input Frequency	Nominal range: 50 to 60Hz (Range: 47–63 Hz)
Maximum AC Input current	13 A at 100 VAC
Maximum input volt-amperes	2515 VA at 208 VAC
Maximum inrush current	30 A at 35° C
Maximum hold-up time	80 ms at 1600 W
Maximum output power per PSU	2300W at 220-240V input and 1200W at 110-120V
Power supply output voltage	12 VDC
Power supply standby voltage	12 VDC
Efficiency rating	Climate Savers Platinum Efficiency (80Plus Platinum certified)
Form factor	RSP2
Input connector	IEC320 C20

## Power Cord Specifications

Each power supply in the server has a power cord. Standard power cords or jumper power cords are available for connection to the server. The shorter jumper power cords, for use in racks, are available as an optional alternative to the standard power cords.



**Note** Only the approved power cords or jumper power cords listed below are supported.

**Table 17: Supported Power Cords**

Description	Length (Feet)	Length (Meters)
CAB-48DC-40A-8AWG DC power cord, -48 VDC, 40 A, 8 AWG Three-socket Mini-Fit connector to three-wire	11.7	3.5
CAB-C13-C14-AC AC power cord, 10 A; C13 to C14, recessed receptacle	9.8	3.0
CAB-250V-10A-AR AC power cord, 250 V, 10 A Argentina	8.2	2.5
CAB-C13-C14-2M-JP AC Power Cord, C13 to C14 Japan PSE Mark	6.6	2.0
CAB-9K10A-EU AC Power Cord, 250 V, 10 A; CEE 7/7 Plug Europe	8.2	2.5
CAB-250V-10A-IS AC Power Cord, 250 V, 10 A Israel	8.2	2.5
CAB-250V-10A-CN AC power cord, 250 V, 10 A PR China	8.2	2.5
CAB-ACTW AC power cord, 250 V, 10 A Taiwan	7.5	2.3

CAB-C13-CBN AC cabinet jumper power cord, 250, 10 A, C13 to C14	2.2	0.68
CAB-C13-C14-2M AC cabinet jumper power cord, 250 V, 10 A, C13 to C14	6.6	2.0
CAB-9K10A-AU AC power cord, 250 V, 10 A, 3112 plug, Australia	8.2	2.5
CAB-N5K6A-NA AC power cord, 200/240 V, 6 A, North America	8.2	2.5
CAB-250V-10A-ID AC power Cord, 250 V, 10 A, India	8.2	2.5
CAB-9K10A-SW AC power cord, 250 V, 10 A, MP232 plug Switzerland	8.2	2.5
CAB-250V-10A-BR AC power Cord, 250 V, 10 A Brazil	8.2	2.5
CAB-9K10A-UK AC power cord, 250 V, 10 A (13 A fuse), BS1363 plug United Kingdom	8.2	2.5
CAB-9K12A-NA AC power cord, 125 V, 13 A, NEMA 5-15 plug North America	8.2	2.5
CAB-AC-L620-C13 AC power cord, NEMA L6-20 to C13 connectors	6.6	2.0
CAB-9K10A-IT AC power cord, 250 V, 10 A, CEI 23-16/VII plug Italy	8.2	2.5

R2XX-DMYMPWRCORD No power cord; PID option for ordering server with no power cord	NA	NA
--	----	----



## APPENDIX **B**

# Installation For Cisco UCS Manager Integration

---

- [Installation For Cisco UCS Manager Integration, on page 111](#)

## Installation For Cisco UCS Manager Integration

The Cisco UCS Manager integration instructions are in the integration guides found here:

[Cisco UCS C-Series Server Integration with UCS Manager Configuration Guides](#)

Refer to the guide that is for the version of Cisco UCS Manager that you are using.

Also refer to the release notes for Cisco UCS Manager software and C-Series Cisco IMC software for any special considerations regarding integration in your release.

- [Cisco UCS Manager Release Notes](#)
- [Cisco C-Series Software Release Notes](#)





## APPENDIX **C**

# GPU Installation

---

This appendix has the following topics:

- [Server Firmware Requirements, on page 113](#)
- [GPU Card Configuration Rules, on page 113](#)
- [Requirement For All GPUs: Memory-Mapped I/O Greater Than 4 GB, on page 114](#)
- [Installing a Single-Wide GPU Card, on page 114](#)
- [Using NVIDIA GRID License Server For L-Series GPUs, on page 115](#)

## Server Firmware Requirements

The following table lists the minimum server firmware versions for the supported GPU cards.

GPU Card	Cisco IMC/BIOS Minimum Version Required
NVIDIA L4 PCIe, 72W, Gen 4 x8 (UCSC-GPU-L4)	4.1(3)

## GPU Card Configuration Rules

Note the following rules when populating a server with GPU cards.

- Use the UCS power calculator at the following link to determine the power needed based on your server configuration: <http://ucspowercalc.cisco.com>
- Do not mix different brands or models of GPU cards in the server.
- A GPU can be installed in any PCIe riser slot.
- Some GPUs have a limitation on whether they can support 1 TB or more memory in the server.

# Requirement For All GPUs: Memory-Mapped I/O Greater Than 4 GB

All supported GPU cards require enablement of the BIOS setting that allows greater than 4 GB of memory-mapped I/O (MMIO).

In standalone mode, BIOS setting is enabled by default:

**Advanced > PCI Configuration > Memory Mapped I/O Above 4 GB > Enabled**

## Procedure

---

- Step 1** If you need to change this setting, enter the BIOS Setup Utility by pressing **F2** when prompted during bootup.
- Step 2** Browse to **Advanced > PCI Configuration > Memory Mapped I/O Above 4 GB**.
- 

## Installing a Single-Wide GPU Card

Use the following procedure to install or replace the following supported single-wide GPU cards:

- NVIDIA L4 PCIe, 72W

## Procedure

---

- Step 1** Shut down and remove power from the server as described in [Shutting Down and Removing Power From the Server, on page 35](#).
- Step 2** Slide the server out the front of the rack far enough so that you can remove the top cover. You might have to detach cables from the rear panel to provide clearance.
- Caution**  
If you cannot safely view and access the component, remove the server from the rack.
- Step 3** Remove the top cover from the server as described in [Removing the Server Top Cover, on page 37](#).
- Step 4** Refer [Replacing a PCIe Card, on page 73](#) to replace single-wide GPU card.
- Step 5** Replace the top cover to the server.
- Step 6** Replace the server in the rack, replace cables, and then fully power on the server by pressing the Power button.
- Step 7** Optional: Continue with [Installing Drivers to Support the GPU Cards, on page 121](#).

### Note

If you installed an NVIDIA Tesla M-series or P-Series GPU, you must install GRID licenses to use the GRID features. See [Using NVIDIA GRID License Server For L-Series GPUs, on page 115](#).

---

# Using NVIDIA GRID License Server For L-Series GPUs

This section applies to NVIDIA L-Series GPUs.

Use the topics in this section in the following order when obtaining and using NVIDIA GRID licenses.

1. Familiarize yourself with the NVIDIA GRID License Server.

[NVIDIA GRID License Server Overview, on page 115](#)

2. Register your product activation keys with NVIDIA.

[Registering Your Product Activation Keys With NVIDIA, on page 117](#)

3. Download the GRID software suite.

[Downloading the GRID Software Suite, on page 116](#)

4. Install the GRID License Server software to a host.

[Installing NVIDIA GRID License Server Software, on page 117](#)

5. Generate licenses on the NVIDIA Licensing Portal and download them.

[Installing GRID Licenses From the NVIDIA Licensing Portal to the License Server, on page 118](#)

6. Manage your GRID licenses.

[Managing GRID Licenses , on page 119](#)

## NVIDIA GRID License Server Overview

The NVIDIA M-Series GPUs combine Tesla and GRID functionality when the licensed GRID features such as GRID vGPU and GRID Virtual Workstation are enabled. These features are enabled during OS boot by borrowing a software license that is served over the network from the NVIDIA GRID License Server virtual appliance. The license is returned to the license server when the OS shuts down.

You obtain the licenses that are served by the GRID License Server from NVIDIA's Licensing Portal as downloadable license files, which you install into the GRID License Server via its management interface.

Figure 41: NVIDIA GRID Licensing Architecture

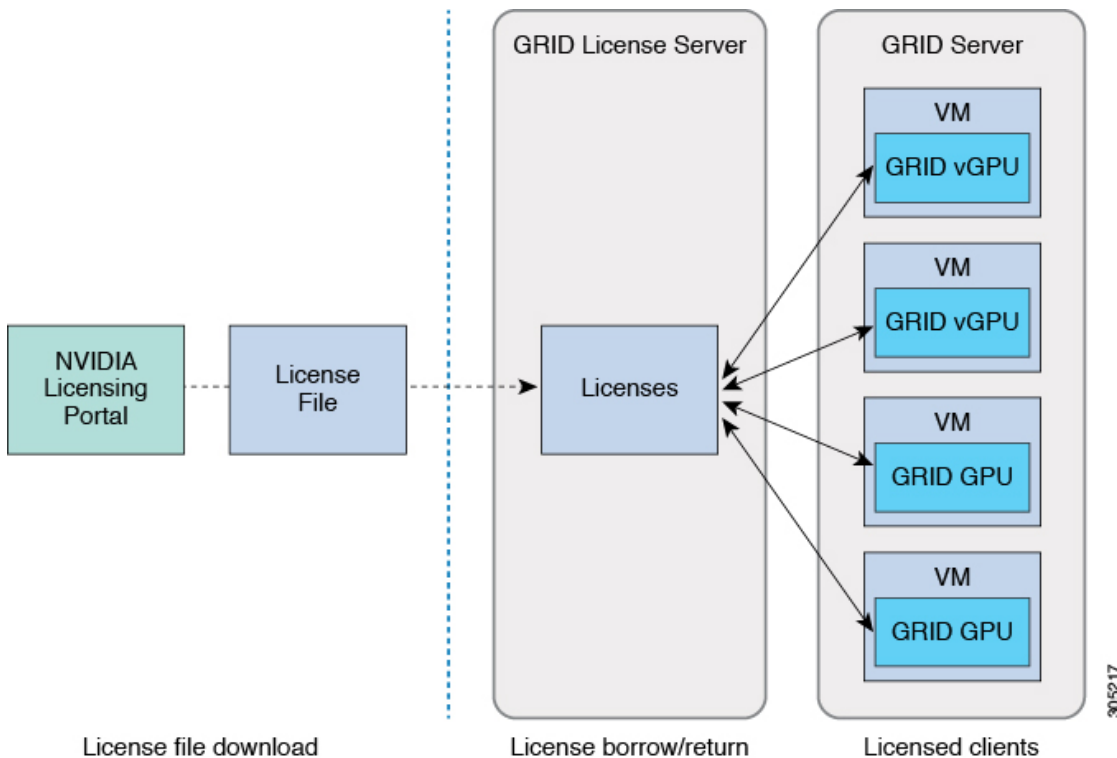

There are three editions of GRID licenses, which enable three different classes of GRID features. The GRID software automatically selects the license edition based on the features that you are using.

GRID License Edition	GRID Feature
GRID Virtual GPU (vGPU)	Virtual GPUs for business desktop computing
GRID Virtual Workstation	Virtual GPUs for midrange workstation computing
GRID Virtual Workstation – Extended	Virtual GPUs for high-end workstation computing Workstation graphics on GPU pass-through

## Downloading the GRID Software Suite

### Procedure

- 
- Step 1** Return to the NVIDIA Software Licensing Center > Product Information Software dialog.
- Step 2** Click the **Current Releases** tab.
- Step 3** Click the **NVIDIA GRID** link to access the Product Download dialog. This dialog includes download links for:
- NVIDIA License Manager software

- The gpumodeswitch utility
- The host driver software

**Step 4** Use the links to download the software.

---

## Registering Your Product Activation Keys With NVIDIA

After your order is processed, NVIDIA sends you a Welcome email that contains your product activation keys (PAKs) and a list of the types and quantities of licenses that you purchased.

### Procedure

---

- Step 1** Select the **Log In** link, or the **Register** link if you do not already have an account.  
The NVIDIA Software Licensing Center > License Key Registration dialog opens.
- Step 2** Complete the License Key Registration form and then click **Submit My Registration Information**.  
The NVIDIA Software Licensing Center > Product Information Software dialog opens.
- Step 3** If you have additional PAKs, click **Register Additional Keys**. For each additional key, complete the form on the License Key Registration dialog and then click **Submit My Registration Information**.
- Step 4** Agree to the terms and conditions and set a password when prompted.
- 

## Installing NVIDIA GRID License Server Software

For full installation instructions and troubleshooting, refer to the *NVIDIA GRID License Server User Guide*. Also refer to the *NVIDIA GRID License Server Release Notes* for the latest information about your release.

<http://www.nvidia.com>

### Platform Requirements for NVIDIA GRID License Server

- The hosting platform can be a physical or a virtual machine. NVIDIA recommends using a host that is dedicated only to running the License Server.
- The hosting platform must run a supported Windows OS.
- The hosting platform must have a constant IP address.
- The hosting platform must have at least one constant Ethernet MAC address.
- The hosting platform's date and time must be set accurately.

# Installing GRID Licenses From the NVIDIA Licensing Portal to the License Server

## Accessing the GRID License Server Management Interface

Open a web browser on the License Server host and access the URL <http://localhost:8080/licserver>.

If you configured the License Server host's firewall to permit remote access to the License Server, the management interface is accessible from remote machines at the URL <http://hostname:8080/licserver>

## Reading Your License Server's MAC Address

Your License Server's Ethernet MAC address is used as an identifier when registering the License Server with NVIDIA's Licensing Portal.

### Procedure

---

**Step 1** Access the GRID License Server Management Interface in a browser.

**Step 2** In the left-side License Server panel, select **Configuration**.

The License Server Configuration panel opens. Next to **Server host ID**, a pull-down menu lists the possible Ethernet MAC addresses.

**Step 3** Select your License Server's MAC address from the **Server host ID** pull-down.

#### Note

It is important to use the same Ethernet ID consistently to identify the server when generating licenses on NVIDIA's Licensing Portal. NVIDIA recommends that you select one entry for a primary, non-removable Ethernet interface on the platform.

---

## Installing Licenses From the Licensing Portal

### Procedure

---

**Step 1** Access the GRID License Server Management Interface in a browser.

**Step 2** In the left-side License Server panel, select **Configuration**.

The License Server Configuration panel opens.

**Step 3** Use the License Server Configuration menu to install the .bin file that you generated earlier.

- a) Click **Choose File**.
- b) Browse to the license .bin file that you want to install and click **Open**.
- c) Click **Upload**.

The license file is installed on your License Server. When installation is complete, you see the confirmation message, “Successfully applied license file to license server.”

---

## Viewing Available GRID Licenses

Use the following procedure to view which licenses are installed and available, along with their properties.

### Procedure

- 
- Step 1** Access the GRID License Server Management Interface in a browser.
  - Step 2** In the left-side License Server panel, select **Licensed Feature Usage**.
  - Step 3** Click on a feature in the **Feature** column to see detailed information about the current usage of that feature.
- 

## Viewing Current License Usage

Use the following procedure to view information about which licenses are currently in-use and borrowed from the server.

### Procedure

- 
- Step 1** Access the GRID License Server Management Interface in a browser.
  - Step 2** In the left-side License Server panel, select **Licensed Clients**.
  - Step 3** To view detailed information about a single licensed client, click on its **Client ID** in the list.
- 

## Managing GRID Licenses

Features that require GRID licensing run at reduced capability until a GRID license is acquired.

## Acquiring a GRID License on Windows

### Procedure

- 
- Step 1** Open the NVIDIA Control Panel using one of the following methods:
    - Right-click on the Windows desktop and select **NVIDIA Control Panel** from the menu.
    - Open Windows Control Panel and double-click the **NVIDIA Control Panel** icon.
  - Step 2** In the NVIDIA Control Panel left-pane under Licensing, select **Manage License**.

The Manage License task pane opens and shows the current license edition being used. The GRID software automatically selects the license edition based on the features that you are using. The default is Tesla (unlicensed).

- Step 3** If you want to acquire a license for GRID Virtual Workstation, under License Edition, select **GRID Virtual Workstation**.
- Step 4** In the **License Server** field, enter the address of your local GRID License Server. The address can be a domain name or an IP address.
- Step 5** In the **Port Number** field, enter your port number or leave it set to the default used by the server, which is 7070.
- Step 6** Select **Apply**.

The system requests the appropriate license edition from your configured License Server. After a license is successfully acquired, the features of that license edition are enabled.

**Note**

After you configure licensing settings in the NVIDIA Control Panel, the settings persist across reboots.

## Acquiring a GRID License on Linux

### Procedure

- Step 1** Edit the configuration file `/etc/nvidia/gridd.conf`:
- ```
sudo vi /etc/nvidia/gridd.conf
```
- Step 2** Edit the Server URL line with the address of your local GRID License Server.  
The address can be a domain name or an IP address. See the example file below.
- Step 3** Append the port number (default 7070) to the end of the address with a colon. See the example file below.
- Step 4** Edit the FeatureType line with the integer for the license type. See the example file below.
- GRID vGPU = 1
  - GRID Virtual Workstation = 2
- Step 5** Restart the `nvidia-gridd` service.
- ```
sudo service nvidia-gridd restart
```
- The service automatically acquires the license edition that you specified in the FeatureType line. You can confirm this in `/var/log/messages`.
- Note**  
After you configure licensing settings in the NVIDIA Control Panel, the settings persist across reboots.

Sample configuration file:

```
# /etc/nvidia/gridd.conf - Configuration file for NVIDIA Grid Daemon
# Description: Set License Server URL
# Data type: string
# Format: "<address>:<port>"
ServerUrl=10.31.20.45:7070
```

```
# Description: Set Feature to be enabled
# Data type: integer
# Possible values:
# 1 => for GRID vGPU
# 2 => for GRID Virtual Workstation
FeatureType=2
```

---

## Using gpumodeswitch

The command line utility `gpumodeswitch` can be run in the following environments:

- Windows 64-bit command prompt (requires administrator permissions)
- Linux 32/64-bit shell (including Citrix XenServer dom0) (requires root permissions)



---

**Note** Consult NVIDIA product release notes for the latest information on compatibility with compute and graphic modes.

---

The `gpumodeswitch` utility supports the following commands:

- `--listgpumodes`

Writes information to a log file named `listgpumodes.txt` in the current working directory.

- `--gpumode graphics`

Switches to graphics mode. Switches mode of all supported GPUs in the server unless you specify otherwise when prompted.

- `--gpumode compute`

Switches to compute mode. Switches mode of all supported GPUs in the server unless you specify otherwise when prompted.



---

**Note** After you switch GPU mode, reboot the server to ensure that the modified resources of the GPU are correctly accounted for by any OS or hypervisor running on the server.

---

## Installing Drivers to Support the GPU Cards

After you install the hardware, you must update to the correct level of server BIOS and then install GPU drivers and other software in this order:

1. Update the server BIOS.
2. Update the GPU drivers.

## 1. Updating the Server BIOS

Install the latest BIOS by using the Host Upgrade Utility.



---

**Note** You must do this procedure before you update the NVIDIA drivers.

---

### Procedure

---

- Step 1** Navigate to the following URL: <http://www.cisco.com/cisco/software/navigator.html>.
- Step 2** Click **Servers–Unified Computing** in the middle column.
- Step 3** Click **Cisco UCS C-Series Rack-Mount Standalone Server Software** in the right-hand column.
- Step 4** Click the name of your model of server in the right-hand column.
- Step 5** Click **Unified Computing System (UCS) Server Firmware**.
- Step 6** Click the release number.
- Step 7** Click **Download Now** to download the `ucs-server_platform-huu-version_number.iso` file.
- Step 8** Verify the information on the next page, and then click **Proceed With Download**.
- Step 9** Continue through the subsequent screens to accept the license agreement and browse to a location where you want to save the file.
- Step 10** Use the Host Upgrade Utility to update the server BIOS.
- The user guides for the Host Upgrade Utility are at [Utility User Guides](#).
- 

## 2. Updating the GPU Card Drivers

After you update the server BIOS, you can install GPU drivers to your hypervisor virtual machine.

### Procedure

---

- Step 1** Install your hypervisor software on a computer. Refer to your hypervisor documentation for the installation instructions.
- Step 2** Create a virtual machine in your hypervisor. Refer to your hypervisor documentation for instructions.
- Step 3** Install the GPU drivers to the virtual machine. Download the drivers from either:
- NVIDIA Enterprise Portal for GRID hypervisor downloads (requires NVIDIA login): <https://nvidia.flexnetoperations.com/>
  - NVIDIA public driver area: <http://www.nvidia.com/Download/index.aspx>
  - AMD: <http://support.amd.com/en-us/download>
- Step 4** Restart the server.

**Step 5** Check that the virtual machine is able to recognize the GPU card. In Windows, use the Device Manager and look under Display Adapters.

---





## APPENDIX **D**

# Storage Controller Considerations

---

- [Storage Controller Cable Connectors and Backplanes, on page 125](#)

## Storage Controller Cable Connectors and Backplanes

This section describes cabling for the storage controllers and backplanes. The SAS/SATA cables are factory-installed and are used for all supported internal controllers.

This section also contains diagrams that show the cable-to-drive mapping.

### **Cisco 24G Modular SAS RAID Controller or HBA For Up To 10 Drives (UCSC-RAID-HP, UCSC-RAID-M1L16, UCSC-HBA-M1L16)**

These controller are supported 10-Drives SSD server version.

This HW RAID or HBA option can control up to 10 front-loading SAS/SATA drives in this server version.



---

**Note** Front NVMe drives are not managed by the RAID controllers.

---

1. Server supports one Cisco M8 24G SAS RAID or Cisco M8 24G SAS HBA Controller that connects to the mother board.
  - Front-loading drive bays 1—10 support 2.5-inch SAS/SATA drives
  - Optionally, front-loading drive bays 1 to 4 support 2.5-inch NVMe SSDs (with optional front NVMe cables). These are not managed by the controller.Drives 1 and 2 connect to NVMe connector A. Drives 3 and 4 connect to NVMe connector B.

Figure 42: Cisco UCS C225 M8 Block Diagram with Cisco M8 24G SAS RAID or Cisco M8 24G SAS HBA Controller

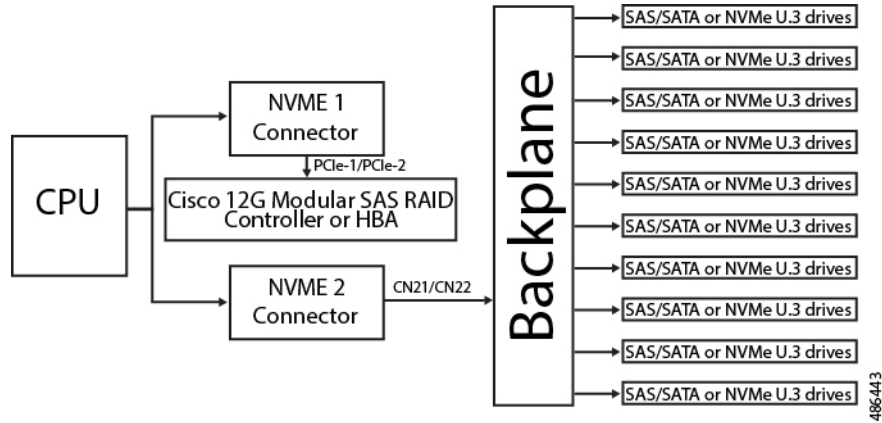

2. Server supports all NVMe drive version.

- Front-loading drive bays 1—10 support 2.5-inch SAS/SATA or NVMe U.3 drives connected to backplane.

Figure 43: Cisco UCS C225 M8 Block Diagram without RAID Controller

