



Maintenance and Service Guide

HP OmniBook X 14 inch Laptop AI PC

Model numbers: 14-fe0xxx

SUMMARY

This guide provides information about spare parts, removal and replacement of parts, security, backing up, and more.

© Copyright 2024 HP Development Company, L.P.

Bluetooth is a trademark owned by its proprietor and used by HP Inc. under license. Microsoft and Windows are either registered trademarks or trademarks of Microsoft Corporation in the United States and/or other countries. Qualcomm is a trademark of Qualcomm Incorporated, registered in the United States and other countries, used with permission. USB Type-C and USB-C® are registered trademarks of USB Implementers Forum. DisplayPort™ and the DisplayPort™ logo are trademarks owned by the Video Electronics Standards Association (VESA) in the United States and other countries. Miracast® and Wi-Fi are registered trademarks of Wi-Fi Alliance.

The information contained herein is subject to change without notice. The only warranties for HP products and services are set forth in the express warranty statements accompanying such products and services. Nothing herein should be construed as constituting an additional warranty. HP shall not be liable for technical or editorial errors or omissions contained herein.

First Edition: May 2024

Document Part Number: P01416-001

Product notice

This guide describes features that are common to most products. Some features might not be available on your computer.

Not all features are available in all editions or versions of Windows. Systems might require upgraded and/or separately purchased hardware, drivers, software, or BIOS update to take full advantage of Windows functionality. Windows is automatically updated, which is always enabled. High-speed internet and Microsoft account required. ISP fees might apply and additional requirements might apply over time for updates. See <http://www.windows.com>. **If your product ships with Windows in S Mode:** Windows in S Mode works exclusively with apps from the Microsoft Store within Windows. Certain default settings, features, and apps cannot be changed. Some accessories and apps that are compatible with Windows might not work (including some antivirus, PDF writers, driver utilities, and accessibility apps), and performance might vary, even if you switch out of S Mode. If you switch to Windows, you cannot switch back to S Mode. Learn more at [Windows.com/SmodeFAQ](https://www.windows.com/SmodeFAQ).

To access the latest user guides, go to <http://www.hp.com/support>, and follow the instructions to find your product. Then select **Setup & User Guides**.

To help us improve this document, please send any suggestions, comments, or errors to <mailto:hp.doc.feedback@hp.com>. Include the document part number when submitting your feedback.

Software Terms

By installing, copying, downloading, or otherwise using any software product preinstalled on this computer, you agree to be bound by the terms of the HP End User License Agreement (EULA). If you do not accept these license terms, your sole remedy is to return the entire unused product (hardware and software) within 14 days for a full refund subject to the refund policy of your seller.

For any further information or to request a full refund of the price of the computer, please contact your seller.

Safety warning notice

Reduce the possibility of heat-related injuries or of overheating the computer by following the practices described.

-
- ⚠ WARNING!** To reduce the possibility of heat-related injuries or of overheating the computer, do not place the computer directly on your lap or obstruct the computer air vents. Use the computer only on a hard, flat surface. Do not allow another hard surface, such as an adjoining optional printer, or a soft surface, such as pillows or rugs or clothing, to block airflow. Also, do not allow the AC adapter to come into contact with the skin or a soft surface, such as pillows or rugs or clothing, during operation. The computer and the AC adapter provided by HP comply with the user-accessible surface temperature limits defined by applicable safety standards.
-

Table of contents

1 Product description	1
2 Getting to know your computer	4
Right side	4
Left side	4
Display	6
Low blue light mode (select products only)	6
Wake-on-voice (select products only)	6
Keyboard area	7
Touchpad settings and components	7
Touchpad settings	7
Adjusting touchpad settings	7
Turning on the touchpad	8
Touchpad components	8
Lights	8
Special keys	9
Bottom	11
Labels	12
3 Illustrated parts catalog	13
Computer major components	13
Miscellaneous parts	15
4 Removal and replacement procedures preliminary requirements	16
Tools required	16
Service considerations	16
Plastic parts	16
Cables and connectors	16
Drive handling	16
Electrostatic discharge information	17
Generating static electricity	17
Preventing electrostatic damage to equipment	18
Personal grounding methods and equipment	18
Grounding the work area	19
Recommended materials and equipment	19
Cleaning your computer	20
Enabling HP Easy Clean (select products only)	20
Removing dirt and debris from your computer	20
Cleaning your computer with a disinfectant	21
Caring for wood veneer (select products only)	22
Packaging and transporting guidelines	22

Accessing support information	23
5 Removal and replacement procedures for authorized service provider parts.....	25
Component replacement procedures	25
Preparation for disassembly.....	25
Bottom cover	25
Battery.....	26
Solid-state drive.....	28
Speakers.....	30
RJ-45/audio board.....	30
Touchpad	32
System board protective cover	33
Fan.....	34
WLAN module.....	35
Heat sink	38
System board	39
Display assembly.....	41
Top cover with keyboard	47
6 Using Setup Utility (BIOS).....	49
Starting Setup Utility (BIOS).....	49
Updating Setup Utility (BIOS).....	49
Determining the BIOS version.....	49
Preparing for a BIOS update	50
Downloading a BIOS update	50
Installing a BIOS update	50
7 Backing up, restoring, and recovering.....	52
Backing up information and creating recovery media.....	52
Using Windows tools for backing up.....	52
Using the HP Cloud Recovery Download Tool to create recovery media (select products only).....	52
Restoring and recovering your system.....	52
Creating a system restore	53
Restoring and recovery methods	53
Recovering using HP Recovery media	53
Changing the computer boot order	54
Using HP Sure Recover (select products only).....	54
8 Using HP PC Hardware Diagnostics.....	55
Using HP PC Hardware Diagnostics Windows (select products only).....	55
Using an HP PC Hardware Diagnostics Windows hardware failure ID code.....	55
Accessing HP PC Hardware Diagnostics Windows.....	55
Accessing HP PC Hardware Diagnostics Windows from HP Support Assistant.....	55
Accessing HP PC Hardware Diagnostics Windows from the Start menu (select products only).....	56
Downloading HP PC Hardware Diagnostics Windows.....	56
Downloading the latest HP PC Hardware Diagnostics Windows version from HP.....	56
Downloading the HP PC Hardware Diagnostics Windows from the Microsoft Store.....	56
Downloading HP Hardware Diagnostics Windows by product name or number (select products only)	56

Installing HP PC Hardware Diagnostics Windows.....	57
Using HP PC Hardware Diagnostics UEFI	57
Using an HP PC Hardware Diagnostics UEFI hardware failure ID code.....	57
Starting HP PC Hardware Diagnostics UEFI.....	57
Starting HP PC Hardware Diagnostics UEFI through HP Hotkey Support software (select products only).....	58
Downloading HP PC Hardware Diagnostics UEFI to a USB flash drive.....	58
Downloading the latest HP PC Hardware Diagnostics UEFI version.....	59
Downloading HP PC Hardware Diagnostics UEFI by product name or number (select products only)	59
Using Remote HP PC Hardware Diagnostics UEFI settings (select products only).....	59
Downloading Remote HP PC Hardware Diagnostics UEFI.....	59
Downloading the latest Remote HP PC Hardware Diagnostics UEFI version.....	59
Downloading Remote HP PC Hardware Diagnostics UEFI by product name or number.....	59
Customizing Remote HP PC Hardware Diagnostics UEFI settings.....	60
9 Specifications.....	61
Computer specifications.....	61
Display specifications.....	62
Solid-state drive specifications	62
10 Power cord set requirements	64
Requirements for all countries	64
Requirements for specific countries and regions.....	64
11 Recycling.....	67
Index.....	68

1 Product description

This table provides detailed product information.

Table 1-1 Product components and their descriptions

Category	Description
Product Name	HP OmniBook X 14 Inch Laptop AI PC Model numbers: 14-fe0xxx CTO model: 14-fe000
Processors	Qualcomm® Snapdragon processor Qualcomm Snapdragon X Elite X1E78100 (3.4 GHz max frequency, 12 cores, 16 W)
Graphics	Internal graphics Qualcomm Adreno GPU Supports HD decode, DX12
Display	14.0 in (35.6 cm), 2.2 K (2240 × 1400), ultrawide viewing angle (UWVA), BrightView, WLED + low blue light, 100% sRGB, embedded DisplayPort (eDP) 1.4 + panel self refresh (PSR2), low power, 300 nits
Memory	Onboard system memory, not customer accessible or upgradeable 32 GB, LPDDR5X-8448 16 GB, LPDDR5X-8488 Dual channel support
Primary storage	PCIe, NVMe, M.2 2280 solid-state drive (SSD) 2 TB 1 TB 512 GB
Audio and video	Poly Studio Dual speakers Supports HP Audio Boost 2.0 HP 5 MP Camera: indicator 1× infrared (IR) LED, BSI sensor, f2.0, WDR/TNR/HDR, 88° WFOV 5 MP by 30 frames per second (FPS) Supports Windows Hello Dual-array digital microphone with appropriate software: beam forming, echo cancellation, noise suppression
Wireless	Integrated wireless options with dual antennas <ul style="list-style-type: none">Qualcomm FastConnect 6900 Wi-Fi® 6E + Bluetooth® 5.3 Dual Band Simultaneous (DBS)Qualcomm FastConnect 7800 Wi-Fi 7 + Bluetooth 5.4 High Band Simultaneous (HBS) Compatible with Miracast® devices

Table 1-1 Product components and their descriptions (continued)

Category	Description
	Modern Standby (Connected)
	BT audio offload
	Bluetooth LE Audio
	Wi-Fi BIOS SAR
	UNII-4 5 GHz channel
Ports	Audio-out (headphone)/audio-in (microphone) combo jack
	USB 3.2 Gen 2 Type-A (supports HP Sleep & Charge) (right side)
	USB4 Type-C® 40 Gbps (supports data transfer, power delivery 3.0, HP Sleep & Charge, DisplayPort™ 1.4a out up to 2 × 4 K @ 60 Hz [60 Hz] or 1 × 5 K [60 Hz])
	USB 3.2 Type-C 10 Gbps (supports data transfer, power delivery 3.0, HP Sleep & Charge, DisplayPort™ 1.4a out up to 2 × 4 K @ 60 Hz [60 Hz] or 1 × 5 K [60 Hz])
Keyboard	Keyboard
	Full size, backlit, island style, 3-coat paint
	Touchpad requirements
	Clickpad with image sensor
	Multitouch gestures enabled
	Precision touchpad support
	Modern trackpad gestures support
	Taps enabled as default
Power requirements	Battery
	3 cell, 59 Whr
	HP long life
	HP Fast Charge Technology
	Smart AC adapters (65 W, USB Type-C, slim, straight)
	Power cord
	C5, 1 m (3.3 ft), premium
Security	Supports Trusted Platform Module (fTPM) 2.0, firmware based
	Camera privacy cover
	Microphone mute
Operating system	Windows® 11 Pro
	Windows 11 Pro High End
	Windows 11 Pro High End China
	Windows 11 Pro China
	Windows 11 Pro Value
	Windows 11 Pro Value China

Table 1-1 Product components and their descriptions (continued)

Category	Description
	Windows 11 Pro Entry
	Windows 11 Pro Entry China
	Windows 11 Home 64 Desktop AIO Chinese Market CPPP
	Windows 11 Home in S Mode for Developed Markets (ML)
	Windows 11 Home in S Mode for Emerging Markets (EM/SL)
	Windows 11 Home in S Mode for China Market
	Windows 11 Home in S Mode for APAC Markets
	Windows 11 Home in S Mode for Africa Markets
	Windows 11 Home in S Mode for Indonesia Market
	Windows 11 Home in S Mode for India Market
	Windows 11 Home for Developed Market (ML)
	Windows 11 Home for Developed Market (ML)
	Windows 11 Home for Emerging Market (EM/SL)
	Windows 11 Home for China Market
	Windows 11 Home for India Market
	Windows 11 Home for Indonesia Market
	Windows 11 Home for APAC Market
	Windows 11 Home for Africa PPP Market
	FreeDOS 3.0
Serviceability	End user replaceable parts
	AC adapter

2 Getting to know your computer

Your computer features top-rated components. This chapter provides details about your components, where they are located, and how they work.

Right side

Identify the components on the right side of the computer.

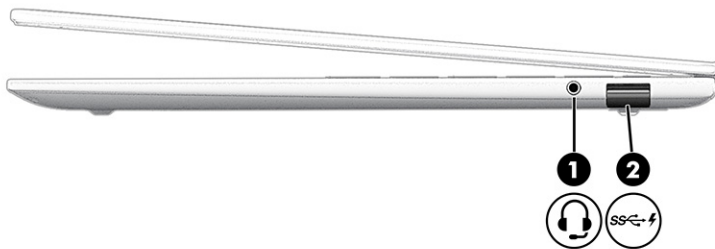



Table 2-1 Right-side components and their descriptions

	Component	Description
(1)	 Audio-out (headphone)/Audio-in (microphone) combo jack	<p>Connects optional powered stereo speakers, headphones, earbuds, a headset, or a television audio cable. Also connects an optional headset microphone. This jack does not support optional standalone microphones.</p> <p>WARNING! To reduce the risk of personal injury, adjust the volume before putting on headphones, earbuds, or a headset. For additional safety information, see the <i>Regulatory, Safety, and Environmental Notices</i>.</p> <p>To access this guide:</p> <ul style="list-style-type: none">■ Select the Search icon in the taskbar, type HP Documentation in the search box, and then select HP Documentation. <p>NOTE: When a device is connected to the jack, the computer speakers are disabled.</p>
(2)	 USB 10 Gbps port with HP Sleep and Charge	<p>Connects a USB device, provides high-speed data transfer, and charges small devices (such as a smartphone), even when the computer is off.</p> <p>NOTE: Use a standard USB Type-A charging cable or cable adapter (purchased separately) when charging a small external device.</p>

Left side

Identify the components on the left side of the computer.

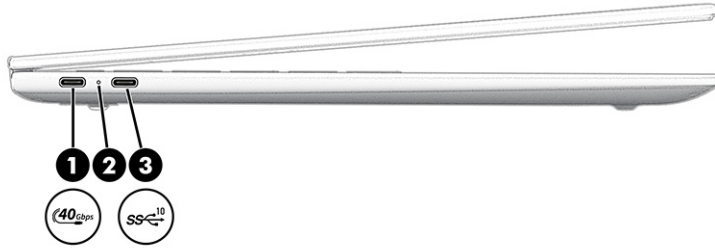



Table 2-2 Left-side components and their descriptions

	Component	Description
(1)	 USB Type-C® power connector and 40 Gbps port with HP Sleep and Charge and DisplayPort™ output	<p>Connects an AC adapter that has a USB Type-C connector, supplying power to the computer and, if needed, charging the computer battery.</p> <p>- and -</p> <p>Connects a USB device, provides high-speed data transfer, and charges small devices (such as a smartphone), even when the computer is off.</p> <p>NOTE: Use a standard USB Type-C charging cable or cable adapter (purchased separately) when charging a small external device.</p> <p>- and -</p> <p>Connects a display device that has a USB Type-C connector, providing DisplayPort output.</p>
(2)	AC adapter and battery light	<ul style="list-style-type: none"> • White: The AC adapter is connected and the battery is fully charged. • Blinking amber: The AC adapter is disconnected and the battery has reached a low battery level. • Amber: The AC adapter is connected and the battery is charging. • Off: The battery is not charging.
(3)	 USB Type-C power connector and 10 Gbps port with HP Sleep and Charge and DisplayPort output	<p>Connects an AC adapter that has a USB Type-C connector, supplying power to the computer and, if needed, charging the computer battery.</p> <p>- and -</p> <p>Connects a USB device, provides high-speed data transfer, and charges small devices (such as a smartphone), even when the computer is off.</p> <p>NOTE: Use a standard USB Type-C charging cable or cable adapter (purchased separately) when charging a small external device.</p> <p>- and -</p> <p>Connects a display device that has a USB Type-C connector, providing DisplayPort output.</p>

Display

The computer display can include essential components such as speakers, antennas, cameras, and microphones.

Low blue light mode (select products only)

Your computer display is shipped from the factory in low blue light mode for improved eye comfort and safety. Also, blue light mode automatically adjusts blue light emissions when you are using the computer at night or for reading.

⚠ WARNING! To reduce the risk of serious injury, read the *Safety & Comfort Guide*. It describes proper workstation setup and proper posture, health, and work habits for computer users. The *Safety & Comfort Guide* also provides important electrical and mechanical safety information. The *Safety & Comfort Guide* is available on the web at <http://www.hp.com/ergo>.

Wake-on-voice (select products only)

Use the wake-on-voice feature to bring the computer out of the Sleep state quickly.

To access the wake-on-voice settings, follow these steps:

1. Select the **Search** icon in the taskbar, type `XiaoWei` in the search box, and then select **XiaoWei**.
2. When the tool opens, scan the QR code with your mobile device, which takes you to the settings page, where you can select your wake-on-voice features.
3. Follow the on-screen instructions.

📝 NOTE: Allow the XiaoWei app to continue running on the computer.

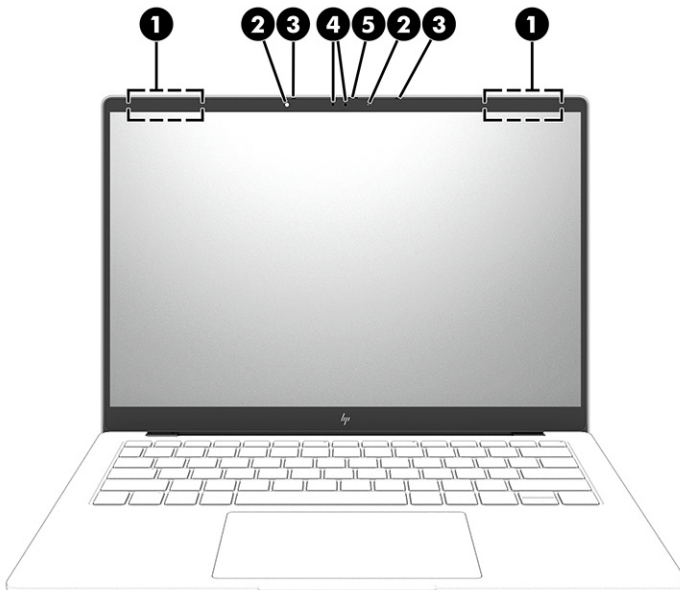

Table 2-3 Display components and their descriptions

Component	Description
(1) WLAN antennas (2)*	Send and receive wireless signals to communicate with wireless local area networks (WLANs).
(2) Camera lights (2)	On: One or more cameras are in use.
(3) Internal microphones (2)	Record sound.
(4) Cameras (2)	Allow you to video chat, record video, and record still images. Some cameras also allow a facial recognition logon to Windows®, instead of a password logon. NOTE: Camera functions vary depending on the camera hardware and software installed on your product.
(5) Camera privacy cover	By default, the camera lens is uncovered, but you can slide the camera privacy cover to block the camera's view. To use the camera, slide the camera privacy cover in the opposite direction to reveal the lens.

*The antennas are not visible from the outside of the computer. For optimal transmission, keep the areas immediately around the antennas free from obstructions.

For wireless regulatory notices, see the section of the *Regulatory, Safety, and Environmental Notices* that applies to your country or region.

To access this guide:

- Select the **Search** icon in the taskbar, type `HP Documentation` in the search box, and then select **HP Documentation**.

Keyboard area

Keyboards can vary by language.

 **NOTE:** The keyboard area, including the function keys and (select products only) power key, is disabled in stand, tent, and tablet modes. To enable the keyboard, including the power key, change to the clamshell mode.

Touchpad settings and components

Learn the touchpad settings and components.

Touchpad settings

Learn how to adjust touchpad settings.

Adjusting touchpad settings

Use these steps to adjust touchpad settings and gestures.

1. Select the **Search** icon in the taskbar, type `touchpad settings` in the search box, and then press `enter`.
2. Choose a setting.

Turning on the touchpad

Follow these steps to turn on the touchpad.

1. Select the **Search** icon in the taskbar, type `touchpad settings` in the search box, and then press `enter`.
2. Using an external mouse, click the **touchpad** button.

If you are not using an external mouse, press the `Tab` key repeatedly until the pointer rests on the **touchpad** button. Then press the `spacebar` to select the button.

Touchpad components

Identify the touchpad components.

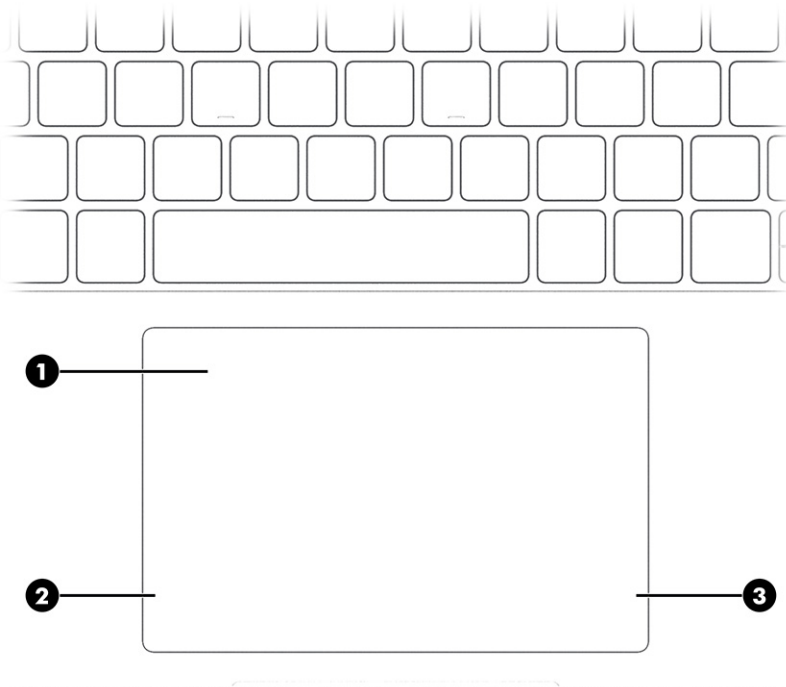

Table 2-4 Touchpad components and their descriptions

	Component	Description
(1)	Touchpad zone	Reads your finger gestures to move the pointer or activate items on the screen.
(2)	Left touchpad button	Functions like the left button on an external mouse.
(3)	Right touchpad button	Functions like the right button on an external mouse.

Lights

Identify the lights on the computer.

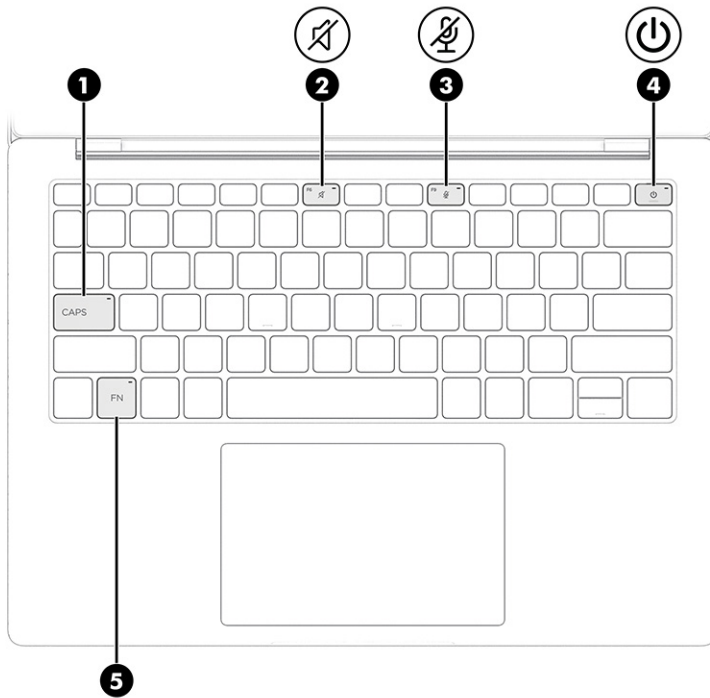





Table 2-5 Lights and their descriptions

	Component	Description
(1)	Caps lock light	On: Caps lock is on, which switches the key input to all capital letters.
(2)	 Mute light	<ul style="list-style-type: none"> On: Computer sound is off. Off: Computer sound is on.
(3)	 Microphone mute light	<ul style="list-style-type: none"> On: Microphone is off. Off: Microphone is on.
(4)	 Power light	<ul style="list-style-type: none"> On: The computer is on. Blinking (select products only): The computer is in the Sleep state, a power-saving state. The computer shuts off power to the display and other unnecessary components. Off: Depending on your computer model, the computer is off, in Hibernation, or in Sleep. Hibernation is the power-saving state that uses the least amount of power.
(5)	Fn lock light	On: The fn key is locked.

Special keys

Identify the special keys.

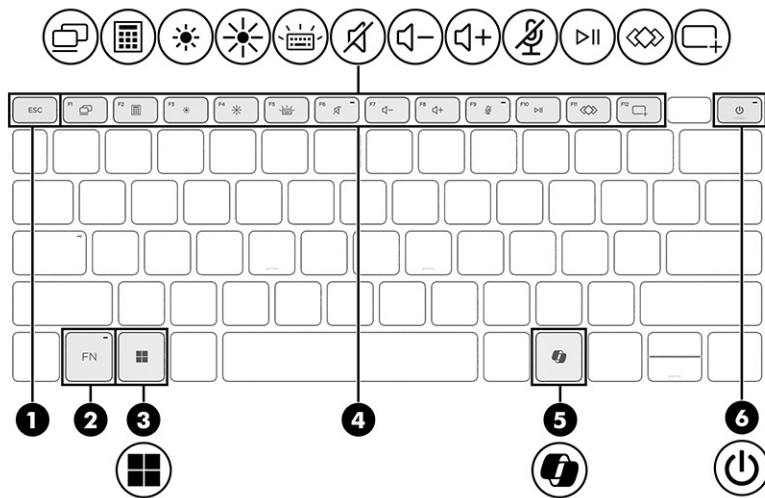

Table 2-6 Special keys and their descriptions





	Component	Description
(1)	esc key	Displays system information when pressed in combination with the fn key.
(2)	fn key	Executes specific functions when pressed in combination with another key.
(3)	 Windows key	Opens the Start menu. NOTE: Pressing the Windows key again will close the Start menu.
(4)	Action keys	Execute frequently used system functions as defined by the icon symbols on f1 through f12 function keys.
(5)	 Windows Copilot key	Opens Windows Copilot in Windows/Bing/Edge and Copilot Key*. Comes with Windows 11 (where available). NOTE: Requires Windows 11. Some features require an NPU. Timing of feature delivery and availability varies by market and device. Requires Microsoft account to log in. Where Copilot is not available, the Copilot key will lead to the Bing search engine. See http://aka.ms/WindowsAIFeatures .

Table 2-6 Special keys and their descriptions (continued)

	Component	Description
(6)	 Power button	<ul style="list-style-type: none"> When the computer is off, press the button briefly to turn on the computer. When the computer is on, press the button briefly to initiate Sleep. When the computer is in the Sleep state, press the button briefly to exit Sleep (select products only). When the computer is in Hibernation, press the button briefly to exit Hibernation. <p>IMPORTANT: Pressing and holding down the power button results in the loss of unsaved information.</p> <p>If the computer has stopped responding and shutdown procedures are ineffective, press and hold the power button down for at least 10 seconds to turn off the computer.</p> <p>To learn more about your power and sleep settings:</p> <ul style="list-style-type: none"> Right-click the Power icon , and then select Power and sleep settings.

Bottom

Identify the bottom components.

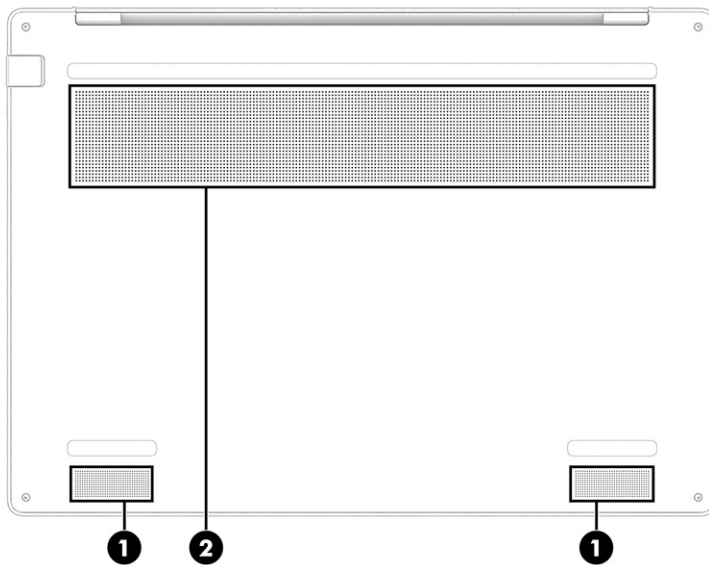

Table 2-7 Bottom components and their descriptions

	Component	Description
(1)	Speakers (2)	Produce sound.

Table 2-7 Bottom components and their descriptions (continued)

	Component	Description
(2)	Vent	Enables airflow to cool internal components. NOTE: The computer fan starts up automatically to cool internal components and prevent overheating. It is normal for the internal fan to cycle on and off during routine operation.

Labels

The labels affixed to the computer provide information that you might need when you troubleshoot system problems or travel internationally with the computer. Labels can be in paper form or imprinted on the product.

 **IMPORTANT:** Check the following locations for the labels described in this section: the bottom of the computer, inside the battery bay, under the service door, on the back of the display, or on the bottom of a tablet kickstand.

- Service label—Provides important information to identify your computer. When contacting support, you might be asked for the serial number, the product number, or the model number. Locate this information before you contact support.

Your service label will resemble the following example.

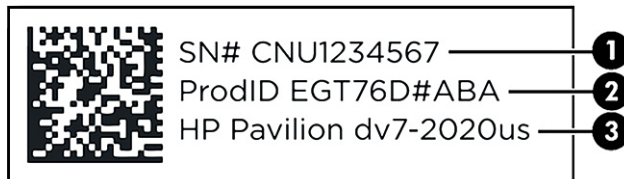

Table 2-8 Service label components

Component
(1) Serial number
(2) Product ID
(3) HP product name and model number

- Regulatory labels—Provide regulatory information about the computer.
- Wireless certification labels—Provide information about optional wireless devices and the approval markings for the countries or regions in which the devices have been approved for use.

3 Illustrated parts catalog

Use this chapter to determine the spare parts that are available for the computer.

Computer major components

To identify the computer major components, use this illustration and table.

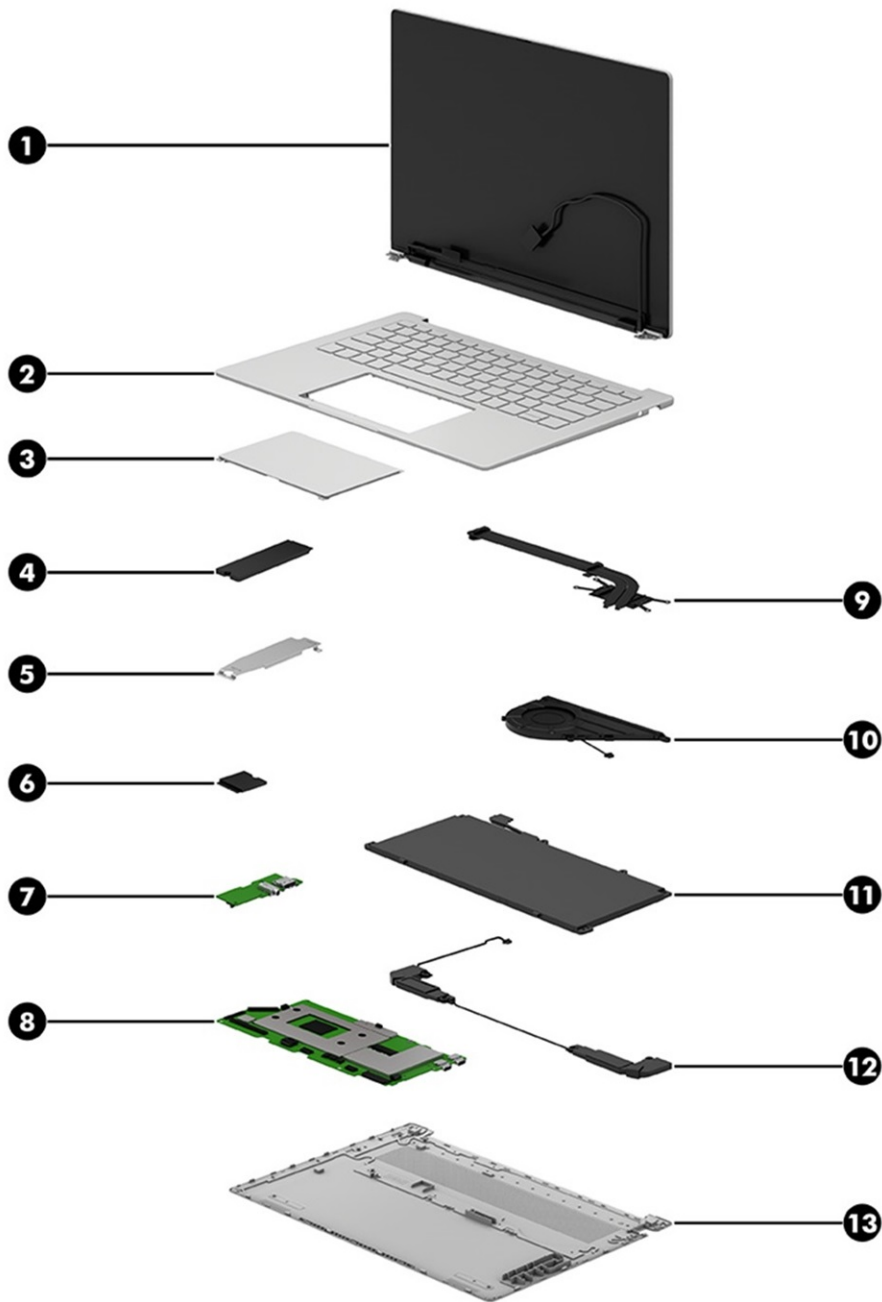

Table 3-1 Computer major component descriptions and part numbers

Item	Component	Spare part number
(1)	Display assembly (includes cable) NOTE: Only the entire display assembly is available as a spare part. Future repair strategy might change to display components available only at the subcomponent level, in which case the entire display assembly would not be available as a spare part. Be sure to check on the display spare part strategy prior to starting the repair process.	
	Meteor silver	P12803-001
	Ceramic white	P12804-001
(2)	Keyboard NOTE: For a list of keyboard country codes, see Top cover with keyboard on page 47 .	
	Meteor silver top cover, soft gray keyboard	N99794-xx1
	Ceramic white top cover, ceramic white keyboard	P02386-xx1
(3)	Touchpad NOTE: The touchpad cable is available as spare part number P05978-001.	
	Meteor silver	N99789-001
	Ceramic white	P02385-001
(4)	Solid-state drive NOTE: The solid-state drive thermal pad is available as spare part number N99800-001.	
	2 TB	P07215-005
	1 TB	N45474-005
	512 GB	N45476-005
(5)	SSD cover	not available as a spare part
(6)	WLAN module	
	Qualcomm FastConnect 6900 Wi-Fi 6E + Bluetooth 5.3 Dual Band Simultaneous (DBS) (includes protective tape)	N99797-001
	Qualcomm FastConnect 7800 Wi-Fi 7 + Bluetooth 5.4 High Band Simultaneous (HBS) (includes thermal pads)	N99798-001
(7)	USB board (includes RJ-45 door) NOTE: The USB board cable is available as spare part number P05977-001. NOTE: The RJ-45 door is available as spare part number N99786-001.	N99787-001
(8)	System board (includes processor and system memory; includes thermal grease)	
	Qualcomm Snapdragon X Elite X1E78100 processor and 32 GB of system memory	P08100-601
	Qualcomm Snapdragon X Elite X1E78100 processor and 16 GB of system memory	N99780-601
(9)	Heat sink	N99793-001
(10)	Fan	N99792-001
(11)	Battery (3 cell, 59 Whr) NOTE: The battery cable is available as spare part number P05980-001.	N66215-005

Table 3-1 Computer major component descriptions and part numbers (continued)

Item	Component	Spare part number
(12)	Speakers (left and right)	N99795-001
(13)	Bottom cover	
	Meteor silver	N99784-001
	Ceramic white	P02384-001

Miscellaneous parts

To identify the miscellaneous parts, use this table.

Table 3-2 Miscellaneous part descriptions and part numbers

Component	Spare part number
AC adapter (65 W, USB Type-C)	M54350-001
Screw Kit	N99796-001
Power cords (C5, premium, 1.0 m [3.3 ft])	
Australia	L22327-001
Denmark	L22322-001
Europe (Austria, Belgium, Finland, France, Germany, the Netherlands, Norway, and Sweden)	L22321-001
India	L22624-001
Japan	L22330-001
North America	L22319-001
South Korea	L22328-001
Switzerland	L22324-001
Thailand	L22326-001
Thailand (bundle)	M85421-001
United Kingdom	L22320-001

4 Removal and replacement procedures preliminary requirements

Use this information to properly prepare to disassemble and reassemble the computer.

Tools required

You need the following tools to complete the removal and replacement procedures:

- Tweezers
- Nonconductive, nonmarking pry tool
- Magnetic Phillips P1 screwdriver

Service considerations

The following sections include some of the considerations that you must keep in mind during disassembly and assembly procedures.

 **NOTE:** As you remove each subassembly from the computer, place the subassembly (and all accompanying screws) away from the work area to prevent damage.

Plastic parts

Using excessive force during disassembly and reassembly can damage plastic parts.

Cables and connectors

Handle cables with extreme care to avoid damage.

 **IMPORTANT:** When servicing the computer, be sure that cables are placed in their proper locations during the reassembly process. Improper cable placement can damage the computer.

Apply only the tension required to unseat or seat the cables during removal and insertion. Handle cables by the connector whenever possible. In all cases, avoid bending, twisting, or tearing cables. Be sure that cables are routed so that they cannot be caught or snagged as you remove or replace parts. Handle flex cables with extreme care; these cables tear easily.

Drive handling

Note the following guidelines when handling drives.

 **IMPORTANT:** Drives are fragile components. Handle them with care. To prevent damage to the computer, damage to a drive, or loss of information, observe these precautions:

- Before removing or inserting a hard drive, shut down the computer. If you are unsure whether the computer is off or in Hibernation, turn the computer on, and then shut it down through the operating system.

- Before handling a drive, be sure that you are discharged of static electricity. While handling a drive, avoid touching the connector.
 - Before removing an optical drive, be sure that a disc is not in the drive, and be sure that the optical drive tray is closed.
 - Handle drives on surfaces covered with at least 2.54 cm (1 inch) of shock-proof foam.
 - Avoid dropping drives from any height onto any surface.
 - After removing a hard drive or an optical drive, place it in a static-proof bag.
 - Avoid exposing an internal hard drive to products that have magnetic fields, such as monitors or speakers.
 - Avoid exposing a drive to temperature extremes or liquids.
 - If a drive must be mailed, place the drive in a bubble pack mailer or other suitable form of protective packaging, and label the package "FRAGILE."
-

Electrostatic discharge information

A sudden discharge of static electricity from your finger or other conductor can destroy static-sensitive devices or microcircuitry. Often the spark is neither felt nor heard, but damage occurs. An electronic device exposed to electrostatic discharge (ESD) might not appear to be affected at all and can work perfectly throughout a normal cycle. The device might function normally for a while, but it has been degraded in the internal layers, reducing its life expectancy.

Networks built into many integrated circuits provide some protection, but in many cases, the discharge contains enough power to alter device parameters or melt silicon junctions.

 **IMPORTANT:** To prevent damage to the device when you remove or install internal components, observe these precautions:

- Keep components in their electrostatic-safe containers until you are ready to install them.
 - Before touching an electronic component, discharge static electricity by using the guidelines described in [Personal grounding methods and equipment on page 18](#).
 - Avoid touching pins, leads, and circuitry. Handle electronic components as little as possible.
 - If you remove a component, place it in an electrostatic-safe container.
-

Generating static electricity

Follow these static electricity guidelines:

- Different activities generate different amounts of static electricity.
- Static electricity increases as humidity decreases.

Table 4-1 Static electricity occurrence based on activity and humidity

Event	Relative humidity		
	55%	40%	10%
Walking across carpet	7,500 V	15,000 V	35,000 V
Walking across vinyl floor	3,000 V	5,000 V	12,000 V
Motions of bench worker	400 V	800 V	6,000 V
Removing dual in-line packages (DIPs) from plastic tube	400 V	700 V	2,000 V
Removing DIPs from vinyl tray	2,000 V	4,000 V	11,500 V
Removing DIPs from polystyrene foam	3,500 V	5,000 V	14,500 V
Removing bubble pack from PCB (printed circuit board)	7,000 V	20,000 V	26,500 V
Packing PCBs in foam-lined box	5,000 V	11,000 V	21,000 V



NOTE: Multiple electric components can be packaged together in plastic tubes, trays, or polystyrene foam.

As little as 700 V of static electricity can degrade a product.

Preventing electrostatic damage to equipment

Many electronic components are sensitive to ESD. Circuitry design and structure determine the degree of sensitivity.

The following packaging and grounding precautions are necessary to prevent static electricity damage to electronic components:

- To avoid hand contact, transport products in static-safe containers such as tubes, bags, or boxes.
- Protect all electrostatic parts and assemblies with conductive or approved containers or packaging.
- Keep electrostatic-sensitive parts in their containers until they arrive at static-free stations.
- Place items on a grounded surface before removing them from their container.
- Always be properly grounded when touching a sensitive component or assembly.
- Avoid contact with pins, leads, or circuitry.
- Place reusable electrostatic-sensitive parts from assemblies in protective packaging or conductive foam.

Personal grounding methods and equipment

Using certain equipment can prevent static electricity damage to electronic components.

- **Wrist straps** are flexible straps with a maximum of $1\text{ M}\Omega \pm 10\%$ resistance in the ground cords. To provide proper ground, a strap must be worn snug against bare skin. The ground cord must be connected and fit snugly into the banana plug connector on the grounding mat or workstation.

- You can use **heel straps, toe straps, and boot straps** at standing workstations. These straps are compatible with most types of shoes or boots. On conductive floors or dissipative floor mats, use them on both feet with a maximum of $1\text{ M}\Omega \pm 10\%$ resistance between the operator and ground.

Table 4-2 Static shielding protection levels

Static shielding protection levels	
Method	Voltage
Antistatic plastic	1,500
Carbon-loaded plastic	7,500
Metallized laminate	15,000

Grounding the work area

To prevent static damage at the work area, follow these precautions:

- Cover the work surface with approved static-dissipative material.
- Use a wrist strap connected to a properly grounded work surface and use properly grounded tools and equipment.
- Use static-dissipative mats, foot straps, or air ionizers to give added protection.
- Handle electrostatic sensitive components, parts, and assemblies by the case or PCB laminate. Handle them only at static-free work areas.
- Turn off power and input signals before inserting and removing connectors or test equipment.
- Use fixtures made of static-safe materials when fixtures must directly contact dissipative surfaces.
- Keep the work area free of nonconductive materials, such as ordinary plastic assembly aids and polystyrene foam.
- Use conductive field service tools, such as cutters, screwdrivers, and vacuums.
- Avoid contact with pins, leads, or circuitry.

Recommended materials and equipment

HP recommends certain materials and equipment to prevent static electricity:

- Antistatic tape
- Antistatic smocks, aprons, or sleeve protectors
- Conductive bins and other assembly or soldering aids
- Conductive foam
- Conductive tabletop workstations with ground cord of $1\text{ M}\Omega \pm 10\%$ resistance
- Static-dissipative table or floor mats with hard tie to ground
- Field service kits
- Static awareness labels

- Wrist straps and footwear straps providing 1 MΩ ±10% resistance
- Material handling packages
- Conductive plastic bags
- Conductive plastic tubes
- Conductive tote boxes
- Opaque shielding bags
- Transparent metallized shielding bags
- Transparent shielding tubes

Cleaning your computer

Cleaning your computer regularly removes dirt and debris so that your device continues to operate at its best. Use the following information to safely clean the external surfaces of your computer.

Enabling HP Easy Clean (select products only)

HP Easy Clean helps you to avoid accidental input while you clean the computer surfaces. This software disables devices such as the keyboard, touch screen, and touchpad for a preset amount of time so that you can clean all computer surfaces.

1. Start HP Easy Clean in one of the following ways:
 - Select the **Start** menu, and then select **HP Easy Clean**.
 - Select the **HP Easy Clean** icon in the taskbar.
 - Select **Start**, and then select the **HP Easy Clean** tile.
2. Now that your device is disabled for a short period, see [Removing dirt and debris from your computer on page 20](#) for the recommended steps to clean the high-touch, external surfaces on your computer. After you remove the dirt and debris, you can also clean the surfaces with a disinfectant. See [Cleaning your computer with a disinfectant on page 21](#) for guidelines to help prevent the spread of harmful bacteria and viruses.

Removing dirt and debris from your computer

Here are the recommended steps to clean dirt and debris from your computer.

For computers with wood veneer, see [Caring for wood veneer \(select products only\) on page 22](#).

1. Wear disposable gloves made of latex (or nitrile gloves, if you are latex-sensitive) when cleaning the surfaces.
2. Turn off your device and unplug the power cord and other connected external devices. Remove any installed batteries from items such as wireless keyboards.

⚠ CAUTION: To prevent electric shock or damage to components, never clean a product while it is turned on or plugged in.

3. Moisten a microfiber cloth with water. The cloth should be moist, but not dripping wet.

 **IMPORTANT:** To avoid damaging the surface, avoid abrasive cloths, towels, and paper towels.

4. Wipe the exterior of the product gently with the moistened cloth.

 **IMPORTANT:** Keep liquids away from the product. Avoid getting moisture in any openings. If liquid makes its way inside your HP product, it can cause damage to the product. Do not spray liquids directly on the product. Do not use aerosol sprays, solvents, abrasives, or cleaners containing hydrogen peroxide or bleach that might damage the finish.

5. Start with the display (if applicable). Wipe carefully in one direction, and move from the top of the display to the bottom. Finish with any flexible cables, like power cord, keyboard cable, and USB cables.
6. Be sure that surfaces have completely air-dried before turning the device on after cleaning.
7. Discard the gloves after each cleaning. Clean your hands immediately after you remove the gloves.

See [Cleaning your computer with a disinfectant on page 21](#) for recommended steps to clean the high-touch, external surfaces on your computer to help prevent the spread of harmful bacteria and viruses.

Cleaning your computer with a disinfectant

The World Health Organization (WHO) recommends cleaning surfaces, followed by disinfection, as a best practice for preventing the spread of viral respiratory illnesses and harmful bacteria.

After cleaning the external surfaces of your computer using the steps in [Removing dirt and debris from your computer on page 20](#), [Caring for wood veneer \(select products only\) on page 22](#), or both, you might also choose to clean the surfaces with a disinfectant. A disinfectant that is within HP's cleaning guidelines is an alcohol solution consisting of 70% isopropyl alcohol and 30% water. This solution is also known as rubbing alcohol and is sold in most stores.

Follow these steps when disinfecting high-touch, external surfaces on your computer:

1. Wear disposable gloves made of latex (or nitrile gloves, if you are latex-sensitive) when cleaning the surfaces.
2. Turn off your device and unplug the power cord and other connected external devices. Remove any installed batteries from items such as wireless keyboards.

 **CAUTION:** To prevent electric shock or damage to components, never clean a product while it is turned on or plugged in.

3. Moisten a microfiber cloth with a mixture of 70% isopropyl alcohol and 30% water. The cloth should be moist, but not dripping wet.

 **CAUTION:** Do not use any of the following chemicals or any solutions that contain them, including spray-based surface cleaners: bleach, peroxides (including hydrogen peroxide), acetone, ammonia, ethyl alcohol, methylene chloride, or any petroleum-based materials, such as gasoline, paint thinner, benzene, or toluene.

 **IMPORTANT:** To avoid damaging the surface, avoid abrasive cloths, towels, and paper towels.

4. Wipe the exterior of the product gently with the moistened cloth.

 **IMPORTANT:** Keep liquids away from the product. Avoid getting moisture in any openings. If liquid makes its way inside your HP product, it can cause damage to the product. Do not spray liquids directly on the product. Do not use aerosol sprays, solvents, abrasives, or cleaners containing hydrogen peroxide or bleach that might damage the finish.

5. Start with the display (if applicable). Wipe carefully in one direction, and move from the top of the display to the bottom. Finish with any flexible cables, like power cord, keyboard cable, and USB cables.
6. Be sure that surfaces have completely air-dried before turning the device on after cleaning.
7. Discard the gloves after each cleaning. Clean your hands immediately after you remove the gloves.

Caring for wood veneer (select products only)

Your product might feature high-quality wood veneer. As with all natural wood products, proper care is important for best results over the life of the product. Because of the nature of natural wood, you might see unique variations in the grain pattern or subtle variations in color, which are normal.

- Clean the wood with a dry, static-free microfiber cloth or chamois.
- Avoid cleaning products containing substances such as ammonia, methylene chloride, acetone, turpentine, or other petroleum-based solvents.
- Do not expose the wood to sun or moisture for long periods of time.
- If the wood becomes wet, dry it by dabbing with an absorbent, lint-free cloth.
- Avoid contact with any substance that might dye or discolor the wood.
- Avoid contact with sharp objects or rough surfaces that might scratch the wood.

See [Removing dirt and debris from your computer on page 20](#) for the recommended steps to clean the high-touch, external surfaces on your computer. After you remove the dirt and debris, you can also clean the surfaces with a disinfectant. See [Cleaning your computer with a disinfectant on page 21](#) for sanitizing guidelines to help prevent the spread of harmful bacteria and viruses.

Packaging and transporting guidelines

Follow these grounding guidelines when packaging and transporting equipment:

- To avoid hand contact, transport products in static-safe tubes, bags, or boxes.
- Protect ESD-sensitive parts and assemblies with conductive or approved containers or packaging.
- Keep ESD-sensitive parts in their containers until the parts arrive at static-free workstations.
- Place items on a grounded surface before removing items from their containers.
- Always be properly grounded when touching a component or assembly.
- Store reusable ESD-sensitive parts from assemblies in protective packaging or nonconductive foam.

- Use transporters and conveyors made of antistatic belts and roller bushings. Be sure that mechanized equipment used for moving materials is wired to ground and that proper materials are selected to avoid static charging. When grounding is not possible, use an ionizer to dissipate electric charges.

Accessing support information

To find the HP support that you need, use this information.

Table 4-3 Support information locations



Service consideration	Path to access information
Records of reported failure incidents stored on the computer	<p>Windows®:</p> <p>Preoperating system failures are logged in the BIOS Event Log. To view the BIOS Event Log:</p> <ol style="list-style-type: none"> 1. Press the power button. 2. Immediately and repeatedly press esc when the power button light turns white. <p>NOTE: If you do not press esc at the appropriate time, you must restart the computer and again repeatedly press esc when the power button light turns white to access the utility.</p> <ol style="list-style-type: none"> 3. Press f10 to enter the BIOS setup. 4. (On commercial products) Under the Main tab, select BIOS event log, and then select View BIOS Event Log. <p>- or -</p> <p>(On consumer products) Under the Main tab, select System Log.</p> <p>Post-operating system failures are logged in the Event Viewer.</p> <ol style="list-style-type: none"> 1. Turn on the computer and allow the operating system to open. 2. Select the search icon  in the taskbar. 3. Type <code>Event Viewer</code>, and then press enter. 4. Select the log from the left panel. Details display in the right panel. <p>Chrome™:</p> <ol style="list-style-type: none"> 1. Go to support.google.com/chrome. 2. Search <code>collect Chrome device logs</code>.
Technical bulletins	<p>To locate technical bulletins:</p> <ol style="list-style-type: none"> 1. Go to www.hp.com. 2. Place the cursor over Problem solving to display more options. 3. Select Support & Troubleshooting. 4. Type the serial number, product number, or product name to go to the product support page. 5. Select Advisories to view technical bulletins.

Table 4-3 Support information locations (continued)

Service consideration	Path to access information
Repair professionals	To locate repair professionals: <ol style="list-style-type: none"><li data-bbox="676 310 1437 338">1. Go to www.hp.com.<li data-bbox="676 359 1437 386">2. Place the cursor over Support resources to display more options.<li data-bbox="676 407 1437 434">3. Select Authorized service providers.
Component and diagnosis information, failure detection, and required action	To locate diagnosis information and actions: <ol style="list-style-type: none"><li data-bbox="676 506 1437 533">1. Go to http://www.hp.com/go/techcenter/pcdiags.<li data-bbox="676 554 1437 581">2. Select Get Support.<li data-bbox="676 602 1437 653">3. Near the bottom of the window, select Notebook PCs, and then select your location.

5 Removal and replacement procedures for authorized service provider parts

This chapter provides removal and replacement procedures for authorized service provider parts.

 **IMPORTANT:** Only an authorized service provider should access the components described in this chapter. Accessing these parts can damage the computer or void the warranty.

 **NOTE:** Details about your computer, including model, serial number, product key, and length of warranty, are on the service tag at the bottom of your computer.

 **NOTE:** The [HP Support YouTube Channel](#) (in English) has videos that provide step-by-step removal and replacement instructions for many common parts and models.

Component replacement procedures

To remove and replace computer components, use the procedures described in this section.

 **NOTE:** HP continually improves and changes product parts. For complete and current information about supported parts for your computer, go to <https://partsurfer.hp.com/partsurfer/>, select your country or region, and then follow the on-screen instructions.

Make special note of each screw size and location during removal and replacement.

Preparation for disassembly

To remove and replace computer components, use these procedures:

For initial safety procedures, see [Removal and replacement procedures preliminary requirements on page 16](#).

1. Turn off the computer. If you are unsure whether the computer is off or in Hibernation, turn the computer on, and then shut it down through the operating system.
2. Disconnect the power from the computer by unplugging the power cord from the computer.
3. Disconnect all external devices from the computer.

Bottom cover

To remove the bottom cover, use this procedure and illustration.

Table 5-1 Bottom cover descriptions and part numbers

Description	Spare part number
Meteor silver	N99784-001
Ceramic white	P02384-001

Before removing the bottom cover, prepare the computer for disassembly (see [Preparation for disassembly on page 25](#)).

Remove the bottom cover:

1. Remove the two Phillips M2.0 × 7.0 screws **(1)** and the two Phillips M2.0 × 3.5 screws **(2)** from the bottom cover.

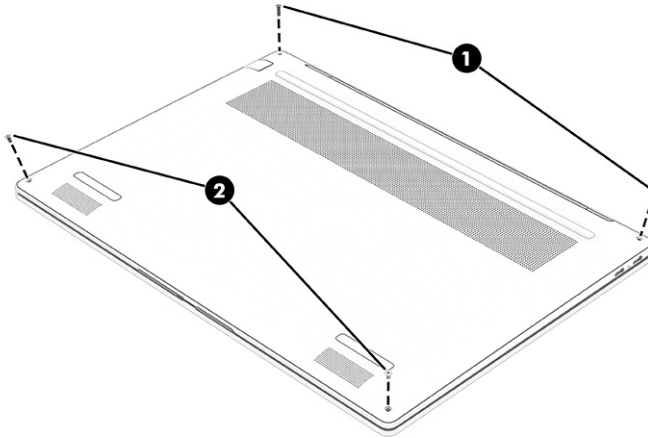

2. Insert a plastic tool **(1)** into the seam between the hinges to release the bottom cover from the computer.
3. Remove the bottom cover **(2)**.

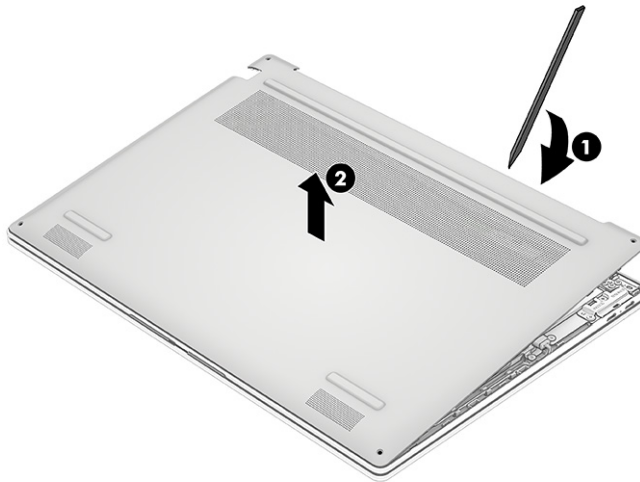

To replace the bottom cover, reverse the removal procedures.

Battery

To remove the battery, use this procedure and illustration.

Table 5-2 Battery descriptions and part numbers

Descriptions	Spare part numbers
3 cell, 59 Whr, Li-ion battery	N66215-005
Battery cable	P05980-001

 **WARNING!** To avoid personal injury and damage to the product:

- Do *not* puncture, twist, or crack the battery.
- Do *not* cause an external puncture or rupture to the battery. They can cause a short inside the battery, which can result in battery thermal runaway.
- Do *not* handle or touch the battery enclosure with sharp objects such as tweezers or pliers, which might puncture the battery.
- Do *not* compress or squeeze the battery case with tools or heavy objects stacked on top of the case. These actions can apply undue force on the battery.
- Do *not* touch the connectors with any metallic surface or object, such as metal tools, screws, or coins, which can cause shorting across the connectors.

Before removing the battery, follow these steps:

1. Prepare the computer for disassembly (see [Preparation for disassembly on page 25](#)).
2. Remove the bottom cover (see [Bottom cover on page 25](#)).

 **WARNING!** To reduce potential safety issues, use only the user-replaceable battery provided with the computer, a replacement battery provided by HP, or a compatible battery purchased from HP.

 **IMPORTANT:** Removing a battery that is the sole power source for the computer can cause loss of information. To prevent loss of information, save your work or shut down the computer through Windows before you remove the battery.

Remove the battery:

 **NOTE:** When replacing the battery or reconnecting the battery cable, be sure to completely reassemble the computer and plug in the AC adapter before turning the computer on.

1. Disconnect the battery cable **(1)** from the system board.
2. Remove the six Phillips M2.0 × 3.0 screws **(2)** that secure the battery to the computer.

- Remove the battery (3) from the computer.

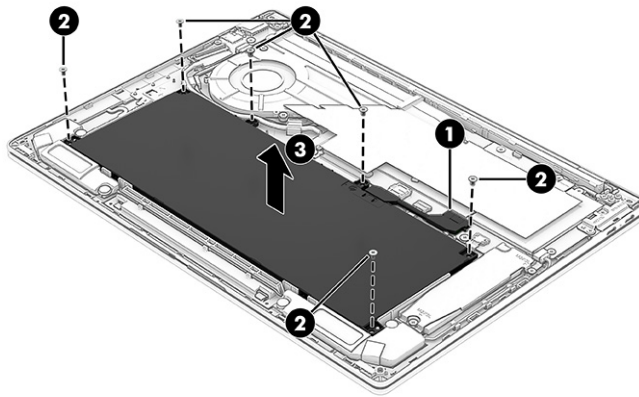

- The battery comes with a removable cable. You do not have to remove the battery to replace the cable. To remove the battery cable, disconnect the cable from the system board (1) and the battery (2), and then remove the cable (3).

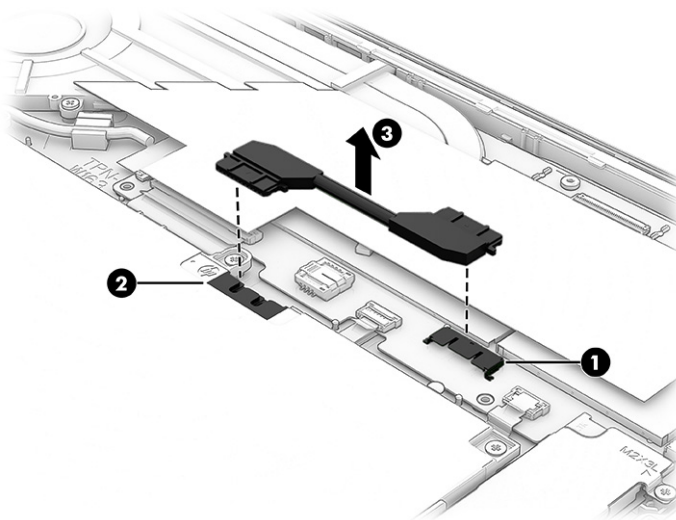

To install the battery, reverse the removal procedures.

Solid-state drive

To remove an SSD, use this procedure and illustration.

Table 5-3 Solid-state drive descriptions and part numbers

Description	Spare part number
2 TB	P07215-005
1 TB	N45474-005
512 GB	N45476-005
SSD thermal pad	N99800-001

Before removing the SSD, follow these steps:

1. Prepare the computer for disassembly (see [Preparation for disassembly on page 25](#)).
2. Remove the bottom cover (see [Bottom cover on page 25](#)).
3. Disconnect the battery cable from the system board (see [Battery on page 26](#)).

Remove the SSD:

1. Remove the two Phillips M2.0 × 3.0 screws (1) that secure the drive cover, and then pull the cover (2) off the drive.
2. Pull the drive (3) out of the socket.

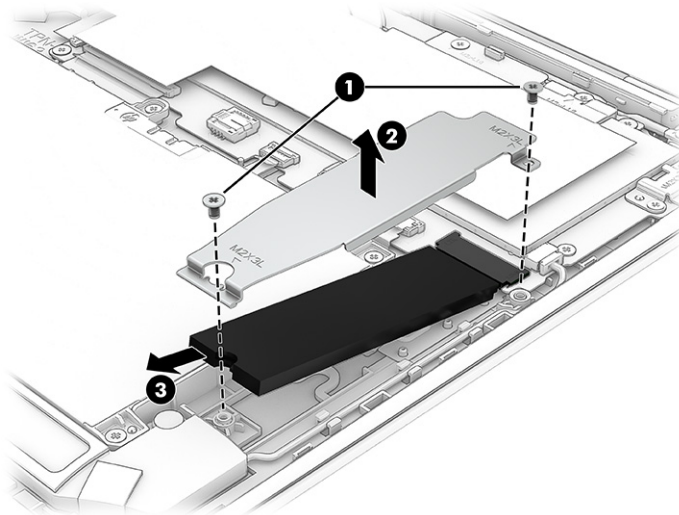

3. When installing an SSD, be sure to install a thermal pad on the bottom of the cover.

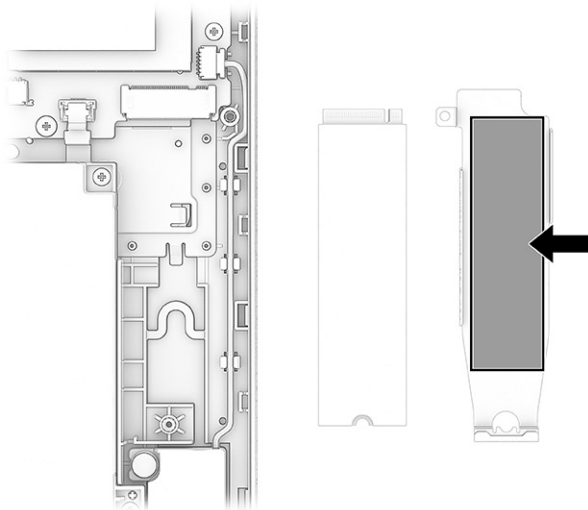

To install an SSD, reverse the removal procedures.

 **NOTE:** SSDs are designed with a notch to prevent incorrect insertion.

Speakers

To remove the speakers, use this procedure and illustration.

Table 5-4 Speaker description and part number

Description	Spare part number
Speaker Kit	N99795-001

Before removing the speakers, follow these steps:

1. Prepare the computer for disassembly (see [Preparation for disassembly on page 25](#)).
2. Remove the bottom cover (see [Bottom cover on page 25](#)).
3. Disconnect the battery cable from the system board (see [Battery on page 26](#)).

Remove the speakers:

1. Disconnect the speaker cable (1) from the system board.
2. Remove the cable from the clips (2) in the computer.
3. Remove the four Phillips M2.0 × 2.0 screws (3) from the battery.
4. Remove the speakers (4) from the computer.
5. Remove the cable from the clips (5) below the battery.



NOTE: When removing the speakers, make note of the location of the rubber isolators (6) in the screw holes. The absence of or damage to these isolators can result in degraded speaker performance.

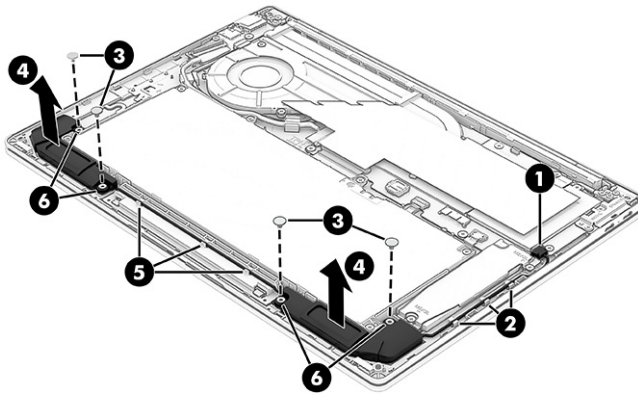

To install the speakers, reverse this procedure.

RJ-45/audio board

To remove the RJ-45/audio board, use this procedure and illustration.

Table 5-5 RJ-45/audio board descriptions and part numbers

Descriptions	Spare part numbers
RJ-45/audio board	N99787-001
RJ-45/audio board cable	P05977-001
RJ-45 door	N99786-001

Before removing the RJ-45/audio board, follow these steps:

1. Prepare the computer for disassembly (see [Preparation for disassembly on page 25](#)).
2. Remove the bottom cover (see [Bottom cover on page 25](#)).
3. Disconnect the battery cable from the system board (see [Battery on page 26](#)).

Remove the RJ-45/audio board:

1. Disconnect the cable from the ZIF connector **(1)** on the board.
2. Remove the three Phillips M2.0 × 1.8 screws **(2)** that secure the board to the computer.
3. Remove the board **(3)** from the computer.

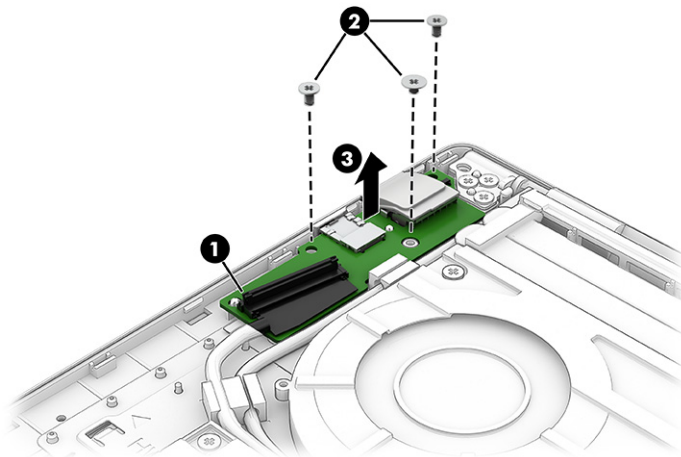

4. To remove the door from the RJ-45/audio board, lift the front of the RJ-45 door to remove it from the RJ-45/audio board.

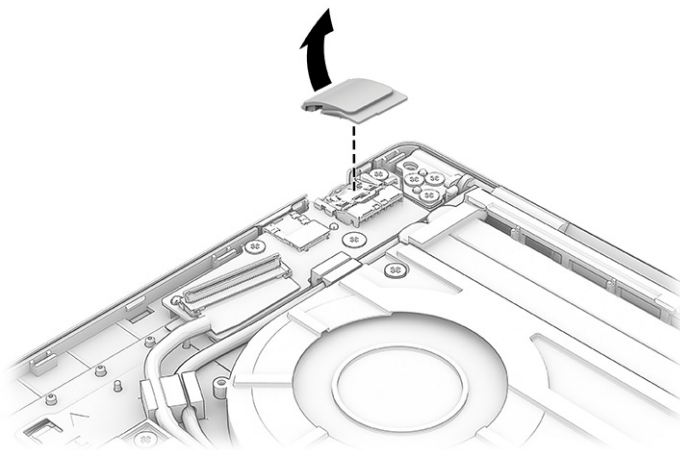

5. To install the door onto the RJ-45/audio board, place the back of the door (1) onto the board, and then press the front of the door (2) down into place

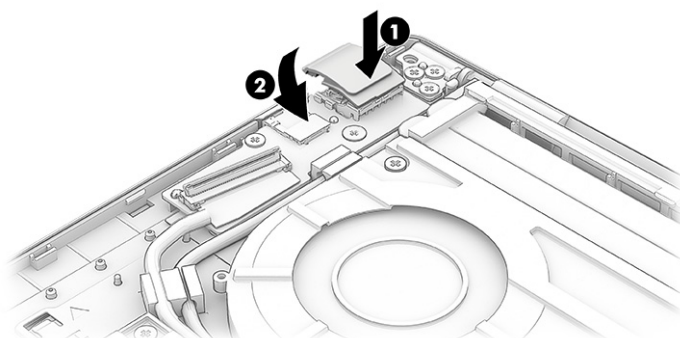

To install the RJ-45/audio board, reverse this procedure.

Touchpad

To remove the touchpad, use this procedure and illustration.

Table 5-6 Touchpad descriptions and part numbers

Description	Spare part number
Touchpad, meteor silver	N99789-001
Touchpad, ceramic white	P02385-001
Touchpad cable	P05978-001

Before removing the touchpad, follow these steps:

1. Prepare the computer for disassembly (see [Preparation for disassembly on page 25](#)).
2. Remove the bottom cover (see [Bottom cover on page 25](#)).

3. Remove the battery (see [Battery on page 26](#)).

Remove the touchpad:

1. Remove the protective tape (1) that covers the screws from the top of the touchpad.
2. Disconnect the touchpad cable from the ZIF connector (2) on the touchpad.
3. Remove the four Phillips M2.0 × 2.0 screws (3) that secure the touchpad to the computer.
4. Lift the top of the touchpad (4) up, and then pull the touchpad (5) into the computer to remove it.

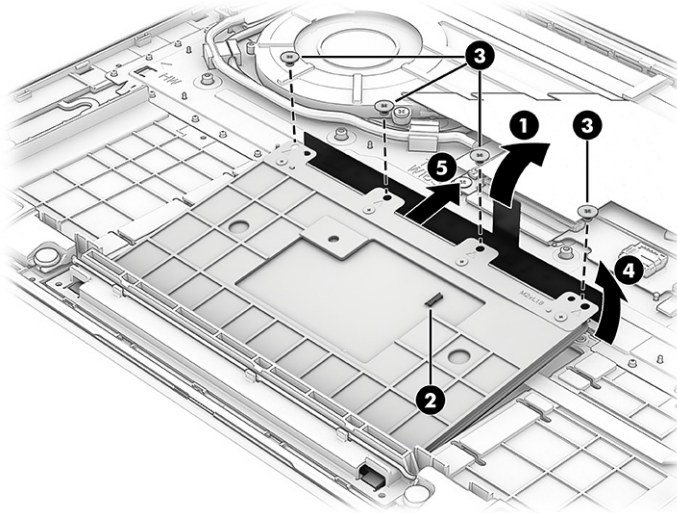

To install the touchpad, reverse this procedure.

System board protective cover

To remove the system board protective cover, use this procedure and illustration.

Table 5-7 System board protective cover description and part number

Description	Spare part number
System board protective cover	P06683-888

Before removing the system board protective cover, follow these steps:

1. Prepare the computer for disassembly (see [Preparation for disassembly on page 25](#)).
2. Remove the bottom cover (see [Bottom cover on page 25](#)).

Remove the system board protective cover:

- Peel the protective cover off the system board.

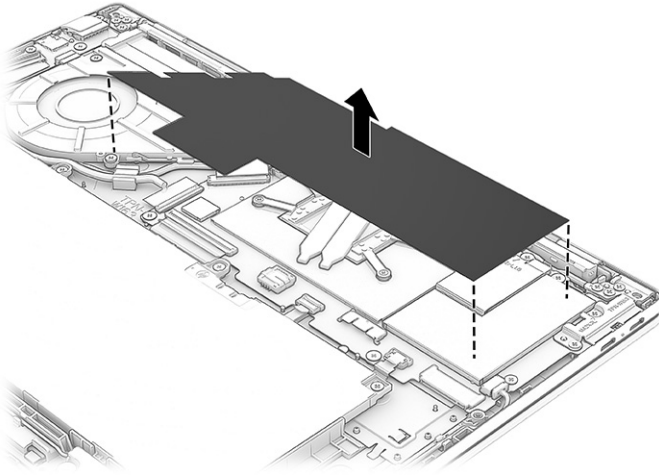

To install the system board protective cover, reverse this procedure.

Fan

To remove the fan, use this procedure and illustration.

Table 5-8 Fan description and part number

Description	Spare part number
Fan	N99792-001

Before removing the fan, follow these steps:

1. Prepare the computer for disassembly (see [Preparation for disassembly on page 25](#)).
2. Remove the bottom cover (see [Bottom cover on page 25](#)).
3. Disconnect the battery cable from the system board (see [Battery on page 26](#)).
4. Remove the protective cover from the system board (see [System board protective cover on page 33](#)).

Remove the fan:

1. Remove the three Phillips M2.0 × 4.0 screws **(1)** that secure the fan to the computer.
2. Disconnect the fan cable from the system board connector **(2)**.
3. Remove the fan **(3)** from the computer.

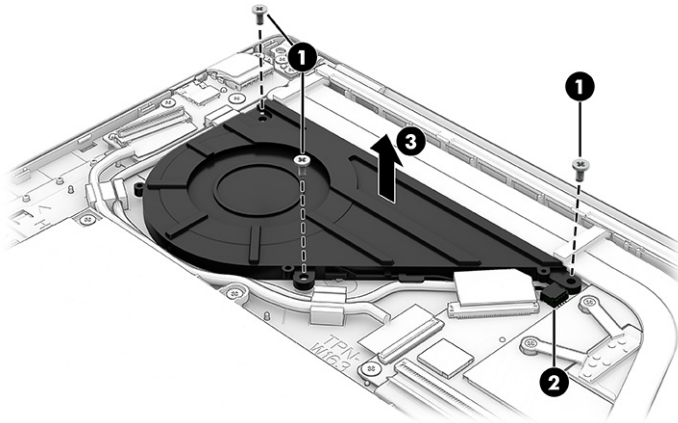

To install the fan, reverse this procedure.

WLAN module

To remove the WLAN module, use this procedure and illustration.

Table 5-9 WLAN module descriptions and part numbers

Description	Spare part number
Qualcomm FastConnect 6900 Wi-Fi 6E + Bluetooth 5.3 Dual Band Simultaneous (DBS)	N99797-001
Qualcomm FastConnect 7800 Wi-Fi 7 + Bluetooth 5.4 High Band Simultaneous (HBS)	N99798-001

IMPORTANT: To prevent an unresponsive system, replace the wireless module only with a wireless module authorized for use in the computer by the governmental agency that regulates wireless devices in your country or region. If you replace the module and then receive a warning message, remove the module to restore device functionality, and then contact technical support.

Before removing the WLAN module, follow these steps:

1. Prepare the computer for disassembly (see [Preparation for disassembly on page 25](#)).
2. Remove the bottom cover (see [Bottom cover on page 25](#)).
3. Disconnect the battery cable from the system board (see [Battery on page 26](#)).
4. Remove the protective cover from the system board (see [System board protective cover on page 33](#)).

Remove the WLAN module from Wi-Fi 6E models:

1. Remove the tape **(1)** that covers the antenna connectors.
2. Carefully disconnect the antenna cables **(2)** from the module.
3. Remove the Phillips M2.0 x 3.0 screw **(3)** from the module.

4. Pull the module **(4)** out of the socket.

 **NOTE:** Models have either one or two WLAN antennas. On models with two antennas, the #1 white WLAN antenna cable connects to the WLAN module #1 Main terminal. The #2 black WLAN antenna cable connects to the WLAN module #1 Aux terminal.

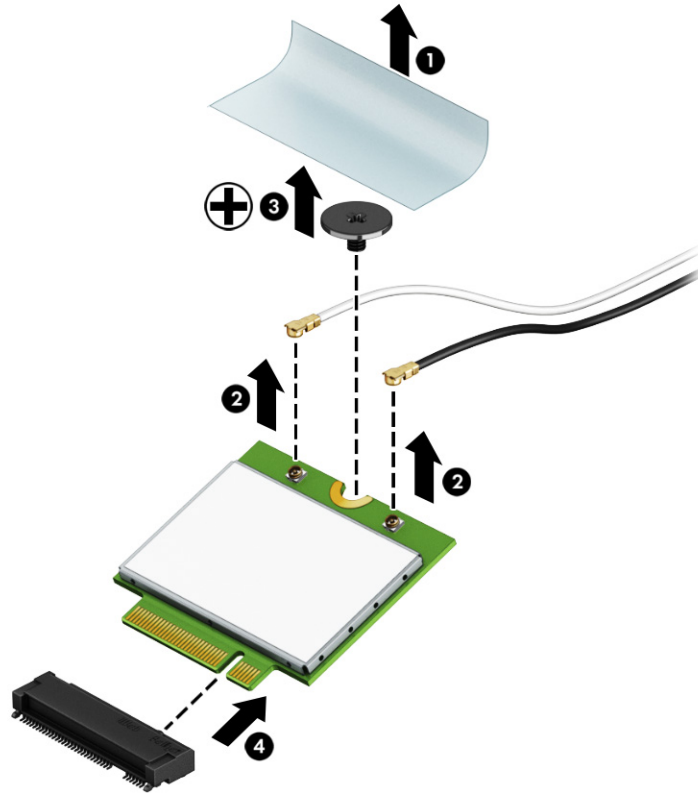

Remove the WLAN module from Wi-Fi 7 models:

1. Remove the Phillips M2.0 × 3.0 screw **(1)**, and then remove the bracket **(2)** that covers the module.
2. Carefully disconnect the antenna cables **(3)** from the module.
3. Pull the module **(4)** out of the socket.

 **NOTE:** Models have either one or two WLAN antennas. On models with two antennas, the #1 white WLAN antenna cable connects to the WLAN module #1 Main terminal. The #2 black WLAN antenna cable connects to the WLAN module #1 Aux terminal.

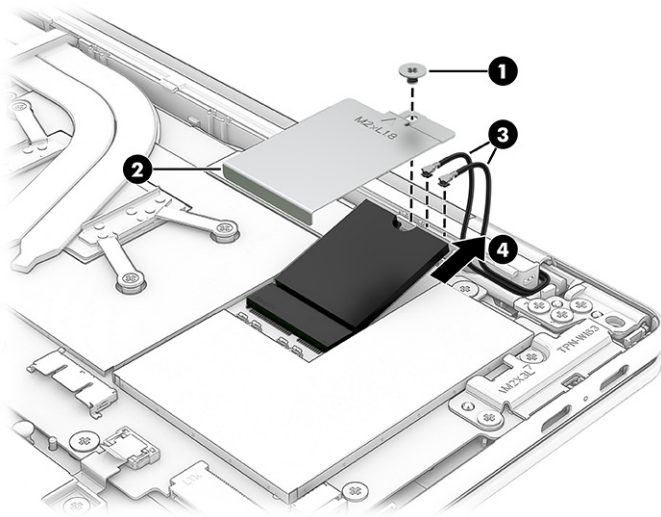

4. When installing a WLAN module, be sure to install a thermal pad on the system board and under the WLAN module bracket.

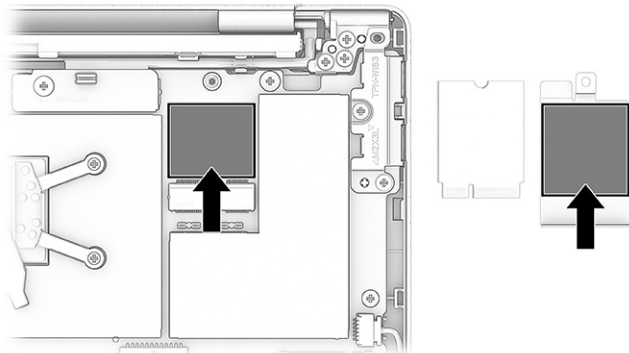

5. If the WLAN antenna is not connected to the terminal on the WLAN module, you must install a protective sleeve on the antenna connector, as shown in the following illustration.

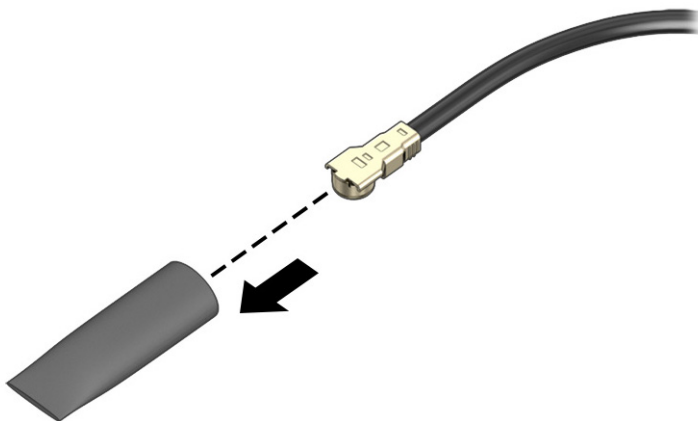

To install the WLAN module, reverse this procedure.

Heat sink

To remove the heat sink, use this procedure and illustration.

Table 5-10 Heat sink description and part number

Description	Spare part number
Heat sink	N99793-001

Before removing the heat sink, follow these steps:

1. Prepare the computer for disassembly (see [Preparation for disassembly on page 25](#)).
2. Remove the bottom cover (see [Bottom cover on page 25](#)).
3. Disconnect the battery cable from the system board (see [Battery on page 26](#)).



NOTE: You do not have to remove the heat sink to remove the system board.

Remove the heat sink:

1. In the order indicated on the heat sink, remove the four Phillips M2.0 × 3.0 screws **(1)** from the heat sink.
2. Remove the heat sink **(2)** from the computer.

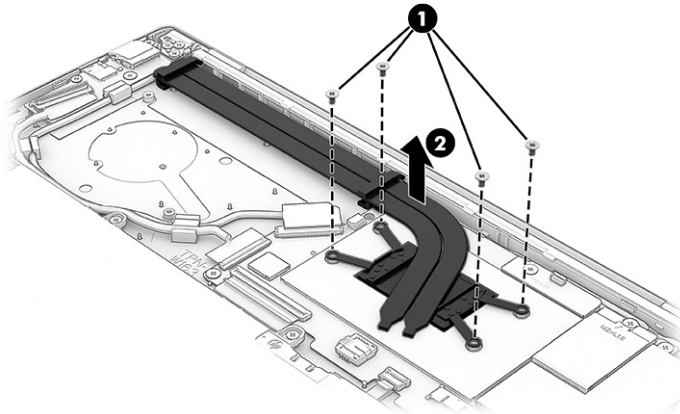

3. Install thermal material onto the bottom of the heat sink each time you remove it.

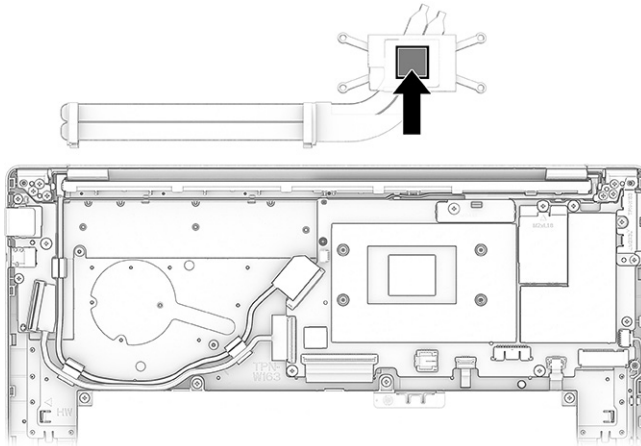

To install the heat sink, reverse this procedure.

System board

To remove the system board, use these procedures and illustrations.

Table 5-11 System board descriptions and part numbers

Description	Spare part number
Qualcomm Snapdragon X Elite X1E78100 processor and 32 GB of system memory	P08100-601
Qualcomm Snapdragon X Elite X1E78100 processor and 16 GB of system memory	N99780-601

Before removing the system board, follow these steps:

1. Prepare the computer for disassembly (see [Preparation for disassembly on page 25](#)).
2. Remove the bottom cover (see [Bottom cover on page 25](#)).
3. Remove the battery (see [Battery on page 26](#)).
4. Remove the WLAN module (see [WLAN module on page 35](#)).
5. Remove the protective cover from the system board (see [System board protective cover on page 33](#)).

 **NOTE:** You do not have to remove the heat sink to remove the system board.

When you replace the system board, be sure to remove the following components (as applicable) from the defective system board and install them on the replacement system board:

- Solid-state drive (see [Solid-state drive on page 28](#)).
- Heat sink (see [Heat sink on page 38](#)).

Remove the system board:

1. Disconnect the following cables from the system board:

- Camera cable shield screw (1)
- Camera cable shield (2)
- Camera cable (ZIF) (3)
- Speaker cable (4)
- Touchpad cable (ZIF) (5)
- Keyboard backlight cable (ZIF) (6)
- Keyboard cable (ZIF) (7)
- RJ-45/audio board cable (ZIF) (8)
- Display cable (9)

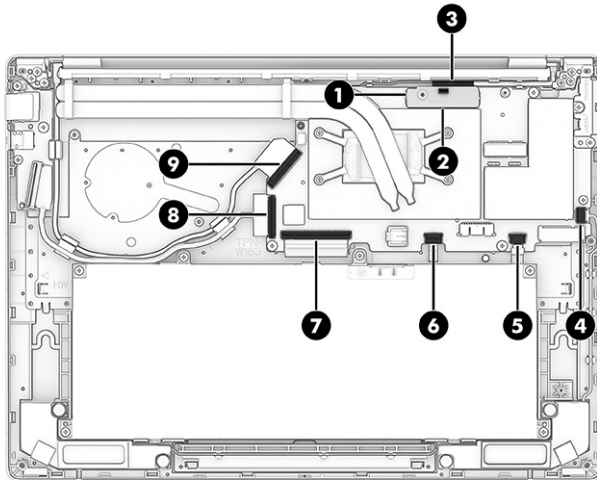

2. Remove the six Phillips M2.0 × 3.0 screws from the system board.

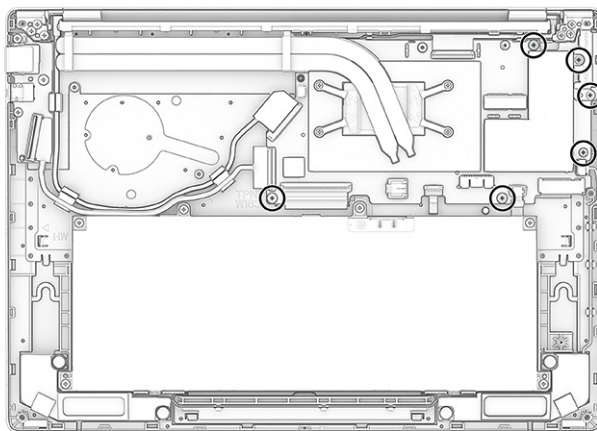

3. Lift the left side of the system board (1) up, and then pull the board (2) away from the connectors to remove it.

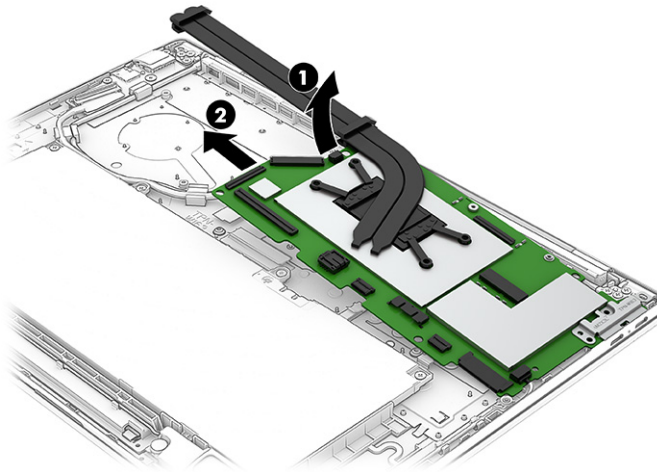

4. Pull the USB bracket off the system board. If replacing the system board, be sure to install the bracket onto the new board.

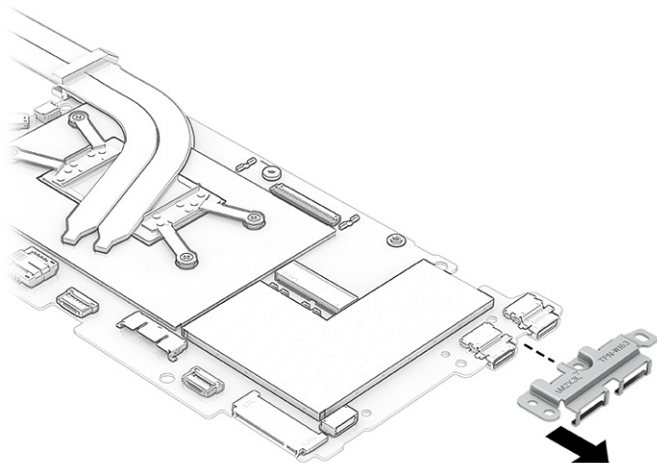

To install the system board, reverse this procedure.

Display assembly

To remove and disassemble the display assembly, use these procedures and illustrations.

 **NOTE:** Only the entire display assembly is available as a spare part. Future repair strategy might change to display components available only at the subcomponent level, in which case the entire display assembly would not be available as a spare part. Be sure to check on the display spare part strategy prior to starting the repair process.

Table 5-12 Display assembly descriptions and part numbers

Description	Spare part number
Display assembly, full hinge up, meteor silver	P12803-001
Display assembly, full hinge up, ceramic white	P12804-001

Before removing the display panel, follow these steps:

1. Prepare the computer for disassembly (see [Preparation for disassembly on page 25](#)).
2. Remove the bottom cover (see [Bottom cover on page 25](#)).
3. Remove the battery (see [Battery on page 26](#)).
4. Remove the WLAN module (see [WLAN module on page 35](#)).
5. Remove the system board (see [System board on page 39](#)).

Remove the display assembly:

1. Remove the antenna cable (1) from its routing path along the top of the computer.
2. Remove the three Phillips M2.5 × 3.0 screws (2) from each hinge.
3. Open the display (3) to 90°.
4. Separate the display (4) from the computer.

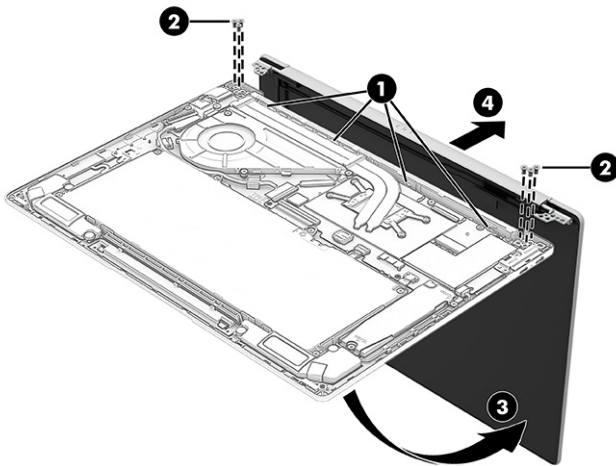

5. Remove the display panel:
 - a. Insert and pull a tool (1) along the length of the seam at the bottom of the display assembly.

- b. Pull the panel (2) away from the display back cover enough to access the stretchable tape that secures both sides of the panel.



- c. The display panel is secured to the display enclosure with tape that is installed under the left and right sides of the panel. To remove the panel, use tweezers (1) to grasp the end of the tape. Pull the tape (2) out from behind the display panel. You must pull the tape multiple times before it is completely removed.



NOTE: Pull the tape out slowly and evenly to prevent it from breaking prematurely.

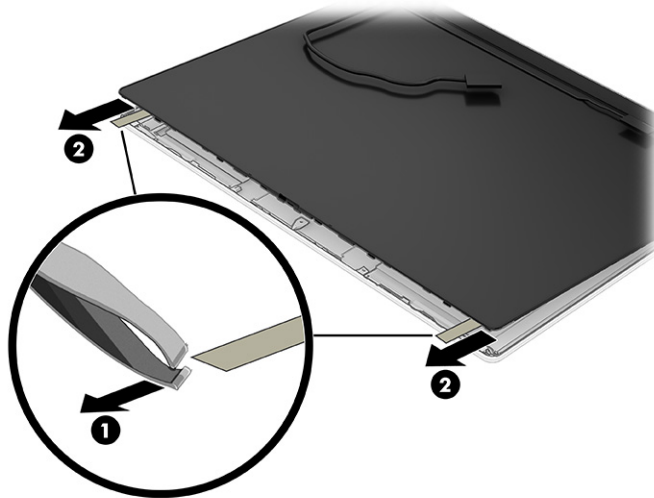

- d. Pull the panel away from the display back cover.

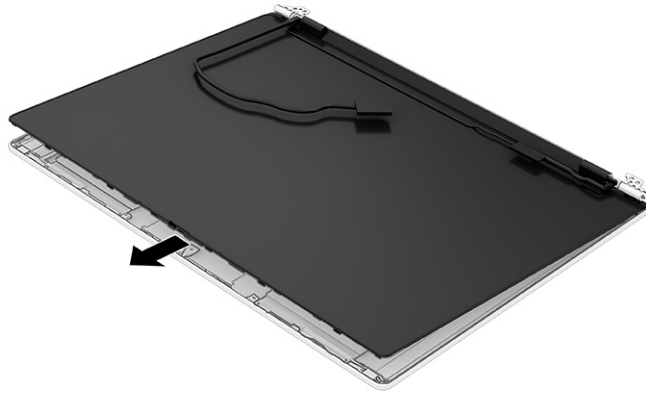

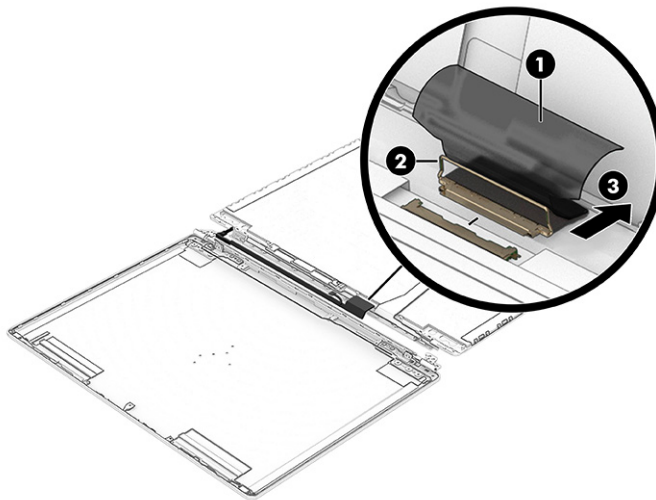

- e. Lift the tape (1) from the display panel connector.
- f. Lift the locking arm (2) off the connector.
- g. Pull the cable (3) out of the connector.

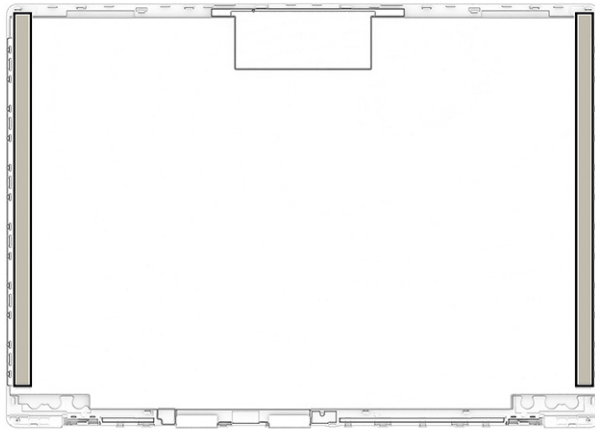

- h. When installing a display panel, use the following illustration to determine tape installation locations on the inside of the display rear cover.

 **NOTE:** When installing the tape onto the display rear cover, be sure that the end of the tape is visible and accessible, and extends out slightly from under the installed display panel.



 **NOTE:** When replacing the touch control board or display panel, be sure to update the touch firmware, available on the [HP product support](#) page.

6. Remove the camera module:
 - a. Peel the silver foil tape (1) off the back of the display panel.
 - b. Peel the cable (2) off the back of the panel.
 - c. Lift the camera module and cable (3) off the panel.

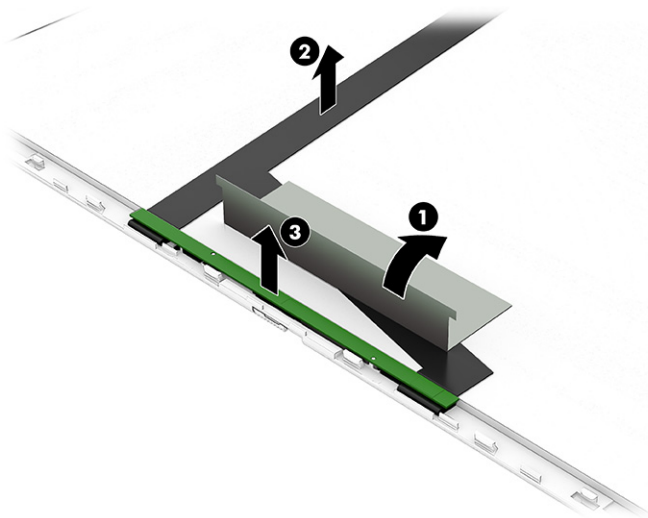

- d. Disconnect the cables from the ZIF connectors on the camera module.

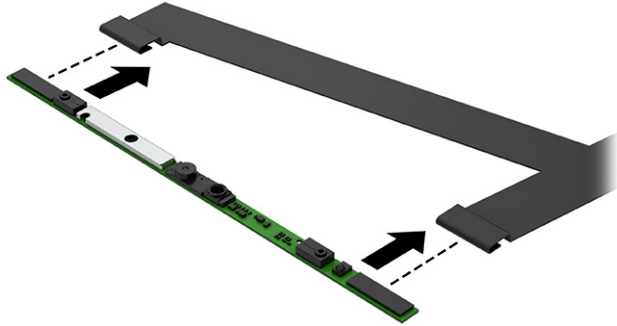

7. Remove the hinges:

- a. Remove the three Phillips M2.0 × 3.0 screws (1) and the two Phillips M2.0 × 2.0 screws (2) from each hinge.
- b. Remove the hinges (3).

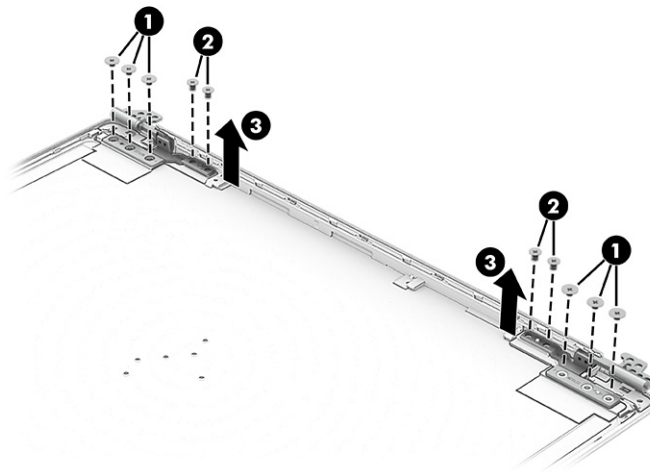

8. Remove the touch control board:

- a. Disconnect the cable from the ZIF connector (1) on the end of the board.
- b. Disconnect the two cables from the ZIF connectors (2) on the board.

- c. Peel the board (3) off the panel. The board is attached with double-sided adhesive.

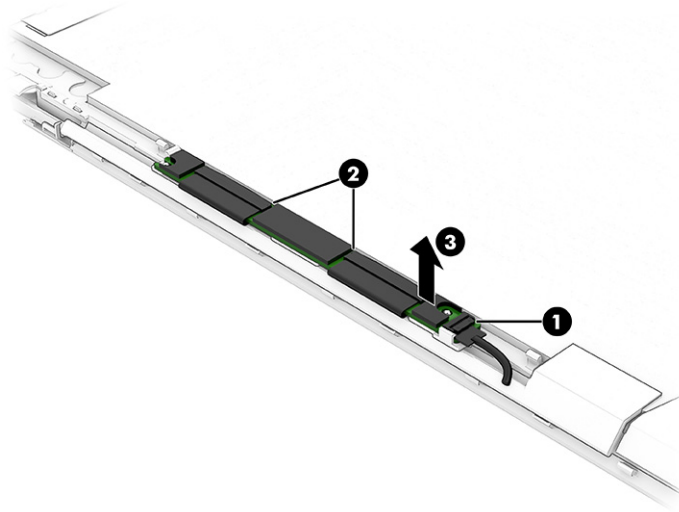

 **NOTE:** When replacing the touch control board or display panel, be sure to update the touch firmware, available on the [HP product support](#) page.

- 9. Remove the wireless antennas:
 - a. Remove the antenna cables from the clips (1) on the sides of the display back cover.
 - b. Peel the antennas (2) off the display rear cover.

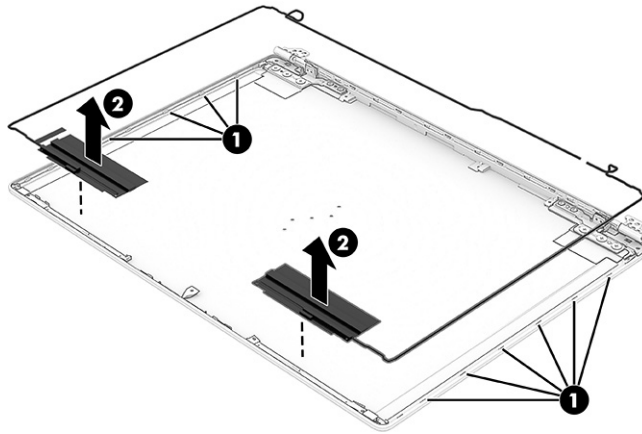

To reassemble and replace the display assembly, reverse these procedures.

Top cover with keyboard

The top cover with keyboard remains after removing all other spare parts from the computer. In this section, the first table provides the main spare part number for the top cover with keyboard. The second table provides the country codes.

Table 5-13 Top cover with keyboard descriptions and part numbers

Description	Spare part number
Meteor silver top cover, soft gray keyboard	N99794-xx1
Ceramic white top cover, ceramic white keyboard	P02386-xx1

Table 5-14 Spare part country codes

For use in country or region	Spare part number	For use in country or region	Spare part number
Belgium	-A41	Portugal	-131
Czech Republic/Slovakia	-FL1	Romania	-271
Denmark, Finland, and Norway	-DH1	Saudi Arabia	-171
French Canada	-DB1	South Korea	-AD1
France	-051	Spain	-071
Germany	-041	Thailand	-281
Greece	-151	United Kingdom	-031
International	-B31	United States	-001
Italy	-061		

6 Using Setup Utility (BIOS)

Setup Utility, or Basic Input/Output System (BIOS), controls communication between all the input and output devices on the system (such as disk drives, display, keyboard, mouse, and printer). Setup Utility (BIOS) includes settings for the types of devices installed, the startup sequence of the computer, and the amount of system and extended memory.

 **NOTE:** To start Setup Utility on convertible computers, your computer must be in notebook mode and you must use the keyboard attached to your notebook.

Starting Setup Utility (BIOS)

You have several ways to access the Setup Utility (BIOS).

 **IMPORTANT:** Use extreme care when making changes in Setup Utility (BIOS). Errors can prevent the computer from operating properly.

Use one of these options:

- Turn on or restart the computer and quickly press **f10**.
- Turn on or restart the computer, quickly press **esc**, and then press **f10** when the Start menu is displayed.

Updating Setup Utility (BIOS)

Updated versions of Setup Utility (BIOS) might be available on the HP website. Most BIOS updates on the HP website are packaged in compressed files called *SoftPaqs*. Some download packages contain a file named `Readme.txt`, which contains information regarding installing and troubleshooting the file.

Determining the BIOS version

To decide whether you need to update Setup Utility (BIOS), first determine the BIOS version on your computer.

To reveal the BIOS version information (also known as *ROM date* and *System BIOS*), use one of these options.

- HP Support Assistant
 1. Select the **Search** icon in the taskbar, type `support` in the search box, and then select the **HP Support Assistant** app.
- or -
Select the question mark icon in the taskbar.
 2. Under **My notebook**, select **Specifications**.
- Setup Utility (BIOS)
 1. Start Setup Utility (BIOS) (see [Starting Setup Utility \(BIOS\) on page 49](#)).

2. Select **Main**, and then make note of the BIOS version.
 3. Select **Exit**, select one of the options, and then follow the on-screen instructions.
- In Windows, press **ctrl+alt+s**.

To check for later BIOS versions, see [Preparing for a BIOS update on page 50](#).

Preparing for a BIOS update

Be sure to follow all prerequisites before downloading and installing a BIOS update.



IMPORTANT: To reduce the risk of damage to the computer or an unsuccessful installation, download and install a BIOS update only when the computer is connected to reliable external power using the HP AC adapter provided with the computer (select products only), a replacement AC adapter provided by HP, or an AC adapter with the power rating specified on the product label. Do not download or install a BIOS update while the computer is running on battery power, docked in an optional docking device, or connected to an optional power source. During the download and installation, follow these instructions:

- Do not disconnect power from the computer by unplugging the power cord from the AC outlet.
- Do not shut down the computer or initiate Sleep.
- Do not insert, remove, connect, or disconnect any device, cable, or cord.



NOTE: If your computer is connected to a network, consult the network administrator before installing any software updates, especially system BIOS updates.

Downloading a BIOS update

After you review the prerequisites, you can check for and download BIOS updates.

1. Perform one of these tasks:
 - Select the **Search** icon in the taskbar, type `support` in the search box, and then select the **HP Support Assistant** app.
 - Select the question mark icon in the taskbar.
2. Select **Updates**. The **Checking for Updates** window opens, and Windows checks for updates.
3. Follow the on-screen instructions.
4. At the download area, follow these steps:
 - a. Identify the most recent BIOS update and compare it to the BIOS version currently installed on your computer. If the update is more recent than your BIOS version, make a note of the date, name, or other identifier. You might need this information to locate the update later, after it has been downloaded to your hard drive.
 - b. Follow the on-screen instructions to download your selection to the hard drive.

Make a note of the path to the location on your hard drive where the BIOS update is downloaded. You will need to access this path when you are ready to install the update.

Installing a BIOS update

BIOS installation procedures vary. Follow any instructions that appear on the screen after the download is complete. If no instructions appear, follow these steps.

1. Select the **Search** icon in the taskbar, type `file` in the search box, and then select **File Explorer**.
2. Select your hard drive designation. The hard drive designation is typically Local Disk (C:).
3. Using the hard drive path you recorded earlier, open the folder that contains the update.
4. Double-click the file that has an `.exe` extension (for example, *filename.exe*).

The BIOS installation begins.

5. Complete the installation by following the on-screen instructions.



NOTE: After a message on the screen reports a successful installation, you can delete the downloaded file from your hard drive.

7 Backing up, restoring, and recovering

You can use Windows tools or HP software to back up your information, create a restore point, reset your computer, create recovery media, or restore your computer to its factory state. Performing these standard procedures can return your computer to a working state faster.

 **IMPORTANT:** If you are performing recovery procedures on a tablet, the tablet battery must be at least 70% charged before you start the recovery process.

 **IMPORTANT:** For a tablet with a detachable keyboard, connect the tablet to the keyboard base before beginning any recovery process.

Backing up information and creating recovery media

These methods of creating recovery media and backups are available on select products only.

Using Windows tools for backing up

HP recommends that you back up your information immediately after initial setup. You can do this task either using Windows Backup locally with an external USB flash drive or using online tools.

 **NOTE:** If computer storage is 32 GB or less, Microsoft System Restore is disabled by default.

Using the HP Cloud Recovery Download Tool to create recovery media (select products only)

You can use the HP Cloud Recovery Download Tool to create HP Recovery media on a bootable USB flash drive.

For details:

- Go to <http://www.hp.com>, search for HP Cloud Recovery, and then select the result that matches the type of computer that you have.

 **NOTE:** If you cannot create recovery media yourself, contact support to obtain recovery discs. Go to <http://www.hp.com/support>, select your country or region, and then follow the on-screen instructions.

 **IMPORTANT:** HP recommends that you follow the [Restoring and recovery methods on page 53](#) to restore your computer before you obtain and use the HP recovery discs. Using a recent backup can return your machine to a working state sooner than using the HP recovery discs. After the system is restored, reinstalling all the operating system software released since your initial purchase can be a lengthy process.

Restoring and recovering your system

You have several tools available to recover your system both within and outside of Windows if the desktop cannot load.

HP recommends that you attempt to restore your system using the [Restoring and recovery methods on page 53](#).

Creating a system restore

System Restore is available in Windows. The System Restore software can automatically or manually create restore points, or snapshots, of the system files and settings on the computer at a particular point.

When you use System Restore, it returns your computer to its state at the time you made the restore point. Your personal files and documents should not be affected.

Restoring and recovery methods

After you run the first method, test to see whether the issue still exists before you proceed to the next method, which might now be unnecessary.

1. Run a Microsoft System Restore.
2. Run Reset this PC.

 **NOTE:** The options **Remove everything** and then **Fully clean the drive** can take several hours to complete and leave no information on your computer. It is the safest way to reset your computer before you recycle it.

3. Recover using HP Recovery media. For more information, see [Recovering using HP Recovery media on page 53](#).

For more information about the first two methods, see the Get Help app:

- Select the **Start** button, select **All apps**, select the **Get Help** app, and then enter the task you want to perform.

 **NOTE:** You must be connected to the internet to access the Get Help app.

Recovering using HP Recovery media

You can use HP Recovery media to recover the operating system and drivers that were installed at the factory. On select products, you can create recovery media on a bootable USB flash drive using the HP Cloud Recovery Download Tool.

For details, see [Using the HP Cloud Recovery Download Tool to create recovery media \(select products only\) on page 52](#).

 **NOTE:** If you cannot create recovery media yourself, contact support to obtain recovery discs. Go to <http://www.hp.com/support>, select your country or region, and then follow the on-screen instructions.

To recover your system:

- Insert the HP Recovery media, and then restart the computer.

 **NOTE:** HP recommends that you follow the [Restoring and recovery methods on page 53](#) to restore your computer before you obtain and use the HP recovery discs. Using a recent backup can return your machine to a working state sooner than using the HP recovery discs. After the system is restored, reinstalling all the operating system software released since your initial purchase can be a lengthy process.

Changing the computer boot order

If your computer does not restart using the HP Recovery media, you can change the computer boot order, which is the order of devices listed in BIOS for startup information. You can select an optical drive or a USB flash drive, depending on the location of your HP Recovery media.

 **IMPORTANT:** For a tablet with a detachable keyboard, connect the tablet to the keyboard base before beginning these steps.

To change the boot order:

1. Insert the HP Recovery media.
2. Access the system **Startup** menu.
 - For computers or tablets with keyboards attached, turn on or restart the computer or tablet, quickly press **esc**, and then press **f9** for boot options.
 - For tablets without keyboards, turn on or restart the tablet, and then quickly press and hold one of the following buttons:
 - Volume up
 - Volume down

Then select **f9**.
3. Select the optical drive or USB flash drive from which you want to boot, and then follow the on-screen instructions.

Using HP Sure Recover (select products only)

Select computer models are configured with HP Sure Recover, a PC operating system (OS) recovery solution built into the hardware and software. HP Sure Recover can fully restore the HP OS image without installed recovery software.

Using HP Sure Recover, an administrator or user can restore the system and install:

- Latest version of the operating system
- Platform-specific device drivers
- Software applications, in the case of a custom image

To access the latest documentation for HP Sure Recover, go to <http://www.hp.com/support>. Follow the on-screen instructions to find your product and locate your documentation.

8 Using HP PC Hardware Diagnostics

You can use the HP PC Hardware Diagnostics utility to determine whether your computer hardware is running properly. The three versions are HP PC Hardware Diagnostics Windows, HP PC Hardware Diagnostics UEFI (Unified Extensible Firmware Interface), and (for select products only) Remote HP PC Hardware Diagnostics UEFI, a firmware feature.

Using HP PC Hardware Diagnostics Windows (select products only)

HP PC Hardware Diagnostics Windows is a Windows-based utility that allows you to run diagnostic tests to determine whether the computer hardware is functioning properly. The tool runs within the Windows operating system to diagnose hardware failures.

If HP PC Hardware Diagnostics Windows is not installed on your computer, you must download and install it. To download HP PC Hardware Diagnostics Windows, see [Downloading HP PC Hardware Diagnostics Windows on page 56](#).

Using an HP PC Hardware Diagnostics Windows hardware failure ID code

When HP PC Hardware Diagnostics Windows detects a failure that requires hardware replacement, a 24-digit failure ID code is generated for select component tests. For interactive tests, such as keyboard, mouse, or audio and video palette, you must perform troubleshooting steps before you can receive a failure ID.

You have several options after you receive a failure ID:

- Select **Next** to open the Event Automation Service (EAS) page, where you can log the case.
- Scan the QR code with your mobile device, which takes you to the EAS page, where you can log the case.
- Select the box next to the 24-digit failure ID to copy your failure code and send it to support.

Accessing HP PC Hardware Diagnostics Windows

After HP PC Hardware Diagnostics Windows is installed, you can access it from HP Support Assistant or the Start menu.

Accessing HP PC Hardware Diagnostics Windows from HP Support Assistant

After HP PC Hardware Diagnostics Windows is installed, follow these steps to access it from HP Support Assistant:

1. Complete one of the following tasks:
 - Select the **Search** icon in the taskbar, type `support` in the search box, and then select the **HP Support Assistant** app.
 - Select the question mark icon in the taskbar.
2. Select **Fixes & Diagnostics**.

3. Select **Run hardware diagnostics**, and then select **Launch**.
4. When the tool opens, select the type of diagnostic test that you want to run, and then follow the on-screen instructions.

 **NOTE:** To stop a diagnostic test, select **Cancel**.

Accessing HP PC Hardware Diagnostics Windows from the Start menu (select products only)

After HP PC Hardware Diagnostics Windows is installed, follow these steps to access it from the Start menu:

1. Select the **Start** button, and then select **All apps**.
2. Select **HP PC Hardware Diagnostics Windows**.
3. When the tool opens, select the type of diagnostic test that you want to run, and then follow the on-screen instructions.

 **NOTE:** To stop a diagnostic test, select **Cancel**.

Downloading HP PC Hardware Diagnostics Windows

The HP PC Hardware Diagnostics Windows downloading instructions are provided in English only. You must use a Windows computer to download this tool because only .exe files are provided.

Downloading the latest HP PC Hardware Diagnostics Windows version from HP

To download HP PC Hardware Diagnostics Windows from HP, follow these steps:

1. Go to <http://www.hp.com/go/techcenter/pcdiags>. The HP PC Diagnostics home page is displayed.
2. Select **Download HP Diagnostics Windows**, and then select the specific Windows diagnostics version to download to your computer or a USB flash drive.

The tool downloads to the selected location.

Downloading the HP PC Hardware Diagnostics Windows from the Microsoft Store

You can download the HP PC Hardware Diagnostics Windows from the Microsoft Store:

1. Select the Microsoft Store app on your desktop or select the **Search** icon in the taskbar, and then type `Microsoft Store` in the search box.
2. Type `HP PC Hardware Diagnostics Windows` in the **Microsoft Store** search box.
3. Follow the on-screen directions.

The tool downloads to the selected location.

Downloading HP Hardware Diagnostics Windows by product name or number (select products only)

You can download HP PC Hardware Diagnostics Windows by product name or number.

 **NOTE:** For some products, you might have to download the software to a USB flash drive by using the product name or number.

1. Go to <http://www.hp.com/support>.
2. Select **Software and Drivers**, select your type of product, and then enter the product name or number in the search box that is displayed.
3. In the **Diagnostics** section, select **Download**, and then follow the on-screen instructions to select the specific Windows diagnostics version to be downloaded to your computer or USB flash drive.

The tool downloads to the selected location.

Installing HP PC Hardware Diagnostics Windows

To install HP PC Hardware Diagnostics Windows, navigate to the folder on your computer or the USB flash drive where the .exe file downloaded, double-click the .exe file, and then follow the on-screen instructions.

Using HP PC Hardware Diagnostics UEFI

HP PC Hardware Diagnostics Unified Extensible Firmware Interface (UEFI) allows you to run diagnostic tests to determine whether the computer hardware is functioning properly. The tool runs outside the operating system so that it can isolate hardware failures from issues that are caused by the operating system or other software components.



NOTE: For some products, you must use a Windows computer and a USB flash drive to download and create the HP UEFI support environment because only .exe files are provided. For more information, see [Downloading HP PC Hardware Diagnostics UEFI to a USB flash drive on page 58](#).

If your PC does not start in Windows, you can use HP PC Hardware Diagnostics UEFI to diagnose hardware issues.

Using an HP PC Hardware Diagnostics UEFI hardware failure ID code

When HP PC Hardware Diagnostics UEFI detects a failure that requires hardware replacement, a 24-digit failure ID code is generated.

For assistance in solving the problem, complete one of these tasks:

- Select **Contact HP**, accept the HP privacy disclaimer, and then use a mobile device to scan the failure ID code that appears on the next screen. The HP Customer Support - Service Center page appears with your failure ID and product number automatically filled in. Follow the on-screen instructions.
- Contact support, and provide the failure ID code.

Starting HP PC Hardware Diagnostics UEFI

To start HP PC Hardware Diagnostics UEFI, follow this procedure.

1. Turn on or restart the computer, and quickly press **esc**.
2. Press **f2**.

The BIOS searches three places for the diagnostic tools, in the following order:

- a. Connected USB flash drive



NOTE: To download the HP PC Hardware Diagnostics UEFI tool to a USB flash drive, see [Downloading the latest HP PC Hardware Diagnostics UEFI version on page 59](#).

- b. Hard drive
 - c. BIOS
3. When the diagnostic tool opens, select the type of diagnostic test that you want to run, and then follow the on-screen instructions.

Starting HP PC Hardware Diagnostics UEFI through HP Hotkey Support software (select products only)

This section describes how to start HP PC Hardware Diagnostics UEFI through HP Hotkey Support software.



NOTE: You must disable fast boot to access HP PC Hardware Diagnostics UEFI from the HP System Information application.

To disable fast boot:

1. Turn on or restart the computer, and when the HP logo appears, press **f10** to enter Computer Setup.
2. Select **Advanced**, and then select **Boot Options**.
3. Clear **Fast Boot**.
4. Select **Save Changes and Exit**, and then select **Yes**.

To start HP PC Hardware Diagnostics UEFI through HP Hotkey Support software, follow this procedure:

1. From the **Start** menu, open the HP System Information Application or press **fn+esc**.
2. In HP System Information screen, select **Run System Diagnostics**, select **Yes** to run the application, and then select **Restart**.



IMPORTANT: To prevent loss of data, save your work in all open apps before restarting your computer.



NOTE: When the restart is complete, the computer opens the HP PC Hardware Diagnostics UEFI Application. Proceed with the troubleshooting tests.

Downloading HP PC Hardware Diagnostics UEFI to a USB flash drive

Downloading HP PC Hardware Diagnostics UEFI to a USB flash drive can be useful in some situations.

- HP PC Hardware Diagnostics UEFI is not included in the preinstallation image.
- HP PC Hardware Diagnostics UEFI is not included in the HP Tool partition.
- The hard drive is damaged.



NOTE: The HP PC Hardware Diagnostics UEFI downloading instructions are provided in English only, and you must use a Windows computer to download and create the HP UEFI support environment because only `.exe` files are provided.

Downloading the latest HP PC Hardware Diagnostics UEFI version

To download the latest HP PC Hardware Diagnostics UEFI version to a USB flash drive, follow this procedure:

1. Go to <http://www.hp.com/go/techcenter/pcdiags>. The HP PC Diagnostics home page is displayed.
2. Select **Download HP Diagnostics UEFI**, and then select **Run**.

Downloading HP PC Hardware Diagnostics UEFI by product name or number (select products only)

You can download HP PC Hardware Diagnostics UEFI by product name or number (select products only) to a USB flash drive.



NOTE: For some products, you might have to download the software to a USB flash drive by using the product name or number.

1. Go to <http://www.hp.com/support>.
2. Enter the product name or number, select your computer, and then select your operating system.
3. In the **Diagnostics** section, follow the on-screen instructions to select and download the specific UEFI Diagnostics version for your computer.

Using Remote HP PC Hardware Diagnostics UEFI settings (select products only)

Remote HP PC Hardware Diagnostics UEFI is a firmware (BIOS) feature that downloads HP PC Hardware Diagnostics UEFI to your computer. It can then run the diagnostics on your computer, and it might upload results to a preconfigured server.

For more information about Remote HP PC Hardware Diagnostics UEFI, go to <http://www.hp.com/go/techcenter/pcdiags>, and then select **Find out more**.

Downloading Remote HP PC Hardware Diagnostics UEFI

Remote HP PC Hardware Diagnostics UEFI is also available as a SoftPaq that you can download to a server.

Downloading the latest Remote HP PC Hardware Diagnostics UEFI version

You can download the latest Remote HP PC Hardware Diagnostics UEFI version to a USB flash drive.

1. Go to <http://www.hp.com/go/techcenter/pcdiags>. The HP PC Diagnostics home page is displayed.
2. Select **Download Remote Diagnostics**, and then select **Run**.

Downloading Remote HP PC Hardware Diagnostics UEFI by product name or number

You can download Remote HP PC Hardware Diagnostics UEFI by product name or number.



NOTE: For some products, you might have to download the software by using the product name or number.

1. Go to <http://www.hp.com/support>.

2. Select **Software and Drivers**, select your type of product, enter the product name or number in the search box that is displayed, select your computer, and then select your operating system.
3. In the **Diagnostics** section, follow the on-screen instructions to select and download the **Remote UEFI** version for the product.

Customizing Remote HP PC Hardware Diagnostics UEFI settings

Using the Remote HP PC Hardware Diagnostics setting in Computer Setup (BIOS), you can perform several customizations.

- Set a schedule for running diagnostics unattended. You can also start diagnostics immediately in interactive mode by selecting **Execute Remote HP PC Hardware Diagnostics UEFI**.
- Set the location for downloading the diagnostic tools. This feature provides access to the tools from the HP website or from a server that has been preconfigured for use. Your computer does not require the traditional local storage, such as a hard drive or USB flash drive, to run remote diagnostics.
- Set a location for storing the test results. You can also set the user name and password that you use for uploads.
- Display status information about the diagnostics run previously.

To customize Remote HP PC Hardware Diagnostics UEFI settings, follow these steps:

1. Turn on or restart the computer, and when the HP logo appears, press **f10** to enter Computer Setup.
2. Select **Advanced**, and then select **Settings**.
3. Make your customization selections.
4. Select **Main**, then select **Save Changes and Exit** to save your settings.

Your changes take effect when the computer restarts.

9 Specifications

This chapter provides specifications for your computer system.

Computer specifications

This section provides specifications for your computer. When you travel with your computer, the computer dimensions and weights, as well as input power ratings and operating specifications, provide helpful information.

Table 9-1 Computer specifications

	Metric	U.S.
Dimensions		
Width	312.9 mm	12.32 in
Depth	223.5 mm	8.80 in
Height (front)	14.3 mm	0.56 in
Height (back)	14.4 mm	0.57 in
Weight		
	1349.4 g	2.98 lb
Input power		
Operating voltage and current	5 V DC @ 3 A / 9 V DC @ 3 A / 12 V DC @ 5 A / 15 V DC @ 4.33 A / 20 V DC @ 3.25 A - 65 W USB-C	
	5 V DC @ 3 A / 9 V DC @ 3 A / 10 V DC @ 5 A / 12 V DC @ 5 A / 15 V DC @ 4.33 A / 20 V DC @ 3.25 A - 65 W USB-C	
Temperature		
Operating	5°C to 35°C	41°F to 95°F
Nonoperating	-20°C to 60°C	-4°F to 140°F
Relative humidity (noncondensing)		
Operating	10% to 90%	
Nonoperating	5% to 95%	
Maximum altitude (unpressurized)		
Operating	-15 m to 3,048 m	-50 ft to 10,000 ft
Nonoperating	-15 m to 12,192 m	-50 ft to 40,000 ft



NOTE: Applicable product safety standards specify thermal limits for plastic surfaces. The device operates well within this range of temperatures.

Display specifications

This section provides specifications for your display.

Table 9-2 Display specifications

	Metric	U.S.
Active diagonal size	35.6 cm	14.0 in
Resolution	2240 × 1400 (2.2 K)	
Surface treatment	Antiglare	
Brightness	300 nits	
Viewing angle	UWVA	
Backlight	WLED	
Display panel interface	eDP 1.4 + PSR2	

Solid-state drive specifications

This section provides specifications for your solid-state drives.

Table 9-3 Solid-state drive specifications

	512 GB*	1 TB*	2 TB*
Dimensions			
Height	1.0 mm	1.0 mm	1.0 mm
Length	50.8 mm	50.8 mm	50.8 mm
Width	28.9 mm	28.9 mm	28.9 mm
Weight	< 10 g	< 10 g	< 10 g
Interface type			
Ready time, maximum (to not busy)	< 1.0 ms	1.0 ms	1.0 ms
Access times, logical	0.1 ms	0.1 ms	0.1 ms
Transfer rate			
Sequential read	up to 2150 MBps	up to 2150 MBps	up to 3800 MBps
Random read	Up to 300,000 IOPs	Up to 300,000 IOPs	Up to 300,000 IOPs
Sequential write	up to 1550 MBps	up to 1550 MBps	up to 2670 MBps
Random write	Up to 100,000 IOPs	Up to 100,000 IOPs	Up to 100,000 IOPs
Total logical sectors	1,000,215,216	1,500,336,388	2,998,846
Operating temperature			
	0°C to 70°C	0°C to 70°C	0°C to 70°C
	(32°F to 158°F)	(32°F to 158°F)	(32°F to 158°F)



NOTE: *1 GB = 1 billion bytes when referring to hard drive storage capacity. Actual accessible capacity is less. Actual drive specifications might differ slightly.

Certain restrictions and exclusions apply. Contact support for details.

10 Power cord set requirements

This chapter provides power cord requirements for countries and regions.

The wide-range input feature of the computer permits it to operate from any line voltage from 100 V AC to 120 V AC, or from 220 V AC to 240 V AC.

The three-conductor power cord set included with the computer meets the requirements for use in the country or region where the equipment is purchased.

Power cord sets for use in other countries or regions must meet the requirements of the country and region where the computer is used.

Requirements for all countries

These power cord requirements are applicable to all countries and regions.

- The length of the power cord set must be at least **1.0 m** (3.3 ft) and no more than **2.0 m** (6.5 ft).
- All power cord sets must be approved by an acceptable accredited agency responsible for evaluation in the country or region where the power cord set will be used.
- The power cord sets must have a minimum current capacity of 10 A and a nominal voltage rating of 125 V AC or 250 V AC, as required by the power system of each country or region.
- The appliance coupler must meet the mechanical configuration of an EN 60 320/IEC 320 Standard Sheet C13 connector for mating with the appliance inlet on the back of the computer.

Requirements for specific countries and regions

To determine power cord requirements for specific countries and regions, use this table.

Table 10-1 Power cord requirements for specific countries and regions

Country/region	Accredited agency	Applicable note number
Argentina	IRAM	1
Australia	SAA	1
Austria	OVE	1
Belgium	CEBEC	1
Brazil	ABNT	1
Canada	CSA	2
Chile	IMQ	1
Denmark	DEMKO	1
Finland	FIMKO	1
France	UTE	1

Table 10-1 Power cord requirements for specific countries and regions (continued)

Country/region	Accredited agency	Applicable note number
Germany	VDE	1
India	BIS	1
Israel	SII	1
Italy	IMQ	1
Japan	JIS	3
Netherlands	KEMA	1
New Zealand	SANZ	1
Norway	NEMKO	1
People's Republic of China	CCC	4
Saudi Arabia	SASO	7
Singapore	PSB	1
South Africa	SABS	1
South Korea	KTL	5
Sweden	SEMKO	1
Switzerland	SEV	1
Taiwan	BSMI	6
Thailand	TISI	1
United Kingdom	ASTA	1
United States	UL	2

1. The flexible cord must be Type HO5VV-F, three-conductor, 0.75 mm² conductor size. Power cord set fittings (appliance coupler and wall plug) must bear the certification mark of the agency responsible for evaluation in the country or region where it will be used.
2. The flexible cord must be Type SVT/SJT or equivalent, No. 18 AWG, three-conductor. The wall plug must be a two-pole grounding type with a NEMA 5-15P (15 A, 125 V AC) or NEMA 6-15P (15 A, 250 V AC) configuration. CSA or C-UL mark. UL file number must be on each element.
3. The appliance coupler, flexible cord, and wall plug must bear a T mark and registration number in accordance with the Japanese Dentori Law. The flexible cord must be Type VCTF, three-conductor, 0.75 mm² or 1.25 mm² conductor size. The wall plug must be a two-pole grounding type with a Japanese Industrial Standard C8303 (7 A, 125 V AC) configuration.
4. The flexible cord must be Type RVV, three-conductor, 0.75 mm² conductor size. Power cord set fittings (appliance coupler and wall plug) must bear the CCC certification mark.
5. The flexible cord must be Type H05VV-F three-conductor, 0.75 mm² conductor size. KTL logo and individual approval number must be on each element. Approval number and logo must be printed on a flag label.
6. The flexible cord must be Type HVCTF three-conductor, 1.25 mm² conductor size. Power cord set fittings (appliance coupler, cable, and wall plug) must bear the BSMI certification mark.

7. For 127 V AC, the flexible cord must be Type SVT or SJT 3-conductor, 18 AWG, with plug NEMA 5-15P (15 A, 125 V AC), with UL and CSA or C-UL marks. For 240 V AC, the flexible cord must be Type H05VV-F three-conductor, 0.75 mm² or 1.00 mm² conductor size, with plug BS 1363/A with BSI or ASTA marks.

11 Recycling

When a nonrechargeable or rechargeable battery has reached the end of its useful life, do not dispose of the battery in general household waste. Follow the local laws and regulations in your area for battery disposal.

HP encourages customers to recycle used electronic hardware, HP original print cartridges, and rechargeable batteries. For more information about recycling programs, see the HP website at <http://www.hp.com/recycle>.

Index

- A**
 - AC adapter and battery light, identifying 5
 - AC adapters, spare part numbers 15
 - action key, identifying 10
 - audio-out (headphone)/audio-in (microphone) combo jack, identifying 4
 - audio, product description 1
- B**
 - backup, creating 52
 - backups 52
 - battery
 - illustrated 14
 - spare part number 14
 - BIOS
 - determining version 49
 - downloading an update 50
 - starting the Setup Utility 49
 - updating 49
 - Bluetooth label 12
 - boot order, changing 54
 - bottom components 11
 - bottom cover
 - illustrated 15
 - removal 25
 - spare part number 15, 25
 - buttons
 - left touchpad 8
 - power 11
 - right touchpad 8
- C**
 - camera
 - identifying 7
 - camera light, identifying 7
 - camera privacy cover, identifying 7
 - caps lock light 9
 - caring for your computer 20
 - cautions
 - electrostatic discharge 16, 17
 - cleaning your computer 20
 - caring for wood veneer 22
 - disinfecting 21
 - HP Easy Clean 20
 - removing dirt and debris 20
 - components
 - bottom 11
 - display 6
 - keyboard area 7
 - left side 4
 - lights 8
 - right side 4
 - touchpad 7, 8
 - computer major components 13
 - computer specifications 61
 - connectors
 - power 5
 - control zone 8
- D**
 - display
 - specifications 61, 62
 - display components 6
 - display panel
 - product description 1
- E**
 - electrostatic discharge (ESD) 16, 17
 - preventing damage 16-18
 - esc key, identifying 10
- F**
 - fan
 - illustrated 14
 - removal 34
 - spare part number 14, 34
 - fn key, identifying 10
 - fn lock light, identifying 9
- G**
 - graphics, product description 1
 - grounding methods 16-18
 - guidelines
 - packaging 16, 22
 - transporting 16, 22
 - workstation 16
- H**
 - hard drive
 - product description 1
 - specifications 61
 - heat sink
 - illustrated 14
 - removal 38
 - spare part number 14, 38
 - HP PC Hardware Diagnostics UEFI
 - downloading 58
 - failure ID code 57
 - HP Hotkey Support software 58
 - starting 57, 58
 - using 57
 - HP PC Hardware Diagnostics Windows
 - accessing 55, 56
 - downloading 56
 - failure ID code 55
 - installing 57
 - using 55
 - HP Recovery media
 - recovery 53
 - HP Sure Recover 54
- I**
 - illustrated parts catalog 13
 - internal microphones, identifying 7
- J**
 - jacks
 - audio-out (headphone)/audio-in (microphone) 4
- K**
 - keyboard
 - product description 2
 - keyboard with top cover
 - spare part numbers 47
 - keys
 - action 10
 - esc 10
 - fn 10
 - Windows 10
 - Windows Copilot 10

L

- labels
 - Bluetooth 12
 - regulatory 12
 - serial number 12
 - service 12
 - wireless certification 12
 - WLAN 12
- left control zone, identifying 8
- left side components 4
- lights
 - AC adapter and battery 5
 - camera 7
 - caps lock 9
 - fn lock 9
 - microphone mute 9
 - mute 9
 - power 9
 - touchpad 8
- low blue light mode 6

M

- memory module
 - product description 1
- microphone
 - product description 1
- microphone mute light, identifying 9
- miscellaneous parts 15
- model name 1
- mute light, identifying 9

O

- operating system, product description 2

P

- packaging guidelines 16, 22
- pointing device, product description 2
- port with HP Sleep and Charge, identifying 4
- ports
 - product description 2
 - USB Type-C power connector and port with HP Sleep and Charge and DisplayPort output 5
 - USB with HP Sleep and Charge 4
- power button, identifying 11
- power connector
 - identifying 5

- power cord
 - requirements for all countries 64
 - requirements for specific countries and regions 64
 - set requirements 64
- power cords, spare part numbers 15
- power light, identifying 9
- power requirements, product description 2
- primary storage
 - product description 1
- processor
 - product description 1
- product description
 - audio 1
 - display panel 1
 - graphics 1
 - hard drive 1
 - keyboard 2
 - memory module 1
 - microphone 1
 - operating system 2
 - pointing device 2
 - ports 2
 - power requirements 2
 - primary storage 1
 - processors 1
 - product name 1
 - security 2
 - serviceability 3
 - solid-state drive 1
 - video 1
 - wireless 1
- product name 1
- product name and number, computer 12

R

- recovery 52
 - discs 53
 - media 53
 - USB flash drive 53
- recovery media 52
 - creating using HP Cloud Recovery Download Tool 52
 - creating using Windows tools 52
- regulatory information
 - regulatory label 12
 - wireless certification labels 12

- Remote HP PC Hardware Diagnostics UEFI settings
 - customizing 60
 - using 59
- removal and replacement procedures 25
- solid-state drive 28
- restoring 52
- restoring and recovery methods 53
- right control zone, identifying 8
- right side components 4
- RJ-45/audio board
 - removal 30
 - spare part numbers 30

S

- Screw Kit, spare part number 15
- security, product description 2
- serial number, computer 12
- service labels, locating 12
- serviceability, product description 3
- solid-state drive
 - illustrated 14
 - product description 1
 - removal and replacement 28
 - spare part number 14
 - specifications 62
- spare part country codes 47
- speaker
 - illustrated 15
 - removal 30
 - spare part number 15
 - spare part numbers 30
- speakers, identifying 11
- special keys
 - identifying 9
 - using 9
- specifications
 - computer 61
 - display 61, 62
 - hard drive 61
 - solid-state drive 62
- static electricity 16, 17
- support information 23
- system board
 - removal 39
 - spare part numbers 39
- system board protective cover
 - removal 33
 - spare part numbers 33
- system restore 53
- system restore point, creating 52

T

- touchpad
 - illustrated 14
 - removal 32
 - settings 7,8
 - spare part number 14
 - spare part numbers 32
- touchpad buttons
 - identifying 8
- touchpad components 7
- touchpad light, identifying 8
- touchpad settings, adjusting 7
- touchpad zone, identifying 8
- transporting guidelines 16,22
- traveling with the computer 12

U

- USB board
 - illustrated 14
 - spare part number 14
- USB Type-C power connector and port with HP Sleep and Charge and DisplayPort output, identifying 5

V

- vents, identifying 12
- video, product description 1

W

- wake-on-voice 6
- Windows
 - backup 52
 - recovery media 52
 - system restore point 52
- Windows Copilot key, identifying 10
- Windows key, identifying 10
- Windows tools, using 52
- wireless antennas, identifying 7
- wireless certification label 12
- wireless, product description 1
- WLAN antennas, identifying 7
- WLAN device 12
- WLAN label 12
- WLAN module
 - illustrated 14
 - removal 35
 - spare part number 14
 - spare part numbers 35
- workstation guidelines 16