

Wall Mount and Face Plate Instructions for Poly CCX 350, 400, 500, 505, 600, and 700

Instructions de montage mural et sur plaque murale pour les téléphones Poly CCX 350, 400, 500, 505, 600, et 700 • Wandmontage und Blendenmontage für Poly CCX 350, 400, 500, 505, 600 und 700 • Instrucciones de montaje en pared y de placa de pared para Poly CCX 350, 400, 500, 505, 600 y 700 • Instruções para montagem na parede e para a placa frontal do Poly CCX 350, 400, 500, 505, 600 and 700 • Istruzioni per il montaggio a parete e su piastra per Poly CCX 350, 400, 500, 505, 600 e 700 • Poly CCX 350, 400, 500, 505, 600 and 700 壁掛式安裝和面板安裝說明 • Poly CCX 350、400、500、505、600 與 700 壁掛架與面板安裝說明 • Poly CCX 350, 400, 500, 505, 600, 700 벽면 거치 및 면판 설치 방법 • Poly CCX 350, 400, 500, 505, 600, 700 の壁掛け設置およびフェイスプレート取り付け手順

CONTENTS

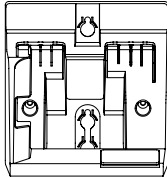

Poly CCX Wall Mount Bracket

Varies by phone model

Varie selon le modèle de téléphone utilisé • Unterscheidet sich je nach Telefonmodell • Varía según el modelo de teléfono • Varia dependendo do modelo do telefone • Varia per modello di telefono • 根据电话型号有所不同 • 依電話型號而異 • 모델에 따라 다릅니다 • 電話機モデルによって異なります



(2) 3,5 x 30 mm (0,14 x 1,18 in.)
(3) for CCX 350

(2) Plastic Wall Anchors
(3) for CCX 350

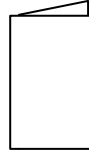

Setup Sheet



Network Cable
180 mm (7.8 in.)

TOOLS

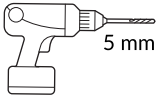

5 mm



3 mm and 5 mm

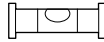

poly.com/support



CCX 350

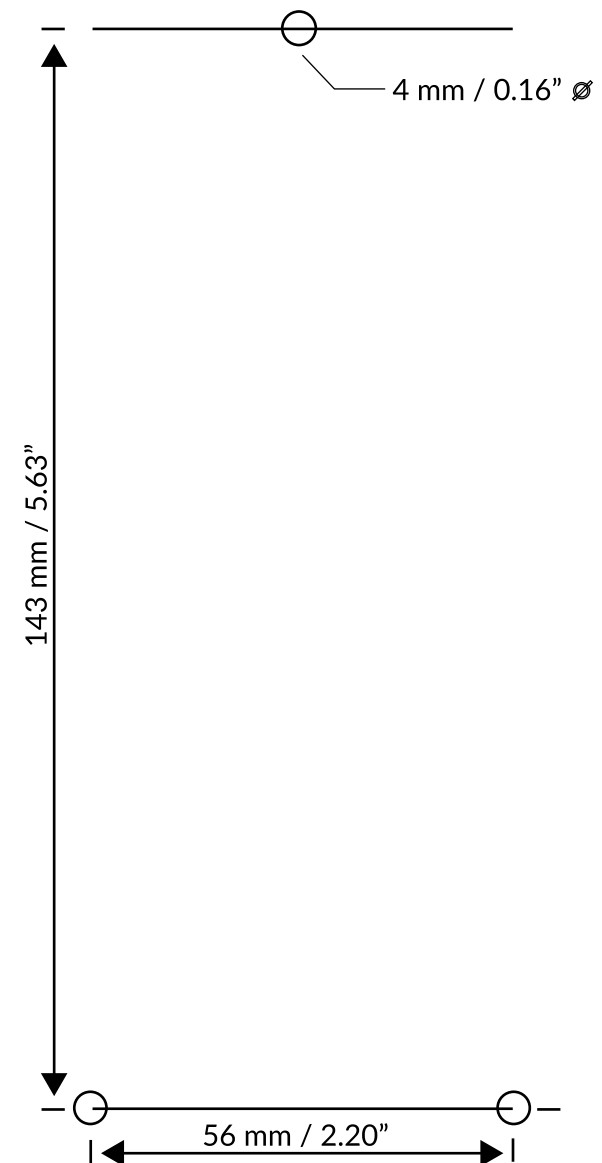

CCX 400

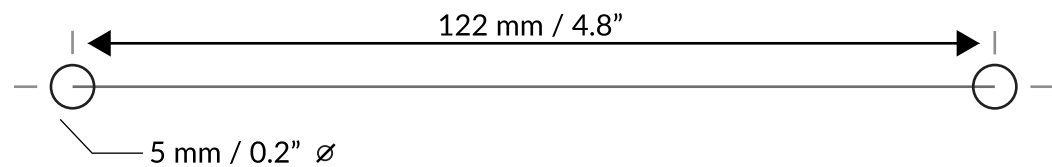

CCX 500/505

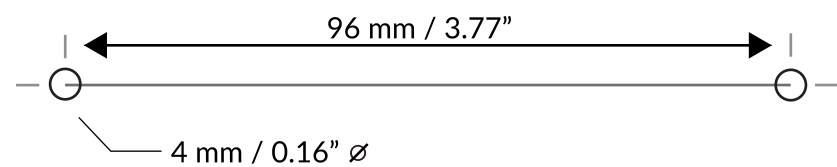

CCX 600/700

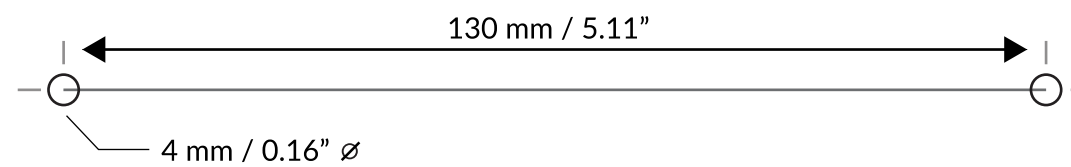

Varies by phone model

Varie selon le modèle de téléphone utilisé • Unterscheidet sich je nach Telefonmodell • Varía según el modelo de teléfono • Varia dependendo do modelo do telefone • Varia per modello di telefono • 根据电话型号有所不同 • 依電話型號而異 • 모델에 따라 다릅니다 • 電話機モデルによって異なります

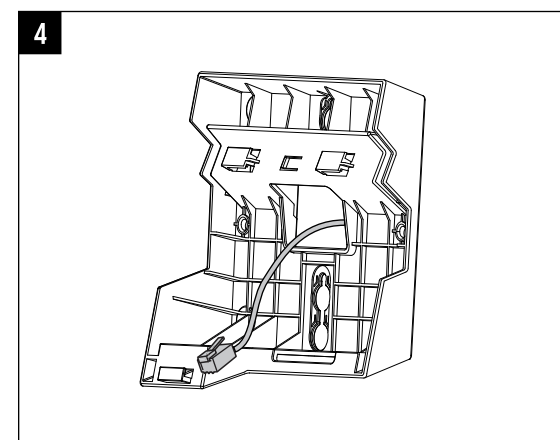
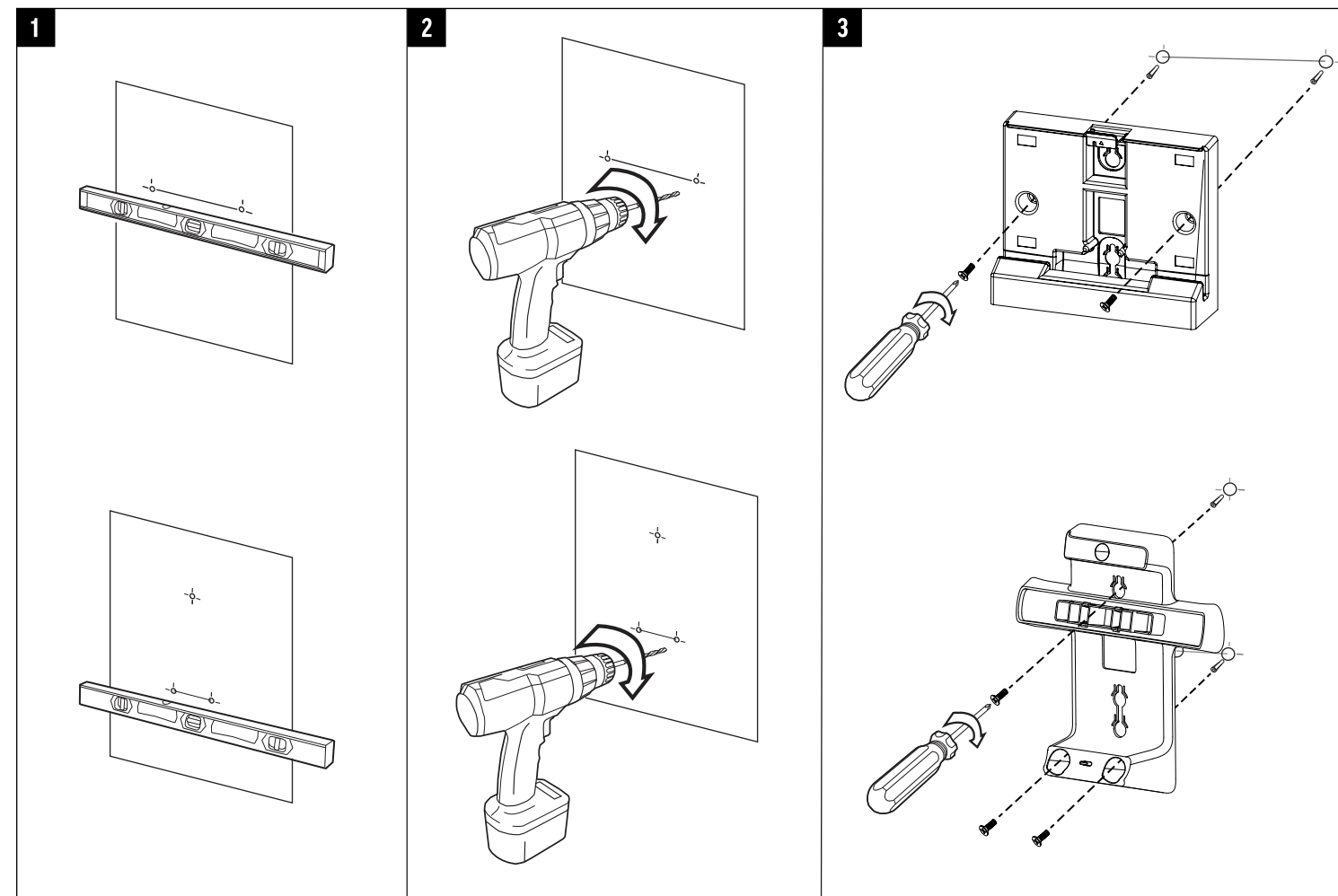

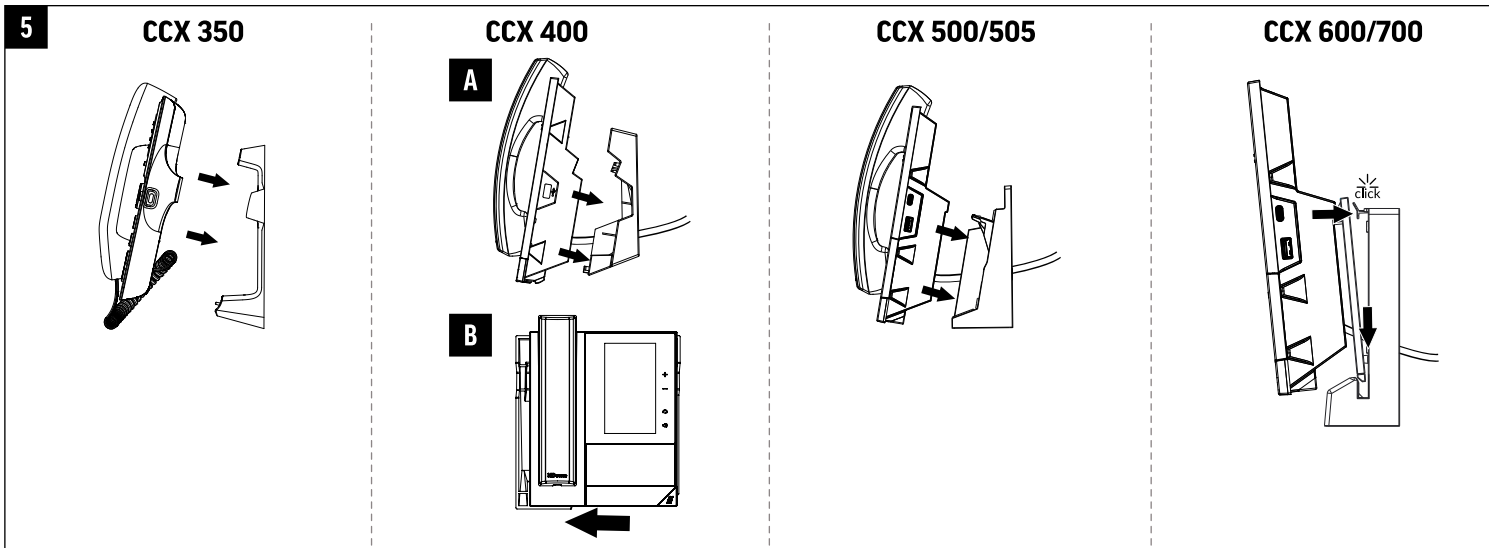

Pour éviter toute dégradation, veillez à bien raccrocher le combiné sur la base du téléphone en le clipsant sur le crochet commutateur. • Hörer in der Muschel auf der Lasche sichern, um Beschädigungen zu vermeiden. • Para evitar daños, sujete el aparato telefónico en el soporte con la presilla. • Para evitar danos, encaixe o fone na base e no gancho. • Per evitare danni, fissare il telefono al supporto e sul gancio. • 为防止损坏, 请将电话听筒固定在卡座和固定扣上。 • 为避免損壞, 請將話機掛在鞍座的固定扣上。 • 수화기가 손상되지 않도록 받침대 및 클립에 잘 고정해줍니다. • 損傷を防ぐため、ハンドセットを台に固定して、クリップで留めます。

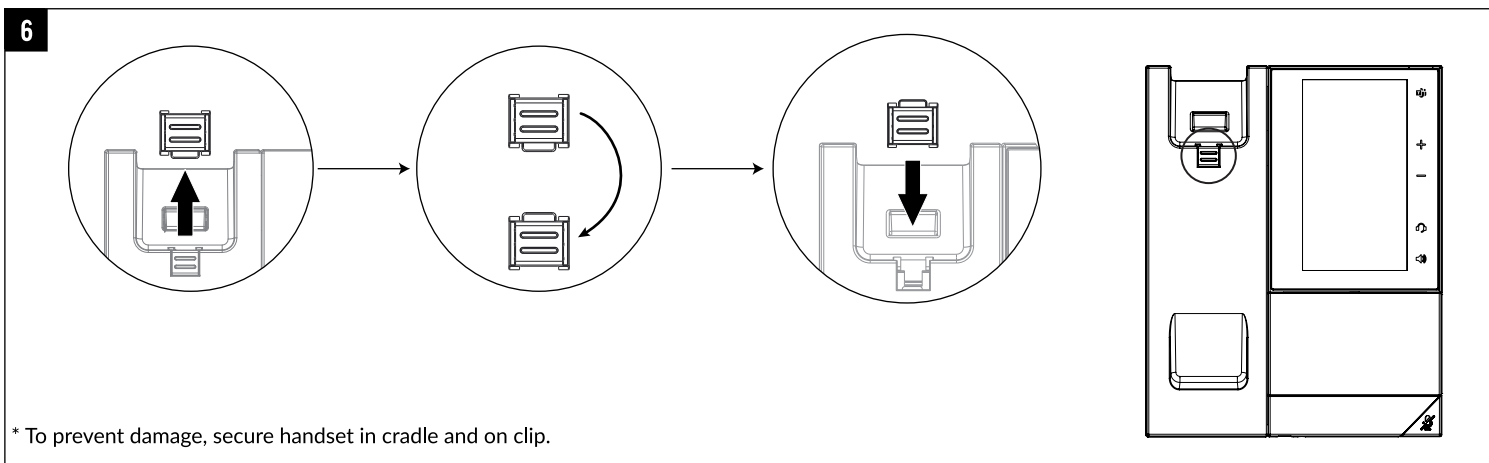

* To prevent damage, secure handset in cradle and on clip.

FACE PLATE INSTRUCTIONS

Instructions de montage du téléphone sur plaque murale • Blendenmontage für Telefon • Instrucciones de placa de pared para teléfono • Instruções para a placa frontal do telefone • Istruzioni per il montaggio su piastra del telefono • 电话面板安装说明 • 電話面板安裝說明 • 전화기 면판 설치 방법 • 電話機のフェイスブ

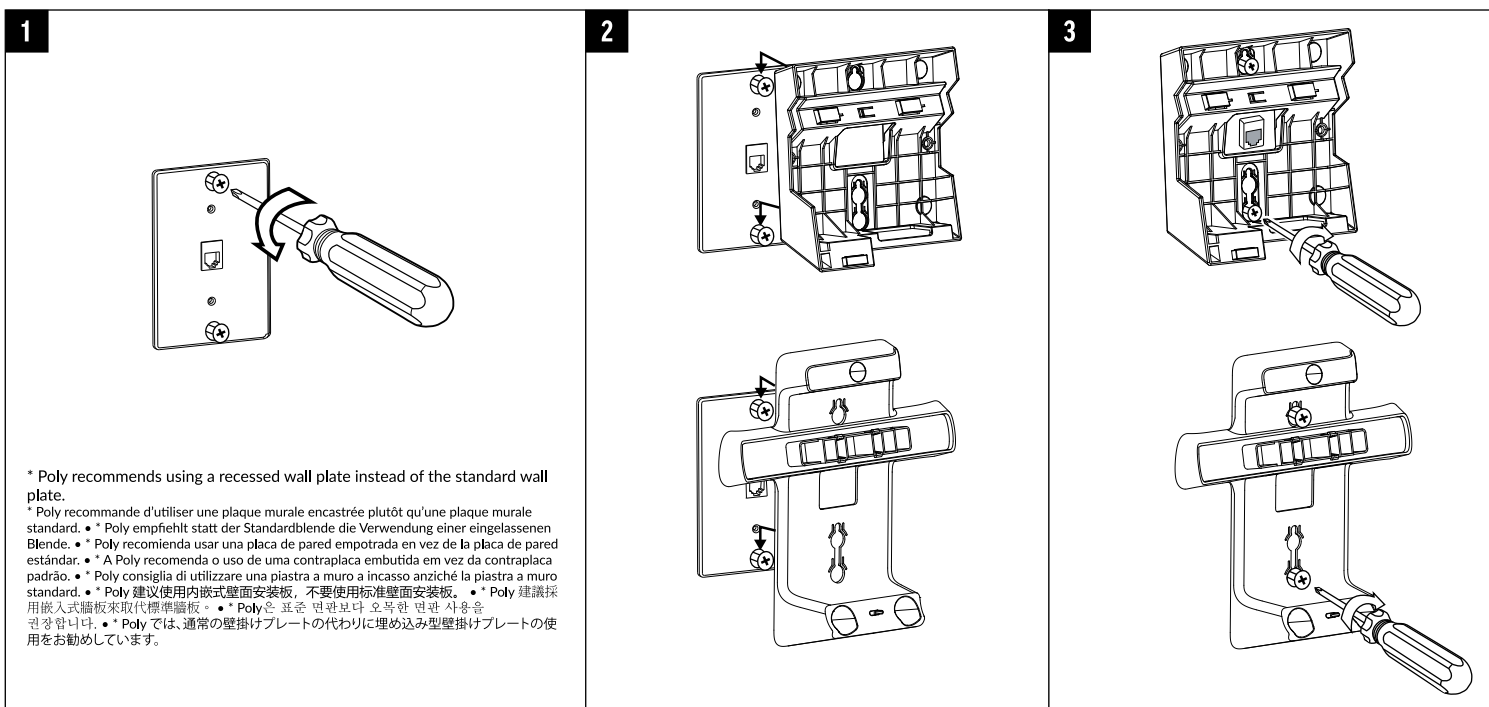

* Poly recommends using a recessed wall plate instead of the standard wall plate.
 * Poly recommande d'utiliser une plaque murale encastrée plutôt qu'une plaque murale standard. • * Poly empfiehlt statt der Standardblende die Verwendung einer eingelassenen Blende. • * Poly recomienda usar una placa de pared empotrada en vez de la placa de pared estándar. • * A Poly recomenda o uso de uma contraplaca embutida em vez da contraplaca padrão. • * Poly consiglia di utilizzare una piastra a muro a incasso anziché la piastra a muro standard. • * Poly 建议使用内嵌式壁面安装板, 不要使用标准壁面安装板。 • * Poly 建議採用嵌入式牆板來取代標準牆板。 • * Poly 은 표준 면판보다 오목한 면판 사용을 권장합니다. • * Poly では、通常の壁掛けプレートの代わりに埋め込み型壁掛けプレートの使用をお勧めしています。