



Cisco Nexus 9408 NX-OS Mode Switch Hardware Installation Guide

First Published: 2022-09-15

Americas Headquarters

Cisco Systems, Inc.
170 West Tasman Drive
San Jose, CA 95134-1706
USA
<http://www.cisco.com>
Tel: 408 526-4000
800 553-NETS (6387)
Fax: 408 527-0883

THE SPECIFICATIONS AND INFORMATION REGARDING THE PRODUCTS REFERENCED IN THIS DOCUMENTATION ARE SUBJECT TO CHANGE WITHOUT NOTICE. EXCEPT AS MAY OTHERWISE BE AGREED BY CISCO IN WRITING, ALL STATEMENTS, INFORMATION, AND RECOMMENDATIONS IN THIS DOCUMENTATION ARE PRESENTED WITHOUT WARRANTY OF ANY KIND, EXPRESS OR IMPLIED.

The Cisco End User License Agreement and any supplemental license terms govern your use of any Cisco software, including this product documentation, and are located at: <http://www.cisco.com/go/softwareterms>. Cisco product warranty information is available at <http://www.cisco.com/go/warranty>. US Federal Communications Commission Notices are found here <http://www.cisco.com/c/en/us/products/us-fcc-notice.html>.

IN NO EVENT SHALL CISCO OR ITS SUPPLIERS BE LIABLE FOR ANY INDIRECT, SPECIAL, CONSEQUENTIAL, OR INCIDENTAL DAMAGES, INCLUDING, WITHOUT LIMITATION, LOST PROFITS OR LOSS OR DAMAGE TO DATA ARISING OUT OF THE USE OR INABILITY TO USE THIS MANUAL, EVEN IF CISCO OR ITS SUPPLIERS HAVE BEEN ADVISED OF THE POSSIBILITY OF SUCH DAMAGES.

Any products and features described herein as in development or available at a future date remain in varying stages of development and will be offered on a when-and if-available basis. Any such product or feature roadmaps are subject to change at the sole discretion of Cisco and Cisco will have no liability for delay in the delivery or failure to deliver any products or feature roadmap items that may be set forth in this document.

Any Internet Protocol (IP) addresses and phone numbers used in this document are not intended to be actual addresses and phone numbers. Any examples, command display output, network topology diagrams, and other figures included in the document are shown for illustrative purposes only. Any use of actual IP addresses or phone numbers in illustrative content is unintentional and coincidental.

The documentation set for this product strives to use bias-free language. For the purposes of this documentation set, bias-free is defined as language that does not imply discrimination based on age, disability, gender, racial identity, ethnic identity, sexual orientation, socioeconomic status, and intersectionality. Exceptions may be present in the documentation due to language that is hardcoded in the user interfaces of the product software, language used based on RFP documentation, or language that is used by a referenced third-party product.

Cisco and the Cisco logo are trademarks or registered trademarks of Cisco and/or its affiliates in the U.S. and other countries. To view a list of Cisco trademarks, go to this URL: [www.cisco.com go trademarks](http://www.cisco.com/go/trademarks). Third-party trademarks mentioned are the property of their respective owners. The use of the word partner does not imply a partnership relationship between Cisco and any other company. (1721R)

© 2022 Cisco Systems, Inc. All rights reserved.



CONTENTS

CHAPTER 1

Overview 1

Overview of the Cisco Nexus 9408 Switch 1

CHAPTER 2

Preparing the Site 5

Temperature Requirement 5

Humidity Requirement 5

Altitude Requirements 5

Dust and Contaminants 6

Minimizing Electromagnetic and Radio Frequency Interference 6

Shock and Vibration Requirements 7

Grounding Requirements 7

Rack and Cabinet Requirements 7

Clearance Requirements 8

CHAPTER 3

Installing the Chassis 11

Safety 11

Preparing to Install the Chassis 14

Unpacking and Inspecting the Chassis 16

Installing the Chassis in a Four-Post Rack 17

Grounding the Chassis 21

Starting the Switch 23

CHAPTER 4

Connecting the Switch to the Network 25

Preparing for Network Connections 25

Connecting to a Console 25

Connecting the Management Interface 26

Connecting Interface Ports to Other Devices	27
Installing SFP+ and SFP Transceivers	27
Installing QSFP+ Transceivers	28
Installing SFP+ and SFP Optical Cables	29
Maintaining Transceivers and Optical Cables	29
Creating the Initial Switch Configuration	30

CHAPTER 5**Replacing Modules 33**

Replacing a 4 (RU) Fan Module	33
Replacing an AC Power Supply	34
Replacing a Supervisor Module	35
Installing or Replacing a Line-Card Expansion Module (LEM)	38
Replacing a Switch Card	40
Fiber Optic Removal Using the Optics Extraction Tool	43

CHAPTER 6**Managing the Switch 45**

Displaying Information About the Installed Hardware Modules	45
Displaying the Hardware Inventory for the Switch	48
Displaying the Modules for the Switch	49
Displaying the Serial PROM (SPROM) for the Switch	50
Displaying Environmental Information for the Switch	51
Displaying Environment Temperature for the Switch	52

APPENDIX A**Rack Specifications 55**

General Requirements and Guidelines for Cabinets and Racks	55
About Requirements for Perforated Cabinets	56
About Requirements for Open Racks	56

APPENDIX B**System Specifications 57**

Environmental Specifications	57
Switch Dimensions	57
Switch and Module Weights	58
2000-W AC Power Supply Specifications	58
AC Power Cable Specifications	58

APPENDIX C	LEDs	61
	CPU Card LEDs	61
	LEM LEDs	62
	Fan LEDs	63
	Power Supply LEDs	64

APPENDIX D	Spare Parts Table	65
	Spares Support Table	65



CHAPTER 1

Overview

- [Overview of the Cisco Nexus 9408 Switch, on page 1](#)

Overview of the Cisco Nexus 9408 Switch

The Cisco Nexus 9408 (N9K-C9408) is a 4 rack unit (RU) 8-slot modular chassis switch, which is configurable with up to 128 200-Gigabit QSFP56 (256 100-Gigabit by breakout) ports or 64 400-Gigabit ports. This switch supports port-side intake airflow. The switch requires four AC power supplies for operation, and offers 2+2 power grid redundancy.

This switch includes the following high power optics and MACsec:

- The N9K-X9400-16W LEM offers full MACsec (128 ports) for a full load chassis with no limitation for 200G optics.
- The N9K-X9400-8D LEM offers full MACsec (64 ports) for a full load chassis but with a limit of 400G high power optics within 32pcs among 8 slots (maximum of 32 ports of 20-W optics irrespective of MACsec), and the high power optics can go in any of the 400G ports.

The following figure shows the fan-side chassis features that you use when installing the chassis or replacing its modules.

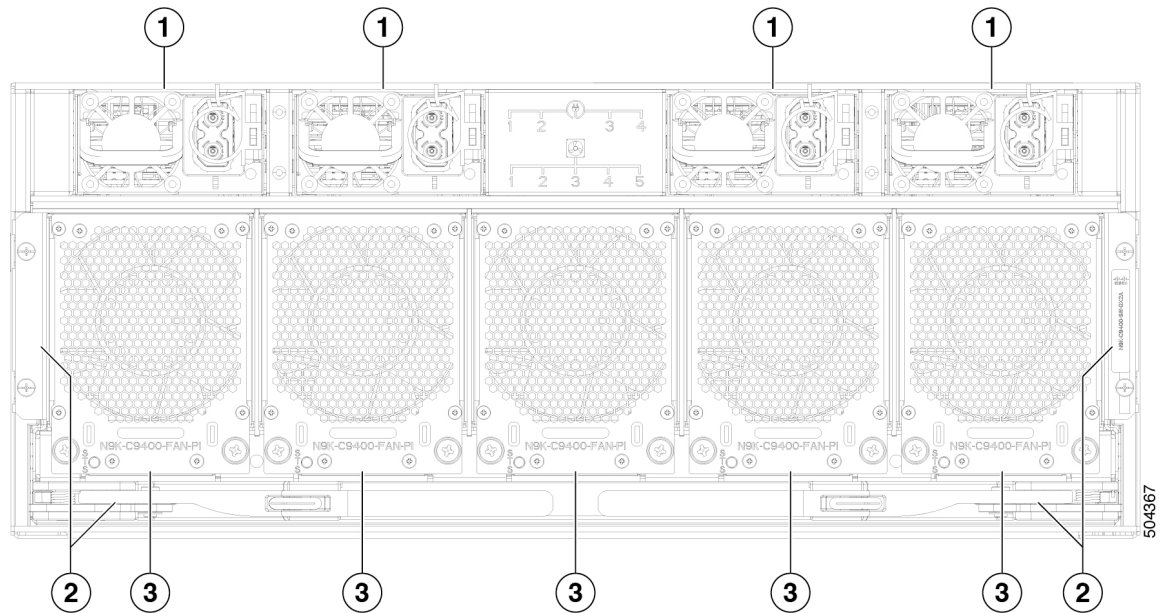

1	Power supply modules (4)	2	Switch card
3	Fan modules (5)		

The following figure shows the port-side chassis features that you use when installing the chassis or replacing its modules.

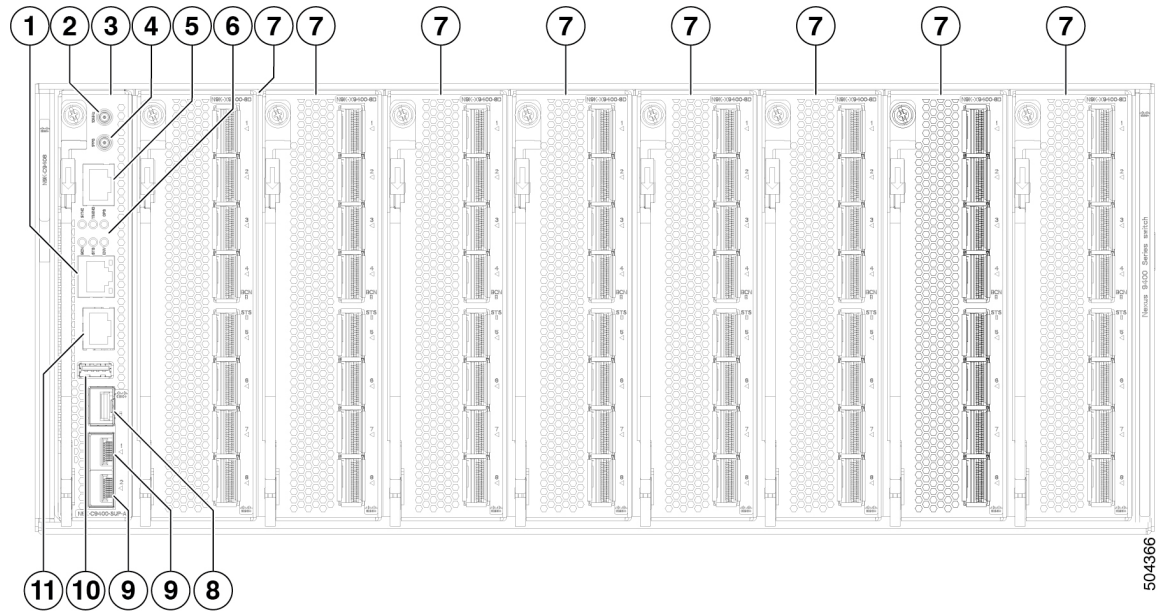

1	Management port (RJ45)	2	GPS 10 MHz
3	Supervisor module (N9K-C9408-SUP-A)	4	GPS 1PPS
5	ToD (RF-45)	6	SYNC, TIMING, GPS, BCN, STS, and ENV, LEDs

7	Cisco Nexus line-card expansion module (LEM) (up to 8) N9K-X9400-8D shown, N9K-X9400-16W also available.	8	Management port (SFP)
9	Fixed 1/10G SFP+ ports (Eth10/1 and Eth10/2)	10	USB 3.0 port (1) ¹
11	Console port (RS-232)		

¹ Careful when using the USB port. This component is sensitive to movement and if bumped, may cause file corruption.

The following figure shows the side chassis features that you use when installing the chassis.

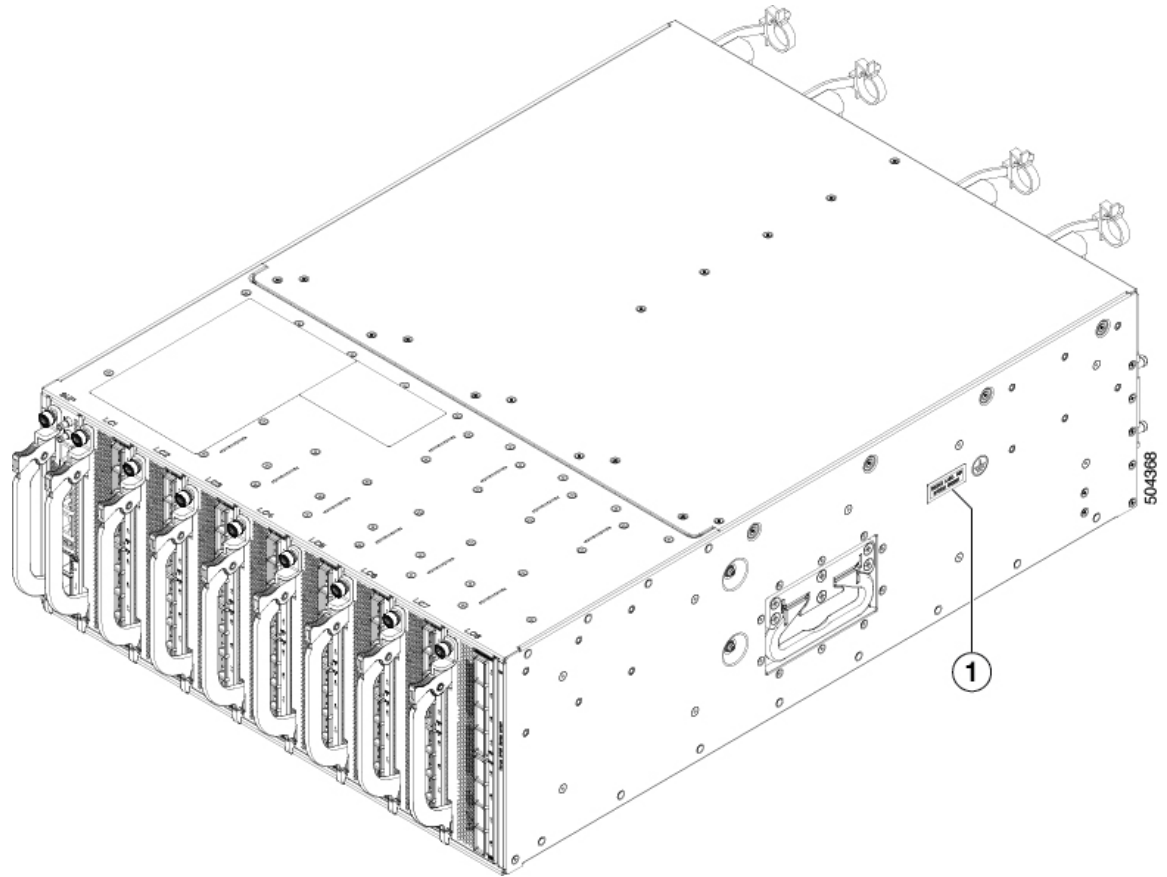

1	Grounding pad		
---	---------------	--	--



CHAPTER 2

Preparing the Site

- [Temperature Requirement, on page 5](#)
- [Humidity Requirement, on page 5](#)
- [Altitude Requirements, on page 5](#)
- [Dust and Contaminants, on page 6](#)
- [Minimizing Electromagnetic and Radio Frequency Interference, on page 6](#)
- [Shock and Vibration Requirements, on page 7](#)
- [Grounding Requirements, on page 7](#)
- [Rack and Cabinet Requirements, on page 7](#)
- [Clearance Requirements, on page 8](#)

Temperature Requirement

This switch is rated to operate at 32 to 104°F (0 to 40°C). It can be stored at -40 to 158°F (-40 to 70°C).

Humidity Requirement

High humidity can cause moisture to enter the switch. Moisture can cause corrosion of internal components and degradation of properties such as electrical resistance, thermal conductivity, physical strength, and size. The switch is rated to withstand from 5- to 95-percent (nonoperating) and 5- to 90-percent (operating) relative humidity.

Buildings cooled with air conditioning during warm months and warmed during cold months usually maintain an acceptable level of humidity. However, if the site is unusually humid, use a dehumidifier to maintain the required humidity level.

Altitude Requirements

High-altitude (low-pressure) conditions outside of 0 to 5,000 feet (0 to 1524 m) can reduce the cooling efficiency and cause electrical problems.

Dust and Contaminants

To prevent contaminant buildup and increased internal chassis temperatures, make sure that the operating environment is as clean as possible and free of dust and other contaminants. Do not permit smoking, food, or drinks near the switch.

Minimizing Electromagnetic and Radio Frequency Interference

Electromagnetic interference (EMI) and radio frequency interference (RFI) from the switch can adversely affect other devices, such as radio and television (TV) receivers. Radio frequencies that emanate from the switch can also interfere with cordless and low-power telephones. Conversely, RFI from high-power telephones can cause spurious characters to appear on the switch monitor.

RFI is defined as any EMI with a frequency above 10 kHz. This type of interference can travel from the switch to other devices through the power cable and power source or through the air as transmitted radio waves. The Federal Communications Commission (FCC) publishes specific regulations to limit the amount of EMI and RFI that are emitted by computing equipment. Each switch meets these FCC regulations.

To reduce the possibility of EMI and RFI, follow these guidelines:

- Cover all open expansion slots with a blank filler plate.
- Always use shielded cables with metal connector shells for attaching peripherals to the switch.

When wires are run for any significant distance in an electromagnetic field, interference can occur to the signals on the wires with the following implications:

- Bad wiring can result in radio interference emanating from the plant wiring.
- Strong EMI, especially when it is caused by lightning or radio transmitters, can destroy the signal drivers and receivers in the chassis and even create an electrical hazard by conducting power surges through lines into equipment.



Note To predict and prevent strong EMI, you need to consult experts in radio frequency interference (RFI).

The wiring is unlikely to emit radio interference if you use a twisted-pair cable with a good distribution of grounding conductors. If you exceed the recommended distances, use a high-quality twisted-pair cable with one ground conductor for each data signal when applicable.



Caution If the wires exceed the recommended distances, or if wires pass between buildings, give special consideration to the effect of a lightning strike in your vicinity. The electromagnetic pulse that is caused by lightning or other high-energy phenomena can easily couple enough energy into unshielded conductors to destroy electronic switches. You will want to consult experts in electrical surge suppression and shielding if you had similar problems in the past.

Shock and Vibration Requirements

The switch has been shock- and vibration-tested for operating ranges, handling, and earthquake standards.

Grounding Requirements

The switch is sensitive to variations in voltage that is supplied by the power sources. Overvoltage, undervoltage, and transients (or spikes) can erase data from memory or cause components to fail. To protect against these types of problems, ensure that there is an earth-ground connection for the switch. You can connect the grounding pad on the switch either directly to the earth-ground connection or to a fully bonded and grounded rack.

When you properly install the chassis in a grounded rack, the switch is grounded because it has a metal-to-metal connection to the rack. Alternatively, you can ground the chassis by using a customer-supplied grounding cable that meets your local and national installation requirements. For U.S. installations, we recommend 6-AWG wire. Connect your grounding cable to the chassis with a grounding lug (provided in the switch accessory kit) and to the facility ground.



Note You automatically ground AC power supplies when you connect them to AC power sources. For DC power supplies, you must connect a grounding wire when wiring the power supply to the DC power source.



Note An electrical conducting path shall exist between the product chassis and the metal surface of the enclosure or rack in which it is mounted or to a grounding conductor. Electrical continuity shall be provided by using thread-forming type mounting screws that remove any paint or non-conductive coatings and establish a metal-to-metal contact. Any paint or other non-conductive coatings shall be removed on the surfaces between the mounting hardware and the enclosure or rack. The surfaces shall be cleaned and an antioxidant applied before installation.

Rack and Cabinet Requirements

You can install the following types of racks or cabinets for your switch:

- Standard perforated cabinets
- Solid-walled cabinets with a roof fan tray (bottom-to-top cooling)
- Standard open four-post Telco racks

To install the switch in a cabinet that is located in a hot-aisle and cold-aisle environment, fit the cabinet with baffles to prevent exhaust air from recirculating into the chassis air intake.

Work with your cabinet vendors to determine which of their cabinets meet the following requirements or see the Cisco Technical Assistance Center (TAC) for recommendations:

- Use a standard 19-inch (48.3-cm), four-post Electronic Industries Alliance (EIA) cabinet or rack with mounting rails that conform to English universal hole spacing per section 1 of the ANSI/EIA-310-D-1992 standard.
- The height of the rack or cabinet must accommodate the 7.1-RU (12.4 inches or 31.6 cm) height of the switch and its bottom support bracket.
- The depth of a four-post rack must be 24 to 32 inches (61.0 to 81.3 cm) between the front and rear mounting rails (for proper mounting of the bottom-support brackets or other mounting hardware).
- Required clearances between the chassis and the edges of its rack or the interior of its cabinet are as follows:
 - 4.5 inches (11.4 cm) between the front of the chassis and the front of the rack or interior of the cabinet (required for cabling and module handles).
 - 3.0 inches (7.6 cm) between the rear of the chassis and the interior of the cabinet (required for airflow in the cabinet if used).
 - No clearance is required between the chassis and the sides of the rack or cabinet (no side airflow).

Also, you must consider the following site requirements for the rack:

Also, you must have power receptacles that are located within reach of the power cords that are used with the switch.



Warning **Statement 1048**—Rack Stabilization

The rack stabilizing mechanism must be in place, or the rack must be bolted to the floor before installation or servicing. Failure to stabilize the rack can cause bodily injury.

Clearance Requirements

Provide the chassis with adequate clearance between the chassis and any other rack, device, or structure so that you can properly install the chassis. Provide the chassis with adequate clearance to route cables, provide airflow, and maintain the switch. For the clearances required for an installation of this chassis, see the following figure.

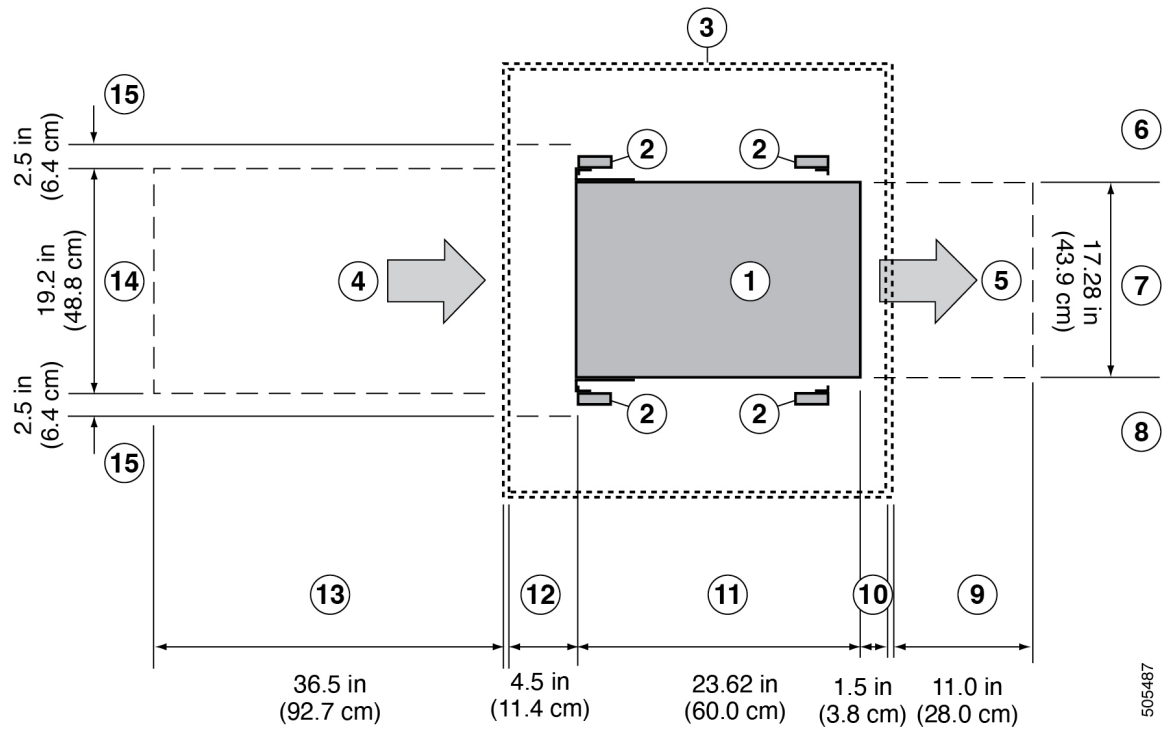

1	Chassis	9	Rear service clearance required to replace fan trays and fabric modules.
2	Vertical rack-mount posts and rails	10	Minimum clearance required for module handles (up to 6 inches [15.24 cm] recommended for optimal airflow) when using cabinet doors
3	Cabinet (optional)	11	Chassis depth
4	Air intake from the cold aisle for all modules and power supplies	12	Recommended clearance for cable management and ejector handles on line cards (6 inches [15.24 cm] recommended for optimal airflow) when using cabinet doors
5	Air exhaust to the hot aisle for all modules and power supplies	13	Clearance required for installing the chassis and replacing line cards
6	No left-side clearance required (no airflow on the left side).	14	Width of the chassis plus vertical mounting brackets on each side
7	Chassis width	15	Side clearance, that is required for older line card handle rotation (not required for the current line cards which have handles that rotate differently).
8	No right-side clearance required (no airflow on the right side).		



CHAPTER 3

Installing the Chassis

- [Safety, on page 11](#)
- [Preparing to Install the Chassis, on page 14](#)
- [Unpacking and Inspecting the Chassis, on page 16](#)
- [Installing the Chassis in a Four-Post Rack, on page 17](#)
- [Grounding the Chassis, on page 21](#)
- [Starting the Switch, on page 23](#)

Safety

Before you install, operate, or service the switch, see the *Regulatory, Compliance, and Safety Information for the Cisco Nexus 3000 and 9000 Series* for important Safety Information.



Warning **Statement 1071**—Warning Definition

IMPORTANT SAFETY INSTRUCTIONS

Before you work on any equipment, be aware of the hazards involved with electrical circuitry and be familiar with standard practices for preventing accidents. Read the installation instructions before using, installing, or connecting the system to the power source. Use the statement number provided at the end of each warning statement to locate its translation in the translated safety warnings for this device.

SAVE THESE INSTRUCTIONS



Warning **Statement 1089**—Instructed and Skilled Person Definitions

An instructed person is someone who has been instructed and trained by a skilled person and takes the necessary precautions when working with equipment.

A skilled person or qualified personnel is someone who has training or experience in the equipment technology and understands potential hazards when working with equipment.

There are no serviceable parts inside. To avoid risk of electric shock, do not open.

**Warning Statement 1074**—Comply with Local and National Electrical Codes

To reduce risk of electric shock or fire, installation of the equipment must comply with local and national electrical codes.

**Note Statement 407**—Japanese Safety Instruction

You are strongly advised to read the safety instruction before using the product.

<https://www.cisco.com/web/JP/techdoc/pldoc/pldoc.html>

When installing the product, use the provided or designated connection cables/power cables/AC adapters.

〈製品仕様における安全上の注意〉
www.cisco.com/web/JP/techdoc/index.html

接続ケーブル、電源コードセット、ACアダプタ、バッテリーなどの部品は、必ず添付品または指定品をご使用ください。添付品・指定品以外をご使用になると故障や動作不良、火災の原因となります。また、電源コードセットは弊社が指定する製品以外の電気機器には使用できないためご注意ください。

**Warning Statement 1017**—Restricted Area

This unit is intended for installation in restricted access areas. Only skilled, instructed, or qualified personnel can access a restricted access area.

**Warning Statement 1030**—Equipment Installation

Only trained and qualified personnel should be allowed to install, replace, or service this equipment.

**Warning Statement 1091**—Installation by an Instructed Person

Only an instructed person or skilled person should be allowed to install, replace, or service this equipment. See statement 1089 for the definition of an instructed or skilled person.

There are no serviceable parts inside. To avoid risk of electric shock, do not open.

**Warning Statement 1005**—Circuit Breaker

This product relies on the building's installation for short-circuit (overcurrent) protection. To reduce risk of electric shock or fire, ensure that the protective device is rated not greater than: 20A for AC, 60A for DC



Warning **Statement 1028—More Than One Power Supply**

This unit might have more than one power supply connection. To reduce risk of electric shock, remove all connections to de-energize the unit.

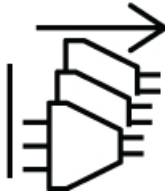

Warning **Statement 1003—Power Disconnection**

To reduce risk of electric shock or personal injury, disconnect DC power before removing or replacing components or performing upgrades.



Warning **Statement 1046—Installing or Replacing the Unit**

To reduce risk of electric shock, when installing or replacing the unit, the ground connection must always be made first and disconnected last.

If your unit has modules, secure them with the provided screws.



Warning **Statement 1022—Disconnect Device**

To reduce the risk of electric shock and fire, a readily accessible disconnect device must be incorporated in the fixed wiring.



Warning **Statement 1033—Safety Extra-Low Voltage (SELV)—IEC 60950/ES1–IEC 62368 DC Power Supply**

To reduce the risk of electric shock, connect the unit to a DC power source that complies with the SELV requirements in IEC 60950-based safety standards or ES1 and PS1 requirements in IEC 62368-based safety standards or to a Class 2 power supply.



Warning **Statement 1024—Ground Conductor**

This equipment must be grounded. To reduce the risk of electric shock, never defeat the ground conductor or operate the equipment in the absence of a suitably installed ground conductor. Contact the appropriate electrical inspection authority or an electrician if you are uncertain that suitable grounding is available.



Warning Statement 1032—Lifting the Chassis

To prevent personal injury or damage to the chassis, never attempt to lift or tilt the chassis using the handles on modules, such as power supplies, fans, or cards. These types of handles are not designed to support the weight of the unit.



Warning Statement 1006—Chassis Warning for Rack-Mounting and Servicing

To prevent bodily injury when mounting or servicing this unit in a rack, you must take special precautions to ensure that the system remains stable. The following guidelines are provided to ensure your safety:

- This unit should be mounted at the bottom of the rack if it is the only unit in the rack.
 - When mounting this unit in a partially filled rack, load the rack from the bottom to the top with the heaviest component at the bottom of the rack.
 - If the rack is provided with stabilizing devices, install the stabilizers before mounting or servicing the unit in the rack.
-



Warning Statement 1047—Overheating Prevention

To reduce the risk of fire or bodily injury, do not operate the unit in an area that exceeds the maximum recommended ambient temperature of: 40°C



Caution To prevent loss of input power, ensure the total maximum loads on the circuits supplying power to the switch are within the current ratings for the wiring and breakers.



Note For AC input application, please refer to the statement below:



Warning Statement 1005—Circuit Breaker

This product relies on the building's installation for short-circuit (overcurrent) protection. Ensure that the protective devices is rated not greater than 20A (North America), 16A (Europe), and 13A (UK).

Preparing to Install the Chassis

Before you can install the switch, you must verify the following:

- The installation site meets the following requirements as stated in Chapter 2:

- Environmental requirements for temperature, humidity, altitude, and air particulates.
- Cabinet or rack is installed and meets the requirements for the switch.



Note Jumper power cords are available for use in a cabinet.

- The rack is positioned so that you can install the switch with its cold air intakes positioned in a cold aisle.

If the fan and power supply modules are burgundy or red colored, you must install the chassis with its port side in a cold aisle. If the modules are blue colored, you must be able install the chassis with the fan modules in a cold aisle.

- Earth ground connection is close to the switch. You must be able to easily connect the switch directly to an earth ground or indirectly through a grounded rack.



Caution High leakage current. Earth connection essential before connecting to power supply.

- Site power meets the switch requirements. If you are using n+n redundancy, you must have two power sources within reach of the switch when it is installed in the cabinet or rack.
- If available, you can use an uninterruptible power supply (UPS) to protect against power failures.



Caution Avoid UPS types that use ferroresonant technology. These UPS types can become unstable with systems such as the Cisco Nexus switches. These switches can have substantial current draw fluctuations because of fluctuating data traffic patterns.

Ensure that circuits are sized according to local and national codes. For North America, the power supply requires a 15-A or 20-A circuit.



Caution To prevent loss of input power, ensure the total maximum loads on the circuits supplying power to the switch are within the current ratings for the wiring and breakers.

- There is adequate clearance around the rack to install the switch and to allow for unimpeded airflow.
- You have the following equipment in addition to the switch and the kits shipped with the switch:
 - Eight customer-supplied 12-24 or 10-32 screws (required for attaching slider rails and mounting bracket to the mounting rails)
 - Number 1 and number 2 Phillips screwdrivers with torque capability
 - 3/16-inch flat-blade screwdriver
 - Tape measure and level

- ESD wrist strap or other grounding device (wrist strap can be found in the accessory kit)
- Antistatic surface large enough to place the switch
- Grounding cable (6 AWG recommended), sized according to local and national installation requirements; the required length depends on the proximity of the switch to proper grounding facilities
- Crimping tool large enough to accommodate the girth of the grounding lug
- Wire stripping tool

Unpacking and Inspecting the Chassis



Caution When handling switch components, such as fan or power supply modules, wear a grounded ESD strap and handle the modules by their carrier edges only. To ground the ESD strap, make sure that it is attached to an earth ground, a grounded chassis, or a grounded rack.



Tip Keep the shipping container in case the chassis requires shipping in the future.



Note The switch is thoroughly inspected before shipment. If any damage occurred during transportation or any items are missing, contact your customer service representative immediately.

To inspect the switch, follow these steps:

-
- Step 1** Compare the shipment to the equipment list provided by your customer service representative and verify that you have received all items.
- Step 2** Check for damage and report any discrepancies or damage to your customer service representative. Have the following information ready:
- Invoice number of shipper (see the packing slip)
 - Model and serial number of the damaged unit
 - Description of damage
 - Effect of damage on the installation
 - Photos of the damaged shipping containers and damaged product
- Step 3** For dual direction airflow switches, check to be sure that all of the fan and power supply modules have the same airflow direction.
- Port-side intake airflow direction indicated with burgundy coloring

- Port-side exhaust airflow direction indicated with blue coloring

Installing the Chassis in a Four-Post Rack

This section describes the installation of the Cisco Nexus 9408 platform switch, into a four-post rack, using the N9K-C9400-RMK rack-mount kit.

Before moving or lifting the chassis, follow these guidelines:

- Ensure that there is adequate space around the switch for servicing and airflow.
- Never attempt to lift an object that is too heavy for you to lift by yourself.
- Ensure that you have solid footing. Distribute the weight of the switch is evenly between your feet.
- Lift the switch slowly, keeping your back straight. Lift with your legs, not with your back. Bend at the knees, not at the waist.



Warning **Statement 1091**—Installation by an Instructed Person

Only an instructed person or skilled person should be allowed to install, replace, or service this equipment. See statement 1089 for the definition of an instructed or skilled person.

There are no serviceable parts inside. To avoid risk of electric shock, do not open.



Warning **Statement 1032**—Lifting the Chassis

To prevent personal injury or damage to the chassis, never attempt to lift or tilt the chassis using the handles on modules, such as power supplies, fans, or cards. These types of handles are not designed to support the weight of the unit.



Warning **Statement 1006**—Chassis Warning for Rack-Mounting and Servicing

To prevent bodily injury when mounting or servicing this unit in a rack, you must take special precautions to ensure that the system remains stable. The following guidelines are provided to ensure your safety:

- This unit should be mounted at the bottom of the rack if it is the only unit in the rack.
 - When mounting this unit in a partially filled rack, load the rack from the bottom to the top with the heaviest component at the bottom of the rack.
 - If the rack is provided with stabilizing devices, install the stabilizers before mounting or servicing the unit in the rack.
-

Step 1 Attach two front-mount brackets to the sides of the chassis as follows:

- a) Align the two holes in one side of a front-mount bracket to the holes on the left or right side of the chassis as shown in the following figure.

Figure 1: Aligning and Attaching Front-Mount Brackets to the Chassis

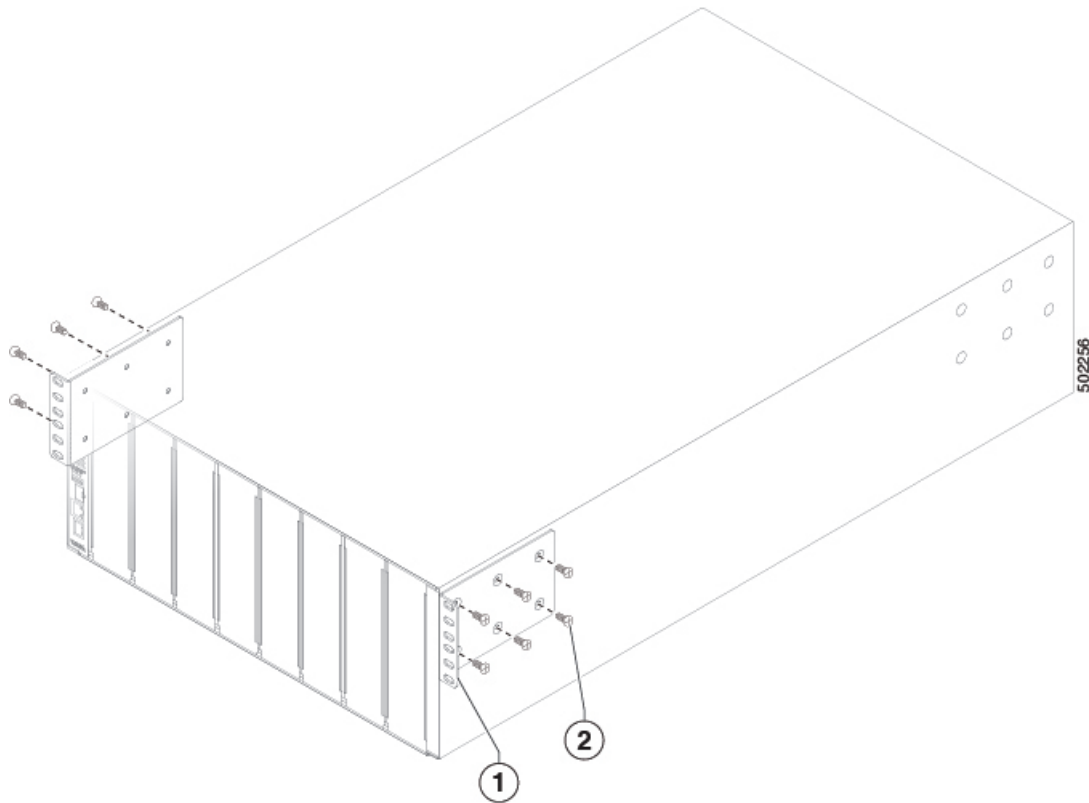

1	Front rack-mount bracket	2	M4 x 6-mm screws
---	--------------------------	---	------------------

- b) Use M4 x 6 mm screws to attach the bracket to the chassis and tighten each screw to 12 in-lb (1.36 N·m) of torque.
 c) Repeat Steps 1a and 1b to attach the other front-mount bracket to the other side of the chassis.

Step 2 Align the bottom-support rails so that they form a shelf for the chassis.

Note The bottom-support rails are not interchangeable. Use the one marked with [R] for the right, and with [L] for the left side of the rack.

Figure 2: Aligning the Bottom-Support Rails

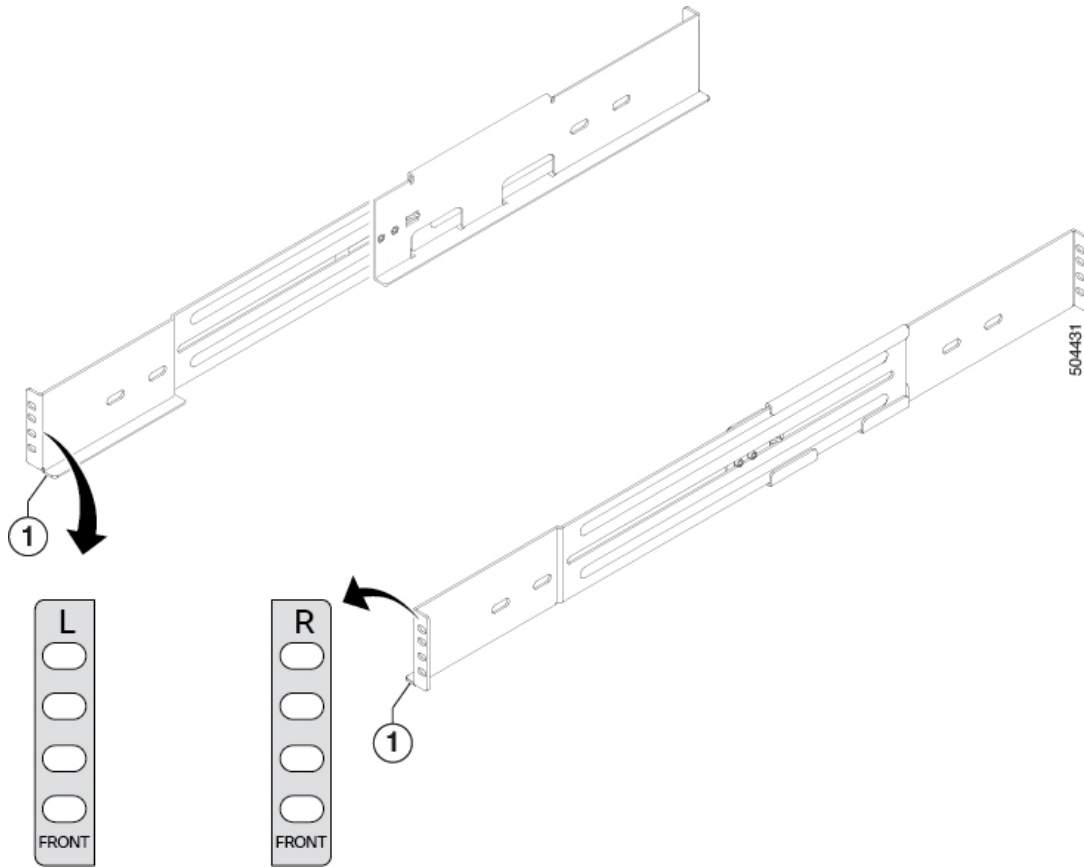

1	Bottom-support rail (2)		
---	-------------------------	--	--

Step 3

Attach the bottom-support rails on the rack as follows:

- a) Position an expanding set of bottom-support brackets on the rack with each end touching a vertical mounting rail on the front and rear of the rack as shown in the following figure.

Figure 3: Positioning the Bottom-Support Rails

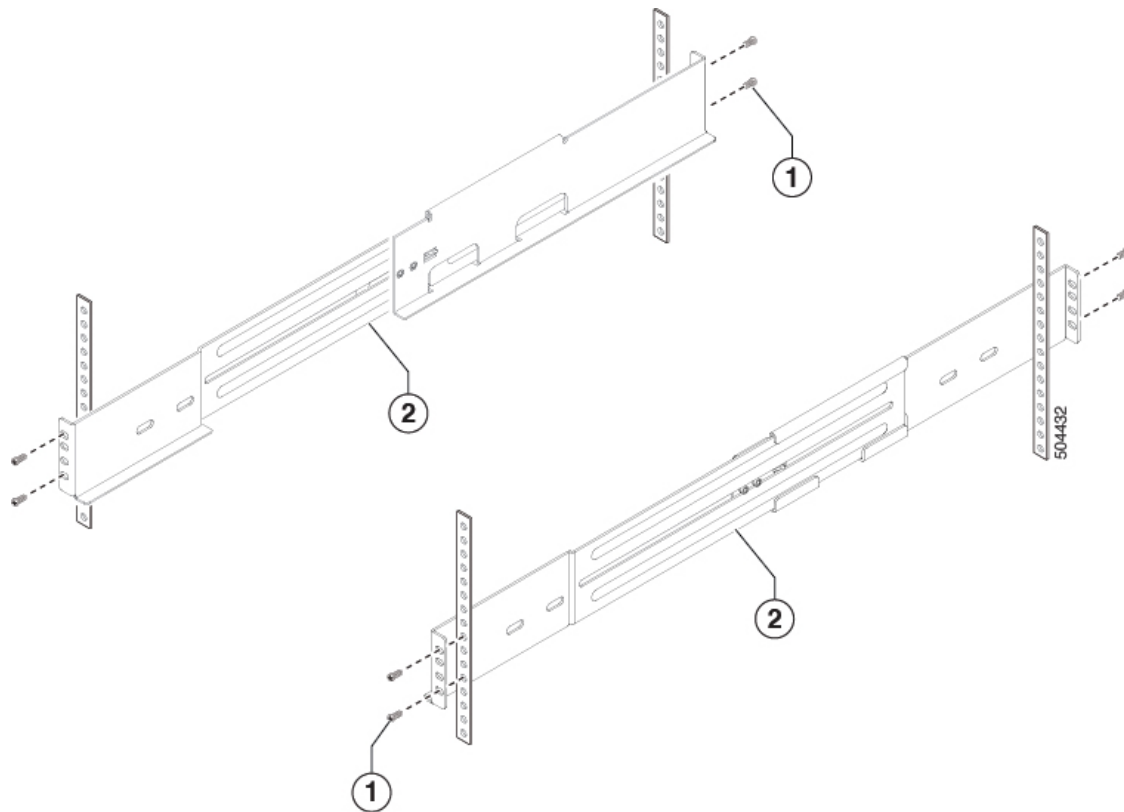

1	Screws holding the bottom-support bracket to the rack	2	The bottom-support brackets (2)
---	---	---	---------------------------------

- b) Holding the bottom-support rail level, attach the rail to the front and rear vertical mounting rails using four customer-supplied screws that are appropriate for the rack (use two screws for each vertical mounting rail), and tighten each screw to the appropriate torque setting for that screw.

Typically, you use one of the following types of screws and the associated torque settings when tightening them:

- M4 screws—Use 12 in-lb (1.36 N·m) of torque.
- M6 screws—Use 40 in-lb (4.5 N·m) of torque.
- 10-32 screws— Use 20 in-lb (2.26 N·m) of torque.

If the rack requires another type of screw, use the appropriate torque setting for that type of screw.

- c) Repeat Steps 3a and 3b to attach the other expanding bottom-support rail to the other side of the rack at the same level as the attached bottom-support rail.

Note Verify that the two sets of bottom-support rails are level with each other before going to the next step.

Step 4 Install the chassis in the rack as follows:

- a) Slide the power supply end of the chassis onto the installed bottom-support rails as shown in the following figure.

Note When sliding the chassis onto the bottom-support rails, proceed slowly and cautiously so that you don't damage the switch or support rails.

When you have fully pushed the chassis all the way onto the bottom-support rails, the chassis stops when the front-mount brackets touch the front vertical mounting rack.

Figure 4: Sliding the Chassis onto the Bottom-Support Rails

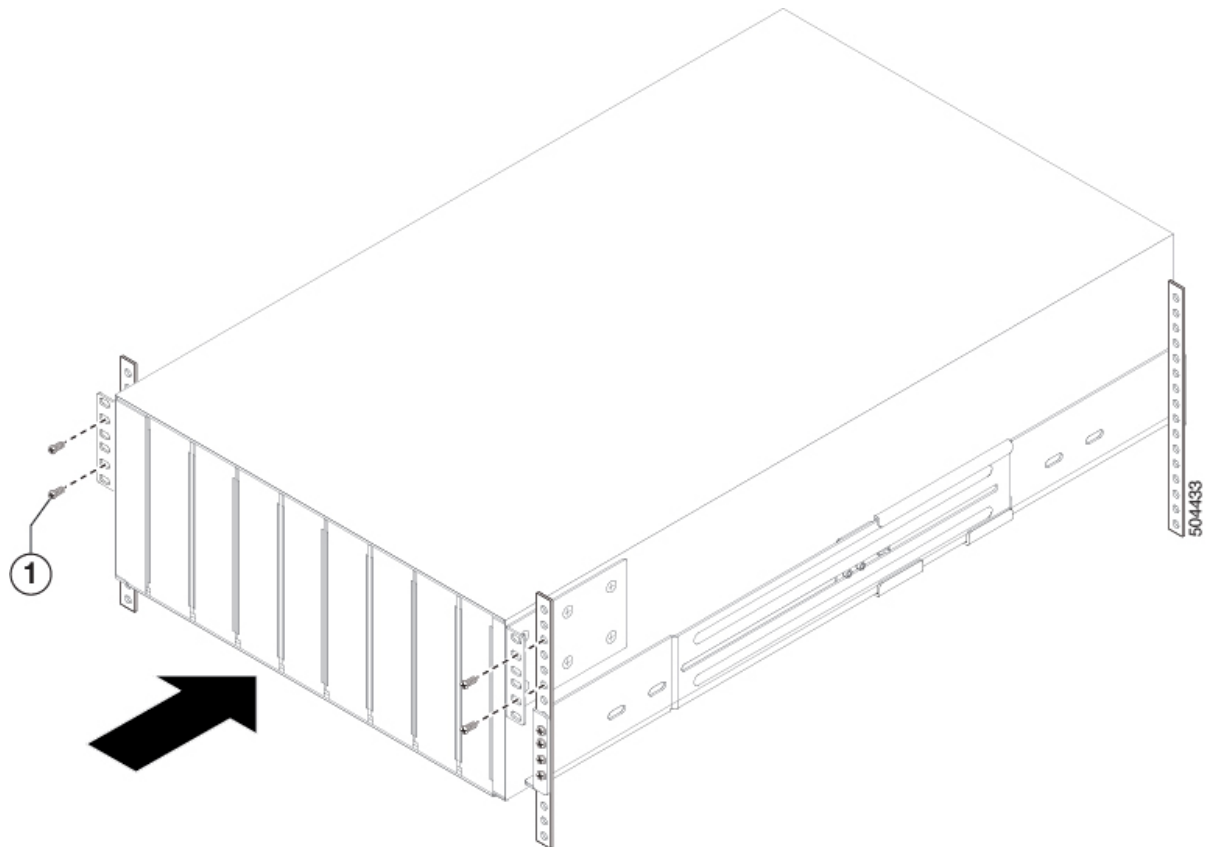

1	Rack-mount screw		
---	------------------	--	--

- b) Use screws that are appropriate for the rack to attach the front-mount brackets to the rack.

Typically, you use one of the following types of screws and the associated torque settings when tightening them:

- M4 screws—Use 12 in-lb (1.36 N·m) of torque.
- M6 screws—Use 40 in-lb (4.5 N·m) of torque.
- 10-32 screws— Use 20 in-lb (2.26 N·m) of torque.

If the rack requires another type of screw, use the appropriate torque setting for that type of screw.

Grounding the Chassis

The switch chassis is automatically grounded when you properly install the switch in a grounded rack with metal-to-metal connections between the switch and rack.

You can alternatively ground the chassis (this is required if the rack is not grounded) by attaching a customer-supplied grounding cable to the chassis grounding pad and the facility ground.



Note The location of the grounding pad on each switch can be found in the [Overview](#) section.



Note An electrical conducting path shall exist between the product chassis and the metal surface of the enclosure or rack in which it is mounted or to a grounding conductor. Electrical continuity shall be provided by using thread-forming type mounting screws that remove any paint or non-conductive coatings and establish a metal-to-metal contact. Any paint or other non-conductive coatings shall be removed on the surfaces between the mounting hardware and the enclosure or rack. The surfaces shall be cleaned and an antioxidant applied before installation.

The switch is grounded when you connect the chassis and the power supplies to the earth ground in the following ways:

- You connect the chassis (at its grounding pad) to the data center ground. If the rack is fully-bonded and grounded, you can ground the switch by connecting it to the rack.



Note The chassis ground connection is active even when the power supply modules have not been grounded or connected to the switch.



Warning Statement 1024—Ground Conductor

This equipment must be grounded. Never defeat the ground conductor or operate the equipment in the absence of a suitably installed ground conductor. Contact the appropriate electrical inspection authority or an electrician if you are uncertain that suitable grounding is available.



Warning Statement 1046—Installing or Replacing the Unit

When installing or replacing the unit, the ground connection must always be made first and disconnected last

Before you begin

Before you can ground the chassis, you must have a connection to the earth ground for the data center building. If you installed the switch chassis into a bonded rack (see the rack manufacturer's instructions for more information) that now has a connection to the data center earth ground, you can ground the chassis by installing it into the rack. Otherwise, you must connect the chassis grounding pad directly to the data center ground.

Step 1 Use a wire-stripping tool to remove approximately 0.75 inches (19 mm) of the covering from the end of the grounding wire.

- Step 2** Insert the stripped end of the grounding wire into the open end of the grounding lug, and use a crimping tool to crimp the lug to the wire (see Callout 2 in the following figure). Verify that the ground wire is securely attached to the grounding lug by attempting to pull the wire out of the crimped lug.

Figure 5: Grounding the Chassis

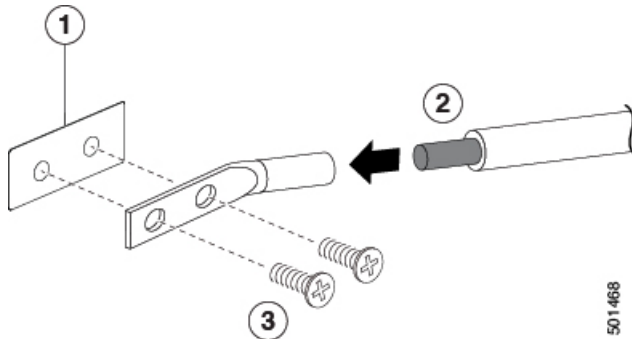

1	Chassis grounding pad	3	Two M4 screws used to secure the grounding lug to the chassis
2	Grounding cable, with 0.75 in. (19 mm) of insulation stripped from one end, inserted into the grounding lug and crimped in place		

- Step 3** Secure the grounding lug to the chassis grounding pad with two M4 screws (see Callouts 1 and 3 in the previous figure), and tighten the screws to 12 in lb (1.36 N·m) of torque.
- Step 4** Prepare the other end of the grounding wire and connect it to an appropriate grounding point in your site to ensure an adequate earth ground for the switch. If the rack is fully bonded and grounded, connect the grounding wire as explained in the documentation provided by the vendor for the rack.

Starting the Switch



Warning Statement 1005—Circuit Breaker

This product relies on the building's installation for short-circuit (overcurrent) protection. To reduce risk of electric shock or fire, ensure that the protective device is rated not greater than:

To power up the switch, follow these steps:

Before you begin

- Verify that the switch is fully installed and secured to a rack.
- Verify that the switch is adequately grounded to the facility earth ground or to a grounded rack.
- Verify that all of the fan and power supply modules are installed in the chassis. If the chassis has less than 4 power supplies, there must be a blank module (NXA-PS-BLANK) in the open power supply slot to maintain the designed airflow.

-
- Step 1** If the switch has AC power supplies, connect those power supplies to an AC power source as follows:
- Verify that the AC power source is turned off at the circuit breaker.
 - Plug the power cable into the power receptacle on the power supply.
 - Attach the other end of the power cable to the AC power source.
 - Turn on the power at the circuit breaker.
 - Verify that the power supply is functioning by making sure that the OK LED turns green and the FAULT LED is off.

Step 2 Listen for the fans; they should begin operating when the power cable is plugged in.

Step 3 After the switch boots, verify that the following LEDs are on:

- Power supply LED—lit and green
If not green, try removing the module part way from its slot and reinstalling it.
 - Fan LED—lit and green
If not green, try removing the module part way from its slot and reinstalling it.
 - System Status LED—lit and green (if this LED is orange or red, then one or more environmental monitors is reporting a problem.)
 - Link LEDs for the Ethernet connector—Off
-



CHAPTER 4

Connecting the Switch to the Network

- [Preparing for Network Connections, on page 25](#)
- [Connecting to a Console, on page 25](#)
- [Connecting the Management Interface, on page 26](#)
- [Connecting Interface Ports to Other Devices, on page 27](#)
- [Maintaining Transceivers and Optical Cables, on page 29](#)
- [Creating the Initial Switch Configuration, on page 30](#)

Preparing for Network Connections

When preparing your site for network connections to your switch, consider the following for each type of interface and gather all the required equipment before connecting the ports:

- Cabling required for each interface type
- Distance limitations for each signal type
- Additional interface equipment required

Connecting to a Console

You can connect the switch to a console to perform the following functions:

- Configuring the switch using the CLI
- Monitoring network statistics and errors
- Configuring SNMP agent parameters
- Downloading software updates



Note We recommend that you use this port to create a local management connection to set the IP address and other initial configuration settings before connecting the switch to the network for the first time.

The console port on the switch is an RS-232 port with an RJ-45 interface. This is an asynchronous (async) serial port; any device connected to this port must be capable of asynchronous transmission.



Caution The console port can be used to connect to a modem. If you do not connect it to a modem, connect it either before powering the switch on or after the switch has completed the boot process.

Before you begin

Before you connect the switch to a console, ensure that you have the following:

- Computer terminal that supports VT100 terminal emulation. The terminal emulation software (such as HyperTerminal or Procomm Plus) makes communication between the switch and a computer possible during setup and configuration.

Step 1 Configure the terminal emulator program to match each of the following default port characteristics:

- 9600 baud
- 8 data bits
- 1 stop bit
- No parity

Step 2 Connect the DB-9 connector on the other end of the cable to the computer serial port.

What to do next

You are ready to configure the switch.

Connecting the Management Interface

Before you begin

To prevent an IP address conflict, you must complete the initial configuration and establish an IP address for the switch.

Step 1 Connect the appropriate modular cable to on the switch.

Step 2 Connect the other end of the cable to the switch, hub, or router.

Connecting Interface Ports to Other Devices

After you perform the initial configuration for the switch and create a management connection, you are ready to connect the interface ports on the switch to other devices. Depending on the types of interface ports on the switch, you will need to use interface cables with QSFP+, SFP+, or SFP transceivers or RJ-45 connectors to connect the switch to other devices.

The transceivers used with many fiber-optic cables come separated from their cables. To prevent damage to the fiber-optic cables and their transceivers, we recommend that you keep these transceivers disconnected from their fiber-optic cables when installing the transceiver in the interface port. Before removing a transceiver for a fiber-optic cable, you must remove the cable from the transceiver.

To maximize the effectiveness and life of your transceivers and optical cables, do the following:

- Wear an ESD-preventative wrist strap that is connected to an earth ground whenever handling transceivers. The switch is typically grounded during installation and provides an ESD port to which you can connect your wrist strap.
- Do not remove and insert a transceiver more often than is necessary. Repeated removals and insertions can shorten its useful life.
- Keep the transceivers and fiber-optic cables clean and dust free to maintain high signal accuracy and to prevent damage to the connectors. Attenuation (loss of light) is increased by contamination and should be kept below 0.35 dB.
- Clean these parts before installation to prevent dust from scratching the fiber-optic cable ends.
- Clean the connectors regularly; the required frequency of cleaning depends upon the environment. In addition, clean connectors if they are exposed to dust or accidentally touched. Both wet and dry cleaning techniques can be effective; refer to your site's fiber-optic connection cleaning procedures.
- Do not touch the ends of connectors. Touching the ends can leave fingerprints and cause other contamination.
- Inspect routinely for dust and damage. If you suspect damage, clean and then inspect fiber ends under a microscope to determine if damage has occurred.



Warning **Statement 1051**—Laser Radiation

Invisible laser radiation may be emitted from disconnected fibers or connectors. Do not stare into beams or view directly with optical instruments

Installing SFP+ and SFP Transceivers



Note Excessively removing and installing an SFP or SFP+ transceiver can shorten its life. Unless it is absolutely necessary, do not remove and insert SFP or SFP+ transceivers. To prevent damage to an optical cable and transceiver, we recommend that you disconnect cables before installing or removing transceivers.



Note If you cannot install the cable into the transceiver, insert or leave the dust plug in the cable end of the transceiver.

- Step 1** Attach an ESD-preventive wrist strap and follow its instructions for use.
- Step 2** Remove the dust cover from the port cage.
- Step 3** Remove the dust cover from the port end of the transceiver.
- Step 4** Insert the transceiver into the port as follows:
- If the transceiver has a Mylar tab latch, position the transceiver with the tab on the bottom, and then gently insert the transceiver into the port until it clicks into place.
 - If the transceiver has a bale clasp latch, position the transceiver with the clasp on the bottom, close the clasp by pushing it up over the transceiver, and then gently insert the transceiver into the port until it clicks into place.
- Caution** If the transceiver does not install easily, ensure that it is correctly positioned and the tab or clasp are in the correct position before continuing.
-

Installing QSFP+ Transceivers

The QSFP+ transceiver module can have either a bail-clasp latch or a pull-tab latch.



Caution The QSFP+ transceiver module is a static-sensitive device. Always use an ESD wrist strap or similar individual grounding device when handling QSFP+ transceiver modules or coming into contact with system modules.

- Step 1** Attach an ESD wrist strap to yourself and a properly grounded point on the chassis or the rack. Follow its instructions for use.
- Step 2** Remove the QSFP+ transceiver module from its protective packaging.
- Step 3** Remove the dust cover from the port end of the transceiver.
- Step 4** Check the label on the QSFP+ transceiver module body to verify that you have the correct model for your network.
- Step 5** For optical QSFP+ transceivers, remove the optical bore dust plug and set it aside.
- Step 6** For transceivers equipped with a bail-clasp latch, do the following:
- a) Keep the bail-clasp aligned in a vertical position.
 - b) Align the QSFP+ transceiver in front of the module's transceiver socket opening and carefully slide the QSFP+ transceiver into the socket until the transceiver makes contact with the socket electrical connector.
- Step 7** For QSFP+ transceivers equipped with a pull-tab, do the following:
- a) Hold the transceiver so that the identifier label is on the top.
 - b) Align the QSFP+ transceiver in front of the module's transceiver socket opening and carefully slide the QSFP+ transceiver into the socket until the transceiver makes contact with the socket electrical connector.
-

Installing SFP+ and SFP Optical Cables



Note To prevent damage to an optical cable and transceiver, disconnect cables before installing or removing transceivers.

- Step 1** Attach an ESD-preventive wrist strap and follow its instructions for use.
- Step 2** Remove the dust cover from the connector on the cable.
- Step 3** Remove the dust cover from the cable end of the transceiver.
- Step 4** Align the cable connector with the transceiver and insert the connector into the transceiver until it clicks into place.
- Caution** If the cable does not install easily, ensure that it is correctly positioned before continuing.
- Note** If you cannot install the cable into the transceiver, insert or leave the dust plug in the cable end of the transceiver.

For instructions on verifying connectivity, see the appropriate Cisco Nexus Series configuration guide.

Maintaining Transceivers and Optical Cables

Transceivers and fiber-optic cables must be kept clean and dust free to maintain high signal accuracy and prevent damage to the connectors. Contamination increases attenuation (loss of light) and should be below 0.35 dB.

Consider the following maintenance guidelines:

- Transceivers are static sensitive. To prevent ESD damage, wear an ESD-preventative wrist strap that is connected to the grounded chassis.
- Do not remove and insert a transceiver more often than is necessary. Repeated removals and insertions can shorten its useful life.
- Keep all optical connections covered when not in use. Clean them before using to prevent dust from scratching the fiber-optic cable ends.
- Do not touch the ends of connectors. Touching the ends can leave fingerprints and cause other contamination.
- Clean the connectors regularly; the required frequency of cleaning depends upon the environment. In addition, clean connectors if they are exposed to dust or accidentally touched. Both wet and dry cleaning techniques can be effective; refer to the fiber-optic connection cleaning procedures for your site.
- Inspect routinely for dust and damage. If you suspect damage, clean and then inspect fiber ends under a microscope to determine if damage has occurred.

Creating the Initial Switch Configuration

You assign an IP address to the switch management interface so that you can then connect the switch to the network.

When you initially power up the switch, it boots up and asks you a series of questions to configure the switch. To connect the switch to the network, you can use the default choices for each configuration except the IP address, which you must provide. You can perform the other configurations later as described in the *Cisco Nexus 9000 Series NX-OS Fundamentals Configuration Guide*.



Note Know the unique name that is needed to identify the switch among the devices in the network.

Before you begin

- A console device must be connected with the switch.
- The switch must be connected to a power source.
- Determine the IP address and the netmask that is needed for the Management (Mgmt0) interface.

Step 1 Power up the switch by connecting each installed power supply to an AC circuit.

If you are using the input-source ($n+n$) power mode, connect half of the power supplies to one AC circuit. And connect the other half of the power supplies to another AC circuit.

The Input and Output LEDs on each power supply light up (green) when the power supply units are sending power to the switch, and the software asks you to specify a password to use with the switch.

Step 2 Enter a new password to use for this switch.

The software checks the security strength of your password and rejects your password if it is not considered to be a strong password. To increase the security strength of your password, make sure that it adheres to the following guidelines:

- At least eight characters
- Minimizes or avoids the use of consecutive characters (such as "abcd").
- Minimizes or avoids repeating characters (such as "aaabbb").
- Does not contain recognizable words from the dictionary.
- Does not contain proper names.
- Contains both uppercase and lowercase characters
- Contains numbers and letters

Note Clear text passwords cannot include the dollar sign (\$) special character.

Tip If a password is trivial (such as a short, easy-to-decipher password), the software will reject your password configuration. Be sure to configure a strong password as explained in this step. Passwords are case-sensitive.

If you enter a strong password, the software asks you to confirm the password.

Step 3 Enter the same password again.

If you enter the same password, the software accepts the password and begins asking a series of configuration questions.

Step 4 Until you are asked for an IP address, you can enter the default configuration for each question.

Repeat this step for each question until you are asked for the Mgmt0 IPv4 address.

Step 5 Enter the IP address for the management interface.

The software asks for the Mgmt0 IPv4 netmask.

Step 6 Enter a network mask for the management interface.

The software asks if you need to edit the configuration.

Step 7 Enter **no** not to edit the configuration.

The software asks if you need to save the configuration.

Step 8 Enter **yes** to save the configuration.

What to do next

You can now set up the management interface for each supervisor module on the switch.



CHAPTER 5

Replacing Modules

- [Replacing a 4 \(RU\) Fan Module, on page 33](#)
- [Replacing an AC Power Supply, on page 34](#)
- [Replacing a Supervisor Module, on page 35](#)
- [Installing or Replacing a Line-Card Expansion Module \(LEM\), on page 38](#)
- [Replacing a Switch Card, on page 40](#)
- [Fiber Optic Removal Using the Optics Extraction Tool , on page 43](#)

Replacing a 4 (RU) Fan Module

The fan module is designed to be removed and replaced while the system is operating without causing an electrical hazard or damage to the system if the replacement is performed within one minute.

If you do not have the appropriate replacement fan module, leave the original fan module in its slot to preserve the designed airflow for the switch until you have the replacement fan module. The module number can be found on the chassis.



Caution The fans might be turning when you remove the fan assembly from the chassis. Keep fingers, screwdrivers, and other objects away from the openings in the fan assembly's housing.

Before you begin

- Verify that you have an ESD wrist strap or other device to prevent ESD damage for components that you touch.
- Verify that you have an antistatic surface or bag for placing the fan module that you remove from the chassis.
- Verify that the replacement fan module has the correct direction of airflow (it has the same coloring as the other fan and power supply modules in the same chassis).

Step 1 Attach an ESD wrist strap or other ESD device to your body and an earth ground to prevent ESD damage.

You can attach the ESD device to any earth ground or grounded object, such as a grounded rack or ground connection on a chassis.

Step 2 Remove the fan module that you are replacing as follows:

- a) On the fan module that you are removing, unscrew the two captive screws on the front of the fan module until each screw is free of the chassis.
- b) Holding the handle, pull the module out of the chassis and set it on an antistatic surface or in an antistatic bag.

Caution Do not touch the electrical connectors on the back side of the module and prevent anything else from coming into contact with and damaging the connectors.

Step 3 Install the replacement fan module as follows:

- a) Hold the fan module with two hands. One hand holding its handle, and one hand supporting the weight of the fan module. Align the back of the fan module (the side with the electrical connectors) to the open fan slot in the chassis.
- b) Slide the fan module into the slot until it clicks in place.
- c) Tighten the fan module captive screws.
- d) Verify that the Status (STS) LED turns on and becomes green.

Replacing an AC Power Supply

You can replace an AC power supply during operations so long as there is another power supply installed and operating during the replacement. The switch requires two power supplies for operations, so you can hot swap the redundant power supply during operations. If there are only two power supplies installed in the chassis, you can replace one by installing the new power supply in the open power supply slot before removing the other power supply. The module number can be found on the chassis.



Note This switch supports port-side intake power supplies only (NXA-PAC-2KW-PI)

Before you begin

- Verify that you have an ESD wrist strap or other device to prevent ESD damage to the components that you touch.
- Verify that you have an antistatic surface or bag for placing the power supply module that you remove from the chassis.
- Verify that the replacement power supply module has the correct direction of airflow (it has the same coloring as the other fan and power supply modules in the same chassis). Otherwise the switch can overheat and shut down.

Step 1 Attach an ESD wrist strap or other ESD device to your body and an earth ground to prevent ESD damage.

You can attach the ESD device to any earth ground or grounded object, such as a grounded rack or ground connection on a chassis.

Step 2 Remove the power supply as follows:

- a) Pull the power cord out from the power receptacle on the power supply to be removed and verify that the OK LED turns off.

- b) Remove the power supply from the chassis by pushing and holding its thumb latch to the left and pulling the power supply part way out of the chassis.
- c) Place your other hand under the power supply to support it while you slide it out of the chassis.
Either place the power supply on an antistatic surface or pack it in its packing materials.
- d) If the power supply slot is to remain empty, install a blank power supply filler panel (part number NXA-PS-BLANK).

Step 3

Install the replacement power supply as follows:

- a) Holding the replacement power supply with one hand underneath the module and the other hand holding the handle, align the back end of the power supply (the end with the electrical connections) to the open power supply slot and slide the power supply all the way into the slot until it clicks into place.
- b) Test the installation by trying to pull the power supply out of the slot without using the release latch.

If the power supply does not move out of place, it is secured in the slot. If the power supply moves, press it all the way into the slot until it clicks in place.

Step 4

Connect the new power supply to an AC power source as follows:

- a) Attach the power cable to the electrical outlet on the front of the power supply.
- b) Connect the other end of the power cable to an AC power source.
 - For no power redundancy, connect one power supply to one power source.
 - For n+1 redundancy, connect two power supplies to one or two power sources.
 - For n+n redundancy, connect each of two power supplies to a different power source.

Note Depending on the outlet receptacle on your power distribution unit, you might need the optional jumper cable to connect the switch to your outlet receptacle.

- c) Verify that the power supply is operational by checking that the power supply OK LED is green.

Replacing a Supervisor Module

This procedure can proceed without unplugging the switch.



Warning Statement 1034—Backplane Voltage

Hazardous voltage or energy is present on the backplane when the system is operating. Use caution when servicing.



Warning Statement 1051—Laser Radiation

Invisible laser radiation may be emitted from disconnected fibers or connectors. Do not stare into beams or view directly with optical instruments.

Before you begin

- Wear electrostatic discharge (ESD) wrist strap or other ESD protective device while handling modules.
 - Prepare an antistatic surface or packing materials for each module that you remove from the chassis.
-

Step 1 Open the packaging for the new module and inspect the module for damage.

For a damaged module, contact the Technical Assistance Center (TAC).

Step 2 If you are replacing a module that is currently in the chassis, remove the existing module from the chassis by following these steps:

Note Disconnect and label each of the interface cables from the module.

- a) Loosen the thumb-screw on the module to release the module from the chassis as shown in the following figure.
- b) Press the latch down, to release the latch from the chassis as shown in the following figure.
- c) Rotate the latch away from the module to disengage from the chassis as shown in the following figure.
- d) Holding the latch release lever handle, pull the module out of the chassis as shown in the following figure.

Figure 6: Supervisor Module Latch Release Lever

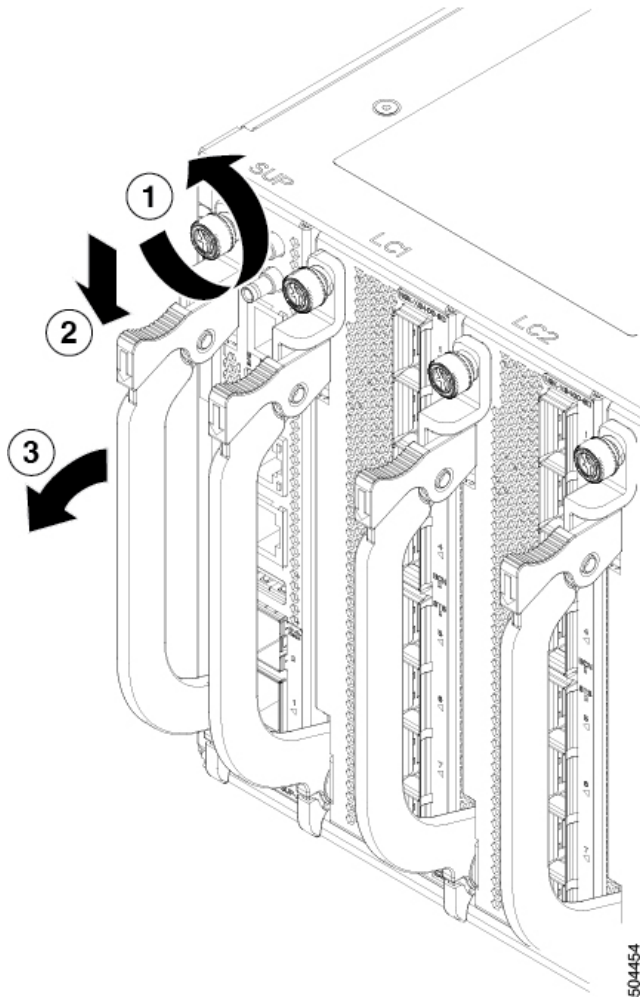

1	Loosen the thumb-screw on the module.	2	Press the latch down to release the latch from the chassis.
3	Rotate the latch away from the module to disengage from the chassis.	4	Pull the module out of the chassis.

Step 3

To install the module, follow these steps:

- a) Make sure that the lever is in the fully open position.
- b) Hold the module with one hand and place your other hand under the module to support its weight.
- c) Align the module with the open slot and gently slide the module into the slot until the lever's clamp engages with the chassis. Then rotate the lever up and toward the chassis until it clicks into the fully closed position .
- d) Tighten the module thumb-screws.

Note Attach each interface cable to the appropriate port on the module. Use the label on each cable to determine to which port each cable attaches.

Installing or Replacing a Line-Card Expansion Module (LEM)

The switch can operate with one or more Line-card Expansion Modules (LEMs) installed in the chassis. If there is at least one LEM installed and operating in the chassis, you can replace another LEM or install a new LEM in an empty slot.



Note **Limitation:** N9K-X9400-16W has a limitation on link bring up for 10G/40G and 10G/100G when connecting ports that are next to each other.

if port 1 is connected with 10G, and if 40G or 100G is connected in port2 then port 2 will be `hw-disabled`. To recover port 2 from `hw-disabled`, you need to remove 10G from port 1 and you need to do OIR once on port-2

```
Eth4/3 -- hwdisabled trunk full inherit QSFP-H40G-CU5M
Eth4/4 -- connected routed full 10G SFP-H10GB-AOC1M
```

```
ifav132-leaf18-sl# show int ethernet 4/3-4 status
Eth4/3 -- out-of-ser trunk full 40G QSFP-H40G-CU5M
Eth4/4 -- hwdisabled routed full inherit SFP-H10GB-AOC1M
```

```
ifav132-leaf18-sl# show int ethernet 6/7-8 status
```

```
-----
Port Name Status Vlan Duplex Speed Type
-----
```

```
Eth6/7 -- out-of-ser trunk full 10G 10Gbase-SR
Eth6/8 -- hwdisabled trunk full inherit QSFP-100G-CWDM4
ifav132-leaf18-sl# show int ethernet 6/7-8 status
```

```
-----
Port Name Status Vlan Duplex Speed Type
-----
```

```
Eth6/7 -- hwdisabled trunk full inherit 10Gbase-SR
Eth6/8 -- out-of-ser trunk full 100G QSFP-100G-CWDM4
-----
```



Caution Once a LEM is removed, you must wait at least 10 seconds before you insert a new one. Once the LEM is inserted, the `retimer init` program will be started in MIFPGA. Any removal or disturbance would cause `retimer` cannot access LEM MIFPGA and a crash can happen.



Warning **Statement 1034**—Backplane Voltage

Hazardous voltage or energy is present on the backplane when the system is operating. Use caution when servicing.



Warning Statement 1051—Laser Radiation

Invisible laser radiation may be emitted from disconnected fibers or connectors. Do not stare into beams or view directly with optical instruments.

Before you begin

- Wear electrostatic discharge (ESD) wrist strap or other ESD protective device while handling modules.
- Prepare an antistatic surface or packing materials for each module that you remove from the chassis.

Step 1 Open the packaging for the new LEM and inspect the module for damage.

For a damaged module, contact the Technical Assistance Center (TAC).

Step 2 If you are installing the module in a slot with a blank module, remove the blank module (N9K-C9400-BLK) that is already in that slot.

Step 3 If you are replacing a module that is currently in the chassis, remove the existing module from the chassis by following these steps:

Note Disconnect and label each of the interface cables from the module.

- a) Loosen the thumb-screw on the LEM to release the LEM from the chassis as shown in the following figure.
- b) Press the latch down, to release the latch from the chassis as shown in the following figure.
- c) Rotate the latch away from the module to disengage from the chassis as shown in the following figure.
- d) Holding the latch release lever handle, pull the module out of the chassis as shown in the following figure.

Figure 7: Line-Card Expansion Module Latch Release Lever

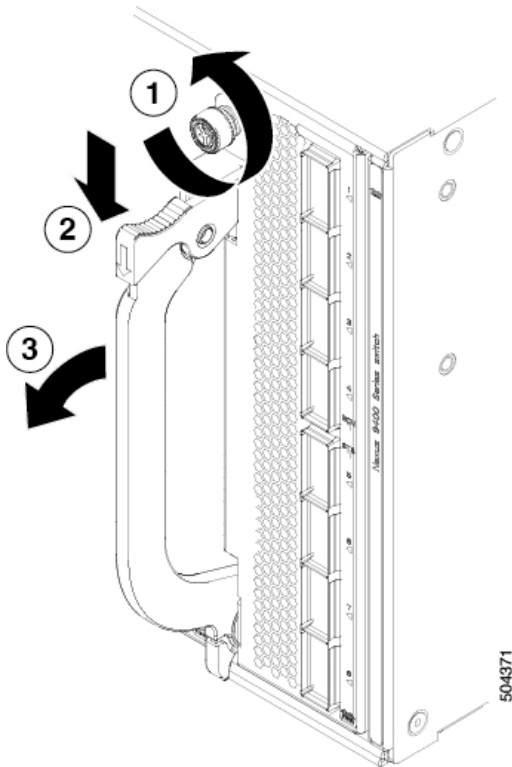

1	Loosen the thumb-screw on the LEM.	2	Press the latch down to release the latch from the chassis.
3	Rotate the latch away from the module to disengage from the chassis.	4	Pull the module out of the chassis.

Step 4 To install the module, follow these steps:

- a) Make sure that the LEM lever is in the fully open position.
- b) Hold the module with one hand and place your other hand under the module to support its weight.
- c) Align the module with the open slot and gently slide the module into the slot until the lever's clamp engages with the chassis. Then rotate the lever up and toward the chassis until it clicks into the fully closed position .
- d) Tighten the LEM thumb-screw.

Note Attach each interface cable to the appropriate port on the module. Use the label on each cable to determine to which port each cable attaches.

Replacing a Switch Card

The Switch Card is hot-swappable. It is not necessary to shut down the switch before replacing the module.



Warning Statement 1034—Backplane Voltage

Hazardous voltage or energy is present on the backplane when the system is operating. Use caution when servicing.

Before you begin

- Wear electrostatic discharge (ESD) wrist strap or other ESD protective device while handling the module.
- Prepare an antistatic surface or packing materials for the module that you remove from the chassis.

Step 1 Open the packaging for the new Switch Card and inspect the module for damage.

For a damaged module, contact the Technical Assistance Center (TAC).

Step 2 To remove the module follow these steps:

- a) Loosen the thumb screws that attach the module to the chassis (4), as shown in the following figure.
- b) Push the lever button (2) to release the lever, as shown in the following figure.
- c) Disengage the lever (2) by pulling it out and away from the chassis, as shown in the following figure.
- d) Carefully remove the module.

Figure 8: Switch Card Replacement

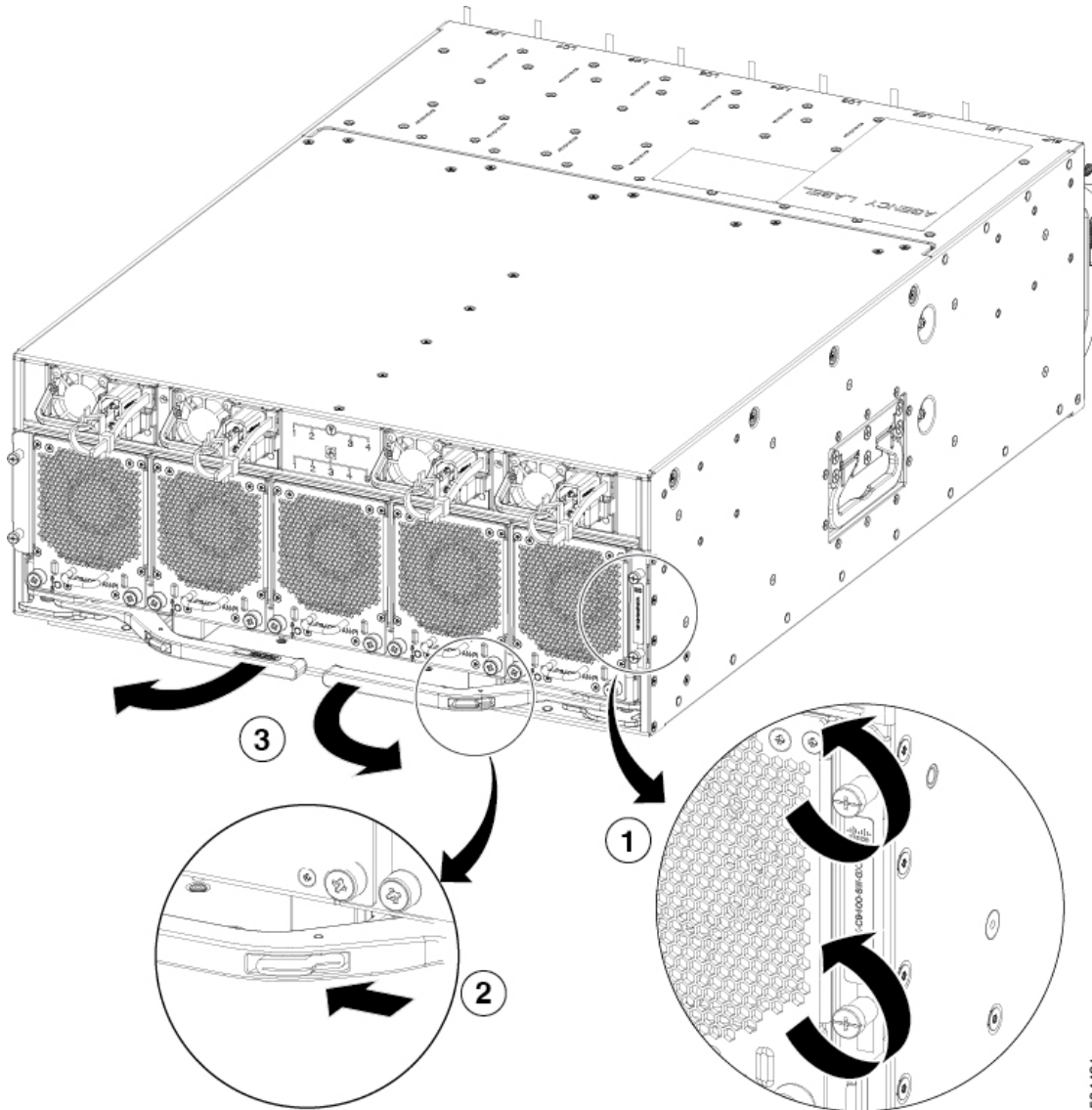

504421

1	Loosen the thumb screws (2 each side of the chassis)	2	Push the lever button (1 each lever)
3	Disengage the lever (2)		

Step 3

To install the module, follow these steps:

- a) Make sure that each lever is in the fully open position.
- b) Use both hands, one on the left side and one on the right side of the module, to support its weight.
- c) Align the module with the open slot and gently slide the module into the slot until the lever's clamp touches the chassis. Then engage the levers by pushing them toward the chassis until it clicks into place, reaching the fully closed position..

- d) Tightening the thumb screws.
-

Fiber Optic Removal Using the Optics Extraction Tool

Management port fiber optics cannot be removed unless the Supervisor LEM ejector is pulled out. This will cause a Supervisor reset.

Before you begin

Ensure that before you handle any switch components, you are wearing a grounded electrostatic discharge (ESD) strap. To ground the strap, attach it directly to earth ground or to a grounded rack or chassis. There must be a metal-to-metal connection to earth ground.

Step 1 Remove the fiber-optic cables from the transceiver module before removing the transceiver module.

Step 2 Use the optics extraction tool to carefully disengage the latch and remove the transceiver module (see the following

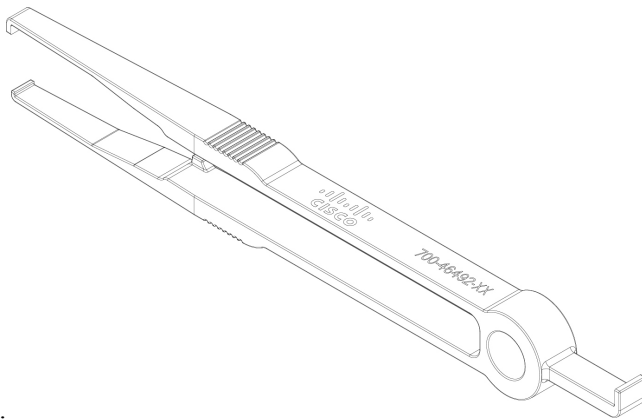

image).

Step 3 Place the transceiver module in an antistatic bag or other protective environment.



CHAPTER 6

Managing the Switch

- [Displaying Information About the Installed Hardware Modules, on page 45](#)
- [Displaying the Hardware Inventory for the Switch, on page 48](#)
- [Displaying the Modules for the Switch, on page 49](#)
- [Displaying the Serial PROM \(SPROM\) for the Switch, on page 50](#)
- [Displaying Environmental Information for the Switch, on page 51](#)
- [Displaying Environment Temperature for the Switch, on page 52](#)

Displaying Information About the Installed Hardware Modules

You can display information about the switch hardware and the hardware modules that are installed in the switch by using the **show hardware** command.

```
ASW4_QP_LEM# show hardwareCisco Nexus Operating System (NX-OS) Software
TAC support: http://www.cisco.com/tac
Copyright (C) 2002-2022, Cisco and/or its affiliates.
All rights reserved.
The copyrights to certain works contained in this software are
owned by other third parties and used and distributed under their own
licenses, such as open source. This software is provided "as is," and unless
otherwise stated, there is no warranty, express or implied, including but not
limited to warranties of merchantability and fitness for a particular purpose.
Certain components of this software are licensed under
the GNU General Public License (GPL) version 2.0 or
GNU General Public License (GPL) version 3.0 or the GNU
Lesser General Public License (LGPL) Version 2.1 or
Lesser General Public License (LGPL) Version 2.0.
A copy of each such license is available at
http://www.opensource.org/licenses/gpl-2.0.php and
http://opensource.org/licenses/gpl-3.0.html and
http://www.opensource.org/licenses/lgpl-2.1.php and
http://www.gnu.org/licenses/old-licenses/library.txt.

Software
  BIOS: version 01.09
  NXOS: version 10.3(2) [Feature Release]
  Host NXOS: version 10.3(2)
  BIOS compile time: 09/28/2022
  NXOS image file is: bootflash:///nxos64-cs.10.3.2.F.bin_24
  NXOS compile time: 11/30/2022 12:00:00 [12/16/2022 04:02:06]
  NXOS boot mode: LXC
```

Hardware

```

cisco Nexus9000 C9408 Chassis
Intel(R) Xeon(R) CPU D-1633N @ 2.50GHz with 32801260 kB of memory.
Processor Board ID FDO262208WX
Device name: ASW4_QP_LEM
bootflash: 115343360 kB

```

```
Kernel uptime is 2 day(s), 22 hour(s), 9 minute(s), 16 second(s)
```

```

Last reset at 282926 usecs after 1671239402
Reason: Reset Requested by CLI command reload
System version: 10.3(2)
Service:

```

```

plugin
  Core Plugin, Ethernet Plugin
-----
Switch hardware ID information
-----

```

```

Switch is booted up
Switch type is : Nexus9000 C9408 Chassis
Model number is N9K-C9408
H/W version is 0.1
Part Number is 73-102375-03
Part Revision is 03
Manufacture Date is Year 2022 Week 21
Serial number is FDO262100LC
CLEI code is 0

```

```
-----
Chassis has 8 Module slots
-----
```

```

Module1 ok
Module type is : "Supervisor"
0 submodules are present
Model number is
H/W version is 0.0
Part Number is
Part Revision is
Manufacture Date is Year 1996 Week 0
Serial number is
CLEI code is

```

```
LEM-Module1 empty
```

```

LEM-Module2 ok
LEM-Module type is : 8x400G Ethernet Module
0 submodules are present
Model number is N9K-X9400-8D
H/W version is 0.3
Part Number is 73-102376-03
Part Revision is 07
Manufacture Date is Year 2022 Week 22
Serial number is FDO26221BA7
CLEI code is 0

```

```

LEM-Module3 ok
LEM-Module type is : 16x200G Ethernet Module
0 submodules are present
Model number is N9K-X9400-16W
H/W version is 0.3
Part Number is 73-102377-03
Part Revision is 07
Manufacture Date is Year 2022 Week 22

```

```
Serial number is FDO262213VA  
CLEI code is 0
```

```
LEM-Module4 empty
```

```
LEM-Module5 ok  
LEM-Module type is : 8x400G Ethernet Module  
0 submodules are present  
Model number is N9K-X9400-8D  
H/W version is 0.3  
Part Number is 73-102376-03  
Part Revision is 07  
Manufacture Date is Year 2022 Week 22  
Serial number is FDO26221BAK  
CLEI code is 0
```

```
LEM-Module6 empty
```

```
LEM-Module7 ok  
LEM-Module type is : 16x200G Ethernet Module  
0 submodules are present  
Model number is N9K-X9400-16W  
H/W version is 0.3  
Part Number is 73-102377-03  
Part Revision is 07  
Manufacture Date is Year 2022 Week 22  
Serial number is FDO262213VQ  
CLEI code is 0
```

```
LEM-Module8 empty
```

```
-----  
Chassis has 4 PowerSupply Slots  
-----
```

```
PS1 fail/shutdown  
Power supply type is: 2000.00W 220v AC  
Model number is NXA-PAC-2KW-PI  
H/W version is 0  
Part Number is 341-1888-01  
Part Revision is A0  
Manufacture Date is Year 2021 Week 47  
Serial number is POG2547JACK  
CLEI code is CMUPAFGCAA
```

```
PS2 fail/shutdown  
Power supply type is: 2000.00W 220v AC  
Model number is NXA-PAC-2KW-PI  
H/W version is 0  
Part Number is 341-1888-01  
Part Revision is A0  
Manufacture Date is Year 2021 Week 47  
Serial number is POG2547JA1Q  
CLEI code is CMUPAFGCAA
```

```
PS3 fail/shutdown  
Power supply type is: 2000.00W 220v AC  
Model number is NXA-PAC-2KW-PI  
H/W version is 0  
Part Number is 341-1888-01  
Part Revision is A0  
Manufacture Date is Year 2021 Week 47  
Serial number is POG2547JAH6  
CLEI code is CMUPAFGCAA
```

```

PS4 ok
Power supply type is: 2000.00W 220v AC
Model number is NXA-PAC-2KW-PI
H/W version is 0
Part Number is 341-1888-01
Part Revision is A0
Manufacture Date is Year 2021 Week 47
Serial number is POG2547JA20
CLEI code is CMUPAFGCAA

```

```

-----
Chassis has 5 Fan slots
-----

```

```
Fan1 ok
```

```
Fan2 ok
```

```
Fan3 ok
```

```
Fan4 ok
```

```
Fan5 ok
```

```
ASW4_QP_LEM#
```

Displaying the Hardware Inventory for the Switch

You can display information about the field replaceable units (FRUs), that are installed in the switch by using the **show inventory** command.

```

ASW4_QP_LEM# show inventory
NAME: "Chassis",  DESCR: "Nexus9000 C9408 Chassis"
PID: N9K-C9408      ,  VID: V00 ,  SN: FDO262100LC

NAME: "Switch Card",  DESCR: "Switch Card"
PID: N9K-C9400-SW-GX2A  ,  VID: V00 ,  SN: FDO262200E1

NAME: "Slot 1",  DESCR: "Supervisor"
PID: N9K-C9400-SUP-A    ,  VID: V00 ,  SN: FDO262208WX

NAME: "Slot 27",  DESCR: "Supervisor"
PID: N9K-C9400-SUP-A    ,  VID: V00 ,  SN: FDO262208WX

NAME: "LEM 2",  DESCR: "8x400G Ethernet Module"
PID: N9K-X9400-8D      ,  VID: V00 ,  SN: FDO26221BA7

NAME: "LEM 3",  DESCR: "16x200G Ethernet Module"
PID: N9K-X9400-16W     ,  VID: V00 ,  SN: FDO262213VA

NAME: "LEM 5",  DESCR: "8x400G Ethernet Module"
PID: N9K-X9400-8D      ,  VID: V00 ,  SN: FDO26221BAK

NAME: "LEM 7",  DESCR: "16x200G Ethernet Module"
PID: N9K-X9400-16W     ,  VID: V00 ,  SN: FDO262213VQ

NAME: "Power Supply 1",  DESCR: "Nexus9000 C9408 Chassis Power Supply"
PID: NXA-PAC-2KW-PI    ,  VID: V01 ,  SN: POG2547JACK

NAME: "Power Supply 2",  DESCR: "Nexus9000 C9408 Chassis Power Supply"
PID: NXA-PAC-2KW-PI    ,  VID: V01 ,  SN: POG2547JA1Q

```

```

NAME: "Power Supply 3",  DESCR: "Nexus9000 C9408 Chassis Power Supply"
PID: NXA-PAC-2KW-PI      ,  VID: V01 ,  SN: POG2547JAH6

NAME: "Power Supply 4",  DESCR: "Nexus9000 C9408 Chassis Power Supply"
PID: NXA-PAC-2KW-PI      ,  VID: V01 ,  SN: POG2547JA20

NAME: "Fan 1",  DESCR: "Nexus9000 C9408 Chassis Fan Module"
PID: N9K-C9400-FAN-PI    ,  VID: V01 ,  SN: N/A

NAME: "Fan 2",  DESCR: "Nexus9000 C9408 Chassis Fan Module"
PID: N9K-C9400-FAN-PI    ,  VID: V01 ,  SN: N/A

NAME: "Fan 3",  DESCR: "Nexus9000 C9408 Chassis Fan Module"
PID: N9K-C9400-FAN-PI    ,  VID: V01 ,  SN: N/A

NAME: "Fan 4",  DESCR: "Nexus9000 C9408 Chassis Fan Module"
PID: N9K-C9400-FAN-PI    ,  VID: V01 ,  SN: N/A

NAME: "Fan 5",  DESCR: "Nexus9000 C9408 Chassis Fan Module"
PID: N9K-C9400-FAN-PI    ,  VID: V01 ,  SN: N/A

ASW4_QP_LEM#

```

Displaying the Modules for the Switch

You can display information about the modules, that are installed in the switch by using the **show module** command.

```

switch# show module
Mod Ports      Module-Type          Model                Status
-----
1      0      Supervisor          N9K-C9408-SUP-A     active *
27     0      Virtual Supervisor  N9K-C9400-SUP-A     active *

Mod Sw          Hw   Slot
-----
1      10.3(2)       0.4  LC1
27     10.3(2)       0.4  SUP1

Mod  MAC-Address(es)          Serial-Num
-----
1      60-26-aa-48-c8-40 to 60-26-aa-48-c8-7f  FDO262208WX
27     60-26-aa-48-c8-40 to 60-26-aa-48-c8-7f  FDO262208WX

Mod  Online Diag Status
-----
1      Pass
27     Pass

* this terminal session
Lem Ports      Module-Type          Model                Status
-----
1      16      16x200G Ethernet Module  N9K-X9400-8D        ok
2      8       8x400G Ethernet Module  N9K-X9400-8D        ok
4      8       8x400G Ethernet Module  N9K-X9400-16W       ok

Mod Sw          Hw   Slot
-----

```

```

1    NA                0.1010 LC1
2    NA                0.1010 LC2
4    NA                0.1010 LC4

Lem  MAC-Address(es)                Serial-Num
---  -----
1    0c-75-bd-37-2c-fe to 0c-75-bd-37-2d-1d  FOC223620GT
2    0c-75-bd-37-2d-1e to 0c-75-bd-37-2d-3d  FOC224291Q8
4    0c-75-bd-37-2d-5e to 0c-75-bd-37-2d-7d  FOC224291TA

Lem  Online Diag Status
---  -----
1    Pass
2    Pass
4    Pass
switch#

```

Displaying the Serial PROM (SPROM) for the Switch

You can display information about the SPROM, for the switch by using the **show sprom** command.

```

switch# show sprom backplane 1
DISPLAY backplane sprom contents:
Common block:
Block Signature : 0xABAB
Block Version   : 3
Block Length    : 160
Block Checksum  : 0x168E
EEPROM Size     : 65535
Block Count     : 3
FRU Major Type  : 0x6002
FRU Minor Type  : 0x0
OEM String      : Cisco Systems, Inc
Product Number  : N9K-C9408
Serial Number   : FOC23086N6A
Part Number     : 73-19248-01
Part Revision   : 1
Mfg Deviation   : 0
H/W Version     : 0.0
Mfg Bits        : 0
Engineer Use    : 0
snmpOID        : 9.12.3.1.3.1824.0.0
Power Consump   : -6200
RMA Code        : 0-0-0-0
CLEI Code       : 12345678
VID             : V01
Chassis specific block:
Block Signature : 0x6001
Block Version   : 3
Block Length    : 39
Block Checksum  : 0x419
Feature Bits    : 0x0
HW Changes Bits : 0x0
Stackmib OID    : 0
MAC Addresses   : 00-00-ab-cd-dc-ba
Number of MACs  : 128
OEM Enterprise  : 0
OEM MIB Offset  : 0
MAX Connector Power: 0
WWN software-module specific block:
Block Signature : 0x6005

```



```

Block Version      : 1
Block Length       : 0
Block Checksum     : 0x66
wnn usage bits:
00 00 00 00 00 00 00 00
00 00 00 00 00 00 00 00
00 00 00 00 00 00 00 00
00 00 00 00 00 00 00 00
00 00 00 00 00 00 00 00
00 00 00 00 00 00 00 00
00 00 00 00 00 00 00 00
00 00 00 00 00 00 00 00
00 00 00 00 00 00 00 00
00 00 00 00 00 00 00 00
00 00 00 00 00 00 00 00
00 00 00 00 00 00 00 00
00 00 00 00 00 00 00 00
00 00 00 00 00 00 00 00
00 00 00 00 00 00 00 00
00 00 00 00 00 00 00 00
00 00 00 00 00 00 00 00
00 00 00 00 00 00 00 00
00 00 00 00 00 00 00 00
00 00 00 00 00 00 00 00
00 00 00 00 00 00 00 00
00 00 00 00 00 00 00 00
00 00 00 00 00 00 00 00
00 00 00 00 00 00 00 00
00 00 00 00 00 00 00 00
00 00
License software-module specific block:
Block Signature    : 0x0
Block Version      : 0
Block Length       : 0
Block Checksum     : 0x0
lic usage bits:
00 00 00 00 00 00 00 00
Second Serial number specific block:
Block Signature    : 0x0
Block Version      : 0
Block Length       : 0
Block Checksum     : 0x0
Serial Number      :
switch#

```

Displaying Environmental Information for the Switch

You can display information about the environment, for the switch by using the **show environment** command.

```
switch# show environment
```

```
Fan:
```

```

-----
Fan           Model           Hw    Direction      Status
-----
Fan1(sys_fan1)  N9K-C9400-FAN-PI  --    front-to-back  Ok
Fan2(sys_fan2)  N9K-C9400-FAN-PI  --    front-to-back  Ok

```

```

Fan3(sys_fan3) N9K-C9400-FAN-PI -- front-to-back Ok
Fan4(sys_fan4) N9K-C9400-FAN-PI -- front-to-back Ok
Fan5(sys_fan5) N9K-C9400-FAN-PI -- front-to-back Ok
Fan_in_PS1 -- -- front-to-back Ok
Fan_in_PS2 -- -- front-to-back Ok
Fan_in_PS3 -- -- front-to-back Ok
Fan_in_PS4 -- -- front-to-back Ok
Fan Zone Speed: Zone 1: 0x72
Fan Air Filter : NotSupported

```

```

Power Supply:
Voltage: 12 Volts
Power
Supply      Model                Actual      Actual      Total
              Output          Input      Capacity    Status
              (Watts )          (Watts )    (Watts )
-----
1          NXA-PAC-2KW-PI          507 W      552 W      2000 W      Ok
2          NXA-PAC-2KW-PI          555 W      603 W      2000 W      Ok
3          NXA-PAC-2KW-PI          506 W      552 W      2000 W      Ok
4          NXA-PAC-2KW-PI          507 W      552 W      2000 W      Ok

```

Power Usage Summary:

```

-----
Power Supply redundancy mode (configured)          PS-Redundant
Power Supply redundancy mode (operational)        PS-Redundant

```

```

Total Power Capacity (based on configured mode)          6000.00 W
Total Grid-A (first half of PS slots) Power Capacity    4000.00 W
Total Grid-B (second half of PS slots) Power Capacity   4000.00 W
Total Power of all Inputs (cumulative)                   8000.00 W
Total Power Output (actual draw)                         2075.00 W
Total Power Input (actual draw)                          2259.00 W
Total Power Allocated (budget)                           N/A
Total Power Available for additional modules              N/A

```

Temperature:

```

-----
Module  Sensor          MajorThresh  MinorThres  CurTemp    Status
              (Celsius)    (Celsius)   (Celsius)
-----
1       FRONT          55           35          35         Ok
1       BACK           80           70          36         Ok
1       CPU            90           80          55         Ok
1       Quadpeaks     125          100         81         Ok
ASW4_QP_LEM#

```

Displaying Environment Temperature for the Switch

You can display information about the environment, for the switch by using the **show environment temperature** command.

```

ASW4_QP_LEM# show environment temperature
show environment temperature
Temperature:

```

```

-----
Module  Sensor          MajorThresh  MinorThres  CurTemp    Status
              (Celsius)    (Celsius)   (Celsius)
-----

```

1	FRONT	55	35	35	Ok
1	BACK	80	70	36	Ok
1	CPU	90	80	49	Ok
1	Quadpeaks	125	100	81	Ok

ASW4_QP_LEM#



APPENDIX A

Rack Specifications

- [General Requirements and Guidelines for Cabinets and Racks, on page 55](#)
- [About Requirements for Perforated Cabinets, on page 56](#)
- [About Requirements for Open Racks, on page 56](#)

General Requirements and Guidelines for Cabinets and Racks

The cabinet or rack must have all of the following characteristics:

- Standard 19-inch (48.3 cm) four-post EIA cabinet or rack.
- Mounting rails that conform to English universal hole spacing per section 1 of ANSI/EIA-310-D-1992). See below.

The cabinet or rack must also meet the following requirements:

- The minimum vertical rack space per Cisco Nexus switch chassis must be one RU (rack units), equal to 1.75 inches (4.4 cm).
- The width between the rack-mounting rails must be at least 17.75 inches (45.0 cm) if the rear of the device is not attached to the rack. For four-post EIA racks, this measurement is the distance between the two front rails.

Four-post EIA cabinets (perforated or solid-walled) must meet the following requirements:

- The minimum spacing for the bend radius for fiber-optic cables should have the front-mounting rails of the cabinet offset from the front door by a minimum of 3 inches (7.6 cm).
- The distance between the outside face of the front mounting rail and the outside face of the back mounting rail should be 23.0 to 30.0 inches (58.4 to 76.2 cm) to allow for rear-bracket installation.
- A minimum of 2.5 inches (6.4 cm) of clear space should exist between the side edge of the chassis and the side wall of the cabinet. No sizeable flow obstructions should be immediately in the way of chassis air intake or exhaust vents.



Note To help with cable management, consider planning additional space in the rack or cabinet above and below the chassis to make it easier to route all of the fiber optic or copper cables through the rack.

About Requirements for Perforated Cabinets

A perforated cabinet has perforations in its front and rear doors and side walls. In addition to the requirements listed in the “General Requirements for Cabinets and Racks” section, perforated cabinets must meet the following requirements:

- The front and rear doors must have at least a 60-percent open area perforation pattern, with at least 15 square inches (96.8 square cm) of open area per rack unit of door height.
- The roof should be perforated with at least a 20-percent open area.
- The cabinet floor should be open or perforated to enhance cooling.

The Cisco R Series rack conforms to these requirements.

About Requirements for Open Racks

In addition to the requirements listed in the “General Requirements for Cabinets and Racks” section on page A-1, if you are mounting the chassis in an open rack (no side panels or doors), ensure that the rack meets the following requirements:

- The minimum vertical rack space per chassis must be two rack units (RU), equal to 3.47 inches (8.8 cm).
- The horizontal distance between the chassis and any adjacent chassis should be 6 inches (15.2 cm), and the distance between the chassis air vents and any walls should be 2.5 inches (6.4 cm).



APPENDIX **B**

System Specifications

- [Environmental Specifications, on page 57](#)
- [Switch Dimensions, on page 57](#)
- [Switch and Module Weights, on page 58](#)
- [2000-W AC Power Supply Specifications, on page 58](#)
- [AC Power Cable Specifications, on page 58](#)

Environmental Specifications

Environment		Specification
Temperature	Ambient operating temperature	32 to 104°F (0 to 40°C)
	Ambient nonoperating	–40 to 158°F (–40 to 70°C)
Humidity	Ambient operating	5 to 90%
	Ambient nonoperating	5 to 95%
Altitude	Ambient operating altitude	0 to 5,000 feet (0 to 1524 m)
	Ambient nonoperating	–1000 to 30,000 feet (–304 to 15,150 m)

Switch Dimensions

Switch Component	Height	Width	Depth
Cisco Nexus 9408 chassis	6.97 inches (17.7 cm) (4 RU)	17.3 inches (43.9 cm)	23.62 inches (59.99 cm)

Switch and Module Weights

Component	Weight per Unit
Cisco Nexus 9408 Chassis (N9K-C9408)	121.25 lb (55 kg)
Fan Module	—
– Port-side intake (burgundy) (N9K-C9400-FAN-PI)	1.35 lb (0.61 kg)
Power Supplies	—
– 2000-W AC port-side intake (burgundy) (NXA-PAC-2KW-PI)	2.42 lb (1.1 kg)

2000-W AC Power Supply Specifications

These specifications apply to the following power supplies:

- NXA-PAC-2KW-PI

Property	Specification
Power	2000 W
Input Voltage	200-240 VAC, 12A, 50/60 Hz
Frequency	50 to 60 Hz
Efficiency	90% or greater (20 to 100% load)
Redundancy Modes	Combined, $n+1$, and $n+n$
RoHS Compliance	Yes
Hot Swappable	Yes
Airflow Direction	Port-side intake airflow

AC Power Cable Specifications

Cable	Description	Length
SFS-250V-10A-AR (Argentina)	250 VAC 10 A, IRAM 2073 plug	8.2 feet (2.5 m)
CAB-9K10A-AU (Australia)	250 VAC 10 A, 3112 plug	8.2 feet (2.5 m)
SFS-250V-10A-CN (China)	250 VAC 10 A, GB 2009 plug	8.2 feet (2.5 m)
CAB-9K10A-EU (Europe)	250 VAC 10 A, M 2511 plug	8.2 feet (2.5 m)

Cable	Description	Length
SFS-250V-10A-ID (South Africa, United Arab Emerits, and India)	250 VAC 16 A, EL-208 plug	8.2 feet (2.5 m)
SFS-250V-10A-IS (Israel)	250 VAC 10 A, SI-32 plug	8.2 feet (2.5 m)
CAB-9K10A-IT (Italy)	250 VAC 10 A, CEI 23-16 plug	8.2 feet (2.5 m)
CAB-9K10A-SW (Switzerland)	250 VAC 10 A, MP232 plug	8.2 feet (2.5 m)
CAB-9K10A-UK (United Kingdom)	250 VAC 10 A, BS1363 plug (13-A fuse)	8.2 feet (2.5 m)
CAB-AC-250V/13A (North America)	250 VAC 13 A, NEMA L6-20 plug	6.6 feet (2.0 m)
CAB-N5K6A-NA (North America)	250 VAC 10 A, NEMA 6-15 plug	8.2 feet (2.5 m)
CAB-9K12A-NA (North America)	125 VAC 13 A, NEMA 5-15 plug	8.2 feet (2.5 m)
CAB-C13-CBN	250 VAC 10 A, SS 10-A plug	8.2 feet (2.5 m)
CAB-C13-C14-2M	Cabinet Jumper Power Cord, 250 VAC 10 A, C13-C14 Connectors	6.6 feet (2 m)
CAB-C13-C14-AC	Cabinet Jumper Power Cord, 250 VAC 10 A, C13-C14 Connectors	9.8 feet (3 m)
CAB-C13-C14-JMPR	Cabinet Jumper Power Cord 250 VAC 13 A, C13-C14 Connectors	2.2 feet (0.7 m)
CAB-IND-10A	250 VAC 10 A, EL-208B plug	8.2 feet (2.5 m)



APPENDIX **C**

LEDs

- [CPU Card LEDs, on page 61](#)
- [LEM LEDs, on page 62](#)
- [Fan LEDs, on page 63](#)
- [Power Supply LEDs, on page 64](#)

CPU Card LEDs

This table provides information about CPU Card LEDs for Cisco Nexus 9400 Series switches.

Component	LED	Status	Description
CPU Card (N9K-C9400-SUP-A)	BCN	Blinking (blue)	The operator has activated this LED to identify the chassis.
		Off	This module is not being identified.
	STS	Solid on (green)	All diagnostics pass. The module is operational.
		Blinking (amber)	The module is booting up.
		On (amber)	The module is not receiving power.
		Solid on (red)	Temperature exceeds the minor alarm threshold.
	ENV	Solid on (green)	Temperature exceeds the major alarm threshold.
		Solid on (amber)	Fans and power supply modules are operational.
	SYNCE	Solid on (green)	At least one fan or power supply module is not operational.
		Solid on (amber)	Synchronization of the frequency to external interface could be (GPS, Recovered RX clk).
		Off	Freerun/holdover- Time core is in freerun or holdover.
	TIMING	Solid on (green)	Time core clock synchronization is disabled.
		Solid on (amber)	Synchronization of the time and phase to external interface could be (GPS, FP).
		Off	Freerun/holdover- Time core is in freerun or holdover.
	GPS	Solid (green)	Time core clock synchronization is disabled.
		Off	GPS interface provisioned and ports are turned on. ToD, 1PPS, 10MHz are all valid.
	MGMT link	Off	Either the interface is not provisioned, or the ports are not turned on. ToD, 1PPS, 10MHz are not valid.
		Solid (green)	The MGMT port is link up.
	MGMT activity	Off	The MGMT port is not link up.
		Blinking (green)	The MGMT port is transmitting or receiving.
	Off	The MGMT port is not transmitting or receiving.	

LEM LEDs

This table provides information about Line Expansion Module (LEM) LEDs for Cisco Nexus 9400 Series switches.

Component	LED	Status	Description
LEM	STS	Solid on (green)	All diagnostics pass. This module is operational.
		Solid on (amber)	<ol style="list-style-type: none"> 1. This module has detected a slot ID parity error and will not power on or boot up. 2. The module is not fully inserted. 3. The diagnostic test has failed.
		Blinking (amber)	<ol style="list-style-type: none"> 1. This module has just been powered on, and the module is resetting. 2. The module is resetting and both ejector levers are out. 3. The module has been inserted during the initialization process (transition state). 4. The module could not power up because of insufficient power. 5. An over-temperature condition has occurred. A major temperature threshold has been exceeded.
		Off	This module is not receiving power.
	BCN	Blinking (blue)	The operator has activated this LED to identify this module in the chassis.
		Off	This module is not being identified
	Port	Solid on (green)	The port is active and the link is up.
		Solid on (yellow)	The port is disabled by the operator or is not initializing.
		Blinking (yellow)	The port is faulty and disabled.
		Off	The port is not active or the link is not connected.

Fan LEDs

This table provides information about fan LEDs for Cisco Nexus 9400 Series switches.

Component	LED	Status	Description
Fan	Status	Solid on (green)	All diagnostics pass. The module is operational.
		Off	The module is not receiving power.
		Solid on (amber)	The module is booting or running diagnostics.
		Blinking (amber)	If the module fails during an initial reset, the LED continues to blink and the module does not come online. The module has a runtime failure and is brought offline.

Power Supply LEDs

This table provides information about power supply LEDs for Cisco Nexus 9400 Series switches.

Component	LED	Status	Description
Power supply	OK (green)	Solid on	Power supply is on and okay.
		Blinking	3.3 voltage standby (VSB) is on but the power supply unit is not powering the other modules.
		Off	No power to the power supply.
	FAULT (amber)	Solid on	Power supply failure, overvoltage, overcurrent, or overheating.
		Blinking	Power is present, 3.3 VSB on, and the power supply is off. PSU fan rotor is not functioning normally.
		Off	Operating normally.



APPENDIX **D**

Spare Parts Table

- [Spares Support Table, on page 65](#)

Spares Support Table

Product	Chassis Height (Rack Units)	Power Supply Options	Fan Options	Module Options	Accessory Kits
Nexus 9408	4 RU	AC port-side intake (NXA-PAC-2KW-PI)	Port-side intake (N9K-C9400-FAN-PI)	CPU Card (N9K-C9400-SUP-A) Switch Card (N9K-C9400-SW-GX2A) ² LEM 8p 400G (N9K-X9400-8D) LEM 16p 200G (N9K-X9400-16W)	Accessory Kit (N9K-C9400-ACK) Rack mount kit (N9K-C9400-RMK) LEM Blank (N9K-C9400-BLK)

² SFP ports (Eth10/1-2) are not supported in Nexus releases 10.3.2, 10.3.3 and 10.4.1

