

# **ACMS12 Series**

## Sub-Assembly

## Access Power Controllers

### **Models Include:**

#### **ACMS12**

- Twelve (12) Fuse Protected Outputs

#### **ACMS12CB**

- Twelve (12) PTC Protected Outputs

## **Installation Guide**

## Overview:

Altronix ACMS12 and ACMS12CB are sub-assemblies to be used in Altronix BC300, BC400, Trove 1 and Trove 2 enclosures and Maximal power units. Input power to ACMS12/ACMS12CB is to be derived from eFlow series power supplies. Access Power Controller's dual input design allows power to be steered from two (2) independent low voltage 12 or 24VDC Altronix eFlow series power supplies to twelve (12) independently controlled fuse (ACMS12) or PTC (ACMS12CB) protected outputs. Outputs are activated by an open collector sink, normally open (NO), normally closed (NC) dry trigger input, or wet output from an Access Control System, Card Reader, Keypad, Push Button, PIR, etc. ACMS12(CB) will route power to a variety of access control hardware devices including Mag Locks, Electric Strikes, Magnetic Door Holders, etc. Outputs will operate in Fail-Safe or Fail-Secure modes. The FACP Interface enables Emergency Egress, Alarm Monitoring, or may be used to trigger other auxiliary devices. The fire alarm disconnect feature is individually selectable for any or all of the twelve (12) outputs. The spade connectors allow you to daisy chain power to multiple ACMS12(CB) modules. This feature allows you to distribute the power over more outputs for larger systems.

## Specifications:

### Input Voltage:

- **Input 1:** 12 or 24VDC from eFlow series Altronix Power supply.
- **Input 2:** 12 or 24 VDC from eFlow series Altronix power supply or either 5 or 12 VDC from VR6 Regulator.
- **Input Current:**
  - **ACMS12:** 20A total
  - **ACMS12CB:** 16A total.
- Twelve (12) trigger inputs:
  - a) Normally open (NO) inputs (dry contacts).
  - b) Normally closed (NC) inputs (dry contacts).
  - c) Open collector sink inputs.
  - d) Wet Input (5VDC - 24VDC) with 10K resistor
  - e) Any combination of the above.

### Outputs:

- **ACMS12:** Fuse protected outputs rated @ 2.5A per output, non power-limited. Total output 20A max.

See *Input/Output Voltage Ratings*, pg. 7.

- **ACMS12CB:** PTC protected outputs rated @ 2A per output, Class 2 power-limited. Total output 16A max.

Do not exceed the individual power supply ratings.

See *Input/Output Voltage Ratings*, pg. 7.

Total output current should not exceed max. current rating of the power supplies employed on each input.

See *Maximum Output of Altronix Power Supplies*.

- Twelve (12) selectable independently controlled outputs or twelve (12) independently controlled Fail-Safe or Fail-Secure power outputs.
- Individual outputs may be set to OFF position for servicing (output jumper set to middle position).
- Any of the twelve (12) fuse/PTC protected power outputs are selectable to follow power Input 1 or Input 2. Output voltage of each output is the same as the input voltage of the input selected.
- See *Input/Output Voltage Ratings*, pg. 7.
- Surge suppression.

### Fire Alarm Disconnect:

- Fire Alarm disconnect (latching or non-latching) is individually selectable for any or all of the twelve (12) outputs.
- Fire Alarm disconnect input options:
  - a) Normally open [NO] or normally closed [NC] dry contact input. Polarity reversal input from FACP signaling circuit.
- FACP input WET is rated 5-30VDC 7mA.
- FACP input EOL requires 10K end of line resistor.
- FACP output relay [NC]:  
Either Dry 1A/28VDC, 0.6 Power Factor or 10K resistance with [EOL JMP] intact.

### ACMS12 Fuse Ratings:

- Main input fuses are rated 15A/32V each.
- Output fuses are rated 3A/32V.

### ACMS12CB PTC Ratings:

- Main input PTCs are rated 9A each.
- Output PTCs are rated 2.5A.

### LED Indicators:

- Blue LED indicates FACP disconnect is triggered.
- Individual voltage LED indicates 12VDC (Green) or 24VDC (Red).

### Environmental:

- Operating temperature: 0°C to 49°C ambient.
- Humidity: 20 to 93%, non-condensing.

### Mechanical:

- Board Dimensions (W x L x H approximate):  
7.65" x 4.125" x 1.25"  
(194.3mm x 104.8mm x 31.8mm).
- Product weight (approx.): 0.7 lb. (0.32 kg).
- Shipping weight (approx.): 0.95 lb. (0.43 kg).

## Installation Instructions:

Wiring methods shall be in accordance with the National Electrical Code NFPA 70/NFPA 72/ ANSI / Canadian Electrical Code / CAN/ULC-S524/ULC-S527/ULC-S537, and with all local codes and authorities having jurisdiction. Product is intended for indoor dry use only.

Refer to Sub-Assembly Installation Instruction for mounting Rev. MS050913.

**Carefully review:**

**LED Diagnostics**

(pg. 5)

**Typical Application Diagram**

(pg. 6)

**Terminal Identification Table**

(pg. 5)

**Hook-up Diagrams**

(pg. 9-10)

### Installation:

1. Mount ACMS12/ACMS12CB in the desired location/enclosure. When mounting ACMS12/ACMS12CB alone, use female/female spacers (provided). When mounting with optional VR6 voltage regulator, use female/female spacers (provided) between ACMS12/ACMS12CB and VR6 (Fig. 6, pg. 6). Attach ACMS12/ACMS12CB to spacers utilizing 5/16" pan head screws (provided).

### Connections:

2. Ensure all output jumpers [OUT1] - [OUT12] are placed in the OFF (center) position.
3. Connect low voltage DC power supplies to terminals marked [+ PWR1 -], [+ PWR2 -]
4. Set each output [OUT1] - [OUT12] to route power from Power Supply 1 or 2 (Fig. 1, pg. 3).

**Note:** Measure output voltage before connecting devices.  
This helps avoiding potential damage.

5. Turn power off before connecting devices.

### Operations:

**Important: Inputs/Outputs and their switches are grouped (Fig. 3, pg. 4).**

6. Output options: The ACMS12(CB) will provide up to twelve (12) switched power outputs

#### Switched Power outputs:

Connect the input of the device being powered to the terminals marked [- Output1 +] through [- Output12 +] carefully observing polarity.

- For Fail-Safe operation slide output control logic DIP switch marked [Output] for corresponding input into the OFF position (Fig. 3, on right).
- For Fail-Secure operation slide output control logic DIP switch marked [Output] for corresponding input into the ON position (Fig. 3, on right).

7. Turn main power on after all devices are connected.

**Important: Inputs/Outputs and their switches are grouped (Fig. 3, pg. 4).**

#### Input Trigger Options:

**Note:** If Fire Alarm disconnect is not used, connect a 10K Ohm resistor to terminals marked [GND and EOL], plus connect a jumper to terminals marked [GND, RST].

#### Normally Open (NO) Input:

Slide input control logic DIP switch marked [NO-NC] for corresponding input into the OFF position (Fig. 4, on right). Connect your wires to terminals marked [+ INP1 -] to [+ INP12 -].

#### Normally Closed (NC) Input:

Slide input control logic DIP switch marked [NO-NC] for corresponding input into the ON position (Fig. 4, on right). Connect your wires to terminals marked [+ INP1 -] to [+ INP12 -].

#### Open Collector Sink Input:

Connect the open collector sink input to the terminal marked [+ INP1 -] to [+ INP12 -].

#### Wet (Voltage) Input Configuration:

Carefully observing polarity, connect the voltage input trigger wires and the supplied 10K resistor to terminals marked [+ INP1 -] to [+ INP12 -].

If applying voltage to trigger input - set the corresponding INP Logic switch to the "OFF" position  
If removing voltage to trigger input - set the corresponding INP Logic switch to the "ON" position.

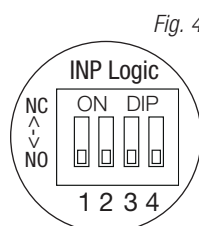
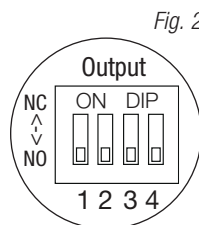
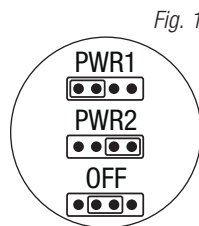
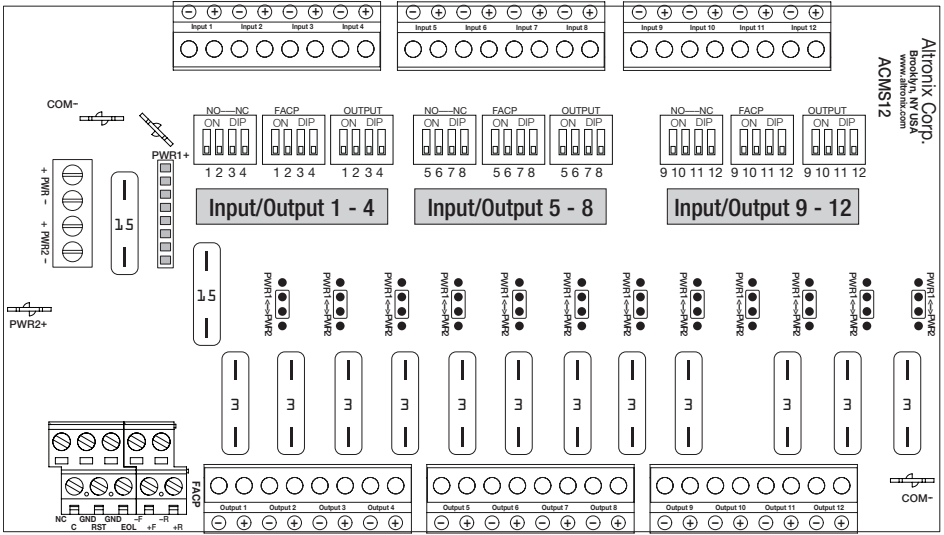

Fig. 3 - ACMS12



Altronix Corp.  
 Brooklyn, NY, USA  
 ACMS12

9. **Fire Alarm Interface Options:**

A normally closed [NC], normally open [NO] input or polarity reversal input from FACP signaling circuit will trigger selected outputs.

To enable FACP Disconnect for an output slide output control logic

DIP switch marked [FACP] for corresponding output ON (Fig. 5, on right).

To disable FACP Disconnect for an output slide output control logic

DIP switch marked [FACP] for corresponding output OFF (Fig. 5, on right).

**Normally Open Input:**

Wire your FACP relay and 10K resistor in parallel on terminals marked [GND] and [EOL].

**Normally Closed Input:**

Wire your FACP relay and 10K resistor in series on terminals marked [GND] and [EOL].

**FACP Signaling Circuit input trigger:**

Connect the positive (+) and negative (-) from the FACP signaling circuit output to the terminals marked [+ FACP -]. Connect the FACP EOL to the terminals marked [+ RET -] (polarity is referenced in an alarm condition).

**Non-Latching Fire Alarm Disconnect:**

Connect a jumper to the terminals marked [GND, RST].

**Latching Fire Alarm Disconnect:**

Connect a NO normally open reset switch to terminals marked [GND, RST].

10. **FACP Dry NC output:**

Connect desired device to be triggered by the unit's dry contact output to the terminals marked [NC] and [C]. When [EOL JMP] is kept intact, the output is of 0 Ohm resistance in a normal condition.

When [EOL JMP] is clipped, a 10k resistance will be passed to next device when in a normal condition.

Fig. 5

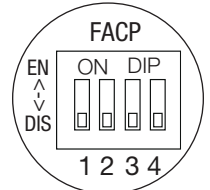

## Daisy Chaining Two (2) ACMS12(CB) Dual Output Access Power Controllers:

Use 18 AWG or larger UL Listed wire equipped with 1/4" UL Recognized quick connect terminals rated for proper voltage/current for all jumper connections.

1. Connect first ACMS12(CB) board's spade lug marked [PWR1 +] to the second ACMS12(CB) board's terminal marked [+ PWR1].
2. Connect first ACMS12(CB) board's spade lug marked [COM -] to the second ACMS12(CB) board's terminal marked [PWR1 -].
3. Connect first ACMS12(CB) board's spade lug marked [PWR2 +] to the second ACMS12(CB) board's terminal marked [+ PWR2].

Fig. 5

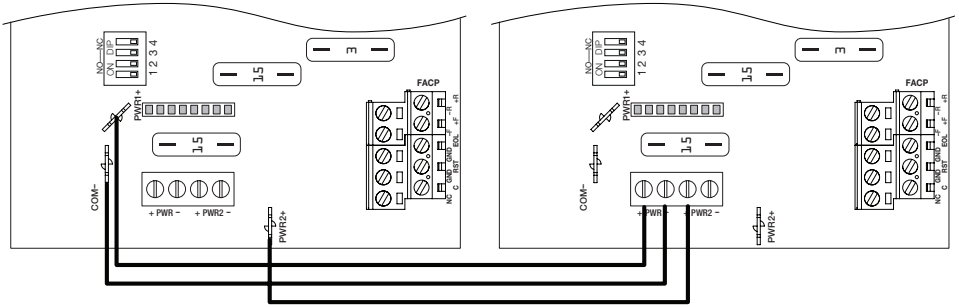

### LED Diagnostics:

#### ACMS12 and ACMS12CB Access Power Controller

LED	ON	OFF
LED 1- LED 12 (Red)	Output relay(s) de-energized.	Output relay(s) energized.
FACP	FACP input triggered (alarm condition).	FACP normal (non-alarm condition).
Green Output 1-12	12VDC	—
Red Output 1-12	24VDC	—

### Terminal Identification Table:

#### ACMS12 and ACMS12CB Access Power Controller

Terminal Legend	Function/Description
+ PWR1 -	12 or 24 VDC from eFlow power supply.
+ PWR2 -	12 or 24 VDC from eFlow power supply or either 5 or 12 VDC from VR6 regulator.
+ INP1 - through + INP12 -	Twelve (12) independently controlled Normally Open (NO), Normally Closed (NC), Open Collector Sink or Wet Input Triggers.
C, NC	FACP Dry NC output rated 1A/28VDC @ 0.6 Power Factor. Class 2 power-limited. With EOL JUMP intact, will provide 10k resistance in a normal state.
GND, RST	FACP interface latching or non-latching. NO dry input. Class 2 power-limited. To be shorted for non-latching FACP interface or Latch FACP reset.
GND, EOL	EOL Supervised FACP Input terminals for polarity reversal FACP function. Class 2 power-limited.
- F, + F, - R, + R	FACP Signaling Circuit Input and Return terminals. Class 2 power-limited.
- Output 1 + through - Output 12 +	Twelve (12) selectable independently controlled outputs (Fail-Safe or Fail-Secure).

# Typical Application Diagram:

Fig. 6

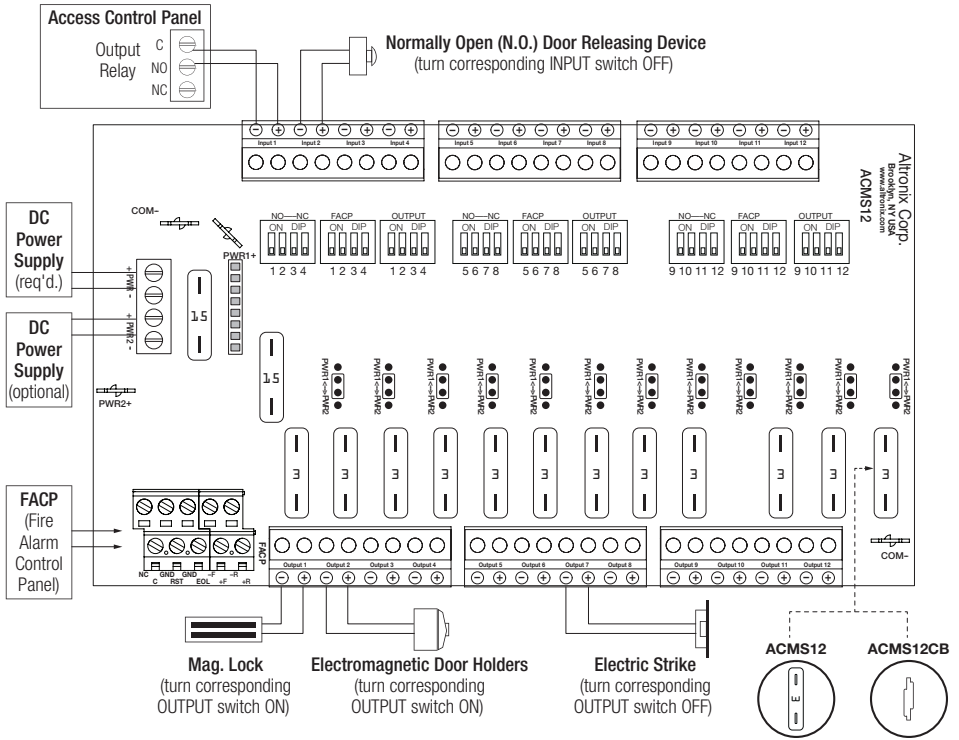

## Input/Output Voltage Ratings

Input Voltage and Source	Output Voltage Rating
5VDC (From VR6 regulator)	5VDC
12V (from VR6 regulator)	12VDC
12VDC (from external power supply)	11.7-12VDC
24VDC (from external power supply)	23.7-24VDC

### Maximum Output of Altronix Power Supplies:

UL Listed or Recognized Power Supply	Output Voltage Setting	Max. Output Current
eFlow4NB	12VDC or 24VDC	4A
eFlow6NB	12VDC or 24VDC	6A
eFlow102NB	12VDC	10A
eFlow104NB	24VDC	10A
VR6	5VDC or 12VDC	6A

# VR6 - Voltage Regulator

## Overview:

VR6 voltage regulator converts a 24VDC input into a regulated 5VDC or 12VDC output. It is specifically designed to work with ACMS12(CB) by allowing to mount the Access Power Controller directly on top of VR6 to save enclosure space and simplify connections. Refer to VR6 Installation Guide Rev. 050517.

## Specifications:

### Power Input / Output:

- Input: 24VDC @ 1.75A – Output: 5VDC @ 6A.
- Input: 24VDC @ 3.5A – Output: 12VDC @ 6A.

### Output:

- 5VDC or 12VDC regulated output.
- Output rating 6A max.
- Surge suppression.

### LED Indicators:

- Input and output LEDs.

### Electrical:

- Operating temperature: 0°C to 49°C ambient.
- Humidity: 20 to 93%, non-condensing.

### Mechanical:

- Product weight (approx.): 0.4 lb. (0.18 kg).
- Shipping weight (approx.): 0.5 lb. (0.23 kg).

## Connecting ACMS12(CB) to VR6:

1. Fasten male/female spacers (provided) to pems that match the hole pattern for VR6 in the desired location/enclosure. Use metal spacer for the mounting hole with star pattern (Fig. 7a, pg. 8).
2. Plug-in male 8-pin connector to female 8-pin receptacle on VR6 board (Fig. 7, pg. 8).
3. Fasten female/female spacers to male/female spacers (Fig. 7, pg. 8).  
Use metal spacers over mounting hole with star pattern (Fig. 7a, pg. 8).
4. Align 8-pin male connector with female receptacle of ACMS12/ACMS12CB, then attach board to spacers utilizing provided 5/16" pan head screws (Fig. 7, pg. 8).
5. Connect 24VDC power supply to terminal marked [+ PWR1 -] of ACMS12/ACMS12CB (Fig. 8, pg. 7).
6. Select output voltage 5VDC or 12VDC using switch [S1] on VR6.
7. Complete steps 4-10 (pgs. 3-4).

Fig. 7

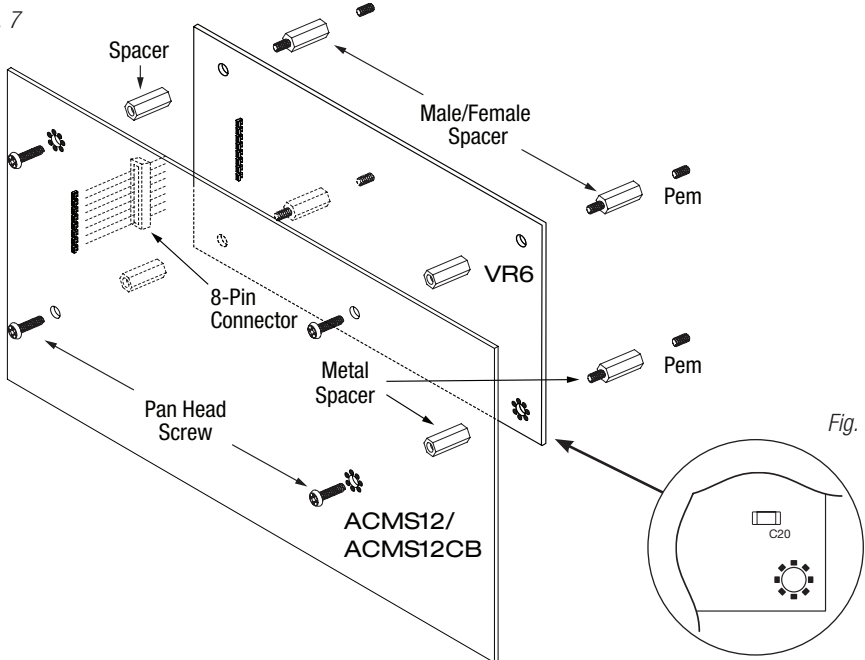

Fig. 7a



## Hook-Up Diagrams:

Fig. 8 - Daisy-chaining one or more ACMS12 units.  
EOL Jumper [EOL JMP] should be installed in the EOL position. **Non-Latching.**

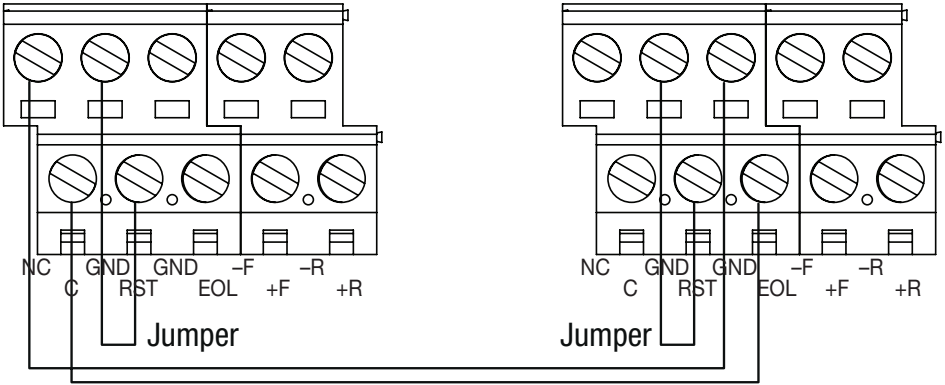

Fig. 9 - Daisy-chaining one or more ACMS12 units.  
EOL Jumper [EOL JMP] should be installed in the EOL position. **Latching Single Reset.**

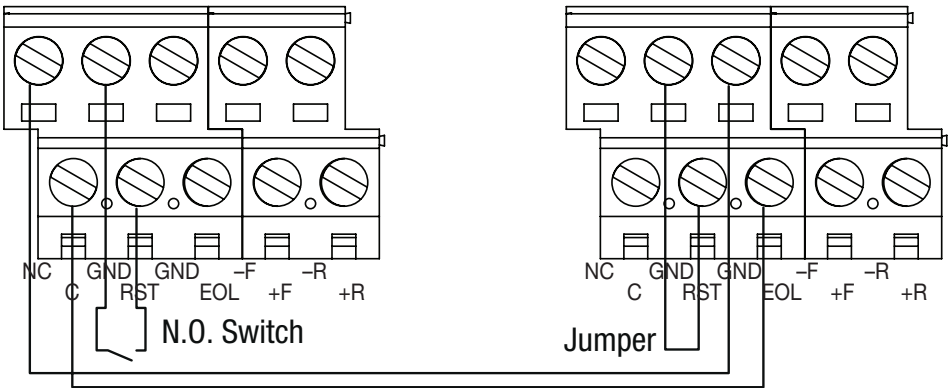
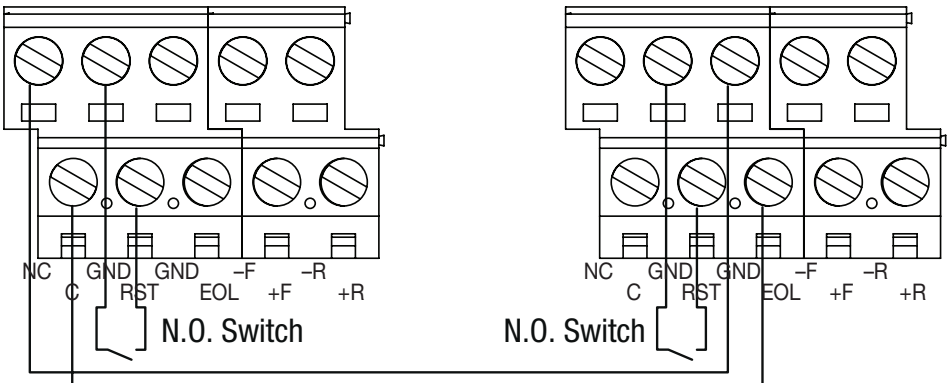
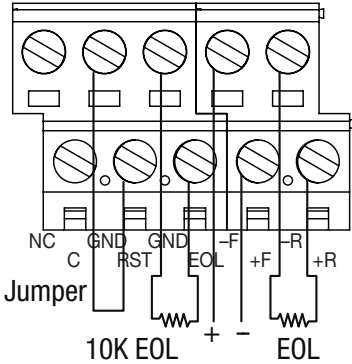

Fig. 10 - Daisy chaining one or more ACMS12 units.  
EOL Jumper [EOL JMP] should be installed in the EOL position. **Latching Individual Reset.**



## Hook-Up Diagrams:

*Fig. 10 -* Polarity reversal input from FACP signaling circuit output (polarity is referenced in alarm condition).  
**Non-Latching.**



*Fig. 11 -* Polarity reversal input from FACP signaling circuit output (polarity is referenced in alarm condition).  
**Latching.**

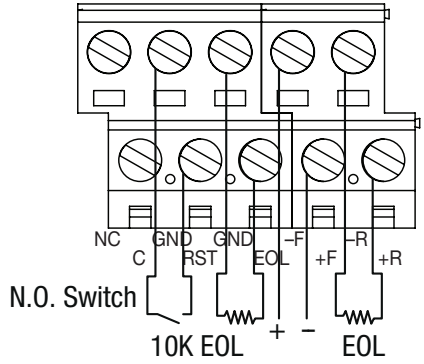

*Fig. 12 -* Normally Closed trigger input  
**(Non-Latching).**

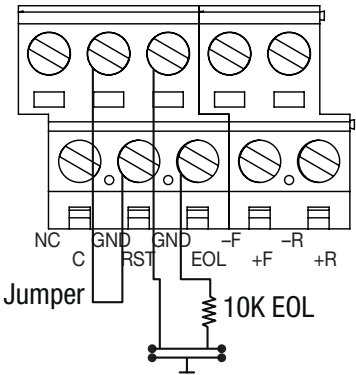

*Fig. 13 -* Normally Closed trigger input  
**(Latching).**

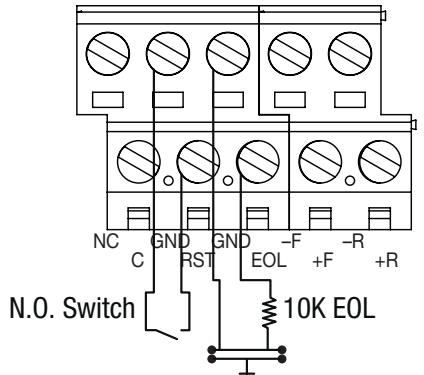

*Fig. 14 -* Normally Open trigger input  
**(Non-Latching).**

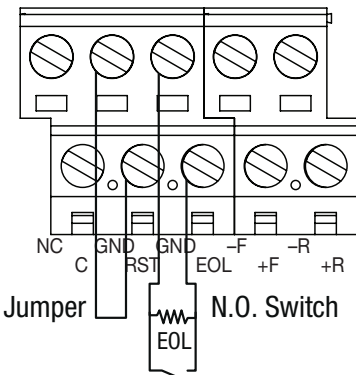

*Fig. 15 -* Normally Open trigger input  
**(Latching).**

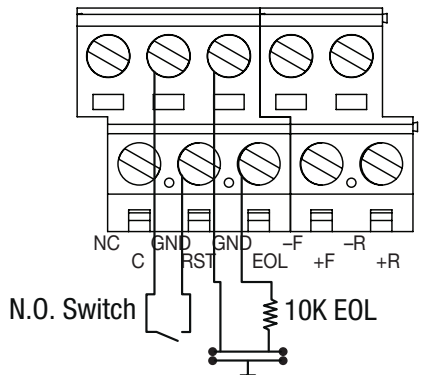

## Notes:

## Notes:

Altronix is not responsible for any typographical errors.

140 58th Street, Brooklyn, New York 11220 USA | phone: 718-567-8181 | fax: 718-567-9056  
website: [www.altronix.com](http://www.altronix.com) | e-mail: [info@altronix.com](mailto:info@altronix.com) | Lifetime Warranty  
IIACMS12/ACMS12CB F16V

