



Cisco Nexus 9348D-GX2A NX-OS Mode Switch Hardware Installation Guide

First Published: 2022-07-04

Americas Headquarters

Cisco Systems, Inc.
170 West Tasman Drive
San Jose, CA 95134-1706
USA
<http://www.cisco.com>
Tel: 408 526-4000
800 553-NETS (6387)
Fax: 408 527-0883

THE SPECIFICATIONS AND INFORMATION REGARDING THE PRODUCTS REFERENCED IN THIS DOCUMENTATION ARE SUBJECT TO CHANGE WITHOUT NOTICE. EXCEPT AS MAY OTHERWISE BE AGREED BY CISCO IN WRITING, ALL STATEMENTS, INFORMATION, AND RECOMMENDATIONS IN THIS DOCUMENTATION ARE PRESENTED WITHOUT WARRANTY OF ANY KIND, EXPRESS OR IMPLIED.

The Cisco End User License Agreement and any supplemental license terms govern your use of any Cisco software, including this product documentation, and are located at: <http://www.cisco.com/go/softwareterms>. Cisco product warranty information is available at <http://www.cisco.com/go/warranty>. US Federal Communications Commission Notices are found here <http://www.cisco.com/c/en/us/products/us-fcc-notice.html>.

IN NO EVENT SHALL CISCO OR ITS SUPPLIERS BE LIABLE FOR ANY INDIRECT, SPECIAL, CONSEQUENTIAL, OR INCIDENTAL DAMAGES, INCLUDING, WITHOUT LIMITATION, LOST PROFITS OR LOSS OR DAMAGE TO DATA ARISING OUT OF THE USE OR INABILITY TO USE THIS MANUAL, EVEN IF CISCO OR ITS SUPPLIERS HAVE BEEN ADVISED OF THE POSSIBILITY OF SUCH DAMAGES.

Any products and features described herein as in development or available at a future date remain in varying stages of development and will be offered on a when-and if-available basis. Any such product or feature roadmaps are subject to change at the sole discretion of Cisco and Cisco will have no liability for delay in the delivery or failure to deliver any products or feature roadmap items that may be set forth in this document.

Any Internet Protocol (IP) addresses and phone numbers used in this document are not intended to be actual addresses and phone numbers. Any examples, command display output, network topology diagrams, and other figures included in the document are shown for illustrative purposes only. Any use of actual IP addresses or phone numbers in illustrative content is unintentional and coincidental.

The documentation set for this product strives to use bias-free language. For the purposes of this documentation set, bias-free is defined as language that does not imply discrimination based on age, disability, gender, racial identity, ethnic identity, sexual orientation, socioeconomic status, and intersectionality. Exceptions may be present in the documentation due to language that is hardcoded in the user interfaces of the product software, language used based on RFP documentation, or language that is used by a referenced third-party product.

Cisco and the Cisco logo are trademarks or registered trademarks of Cisco and/or its affiliates in the U.S. and other countries. To view a list of Cisco trademarks, go to this URL: [www.cisco.com go trademarks](http://www.cisco.com/go/trademarks). Third-party trademarks mentioned are the property of their respective owners. The use of the word partner does not imply a partnership relationship between Cisco and any other company. (1721R)

© 2022 Cisco Systems, Inc. All rights reserved.



CONTENTS

CHAPTER 1

Overview 1

Overview 1

CHAPTER 2

Preparing the Site 5

Temperature Requirements 5

Humidity Requirements 5

Altitude Requirements 5

Dust and Particulate Requirements 6

Minimizing Electromagnetic and Radio Frequency Interference 6

Shock and Vibration Requirements 7

Grounding Requirements 7

Planning for Power Requirements 7

Airflow Requirements 8

Rack and Cabinet Requirements 9

Clearance Requirements 10

CHAPTER 3

Installing the Chassis 11

Installation Options with Rack-Mount Kits 11

Install a Rack 11

Unpacking and Inspecting a New Switch 12

Planning How to Position the Chassis in the Rack 13

Installing the Chassis in a Four-Post Rack 13

Installing the Switch using the NXK-ACC-KIT2-2RU Rack-Mount Kit 14

Grounding the Chassis 20

Starting the Switch 22

CHAPTER 4	Connecting the Switch to the Network	25
	Overview of Network Connections	25
	Connecting a Console to the Switch	26
	Creating the Initial Switch Configuration	27
	Setting Up the Management Interface	28
	Connecting Interface Ports to Other Devices	29

CHAPTER 5	Replacing Components	31
	Replacing a Fan Module During Operations	31
	Replacing a Power Supply Module	32
	Removing an AC Power Supply	32
	Installing an AC Power Supply	33

APPENDIX A	Rack Specifications	35
	Overview of Racks	35
	General Requirements for Cabinets and Racks	35
	Requirements Specific to Standard Open Racks	36
	Requirements Specific to Perforated Cabinets	36
	Cable Management Guidelines	36

APPENDIX B	System Specifications	37
	Environmental Specifications	37
	Switch Dimensions	37
	Switch and Module Weights and Quantities	38
	Transceiver and Cable Specifications	38
	Switch Power Input Requirements	38
	Power Specifications	38
	3200-W AC/HVDC Power Supply Specifications	39
	3200-W DC/HVDC Power Supply Specifications	39
	Power Cable Specifications	39
	Power Cables for NXA-PAC-3200W Power Supplies	40
	Regulatory Standards Compliance Specifications	40

APPENDIX C**LEDs 43**

Switch Chassis LEDs 43

Fan Module LEDs 44

Power Supply LEDs 44

APPENDIX D**Additional Kits 47**

Rack Mount Kit NXK-ACC-KIT2-2RU 47

Accessory Kit NXA-ACC-QDD-DC 48



CHAPTER 1

Overview

- [Overview, on page 1](#)

Overview

The Cisco Nexus 9348D-GX2A switch (N9K-C9348D-GX2A) is a 2-rack unit (RU), fixed-port switch designed for deployment in data centers.

This switch includes the following ports:

- 400-Gigabit QSFP-DD ports (48)
- 10-Gigabit SFP+ ports (2)
- Management ports (one RJ-45 port and one SFP port)
- Console port
- USB port



Note Dust covers (NXA-ACC-QDD-DC) are suggested for unused ports, to protect the connectors and help divert airflow for thermal dispensation.

This switch includes the following high power optics and MACsec:

- Up to 48 ports of MACsec with 24 ports of 20-W optics



Note For this switch, 24 ports of 20-W optics, and 48 ports of MACsec, can be supported either individually or together. And this 24 ports of 20-W optics can go in the following 24 ports only: 3, 6, 9, 12, 15, 18, 21, 24, 27, 30, 33, 36, 39, 42, 45, 48, 26, 29, 32, 35, 38, 41, and 47.

This switch includes the following user-replaceable components:

- Fan modules (four) with the following airflow choices:

- Port-side intake fan module with burgundy coloring (NXA-FAN-160CFM-PI)



Note If a fan fails, the other fans are automatically increased to 100% capacity to compensate. If two fans fail, then multi fan failure policy kicks in, the switch will issue a warning, and power down in 2 minutes.

- Power supply modules (two—One for operations and one for redundancy [1+1]) with the following choices:
 - 3200-W port-side intake AC/HVDC power supply with burgundy coloring (NXA-PAC-3200W-PI)
 - 3200-W port-side intake DC/HVDC power supply with burgundy coloring (NXA-PDC-3200W-PI)



Note Both power supplies are the same type. Do not mix AC, and DC, power supplies.



Note All fan modules and power supplies must use the same airflow direction.

The following figure shows the switch features on the port side of the chassis.

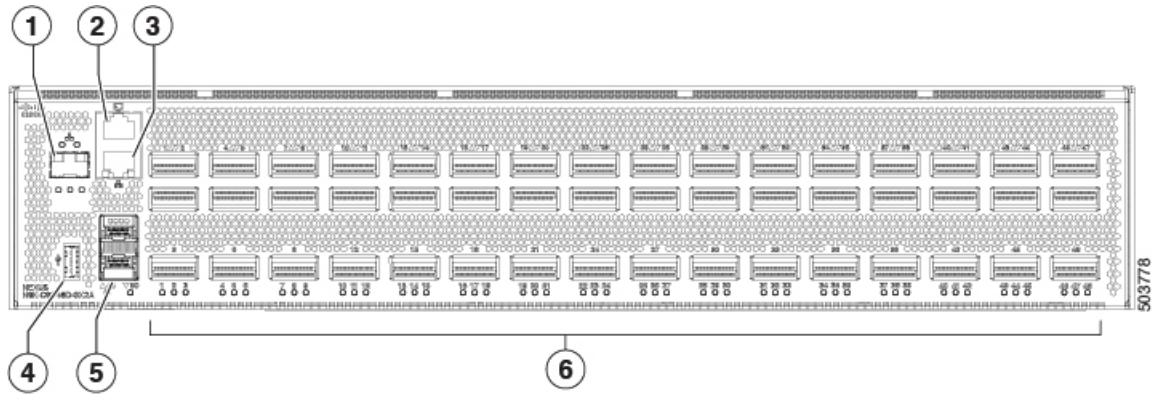

1	SFP optical management port (1)	4	USB port (1)
2	Console port (1)	5	10-Gigabit SFP+ ports (2)
3	RJ-45 copper management port (1)	6	400-Gigabit QSFP-DD ports (48)

To determine which transceivers, adapters, and cables are support this switch, see the [Cisco Transceiver Modules Compatibility Information](#) document.

The following figure shows the switch features on the power supply side of the chassis.

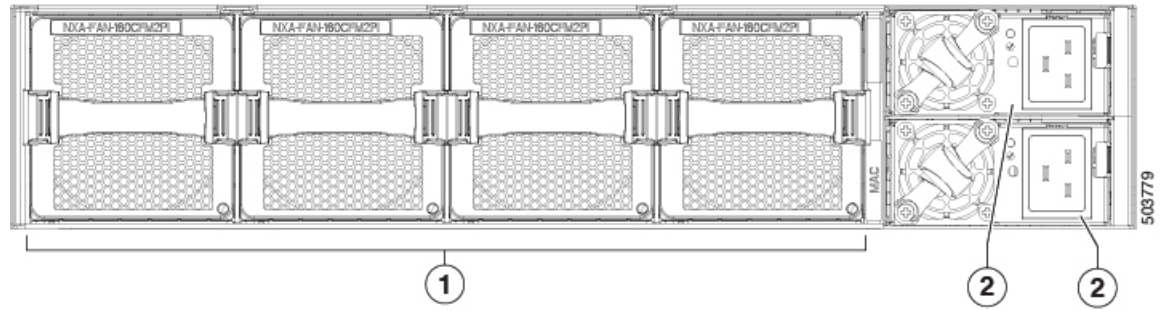

1	Fan modules (4) with slots numbered from 1 (left) to 4 (right)	2	Power supply modules (1 or 2) (AC power supplies shown) with slots numbered 1 (top) and 2 (bottom)
---	--	---	--

The following figure shows the side of the chassis.

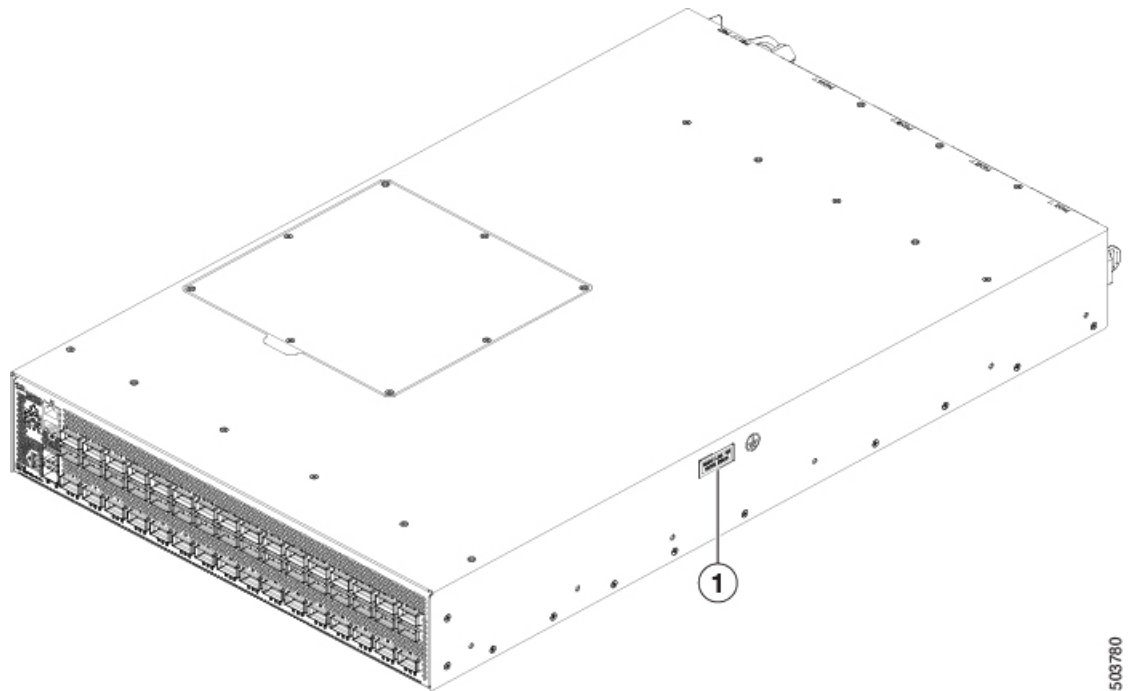

1	Grounding pad
---	---------------

The fan and power supply modules are field replaceable. You can replace one fan module or one power supply module during operations so long as the other modules are installed and operating. If you have only one power supply installed, you can install the replacement power supply in the open slot before removing the original power supply.



Note All fan and power supply modules must have the same direction of airflow. Otherwise, the switch can overheat and shut down. If you are installing a dual-direction power supply, that module automatically uses the same airflow direction as the other modules in the switch.

**Caution**

If the switch has port-side intake airflow (burgundy coloring for fan modules), you must locate the ports in the cold aisle. If the switch has port-side exhaust airflow (blue coloring for fan modules), you must locate the ports in the hot aisle. If you locate the air intake in a hot aisle, the switch can overheat and shut down.



CHAPTER 2

Preparing the Site

- [Temperature Requirements, on page 5](#)
- [Humidity Requirements, on page 5](#)
- [Altitude Requirements, on page 5](#)
- [Dust and Particulate Requirements, on page 6](#)
- [Minimizing Electromagnetic and Radio Frequency Interference, on page 6](#)
- [Shock and Vibration Requirements, on page 7](#)
- [Grounding Requirements, on page 7](#)
- [Planning for Power Requirements, on page 7](#)
- [Airflow Requirements, on page 8](#)
- [Rack and Cabinet Requirements, on page 9](#)
- [Clearance Requirements, on page 10](#)

Temperature Requirements

The switch requires an operating temperature of 32 to 104 degrees Fahrenheit (0 to 40 degrees Celsius). If the switch is not operating, the temperature must be between –40 to 158 degrees Fahrenheit (–40 to 70 degrees Celsius).

Humidity Requirements

Buildings in which the climate is controlled by air-conditioning in the warmer months and by heat during the colder months usually maintain an acceptable level of humidity for the switch equipment. However, if the switch is located in an unusually humid location, use a dehumidifier to maintain the humidity within an acceptable range.

Altitude Requirements

Altitude rating is based on power supply installed; see critical components list in the system CB report for altitude rating.

Dust and Particulate Requirements

Exhaust fans cool power supplies and system fans cool switches by drawing in air and exhausting air out through various openings in the chassis. However, fans also ingest dust and other particles, causing contaminant buildup in the switch and increased internal chassis temperature. Dust and particles can act as insulators and interfere with the mechanical components in the switch. A clean operating environment can greatly reduce the negative effects of dust and other particles.

In addition to keeping your environment free of dust and particles, follow these precautions to avoid contamination of your switch:

- Do not permit smoking near the switch.
- Do not permit food or drink near the switch.

Minimizing Electromagnetic and Radio Frequency Interference

Electromagnetic interference (EMI) and radio frequency interference (RFI) from the switch can adversely affect other devices, such as radio and television (TV) receivers. Radio frequencies that emanate from the switch can also interfere with cordless and low-power telephones. Conversely, RFI from high-power telephones can cause spurious characters to appear on the switch monitor.

RFI is defined as any EMI with a frequency above 10 kHz. This type of interference can travel from the switch to other devices through the power cable and power source or through the air as transmitted radio waves. The Federal Communications Commission (FCC) publishes specific regulations to limit the amount of EMI and RFI that are emitted by computing equipment. Each switch meets these FCC regulations.

To reduce the possibility of EMI and RFI, follow these guidelines:

- Cover all open expansion slots with a blank filler plate.
- Always use shielded cables with metal connector shells for attaching peripherals to the switch.

When wires are run for any significant distance in an electromagnetic field, interference can occur to the signals on the wires with the following implications:

- Bad wiring can result in radio interference emanating from the plant wiring.
- Strong EMI, especially when it is caused by lightning or radio transmitters, can destroy the signal drivers and receivers in the chassis and even create an electrical hazard by conducting power surges through lines into equipment.



Note To predict and prevent strong EMI, you need to consult experts in radio frequency interference (RFI).

The wiring is unlikely to emit radio interference if you use a twisted-pair cable with a good distribution of grounding conductors. If you exceed the recommended distances, use a high-quality twisted-pair cable with one ground conductor for each data signal when applicable.

**Caution**

If the wires exceed the recommended distances, or if wires pass between buildings, give special consideration to the effect of a lightning strike in your vicinity. The electromagnetic pulse that is caused by lightning or other high-energy phenomena can easily couple enough energy into unshielded conductors to destroy electronic switches. You will want to consult experts in electrical surge suppression and shielding if you had similar problems in the past.

Shock and Vibration Requirements

The switch has been shock- and vibration-tested for operating ranges, handling, and earthquake standards.

Grounding Requirements

The switch is sensitive to variations in voltage that is supplied by the power sources. Overvoltage, undervoltage, and transients (or spikes) can erase data from memory or cause components to fail. To protect against these types of problems, ensure that there is an earth-ground connection for the switch. You can connect the grounding pad on the switch either directly to the earth-ground connection or to a fully bonded and grounded rack.

When you properly install the chassis in a grounded rack, the switch is grounded because it has a metal-to-metal connection to the rack. Alternatively, you can ground the chassis by using a customer-supplied grounding cable that meets your local and national installation requirements. For U.S. installations, we recommend 6-AWG wire. Connect your grounding cable to the chassis with a grounding lug (provided in the switch accessory kit) and to the facility ground.

**Note**

You automatically ground AC power supplies when you connect them to AC power sources. For DC power supplies, you must connect a grounding wire when wiring the power supply to the DC power source.

**Note**

An electrical conducting path shall exist between the product chassis and the metal surface of the enclosure or rack in which it is mounted or to a grounding conductor. Electrical continuity shall be provided by using thread-forming type mounting screws that remove any paint or non-conductive coatings and establish a metal-to-metal contact. Any paint or other non-conductive coatings shall be removed on the surfaces between the mounting hardware and the enclosure or rack. The surfaces shall be cleaned and an antioxidant applied before installation.

Planning for Power Requirements

The switch includes two power supplies (1-to-1 redundancy with current sharing) in one of the following combinations:

- Two 3200-W AC/HVDC power supplies
- Two 3200-W DC/HVDC power supplies



Note For $n+1$ redundancy, you can use one or two power sources for the two power supplies. For $n+n$ redundancy, you must use two power sources and connect each power supply to a separate power source.



Note Some of the power supply modules have rating capabilities that exceed the switch requirements. When calculating your power requirements, use the switch requirements to determine the amount of power that is required for the power supplies.

To minimize the possibility of circuit failure, make sure that each power-source circuit that is used by the switch is dedicated to the switch.



Note For AC input application, please refer to the following statement:



Warning **Statement 1005**—Circuit Breaker when using AC power supplies

This product relies on the building's installation for short-circuit (overcurrent) protection. Ensure that the protective devices are rated not greater than 20A (North America), 16A (Europe), and 13A (UK).



Note For DC input application, please refer to the following statement:



Warning **Statement 1033**

Connect the unit only to DC power source that complies with the Safety Extra-Low Voltage (SELV) requirements in IEC 60950 based safety standards.



Note We recommend 8-AWG wire for DC installations in the U.S.

Airflow Requirements

The switch is positioned with its ports in either the front or the rear of the rack depending on your cabling and maintenance requirements.

To identify the airflow options for your switch, see the user-replaceable components in the *Overview* section of this document.

You must have fan and power supply modules that move the coolant air from the cold aisle to the hot aisle in one of the following ways:

- Port-side exhaust airflow—Cool air enters the chassis through the fan and power supply modules in the cold aisle and exhausts through the port end of the chassis in the hot aisle.
- Port-side intake airflow—Cool air enters the chassis through the port end in the cold aisle and exhausts through the fan and power supply modules in the hot aisle.

You can identify the airflow direction of each fan and power supply module by its coloring as follows:

- Blue coloring indicates port-side exhaust airflow.
- Burgundy coloring indicates port-side intake airflow.



Note To prevent the switch from overheating and shutting down, you must position the air intake for the switch in a cold aisle. The fan and power supply modules must have the same direction of airflow (even if their coloring is different). If you must change the airflow direction for the switch, you must shutdown the switch before changing the modules.

Rack and Cabinet Requirements

You can install the following types of racks or cabinets for your switch:

- Standard perforated cabinets
- Solid-walled cabinets with a roof fan tray (bottom-to-top cooling)
- Standard open four-post Telco racks

Work with your cabinet vendors to determine which of their cabinets meet the following requirements or see the Cisco Technical Assistance Center (TAC) for recommendations:

- Use a standard 19-inch (48.3-cm), four-post Electronic Industries Alliance (EIA) cabinet or rack with mounting rails that conform to English universal hole spacing per section 1 of the ANSI/EIA-310-D-1992 standard.
- The depth of a four-post rack must be 24 to 32 inches (61.0 to 81.3 cm) between the front and rear mounting rails (for proper mounting of the bottom-support brackets or other mounting hardware).

Also, you must have power receptacles that are located within reach of the power cords that are used with the switch.



Warning **Statement 1048**—Rack Stabilization

The rack stabilizing mechanism must be in place, or the rack must be bolted to the floor before installation or servicing. Failure to stabilize the rack can cause bodily injury.



CHAPTER 3

Installing the Chassis

- [Installation Options with Rack-Mount Kits, on page 11](#)
- [Install a Rack, on page 11](#)
- [Unpacking and Inspecting a New Switch, on page 12](#)
- [Planning How to Position the Chassis in the Rack, on page 13](#)
- [Installing the Chassis in a Four-Post Rack, on page 13](#)
- [Grounding the Chassis, on page 20](#)
- [Starting the Switch, on page 22](#)

Installation Options with Rack-Mount Kits

The rack-mount kit enables you to install the switch into racks of varying depths. You can position the switch with easy access to either the port connections or the fan and power supply modules.

You can install the switch using the following rack-mount options:

- Rack-mount kit (NXK-ACC-KIT2-2RU) which you can order from Cisco.
For four post racks.
- Rack-mount kit (N9K-C9300-RMK) which you can order from Cisco.
For four post racks.

The rack or cabinet that you use must meet the requirements listed the in [General Requirements for Cabinets and Racks, on page 35](#) section.



Note You are responsible for verifying that your rack and rack-mount hardware comply with the guidelines that are described in this doc.

Install a Rack

Before you install the switch, you must install a standard four-post, 19-inch EIA data center rack (or a cabinet that contains such a rack) that meets the requirements listed in [Overview of Racks, on page 35](#).

Step 1 Bolt the rack to the concrete subfloor before moving the chassis onto it.

Warning Statement 1048—Rack Stabilization

The rack stabilizing mechanism must be in place, or the rack must be bolted to the floor before installation or servicing. Failure to stabilize the rack can cause bodily injury.

Step 2 If the rack has bonded construction, connect it to the earth ground. This action enables you to easily ground the switch and its components and to ground your electrostatic discharge (ESD) wrist strap to prevent damaging discharges when you handle ungrounded components before installing them.

Step 3 Include one or two power sources at the rack. For AC power, provide a power receptacle. For DC power, provide a circuit breaker with terminals for connecting power cables.

Warning Statement 1018—Supply Circuit

To reduce risk of electric shock and fire, take care when connecting units to the supply circuit so that wiring is not overloaded.

Note If you are not using power redundancy or are using $n+1$ redundancy, you need only one power source. If you are using $n+n$ redundancy, you need two power sources.

Unpacking and Inspecting a New Switch

Before you install a new chassis, you need to unpack and inspect it to be sure that you have all the items that you ordered and verify that the switch was not damaged during shipment. If anything is damaged or missing, contact your customer representative immediately.



Caution When you handle the chassis or its components, you must follow ESD protocol at all times to prevent ESD damage. This protocol includes but is not limited to wearing an ESD wrist strap that you connect to the earth ground.



Tip Do not discard the shipping container when you unpack the switch. Flatten the shipping cartons and store them. If you need to move or ship the system in the future, you will need this container.

Step 1 Compare the shipment to the equipment list that is provided by your customer service representative and verify that you have received all of the ordered items.

The shipment should include the following:

- Switch chassis, which includes the following installed components:
 - Two power supplies (any combination of the following with the airflow direction being the same as for the fan modules):

- fan modules (all fan and power supply modules must have the same airflow direction)
- Switch accessory kit

Step 2 Check the contents of the box for damage.

Step 3 If you notice any discrepancies or damage, send the following information to your customer service representative by email:

- Invoice number of the shipper (see the packing slip)
- Model and serial number of the missing or damaged unit
- Description of the problem and how it affects the installation

Planning How to Position the Chassis in the Rack

The switch is designed so that you can have coolant air flow through the switch in one of the two following directions:

- Enter the port side and exhaust out the power supply side (port-side intake airflow)
- Enter the power supply side and exhaust out the port side (port-side exhaust airflow)

For port-side intake airflow, the switch must have port-side intake fan and AC power supply modules with one or more of the following colorings:

- Burgundy coloring on fan modules and AC power supplies

For port-side exhaust airflow, the switch must have port-side exhaust fan and AC power supply modules with one or more of the following colorings:

- Blue coloring on fan modules and AC power supplies

You can plan the positioning of the switch so that its ports are located close to ports on connected devices or so that the fan and power supply modules are conveniently located in a maintenance aisle, and then order the modules that move coolant air in the appropriate direction from the cold aisle to the hot aisle.



Note All fan and power supply modules in the same switch must operate with the same direction of airflow and the air intake portion of the switch must be located in a cold aisle.

Installing the Chassis in a Four-Post Rack

Before you install the chassis, be sure that the rack is fully secured to the data center floor.

Installing the Switch using the NXK-ACC-KIT2-2RU Rack-Mount Kit

To install the switch, you must attach inner rails to the chassis, attach the outer rails to the rack, slide the switch onto the outer rails, and secure the switch to the rack with the retainer screws. Typically, the front of the rack is the side easiest to access for maintenance.

Before you begin

- You have inspected the switch shipment to ensure that you have everything ordered.
- Make sure that the switch rack-mount kit includes the following parts:
 - Rack-mount inner rails (2)
 - Rack-mount outer rails (2)
 - Flat head screws (12)
- The rack is installed and secured to its location.

Step 1 Install the two inner rails to the sides of the chassis using flat-head screws, as shown in the following illustration:

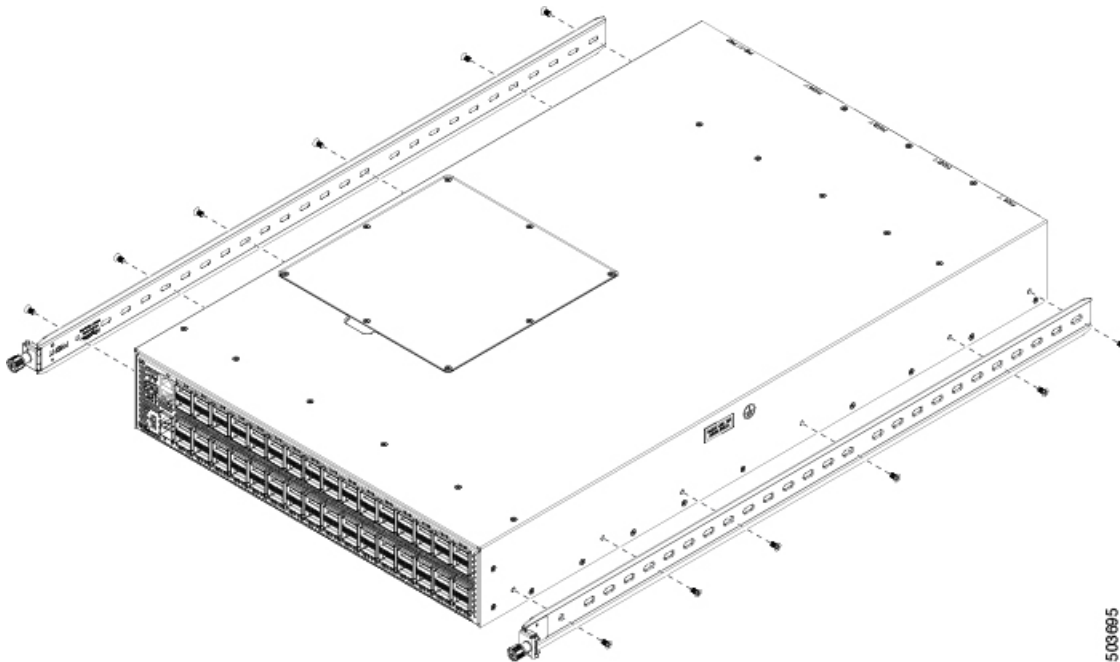

500695

Step 2 Install the two outer rails to the front posts of the rack by aligning the rails to the post holes, as shown in the following illustration:

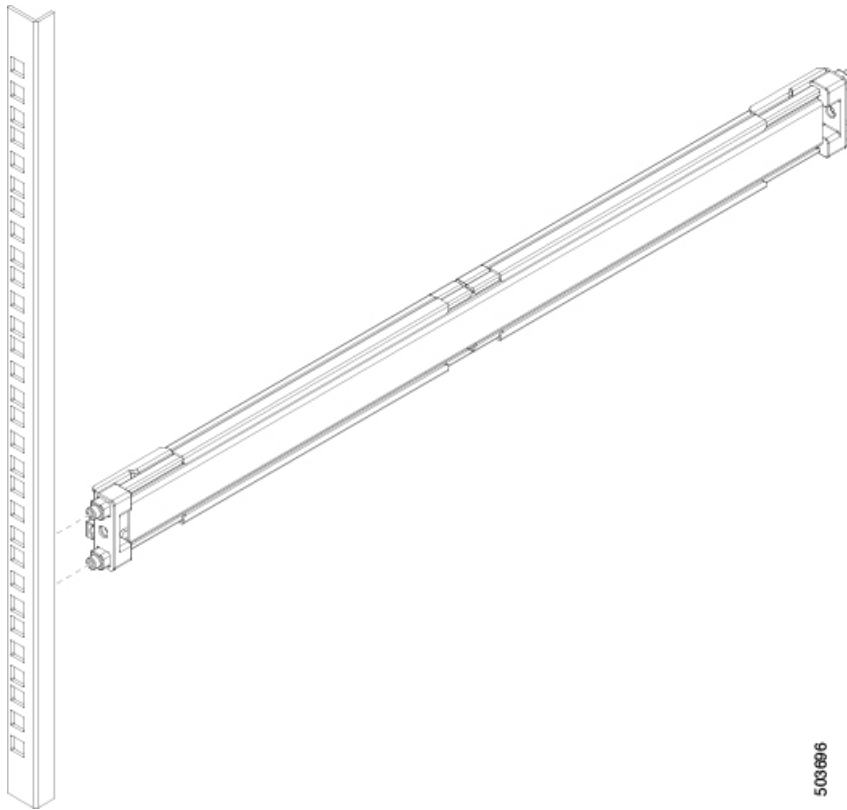

Step 3 Fasten the two outer rails to the front posts of the rack by pushing the latch into place, as shown in the following illustration:

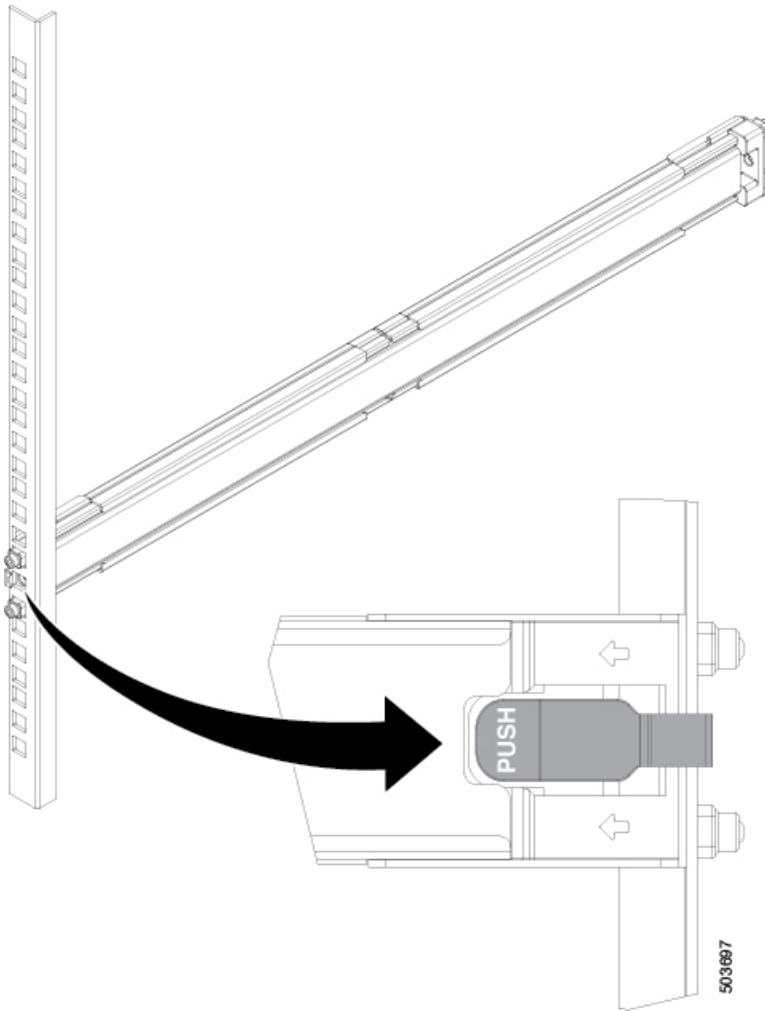

Step 4 Install the two outer rails to the back posts of the rack by extending them into place, as shown in the following illustration:

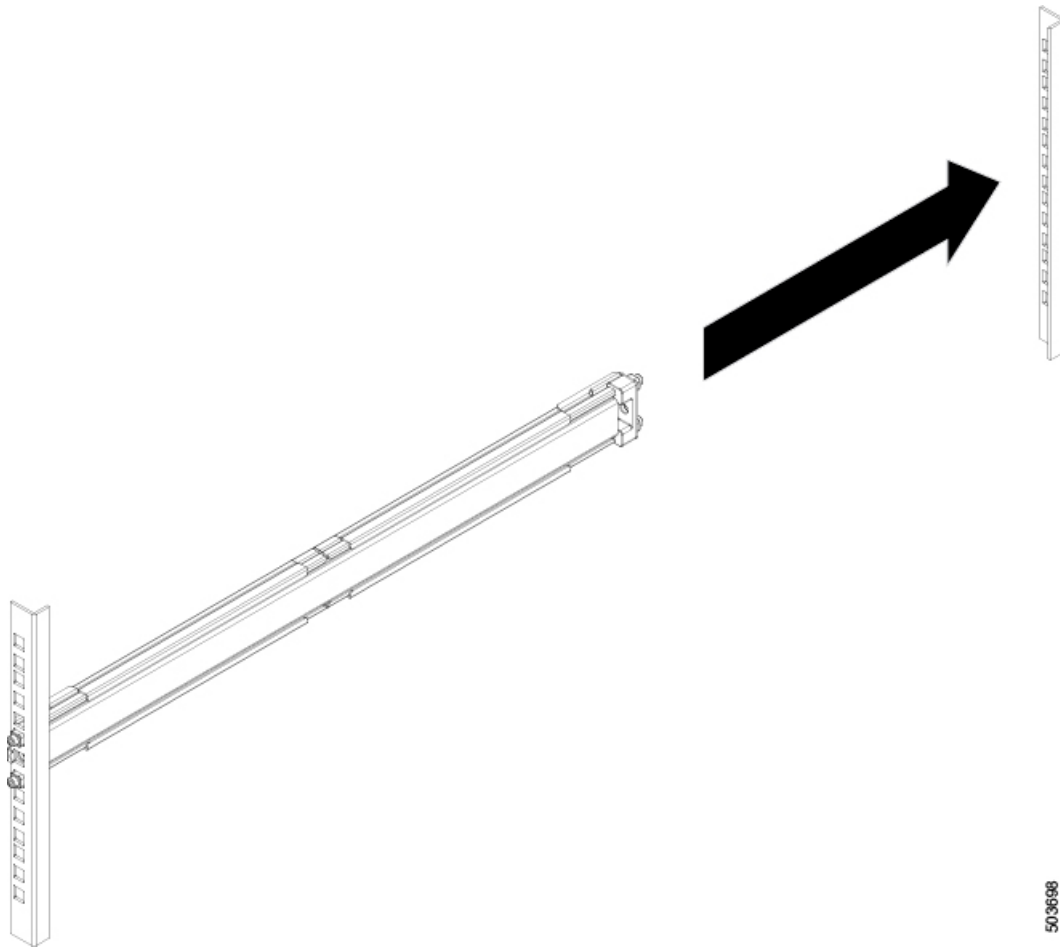

Step 5 Fasten the two outer rails to the back posts of the rack by pushing the latch into place, as shown in the following illustration:

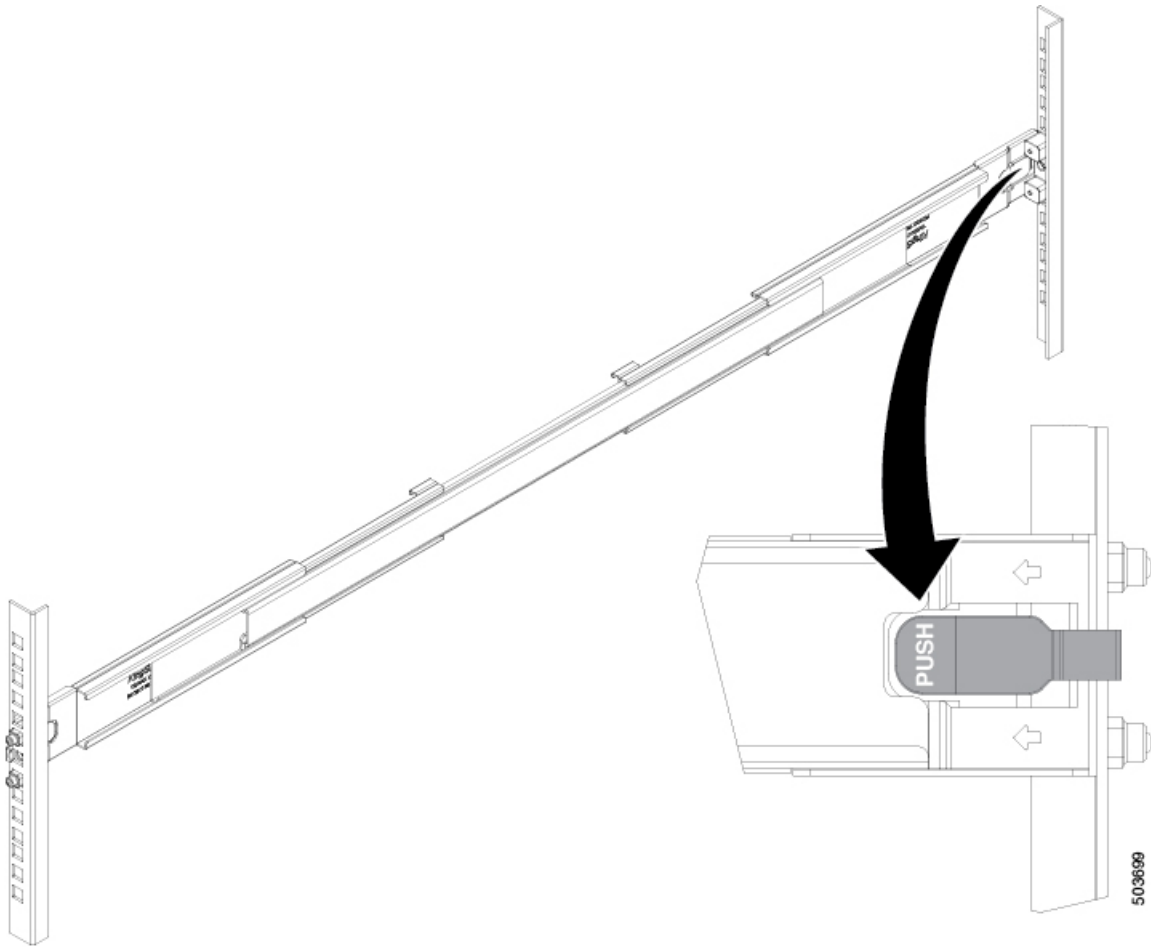

- Step 6** If installing from the front of the rack, slide the chassis into the rack by aligning the inner rails into the outer rails, and sliding the chassis back until the front panel is flush with the front of the rack. Then secure the retainer screws on the inner rails into the rack, as shown in the following illustration:

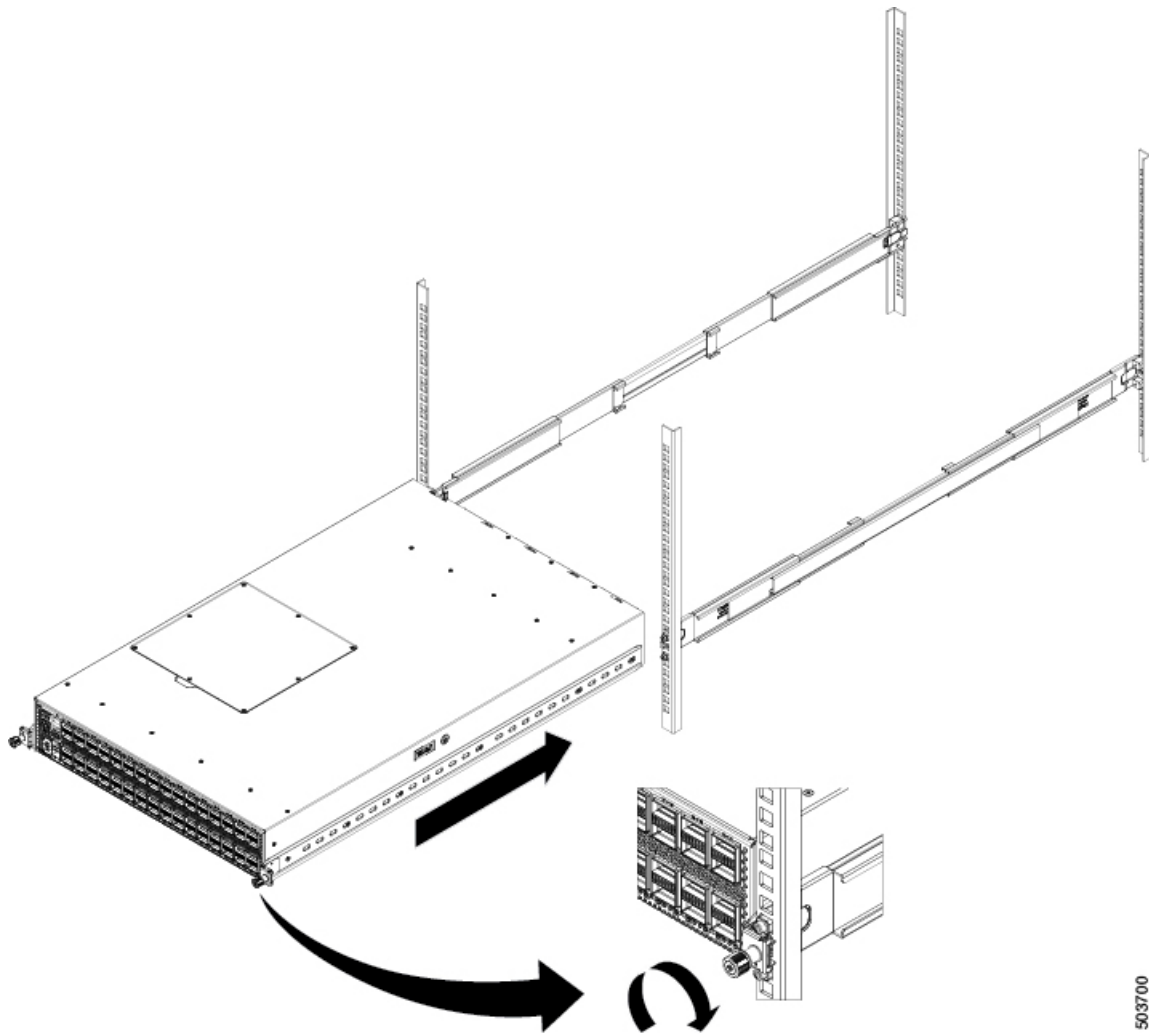
**Step 7**

If installing from the back of the rack, slide the chassis into the rack by aligning the inner rails into the outer rails, and sliding the chassis forward until the front panel is flush with the front of the rack. Then slide the retainer screws out to align with the rack and then secure the thumb-screws on the inner rails into the rack, as shown in the following illustration:

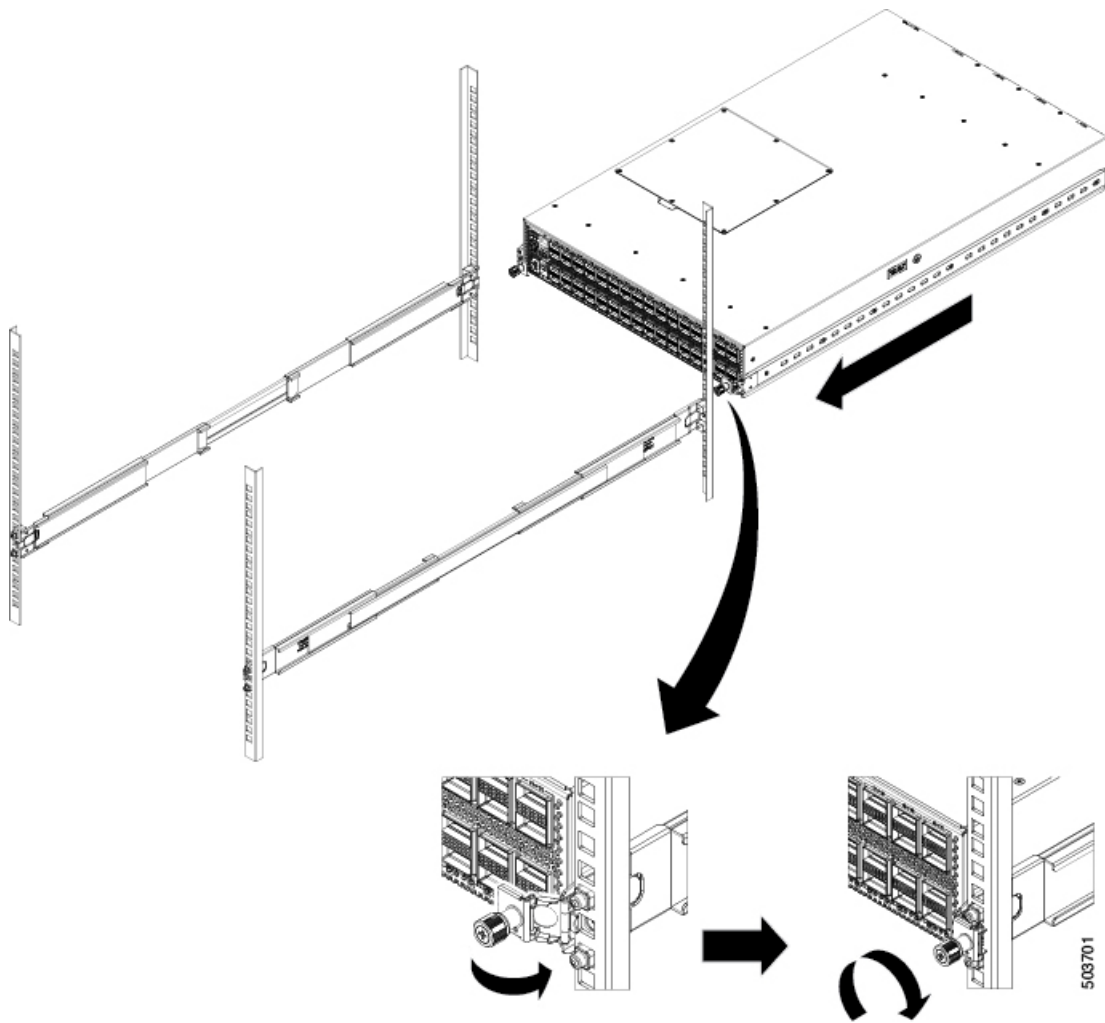

Grounding the Chassis

The switch chassis is automatically grounded when you properly install the switch in a grounded rack with metal-to-metal connections between the switch and rack.



Note An electrical conducting path shall exist between the product chassis and the metal surface of the enclosure or rack in which it is mounted or to a grounding conductor. Electrical continuity shall be provided by using thread-forming type mounting screws that remove any paint or non-conductive coatings and establish a metal-to-metal contact. Any paint or other non-conductive coatings shall be removed on the surfaces between the mounting hardware and the enclosure or rack. The surfaces shall be cleaned and an antioxidant applied before installation.

You can also ground the chassis, which is required if the rack is not grounded, by attaching a customer-supplied grounding cable. Attach the cable to the chassis grounding pad and the facility ground.



Warning Statement 1024—Ground Conductor

This equipment must be grounded. To reduce the risk of electric shock, never defeat the ground conductor or operate the equipment in the absence of a suitably installed ground conductor. Contact the appropriate electrical inspection authority or an electrician if you are uncertain that suitable grounding is available.



Warning Statement 1046—Installing or Replacing the Unit

To reduce risk of electric shock, when installing or replacing the unit, the ground connection must always be made first and disconnected last.

Before you begin

Before you can ground the chassis, you must have a connection to the earth ground for the data center building.

Step 1 Use a wire-stripping tool to remove approximately 0.75 inch (19 mm) of the covering from the end of the grounding wire. We recommend 6-AWG wire for the U.S. installations.

Step 2 Insert the stripped end of the grounding wire into the open end of the grounding lug. Use a crimping tool to crimp the lug to the wire, see the following figure. Verify that the ground wire is securely attached to the grounding lug by attempting to pull the wire out of the crimped lug.

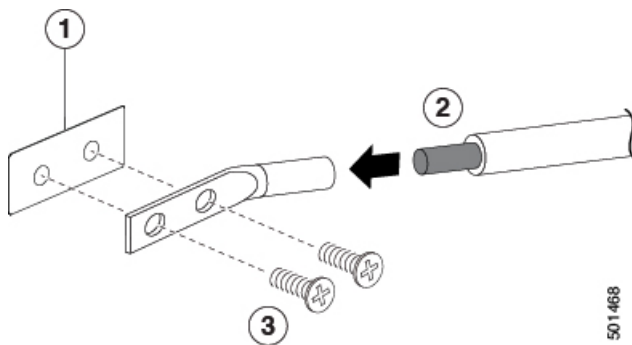

1	Chassis grounding pad	3	2 M4 screws are used to secure the grounding lug to the chassis
2	Grounding cable, with 0.75 in. (19 mm) of insulation that is stripped from one end, which is inserted into the grounding lug and crimped in place		

Step 3 Secure the grounding lug to the chassis grounding pad with two M4 screws, see the previous figure. Tighten the screws to 11 to 15 in-lb (1.24 to 1.69 N·m) of torque.

Step 4 Prepare the other end of the grounding wire and connect it to the facility ground.

Starting the Switch

You start the switch by connecting it to its dedicated power source. If you need $n+1$ redundancy, you must connect each of the power supplies to one or two power sources. If you need $n+n$ redundancy, you must connect each power supply in a switch to a different power source.



Note This equipment is designed to boot up in less than 30 minutes, dependent on its neighboring devices being fully up and running.

Before you begin

- The switch must be installed and secured to a rack or cabinet.
- The switch must be adequately grounded.
- The rack must be close enough to the dedicated power source so that you can connect the switch to the power source by using a designated power cables.
- You have the designated power cables for the power supplies that you are connecting to the dedicated power sources.



Note Depending on the outlet receptacle on your AC power distribution unit, you might need an optional jumper power cord to connect the switch to your outlet receptacle.

- The switch is not connected to the network (this includes any management or interface connections).
- The fan and power supply modules are fully secured in their chassis slots.

Step 1 For each AC power supply, do the following:

- a) Using the recommended AC power cable for your country or region, connect one end to the AC power supply.
- b) Connect the other end of the power cable to the AC power source.

Step 2 For each HVAC/HVDC power supply, connect it to a power source as follows:

- a) Using the recommended high voltage power cable for your country or region, connect the Anderson Power Saf-D-Grid connector on the power cable to the power receptacle on the power supply. Make sure that the connector clicks when fully pushed into the receptacle.
- b) Connect the other end of the power cable to a power source.
 - When connecting to an HVAC power source, insert the C14 or LS-25 plug in a receptacle for the HVAC power source.
 - When connecting to an HVDC power source, do the following:
 1. Verify that the power is turned off at a circuit breaker for the power source terminals.
 2. Remove the nuts from each of the terminal posts for the power supply.

3. Place the power cable negative-wire terminal ring on the negative terminal for the power source and secure them with a terminal nut.
4. Place the power cable positive-wire terminal ring on the positive terminal for the power source and secure them with a terminal nut.
5. Place the power cable ground-wire terminal ring on the ground terminal for the power source and secure them with a terminal nut.
6. If there is a safety cover for the power source terminals, place and secure it over the terminals to avoid an electrical shock hazard.
7. Turn on the power at the power source circuit breaker.

Step 3 For each DC power supply, do the following:

- a) Turn off the circuit breaker for the power source to avoid an electrical shock hazard.
- b) Verify that the power cable wires from the power source are connected to a connector block.
- c) Insert the connector block into the receptacle on the power supply. Make sure that the connector block clicks when fully inserted in the receptacle and does not pull out.
- d) If there is a safety cover for the terminals, place and secure it over the terminals to avoid an electrical shock hazard.
- e) Turn on the power at the circuit breaker for the DC power source.

Step 4 Verify that the power supply LED is on and green.

Step 5 Listen for the fans; they should begin operating when the power supply is powered.

Step 6 After the switch boots, verify that the following LEDs are lit:

- On the fan modules, the Status (STA or STS) LED is green.
If a fan module Status LED is not green, try reinstalling the fan module.
- After initialization, the switch chassis Status (labeled as STA or STS) LED is green.

Step 7 Verify that the system software has booted and the switch has initialized without error messages.

A setup utility automatically launches the first time that you access the switch and guides you through the basic configuration. For instructions on how to configure the switch and check module connectivity, see the appropriate Cisco Nexus 9000 Series configuration guide.



CHAPTER 4

Connecting the Switch to the Network

- [Overview of Network Connections, on page 25](#)
- [Connecting a Console to the Switch, on page 26](#)
- [Creating the Initial Switch Configuration, on page 27](#)
- [Setting Up the Management Interface, on page 28](#)
- [Connecting Interface Ports to Other Devices, on page 29](#)

Overview of Network Connections

After you install the switch in a rack and power it up, you are ready to make the following network connections:

- **Console connection**—This is a direct local management connection that you use to initially configure the switch. You must make this connection first to initially configure the switch and determine its IP address, which is needed for the other connections.
- **Management connection**—After you complete the initial configuration using a console, you can make this connection to manage all future switch configurations.
- **Uplink and downlink interface connections**—These are connections to hosts and servers in the network.

Each of these connection types is explained in one of the sections that follow.



Note When running cables in overhead or subfloor cable trays, we strongly recommend that you locate power cables and other potential noise sources as far away as practical from network cabling that terminates on Cisco equipment. In situations where long parallel cable runs cannot be separated by at least 3.3 feet (1 meter), we recommend that you shield any potential noise sources by housing them in a grounded metallic conduit.



Note When using SFP+ or SFP transceivers in a QSFP+ or QSFP28 uplink port, install a QSFP-to-SFP adapter, such as the CVR-QSFP-SFP10G adapter, in the QSFP port and then install the SFP+ or SFP transceiver. The switch automatically sets the port speed to the speed of the installed transceiver.

Connecting a Console to the Switch

Before you create a network management connection for the switch or connect the switch to the network, you must create a local management connection through a console terminal. And then configure an IP address for the switch. You can use the console to perform the following functions, each of which can be performed through the management interface after you make that connection:

- Configure the switch using the command-line interface (CLI).
- Monitor network statistics and errors.
- Configure Simple Network Management Protocol (SNMP) agent parameters.
- Download software updates.

You make this local management connection between the asynchronous serial port on a supervisor module and a console device capable of asynchronous transmission. Typically, you can use a computer terminal as the console device. On the supervisor modules, you use the console serial port.



Note Before you can connect the console port to a computer terminal, make sure that the computer terminal supports VT100 terminal emulation. The terminal emulation software makes communication between the switch and computer possible during setup and configuration.

Before you begin

- The switch must be fully installed in its rack, which is connected to a power source, and grounded.
- The necessary cabling for the console, management, and network connections must be available.
 - An RJ-45 rollover cable provided in the switch accessory kit.
 - Network cabling is routed to the location of the installed switch.

Step 1 Configure the console device to match the following default port characteristics:

- 9600 baud
- 8 data bits
- 1 stop bit
- No parity

Step 2 Connect an RJ-45 rollover cable to the console port on the switch.

You can find this cable in the accessory kit.

Step 3 Route the RJ-45 rollover cable to the console or modem.

Step 4 Connect the other end of the RJ-45 rollover cable to the console or to a modem.

What to do next

You are ready to create the initial switch configuration (see [Creating the Initial Switch Configuration, on page 27](#)).

Creating the Initial Switch Configuration

You assign an IP address to the switch management interface so that you can then connect the switch to the network.

When you initially power up the switch, it boots up and asks you a series of questions to configure the switch. To connect the switch to the network, you can use the default choices for each configuration except the IP address, which you must provide. You can perform the other configurations later as described in the *Cisco Nexus 9000 Series NX-OS Fundamentals Configuration Guide*.



Note Know the unique name that is needed to identify the switch among the devices in the network.

Before you begin

- A console device must be connected with the switch.
- The switch must be connected to a power source.
- Determine the IP address and the netmask that is needed for the Management (Mgmt0) interface.

Step 1 Power up the switch by connecting each installed power supply to an AC circuit.

If you are using the combined or power-supply ($n+1$) power mode, connect all the power supplies to the same AC circuit. If you are using the input-source ($n+n$) power mode, connect half of the power supplies to one AC circuit. And connect the other half of the power supplies to another AC circuit.

The Input and Output LEDs on each power supply light up (green) when the power supply units are sending power to the switch, and the software asks you to specify a password to use with the switch.

Step 2 Enter a new password to use for this switch.

The software checks the security strength of your password and rejects your password if it is not considered to be a strong password. To increase the security strength of your password, make sure that it adheres to the following guidelines:

- At least eight characters
- Minimizes or avoids the use of consecutive characters (such as "abcd").
- Minimizes or avoids repeating characters (such as "aaabbb").
- Does not contain recognizable words from the dictionary.
- Does not contain proper names.
- Contains both uppercase and lowercase characters
- Contains numbers and letters

Examples of strong passwords include the following:

- If2CoM18
- 2004AsdfLkj30
- Cb1955S21

Note Clear text passwords cannot include the dollar sign (\$) special character.

Tip If a password is trivial (such as a short, easy-to-decipher password), the software will reject your password configuration. Be sure to configure a strong password as explained in this step. Passwords are case-sensitive.

If you enter a strong password, the software asks you to confirm the password.

Step 3 Enter the same password again.

If you enter the same password, the software accepts the password and begins asking a series of configuration questions.

Step 4 Until you are asked for an IP address, you can enter the default configuration for each question.

Repeat this step for each question until you are asked for the Mgmt0 IPv4 address.

Step 5 Enter the IP address for the management interface.

The software asks for the Mgmt0 IPv4 netmask.

Step 6 Enter a network mask for the management interface.

The software asks if you need to edit the configuration.

Step 7 Enter **no** not to edit the configuration.

The software asks if you need to save the configuration.

Step 8 Enter **yes** to save the configuration.

What to do next

You can now set up the management interface for each supervisor module on the switch.

Setting Up the Management Interface

The RJ-45 and/or SFP management ports provide out-of-band management, which enables you to use the command-line interface (CLI) to manage the switch by its IP address. You can use one of these ports depending on the cable and connectors that you are using to connect the management interface to the network.

Before you begin

- The switch must be powered on.
- The switch must be initially configured using a console.

-
- Step 1** Connect the management cable into the management port on the switch. For shorter connections, you can use a cable with RJ-45 connectors. For longer connections, you can use an optical cable with SFP transceivers (LH or SX type).
- Note** Use only one of these management ports—the switch does not support the use of both management ports.
- Step 2** Connect the other end of the cable to a 10/100/1000 or SFP port on a network device.
-

Connecting Interface Ports to Other Devices

After you perform the initial configuration for the switch and create a management connection, you are ready to connect the interface ports on the switch to other devices. Depending on the types of interface ports on the switch, you will need to use interface cables with QSFP28, QSFP+, SFP+, SFP transceivers, or RJ-45 connectors to connect the switch to other devices.



-
- Note** If you need to use SFP+ or SFP transceivers in a QSFP+ or QSFP28 uplink port, install a QSFP-to-SFP adapter, such as the CVR-QSFP-SFP10G adapter, in the QSFP port and then install the SFP+ or SFP transceiver. The switch automatically sets the port speed to the speed of the installed transceiver.
-

If the transceivers that you are using can be separated from their optical cables, install the transceivers without their cables before inserting the cables into the transceivers. This helps to prolong the life of both the transceiver and cables. When removing transceivers from the switch, it is best to remove the optical cable first and then remove the transceiver.

To determine which transceivers, adapters, and cables are supported by this switch, see the [Cisco Transceiver Modules Compatibility](#) Information document.



CHAPTER 5

Replacing Components

- [Replacing a Fan Module During Operations, on page 31](#)
- [Replacing a Power Supply Module, on page 32](#)

Replacing a Fan Module During Operations

All fan and power supply modules must have the same airflow direction or else an error can occur with the switch overheating and shutting down. You can determine the airflow direction of a fan module by the color of the stripe on the front of the module. If the fan module has a blue stripe for port-side exhaust airflow, the power supplies must have blue coloring for the same airflow direction. If the fan module has a burgundy stripe for port-side intake airflow, the power supplies must have burgundy coloring for the same airflow direction. To avoid over heating the switch, make sure that the fan modules are positioned in one of the following ways:

- For port-side exhaust airflow with blue coloring, position the fan modules in a cold aisle.
- For port-side intake airflow with burgundy coloring, position the ports in a cold aisle.

Before you begin

Before you can replace a fan module, ensure that the following conditions exist:

- The replacement fan module must have the same airflow direction as the other modules in the chassis.

If you must replace the fan module during operations and the above conditions are not met, leave the fan module that you need to replace in the chassis to preserve the designed airflow until you have the required module.

Step 1 Remove the fan module that you need to replace as follows:

- a) Place the removed module on an antistatic surface or in an antistatic bag. If possible, repack the module in its packing materials for safe shipping or storage.

Step 2 Follow these steps to replace the missing fan module within two minutes to avoid a shutdown.

- a) Remove the replacement fan module from its packing materials and place it on an antistatic surface.

Hold the module by its handle and do not touch the electrical connectors on its backside. Also, to protect the electrical connectors, avoid letting them come in contact with anything other than the electrical connectors inside the chassis.

- b) Position the fan module in front of the open fan slot (be sure that the backside of the module with the electrical connectors is positioned to enter the slot first) and slide the module all the way into the chassis until its front side comes in contact with the chassis. For the last 0.2 inches (0.5 cm), carefully mount the module onto the chassis connectors by pushing more firmly, but do not force the module if it does not move further (excessive force can damage the connectors).

Note If you are not able to push the module all the way into the slot, carefully slide the module out of the slot and check its electrical connectors for damage. If damaged, contact Cisco Technical Assistance for help. If undamaged, repeat this step to reinstall the module.

- c) Verify that the STS LED turns on and becomes green.

If the STS LED does not turn on, slide the module out of the chassis, and visually check the electrical connectors on the back side of the chassis for damage. If damaged, contact Cisco Technical Assistance for help. If undamaged, repeat the previous step to reinstall the module.

Replacing a Power Supply Module

The switch requires two power supplies for redundancy. With one power supply providing the necessary power for operations, you can replace the other power supply during operations so long as the new power supply has the same airflow direction as the other modules in the chassis.

You can replace a power supply with another supported power supply that has the same power source type as the other installed power supply. Additionally, the airflow direction of the power supply must match or conform to the airflow direction of the installed fan modules. For the airflow direction used by the switch, see the coloring of the fan modules.

Removing an AC Power Supply

To remove an AC power supply, you must first disconnect the power cable and then remove the module from the chassis.

Before you begin

- To replace a power supply during operations, you must have a functioning power supply providing power to the switch while you replace the other power supply. If there is only one power supply installed in the switch and you need to replace it, install the new power supply in the open slot and power it up before removing the original power supply.
- Ensure that the chassis is grounded. For grounding instructions, see [Grounding the Chassis, on page 20](#).

Step 1 Pull the power cord out from the power receptacle on the power supply to be removed and verify that the LED turns off.

Note The LED might be on and amber colored to indicate that the input power has been disconnected.

Step 2 Remove the power supply from the chassis by pushing and holding its thumb latch to the left and pulling the power supply part way out of the chassis.

- Step 3** Place your other hand under the power supply to support it while you slide it out of the chassis. Either place the power supply on an antistatic surface or pack it in its packing materials.
- Step 4** If the power supply slot is to remain empty, install a blank power supply filler panel (part number N2200-P-BLNK).

What to do next

You are ready to install the replacement power supply.

Installing an AC Power Supply

You can replace one power supply while the other one provides power to the switch.

Before you begin

- The power supply that you are installing must be capable of using the same airflow direction as the fan trays installed in the same switch and it must use the same type of power source as the other power supply installed in the same switch (do not mix AC and DC power supplies in the same switch).



Note If the power supply that you are replacing has a different color handle than the replacement power supply, verify that it has or will have the same airflow direction as the other modules in the switch.

- An AC power source must be within reach of the power cable that will be used with the replacement power supply. If you are using $n+n$ power redundancy, there must be a separate power source for each power supply installed in the chassis. Otherwise, only one power source is required.
- There must be an earth ground connection to the chassis that you are installing the replacement module. Typically, the chassis is grounded by its metal-to-metal connection with a grounded rack. If you need to ground the chassis, see [Grounding the Chassis, on page 20](#).

-
- Step 1** Holding the replacement power supply with one hand underneath the module and the other hand holding the handle, turn the power supply so that its release latch is on the side and align the back end of the power supply (the end with the electrical connections) to the open power supply slot before carefully sliding the power supply all the way into the slot until it clicks into place.

Note If the power supply does not fit into the open slot, turn the module over before sliding it carefully into the open slot.

- Step 2** Test the installation by trying to pull the power supply out of the slot without using the release latch. If the power supply does not move out of place, it is secured in the slot. If the power supply moves, carefully press it all the way into the slot until it clicks in place.
- Step 3** Attach the power cable to the electrical outlet on the front of the power supply.
- Step 4** Make sure that the other end of the power cable is attached to the appropriate power source for the power supply.

Note Depending on the outlet receptacle on your power distribution unit, you might need the optional jumper cable to connect the switch to your outlet receptacle.

Step 5 Verify that the power supply is operational by making sure that the power supply LED is green.



APPENDIX **A**

Rack Specifications

- [Overview of Racks, on page 35](#)
- [General Requirements for Cabinets and Racks, on page 35](#)
- [Requirements Specific to Standard Open Racks, on page 36](#)
- [Requirements Specific to Perforated Cabinets, on page 36](#)
- [Cable Management Guidelines, on page 36](#)

Overview of Racks

You can install the switch in the following types of cabinets and racks, assuming an external ambient air temperature range of 0 to 104°F (0 to 40°C):

- Standard perforated cabinets
- Solid-walled cabinets with a roof fan tray (bottom to top cooling)
- Standard open racks



Note If you are selecting an enclosed cabinet, we recommend one of the thermally validated types, either standard perforated or solid-walled with a fan tray.



Note We do not recommend that you use racks that have obstructions (such as power strips), because the obstructions could impair access to field-replaceable units (FRUs).

General Requirements for Cabinets and Racks

The cabinet or rack must also meet the following requirements:

- Standard 19-inch (48.3 cm) (two- or four-post EIA cabinet or rack, with mounting rails that conform to English universal hole spacing per section 1 of ANSI/EIA-310-D-1992). For more information, see [Requirements Specific to Perforated Cabinets, on page 36](#).

- The minimum vertical rack space requirement per chassis is:
 - For a one RU (rack unit) switch, 1.75 inches (4.4 cm)
 - For a one and a half RU (rack unit) switch, 2.63 (6.68 cm)
 - For a two RU (rack unit) switch, 3.5 inches (8.8 cm)
 - For a three RU (rack unit) switch, 5.25 inches (13.3 cm)
- The width between the rack-mounting rails must be at least 17.75 inches (45.0 cm) if the rear of the device is not attached to the rack. For four-post EIA racks, this measurement is the distance between the two front rails.

Four-post EIA cabinets (perforated or solid-walled) must meet the following requirements:

- The minimum spacing for the bend radius for fiber-optic cables should have the front-mounting rails of the cabinet offset from the front door by a minimum of 3 inches (7.6 cm).
- The distance between the outside face of the front mounting rail and the outside face of the back mounting rail should be 23.0 to 30.0 inches (58.4 to 76.2 cm) to allow for rear-bracket installation.

Requirements Specific to Standard Open Racks

If you are mounting the chassis in an open rack (no side panels or doors), ensure that the rack meets the following requirements:

- The minimum vertical rack space per chassis must be equal to the rack unit (RU) of the chassis. One rack unit is equal to 1.75 inches (4.4 cm).
- The distance between the chassis air vents and any walls should be 2.5 inches (6.4 cm).

Requirements Specific to Perforated Cabinets

A perforated cabinet has perforations in its front and rear doors and side walls. Perforated cabinets must meet the following requirements:

- The front and rear doors must have at least a 60 percent open area perforation pattern, with at least 15 square inches (96.8 square cm) of open area per rack unit of door height.
- The roof should be perforated with at least a 20 percent open area.
- The cabinet floor should be open or perforated to enhance cooling.

The Cisco R Series rack conforms to these requirements.

Cable Management Guidelines

To help with cable management, you might want to allow additional space in the rack above and below the chassis to make it easier to route all of the fiber optic or copper cables through the rack.



APPENDIX **B**

System Specifications

- [Environmental Specifications, on page 37](#)
- [Switch Dimensions, on page 37](#)
- [Switch and Module Weights and Quantities, on page 38](#)
- [Transceiver and Cable Specifications, on page 38](#)
- [Switch Power Input Requirements, on page 38](#)
- [Power Specifications, on page 38](#)
- [Power Cable Specifications, on page 39](#)
- [Regulatory Standards Compliance Specifications, on page 40](#)

Environmental Specifications

Environment		Specification
Temperature	Ambient operating temperature	32 to 104°F (0 to 40°C)
	Ambient nonoperating	−40 to 158°F (−40 to 70°C)
Relative humidity	Nonoperating	5 to 95%
	Operating	5 to 90%
Altitude	Altitude rating is based on power supply installed; see critical components list in the system CB report for altitude rating.	

Switch Dimensions

Switch	Width	Depth	Height
Cisco Nexus 9348D-GX2A	17.41 inches (44.23 cm)	29.82 in (75.76 cm)	1.72 inches (4.4 cm) (1 RU)

Switch and Module Weights and Quantities

Component	Weight per Unit	Quantity
Cisco Nexus 9348D-GX2A Chassis (N9K-C9348D-GX2A)	51.2 lb (23.22 kg)	1
Fan Module	—	4
– Port-side intake (burgundy) (NXA-FAN-160CFM-PI)	1.35 lb (0.61 kg)	
Power Supply module	—	2 (1 for operations and 1 for redundancy)
– 3200-W AC/HVDC port-side intake (burgundy) (NXA-PAC-3200W-PI)	3.6 lb (1.63 kg)	

Transceiver and Cable Specifications

To determine which transceivers, adapters, and cables are supported by this switch, see <https://www.cisco.com/c/en/us/support/interfaces-modules/transceiver-modules/products-device-support-tables-list.html>.

To see the transceiver specifications and installation information, see <https://www.cisco.com/c/en/us/support/interfaces-modules/transceiver-modules/products-device-support-tables-list.html>.

Switch Power Input Requirements

The following table lists the typical amount of power that the switch consumes. It also lists the maximum amount of power that you must provision for the switch and power supply for peak conditions.



Note Some power supplies have capabilities that are greater than the maximum power requirements for a switch. To determine the power consumption characteristics for the switch, use the typical and maximum requirements that are listed in the following table.

Switch	Typical Power Consumption (AC or DC)	Maximum Power Consumption (AC or DC)	Heat Dissipation Requirement
Cisco Nexus 9348D-GX2A	1380 W	3124 W	10,659.531 BTUs per hour

Power Specifications

Power specifications include the specifications for each type of power supply module.

3200-W AC/HVDC Power Supply Specifications

Property	Specification
Power	3200 W
AC Range	100-120 VAC; 16A Max. 50/60Hz
HVAC Range	200-240 VAC; 16A Max. 50/60Hz
HVDC Range	240 VDC; 14.5 Max.
Input Voltage	264 to 300 VAC
Frequency	47 to 63 Hz
Efficiency	90% or greater (20 to 100% load)
Redundancy Modes	Combined, $n+1$, and $n+n$
RoHS Compliance	Yes
Hot Swappable	Yes

3200-W DC/HVDC Power Supply Specifications

Property	Specification
Power	3200 W
DC Range	100-120 VDC; 16A Max. 50/60Hz
HVDC Range	240 VDC; 14.5 Max.
Input Voltage	-40 to -72 VDC
Frequency	47 to 63 Hz
Efficiency	90% or greater (20 to 100% load)
Redundancy Modes	Combined, $n+1$, and $n+n$
RoHS Compliance	Yes
Hot Swappable	Yes

Power Cable Specifications

The following sections specify the power cables that you can order and use with this switch.

Power Cables for NXA-PAC-3200W Power Supplies

Cable	Description
CAB-AC-16A-AUS	Power Cord, 16A, 250 VAC, Australia and New Zealand
CAB-AC-16A-CH	Power Cord, 16A, 250 VAC, Peoples Republic of China
CCAB-AC-2500W-EU	Power Cord, 16A, 250 VAC, Continental Europe
CAB-AC-2500W-ISRL	Power Cord, 16A, 250 VAC, Israel
CAB-AC-2500W-US1	Power Cord, 16A, 250 VAC, Japan and North America (nonlocking) 200-240VAC operation
CAB-AC-C6K-TWLK	Power Cord, 16A, 250 VAC, Japan and North America(locking) 200-240VAC operation
CAB-C19-CBN	Power Cord, 16A, 250 VAC, Power distribution unit (PDU)
CAB-ACS-16	Power Cord, 16A, 250 VAC, Switzerland
CAB-AC-C19-TW	Power Cord, 16A, 250 VAC, C19, Taiwan More
CAB-9K16A-BRZ	Power Cord, 16A, 250 VAC, Brazil, Src Plug EL224-C19
PWR-CORD10-IND	Power Cord, IEC60320/ C19, IS16A3,7.0M, India
CAB-IR2073-C19-AR	Power Cord, IRSM 2073 to IEC-C19 14ft Argen

Regulatory Standards Compliance Specifications

The following table lists the regulatory standards compliance for the switch.

Table 1: Regulatory Standards Compliance: Safety and EMC

Specification	Description
Regulatory compliance	Products should comply with CE Markings according to directives 2004/108/EC and 2006/95/EC.

Specification	Description
Safety	<ul style="list-style-type: none"> • CAN/CSA-C22.2 No. 60950-1 Second Edition • CAN/CSA-C22.2 No. 62368-1-19 Third Edition • NRTL 60950-1 Second Edition • IEC 62368-1 • EN 62368-1 • AS/NZS 62368-1 • GB4943 • UL 62368-1
EMC: Emissions	<ul style="list-style-type: none"> • 47CFR Part 15 (CFR 47) Class A • AS/NZS CISPR22 Class A • CISPR22 Class A • EN55022 Class A • ICES003 Class A • VCCI Class A • EN61000-3-2 • EN61000-3-3 • KN22 Class A • CNS13438 Class A
EMC: Immunity	<ul style="list-style-type: none"> • EN55024 • CISPR24 • EN300386 • KN 61000-4 series
RoHS	The product is RoH-6 compliant with exceptions for leaded-ball grid-array (BGA) balls and lead press-fit connectors.



APPENDIX C

LEDs

- [Switch Chassis LEDs, on page 43](#)
- [Fan Module LEDs, on page 44](#)
- [Power Supply LEDs, on page 44](#)

Switch Chassis LEDs

The BCN, STS, and ENV, LEDs are located on the left side of the front of the switch. The port LEDs appear as triangles pointing up or down to the nearest port.

LED	Color	Status
BCN	Flashing blue	The operator has activated this LED to identify this switch in the chassis.
	Off	This switch is not being identified.
STS	Green	The switch is operational.
	Flashing amber	The switch is booting up.
	Amber	Temperature exceeds the minor alarm threshold.
	Red	Temperature exceeds the major alarm threshold.
	Off	The switch is not receiving power.
ENV	Green	Fans and power supply modules are operational.
	Amber	At least one fan or power supply module is not operating.
(port)	Green	Port admin state is 'Enabled', SFP is present and the interface is connected (that is, cabled, and the link is up).
	Amber	Port admin state is 'Disabled, or the SFP is absent, or both.
	Off	Port admin state is 'Enabled' and SFP is present, but interface is not connected.

Fan Module LEDs

The fan module LED is located below the air holes on the front of the module.

LED	Color	Status
STS	Green	The fan module is operational.
	Red	The fan module is not operational (fan is probably not functional).
	Off	Fan module is not receiving power.

Power Supply LEDs

The power supply LEDs are located on the lower right portion of the power supply. LEDs indicate the status for the module as shown in the following table.

LED	Status
Green	Power supply is on and outputting power to the switch.
Flashing green	Power supply is connected to an AC power source but not outputting power to the switch. The power supply may not be properly installed in the chassis.
off	Either all the installed power supplies are not receiving power or an uninstalled power supply is not receiving power.
Flashing amber	Power supply is operating but a warning condition has occurred—possibly one of the following conditions: <ul style="list-style-type: none"> • High temperature • High power • Slow power supply fan • Low voltage • Power supply is installed in the chassis but was disconnected from the power source.
Off	Power supply is installed without a connection to a power source.

LED	Status
Amber	<p>Power supply failure—possibly one of the following conditions:</p> <ul style="list-style-type: none">• Over voltage• Over current• Over temperature• Power supply fan failure.



APPENDIX **D**

Additional Kits

- Rack Mount Kit NXK-ACC-KIT2-2RU, on page 47
- Accessory Kit NXA-ACC-QDD-DC, on page 48

Rack Mount Kit NXK-ACC-KIT2-2RU

The following table lists and illustrates the contents for the 2-RU rack-mount kit (NXK-ACC-KIT2-2RU).

Illustration	Description	Quantity
	Rack-mount kit <ul style="list-style-type: none"> • Slider bracket (2) • Slider rails (2) • M4 x 7 mm mounting screws (12) 	1
	Ground lug kit <ul style="list-style-type: none"> • Two-hole lug (1) • M4 x 8-mm Phillips pan-head screws (2) 	1
Not applicable	EAC Compliance document	1
Not applicable	Hazardous substances list for customers in China	1

The following table lists and illustrates the console cable (CAB-CONSOLE-RJ45) that can be ordered.

Illustration	Description	Quantity
	Console cable with DB-9F and RJ-45F connectors	1

Accessory Kit NXA-ACC-QDD-DC

The following table lists and illustrates the port dust cover (NXA-ACC-QDD-DC).

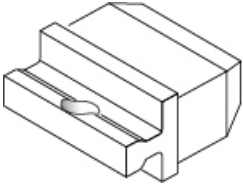
Illustration	Description	Quantity
	The port dust cover is designed to protect the connectors in unused ports and help divert airflow for better thermal dispensation.	16