



# RS720A-E11-RS24U

## 2U Rackmount Server User Guide



E19005  
Revised Edition V3  
August 2021

**Copyright © 2021 ASUSTeK COMPUTER INC. All Rights Reserved.**

No part of this manual, including the products and software described in it, may be reproduced, transmitted, transcribed, stored in a retrieval system, or translated into any language in any form or by any means, except documentation kept by the purchaser for backup purposes, without the express written permission of ASUSTeK COMPUTER INC. ("ASUS").

ASUS provides this manual "as is" without warranty of any kind, either express or implied, including but not limited to the implied warranties or conditions of merchantability or fitness for a particular purpose. In no event shall ASUS, its directors, officers, employees, or agents be liable for any indirect, special, incidental, or consequential damages (including damages for loss of profits, loss of business, loss of use or data, interruption of business and the like), even if ASUS has been advised of the possibility of such damages arising from any defect or error in this manual or product.

Specifications and information contained in this manual are furnished for informational use only, and are subject to change at any time without notice, and should not be construed as a commitment by ASUS. ASUS assumes no responsibility or liability for any errors or inaccuracies that may appear in this manual, including the products and software described in it.

Product warranty or service will not be extended if: (1) the product is repaired, modified or altered, unless such repair, modification or alteration is authorized in writing by ASUS; or (2) the serial number of the product is defaced or missing.

Products and corporate names appearing in this manual may or may not be registered trademarks or copyrights of their respective companies, and are used only for identification or explanation and to the owners' benefit, without intent to infringe.

# Contents

|                         |      |
|-------------------------|------|
| Safety information..... | vii  |
| About this guide.....   | viii |

## Chapter 1: Product Introduction

|       |                                |      |
|-------|--------------------------------|------|
| 1.1   | System package contents.....   | 1-2  |
| 1.2   | Serial number label.....       | 1-2  |
| 1.3   | System specifications .....    | 1-3  |
| 1.4   | Front panel features.....      | 1-6  |
| 1.5   | Rear panel features.....       | 1-6  |
| 1.6   | Internal features .....        | 1-8  |
| 1.7   | LED information .....          | 1-11 |
| 1.7.1 | Front panel LEDs .....         | 1-11 |
| 1.7.2 | Storage device status LED..... | 1-12 |
| 1.7.3 | LAN (RJ-45) LEDs .....         | 1-13 |
| 1.7.4 | Q-Code table.....              | 1-14 |

## Chapter 2: Hardware Information

|       |   |      |
|-------|---|------|
| 2.1   | Chassis cover.....                                  | 2-2  |
| 2.2   | Air ducts.....                                      | 2-4  |
| 2.3   | Central Processing Unit (CPU) .....                 | 2-7  |
| 2.3.1 | Installing the CPU and heatsink .....               | 2-7  |
| 2.4   | System memory .....                                 | 2-10 |
| 2.4.1 | Overview .....                                      | 2-10 |
| 2.4.2 | Memory Configurations.....                          | 2-11 |
| 2.4.3 | Installing a DIMM on a single clip DIMM socket..... | 2-12 |
| 2.4.4 | Removing a DIMM .....                               | 2-12 |
| 2.5   | Storage devices.....                                | 2-13 |

# Contents

- 2.6 Expansion slot.....2-16**
  - 2.6.1 Installing an expansion card to riser card bracket 1.....2-17
  - 2.6.2 Installing an expansion card to riser card bracket 2.....2-20
  - 2.6.3 Installing an expansion card to riser card bracket 3.....2-23
  - 2.6.4 Installing an expansion card to riser card bracket 4.....2-26
  - 2.6.5 Installing an OCP 3.0 slot baseboard and OCP 3.0 card to the riser card bracket.....2-29
  - 2.6.6 Installing an ethernet expansion card to the riser card bracket .....2-33
  - 2.6.7 Installing GPU cards (on selected models).....2-34
  - 2.6.8 Installing an ASUS PIKE II card.....2-44
  - 2.6.9 Installing M.2 (NGFF) cards.....2-48
  - 2.6.10 Configuring an expansion card .....2-49
- 2.7 Cable connections .....2-50**
- 2.8 SATA/SAS backplane cabling.....2-51**
- 2.9 Removable/optional components.....2-53**
  - 2.9.1 System fans .....2-53
  - 2.9.2 Redundant power supply module.....2-57

## Chapter 3: Installation Options

- 3.1 Tool-less Friction Rail Kit.....3-2**
- 3.2 Installing the tool-less rack rail .....3-3**
- 3.3 Rail kit dimensions .....3-5**
- 3.4 Cable management arm (optional for 1200 mm rack rails).....3-6**
  - 3.4.1 Attaching the cable management arm .....3-6

## Chapter 4: Motherboard Information

- 4.1 Motherboard layout.....4-2**
- 4.2 Jumpers .....4-4**
- 4.3 Internal LEDs.....4-9**
- 4.4 Internal connectors.....4-11**

# Contents

## Chapter 5: BIOS Setup

|            |  |             |
|------------|--|-------------|
| <b>5.1</b> | <b>Managing and updating your BIOS .....</b> | <b>5-2</b>  |
| 5.1.1      | ASUS CrashFree BIOS 3 utility.....           | 5-2         |
| 5.1.2      | ASUS EZ Flash Utility .....                  | 5-3         |
| 5.1.3      | BUPDATER utility .....                       | 5-4         |
| <b>5.2</b> | <b>BIOS setup program .....</b>              | <b>5-6</b>  |
| 5.2.1      | BIOS menu screen.....                        | 5-7         |
| 5.2.2      | Menu bar .....                               | 5-7         |
| 5.2.3      | Menu items.....                              | 5-8         |
| 5.2.4      | Submenu items .....                          | 5-8         |
| 5.2.5      | Navigation keys.....                         | 5-8         |
| 5.2.6      | General help.....                            | 5-8         |
| 5.2.7      | Configuration fields .....                   | 5-8         |
| 5.2.8      | Pop-up window.....                           | 5-8         |
| 5.2.9      | Scroll bar.....                              | 5-8         |
| <b>5.3</b> | <b>Main menu .....</b>                       | <b>5-9</b>  |
| 5.3.1      | System Language [English] .....              | 5-9         |
| 5.3.2      | System Date [Day xx/xx/xxxx].....            | 5-9         |
| 5.3.3      | System Time [xx:xx:xx] .....                 | 5-9         |
| <b>5.4</b> | <b>Performance Tuning menu.....</b>          | <b>5-10</b> |
| <b>5.5</b> | <b>Advanced menu .....</b>                   | <b>5-11</b> |
| 5.5.1      | Trusted Computing.....                       | 5-12        |
| 5.5.2      | PSP Firmware Versions .....                  | 5-12        |
| 5.5.3      | APM Configuration .....                      | 5-12        |
| 5.5.4      | Onboard LAN Configuration.....               | 5-13        |
| 5.5.5      | Serial Port Console Redirection .....        | 5-14        |
| 5.5.6      | CPU Configuration .....                      | 5-18        |
| 5.5.7      | PCI Subsystem Settings .....                 | 5-19        |
| 5.5.8      | USB Configuration .....                      | 5-20        |
| 5.5.9      | Network Stack Configuration.....             | 5-21        |
| 5.5.10     | CSM Configuration.....                       | 5-22        |
| 5.5.11     | NVMe Configuration.....                      | 5-23        |
| 5.5.12     | SATA Configuration .....                     | 5-24        |
| 5.5.13     | AMD Mem Configuration Status.....            | 5-24        |
| 5.5.14     | iSCSI Configuration.....                     | 5-25        |

# Contents

- 5.6 Chipset menu .....5-26
- 5.7 Security menu .....5-27
- 5.8 Boot menu .....5-31
- 5.9 Tool menu .....5-32
- 5.10 Save & Exit menu .....5-33
- 5.11 AMD CBS menu .....5-34
  - 5.11.1 CPU Common Options.....5-35
  - 5.11.2 DF Common Options .....5-39
  - 5.11.3 UMC Common Option.....5-41
  - 5.11.4 NBIO Common Options .....5-51
  - 5.11.5 NTB Common Options .....5-55
- 5.12 Event Logs menu .....5-56
  - 5.12.1 Change Smbios Event Log Settings .....5-56
  - 5.12.2 View Smbios Event Log.....5-57
- 5.13 Server Mgmt menu.....5-58

## Chapter 6: Driver Installation

- 6.1 Running the Support DVD.....6-2

## Appendix

- KMPP-D32 block diagram..... A-2
- Notices ..... A-3
- Service and Support ..... A-6

# Safety information

## Electrical Safety

- Before installing or removing signal cables, ensure that the power cables for the system unit and all attached devices are unplugged.
- To prevent electrical shock hazard, disconnect the power cable from the electrical outlet before relocating the system.
- When adding or removing any additional devices to or from the system, ensure that the power cables for the devices are unplugged before the signal cables are connected. If possible, disconnect all power cables from the existing system before you add a device.
- If the power supply is broken, do not try to fix it by yourself. Contact a qualified service technician or your dealer.

## Operation Safety

- Any mechanical operation on this server must be conducted by certified or experienced engineers.
- Before operating the server, carefully read all the manuals included with the server package.
- Before using the server, ensure all cables are correctly connected and the power cables are not damaged. If any damage is detected, contact your dealer as soon as possible.
- To avoid short circuits, keep paper clips, screws, and staples away from connectors, slots, sockets and circuitry.
- Avoid dust, humidity, and temperature extremes. Place the server on a stable surface.
- If you encounter technical problems with the product, contact a qualified service technician or your retailer.



---

This product is equipped with a three-wire power cable and plug for the user's safety. Use the power cable with a properly grounded electrical outlet to avoid electrical shock.

---

### Lithium-Ion Battery Warning

CAUTION! Danger of explosion if battery is incorrectly replaced. Replace only with the same or equivalent type recommended by the manufacturer. Dispose of used batteries according to the manufacturer's instructions.

### Heavy System

CAUTION! This server system is heavy. Ask for assistance when moving or carrying the system.

# About this guide

## Audience

This user guide is intended for system integrators, and experienced users with at least basic knowledge of configuring a server.

## Contents

This guide contains the following parts:

**1. Chapter 1: Product Introduction**

This chapter describes the general features of the server, including sections on front panel and rear panel specifications.

**2. Chapter 2: Hardware Information**

This chapter lists the hardware setup procedures that you have to perform when installing or removing system components.

**3. Chapter 3: Installation Options**

This chapter describes how to install optional components into the barebone server.

**4. Chapter 4: Motherboard Information**

This chapter gives information about the motherboard that comes with the server. This chapter includes the motherboard layout, jumper settings, and connector locations.

**5. Chapter 5: BIOS Setup**

This chapter tells how to change system settings through the BIOS Setup menus and describes the BIOS parameters.

**6. Chapter 6: Driver Installation**

This chapter provides instructions for installing the necessary drivers for different system components.

## Conventions

To ensure that you perform certain tasks properly, take note of the following symbols used throughout this manual.



**DANGER/WARNING:** Information to prevent injury to yourself when trying to complete a task.



**CAUTION:** Information to prevent damage to the components when trying to complete a task.



**IMPORTANT:** Instructions that you **MUST** follow to complete a task.



**NOTE:** Tips and additional information to help you complete a task.

## Typography

### **Bold text**

Indicates a menu or an item to select.

### *Italics*

Used to emphasize a word or a phrase.

### <Key>

Keys enclosed in the less-than and greater-than sign means that you must press the enclosed key.

Example: <Enter> means that you must press the Enter or Return key.

### <Key1>+<Key2>+<Key3>

If you must press two or more keys simultaneously, the key names are linked with a plus sign (+).

Example: <Ctrl>+<Alt>+<Del>

### Command

Means that you must type the command exactly as shown, then supply the required item or value enclosed in brackets.

Example: At the DOS prompt, type the command line:  
`format A: /S`

## References

Refer to the following sources for additional information, and for product and software updates.

### 1. **ASUS Control Center (ACC) user guide**

This manual tells how to set up and use the proprietary ASUS server management utility. Visit [asuscontrolcenter.asus.com](https://www.asus.com) for more information.

### 2. **ASUS websites**

The ASUS websites provide updated information for all ASUS hardware and software products. Visit <https://www.asus.com> for more information.



# Product Introduction

# 1

This chapter describes the general features of the chassis kit. It includes sections on front panel and rear panel specifications.

# 1.1 System package contents

Check your system package for the following items.

|                |   |
|----------------|---|
| Model Name     | RS720A-E11-RS24U  |
| Chassis        | ASUS R2P-A-R22475 2U Rackmount Chassis                        |
| Motherboard    | ASUS KMPP-D32 Server Board                                    |
| Component      | 1 x 1600W/2400W 80PLUS Platinum Power Supply                  |
|                | 24 x Hot-swap 2.5-inch Storage Device Trays                   |
|                | 1 x Front Panel Board   |
|                | 4 x System Fans   |
| Accessories    | 1 x AMD EPYC™ Support DVD                                     |
|                | 1 x Bag of Screws   |
|                | 2 x CPU Heatsink  |
| Optional Items | 2 x AC Power Cable  |
|                | 1+1 Redundant 1600W 80PLUS Platinum Power Supply or           |
|                | 1+1 Redundant 2400W 80PLUS Titanium Power Supply (Second PSU) |
|                | 1 x Friction Rail Kit   |



If any of the above items is damaged or missing, contact your retailer.

# 1.2 Serial number label

The product's serial number contains 12 characters such as xxSxxxxxxxxx and printed on the sticker at the server's front cover.

The correct serial number of the product is required if you need to request for support from the ASUS Technical Support team.

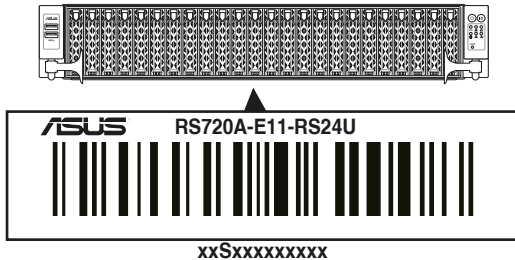

## 1.3 System specifications

The ASUS RS720A-E11-RS24U features the ASUS KMPP-D32 server board. The server supports AMD EPYC™ 7002/7003 Series processors plus other latest technologies through the chipsets onboard.

| Model Name        |                             | RS720A-E11-RS24U  |
|-------------------|-----------------------------|---|
| Motherboard       |                             | KMPP-D32  |
| Processor Support |                             | 2 x Socket SP3 (LGA 4094)<br>AMD EPYC™ 7002/7003 Series<br>xGMI (External Global Memory Interface Link)   |
| Core Logic        |                             | System on Chip (SoC)  |
| Memory            | Total Slots                 | 32 (8-channel per CPU, 16 DIMM per CPU)   |
|                   | Capacity                    | Maximum up to 4096GB  |
|                   | Memory Type                 | DDR4 3200/2933 RDIMM / LRDIMM / 3DS LRDIMM<br>* Please refer to <a href="http://www.asus.com">www.asus.com</a> for latest memory AVL update   |
|                   | Memory Size                 | 64GB, 32GB, 16GB (RDIMM)<br>64GB, 128GB (LRDIMM)<br>64GB, 128GB, 256GB (LRDIMM 3DS / 3DS RDIMM)<br>* Refer to <a href="http://www.asus.com/support">www.asus.com/support</a> for more information   |
| Expansion Slots   | Total PCI/PCI-E/ PIKE Slots | 9   |
|                   | Slot Type                   | 2 x PCIe Gen4 x8 or 1 x PCIe Gen4 x16, FHFL (CPU1 x1)<br>2 x PCIe Gen4 x8 or 1 x PCIe Gen4 x16, FHFL or OCP3.0* (CPU1 x1)<br>4 x PCIe Gen4 x8 or 2 x PCIe Gen4 x16, FHFL (CPU2 x2)<br>1 x PCIe Gen4 x8/x16**, LP (CPU2 x1)<br>* If choosing OCP3.0, another x8 slot will be limited to support PIKE card only<br>** If PCIe M.2 is in use, it will operate at x8 link<br>*** Installing GPU cards will occupy expansion slots |
|                   | M.2                         | 2 x M.2 (Up to 22110) (CPU2) (Support SATA/PCIe M.2)  |
|                   | Micro SD Card Slot          | 1   |
|                   | Proprietary Slot 1          | 1 x PCIe Gen4 x8 (for PIKE card only)   |
|                   | Proprietary Slot 2          | 4 x 1Gb RJ45 Lan Module Card or<br>2 x 10Gb RJ45 Lan Module Card  |
|                   | Disk Controller             | SATA Controller   |
| SAS Controller    |                             | <b>Optional:</b><br>ASUS PIKE II 3008 8-port SAS 12Gb/s HBA card<br>ASUS PIKE II 3108 8-port SAS HW 12Gb/s RAID card<br>Broadcom MegaRAID 9560-16i  |

(continued on the next page)

| Model Name      |                                 | RS720A-E11-RS24U   |
|-----------------|---------------------------------|--|
| Storage Bays    | Storage Bay                     | <p><b>24NVMe:</b><br/>24 x 2.5" Hot-Swap Drive Bays<br/>(up to 16 x NVMe+8 x NVMe/SATA/SAS*)</p> <p><b>12NVMe:</b><br/>24 x 2.5" Hot-Swap Drive Bays<br/>(up to 12 x NVMe+8 x SATA/SAS*)</p> <p>* SAS support only from optional SAS HBA/RAID card<br/>** Support tri-mode card</p> <p><b>Rear bays (Optional):</b><br/>Up to 2 x 2.5" Hot-Swap Drive Bays (NVMe/SATA)</p> |
|                 | Motherboard on-board connectors | <p>2 x M.2 connectors<br/>2 x miniSAS HD connector</p>   |
|                 | Default Cable                   | <p><b>24NVMe:</b><br/>2 x MINI SAS HD to MINI SAS HD Cable<br/>4 x SLIMELINE SAS HD to SLIMELINE SAS HD Cable</p> <p><b>12NVMe:</b><br/>2 x MINI SAS HD to MINI SAS HD Cable<br/>2 x SLIMELINE SAS HD to SLIMELINE SAS HD Cable</p>  |
| Networking      |                                 | <p>1 x Quad port Intel® I350-AM4 1G LAN controller or<br/>1 x Dual port Intel® X710-AT2 Gigabit 10G LAN controller<br/>1 x Management Port</p> <p><b>Optional OCP Adapter:</b><br/>Up to 100Gb/s Ethernet / InfiniBand Adapter</p>   |
| VGA             |                                 | Aspeed AST2600 64MB  |
| Graphic         |                                 | 4 double-wide GPUs or 8 single-wide GPUs   |
| Front I/O Ports |                                 | 2 x USB 3.2 Gen 1 ports  |
| Rear I/O Ports  |                                 | <p>2 x USB 3.2 Gen 1 ports<br/>1 x VGA port<br/>1 x RJ-45 Mgmt LAN port<br/>2 x 10G or 4 x 1G RJ-45 GbE LAN ports (Optional)<br/>1 x OCP 3.0 port</p>  |
| Switch/LED      |                                 | <p><b>Front Switch/LED:</b><br/>1 x Power Switch (w/ LED)<br/>1 x Reset Switch<br/>1 x Location Switch (w/ LED)<br/>1 x Storage Device Access LED<br/>1 x Message LED<br/>LAN 1-4 LED (on NIC module)</p>  |

(continued on the next page)

| Model Name  |                             | RS720A-E11-RS24U  |
|---|-----------------------------|---|
| Switch/LED  |                             | <b>Rear Switch/LED:</b><br>1 x Q-Code/Port 80 LED<br>1 x Power Switch (w/ LED)<br>1 x Location Switch (w/ LED)<br>1 x Message LED   |
| Security Options  |                             | TPM-SPI<br>PFR  |
| OS Support  |                             | Windows® Server 2019<br>RedHat® Enterprise Linux<br>SuSE® Linux Enterprise Server<br>CentOS<br>Ubuntu<br>VMware<br>* Please find the latest OS support from <a href="http://www.asus.com">http://www.asus.com</a> |
| Management Solution   | Software                    | ASUS Control Center   |
|   | Out of Band Remote Hardware | On-Board ASMB10-iKVM for KVM-over-IP  |
| Regulatory Compliance   |                             | BSMI, CE, C-Tick, FCC(Class A)  |
| Dimension   |                             | 840 mm x 449 mm x 88.1 mm (2U)  |
| Net Weight Kg (CPU, DRAM & storage device not included)                     |                             | 21.64 Kg  |
| Gross Weight Kg (CPU, DRAM & storage device not included, packing included) |                             | 27.85 Kg  |
| Power Supply (different configuration by region)                            |                             | 1+1 Redundant 1600W 80PLUS Platinum Power Supply or<br>1+1 Redundant 2400W 80PLUS Titanium Power Supply<br>Rating: 100-127/200-240Vac, 9.4A/4.72A (x2), 50/60Hz Class I<br>(240Vdc, 4.6A Only for China)          |
| Environment   |                             | Operating temperature: 10°C ~ 35°C<br>Non operating temperature: -40°C ~ 60°C<br>Non operating humidity: 20% ~ 90% (Non condensing)   |

\* Specifications are subject to change without notice.

## 1.4 Front panel features

The barebone server displays a simple yet stylish front panel with easily accessible features. The power and reset buttons, LED indicators, and two USB ports are located on the front panel.



Refer to section 1.7 LED information for the LED descriptions.

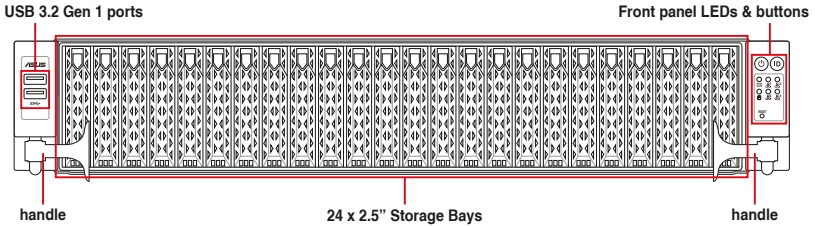

## 1.5 Rear panel features

The rear panel includes the expansion slots, system power sockets, and rear fans. The middle part includes the I/O shield with openings for the rear panel connectors on the motherboard.

### Standard model / GPU model

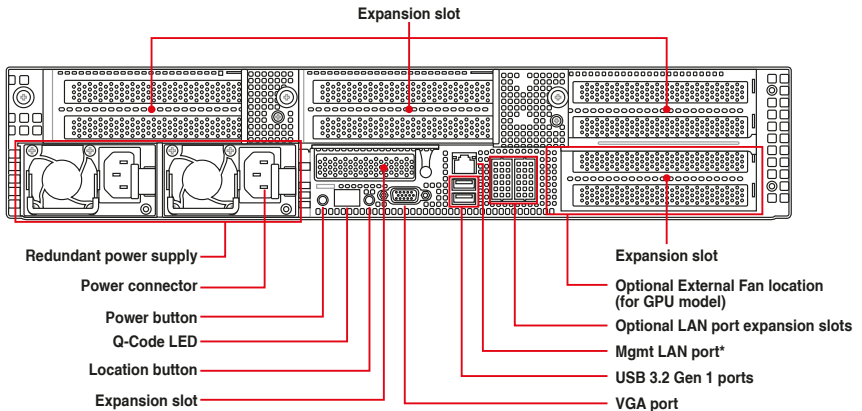

- Mgmt LAN port is for ASUS ASMB10-iKVM only.
- The Q-Code LED provides the most probable cause of an error code as a starting point for troubleshooting. The actual cause may vary from case to case.
- Refer to the Q-Code table for details.

## Standard model with rear bay

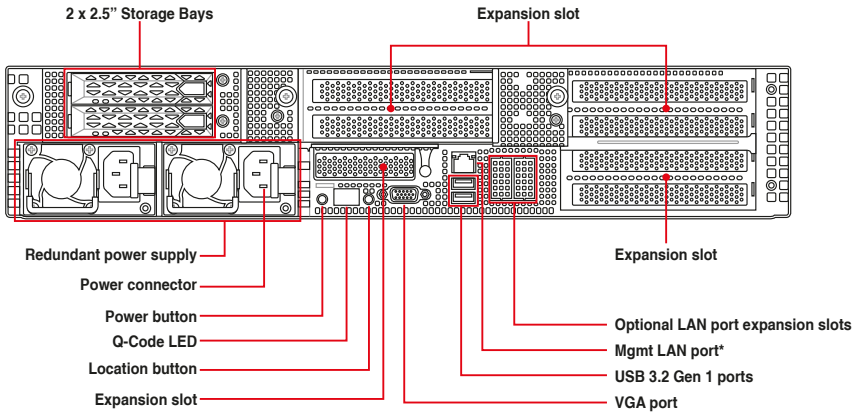

- Mgmt LAN port is for ASUS ASMB10-iKVM only.
- The Q-Code LED provides the most probable cause of an error code as a starting point for troubleshooting. The actual cause may vary from case to case.
- Refer to the Q-Code table for details.

## 1.6 Internal features

The barebone server includes the basic components as shown.

### 24 NVMe non-GPU model

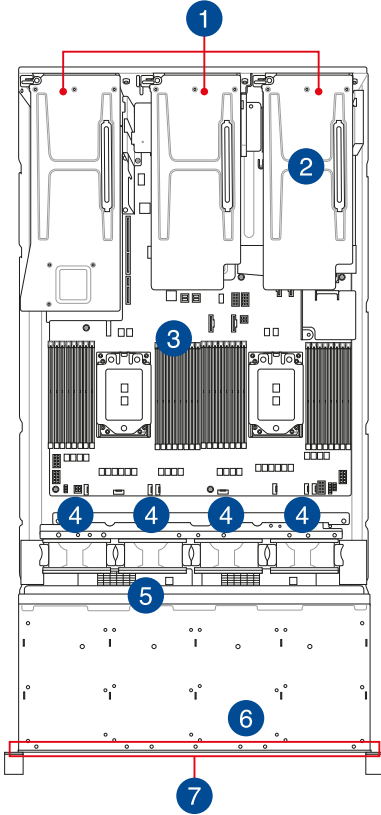

1. Riser card bracket
2. Redundant Power supply (hidden)
3. ASUS KMPP-D32 Server Board
4. System fans
5. SATA/SAS back panel
6. Front panel (hidden)
7. 24 x 2.5" storage device trays



The barebone server does not include a floppy disk drive. Connect a USB floppy disk drive to any of the USB ports on the front or rear panel if you need to use a floppy disk.



A protection film is pre-attached to the front cover before shipping. Please remove the protection film before turning on the system for proper heat dissipation.

**WARNING**  
**HAZARDOUS MOVING PARTS**  
**KEEP FINGERS AND OTHER BODY PARTS AWAY**

## 12 NVMe GPU model

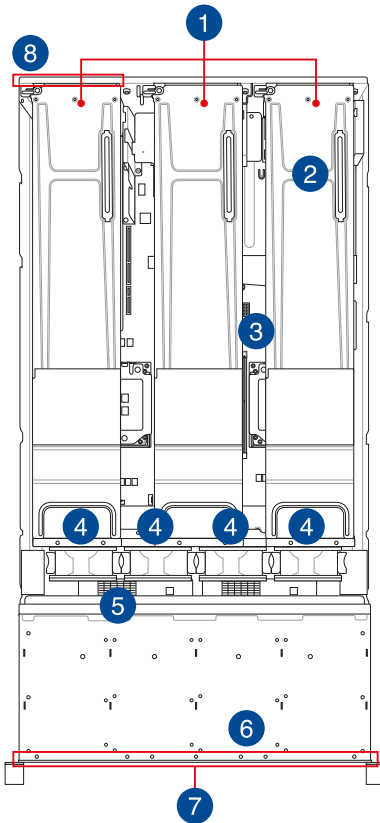

1. Riser card bracket
2. Redundant Power supply (hidden)
3. ASUS KMPP-D32 Server Board
4. System fans
5. SATA/SAS back panel
6. Front panel (hidden)
7. 24 x 2.5" storage device trays
8. External Fan\* (optional)



- Ensure to install the external fan when GPU is installed on slot 3 & 4.
- The barebone server does not include a floppy disk drive. Connect a USB floppy disk drive to any of the USB ports on the front or rear panel if you need to use a floppy disk.



A protection film is pre-attached to the front cover before shipping. Please remove the protection film before turning on the system for proper heat dissipation.

**WARNING**  
**HAZARDOUS MOVING PARTS**  
**KEEP FINGERS AND OTHER BODY PARTS AWAY**

### Standard model with rear bay

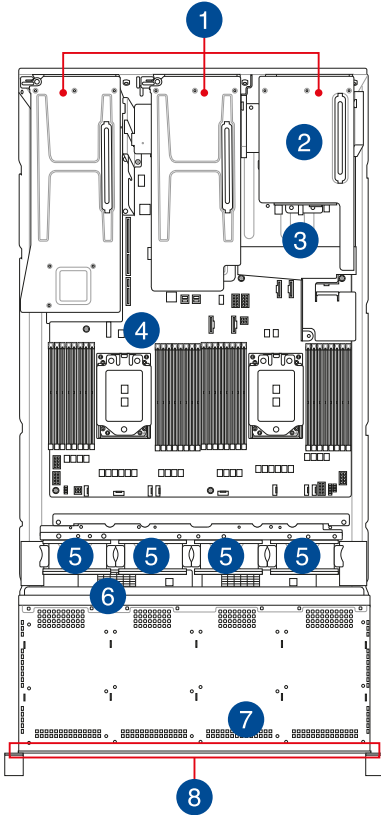

1. Riser card bracket
2. Redundant Power supply (hidden)
3. 2 x 2.5" storage device trays
4. ASUS KMPP-D32 Server Board
5. System fans
6. SATA/SAS/NVMe back panel
7. Front panel (hidden)
8. 24 x 2.5" storage device trays



The barebone server does not include a floppy disk drive. Connect a USB floppy disk drive to any of the USB ports on the front or rear panel if you need to use a floppy disk.



A protection film is pre-attached to the front cover before shipping. Please remove the protection film before turning on the system for proper heat dissipation.

**WARNING**  
**HAZARDOUS MOVING PARTS**  
**KEEP FINGERS AND OTHER BODY PARTS AWAY**

# 1.7 LED information

## 1.7.1 Front panel LEDs

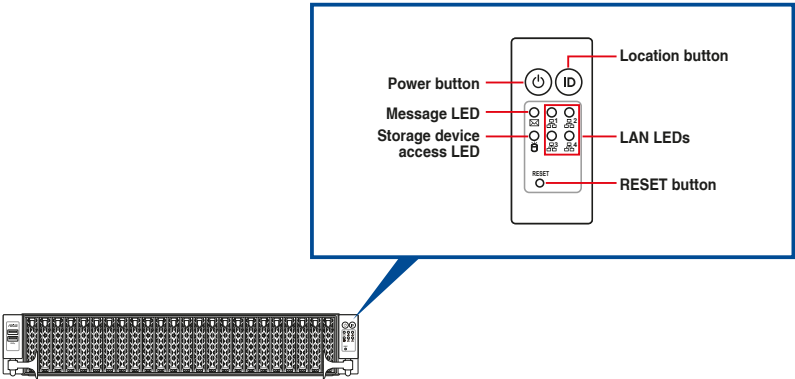

| LED                       | Icon | Display status | Description   |
|---------------------------|------|----------------|---|
| Power LED                 | ⏻    | ON             | System power ON   |
| Storage device access LED | 🗄️   | OFF            | No activity   |
|                           |      | Blinking       | Read/write data into the storage device                             |
| Message LED               | ✉️   | OFF            | System is normal; no incoming event                                 |
|                           |      | ON             | With the onboard ASMB10-iKVM: a hardware monitor event is indicated |
| LAN LEDs                  | 🌐    | OFF            | No LAN connection   |
|                           |      | Blinking       | LAN is transmitting or receiving data                               |
|                           |      | ON             | LAN connection is present   |
| Location LED              | ID   | ON             | Location switch is pressed  |
|                           |      | OFF            | Normal status (Press the location switch again to turn off)         |

## 1.7.2 Storage device status LED

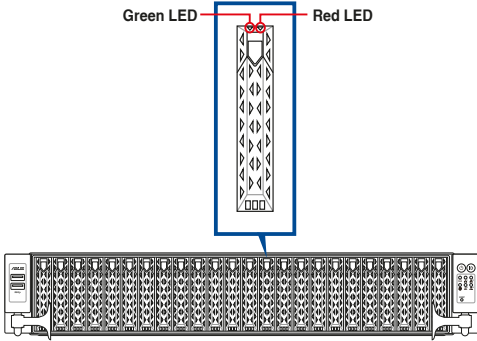

| Storage Device LED Description |          |   |
|--------------------------------|----------|---|
| Status (RED)                   | ON       | Storage device has failed                             |
|                                | Blinking | RAID rebuilding or locating                           |
| Activity (GREEN)               | ON       | Storage device power ON                               |
|                                | Blinking | Read/write data from/into the SATA/SAS storage device |
|                                | OFF      | Storage device not found                              |

### 1.7.3 LAN (RJ-45) LEDs

#### Intel® I350-AM4 1G LAN port LEDs

ACT/LINK LED    SPEED LED



| ACT/LINK LED |               | SPEED LED |                     |
|--------------|---------------|-----------|---------------------|
| Status       | Description   | Status    | Description         |
| OFF          | No link       | OFF       | 10 Mbps connection  |
| GREEN        | Linked        | ORANGE    | 100 Mbps connection |
| BLINKING     | Data activity | GREEN     | 1 Gbps connection   |

#### Intel® X710-AT2 Gigabit 10G LAN port LEDs

ACT/LINK LED    SPEED LED



| ACT/LINK LED |               | SPEED LED |                               |
|--------------|---------------|-----------|-------------------------------|
| Status       | Description   | Status    | Description                   |
| OFF          | No link       | OFF       | 10 Mbps / 100 Mbps connection |
| GREEN        | Linked        | ORANGE    | 1 Gbps connection             |
| BLINKING     | Data activity | GREEN     | 10 Gbps connection            |

## 1.7.4 Q-Code table

### AMD EPYC™ 7002 Series processors

| Action       | PHASE                                    | POST CODE                               | TYPE     | DESCRIPTION  |
|--------------|--|---|----------|--|
| SEC Start up | Security Phase                           | 0x01                                    | Progress | First post code                                    |
|              |  | 0x02                                    | Progress | Load BSP microcode                                 |
|              |  | 0x03                                    | Progress | Perform early platform Initialization              |
|              |  | 0x04                                    | Progress | Set cache as ram for PEI phase                     |
|              |  | 0x05                                    | Progress | Establish Stack                                    |
|              |  | 0x06                                    | Progress | CPU Early Initialization                           |
| PSP Boot     | PSP Boot Loader phase (Error Post Codes) | 0x00                                    | Error    | General - Success                                  |
|              |  | 0x01                                    | Error    | Generic Error Code                                 |
|              |  | 0x02                                    | Error    | Generic Memory Error                               |
|              |  | 0x03                                    | Error    | Buffer Overflow                                    |
|              |  | 0x04                                    | Error    | Invalid Parameter(s)                               |
|              |  | 0x05                                    | Error    | Invalid Data Length                                |
|              |  | 0x06                                    | Error    | Data Alignment Error                               |
|              |  | 0x07                                    | Error    | Null Pointer Error                                 |
|              |  | 0x08                                    | Error    | Unsupported Function                               |
|              |  | 0x09                                    | Error    | Invalid Service ID                                 |
|              |  | 0x0A                                    | Error    | Invalid Address                                    |
|              |  | 0x0B                                    | Error    | Out of Resource Error                              |
|              |  | 0x0C                                    | Error    | Timeout  |
|              |  | 0x0D                                    | Error    | data abort exception                               |
|              |  | 0x0E                                    | Error    | prefetch abort exception                           |
|              |  | 0x0F                                    | Error    | Out of Boundary Condition Reached                  |
|              |  | 0x10                                    | Error    | Data corruption                                    |
|              |  | 0x11                                    | Error    | Invalid command                                    |
|              |  | 0x12                                    | Error    | The package type provided by BR is incorrect       |
|              |  | 0x13                                    | Error    | Failed to retrieve FW header during FW validation  |
|              |  | 0x14                                    | Error    | Key size not supported                             |
|              |  | 0x15                                    | Error    | Agesa0 verification error                          |
|              |  | 0x16                                    | Error    | SMU FW verification error                          |
|              |  | 0x17                                    | Error    | OEM SINGING KEY verification error                 |
|              |  | 0x18                                    | Error    | Generic FW Validation error                        |
|              |  | 0x19                                    | Error    | RSA operation fail - bootloader                    |
|              |  | 0x1A                                    | Error    | CCP Passthrough operation failed - internal status |
|              |  | 0x1B                                    | Error    | AES operation fail                                 |
|              |  | 0x1C                                    | Error    | CCP state save failed                              |
|              |  | 0x1D                                    | Error    | CCP state restore failed                           |
| 0x1E         | Error                                    | SHA256 operation fail - internal status |          |  |
| 0x1F         | Error                                    | ZLib Decompression operation fail       |          |  |

(continued on the next page)

| Action   | PHASE                                    | POST CODE                                      | TYPE  | DESCRIPTION   |
|----------|--|--|-------|---|
| PSP Boot | PSP Boot Loader phase (Error Post Codes) | 0x20   | Error | HMAC-SHA256 operation fail - internal status                            |
|          |  | 0x21   | Error | Booted from boot source not recognized by PSP                           |
|          |  | 0x22   | Error | PSP directory entry not found   |
|          |  | 0x23   | Error | PSP failed to set the write enable latch                                |
|          |  | 0x24   | Error | PSP timed out because spirom took too long                              |
|          |  | 0x25   | Error | Cannot find BIOS directory  |
|          |  | 0x26   | Error | SpiRom is not valid   |
|          |  | 0x27   | Error | slave die has different security state from master                      |
|          |  | 0x28   | Error | SMI interface init failure  |
|          |  | 0x29   | Error | SMI interface generic error   |
|          |  | 0x2A   | Error | invalid die ID executes MCM related function                            |
|          |  | 0x2B   | Error | invalid MCM configuration table read from bootrom                       |
|          |  | 0x2C   | Error | Valid boot mode wasn't detected   |
|          |  | 0x2D   | Error | NVStorage init failure  |
|          |  | 0x2E   | Error | NVStorage generic error   |
|          |  | 0x2F   | Error | MCM 'error' to indicate slave has more data to send                     |
|          |  | 0x30   | Error | MCM error if data size exceeds 32B                                      |
|          |  | 0x31   | Error | Invalid client id for SVC MCM call                                      |
|          |  | 0x32   | Error | MCM slave status register contains bad bits                             |
|          |  | 0x33   | Error | MCM call was made in a single die environment                           |
|          |  | 0x34   | Error | PSP secure mapped to invalid segment (should be 0x400_0000)             |
|          |  | 0x35   | Error | No physical x86 cores were found on die                                 |
|          |  | 0x36   | Error | Insufficient space for secure OS (range of free SRAM to SVC stack base) |
|          |  | 0x37   | Error | SYSHUB mapping memory target type is not supported                      |
|          |  | 0x38   | Error | Attempt to unmap permanently mapped TLB to PSP secure region            |
|          |  | 0x39   | Error | Unable to map an SMN address to AXI space                               |
|          |  | 0x3A   | Error | Unable to map a SYSHUB address to AXI space                             |
|          |  | 0x3B   | Error | The count of CCXs or cores provided by bootrom is not consistent        |
|          |  | 0x3C   | Error | Uncompressed image size doesn't match value in compressed header        |
|          |  | 0x3D   | Error | Compressed option used in case where not supported                      |
| 0x3E     | Error                                    | Fuse info on all dies don't match              |       |   |
| 0x3F     | Error                                    | PSP sent message to SMU; SMU reported an error |       |   |

(continued on the next page)

| Action   | PHASE                                    | POST CODE | TYPE  | DESCRIPTION   |
|----------|--|-----------|-------|---|
| PSP Boot | PSP Boot Loader phase (Error Post Codes) | 0x40      | Error | Function RunPostX86ReleaseUnitTests failed in memcmp()                |
|          |  | 0x41      | Error | Interface between PSP to SMU not available.                           |
|          |  | 0x42      | Error | Timer wait parameter too large  |
|          |  | 0x43      | Error | Test harness module reported an error                                 |
|          |  | 0x44      | Error | x86 wrote C2PMSG_0 interrupting PSP                                   |
|          |  | 0x45      | Error | A write to an L3 register failed                                      |
|          |  | 0x46      | Error | Mini-BL   |
|          |  | 0x47      | Error | Mini-BL CCP HMAC Unit-test failed                                     |
|          |  | 0x48      | Error | Potential stack corruption in jump to Mini BL                         |
|          |  | 0x49      | Error | Error in Validate and Loading AGESA APOB SVC call                     |
|          |  | 0x4A      | Error | Correct fuse bits for DIAG_BL loading not set                         |
|          |  | 0x4B      | Error | The UmcProgramKeys() function was not called by AGESA                 |
|          |  | 0x4C      | Error | Secure unlock error   |
|          |  | 0x4D      | Error | Syshub register programming mismatch during readback                  |
|          |  | 0x4E      | Error | Family ID in MPO_SFUSE_SEC[7:3] not correct                           |
|          |  | 0x4F      | Error | An operation was invoked that can only be performed by the GM         |
|          |  | 0x50      | Error | Failed to acquire host controller semaphore to claim ownership of SMB |
|          |  | 0x51      | Error | Timed out waiting for host to complete pending transactions           |
|          |  | 0x52      | Error | Timed out waiting for slave to complete pending transactions          |
|          |  | 0x53      | Error | Unable to kill current transaction on host                            |
|          |  | 0x54      | Error | One of: Illegal command   |
|          |  | 0x55      | Error | An SMBus transaction collision detected                               |
|          |  | 0x56      | Error | Transaction failed to be started or processed by host                 |
|          |  | 0x57      | Error | An unsolicited SMBus interrupt was received                           |
|          |  | 0x58      | Error | An attempt to send an unsupported PSP-SMU message was made            |
|          |  | 0x59      | Error | An error/data corruption detected on response from SMU for sent msg   |
|          |  | 0x5A      | Error | MCM Steady-state unit test failed                                     |
|          |  | 0x5B      | Error | S3 Enter failed   |
|          |  | 0x5C      | Error | AGESA BL did not set PSP SMU reserved addresses via SVC call          |
|          |  | 0x5E      | Error | CcxSecBisiEn not set in fuse RAM                                      |
|          |  | 0x5F      | Error | Received an unexpected result   |

(continued on the next page)

| Action   | PHASE                                    | POST CODE  | TYPE  | DESCRIPTION   |
|----------|--|--|-------|---|
| PSP Boot | PSP Boot Loader phase (Error Post Codes) | 0x60   | Error | VMG Storage Init failed   |
|          |  | 0x61   | Error | Failure in mbedTLS user app   |
|          |  | 0x62   | Error | An error occured whilst attempting to SMN map a fuse register                         |
|          |  | 0x63   | Error | Fuse burn sequence/operation failed due to internal SOC error                         |
|          |  | 0x64   | Error | Fuse sense operation timed out  |
|          |  | 0x65   | Error | Fuse burn sequence/operation timed out waiting for burn done                          |
|          |  | 0x66   | Error | Failure status indicating that the given SecureOS has been                            |
|          |  | 0x67   | Error | This PSP FW was revoked   |
|          |  | 0x68   | Error | The platform model/vendor id fuse is not matching the BIOS public key token           |
|          |  | 0x69   | Error | The BIOS OEM public key of the BIOS was revoked for this platform                     |
|          |  | 0x6A   | Error | PSP level 2 directory not match expected value.                                       |
|          |  | 0x6B   | Error | BIOS level 2 directory not match expected value.                                      |
|          |  | 0x6C   | Error | HVB validation failure for BIOS RTM volume (OEM public/signature failed to validate). |
|          |  | 0x6D   | Error | Generic error indicating the CCP HAL initialization failed                            |
|          |  | 0x94   | Error | Knoll failed to idle correctly after being reset                                      |
|          |  | 0x95   | Error | Bad status returned by I2CKnollCheck  |
|          |  | 0x96   | Error | NACK to general call (no device on Knoll I2C bus)                                     |
|          |  | 0x97   | Error | Null pointer passed to I2CKnollCheck  |
|          |  | 0x98   | Error | Invalid device-ID found during Knoll authentication                                   |
|          |  | 0x99   | Error | Error during Knoll/Prom key derivation  |
| 0x9A     | Error                                    | Null pointer passed to Crypto function           |       |   |
| 0x9B     | Error                                    | Error in checksum from wrapped Knoll/Prom keys   |       |   |
| 0x9C     | Error                                    | Knoll returned an invalid response to a command  |       |   |
| 0x9D     | Error                                    | Bootloader failed in Knoll Send Command function |       |   |
| 0x9E     | Error                                    | No Knoll device found by verifying MAC           |       |   |

*(continued on the next page)*

| Action   | PHASE                                     | POST CODE  | TYPE     | DESCRIPTION  |
|----------|---|--|----------|--|
| PSP Boot | PSP Boot Loader phase (Status Post Codes) | 0xA0   | Progress | Bootloader successfully entered C Main                       |
|          |   | 0xA1   | Progress | Master initialized C2P / slave waited for master to init C2P |
|          |   | 0xA2   | Progress | HMAC key successfully derived                                |
|          |   | 0xA3   | Progress | Master got Boot Mode and sent boot mode to all slaves        |
|          |   | 0xA4   | Progress | SpiRom successfully initialized                              |
|          |   | 0xA5   | Progress | BIOS Directory successfully read from SPI to SRAM            |
|          |   | 0xA6   | Progress | Early unlock check   |
|          |   | 0xA7   | Progress | Inline Aes key successfully derived                          |
|          |   | 0xA8   | Progress | Inline-AES key programming is done                           |
|          |   | 0xA9   | Progress | Inline-AES key wrapper derivation is done                    |
|          |   | 0xAA   | Progress | Bootloader successfully loaded HW IP configuration values    |
|          |   | 0xAB   | Progress | Bootloader successfully programmed MBAT table                |
|          |   | 0xAC   | Progress | Bootloader successfully loaded SMU FW                        |
|          |   | 0xAD   | Progress | PSP and SMU configured WAFL                                  |
|          |   | 0xAE   | Progress | User mode test harness completed successfully                |
|          |   | 0xAF   | Progress | Bootloader loaded Agesa0 from SpiRom                         |
|          |   | 0xB0   | Progress | AGESA phase has completed                                    |
|          |   | 0xB1   | Progress | RunPostDramTrainingTests() completed successfully            |
|          |   | 0xB2   | Progress | SMU FW Successfully loaded to SMU Secure DRAM                |
|          |   | 0xB3   | Progress | Sent all required boot time messages to SMU                  |
|          |   | 0xB4   | Progress | Validated and ran Security Gasket binary                     |
|          |   | 0xB5   | Progress | UMC Keys generated and programmed                            |
|          |   | 0xB6   | Progress | Inline AES key wrapper stored in DRAM                        |
|          |   | 0xB7   | Progress | Completed FW Validation step                                 |
|          |   | 0xB8   | Progress | Completed FW Validation step                                 |
|          |   | 0xB9   | Progress | BIOS copy from SPI to DRAM complete                          |
|          |   | 0xBA   | Progress | Completed FW Validation step                                 |
|          |   | 0xBB   | Progress | BIOS load process fully complete                             |
|          |   | 0xBC   | Progress | Bootloader successfully release x86                          |
|          |   | 0xBD   | Progress | Early Secure Debug completed                                 |
| 0xBE     | Progress                                  | GetFWVersion command received from BIOS is completed |          |  |
| 0xBF     | Progress                                  | SMInfo command received from BIOS is completed       |          |  |

(continued on the next page)

| Action   | PHASE                                     | POST CODE  | TYPE     | DESCRIPTION   |
|----------|---|--|----------|---|
| PSP Boot | PSP Boot Loader phase (Status Post Codes) | 0xC0   | Progress | Successfully entered WarmBootResume()                   |
|          |   | 0xC1   | Progress | Successfully copied SecureOS image to SRAM              |
|          |   | 0xC2   | Progress | Successfully copied trustlets to PSP Secure Memory      |
|          |   | 0xC3   | Progress | About to jump to Secure OS (SBL about to copy and jump) |
|          |   | 0xC4   | Progress | Successfully restored CCP and UMC state on S3 resume    |
|          |   | 0xC5   | Progress | PSP SRAM HMAC validated by Mini BL                      |
|          |   | 0xC6   | Progress | About to jump to -t-base in Mini BL                     |
|          |   | 0xC7   | Progress | VMG ECDH unit test started                              |
|          |   | 0xC8   | Progress | VMG ECDH unit test passed                               |
|          |   | 0xC9   | Progress | VMG ECC CDH primitive unit test started                 |
|          |   | 0xCA   | Progress | VMG ECC CDH primitive unit test passed                  |
|          |   | 0xCB   | Progress | VMG SP800-108 KDF-CTR HMAC unit test started            |
|          |   | 0xCC   | Progress | VMG SP800-108 KDF-CTR HMAC unit test passed             |
|          |   | 0xCD   | Progress | VMG LAUNCH_* test started                               |
|          |   | 0xCE   | Progress | VMG LAUNCH_* test passed                                |
|          |   | 0xCF   | Progress | MP1 has been taken out of reset                         |
|          |   | 0xD0   | Progress | PSP and SMU Reserved Addresses correct                  |
|          |   | 0xD1   | Progress | Reached Naples steady-state WFI loop                    |
|          |   | 0xD2   | Progress | Knoll device successfully initialized                   |
|          |   | 0xD3   | Progress | 32-byte RandOut successfully returned from Knoll        |
| 0xD4     | Progress                                  | 32-byte MAC successfully received from Knoll.        |          |   |
| 0xD5     | Progress                                  | Knoll device verified successfully                   |          |   |
| 0xD6     | Progress                                  | Done enabling power for Knoll                        |          |   |
| 0xD7     | Progress                                  | Enter recovery mode due to trustlet validation fail. |          |   |
| 0xD8     | Progress                                  | Enter recovery mode due to OS validation fail.       |          |   |
| 0xD9     | Progress                                  | Enter recovery mode due to OEM public key not found. |          |   |

(continued on the next page)

| Action      | PHASE                                   | POST CODE                       | TYPE                       | DESCRIPTION                                  |
|-------------|---|---------------------------------|----------------------------|--|
| Quick VGA   | PEI(Pre-EFI Initialization) phase       | 0x10                            | Progress                   | PEI Core Entry                               |
|             |   | 0x11                            | Progress                   | PEI cache as ram CPU initial                 |
|             |   | 0x15                            | Progress                   | NB Initialization before installed memory    |
|             |   | 0x19                            | Progress                   | SB Initialization before installed memory    |
|             | DXE(Driver Execution Environment) phase | 0x32                            | Progress                   | CPU POST-Memory Initialization               |
|             |   | 0x33                            | Progress                   | CPU Cache Initialization                     |
|             |   | 0x34                            | Progress                   | Application Processor(s) (AP) Initialization |
|             |   | 0x35                            | Progress                   | BSP Selection                                |
|             |   | 0x36                            | Progress                   | CPU Initialization                           |
|             |   | 0x37                            | Progress                   | Pre-memory NB Initialization                 |
|             |   | 0x3B                            | Progress                   | Pre-memory SB Initialization                 |
|             |   | 0x4F                            | Progress                   | DXE Initial Program Load(PL)                 |
|             |   | 0x60                            | Progress                   | DXE Core Started                             |
|             |   | 0x61                            | Progress                   | DXE NVRAM Initialization                     |
|             |   | 0x62                            | Progress                   | SB run-time Initialization                   |
|             |   | 0x63                            | Progress                   | CPU DXE Initialization                       |
|             |   | 0x68                            | Progress                   | PCI HB Initialization                        |
|             |   | 0x69                            | Progress                   | NB DXE Initialization                        |
|             |   | 0x6A                            | Progress                   | NB DXE SMM Initialization                    |
|             |   | 0x70                            | Progress                   | SB DXE Initialization                        |
|             | 0x71                                    | Progress                        | SB DXE SMM Initialization  |  |
|             | 0x72                                    | Progress                        | SB DEVICES Initialization  |  |
|             | 0x78                                    | Progress                        | ACPI Module Initialization |  |
|             | 0x79                                    | Progress                        | CSM Initialization         |  |
| 0xD0        | Progress                                | CPU PM Structure Initialization |                            |  |
| Normal boot | BDS(Boot Device Selection) phase        | 0x90                            | Progress                   | BDS started                                  |
|             |   | 0x91                            | Progress                   | Connect device event                         |
|             |   | 0x92                            | Progress                   | PCI Bus Enumeration                          |
|             |   | 0x93                            | Progress                   | PCI Bus Enumeration                          |
|             |   | 0x94                            | Progress                   | PCI Bus Enumeration                          |
|             |   | 0x95                            | Progress                   | PCI Bus Enumeration                          |
|             |   | 0x96                            | Progress                   | PCI Bus Enumeration                          |
|             |   | 0x97                            | Progress                   | Console output connect event                 |
|             |   | 0x98                            | Progress                   | Console input connect event                  |
|             |   | 0x99                            | Progress                   | AMI Super IO start                           |
|             |   | 0x9A                            | Progress                   | AMI USB Driver Initialization                |
|             |   | 0x9B                            | Progress                   | AMI USB Driver Initialization                |
|             |   | 0x9C                            | Progress                   | AMI USB Driver Initialization                |
| 0x9D        | Progress                                | AMI USB Driver Initialization   |                            |  |

(continued on the next page)

| Action      | PHASE                            | POST CODE | TYPE     | DESCRIPTION                        |
|-------------|----------------------------------|-----------|----------|------------------------------------|
| Normal boot | BDS(Boot Device Selection) phase | 0xb2      | Progress | Legacy Option ROM Initialization   |
|             |                                  | 0xb3      | Progress | Reset system                       |
|             |                                  | 0xb4      | Progress | USB hotplug                        |
|             |                                  | 0xb6      | Progress | NVRAM clean up                     |
|             |                                  | 0xb7      | Progress | NVRAM configuration reset          |
|             |                                  | 0xA0      | Progress | IDE, AHCI Initialization           |
|             |                                  | 0xA1      | Progress | IDE, AHCI Initialization           |
|             |                                  | 0xA2      | Progress | IDE, AHCI Initialization           |
|             |                                  | 0xA3      | Progress | IDE, AHCI Initialization           |
|             |                                  | 0x00-0xFF | Progress | Wait BMC ready                     |
|             |                                  | 0xA8      | Progress | BIOS Setup Utility password verify |
|             |                                  | 0xA9      | Progress | BIOS Setup Utility start           |
|             |                                  | 0xAB      | Progress | BIOS Setup Utility input wait      |
|             |                                  | 0xAD      | Progress | Ready to boot event                |
|             |                                  | 0xAE      | Progress | Legacy boot event                  |
|             | Operating system phase           | 0xAA      | Progress | APIC mode                          |
|             |                                  | 0xAC      | Progress | PIC mode                           |

(continued on the next page)

## AMD EPYC™ 7003 Series processors

| Action       | PHASE                                    | POST CODE                                   | TYPE     | DESCRIPTION  |
|--------------|--|---|----------|--|
| SEC Start up | Security Phase                           | 0x01  | Progress | First post code                                    |
|              |  | 0x02  | Progress | Load BSP microcode                                 |
|              |  | 0x03  | Progress | Perform early platform Initialization              |
|              |  | 0x04  | Progress | Set cache as ram for PEI phase                     |
|              |  | 0x05  | Progress | Establish Stack                                    |
|              |  | 0x06  | Progress | CPU Early Initialization                           |
| PSP Boot     | PSP Boot Loader phase (Error Post Codes) | 0x00  | error    | General - Success                                  |
|              |  | 0x01  | error    | Generic Error Code                                 |
|              |  | 0x02  | error    | Generic Memory Error                               |
|              |  | 0x03  | error    | Buffer Overflow                                    |
|              |  | 0x04  | error    | Invalid Parameter(s)                               |
|              |  | 0x05  | error    | Invalid Data Length                                |
|              |  | 0x06  | error    | Data Alignment Error                               |
|              |  | 0x07  | error    | Null Pointer Error                                 |
|              |  | 0x08  | error    | Unsupported Function                               |
|              |  | 0x09  | error    | Invalid Service ID                                 |
|              |  | 0x0A  | error    | Invalid Address                                    |
|              |  | 0x0B  | error    | Out of Resource Error                              |
|              |  | 0x0C  | error    | Timeout  |
|              |  | 0x0D  | error    | data abort exception                               |
|              |  | 0x0E  | error    | prefetch abort exception                           |
|              |  | 0x0F  | error    | Out of Boundary Condition Reached                  |
|              |  | 0x10  | error    | Data corruption                                    |
|              |  | 0x11  | error    | Invalid command                                    |
|              |  | 0x12  | error    | The package type provided by BR is incorrect       |
|              |  | 0x13  | error    | Failed to retrieve FW header during FW validation  |
|              |  | 0x14  | error    | Key size not supported                             |
|              |  | 0x15  | error    | Agesa0 verification error                          |
|              |  | 0x16  | error    | SMU FW verification error                          |
|              |  | 0x17  | error    | OEM SINGING KEY verification error                 |
|              |  | 0x18  | error    | Generic FW Validation error                        |
|              |  | 0x19  | error    | RSA operation fail - bootloader                    |
|              |  | 0x1A  | error    | CCP Passthrough operation failed - internal status |
|              |  | 0x1B  | error    | AES operation fail                                 |
|              |  | 0x1C  | error    | CCP state save failed                              |
|              |  | 0x1D  | error    | CCP state restore failed                           |
| 0x1E         | error                                    | SHA256/384 operation fail - internal status |          |  |
| 0x1F         | error                                    | ZLib Decompression operation fail           |          |  |

(continued on the next page)

| Action   | PHASE                                    | POST CODE   | TYPE  | DESCRIPTION   |
|----------|--|---|-------|---|
| PSP Boot | PSP Boot Loader phase (Error Post Codes) | 0x20  | error | HMAC-SHA256/384 operation fail - internal status    |
|          |  | 0x21  | error | Booted from boot source not recognized by PSP       |
|          |  | 0x22  | error | PSP directory entry not found                       |
|          |  | 0x23  | error | PSP failed to set the write enable latch            |
|          |  | 0x24  | error | PSP timed out because spirom took too long          |
|          |  | 0x25  | error | Cannot find BIOS directory                          |
|          |  | 0x26  | error | SpiRom is not valid                                 |
|          |  | 0x27  | error | slave die has different security state from master  |
|          |  | 0x28  | error | SMI interface init failure                          |
|          |  | 0x29  | error | SMI interface generic error                         |
|          |  | 0x2A  | error | invalid die ID executes MCM related function        |
|          |  | 0x2B  | error | invalid MCM configuration table read from bootrom   |
|          |  | 0x2C  | error | Valid boot mode wasn't detected                     |
|          |  | 0x2D  | error | NVStorage init failure                              |
|          |  | 0x2E  | error | NVStorage generic error                             |
|          |  | 0x2F  | error | MCM 'error' to indicate slave has more data to send |
|          |  | 0x30  | error | MCM error if data size exceeds 32B                  |
|          |  | 0x31  | error | Invalid client id for SVC MCM call                  |
|          |  | 0x32  | error | MCM slave status register contains bad bits         |
|          |  | 0x33  | error | MCM call was made in a single die environment       |
| 0x34     | error                                    | PSP secure mapped to invalid segment (should be 0x400_0000)             |       |   |
| 0x35     | error                                    | No physical x86 cores were found on die                                 |       |   |
| 0x36     | error                                    | Insufficient space for secure OS (range of free SRAM to SVC stack base) |       |   |
| 0x37     | error                                    | SYSHUB mapping memory target type is not supported                      |       |   |
| 0x38     | error                                    | Attempt to unmap permanently mapped TLB to PSP secure region            |       |   |
| 0x39     | error                                    | Unable to map an SMN address to AXI space                               |       |   |

*(continued on the next page)*

| Action   | PHASE                                    | POST CODE  | TYPE  | DESCRIPTION  |
|----------|--|--|-------|--|
| PSP Boot | PSP Boot Loader phase (Error Post Codes) | 0x3A   | error | Unable to map a SYSHUB address to AXI space                                |
|          |  | 0x3B   | error | The count of CCXs or cores provided by bootrom is not consistent           |
|          |  | 0x3C   | error | Uncompressed image size doesn't match value in compressed header           |
|          |  | 0x3D   | error | Compressed option used in case where not supported                         |
|          |  | 0x3E   | error | Fuse info on all dies don't match  |
|          |  | 0x3F   | error | PSP sent message to SMU; SMU reported an error                             |
|          |  | 0x40   | error | Function RunPostX86ReleaseUnitTests failed in memcmp()                     |
|          |  | 0x41   | error | Interface between PSP to SMU not available.                                |
|          |  | 0x42   | error | Timer wait parameter too large   |
|          |  | 0x43   | error | Test harness module reported an error                                      |
|          |  | 0x44   | error | x86 wrote C2PMSG_0 interrupting PSP, but the command has an invalid format |
|          |  | 0x45   | error | Failed to read from SPI the Bios Directory or Bios Combo Directory         |
|          |  | 0x46   | error | Mini-BL, validation of the PSP SRAM image failed on HMAC compare           |
|          |  | 0x47   | error | Failed to read the combo bios header                                       |
|          |  | 0x48   | error | Potential stack corruption in jump to Mini BL                              |
|          |  | 0x49   | error | Error in Validate and Loading AGESA APOB SVC call                          |
|          |  | 0x4A   | error | Correct fuse bits for DIAG_BL loading not set                              |
|          |  | 0x4B   | error | The UmcProgramKeys() function was not called by AGESA                      |
|          |  | 0x4C   | error | Unconditional Unlock based on serial numbers failure                       |
|          |  | 0x4D   | error | Syshub register programming mismatch during readback                       |
|          |  | 0x4E   | error | Family ID in MP0_SFUSE_SEC[7:3] not correct                                |
|          |  | 0x4F   | error | An operation was invoked that can only be performed by the GM              |
|          |  | 0x50   | error | Failed to acquire host controller semaphore to claim ownership of SMB      |
|          |  | 0x51   | error | Timed out waiting for host to complete pending transactions                |
|          |  | 0x52   | error | Timed out waiting for slave to complete pending transactions               |
|          |  | 0x53   | error | Unable to kill current transaction on host, to force idle                  |
|          |  | 0x54   | error | One of: Illegal command, Unclaimed cycle, or Host time out                 |
|          |  | 0x55   | error | An smbus transaction collision detected, operation restarted               |
|          |  | 0x56   | error | Transaction failed to be started or processed by host, or not completed    |
|          |  | 0x57   | error | An unsolicited smbus interrupt was received                                |
|          |  | 0x58   | error | An attempt to send an unsupported PSP-SMU message was made                 |
|          |  | 0x59   | error | An error/data corruption detected on response from SMU for sent msg        |
| 0x5A     | error                                    | MCM Steady-state unit test failed                            |       |  |
| 0x5B     | error                                    | S3 Enter failed  |       |  |
| 0x5C     | error                                    | AGESA BL did not set PSP SMU reserved addresses via SVC call |       |  |
| 0x5E     | error                                    | CcxSecBisiEn not set in fuse RAM                             |       |  |
| 0x5F     | error                                    | Received an unexpected result                                |       |  |

(continued on the next page)

| Action   | PHASE                                    | POST CODE                               | TYPE  | DESCRIPTION   |
|----------|--|---|-------|---|
| PSP Boot | PSP Boot Loader phase (Error Post Codes) | 0x60                                    | error | VMG Storage Init failed   |
|          |  | 0x61                                    | error | failure in mbedTLS user app   |
|          |  | 0x62                                    | error | An error occurred whilst attempting to SMN map a fuse register              |
|          |  | 0x63                                    | error | Fuse burn sequence/operation failed due to internal SOC error               |
|          |  | 0x64                                    | error | Fuse sense operation timed out  |
|          |  | 0x65                                    | error | Fuse burn sequence/operation timed out waiting for burn done                |
|          |  | 0x66                                    | error | The PMU FW Public key certificate loading or authentication fails           |
|          |  | 0x67                                    | error | This PSP FW was revoked   |
|          |  | 0x68                                    | error | The platform model/vendor id fuse is not matching the BIOS public key token |
|          |  | 0x69                                    | error | The BIOS OEM public key of the BIOS was revoked for this platform           |
|          |  | 0x6A                                    | error | PSP level 2 directory not match expected value.                             |
|          |  | 0x6B                                    | error | BIOS level 2 directory not match expected value.                            |
|          |  | 0x6C                                    | error | Reset image not found   |
|          |  | 0x6D                                    | error | Generic error indicating the CCP HAL initialization failed                  |
|          |  | 0x6E                                    | error | failure to copy NVRAM to DRAM.  |
|          |  | 0x6F                                    | error | Invalid key usage flag  |
|          |  | 0x71                                    | error | RSMU signaled a security violation  |
|          |  | 0x72                                    | error | Error programming the WAFL PCS registers                                    |
|          |  | 0x73                                    | error | Error setting wafl PCS threshold value                                      |
|          |  | 0x74                                    | error | Error loading OEM trustlets   |
|          |  | 0x75                                    | error | Recovery mode across all dies is not sync'd                                 |
|          |  | 0x76                                    | error | Uncorrectable WAFL error detected   |
|          |  | 0x77                                    | error | Fatal MP1 error detected  |
| 0x78     | error                                    | Bootloader failed to find OEM signature |       |   |
| 0x79     | error                                    | Error copying BIOS to DRAM              |       |   |
| 0x7A     | error                                    | Error validating BIOS image signature   |       |   |

*(continued on the next page)*

| Action   | PHASE                                     | POST CODE  | TYPE  | DESCRIPTION   |
|----------|---|--|-------|---|
| PSP Boot | PSP Boot Loader phase (Status Post Codes) | 0x7B   | error |   |
|          |   | 0x7C   | error | Platform Vendor ID and/or Model ID binding violation  |
|          |   | 0x7D   | error | Bootloader detects BIOS request boot from SPI-ROM, which is unsupported for PSB.                    |
|          |   | 0x7E   | error | Requested fuse is already blown, reblow will cause ASIC malfunction                                 |
|          |   | 0x7F   | error | Error with actual fusing operation  |
|          |   | 0x80   | error | (Local Master PSP on P1 socket) Error reading fuse info   |
|          |   | 0x81   | error | (Local Master PSP on P1 socket) Platform Vendor ID and/or Model ID binding violation                |
|          |   | 0x82   | error | (Local Master PSP on P1 socket) Requested fuse is already blown, reblow will cause ASIC malfunction |
|          |   | 0x83   | error | (Local Master PSP on P1 socket) Error with actual fusing operation                                  |
|          |   | 0x84   | error | SEV FW Rollback attempt is detected   |
|          |   | 0x85   | error | / SEV download FW command fail to broadcast and clear the IsInSRAM field on slave dies              |
|          |   | 0x86   | error | Agesa error injection failure   |
|          |   | 0x87   | error | Uncorrectable TWIX error detected   |
|          |   | 0x88   | error | Error programming the TWIX PCS registers  |
|          |   | 0x89   | error | Error setting TWIX PCS threshold value  |
|          |   | 0x8A   | error | SW CCP queue is full, cannot add more entries   |
|          |   | 0x8B   | error | CCP command description syntax error detected from input  |
|          |   | 0x8C   | error | Return value stating that the command has not yet been scheduled                                    |
|          |   | 0x8D   | error | The command is scheduled and being worked on  |
|          |   | 0x8E   | error | The DXIO PHY SRAM Public key certificate loading or authentication fails                            |
|          |   | 0x8F   | error | fTPM binary size exceeds limit allocated in Private DRAM, need to increase the limit                |
|          |   | 0x90   | error | The TWIX link for a particular CCD is not trained Fatal error                                       |
|          |   | 0x91   | error | Security check failed (not all dies are in same security state)                                     |
|          |   | 0x92   | error | FW type mismatch between the requested FW type and the FW type embedded in the FW binary header     |
|          |   | 0x93   | error | SVC call input parameter address violation  |
|          |   | 0x94   | error | Knoll failed to idle correctly after being reset  |
|          |   | 0x95   | error | Bad status returned by I2CKnollCheck  |
|          |   | 0x96   | error | NACK to general call (no device on Knoll I2C bus)   |
|          |   | 0x97   | error | Null pointer passed to I2CKnollCheck  |
|          |   | 0x98   | error | Invalid device-ID found during Knoll authentication   |
|          |   | 0x99   | error | Error during Knoll/Prom key derivation  |
|          |   | 0x9A   | error | Null pointer passed to Crypto function  |
| 0x9B     | error                                     | Error in checksum from wrapped Knoll/Prom keys   |       |   |
| 0x9C     | error                                     | Knoll returned an invalid response to a command  |       |   |
| 0x9D     | error                                     | Bootloader failed in Knoll Send Command function |       |   |
| 0x9E     | error                                     | No Knoll device found by verifying MAC           |       |   |
| 0x9F     | error                                     | The maximum allowable error post code            |       |   |

(continued on the next page)

| Action    | PHASE                                   | POST CODE | TYPE     | DESCRIPTION                                  |
|-----------|---|-----------|----------|--|
| Quick VGA | PEI(Pre-EFI Initialization) phase       | 0x10      | Progress | PEI Core Entry                               |
|           |   | 0x11      | Progress | PEI cache as ram CPU initial                 |
|           |   | 0x15      | Progress | NB Initialization before installed memory    |
|           |   | 0x19      | Progress | SB Initialization before installed memory    |
|           | DXE(Driver Execution Environment) phase | 0x32      | Progress | CPU POST-Memory Initialization               |
|           |   | 0x33      | Progress | CPU Cache Initialization                     |
|           |   | 0x34      | Progress | Application Processor(s) (AP) Initialization |
|           |   | 0x35      | Progress | BSP Selection                                |
|           |   | 0x36      | Progress | CPU Initialization                           |
|           |   | 0x37      | Progress | Pre-memory NB Initialization                 |
|           |   | 0x3B      | Progress | Pre-memory SB Initialization                 |
|           |   | 0x4F      | Progress | DXE Initial Program Load(IPL)                |
|           |   | 0x60      | Progress | DXE Core Started                             |
|           |   | 0x61      | Progress | DXE NVRAM Initialization                     |
|           |   | 0x62      | Progress | SB run-time Initialization                   |
|           |   | 0x63      | Progress | CPU DXE Initialization                       |
|           |   | 0x68      | Progress | PCI HB Initialization                        |
|           |   | 0x69      | Progress | NB DXE Initialization                        |
|           |   | 0x6A      | Progress | NB DXE SMM Initialization                    |
|           |   | 0x70      | Progress | SB DXE Initialization                        |
|           |   | 0x71      | Progress | SB DXE SMM Initialization                    |
|           |   | 0x72      | Progress | SB DEVICES Initialization                    |
|           |   | 0x78      | Progress | ACPI Module Initialization                   |
|           |   | 0x79      | Progress | CSM Initialization                           |
|           |   | 0xD0      | Progress | CPU PM Structure Initialization              |

*(continued on the next page)*

| Action      | PHASE                            | POST CODE              | TYPE              | DESCRIPTION                        |
|-------------|----------------------------------|------------------------|-------------------|------------------------------------|
| Normal boot | BDS(Boot Device Selection) phase | 0x90                   | Progress          | BDS started                        |
|             |                                  | 0x91                   | Progress          | Connect device event               |
|             |                                  | 0x92                   | Progress          | PCI Bus Enumeration                |
|             |                                  | 0x93                   | Progress          | PCI Bus Enumeration                |
|             |                                  | 0x94                   | Progress          | PCI Bus Enumeration                |
|             |                                  | 0x95                   | Progress          | PCI Bus Enumeration                |
|             |                                  | 0x96                   | Progress          | PCI Bus Enumeration                |
|             |                                  | 0x97                   | Progress          | Console output connect event       |
|             |                                  | 0x98                   | Progress          | Console input connect event        |
|             |                                  | 0x99                   | Progress          | AMI Super IO start                 |
|             |                                  | 0x9A                   | Progress          | AMI USB Driver Initialization      |
|             |                                  | 0x9B                   | Progress          | AMI USB Driver Initialization      |
|             |                                  | 0x9C                   | Progress          | AMI USB Driver Initialization      |
|             |                                  | 0x9D                   | Progress          | AMI USB Driver Initialization      |
|             |                                  | 0xb2                   | Progress          | Legacy Option ROM Initialization   |
|             |                                  | 0xb3                   | Progress          | Reset system                       |
|             |                                  | 0xb4                   | Progress          | USB hotplug                        |
|             |                                  | 0xb6                   | Progress          | NVRAM clean up                     |
|             |                                  | 0xb7                   | Progress          | NVRAM configuration reset          |
|             |                                  | 0xA0                   | Progress          | IDE, AHCI Initialization           |
|             |                                  | 0xA1                   | Progress          | IDE, AHCI Initialization           |
|             |                                  | 0xA2                   | Progress          | IDE, AHCI Initialization           |
|             |                                  | 0xA3                   | Progress          | IDE, AHCI Initialization           |
|             |                                  | 0x00-0xFF              | Progress          | Wait BMC ready                     |
|             |                                  | 0xA8                   | Progress          | BIOS Setup Utility password verify |
|             |                                  | 0xA9                   | Progress          | BIOS Setup Utility start           |
|             |                                  | 0xAB                   | Progress          | BIOS Setup Utility input wait      |
|             |                                  | 0xAD                   | Progress          | Ready to boot event                |
|             | 0xAE                             | Progress               | Legacy boot event |                                    |
|             |                                  | Operating system phase | 0xAA              | Progress                           |
|             | 0xAC                             |                        | Progress          | PIC mode                           |

# Hardware Information

# 2

This chapter lists the hardware setup procedures that you have to perform when installing or removing system components.

## 2.1 Chassis cover

### Removing the rear cover

1. Remove the two (2) screws on both sides of the rear cover with a Phillips screwdriver.

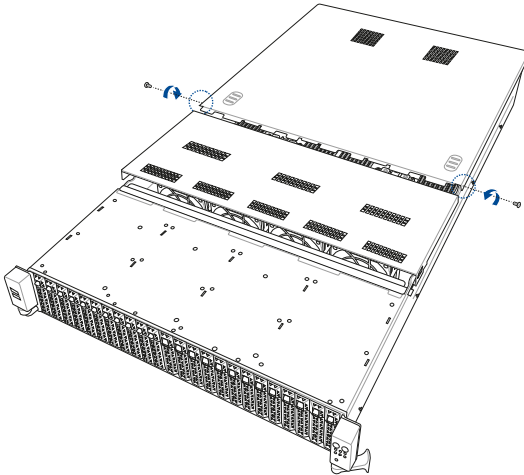

2. Push the buttons on both sides to release the rear cover from the chassis.
3. Slide the rear cover towards the rear panel to disengage it from the chassis.
4. Lift the rear cover from the chassis.

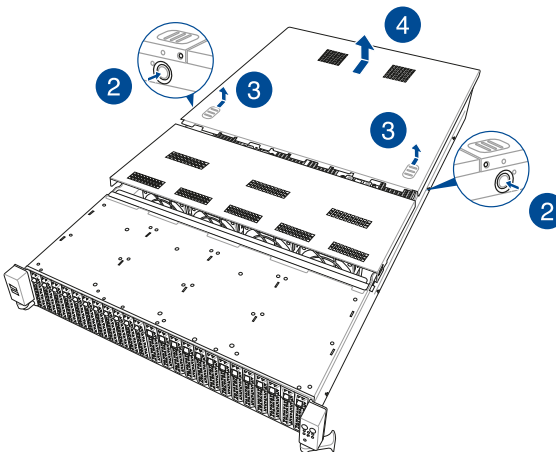

## Removing the mid cover

1. Remove the two (2) screws on both sides of the mid cover with a Phillips screwdriver.

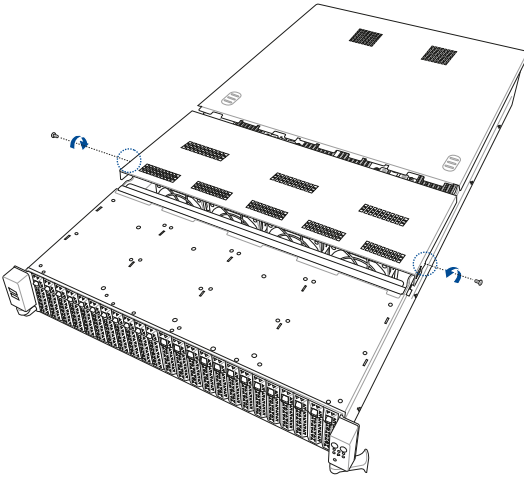

2. Push the buttons on both sides to release the mid cover from the chassis.
3. Slide the mid cover towards the rear panel to disengage it from the chassis.
4. Lift the mid cover from the chassis.

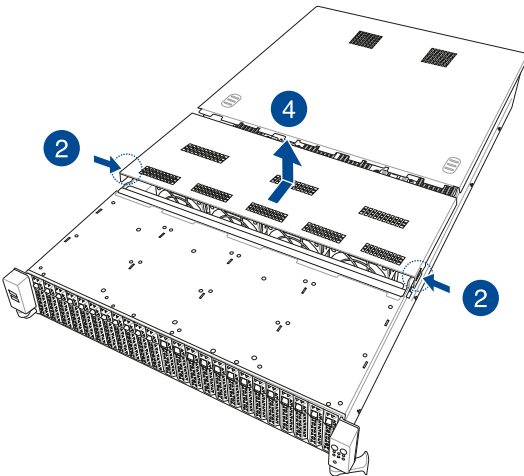

## 2.2 Air ducts

### 24 NVMe non-GPU model

To remove the air ducts:

1. Remove the two (2) screws from the chassis.
2. Gently lift the air ducts vertically out of the chassis.

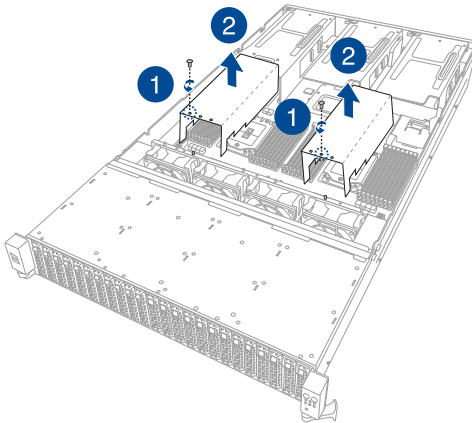

To install the air ducts:

1. Align the air ducts along the edges of the DIMM slots, then place the air ducts in the chassis, and ensure they are fitted firmly into the chassis.
2. Secure the air ducts to the chassis with the two (2) screws.

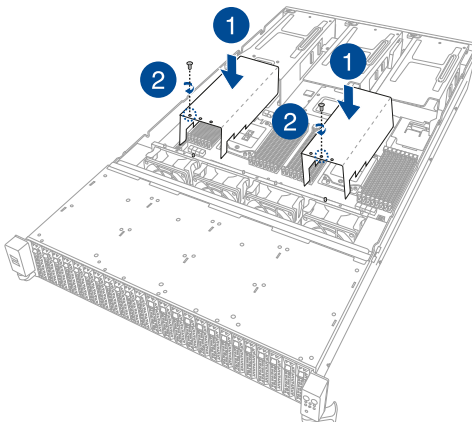

## 12 NVMe GPU model

To remove the air ducts:

1. Remove the four (4) screws from the chassis.

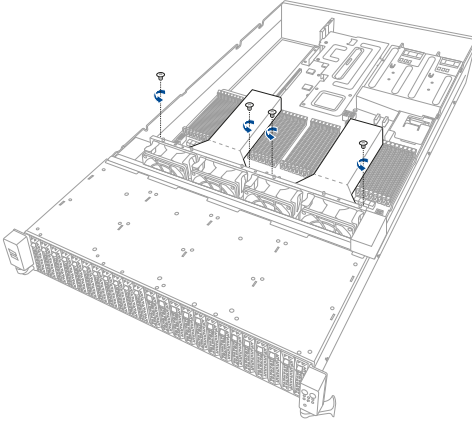

2. Gently lift the air ducts vertically out of the chassis.

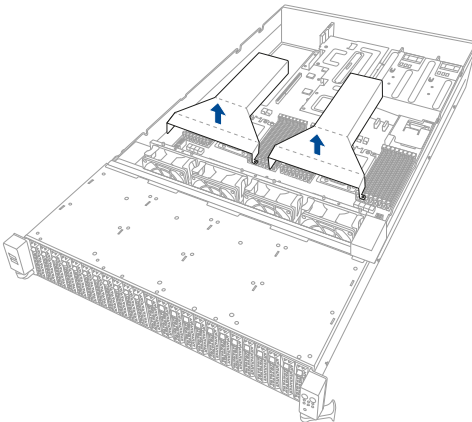

To install the air ducts:

1. Align the air ducts along the edges of the DIMM slots, then place the air ducts in the chassis, and ensure they are fitted firmly into the chassis.

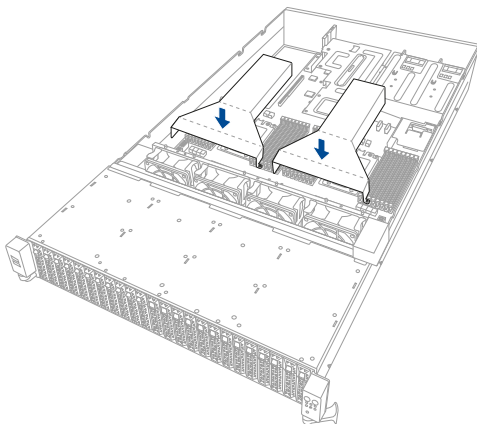

2. Secure the air ducts to the chassis with the four (4) screws.

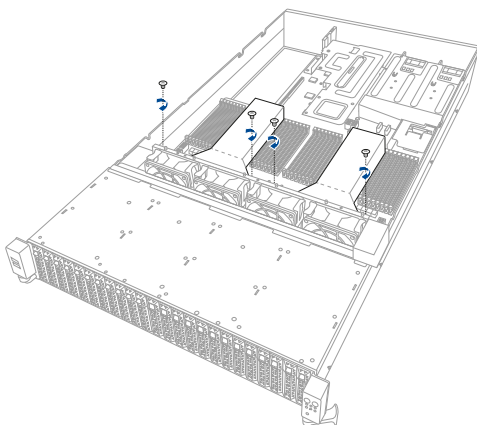

## 2.3 Central Processing Unit (CPU)

The motherboard comes with a surface mount Socket SP3 designed for the AMD EPYC™ 7002 Series.



- Upon purchase of the motherboard, ensure that the PnP cap is on the socket and the socket contacts are not bent. Contact your retailer immediately if the PnP cap is missing, or if you see any damage to the PnP cap/socket contacts/motherboard components. ASUS will shoulder the cost of repair only if the damage is shipment/transit-related.
- Keep the cap after installing the motherboard. ASUS will process Return Merchandise Authorization (RMA) requests only if the motherboard comes with the cap on the Socket SP3.
- The product warranty does not cover damage to the socket contacts resulting from incorrect CPU installation/removal, or misplacement/loss/incorrect removal of the PnP cap.

### 2.3.1 Installing the CPU and heatsink

To install the CPU and heatsink:

1. Remove the rear cover. For more information, see the section **Chassis cover**.
2. Remove the air ducts. For more information, see the section **Air ducts**.
3. Loosen each screw one by one in the sequence shown on the socket to open the load plate.

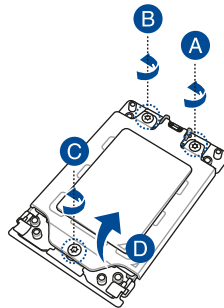

- 4. Slightly lift open the rail frame.

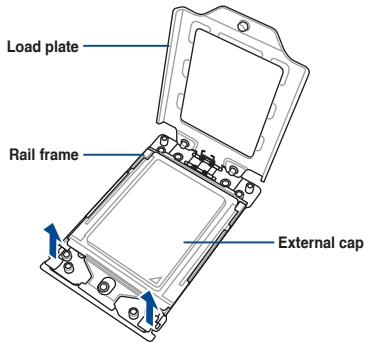

- 5. Slide the external cap out of the rail frame.

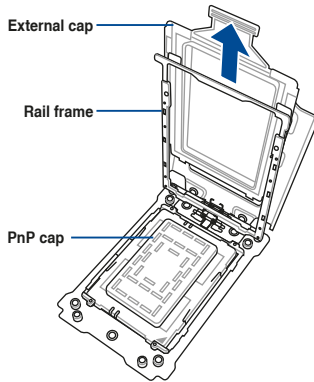

- 6. Slide the carrier frame with CPU into the rail frame, then remove the PnP cap.



The carrier frame with CPU fits in only one correct orientation. DO NOT force the carrier frame with CPU into the rail frame.

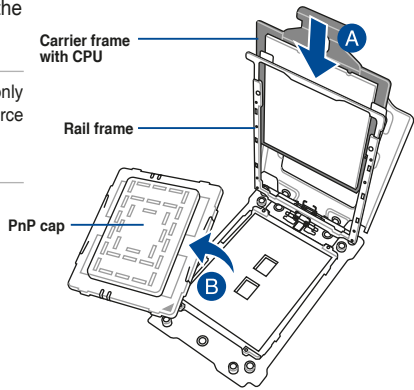

7. Gently push the rail frame just enough to let it sit on top of the CPU socket.

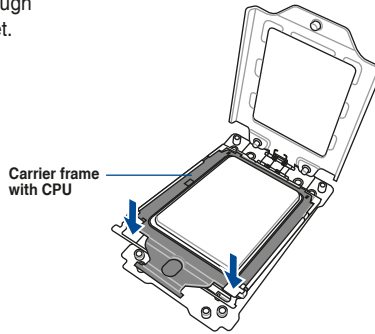

8. Close the load plate just enough to let it sit on top of the CPU, then secure each screw one by one in the sequence shown on the socket to completely secure the load plate.



The load plate screws are T20 models. A torque value of  $16.1 \pm 1.2$  kgf-cm ( $14.0 \pm 1.0$  lbf-in) is recommended.

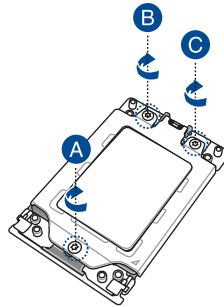

9. Twist each of the four screws with a screwdriver just enough to attach the heatsink to the motherboard. When the four screws are attached, tighten them one by one in the sequence shown in the illustration to completely secure the heatsink.



The heatsink screws are T20 models. A torque value of  $16.1 \pm 1.2$  kgf-cm ( $14.0 \pm 1.0$  lbf-in) is recommended.

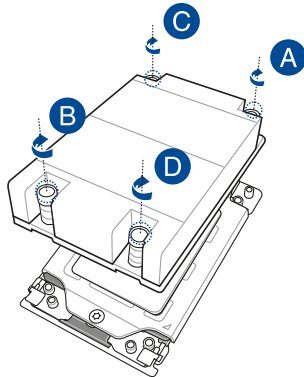

10. Reinstall the air ducts to complete the CPU and heatsink installation. For more information, refer to section **Air ducts**.

## 2.4 System memory

### 2.4.1 Overview

The motherboard comes with 32 Double Data Rate 4 (DDR4) Dual Inline Memory Modules (DIMM) sockets.

The figure illustrates the location of the DDR4 DIMM sockets:

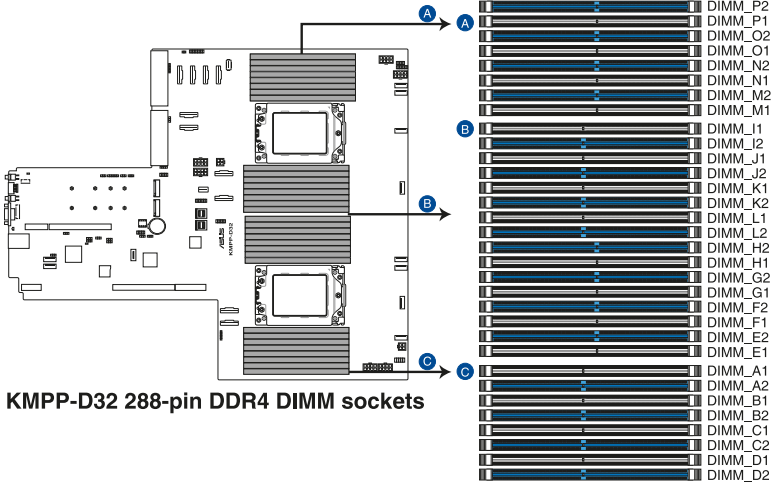

## 2.4.2 Memory Configurations

You may install 16GB, 32GB, and 64GB RDIMMs into the DIMM sockets. If you are not sure on which slots to install the DIMMS, you can use the recommended memory configuration in this section for reference.



- Refer to ASUS Server AVL for the updated list of compatible DIMMs.
- Always install DIMMs with the same CAS latency. For optimum compatibility, it is recommended that you obtain memory modules from the same vendor.
- Start installing the DIMMs into the second slots (such as DIMM\_A2 , DIMM\_B2, etc.)

| Recommended dual CPU configuration |       |   |   |    |    |
|------------------------------------|-------|---|---|----|----|
|                                    | DIMMs |   |   |    |    |
|                                    | 2     | 4 | 8 | 16 | 32 |
| DIMM_P2                            |       |   | • | •  | •  |
| DIMM_P1                            |       |   |   |    | •  |
| DIMM_O2                            |       |   | • | •  | •  |
| DIMM_O1                            |       |   |   |    | •  |
| DIMM_N2                            |       |   |   | •  | •  |
| DIMM_N1                            |       |   |   |    | •  |
| DIMM_M2                            |       |   |   | •  | •  |
| DIMM_M1                            |       |   |   |    | •  |
| DIMM_I1                            |       |   |   |    | •  |
| DIMM_I2                            |       |   |   | •  | •  |
| DIMM_J1                            |       |   |   |    | •  |
| DIMM_J2                            |       |   |   | •  | •  |
| DIMM_K1                            |       |   |   |    | •  |
| DIMM_K2                            | •     | • | • | •  | •  |
| DIMM_L1                            |       |   |   |    | •  |
| DIMM_L2                            |       | • | • | •  | •  |
| DIMM_H2                            |       |   | • | •  | •  |
| DIMM_H1                            |       |   |   |    | •  |
| DIMM_G2                            |       |   | • | •  | •  |
| DIMM_G1                            |       |   |   |    | •  |
| DIMM_F2                            |       |   |   | •  | •  |
| DIMM_F1                            |       |   |   |    | •  |
| DIMM_E2                            |       |   |   | •  | •  |
| DIMM_E1                            |       |   |   |    | •  |
| DIMM_A1                            |       |   |   |    | •  |
| DIMM_A2                            |       |   |   | •  | •  |
| DIMM_B1                            |       |   |   |    | •  |
| DIMM_B2                            |       |   |   | •  | •  |
| DIMM_C1                            |       |   |   |    | •  |
| DIMM_C2                            | •     | • | • | •  | •  |
| DIMM_D1                            |       |   |   |    | •  |
| DIMM_D2                            |       | • | • | •  | •  |

## 2.4.3 Installing a DIMM on a single clip DIMM socket



Ensure to unplug the power supply before adding or removing DIMMs or other system components. Failure to do so may cause severe damage to both the motherboard and the components.

1. Unlock a DIMM socket by pressing the retaining clip outward.
2. Align a DIMM on the socket such that the notch on the DIMM matches the DIMM slot key on the socket.

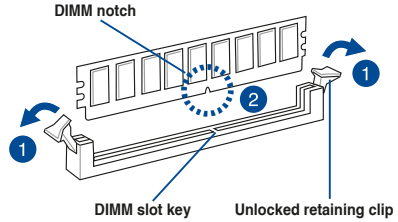

A DIMM is keyed with a notch so that it fits in only one direction. DO NOT force a DIMM into a socket in the wrong direction to avoid damaging the DIMM.

3. Hold the DIMM by both of its ends then insert the DIMM vertically into the socket. Apply force to both ends of the DIMM simultaneously until the retaining clips snaps back into place.

Ensure that the DIMM is sitting firmly on the DIMM slot.

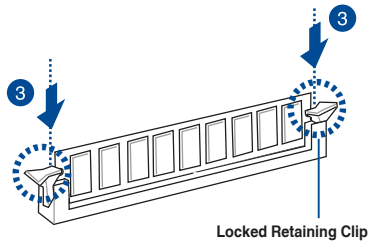

Always insert the DIMM into the socket vertically to prevent DIMM notch damage.

## 2.4.4 Removing a DIMM

1. Remove the top cover. For more information, see the section 2.1 **Chassis cover**.
2. Simultaneously press the retaining clips outward to unlock the DIMM.
3. Remove the DIMM from the socket.

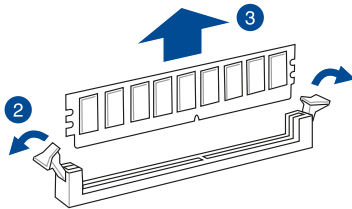

Support the DIMM lightly with your fingers when pressing the retaining clips. The DIMM might get damaged when it flips out with extra force.

## 2.5 Storage devices

The system supports twenty-four (24) 2.5" hot-swap SATA/SAS/NVMe storage devices (up to 8 x NVMe/SATA/SAS + 16 x NVMe). The storage device installed on the storage device tray connects to the motherboard SATA/SAS/NVMe ports via the SATA/SAS/NVMe backplane.

### 24 x NVMe

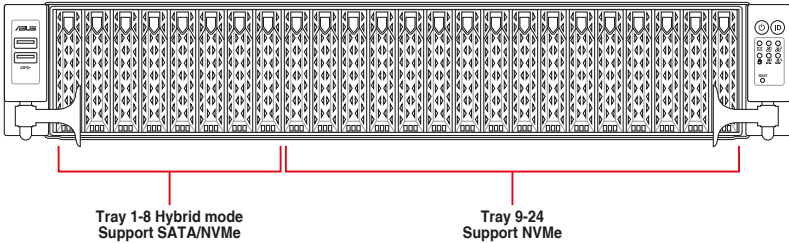

- Select Pike/Storage card for additional SATA/SAS support on Tray 9-24.
- **CPU 1 Support:** 8 x SATA/SAS (Tray1-8) + 4 x NVMe (Tray9-12) or 12 x NVMe (Tray11-12).
- **CPU 2 Support:** 12 x NVMe (Tray13-24).

### 12 x NVMe

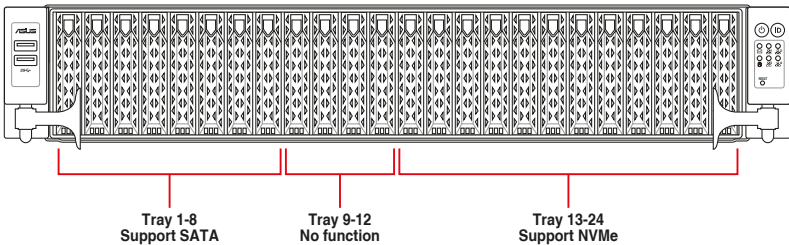

- Select Pike/Storage card for additional SATA/SAS support on Tray 9-24.
- **CPU 1 Support:** 8 x SATA (Tray1-8).
- **CPU 2 Support:** 12 x NVMe (Tray13-24).

To install a 2.5" hot-swap SATA/SAS/NVMe storage device:

1. Press the spring lock then pull the tray lever outward to release the storage device tray. The storage device tray ejects slightly after you pull out the lever.
2. Firmly hold the tray lever and pull the storage device tray out of the bay.

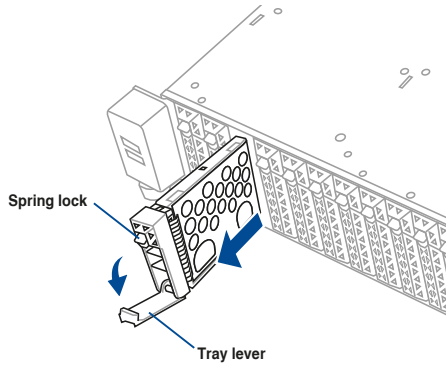

3. Prepare the 2.5" storage device and the bundled set of screws.
4. Place the 2.5" storage device into the storage device tray then secure it with four screws.

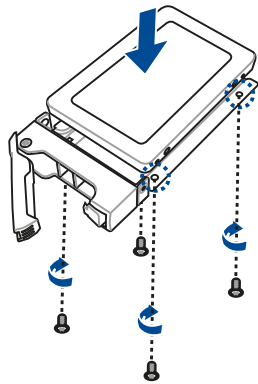

5. Push the storage device tray and storage device assembly all the way into the depth of the bay until the tray lever and spring lock clicks and secures the storage device tray in place.

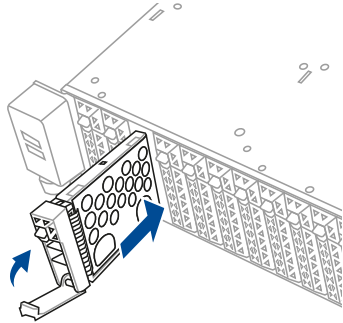

- 
- When installed, the SATA/SAS/NVMe connector on the storage device connects to the SATA/SAS/NVMe interface on the backplane.
  - The storage device tray is correctly placed when its front edge aligns with the bay edge.
- 

6. Repeat steps 1 to 5 to install the other SATA/SAS/NVMe storage devices.

## 2.6 Expansion slot

The barebone server comes with four pre-installed riser cards to support eight PCIe slots and one OCP Mezzanine slot on board.

### Standard model / GPU model

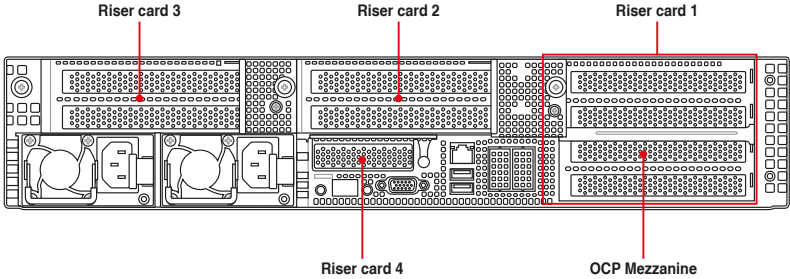

### Standard model with rear bay

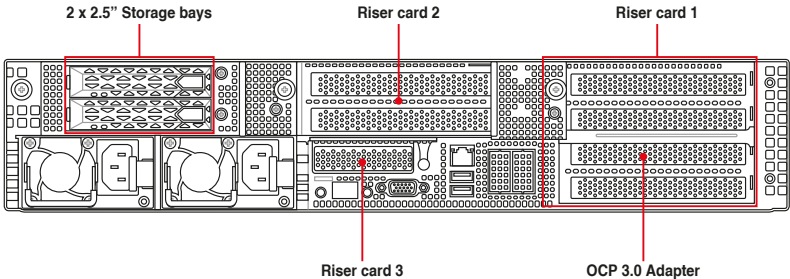

## 2.6.1 Installing an expansion card to riser card bracket 1

To install an expansion card to the riser card bracket 1:

1. Loosen the thumbscrew securing the riser card bracket to the chassis.
2. Lift the riser card out of the chassis by firmly holding it by the tab and pulling it upwards to detach it from the PCIe slot on the motherboard.

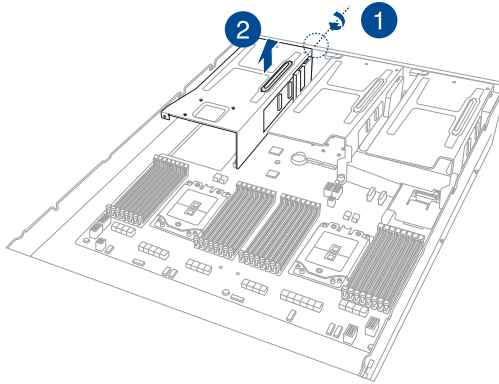

3. Remove the cable from the riser card bracket.

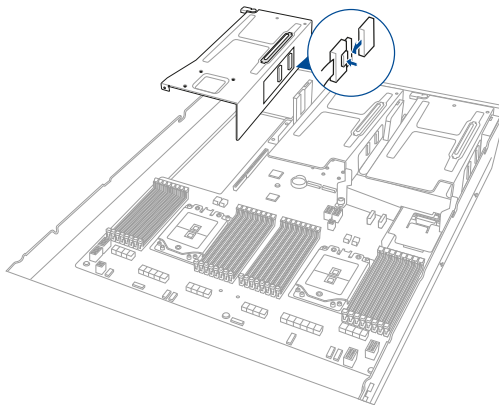

4. Place the riser card bracket on a flat and stable surface in the orientation as shown.
5. Flip the metal bracket lock open.

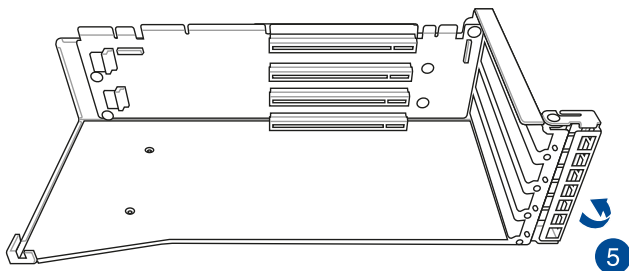

6. Install the PCIE expansion card into the riser card bracket.
7. Flip the metal bracket lock back to secure the PCIE expansion card to the riser card bracket.

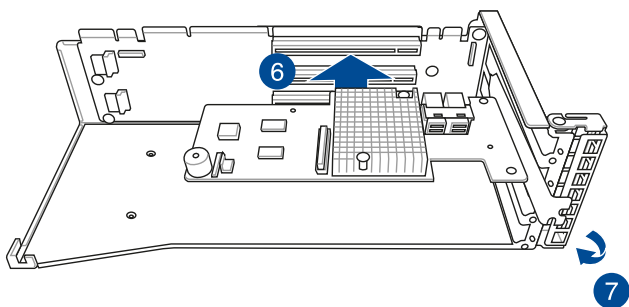

8. Reconnect the cable to the riser card bracket.

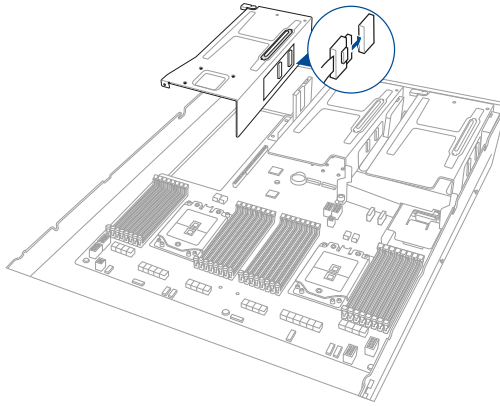

9. Reinstall the riser card to the motherboard.
10. Secure the riser card bracket to the chassis with the thumbscrew.

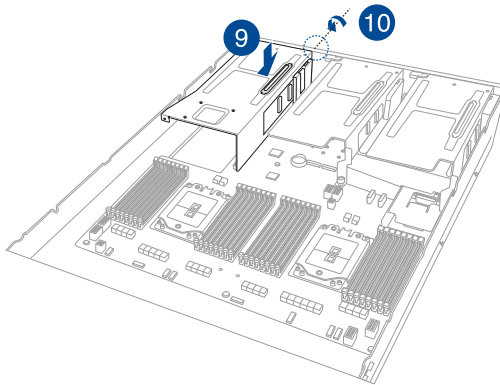

## 2.6.2 Installing an expansion card to riser card bracket 2

To install an expansion card on the riser card bracket 2:

1. Loosen the thumbscrew securing the riser card bracket to the chassis.
2. Loosen the thumbscrew securing the riser card to the motherboard.
3. Lift the riser card out of the chassis by firmly holding it by the tab and pulling it upwards to detach it from the PCIe slot on the motherboard.

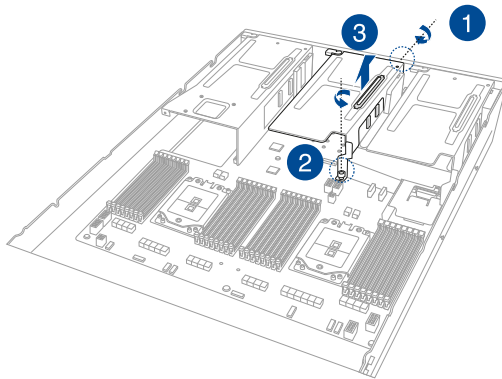

4. Remove the cable from the riser card bracket.

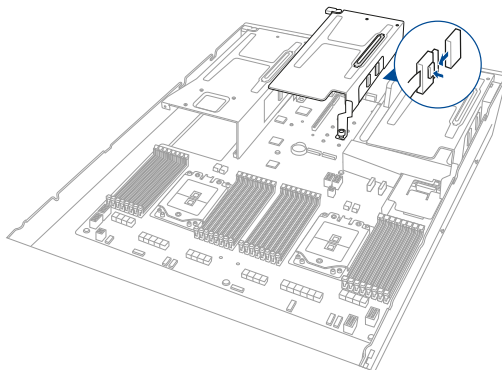

5. Place the riser card bracket on a flat and stable surface in the orientation as shown.
6. Flip the metal bracket lock open.

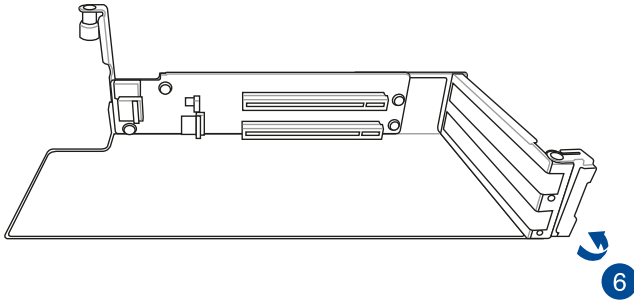

7. Install the PCIe expansion card into the riser card bracket.
8. Flip the metal bracket lock back to secure the PCIe expansion card to the riser card bracket.

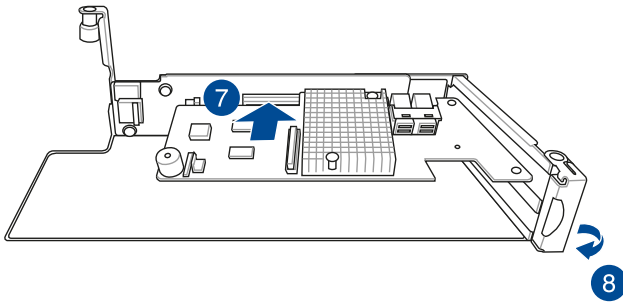

9. Reconnect the cable to the riser card bracket.

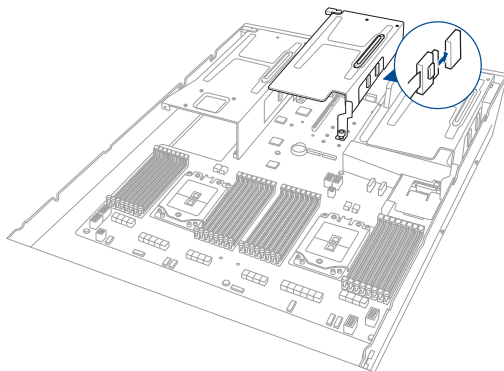

10. Reinstall the riser card to the motherboard.
11. Secure the riser card bracket to the chassis with the thumbscrew.
12. Secure the riser card to the motherboard with the thumbscrew.

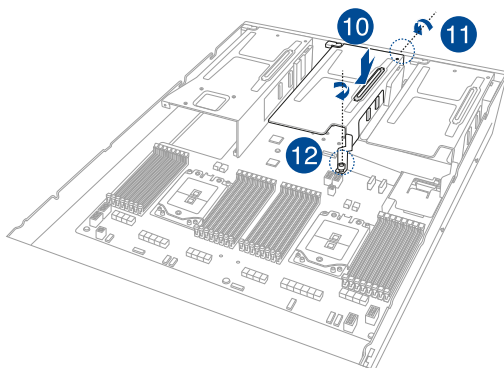

### 2.6.3 Installing an expansion card to riser card bracket 3

To install an expansion card on the riser card bracket 3:

1. Loosen the thumbscrew securing the riser card bracket to the chassis.
2. Loosen the thumbscrew securing the riser card to the motherboard.
3. Lift the riser card out of the chassis by firmly holding it by the tab and pulling it upwards to detach it from the PCIe slot on the motherboard.

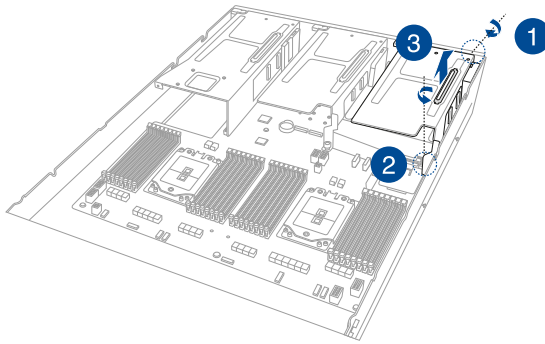

4. Remove the cable from the riser card bracket.

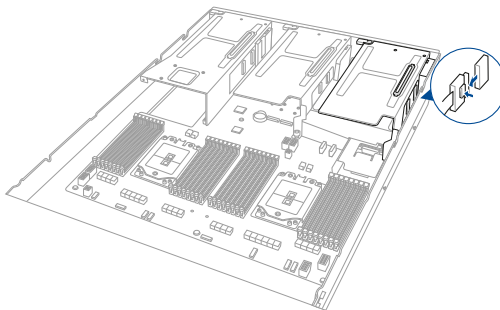

5. Place the riser card bracket on a flat and stable surface in the orientation as shown.
6. Flip the metal bracket lock open.

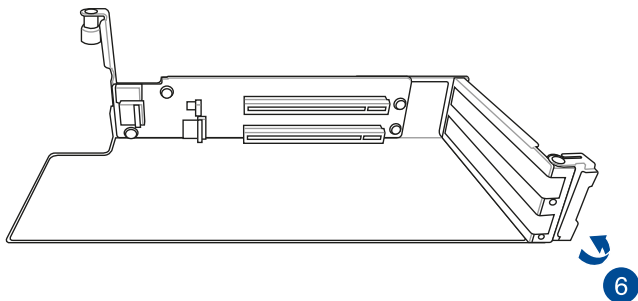

7. Install the PCIE expansion card into the riser card bracket.
8. Flip the metal bracket lock back to secure the PCIE expansion card to the riser card bracket.

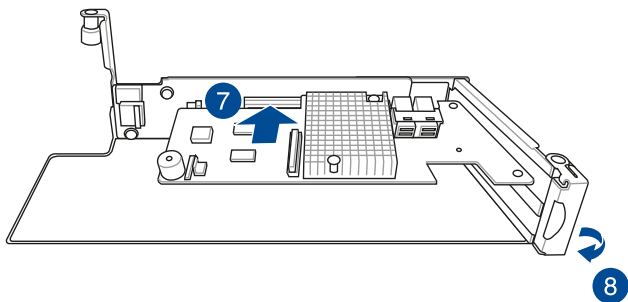

9. Reconnect the cable to the riser card bracket.

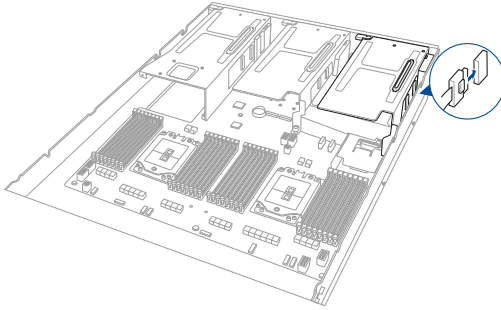

10. Reinstall the riser card to the motherboard.
11. Secure the riser card bracket to the chassis with the thumbscrew.
12. Secure the riser card to the motherboard with the thumbscrew.

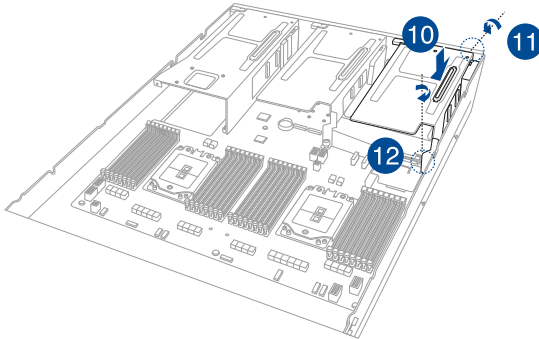

## 2.6.4 Installing an expansion card to riser card bracket 4

To install an expansion card to the riser card bracket 4:

1. Loosen the thumbscrew securing the riser card bracket to the chassis.
2. Lift the riser card out of the chassis by firmly holding it by the tab and pulling it upwards to detach it from the PCIe slot on the motherboard.

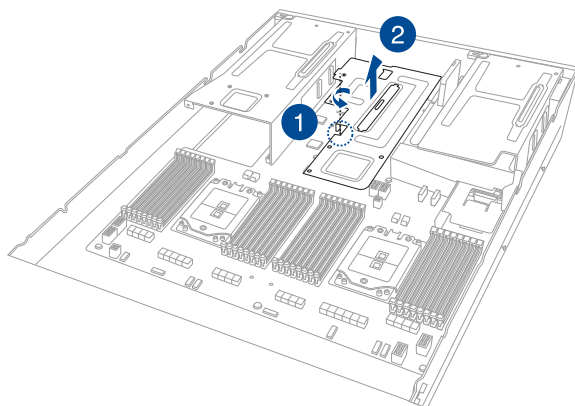

3. Flip the riser card bracket over and remove metal bracket.

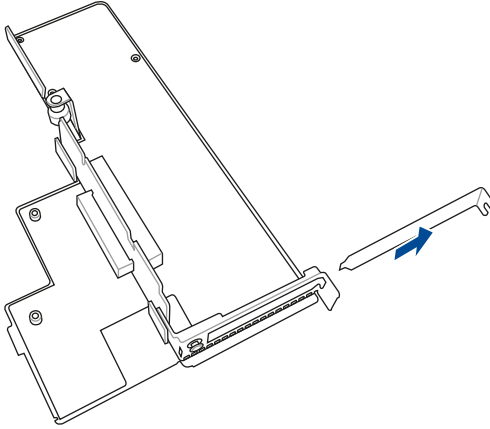

4. Install the expansion card to your riser card bracket.

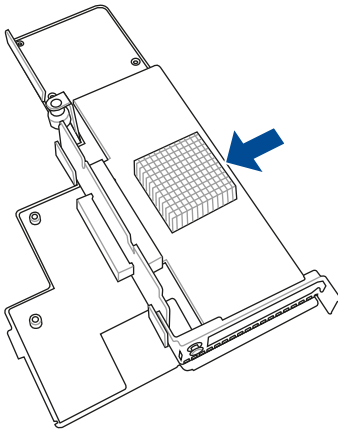

5. Reinstall the riser card to the motherboard.
6. Secure the riser card bracket to the chassis with the thumbscrew.

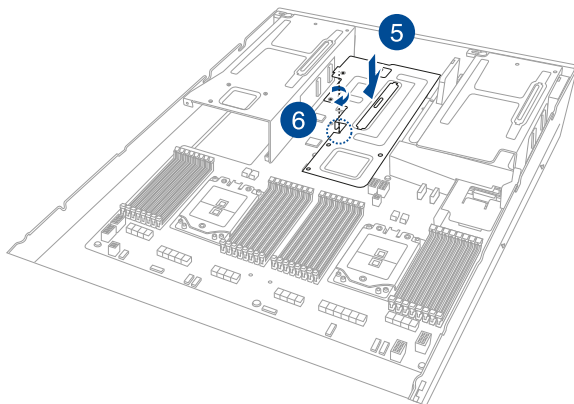

## 2.6.5 Installing an OCP 3.0 slot baseboard and OCP 3.0 card to the riser card bracket



We recommend you install the OCP 3.0 slot baseboard to the PCIe2 slot on the riser card bracket 1.

1. Loosen the thumbscrew securing the riser card bracket to the chassis.
2. Lift the riser card out of the chassis by firmly holding it by the tab and pulling it upwards to detach it from the PCIe slot on the motherboard.

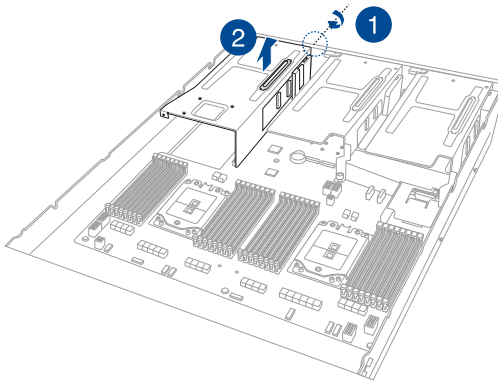

3. Remove the cable from the riser card bracket.

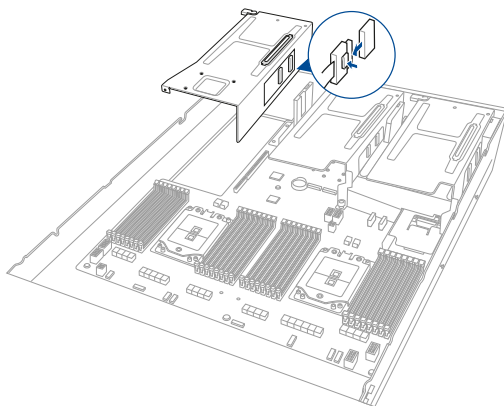

4. Place the riser card bracket on a flat and stable surface in the orientation as shown.
5. Flip the metal bracket lock open.
6. Install the OCP 3.0 slot baseboard to the **PCIE2** slot on the riser card bracket.
7. Connect the cables.

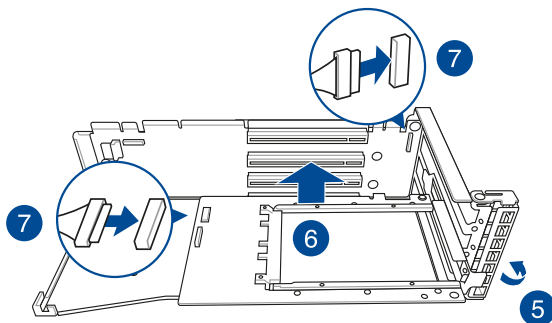

8. Insert the OCP 3.0 card to the OCP 3.0 slot from the rear of the riser card bracket, and make sure the OCP 3.0 card is seated securely in the OCP 3.0 slot.
9. Once your OCP 3.0 card is installed, flip the metal bracket lock back to secure the OCP 3.0 slot baseboard to the riser card bracket.

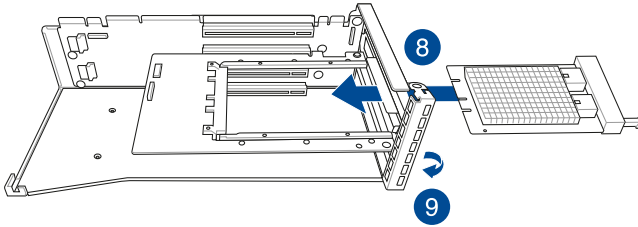

10. Reconnect the cable to the riser card bracket.

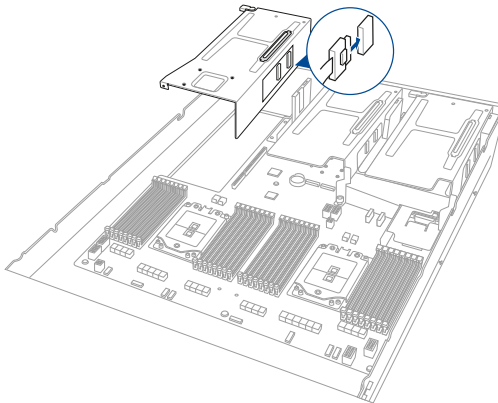

11. Reinstall the riser card to the motherboard.
12. Secure the riser card bracket to the chassis with the thumbscrew.

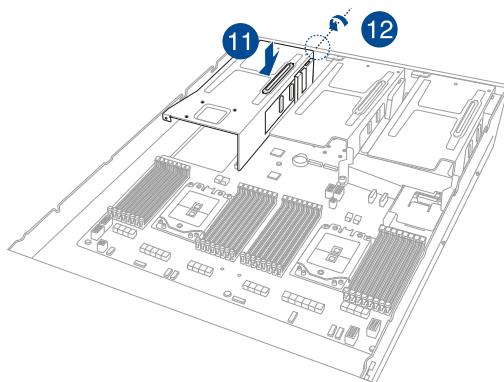

## 2.6.6 Installing an ethernet expansion card to the riser card bracket

The pre-installed riser card bracket can support a 4-port or 2-port ethernet expansion card.



Do not install the 4-port ethernet expansion card if you wish to install the external rear fan.

To install a 4-port or 2-port ethernet expansion card on the riser card bracket:

1. Follow steps 1-2 of **Installing an expansion card to the riser card bracket 4** to remove the riser card bracket from the chassis.
2. Flip the riser card bracket over and insert the 4-port or 2-port ethernet expansion card to the **PCI\_E\_LAN1** slot (A) on the riser card bracket, then secure it using two (2) screws (B).

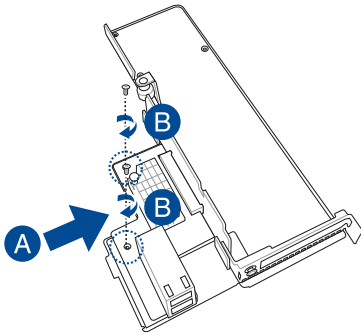

2-port Ethernet expansion card

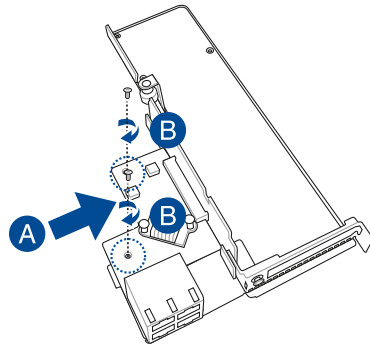

4-port Ethernet expansion card

3. Follow steps 5-6 of **Installing an expansion card to the riser card bracket 4** to install the riser card bracket to the chassis.

## 2.6.7 Installing GPU cards (on selected models)

To install a passive GPU (FH/FL) card to the riser card bracket 1:

1. Loosen the thumbscrew securing the riser card bracket to the chassis.
2. Lift the riser card out of the chassis by firmly holding it by the tab and pulling it upwards to detach it from the PCIe slot on the motherboard.

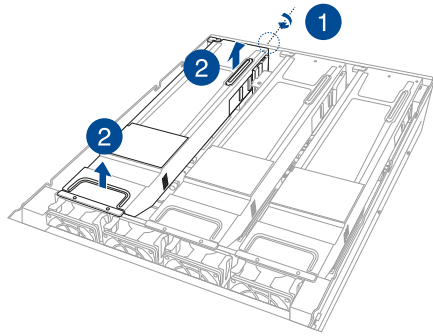

3. Disconnect the cable from the riser card bracket.

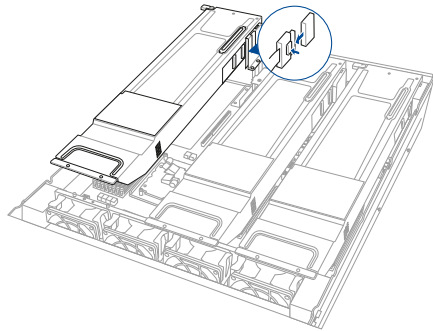

4. Place the riser card bracket on a flat and stable surface in the orientation as shown.
5. Prepare the GPU card.
6. Connect the power cable to the GPU card, and ensure to place the cable through the opening of the GPU air duct.
7. Secure the GPU air duct to the GPU card with the screws.

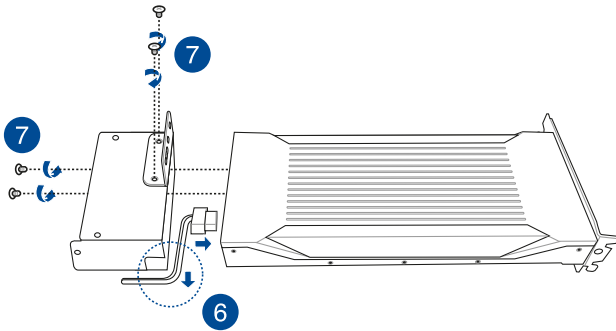

8. Flip the metal bracket lock open.
9. Install the GPU card into the riser card bracket.

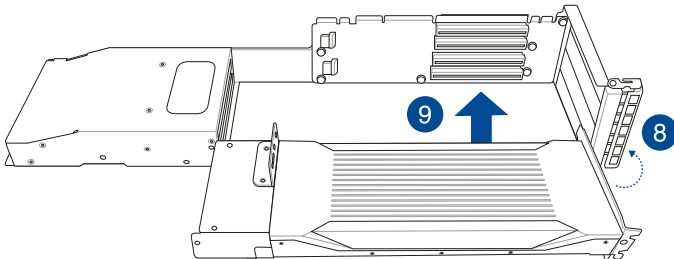

10. Prepare the other GPU card.
11. Install the GPU card into the riser card bracket.

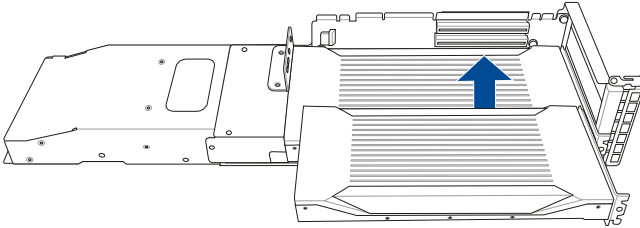

12. Secure the GPU air duct to the GPU card with the screws.
13. Connect the power cable to the GPU card.
14. Flip the metal bracket lock back to secure the GPU cards to the riser card bracket.

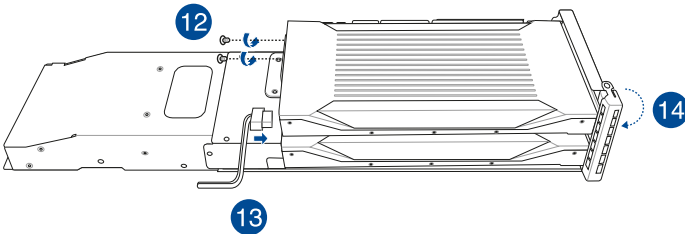

15. Reconnect the cable to the riser card bracket.

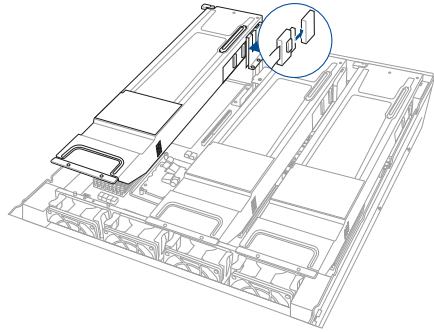

16. Install the riser card bracket and the GPU cards assembly into the PCIe slot on the motherboard. Ensure that the golden connectors of the riser card bracket is firmly seated in place.
17. Secure the riser card bracket to the chassis with the thumbscrew.

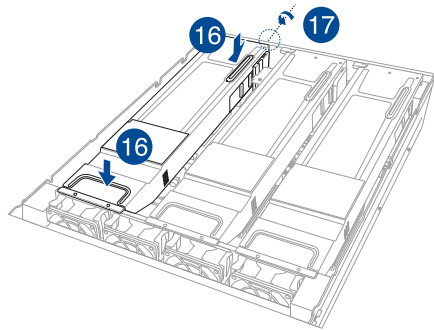

To install a passive GPU (FH/FL) card to the riser card bracket 2:

1. Loosen the thumbscrew securing the riser card bracket to the chassis.
2. Lift the riser card out of the chassis by firmly holding it by the tab and pulling it upwards to detach it from the PCIe slot on the motherboard.

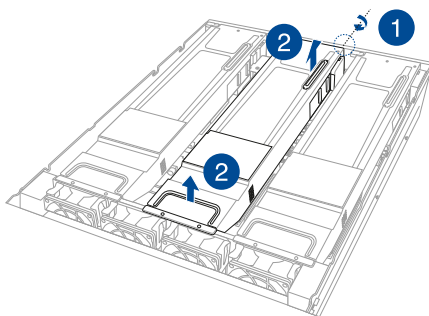

3. Disconnect the cable from the riser card bracket.

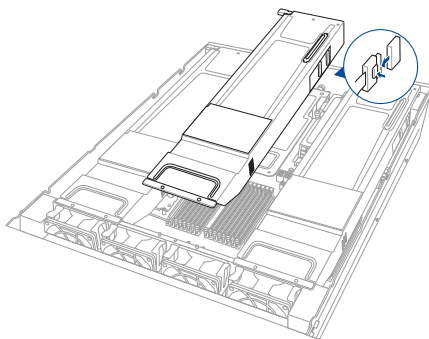

4. Place the riser card bracket on a flat and stable surface in the orientation as shown.
5. Prepare the GPU card.
6. Connect the power cable to the GPU card, and ensure to place the cable through the opening of the GPU air duct
7. Secure the GPU air duct to the GPU card with the screws.

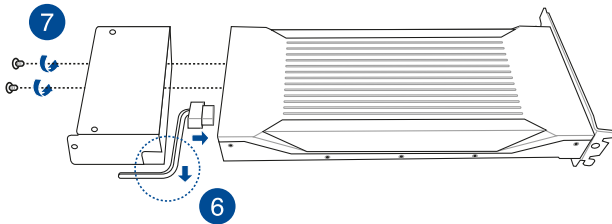

8. Flip the metal bracket lock open.
9. Install the GPU card into the riser card bracket.

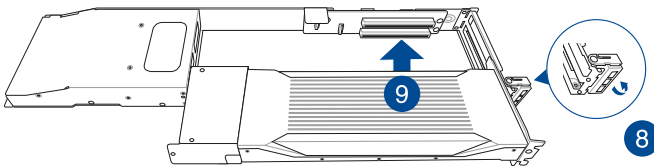

10. Flip the metal bracket lock back to secure the GPU card to the riser card bracket.

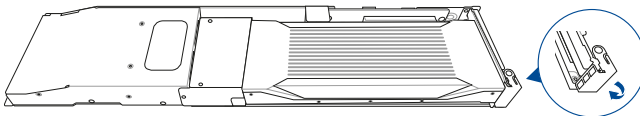

11. Reconnect the cable to the riser card bracket.

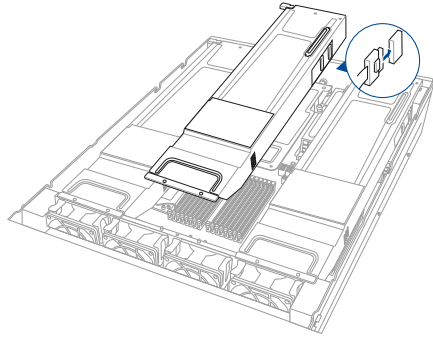

12. Install the riser card bracket and the GPU card assembly into the PCIe slot on the motherboard. Ensure that the golden connectors of the riser card bracket is firmly seated in place.
13. Secure the riser card bracket to the chassis with the thumbscrew.

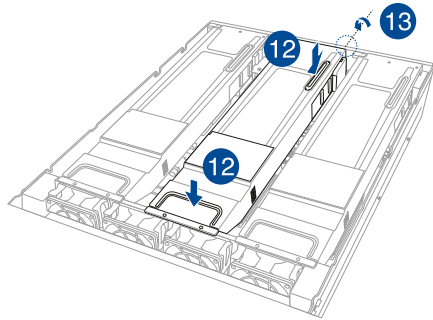

To install a passive GPU (FH/FL) card to the riser card bracket 3:

1. Loosen the thumbscrew securing the riser card bracket to the chassis.
2. Lift the riser card out of the chassis by firmly holding it by the tab and pulling it upwards to detach it from the PCIe slot on the motherboard.

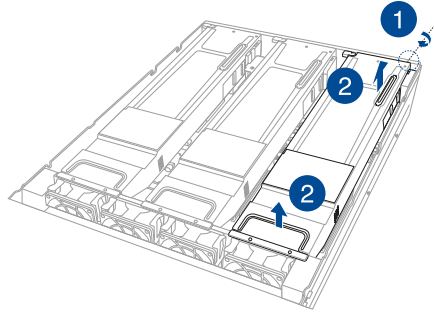

3. Disconnect the cable from the riser card bracket.

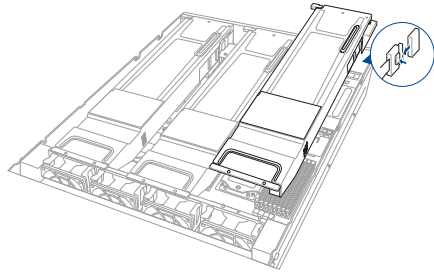

4. Place the riser card bracket on a flat and stable surface in the orientation as shown.
5. Prepare the GPU card.
6. Connect the power cable to the GPU card, and ensure to place the cable through the opening of the GPU air duct
7. Secure the GPU air duct to the GPU card with the screws.

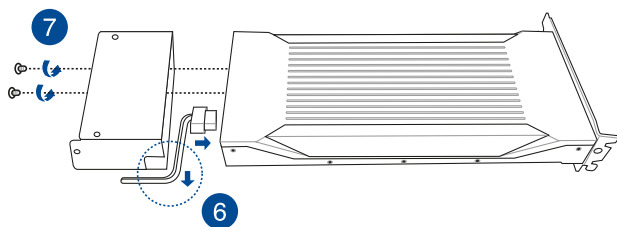

8. Flip the metal bracket lock open.
9. Install the GPU card into the riser card bracket.

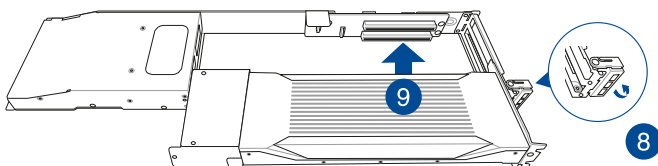

10. Flip the metal bracket lock back to secure the GPU card to the riser card bracket.

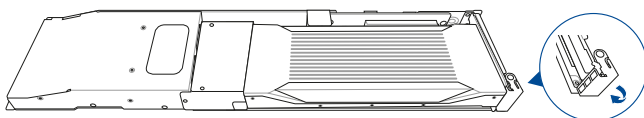

11. Reconnect the cable to the riser card bracket.

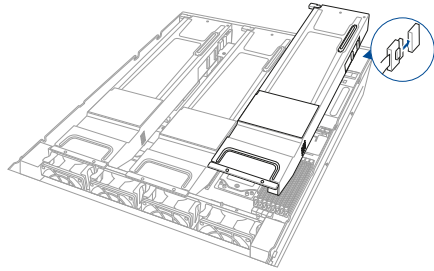

12. Install the riser card bracket and the GPU card assembly into the PCIe slot on the motherboard. Ensure that the golden connectors of the riser card bracket is firmly seated in place.
13. Secure the riser card bracket to the chassis with the thumbscrew.

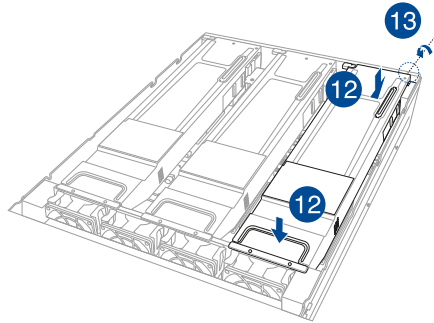

## 2.6.8 Installing an ASUS PIKE II card

You can replace the pre-installed ASUS PIKE II card to support SAS storage devices in your server system.

To remove the pre-installed ASUS PIKE II card:

1. Loosen the thumbscrew securing the riser card bracket to the chassis.
2. Lift the riser card out of the chassis by firmly holding it by the tab and pulling it upwards to detach it from the PCIe slot on the motherboard.

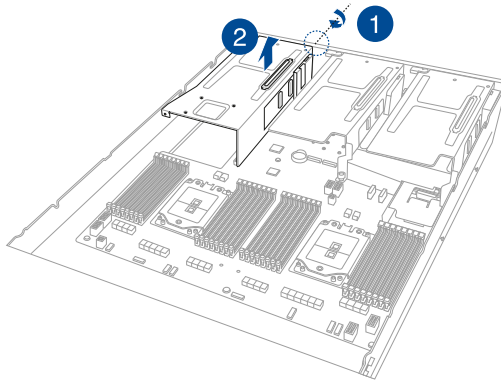

3. Place the riser card bracket on a flat and stable surface in the orientation as shown.
4. Flip the metal bracket lock open.
5. Remove the ASUS PIKE II card from the riser card bracket.

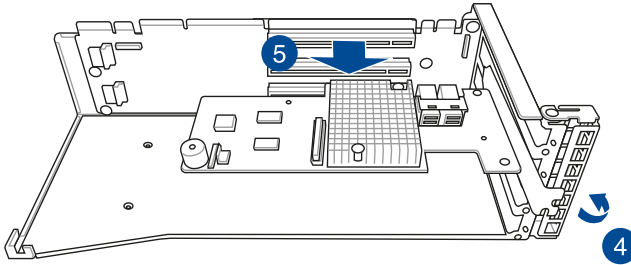

6. Remove the mini SAS HD cables from the ASUS PIKE II card.

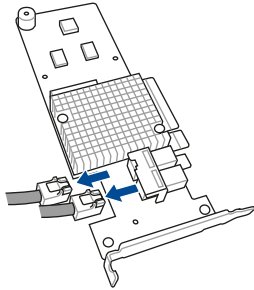

To install an ASUS PIKE II card:

1. Prepare the new ASUS PIKE II card.
2. Insert the ASUS PIKE II card to the PCIe slot on the riser card bracket.
3. Flip the metal bracket lock back to secure the ASUS PIKE II card to the riser card bracket.

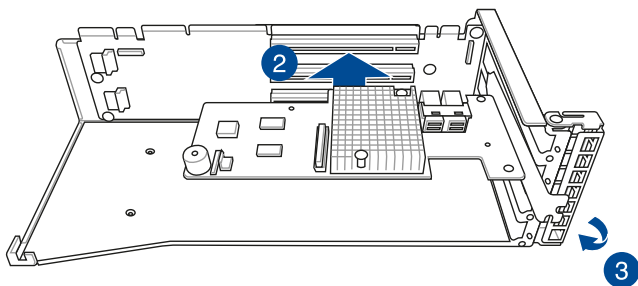

4. Connect the mini SAS HD cables to the ASUS PIKE II card.

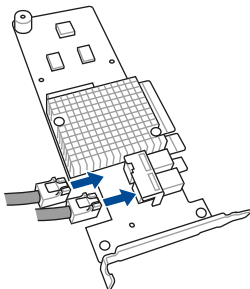

5. Reinstall the riser card to the motherboard.
6. Secure the riser card bracket to the chassis with the thumbscrew.

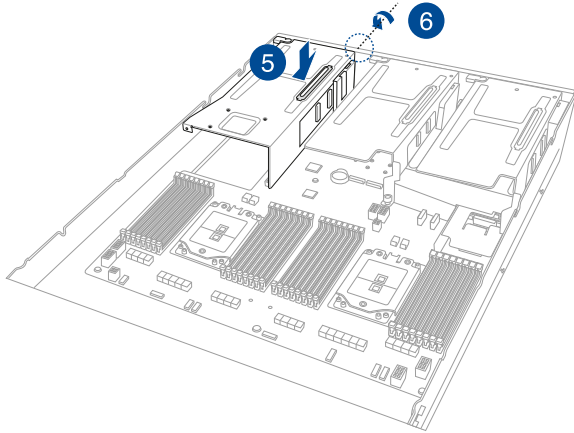

7. Reconnect the cable to the riser card bracket.

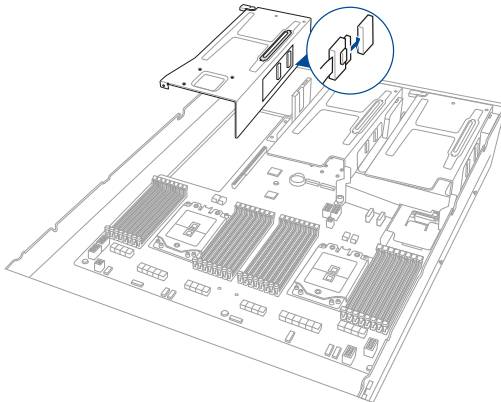

## 2.6.9 Installing M.2 (NGFF) cards

To install an M.2 (NGFF) card:

1. Locate the M.2 connectors (NGFF1 or NGFF2) on the motherboard.

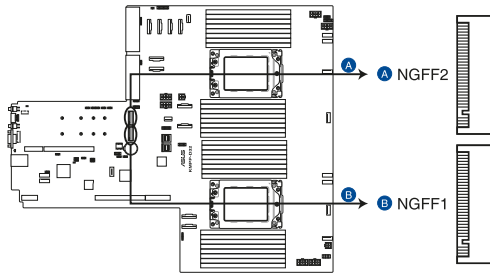

KMPP-D32 NGFF connectors

2. (optional) Remove the stand screw and screw.
3. Select an appropriate screw hole on the motherboard for your M.2 card, then secure the stand to the motherboard.
4. Insert the M.2 into the M.2 (NGFF) slot, then secure it using the screw removed previously.

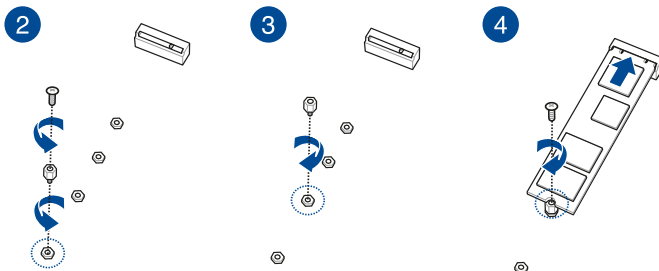

## 2.6.10 Configuring an expansion card

After installing the expansion card, configure it by adjusting the software settings.

1. Turn on the system and change the necessary BIOS settings, if any. See Chapter 5 for information on BIOS setup.
2. Assign an IRQ to the card. Refer to the following tables.
3. Install the software drivers for the expansion card.

### Standard Interrupt assignments

| IRQ | Priority | Standard function           |
|-----|----------|-----------------------------|
| 0   | 1        | System Timer                |
| 1   | 2        | Keyboard Controller         |
| 2   | -        | Programmable Interrupt      |
| 3*  | 11       | Communications Port (COM2)  |
| 4*  | 12       | Communications Port (COM1)  |
| 5*  | 13       | --                          |
| 6   | 14       | Floppy Disk Controller      |
| 7*  | 15       | --                          |
| 8   | 3        | System CMOS/Real Time Clock |
| 9*  | 4        | ACPI Mode when used         |
| 10* | 5        | IRQ Holder for PCI Steering |
| 11* | 6        | IRQ Holder for PCI Steering |
| 12* | 7        | PS/2 Compatible Mouse Port  |
| 13  | 8        | Numeric Data Processor      |
| 14* | 9        | Primary IDE Channel         |
| 15* | 10       | Secondary IDE Channel       |

\* These IRQs are usually available for ISA or PCI devices.

## 2.7 Cable connections



- The bundled system cables are pre-connected before shipment. You do not need to disconnect these cables unless you are going to remove pre-installed components to install additional devices.
- Refer to Chapter 4 for detailed information on the connectors.

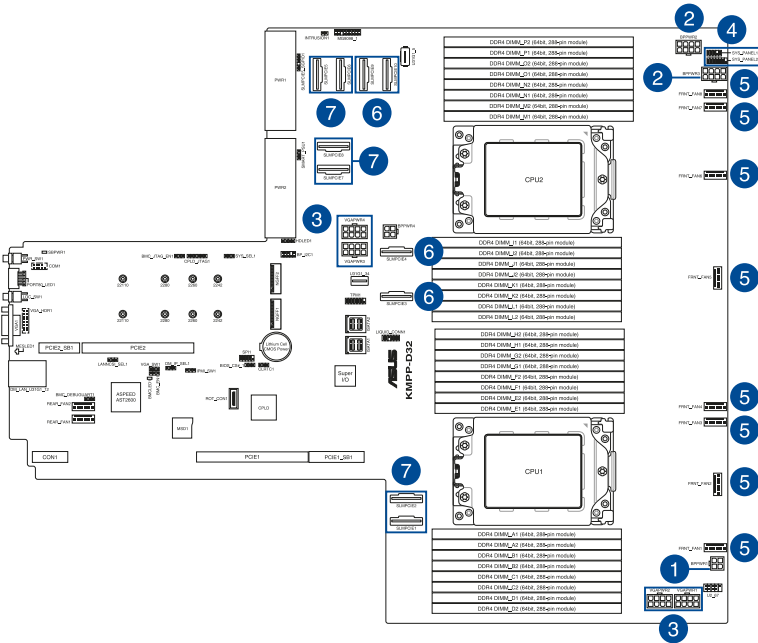

### Pre-connected system cables

1. 4-pin BPPWR1 power connector (connected to backplane)
2. 8-pin BPPWR2 power connector (connected to backplane)
3. 8-pin VGA power connectors (connected to Graphics card, on selected models)
4. Panel connector (connected to front I/O board)
5. System fan connectors (from motherboard FAN1-8 to system fans)
6. SLMPCIE3, SLMPCIE4, SLMPCIE9, SLMPCIE10 Slim PCIe connectors (connected to backplane)
7. SLMPCIE1, SLMPCIE2, SLMPCIE5, SLMPCIE6, SLMPCIE7, SLMPCIE8 Slim PCIe connectors (connected to PCIe riser card)

## 2.8 SATA/SAS backplane cabling

### 24 NVMe non-GPU model

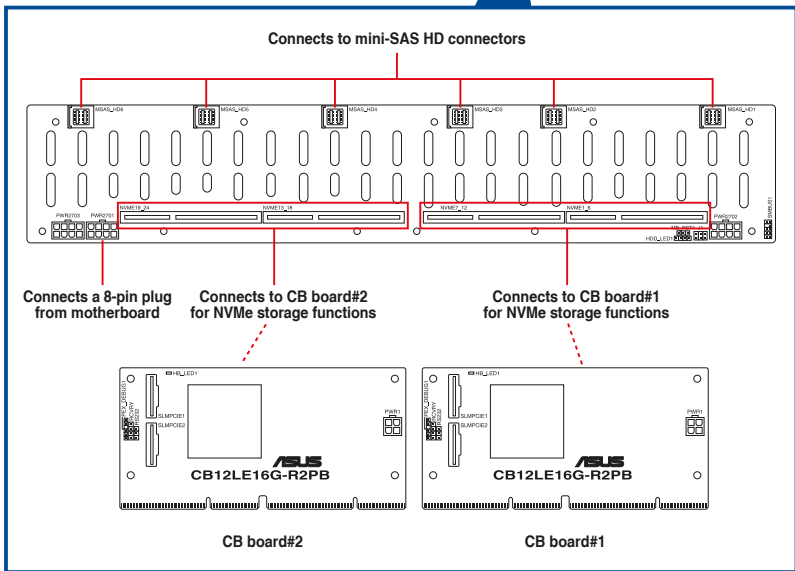
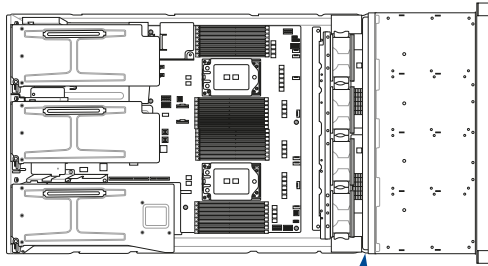

| Backplane connector   | Cable                          | Connect to               |
|-----------------------|--------------------------------|--------------------------|
| SLMPcie1 (CB Board#1) | Slimline PCIe to Slimline PCIe | SLMPcie3 on motherboard  |
| SLMPcie2 (CB Board#1) | Slimline PCIe to Slimline PCIe | SLMPcie4 on motherboard  |
| SLMPcie1 (CB Board#2) | Slimline PCIe to Slimline PCIe | SLMPcie9 on motherboard  |
| SLMPcie2 (CB Board#2) | Slimline PCIe to Slimline PCIe | SLMPcie10 on motherboard |

## 12 NVMe GPU model

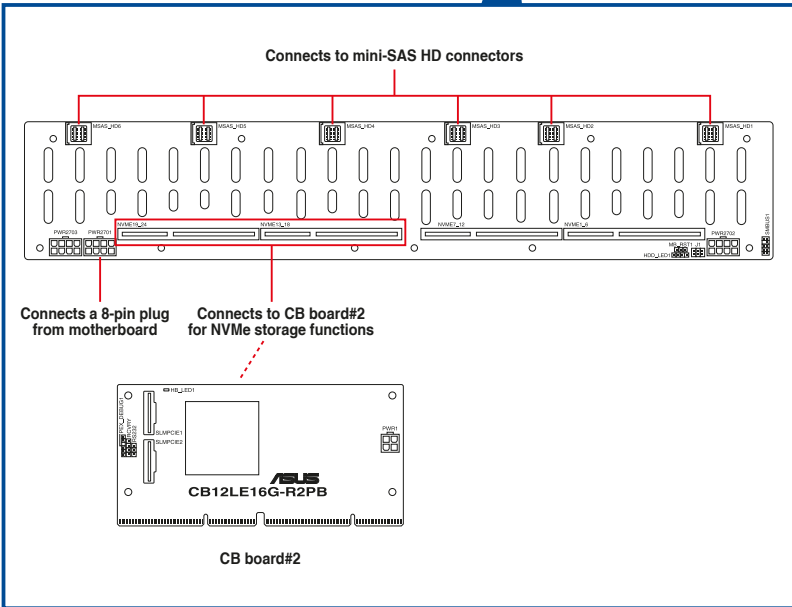
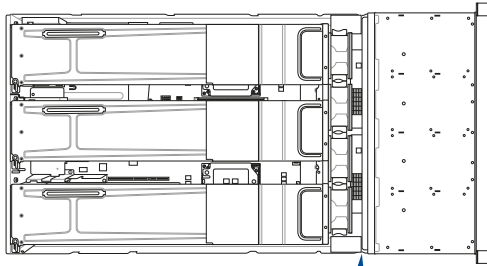

| Backplane connector   | Cable                          | Connect to               |
|-----------------------|--------------------------------|--------------------------|
| SLMPCIE1 (CB Board#2) | Slimline PCIe to Slimline PCIe | SLMPCIE9 on motherboard  |
| SLMPCIE2 (CB Board#2) | Slimline PCIe to Slimline PCIe | SLMPCIE10 on motherboard |

## 2.9 Removable/optional components

This section explains how to install optional components into the system and covers the following components:

1. System fans
2. Redundant power supply module



---

Ensure that the system is turned off before removing any components.

---



---

You may need to remove previously installed component or factory shipped components when installing optional components.

---

### 2.9.1 System fans

To remove the system fans:

1. Locate the fan you want to replace.
2. Press the retaining clip (A) and lift upward (B) to remove the fan.

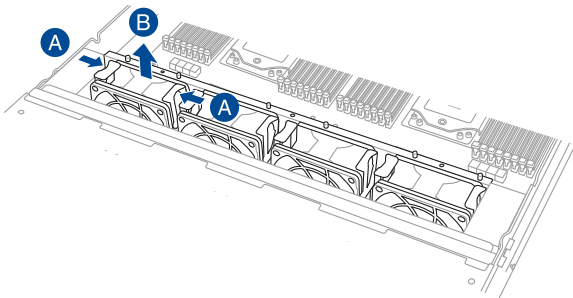

To reinstall the system fans:

1. Prepare the fan with the same model and size.
2. Install the fan to the fan cage.

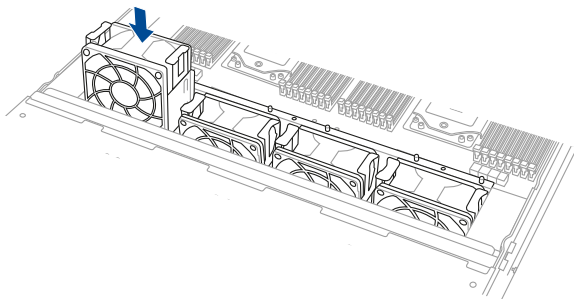

---

The fan can only be installed in one direction. If the fan cannot be installed, turn it around and try again.

---

To install the external rear fan:

1. Use a screwdriver to pry open the slot.



---

Do not install the 4-port ethernet expansion card if you wish to install the external rear fan.

---

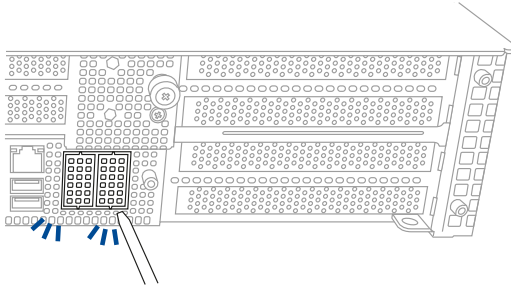

2. Prepare the rear external fan.
3. Connect the cable of the rear external fan to the motherboard through the open slot.

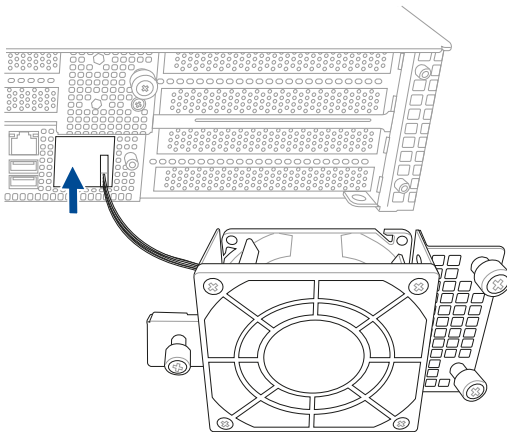

4. Align and place the rear external fan on the chassis.
5. Secure the rear external fan to the chassis with the thumbscrews.

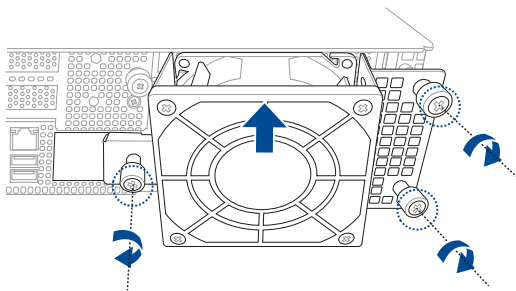

## 2.9.2 Redundant power supply module

To replace a failed redundant power supply module:

1. Lift up the power supply module lever.

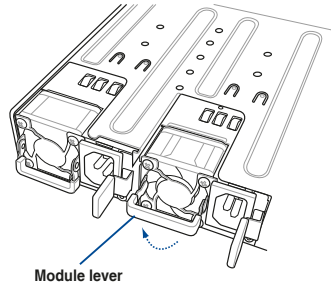

2. Hold the power supply module lever and press the PSU latch, then pull the power supply module out of the system chassis.

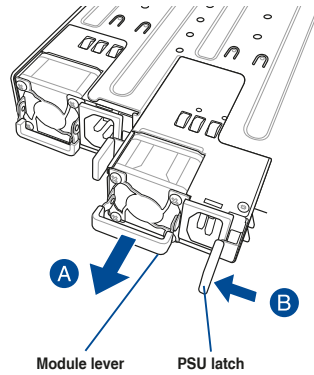

3. Prepare the replacement power supply module.
4. Insert the replacement power supply module into the chassis then push it inwards until the latch locks into place.

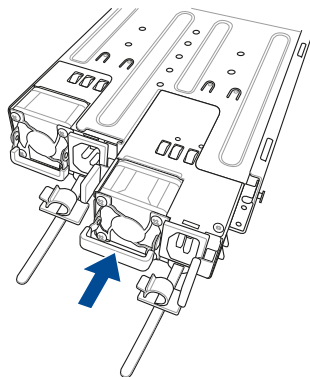



# Installation Options

# 3

This chapter describes how to install the optional components and devices into the barebone server.

### 3.1 Tool-less Friction Rail Kit

The tool less design of the rail kit allows you to easily install the rack rails into the server rack without the need for additional tools. The kit also comes with a metal stopping bracket that can be installed to provide additional support and stability to the server.

The tool-less rail kit package includes:

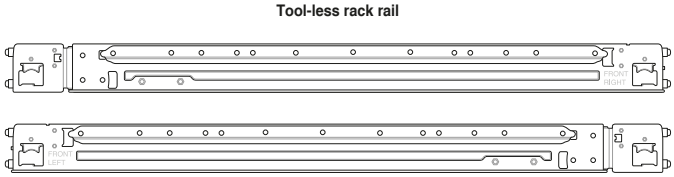
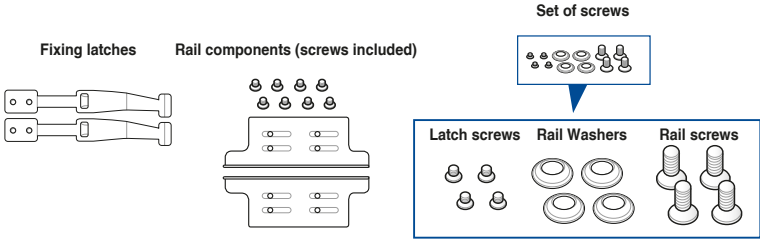

## 3.2 Installing the tool-less rack rail

To install the tool-less rack rails into the rack:

1. Secure the two fixing latches to the two sides of the server using the set of latch screws.



The locations of the screw holes vary with different server models. Refer to your server user manual for details.

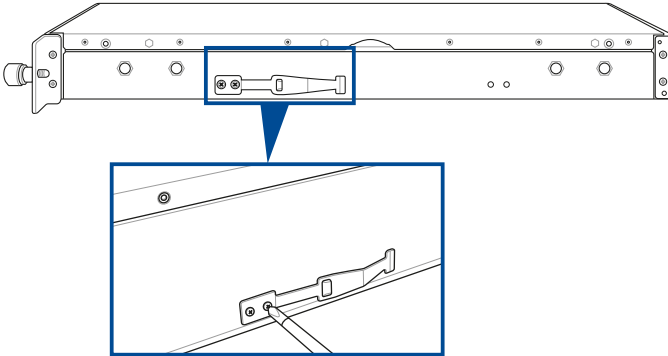

2. Select a desired space and place the appropriate rack rail (left and right) on opposite positions on the rack.



A 1U space consists of three square mounting holes with two thin lips on the top and the bottom.

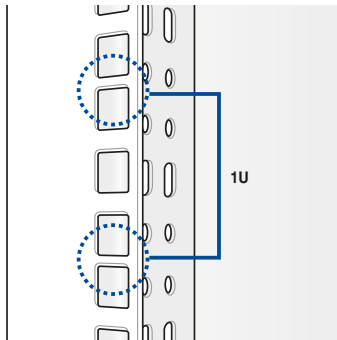

3. Secure the rail components to the rail using the bundled screws.
4. Press the spring lock (A) then insert the studs into the selected square mounting holes on the rack post.
5. Press the spring lock on the other end of rail then insert the stud into the mounting hole on the rack post. Extend the rack rail, if necessary.
6. (Optional) Use the rail screw and rail washer (B) that comes with the kit to secure the rack rail to the rack post.
7. Perform steps 3 to 5 for the other rack rail.



---

Ensure that the installed rack rails (left and right) are aligned, secured, and stable in place.

---

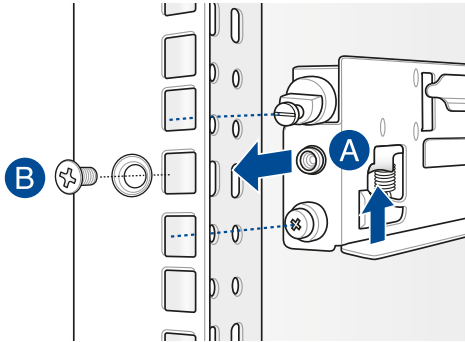

8. Lift the server chassis and insert it into the rack rail.



---

Ensure that the rack rail cabinet and the rack posts are stable and standing firmly on a level surface.

---

### 3.3 Rail kit dimensions

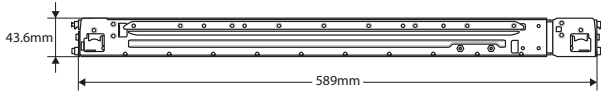
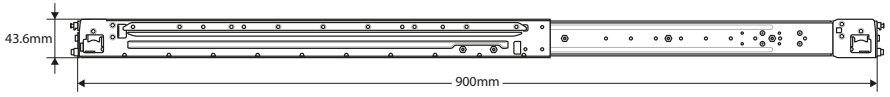

### 3.4 Cable management arm (optional for 1200 mm rack rails)

You can install an additional cable management arm (CMA) to the rack rails to help you manage the cables from your server system. The CMA is designed with movable parts that allow you to move the server along the rack rail without the need to remove the CMA.

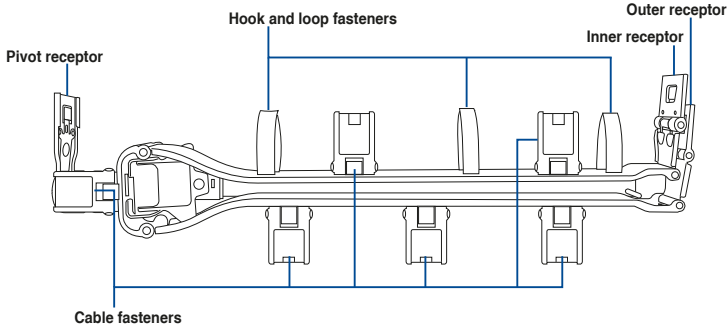

#### 3.4.1 Attaching the cable management arm

##### Installing the cable management arm

To install the cable management arm:

1. Install the rack rails into the rack.



Refer to section 3.1 **Tool-less Friction Rail Kit** for the steps on installing the rack rails into the rack.

2. Press the round button on the pivot receptor, then rotate the pivot receptor to the left or right for a left pivot configuration or right pivot configuration.

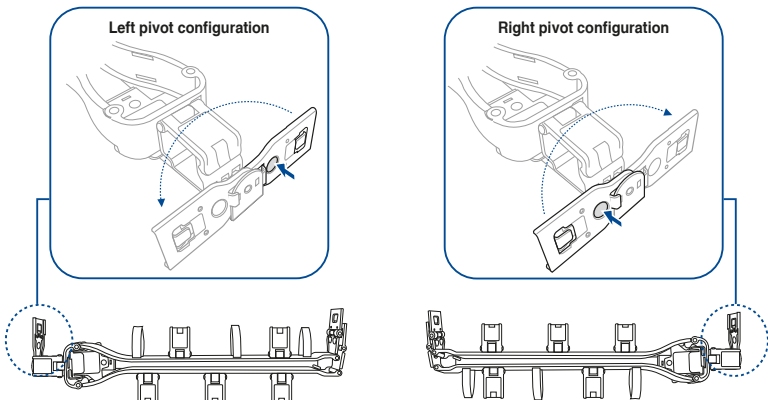

3. Align the three receptors on the CMA with the connectors on the rack rails.

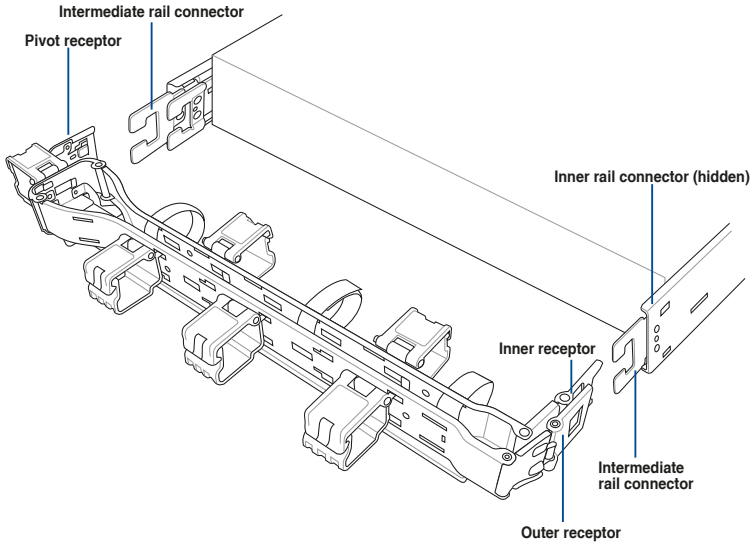

The installation steps in this section uses a **Left pivot configuration** as an example, the installation steps for a **Right pivot configuration** is similar.

4. Align and connect the inner receptor on the CMA with the connector on the inner rail.

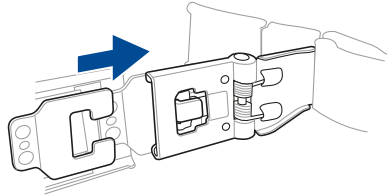

5. Align and connect the outer receptor on the CMA with the connector on the intermediate rail.

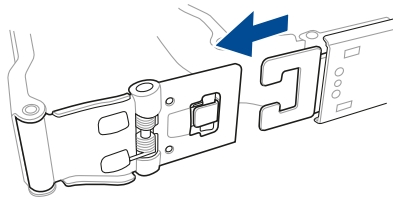

- 6. Align and connect the pivot receptor on the CMA with the connector on the other intermediate rail.

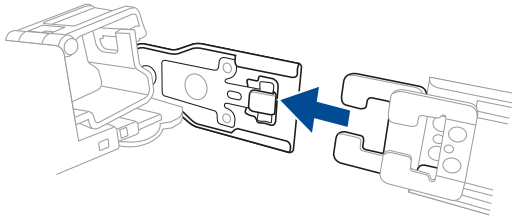

- 7. Pass the cables from the server system through the hook and loop fasteners and the cable fasteners on the CMA to complete.

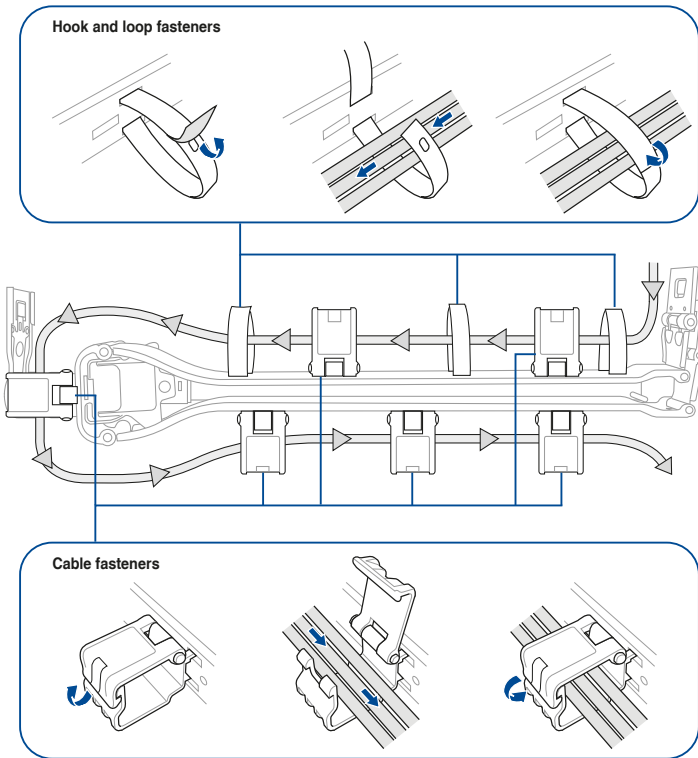

# Motherboard Information

# 4

This chapter includes the motherboard layout and brief descriptions of the jumpers and internal connectors.

# 4.1 Motherboard layout

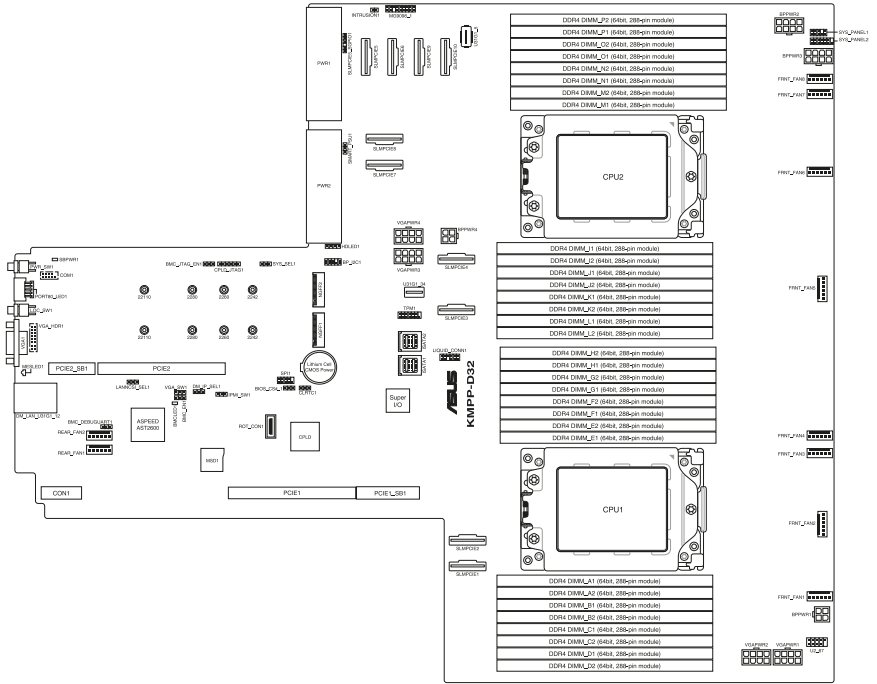

## Layout contents

| Jumpers  | Page |
|--|------|
| 1. Clear RTC RAM (3-pin CLRTC1)                            | 4-4  |
| 2. VGA controller setting (3-pin VGA_SW1)                  | 4-5  |
| 3. LANNCSI setting (3-pin LANNCSI_SEL1)                    | 4-5  |
| 4. Baseboard Management Controller setting (3-pin BMC_EN1) | 4-6  |
| 5. DMLAN setting (3-pin DM_IP_SEL1)                        | 4-6  |
| 6. IPMI SW setting (3-pin IPMI_SW1)                        | 4-7  |
| 7. Smart Ride Through (SmaRT) setting (3-pin SMART_PSU1)   | 4-7  |
| 8. System select setting (3-pin SYS_SEL1)                  | 4-8  |

| Onboard LEDs                                     | Page |
|--|------|
| 1. Standby Power LED (SBPWR1)                    | 4-9  |
| 2. Baseboard Management Controller LED (BMCLED1) | 4-9  |
| 3. Message LED (MESLED1)                         | 4-10 |

| Internal connectors   | Page |
|---|------|
| 1. Mini-SAS HD connector (ISATA1-2)                                   | 4-11 |
| 2. Slim PCIe connector (SLIMPCIE1-10)                                 | 4-11 |
| 3. USB 2.0 connector (10-1 pin U2_67)                                 | 4-12 |
| 4. USB 3.2 Gen 1 connector (U31G1_34; U31G1_5)                        | 4-12 |
| 5. Chassis Intrusion (2-pin INTRUSION1)                               | 4-13 |
| 6. Serial port connector (10-1 pin COM1)                              | 4-13 |
| 7. System fan connectors (6-pin FRNT_FAN1-8; 6-pin REAR_FAN1-2)       | 4-14 |
| 8. TPM connector (14-1 pin TPM1)                                      | 4-15 |
| 9. M.2 (NGFF) card connector (NGFF1-2)                                | 4-15 |
| 10. Back panel power connector (4-pin BPPWR1, BPPWR4; 8-pin BPPWR2-3) | 4-16 |
| 11. VGA power connector (8-pin VGAPWR1-4)                             | 4-16 |
| 12. VGA connector (16-pin VGA_HDR1)                                   | 4-17 |
| 13. Micro SD card slot (MSD1)   | 4-17 |
| 14. System panel connector (10-1 pin PANEL1; 14-1 pin PANEL2)         | 4-18 |
| 15. Storage device activity LED connector (4-pin HDLED1)              | 4-19 |
| 16. I <sup>2</sup> C connector (10-1 pin BP_I2C1)                     | 4-20 |
| 17. BMC Debug UART connector (3-pin BMC_DEBUGUART1)                   | 4-20 |
| 18. CPLD JTAG1 connector (6-pin CPLD_JTAG1)                           | 4-21 |
| 19. Liquid connector (12-1 pin LIQUID_CONN1)                          | 4-21 |
| 20. SLMPCIE SGPIO connector (6-1 pin SLMPCIE5_SGPIO1)                 | 4-22 |

## 4.2 Jumpers

### 1. Clear RTC RAM (3-pin CLRTC1)

This jumper allows you to clear the Real Time Clock (RTC) RAM in CMOS. You can clear the CMOS memory of date, time, and system setup parameters by erasing the CMOS RTC RAM data. The onboard button cell battery powers the RAM data in CMOS, which include system setup information such as system passwords.

To erase the RTC RAM:

1. Turn OFF the computer and unplug the power cord.
2. Move the jumper cap from pins 1–2 (default) to pins 2–3. Keep the cap on pins 2–3 for about 5–10 seconds, then move the cap back to pins 1–2.
3. Plug the power cord and turn ON the computer.
4. Hold down the <Del> key during the boot process and enter BIOS setup to re-enter data.



Except when clearing the RTC RAM, never remove the cap on CLRTC jumper default position. Removing the cap will cause system boot failure!



If the steps above do not help, remove the onboard battery and move the jumper again to clear the CMOS RTC RAM data. After the CMOS clearance, reinstall the battery.

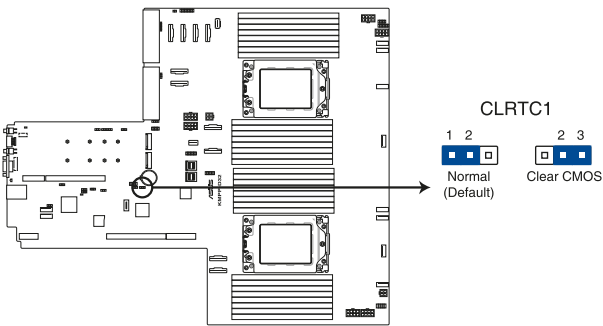

**KMPP-D32 Clear RTC RAM**

## 2. VGA controller setting (3-pin VGA\_SW1)

This jumper allows you to enable or disable the onboard VGA controller. Set to pins 1–2 to activate the VGA feature.

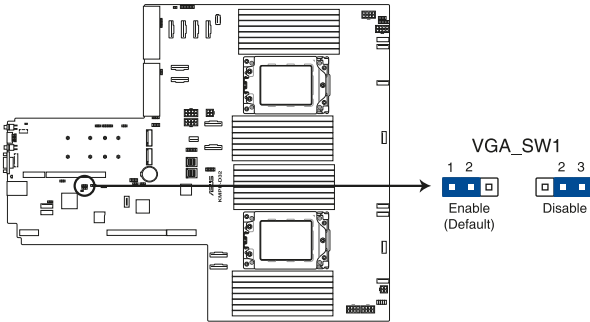

**KMPP-D32 VGA setting**

## 3. LANNCSEI setting (3-pin LANNCSEI\_SEL1)

This jumper allows you to select which LAN NCSI function to use.

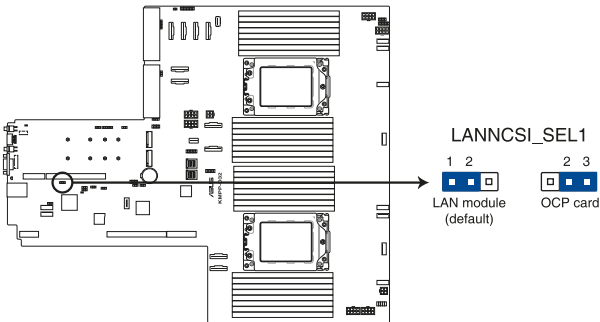

**KMPP-D32 LANNCSEI setting**

**4. Baseboard Management Controller setting (3-pin BMC\_EN1)**

This jumper allows you to enable (default) or disable on-board BMC. Ensure to set this BMC jumper to enabled to avoid system fan control and hardware monitor error.

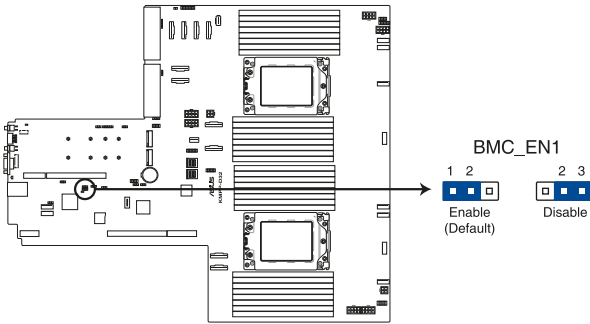

**KMPP-D32 BMC setting**

**5. DMLAN setting (3-pin DM\_IP\_SEL1)**

This jumper allows you to select the DMLAN setting. Set to pins 2-3 to force the DMLAN IP to static mode (IP=10.10.10.10, submask=255.255.255.0).

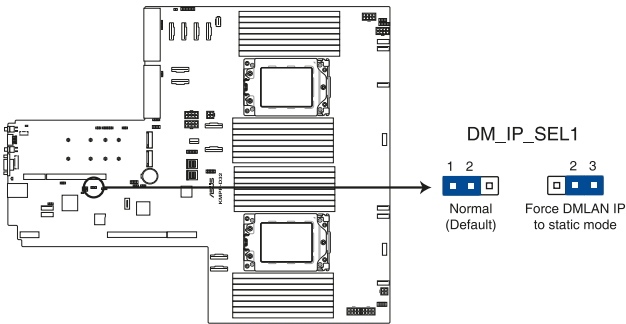

**KMPP-D32 DM\_IP\_SEL1 setting**

## 6. IPMI SW setting (3-pin IPMI\_SW1)

This jumper allows you to select which protocol in the GPU sensor to function.

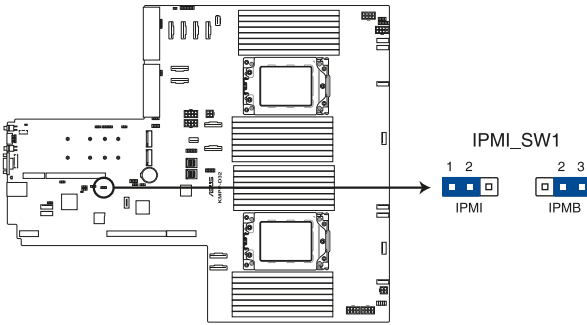

**KMPP-D32 IPMI\_SW1 setting**

## 7. Smart Ride Through (SmaRT) setting (3-pin SMART\_PSU1)

This jumper allows you to enable or disable the Smart Ride Through (SmaRT) function. This feature is enabled by default. Set to pins 2-3 to disable it. When enabled, SmaRT allows uninterrupted operation of the system during an AC loss event.

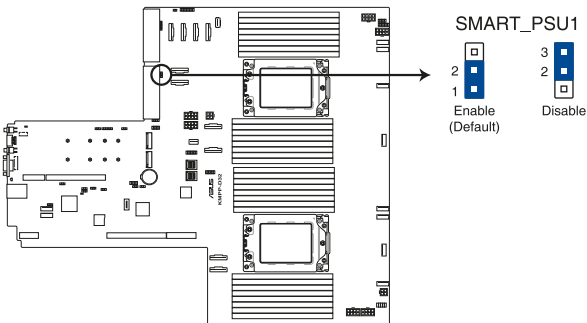

**KMPP-D32 Smart Ride Through setting**

**8. System select setting (3-pin SYS\_SEL1)**

This jumper is for toggling between RS700A-E11 or RS720A-E11 configurations.

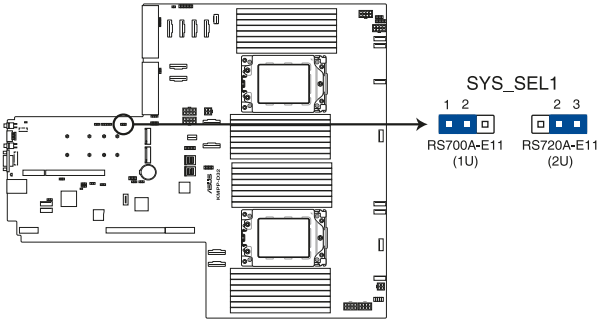

**KMPP-D32 SYS\_SEL1 setting**

## 4.3 Internal LEDs

### 1. Standby Power LED (SBPWR1)

The motherboard comes with a standby power LED. The green LED lights up to indicate that the system is ON, in sleep mode, or in soft-off mode. This is a reminder that you should shut down the system and unplug the power cable before removing or plugging in any motherboard component. The illustration below shows the location of the onboard LED.

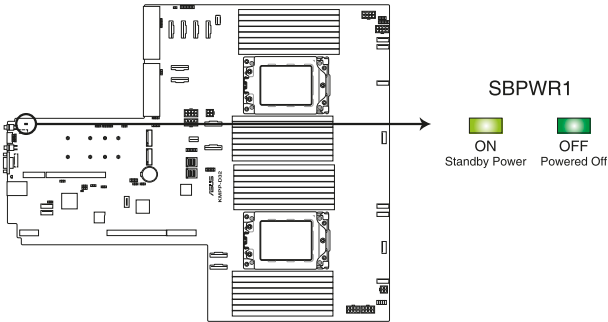

**KMPP-D32 Standby Power LED**

### 2. Baseboard Management Controller LED (BMCLED1)

The BMC LED lights up to indicate that the on-board BMC is functional.

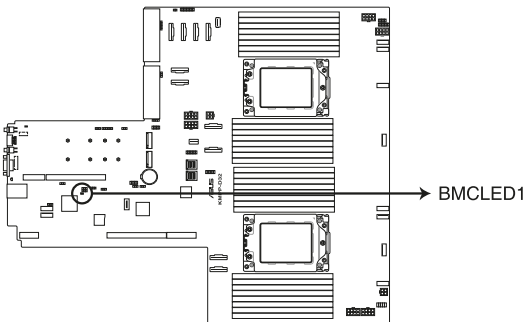

**KMPP-D32 BMC LED**

**3. Message LED (MESLED1)**

This onboard LED lights up to red when there is a BMC event log is generated.

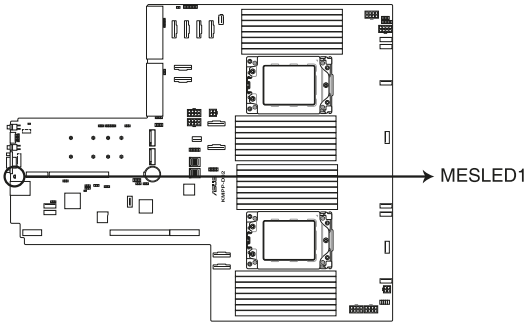

**KMPP-D32 MESLED**

## 4.4 Internal connectors

### 1. Mini-SAS HD connector (ISATA1-2)

This motherboard comes with mini Serial Attached SCSI (SAS) HD connectors, the storage technology that supports Serial ATA. Each connector supports up to four devices.

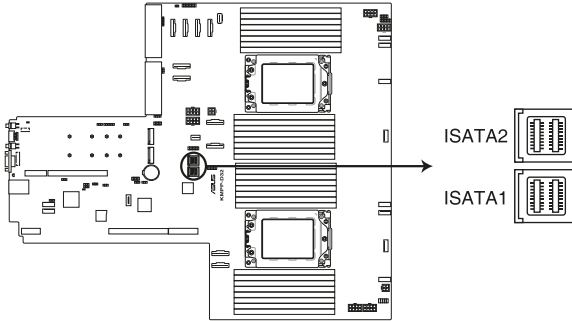

**KMPP-D32 ISATA connectors**

### 2. Slim PCIe connector (SLMPCIE1-10)

Connects the PCIe signal to the front riser card or NVMe port on the backplane.

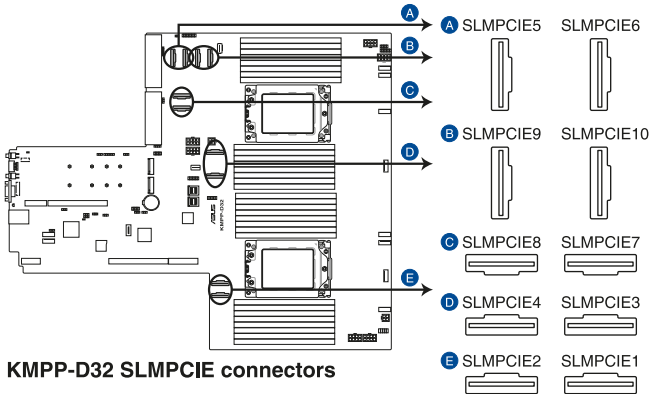

**KMPP-D32 SLMPCIE connectors**

**3. USB 2.0 connector (10-1 pin U2\_67)**

This connector is for USB 2.0 ports. Connect the USB module cable to the connector, and then install the module to a slot opening at the back of the system chassis. The USB connectors comply with USB 2.0 specification that supports up to 480 Mbps connection speed.

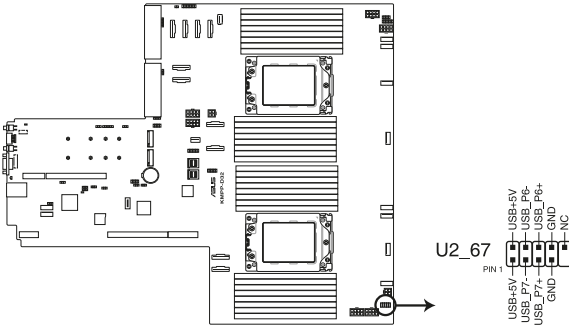

**KMPP-D32 USB 2.0 connector**



The USB port module is purchased separately.

**4. USB 3.2 Gen 1 connector (U31G1\_34; U31G1\_5)**

This connector allows you to connect a USB 3.2 Gen 1 module for additional USB 3.2 Gen 1 ports on the front panel. The USB 3.2 Gen 1 connector provides data transfer speeds of up to 10 Gb/s. The Type-A connector allows you to directly connect a USB flash drive.

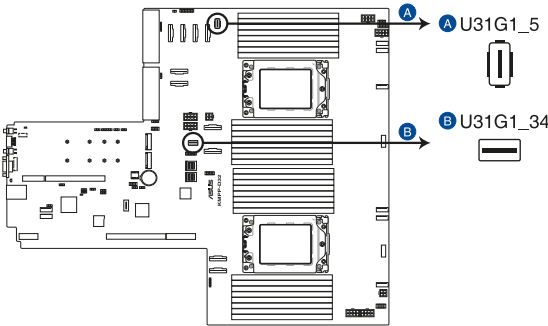

**KMPP-D32 USB 3.2 Gen 1 connector**

## 5. Chassis Intrusion (2-pin INTRUSION1)

These leads are for the intrusion detection feature for chassis with intrusion sensor or microswitch. When you remove any chassis component, the sensor triggers and sends a high level signal to these leads to record a chassis intrusion event. The default setting is to short the CHASSIS# and the GND pin by a jumper cap to disable the function.

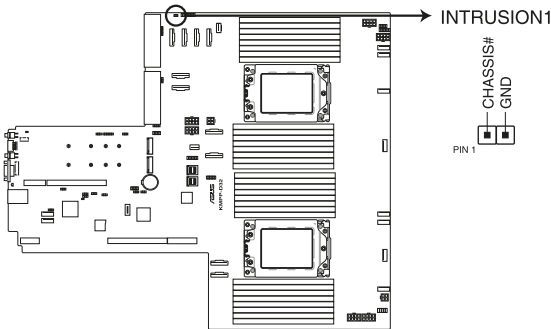

**KMPP-D32 Chassis Intrusion connector**

## 6. Serial port connector (10-1 pin COM1)

This connector is for a serial (COM) port. Connect the serial port module cable to this connector, then install the module to a slot opening at the back of the system chassis.

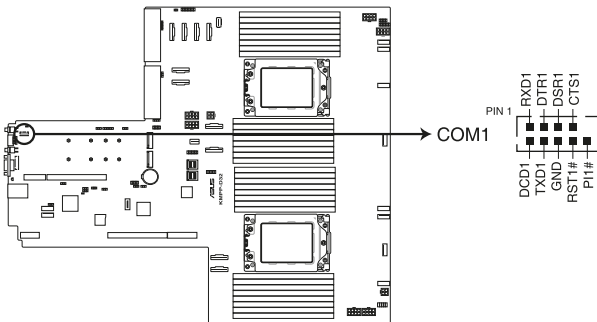

**KMPP-D32 Serial port connector**



The COM module is purchased separately.

## 7. System fan connectors (6-pin FRNT\_FAN1-8; 6-pin REAR\_FAN1-2)

The fan connectors support cooling fans of 0.8A–1.0A (12 W max.) or a total of 6.4 A–8.0 A (96 W max.) at +12V. Connect the fan cables to the fan connectors on the motherboard, making sure that the black wire of each cable matches the ground pin of the connector.



DO NOT forget to connect the fan cables to the fan connectors. Insufficient air flow inside the system may damage the motherboard components. These are not jumpers! DO NOT place jumper caps on the fan connectors!

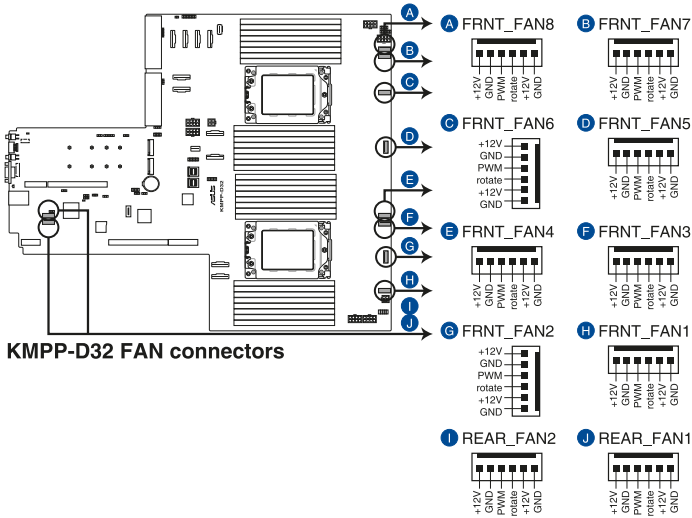

## 8. TPM connector (14-1 pin TPM1)

This connector supports a Trusted Platform Module (TPM) system, which can securely store keys, digital certificates, passwords, and data. A TPM system also helps enhance network security, protects digital identities, and ensures platform integrity.

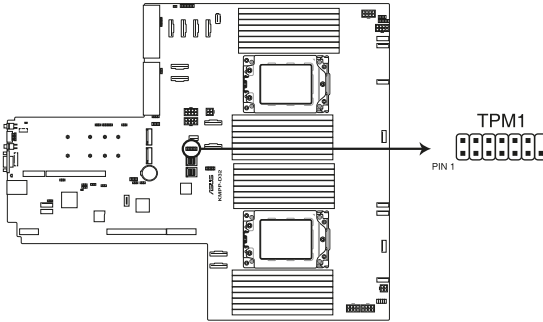

**KMPD-D32 TPM connector**

## 9. M.2 (NGFF) card connector (NGFF1-2)

These connectors allow you to install M.2 devices.

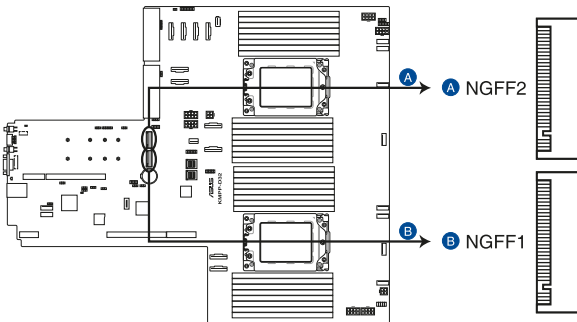

**KMPD-D32 NGFF connectors**



This connector supports type 2242 / 2260 / 2280 / 22110 devices on both PCI-E and SATA interface.



The M.2 (NGFF) device is purchased separately.

### 10. Back panel power connector (4-pin BPPWR1, BPPWR4; 8-pin BPPWR2-3)

These connectors are for the power supply plugs that connects to the back panel. The power supply plugs are designed to fit these connectors in only one orientation. Find the proper orientation and push down firmly until the connectors completely fit.

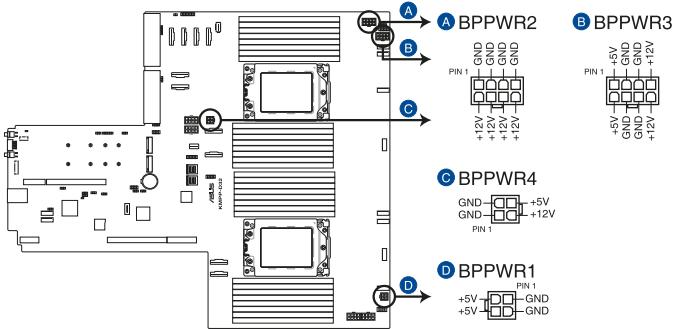

**KMPP-D32 BP power connectors**



DO NOT connect VGA cards to these connectors. Doing so may cause system boot errors and permanent damage to your motherboard or device.

### 11. VGA power connectors (8-pin VGAPWR1-4)

These connectors are for the power supply plugs that connects to the VGA card. The power supply plugs are designed to fit these connectors in only one orientation. Find the proper orientation and push down firmly until the connectors completely fit.

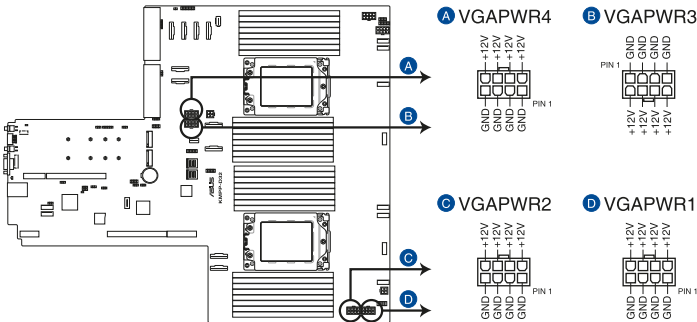

**KMPP-D32 VGA power connectors**



DO NOT connect the back panel to these connectors. Doing so may cause system boot errors and permanent damage to your motherboard or device.

## 12. VGA connector (16-pin VGA\_HDR1)

This connector supports the VGA High Dynamic-Range interface.

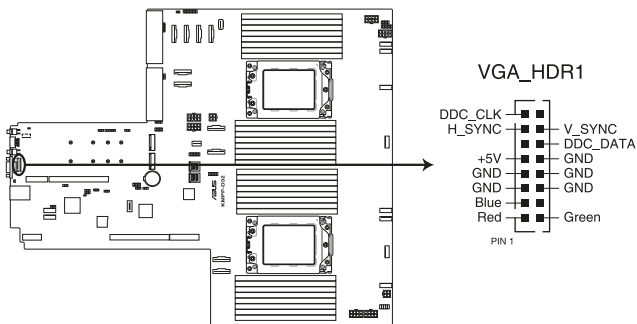

**KMPP-D32 Internal VGA connector**

## 13. Micro SD card slot (MSD1)

Your motherboard supports SD Memory Card v2.00 (SDHC) / v3.00 (SDXC).

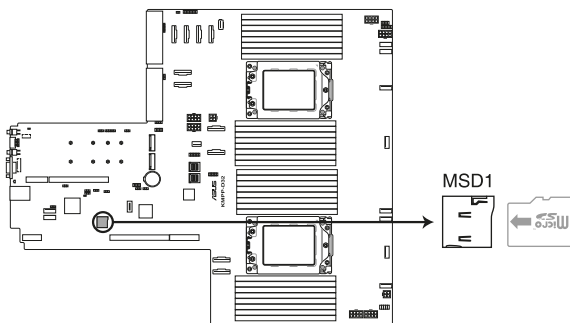

**KMPP-D32 MSD1**



Disconnect all power (including redundant PSUs) from the existing system before you add or remove a Memory Card, then reboot the system to access the Memory Card.



Some memory cards may not be compatible with your motherboard. Ensure that you use only compatible memory cards to prevent loss of data, damage to your device, or memory card, or both.

#### 14. System panel connector (10-1 pin PANEL1; 14-1 pin PANEL2)

This connector supports several chassis-mounted functions.

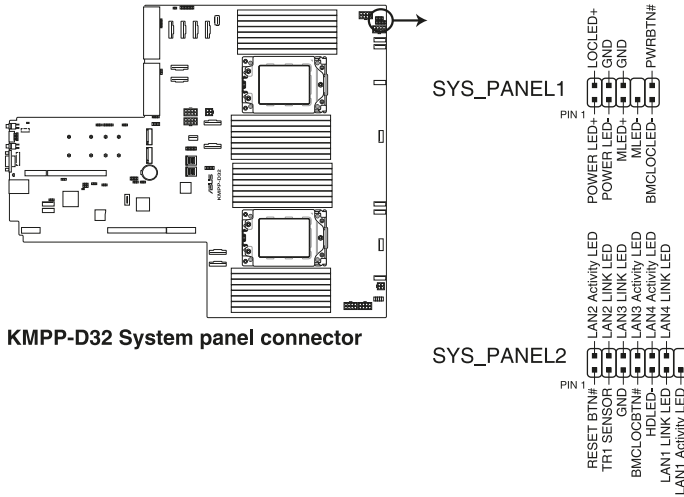

**KMPP-D32 System panel connector**

- System power LED (POWERLED)**

This 2-pin connector is for the system power LED. Connect the chassis power LED cable to this connector. The system power LED lights up when you turn on the system power, and blinks when the system is in sleep mode.
- Message LED (2-pin MLED)**

This 2-pin connector is for the message LED cable that connects to the front message LED. The message LED is controlled by the BMC to indicate an abnormal event occurrence.
- Locator LED connector (BMCLOCLED, LOCLED)**

This connector allows you to connect the Locator LED. The Location LED helps visually locate and identify the server in error on a server rack.
- Power Button/Soft-off Button connector (PWRBTN)**

The 3-1 pin connector allows you to connect the system power button. Press the power button to power up the system, or put the system into sleep or soft-off mode (depending on the operating system settings).
- LAN activity LED connector (LAN1\_LED, LAN2\_LED, LAN3\_LED, LAN4\_LED)**

This 2-pin connector allows you to connect the Gigabit LAN Activity LED.
- Reset button connector (RESET)**

This connector allows you to connect the chassis-mounted reset button. Press the reset button to reboot the system.
- TR1 Sensor connector (TR1 SENSOR)**

This connector allows detection of the environmental temperature of the front panel.

- **Locator button connector (BMCLOCBTN#)**

This connector allows you to connect the Locator button. Press the button to light up the Locator LED.

- **Storage Device Activity LED connector (HDLED)**

This connector allows you to connect the Storage Device Activity LED. The Storage Device Activity LED lights up or blinks when data is read from or written to the storage device or storage device add-on card.

**15. Storage device activity LED connector (4-pin HDLED1)**

This LED connector is for the storage add-on card cable connected to the SATA or SAS add-on card. The read or write activities of any device connected to the SATA or SAS add-on card causes the front panel LED to light up.

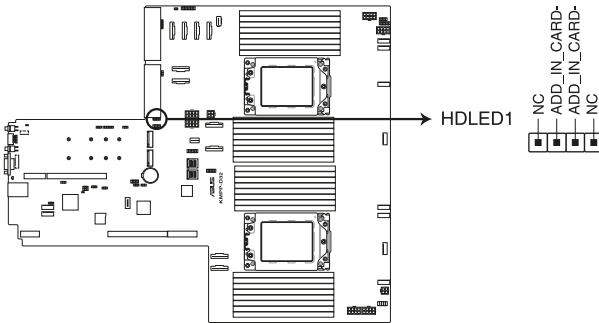

**KMPP-D32 Storage device activity LED connector**

**16. I<sup>2</sup>C connector (10-1 pin BP\_I2C1)**

This connector is used for the AMD NVME Hot plug function and for the NVME temperature read function.

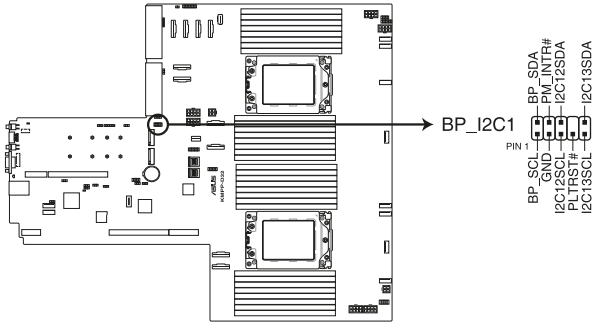

**KMPD-D32 BP\_I2C1 connector**

**17. BMC Debug UART connector (3-pin BMC\_DEBUGUART1)**

This connector is used for reading the BMC UART Debug log.

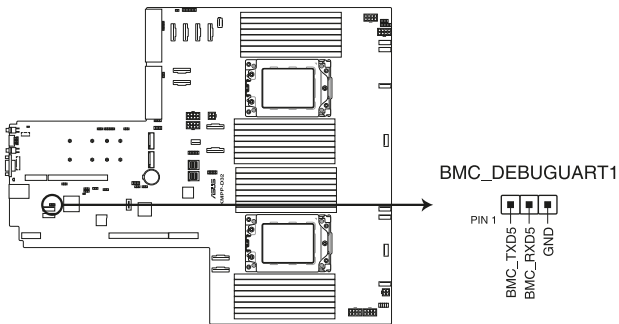

**KMPD-D32 BMC\_DEBUGUART1 connector**

**18. CPLD JTAG connector (6-pin CPLD\_JTAG1)**

This connector is used for burning the CPLD JTAG.

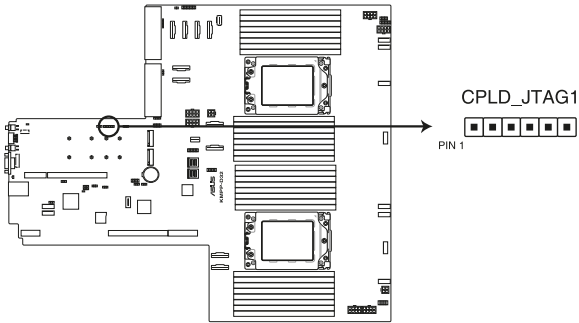

**KMPP-D32 CPLD\_JTAG1 connector**

**19. Liquid connector (12-1 pin LIQUID\_CONN1)**

This connector is used for detecting the pump speed of the water cooling system.

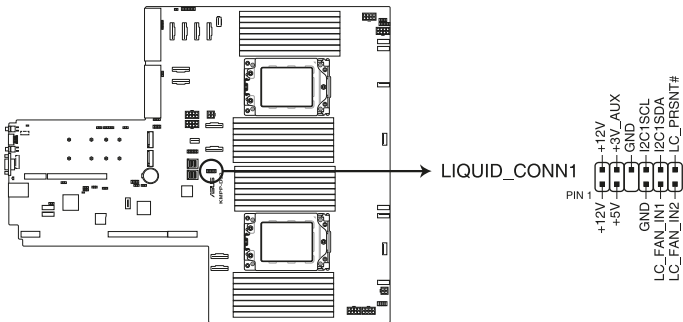

**KMPP-D32 LIQUID\_CONN1 connector**

**20. SLMPCIE SGPIO connector (6-1 pin SLMPCIE5\_SGPIO1)**

This connector is the SGPIO header for controlling the HDD LED function.

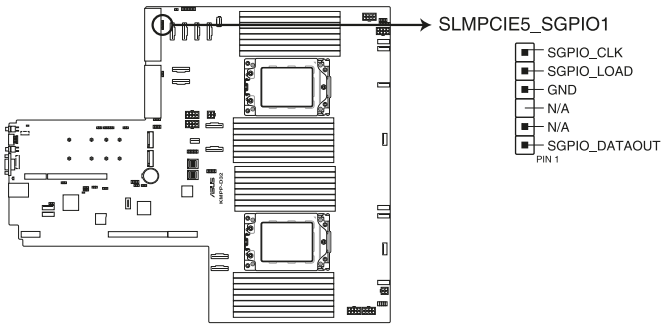

**KMPP-D32 SLMPCIE5\_SGPIO1 connector**

# **BIOS Setup**

# 5

This chapter tells how to change the system settings through the BIOS Setup menus. Detailed descriptions of the BIOS parameters are also provided.

## 5.1 Managing and updating your BIOS

The following utilities allow you to manage and update the motherboard Basic Input/Output System (BIOS) setup:

### 1. **ASUS CrashFree BIOS 3**

To recover the BIOS using a bootable USB flash disk drive when the BIOS file fails or gets corrupted.

### 2. **ASUS EzFlash**

Updates the BIOS using a USB flash disk.

### 3. **BUPDATER**

Updates the BIOS in DOS mode using a bootable USB flash disk drive.

Refer to the corresponding sections for details on these utilities.



---

Save a copy of the original motherboard BIOS file to a bootable USB flash disk drive in case you need to restore the BIOS in the future. Copy the original motherboard BIOS using the BUPDATER utility.

---

### 5.1.1 **ASUS CrashFree BIOS 3 utility**

The ASUS CrashFree BIOS 3 is an auto recovery tool that allows you to restore the BIOS file when it fails or gets corrupted during the updating process. You can update a corrupted BIOS file using a USB flash drive that contains the updated BIOS file.



---

Prepare a USB flash drive containing the updated motherboard BIOS before using this utility.

---

### **Recovering the BIOS from a USB flash drive**

To recover the BIOS from a USB flash drive:

1. Insert the USB flash drive with the original or updated BIOS file to one USB port on the system.
2. The utility will automatically recover the BIOS. It resets the system when the BIOS recovery finished.



---

**DO NOT** shut down or reset the system while recovering the BIOS! Doing so would cause system boot failure!

---



---

The recovered BIOS may not be the latest BIOS version for this motherboard. Visit the ASUS website at [www.asus.com](http://www.asus.com) to download the latest BIOS file.

---

## 5.1.2 ASUS EZ Flash Utility

The ASUS EZ Flash Utility feature allows you to update the BIOS without having to use a DOS-based utility.



Before you start using this utility, download the latest BIOS from the ASUS website at [www.asus.com](http://www.asus.com).

To update the BIOS using EZ Flash Utility:

1. Insert the USB flash disk that contains the latest BIOS file into the USB port.
2. Enter the BIOS setup program. Go to the **Tool** menu then select **Start ASUS EzFlash**. Press <Enter>.

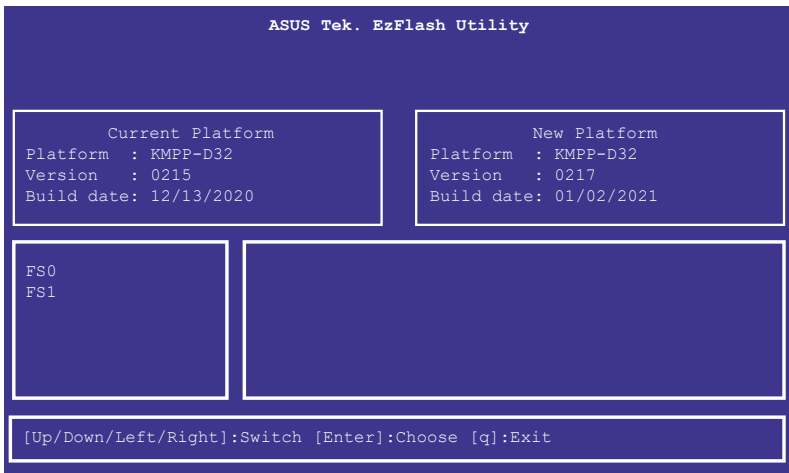

3. Press Left arrow key to switch to the **Drive** field.
4. Press the Up/Down arrow keys to find the USB flash disk that contains the latest BIOS, then press <Enter>.
5. Press Right arrow key to switch to the **Folder Info** field.
6. Press the Up/Down arrow keys to find the BIOS file, and then press <Enter> to perform the BIOS update process. Reboot the system when the update process is done.



- This function can support devices such as a USB flash disk with FAT 32/16 format and single partition only.
- DO NOT shut down or reset the system while updating the BIOS to prevent system boot failure!



Ensure to load the BIOS default settings to ensure system compatibility and stability. Press <F5> and select **Yes** to load the BIOS default settings.

### 5.1.3 BUPDATER utility



---

The succeeding BIOS screens are for reference only. The actual BIOS screen displays may not be the same as shown.

---

The BUPDATER utility allows you to update the BIOS file in the DOS environment using a bootable USB flash disk drive with the updated BIOS file.

#### Updating the BIOS file

To update the BIOS file using the BUPDATER utility:

1. Visit the ASUS website at [www.asus.com](http://www.asus.com) and download the latest BIOS file for the motherboard. Save the BIOS file to a bootable USB flash disk drive.
2. Copy the BUPDATER utility (BUPDATER.exe) from the ASUS support website at [www.asus.com/support](http://www.asus.com/support) to the bootable USB flash disk drive you created earlier.
3. Boot the system in DOS mode, then at the prompt, type:

```
BUPDATER /i[filename].CAP
```

where [filename] is the latest or the original BIOS file on the bootable USB flash disk drive, then press <Enter>.

```
A:\>BUPDATER /i[file name].CAP
```

- The utility verifies the file, then starts updating the BIOS file.

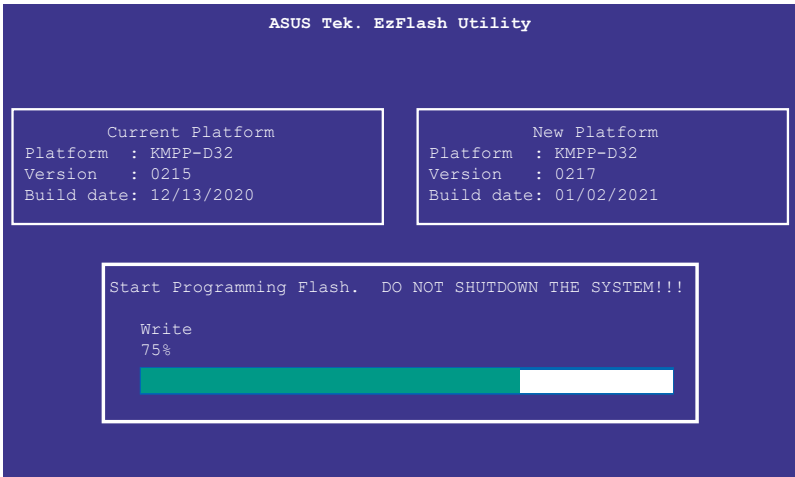

---

DO NOT shut down or reset the system while updating the BIOS to prevent system boot failure!

---

- The utility returns to the DOS prompt after the BIOS update process is completed. Reboot the system from the hard disk drive.

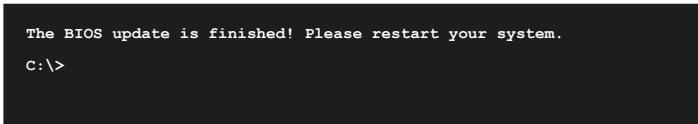

## 5.2 BIOS setup program

This motherboard supports a programmable firmware chip that you can update using the provided utility described in section **5.1 Managing and updating your BIOS**.

Use the BIOS Setup program when you are installing a motherboard, reconfiguring your system, or prompted to “Run Setup.” This section explains how to configure your system using this utility.

Even if you are not prompted to use the Setup program, you can change the configuration of your computer in the future. For example, you can enable the security password feature or change the power management settings. This requires you to reconfigure your system using the BIOS Setup program so that the computer can recognize these changes and record them in the CMOS RAM of the firmware chip.

The firmware chip on the motherboard stores the Setup utility. When you start up the computer, the system provides you with the opportunity to run this program. Press <Del> during the Power-On Self-Test (POST) to enter the Setup utility; otherwise, POST continues with its test routines.

If you wish to enter Setup after POST, restart the system by pressing <Ctrl>+<Alt>+<Delete>, or by pressing the reset button on the system chassis. You can also restart by turning the system off and then back on. Do this last option only if the first two failed.

The Setup program is designed to make it as easy to use as possible. Being a menu-driven program, it lets you scroll through the various sub-menus and make your selections from the available options using the navigation keys.



- 
- The default BIOS settings for this motherboard apply for most conditions to ensure optimum performance. If the system becomes unstable after changing any BIOS settings, load the default settings to ensure system compatibility and stability. Press <F5> and select **Yes** to load the BIOS default settings.
  - The BIOS setup screens shown in this section are for reference purposes only, and may not exactly match what you see on your screen.
  - Visit the ASUS website ([www.asus.com](http://www.asus.com)) to download the latest BIOS file for this motherboard.
-

## 5.2.1 BIOS menu screen

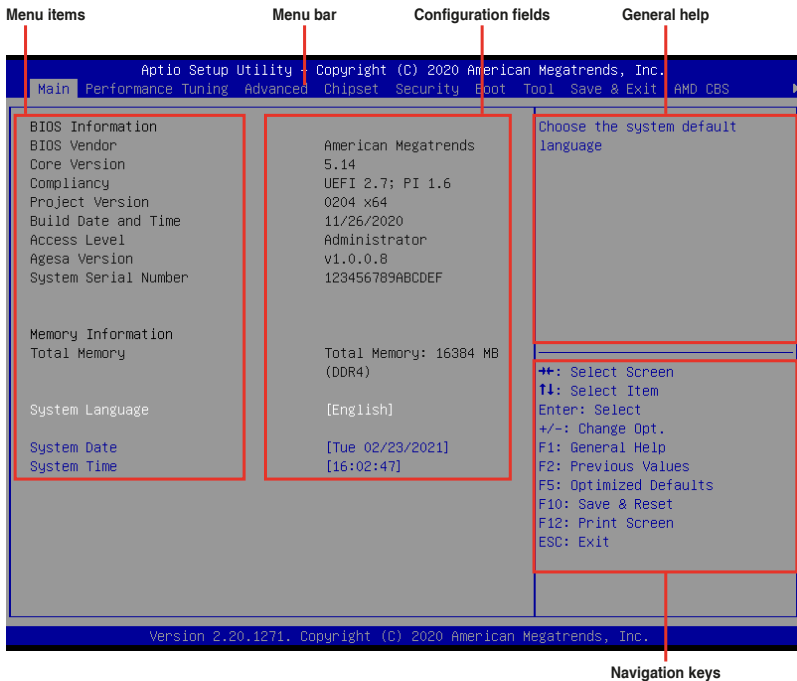

## 5.2.2 Menu bar

The menu bar on top of the screen has the following main items:

- Main** For changing the basic system configuration
- Performance Tuning** For changing the performance settings
- Advanced** For changing the advanced system settings
- Chipset** For changing the chipset settings
- Security** For changing the security settings
- Boot** For changing the system boot configuration
- Tool** For configuring options for special functions
- Save & Exit** For selecting the exit options
- AMD CBS** For configuring AMD CBS settings
- Event Logs** For changing the event log settings
- Server Mgmt** For changing the Server Mgmt settings

To select an item on the menu bar, press the right or left arrow key on the keyboard until the desired item is highlighted.

### **5.2.3 Menu items**

The highlighted item on the menu bar displays the specific items for that menu. For example, selecting **Main** shows the Main menu items.

The other items (such as **Advanced**) on the menu bar have their respective menu items.

### **5.2.4 Submenu items**

A solid triangle before each item on any menu screen means that the item has a submenu. To display the submenu, select the item then press <Enter>.

### **5.2.5 Navigation keys**

At the bottom right corner of a menu screen are the navigation keys for the BIOS setup program. Use the navigation keys to select items in the menu and change the settings.

### **5.2.6 General help**

At the top right corner of the menu screen is a brief description of the selected item.

### **5.2.7 Configuration fields**

These fields show the values for the menu items. If an item is user-configurable, you can change the value of the field opposite the item. You cannot select an item that is not user-configurable.

A configurable field is enclosed in brackets, and is highlighted when selected. To change the value of a field, select it and press <Enter> to display a list of options.

### **5.2.8 Pop-up window**

Select a menu item and press <Enter> to display a pop-up window with the configuration options for that item.

### **5.2.9 Scroll bar**

A scroll bar appears on the right side of a menu screen when there are items that do not fit on the screen. Press the Up / Down arrow keys or <Page Up> / <Page Down> keys to display the other items on the screen.

## 5.3 Main menu

When you enter the BIOS Setup program, the Main menu screen appears. The Main menu provides you an overview of the basic system information, and allows you to set the system date, time, and language settings.

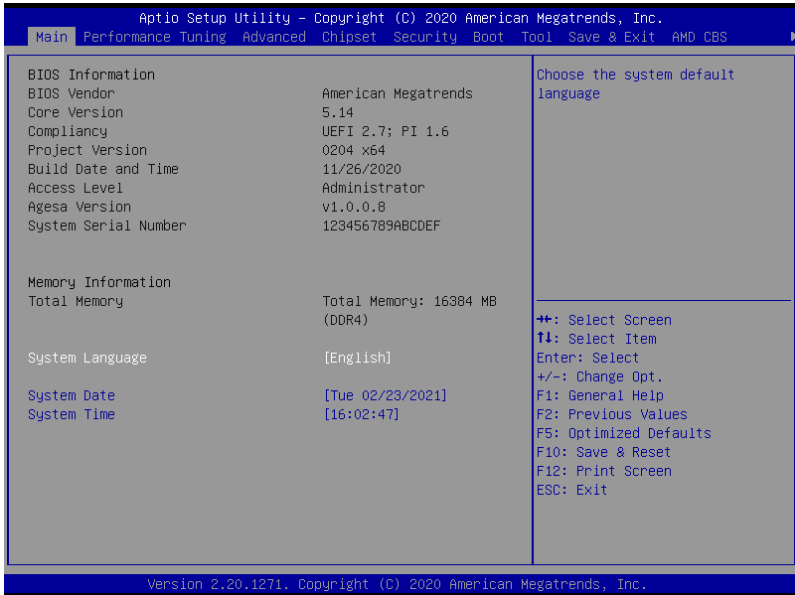

### 5.3.1 System Language [English]

Allows you to select the system default language.

### 5.3.2 System Date [Day xx/xx/xxxx]

Allows you to set the system date.

### 5.3.3 System Time [xx:xx:xx]

Allows you to set the system time.

# 5.4 Performance Tuning menu

The Performance Tuning menu items allow you to change performance related settings for different scenarios.

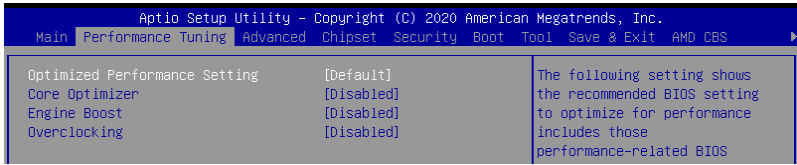

## Optimized Performance Setting [Default]

Allows you to select performance settings for different scenarios.

[Default] Default settings.

[By Benchmark] Optimize for different kinds of benchmarks. Select this option, then select a benchmark type from the >> list.

[By Workload] Optimize for different kinds of workloads. Select this option, then select a workload type from the >> list.

Configuration options:

**[Peak Frequency Optimized]** - Applies settings with performance and power consumption balance. Recommended for users that need higher performance.

**[Latency Optimized]** - Applies settings with low latency results. Recommended for latency-sensitive users.

**[Power Efficient Optimized]** - Applies settings with power efficiency. Recommended for general users.

**[HPC]** - Applies settings with optimized compute capability. Recommend for traditional HPC applications.



---

**Core Optimizer** and **Engine Boost** appear only when you set **Optimized Performance Setting** to **[Default]** or **[By Benchmark]**.

---

## Core Optimizer [Disabled]

Enable this item to keep the processor operating at the turbo frequency.

Configuration options: [Disabled] [Enabled]



---

Linux support may vary by version of the OS.

---

## Engine Boost [Disabled]

Enable this item to boost the CPU's frequency.

Configuration options: [Disabled] [Level1] [Level2] [Level3(Max)]

## Overclocking [Disabled]

Enable this item to increase the CPU's clock. Please use an external PCIe storage controller for your hard drives when enabling this feature.

Configuration options: [Disabled] [Enabled]



Operate with an ambient temperature of 25°C or lower for optimized performance.



Please note that overclocking might cause component damage or system crashes, which may reduce the lifespan of the system and the CPU. Use this tool at your own risk.

## 5.5 Advanced menu

The Advanced menu items allow you to change the settings for the CPU and other system devices.



Take caution when changing the settings of the Advanced menu items. Incorrect field values can cause the system to malfunction.

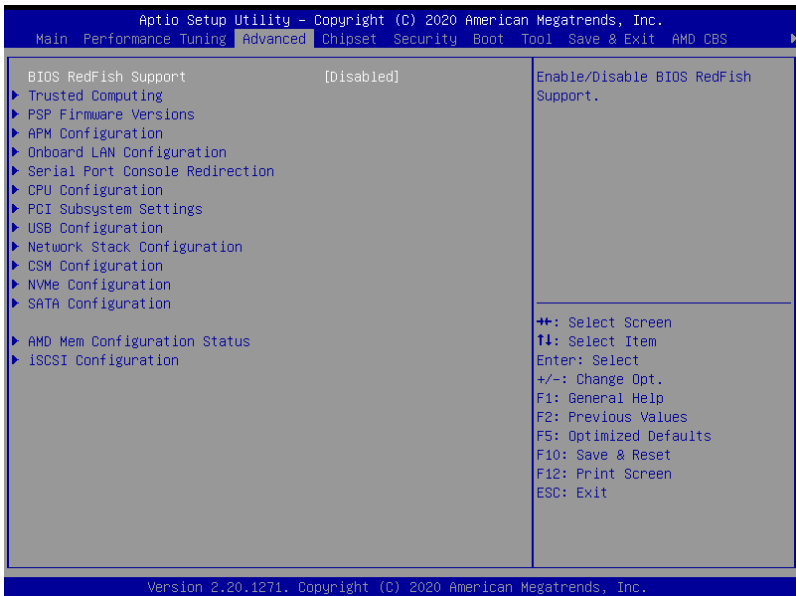

### BIOS RedFish Support [Disabled]

Allows you to enable or disable the BIOS support for RedFish.

Configuration options: [Disabled] [Enabled]

## 5.5.1 Trusted Computing

| Aptio Setup Utility - Copyright (C) 2020 American Megatrends, Inc. |            |  |
|--|------------|--|
| Advanced   |            |  |
| Configuration  |            | Enables or Disables BIOS support for security device.                                |
| Security Device Support  | [Enable]   | O.S. will not show Security Device. TCG EFI protocol and INT1A interface will not be |
| Disable Block Sid  | [Disabled] |  |
| NO Security Device Found   |            |  |

### Configuration

#### Security Device Support [Enable]

Allows you to enable or disable the BIOS support for security device. O.S. will not show Security Device. TCG EFI protocol and INT1A interface will not be available.

Configuration options: [Disable] [Enable]

#### Disable Block Sid [Disabled]

Allows you to override to allow SID authentication in TCG Storage device.

Configuration options: [Disable] [Enable]

## 5.5.2 PSP Firmware Versions

This page displays the PSP firmware versions.

| Aptio Setup Utility - Copyright (C) 2020 American Megatrends, Inc. |            |
|--|------------|
| Advanced   |            |
| PSP Firmware Versions  |            |
| PSP Directory Level 1 (Fixed)                                      |            |
| PSP Recovery BL Ver  | FF.C.0.7C  |
| SMU FW Version   | 0.36.104.0 |
| ABL Version  | 10082011   |
| PSP Directory Level 2 (Updateable)                                 |            |
| PSP BootLoader Version   | 0.C.0.7C   |
| SMU FW Version   | 0.36.104.0 |
| ABL Version  | 10082011   |

## 5.5.3 APM Configuration

Allows you to configure the Advance Power Management (APM) settings.

| Aptio Setup Utility - Copyright (C) 2020 American Megatrends, Inc. |              |                          |
|--|--------------|--------------------------|
| Advanced   |              |                          |
| Restore AC Power Loss  | [Last State] | Restore On AC Power Loss |
| Power On By PCI-E/PCI  | [Disabled]   |                          |
| Power On By RTC  | [Disabled]   |                          |

#### Restore AC Power Loss [Last State]

[Power Off] The system goes into off state after an AC power loss.

[Power On] The system will reboot after an AC power loss.

[Last State] The system goes into either off or on state, whatever the system state was before the AC power loss.

### Power On By PCI-E/PCI [Disabled]

[Disabled] Disables the PCIE devices to generate a wake event.

[Enabled] Enables the PCIE devices to generate a wake event.

### Power On By RTC [Disabled]

[Disabled] Disables RTC to generate a wake event.

[Enabled] When set to [Enabled], the items **RTC Alarm Date (Days)** and **Hour/Minute/Second** will become user-configurable with set values.

## 5.5.4 Onboard LAN Configuration

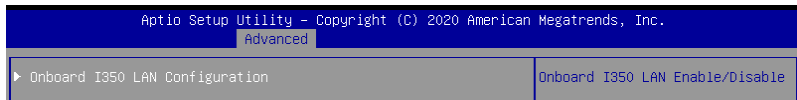

### Onboard I350 LAN Configuration

#### Intel I350 LAN1

##### LAN Enable [JumperState]

Allows you to enable or disable the Intel LAN.

Configuration options: [Disabled] [JumperState]



---

The following item appears only when **LAN Enable** is set to [JumperState].

---

##### ROM Type [PXE]

Allows you to select the Intel LAN ROM type.

Configuration options: [Disabled] [PXE] [iSCSI]

#### Intel I350 LAN2

##### LAN Enable [JumperState]

Allows you to enable or disable the Intel LAN.

Configuration options: [Disabled] [Enabled]



---

The following item appears only when **LAN Enable** is set to [JumperState].

---

##### ROM Type [Disabled]

Allows you to select the Intel LAN ROM type.

Configuration options: [Disabled] [PXE] [iSCSI]

## 5.5.5 Serial Port Console Redirection

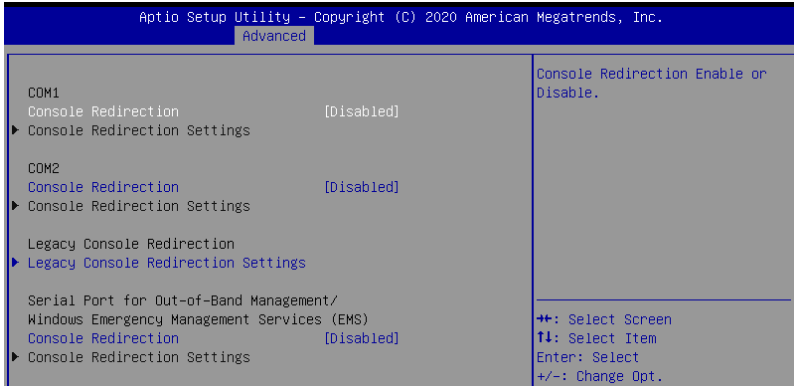

### COM1

#### Console Redirection [Disabled]

Allows you to enable or disable the console redirection feature.

Configuration options: [Disabled] [Enabled]



---

The following item appears only when **Console Redirection** is set to **[Enabled]**.

---

#### Console Redirection Settings

These items become configurable only when you enable the **Console Redirection** item. The settings specify how the host computer and the remote computer (which the user is using) will exchange data. Both computers should have the same or compatible settings.

##### Terminal Type [ANSI]

Allows you to set the terminal type.

[VT100] ASCII char set.

[VT100+] Extends VT100 to support color, function keys, etc.

[VT-UTF8] Uses UTF8 encoding to map Unicode chars onto 1 or more bytes.

[ANSI] Extended ASCII char set.

##### Bits per second [115200]

Selects serial port transmission speed. The speed must be matched on the other side. Long or noisy lines may require lower speeds.

Configuration options: [9600] [19200] [38400] [57600] [115200]

##### Data Bits [8]

Configuration options: [7] [8]

### **Parity [None]**

A parity bit can be sent with the data bits to detect some transmission errors. [Mark] and [Space] parity do not allow for error detection.

[None] None

[Even] parity bit is 0 if the num of 1's in the data bits is even

[Odd] parity bit is 0 if num of 1's in the data bits is odd

[Mark] parity bit is always 1

[Space] parity bit is always 0

### **Stop Bits [1]**

Stop bits indicate the end of a serial data packet. (A start bit indicates the beginning.) The standard setting is 1 stop bit. Communication with slow devices may require more than 1 stop bit.

Configuration options: [1] [2]

### **Flow Control [None]**

Flow control can prevent data loss from buffer overflow. When sending data, if the receiving buffers are full, a "stop" signal can be sent to stop the data flow. Once the buffers are empty, a "start" signal can be sent to re-start the flow. Hardware flow control uses two wires to send start/stop signals.

Configuration options: [None] [Hardware RTS/CTS]

### **VT -UTF8 Combo Key Support [Enabled]**

This allows you to enable the VT -UTF8 Combination Key Support for ANSI/VT100 terminals.

Configuration options: [Disabled] [Enabled]

### **Recorder Mode [Disabled]**

With this mode enabled only text will be sent. This is to capture Terminal data.

Configuration options: [Disabled] [Enabled]

### **Resolution 100x31 [Enabled]**

This allows you enable or disable extended terminal resolution.

Configuration options: [Disabled] [Enabled]

### **Putty Keypad [VT100]**

This allows you to select the FunctionKey and Keypad on Putty.

Configuration options: [VT100] [LINUX] [XTERMR6] [SCO] [ESCN] [VT400]

## **COM2**

### **Console Redirection [Disabled]**

Allows you to enable or disable the console redirection feature.

Configuration options: [Disabled] [Enabled]



---

The following item appears only when **Console Redirection** is set to **[Enabled]**.

---

### **Console Redirection Settings**

These items become configurable only when you enable the **Console Redirection** item. The settings specify how the host computer and the remote computer (which the user is using) will exchange data. Both computers should have the same or compatible settings.

#### **Terminal Type [ANSI]**

Allows you to set the terminal type.

[VT100] ASCII char set.

[VT100+] Extends VT100 to support color, function keys, etc.

[VT-UTF8] Uses UTF8 encoding to map Unicode chars onto 1 or more bytes.

[ANSI] Extended ASCII char set.

#### **Bits per second [57600]**

Selects serial port transmission speed. The speed must be matched on the other side. Long or noisy lines may require lower speeds.

Configuration options: [9600] [19200] [38400] [57600] [115200]

#### **Data Bits [8]**

Configuration options: [7] [8]

#### **Parity [None]**

A parity bit can be sent with the data bits to detect some transmission errors. [Mark] and [Space] parity do not allow for error detection.

[None] None

[Even] parity bit is 0 if the num of 1's in the data bits is even

[Odd] parity bit is 0 if num of 1's in the data bits is odd

[Mark] parity bit is always 1

[Space] parity bit is always 0

#### **Stop Bits [1]**

Stop bits indicate the end of a serial data packet. (A start bit indicates the beginning.) The standard setting is 1 stop bit. Communication with slow devices may require more than 1 stop bit.

Configuration options: [1] [2]

#### **Flow Control [None]**

Flow control can prevent data loss from buffer overflow. When sending data, if the receiving buffers are full, a "stop" signal can be sent to stop the data flow. Once the buffers are empty, a "start" signal can be sent to re-start the flow. Hardware flow control uses two wires to send start/stop signals.

Configuration options: [None] [Hardware RTS/CTS]

### **VT -UTF8 Combo Key Support [Enabled]**

This allows you to enable the VT -UTF8 Combination Key Support for ANSI/VT100 terminals.

Configuration options: [Disabled] [Enabled]

### **Recorder Mode [Disabled]**

With this mode enabled only text will be sent. This is to capture Terminal data.

Configuration options: [Disabled] [Enabled]

### **Resolution 100x31 [Enabled]**

This allows you enable or disable extended terminal resolution.

Configuration options: [Disabled] [Enabled]

### **Putty Keypad [VT100]**

This allows you to select the FunctionKey and Keypad on Putty.

Configuration options: [VT100] [LINUX] [XTERMR6] [SCO] [ESCN] [VT400]

## **Legacy Console Redirection Settings**

### **Legacy Console Redirection Port [COM1]**

Allows you to select a COM port to display redirection of Legacy OS and Legacy OPROM Messages.

Configuration options: [COM1] [COM2]

### **Resolution [80x24]**

This allows you to set the number of rows and columns supported on the Legacy OS.

Configuration options: [80x24] [80x25]

### **Redirection After POST [Always Enable]**

This setting allows you to specify if Bootloader is selected than Legacy console redirection.

Configuration options: [Always Enable] [Bootloader]

## **Serial Port for Out-of-Band Management/ Windows Emergency Management Services (EMS)**

### **Console Redirection [Disabled]**

Allows you to enable or disable the console redirection feature.

Configuration options: [Disabled] [Enabled]



---

The following item appears only when **Console Redirection** is set to **[Enabled]**.

---

### **Console Redirection Settings**

#### **Out-of-Band Mgmt Port [COM1]**

Microsoft Windows Emergency Management Services (EMS) allow for remote management of a Windows Server OS through a serial port.

Configuration options: [COM1] [COM2]

### Terminal Type [VT-UTF8]

Microsoft Windows Emergency Management Services (EMS) allow for remote management of a Windows Server OS through a serial port.  
Configuration options: [VT100] [VT100+] [VT-UTF8] [ANSI]

### Bits per second [115200]

Microsoft Windows Emergency Management Services (EMS) allow for remote management of a Windows Server OS through a serial port.  
Configuration options: [9600] [19200] [57600] [115200]

### Flow Control [None]

Microsoft Windows Emergency Management Services (EMS) allow for remote management of a Windows Server OS through a serial port.  
Configuration options: [None] [Hardware RTS/CTS] [Software Xon/Xoff]

## 5.5.6 CPU Configuration

This page displays the CPU node information.

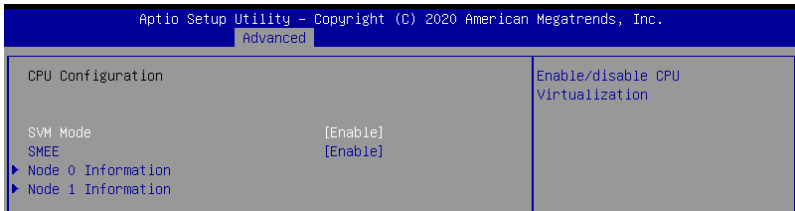

### SVM Mode [Enable]

This item allows you enable or disable CPU Virtualization.  
Configuration options: [Disabled] [Enable]

### SMEE Mode [Enable]

This item allows you to enable or disable control secure memory encryption.  
Configuration options: [Disabled] [Enable]

### Node 0 Information

This item allows you to view memory information related to Node 0.

### Node 1 Information

This item allows you to view memory information related to Node 1.

## 5.5.7 PCI Subsystem Settings

Allows you to configure PCI, PCI-X, and PCI Express Settings.

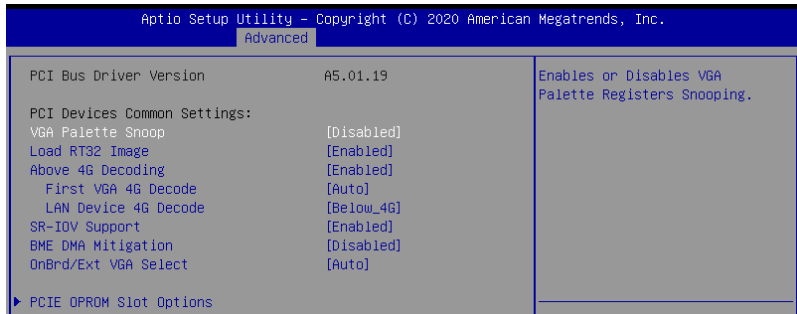

### VGA Palette Snoop [Disabled]

This option enables or disables VGA Palette Registers Snooping.

Configuration options: [Disabled] [Enabled]

### Load RT32 Image [Enabled]

This option enables or disables RT32 Image Loading.

Configuration options: [Disabled] [Enabled]

### Above 4G Decoding [Enabled]

Allows you to enable or disable 64-bit capable devices to be decoded in above 4G address space. It only works if the system supports 64-bit PCI decoding.

Configuration options: [Disabled] [Enabled]



The following items appear only when **Above 4G Decoding** is set to **[Enabled]**.

### First VGA 4G Decode [Auto]

[Auto]      Auto

[Above\_4G]      Force First VGA to above 4G

### LAN Device 4G Decode [Below\_4G]

LAN Device 4G Decode.

Configuration options: [Above\_4G] [Below\_4G]

### SR-IOV Support [Enabled]

This option enables or disables Single Root IO Virtualization Support if the system has SR-IOV capable PCIe devices.

Configuration options: [Disabled] [Enabled]

### BME DMA Mitigation [Disabled]

This allows you to enable or disable re-enabling Bus Master Attribute disabled during Pci enumeration for PCI Bridges after SMM locked.

Configuration options: [Disabled] [Enabled]

## OnBrd/Ext VGA Select [Auto]

This allows you to select between onboard or external VGA support.

Configuration options: [Auto] [Onboard] [External]

## PCIE OPROM Slot Options

### 5.5.8 USB Configuration

| Aptio Setup Utility - Copyright (C) 2020 American Megatrends, Inc. |  |
|--|--|
| Advanced   |  |
| USB Configuration  | Enables Legacy USB support. AUTO option disables legacy support if no USB devices are connected. DISABLE option will keep USB devices available only for EFI applications. |
| USB Module Version   | 24   |
| USB Controllers:   |  |
| 3 XHCIs  |  |
| USB Devices:   |  |
| 3 Drives, 2 Keyboards, 1 Mouse, 3 Hubs                             |  |
| Legacy USB Support   | [Enabled]  |
| XHCI Hand-off  | [Enabled]  |
| USB Mass Storage Driver Support                                    | [Enabled]  |
| Port 60/64 Emulation   | [Enabled]  |
| USB hardware delays and time-outs:                                 |  |
| USB transfer time-out  | [20 sec]   |
| Device reset time-out  | [20 sec]   |
| Device power-up delay  | [Auto]   |
| Mass Storage Devices:  |  |
| AMI Virtual CDROM 1.00   | [Auto]   |
| AMI Virtual HDisk 1.00   | [Auto]   |

#### Legacy USB Support [Enabled]

Allows you to enable or disable Legacy USB device support.

Configuration options: [Enabled] [Disabled] [Auto]

#### XHCI Hand-off [Enabled]

Allows you to enable or disable workaround for OSes without XHCI hand-off support. The XHCI ownership change should be claimed by XHCI driver.

Configuration options: [Enabled] [Disabled]

#### USB Mass Storage Driver Support [Enabled]

Allows you to enable or disable the USB Mass Storage driver support.

Configuration options: [Disabled] [Enabled]

#### Port 60/64 Emulation [Enabled]

Allows you to enable or disable I/O port 60h/64h emulation support. This should be enabled for the complete keyboard legacy support for non-USB aware OSes.

Configuration options: [Disabled] [Enabled]

#### USB hardware delays and time-outs

##### USB transfer time-out [20 sec]

Allows you to select time-out value for Control, Bulk, and Interrupt transfers.

Configuration options: [1 sec] [5 sec] [10 sec] [20 sec]

### Device reset time-out [20 sec]

Allows you to select time-out value for USB mass storage device Start Unit command.  
Configuration options: [10 sec] [20 sec] [30 sec] [40 sec]

### Device power-up delay [Auto]

Allows you to select maximum time the device will take before it properly reports itself to the Host Controller.

Configuration options: [Auto] [Manual]



---

The following item appears only when **Device power-up delay** is set to **[Manual]**.

---

### Device power-up delay in seconds [5]

Allows you to set the device power-up delay in seconds. Use the <+> or <-> to adjust the value. The values range from 1 to 40.

## Mass Storage Devices

Allows you to select the mass storage device emulation type for devices connected.  
Configuration options: [Auto] [Floppy] [Forced FDD] [Hard Disk] [CD-ROM]

## 5.5.9 Network Stack Configuration

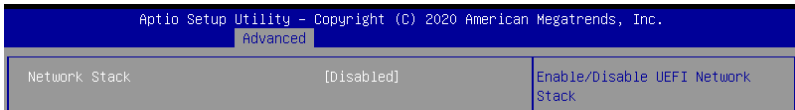

### Network stack [Disabled]

Enables or disables the network stack feature.

Configuration options: [Disable] [Enable]



---

The following item appears only when **Network stack** is set to **[Enabled]**.

---

### Ipv4 PXE Support [Disabled]

Enables or disables the Ipv4 PXE Boot Support. If disabled, Ipv4 PXE boot option will not be created.

Configuration options: [Disabled] [Enabled]

### Ipv4 HTTP Support [Disabled]

Enables or disables the Ipv4 HTTP Boot Support. If disabled, Ipv4 HTTP boot option will not be created.

Configuration options: [Disabled] [Enabled]

### Ipv6 PXE Support [Disabled]

Enables or disables the Ipv6 PXE Boot Support. If disabled, Ipv6 PXE boot option will not be created.

Configuration options: [Disabled] [Enabled]

### Ipv6 HTTP Support [Disabled]

Enables or disables the Ipv6 HTTP Boot Support. If disabled, Ipv6 HTTP boot option will not be created.

Configuration options: [Disabled] [Enabled]

### PXE boot wait time [0]

Set the wait time to press ESC key to abort the PXE boot. Use the <+> or <-> to adjust the value. The values range from 0 to 5.

### Media detect count [1]

Set the number of times presence of media will be checked. Use the <+> or <-> to adjust the value. The values range from 1 to 50.

## 5.5.10 CSM Configuration

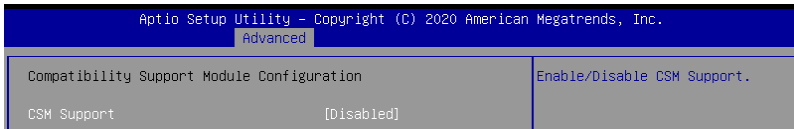

### CSM Support [Disabled]

This option allows you to enable or disable CSM Support.

Configuration options: [Disabled] [Enabled]



---

The following item appears only when **CSM Support** is set to **[Enabled]**.

---

### GateA20 Active [Upon Request]

This allows you to set the GA20 option.

Configuration options: [Upon Request] [Always]

### Option ROM Messages [Force BIOS]

This allows you to set the display mode for option ROM.

Configuration options: [Force BIOS] [Keep Current]

### INT19 Trap Response [Immediate]

The BIOS reaction on INT19 trapping by Option ROM.

[Immediate]           Execute the trap right away.

[Postponed]           Execute the trap during legacy boot.

### HDD Connection Order [Adjust]

This option allows you to select the HDD Connection Order. Some OS require HDD handles to be adjusted, i.e. OS is installed on drive 80h.

Configuration options: [Adjust] [Keep]

### Boot Option filter [UEFI and Legacy]

This option allows you to control the Legacy/UEFI ROMs priority.

Configuration options: [UEFI and Legacy] [Legacy only] [UEFI only]

### Network / Storage / Video [Legacy]

This option allows you to control the execution of UEFI and Legacy PXE / Storage / Video OpROM.

Configuration options: [UEFI] [Legacy]

### Other PCI devices [Legacy]

This item determines the OpROM execution policy for devices other than Network, Storage, or Video.

Configuration options: [UEFI] [Legacy]

## 5.5.11 NVMe Configuration

This page will display the NVMe controller and drive information.

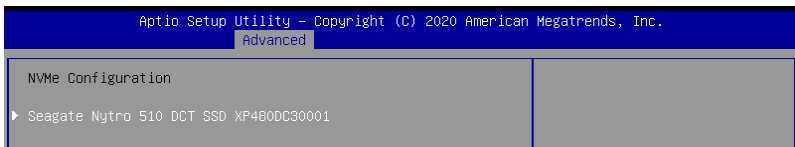

### Device



The devices and names shown in the NVMe configuration list depends on the connected devices. If no devices are connected, **No NVMe Device Found** will be displayed.

#### Self Test Option [Short]

This option allows you to select either Short or Extended Self Test. Short option will take couple of minutes, and the extended option will take several minutes to complete.

Configuration options: [Short] [Extended]

#### Self Test Action [Controller Only Test]

This item allows you to select either to test Controller alone or Controller and Namespace. Selecting Controller and Namespace option will take a lot longer to complete the test.

Configuration options: [Controller Only Test] [Controller and NameSpace Test]

#### Run Device Self Test

Press <Enter> to perform device self test for the corresponding Option and Action selected by the user. Pressing the <ESC> key will abort the test. The results shown below is the most recent result logged in the device.

## 5.5.12 SATA Configuration

This page will display the SATA controller and drive information.

Aptio Setup Utility - Copyright (C) 2020 American Megatrends, Inc.

Advanced

|                                       |             |
|---------------------------------------|-------------|
| SATA Configuration                    |             |
| SATA Controller (S:00 B:43 D:00 F:00) |             |
| ISATA1 Port1                          | Not Present |
| ISATA1 Port2                          | Not Present |
| ISATA1 Port3                          | Not Present |
| ISATA1 Port4                          | Not Present |
| ISATA2 Port1                          | Not Present |
| ISATA2 Port2                          | Not Present |
| ISATA2 Port3                          | Not Present |
| ISATA2 Port4                          | Not Present |
| SATA Controller (S:00 B:C4 D:00 F:00) |             |
| ISATA3 Port1                          | Not Present |
| ISATA3 Port2                          | Not Present |
| ISATA3 Port3                          | Not Present |
| ISATA3 Port4                          | Not Present |
| SATA Controller (S:00 B:C5 D:00 F:00) |             |
| NGFF1                                 | Not Present |
| NGFF2                                 | Not Present |

++: Select Screen  
F1: Select Item  
Enter: Select  
+/-: Change Opt.  
F1: General Help  
F2: Previous Values  
F5: Optimized Defaults  
F10: Save & Reset  
F12: Print Screen  
ESC: Exit

## 5.5.13 AMD Mem Configuration Status

The items in this menu display the memory configuration (initialized by ABL) status.

Aptio Setup Utility - Copyright (C) 2020 American Megatrends, Inc.

Advanced

|                                     |                  |   |
|-------------------------------------|------------------|---|
| ▶ Socket 0                          |                  | Socket-specific memory configuration status |
| ▶ Socket 1                          |                  |   |
| Mbist Test Enable                   | Disabled, 0xC003 |   |
| Mbist Aggressor Enable              | Disabled, 0xC000 |   |
| Mbist Per Bit Slave Die Report      | 0x0000, 0xC000   |   |
| Dram Temp Controlled Refresh Enable | Disabled, 0xC000 |   |
| User Timing Mode                    | Enabled, 0xC015  |   |
| User Timing Value                   | Enabled, 0xC015  |   |
| Mem Bus Freq Limit                  | Disabled, 0xC015 |   |
| Enable Power Down                   | Disabled, 0xC000 |   |
| Dram Double Refresh Rate            | Disabled, 0xC000 |   |
| Pmu Train Mode                      | 0x0003, 0xC000   |   |
| Ecc Symbol Size                     | 0x0002, 0xC000   |   |
| Uncorrectable Ecc Retry             | Enabled, 0xC000  |   |
| Ignore Spd Checksum                 | Enabled, 0xC000  |   |
| Enable Bank Group Swap Alt          | Enabled, 0xC000  |   |
| Enable Bank Group Swap              | Disabled, 0xC01A |   |
| Ddr Route Balanced Tee              | Disabled, 0xC000 |   |
| Nvdim Power Source                  | 0x0001, 0xC000   |   |
| Ods Cmd Throt Enable                | Disabled, 0xC004 |   |
| Ods Cmd Throt Cycle                 | Disabled, 0xC004 |   |

++: Select Screen  
F1: Select Item  
Enter: Select  
+/-: Change Opt.  
F1: General Help  
F2: Previous Values  
F5: Optimized Defaults  
F10: Save & Reset  
F12: Print Screen  
ESC: Exit

## 5.5.14 iSCSI Configuration

Allows you to configure the iSCSi parameters.

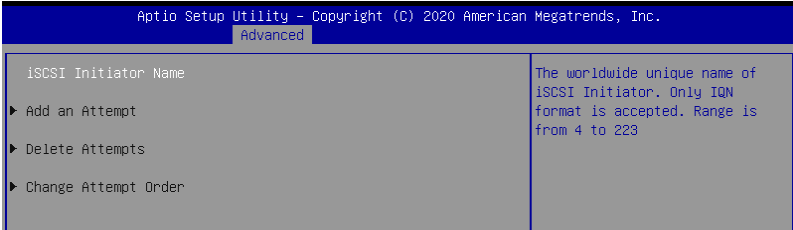

## 5.6 Chipset menu

The Chipset menu items allow you to change the Chipset settings.

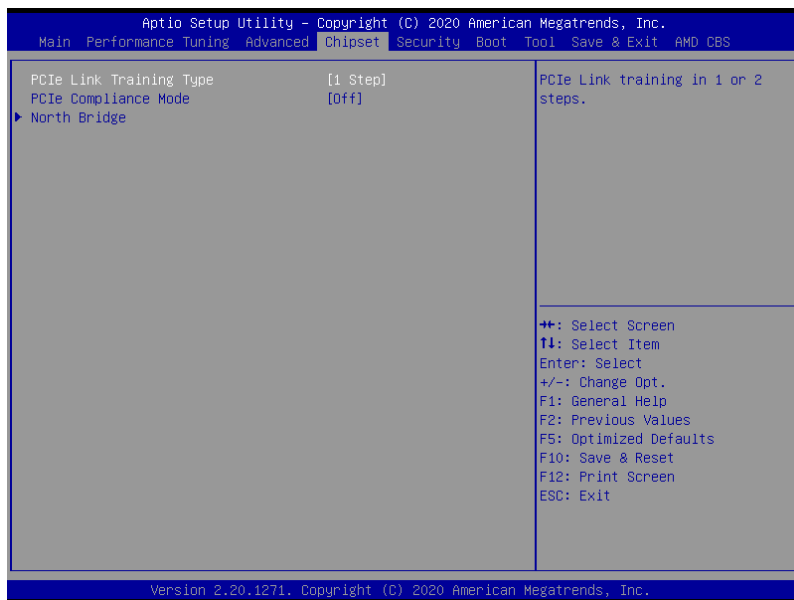

### PCIe Link Training Type [1 Step]

This item allows you to select PCIe Link Training in 1 or 2 steps.

Configuration options: [1 Step] [2 Step]

### PCIe Compliance Mode [Off]

This item allows you to turn the PCIe Compliance Mode on or off.

### North Bridge

#### Socket 0 Information

This item displays the memory information on Socket 0.

#### Socket 1 Information

This item displays the memory information on Socket 1.

## 5.7 Security menu

This menu allows a new password to be created or a current password to be changed. The menu also enables or disables the Secure Boot state and lets the user configure the System Mode state.

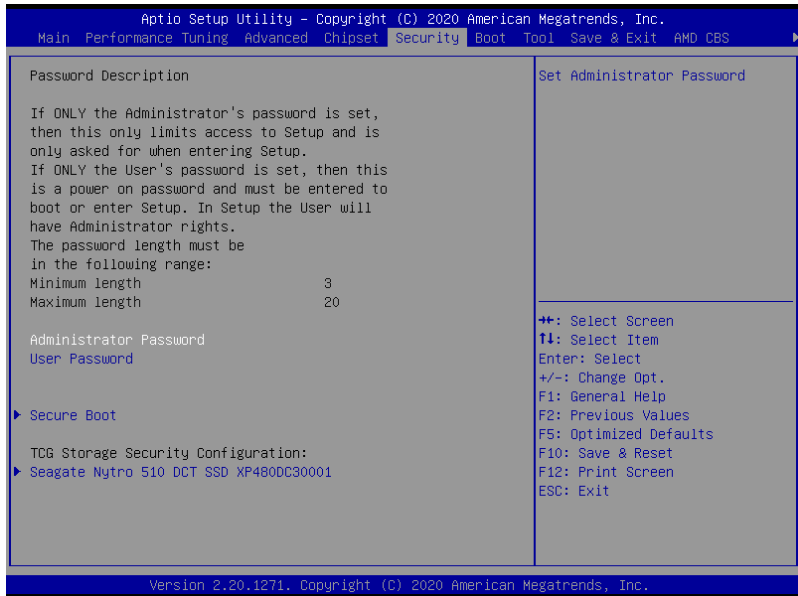

### Administrator Password

To set an administrator password:

1. Select the Administrator Password item and press <Enter>.
2. From the Create New Password box, key in a password, then press <Enter>.
3. Confirm the password when prompted.

To change an administrator password:

1. Select the Administrator Password item and press <Enter>.
2. From the Enter Current Password box, key in the current password, then press <Enter>.
3. From the Create New Password box, key in a new password, then press <Enter>.
4. Confirm the password when prompted.



---

To clear the administrator password, follow the same steps as in changing an administrator password, but press <Enter> when prompted to create/confirm the password.

---

## User Password

To set a user password:

1. Select the User Password item and press <Enter>.
2. From the Create New Password box, key in a password, then press <Enter>.
3. Confirm the password when prompted.

To change a user password:

1. Select the User Password item and press <Enter>.
2. From the Enter Current Password box, key in the current password, then press <Enter>.
3. From the Create New Password box, key in a new password, then press <Enter>.
4. Confirm the password when prompted.

To clear a user password:

1. Select the Clear User Password item and press <Enter>.
2. Select **Yes** from the Warning message window then press <Enter>.

## Secure Boot

This item allows you to customize the Secure Boot settings.

| Aptio Setup Utility - Copyright (C) 2020 American Megatrends, Inc. |                          |   |
|--|--------------------------|---|
| Security   |                          |   |
| System Mode  | User                     | Secure Boot feature is Active if Secure Boot is Enabled, Platform Key(PK) is enrolled and the System is in User mode. The mode change requires platform reset |
| Secure Boot  | [Disabled]<br>Not Active |   |
| Secure Boot Mode   | [Custom]                 |   |
| ▶ Restore Factory Keys<br>▶ Reset To Setup Mode                    |                          |   |

### Secure Boot [Disabled]

Secure Boot can be enabled if the system is running in User mode with enrolled platform Key (EPK) or if the CSM function is disabled.

Configuration options: [Disabled] [Enabled]

### Secure Boot Mode [Custom]

Allows you to set the Secure Boot selector.

Configuration options: [Custom] [Standard]



The following items are only available when **Secure Boot Mode** is set to **[Custom]**.

### Restore Factory Keys

This option will force the system to User Mode, and install factory default Secure Boot key databases.

## Reset to Setup Mode

This option will delete all Secure Boot key databases from NVRAM.

## Key Management

This item only appears when the item **Secure Boot Mode** is set to **[Custom]**. The Key Management item allows you to modify Secure Boot variables and set Key Management page.

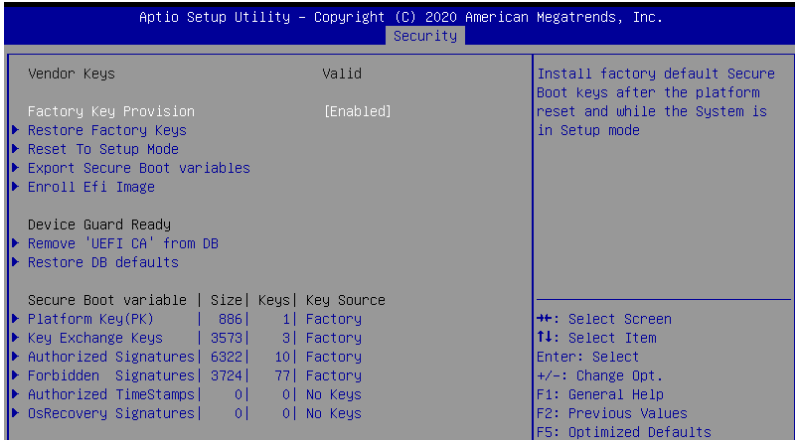

### Factory Key Provision [Disabled]

Allows you to provision factory default Secure Boot keys when the system is in Setup Mode.

Configuration options: [Disabled] [Enabled]

### Restore Factory keys

This item will install all Factory Default keys.

### Reset to Setup Mode

This item appears only when you load the default Secure Boot keys. This item allows you to clear all default Secure Boot keys.

### Export Secure Boot Variables

This item will ask you if you want to save all secure boot variables. Select Yes if you want to save all secure boot variables, otherwise select No.

### Enroll Efi Image

This item will allow the image to run in Secure Boot mode.

Configuration options: [Set New] [Append]

### Device Guard Ready

#### Remove 'UEFI CA' from DB

Remove Microsoft UEFI CA from Secure Boot DB.

**Restore DB defaults**

Restore DB variable to factory defaults.

**Platform Key (PK)**

Configuration options: [Details] [Export] [Update] [Delete]

**Key Exchange Keys (KEK) / Authorized Signatures (DB) / Forbidden Signatures (DBX)**

Configuration options: [Details] [Export] [Update] [Append] [Delete]

**Authorized TimeStamps (DBT) / OsRecovery Signatures**

Configuration options: [Update] [Append]

## 5.8 Boot menu

The Boot menu items allow you to change the system boot options.

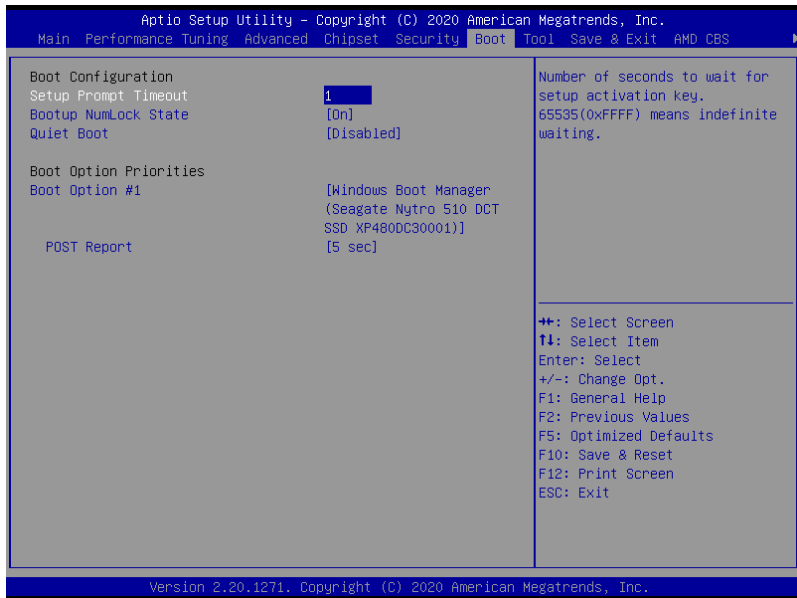

### Setup Prompt Timeout [1]

Allows you to set the number of seconds that the firmware waits before initiating the original default boot selection. 65535(0xFFFF) means indefinite waiting. Use the <+> or <-> to adjust the value.

### Bootup NumLock State [On]

Allows you to select the power-on state for the NumLock.  
Configuration options: [Off] [On]

### Quiet Boot [Disabled]

Allows you to enable or disable Quiet Boot option.  
Configuration options: [Disabled] [Enabled]

### Boot Option Priorities

These items specify the boot device priority sequence from the available devices. The number of device items that appears on the screen depends on the number of devices installed in the system.



- To select the boot device during system startup, press <F8> when ASUS Logo appears.
- To access Windows OS in Safe Mode, please press <F8> after POST.

### POST Report [5 sec]

Allows you to set the desired POST Report waiting time from 1 to 10 seconds.  
Configuration options: [1 sec] ~ [10 sec] [Until Press ESC]

## 5.9 Tool menu

The Tool menu items allow you to configure options for special functions. Select an item then press <Enter> to display the submenu.



### IPMI HWM

Allows you to run the IPMI hardware monitor.

### Start ASUS EzFlash

Allows you to run ASUS EzFlash BIOS ROM Utility when you press <Enter>. Refer to the ASUS EzFlash Utility section for details.

## 5.10 Save & Exit menu

The Exit menu items allow you to save or discard your changes to the BIOS items.

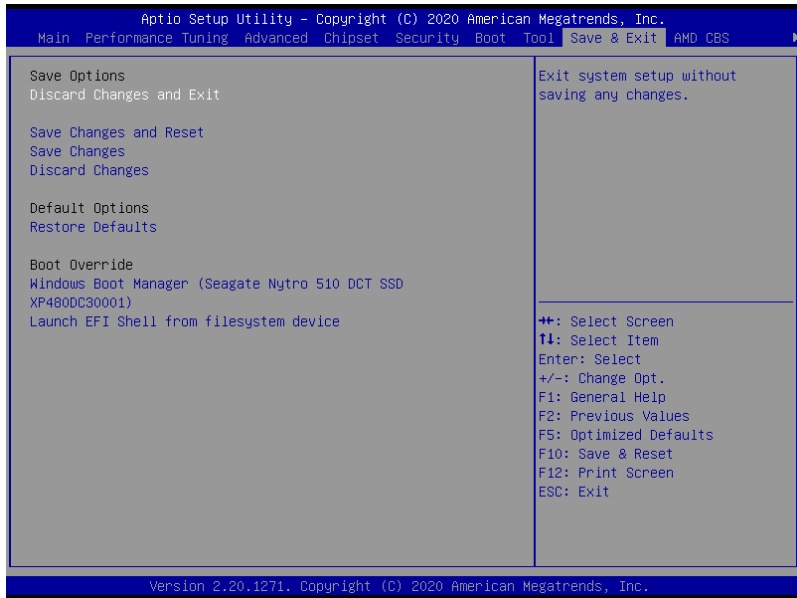

Pressing <Esc> does not immediately exit this menu. Select one of the options from this menu or <F10> from the legend bar to exit.

### Discard Changes and Exit

Exit system setup without saving any changes.

### Save Changes and Reset

Reset system after saving the changes.

### Save Changes

Save changes done so far to any of the setup options.

### Discard Changes

Discard changes done so far to any of the setup options.

### Restore Defaults

Restore/load default values for all the setup options.

### Boot Override

These items displays the available devices. The device items that appears on the screen depends on the number of devices installed in the system. Click an item to start booting from the selected device.

# 5.11 AMD CBS menu

The items in this menu shows the AMD Common BIOS Specifications.



The **AMD CBS** menu will appear under the **Advanced** menu for AMD EPIC™ 7003 Series processors.

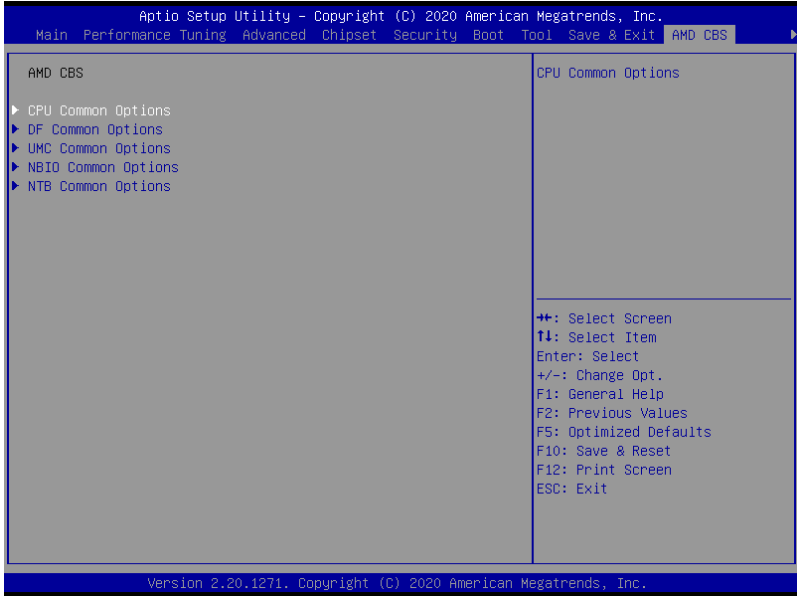

## 5.11.1 CPU Common Options

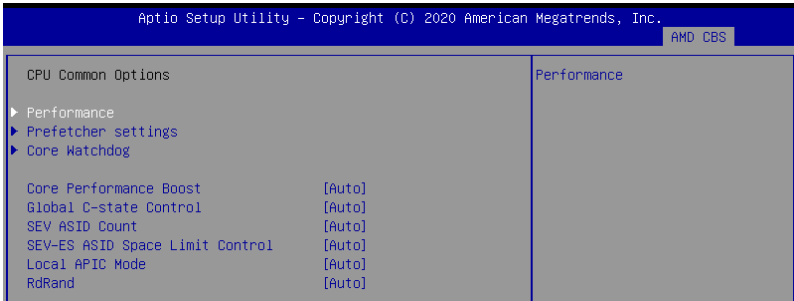

### Performance

#### Custom Core Pstates

This option allows you to enable Core Pstates. Read the disclaimer and select **I Accept** to continue.



---

Damage caused by use of your AMD processor outside of specification or in excess of factory settings are not covered by your system manufacturers warranty.

---



---

The following items appear only when **[Accept]** is selected for **Custom Core Pstates**.

---

### **Custom Pstate0 [Auto]**

Configuration options: [Auto] [Custom]



---

The following items appear only when **Custom Pstate0** is set to **[Custom]**.

---

#### ***Pstate0 FID [74]***

Specifies the core frequency multiplier. COF = 200MHz 2 FID / DID.

#### ***Pstate0 DID [8]***

Specifies the core frequency divisor (DID[0] should zero is DID[5:0]>1Ah).

#### ***Pstate0 VID [48]***

Specifies the core voltage.

### **Custom Pstate1 [Auto]**

Configuration options: [Auto] [Custom] [Disabled]



---

The following items appear only when **Custom Pstate1** is set to **[Custom]**.

---

#### ***Pstate1 FID [64]***

Specifies the core frequency multiplier. COF = 200MHz 2 FID / DID.

#### ***Pstate1 DID [a]***

Specifies the core frequency divisor (DID[0] should zero is DID[5:0]>1Ah).

#### ***Pstate1 VID [58]***

Specifies the core voltage.



---

The following item is only available when **Custom Pstate1** is set to **[Custom]** or **[Auto]**.

---

### **Custom Pstate2 [Auto]**

Configuration options: [Auto] [Custom] [Disabled]



---

The following items appear only when **Custom Pstate2** is set to **[Custom]**.

---

#### ***Pstate2 FID [5a]***

Specifies the core frequency multiplier. COF = 200MHz 2 FID / DID.

#### ***Pstate2 DID [c]***

Specifies the core frequency divisor (DID[0] should zero is DID[5:0]>1Ah).

#### ***Pstate2 VID [68]***

Specifies the core voltage.

### **CCD/Core/Thread Enhancement**

This option allows you to enable CCD/Core/Thread Enablement. Read the disclaimer and select **I Accept** to continue.



---

S3 is not supported on systems where cores/threads have been removed/disabled.

---



---

The following items appear only when **[Accept]** is selected for **CCD/Core/Thread Enhancement**.

---

#### **CCD Control [Auto]**

Sets the number of CCDs to be used. Once this option has been used to remove any CCDs, a POWER CYCLE is required in order for future selections to take effect.

Configuration options: [Auto] [2 CCDs] [3 CCDs] [4 CCDs] [6 CCDs]

#### **Core Control [Auto]**

Sets the number of cores to be used. Once this option has been used to remove any cores, a POWER CYCLE is required in order for future selections to take effect.

Configuration options: [Auto] [TWO (1 + 1)] [FOUR (2 + 2)] [SIX (3 + 3)]

#### **SMT Control [Auto]**

Can be used to disable symmetric multithreading. To re-enable SMT, a POWER CYCLE is needed after selecting the **[Auto]** option.

Configuration options: [Auto] [Disable]



---

S3 is not supported on systems where cores/threads have been removed/disabled.

---

## **Prefetcher settings**

### **L1 Stream HW Prefetcher [Auto]**

This item allows you to enable or disable L1 Stream HW Prefetcher.

Configuration options: [Disable] [Enable] [Auto]

### **L2 Stream HW Prefetcher [Auto]**

This item allows you to enable or disable L2 Stream HW Prefetcher.

Configuration options: [Disable] [Enable] [Auto]

## **Core Watchdog**

### **Core Watchdog Timer Enable [Auto]**

This item allows you to enable or disable CPU Watchdog Timer.

Configuration options: [Disable] [Enable] [Auto]



---

The following items are only available when **Core Watchdog Timer Enable** is set to **[Enabled]**.

---

### **Core Watchdog Timer Interval [Auto]**

Configuration options: [21.461s] [10.730s] [5.364s] [2.681s] [1.340s] [669.41ms] [334.05ms] [166.37ms] [82.53ms] [40.61ms] [20.970ms] [10.484ms] [5.241ms] [2.620ms] [1.309ms] [654.08us] [326.4us] [162.56us] [80.64us] [39.68us] [Auto]

### **Core Watchdog Timer Severity [Auto]**

Configuration options: [No Error] [Transparent] [Corrected] [Deferred] [Uncorrected] [Fatal] [Auto]

## **Core Performance Boost [Auto]**

This option allows you to enable or disable CPB.

Configuration options: [Disabled] [Auto]

### **Global C-state Control [Auto]**

This option allows you to control IO based C-state generation and DF C-states.  
Configuration options: [Disabled] [Enabled] [Auto]

### **SEV ASID Count [Auto]**

This field specifies the maximum valid ASID, which affects the maximum system physical address space. 16TB of physical address space is available for systems that support 253 ASIDs, while 8TB of physical address space is available for systems that support 509 ASIDs.  
Configuration options: [253 ASIDs] [509 ASIDs] [Auto]

### **SEV-ES ASID Space Limit Control [Auto]**

Configuration options: [Auto] [Manual]



---

The following item appears only when **SEV-ES ASID Space Limit Control** is set to **[Manual]**.

---

#### **SEV-ES ASID Space Limit [1]**

SEV Vms using ASIDs below the SEV-ES ASID Space Limit must enable the SEV-ES feature. ASIDs from SEV-ES ASID Space Limit to (SEV ASID Count + 1) can only be used with SEV VMs. If this field is set to (SEV ASID Count + 1), all ASIDs are forced to be SEV-ES ASIDs. Hence, the valid values for this field is 1 - (SEV ASID Count + 1).

Configuration options: [1] – [520]

### **Local APIC Mode [Auto]**

Configuration options: [XAPIC] [X2APIC] [Auto]

### **RdRand [Auto]**

This option allows you to disable RdRand instruction.

Configuration options: [Auto] [Enable] [Disable]

## 5.11.2 DF Common Options

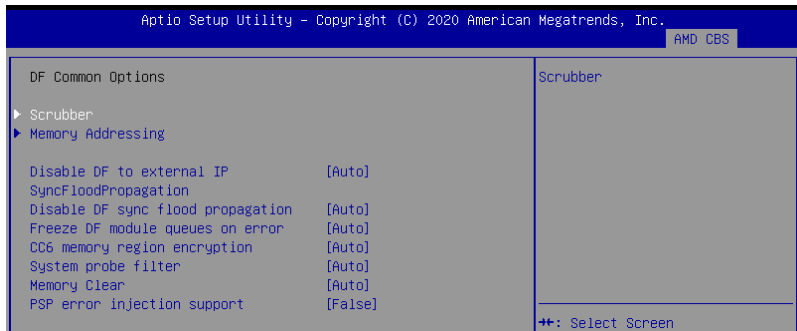

### Scrubber

#### DRAM scrub time [Auto]

This item allows you to set a number of hours to scrub memory.

Configuration options: [Disabled] [1 hour] [4 hours] [8 hours] [16 hours] [24 hours] [48 hours] [Auto]

#### Poison scrubber control [Auto]

Configuration options: [Disabled] [Enabled] [Auto]

#### Redirect scrubber control [Auto]

Configuration options: [Disabled] [Enabled] [Auto]

#### Redirect scrubber limit [Auto]

Configuration options: [2] [4] [8] [Infinite] [Auto]

#### Periodic Directory Rinse [Auto]

Configuration options: [Disabled] [Enabled] [Auto]

### Memory Addressing

#### NUMA nodes per socket [Auto]

Specifies the number of desired NUMA nodes per socket. Zero will attempt to interleave the two sockets together.

Configuration options: [NPS0] [NPS1] [NPS2] [NPS4] [Auto]

#### Memory interleaving [Auto]

This item allows for disabling memory interleaving. Note that NUMA nodes per socket will be honored regardless of this setting.

Configuration options: [Disabled] [Auto]

#### Memory interleaving size [Auto]

This item controls the memory interleaving size. The valid values are AUTO, 256 bytes, 512 bytes, 1 Kbytes, or 2 Kbytes. This also determines the starting address of the interleave (bit 8, 9, 10, or 11).

Configuration options: [256 Bytes] [512 Bytes] [1 KB] [2 KB] [Auto]

### **1TB remap [Auto]**

Attempt to remap DRAM out of the space just below the 1TB boundary. The ability to remap depends on DRAM configuration, NPS, and interleaving selection, and may not always be possible.

Configuration options: [Do not remap] [Attempt to remap] [Auto]

### **DRAM map inversion [Auto]**

Inverting the map will cause the highest memory channels to get assigned the lowest addresses in the system.

Configuration options: [Disabled] [Enabled] [Auto]

### **Location of private memory regions [Auto]**

Controls whether or not the private memory regions (PSP, SMU, and CC6) are at the top of DRAM or distributed. Note that distributed requires memory on all dies. Note that it will always be at the top of DRAM id some dies don't have memory regardless of this option's setting.

Configuration options: [Distributed] [Consolidated] [Auto]

### **Disable DF to external IP SyncFloodPropagation [Auto]**

This item allows you to disable SyncFlood to UMC & downstream slaves.

Configuration options: [Sync flood disabled] [Sync flood enabled] [Auto]

### **Disable DF sync flood propagation [Auto]**

Configuration options: [Sync flood disabled] [Sync flood enabled] [Auto]

### **Freeze DF module queues on error [Auto]**

Configuration options: [Disabled] [Enabled] [Auto]

### **CC6 memory region encryption [Auto]**

This item allows you to control whether or not the CC6 save/restore memory is encrypted.

Configuration options: [Disabled] [Enabled] [Auto]

### **System probe filter [Auto]**

This item allows you to enable or disable the probe filter. This has no effect on parts where the probe filter is fuse disabled.

Configuration options: [Disabled] [Enabled] [Auto]

### **Memory Clear [Auto]**

When this item is set to **[Disabled]**, BIOS does not implement MemClear after memory training (only if non-ECC DIMMs are used).

Configuration options: [Disabled] [Enabled] [Auto]

### **PSP error injection support [False]**

Configuration options: [False] [True]

## 5.11.3 UMC Common Option

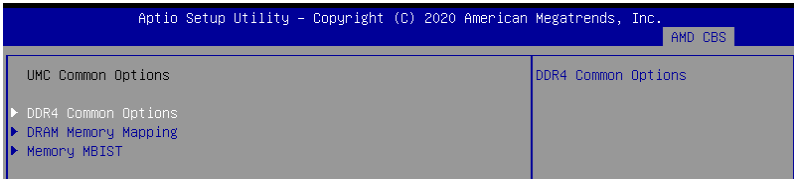

### DDR4 Common Options

#### DRAM Timing Configuration

This item allows you to enable DRAM timing configuration.



Damage caused by use of your AMD processor outside of specification or in excess of factory settings are not covered by your system manufacturers warranty.



The following items appear only when **[Accept]** is selected for **DRAM Timing Configuration**.

#### **Overclock [Auto]**

Configuration options: [Auto] [Enabled]



The following items appear only when **Overclock** is set to **[Enabled]**.

#### **Memory Clock Speed [Auto]**

Specifies the memory clock frequency.

Configuration options: [Auto] [667MHz] [800MHz] [933MHz] [1067MHz] [1200MHz] [1333MHz] [1467MHz] [1600MHz]

#### **Tcl [Auto]**

Specifies the CAS latency.

Configuration options: [Auto] [8 Clk] [9 Clk] [0Ah Clk] [0Bh Clk] [0Ch Clk] [0Dh Clk] [0Eh Clk] [0Fh Clk] [10h Clk] [11h Clk] [12h Clk] [13h Clk] [14h Clk] [15h Clk] [16h Clk] [17h Clk] [18h Clk] [19h Clk] [1Ah Clk] [1Bh Clk] [1Ch Clk] [1Dh Clk] [1Eh Clk] [1Fh Clk] [20h Clk] [21h Clk]

#### **Trcdrd [Auto]**

Specifies the RAS# Active to CAS# Read Delay Time.

Configuration options: [Auto] [8 Clk] [9 Clk] [0Ah Clk] [0Bh Clk] [0Ch Clk] [0Dh Clk] [0Eh Clk] [0Fh Clk] [10h Clk] [11h Clk] [12h Clk] [13h Clk] [14h Clk] [15h Clk] [16h Clk] [17h Clk] [18h Clk] [19h Clk] [1Ah Clk] [1Bh Clk]

#### **Trcdwr [Auto]**

Specifies the RAS# Active to CAS# Write Delay Time.

Configuration options: [Auto] [8 Clk] [9 Clk] [0Ah Clk] [0Bh Clk] [0Ch Clk] [0Dh Clk] [0Eh Clk] [0Fh Clk] [10h Clk] [11h Clk] [12h Clk] [13h Clk] [14h Clk] [15h Clk] [16h Clk] [17h Clk] [18h Clk] [19h Clk] [1Ah Clk] [1Bh Clk]

**Trp [Auto]**

Specifies the Row Precharge Delay Time.

Configuration options: [Auto] [8 Clk] [9 Clk] [0Ah Clk] [0Bh Clk] [0Ch Clk] [0Dh Clk] [0Eh Clk] [0Fh Clk] [10h Clk] [11h Clk] [12h Clk] [13h Clk] [14h Clk] [15h Clk] [16h Clk] [17h Clk] [18h Clk] [19h Clk] [1Ah Clk] [1Bh Clk]

**Tras [Auto]**

Specifies the Active to Precharge Delay Time.

Configuration options: [Auto] [15h Clk] [16h Clk] [17h Clk] [18h Clk] [19h Clk] [1Ah Clk] [1Bh Clk] [1Ch Clk] [1Dh Clk] [1Eh Clk] [1Fh Clk] [20h Clk] [21h Clk] [22h Clk] [23h Clk] [24h Clk] [25h Clk] [26h Clk] [27h Clk] [28h Clk] [29h Clk] [2Ah Clk] [2Bh Clk] [2Ch Clk] [2Dh Clk] [2Eh Clk] [2Fh Clk] [30h Clk] [31h Clk] [32h Clk] [33h Clk] [34h Clk] [35h Clk] [36h Clk] [37h Clk] [38h Clk] [39h Clk] [3Ah Clk]

**Trc Ctrl [Auto]**

Specifies Trc.

Configuration options: [Auto] [Manual]



---

The following item appears only when **Trc Ctrl** is set to **[Manual]**.

---

**Trc [39]**

Specifies Active to Active/Refresh Delay Time. Valid values 87h-1Dh.

**TrrdS [Auto]**

Specifies the Activate to Activate Delay Time, different back group (tRRD\_S).

Configuration options: [Auto] [4 Clk] [5 Clk] [6 Clk] [7 Clk] [8 Clk] [9 Clk] [0Ah Clk] [0Bh Clk] [0Ch Clk]

**TrrdL [Auto]**

Specifies the Activate to Activate Delay Time, same back group (tRRD\_L).

Configuration options: [Auto] [4 Clk] [5 Clk] [6 Clk] [7 Clk] [8 Clk] [9 Clk] [0Ah Clk] [0Bh Clk] [0Ch Clk]

**Tfaw Ctrl [Auto]**

Specifies Tfaw.

Configuration options: [Auto] [Manual]



---

The following item appears only when **Tfaw Ctrl** is set to **[Manual]**.

---

**Tfaw [1a]**

Specifies the Four Activate Window Time. Valid values 36h-6h.

**TwtrS [Auto]**

Specifies the Minimum Write to Read Time, different bank group.

Configuration options: [Auto] [2 Clk] [3 Clk] [4 Clk] [5 Clk] [6 Clk] [7 Clk] [8 Clk] [9 Clk] [0Ah Clk] [0Bh Clk] [0Ch Clk] [0Dh Clk] [0Eh Clk]

**TwtrL [Auto]**

Specifies the Minimum Write to Read Time, same bank group.

Configuration options: [Auto] [2 Clk] [3 Clk] [4 Clk] [5 Clk] [6 Clk] [7 Clk] [8 Clk] [9 Clk] [0Ah Clk] [0Bh Clk] [0Ch Clk] [0Dh Clk] [0Eh Clk]

***Twr Ctrl [Auto]***

Specifies Twr.

Configuration options: [Auto] [Manual]

---



The following item appears only when **Twr Ctrl** is set to **[Manual]**.

---

***Twr [12]***

Specifies the Minimum Write Recovery Time. Valid values 51h-Ah.

***Trcpage Ctrl [Auto]***

Specifies Trcpage.

Configuration options: [Auto] [Manual]

---



The following item appears only when **Trcpage Ctrl** is set to **[Manual]**.

---

***Trcpage [0]***

SDRAM Optional Features (tMAW MAC). Valid values 3FFh-0h.

***TrdrdScL Ctrl [Auto]***

Specifies TrdrdScL.

Configuration options: [Auto] [Manual]

---



The following item appears only when **TrdrdScL Ctrl** is set to **[Manual]**.

---

***TrdrdScL [3]***

Specifies the CAS to CAS Delay Time, same bank group. Valid values Fh-1h.

***TwrwrScL Ctrl [Auto]***

Specifies TwrwrScL.

Configuration options: [Auto] [Manual]

---



The following item appears only when **TwrwrScL Ctrl** is set to **[Manual]**.

---

***TwrwrScL [3]***

Specifies the CAS to CAS Delay Time, same bank group. Valid values 3Fh-1h.

***Trfc Ctrl [Auto]***

Specifies Trfc.

Configuration options: [Auto] [Manual]

---



The following item appears only when **Trfc Ctrl** is set to **[Manual]**.

---

***Trfc [138]***

Specifies the Refresh Recovery Delay Time (tRFC1). Valid values 3DEh-3Ch.

***Trfc2 Ctrl [Auto]***

Specifies Trfc2.

Configuration options: [Auto] [Manual]



---

The following item appears only when **Trfc2 Ctrl** is set to **[Manual]**.

---

**Trfc2 [c0]**

Specifies the Refresh Recovery Delay Time (tRFC2). Valid values 3DEh-3Ch.

**Trfc4 Ctrl [Auto]**

Specifies Trfc4.

Configuration options: [Auto] [Manual]

---



The following item appears only when **Trfc4 Ctrl** is set to **[Manual]**.

---

**Trfc4 [84]**

Specifies the Refresh Recovery Delay Time (tRFC4). Valid values 3DEh-3Ch.

**Tcwl [Auto]**

Specifies the CAS Write Latency.

Configuration options: [Auto] [9 Clk] [0Ah Clk] [0Bh Clk] [0Ch Clk] [0Eh Clk] [10h Clk] [12h Clk] [14h Clk]

**Trtp [Auto]**

Specifies the Read CAS# to Precharge Delay Time.

Configuration options: [Auto] [5 Clk] [6 Clk] [7 Clk] [8 Clk] [9 Clk] [0Ah Clk] [0Bh Clk] [0Ch Clk] [0Dh Clk] [0Eh Clk]

**Tcke [Auto]**

Specifies the CKE minimum high and low pulse width in memory clock cycles.

Configuration options: [Auto] [1 Clk] [2 Clk] [3 Clk] [4 Clk] [5 Clk] [6 Clk] [7 Clk] [8 Clk] [9 Clk] [0Ah Clk] [0Bh Clk] [0Ch Clk] [0Dh Clk] [0Eh Clk] [0Fh Clk] [10h Clk] [11h Clk] [12h Clk] [13h Clk] [14h Clk] [15h Clk] [16h Clk] [17h Clk] [18h Clk] [19h Clk] [1Ah Clk] [1Bh Clk] [1Ch Clk] [1Dh Clk] [1Eh Clk] [1Fh Clk]

**Trdwr [Auto]**

Specifies the Read to Write turnaround timing.

Configuration options: [Auto] [1 Clk] [2 Clk] [3 Clk] [4 Clk] [5 Clk] [6 Clk] [7 Clk] [8 Clk] [9 Clk] [0Ah Clk] [0Bh Clk] [0Ch Clk] [0Dh Clk] [0Eh Clk] [0Fh Clk] [10h Clk] [11h Clk] [12h Clk] [13h Clk] [14h Clk] [15h Clk] [16h Clk] [17h Clk] [18h Clk] [19h Clk] [1Ah Clk] [1Bh Clk] [1Ch Clk] [1Dh Clk] [1Eh Clk] [1Fh Clk]

**Twrrd [Auto]**

Specifies the Write to Read turnaround timing.

Configuration options: [Auto] [1 Clk] [2 Clk] [3 Clk] [4 Clk] [5 Clk] [6 Clk] [7 Clk] [8 Clk] [9 Clk] [0Ah Clk] [0Bh Clk] [0Ch Clk] [0Dh Clk] [0Eh Clk] [0Fh Clk]

**TwrrwSc [Auto]**

Specifies the Write to Write turnaround timing in the same chipselect.

Configuration options: [Auto] [1 Clk] [2 Clk] [3 Clk] [4 Clk] [5 Clk] [6 Clk] [7 Clk] [8 Clk] [9 Clk] [0Ah Clk] [0Bh Clk] [0Ch Clk] [0Dh Clk] [0Eh Clk] [0Fh Clk]

***TwrrSd [Auto]***

Specifies the Write to Write turnaround timing in the same DIMM.  
 Configuration options: [Auto] [1 Clk] [2 Clk] [3 Clk] [4 Clk] [5 Clk] [6 Clk] [7 Clk] [8 Clk] [9 Clk] [0Ah Clk] [0Bh Clk] [0Ch Clk] [0Dh Clk] [0Eh Clk] [0Fh Clk]

***TwrrDd [Auto]***

Specifies the Write to Write turnaround timing in a different DIMM.  
 Configuration options: [Auto] [1 Clk] [2 Clk] [3 Clk] [4 Clk] [5 Clk] [6 Clk] [7 Clk] [8 Clk] [9 Clk] [0Ah Clk] [0Bh Clk] [0Ch Clk] [0Dh Clk] [0Eh Clk] [0Fh Clk]

***TrdrSc [Auto]***

Specifies the Read to Read turnaround timing in the same chipselect.  
 Configuration options: [Auto] [1 Clk] [2 Clk] [3 Clk] [4 Clk] [5 Clk] [6 Clk] [7 Clk] [8 Clk] [9 Clk] [0Ah Clk] [0Bh Clk] [0Ch Clk] [0Dh Clk] [0Eh Clk] [0Fh Clk]

***TrdrSd [Auto]***

Specifies the Read to Read turnaround timing in the same DIMM.  
 Configuration options: [Auto] [1 Clk] [2 Clk] [3 Clk] [4 Clk] [5 Clk] [6 Clk] [7 Clk] [8 Clk] [9 Clk] [0Ah Clk] [0Bh Clk] [0Ch Clk] [0Dh Clk] [0Eh Clk] [0Fh Clk]

***TrdrDd [Auto]***

Specifies the Read to Read turnaround timing in a different DIMM.  
 Configuration options: [Auto] [1 Clk] [2 Clk] [3 Clk] [4 Clk] [5 Clk] [6 Clk] [7 Clk] [8 Clk] [9 Clk] [0Ah Clk] [0Bh Clk] [0Ch Clk] [0Dh Clk] [0Eh Clk] [0Fh Clk]

***ProcODT [Auto]***

Specifies the Processor ODT.  
 Configuration options: [Auto] [High Impedance] [480 ohm] [240 ohm] [160 ohm] [120 ohm] [96 ohm] [80 ohm] [68.6 ohm] [60 ohm] [53.3 ohm] [48 ohm] [43.6 ohm] [40 ohm] [36.9 ohm] [34.3 ohm] [32 ohm] [30 ohm] [28.2 ohm]

**DRAM Controller Configuration*****DRAM Power Options******Power Down Enable [Auto]***

This item allows you to enable or disable power down mode.  
 Configuration options: [Disabled] [Enabled] [Auto]

***SubUrgRefLowerBound [4]***

Specifies the stored refresh limit required to enter sub-urgent refresh mode.  
 Constraint: SubUrgRefLowerBound <= UrgRefLimit. Valid value: 6~1

***UrgRefLimit [6]***

Specifies the stored refresh limit required to enter urgent refresh mode.  
 Constraint: SubUrgRefLowerBound <= UrgRefLimit. Valid value: 6~1

***DRAM Maximum Activate Count [Auto]***

Override DIMM SPD Byte 7 [3:0]. Maximum Activate Count (MAC). When set to [Auto] it will be based on SPD setting.  
 Configuration options: [Untested MAC] [700 K] [600 K] [500 K] [400 K] [300 K] [200 K] [Unlimited MAC] [Auto]

**DRAM Refresh Rate [7.8 usec]**

Configuration options: [7.8 usec] [3.9 usec]

**Self-Refresh Exit Staggering [Disabled]**

Tcksrx += (Trfc/n \* (UMC\_Number % 4)), here n = 3 or 4.

Configuration options: [Disabled] [Trfc / 3] [Trfc / 4]

**Cmd2T**

Select between 1T and 2T mode on ADDR/CMD.

Configuration options: [Auto] [1T] [2T]

**Gear Down Mode**

Configuration options: [Auto] [Disabled] [Enabled]

**CAD Bus Configuration**

**CAD Bus Timing User Controls [Auto]**

This item allows you to set the CAD bus signals to Auto or Manual.

Configuration options: [Auto] [Manual]



---

The following items appear only when you set **CAD Bus Timing User Controls** to **[Manual]**.

---

**AddrCmdSetup [0]**

This item allows you to setup time on CAD bus signals.

Configuration options: [0] – [39]

**CsOdtSetup [0]**

This item allows you to setup time on CAD bus signals.

Configuration options: [0] – [39]

**CkeSetup [0]**

This item allows you to setup time on CAD bus signals.

Configuration options: [0] – [39]

**CAD Bus Drive Strength User Controls [Auto]**

This item allows you to set the CAD bus signals to Auto or Manual.

Configuration options: [Auto] [Manual]



---

The following items appear only when you set **CAD Bus Drive Strength User Controls** to **[Manual]**.

---

**ClkDrvStren [Auto]**

Configuration options: [Auto] [120.0 Ohm] [60.0 Ohm] [40.0 Ohm] [30.0 Ohm] [24.0 Ohm] [20.0 Ohm]

**AddrCmdDrvStren [Auto]**

Configuration options: [Auto] [120.0 Ohm] [60.0 Ohm] [40.0 Ohm] [30.0 Ohm] [24.0 Ohm] [20.0 Ohm]

**CsOdtDrvStren [Auto]**

Configuration options: [Auto] [120.0 Ohm] [60.0 Ohm] [40.0 Ohm] [30.0 Ohm] [24.0 Ohm] [20.0 Ohm]

**CkeDrvStren [Auto]**

Configuration options: [Auto] [120.0 Ohm] [60.0 Ohm] [40.0 Ohm] [30.0 Ohm] [24.0 Ohm] [20.0 Ohm]

## Data Bus Configuration

### **Data Bus Configuration User Controls [Auto]**

This item allows you to specify the mode for drive strength.

Configuration options: [Auto] [Manual]



---

The following items appear only when you set **Data Bus Configuration User Controls** to **[Manual]**.

---

### **RttNom [Auto]**

Configuration options: [Rtt\_Nom Disable] [RZQ/4] [RZQ/2] [RZQ/6] [RZQ/1] [RZQ/5] [RZQ/3] [RZQ/7] [Auto]

### **RttWr [Auto]**

Configuration options: [Dynamic ODT Off] [RZQ/2] [RZQ/1] [Hi-Z] [RZQ/3] [Auto]

### **RttPark [Auto]**

Configuration options: [Rtt\_PARK Disable] [RZQ/4] [RZQ/2] [RZQ/6] [RZQ/1] [RZQ/5] [RZQ/3] [RZQ/7] [Auto]

## Common RAS

### **Data Poisoning [Auto]**

Configuration options: [Enabled] [Disabled] [Auto]

### **DRAM Post Package Repair [Disable]**

This item allows you to enable or disable DRAM POST Package Repair.

Configuration options: [Enable] [Disable]

### **RCD Parity [Auto]**

Configuration options: [Enabled] [Disabled] [Auto]

### **DRAM Address Command Parity Retry [Auto]**

Configuration options: [Enabled] [Disabled] [Auto]



---

The following item appears only when you set **DRAM Address Command Parity Retry** to **[Enabled]**.

---

### **Max Parity Error Replay [8]**

The values in hex, 1, 2, or 3 is invalid.

Configuration options: [0] – [39]

### **Write CRC Enable [Auto]**

Configuration options: [Enabled] [Disabled] [Auto]

### **DRAM Write CRC Enable and Retry Limit [Auto]**

Configuration options: [Enabled] [Disabled] [Auto]



---

The following item appears only when you set **DRAM Write CRC Enable and Retry Limit** to **[Enabled]**.

---

### **Max Write CRC Error Replay [8]**

The values in hex, 1, 2, or 3 is invalid.

Configuration options: [0] – [39]

### **Disable Memory Error Injection [True]**

Configuration options: [False] [True]

### ***ECC Configuration***

#### ***DRAM ECC Symbol Size [Auto]***

Configuration options: [x4] [x8] [x16] [Auto]

#### ***DRAM ECC Enable [Auto]***

This option allows you to enable or disable DRAM ECC. Auto will set ECC to enable.

Configuration options: [Disabled] [Enabled] [Auto]

#### ***DRAM ECC Enable [Auto]***

This option allows you to enable or disable DRAM UECC Retry.

Configuration options: [Disabled] [Enabled] [Auto]

## **Security**

#### ***TSME [Auto]***

Configuration options: [Disabled] [Enabled] [Auto]

#### ***Data Scramble [Auto]***

Configuration options: [Disabled] [Enabled] [Auto]

## **DRAM Memory Mapping**

### **Chipselect Interleaving [Auto]**

This item allows you to set interleave memory blocks across the DRAM chip selects for node 0.

Configuration options: [Disabled] [Auto]

### **BankGroupSwap [Auto]**

Configuration options: [Enabled] [Disabled] [Auto]

### **BankGroupSwapAlt [Auto]**

Configuration options: [Enabled] [Disabled] [Auto]

### **Address Hash Bank [Auto]**

This item allows you to enable or disable bank address hashing.

Configuration options: [Enabled] [Disabled] [Auto]

### **Address Hash CS [Auto]**

This item allows you to enable or disable CS address hashing.

Configuration options: [Enabled] [Disabled] [Auto]

### **Address Hash RM [Auto]**

This item allows you to enable or disable RM address hashing.

Configuration options: [Enabled] [Disabled] [Auto]

### **SPD Read Optimization [Auto]**

This item allows you to enable or disable SPD Read Optimization, if set to **[Enabled]**, SPD reads are skipped for Reserved fields and most of upper 256 Bytes. If set to **[Disabled]**, read all 512 SPD Bytes.

Configuration options: [Enabled] [Disabled] [Auto]

## Memory MBIST

### **MBIST Enable [Disabled]**

This item allows you to enable or disable Memory MBIST.  
Configuration options: [Enabled] [Disabled]



---

The following items appear only when **MBIST Enable** is set to **[Enabled]**.

---

### **MBIST Test Mode [Auto]**

This item allows you to select the MBIST Test Mode - Interface Mode (Tests Single and Multiple CS transactions and Basic Connectivity) or Data Eye Mode (Measures Voltage vs. Timing).

Configuration options: [Interface Mode] [Data Eye Mode] [Both] [Auto]

### **MBIST Aggressors [Auto]**

This item allows you to enable or disable Memory Aggressor test.

Configuration options: [Enabled] [Disabled] [Auto]

### **MBIST Per Bit Slave Die Reporting [Auto]**

Reports 2D Data Eye Results in ABL Log for each DQ, Chipselect, and Channel.

Configuration options: [Enabled] [Disabled] [Auto]

### **Data Eye**

#### ***Pattern Select [PRBS]***

Configuration options: [PRBS] [SS0] [Both]

#### ***Pattern Length [3]***

This token helps to determine the pattern length. The possible options are N=3...12.

Configuration options: [3] – [9]

#### ***Aggressor Channel [1 Aggressor Channel]***

This helps read the aggressors channels. If set to **[Enabled]**, you can read from one or more than one aggressor channel. The default is set to **[Disabled]**.

Configuration options: [Disabled] [1 Aggressor Channel] [3 Aggressor Channels] [7 Aggressor Channels]

#### ***Aggressor Static Lane Control [Disabled]***

Configuration options: [Disabled] [Enabled]



---

The following items appear only when **Aggressor Static Lane Control** is set to **[Enabled]**.

---

#### ***Aggressor Static Lane Select Upper 32 bits [0]***

Static Lane Select for Upper 32 bits. The bit mask represents the bits to be read.

Configuration options: [0] – [99999999]

#### ***Aggressor Static Lane Select Lower 32 bits [0]***

Static Lane Select for Lower 32 bits. The bit mask represents the bits to be read.

Configuration options: [0] – [99999999]



**Aggressor Static Lane Select ECC [0]**

Static Lane Select for ECC Lanes. The bit mask represents the bits to be read.

Configuration options: [0] – [9]

**Aggressor Static Lane Value [0]**

Configuration options: [0] – [9]

**Target Static Lane Control [Disabled]**

Configuration options: [Disabled] [Enabled]

---

The following items appear only when **Target Static Lane Control** is set to **[Enabled]**.

---

**Target Static Lane Select Upper 32 bits [0]**

Static Lane Select for Upper 32 bits. The bit mask represents the bits to be read.

Configuration options: [0] – [999999999]

**Target Static Lane Select Lower 32 bits [0]**

Static Lane Select for Lower 32 bits. The bit mask represents the bits to be read.

Configuration options: [0] – [999999999]

**Target Static Lane Select ECC [0]**

Static Lane Select for ECC Lanes. The bit mask represents the bits to be read.

Configuration options: [0] – [9]

**Target Static Lane Value [0]**

Configuration options: [0] – [9]

**Data Eye Type [Worst Case Margin Only]**

This option determines which results are expected to be captured for Data Eye. Supported options are 1D Voltage Sweep, 1D Timing Sweep, 2D Full Data Eye and Worst Case Margin only.

Configuration options: [1D Voltage Sweep] [1D Timing Sweep] [2D Full Data Eye]

**Worst Case Margin Granularity [Per Chip Select]**

Configuration options: [Per Chip Select] [Per Nibble]

**Read Voltage Sweep Step Size [2]**

This option determines the step size for Read Data Eye voltage sweep.

Configuration options: [1] [2] [4]

**Read Timing Sweep Step Size [1]**

This option supports step size for Read Data Eye.

Configuration options: [1] [2] [4]

**Write Voltage Sweep Step Size [2]**

This option determines the step size for write Data Eye voltage sweep.

Configuration options: [1] [2] [4]

**Write Timing Sweep Step Size [1]**

This option supports step size for write Data Eye.

Configuration options: [1] [2] [4]

## 5.11.4 NBIO Common Options

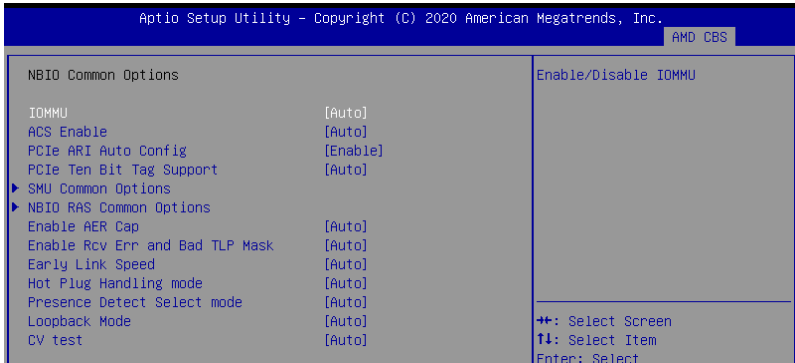

### IOMMU [Auto]

This item allows you to enable or disable IOMMU.  
Configuration options: [Disabled] [Enabled] [Auto]

### ACS Enable [Auto]

AER must be enabled for ACS enable to work.  
Configuration options: [Disable] [Enable] [Auto]

### PCIe ARI Auto Config [Enable]

Support PCIe ARI Auto Detect Rule.  
Configuration options: [Disable] [Enable]



The following item appears only when **PCIe ARI Auto Config** is set to **[Disable]**.

### PCIe ARI Support [Auto]

This item enables Alternative Routing-ID Interpretation.  
Configuration options: [Disable] [Enable] [Auto]

### PCIe Ten Bit Tag Support [Auto]

This item enables PCIe ten bit tags for supported devices. [Auto] = [Disabled].  
Configuration options: [Disable] [Enable] [Auto]

### SMU Common Options

#### Determinism Control [Auto]

- [Auto] Use the fused Determinism.
- [Manual] User can set customized Determinism.



The following item appears only when **Determinism Control** is set to **[Manual]**.

#### Determinism Slider [Auto]

Configuration options: [Auto] [Power] [Performance]

### **cTDP Control [Manual]**

[Auto] Use the fused TDP.

[Manual] User can set customized TDP.



---

The following item appears only when **cTDP Control** is set to **[Manual]**.

---

### **cTDP [240]**

This item allows you to customize cTDP.

### **Power Package Limit Control [Manual]**

[Auto] Use the fused PPT.

[Manual] User can set customized PPT.



---

The following item appears only when **Power Package Limit Control** is set to **[Manual]**.

---

### **Power Package Limit [240]**

This item allows you to customize PPT.

### **APBDIS [Auto]**

[0] Not APBDIS (mission mode)

[1] APBDIS

[Auto] Auto

### **DF Cstates [Auto]**

Configuration options: [Disabled] [Enabled] [Auto]

### **CPPC [Auto]**

Configuration options: [Disabled] [Enabled] [Auto]

### **HSMP Support [Auto]**

This option allows you to enable or disable HSMP support.

Configuration options: [Disabled] [Enabled] [Auto]

### **Diagnostic Mode [Auto]**

This option allows you to enable or disable Diag mode.

Configuration options: [Disabled] [Enabled] [Auto]

### **DLWM Support [Auto]**

This option allows you to enable or disable DLWM support.

Configuration options: [Disabled] [Enabled] [Auto]

### **Boost FmaxEn [Auto]**

[Auto] Use the default Fmax.

[Manual] User can set the boost Fmax.



---

The following item appears only when **Boost FmaxEn** is set to **[Manual]**.

---

### **Power Package Limit [0]**

This item allows you to specify the boost Fmax frequency limit to apply to all cores (MHz).

## **NBUI RAS Common Options**

### **NBIO RAS Global Control [Auto]**

Configuration options: [Auto] [Manual]

### **NBIO RAS Control [Auto]**

Configuration options: [Disabled] [MCA] [Legacy] [Auto]

### **Egress Poison Severity High [30011]**

Each bit set to 1 enables HIGH severity on the associated IOHC egress port. A bit of 0 indicates LOW severity.

### **Egress Poison Severity Low [4]**

Each bit set to 1 enables HIGH severity on the associated IOHC egress port. A bit of 0 indicates LOW severity.

### **NBIO SyncFlood Generation [Auto]**

This value may be used to mask SyncFlood caused by NBIO RAS options. When set to TRUE, SyncFlood from NBIO is masked. When set to FALSE, NBIO is capable of generating SyncFlood.

Configuration options: [Disabled] [Enabled] [Auto]

### **NBIO SyncFlood Reporting [Disabled]**

This value may be used to enable SyncFlood reporting to APML. When set to TRUE, SyncFlood will be reported to APML. When set to FALSE, the reporting will be disabled.

Configuration options: [Disabled] [Enabled]

### **Egress Poison Mask High [ffffcfff]**

These set the enable mask for masking of errors logged in EGRESS\_POISON\_STATUS. For each bit set to 1, errors are masked. For each bit set to 0, errors trigger response actions.

### **Egress Poison Mask Low [fffffffb]**

These set the enable mask for masking of errors logged in EGRESS\_POISON\_STATUS. For each bit set to 1, errors are masked. For each bit set to 0, errors trigger response actions.

### **Uncorrected Converted to Poison Enable Mask High [30000]**

These set the enable mask for masking of uncorrectable parity errors on internal arrays. For each bit set to 1, a system fatal error event is triggered for UCP errors on arrays associated with that egress port. For each bit set to 0, errors are masked.

### **Uncorrected Converted to Poison Enable Mask Low [4]**

These set the enable mask for masking of uncorrectable parity errors on internal arrays. For each bit set to 1, a system fatal error event is triggered for UCP errors on arrays associated with that egress port. For each bit set to 0, errors are masked.

### **System Hub Watchdog Timer [a28]**

This value specifies the timer interval of the SYSHUB Watchdog Timer in milliseconds.

### **SLink Read Response OK [Disabled]**

This value specifies whether SLINK read response errors are converted to an Okay response. When this value is set to TRUE, read response errors are converted to Okay responses with data of all FFs. When set to FALSE, read response errors are not converted.

### **SLink Read Response OK [Disabled]**

This value specifies whether SLINK read response errors are converted to an Okay response. When this value is set to TRUE, read response errors are converted to Okay responses with data of all FFs. When set to FALSE, read response errors are not converted.

Configuration options: [Disabled] [Enabled]

### **SLink Read Response Error Handling [Log Errors in MCA]**

This value specifies whether SLINK write response errors are converted to an Okay response. When this value is set to 0, write response errors will be logged in the MCA. When set to 1, write response errors will trigger an MCOMMIT error. When this value is set to 2, write response errors are converted.

Configuration options: [Enabled] [Trigger MCOMMIT Error] [Log Errors in MCA]

### **Log Poison data from SLINK [Disabled]**

This value specifies whether poison data propagated from SLINK will generate a deferred error. When this value is set to TRUE, deferred errors are enabled. When set to FALSE, errors are not generated.

Configuration options: [Disabled] [Enabled]

### **PCIe Aer Reporting Mechanism [Auto]**

This value selects the method of reporting AER errors from PCI Express. A value of 0 indicates that the hardware will report the error through MCA. A value of 1 allows OS First handling of the errors through generation of a system control interrupt (SCI). A value of 2 allows Firmware First handling of the errors through generation of a system control interrupt (SCI).

Configuration options: [Firmware First] [OS First] [MCA] [Auto]

### **Edge Control [Disabled]**

Configuration options: [Disabled] [Enabled] [Auto]

### **NBIO Poison Consumption [Auto]**

Configuration options: [Disabled] [Enabled] [Auto]

### **Sync Flood on PCIe Fatal Error [Auto]**

Configuration options: [Auto] [True] [False]

### Enable AER Cap [Auto]

This item allows you to enable or disable Advanced Error Reporting Capability.  
Configuration options: [Enable] [Disabled] [Auto]

### Enable Rcv Err and Bad TLP Mask [Auto]

This item allows you to enable or disable Masking of Receiver Error and Bad TLP at Gen4 x2.  
Configuration options: [Enable] [Disabled] [Auto]

### Early Link Speed [Auto]

This item allows you to set Early Link Speed.  
Configuration options: [Auto] [Gen1] [Gen2]

### Hot Plug Handling mode [Auto]

This item allows you to control the Hot Plug Handling mode.  
Configuration options: [A0 Mode] [OS First (No Error Handling)] [OS First (Error Handling - Not Implemented)] [Firmware First (Not Implemented)] [Auto]

### Presence Detect Select mode [Auto]

This item allows you to control the Presence Detect Select mode.  
Configuration options: [OR] [AND] [Auto]

### Loopback Mode [Auto]

This item allows you to enable or disable PCIe Loopback Mode.  
Configuration options: [Auto] [Disabled] [Enabled]

### CV test [Auto]

Set this to [Enabled] to support running PCIECV tool. Selecting [Auto] will preserve h/w defaults.  
Configuration options: [Auto] [Disabled] [Enabled]

## 5.11.5 NTB Common Options

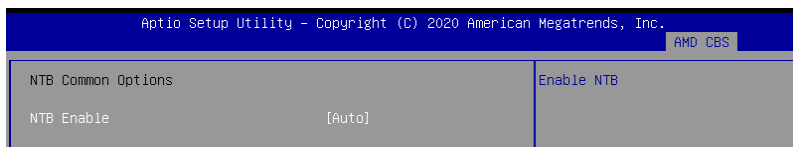

### NTB Enable [Auto]

This item allows you to enable or disable NTB.  
Configuration options: [Auto] [Enable]



The following item appears only when you set **NTB Enable** to [Enable].

### NTB Location [Auto]

Configuration options: [Auto] [Socket0-Die0] [Socket0-Die1] [Socket0-Die2] [Socket0-Die3] [Socket1-Die0] [Socket1-Die1] [Socket1-Die2] [Socket1-Die3]

### NTB active on PCIeCore [Auto]

Configuration options: [Auto] [Core0] [Core1]

### NTB Mode [Auto]

This item allows you to select the NTB Mode (Core 0, Port 0)

Configuration options: [NTB Disabled] [NTB Primary] [NTB Secondary] [NTB Random] [Auto]

### Link Speed [Auto]

This item allows you to select the Link Speed for NTB Mode (Core 0, Port 0).

Configuration options: [Max Speed] [Gen 1] [Gen 2] [Gen 3] [Auto] [Gen 4]

## 5.12 Event Logs menu

The Event Logs menu items allow you to change the event log settings and view the system event logs.

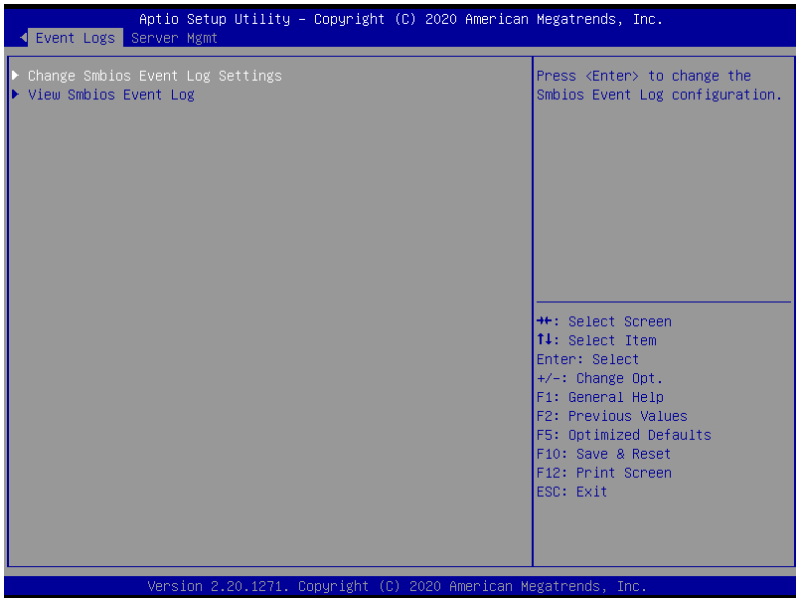

### 5.12.1 Change Smbios Event Log Settings

Press <Enter> to change the Smbios Event Log configuration.



All values changed here do not take effect until computer is restarted.

## Enabling/Disabling Options

### Smbios Event Log [Enabled]

Change this to enable or disable all features of Smbios Event Logging during boot.  
Configuration options: [Disabled] [Enabled]



---

The following items appear only when **Smbios Event Log** is set to **[Enabled]**.

---

### Erasing Settings

#### Erase Event Log [No]

Choose options for erasing Smbios Event Log. Erasing is done prior to any logging activation during reset.

Configuration options: [No] [Yes, Next reset] [Yes, Every reset]

### Smbios Event Log Standard Settings

#### Log System Boot Event [Disabled]

This option allows you to enable or disable logging System boot event.

Configuration options: [Disabled] [Enabled]

#### MECI [1]

The Multiple Event Count Increment is the occurrences of a duplicate event that must pass before the multiple-event counter of log entry is updated. The values range from 1 to 255.

#### METW [60]

The Multiple Event Time Window is the number of minutes which must pass between duplicate log entries which utilize a multiple-event counter. The values range from 0 to 99 minutes.

### Custom Options

#### Log EFI Status Code [Enabled]

This option allows you to enable or disable logging of the EFI Status Codes.

Configuration options: [Disabled] [Enabled]



---

The following item appears only when **Log EFI Status Code** is set to **[Enabled]**.

---

#### Convert EFI Status Codes to Standard Smbios Type [Disabled]

This option allows you to enable or disable converting of EFI Status Codes to Standard Smbios Type (Not all may be translated).

Configuration options: [Disabled] [Enabled]

## 5.12.2 View Smbios Event Log

Press <Enter> to view all smbios event logs.

## 5.13 Server Mgmt menu

The Server Management menu displays the server management status and allows you to change the settings.

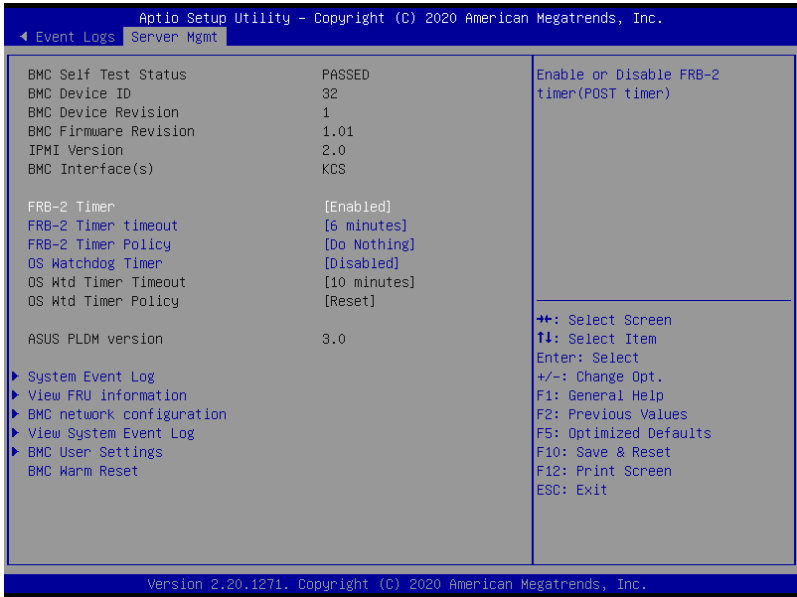

### FRB-2 Timer [Enabled]

Allows you to enable or disable FRB-2 timer (POST timer).

Configuration options: [Disabled] [Enabled]



The following items appear only when **FRB-2 Timer** is set to **[Enabled]**.

### FRB-2 Timer timeout [6 minutes]

Allows you to select the FRB-2 Timer Expiration value.

Configuration options: [3 minutes] [4 minutes] [5 minutes] [6 minutes]

### FRB-2 Timer Policy [Do Nothing]

Allows you to select the how the system should respond in FRB-2 Timer expires.

Configuration options: [Do Nothing] [Reset] [Power Down] [Power Cycle]

### OS Watchdog Timer [Disabled]

This item allows you to start a BIOS timer which can only be shut off by Intel Management Software after the OS loads.

Configuration options: [Disabled] [Enabled]



---

The following items are configurable only when the **OS Watchdog Timer** is set to **[Enabled]**.

---

### **OS Wtd Timer Timeout [10 minutes]**

Allows you to configure the length for the OS Boot Watchdog Timer.  
Configuration options: [5 minutes] [10 minutes] [15 minutes] [20 minutes]

### **OS Wtd Timer Policy [Reset]**

This item allows you to configure how the system should respond if the OS Boot Watch Timer expires.  
Configuration options: [Do Nothing] [Reset] [Power Down]

## **System Event Log**

Allows you to change the SEL event log configuration.

### **Erase SEL [No]**

Allows you to choose options for erasing SEL.  
Configuration options: [No] [Yes, On next reset] [Yes, On every reset]



---

All values changed here do not take effect until computer is restarted.

---

## **View FRU Information**

Press <Enter> to view FRU information.



---

No FRU information for fields indicate information needs to be filled by O.E.M.

---

## **BMC network configuration**

The sub-items in this configuration allow you to configure the BMC network parameters.

### **Configure IPV4 support**

### **DM\_LAN1/Shared LAN**

### **Configuration Address source [Previous State]**

This item allows you to configure LAN channel parameters statically or dynamically (by BIOS or BMC). **[Previous State]** option will not modify any BMC network parameters during BIOS phase.  
Configuration options: [Previous State] [Static] [DynamicBmcDhcp]



---

The following items are available only when **Configuration Address source** is set to **[Static]**.

---

### **Station IP address**

Allows you to set the station IP address.

### **Subnet mask**

Allows you to set the subnet mask. We recommend that you use the same Subnet Mask you have specified on the operating system network for the used network card.

**Router IP Address**

Allows you to set the router IP address.

**Router MAC Address**

Allows you to set the router MAC address.**Shared LAN**

**Configure IPV6 support****DM\_LAN1/Shared LAN****IPV6 Support [Enabled]**

Allows you to enable or disable LAN1 IPV6 Support.  
Configuration options: [Disabled] [Enabled]



---

The following item appears only when **IPV6 Support** is set to **[Enabled]**.

---

**Configuration Address source [Previous State]**

This item allows you to configure LAN channel parameters statistically or dynamically (by BIOS or BMC). **[Previous State]** option will not modify any BMC network parameters during BIOS phase.  
Configuration options: [Previous State] [Static] [DynamicBmcDhcp]



---

The following items are available only when **Configuration Address source** is set to **[Static]**.

---

**Station IPV6 address**

Allows you to set the station IPV6 address.

**Prefix Length**

Allows you to set the prefix length (maximum of Prefix Length is 128).

**IPV6 Router1 IP Address**

Allows you to set the IPV6 Router1 IP address.

**View System Event Log**

This item allows you to view the system event log records.

**BMC User Settings**

The sub-items in this configuration allow you to add, delete, or change BMC user settings.

**BMC Warm Reset**

Press <Enter> to perform a BMC Warm Reset.

# Driver Installation

# 6

This chapter provides the instructions for installing the necessary drivers for different system components in the Windows® Operating System.

## 6.1 Running the Support DVD

The support DVD that is bundled with your motherboard contains drivers, management applications, and utilities that you can install to maximize the features of your motherboard.



- The contents of the support DVD are subject to change at any time without notice. Visit the ASUS website ([www.asus.com](http://www.asus.com)) for the latest updates on software and utilities.
- The support DVD is supported on Windows® Server 2016 and Windows® Server 2019.

The main screen of the Support DVD contains the following tabs:

1. **Drivers** - Shows the available device drivers that the system detects.
2. **Utilities** - Displays the software applications and utilities that the motherboard supports.
3. **Manual** - Provides the link to the user guide(s).



You need an Internet browser installed in your OS to view the User Guide.

4. **Contact** - Displays the ASUS contact information, e-mail addresses, and useful links if you need more information or technical support for your motherboard.

# Appendix

This appendix includes additional information that you may refer to when configuring the motherboard.



## Notices

### Federal Communications Commission Statement

This device complies with Part 15 of the FCC Rules. Operation is subject to the following two conditions:

- This device may not cause harmful interference.
- This device must accept any interference received including interference that may cause undesired operation.

This equipment has been tested and found to comply with the limits for a Class A digital device, pursuant to part 15 of the FCC Rules. These limits are designed to provide reasonable protection against harmful interference when the equipment is operated in a commercial environment. This equipment generates, uses, and can radiate radio frequency energy and, if not installed and used in accordance with the instruction manual, may cause harmful interference to radio communications. Operation of this equipment in a residential area is likely to cause harmful interference in which case the user will be required to correct the interference at his own expense.



---

The use of shielded cables for connection of the monitor to the graphics card is required to assure compliance with FCC regulations. Changes or modifications to this unit not expressly approved by the party responsible for compliance could void the user's authority to operate this equipment.

---

### Compliance Statement of Innovation, Science and Economic Development Canada (ISED)

This device complies with Innovation, Science and Economic Development Canada licence exempt RSS standard(s). Operation is subject to the following two conditions: (1) this device may not cause interference, and (2) this device must accept any interference, including interference that may cause undesired operation of the device.

CAN ICES-003(A)/NMB-003(A)

### Déclaration de conformité de Innovation, Sciences et Développement économique Canada (ISED)

Le présent appareil est conforme aux CNR d'Innovation, Sciences et Développement économique Canada applicables aux appareils radio exempts de licence. L'exploitation est autorisée aux deux conditions suivantes : (1) l'appareil ne doit pas produire de brouillage, et (2) l'utilisateur de l'appareil doit accepter tout brouillage radioélectrique subi, même si le brouillage est susceptible d'en compromettre le fonctionnement.

CAN ICES-003(A)/NMB-003(A)

## Australia statement notice

From 1 January 2012 updated warranties apply to all ASUS products, consistent with the Australian Consumer Law. For the latest product warranty details please visit <https://www.asus.com/support/>. Our goods come with guarantees that cannot be excluded under the Australian Consumer Law. You are entitled to a replacement or refund for a major failure and compensation for any other reasonably foreseeable loss or damage. You are also entitled to have the goods repaired or replaced if the goods fail to be of acceptable quality and the failure does not amount to a major failure.

If you require assistance please call ASUS Customer Service 1300 2787 88 or visit us at <https://www.asus.com/support/>.



---

DO NOT throw the motherboard in municipal waste. This product has been designed to enable proper reuse of parts and recycling. This symbol of the crossed out wheeled bin indicates that the product (electrical and electronic equipment) should not be placed in municipal waste. Check local regulations for disposal of electronic products.

---



---

DO NOT throw the mercury-containing button cell battery in municipal waste. This symbol of the crossed out wheeled bin indicates that the battery should not be placed in municipal waste.

---

## Japan statement notice

This product cannot be directly connected to the Internet (including public wireless LAN) of a telecom carrier (mobile network companies, landline network companies, Internet providers, etc.). When connecting this product to the Internet, be sure to connect it through a router or switch.

## **Declaration of compliance for product environmental regulation**

ASUS follows the green design concept to design and manufacture our products, and makes sure that each stage of the product life cycle of ASUS product is in line with global environmental regulations. In addition, ASUS disclose the relevant information based on regulation requirements.

Please refer to <http://csr.asus.com/Compliance.htm> for information disclosure based on regulation requirements ASUS is complied with:

### **EU REACH and Article 33**

Complying with the REACH (Registration, Evaluation, Authorization, and Restriction of Chemicals) regulatory framework, we publish the chemical substances in our products at ASUS REACH website at <http://csr.asus.com/english/REACH.htm>.

### **EU RoHS**

This product complies with the EU RoHS Directive. For more details, see <http://csr.asus.com/english/article.aspx?id=35>

### **Japan JIS-C-0950 Material Declarations**

Information on Japan RoHS (JIS-C-0950) chemical disclosures is available on <http://csr.asus.com/english/article.aspx?id=19>

## India RoHS

This product complies with the “India E-Waste (Management) Rules, 2016” and prohibits use of lead, mercury, hexavalent chromium, polybrominated biphenyls (PBBs) and polybrominated diphenyl ethers (PBDEs) in concentrations exceeding 0.1% by weight in homogenous materials and 0.01% by weight in homogenous materials for cadmium, except for the exemptions listed in Schedule II of the Rule.

## Vietnam RoHS

ASUS products sold in Vietnam, on or after September 23, 2011, meet the requirements of the Vietnam Circular 30/2011/TT-BCT.

Các sản phẩm ASUS bán tại Việt Nam, vào ngày 23 tháng 9 năm 2011 trở về sau, đều phải đáp ứng các yêu cầu của Thông tư 30/2011/TT-BCT của Việt Nam.

## Turkey RoHS

AEEE Yönetmeliğine Uygundur

## ASUS Recycling/Takeback Services

ASUS recycling and takeback programs come from our commitment to the highest standards for protecting our environment. We believe in providing solutions for you to be able to responsibly recycle our products, batteries, other components as well as the packaging materials. Please go to <http://csr.asus.com/english/Takeback.htm> for detailed recycling information in different regions.

## Ecodesign Directive

European Union announced a framework for the setting of ecodesign requirements for energy-related products (2009/125/EC). Specific Implementing Measures are aimed at improving environmental performance of specific products or across multiple product types. ASUS provides product information on the CSR website. The further information could be found at <https://csr.asus.com/english/article.aspx?id=1555>.

## Service and Support

Visit our multi-language website at <https://www.asus.com/support/>

