

```
HyperTerminal
File Edit View Call Transfer Help
SISPM1040-3248-L# show version
MAC Address      : 00-c0-f2-49-39-b4
Previous Restart : Cold

System Contact  :
System Name     : SISPM1040-3248-L
System Location :
System Time     : 2016-01-01T02:29:56+00:00
System Uptime   : 02:30:20

Bootloader
-----
Active Image
-----
Image           : linux (primary)
Version         :
Date           :
Backup Image
-----
Image           :
Version         :
Date           :
SISPM1040-3248-L#
```

SISPM1040-3xxx-L

Managed Hardened Gigabit Ethernet PoE+ Rack Mountable Switches

SISPM1040-3166-L Managed Hardened Gigabit Ethernet PoE+ Switch, (16) 10/100/1000Base-T PoE+ ports + (4) 100/1000Base-X SFP/RJ-45 Combo + (2) 1G/10G SFP+

SISPM1040-3248-L Managed Hardened Gigabit Ethernet PoE+ Switch, (24) 10/100/1000Base-T PoE+ ports + (4) 100/1000Base-X SFP/RJ-45 Combo + (4) 1G/10G SFP+

CLI Reference

Intellectual Property

© 2022-2024 Lantronix, Inc. All rights reserved. No part of the contents of this publication may be transmitted or reproduced in any form or by any means without the written permission of Lantronix.

Lantronix is a registered trademark of Lantronix, Inc. in the United States and other countries.

Patented: <https://www.lantronix.com/legal/patents/>; additional patents pending.

Warranty

For details on the Lantronix warranty policy, go to <http://www.lantronix.com/support/warranty>.

Contacts

Lantronix Corporate Headquarters

48 Discovery, Suite 250

Irvine, CA 92618, USA

Toll Free: 800-526-8766

Phone: 949-453-3990

Fax: 949-453-3995

Technical Support

Online: <https://www.lantronix.com/technical-support/>

Sales Offices

For a current list of our domestic and international sales offices, go to www.lantronix.com/about/contact.

Disclaimer

All information contained herein is provided "AS IS." Lantronix undertakes no obligation to update the information in this publication. Lantronix does not make, and specifically disclaims, all warranties of any kind (express, implied or otherwise) regarding title, non-infringement, fitness, quality, accuracy, completeness, usefulness, suitability or performance of the information provided herein. Lantronix shall have no liability whatsoever to any user for any damages, losses and causes of action (whether in contract or in tort or otherwise) in connection with the user's access or usage of any of the information or content contained herein. The information and specifications contained in this document are subject to change without notice.

Revision History

Date	Rev.	Comments
3/15/21	F	FW v8.50.0018: Include one step FW version update. Fix API "get fw upgrade status". Fix API response if changing IP address. Fix Backup Config issue. Fix LLDP PMD Auto-Negotiation Advertised Capability field. Modify "Always On PoE" to be enabled and displayed on Web UI after upgrading to FW v8.50.0018 or above. Fixes: MRP_Ring state "unknown" issue when cable removed. Add "PoE Firmware Version" data in API get_poe_config. Provide "profile selection" when using API get_poe_config to get PoE schedule.
8/20/21	G	FW v8.50.0032: add Memory Usage info on the system information; fix API Save config problem. Fix change PoE mode from Force mode and MIB PoE Config Port PoE Mode issues. Add new API commands and fix existing API commands. Fix traceroute IPv6 in the Web UI.
8/23/24	H	<p>FW v8.50.0149: Add Percepixon and LPM support.</p> <ul style="list-style-type: none"> ◆ Add ability to reboot the switch when DI input goes High. ◆ Add DHCP per VLAN support. ◆ Initial Lantronix rebrand. ◆ Change SNMP mode default and Auth Method default. ◆ Fix CLI boot message and "ip link-local interface 2" CLI command. ◆ Add STP 'Hello Time' parameter. ◆ Delete Command Summary. ◆ Update SSH. ◆ Update self-signed certificates and update to TLSv1.2 ciphers. ◆ Fix PoE Firmware version and PoE power issues. ◆ Allow to delete VLAN1 on web GUI. ◆ Add a note on using SSH/Telnet. <p>See the Release Notes for details.</p>

Contents

Chapter 1	Introduction	6
	Key Features	6
	About This Manual	6
	Related Manuals	6
Chapter 2	CLI Management	7
	Connect to the Network.....	7
	Login to the CLI.....	7
	CLI Command Modes	7
	Change Between Command Modes	8
	Command Line Controls	8
	Exec Mode Commands	9
Chapter 3	CableDiag Commands	12
Chapter 4	Clear Commands	13
Chapter 5	Config Mode Commands	22
Chapter 6	Interface Config Mode Commands	124
Chapter 7	Copy Commands	163
Chapter 8	Delete Commands	165
Chapter 9	Dir Commands	166
Chapter 10	Disable Commands	167
Chapter 11	Do Commands	168
Chapter 12	Dot1x Commands	169
Chapter 13	Enable Commands	172
Chapter 14	ERPS Commands	173
Chapter 15	Firmware Commands	175
Chapter 16	IP Commands	176
Chapter 17	Iperf Commands	179
Chapter 18	Iperf3 Commands	180
Chapter 19	IPv6 Commands	181
Chapter 20	Link OAM Commands	183
Chapter 21	More Commands	185
Chapter 22	Ping Commands	186
Chapter 23	PTP Commands	187
Chapter 24	Reload Commands	192
Chapter 25	Send Commands	193
Chapter 26	Show Commands	194

Chapter 27 Terminal Commands	242
Chapter 28 Traceroute Commands	243
Chapter 29 DHCP per Port	244
Appendix A – MRP Configuration	247
MRP Pre-Requisites and Application Examples	247
MRP Description	247
MRP Operation.....	247
MRP Sample Setup.....	248
MRP Pre-Requisites (General)	248
MRP Configuration (CLI Commands)	249

Chapter 1 Introduction

The SISPM1040-3xxx-L switches are next-generation rack mount industrial grade Ethernet switches offering powerful L2 and basic L3 features with advanced functionality and usability. In addition to the extensive management features, the SISPM1040-3xxx-L also provide Carrier Ethernet features such as OAM, CFM, ERPS, EPS, and PTPv2 which makes it suitable for industrial and Carrier Ethernet applications.

The **SISPM1040-3248-L** has 24 (10M/100M/1G) RJ45/PoE+ (support 802.3at/af, and total up to 250W/370W) ports, 4 GbE SFP ports, 2/4 GbE/10G SFP+ ports and one RJ45 Console port.

The **SISPM1040-3166-L** has (16) 10/100/1000Base-T PoE+ ports, (4) 100/1000Base-X SFP/RJ-45 Combo and (2) 1G/10G SFP+ ports.

Key Features

- DMS (Device Management System) built in
- Carrier Ethernet features for easier manageability, security and QoS
- IEEE 1588v2 PTP (TC)
- IEEE 802.3ah OAM and IEEE 802.1ag CFM
- ITU-T G.8031 Ethernet Linear Protection Switching (EPS)
- ITU-T G.8032 Ethernet Ring Protection Switching (ERPS)
- DHCP Server
- IPv4/IPv6 L3 Static route
- SCP (Secure Copy Protocol)
- Shared and Independent VLAN Learning (SVL and IVL)
- PoE (complies w/ IEEE 802.3at & af) PoE Scheduling, Power Delay, Auto Power Reset, Always on PoE
- MRP Ring and Rapid Ring
- PercepXion and LPM support

About This Manual

This manual describes how to operate the SISPM1040-3xxx-L switch CLI. This manual is intended for use by network administrators who are responsible for operating and maintaining network equipment; it assumes a working knowledge of general switch functions, Internet Protocol (IP), and Telnet Protocol.

Related Manuals

A printed Quick Start Guide is shipped with each device.

For Lantronix Documentation, Firmware, Application Notes, etc. go to the [Technical Resource Center](#).

For SFP manuals see Lantronix [SFP webpage](#).

Note that this manual provides links to third party web sites for which Lantronix is not responsible.

Other related manuals are listed below.

- SISPM1040-3xxx-L Quick Start Guide, 33761
- SISPM1040-3xxx-L Install Guide, 33762
- SISPM1040-3xxx-L Web User Guide, 33763
- SISPM1040-3248-L and 3166-L API User Guide, 33831
- Release Notes (version specific)

Chapter 2 CLI Management

Connect to the Network

To connect to the network via the CLI:

1. Attach the RJ45 serial port on the switch's front panel Console port.
2. At "Com Port Properties" Menu, configure the parameters as below:

Baud rate	115200
Stop bits	1
Data bits	8
Parity	N
Flow control	none

Login to the CLI

The command line interface (CLI) is a text-based interface. Users can access the CLI through either a direct serial connection to the device or a connection tool (e.g., SSH or Telnet) session. The default IP address is 192.168.1.77. The default username and password to log into the switch are:

Username:	admin
Password:	admin

After you login successfully, the prompt will be shown as "<sys_name>#". It means you have administrator level privileges and can perform all switch functions. If not logged in as an administrator, the prompt displays as "<sys_name>>", which means you have guest privileges and can only enter a subset of the commands that the administrator can enter. Each CLI command has a specific privilege level.

Note that Telnet is not secure and can expose data to potential eavesdroppers. Consider using SSH for more secure communications. Per a Microsoft Tutorial dated 5/29/24 (<https://learn.microsoft.com/en-us/windows/terminal/tutorials/ssh>): "The latest builds of Windows 10 and Windows 11 include a built-in SSH server and client that are based on OpenSSH, a connectivity tool for remote sign-in that uses the SSH protocol. OpenSSH encrypts all traffic between client and server to eliminate eavesdropping, connection hijacking, and other attacks."

CLI Command Modes

The CLI is divided into several modes. If a user has enough privilege to run a particular command, the user has to run the command in the correct mode. To see the commands of the mode, enter a "?" after the system prompt, and then all commands will be displayed on the screen. The command modes are listed below:

Mode	Prompt	Command Function in this Mode
exec	<sys_name>#	Display current configuration, diagnostics, maintenance
config	<sys_name>(config)#	Configure features other than those below
Config-if	<sys_name>(config-interface)#	Configure ports
Config-if-vlan	<sys_name>(config-if-vlan)#	Configure static vlan

Commands reside in a specific mode and can only be run in that mode. If a user wants to run a particular command, the user must change to the appropriate mode. The command modes are organized as a tree, and users start in Exec mode. The following table explains how to change from one mode to another.

Change Between Command Modes

Mode	Enter Mode	Leave Mode
exec	--	--
config	Configure terminal	exit
config-interface	Interface <port-type> <port-type-list>	exit
config-vlan	Interface vlan <vlan_list>	exit

Command Line Controls

To navigate the command line:

To display	Press	Description
more	-	dash key
next page	Space	space bar
continue	g	g key
quit	^C	Control C
Available parameters	?	Single question mark
Syntax	??	Two question marks
Available commands in table format	Tab key	available commands in table format

Exec Mode Commands

```

SISPM1040-3248-L# ?
  CableDiag      Cable Diagnostic keyword
  clear          Clear
  configure      Enter configuration mode
  copy           Copy from source to destination
  delete         Delete one file in flash: file system
  dir            Directory of all files in flash: file system
  disable        Turn off privileged commands
  do             To run exec commands in the configuration mode
  dot1x         IEEE Standard for port-based Network Access Control
  enable        Turn on privileged commands
  erps          Ethernet Ring Protection Switching
  exit          Exit from EXEC mode
  firmware      Firmware upgrade/swap
  help          Description of the interactive help system
  ip            IPv4 commands
  iperf         network bandwidth measurement tool
  iperf3        network bandwidth measurement tool
  ipv6          IPv6 configuration commands
  link-oam      Link OAM configuration
  logout        Exit from EXEC mode
  more          Display file
  no            Delete trace hunt string
  ping          Send ICMP echo messages
  platform      Platform configuration
  ptp           Misc non persistent 1588 settings.
  reload        Reload system.
  rfc2544       RFC2544 performance tests
  send          Send a message to other tty lines
  show          Display statistics counters.
  terminal      Set terminal line parameters
  traceroute    Send IP Traceroute messages
  y1564        Y.1564 service activation tests
SISPM1040-3248-L#

```

Command: `exit`

Description: Exit from Exec mode; you must hit Enter and then log in again.

Syntax: `exit <cr>`

Parameters: None.

Example:

```

SISPM1040-3248-L# exit
Username:
Password:

```

Command: **help (?)**

Description: Description of the interactive help system. The three forms of the ? command are:

SISPM1040-3248-L# **copy?** (command no space ?) gives a command description.

SISPM1040-3248-L# **copy_?** (command space ?) lists the command parameters.

SISPM1040-3248-L# **copy??** (command no space ??) lists the command syntax.

Syntax: **help** <cr>

Parameters: None.

Example:

```
SISPM1040-3248-L# help
```

Help may be requested at any point in a command by entering a question mark '?'. If nothing matches, the help list will be empty and you must backup until entering a '?' shows the available options.

Two styles of help are provided:

1. Full help is available when you are ready to enter a command argument (e.g. 'show ?') and describes each possible argument.
2. Partial help is provided when an abbreviated argument is entered and you want to know what arguments match the input (e.g. 'show pr?'.)

```
SISPM1040-3248-L#
```

Command: **logout**

Description: Exit from EXEC mode; you must hit Enter and then log in again.

Syntax: **logout** <cr>

Parameters: None.

Example:

```
SISPM1040-3248-L# logout
```

```
Username:
```

```
Password:
```

```
SISPM1040-3248-L#
```

Command: platform

Description: Platform configuration; allow or deny use of Debug commands. **WARNING:** The use of 'debug' commands may negatively impact system behavior. Do not enable unless instructed to. (Use 'platform debug deny' to disable debug commands.)

NOTE: 'debug' command syntax, semantics and behavior are subject to change without notice.

Syntax: **platform** debug { allow | deny }

Parameters: debug Debug command setting
allow Allow debug commands
deny Deny debug commands

Example:

```
SISPM1040-3248-L# platform debug deny
```

```
SISPM1040-3248-L# platform debug allow
```

WARNING: The use of 'debug' commands may negatively impact system behavior. Do not enable unless instructed to. (Use 'platform debug deny' to disable debug commands.)

NOTE: 'debug' command syntax, semantics and behavior are subject to change without notice.

```
SISPM1040-3248-L#
```

Chapter 3 CableDiag Commands

Command: CableDiag

Description: Run the cable diagnostic and display test result.

Syntax: **CableDiag** interface GigabitEthernet <port_type_id>

Parameters: Interface Interface keyword
 GigabitEthernet 1 Gigabit Ethernet Port
 <port_type_id> Port ID in 1/1-24

Example:

```
SISPM1040-3248-L# CableDiag interface GigabitEthernet 1/1
Starting Cable Diagnostic - Please wait
Interface          Link Status      Test Result      Length
-----
GigabitEthernet 1/1  Link Down       detect error or check cable length is between 7-120
meters
SISPM1040-3248-L# CableDiag interface GigabitEthernet 1/1
Starting Cable Diagnostic - Please wait
Interface          Link Status      Test Result      Length
-----
GigabitEthernet 1/1  1G              OK               3(m)
SISPM1040-3248-L# CableDiag interface GigabitEthernet 1/24
Starting Cable Diagnostic - Please wait
Interface          Link Status      Test Result      Length
-----
GigabitEthernet 1/24  Link Down       detect error or check cable length is between 7-120
meters
SISPM1040-3248-L# CableDiag interface GigabitEthernet 1/28
% No such interface: GigabitEthernet 1/28

SISPM1040-3248-L#
```

Chapter 4 Clear Commands

Table : clear Commands

<u>Command</u>	<u>Function</u>
access	Clear Access management
access-list	Clear Access list
dot1x	Clear IEEE Standard for port-based Network Access Control
eps	Clear Ethernet Protection Switching
erps	Clear Ethernet Ring Protection Switching
evc	Clear Ethernet Virtual Connections
ip	Clear IP protocol
ipv6	Clear Ipv6 configuration commands
lacp	Clear LACP statistics
link-oam	Clear Link OAM statistics
lldp	Clear LLDP statistics
logging	Clear System logging message
mac	Clear MAC Address Table
mep	Clear Maintenance Entity Point
mvr	Clear Multicast VLAN Registration configuration
perf-mon	Clear Performance Monitor
port-security	Clear Port Security
ptp	Clear Precision Timing Protocol v2
sflow	Clear Statistics flow
spanning-tree	Clear STP Bridge
statistics	Clear statistics for one or more given interfaces
system	Clear system parameters

Command: **access**

Description: Clear Access management Statistics data.

Syntax: **clear access management statistics** <cr>

Parameters: management Access management configuration
statistics Statistics data

Example:

```
SISPM1040-3248-L# clear access management ?
      statistics      Statistics data
SISPM1040-3248-L# clear access management statistics ?
      <cr>
SISPM1040-3248-L# clear access management statistics
SISPM1040-3248-L#
```

Command: **access-list**

Description: Clear Access List ACE Statistics.

Syntax: **clear** access-list ace statisticsParameters: ace Access list entry
statistics Traffic statistics

Example:

```
SISPM1040-3248-L# clear access-list?
  Access-list  Access list
SISPM1040-3248-L# clear access-list ?
  ace  Access list entry
SISPM1040-3248-L# clear access-list ace ?
  statistics  Traffic statistics
SISPM1040-3248-L# clear access-list ace statistics ?
  <cr>
SISPM1040-3248-L# clear access-list ace statistics
SISPM1040-3248-L#
```

Command: **dot1x**

Description: Clear IEEE Standard for port-based Network Access Control statistics.

Syntax: **clear** dot1x statistics [interface (<port_type> [<v_port_type_list>])]Parameters: statistics Clears the statistics counters
interface Interface
* All switches or All ports
GigabitEthernet 1 Gigabit Ethernet Port
10GigabitEthernet 10 Gigabit Ethernet Port
<port_type_list> Port list for all port types
<port_type_list> Port list in 1/1-28
<cr>
<port_type_list> Port list in 1/1-4

Example:

```
SISPM1040-3248-L# clear dot1x statistics interface GigabitEthernet 1/4 10GigabitEthernet ?
  <port_type_list>  Port list in 1/1-4
SISPM1040-3248-L# $tics interface GigabitEthernet 1/4 10GigabitEthernet 1/2
```

Command: **eps**

Description: Clear Ethernet Protection Switching.

Syntax: **clear** eps <inst> wtrParameters: <uint> The EPS instance number.
Wtr Clear active WTR.

Example:

```
SISPM1040-3248-L# clear eps?
  Eps      Ethernet Protection Switching.
SISPM1040-3248-L# clear eps 0 wtr
SISPM1040-3248-L#
```

Messages: *Invalid EPS instance number*
Error: EPS instance is not created

Command: **erps**

Description: Clear Ethernet Ring Protection Switching statistics

Syntax: **clear** erps 1 statisticsParameters: 1~64 Zero or more ERPS group numbers
statistics Clear ERPS statistics

Example:

```
SISPM1040-3248-L# clear erps 1 statistics
SISPM1040-3248-L#
```

Command: **evc**

Description: Clear Ethernet Virtual Connections statistics.

Syntax: **clear** evc statistics { [<evc_id> | all] } [ece [<ece_id>]] [interface (<port_type> [<port_list>])] [class <cosid>] [pw <pw_num_list>]Parameters: <1-454> EVC identifier
class Select Class of Service ID
interface Interface
pw Clear EVC statistics for attached MPLS-TP Pseudo-Wires
<cr>

Example:

```
SISPM1040-3248-L# clear evc statistics 1 pw 1
SISPM1040-3248-L#
```

Command: **ip**

Description: Clear Ipv4 protocol parameters.

Syntax:

```
clear ip acd
clear ip arp
clear ip dhcp detailed statistics { server | client | snooping | relay | helper | all } [ interface ( <port_type> [
<in_port_list> ] ) ]
clear ip dhcp relay statistics
clear ip dhcp server binding <ip>
clear ip dhcp server binding type { automatic | manual | expired }
clear ip dhcp server statistics
clear ip dhcp snooping statistics [ interface ( <port_type> [ <in_port_list> ] ) ]
clear ip igmp snooping [ vlan <v_vlan_list> ] statistics
clear ip statistics
```

Parameters:

acd	Address Conflict Detection
arp	Clear ARP cache
dhcp	Dynamic Host Configuration Protocol
igmp	Internet Group Management Protocol
statistics	Traffic statistics

Example:

```
SISPM1040-3248-L# clear ip statistics
SISPM1040-3248-L# clear ip igmp snooping statistics
SISPM1040-3248-L#
```

Command: **ipv6**

Description: Clear Ipv6 configuration parameters.

Syntax:

```
clear ipv6 mld snooping [ vlan <v_vlan_list> ] statistics
clear ipv6 neighbors
clear ipv6 statistics
```

Parameters:

mld	Multicast Listener Discovery
neighbors	Ipv6 neighbors
statistics	Traffic statistics

Example:

```
SISPM1040-3248-L# clear ipv6 statistics
SISPM1040-3248-L# clear ipv6 mld snooping statistics
SISPM1040-3248-L# clear ipv6 mld snooping vlan 100 statistics
SISPM1040-3248-L#
```

Command: **lACP**

Description: Clear LACP statistics.

Syntax: clear lACP statistics

Parameters: statistics Clear all LACP statistics
<cr>

Example:

```
SISPM1040-3248-L# clear lACP statistics
SISPM1040-3248-L#
```

Command: **link-oam**

Description: Clear Link OAM statistic on a specific interface or all interfaces.

Syntax: **clear** link-oam statistics [interface (<port_type> [<plist>])]

Parameters: interface Clear Link OAM statistic on a specific interface or all interfaces.
 * All switches or All ports
 GigabitEthernet 1 Gigabit Ethernet Port
 10GigabitEthernet 10 Gigabit Ethernet Port
 <port_type_list> Port list in 1/1-28
 * All switches or All ports
 GigabitEthernet 1 Gigabit Ethernet Port
 10GigabitEthernet 10 Gigabit Ethernet Port
 <cr>

Example:

```
SISPM1040-3248-L# clear link-oam statistics interface GigabitEthernet 1/4
SISPM1040-3248-L#
```

Command: **lldp**

Description: Clear LLDP statistics.

Syntax: **clear** lldp statistics { [interface (<port_type> [<plist>])] | global }

Parameters: statistics Clears LLDP statistics.
 lldp Clears LLDP statistics.
 | Output modifiers
 global Clear global counters
 interface Interface keyword.
 <cr>

Example:

```
SISPM1040-3248-L# clear lldp statistics
SISPM1040-3248-L# clear lldp statistics interface *
SISPM1040-3248-L#
```

Command: **logging**

Description: Clear System logging messages.

Syntax: **clear** logging [info] [warning] [error] [emerg] [alert] [crit] [notice] [debug] [switch <switch_list>]

Parameters:	alert	Severity 1: Action must be taken immediately
	crit	Severity 2: Critical conditions
	debug	Severity 7: Debug-level messages
	emerg	Severity 0: System is unusable
	error	Severity 3: Error conditions
	info	Severity 6: Informational messages
	notice	Severity 5: Normal but significant condition
	warning	Severity 4: Warning conditions
	<cr>	

Example:

```
SISPM1040-3248-L# clear logging debug info
SISPM1040-3248-L# clear logging debug info notice
SISPM1040-3248-L#
```

Command: **mac**

Description: Flush MAC Address table.

Syntax: **clear** mac address-table

Parameters: None

Example:

```
SISPM1040-3248-L# clear mac address-table
SISPM1040-3248-L#
```

Command: **mep**

Description: Clear Maintenance Entity end Point.

Syntax: **clear** mep <inst> { lm [both | tx | rx] | dm | lb | tst | bfd }

Parameters:	<uint>	The MEP instance.
	Dm	Clear DM measuring information.
	Lb	Clear LB measuring information.
	Lm	Clear LM measuring information.
	Tst	Clear TST measuring information.

Example:

```
SISPM1040-3248-L# clear mep 1 dm
SISPM1040-3248-L# clear mep 1 tst
SISPM1040-3248-L#
```

Command: **mvr**

Description: Clear Multicast VLAN Registration configuration.

Syntax: **clear** mvr [vlan <v_vlan_list> | name <mvr_name>] statistics

Parameters: name MVR multicast name
 statistics Running MVR protocol counters
 vlan MVR multicast VLAN

Example:

```
SISPM1040-3248-L# clear mvr statistics
SISPM1040-3248-L# clear mvr vlan 100 statistics
SISPM1040-3248-L
```

Command: **perf-mon**

Description: Clear Performance Monitor

Syntax: **clear** perf-mon statistics [lm | dm | evc]

Parameters: dm Delay Measurement
 evc EVC
 lm Loss Measurement
 <cr>

Example:

```
SISPM1040-3166-L# clear perf-mon statistics evc
SISPM1040-3166-L# clear perf-mon statistics lm
SISPM1040-3166-L#
```

Command: **port-security**

Description: Clear port security. You can also configure a specific interface. See [Interface Config Commands](#).

Syntax: **clear** port-security sticky { All | interface (<port_type> [<plist>]) }

clear port-security dynamic [{ address <mac> [vlan <vlan_on_mac>] } | { interface (<port_type> [<plist>]) [vlan <vlan_on_interface>] } | vlan <vlan>]

Parameters: dynamic Dynamic entries
 sticky port security sticky function.
 Address Clear a specific (VLAN, MAC) tuple
 interface Port interface
 vlan Delete all MAC addresses on a given VLAN
 <cr>

Example:

```
SISPM1040-3248-L# clear port-security dynamic address 11-22-33-44-55-66
SISPM1040-3248-L# clear port-security sticky ?
  All          clear all sticky mac at all ports
  interface   Choose port
SISPM1040-3248-L# clear port-security sticky All
```

Command: **ptp**

Description: Clear PTP servo for a Precision Timing Protocol (PTP v2) clock instance.

Syntax: **clear** ptp <clockinst> servo

Parameters: <0-3>
servo
<cr>

Example:

```
SISPM1040-3248-L# clear ptp 0 servo
SISPM1040-3248-L#
```

Messages: *Clock instance 0 : does not exist*
%% Failed to set network-clock configuration.
% (MESA: Unknown error code)

Command: **sflow**

Description: Clear sflow statistics.

Syntax: **clear** sflow statistics { receiver [<receiver_index_list>] | samplers [interface [<samplers_list>] (<port_type> [<v_port_type_list>])] }

Parameters: receiver Clear statistics for receiver.
Samplers Clear statistics for samplers.
Interface Clear statistics for a specific interface or interfaces.
<cr>

Example:

```
SISPM1040-3248-L# clear sflow statistics receiver
SISPM1040-3248-L# clear sflow statistics sampler ?
    interface Clear statistics for a specific interface or interfaces.
    <cr>
SISPM1040-3248-L# clear sflow statistics sampler
SISPM1040-3248-L#
```

Command: **spanning-tree**

Description: Clear spanning tree parameters.

Syntax: **clear** spanning-tree { { statistics [interface (<port_type> [<v_port_type_list>])] } | { detected-protocols [interface (<port_type> [<v_port_type_list_1>])] } }

Parameters:

detected-protocols	Set the STP migration check
statistics	STP statistics
interface	Choose port
<cr>	
*	All switches or All ports
GigabitEthernet	1 Gigabit Ethernet Port
10GigabitEthernet	10 Gigabit Ethernet Port

Example:

```
SISPM1040-3248-L# clear spanning-tree statistics
SISPM1040-3248-L# clear spanning-tree detected-protocols
SISPM1040-3248-L#
```

Command: **statistics**

Description: Clear statistics for one or more given interfaces.

Syntax: **clear** statistics [interface] (<port_type> [<v_port_type_list>])

Parameters:

*	All switches or All ports
GigabitEthernet	1 Gigabit Ethernet Port
10GigabitEthernet	10 Gigabit Ethernet Port
interface	Interface
<port_type_list>	Port list in 1/1-28
<port_type_list>	Port list in 1/1-4

Example:

```
SISPM1040-3248-L# clear statistics interface GigabitEthernet 1/9
SISPM1040-3248-L#
```

Command: **system**

Description: Clear system LED status.

Syntax: **clear** system led status [switch <switch_list>] { fatal | software | post | ztp | stack-firmware | all }

Parameters:

all	Clear all error status of the system LED and back to normal indication
fatal	Clear fatal error status of the system LED
software	Clear generic software error status of the system LED

Example:

```
SISPM1040-3248-L# clear system led status software
SISPM1040-3248-L# clear system led status fatal
SISPM1040-3248-L# clear system led status all
SISPM1040-3248-L#
```

Chapter 5 Config Mode Commands

Table : Config Mode Commands

<u>Command</u>	<u>Description</u>
aaa	Authentication, Authorization and Accounting
access	Access management
access-list	Access list
aggregation	Aggregation mode
always-on-poe	Enable Always On PoE
banner	Define a banner
clock	Configure time-of-day clock
debug	Debugging functions
default	Set a command to its defaults
dms	Enable DMS Master
do	To run exec commands in the configuration mode
dot1x	IEEE Standard for port-based Network Access Control
enable	Modify enable password parameters
end	Go back to EXEC mode
eps	Ethernet Protection Switching
erps	Ethernet Ring Protection Switching
evc	Ethernet Virtual Connections
event	Trap event severity level
exec-timeout	Auto-logout Timeout
exit	Exit from current mode
green-ethernet	Green Ethernet (Power reduction)
gvrp	Enable GVRP feature
help	Description of the interactive help system
hostname	Set system's network name
hqos	Hierarchical Quality of Service
interface	Select an interface to configure
ip	Interface Internet Protocol configuration commands
ipmc	Ipv4/Ipv6 multicast configuration
ipv6	Ipv6 configuration commands
json	JavaScript Object Notation RPC
lacp	LACP settings
line	Configure a terminal line
lldp	Link Layer Discover Protocol.
Logging	System logging message
loop-protect	Loop protection configuration
mac	MAC table entries/configuration
map-api-key	Set google map key string
mep	Maintenance Entity Point
monitor	Monitoring different system events

mrp-ring	MRP Ring Configuration
mvr	Multicast VLAN Registration configuration
mvrp	Enable MVRP feature globally
no	Negate a command or set its defaults
ntp	Configure NTP
perception	Perception configuration
perf-mon	Performance Monitor
poe	Power Over Ethernet.
port-security	Port security configuration.
privilege	Command privilege parameters
prompt	Set prompt
ptp	Precision time Protocol (1588)
qos	Quality of Service
radius-server	Configure RADIUS
rapid-ring	Set Rapid Ring configurations
rfc2544	RFC2544 performance tests
rmon	Remote Monitoring
router	Routing process
sflow	Statistics flow.
smtp	Set email information
snmp-server	Set SNMP server's configurations
spanning-tree	Spanning Tree protocol
svl	Shared VLAN Learning
switchport	Set VLAN switching mode characteristics
system	Set the SNMP server's configurations
tacacs-server	Configure TACACS+
traffic-test-loop	Traffic Test Loop that can do looping to used for traffic testing like RFC2544 and Y.1564.
udld	Enable UDLD in aggressive or normal mode and set configurable message timer on all fiber-optic ports.
Upnp	Set UpnP configuration
username	Establish User Name Authentication
vlan	VLAN commands
voice	Voice appliance attributes
web	Web
y1564	Y.1564 Ethernet service activation test methodology

Command: terminal

Description: Configure from the terminal. Enter Config mode from Exec mode.

Syntax: **configure terminal** <cr>

Parameters: None.

Example:

```
SISPM1040-3248-L# configure terminal
SISPM1040-3248-L(config)#
```

Command: aaa

Description: Configure Authentication, Authorization and Accounting parameters.

Syntax:

```
aaa accounting { console | telnet | ssh | http | https } tacacs { [ commands <priv_lvl> ] [ exec ] }*1
aaa authentication login { console | telnet | ssh | https } { { local | radius | tacacs } [ { local | radius | tacacs } [ {
local | radius | tacacs } ] ] }
aaa authentication login { http } { { redirect | local | radius | tacacs } [ { redirect | local | radius | tacacs } [ {
redirect | local | radius | tacacs } [ { redirect | local | radius | tacacs } ] ] ] }
aaa authorization { console | telnet | ssh } tacacs commands <priv_lvl> [ config-commands ]
```

Parameters:	accounting	Accounting
	authentication	Authentication
	authorization	Authorization
	console	Configure Console command accounting
	http	Configure HTTP command accounting
	https	Configure HTTPS command accounting
	ssh	Configure SSH command accounting
	telnet	Configure Telnet command accounting
	tacacs	Use TACACS+ for accounting
	commands	Enable command accounting
	exec	Enable EXEC accounting
	<0-15>	Command privilege level. Commands equal and above this level are accounted.
	Login	Login
	console	Configure Console authentication
	http	Configure HTTP authentication
	https	Configure HTTPS authentication
	ssh	Configure SSH authentication
	telnet	Configure Telnet authentication
	local	Use local database for authentication
	radius	Use RADIUS for authentication
	tacacs	Use TACACS+ for authentication
	console	Configure Console command authorization
	ssh	Configure SSH command authorization

telnet	Configure Telnet command authorization
config-commands	Include configuration commands

Example:

```
SISPM1040-3248-L(config)# aaa accounting console tacacs commands 0 exec
SISPM1040-3248-L(config)# aaa authentication login console local
SISPM1040-3248-L(config)# $zation ssh tacacs commands 0 config-commands
SISPM1040-3248-L(config)# aaa authorization ssh tacacs commands 0 config-commands
SISPM1040-3248-L(config)# aaa accounting https tacacs commands 14 exec
SISPM1040-3248-L(config)#
```

Command: access

Description: Configure Access management.

Syntax:

access management

access management <access_id> <access_vid> <start_addr> [to <end_addr>] { [web] [snmp] [telnet] | all }

access management <access_id> <access_vid> <start_addr> [to <end_addr>] { [web] [snmp] [telnet] | all }

Parameters:

<1-16>	ID of access management entry
<1-4095>	The VLAN ID for the access management entry
<ipv4_ucast>	Start Ipv4 unicast address
<ipv6_ucast>	Start Ipv6 unicast address
all	All services
snmp	SNMP service
telnet	TELNET/SSH service
to	End address of the range
web	Web service
<ipv4_ucast>	End Ipv4 unicast address
<cr>	

Example:

```
SISPM1040-3248-L(config)# access management 1 100 192.168.1.77 all
SISPM1040-3248-L(config)# access management 1 100 1.2.3.4 to 1.2.3.9 snmp telnet web
SISPM1040-3248-L(config)# access management <cr>
SISPM1040-3248-L(config)#
```

Messages: % At least one service must be selected.

Access-list Commands

Table : configure access-list Commands

<u>Command</u>	<u>Function</u>
ace	Access list entry
rate-limiter	Rate limiter

Command: **ace**

Description: Configure Access list ACE parameters.

Syntax:

access-list ace <1-512> action [deny | permit]

access-list ace <1-384> action { (deny | permit) [dmac-type | frame-type | ingress | logging | mirror | next | policy | rate-limiter | redirect | shutdown | tag | tag-priority | vid] }

access-list ace <1-512> action filter interface (* | GigabitEthernet | 10GigabitEthernet) [<port_type_list> | dmac-type | frame-type | ingress | logging | mirror | next | policy | rate-limiter | redirect | shutdown | tag | tag-priority | vid]

access-list ace <1-512> action (deny | permit) dmac-type (any | broadcast | multicast | unicast) [frame-type | ingress | logging | mirror | next | policy | rate-limiter | redirect | shutdown | tag | tag-priority | vid]

access-list ace <1-512> action (deny | permit) frame-type { (any [dmac-type | ingress | logging | mirror | next | policy | rate-limiter | redirect | shutdown | tag | tag-priority | vid]) }

access-list ace <1-512> action (deny | permit) frame-type { (arp [arp-flag | arp-opcode | dip | dmac-type | ingress | logging | mirror | next | policy | rate-limiter | redirect | shutdown | sip | smac | tag | tag-priority | vid]) }

access-list ace <1-512> action (deny | permit) frame-type { (etype [dmac | dmac-type | etype-value | ingress | logging | mirror | next | policy | rate-limiter | redirect | shutdown | smac | tag | tag-priority | vid]) }

access-list ace <1-512> action (deny | permit) frame-type { (ipv4 [dip | dmac-type | ingress | ip-flag | ip-protocol | logging | mirror | next | policy | rate-limiter | redirect | shutdown | sip | tag | tag-priority | vid]) }

access-list ace <1-512> action (deny | permit) frame-type { (ipv4-icmp [dip | dmac-type | icmp-code | icmp-type | ingress | ip-flag | ip-protocol | logging | mirror | next | policy | rate-limiter | redirect | shutdown | sip | tag | tag-priority | vid]) }

access-list ace <1-512> action (deny | permit) frame-type { (ipv4-tcp | ipv4-udp) [dip | dmac-type | dport | ingress | ip-flag | logging | mirror | next | policy | rate-limiter | redirect | shutdown | sip | sport | tag | tag-priority | vid]) }

access-list ace <1-512> action (deny | permit) frame-type { (ipv6 | ipv6-udp) [dmac-type | hop-limit | ingress | logging | mirror | next | policy | rate-limiter | redirect | shutdown | sip | tag | tag-priority | vid]) }

access-list ace <1-512> action (deny | permit) frame-type { (ipv6-icmp [dip | dmac-type | icmp-code | icmp-type | ingress | logging | mirror | next | policy | rate-limiter | redirect | shutdown | sip | tag | tag-priority | vid]) }

access-list ace <1-512> action (deny | permit) frame-type { (ipv6-tcp [dmac-type | dport | hop-limit | ingress | logging | mirror | next | policy | rate-limiter | redirect | shutdown | sip | sport | tag | tag-priority | tcp-flag | vid]) }

```

access-list ace <1-512> action ( deny | permit ) ingress{ ( any [ dmac-type | frame-type | logging | mirror | next |
policy | rate-limiter | redirect | shutdown | tag | tag-priority | vid ] ) | { interface ( * | GigabitEthernet |
10GigabitEthernet ) [ <port_type_list> | dmac-type | frame-type | ingress | logging | mirror | next | policy | rate-
limiter | redirect | shutdown | tag | tag-priority | vid ] } }
access-list ace <1-512> action ( deny | permit ) logging [ disable | dmac-type | frame-type | ingress | mirror |
next | policy | rate-limiter | redirect | shutdown | tag | tag-priority | vid ]
access-list ace <1-512> action ( deny | permit ) mirror [ disable | dmac-type | frame-type | ingress | logging |
next | policy | rate-limiter | redirect | shutdown | tag | tag-priority | vid ]
access-list ace <1-512> action ( deny | permit ) next ( <1-512> | last ) [ dmac-type | frame-type | ingress | logging
| mirror | policy | rate-limiter | redirect | shutdown | tag | tag-priority | vid ]
access-list ace <1-512> action ( deny | permit ) policy <0-127> [ dmac-type | frame-type | ingress | logging |
mirror | next | policy-bitmask | rate-limiter | redirect | shutdown | tag | tag-priority | vid ]
access-list ace <1-512> action ( deny | permit ) rate-limiter ( <1-16> | disable ) [ dmac-type | frame-type | ingress
| logging | mirror | next | policy | redirect | shutdown | tag | tag-priority | vid ]
access-list ace <1-512> action ( deny | permit ) redirect { ( disable [ dmac-type | frame-type | ingress | logging |
mirror | next | policy | rate=limiter| shutdown | tag | tag-priority | vid ] ) } | { interface ( * | GigabitEthernet |
10GigabitEthernet ) [ <port_type_list> | dmac-type | frame-type | ingress | logging | mirror | next | policy | rate-
limiter | shutdown | tag | tag-priority | vid ] } }
access-list ace <1-512> action ( deny | permit ) shutdown [ disable | dmac-type | frame-type | ingress | logging |
mirror | next | policy | rate-limiter | redirect | tag | tag-priority | vid ]
access-list ace <1-512> action ( deny | permit ) tag ( any | tagged | untagged ) [ dmac-type | frame-type | ingress
| logging | mirror | next | policy | rate-limiter | redirect | shutdown | tag-priority | vid ]
access-list ace <1-512> action ( deny | permit ) tag-priority ( 0-1 | 0-3 | 2-3 | 4-5 | 4-7 | 6-7 | <0-7> | any ) [
dmac-type | frame-type | ingress | logging | mirror | next | policy | rate-limiter | redirect | shutdown | tag | vid
]
access-list ace <1-512> action ( deny | permit ) vid ( <1-4095> | any ) [ dmac-type | frame-type | ingress | logging
| mirror | next | policy | rate-limiter | redirect | shutdown | tag | tag-priority ]
access-list ace update <1-512> [ action | dmac-type | frame-type | ingress | logging | mirror | next | policy |
rate-limiter | redirect | shutdown | tag | tag-priority | vid ]

```

Parameters:

<1-512>	ACE ID
update	Update an existing ACE
action	Access list action
dmac-type	The type of destination MAC address
frame-type	Frame type
ingress	Ingress
logging	Logging frame information. Note: The logging feature only works when the packet length is less than 1518 (without VLAN tags) and the System Log memory size and logging rate is limited.
Mirror	Mirror frame to destination mirror port
next	insert the current ACE before the next ACE ID
policy	Policy
rate-limiter	Rate limiter
redirect	Redirect frame to specific port

shutdown	Shutdown incoming port. The shutdown feature only works when the packet length is less than 1518 (without VLAN tags).
Tag	Tag
tag-priority	Tag priority
vid	VID field
deny	Deny
filter	Filter
permit	Permit
interface	Select an interface to configure
*	All switches or All ports
GigabitEthernet	Gigabit Ethernet Ports
10GigabitEthernet	10Gigabit Ethernet Ports
<port_type_list>	Port list for all port types
<port_type_list>	Port list in 1/1-28
<port_type_list>	Port list in 1/1-4
any	Don't-care the type of destination MAC address
broadcast	Broadcast destination MAC address
multicast	Multicast destination MAC address
unicast	Unicast destination MAC address
any	Don't-care the frame type
arp	Frame type of ARP
etype	Frame type of EtherType
ipv4	Frame type of Ipv4
ipv4-icmp	Frame type of Ipv4 ICMP
ipv4-tcp	Frame type of Ipv4 TCP
ipv4-udp	Frame type of Ipv4 UDP
ipv6	Frame type of Ipv6
ipv6-icmp	Frame type of Ipv6 ICMP
ipv6-tcp	Frame type of Ipv6 TCP
ipv6-udp	Frame type of Ipv6 UDP
arp-flag	ARP flag
arp-opcode	ARP/RARP opcode field
dip	Destination IP address field
sip	Source IP address field
smac	Source MAC address field
dmac	Destination MAC address field
dmac-type	The type of destination MAC address
etype-value	Ether type value
ip-flag	IP flag
ip-protocol	Ipv4 protocol field
icmp-code	ICMP code field
icmp-type	ICMP type field
dport	TCP/UDP destination port field
sport	TCP/UDP source port field
tcp-flag	TCP flag
hop-limit	Ipv6 hop limiter field
disable	Disable logging
<1-512>	The next ID
last	Place the current ACE to the end of access list

<0-127>	Policy ID
policy-bitmask	The bitmask for policy ID
<1-16>	Rate limiter ID
disable	Disable rate-limiter
disable	Disable
any	Don't-care tagged or untagged
tagged	Tagged
untagged	Untagged
11-16	The range of tag priority
0-3	The range of tag priority
2-3	The range of tag priority
4-5	The range of tag priority
4-7	The range of tag priority
6-7	The range of tag priority
<0-7>	The value of tag priority
any	Don't-care the value of tag priority field
<1-4095>	The value of VID field
any	Don't-care the value of VID field
0x600-0x7ff,0x801-0x805,0x807-0x86dc,0x86de-0xffff>	The value of EtherType field
any	Don't-care the value of EtherType field

Example:

```
SISPM1040-3248-L(config)# access management 1 100 192.168.1.77 all
SISPM1040-3248-L(config)# access-list ace 1 action filter interface GigabitEthernet 1/10
frame-type etype etype-value 0x801 tag tagged vid 100
SISPM1040-3248-L(config)#
```

Command: **rate-limiter**

Description: Configure Access list Rate Limiter parameters.

Syntax: **access-list** rate-limiter [<rate_limiter_list>] { pps <pps_rate> | 10pps <pps10_rate> | 100pps <pps100_rate> | 25kbps <kpbs25_rate> | 100kbps <kpbs100_rate> }

Parameters:

10pps	10 packets per second
25kbps	25k bits per second
<1~16>	Rate limiter ID
10pps	10 packets per second
25kbps	25k bits per second
<0-500000>	Rate value
<0-400000>	Rate value
<cr>	

Example:

```
SISPM1040-3248-L(config)# access-list rate-limiter 1 10pps 10000
SISPM1040-3248-L(config)# access-list rate-limiter 25kbps 5000
SISPM1040-3248-L(config)#
```

Command: aggregation

Description: Configure Aggregation mode.

Syntax: **aggregation** mode { [smac] [dmac] [ip] [port] }*1

Parameters: mode Traffic distribution mode
 dmac Destination MAC affects the distribution
 ip IP address affects the distribution
 port IP port affects the distribution
 smac Source MAC affects the distribution
 <cr>

Example:

```
SISPM1040-3248-L(config)# aggregation mode dmac ip
SISPM1040-3248-L(config)# aggregation mode ip
SISPM1040-3248-L(config)# aggregation mode smac
SISPM1040-3248-L(config)# aggregation mode port
SISPM1040-3248-L(config)#
```

Command: always-on-poe

Description: Enable Always On PoE

Syntax: **always-on-poe** <cr>

Parameters: | Output modifiers
 <cr>

Example:

```
SISPM1040-3248-L(config)# always-on-poe
Always On PoE Status : Enable
SISPM1040-3248-L(config)#
```

Command: banner

Description: Define a banner.

Syntax: **banner** [motd | login | exec] <banner>

Parameters: <line> c banner-text c, where 'c' is a delimiting character
 exec Set EXEC process creation banner
 login Set login banner
 motd Set Message of the Day banner

Example:

```
SISPM1040-3248-L(config)# banner exec LINE
% Entering multi-line text input mode. Type in text and exit the mode using the
delimiting character 'L'. All input after that character will be silently ignore
d. The effective buffer size, i.e. excluding the delimiting characters but inclu
ding any newline characters (e.g. from multi-line input), cannot be longer than
1023.
SISPM1040-3248-L(multiline-input)# L
SISPM1040-3248-L(config)#
```

Command: `clock`

Description: Configure time-of-day clock.

Syntax:

```
clock set <icliDateWord> { <icliTimeWord24> | <icliTimeWord12> { AM | PM } }clock summer-time <word16>
date [ <start_month_var> <start_date_var> <start_year_var> <start_hour_var> <end_month_var>
<end_date_var> <end_year_var> <end_hour_var> [ <offset_var> ] ]
```

```
clock summer-time <word16> recurring [ <start_week_var> <start_day_var> <start_month_var>
<start_hour_var> <end_week_var> <end_day_var> <end_month_var> <end_hour_var> [ <offset_var> ] ]
```

```
clock timezone <word_var> <hour_var> [ <minute_var> [ <subtype_var> ] ]
```

Parameters:

set	set clock
summer-time	Configure summer (daylight savings) time
timezone	Configure time zone
<word10>	yyyy/mm/dd
<word8>	hh:mm:ss
<word16>	name of time zone in summer (the string " is a special syntax that is reserved for null input)
date	Configure absolute summer time
recurring	Configure recurring summer time
<1-12>	Month to start
<1-31>	Date to start
<2000-2097>	Year to start
<hhmm>	Time to start (hh:mm)
<1-12>	Month to end
<1-31>	Date to end
<2000-2097>	Year to end
<hhmm>	Time to end (hh:mm)
<1-1439>	Offset to add in minutes
<word16>	name of time zone (the string " is a special syntax that is reserved for null input)
<-23-23>	Hours offset from UTC
<0-59>	Minutes offset from UTC
<0-9>	Sub type of time zone

Example:

```
SISPM1040-3248-L(config)# clock set 2021/03/09 18:14:30
SISPM1040-3248-L(config)# clock summer-time cdt date 6 15 2021 12:00 9 1 2021 01:00 60
2021-03-09T18:14:31+00:00
SISPM1040-3248-L(config)# clock timezone cst 12 0 0
SISPM1040-3248-L(config)#
```

Messages: *Daylight saving time zone subtype error*

Command: **default**

Description: Set a command to its defaults.

Syntax: **default** access-list rate-limiter [<rate_limiter_list>]

Parameters:

access-list	Access list
rate-limiter	Rate limiter
<1~16>	Rate limiter ID
<cr>	

Example:

```
SISPM1040-3248-L(config)# default access-list rate-limiter 1
SISPM1040-3248-L(config)# default access-list rate-limiter
SISPM1040-3248-L(config)#
```

Command: **dms**

Description: Enable/disable DMS Service Mode and set controller priority level. The Lantronix DMS (Device Management System) is an intelligent management tool embedded in the switch. DMS automatically discovers and displays all devices connected to the switch using standard networking protocols such as LLDP, UpnP, ONVIF, etc. DMS is controlled by the DMS Controller switch, as specified by DMS Service Mode selection.

Syntax: **dms** service-mode { disabled | enabled [priority { high | mid | low | non }] }

Parameters:

service-mode	DMS mode
disabled	DMS mode is disabled
enabled	DMS mode is enabled
priority	DMS priority. You can choose the switch priority level (high, low, mid, non).
High	DMS priority is high (this switch <u>will</u> become the DMS controller switch)
low	DMS priority is low
mid	DMS priority is mid
non	DMS priority is non (this switch will <u>never</u> become the DMS controller switch)
<cr>	

Example:

```
SISPM1040-3248-L(config)# dms mode enabled
SISPM1040-3248-L(config)#
SISPM1040-3166-L(config)# dms service-mode enabled priority high
SISPM1040-3166-L(config)# dms service-mode enabled priority low
SISPM1040-3166-L(config)# dms service-mode enabled priority mid
SISPM1040-3166-L(config)#
```

Command: **do**

Description: To run Exec commands in Config mode.

Syntax: **do** <command>

Parameters: <line> Exec Command
 <cr>

Example:

```
SISPM1040-3248-L(config)# do show version brief
Version       : SISPM1040-3248-L (standalone) v8.50.0149
Build Date    : 2024-04-15T09:29:35+08:00
SISPM1040-3248-L(config)#
SISPM1040-3248-L(config)# do show vlan
VLAN  Name                Interfaces
-----
1     default              Gi 1/1-28 10G 1/1-4

SISPM1040-3166-L(config)#
```

Command: **dot1x**

Description: Configure IEEE Standard for port-based Network Access Control

Syntax: **dot1x** authentication timer inactivity <v_10_to_100000>
dot1x authentication timer re-authenticate <v_1_to_3600>
dot1x feature { [guest-vlan] [radius-qos] [radius-vlan] }*1
dot1x guest-vlan <value>
dot1x guest-vlan supplicant
dot1x max-reauth-req <value>
dot1x re-authentication
dot1x system-auth-control
dot1x timeout quiet-period <v_10_to_1000000>
dot1x timeout tx-period <v_1_to_65535>

Parameters:

authentication	Authentication
feature	Globally enables/disables a dot1x feature functionality
guest-vlan	Guest VLAN
max-reauth-req	The number of times a Request Identity EAPOL frame is sent without response before considering entering the Guest VLAN
re-authentication	Set Re-authentication state
system-auth-control	Set the global NAS state
timer	timer
timeout	quiet-period timeout
timeout	tx-period timeout
inactivity	Time in seconds between check for activity on successfully authenticated MAC addresses.
Re-authenticate	The period between re-authentication attempts in seconds
radius-qos	Globally enables/disables state of RADIUS-assigned QoS.
Radius-vlan	Globally enables/disables state of RADIUS-assigned VLAN.
<1-4095>	Guest VLAN ID used when entering the Guest VLAN.
Supplicant	The switch remembers if an EAPOL frame has been received on the port for the life-time of the port. Once the switch considers whether to enter the Guest VLAN, it will first check if this option is enabled or disabled. If disabled (unchecked, default), the switch will only enter the Guest VLAN if an EAPOL frame has not been received on the port for the life-time of the port. If enabled (checked), the switch will consider entering the Guest VLAN even if an EAPOL frame has been received on the port for the life-time of the port.
<1-255>	number of times (ma- reauth-req)
quiet-period	Time in seconds before a MAC-address that failed authentication gets a new authentication chance.
<10-1000000>	seconds of quiet-period
tx-period	the time between EAPOL retransmissions.
<1-65535>	seconds of tx-period

Example:

```
SISPM1040-3248-L(config)# dot1x feature guest-vlan
```

```
SISPM1040-3248-L(config)# dot1x auth timer inactivity 50000
SISPM1040-3248-L(config)# dot1x feature guest-vlan radius-qos radius-vlan
SISPM1040-3248-L(config)# dot1x guest-vlan 1
SISPM1040-3248-L(config)# dot1x max-reauth-req 75
SISPM1040-3248-L(config)# dot1x re-authentication
SISPM1040-3248-L(config)# dot1x system-auth-control
SISPM1040-3248-L(config)# dot1x timeout quiet-period 6000
SISPM1040-3248-L(config)# dot1x timeout tx-period 8000
SISPM1040-3248-L(config)#
```

Command: **enable**

Description: Modify enable password parameters.

Syntax: **enable** password [level <priv>] <password>
enable secret { 0 | 5 } [level <priv>] <password>

Parameters: password Assign the privileged level clear password
secret Assign the privileged level secret
<word32> The UNENCRYPTED (clear-text) password
level Set exec level password
11 Specifies an UNENCRYPTED password will follow
5 Specifies an ENCRYPTED secret will follow
<1-15> Level number for password

Example:

```
SISPM1040-3248-L(config)# enable password level 15 admin
SISPM1040-3248-L(config)# enable secret 0 level 15 admin
SISPM1040-3248-L(config)#
```

Command: **end**

Description: Go back to EXEC mode from Config mode or from Interface Config mode.

Syntax: **end** <cr>

Parameters: **end** Go back to EXEC mode
<cr>

Example:

```
SISPM1040-3248-L(config)# end
SISPM1040-3248-L#

SISPM1040-3248-L(config)# interface *
SISPM1040-3248-L(config-if)# end
SISPM1040-3248-L#
```

Command: **eps**

Description: Configure Ethernet Protection Switching.

Syntax:

```

eps <inst> 1plus1 { bidirectional | { unidirectional [ aps ] } }
eps <inst> command { lockout | forced | 36arame | 36arame | exercise | freeze | lockoutlocal }
eps <inst> domain { port | tunnel-tp | pw } architecture { 1plus1 | 1for1 } work-flow { <flow_w> | <port_type>
<port_w> } protect-flow { <flow_p> | <port_type><port_p> }
eps <inst> holdoff <hold>
eps <inst> mep-work <mep_w> mep-protect <mep_p> mep-aps <mep_aps>
eps <inst> revertive { 10s | 30s | 5m | 6m | 7m | 8m | 9m | 10m | 11m | 12m | {wtr-value <wtr_value> } }

```

Parameters:

<1-100>	The EPS instance number.
1plus1	EPS 1+1 architecture.
Aps	EPS 1+1 unidirectional with APS protection type.
Command	EPS command.
Domain	The domain of the EPS.
Holdoff	Hold off timer.
Mep-work	Working MEP instance.
Revertive	Revertive EPS.
Bidirectional	EPS 1+1 bidirectional protection type.
Unidirectional	EPS 1+1 unidirectional protection type.
Exercise	Exercise of the protocol – not traffic effecting. This is only allowed in ‘Bidirectional’ protection type.
Forced	Force switch normal traffic to protection.
Freeze	Local Freeze of EPS.
Lockout	Lockout of protection.
Lockoutlocal	Local lockout of EPS.
36arame	Manual switch normal traffic to protection.
36arame	Manual switch normal traffic to working. This is only allowed in ‘non-revertive’ mode.
10m	WTR is 10 min.
10s	WTR is 10 sec.
11m	WTR is 11 min.
12m	WTR is 12 min.
30s	WTR is 30 sec.
5m	WTR is 5 min.
6m	WTR is 6 min.
7m	WTR is 7 min.
8m	WTR is 8 min.
9m	WTR is 9 min.
port	This EPS is protecting in the Port domain.
Pw	This EPS is protecting in the MPLS-TP Pseudo-Wire domain.
Tunnel-tp	This EPS is protecting in the MPLS-TP tunnel domain.
Architecture	The EPS architecture.

1for1	The architecture is 1 for 1.
1plus1	The architecture is 1 plus 1.
Work-flow	The working flow instance that the EPS is related to.
GigabitEthernet	1 Gigabit Ethernet Port
10GigabitEthernet	10 Gigabit Ethernet Port
<uint>	The working flow instance number when not in the port domain.
<port_type_id>	Port ID in 1/1-28
protect-flow	The protecting flow instance that the EPS is related to.
<uint>	The hold off timer value in 100 ms. Max 10 sec.
<uint>	Working MEP instance number.

Example:

```
SISPM1040-3248-L(config)# eps 1 1plus1 unidirectional aps
SISPM1040-3248-L(config)# eps 2 command forced
SISPM1040-3248-L(config)# eps 1 holdoff 10
SISPM1040-3248-L(config)# eps 1 revertive 30s
SISPM1040-3248-L(config)#
```

Message:

Error: EPS instance is not created

In Port domain, work-flow and protect-flow must be <port_type_id>

Command: erps

Description: Configure Ethernet Ring Protection Switching.

Syntax:

```

erps <group> guard <guard_time_ms>
erps <group> holdoff <holdoff_time_ms>
erps <group> major port0 interface <port_type> <port0> port1 interface <port_type> <port1> [ interconnect ]
erps <group> mep port0 sf <p0_sf> aps <p0_aps> port1 sf <p1_sf> aps <p1_aps>
erps <group> revertive <wtr_time_minutes>
erps <group> rpl { owner | neighbor } { port0 | port1 }
erps <group> sub port0 interface <port_type> <port0> { { port1 interface <port_type> <port1> } | { interconnect
<major_ring_id> } } [ virtual-channel ]
erps <group> topology-change propagate
erps <group> version { 1 | 2 }
erps <group> vlan { none | [ add | remove ] <vlans> }

```

Parameters:	1-64	ERPS group number
	guard	Guard
	holdoff	Hold-off time
	major	Major ring
	mep	MEP
	revertive	Revertive
	rpl	Ring Protection Link
	sub	Sub-ring
	topology-change	Topology Change
	version	Version
	vlan	VLAN
	10-2000	Guard time in ms
	0-10000	Hold-off time in ms
	port0	ERPS Port 0 interface
	interface	Select an interface to configure
	GigabitEthernet	Gigabit Ethernet Ports
	10GigabitEthernet	10Gigabit Ethernet Ports
	<port_type_list>	Port list in 1/1-28
	<port_type_list>	Port list in 1/1-4
	port1	ERPS Port 1 interface
	interconnect	Major ring is interconnected
	sf	Signal Fail
	<1-3124>	Index of Port 0 SignalFail MEP
	aps	Automatic Protection Switching
	<1-3124>	Index of Port 0 APS MEP
	port1	ERPS Port 1 interface
	<1-3124>	Index of Port 1 SignalFail MEP
	<1-3124>	Index of Port 1 APS MEP

Command: **evc**

Description: Configure Ethernet Virtual Circuit for an interface.

Syntax:

```
evc [ update ] <evc_id> [ name <evc_name> ] { [ vid <evc_vid> ] [ ivid <ivid> ] [ interface ( <port_type> [ <port_list> ] ) ] { [ leaf { [ vid <leaf_vid> ] [ ivid <leaf_ivid> ] [ interface { ( <port_type> [ <leaf_port_list> ] ) | none } ] } *1 ] } [ learning [ disable ] ] [ nni { [ ingress-map { <imap> | disable } ] [ egress-map { <emap> | disable } ] } *1 ] [ policer { <policer_id> | none | discard } ] [ inner-tag add { [ type { none | c-tag | s-tag | s-custom-tag } ] [ vid-mode { normal | tunnel } ] [ vid <it_add_vid> ] [ preserve [ disable ] ] [ pcp <it_add_pcp> ] [ dei <it_add_dei> ] } *1 ] [ outer-tag add vid <ot_add_vid> ] [ pw [ <pw_num_list> ] [ split-horizon <pw_num_list_split_horizon> ] ]
```

```
evc ece [ update ] <ece_id> [ next { <ece_id_next> | last } ] [ lookup { basic | advanced } ] [ interface ( <port_type> [ <port_list> ] ) ] [ smac { <smac> | any } ] [ dmac { <dmac> | unicast | multicast | broadcast | any } ] [ outer-tag { [ match { [ type { untagged | tagged | c-tagged | s-tagged | any } ] [ vid { <ot_match_vid> | any } ] [ pcp { <ot_match_pcp> | any } ] [ dei { <ot_match_dei> | any } ] } *1 ] [ add { [ mode { enable | disable } ] [ vid <ot_add_vid> ] [ preserve [ disable ] ] [ pcp-mode { classified | fixed | mapped } ] [ pcp <ot_add_pcp> ] [ dei-mode { classified | fixed | dp } ] [ dei <ot_add_dei> ] } *1 ] } *1 ] [ inner-tag { [ match { [ type { untagged | tagged | c-tagged | s-tagged | any } ] [ vid { <it_match_vid> | any } ] [ pcp { <it_match_pcp> | any } ] [ dei { <it_match_dei> | any } ] } *1 ] [ add { [ type { none | c-tag | s-tag | s-custom-tag } ] [ vid <it_add_vid> ] [ preserve [ disable ] ] [ pcp-mode { classified | fixed | mapped } ] [ pcp <it_add_pcp> ] [ dei-mode { classified | fixed | dp } ] [ dei <it_add_dei> ] } *1 ] } *1 ] [ frame-type { any | { ipv4 [ proto { <pr4> | udp | tcp | any } ] [ dscp { <dscp4> | any } ] [ sip { <sip4> | any } ] [ dip { <dip4> | any } ] [ fragment { yes | no | any } ] [ sport { <sp4> | any } ] [ dport { <dp4> | any } ] } | { ipv6 [ proto { <pr6> | udp | tcp | any } ] [ dscp { <dscp6> | any } ] [ sip { <sip6> | any } ] [ dip { <dip6> | any } ] [ sport { <sp6> | any } ] [ dport { <dp6> | any } ] } | { etype [ etype-value { <etype_value> | any } ] [ etype-data { <etype_data> | any } [ <etype_mask> ] } ] } | llc [ dsap { <dsap> | any } ] [ ssap { <ssap> | any } ] [ control { <control> | any } ] [ llc-data { <llc_data> | any } [ <llc_mask> ] } ] } | { snap [ oui { <oui> | any } ] [ pid { <pid> | any } ] } | { l2cp { stp | pause | lacp | lamp | loam | dot1x | elmi | pb | pb-gvrp | lldp | gmrp | gvrp | uld | pagp | pvst | cisco-vlan | cdp | vtp | dtp | cisco-stp | cisco-cfm } } } ] [ direction { both | uni-to-nni | nni-to-uni } ] [ rule-type { both | rx | tx } ] [ tx-lookup { vid | pcp-vid | isdx } ] [ l2cp { [ mode { tunnel | peer | forward | discard } ] [ tmac { cisco | custom } ] } *1 ] [ evc { <evc_id> | none } ] [ policer { <policer_id> | none | discard | evc } ] [ pop <pop> ] [ policy <policy_no> ] [ cos { <cos> | disable } ] [ dpl { <dpl> | disable } ] [ ingress-map { <imap> | disable } ]
```

```
evc encapsulation [ update ] <encap_id> { [ vid <vlan_id> ] [ egress-map { <emap> | disable } ] } *1
```

```
evc l2cp [ update ] <l2cp_profile> <l2cp_id> { [ { peer | forward | discard } ] [ class { <cosid> | disable } ] } *1
```

Parameters:

<1-454>	EVC identifier
ece	EVC Control Entry
encapsulation	Setup EVC encapsulation
l2cp	Layer 2 Control Protocol
update	Update existing entry
ivid	Setup internal EVC VLAN ID
leaf	Setup E-tree leaf options
learning	Setup learning
name	EVC name
nni	Setup NNI options

pw	Attach EVC to MPLS-TP Pseudo-Wires
vid	Setup EVC VLAN ID
<1-1362>	ECE identifier
update	Update existing entry
direction	Setup ECE direction
dmac	Setup matched DMAC
evc	EVC mapping
frame-type	Setup matched frame type
ingress-map	Setup QoS ingress map
inner-tag	Setup inner tag options
interface	Setup UNI
l2cp	Setup L2CP frame options
next	Setup the ECE ID of the next entry
outer-tag	Setup outer tag options
policy	Setup ACL policy
pop	Setup tag popping
smac	Setup matched SMAC
<0-907>	Encapsulation ID
<0-62>	L2CP profile
<1-454>	EVC identifier
nni	Setup NNI options
pw	Attach EVC to MPLS-TP Pseudo-Wires
egress-map	Setup QoS egress map
ingress-map	Setup QoS ingress map
<1~50>	List of MPLS-TP Pseudo-Wire numbers
learning	Setup learning
nni	Setup NNI options
split-horizon	Attach EVC to MPLS-TP split-horizon Pseudo-Wires
both	Bidirectional traffic flow
nni-to-uni	NNI-to-UNI traffic flow
uni-to-nni	UNI-to-NNI traffic flow
<mac_addr>	Matched DMAC
any	Match any DMAC
broadcast	Match broadcast DMAC
multicast	Match multicast DMAC
unicast	Match unicast DMAC
<1-454>	EVC identifier
none	Map to no EVC ID
any	Match any frame type
etype	Match Ethernet Type frames
ipv4	Match Ipv4 frames
ipv6	Match Ipv6 frames
l2cp	Match L2CP frame

llc	Match LLC frames
snap	Match SNAP frames
<0-255>	Ingress QoS map ID
disable	Disable ingress QoS map
*	All switches or All ports
GigabitEthernet	1 Gigabit Ethernet Port
10GigabitEthernet	10 Gigabit Ethernet Port
mode	Setup L2CP mode
tmac	Setup L2CP tunnel DMAC
<1-1362>	Select ECE ID of an existing entry
last	Make the ECE the last entry
<0-127>	ACL policy
<0-2>	Number of tags popped
<mac_addr>	Matched SMAC
any	Match any SMAC
<0-4095>	EVC leaf VLAN ID
<cr>	

Example:

```
SISPM1040-3248-L(config)# evc update 1 ivid 10
SISPM1040-3248-L(config)# evc ece 1
SISPM1040-3248-L(config)# evc 1 ivid 10 leaf nni egress-map 1 ingress-map 42aramet
SISPM1040-3248-L(config)#
```

Command: event

Description: Configure Trap event severity level.

Syntax:

```
event group { AC-Power | ACL | ACL-Log | Access-Mgmt | Auth-Failed | AUTO-SAVING | Cold-Start | Config-Info
| Digital-Out | Firmware-Upgrade | Import-Export | LACP | Login | Logout | Mgmt-IP-Change | Module-Change |
NAS | Password-Change | Port-Security | Spanning-Tree | Warm-Start | DC-Power | BCS-Protection | DMS |
Dying-Gasp | PoE-Auto-Check | Poe-Auto-Power-Reset | FAN | ZTU-FAIL | Surveillance | NTP-Sync | SCP-Success
| SCP-Fail | PoE-PD-On | PoE-PD-Off | Over-Max-PoE-Power-Limitation | PoE-PD-Over-Current } { level <lvl> |
syslog { enable | disable } | trap { enable | disable } | smtp { enable | disable } | ipush { enable | disable } }
```

```
event group { DI-1-Abnormal | DI-1-Normal | Link-Status | Loop-Protect | Temperature | Voltage | RING-Break |
RING-Error | MRP-Event } { level <lvl> | syslog { enable | disable } | trap { enable | disable } | smtp { enable |
disable } | ipush { enable | disable } | digital-out { enable | disable } }
```

Parameters:	group	Configure trap event severity level
	AC-Power	Group ID AC Power
	ACL	Group ID ACL
	ACL-Log	Group ID ACL Log
	Access-Mgmt	Group ID Access Management
	Auth-Failed	Group ID Auth Fail
	Cold-Start	Group ID Cold Start
	Config-Info	Group ID Config Info
	DC-Power	Group ID DC Power
	DI-1-Abnormal	Group ID DI 1 Abnormal
	DI-1-Normal	Group ID DI 1 Normal
	DMS	Group ID DMS
	Digital-Out	Group ID Digital Out
	Firmware-Upgrade	Group ID Firmware Upgrade
	Import-Export	Group ID Import Export
	LACP	Group ID LACP
	Login	Group ID Login
	Logout	Group ID Logout
	Loop-Protect	Group ID Loop Protect
	MRP-Event	Group ID MRP
	Mgmt-IP-Change	Group ID Management IP Change
	Module-Change	Group ID Module Change
	NAS	Group ID NAS
	NTP-Sync	Group ID NTP Sync
	Over-Max-PoE-Power-Limitation	Group ID Over Max PoE Power Limitation
	Password-Change	Group ID Password Change
	PoE-PD-Off	Group ID PoE PD Off
	PoE-PD-On	Group ID PoE PD On
	PoE-PD-Over-Current	Group ID PoE PD Over Current
	Poe-Auto-Power-Reset	Group ID PoE Auto Power Reset

Port-Security	Group ID Port Security
RING-Break	Group ID Rapid Ring Break
RING-Error	Group ID Rapid Ring Error
SCP-Fail	Group ID SCP Fail
SCP-Success	Group ID SCP Success
Spanning-Tree	Group ID Spanning Tree
Temperature	Group ID Temperature
Voltage	Group ID Voltage
Warm-Start	Group ID Warm Start
digital-out	digital-out mode
level	Severity level
smtp	smtp mode
syslog	syslog mode
trap	trap mode
<0-7>	<0> Emergency ,<1> Alert ,<2> Critical ,<3> Error ,<4> Warning ,<5> Notice ,<6> Informationl ,<7> Debug
disable	digital-out mode disable
enable	digital-out mode enable
disable	smtp mode disable
enable	smtp mode enable
disable	syslog mode disable
enable	syslog mode enable
disable	trap mode disable
enable	trap mode enable
digital-out	digital-out mode

Example:

```
SISPM1040-3248-L(config)# event group NTP-Sync trap enable
SISPM1040-3248-L(config)# event group lacp trap enable
SISPM1040-3248-L(config)# event group mrp smtp enable
SISPM1040-3248-L(config)# event group mrp trap enable
SISPM1040-3248-L(config)# event group RING-Break digital-out enable
SISPM1040-3248-L(config)# event group RING-Error level 4
SISPM1040-3248-L(config)#
```

Command: `exec-timeout`

Description: Set Auto-logout Timeout period.

Syntax: `exec-timeout autologout { 0 | 1 | 2 | 3 | 4 | 5 | 10 | 20 | 30 | 40 | 50 | 60 }`

Parameters:

<code>autologout</code>	automatic logout
<code>off</code>	(No auto-logout timeout period)
<code>1min</code>	
<code>10</code>	10min (default)
<code>2</code>	2 minutes
<code>20</code>	20 minutes
<code>3</code>	3 minutes
<code>30</code>	30 minutes
<code>4</code>	4 minutes
<code>40</code>	40 minutes
<code>5</code>	5 minutes
<code>50</code>	50 minutes
<code>60</code>	60 minutes

Example:

```
SISPM1040-3248-L(config)# exec-timeout autologout 60
SISPM1040-3248-L(config)# exec-timeout autologout 0
SISPM1040-3248-L(config)#
```

After you change the Auto-Logout timeout and then log out and log back in, the Auto-Logout timeout setting will be the setting saved to the start-up config file. When the Auto-Logout timeout setting is changed, it directly writes to running-config.

To save the timeout change to start-up config, you must execute a save to startup-config.

To examine the running-config, run the CLI command “showing running-config”.

To save the timeout change into startup-config, you must do a save to startup-config and then reboot the switch.

- When you power on the switch, it will get the settings from startup-config.
- When you logout and login (without switch reboot), the switch will get the timeout settings from startup-config.
- When you reload defaults, the switch will get the timeout settings default-config.

For the “Save to start-up config” behavior, if you don’t save the config, when you change the timeout setting but logout, at the next login the timeout setting remains unchanged as the setting in start-up config.

If you save timeout setting to start-up config:	If you don't save timeout setting to start-up config:
When you change the timeout setting and save to startup-config (click the disc icon), the changed timeout setting will be applied to running-config and start-up config immediately.	When the you change the timeout setting (without save to startup-config), the timeout change will be applied to running-config immediately.
After Logout and login, the timeout setting will be the setting saved in start-up config.	After Logout and login, the timeout setting will be the setting saved in start-up configure.
After a switch reboot, the timeout setting will be the setting saved in start-up config.	After you reboot the switch, the timeout setting will be the setting saved in start-up config.

Command: **exit**

Description: Exit from current mode.

Syntax: **exit** <cr>

Parameters: None.

Example:

```
SISPM1040-3248-L(config)# exit
SISPM1040-3248-L# exit
Username:
```

Command: **green-ethernet**

Description: Configure Green Ethernet (Power reduction)

Syntax: **green-ethernet** eee optimize-for-power

Parameters:

eee Powering down of PHYs when there is no traffic.

Optimize-for-power Set if EEE shall be optimized for least power consumption (else optimized for least traffic latency).

<cr>

Example:

```
SISPM1040-3248-L(config)# green-ethernet eee optimize-for-power
SISPM1040-3248-L(config)#
```

Command: **gvrp**

Description: Enable GVRP feature

Syntax:

gvrp

gvrp max-vlans <maxvlans>

gvrp time { [join-time <join_time>] [leave-time <leave_time>] [leave-all-time <leave_all_time>] }*1

Parameters:

max-vlans	Number of simultaneously VLANs that GVRP can control
time	Configure GARP protocol timer parameters. IEEE 802.1D-2004, clause 12.11.
join-time	Set GARP protocol parameter JoinTime.
Leave-all-time	Set GARP protocol parameter LeaveAllTime.
Leave-time	Set GARP protocol parameter LeaveTime.
<1-20>	join-time in units of centiseconds. Range is 1-20. Default is 20.
<1000-5000>	Leave-all-time in units of centiseconds Range is 1000-5000. Default is 1000.
<60-300>	leave-time in units of centiseconds. Range is 60-300. Default is 60.
<1-4094>	gvrp max-vlans
<cr>	

Example:

```
SISPM1040-3248-L(config)# gvrp time join-time 10 leave-all-time 2000 leave-time 90
SISPM1040-3248-L(config)# gvrp max-vlans 333
SISPM1040-3248-L(config)#
```

Messages: %% Failed to configure the number of VLANs managed by GVRP.

% (The GARP application is currently enabled – disable it in order to configure its parameters.)

Command: **help**

Description: Description of the interactive help system.

Syntax: **help** <cr?>

Parameters: None.

Example:

```
SISPM1040-3248-L(config)# help
```

Help may be requested at any point in a command by entering a question mark '?'. If nothing matches, the help list will be empty and you must backup until entering a '?' shows the available options.

Two styles of help are provided:

Full help is available when you are ready to enter a command argument (e.g. 'show ?') and describes each possible argument.

Partial help is provided when an abbreviated argument is entered and you want to know what arguments match the input (e.g. 'show pr?').

```
SISPM1040-3248-L(config)#
```

Command: **hostname**

Description: Set system's network name.

Syntax: **hostname** <hostname>

Parameters: <line128> This system's network name
 <cr>

Example:

```
SISPM1040-3248-L(config)# hostname sisp1040-3248-1
```

```
sispm1040-3248-1(config)# hostname SISPM1040-3248-L
```

```
SISPM1040-3248-L(config)# hostname BobB
```

```
BobB(config)# hostname SISPM1040-3248-L
```

```
SISPM1040-3248-L(config)#
```

Command: ip

Description: Configure Internet Protocol command parameters in Config mode.

Syntax:

ip arp inspection

ip arp inspection entry interface <port_type> <in_port_type_id> <vlan_var> <mac_var> <ipv4_var>

ip arp inspection translate [interface <port_type> <in_port_type_id> <vlan_var> <mac_var> <ipv4_var>]

ip arp inspection vlan <in_vlan_list>

ip arp inspection vlan <in_vlan_list> logging { deny | permit | all }

ip dhcp relay

ip dhcp relay information option

ip dhcp relay information policy { drop | keep | replace }

ip dhcp server per-port

ip dhcp server per-port [vlan { <portPortVLAN> }]

ip dhcp snooping

ip dhcp vlan <vid>

ip dhcp vlan <vid> <start_ip> <end_ip> <lease> <mask> <gateway> <dns>

ip dns proxy

ip domain name { <v_domain_name> | dhcp [ipv4 | ipv6] [interface vlan <v_vlan_id_dhcp>] }

ip helper-address <v_ipv4_ucast>

ip http port <port>

ip http secure-certificate { upload <url_file> [pass-phrase <pass_phrase>] | generate }

ip http secure-server port <port>

ip igmp host-proxy [leave-proxy]

ip igmp snooping

ip igmp snooping vlan <v_vlan_list>

ip igmp ssm-range <v_ipv4_mcast> <ipv4_prefix_length>

ip igmp unknown-flooding

ip link-local interface <ifc>

ip name-server [<order>] { <v_ipv4_ucast> | { <v_ipv6_ucast> [interface vlan <v_vlan_id_static>] } | dhcp [ipv4 | ipv6] [interface vlan <v_vlan_id_dhcp>] }

ip route <v_ipv4_addr> <v_ipv4_netmask> <v_ipv4_gw> [<v_distance>]

ip routing

ip scp server { enable | disable }

ip source binding interface <port_type> <in_port_type_id> <vlan_var> <ipv4_var><mac_var>

ip ssh keyregen

ip telnet port <port>

ip verify source

ip verify source translate

Parameters:

arp	Address Resolution Protocol
dhcp	Dynamic Host Configuration Protocol
dns	Domain Name System
domain	IP DNS Resolver

helper-address	DHCP relay server
http	HTTP server
igmp	Internet Group Management Protocol
link-local	Link-Local address binding interface
name-server	Domain Name System
route	Add IP route
routing	Enable routing for Ipv4 and Ipv6
scp	Secure copy function
source	source command
ssh	Secure Shell
telnet	Telnet
verify	verify command
inspection	ARP inspection
entry	ARP inspection entry
translate	ARP inspection translate all entries
vlan	ARP inspection VLAN setting
interface	ARP inspection entry interface configuration
GigabitEthernet	1 Gigabit Ethernet Port
10GigabitEthernet	10 Gigabit Ethernet Port
<port_type_id>	Port ID in 1/1-28
<vlan_id>	Select a VLAN id to configure
<mac_ucast>	Select a MAC address to configure
<ipv4_ucast>	Select an IP Address to configure
relay	DHCP relay agent configuration
server	Enable DHCP server
snooping	DHCP snooping
vlan	VLAN interface
nformation	DHCP information option (Option 82)
option	DHCP option
policy	Policy for handling the receiving DHCP packet already include the information option
drop	Drop the package when receive a DHCP message that already contains relay information
keep	Keep the original relay info when receive a DHCP message that already contains it
replace	Replace the original relay info when receive a DHCP message that already contains it
per-port	Enable DHCP server per port
<vlan_id>	VLAN ID
vlan	DHCP server per port VLAN
<vlan_id>	Set DHCP server per port VLAN
<ipv4_ucast>	Start IP
<vlan_id>	VLAN ID
<ipv4_ucast>	Start IP
<ipv4_ucast>	End IP
<uint>	Address lease time in second
<ipv4_netmask>	Network mask

<ipv4_ucast>	Default routers
<ipv4_ucast>	DNS servers
proxy	DNS proxy service
name	Define the default domain name
<domain_name>	Default domain name
dhcp	Dynamic Host Configuration Protocol
interface	Select an interface to configure
ipv4	DNS setting is derived from DHCPv4
ipv6	DNS setting is derived from DHCPv6; Default selection
<ipv4_ucast>	IP address of the DHCP relay server
port	Service port number
secure-certificate	HTTPS certificate
secure-server	secure web server
<1-65534>	Port number
generate	Generate a new self-signed RSA certificate
upload	Upload a certificate PEM file
<url_file>	Uniform Resource Locator. It is a specific character string that constitutes a reference to a resource. Syntax: <protocol>://[<username>[:<password>]@]<host>[:<port>][/<path>]/<file_name> If the following special characters: space !"#%&'()*+/,;:;<=>?@[\\]^_{ }~ need to be contained in the input URL string, they should be percent-encoded. A valid file name is a text string drawn from alphabet (A-Za-z), digits (0-9), dot (.), hyphen (-), under score (_). The maximum length is 63 and hyphen must not be first character. The file name content that only contains '.' is not allowed.
Port	Service port number
<1-65534>	Port number
host-proxy	IGMP proxy configuration
snooping	Snooping IGMP
ssm-range	Ipv4 address range of Source Specific Multicast
unknown-flooding	Flooding unregistered Ipv4 multicast traffic
leave-proxy	IGMP proxy for leave configuration
interface	Select an interface to configure
<vlan_id>	VLAN IDs 1-4094
<1-4>	Preference of DNS server. Default selection is 1
<ipv4_ucast>	A valid Ipv4 unicast address
<ipv6_ucast>	A valid Ipv6 unicast address
ipv6	DNS setting is derived from DHCPv6
<ipv4_ucast>	Gateway
<1-255>	Distance value for this route
server	support scp server
disable	Set mode to scp Disable
enable	Set mode to scp Enable
binding	IP source binding

interface	IP source binding entry interface configuration
keyregen	Regenerate ssh key
port	Service port number
<1-65534>	Port number
source	verify source
translate	IP verify source translate all entries

Example 1:

```

SISPM1040-3248-L(config)# ip igmp snooping
SISPM1040-3248-L(config)# ip verify source
SISPM1040-3166-L(config)# ip ssh keyregen
W ssh 02:50:34 143/process-daemon.cxx#235: Warning: ssh_showkey-253 STDOUT>
Public key portion is:
 521 ecdsa-sha2-nistp521 AAAAE2VjZHNhLXNoYTItbmlzdHA1MjEAAAABmlzL2ZHA1MjEAAACFBAH
cssj2mnbkAiYxiC86TydHEj0xuw8H5HG7nRYtpAgyuL9wLMuB34LtycW3Tn3kJtUrDBrU/4R1DJENUxr
u/EX7mgCrV5oVEe/MOJJUCfNgnN2RGXCrzXELeEqIq2j1La8Gnnl80v2YofC+zcbrh4leyP7MVgl3325
R4G0PeGcC48QH/g==
Fingerprint: md5 b5:75:6a:10:1a:0d:90:6e:60:de:a9:8d:ac:88:6b:a4
SISPM1040-3166-L(config)# ip scp server disable
SISPM1040-3166-L(config)# ip scp server enable
SISPM1040-3248-L(config)# ip arp inspection translate interface GigabitEthernet 1/12 1
1a-2b-3c-4d-5f-66 192.168.1.90
SISPM1040-3248-L(config)# ip dhcp relay information option
SISPM1040-3248-L(config)# ip dhcp relay information policy drop
SISPM1040-3248-L(config)# ip dhcp relay information policy keep
SISPM1040-3248-L(config)# ip dhcp relay information policy replace
SISPM1040-3248-L(config)# ip dhcp server per-port
SISPM1040-3248-L(config)# ip dhcp server per-port vlan 1
SISPM1040-3248-L(config)# ip dhcp server per-port vlan 10
SISPM1040-3248-L(config)# ip dhcp snooping
SISPM1040-3248-L(config)# ip dhcp vlan 1 10.0.9.88 10.0.9.99 300 255.255.255.0 100.10.1.10
192.168.1.50
SISPM1040-3248-L(config)# ip dns proxy
SISPM1040-3248-L(config)# ip domain name BobB
SISPM1040-3248-L(config)# ip domain name dhcp interface vlan 1
SISPM1040-3248-L(config)# ip helper-address 1.2.3.4
SISPM1040-3248-L(config)# ip http port 345
SISPM1040-3248-L(config)# ip http secure-certificate generate
SISPM1040-3248-L(config)# ip http secure-server port 777
SISPM1040-3248-L(config)# ip igmp host-proxy leave-proxy
SISPM1040-3248-L(config)# ip link-local interface 1
SISPM1040-3248-L(config)# ip name-server 1 1.2.3.4
SISPM1040-3248-L(config)# ip routing
SISPM1040-3248-L(config)# ip scp server enable
SISPM1040-3166-L(config)#

```

Example 2:

```
SISPM1040-3248-L(config)# ip ssh keyregen
W ssh 01:48:57 140/process-daemon.cxx#235: Warning: ssh_showkey-356 STDOUT>
Public key portion is:
 521 ecdsa-sha2-nistp521 AAAAE2VjZHNhLXNoYTItbmlzdHA1MjEAAAABmlzdHA1MjEAAACFBAC
1XWGHZq2WHrbKj6RILAhwbxBfHRIkCCzHBwSmg1D1Do9rGjJgyXY03LswxsSbnJUMPBnxbdggy4Y5ts5
om5bnqwHfNjb+pJWH8+RYJ6qNDcvfvosPfeBMBIbHsAPFV/2LimtNByu296ziFxQBEFb1EsG99na5jB+
6BqaqpJuukiWp5Q==
Fingerprint: md5 5d:a1:37:0e:a0:0d:36:0c:4c:49:41:3e:6f:67:23:be
SISPM1040-3248-L(config)# ip verify source translate
IP Source Guard:
    Translate 0 dynamic entries into static entries.
```

Messages:

```
ARP Inspection: Don't find the dynamic entry.
VLAN 10 is not configured.
Duplicate server ports : Telnet (23), SSH (22), HTTP (345), HTTPS (443)
VLAN ID 100 is not existed. Please create it and set its IP.
% Failed to add route.
% Failed to create interface vlan 10
```

Command: **ipmc**

Description: Ipv4/Ipv6 multicast configuration.

Syntax:

ipmc profile**ipmc** profile <profile_name>**ipmc** range <entry_name> { <v_ipv4_mcast> [<v_ipv4_mcast_1>] | <v_ipv6_mcast> [<v_ipv6_mcast_1>] }

Parameters:	profile	IPMC profile configuration
	range	A range of Ipv4/Ipv6 multicast addresses for the profile
	<ipv4_mcast>	Valid Ipv4 multicast address
	<ipv6_mcast>	Valid Ipv6 multicast address
	<word16>	Profile name in 16 characters
	default	Set a command to its defaults
	description	Additional description about the profile in 64 characters
	do	To run exec commands in the configuration mode
	end	Go back to EXEC mode
	exit	Exit from current mode
	help	Description of the interactive help system
	no	Negate a command or set its defaults
	deny	Deny matching addresses
	permit	Permit matching addresses
	log	Log when matching
	next	Specify next entry used in profile. Default: Add entry last
	<word16>	Range entry name in 16 characters
	<cr>	

Example:

```

SISPM1040-3248-L(config-ipmc-profile)# ipmc profile test
SISPM1040-3166-L(config-ipmc-profile)# range IpmcProfR1 permit log next Range1
SISPM1040-3166-L(config-ipmc-profile)#
SISPM1040-3166-L(config)# ipmc profile IpmcProf-1
SISPM1040-3166-L(config-ipmc-profile)# ?
  default      Set a command to its defaults
  description  Additional description about the profile in 64 characters
  do           To run exec commands in the configuration mode
  end          Go back to EXEC mode
  exit         Exit from current mode
  help         Description of the interactive help system
  no           Negate a command or set its defaults
  range        A range of Ipv4/Ipv6 multicast addresses for the profile
SISPM1040-3166-L(config-ipmc-profile)#

```

Messages: % Invalid range name many.

Command: **ipv6**

Description: Ipv6 configuration commands.

Syntax:

```

ipv6 mld host-proxy [ leave-proxy ]
ipv6 mld snooping
ipv6 mld snooping vlan <v_vlan_list>
ipv6 mld ssm-range <v_ipv6_mcast> <ipv6_prefix_length>
ipv6 mld unknown-flooding
ipv6 route <v_ipv6_subnet> { <v_ipv6_ucast> | interface vlan <v_vlan_id> <v_ipv6_addr> }

```

Parameters:	mld	Multicast Listener Discovery
	route	Configure static routes
	host-proxy	MLD proxy configuration
	snooping	Snooping MLD
	ssm-range	Ipv6 address range of Source Specific Multicast
	unknown-flooding	Flooding unregistered Ipv6 multicast traffic
	leave-proxy	MLD proxy for leave configuration
	unknown-flooding	Flooding unregistered Ipv6 multicast traffic
	vlan	MLD VLAN
	<vlan_list>	VLAN identifier (VID)
	<ipv6_mcast>	Valid Ipv6 multicast address
	<ipv6_subnet>	Ipv6 prefix x:x::y/z
	<ipv6_ucast>	Ipv6 unicast address (except link-local address) of next-hop
	interface	Select an interface to configure
	vlan	VLAN Interface
	<vlan_id>	VLAN identifier (VID)
	<cr>	

Example:

```

SISPM1040-3248-L(config)# ipv6 mld unknown-flooding
SISPM1040-3248-L(config)# ipv6 mld host-proxy
SISPM1040-3248-L(config)# ipv6 mld snooping
SISPM1040-3248-L(config)# ipv6 mld snooping vlan 100
% 'ipv6 mld snooping vlan <xx>' is obsolete.
SISPM1040-3166-L(config)# ipv6 mld snooping vlan 100
SISPM1040-3166-L(config)# ipv6 route 2001:db8::/32 interface vlan 10 2001:db8::/33

```

Command: `json`

Description: Configure JavaScript Object Notation RPC. [JSON](#) is a lightweight data-interchange format that is easy for humans to read and write and easy for machines to parse and generate.

Syntax : `json notification host <hname>`
`json notification listen <notification> <host>`

Parameters:

host	Notification host
listen	JSON-RPC notification event subscription
<word32>	Name of Notification host
authentication	Authentication configuration
do	To run exec commands in the configuration mode
end	Go back to EXEC mode
exit	Exit from current mode
help	Description of the interactive help system
no	
url	URL of notification destination
basic	Basic authentication
username	Username
<word32>	Username
password	Password
<cr>	
<cword>	Valid words are 'acl.status.ace.crossedThreshold.update' 'aggregation.status.notification.update' 'arpInspection.status.crossedThreshold.update' 'ethernetLinkOam.statistics.interface.criticalLinkEvent.update' 'ip.status.acd.ipv4.update' 'ip.status.interface.dhcpClient.update' 'ip.status.interface.ipv4.update' 'ip.status.interface.ipv6.update' 'ip.status.interface.link.update' 'ip.status.route.ipv4.update' 'ip.status.route.ipv6.update' 'mep.status.instance.update' 'mep.status.instancePeer.update' 'mep.status.lmHli.update' 'mep.status.lmNotif.update' 'port.status.update' 'portSecurity.status.global.notification.update' 'portSecurity.status.interface.notification.update' 'qos.status.global.update'

Example:

```
SISPM1040-3248-L(config)# json notification listen ip.status.acd.ipv4.update server
SISPM1040-3248-L(config)# json notification host mav
SISPM1040-3248-L(config-json-noti-host)# authentication basic username bob
SISPM1040-3248-L(config-json-noti-host)# authentication basic username bob password admin
SISPM1040-3248-L(config-json-noti-host)#
```

Messages: % Failed to create json notification host: mav
 % (DESTINATION_DOES_NOT_EXISTS)

Command: **lACP**

Description: Configure LACP settings. Link Aggregation Control Protocol (LACP) is an IEEE 802.3ad standard protocol that allows bundling several physical ports together to form a single logical port.

Syntax: **lACP** system-priority <v_1_to_65535>

Parameters: system-priority System priority
<1-65535> Priority value, lower means higher priority.

Example:

```
SISPM1040-3248-L(config)# lACP system-priority 5000
SISPM1040-3248-L(config)#
```

Command: **line**

Description: Configure a terminal line.

Syntax:

```
do <command>
editing
end
exec-banner
exec-timeout <min> [ <sec> ]
exit
help
history size <history_size>
length <length>
location <location>
motd-banner
no editing
no exec-banner
no exec-timeout
no history size
no length
no location
no motd-banner
no privilege level
no width
privilege level <privileged_level>
width <width>
```

Parameters:

<0~16>	List of line numbers
console	Console terminal line
vty	Virtual terminal
do	To run exec commands in the configuration mode
editing	Enable command line editing
end	Go back to EXEC mode
exec-banner	Enable the display of the EXEC banner

exec-timeout	Set the EXEC timeout
exit	Exit from current mode
help	Description of the interactive help system
history	Control the command history function
length	Set number of lines on a screen
location	Enter terminal location description
motd-banner	Enable the display of the MOTD banner
no	Negate a command or set its defaults
privilege	Change privilege level for line
width	Set width of the display terminal
<0-1440>	Timeout in minutes
size	Set history buffer size
<0-32>	Number of history commands, 0 means disable
<0,3-512>	Number of lines on screen (0 for no pausing)
<0,40-512>	Number of characters on a screen line (0 for unlimited width)

Example:

```
SISPM1040-3248-L(config)# line vty 0
SISPM1040-3248-L(config-line)# ?
  do                To run exec commands in the configuration mode
  editing           Enable command line editing
  end               Go back to EXEC mode
  exec-banner       Enable the display of the EXEC banner
  exec-timeout      Set the EXEC timeout
  exit              Exit from current mode
  help              Description of the interactive help system
  history           Control the command history function
  length            Set number of lines on a screen
  location          Enter terminal location description
  motd-banner       Enable the display of the MOTD banner
  no                Negate a command or set its defaults
  privilege         Change privilege level for line
  width             Set width of the display terminal
SISPM1040-3248-L(config-line)# exec-timeout 1440
SISPM1040-3248-L(config-line)# history size 12
SISPM1040-3248-L(config-line)# exit
SISPM1040-3248-L(config)#
```

Command: **lldp**

Description: Configure Link Layer Discover Protocol.

Syntax:

lldp holdtime <val>**lldp** med datum { wgs84 | nad83-navd88 | nad83-mlw }**lldp** med fast <v_1_to_10>**lldp** med location-tlv altitude { meters | floors } <v_word11>**lldp** med location-tlv civic-addr { { country <country> } | { state | county | city | district | block | street | leading-street-direction | trailing-street-suffix | street-suffix | house-no | house-no-suffix | landmark | additional-info | name | zip-code | building | apartment | floor | room-number | place-type | postal-community-name | p-o-box | additional-code } <v_line> }**lldp** med location-tlv elin-addr <v_word25>**lldp** med location-tlv latitude { north | south } <v_word8>**lldp** med location-tlv longitude { west | east } <v_word9>**lldp** med media-vlan-policy <policy_index> { voice | voice-signaling | guest-voice-signaling | guest-voice | softphone-voice | video-conferencing | streaming-video | video-signaling } { untagged | tagged <v_vlan_id> [12-priority <v_0_to_7>] } [dscp <v_0_to_63>]**lldp** reinit <val>**lldp** timer <val>**lldp** transmission-delay <val>Parameters:

holdtime Sets LLDP hold time (The neighbor switch will discarded the LLDP information after 'hold time' multiplied with 'timer' seconds).

Med Media Endpoint Discovery.

Reinit LLDP tx reinitialization delay in seconds..

timer Sets LLDP TX interval (The time between each LLDP frame transmitted in seconds).

Transmission-delay Sets LLDP transmission-delay. LLDP transmission delay (the amount of time that the transmission of LLDP frames will delayed after LLDP configuration has changed) in seconds.)

<2-10> 2-10 seconds holdtime.

Datum Datum (geodetic system) type.

Fast Number of times to repeat LLDP frame transmission at fast start.

Location-tlv LLDP-MED Location Type Length Value parameter.

Media-vlan-policy Create a policy, which can be assigned to an interface.

<1-10> 1-10 seconds reinit.

<5-32768> 5-32768 seconds timer.

<1-8192> 1-8192 seconds delay.

Example:

```
SISPM1040-3248-L(config)# lldp holdtime 5
SISPM1040-3248-L(config)# lldp med fast 5
SISPM1040-3248-L(config)# lldp reinit 3
SISPM1040-3248-L(config)# lldp timer 555
SISPM1040-3248-L(config)# lldp transmission-delay 333
```

Note: According to IEEE 802.1AB-clause 10.5.4.2 the transmission-delay must not be larger than LLDP timer * 0.25. LLDP timer changed to 1332

```
SISPM1040-3248-L(config)#
```

Command: **logging**

Description: Configure System logging (SysLog) parameters.

Syntax: **logging** host { <ipv4_addr> | <domain_name> }
logging notification listen <name> level { informational | notice | warning | error } <node>
logging on
logging port <port_no>

Parameters:

host	host
notification	notification
on	Enable Switch logging host mode
port	Service port number
<domain_name>	A valid name consist of a sequence of domain labels separated by '.', each domain label starting and ending with an alphanumeric character and possibly also containing '-' characters. The length of a domain label must be 63 characters or less.
<ipv4_ucast>	The Ipv4 address of the log server
listen	listen
<keyword127>	A name identifying the listen command
<1-65535>	Port number
level	Severity level
error	Severity 3: Error conditions
informational	Severity 6: Informational messages
notice	Severity 5: Normal but significant condition
warning	Severity 4: Warning conditions
<line255>	Identification of the notification source

Example:

```
SISPM1040-3248-L(config)# logging host 192.168.1.30
SISPM1040-3248-L(config)# logging on
SISPM1040-3248-L(config)# logging notification listen Jslistener level warning NotSrc
Cannot create notification listen Jslistener NotSrc, NotSrc not found
SISPM1040-3248-L(config)#
```

Command: **loop-protect**

Description: Loop protection configuration.

Syntax: **loop-protect**
loop-protect shutdown-time <t>
loop-protect transmit-time <t>

Parameters:

shutdown-time Loop protection shutdown time interval
transmit-time Loop protection transmit time interval
<0-604800> Shutdown time in seconds
<1-10> Transmit time in seconds

Example:

```
SISPM1040-3248-L(config)# loop-protect
SISPM1040-3248-L(config)# loop-protect shutdown-time 333
SISPM1040-3248-L(config)# loop-protect transmit-time 3
SISPM1040-3248-L(config)#
```

Command: **mac**

Description: MAC table entries/configuration.

Syntax:

mac address-table aging-time <v_0_10_to_1000000>**mac** address-table learning vlan <vlan_list>**mac** address-table static <v_mac_addr> vlan <v_vlan_id> { [interface (<port_type> [<v_port_type_list>])] [sr <v_uint>] [psfp <v_uint_1>] }

Parameters:

address-table	MAC table entries/configuration
aging-time	Mac address aging time
learning	Mac Learning
static	Static MAC address
<0,10-1000000>	Aging time in seconds, 0 disables aging
<mac_addr>	48 bit MAC address: xx:xx:xx:xx:xx:xx
vlan	VLAN keyword
<vlan_id>	VLAN IDs 1-4094
interface	VLAN IDs 1-4095
*	All switches or All ports
GigabitEthernet	1 Gigabit Ethernet Port
10GigabitEthernet	10 Gigabit Ethernet Port
<port_type_list>	Port list in 1/1-28

Example:

```
SISPM1040-3248-L(config)# mac address-table learning vlan 100-200
SISPM1040-3248-L(config)# mac address-table aging-time 3333
SISPM1040-3248-L(config)# mac address-table learning vlan 4094
SISPM1040-3248-L(config)# mac address-table static 1a:22:33:44:55:66 vlan 1 interface
GigabitEthernet 1/12
SISPM1040-3248-L(config)#
```

Command: **map-api-key**

Description: Set Google Maps key string. To get the Google Maps API Key go to the Google developer's webpage at <https://developers.google.com/maps/documentation/directions/get-api-key>. Follow the on-screen instructions.

Syntax: **map-api-key** <key_str>

Parameters: <word127>

Example:

```
SISPM1040-3248-L(config)# map-api-key da76hj98
SISPM1040-3248-L(config)# do show map
Key   : da76hj98
SISPM1040-3248-L(config)#
```

Command: **mep**

Description: Configure Maintenance Entity Point.

Syntax:

```

mep <inst> [ mip ] { up | down } domain { port | evc | vlan | tp-link | tunnel-tp | pw | lsp } [ vid <vid> ] [ flow
<flow> ] level <level> [ interface <port_type> <port> ]
mep <inst> ais [ fr1s | fr1m ] [ protect ]
mep <inst> aps <prio> [ multi | uni ] { laps | { raps [ octet <octet> ] } }
mep <inst> cc <prio> [ fr300s | fr100s | fr10s | fr1s | fr6m | fr1m | fr6h ] [ rx-only ]
mep <inst> ccm-tlv
mep <inst> client domain { evc | vlan | lsp } flow <cflow> [ level <level> ] [ ais-prio [ <aisprio> | ais-highest ] ] [
lck-prio [ <lckprio> | lck-highest ] ]
mep <inst> dm <prio> [ multi | { uni mep-id <mepid> } ] [ single | dual ] [ rdtrp | flow ] interval <interval> last-n
<lastn>
mep <inst> dm bin fd <num_fd_var>
mep <inst> dm bin ifdv <num_ifdv_var>
mep <inst> dm bin threshold <threshold_var>
mep <inst> dm ns
mep <inst> dm overflow-reset
mep <inst> dm proprietary
mep <inst> dm synchronized
mep <inst> lb <prio> [ dei ] [ multi | { uni { { mep-id <mepid> } | { mac <mac> } } } | { mpls ttl <mpls_ttl> } ] count
<count> size <size> interval <interval>
mep <inst> lck [ fr1s | fr1m ]
mep <inst> level <level>
mep <inst> link-state-tracking
mep <inst> lm <prio> [ synthetic ] [ multi | { uni [ mep-id <mepid> ] } ] [ single | dual ] [ fr100s | fr10s | fr1s |
fr6m ] [ size <size> ] [ flr <flr> ] [ meas <meas> ] [ threshold <loss_th> ] [ slm-testid <slm_testid> ]
mep <inst> lm flow-counting
mep <inst> lm oam-counting { [ y1731 | all ] }
mep <inst> lm rx synthetic [ prio <prio> ] [ flr <flr> ] [ meas <meas> ] [ threshold <loss_th> ]
mep <inst> lm-avail interval <interval> flr-threshold <flr_th>
mep <inst> lm-avail maintenance
mep <inst> lm-hli flr-threshold <flr_th> interval <interval>
mep <inst> lm-notif los-int-cnt-holddown <los_int_cnt_holddown> los-th-cnt-holddown <los_th_cnt_holddown>
hli-cnt-holddown <hli_cnt_holddown>
mep <inst> lm-sdeg tx-min <tx_min> flr-threshold <flr_th> bad-threshold <bad_th> good-threshold <good_th>
mep <inst> lt <prio> { { mep-id <mepid> } | { mac <mac> } } ttl <tll>
mep <inst> meg-id <megid> { itu | itu-cc | { ieee [ name <name> ] } }
mep <inst> mep-id <mepid>
mep <inst> peer-mep-id <mepid> [ mac <mac> ]
mep <inst> performance-monitoring
mep <inst> syslog
mep <inst> tst <prio> [ dei ] mep-id <mepid> [ sequence ] [ all-zero | all-one | one-zero ] rate <rate> size <size>

```

mep <inst> tst rx
mep <inst> tst tx
mep <inst> vid <vid>

Parameters:

ais	Alarm Indication Signal
aps	Automatic Protection Switching protocol.
Cc	Continuity Check.
Ccm-tlv	The CCM TLV enable/disable
client	Client flow domain.
Dm	Delay Measurement.
Down	This MEP is a Down-MEP.
Lb	Loop Back.
Lck	Locked Signal.
Level	The MEG level of the MEP.
Link-state-tracking	Link State Tracking. When LST is enabled in an instance, Local SF or received 'isDown' in CCM Interface Status TLV, will bring down the residence port. Only valid in Up-MEP. The CCM rate must be 1 f/s or faster.
Lm	Loss Measurement. Either Service frame or Synthetic Frame LM.
Lm-avail	Availability for Loss Measurement
lm-hli	High Loss Interval for Loss Measurement
lm-notif	Loss Measurement JSON notifications
lm-sdeg	Signal Degrade for Loss Measurement
lt	Link Trace.
Meg-id	The ITU/IEEE MEG-ID.
Mep-id	The MEP ID.
Mip	This MEP instance is a half-MIP.
Peer-mep-id	The peer MEP ID.
Performance-monitoring	Performance monitoring Data Set collection (MEF35).
Syslog	Enable syslog.
Tst	Test Signal
up	This MEP is a Up-MEP.
Vid	The MEP VID.
Oui	Organizationally Unique Identified.
<0-0xFFFFF>	
sub-type	Sub-Type
<0-0xFF>	Sub-Type value – one octet.
Value	Value
<0-0xFF>	Value value – one octet
evc	EVC client flow.
Vlan	VLAN client flow.
Laps	Linear Automatic Protection Switching protocol.
Multi	OAM PDU is transmitted with multicast MAC. Must me 'multi' in case of RAPS.
Raps	Ring Automatic Protection Switching protocol.

Uni	OAM PDU is transmitted with unicast MAC. The MAC is taken from peer MEP MAC database. Only possible in case of LAPS.
<0-7>	Priority in case of tagged OAM. In the MPLS and EVC domain this is the COS-ID.
Flow-counting	Loss Measurement is counting service frames per flow – all priority in one.
Oam-counting	Loss Measurement is counting OAM frames either as Y1731 or all
rx	Receive and respond to LM PDUs from LM initiator.
<0-7>	Priority in case of tagged OAM. In the EVC domain this is the COS-ID.
Mac	Link Trace target unicast MAC to be used in case of LT against MIP.
Mep-id	Peer MEP ID for Link Trace target unicast MAC. The MAC is taken from peer MEP MAC database.
Flow	Client flow instance.
<uint>	Client flow instance number value.
Ais-prio	AIS injection priority.
Lck-prio	LCK injection priority.
Level	The MEG level on the client layer.
Ais-prio	AIS injection priority.
Lck-highest	Request the highest possible LCK priority.
Level	The MEG level on the client layer.
<0-7>	The MEG level value.
<cr>	

Example:

```
SISPM1040-3248-L(config)# mep 1 syslog
SISPM1040-3248-L(config)# do show mep

Oper = 'Up' -> The instance is UP meaning it is physically configured and operational
Oper = 'Down' -> The instance is DOWN meaning it is NOT physically configured and
operational
Oper = 'Config' -> The instance is DOWN due to invalid configuration
Oper = 'HW' -> The instance is DOWN due to failing OAM supporting HW resources
Oper = 'MCE' -> The instance is DOWN due to failing MCE resources

MEP state is:
  Inst  Oper  cLevel  cMeg  cMep  cAis  cLck  cLoop  cConf  cDeg  cSsf  aBlk  aTsd  aTsf  Peer
MEP  cLoc  cRdi  cPeriod  cPrio
  1    Up    False  False  False  False  False  False  False  False  True  False  False  True
  2    Config  False  False  False  False  False  False  False  False  False  False  False  False
SISPM1040-3166-L(config)# mep 1 lm flow-counting
SISPM1040-3166-L(config)# mep 1 lm oam-counting
SISPM1040-3166-L(config)#
SISPM1040-3248-L(config)# 66arame-tlv oui 8 sub-type 8 value 8
SISPM1040-3166-L(config)# mep 1 client domain vlan flow 1 level 4
SISPM1040-3166-L(config)#
```

Command: **monitor**

Description: Monitoring different system events.

Syntax: **monitor** session <session_number> [destination { interface (<port_type> [<di_list>]) } | source { interface (<port_type> [<si_list>]) [both | rx | tx] }]

Parameters:	<1-5>	MIRROR session number
	destination	MIRROR destination interface or VLAN
	source	MIRROR source interface, VLAN
	interface	MIRROR destination interface
	*	All switches or All ports
	GigabitEthernet	1 Gigabit Ethernet Port
	10GigabitEthernet	10 Gigabit Ethernet Port
	<port_type_list>	Port list in 1/1-28
	both	MIRROR source receive both
	rx	MIRROR source receive Rx
	tx	MIRROR source receive Tx
	vlan	MIRROR destination Remote number
	<vlan_id>	Remote MIRROR destination RMIRROR VLAN number
	reflector-port	Remote MIRROR reflector interface
	cpu	MIRROR source CPU
	interface	MIRROR source interface
	remote	MIRROR source Remote
	vlan	MIRROR source VLAN
	both	MIRROR source CPU receive both
	rx	MIRROR source CPU receive Rx
	tx	MIRROR source CPU receive Tx

Example:

```
SISPM1040-3248-L(config)# monitor session 1
SISPM1040-3248-L(config)# $session 1 source interface GigabitEthernet 1/8 tx
SISPM1040-3248-L(config)# $1 source interface GigabitEthernet 1/5 rx
SISPM1040-3248-L(config)# do show monitor
Session 1
-----
Mode                : Disabled
Type                : Mirror
Source VLAN(s)      :
   RX Only          : Gi 1/5
   TX Only          : Gi 1/8
Destination Ports   : Gi 1/4
CPU Port            :
Session 2
-----
-- more --, next page: Space, continue: g, quit: ^C
```

Messages: % The destination ports of Mirror session have reached the limit

Command: **mrp-ring**

Description: Media Redundancy Protocol Ring configuration. See [Appendix A – MRP Configuration](#) on page 247 for MRP Configuration information.

Syntax:

```

mrp-ring <domainId> client blocked-state { enable | disable }
mrp-ring <domainId> client link-interval <downInterval> <upInterval> [ <linkChangeCount> ]
mrp-ring <domainId> diag-clear
mrp-ring <domainId> manager link-change-react { enable | disable }
mrp-ring <domainId> manager media-redundancy { enable | disable }
mrp-ring <domainId> manager nonblocking-supported { enable | disable }
mrp-ring <domainId> manager priority <priority>
mrp-ring <domainId> manager test-interval <testInterval> [ <shortTestInterval> ]
mrp-ring <domainId> manager test-monitoring <count> [ <extendedCount> ]
mrp-ring <domainId> manager topology-change <topoChangeInterval> [ <topoChangeRepeatCount> ]
mrp-ring <domainId> name <domainName>
mrp-ring <domainId> ringport { primary | secondary } <port_type> <mrp_port>
mrp-ring <domainId> ringport-delete { primary | secondary }
mrp-ring <domainId> role { manager | client }
mrp-ring <domainId> status { enable | disable }
mrp-ring <domainId> uuid <domainUUID>
mrp-ring <domainId> vlan <vlanId>
mrp-ring domain delete <domainId>
mrp-ring domain new <domainId>

```

Parameters:

<1-2>	DomainID of Domain to modify
domain	Create/Delete MRP Domain
client	Operate on an MRP Client
diag-clear	Clear Diagnostic stats for MRP Domain
manager	Operate on an MRP Manager
name	Set name for Domain
ringport	Set/Add Ringport
ringport-delete	Delete Ringport
role	Set role in Domain to manager or client
status	Enable/Disable a domain
uuid	Set UUID for Domain
vlan	Set VLAN for Domain
delete	Delete an MRP Domain
new	Create a new MRP Domain
blocked-state	Enable/Disable Blocked State support for MRP Client
link-interval	Set Client Link Intervals and Count for MRP Client
disable	Disable Client Blocked State support
enable	Enable Client Blocked State support (default)

<1-50>	Client Link Down Interval in ms (default=20)
link-change-react	Enable/Disable Manager Link Change Reaction
media-redundancy	Enable/Disable Manager Media Redundancy Mode (MRM)
nonblocking-supported	Enable/Disable Manager Non-blocking support
priority	Set Manager Priority
test-interval	Set Manager Test Intervals
test-monitoring	Set Manager Test Monitoring values
topology-change	Set Manager Topology Change settings
disable	Disable Manager link change reaction (default)
enable	Enable Manager link change reaction
<word32>	Updated Domain name
primary	Set primary Ringport
secondary	Set secondary Ringport
GigabitEthernet	1 Gigabit Ethernet Port
10GigabitEthernet	10 Gigabit Ethernet Port
<port_type_id>	Port ID in 1/1-4
primary	Delete the primary Ringport
secondary	Delete the secondary Ringport
client	Set role in Domain to client
manager	Set role in Domain to manager
disable	Disable Domain
enable	Enable Domain
<word64>	Updated Domain UUID
<0-4094>	VLAN ID to apply to Domain (VLAN 0 means disable vlan)
<1-2>	Domain ID of new Domain
<1-50>	Client Link Up Interval in ms (default=20)
<1-10>	Client Link Change Count (default=4)
<0-15>	New Manager Priority (0 is highest, default=8)
disable	Disable Manager Monitor mode
enable	Enable Manager Monitor mode (default)
disable	Disable Manager Non-blocking support (default)
enable	Enable Manager Non-blocking support
<1-50>	New Manager Test Interval in ms (default=20)
<1-15>	Set Manager Test Monitoring Count (default=3)
<1-20>	New Manager Topology Change Interval in ms (default=10)
<1-5>	New Manager Topology Change Repeat Count (default=3)

Example:

```
SISPM1040-3248-L(config)# mrp-ring domain new 1
SISPM1040-3248-L(config)# mrp-ring 1 client link-interval 20 20 5
SISPM1040-3248-L(config)# mrp-ring 1 client blocked-state enable
SISPM1040-3248-L(config)# mrp-ring 1 manager priority 0
SISPM1040-3248-L(config)# mrp-ring 1 manager topology-change 12 2
SISPM1040-3248-L(config)#
```

MRP Messages:

W mrp_ring 247/mrp_ikli_client_link_interval#486: Warning: MRP Client Link Change Count: unable to modify domain with Id 1, Invalid parameter

W mrp_ring 248/mrp_ikli_domain_delete#192: Warning: MRP Domain Delete: unable to delete domain with Id 2, Domain is enabled

Command: **mvr**

Description: Multicast VLAN Registration configuration.

Syntax: **mvr** name <mvr_name> channel <profile_name>
mvr name <mvr_name> frame priority <cos_priority>
mvr name <mvr_name> frame tagged
mvr name <mvr_name> last-member-query-interval <ipmc_lmqi>
mvr name <mvr_name> mode { dynamic | compatible }
mvr name <mvr_name> { election | igmp-address <v_ipv4_ucast> }
mvr vlan <v_vlan_list> [name <mvr_name>]
mvr vlan <v_vlan_list> channel <profile_name>
mvr vlan <v_vlan_list> frame priority <cos_priority>
mvr vlan <v_vlan_list> frame tagged
mvr vlan <v_vlan_list> last-member-query-interval <ipmc_lmqi>
mvr vlan <v_vlan_list> mode { dynamic | compatible }
mvr vlan <v_vlan_list> { election | igmp-address <v_ipv4_ucast> }

Parameters:

name	MVR multicast name
vlan	MVR multicast VLAN
<word16>	MVR multicast VLAN name
channel	MVR channel configuration
election	Act as an IGMP Querier to join Querier-Election
frame	MVR control frame in TX
igmp-address	MVR address configuration used in IGMP
last-member-query-interval	Last Member Query Interval in tenths of seconds
mode	MVR mode of operation
name	MVR multicast name
<word16>	Profile name in 16 characters
priority	Interface CoS priority
tagged	Tagged IGMP/MLD frames will be sent
<0-7>	CoS priority ranges from 0 to 7
<ipv4_ucast>	A valid Ipv4 unicast address
<0-31744>	0 – 31744 tenths of seconds
compatible	Compatible MVR operation mode
dynamic	Dynamic MVR operation mode

Example:

```
SISPM1040-3248-L(config)# mvr
SISPM1040-3248-L(config)# mvr vlan 10 mode dynamic
```

```
SISPM1040-3248-L(config)# mvr name mMCBobB frame tagged
SISPM1040-3248-L(config)#
```

MVR Messages:

% Invalid operation.

% Failed to set MVR interface channel.

Command: **mvrp**

Description: Enable Multicast VLAN Registration Protocol feature globally and configure MVRP managed VLANs.

Syntax: **mvrp**

mvrp managed vlan { all | none | [add | remove | except] <vlist> }

Parameters:	managed	Set list of MVRP-managed VLANs
	vlan	Set managed VLANs of MVRP
	<vlan_list>	VLAN IDs of the managed VLANs of MVRP
	add	Add VLANs to the current list
	all	All VLANs
	except	All VLANs except the following
	none	No VLANs
	remove	Remove VLANs from the current list

Example:

```
SISPM1040-3248-L(config)# mvrp
SISPM1040-3248-L(config)# mvrp managed vlan add 10
SISPM1040-3248-L(config)# mvrp managed vlan all
SISPM1040-3248-L(config)#
```

Messages:

%% Failed to enable the MVRP feature globally.

% (Another MRP/GARP application is currently enabled – disable it first)

No commands

no Commands (Exec mode)

Command:

Description: Negate a command or set its defaults from Exec mode.

Syntax: **no** debug gdbserver
no debug interrupt monitor [source <intr_name>]
no debug ipv6 nd
no debug ptp ms-pdv log-level
no debug trace hunt
no port-security shutdown [interface (<port_type> [<v_port_type_list>])]
no ptp <clockinst> wireless mode interface (<port_type> [<v_port_type_list>])
no terminal editing
no terminal exec-timeout
no terminal history size
no terminal length
no terminal width

Parameters:	debug	Debugging functions
	port-security	Port Security
	ptp	Misc non persistent 1588 settings.
	Terminal	Set terminal line parameters
	gdbserver	
	interrupt	Application-handled interrupt source
	ipv6	Ipv6 configuration commands
	ptp	
	trace	
		Output modifiers
	monitor	Print a line on the console every time the corresponding source interrupt fires.
	Nd	Ipv6 Neighbor Discovery debugging
	ms-pdv	
	log-level	
	<0-3>	Clock instance [0-3]
	wireless	Enable wireless mode for one or more interfaces.
	Mode	Enable wireless mode for an interface.
	Interface	Interface
	*	All switches or All ports
	GigabitEthernet	1 Gigabit Ethernet Port
	10GigabitEthernet	10 Gigabit Ethernet Port
	editing	Enable command line editing
	exec-timeout	Set the EXEC timeout
	history	Control the command history function

length	Set number of lines on a screen
width	Set width of the display terminal

Example:

```
SISPM1040-3248-L# no debug??
No debug gdbserver
no debug interrupt monitor [ source <intr_name> ]
no debug ipv6 nd
no debug ptp ms-pdv log-level
no debug trace hunt
no port-security shutdown [ interface ( <port_type> [ <v_port_type_list> ] ) ]
no ptp <0-3> wireless
no debug trace hunt
SISPM1040-3166-L# no debug interrupt monitor source ?
<word> Valid words are 'AMS' 'CLK_ADJ' 'CLK_TSTAMP' 'EGR_ENGINE_ERR'
'EGR_FIFO_OVERFLOW' 'EGR_RW_FCS_ERR' 'EGR_TIMESTAMP_CAPTURED'
'EXT_1_SYNC' 'EXT_SYNC' 'FLNK' 'INGR_ENGINE_ERR'
'INGR_RW_FCS_ERR' 'INGR_RW_PREAM_ERR' 'LOS' 'PTP_PIN_0'
'PTP_PIN_1' 'PTP_PIN_2' 'PTP_PIN_3' 'PUSH_BUTTON' 'SYNC' 'VOE'
SISPM1040-3166-L# no debug ipv6 nd?
Nd Ipv6 Neighbor Discovery debugging
<cr>
SISPM1040-3166-L# no debug ptp ms-pdv log-level?
Log-level
<cr>
SISPM1040-3166-L#
```

no Commands (Config mode)

aaa	access	access-list	aggregation
always-on-poe	banner	clock	debug
dot1x	enable	eps	erps
evc	green-ethernet	gvrp	hostname
hqos	interface	ip	ipmc
ipv6	json	lacp	lldp
logging	loop-protect	mac	map-api-key
mep	monitor	mvr	mvrp
ntp	perf-mon	poe	port-security
privilege	prompt	ptp	qos
radius-server	rfc2544	rmon	sflow
snmp-server	spanning-tree	svl	switchport
system	tacacs-server	traffic-test-loop	udld
upnp	username	vlan	voice
web	y1564		

Command: no

Description: Negate a command or set its defaults from Config mode.

Syntax: Many; enter the command **no??** to display them all. See the related Config mode command for parameters.

Parameters: Many; enter the command **no ?** to display them all. See the related Config mode command for parameters.

Example:

```
SISPM1040-3248-L(config)# no svl fid 10
SISPM1040-3248-L(config)# no aaa authentication login telnet
SISPM1040-3166-L(config)# no voice vlan
SISPM1040-3166-L(config)#
```

no Commands (Interface Config mode)

access-list	aggregation	debug
description	dot1x	duplex
evc	excessive-restart	flowcontrol
frame-length-check	green-ethernet	gvrp
ip	ipv6	lacp
link-oam	lldp	loop-protect
mac	media-type	mrp
mtu	mvr	mvrp
poe	port-security	priority-flowcontrol
ptp	pvlan	qos
rmon	sflow	shutdown
spanning-tree	speed	switchport
udld		

Command: **no**

Description: Negate a command or set its defaults from Interface Config mode.

Syntax: Many; enter the command **no??** to display them all. See the related Config mode command for parameters.Parameters: Many; enter the command **no ?** to display them all. See the related Config mode command for parameters.

Example:

```
SISPM1040-3248-L(config-if)# no udld port
SISPM1040-3248-L(config-if)# no shutdown
SISPM1040-3248-L(config-if)# no mvrp
SISPM1040-3248-L(config-if)#
```

Command: **ntp**

Description: Configure NTP (Network Timing Protocol).

Syntax: **ntp**

ntp interval <interval>

ntp server <index_var> ip-address { <ipv4_var> | <ipv6_var> | <name_var> }

Parameters:	interval	Configure NTP Time-Sync Interval
	server	Configure NTP server
	<interval>	<5,10,15,30,60,120>
	<5,10,15,30,60,120>	interval setting in seconds
	<1-5>	index number
	ip-address	IP address
	<domain_name>	Domain name
	<ipv4_ucast>	Ipv4 address
	<ipv6_ucast>	Ipv6 address
	<cr>	

Example:

```
SISPM1040-3248-L(config)# ntp
SISPM1040-3248-L(config)# ntp server 1 ip-address 192.168.1.30
SISPM1040-3166-L(config)# ntp interval 15
SISPM1040-3166-L(config)#
  <1-5>  index number
SISPM1040-3166-L(config)# ntp server 1 ?
  ip-address  IP address
SISPM1040-3166-L(config)# ntp server 1 ip-address ?
  <domain_name>  Domain name
  <ipv4_ucast>   Ipv4 address
  <ipv6_ucast>   Ipv6 address
SISPM1040-3166-L(config)# ntp server 1 ip-address bob
SISPM1040-3166-L(config)#
```

Command: **non-stop-poe**

Description: Enable Non-Stop PoE operation. Replaced by the “always-on-poe” command at FW v8.40.1936.

Syntax: **non-stop-poe** <cr>

Parameters: | Output modifiers
begin Begin with the line that matches
exclude Exclude lines that match
include Include lines that match
<cr>

Example:

```
SISPM1040-3248-L(config)# non-stop-poe
Non-Stop-PoE Status : Enable
SISPM1040-3248-L(config)# no non-stop-poe
Non-Stop-PoE Status : Disable
SISPM1040-3248-L(config)#

SISPM1040-3248-L# show non-stop-poe
Non-Stop-PoE Status : Disable
SISPM1040-3248-L#
```

Command: **percepixon**

Description: Percepixon configuration. Enter Percepixon configuration mode and set Percepixon parameters. Percepixon is Lantronix cloud-hosted or on-premise management platform that provides a single pane of glass for centralized management and automated monitoring of deployed Lantronix products. For more information see www.lantronix.com/percepixon/. Percepixon was added at FW v8.50.0149.

Lantronix Provisioning Manager (LPM) is a software application that provisions, configures and updates Lantronix devices for local site installations and deployments. LPM discovery is enabled by default and is not configurable. For more LPM information see the [LPM product page](#).

Syntax:

```

active connection connection <number>
apply configuration updates disable
apply configuration updates enable
apply firmware updates disable
apply firmware updates enable
connection <con> connect to cloud
connection <con> connect to on premise
connection <con> host <host_name>
connection <con> port <number>
connection <con> secure port disable
connection <con> secure port enable
connection <con> validate certificates disable
connection <con> validate certificates enable
content check interval <hours>
device description <device_desp>
device id <device_id>
device key <device_key>
device name <device_name>
do <command>
end
exit
help
no device description
no device id
no device key
no device name
show
show connection <con>
show statistics
state disable
state enable
status update interval <minutes>

```

Parameters:

active	Sets active connection to Connection <number>
apply	Sets the mode on firmware updates
connection	Sets the connection 1 or connection 2
content	Sets the firmware and configuration check interval
device	Sets the Device ID
do	To run exec commands in the configuration mode
end	Go back to EXEC mode

exit	Exit from current mode
help	Description of the interactive help system
no	Removes
show	Displays the current configuration
state	Consoleflow state
status	Sets the status update interval
connection	Sets active connection to Connection <number>
configuration	Sets the action on configuration updates
firmware	Sets the mode on firmware updates
updates	Sets the action on configuration updates
disable	Sets the action on configuration updates to disable
enable	Sets the action on configuration updates to enable
updates	Sets the mode on firmware updates
disable	Restores the default action on new firmware (do not apply)
enable	Automatically apply new firmware
connect	Sets the mode to connect
host	Sets the Hostname or IP address of PercepXion
port	Sets the Port of PercepXion
secure	Sets the mode on HTTPS
validate	Sets the mode on certificate validation
to	Sets the mode to connect
cloud	Sets the cloud mode to connect
on	Sets the on premise mode to connect
premise	Sets the on premise mode to connect
check	Sets the firmware and configuration check interval
interval	Sets the firmware and configuration check interval
<1-56160>	Sets the firmware and configuration check interval
description	Sets the Device Description
id	Sets the Device ID
key	Sets the Device Key
name	Sets the Device Name
<word256>	Sets the Device Description
<word32>	Sets the Device ID
<word32>	Sets the Device Key
<word256>	Sets the Device Name
<word256>	Sets the Device Description
device	Removes
description	Removes the Device Description
id	Removes the Device ID
key	Removes the Device Key
name	Removes the Device Name
connection	Shows the connection 1 or connection 2
statistics	Displays the PercepXion statistics
<1-2>	Shows the connection 1 or connection 2
disable	Disables the PercepXion client
enable	Enables the PercepXion client
update	Sets the status update interval
interval	Sets the status update interval
<1-1440>	Sets the status update interval

Example:

```

SISPM1040-3248-L(config-percepXion)# active connection connection 1
SISPM1040-3248-L(config-percepXion)# apply configuration updates enable
SISPM1040-3248-L(config-percepXion)# apply configuration updates disable
SISPM1040-3248-L(config-percepXion)# apply firmware updates enable
SISPM1040-3248-L(config-percepXion)# connection 1 connect to cloud
SISPM1040-3248-L(config-percepXion)# connection 1 connect to on premise
SISPM1040-3248-L(config-percepXion)# content check interval 1000
SISPM1040-3248-L(config-percepXion)# device description Lantronix_3248-L
SISPM1040-3248-L(config-percepXion)# device id *****
SISPM1040-3248-L(config-percepXion)# device key #####
SISPM1040-3248-L(config-percepXion)# device name SispM1040-3248-1 Lantronix
                                                                    ^
% Invalid word detected at '^' marker.

SISPM1040-3248-L(config-percepXion)# device name SispM1040-3248-1
SISPM1040-3248-L(config-percepXion)# do show version brief
Version      : SISPM1040-3248-L (standalone) v8.50.0149
Build Date   : 2024-04-15T17:46:02+08:00
SISPM1040-3248-L(config-percepXion)# end

SISPM1040-3248-L# con t
SISPM1040-3248-L(config)# percepXion
SISPM1040-3248-L(config-percepXion)# exit
SISPM1040-3248-L(config)# percepXion
SISPM1040-3248-L(config-percepXion)# no device name
SISPM1040-3248-L(config-percepXion)# show connection 1
PercepXion Connection 1 Configuration:
Connect To : On Premise
Host : percepXion.com
Port : 443
Secure Port : Enabled
Validate Certificates: Enabled

SISPM1040-3248-L(config-percepXion)# state disable
SISPM1040-3248-L(config-percepXion)# state enable
SISPM1040-3248-L(config-percepXion)# status update interval 500

SISPM1040-3248-L(config-percepXion)#

```

Command: **perf-mon**

Description: Configure Performance Monitor

Syntax: **perf-mon** interval { lm | dm | evc } <minutes_var>
perf-mon session [lm | dm | evc]
perf-mon storage [lm | dm | evc | dm-binning]
perf-mon transfer
perf-mon transfer fixed-offset <fixed_offset_var>
perf-mon transfer hour <hours_var>
perf-mon transfer incomplete
perf-mon transfer minute <minutes_var>
perf-mon transfer mode { all | new | fixed <number_of_fixed_var> }
perf-mon transfer random-offset <random_offset_var>
perf-mon transfer url <url_var>

Parameters:	interval	Measurement Interval
	session	Session Enabled
	storage	Storage Enabled
	transfer	Transfer Mode Enabled
	dm	Delay Measurement
	evc	EVC
	lm	Loss Measurement
	<1-60>	Number of minutes
	dm	Delay Measurement
	dm-binning	Delay Measurement Bins
	fixed-offset	Scheduled offset
	hour	Scheduled hours
	incomplete	Include intervals from previous incomplete transfers
	minute	Scheduled minutes
	mode	Interval mode
	random-offset	Random offset
	url	Server URL
	all	All available intervals
	fixed	Fixed number of intervals
	new	New intervals since last transfer
	<cr>	

Example:

```
SISPM1040-3248-L(config)# perf-mon interval dm 1
SISPM1040-3248-L(config)# perf-mon session evc
SISPM1040-3248-L(config)# perf-mon storage dm-binning
SISPM1040-3248-L(config)# perf-mon transfer mode new
SISPM1040-3248-L(config)#
```

Command: poe

Description: Configure Power Over Ethernet.

Syntax:

```

poe capacitor-detection <cr>
poe management mode { class-consumption | class-reserved-power | allocation-consumption | allocation-
reserved-power | lldp-consumption | lldp-reserved-power }
poe ping-check { enable | disable }
poe profile id <id> name <entry_name>
poe profile id <id> { [ Sun <hour_v00_0_to_23> <min_v00_0_to_55> <hour_v01_0_to_23>
<min_v01_0_to_55> ] [ Mon <hour_v10_0_to_23> <min_v10_0_to_55> <hour_v11_0_to_23>
<min_v11_0_to_55> ] [ Tue <hour_v20_0_to_23> <min_v20_0_to_55> <hour_v21_0_to_23>
<min_v21_0_to_55> ] [ Wed <hour_v30_0_to_23> <min_v30_0_to_55> <hour_v31_0_to_23>
<min_v31_0_to_55> ] [ Thr <hour_v40_0_to_23> <min_v40_0_to_55> <hour_v41_0_to_23>
<min_v41_0_to_55> ] [ Fri <hour_v50_0_to_23> <min_v50_0_to_55> <hour_v51_0_to_23>
<min_v51_0_to_55> ] [ Sat <hour_v60_0_to_23> <min_v60_0_to_55> <hour_v61_0_to_23>
<min_v61_0_to_55> ] }
poe reboot-chip mode { enable | disable }
poe reboot-chip { [ Sun <hour_v00_0_to_23> <min_v00_0_to_55> ] [ Mon <hour_v10_0_to_23>
<min_v10_0_to_55> ] [ Tue <hour_v20_0_to_23> <min_v20_0_to_55> ] [ Wed <hour_v30_0_to_23>
<min_v30_0_to_55> ] [ Thr <hour_v40_0_to_23> <min_v40_0_to_55> ] [ Fri <hour_v50_0_to_23>
<min_v50_0_to_55> ] [ Sat <hour_v60_0_to_23> <min_v60_0_to_55> ] }

```

Parameters:

capacitor-detection	PoE legacy mode on
management	Use management mode to configure PoE power management method.
Ping-check	Enable/Disable POE Ping Check.
Profile	poe scheduling profile
reboot-chip	poe schedules to reboot PoE chip
mode	PoE Power Management Mode
allocation-consumption	Max. port power determined by allocated, and power is managed according to power consumption.
Allocation-reserved-power	Max. port power determined by allocated, and power is managed according to reserved power.
Class-consumption	Max. port power determined by class, and power is managed according to power consumption.
Class-reserved-power	Max. port power determined by class, and power is managed according to reserved power.
Lldp-consumption	Max. port power determined by LLDP Media protocol, and power is managed according to power consumption.
Lldp-reserved-power	Max. port power determined by LLDP Media protocol, and power is managed according to reserved power.
Disable	Disable POE Ping Check.
Enable	Enable POE Ping Check.

Id	poE scheduling profile id
<1-16>	poE scheduling profile id, from 1 to 16
Fri	Configure PoE Power scheduling on Friday
Mon	Configure PoE Power scheduling on Monday
Sat	Configure PoE Power scheduling on Saturday
Sun	Configure PoE Power scheduling on Sunday
Thr	Configure PoE Power scheduling on Thursday
Tue	Configure PoE Power scheduling on Tuesday
Wed	Configure PoE Power scheduling on Wednesday
name	poE scheduling profile name, the name length is 32
<0-23>	starting hour
<0-55>	start minute, value must be multiples of 5
<0-23>	end hour
<0-55>	end minute, value must be multiples of 5
Fri	Configure PoE Reboot scheduling on Friday
Mon	Configure PoE Reboot scheduling on Monday
Sat	Configure PoE Reboot scheduling on Saturday
Sun	Configure PoE Reboot scheduling on Sunday
Thr	Configure PoE Reboot scheduling on Thursday
Tue	Configure PoE Reboot scheduling on Tuesday
Wed	Configure PoE Reboot scheduling on Wednesday
mode	Configure poE reboot mode
<cr>	

Example 1:

```
SISPM1040-3248-L(config)# poe ping-check enable
SISPM1040-3248-L(config)# poe ping-check disable
SISPM1040-3248-L(config)# poe profile id 1 Fri 10 30 12 30
SISPM1040-3248-L(config)# poe management mode class-consumption
SISPM1040-3248-L(config)#
```

Example 2:

```
SISPM1040-3166-L(config)# poe capacitor-detection
SISPM1040-3166-L(config)# poe ping-check enable
SISPM1040-3166-L(config)# poe profile id 1 Sat 12 55 1 0
SISPM1040-3166-L(config)# poe profile id 1 name Pprof1
SISPM1040-3166-L(config)# poe reboot-chip mode enable
SISPM1040-3166-L(config)# poe reboot-chip Sun 12 30
SISPM1040-3166-L(config)#
```

Command: `port-security`

Description: This command has changed. Note that there are also Interface Config mode commands for configuring Port Security.

Syntax: `port-security`
`port-security` aging
`port-security` aging time <aging_time>
`port-security` hold time <hold_time>

Parameters: aging Enable/disable port security aging.
 Hold Configure hold options
 time Time in seconds between check for activity on learned MAC addresses.
 <10-10000000> Hold time in seconds
 time Violating MAC addresses are held non-forwarding for this amount of seconds
 <cr>

Example:

```
SISPM1040-3248-L(config)# port-security aging time 50000
SISPM1040-3248-L(config)# port-security hold time 75000
SISPM1040-3248-L(config)#
```

WARNING: PORT-SECURITY COMMANDS HAVE CHANGED IN A NON-BACKWARD-COMPATIBLE WAY STARTING WITH THE 4.1.0 RELEASE!

- **Changes** to global configuration commands:
 - “(no) port-security” which used to globally disable/enable the feature is obsolete and prints this message instead. Enabling is handled per-interface.
 - “(no) port-security hold time” is a new command that allows for specifying a number of seconds that violating MAC addresses are kept in the forwarding database.
- **Changes** to interface configuration commands:
 - “port-security violation” used to take four different actions. Of these, “trap” and “trap-shutdown” are no longer valid. Instead, there is a new mode, “restrict”, that is similar to “protect” except that it keeps recording MAC addresses even after the limit is reached. Such violating MAC addresses are kept blocking in the forwarding database until the hold time expires. Traps can still be sent, and are enabled through the central SNMP trap system.
 - “port-security maximum-violation” is a new command that can limit the number of violating MAC addresses. Only used when violation mode is “restrict”.
- **Changes** to show commands:
 - “show port-security switch [interface <port-interface>]” is obsolete. Use “show port-security [interface <port-interface>]” instead.
 - “show port-security port [interface <port-interface>]” is obsolete. Use “show port-security address [interface <port-interface>]” instead.
 - The output of the two show commands has also changed.
- **New clear command:**
 - “clear port-security dynamic <a-lot-of-options>]” is a new command that lets you clear a specific Port Security-controlled MAC address, all on a port, or all on a given VLAN.

Command: **privilege**

Description: Configure Command privilege level parameters. Every command has a privilege level (0-15). Users can run a command if the session's privilege level is greater than or equal to the command's privilege level. The session's privilege level initially comes from the login account's privilege level, though it is possible to change the session's privilege level after logging in.

Privilege Level	Types of Commands at this Privilege Level
0	Display basic system information
13	Configure features except for login accounts, the authentication method sequence, multiple logins, and administrator and enable passwords.
15	Configure login accounts, the authentication method sequence, multiple logins, and administrator and enable passwords.

Syntax: **privilege** <mode_name> level <privilege> <cmd>

Parameters:

<word> Valid words are 'config-vlan' 'configure' 'dhcp-pool' 'diag' 'exec' 'if-vlan' 'interface' 'ipmc-profile' 'json-noti-host' 'line' 'llag' 'qos-map-egress' 'qos-map-ingress' 'rfc2544-profile' 'router-if' 'snmps-host' 'stp-aggr' 'y1564-profile'

level Set privilege level of command

<0-15> Privilege level

<line128> Initial valid words and literals of the command to modify, in 128 characters

<cr>

Example:

```
SISPM1040-3248-L(config)# privilege line level 5 line
SISPM1040-3248-L(config)#
```

Command: **prompt**

Description: Set prompt.

Syntax: **prompt** <word32>

Parameters: <word32> Up to 32 chars of prompt. Precede prompt variables with a percent sign (%). Prompt variables: %h = hostname, %% = percent sign, %s = space, %t = tab, %D = date, %T = time, %Z = date and time (like '%DT%T' but ensures atomicity in case of %T rollover).

Example:

```
SISPM1040-3248-L(config)# prompt %h
SISPM1040-3248-L(config)#
```

Command: **ptp**

Description: Configure Precision Time Protocol (1588).

Syntax:

ptp <clockinst> afi-announce**ptp** <clockinst> afi-sync**ptp** <clockinst> clk sync <threshold> ap <ap>**ptp** <clockinst> domain <domain>

ptp <clockinst> filter-type { aci-default | aci-freq-xo | aci-phase-xo | aci-freq-tcxo | aci-phase-tcxo | aci-freq-ocxo-s3e | aci-phase-ocxo-s3e | aci-bc-partial-on-path-freq | aci-bc-partial-on-path-phase | aci-bc-partial-on-path-phase-synce | aci-bc-full-on-path-freq | aci-bc-full-on-path-phase | aci-bc-full-on-path-phase-synce | aci-freq-accuracy-fdd | aci-freq-accuracy-xdsl | aci-elec-freq | aci-elec-phase | aci-phase-tcxo-q | aci-bc-full-on-path-phase-q | aci-phase-relaxed-c60w | aci-phase-relaxed-c150 | aci-phase-relaxed-c180 | aci-phase-relaxed-c240 | aci-bc-full-on-path-phase-beta | aci-phase-ocxo-s3e-r4-6-1 | aci-basic-phase | aci-basic-phase-synce | aci-basic-phase-low | aci-basic-phase-low-synce }

ptp <clockinst> localpriority <localpriority>**ptp** <clockinst> log <debug_mode> [log-to-file] [control] [max-time <max_time>]**ptp** <clockinst> log delete

ptp <clockinst> mode { boundary | e2etransparent | p2ptransparent | master | slave | bcfrentend } [onestep | twostep] [ethernet | ethernet-mixed | ip4multi | ip4mixed | ip4unicast | oam | onepps] [oneway | twoway] [id <v_clock_id>] [vid <vid> [<prio>]] [mep <mep_id>] [profile { ieee1588 | g8265.1 | g8275.1 | 802.1as }] [clock-domain <clock_domain>] [dscp <dscp_id>]

ptp <clockinst> path-trace-enable**ptp** <clockinst> priority1 <priority1>**ptp** <clockinst> priority2 <priority2>**ptp** <clockinst> servo displaystates

ptp <clockinst> slave-cfg [stable-offset <stable_offset>] [offset-ok <offset_ok>] [offset-fail <offset_fail>] [ok] [offset-fail <offset_fail>] leap-61] [time-traceable] [freq-traceable] [ptp-timescale] [time-source <time_source>] [leap-pending <date_string> { leap-59 | leap-61 }]

ptp <clockinst> uni <idx> [duration <duration>] <ip>**ptp** <clockinst> virtual-port accuracy <ptp_accuracy>**ptp** <clockinst> virtual-port class <ptp_class>**ptp** <clockinst> virtual-port io-pin <ptp_io_pin>**ptp** <clockinst> virtual-port local-priority <local_priority>**ptp** <clockinst> virtual-port priority1 <priority1>**ptp** <clockinst> virtual-port priority2 <priority2>**ptp** <clockinst> virtual-port variance <ptp_variance>**ptp** ext [output | input | out-in] [ext <clockfreq>] [ltc | single | independent | common | auto]**ptp** ho-spec [cat1 <cat1>] [cat2 <cat2>] [cat3 <cat3>]

ptp io-pin <io_pin> [pps-output | waveform-output | load | save] [domain <domain>] [freq <freq>] [{ interface <port_type> <v_port_type_id> }] ptp ref-clock { mhz125 | mhz156p25 | mhz250 }

ptp rs422 baudrate <baudrate> [parity { none | even | odd }] [wordlength <wordlength>] [stopbits <stopbits>] [flowctrl { none | rtscts }]

```
ptp rs422 { main-auto | main-man | sub | calib } [ pps-delay <pps_delay> ] { ser [ proto { polyt | zda | rmc } ] | {
pim interface <port_type> <v_port_type_id> } }
```

```
ptp system-time { get | set }
```

```
ptp tc-internal [ mode <mode> ]
```

Parameters:

<0-3>	Clock instance [0-3]
ext	Update the 1PPS and External clock output config and VCXO frequency rate adjustment option
ho-spec	Set the Holdover specification for G8275 PTP clocks
io-pin	Set or show input/output configuration
rs422	Set the RS422 clock configuration
system-time	Enable synchronization between PTP time and system time
tc-internal	0 = MODE_30BIT, 1 = MODE_32BIT, 2 = MODE_44BIT, 3 = MODE_48BIT
afi-announce	Enable PTP Announce automatic frame injection
afi-sync	Enable PTP Sync automatic frame injection
clk	Set PTP slave clock options
domain	Clock domain for PTP
filter-type	Set the filter-type used by PTP
localpriority	Local priority for G8275.1 BMC algorithm (1 is highest priority)
log	Set the PTP debug mode
mode	Enable a PTP instance
path-trace-enable	Enable path trace option (i.e. Add Path Trace to Announce messages)
priority1	Clock priority 1 for PTP BMC algorithm (0 is highest priority)
priority2	Clock priority 2 for PTP BMC algorithm (0 is highest priority)
servo	Set Servo parameters
slave-cfg	Set PTP clock Slave Configuration
time-property	Set time properties
uni	Set a Unicast Slave configuration entry
virtual-port	Set a virtual port
sync	Set PTP slave clock options to 'clock is SyncE locked'
<1-1000>	Threshold in ns for offset from master defines in offset increment/decrement mode
ap	Set the adjustment factor
<1-40>	[1..40] The offset increment/decrement adjustment factor
<0-127>	PTP domain: range = 0-127
filter-type	aci-basic-phase
filter-type	aci-basic-phase-low
filter-type	aci-basic-phase-low-synce
filter-type	aci-basic-phase-synce
filter-type	aci-bc-full-on-path-freq
cat1	Define cat1 time
cat2	Define cat2 time
cat3	Define cat3 time
<0-999999999>	cat2 time in seconds
auto	AUTO Select clock control, based on PTP profile and available hardware resources

ext Enable external clock frequency output
 input Enable 1PPS input
 ltc Select Local Time Counter (LTC) frequency control
 out-in Enable 1PPS output and input (Jaguar1 only)
 output Enable 1PPS output
 <0-3> Pin number
 domain Set domain assigned to this pin.
 Freq Set clock frequency in the waveform case
 interface Set PTP slave interface
 load Set input/output configuration to load. Done on next 1pps input.
 Pps-output Set input/output configuration to 1-pps output
 save Set input/output pin configuration to save. Done on next 1pps input.
 Waveform-output Set input/output configuration to waveform (clock) output
 <0-2> Domain number 0..2
 <1-25000000> Clock frequency in Hz
 GigabitEthernet 1 Gigabit Ethernet Port
 10GigabitEthernet 10 Gigabit Ethernet Port
 baudrate <9600,19200,38400,115200>
 calib RS422 clock in calibration mode
 main-auto RS422 clock in main-auto mode (1PPS out, save time at L/S input)
 main-man RS422 clock in main-man mode (1PPS out, send configured PPS delay to sub module)
 sub RS422 clock in sub mode (save time and load new time at L/S input)
 pim Use PIM protocol to transfer 1PPS information over a switch port
 pps-delay Set the 1PPS latency (used in main-man mode)
 ser Use Serial interface to transfer 1PPS information
 get Get (update) the PTP time from the system time
 set Set (update) the system time from the PTP time
 mode Set mode
 <0-3> 0 = MODE_30BIT, 1 = MODE_32BIT, 2 = MODE_44BIT, 3 = MODE_48BIT
 <1-25000000> [1..25.000.000] External Clock output frequency in Hz
 <cr>

Example:

```

SISPM1040-3248-L(config)# ptp system-time get
System clock synch mode (Get PTP time from System time)
SISPM1040-3248-L(config)# W ptp/ms_servo 17:02:48 190/vtss_ptp_update_selected_src#8216:
Warning: Could not change servo mode to 'packet mode'.
SISPM1040-3248-L(config)# ptp 0 servo displaystates
Error writing servo parameters, instance 0
SISPM1040-3166-L(config)# ptp ho-spec cat2 50000
SISPM1040-3166-L(config)# ptp ext ltc
SISPM1040-3166-L(config)# ptp io-pin 2 waveform-output
SISPM1040-3166-L(config)# ptp system-time set
System clock synch mode (Set System time from PTP time)
SISPM1040-3166-L(config)#
  
```

Command: qos

Description: Configure Quality of Service parameters.

Syntax:

```
qos map cos-dscp <cos> dpl <dpl> dscp { <dscp_num> | { be | af11 | af12 | af13 | af21 | af22 | af23 | af31 | af32 | af33 | af41 | af42 | af43 | cs1 | cs2 | cs3 | cs4 | cs5 | cs6 | cs7 | ef | va } }
```

```
qos map dscp-classify { <dscp_num> | { be | af11 | af12 | af13 | af21 | af22 | af23 | af31 | af32 | af33 | af41 | af42 | af43 | cs1 | cs2 | cs3 | cs4 | cs5 | cs6 | cs7 | ef | va } }
```

```
qos map dscp-cos { <dscp_num> | { be | af11 | af12 | af13 | af21 | af22 | af23 | af31 | af32 | af33 | af41 | af42 | af43 | cs1 | cs2 | cs3 | cs4 | cs5 | cs6 | cs7 | ef | va } } cos <cos> dpl <dpl>
```

```
qos map dscp-egress-translation { <dscp_num> | { be | af11 | af12 | af13 | af21 | af22 | af23 | af31 | af32 | af33 | af41 | af42 | af43 | cs1 | cs2 | cs3 | cs4 | cs5 | cs6 | cs7 | ef | va } } <dpl> to { <dscp_num_tr> | { be | af11 | af12 | af13 | af21 | af22 | af23 | af31 | af32 | af33 | af41 | af42 | af43 | cs1 | cs2 | cs3 | cs4 | cs5 | cs6 | cs7 | ef | va } }
```

```
qos map dscp-ingress-translation { <dscp_num> | { be | af11 | af12 | af13 | af21 | af22 | af23 | af31 | af32 | af33 | af41 | af42 | af43 | cs1 | cs2 | cs3 | cs4 | cs5 | cs6 | cs7 | ef | va } } to { <dscp_num_tr> | { be | af11 | af12 | af13 | af21 | af22 | af23 | af31 | af32 | af33 | af41 | af42 | af43 | cs1 | cs2 | cs3 | cs4 | cs5 | cs6 | cs7 | ef | va } }
```

```
qos map egress <map_id>
```

```
qos map ingress <map_id>
```

```
qos qce refresh
```

```
qos qce [ { update } ] <qce_id> [ { next <qce_id_next> } | last ] [ interface ( <port_type> [ <port_list> ] ) ] [ smac { <smac> | <smac_24> | any } ] [ dmac { <dmac> | unicast | multicast | broadcast | any } ] [ tag { { type { untagged | tagged | c-tagged | s-tagged | any } } [ vid { <ot_vid> | any } ] [ pcp { <ot_pcp> | any } ] [ dei { <ot_dei> | any } ] } *1 ] [ inner-tag { { type { untagged | tagged | c-tagged | s-tagged | any } } [ vid { <it_vid> | any } ] [ pcp { <it_pcp> | any } ] [ dei { <it_dei> | any } ] } *1 ] [ frame-type { any | { etype [ <etype_type> | any ] } } ] [ llc [ dsap { <llc_dsap> | any } ] [ ssap { <llc_ssap> | any } ] [ control { <llc_control> | any } ] ] [ { snap [ { <snap_data> | any } ] } ] [ { ipv4 [ proto { <pr4> | tcp | udp | any } ] [ sip { <sip4> | any } ] [ dip { <dip4> | any } ] [ dscp { <dscp4> | { be | af11 | af12 | af13 | af21 | af22 | af23 | af31 | af32 | af33 | af41 | af42 | af43 | cs1 | cs2 | cs3 | cs4 | cs5 | cs6 | cs7 | ef | va } | any } ] [ fragment { yes | no | any } ] [ sport { <sp4> | any } ] [ dport { <dp4> | any } ] ] | { ipv6 [ proto { <pr6> | tcp | udp | any } ] [ sip { <sip6> | any } ] [ dip { <dip6> | any } ] [ dscp { <dscp6> | { be | af11 | af12 | af13 | af21 | af22 | af23 | af31 | af32 | af33 | af41 | af42 | af43 | cs1 | cs2 | cs3 | cs4 | cs5 | cs6 | cs7 | ef | va } | any } ] [ sport { <sp6> | any } ] [ dport { <dp6> | any } ] ] } ] [ action [ { cos { <action_cos> | default } } [ dpl { <action_dpl> | default } ] [ pcp-dei { <action_pcp> <action_dei> | default } ] [ dscp { <action_dscp_dscp> | { be | af11 | af12 | af13 | af21 | af22 | af23 | af31 | af32 | af33 | af41 | af42 | af43 | cs1 | cs2 | cs3 | cs4 | cs5 | cs6 | cs7 | ef | va } | default } ] [ policy { <action_policy> | default } ] [ ingress-map { <action_ingress_map> | default } ] } ] *1 ]
```

```
qos storm { unicast | multicast | broadcast } <rate> [ fps | kfps | kbps | mbps ]
```

```
qos wred group <group> queue <queue> dpl <dpl> min-fl <min_fl> max <max> [ fill-level ]
```

Parameters:	map	Global QoS Map/Table
	qce	QoS Control Entry
	storm	Storm policer
	wred	Weighted Random Early Discard
	cos-dscp	Map for COS to DSCP
	dscp-classify	Map for DSCP classify enable
	dscp-cos	Map for DSCP to COS
	dscp-egress-translation	Map for DSCP egress translation
	dscp-ingress-translation	Map for DSCP ingress translation
	egress	Map for egress configuration
	ingress	Map for ingress configuration
	<0~7>	Specific class of service or range
	<0~63>	Specific DSCP or range
	af11	Assured Forwarding PHB AF11(DSCP 10)
	af12	Assured Forwarding PHB AF12(DSCP 12)
	af13	Assured Forwarding PHB AF13(DSCP 14)
	af21	Assured Forwarding PHB AF21(DSCP 18)
	af22	Assured Forwarding PHB AF22(DSCP 20)
	af23	Assured Forwarding PHB AF23(DSCP 22)
	af31	Assured Forwarding PHB AF31(DSCP 26)
	af32	Assured Forwarding PHB AF32(DSCP 28)
	af33	Assured Forwarding PHB AF33(DSCP 30)
	af41	Assured Forwarding PHB AF41(DSCP 34)
	af42	Assured Forwarding PHB AF42(DSCP 36)
	af43	Assured Forwarding PHB AF43(DSCP 38)
	be	Default PHB(DSCP 0) for best effort traffic
	cs1	Class Selector PHB CS1 precedence 1(DSCP 8)
	cs2	Class Selector PHB CS2 precedence 2(DSCP 16)
	cs3	Class Selector PHB CS3 precedence 3(DSCP 24)
	cs4	Class Selector PHB CS4 precedence 4(DSCP 32)
	cs5	Class Selector PHB CS5 precedence 5(DSCP 40)
	cs6	Class Selector PHB CS6 precedence 6(DSCP 48)
	cs7	Class Selector PHB CS7 precedence 7(DSCP 56)
	ef	Expedited Forwarding PHB(DSCP 46)
	va	Voice Admit PHB(DSCP 44)
	<0-511>	qos map egress Map ID
	<0-255>	qos map ingress Map ID
	<1-256>	QCE ID
	refresh	Refresh QCE tables in hardware
	update	Update an existing QCE
	action	Setup action
	dmac	Setup matched DMAC
	frame-type	Setup matched frame type

inner-tag	Setup inner tag options
interface	Interfaces
last	Place QCE at the end
next	Place QCE before the next QCE ID
smac	Setup matched SMAC
tag	Setup tag options
cos	Setup class of service action
dpl	Setup drop precedence level action
dscp	Setup DSCP action
ingress-map	Setup ingress map action
pcp-dei	Setup PCP and DEI action
policy	Setup ACL policy action
<mac_addr>	Matched DMAC (XX-XX-XX-XX-XX-XX)
any	Match any DMAC
broadcast	Match broadcast DMAC
multicast	Match multicast DMAC
unicast	Match unicast DMAC
any	Match any frame type
etype	Match EtherType frames
ipv4	Match Ipv4 frames
ipv6	Match Ipv6 frames
llc	Match LLC frames
snap	Match SNAP frames
dei	Setup matched DEI
pcp	Setup matched PCP
type	Setup matched tag type
vid	Setup matched VLAN ID
*	All switches or All ports
GigabitEthernet	1 Gigabit Ethernet Port
10GigabitEthernet	10 Gigabit Ethernet Port
<1-256>	QCE ID
broadcast	Police broadcast frames
multicast	Police multicast frames
unicast	Police unicast frames
<1-13128147>	Policer rate (default fps). Internally rounded up to the nearest value supported by the storm policer. Supported rates are divisible by 10 fps or 25 kbps.
Group	Specify WRED group
<1~3>	Specific group or range
queue	Specify queue
<0~7>	Specific queue or range
dpl	Specify DPL
<1~3>	Specific DPL or range

min-fl	Specify minimum fill level
<0-100>	Specific minimum fill level in percent
max	Specify maximum drop probability or fill level
fill-level	Specify fill level
<cr>	

Example:

```
SISPM1040-3248-L(config)# $ queue 0 dpl 1 min-fl 0 max 1 fill-level
SISPM1040-3248-L(config)# qos wred group 1 queue 0 dpl 1 min-fl 25 max 1
SISPM1040-3166-L(config)# qos map cos-dscp 4 dpl 2 dscp be
SISPM1040-3166-L(config)# qos qce 1 action cos 3 frame-type etype tag type c-tagged
SISPM1040-3166-L(config)# qos storm broadcast 50000 kfps
% QOS: max rate is 13128 when using kfps
SISPM1040-3166-L(config)# qos storm broadcast 13128 kfps
SISPM1040-3166-L(config)#
```

Command: radius-server

Description: Configure RADIUS for an interface.

Syntax: **radius-server** attribute 32 <id>
radius-server attribute 4 <ipv4>
radius-server attribute 95 <ipv6>
radius-server deadtime <minutes>
radius-server host <host_name> [auth-port <auth_port>] [acct-port <acct_port>] [timeout <seconds>] [retransmit <retries>] [key { [unencrypted] <unencrypted_key> | encrypted <encrypted_key> }]
radius-server key { [unencrypted] <unencrypted_key> | encrypted <encrypted_key> }
radius-server retransmit <retries>
radius-server timeout <seconds>

Parameters:

attribute	NAS attributes
deadtime	Time to stop using a RADIUS server that doesn't respond
host	Specify a RADIUS server
key	Set RADIUS encryption key
acct-port	UDP port for RADIUS accounting server
auth-port	UDP port for RADIUS authentication server
key	Server specific key (overrides default)
retransmit	Specify the number of retries to active server (overrides default)
timeout	Time to wait for this RADIUS server to reply (overrides default)
32	attribute number 32 = NAS-Identifier
4	attribute number 4 = NAS-IP-Address
95	attribute number 95 = NAS-Ipv6-Address
<1-1440>	Time in minutes
<word1-255>	Hostname or Ipv4/Ipv6 address

<word1-63>	The UNENCRYPTED (Plain Text) secret key. Notice that you have no chance to get the Plain Text secret key after this command. The system will always display the ENCRYPTED password.
Encrypted	Specifies an ENCRYPTED secret key will follow
unencrypted	Specifies an UNENCRYPTED secret key will follow
<1-1000>	Number of retries for a transaction
<1-1000>	Wait time in seconds
<cr>	

Example:

```

SISPM1040-3248-L(config)# radius-server attribute 32 Bob
SISPM1040-3248-L(config)# radius-server attribute 4 192.168.1.77
SISPM1040-3248-L(config)# radius-server deadtime 60
SISPM1040-3166-L(config)# radius-server host 192.168.1.30
SISPM1040-3166-L(config)# radius-server key unencrypted admin
SISPM1040-3166-L(config)# radius-server retransmit 350
SISPM1040-3166-L(config)# radius-server timeout 60
SISPM1040-3166-L(config)# do show radius
Global RADIUS Server Timeout      : 60 seconds
Global RADIUS Server Retransmit   : 350 times
Global RADIUS Server Deadtime     : 0 minutes
Global RADIUS Server Key          : 51164fc2a4b3e3299a83310b04180a552e76508a3e07
ec2c9f4601ab3b6d53e4728b783c52f94024a901f84cf92fc12afac86fe3f8e674bf7e573f603444
77a5
Global RADIUS Server Attribute 4  :
Global RADIUS Server Attribute 95 :
Global RADIUS Server Attribute 32 :
RADIUS Server #1:
  Host name   : 192.168.1.30
  Auth port   : 1812
  Acct port   : 1813
  Timeout     :
  Retransmit  :
  Key         :
SISPM1040-3166-L(config)#

```

Command: **rapid-ring**

Description: Set Rapid Ring configurations. Other ring technologies (e.g., STP) must be disabled.

Syntax: **rapid-ring** entry <entryindex> role disabled
rapid-ring entry <entryindex> role master
rapid-ring entry <entryindex> role member

Parameters: entry Set entry index
 <uint8> index
 role Set role value
 disabled role value disabled
 master role value master
 member role value member

Example:

```
SISPM1040-3248-L(config)# rapid-ring entry 1 role master
SISPM1040-3248-L(config)# rapid-ring entry 1 role member
SISPM1040-3248-L(config)# rapid-ring entry 1 role disabled
SISPM1040-3248-L(config)#
```

Messages:

R_RING_ICLI_system_set error in port 25, STP is enable

Command: **rfc2544**Description: Configure RFC2544 performance tests ~~for an interface~~.Syntax: **rfc2544** profile <profile_name>**rfc2544** rename profile <old_profile_name> <new_profile_name>Parameters:

profile	RFC2544 profile configuration
<word32>	Profile name up to 32 characters long
rename	Rename an existing profile
back-to-back	Enable back-to-back test and optionally set its parameters
description	Add a description to profile
dmac	Set the destination MAC address of all transmitted PDUs. This must be a non-zero unicast MAC address of the peer
do	To run exec commands in the configuration mode
dst-oam-aware	Remote end (DST) is Y.1731 OAM aware or not (no-form) Y.1731 OAM aware. This setting determines the type of Y.1731 OAM frames transmitted from this end.
Dwell-time	Controls the number of seconds that the execution pauses after each trial before reading counters and status from hardware
end	Go back to EXEC mode
exit	Exit from current mode
frame-loss	Enable frame-loss test and optionally set its parameters
frame-sizes	Select the frame sizes that the enabled tests will loop through
help	Description of the interactive help system
latency	Enable latency test and optionally set its parameters
meg-level	Set profile MEG level used in TST PDUs.
No	Negate a command or set its defaults
sequence-check	Enable (no-form disables) sequence number checking of looped TST PDUs
test-interface	Set the egress interface on which PDUs are transmitted
test-vlan	Create a VLAN Down-MEP. All PDUs will then be transmitted with a VLAN tag
throughput	Enable throughput test and optionally set its parameters
count	Set the number of trials (bursts)
duration	Set the duration of one trial
<mac_addr>	MAC address of peer.
<line128>	Profile description.
<line>	Exec Command
1-10	Dwell time measured in seconds
duration	Set the duration of one trial
rate	Set the minimum, maximum, and/or rate steps
1024	Enable testing with 1024-byte TST PDUs
128	Enable testing with 128-byte TST PDUs
1280	Enable testing with 1280-byte TST PDUs
1518	Enable testing with 1518-byte TST PDUs
2000	Enable testing with 2000-byte TST PDUs

256	Enable testing with 256-byte TST PDUs
512	Enable testing with 512-byte TST PDUs
64	Enable testing with 64-byte TST PDUs
9600	Enable testing with 9600-byte TST PDUs
allowed-loss	Set the maximum allowed TST PDU loss at which the test is considered successful
duration	Set the duration of one trial
interval	Interval between sending delay measurement frames
0-7	MEG level
GigabitEthernet	1 Gigabit Ethernet Port
10GigabitEthernet	10 Gigabit Ethernet Port
<port_type_id>	Port ID in 1/1-28
<vlan_id>	The VLAN ID used in transmitted PDUs
dei	Control the VLAN tag's DEI value
pcp	Control the VLAN tag's PCP value
<0-1>	The DEI value used in the VLAN tag in transmitted PDUs
pcp	Control the VLAN tag's PCP value
<0-7>	The PCP value used in the VLAN tag in transmitted PDUs
allowed-loss	Set the maximum allowed TST PDU loss at which the test is considered successful
duration	Set the duration of one trial
rate	Set the minimum, maximum, and/or rate steps
max	Set the maximum rate
min	Set the minimum rate
1-1800	Duration – in seconds – of one trial
allowed-loss	Set the maximum allowed TST PDU loss at which the test is considered successful
0-100	The maximum allowed loss in permille at which the test is considered successful

Example:

```

SISPM1040-3166-L(config)# rfc2544 ?
  profile    RFC2544 profile configuration
  rename     Rename an existing profile
SISPM1040-3166-L(config)# rfc2544 profile ?
  <word32>   Profile name up to 32 characters long
SISPM1040-3166-L(config)# rfc2544 profile NewProfile ?
  <cr>
SISPM1040-3166-L(config)# rfc2544 profile NewProfile
SISPM1040-3248-L(config-rfc2544-profile)# dst-oam-aware
SISPM1040-3248-L(config-rfc2544-profile)# meg-level 1
SISPM1040-3248-L(config-rfc2544-profile)# sequence-check
SISPM1040-3248-L(config-rfc2544-profile)# test-vlan 10 dei 1 pcp 3
SISPM1040-3248-L(config-rfc2544-profile)# throughput rate accuracy 250 duration 500 allowed-
loss 25
SISPM1040-3248-L(config-rfc2544-profile)#

SISPM1040-3166-L(config-rfc2544-profile)# back-to-back count 25 duration 500
SISPM1040-3166-L(config-rfc2544-profile)#

```

Command: rmon

Description: Configure Remote Monitoring.

Syntax:

```
rmon alarm <id> { ifInOctets | ifInUcastPkts | ifInNUcastPkts | ifInDiscards | ifInErrors | ifInUnknownProtos |
ifOutOctets | ifOutUcastPkts | ifOutNUcastPkts | ifOutDiscards | ifOutErrors } <ifIndex> <interval> { absolute |
delta } rising-threshold <rising_threshold> [ <rising_event_id> ] falling-threshold <falling_threshold> [
<falling_event_id> ] { [ rising | falling | both ] }
```

```
rmon event <id> [ log ] [ trap [ <community> ] ] { [ description <description> ] }
```

Parameters:

alarm	Configure an RMON alarm
event	Configure an RMON event
ifInDiscards	The number of inbound packets that are discarded even the packets are normal
ifInErrors	The number of inbound packets that contained errors preventing them from being deliverable to a higher-layer protocol
ifInNUcastPkts	The number of broadcast and multicast packets delivered to a higher-layer protocol
ifInOctets	The total number of octets received on the interface, including framing characters
ifInUcastPkts	The number of unicast packets delivered to a higher-layer protocol
ifInUnknownProtos	The number of the inbound packets that were discarded because of the unknown or unsupported protocol
ifOutDiscards	The number of outbound packets that are discarded event the packets is normal
ifOutErrors	The number of outbound packets that could not be transmitted because of errors
ifOutNUcastPkts	The number of broadcast and multicast packets that request to transmit
ifOutOctets	The number of octets transmitted out of the interface, including framing characters
ifOutUcastPkts	The number of unicast packets that request to transmit
<uint>	Interface index
<1-2147483647>	Sample interval
absolute	Test each sample directly
delta	Test delta between samples
rising-threshold	Configure the rising threshold
<-2147483648-2147483647>	rising threshold value
<0-65535>	Event to fire on rising threshold crossing
falling-threshold	Configure the falling threshold
<-2147483648-2147483647>	falling threshold value
<0-65535>	Event to fire on falling threshold crossing
both	Trigger alarm when the first value is larger than the rising threshold or less than the falling threshold (default)
falling	Trigger alarm when the first value is less than the falling threshold
rising	Trigger alarm when the first value is larger than the rising threshold
<word127>	OBSOLETE: SNMP community string
description	Specify a description of the event
log	Generate RMON log when the event fires
<cr>	

Example:

```
SISPM1040-3248-L(config)# $sing-threshold 0 falling-threshold -1000
SISPM1040-3248-L(config)# rmon event 1 trap
SISPM1040-3248-L(config)#

SISPM1040-3166-L(config)# rmon alarm 1 ifInOctets 1 5000 absolute rising-threshold 0 1
falling-threshold -88888
SISPM1040-3166-L(config)#
```

Messages: % Invalid: rising threshold must be larger than falling threshold

Command: router

Description: Configure Routing process for Open Shortest Path First (OSPF).

Syntax: router ospf <cr>

Parameters:	ospf	Open Shortest Path First (OSPF)
	do	To run exec commands in the configuration mode
	end	Go back to EXEC mode
	exit	Exit from current mode
	help	Description of the interactive help system

Example:

```
SISPM1040-3166-L(config)# router?
Router ospf
SISPM1040-3166-L(config)# router ?
  ospf  Open Shortest Path First (OSPF)
SISPM1040-3166-L(config)# router ospf ?
  <cr>
SISPM1040-3166-L(config)# router ospf
SISPM1040-3248-L(config-router)# do show ip route
Codes: C - connected, S - static, O - OSPF,
       * - selected route, D - DHCP installed route

S* 0.0.0.0/0 [1/0] via 192.168.1.254, VLAN 1
C* 169.254.0.0/16 is directly connected, VLAN 1
C* 192.168.1.0/24 is directly connected, VLAN 1
SISPM1040-3248-L(config-router)#
SISPM1040-3166-L(config-router)# exit
SISPM1040-3166-L(config)#
```

Command: **sflow**

Description: Configure Statistics flow.

Syntax: **sflow** agent-ip { ipv4 <v_ipv4_addr> | ipv6 <v_ipv6_addr> }
sflow collector-address [receiver <rcvr_idx_list>] [<ipv4_var> | <ipv6_var> | <domain_name>]
sflow collector-port [receiver <rcvr_idx_list>] <collector_port>
sflow max-datagram-size [receiver <rcvr_idx_list>] <datagram_size>
sflow mode [receiver <rcvr_idx_list>] { enable | disable }
sflow timeout [receiver <rcvr_idx_list>] <timeout>

Parameters:

agent-ip	The agent IP address used as agent-address in UDP datagrams. Defaults to Ipv4 loopback address.
Collector-address	Collector address
collector-port	Collector UDP port
disable	disable
enable	enable
max-datagram-size	Maximum datagram size.
Timeout	Receiver timeout measured in seconds. The switch decrements the timeout once per second, and as long as it is non-zero, the receiver receives samples. Once the timeout reaches 0, the receiver and all its configuration is reset to defaults.

Example:

```
SISPM1040-3248-L(config)# sflow agent-ip ipv4 192.168.1.2
SISPM1040-3248-L(config)# sflow collector-port 3
SISPM1040-3248-L(config)# sflow max-datagram-size 333
SISPM1040-3248-L(config)# sflow timeout 3333
SISPM1040-3248-L(config)# sflow enable
SISPM1040-3248-L(config)# do show sflow
```

Agent Configuration:

Agent Address: 192.168.1.2

Receiver Configuration:

```
Owner      : <Configured through local management>
Receiver   : 0.0.0.0
UDP Port   : 6343
Max. Datagram: 333 bytes
Time left  : 3325 seconds
```

Flow Sampler Configuration:

No active flow samplers.

Counter Poller Configuration:

```
No active counter pollers.
SISPM1040-3248-L(config)#
```

Command: **smtp**

Description: Configure email parameters.

Syntax: **smtp** delete { server | username | sender | returnpath | mailaddress <index> }
smtp mailaddress <index> <mail_addr_name>
smtp returnpath <return_path>
smtp sender <sender_name>
smtp server <hostname>
smtp username <username> <password>

Parameters:	delete	Delete command
	mailaddress	Configure email address
	returnpath	Configure email return path
	sender	Configure email sender
	server	Configure email server
	username	Configure email user name
	<1-6>	Email address index
	<word47>	Up to 47 characters describing mail address
	<word47>	Up to 47 characters describing returnpath
	<word47>	Up to 47 characters describing sender
	<word47>	Up to 47 characters describing email server
	<word31>	Up to 47 characters describing user name
	<word31>	Configure email password
	mailaddress	Delete email address
	returnpath	Delete returnpath
	sender	Delete sender
	server	Delete email server
	username	Delete username and password

Example:

```
SISPM1040-3248-L(config)# smtp mailaddress 1 jeffs@lantronix.com
SISPM1040-3248-L(config)# smtp returnpath BobsOffice
SISPM1040-3248-L(config)# smtp sender TomT
SISPM1040-3248-L(config)# smtp server EngPC2
SISPM1040-3248-L(config)# smtp username theLab SvtAdmin
SISPM1040-3248-L(config)# do show smtp
Mail Server      : EngPC2
User Name       : theLab
Password        : *****
Sender          : TomT
Return Path     : BobsOffice
Email Address 1 : jeffs@lantronix.com
Email Address 2 :
```

```
Email Adress 3 :  
Email Adress 4 :  
Email Adress 5 :  
Email Adress 6 :  
SISPM1040-3248-L(config)# smtp delete sender  
SISPM1040-3248-L(config)# do show smtp  
Mail Server      : EngPC2  
User Name        : theLab  
Password         : *****  
Sender           :  
Return Path      : BobsOffice  
Email Adress 1   : jeffs@lantronix.com  
Email Adress 2   :  
Email Adress 3   :  
Email Adress 4   :  
Email Adress 5   :  
Email Adress 6   :  
SISPM1040-3248-L(config)#
```

Command: `snmp-server`

Description: Configure SNMP server parameters.

Syntax:

snmp-server

```
snmp-server access <group_name> model { v1 | v2c | v3 | any } level { auth | noauth | priv } [ read <view_name> ] [ write <write_name> ]
```

```
snmp-server community <v3_comm> [ { ip-range <v_ipv4_addr> <v_ipv4_netmask> | ipv6-range <v_ipv6_subnet> } ] { <v3_sec> | encrypted <v3_sec_enc> }
```

```
snmp-server community readcommunity { enable | disable }
```

```
snmp-server community writecommunity { enable | disable }
```

```
snmp-server contact <v_line255>
```

```
snmp-server engine-id local <engineID>
```

```
snmp-server host <conf_name>
```

```
snmp-server location <v_line255>
```

```
snmp-server security-to-group model { v1 | v2c | v3 } name <security_name> group <group_name>
```

```
snmp-server user <username> engine-id <engineID> [ { md5 { <md5_passwd> | { encrypted <md5_passwd_encrypt> } } | sha { <sha_passwd> | { encrypted <sha_passwd_encrypt> } } } [ priv { des | aes } { <priv_passwd> | { encrypted <priv_passwd_encrypt> } } ] ]
```

```
snmp-server view <view_name> <oid_subtree> { include | exclude }
```

Parameters:	access	access configuration
	community	SNMP server community
	contact	Set the SNMP server's contact string
	engine-id	Set SNMP engine ID
	host	Set SNMP host's configurations
	location	Set the SNMP server's location string
	security-to-group	security-to-group configuration
	user	Set the SNMPv3 user's configurations
	view	MIB view configuration
	do	To run exec commands in the configuration mode
	end	Go back to EXEC mode
	exit	Exit from current mode
	help	Description of the interactive help system
	host	host configuration
	informs	Send Inform messages to this host
	no	Negate a command or set its defaults
	shutdown	Disable the trap configuration
	version	Set SNMP trap version
	<domain_name>	hostname of SNMP trap host
	<ipv4_ucast>	IP address of SNMP trap host
	<ipv6_ucast>	IP address of SNMP trap host
	<1-65535>	UDP port of the trap messages
	informs	Send Inform messages to this host

traps	Send Trap messages to this host
informs	Send Inform messages to this host
traps	Send Trap messages to this host
v1	SNMP trap version 1
v2	SNMP trap version 2
v3	SNMP trap version 3
engineID	Configure trap server's engine ID
<word10-64>	trap server's engine ID
<word32>	Username
<word32>	group name
model	security model
any	any security model
v1	v1 security model
v2c	v2c security model
v3	v3 security model
level	security level
auth	authNoPriv Security Level
noauth	noAuthNoPriv Security Level
priv	authPriv Security Level
read	specify a read view for the group
write	specify a write view for the group
model	security model
v1	v1 security model
v2c	v2c security model
v3	v3 security model
<word32>	Username
engine-id	engine ID
<word32>	MIB view name
<word255>	MIB view OID
exclude	Excluded type from the view
include	Included type from the view
<line255>	location string
<word32>	group name
<word32>	Security name
readcommunity	SNMP server ReadCommunity
writecommunity	SNMP server WriteCommunity
<line255>	contact string
local	Set SNMP local engine ID
<word10-64>	local engine ID
<word32>	Name of the host configuration
<line255>	location string
model	security model
<word32>	Username

<word32>	MIB view name
disable	Disable SNMP server ReadCommunity
enable	Enable SNMP server ReadCommunity
disable	Disable SNMP server WriteCommunity
enable	Enable SNMP server WriteCommunity
retries	retires inform messages
<0-255>	retires times
timeout	timeout parameter
<0-2147>	timeout interval
disable	disable trapmode
tcp	tcp trapmode
udp	udp trapmode

Example 1:

```

SISPM1040-3248-L(config)# snmp view viewMIB1 00000 include
first character must be '.'
SISPM1040-3248-L(config)# snmp view viewMIB1 .00000 include
SISPM1040-3166-L(config)# snmp-server contact SysAdmin@corporate-2
SISPM1040-3166-L(config)# snmp-server host SnmpSrvr-3
SISPM1040-3166-L(config-snmps-host)# ?
  do          To run exec commands in the configuration mode
  end         Go back to EXEC mode
  exit        Exit from current mode
  help        Description of the interactive help system
  host        host configuration
  informs     Send Inform messages to this host
  no          Negate a command or set its defaults
  shutdown    Disable the trap configuration
  trapmode    Configure trap mode
  version     Set SNMP trap version
SISPM1040-3248-L(config-snmps-host)# exit
SISPM1040-3248-L(config)#

SISPM1040-3166-L(config)# snmp-server location corporate-2
SISPM1040-3166-L(config)# exit
SISPM1040-3166-L# show snmp info

SNMP Info:
Conf VendorName:TN, VENDOR_GENERIC
EngineID: 800014550300c0f2493a20
config.mk oid :1.3.6.1.4.1.5205.2.214, length:9
Using   oid :1.3.6.1.4.1.868.2.80.4, length:10
Conf: EnterpriseId:868, SwitchId:2, ProductId:80, snmp-oid:868.2.80.4
SISPM1040-3166-L#

```

Example 2:

```

SISPM1040-3248-L(config)# snmp-server community readcommunity enable
SISPM1040-3248-L(config)# snmp-server community writecommunity enable
SISPM1040-3248-L(config)# do show snmp info

```

```
SNMP Info:
Conf VendorName:TN, VENDOR_TN, PRODUCT:SISPM1040-3248-L
EngineID: 800014550300c0f2493f8f
Using oid :1.3.6.1.4.1.868.2.80.7, length:10
SISPM1040-3248-L# show snmp access
Group Name      : default_ro_group
Security Model   : any
Security Level   : NoAuth, NoPriv
Read View Name   : default_view
Write View Name  : <no writeview specified>

Group Name      : default_rw_group
Security Model   : any
Security Level   : NoAuth, NoPriv
Read View Name   : default_view
Write View Name  : default_view

SISPM1040-3248-L(config-snmps-host)# informs retries 60 timeout 900
SISPM1040-3248-L(config-snmps-host)# do show snmp community
Community/Security Name : public
Source IP                : 0.0.0.0/0
Community secret         : public

Community/Security Name : private
Source IP                : 0.0.0.0/0
Community secret         : private

SISPM1040-3248-L(config-snmps-host)# do show snmp host
Trap SnmpSrvr-3 (ID:0) is disabled
Community              : public
Destination Host: INVALID!
UDP Port               : 162
Version                : V2C
Inform Mode            : disabled
Inform Timeout         : 900
Inform Retry           : 60

SISPM1040-3248-L(config-snmps-host)# do show snmp info

SNMP Info:
Conf VendorName:TN, VENDOR_TN, PRODUCT:SISPM1040-3248-L
EngineID: 800014550300c0f2493f8f
Using oid :1.3.6.1.4.1.868.2.80.7, length:10
SISPM1040-3248-L(config-snmps-host)#
SISPM1040-3248-L(config-snmps-host)# trapmode tcp
SISPM1040-3248-L(config-snmps-host)# trapmode udp
SISPM1040-3248-L(config-snmps-host)#
```

Command: **spanning-tree**

Description: Configure Spanning Tree protocol

Syntax: **spanning-tree** aggregation
spanning-tree edge bpdu-filter
spanning-tree edge bpdu-guard
spanning-tree mode { stp | rstp | mstp }
spanning-tree mst <instance> priority <prio>
spanning-tree mst <instance> vlan <v_vlan_list>
spanning-tree mst forward-time <fwdtime>
spanning-tree mst hello-time <hellotime>
spanning-tree mst max-age <maxage> [forward-time <fwdtime>]
spanning-tree mst max-hops <maxhops>
spanning-tree mst name <name> revision <v_0_to_65535>
spanning-tree recovery interval <interval>
spanning-tree transmit hold-count <holdcount>

Parameters:	aggregation	Aggregation mode
	edge	Edge ports
	mode	STP protocol mode
	mst	STP bridge instance
	recovery	The error recovery timeout
	transmit	BPDUs to transmit
	do	To run exec commands in the configuration mode
	end	Go back to EXEC mode
	exit	Exit from current mode
	help	Description of the interactive help system
	no	Negate a command or set its defaults
	spanning-tree	Spanning Tree protocol
	auto-edge	Auto detect edge status
	bpdu-guard	Enable/disable BPDU guard
	edge	Edge port
	link-type	Port link-type
	mst	STP bridge instance
	restricted-role	Port role is restricted (never root port)
	restricted-tcn	Restrict topology change notifications
	root-guard	Enable/disable root guard
	bpdu-filter	Enable BPDU filter (stop BPDU tx/rx)
	bpdu-guard	Enable BPDU guard
	bpdu-filter	Enable BPDU filter (stop BPDU tx/rx)
	bpdu-guard	Enable BPDU guard
	mstp	Multiple Spanning Tree (802.1s)
	rstp	Rapid Spanning Tree (802.1w)
	stp	802.1D Spanning Tree

<0-7>	instance (CIST=0, MSTI1=1...)
forward-time	Delay between port states
hello-time	MSTP bridge hello time
max-age	Max bridge age before timeout
max-hops	MSTP bridge max hop count
name	Name keyword
priority	Priority of the instance
vlan	VLAN keyword
<0-61440>	Represents the STP bridge priority. Supported values are 0/4096/8192/12288/16384/20480/24576/28672/32768/36864/40960/45056/49152/53248/57344/61440 (i.e divisible by 4096). Default value is 32768
<vlan_list>	Range of VLANs
interval	The interval
<30-86400>	Range in seconds
hold-count	Max number of transmit BPDUs per sec
<1-10>	1-10 per sec, 6 is default
<cr>	

Example:

```
SISPM1040-3248-L(config)# spanning-tree transmit hold-count 4
SISPM1040-3248-L(config)# spanning-tree aggregation
SISPM1040-3248-L(config-stp-aggr)# spanning-tree edge bpdu-guard
SISPM1040-3248-L(config)# spanning-tree edge bpdu-guard
SISPM1040-3248-L(config)# spanning-tree mode stp
SISPM1040-3248-L(config)# spanning-tree mst name a revision 4
SISPM1040-3248-L(config)# spanning-tree recovery interval 33
SISPM1040-3248-L(config)# spanning-tree transmit hold-count 3
SISPM1040-3248-L(config)#
```

Command: **svl**

Description: Configure Shared VLAN Learning. With Shared and Independent VLAN Learning (SVL and IVL), Bridges can learn MAC Addresses from each received frame's source address field, so that subsequently forwarded frames whose destination addresses have been learned can be filtered to restrict their transmission to the LANs necessary to reach their destination. Addresses learned from frames with one VLAN Identifier (VID) may or may not be used to filter frames with another VID, depending on the capabilities of the bridge implementation and management controls.

SVL: If learned information is shared for two or more given VIDs, those VIDs map to a single Filtering Identifier (FID) and the term 'Shared VLAN Learning' is used to describe their relationship.

IVL: If learned information is not shared, the VIDs map to different FIDs and Independent VLAN Learning is being used.

Syntax: **svl fid <fid> vlan <vlan_list>**

Parameters:

fid	Filter ID keyword
<1-4095>	Filter ID
vlan	VLAN keyword
<vlan_list>	VLAN List

Example:

```
SISPM1040-3248-L(config)# svl fid 1 vlan 3
SISPM1040-3248-L(config)# do show svl
FID  VLANs
-----
1,3
SISPM1040-3248-L(config)#
```

Messages: %% Failed to add VLAN Translation mapping. % (VLAN Translation Error – The provided Translation VLAN ID is the same as the VLAN ID – makes no sense to translate a VLAN to itself).

Command: **switchport**

Description: Set VLAN switching mode characteristics.

Syntax: **switchport** vlan mapping <gid> <vlan_list> <tvid>
switchport vlan mapping <gid> { both | ingress | egress } <vid> <tvid>

Parameters:

vlan	VLAN
mapping	VLAN translation entry configuration.
<1-32>	Group id
<vlan_list>	VLAN ID List (deprecated)
both	Bi-directional Translation
egress	Egress-only Translation
ingress	Ingress-only Translation
<vlan_id>	VLAN ID
<vlan_id>	Translated VLAN ID

Example:

```
SISPM1040-3248-L(config)# switchport vlan mapping 3 4 5  
SISPM1040-3248-L(config)#
```

Command: **system**

Description: Set system parameters and SNMP server parameters.

Syntax:

```

system contact <v_line128>
system description <sys_desc>
system di reboot { enable | disable }
system di { high | low }
system do relay { open | close }
system do { open | close }
system location <v_line128>
system name <v_line128>
system reboot mode { enable | disable }
system reboot { [ Sun <hour_v00_0_to_23> <min_v00_0_to_55> ] [ Mon <hour_v10_0_to_23>
<min_v10_0_to_55> ] [ Tue <hour_v20_0_to_23> <min_v20_0_to_55> ] [ Wed <hour_v30_0_to_23>
<min_v30_0_to_55> ] [ Thr <hour_v40_0_to_23> <min_v40_0_to_55> ] [ Fri <hour_v50_0_to_23>
<min_v50_0_to_55> ] [ Sat <hour_v60_0_to_23> <min_v60_0_to_55> ] }

```

Parameters:	contact	Set the SNMP server's contact string
	description	Configure System Description
	di	Set the Switch DI input configurations
	do	Set the Switch DO output configurations
	location	Set the SNMP server's location string
	name	Set the SNMP server's system model name string
	reboot	Set the Switch Reboot configurations
	<line128>	contact string
	<line128>	System Description string
	high	Set High is Normal mode
	low	Set low is Normal mode
	close	Set close is Normal mode
	open	Set open is Normal mode
	relay	Set the Switch DO relay configurations
	close	Set off for DO to close state
	open	Set on for DO to open state
	reboot	Set the Switch DI reboot configurations
	<line128>	location string
	<line128>	location string
	<line128>	name string
	Fri	Configure Switch Reboot scheduling on Friday
	Mon	Configure Switch Reboot scheduling on Monday
	Sat	Configure Switch Reboot scheduling on Saturday
	Sun	Configure Switch Reboot scheduling on Sunday
	Thr	Configure Switch Reboot scheduling on Thursday
	Tue	Configure Switch Reboot scheduling on Tuesday

Wed	Configure Switch Reboot scheduling on Wednesday
mode	Switch reboot mode
disable	Disable Switch Reboot
enable	Enable Switch Reboot
<0-23>	start hour
<0-55>	start minute, value must be multiples of 5
disable	Set DI reboot system to Disable
enable	Set DI reboot system to “When DI was changed to abnormal”. Set the reboot system of the digital input (DI). The default setting is Disabled (no reboot system action taken). You can set it to “When DI was changed to abnormal” to reboot the switch when DI input goes High. Added at FW v 7.20.0075.

Example:

```

SISPM1040-3248-L(config)# system contact BobB in Itdept
SISPM1040-3248-L(config)# system description 3248-L SwitchIT
SISPM1040-3248-L(config)# system di high
SISPM1040-3248-L(config)# system do close
SISPM1040-3248-L(config)# system do relay open
SISPM1040-3248-L(config)# system di reboot disable
SISPM1040-3248-L(config)# system di reboot enable
SISPM1040-3248-L(config)# system reboot Sun 12 30
SISPM1040-3248-L(config)# system name IT 3248-L
IT 3248-L(config)# system name SISPM1040-3248-L
SISPM1040-3248-L(config)# system location Plymouth office
SISPM1040-3248-L(config)# do show system
Model Name                : SISPM1040-3248-L
System Description        : 3248-L SwitchIT
Location                  : Plymouth office
Contact                   : BobB in Itdept
System Name               : SISPM1040-3248-L
System Date               : 2021-01-01T18:57:34+00:00
System Uptime             : 18:57:59
Bootloader Version       : V1.01
Firmware Version         : v8.50.0149 2024-05-11
PoE Firmware Version     : 208-211
Hardware Version         : v1.02
Mechanical Version       : v1.01
Serial Number             : A139119BR2500001
MAC Address               : 00-c0-f2-49-3f-8f
Powers Status            : Normal
Temperature Status       : Normal
Temperature 1             : 44(C) ; 111(F)
Temperature 2             : 43(C) ; 109(F)
SISPM1040-3248-L(config)# do show system reboot

```

Switch Reboot Mode: Disable

Switch Reboot Entry:

```

Reboot Time
Week Day    HH : MM
-----
Monday      -  -
Tuesday     -  -
Wednesday   -  -
Thursday    -  -
Friday      -  -
Saturday    -  -
Sunday      12 30

SISPM1040-3248-L(config)#

```

Command: **tacacs-server**

Description: Configure TACACS+ parameters.

Syntax: **tacacs-server** deadtime <minutes>

tacacs-server host <host_name> [port <port>] [timeout <seconds>] [key { [unencrypted] <unencrypted_key> | encrypted <encrypted_key> }] tacacs-server key { [unencrypted] <unencrypted_key> | encrypted <encrypted_key> }
tacacs-server key { [unencrypted] <unencrypted_key> | encrypted <encrypted_key> }

Parameters:

deadtime Time to stop using a TACACS+ server that doesn't respond
host Specify a TACACS+ server
key Set TACACS+ encryption key
timeout Time to wait for a TACACS+ server to reply
<word1-255> Hostname or Ipv4/Ipv6 address
<word1-63> The UNENCRYPTED (Plain Text) secret key. Notice that you have no chance to get the Plain Text secret key after this command. The system will always display the ENCRYPTED password.
<word96-224> The ENCRYPTED (hidden) secret key. Notice the ENCRYPTED secret key will be decoded by system internally. You cannot directly use it as same as the Plain Text and it is not human-readable text normally.
Encrypted Specifies an ENCRYPTED secret key will follow
unencrypted Specifies an UNENCRYPTED secret key will follow
<0-65535> TCP port number
key Server specific key (overrides default)
port TCP port for TACACS+ server
timeout Time to wait for this TACACS+ server to reply (overrides default)
<1-1000> Wait time in seconds

Example:

```

SISPM1040-3248-L(config)# tacacs-server deadtime 300
SISPM1040-3248-L(config)# tacacs-server timeout 300
SISPM1040-3248-L(config)# tacacs-server key 33

```

```
SISPM1040-3248-L(config)# tacacs-server timeout 400
SISPM1040-3248-L(config)# tacacs-server host 192.168.1.77 port 49
SISPM1040-3248-L(config)# do show tacacs-server
Global TACACS+ Server Timeout      : 400 seconds
Global TACACS+ Server Deadtime     : 300 minutes
Global TACACS+ Server Key          : a616cb339aa3b0503767006a4e6a3d92a4ecba7a857
7df9e6aceecfedb0ca23f55959d652722280ab46233c63d7de583ab2412a2643d7d2707ff8add7d8
e7428
TACACS+ Server #1:
  Host name  : 192.168.1.77
  Port       : 49
  Timeout    :
  Key        :
SISPM1040-3248-L(config)# tacacs-server host 192.168.1.77 port 49 key tacplus123!@# timeout
350
SISPM1040-3248-L(config)# do show tacacs-server
Global TACACS+ Server Timeout      : 400 seconds
Global TACACS+ Server Deadtime     : 300 minutes
Global TACACS+ Server Key          : a616cb339aa3b0503767006a4e6a3d92a4ecba7a857
7df9e6aceecfedb0ca23f55959d652722280ab46233c63d7de583ab2412a2643d7d2707ff8add7d8
e7428
TACACS+ Server #1:
  Host name  : 192.168.1.77
  Port       : 49
  Timeout    : 350 seconds
  Key        : f493bbaefe03ec73e35760e664f87b3d53eff60e396671c1858ae43a976bd3daf
af0b4340fe94900db4227cf6fb4b303062c31aa345f2547f64a45aaffb19c18
SISPM1040-3248-L(config)#
```

Messages: % Incomplete word detected at '^' marker.

Command: **traffic-test-loop**

Description: Configure Traffic Test Loop that can do looping to use for traffic testing like RFC2544 and Y.1564. TT-LOOP is a firmware module that provides methods to perform tests that are defined in IETF RFC 2544 (Benchmarking Methodology for Network Interconnect Devices) and Y.1564 (remote end).

Syntax:

```

traffic-test-loop <inst> admin-state { enabled | disabled }
traffic-test-loop <inst> ll mep <mep_id> smac <mac_address>
traffic-test-loop <inst> name <name>
traffic-test-loop <inst> subscriber [ all | untagged | { vid <vlan_id> } ]
traffic-test-loop <inst> type { mac-loop | { oam-loop [ level <level> ] } } interface <port_type> <port> direction {
terminal | facility } domain { port | { evc <evc_id> [ subscriber { all | untagged | { vid <sub_vid> } } ] } | { vlan <vlan_
_vid> } } [ admin-state { enabled | disabled } ]

```

Parameters:

<1-100>	The traffic-test-loop instance number.
Admin-state	The administrative state.
ll	Latching Loopback function.
Name	The traffic-test-loop name.
subscriber	This EVC traffic-test-loop can be matching in the subscriber domain depending on 'all' – 'untagged' – 'vid'.
Type	The type of the traffic-test-loop. Currently OAM Loop is only supported in EVC domain.
Mac-loop	This traffic-test-loop is the MAC looping type. All frames in the flow is looped with MAC swap.
Oam-loop	This traffic-test-loop is the OAM looping type. It is Y.1731 OAM aware and it is looping LBM to LBR and DMM to DMR. Currently OAM Loop is only supported in EVC domain.
Interface	The residence port of the traffic-test-loop.
Disabled	This traffic-test-loop administrative state is set to 'disabled'. The loop is deleted and operational state is 'down'.
Enabled	This traffic-test-loop administrative state is set to 'enabled'. If all required resources are available the loop is created and operational state is 'up'.
Holdtime	Sets LLDP hold time (The neighbor switch will discarded the LLDP information after 'hold time' multiplied with 'timer' seconds).
Med	Media Endpoint Discovery.
Reinit	LLDP tx reinitialization delay in seconds.
Timer	Sets LLDP TX interval (The time between each LLDP frame transmitted in seconds).
Transmission-delay	Sets LLDP transmission-delay. LLDP transmission delay (the amount of time that the transmission of LLDP frames will delayed after LLDP configuration has changed) in seconds.)
<2-10>	2-10 seconds.
Datum	Datum (geodetic system) type.
Fast	Number of times to repeat LLDP frame transmission at fast start.
Location-tlv	LLDP-MED Location Type Length Value parameter.
Media-vlan-policy	Create a policy, which can be assigned to an interface.
<1-10>	1-10 seconds.

<5-32768>	5-32768 seconds.
<1-8192>	1-8192 seconds.
<port_type_id>	Port ID in 1/1-20
direction	The direction of the traffic-test-loop. Currently Terminal Loop is only supported in EVC domain.
Facility	This traffic-test-loop is pointing out to the port. Looping is done from ingress to egress.
Terminal	This traffic-test-loop is pointing into the forwarding plane. Looping is done from egress to ingress.
Domain	The domain of the traffic-test-loop. Currently VLAN domain is not supported.
Evc	This traffic-test-loop is in the EVC domain. Looped frames are frames in the EVC. Handled OAM is with EVC tag.
Port	This traffic-test-loop is in the Port domain. Looped frames are frames on the port. Handled OAM is untagged.
Vlan	This traffic-test-loop is in the VLAN domain. Looped frames are frames in the VLAN. Handled OAM is with VLAN tag. This is currently not supported.
<uint>	The EVC Domain instance id.
Admin-state	The administrative state.
GigabitEthernet	1 Gigabit Ethernet Port
10GigabitEthernet	10 Gigabit Ethernet Port
<vlan_id>	The VLAN Domain VID.
Disabled	This traffic-test-loop administrative state is set to 'disabled'. The loop is inactivated and operational state is 'down'.
Enabled	This traffic-test-loop administrative state is set to 'enabled'. If all required resources are available the loop is activated and operational state is 'up'. This is the default value.
Interface	The residence port of the traffic-test-loop.
Level	The Y.1731 OAM level of the traffic-test-loop. Only relevant for OAM looping type traffic-test-loop.
All	This EVC traffic-test-loop is matching on all subscriber domain frames.
Untagged	This EVC traffic-test-loop is matching on untagged subscriber domain frames.
Vid	This EVC traffic-test-loop is matching on tagged subscriber domain frames with a specific VID.
<vlan_id>	The Subscriber VLAN Domain VID.

Example:

```
SISPM1040-3248-L(config)# traffic-test-loop 1 admin-state enabled
SISPM1040-3248-L(config)# ll reinit 4
SISPM1040-3166-L(config)# traffic-test-loop 1 ll mep 1 smac 11-22-33-44-55-66
% Error: instance is not created
SISPM1040-3166-L(config)# traffic-test-loop 1 subscriber all
% Error: instance is not created
SISPM1040-3166-L(config)# traffic-test-loop 1 type mac interface GigabitEthernet
1/9 direction facility domain port admin-state enabled
SISPM1040-3166-L(config)# traffic-test-loop 1 type oam level 4 interface Gigabit
Ethernet 1/9 direction terminal domain evc 1 admin-state enabled
```

Command: **udld**

Description: Enable Unidirectional Link Detection in aggressive mode or normal mode and to set the configurable message timer on all fiber-optic ports.

Syntax: **udld** { aggressive | enable | message time-interval <v_interval> }

Parameters:

aggressive Enables UDLD in aggressive mode on all fiber-optic ports.

Enable Enables UDLD in normal mode on all fiber-optic ports.

Message Configures the period of time between UDLD probe messages on ports that are in the advertisement phase and are determined to be bidirectional. The range is from 7 to 90 seconds (currently default message time interval 7 sec is supported).

Time-interval Configures the period of time between UDLD probe messages on ports that are in the advertisement phase and are determined to be bidirectional. The range is from 7 to 90 seconds (Currently default message time interval 7 sec is supported.)

<7-90> Configures the period of time between UDLD probe messages on ports that are in the advertisement phase and are determined to be bidirectional. The range is from 7 to 90 seconds (currently default message time interval 7 sec is supported).

Example:

```
SISPM1040-3248-L(config-if)# udld port aggressive message time-interval 7
SISPM1040-3248-L(config-if)#
SISPM1040-3248-L(config)# udld message time-interval 7
% Only fiber ports are allowed, port_no: 1
% Only fiber ports are allowed, port_no: 2
% Only fiber ports are allowed, port_no: 3
% Only fiber ports are allowed, port_no: 4
% Only fiber ports are allowed, port_no: 5
% Only fiber ports are allowed, port_no: 6
% Only fiber ports are allowed, port_no: 7
% Only fiber ports are allowed, port_no: 8
% Only fiber ports are allowed, port_no: 9
% Only fiber ports are allowed, port_no: 10
% Only fiber ports are allowed, port_no: 11
% Only fiber ports are allowed, port_no: 12
% Only fiber ports are allowed, port_no: 13
% Only fiber ports are allowed, port_no: 14
% Only fiber ports are allowed, port_no: 15
% Only fiber ports are allowed, port_no: 16
% Only fiber ports are allowed, port_no: 17
% Only fiber ports are allowed, port_no: 18
% Only fiber ports are allowed, port_no: 19
% Only fiber ports are allowed, port_no: 20
% Only fiber ports are allowed, port_no: 21
% Only fiber ports are allowed, port_no: 22
-- more --, next page: Space, continue: g, quit: ^C
SISPM1040-3248-L(config-if)# udld port
SISPM1040-3248-L(config-if)#
```

Command: **upnp**

Description: Set UpnP configuration. UpnP (Universal Plug and Play) allows devices to connect seamlessly and simplify implementation of networks in a home environment or corporate environment.

Syntax: **upnp** <cr>
upnp advertising-duration <v_66_to_86400>
upnp ip-addressing-mode { dynamic | static }
upnp static interface vlan <v_vlan_id>

Parameters:	advertising-duration	Set advertising duration
	ip-addressing-mode	Set IP addressing mode
	static	Set static VLAN interface ID
	interface	Select an interface to configure
	vlan	VLAN Interface
	<vlan_id>	VLAN identifier (VID)
	<66-86400>	advertising duration
	dynamic	Dynamic IP addressing mode
	static	Static IP addressing mode
	<cr>	

Example:

```
SISPM1040-3248-L(config)# upnp advertising-duration 300
SISPM1040-3248-L(config)# upnp ip-addressing-mode static
SISPM1040-3248-L(config)# upnp ip-addressing-mode dynamic
SISPM1040-3166-L(config)# upnp static interface vlan 100
SISPM1040-3248-L(config)#
```

Command: **username**

Description: Establish User Name Authentication.

Syntax: **username** { default-administrator | <input_username> } privilege <priv> password { unencrypted <unencyr_password> | encrypted <encyr_password> | none }

Parameters:

<word31> User name allows letters, numbers and underscores.

Privilege Set user privilege level

<0-15> User privilege level

password Specify the password for the user

encrypted Specifies an ENCRYPTED password will follow

none NULL password

unencrypted Specifies an UNENCRYPTED password will follow

<word128> The ENCRYPTED (hidden) user password. Notice the ENCRYPTED password will be decoded by system internally. You cannot directly use it as same as the Plain Text and it is not human-readable text normally.

Example:

```
SISPM1040-3248-L(config)# username JeffS privilege 15 password none
SISPM1040-3248-L(config)# do show user-privilege
username JeffS privilege 15 password encrypted 6ad5b341a4367ec77eea8fa8f04416ab9
250fac98234e05f901b82553f895b36fe2c85abe10e148fcf8220abdbcf94f639b366b1af7b810b0
efcd37bd2ad1a7e
username admin privilege 15 password encrypted fc66f42a1487289ff10446f9daf6bce21
601df4754810206b22a724b2c5232c0829fe3e2a521cc607ae677dbf0c0b71e85746fbba7fc3d51d
4804f3ad7df279e
SISPM1040-3248-L(config)#
```

Messages:

% Invalid word detected at '^' marker.

% Incomplete word detected at '^' marker.

% Fail to configure the user

% (Invalid password)

Command: **vlan**

Description: Configure VLAN commands.

Syntax: **vlan** <vlist>**vlan** ethertype s-custom-port <etype>**vlan** protocol { { eth2 { <etype> | arp | ip | ipx | at } } | { snap { <oui> | rfc-1042 | snap-8021h } <pid> } | { llc <dsap> <ssap> } } group <grp_id>

Parameters:

<vlan_list>	ISL VLAN IDs
ethertype	EtherType for Custom S-ports
protocol	Protocol-based VLAN commands
do	To run exec commands in the configuration mode
end	Go back to EXEC mode
exit	Exit from current mode
help	Description of the interactive help system
name	ASCII name of the VLAN
no	negate
s-custom-port	Custom S-ports configuration
ethertype	EtherType for Custom S-ports
s-custom-port	Custom S-ports configuration
<0x0600-0xffff>	EtherType (Range: 0x0600-0xffff)
eth2	Ethernet-based VLAN commands
llc	LLC-based VLAN group
snap	SNAP-based VLAN group
<0x600-0xffff>	Ether Type (Range: 0x600 – 0xFFFF)
arp	Ether Type is ARP
at	Ether Type is AppleTalk
ip	Ether Type is IP
ipx	Ether Type is IPX
<word31>	The ASCII name for the VLAN
<0x0-0xfffff>	SNAP OUI (Range 0x000000 – 0FFFFFFF)
rfc-1042	SNAP OUI is rfc-1042
snap-8021h	SNAP OUI is 8021h
<0x0-0xff>	DSAP (Range: 0x00 – 0xFF)
group	Protocol-based VLAN group commands
<word16>	Group Name (Range: 1 – 16 characters)
group	Protocol-based VLAN group commands

Example:

```

SISPM1040-3248-L(config)# vlan 10 ?
  <cr>
SISPM1040-3248-L(config)# vlan ethertype s-custom-port 0x0800
SISPM1040-3248-L(config)# vlan protocol eth2 ip group mygroup
SISPM1040-3166-L(config-vlan)# name VlanVID100
SISPM1040-3166-L(config)# vlan protocol eth2 ipx group 1
SISPM1040-3166-L(config)#

```

Command: voice

Description: Configure Voice appliance attributes.

Syntax: **voice** vlan
voice vlan aging-time <aging_time>
voice vlan class { <traffic_class> | low | normal | medium | high }
voice vlan oui <oui> [description <description>]
voice vlan vid <vid>

Parameters: vlan VLAN for voice traffic
aging-time Set secure learning aging time
class Set traffic class
oui Organizationally Unique Identifier configuration
vid Set VLAN ID
<10-10000000> Aging time, 10-10000000 seconds
<0-7> Traffic class value
<oui> OUI value (in the format xx-yy-zz)
<vlan_id> VLAN ID, 1-4095

Example:

```
SISPM1040-3248-L(config)# voice vlan aging-time 50000
SISPM1040-3248-L(config)# voice vlan class 5
SISPM1040-3248-L(config)# voice vlan oui ?
    <oui>    OUI value
SISPM1040-3248-L(config)# voice vlan vid 10
SISPM1040-3248-L(config)# voice vlan oui 00:C0:F2
SISPM1040-3248-L(config)# do show voice vlan
Switch voice vlan is enabled
Switch voice vlan ID is 10
Switch voice vlan aging-time is 50000 seconds
Switch voice vlan traffic class is 5

Telephony OUI  Description
-----  -----
00-C0-F2

Voice VLAN switchport is configured on following:

GigabitEthernet 1/1 :
-----
GigabitEthernet 1/1 switchport voice vlan mode is disabled
GigabitEthernet 1/1 switchport voice security is disabled
GigabitEthernet 1/1 switchport voice discovery protocol is oui

GigabitEthernet 1/2 :
-----
GigabitEthernet 1/2 switchport voice vlan mode is disabled
GigabitEthernet 1/2 switchport voice security is disabled
GigabitEthernet 1/2 switchport voice discovery protocol is oui
-- more --, next page: Space, continue: g, quit: ^C
```

Command: **web**

Description: Configure Web privileges.

Syntax: **web** privilege group <group_name> level { [cro <configRoPriv>] [crw <configRwPriv>] }*1

Parameters:

privilege Web privilege

group Web privilege group

<cword> Valid words are:

Aggregation	DHCP	DHCPv6_Client	DMS_Trouble_Shooting
DMS_Vbatch	DMS_client	DMS_server	Debug
Diagnostics	EPS	ERPS	ETH_LINK_OAM
EVC	FRR	Firmware	Green_Ethernet
HqoS	IP	IPMC_Snooping	Install_Wizard
LACP	LLDP	Loop_Protect	MAC_Table
MEP	MPLS_TP	MRP	MRP_Ring
MVR	Miscellaneous	NTP	POE
PTP	Performance_Monitor	Ports	Private_VLANs
QoS	RFC2544	Rmirror	R_RING
SMTP	Security(access)	Security(network)	Spanning_Tree
System	TT_LOOP	Trap_Event	UDLD
UpnP	VCL	VLAN_Translation	VLANs
Voice_VLAN	Watchdog	XXRP	Y.1564(SAM)
percepXion	sFlow	uFDMA_AIL	uFDMA_CIL

Example:

```
SISPM1040-3248-L(config)# web privilege group Watchdog level cro 12 crw 15
SISPM1040-3248-L(config)# web privilege group MPLS_TP level cro 12 crw 15
SISPM1040-3248-L(config)#
```

Command: **y1564**

Description: Configure ITU-T Y.1564 Ethernet Service Activation Test methodology.

Syntax: **y1564** profile <profile_name>
y1564 rename profile <old_profile_name> <new_profile_name>

Parameters:

profile	Y.1564 profile configuration
rename	Rename an existing profile
<word32>	Profile name up to 32 characters long
acceptable-fdv	Controls the acceptable FDV (Frame Delay Variation) measured in milliseconds. If exceeded, the test is considered failing. 0 effectively disables the test.
Acceptable-flr	Controls the acceptable FLR (Frame Loss Ratio) measured in permille. If exceeded, the test is considered failing. 1000 effectively disables the test.
Acceptable-ftd	Controls the acceptable FTD (Frame Transfer Delay) measured in milliseconds. If exceeded, the test is considered failing. 0 effectively disables the test.
Cir-test	Enable CIR configuration test and optionally set its parameters.
description	Add a description to profile.
do	To run exec commands in the configuration mode.
dst-oam-aware	Remote end (DST) is Y.1731 OAM aware or not (no-form) Y.1731 OAM aware. This setting sets the type of Y.1731 OAM frames transmitted from this end.
Dwell-time	Controls the number of milliseconds that the execution pauses after each trial before reading counters and status from hardware
eir-test	Enable EIR configuration test and optionally set its parameters
emix	Select the frame size (EMIX letter-encoded) that the enabled tests will use. Encoding is as follows: a: 64, b: 128, c: 256, d: 512, e: 1024, f: 1280, g: 1518, h: MTU, u: user-defined.
end	Go back to EXEC mode
exit	Exit from current mode
help	Description of the interactive help system
meg-level	Set MEG level used in Y.1731 OAM PDUs.
No	Negate a command or set its defaults
performance-test	Enable performance test and optionally set its parameters
traffic-policing-test	Enable traffic policing test and optionally set its parameters
traffic-type	Select the type of traffic generated at the near end
user-defined-frame-size	When emix is set to 'u', this one defines the frame size to use
0-10000	Acceptable frame transfer delay measured in milliseconds
0-1000	Acceptable frame loss ratio measured in permille
0-10000	Acceptable frame transfer delay measured in milliseconds
dm-interval	Interval in ms between sending delay measurement frames. Set 0 to disable.
Duration	Set the duration of one step (trial)
step-count	Set the number of steps required to reach CIR.
<line128>	Profile description.
<line>	Exec Command

100-10000	Dwell time measured in milliseconds
dm-interval	Interval in ms between sending delay measurement frames. Set 0 to disable.
Duration	Set the duration of the test
<word32>	EMIX letter-encoded string identifying the frame sizes to use simultaneously during the test.
0-7	MEG level
customer-simulated	Transmit frames that simulate real customer traffic as test traffic
oam	Transmit Y.1731 OAM as test traffic
64-10236	User-defined frame size in bytes

Example:

```
SISPM1040-3248-L(config-y1564-profile)# acceptable-ftd 5000
SISPM1040-3248-L(config-y1564-profile)# dst-oam-aware
SISPM1040-3248-L(config-y1564-profile)# meg-level 2
SISPM1040-3248-L(config-y1564-profile)# traffic-type oam
SISPM1040-3248-L(config-y1564-profile)# traffic-type customer-simulated
SISPM1040-3248-L(config-y1564-profile)# user-defined-frame-size 5000
SISPM1040-3248-L(config-y1564-profile)# emix g
SISPM1040-3248-L(config-y1564-profile)# performance-test dm-interval 600 duration 7000
SISPM1040-3248-L(config-y1564-profile)#
```

Chapter 6 Interface Config Mode Commands

The Interface Config mode commands are listed and described below.

Command	Description
access-list	Access list
aggregation	Create an aggregation
description	Configures port description
do	To run exec commands in the configuration mode
dot1x	IEEE Standard for port-based Network Access Control
duplex	Interface duplex
end	Go back to EXEC mode
evc	Ethernet Virtual Connections
event	Configure port event settings
excessive-restart	Restart backoff algorithm after 16 collisions
exit	Exit from current mode
flowcontrol	Traffic flow control.
frame-length-check	Drop frames with mismatch between EtherType/Length field and actually payload size.
green-ethernet	Green Ethernet (Power reduction)
gvrp	Enable GVRP on interface or interfaces
help	Description of the interactive help system
hqos	Hierarchical Quality of Service
ip	Interface Internet Protocol configuration commands
ipv6	Ipv6 configuration commands
lACP	LACP port configuration
link-oam	Enable or Disable (when the no keyword is entered) Link OAM on the interface
lldp	Link Layer Discover Protocol.
loop-protect	Loop protection configuration on port
mac	MAC keyword
mrp	Media Redundancy Protocol
mtu	Maximum transmission unit
mvr	Multicast VLAN Registration configuration
mvrp	Enable MVRP on the interface
no	To clear port description
poE	Power Over Ethernet.
port-security	Enable/disable port security per interface.
priority-flowcontrol	Priority Flow Control (802.1Qbb)
ptp	Precision time Protocol (1588)
pvlan	Private VLAN
qos	Quality of Service
rmon	Configure Remote Monitoring on an interface
sflow	Statistics flow.
shutdown	Shutdown of the interface.
spanning-tree	Spanning Tree protocol

speed	Configures interface speed.
switchport	Set VLAN switching mode characteristics
udld	UDLD configurations.

Command: interface

Description: Select an interface to configure.

Syntax: **interface** (<port_type> [<plist>])
interface llag <llag_id>
interface vlan <vlist>

Parameters:	<port_type_list>	Port list for all port types (*,GigabitEthernet, or 10GigabitEthernet).
	*	All switches or All ports
	GigabitEthernet	1 Gigabit Ethernet Port
	10GigabitEthernet	10 Gigabit Ethernet Port
	llag	Local link aggregation interface configuration
	vlan	VLAN interface configurations
	port	e.g., 1/4-9
	<cr>	

Example:

```
SISPM1040-3248-L(config)# interface ?
*                All switches or All ports
GigabitEthernet  1 Gigabit Ethernet Port
10GigabitEthernet 10 Gigabit Ethernet Port
llag              Local link aggregation interface configuration
vlan              VLAN interface configurations
SISPM1040-3248-L(config)#
```

Command: **access-list**

Description: Configure Access list for an interface.

Syntax:

access-list action { permit | deny }

access-list logging

access-list mirror

access-list policy <policy_id>

access-list port-state

access-list rate-limiter <rate_limiter_id>

access-list shutdown

access-list { redirect } interface { <port_type> <port_type_id> | (<port_type> [<port_type_list>]) }

Parameters:

action Access list action

logging Logging frame information. **Note:** The logging feature only works when the packet length is less than 1518 (without VLAN tags) and the System Log memory size and logging rate is limited.

Mirror Mirror frame to destination mirror port

policy Policy

port-state Re-enable shutdown port that was shutdown by access-list module

rate-limiter Rate limiter

redirect Redirect frame to specific port

shutdown Shutdown incoming port. The shutdown feature only works when the packet length is less than 1518 (without VLAN tags).

Deny Deny

permit Permit

<1-16> Rate limiter ID

interface Select an interface to configure

* All switches or All ports

GigabitEthernet 1 Gigabit Ethernet Port

10GigabitEthernet 10 Gigabit Ethernet Port

<port_type_list> Port list for all port types

<cr>

Example:

```
SISPM1040-3166-L(config-if)# access-list policy 1
SISPM1040-3166-L(config-if)# access-list port-state
SISPM1040-3166-L(config-if)# access-list rate-limiter 1
% Port redirect cannot be configured while permitted action on GigabitEthernet 1/1.
SISPM1040-3166-L(config-if)# access-list mirror
SISPM1040-3166-L(config-if)#
```

Command: aggregation

Description: Create an aggregation group

Syntax: **aggregation** group <v_uint> mode { active | on | passive }

Parameters:

group	Create an aggregation group
1-11	The aggregation group id
mode	The mode of the aggregation
active	Active LACP
on	Static aggregation
passive	Passive LACP
<cr>	

Example:

```
SISPM1040-3248-L(config-if)# aggregation group 1 mode active
SISPM1040-3166-L(config-if)# aggregation group 1 mode on
SISPM1040-3166-L(config-if)#
```

Messages: The aggregation cannot include more than 16 ports**Command:** description

Description: Configures port description for an interface.

Syntax: <line16> Up to 16 characters describing this interface

Parameters: **description** <description>

Example:

```
SISPM1040-3248-L(config-if)# description Bob
SISPM1040-3248-L(config-if)#
```

Command: do

Description: To run exec commands in Configuration mode.

Syntax: **do** <command>

Parameters: <line> Exec Command

Example:

```
SISPM1040-3166-L(config-if)# do show version brief
Version      : SISPM1040-3248-L (standalone) v8.50.0149
Build Date   : 2024-05-14T12:32:27+08:00
SISPM1040-3248-L(config-if)#
```

Command: **dot1x**

Description: IEEE Standard for port-based Network Access Control

Syntax: **dot1x** guest-vlan
dot1x port-control { force-authorized | force-unauthorized | auto | single | multi | mac-based }
dot1x radius-qos
dot1x radius-vlan
dot1x re-authenticate

Parameters: guest-vlan Enables/disables guest VLAN
port-control Sets the port security state.
Radius-qos Enables/disables per-port state of RADIUS-assigned QoS.
Radius-vlan Enables/disables per-port state of RADIUS-assigned VLAN.
Re-authenticate Refresh (restart) 802.1X authentication process.
Auto Port-based 802.1X Authentication
force-authorized Port access is allowed
force-unauthorized Port access is not allowed
mac-based Switch authenticates on behalf of the client
multi Multiple Host 802.1X Authentication
single Single Host 802.1X Authentication

Example:

```
SISPM1040-3248-L(config-if)# dot1 guest
SISPM1040-3166-L(config-if)# dot1x port-control single
% (The 802.1X Admin State must be set to Authorized for ports that are enabled for Spanning
Tree)
SISPM1040-3166-L(config-if)# dot1x radius-qos
SISPM1040-3166-L(config-if)# dot1x radius-vlan
SISPM1040-3166-L(config-if)#
```

Command: **duplex**

Description: Configure duplex for an Interface.

Syntax: **duplex** { half | full | auto [half | full] }

Parameters: auto Auto negotiation of duplex mode.
Full Forced full duplex.
Half Forced half duplex.

Example:

```
SISPM1040-3248-L(config-if)# duplex auto
SISPM1040-3248-L(config-if)# duplex full
SISPM1040-3248-L(config-if)# duplex half
SISPM1040-3248-L(config-if)#
```

Messages: 10GigabitEthernet 1/4 does only support half duplex in 10 and 100 Mbit mode, duplex changed to full duplex.

Command: **end**
 Description: Go back to EXEC mode.
 Syntax: **end** <cr>
 Parameters: None.
 Example:

```
SISPM1040-3166-L(config-if)# end
SISPM1040-3166-L#
```

Command: **evc**
 Description: Configure Ethernet Virtual Connections for an interface.
 Syntax:
evc <evc_id> hqos <hqos_id>
evc [update] [dei { colored | fixed }] [tag { inner | outer }] [key { double-tag | normal | ip-addr | mac-ip-addr }] [key-advanced { double-tag | normal | ip-addr | mac-ip-addr }] [addr { source | destination }] [addr-advanced { source | destination }] [l2cp { [peer <l2cp_peer_list>] [forward <l2cp_forward_list>] [discard <l2cp_discard_list>] [<l2cp_id> class { <cosid> | disable }] } *1]
evc policer [update] <evc_id> class <cosid> [{ enable | disable }] [type { mef | single }] [mode { coupled | aware | blind }] [rate-type { line | data }] [cir <cir>] [cbs <cbs>] [eir <eir>] [ebs <ebs>]
evc rule [update] <evc_id> [role { nni | root | leaf | disable }] [encapsulation { <encap_id> | disable }] [l2cp { <l2cp_profile> | disable }] [force { s-tag | c-tag }]
 Parameters:
 <1-454> EVC identifier
 addr Setup address match mode
 key Setup basic (first) ingress lookup key type
 l2cp Setup L2CP forwarding
 policer Setup EVC policer for COSID
 rule Setup EVC rule configuration for port
 update Update existing entry
 hqos Hierarchical Quality of Service
 <1-256> HqoS ID
 destination Match DMAC and DIP
 source Match SMAC and SIP
 double-tag Match outer tag, inner tag, IP protocol, DSCP and DPORT
 ip-addr Match outer tag, SMAC/DMAC, IP protocol, DSCP, SIP and DIP
 mac-ip-addr Match outer tag, inner tag, SMAC, DMAC, IP protocol, DSCP, SIP, DIP, SPORT and DPORT
 normal Match outer tag, SMAC/DMAC, IP protocol, DSCP, SIP/DIP, SPORT and DPORT
 <0-31> Select BPDU addresses (0-15) and GARP addresses (16-31)
 discard Discard L2CP frames
 forward Forward L2CP frames
 peer Peer L2CP frames
 <1-454> EVC identifier

update	Update existing entry
<1-454>	EVC identifier
update	Update existing entry
addr	Setup address match mode
key	Setup basic (first) ingress lookup key type
l2cp	Setup L2CP forwarding
encapsulation	Encapsulation
force	force to add vlan tag
l2cp	Setup L2CP profile
role	Setup port role
<0-907>	Encapsulation ID
disable	Disable encapsulation
c-tag	C-tag
s-tag	S-tag
<0-62>	L2CP profile
disable	Disable L2CP profile
disable	Not UNI/NNI
leaf	Leaf UNI role
nni	NNI port role
root	Root UNI role

Example:

```
SISPM1040-3166-L(config-if)# evc addr destination key normal l2cp forward 1
SISPM1040-3166-L(config-if)# evc 1 hqos 1
% EVC 1 does not exist
SISPM1040-3166-L(config-if)# evc addr source
SISPM1040-3248-L(config-if)# evc rule 1 encapsulation 0 force c-tag l2cp 0 role leaf
SISPM1040-3248-L(config-if)#
```

Messages: % EVC 1 does not exist

Command: **event**

Description: Configure port event settings for an interface.

Syntax: **event** { active { enable | disable } | link-on { enable | disable } | link-off {enable | disable } | overload { enable | disable } | rx-threshold <rx_threshold> | traffic-duration <traffic_duration> | syslog { enable | disable } | trap { enable | disable } | smtp { enable | disable } | switch2go { enable | disable } | digital-out { enable | disable } | severity <severity> }

Parameters:	active	Active
	digital-out	Digital out
	link-off	Link Off
	link-on	Link On
	overload	Traffic Overload
	rx-threshold	Rx threshold
	severity	Severity
	smtp	Sntp
	syslog	Syslog
	traffic-duration	Traffic duration
	trap	Trap
	<0-7>	<0> Emergency ,<1> Alert ,<2> Critical ,<3> Error ,<4> Warning, <5> Notice ,<6> Informationl ,<7> Debug
	disable	Active disable
	enable	Active enable
	disable	Digital out disable
	enable	Digital out enable
	disable	Link Off disable
	enable	Link Off enable
	disable	Link On disable
	enable	Link On enable
	disable	Traffic Overload disable
	enable	Traffic Overload enable
	<0-100>	Rx threshold 0-100
	disable	Syslog disable
	enable	Syslog enable
	<1-300>	Traffic duration 1-300
	disable	Sntp disable
	enable	Sntp enable
	disable	Trap disable
	enable	Trap enable

Example:

```
SISPM1040-3248-L(config-if)# event severity 3
SISPM1040-3248-L(config-if)# event smtp enable
SISPM1040-3248-L(config-if)# event trap enable
SISPM1040-3248-L(config-if)# event rx-threshold 5
SISPM1040-3248-L(config-if)#
```

Command: **excessive-restart**

Description: Restart backoff algorithm after 16 collisions. No excessive-restart means discard frame after 16 collisions.

Syntax: **excessive-restart** <cr>

Parameters: None.

Example:

```
SISPM1040-3248-L(config-if)# excessive-restart
SISPM1040-3248-L(config-if)#
```

Messages:

GigabitEthernet 1/25 does not support this mode/speed
GigabitEthernet 1/26 does not support this mode/speed
GigabitEthernet 1/27 does not support this mode/speed
GigabitEthernet 1/28 does not support this mode/speed
10GigabitEthernet 1/1 does not support this mode/speed
10GigabitEthernet 1/2 does not support this mode/speed
10GigabitEthernet 1/3 does not support this mode/speed
10GigabitEthernet 1/4 does not support this mode/speed

Command: **exit**

Description: Exit from current mode.

Syntax: **exit** <cr>

Parameters: None.

Example:

```
SISPM1040-3248-L(config-if)# exit
SISPM1040-3248-L(config)#
```

Command: **flowcontrol**

Description: Configure Traffic flow control for an Interface.

Syntax: **flowcontrol** { on | off }

Parameters: off Disable flow control.
 On Enable flow control.

Example:

```
SISPM1040-3248-L(config-if)# flowcontrol on
SISPM1040-3248-L(config-if)# flowcontrol off
```

Command: **frame-length-check**

Description: Configure Drop frames with mismatch between EtherType/Length field and actually payload size for an Interface.

Syntax: **frame-length-check** <cr>

Parameters: None.

Example:

```
SISPM1040-3248-L(config-if)# frame-length-check
SISPM1040-3248-L(config-if)#
```

Command: **green-ethernet**

Description: Configure Green Ethernet (Power reduction) for an Interface.

Syntax: **green-ethernet** eee
green-ethernet eee urgent-queues [<urgent_queue_range_list>]
green-ethernet energy-detect
green-ethernet short-reach

Parameters:

eee Powering down of PHYs when there is no traffic.

Energy-detect Enable power saving for ports with no link partner.

Short-reach Enable power saving for ports which is connect to link partner with short cable.

Urgent-queues Enables EEE urgent queue. An urgent queue means that latency is kept to a minimum for traffic going to that queue. Note: EEE power savings will be reduced.

<range_list> EEE Interface.

Example:

```
SISPM1040-3248-L(config-if)# green-ethernet eee urgent-queues 1
SISPM1040-3248-L(config-if)# green-ethernet energy
GigabitEthernet 1/25 is not energy detect capable. Skipping
GigabitEthernet 1/26 is not energy detect capable. Skipping
GigabitEthernet 1/27 is not energy detect capable. Skipping
GigabitEthernet 1/28 is not energy detect capable. Skipping
10GigabitEthernet 1/1 is not energy detect capable. Skipping
10GigabitEthernet 1/2 is not energy detect capable. Skipping
10GigabitEthernet 1/3 is not energy detect capable. Skipping
10GigabitEthernet 1/4 is not energy detect capable. Skipping
SISPM1040-3248-L(config-if)# green-ethernet short
GigabitEthernet 1/25 is not short reach capable. Skipping
GigabitEthernet 1/26 is not short reach capable. Skipping
GigabitEthernet 1/27 is not short reach capable. Skipping
GigabitEthernet 1/28 is not short reach capable. Skipping
10GigabitEthernet 1/1 is not short reach capable. Skipping
10GigabitEthernet 1/2 is not short reach capable. Skipping
10GigabitEthernet 1/3 is not short reach capable. Skipping
10GigabitEthernet 1/4 is not short reach capable. Skipping
SISPM1040-3248-L(config-if)#
```

Command: **gvrp**

Description: Enable GVRP on interface or interfaces.

Syntax: **gvrp** <cr>

Parameters: None.

Example:

```
SISPM1040-3248-L(config-if)# gvrp
SISPM1040-3248-L(config-if)#
```

Command: **help**

Description: Description of the interactive help system

Syntax: **help** <cr>

Parameters: None.

Example:

```
SISPM1040-3248-L(config-if)# help
```

Help may be requested at any point in a command by entering a question mark '?'. If nothing matches, the help list will be empty and you must backup until entering a '?' shows the available options.

Two styles of help are provided:

Full help is available when you are ready to enter a command argument (e.g. 'show ?') and describes each possible argument.

Partial help is provided when an abbreviated argument is entered and you want to know what arguments match the input (e.g. 'show pr?').

```
SISPM1040-3248-L(config-if)#
```

Command: **hqos**

Description: Configure Hierarchical Quality of Service for an interface

Syntax: **hqos** mode { normal | basic | hierarchical }

Parameters:

mode	Setup hierarchical scheduling mode
basic	Basic Quality of Service Scheduling
hierarchical	Hierarchical Quality of Service Scheduling
normal	Normal Quality of Service Scheduling (default)

Example:

```
SISPM1040-3166-L(config-if)# hqos mode basic
SISPM1040-3166-L(config-if)# hqos mode normal
SISPM1040-3248-L(config-if)# hqos mode hierarchical
SISPM1040-3248-L(config-if)#
```

Command: **ip**

Description: Set Interface Internet Protocol (Ipv4) configuration 135arameters in Interface Config mode.

Syntax: **ip arp inspection check-vlan**
ip arp inspection logging { deny | permit | all }
ip arp inspection trust
ip dhcp snooping trust
ip igmp snooping filter <profile_name>
ip igmp snooping immediate-leave
ip igmp snooping max-groups <throttling>
ip igmp snooping mrouter
ip verify source
ip verify source limit <cnt_var>

Parameters:

arp	Address Resolution Protocol
dhcp	Dynamic Host Configuration Protocol
igmp	Internet Group Management Protocol
verify	verify command
inspection	ARP inspection
snooping	DHCP snooping
check-vlan	ARP inspection VLAN mode configuration
logging	ARP inspection logging mode configuration
trust	ARP inspection trust configuration
all	log all entries
deny	log denied entries
permit	log permitted entries
snooping	Snooping IGMP
filter	Access control on IGMP multicast group registration
immediate-leave	Immediate leave configuration
max-groups	IGMP group throttling configuration
mrouter	Multicast router port configuration
<word16>	Profile name in 16 characters
source	verify source
limit	limit command
<0-2>	the number of limit

Example:

```
SISPM1040-3248-L(config-if)# ip arp inspection trust
SISPM1040-3248-L(config-if)# ip arp inspection logging permit
SISPM1040-3248-L(config-if)# ip arp inspection check-vlan
SISPM1040-3166-L(config-if)# ip dhcp snooping trust
SISPM1040-3166-L(config-if)# ip igmp snooping immediate-leave
SISPM1040-3166-L(config-if)# ip verify source limit 1
SISPM1040-3166-L(config-if)#
```

Messages: % Please specify correct filter profile name.

% Failed to set filtering profile Fltr1.

Command: **ipv6**

Description: Configure Ipv6 MLD Snooping for an interface.

Syntax: **ipv6** mld snooping filter <profile_name>
ipv6 mld snooping immediate-leave
ipv6 mld snooping max-groups <throttling>
ipv6 mld snooping mrouter

Parameters:	snooping	Snooping MLD
	filter	Access control on MLD multicast group registration
	immediate-leave	Immediate leave configuration
	max-groups	MLD group throttling configuration
	mrouter	Multicast router port configuration
	<word16>	Profile name in 16 characters
	<1-10>	Maximum number of MLD group registration

Example:

```
SISPM1040-3248-L(config-if)# ipv6 mld snooping filter ?
  <word16>    Profile name in 16 characters
SISPM1040-3248-L(config-if)# ipv6 mld snooping filter Bob ?
  <cr>
SISPM1040-3248-L(config-if)# ipv6 mld snooping filter Bob
% Please specify correct filter profile name.

% Failed to set filtering profile Bob.

SISPM1040-3248-L(config-if)# ipv6 mld snooping immediate-leave ?
  <cr>
SISPM1040-3248-L(config-if)# ipv6 mld snooping immediate-leave
SISPM1040-3248-L(config-if)# ipv6 mld snooping max-groups ?
  <1-10>    Maximum number of MLD group registration
SISPM1040-3248-L(config-if)# ipv6 mld snooping max-groups 6 ?
  <cr>
SISPM1040-3248-L(config-if)# ipv6 mld snooping max-groups 6
SISPM1040-3248-L(config-if)# ipv6 mld snooping mrouter ?
  <cr>
```

Messages:*% Please specify correct filter profile name.**% Failed to set filtering profile Bob.*

Command: **lACP**

Description: LACP port configuration for an interface.

Syntax: **lACP** port-priority <v_1_to_65535>
lACP timeout { fast | slow }

Parameters: timeout The period between BPDU transmissions
port-priority LACP priority of the port
<1-65535> Priority value, lower means higher priority
fast Transmit BPDU each second (fast timeout)
slow Transmit BPDU each 30th second (slow timeout)

Example:

```
SISPM1040-3248-L(config-if)# lACP port-priority 600
SISPM1040-3248-L(config-if)# lACP timeout fast
SISPM1040-3248-L(config-if)#
```

Command: **link-oam**

Description: Enable or Disable (when the no keyword is entered) Link OAM on the interface.

Syntax: **link-oam** <cr>

link-oam link-monitor frame { [window <error_window>] [threshold <error_threshold>] }*1
link-oam link-monitor frame-seconds { [window <error_window>] [threshold <error_threshold>] }*1
link-oam link-monitor supported
link-oam link-monitor symbol-period { [window <error_window>] [threshold <error_threshold>] }*1
link-oam mib-retrieval supported
link-oam mode { active | passive }
link-oam remote-loopback supported
link-oam variable-retrieve { local-info | remote-info }

Parameters:

link-monitor Configure link monitoring
mib-retrieval Set MIB retrieval support
mode Set Link OAM mode Active or Passive on this interface
remote-loopback Link OAM remote loopback support
variable-retrieve Set MIB variable retrieve local info or remote info
frame Configure frame error event thresholds and window for error frames that trigger an error-frame link event
frame-seconds Configure frame seconds summary
supported Enable or Disable (when the no keyword is entered) link monitor on the interface
symbol-period Configure window and thresholds for an error-symbol period that triggers an error-symbol period link event
local-info Set MIB retrieve local info
remote-info Set MIB retrieve remote info
threshold Set a threshold in number of frames
window Set the a window of time during which error frames are counted

window Set the a window of time during which error frames are counted
 <1-60> Duration of the monitoring period in terms of seconds

Example:

```
SISPM1040-3248-L(config-if)# link-oam link-monitor supported
SISPM1040-3248-L(config-if)# link-oam link-monitor symbol-period window 1 threshold 3000000
SISPM1040-3248-L(config-if)# link-oam link-monitor symbol-period window 20 threshold 700000
SISPM1040-3248-L(config-if)# link-oam mode active
SISPM1040-3248-L(config-if)# link-oam remote-loopback supported
SISPM1040-3248-L(config-if)# link-oam variable-retrieve local-info
% This feature is not supported yet.
SISPM1040-3248-L(config-if)# link-oam variable-retrieve remote-info
% This feature is not supported yet.
SISPM1040-3248-L(config-if)# link-oam link-monitor frame threshold 20000 window 35
SISPM1040-3248-L(config-if)# link-oam mode passive
SISPM1040-3248-L(config-if)# do show link-oam
  Interface          Control   Mode      Status
  -----
GigabitEthernet    1/1      disabled  passive   non operational
GigabitEthernet    1/2      disabled  passive   non operational
GigabitEthernet    1/3      disabled  passive   non operational
GigabitEthernet    1/4      disabled  passive   non operational
GigabitEthernet    1/5      disabled  passive   non operational
GigabitEthernet    1/6      disabled  passive   non operational
GigabitEthernet    1/7      disabled  passive   non operational
-- more --, next page: Space, continue: g, quit: ^C
```

Command: **lldp**

Description: Configure Link Layer Discover Protocol for an interface.

Syntax: **lldp** cdp-aware
lldp med media-vlan policy-list <v_range_list>
lldp med transmit-tlv [capabilities] [location] [network-policy] [poe]
lldp med type { connectivity | end-point }
lldp receive
lldp tlv-select { management-address | port-description | system-capabilities | system-description | system-name }
lldp transmit
lldp trap

Parameters:

cdp-aware	Configures if the interface shall be CDP aware (CDP discovery information is added to the LLDP neighbor table)
med	Media Endpoint Discovery.
Receive	Enable/Disable decoding of received LLDP frames.
Tlv-select	Which optional TLVs to transmit.
Transmit	Enable/Disabled transmission of LLDP frames.
Trap	Configures if an SNMP trap shall be emitted when the LLDP neighbor table changes for the interface.
Connectivity	Work as connectivity device.
End-point	Work as end-point device.
Management-address	Enable/Disable transmission of management address.
Port-description	Enable/Disable transmission of port description.
System-capabilities	Enable/Disable transmission of system capabilities.
System-description	Enable/Disable transmission of system description.
System-name	Enable/Disable transmission of system name.
media-vlan	Media VLAN assignment.
Transmit-tlv	LLDP-MED Location Type Length Value parameter.
Type	Select if the interface is a 'Network Connectivity Device' or an 'Endpoint Device'. The difference between working as 'Network Connectivity Device' and an 'Endpoint Device' is a question of who is initializing the LLDP-MED TLVs transmission. A 'Network Connectivity Device' is not starting LLDP-MED TLVs transmission until it has detected an 'Endpoint Device' as link partner. An 'Endpoint Device' will start LLDP-MED TLVs transmission at once.
Policy-list	Assignment of policies.
<range_list>	Policies to assign to the interface.

Example:

```
SISPM1040-3248-L(config-if)# lldp cdp-aware
SISPM1040-3248-L(config-if)# lldp med type connectivity
SISPM1040-3248-L(config-if)# lldp receive
SISPM1040-3248-L(config-if)# lldp tlv-select management-address
SISPM1040-3248-L(config-if)# lldp tlv-select system-capabilities
```

```
SISPM1040-3166-L(config-if)# lldp trap
SISPM1040-3166-L(config-if)# lldp transmit
SISPM1040-3166-L(config-if)#
```

Messages:

Ignoring policy 1 for GigabitEthernet 1/1, because no such policy is defined

Command: **loop-protect**

Description: Configure Loop protection configuration on port.

Syntax: **loop-protect**
 loop-protect action { [shutdown] [log] }*1
 loop-protect tx-mode

Parameters: action Action if loop detected
 tx-mode Actively generate PDUs
 log Generate log
 shutdown Shutdown port

Example:

```
SISPM1040-3248-L(config-if)# loop-protect action log
SISPM1040-3248-L(config-if)# loop-protect tx-mode
SISPM1040-3166-L(config-if)# loop action log shutdown
SISPM1040-3166-L(config-if)#
```

Command: **mac address-table learning**

Description: MAC address table learning secure

Syntax: **mac address-table learning** [secure]

Parameters: secure Port Secure mode
 <cr>

Example:

```
SISPM1040-3248-L(config-if)# mac address-table learning
SISPM1040-3248-L(config-if)# mac address-table learning secure
SISPM1040-3248-L(config-if)#
```

Command: `mrp`

Description: Configure Media Redundancy Protocol for an Interface. See '[Appendix A – MRP Configuration](#)' on page [247](#) for more information.

Syntax:

`mrp periodic`

`mrp timers default`

`mrp timers { [join-time <jointime>] [leave-time <leavetime>] [leave-all-time <leavealltime>] }*1`

Parameters:

<code>periodic</code>	Enable MRP periodic transmission on the interface
<code>timers</code>	Configure MRP protocol timer parameters. IEEE 802.1Q-2014, clause 10.7.
<code>default</code>	Set all MRP timers to their default values
<code>join-time</code>	Set MRP protocol parameter JoinTime.
<code>Leave-all-time</code>	Set MRP protocol parameter LeaveAllTime.
<code>Leave-time</code>	Set MRP protocol parameter LeaveTime.
<code><1000-5000></code>	leave-all-time in units of centiseconds Range is 1000-5000. Default is 1000.
<code><60-300></code>	leave-time in units of centiseconds. Range is 60-300. Default is 60.

Example:

```
SISPM1040-3248-L(config-if)# mrp timers join-time 8 leave-all-time 2000 leave-time 125
SISPM1040-3166-L(config-if)# mrp periodic
SISPM1040-3166-L(config-if)#
```

Command: `mtu`

Description: Configure Maximum Transmission Unit for an Interface.

Syntax: `mtu <max_length>`

Parameters: `<1518-10240>` Maximum frame size in bytes.

Example:

```
SISPM1040-3248-L(config-if)# mtu 5000
SISPM1040-3248-L(config-if)#
```

Command: `mvr`

Description: Configure Multicast VLAN Registration on an interface. Multicast VLAN Registration (MVR) is a protocol for Layer 2 (IP)-networks that enables multicast-traffic from a source VLAN to be shared with subscriber-VLANs.

The main reason for using MVR is to save bandwidth by preventing duplicate multicast streams being sent in the core network, instead the stream(s) are received on the MVR-VLAN and forwarded to the VLANs where hosts have requested it/them. (Wikipedia).

Syntax: `mvr immediate-leave`
`mvr name <mvr_name> type { source | receiver }`
`mvr vlan <v_vlan_list> type { source | receiver }`

Parameters:

<code>immediate-leave</code>	Immediate leave configuration
<code>name</code>	MVR multicast name
<code>vlan</code>	MVR multicast VLAN
<code><word16></code>	MVR multicast VLAN name
<code>type</code>	MVR port role configuration
<code>receiver</code>	MVR receiver port
<code>source</code>	MVR source port
<code><vlan_list></code>	MVR multicast VLAN list
<code><cr></code>	

Example:

```
SISPM1040-3248-L(config-if)# mvr immediate-leave
SISPM1040-3248-L(config-if)# mvr name mvr1 type receiver
SISPM1040-3248-L(config-if)# mvr name mvr1 type source
SISPM1040-3248-L(config-if)# mvr vlan 100 type source
SISPM1040-3248-L(config-if)#
```

Messages: `% Invalid MVR VLAN mvr1.`

`% Failed to set MVR port role.`

`% Invalid MVR VLAN ID 100.`

Command: **mvrp**

Description: Enable MVRP on the interface. Multiple Vlan Registration Protocol is a protocol that defines the dynamic registration and de-registration of VLAN identifiers across a Bridged Local Area Network. It uses the MRP framework to define its operation and therefore it is also called a MRP Application. The standard was originally defined by IEEE 802.1ak, and its latest incorporation is in IEEE 802.1Q-2014.

Syntax: **mvrp** <cr>

Parameters: None.

Example:

```
SISPM1040-3248-L(config-if)# mvrp
SISPM1040-3248-L(config-if)#
```

Command: **no**

Description: To clear port description

Syntax: **no** <command>

Parameters:

access-list	aggregation	debug
description	dot1x	duplex
evc	excessive-restart	flowcontrol
frame-length-check	green-ethernet	gvrp
ip	ipv6	lACP
link-oam	lldp	loop-protect
mac	media-type	mrp
mtu	mvr	mvrp
poE	port-security	priority-flowcontrol
ptp	pvlan	qos
rmon	sflow	shutdown
spanning-tree	speed	switchport
udld		

Example:

```
SISPM1040-3166-L(config-if)# no lldp med media-vlan policy-list
SISPM1040-3166-L(config-if)#
```

Command: poe

Description: Configure Power over Ethernet parameters for a specified interface. **Note** that there are also Config mode PoE commands.

Syntax:

```

poe delay-mode
poe delay-time <v_0_to_300>
poe failure-action { nothing | reboot-Remote-PD }
poe hour <v_hour>
poe interval-time <interval>
poe max-reboot-times <reboot>
poe mode { enable | disable }
poe ping-ip-addr <address>
poe ping-retry-time <retry>
poe port-profile name <entry_name>
poe power limit { <v_word9> }
poe priority { low | high | critical }
poe reboot-time <reboot>
poe schedule-all
poe schedule-mode
poe startup-time <startuptime>
poe weekday { Sun | Mon | Tue | Wed | Thr | Fri | Sat } hour [ <hour_v_0_to_23>]

```

Parameters:	delay-mode	Configure PoE Power delay mode
	delay-time	Setting power delay time from 0 to 300(sec).
	failure-action	Configure PoE Auto Power Reset Failure Action.
	Hour	Configure PoE Power scheduling per hour.
	Interval-time	Configure PoE Auto Power Reset Interval Time.
	Mode	PoE mode.
	Ping-ip-addr	Configure PoE Ping IP Address.
	Ping-retry-time	Configure PoE Auto Power Reset Retry Time.
	Port-profile	poe scheduling profile
	power	Setting maximum power for port in allocation mode.
	Priority	Interface priority.
	Reboot-time	Configure PoE Auto Power Reset Reboot Time.
	Schedule-all	Configure PoE Schedule all of hours.
	Schedule-mode	Configure PoE Schedule mode.
	Startup-time	Configure PoE Auto Power Reset Start up Time.
	Weekday	Configure PoE Power scheduling on week day.
	<1-5>	Retry Time : 1 ~ 5.
	<0-300>	poe delay-time
	<ipv4_addr>	Set PoE Ping IP Address.
	{ <v_word9> }	poe power limit
	<fword2.1>	Maximum power for the interface (Class 4 PDs limited to 30W).
	limit	The maximum power.

Critical	Set priority to critical.
High	Set priority to high.
Low	Set priority to low.
<0-300>	
nothing	Failure Action : Nothing.
Reboot-Remote-PD	Failure Action : Reboot Remote PD.
<0-23>	Enter hour.
<0~23>	Enter Hour such as 0,1,5-8.
<10-120>	Interval Time : 10 ~ 120(sec).
disable	Set mode to PoE Disable
enable	Set mode to PoE Enable (Maximum power 30.0 W)
<ipv4_addr>	Set PoE Ping IP Address.
<1-5>	Retry Time : 1 ~ 5.
Name	poE scheduling profile name
<line32>	profile name, the name length is 32
limit	The maximum power.
<fword2.1>	Maximum power for the interface (Class 4 PDs limited to 30W).
critical	Set priority to critical.
High	Set priority to high.
Low	Set priority to low.
<3-120>	Reboot Time : 3 ~ 120(sec).
<30-600>	Start up Time : 30 ~ 600(sec).
Fri	Configure PoE Power scheduling on Friday.
Mon	Configure PoE Power scheduling on Monday.
Sat	Configure PoE Power scheduling on Saturday.
Sun	Configure PoE Power scheduling on Sunday.
Thr	Configure PoE Power scheduling on Thursday.
Tue	Configure PoE Power scheduling on Tuesday.
Wed	Configure PoE Power scheduling on Wednesday.

Example:

```
SISPM1040-3248-L(config-if)# poe delay-time 60
SISPM1040-3248-L(config-if)# poe ping-ip-addr 192.168.1.77 ?
SISPM1040-3248-L(config-if)# poe ping-ip-addr 192.168.1.77
SISPM1040-3248-L(config-if)# poe ping-retry-time 2
SISPM1040-3248-L(config-if)# do show poe config
SISPM1040-3248-L(config-if)# poe failure-action reboot-Remote-PD
SISPM1040-3248-L(config-if)# poe power limit 30
SISPM1040-3248-L(config-if)# poe priority critical
SISPM1040-3248-L(config-if)#
```

Messages:

GigabitEthernet 1/1 does not have PoE support

10GigabitEthernet 1/1 does not have PoE support

Maximum allowed power (for the current mode) for GigabitEthernet 1/9 is limited to 30.0 W

Command: `port-security`

Description: Enable/disable and configure port security per interface.

Syntax: `port-security``port-security maximum <limit>``port-security maximum-violation <violate_limit>``port-security sticky``port-security sticky <v_mac_addr> vlan <v_vlan_id>``port-security violation { protect | restrict | shutdown }`

Parameters:

maximum Maximum number of MAC addresses that can be learned on this set of interfaces.

Maximum-violation Maximum number of violating MAC addresses (used when violation is restrict)

sticky Enable/disable port security sticky function per interface.

Violation The action taken if limit is exceeded.

Protect Don't do anything

restrict Keep recording violating MAC addresses

shutdown Shutdown the port

Example:

```
SISPM1040-3248-L(config-if)# port-security
SISPM1040-3248-L(config-if)# port-security sticky
SISPM1040-3248-L(config-if)# port-security violation restrict
SISPM1040-3248-L(config-if)# do show port-security
```

Users:

P = Port Security (Admin)

8 = 802.1X

V = Voice VLAN

Interface	Users	Limit	Current	Violating	Violation	Mode	State
Gi 1/6	P--	4	0	0	Restrict		Ready

Aging disabled

Hold time: 300 seconds

SISPM1040-3248-L(config-if)#

SISPM1040-3166-L(config-if)# `poe power limit 30`

GigabitEthernet 1/17 does not have PoE support

GigabitEthernet 1/18 does not have PoE support

GigabitEthernet 1/19 does not have PoE support

GigabitEthernet 1/20 does not have PoE support

10GigabitEthernet 1/1 does not have PoE support

10GigabitEthernet 1/2 does not have PoE support

SISPM1040-3166-L(config-if)#

Command: **priority-flowcontrol**

Description: Configure Priority Flow Control (PFC per IEEE 802.1Qbb) for an Interface.

Syntax: **priority-flowcontrol** prio <prio>

Parameters: prio Traffic priority Flow Control.
<0~7> Specify range of priorities

Example:

```
SISPM1040-3248-L(config-if)# priority-flowcontrol prio 4
SISPM1040-3248-L(config-if)#
```

Command: **ptp**

Description: Configure Precision Time Protocol (1588) for an Interface.

Syntax: **ptp** <clockinst> [internal]

ptp <clockinst> announce { [interval <interval> | stop | default] } [timeout <timeout>]]*1

ptp <clockinst> delay-asymmetry <delay_asymmetry>

ptp <clockinst> delay-mechanism { e2e | p2p }

ptp <clockinst> delay-req interval { <interval> | stop | default }

ptp <clockinst> egress-latency <egress_latency>

ptp <clockinst> ingress-latency <ingress_latency>

ptp <clockinst> localpriority <localpriority>

ptp <clockinst> mcast-dest { default | link-local }

ptp <clockinst> not-slave

ptp <clockinst> sync-interval { <interval> | stop | default }

ptp <clockinst> two-step [true]

ptp <clockinst> two-step false

ptp pps-delay { { auto master-port interface <port_type> <v_port_type_id> } | { man cable-delay <cable_delay> } }

ptp pps-sync { main-auto | main-man | sub } [pps-phase <pps_phase>] [cable-asy <cable_asy>] [ser-man | ser-auto]

Parameters: <0-3> [0-3] Clock instance
 announce Set announce interval and timeout
 delay-asymmetry Set path delay asymmetry
 delay-mechanism Set delay mechanism
 delay-req Set pdelay req interval
 egress-latency Set port egress latency
 ingress-latency Set port ingress latency
 internal enable as an internal interface
 localpriority Local priority pr port for G8275.1 BMC algorithm (1 is highest priority)
 mcast-dest Set multicast destination address type for the port
 not-slave set 'not-slave' attribute for G8275.1 BMC algorithm
 sync-interval Set sync interval
 two-step Set the two-step override value for the port to true
 interval Set announce interval

timeout	Set Announce timeout
<-3-4>	LogAnnounceInterval
<1-10>	Announce timeout (* announce interval)
<-100000-100000>	Delay asymmetry in ns.
E2e	End to End Delay mechanism
p2p	Peer to Peer Delay mechanism
interval	Define pdelay req interval
<-7-5>	logMinPdelayReqInterval
<-7-5>	logMinPdelayReqInterval
<-100000-100000>	Egress latency in ns
ingress-latency	internal
ingress-latency	internal
<-100000-100000>	Ingress latency in ns
<1-255>	PTP clock priority1: range = 1-255
default	Default destination address
link-local	Link-local destination address
<-7-4>	logSyncInterval
false	
true	

Example:

```
SISPM1040-3248-L(config-if)# ptp 0 not-slave
Error setting port data instance 0 port 8
SISPM1040-3248-L(config-if)# ptp 0 not-slave
SISPM1040-3248-L(config-if)# ptp
E basics 23:20:53 241/thread_os_prio_get#641: Error: getpriority(240): No such process
SISPM1040-3166-L(config-if)# ptp 0 announce interval -1 timeout 5
Error setting port data instance 0 port 1
```

Message: Error getting port data instance 0 port 6. Error setting port data instance 0 port 1.

Command: **pvlan**

Description: Configure Private VLAN for an interface.

Syntax: **pvlan** <pvlan_list>
pvlan isolation

Parameters: <range_list> list of PVLANS. Range is from 1 to number of ports.
Isolation Port isolation

Example:

```
SISPM1040-3248-L(config-if)# pvlan 8
SISPM1040-3248-L(config-if)# pvlan isolation
SISPM1040-3248-L(config-if)#
```

trust	Trust configuration
wred-group	WRED group configuration
wrr	Weighted round robin configuration
<0-7>	Specific class of service ID
<0-7>	Specific class of service
<0-1>	Specific Drop Eligible Indicator
<0-3>	Specific drop precedence level
any	Classify to new DSCP always
selected	Classify to new DSCP if classify is enabled for specific DSCP value in global DSCP classify map
zero	Classify to new DSCP if DSCP is 0
remap	Rewrite DSCP field using classified DSCP remapped through global dscp-egress-translation map
rewrite	Rewrite DSCP field with classified DSCP value (no translation)
<0-511>	Map ID (Egress)
<0-255>	Map ID (Ingress)
cos-tag	Map for cos to tag configuration
tag-cos	Map for tag to cos configuration
<0-7>	Specific Priority Code Point (PCP)
<1-13128147>	Policer rate (default kbps). Internally rounded up to the nearest value supported by the port policer.
Flowcontrol	Enable flow control
fps	Unit is frames per second
kbps	Unit is kilobits per second (default)
kfps	Unit is kiloframes per second
mbps	Unit is Megabits per second
queue	Specify queue
<0~7>	Specific queue or range
<1-13128147>	Policer rate (default kbps). Internally rounded up to the nearest value supported by the queue policer.
Kbps	Unit is kilobits per second (default)
mbps	Unit is Megabits per second
queue	Specify queue
<0~7>	Specific queue or range
<1-13107100>	Shaper rate (default kbps). Internally rounded up to the nearest value supported by the queue shaper.
Kbps	Unit is kilobits per second (default)
mbps	Unit is Megabits per second
rate-type	Setup shaping rate type
broadcast	Police broadcast frames
unicast	Police unicast frames
unknown	Police unknown (flooded) frames

<1-13128147>	Policer rate (default kbps). Internally rounded up to the nearest value supported by the storm policer. Supported rates are divisible by 10 fps or 25 kbps.
Mapped	Used mapped values (COS, DPL -> PCP, DEI)
pcp	Specify default PCP
dscp	DSCP value
tag	VLAN tag
<1-3>	Specific WRED group
<1-100>	Weight for queue 0 – 7

Example:

```

SISPM1040-3248-L(config-if)# qos class 5
SISPM1040-3248-L(config-if)# qos cos 7
SISPM1040-3248-L(config-if)# qos dei 0
SISPM1040-3248-L(config-if)# qos dpl 1
SISPM1040-3248-L(config-if)# qos dscp-classify any
SISPM1040-3248-L(config-if)# qos dscp-remark rewrite
SISPM1040-3248-L(config-if)# qos dscp-translate
SISPM1040-3248-L(config-if)# qos egress-map 200
SISPM1040-3248-L(config-if)# qos ingress-map 100
SISPM1040-3248-L(config-if)# qos policer 5000 flowcontrol fps
SISPM1040-3248-L(config-if)# qos policer 5000 flowcontrol fps
SISPM1040-3248-L(config-if)# qos queue-policer q 6 60000
SISPM1040-3248-L(config-if)# qos queue-shaper queue 3 70000
SISPM1040-3248-L(config-if)# qos shaper 900000
SISPM1040-3248-L(config-if)# qos storm broadcast 700000
SISPM1040-3248-L(config-if)# qos tag-remark mapped
SISPM1040-3248-L(config-if)# qos trust dscp
SISPM1040-3248-L(config-if)# qos trust tag
SISPM1040-3248-L(config-if)# qos wred 1
SISPM1040-3248-L(config-if)# qos wrr 25 30 40
SISPM1040-3248-L(config-if)#

```

Command: **rmon**

Description: Configure Remote Monitoring on an interface.

Syntax: **rmon** collection history <id> [buckets <buckets>] [interval <interval>]
rmon collection stats <id>

Parameters:

history	Configure history
stats	Configure statistics
collection	Configure Remote Monitoring Collection on an interface
<1-65535>	History entry ID
buckets	Requested buckets of intervals. Default is 50 buckets
interval	Interval to sample data for each bucket. Default is 1800 seconds
<1-65535>	Requested buckets of intervals
interval	Interval to sample data for each bucket. Default is 1800 seconds
<1-3600>	Interval in seconds to sample data for each bucket
<cr>	

Example:

```
SISPM1040-3248-L(config-if)# rmon collection history 200 buckets 50000 interval 360
SISPM1040-3248-L(config-if)# rmon collection stats 200
SISPM1040-3248-L(config-if)# rmon collection stats 1
SISPM1040-3248-L(config-if)#
```

Command: **sflow**

Description: Configure Statistics flow for an interface.

Syntax: **sflow** [< sampler_idx_list >]
sflow counter-poll-interval [sampler < sampler_idx_list >] [< poll_interval >]
sflow max-sampling-size [sampler < sampler_idx_list >] [< max_sampling_size >]
sflow sampler-type [sampler < sampler_idx_list >] { rx | tx | all }
sflow sampling-rate [sampler < sampler_idx_list >] [< sampling_rate >]

Parameters:

counter-poll-interval	The interval – in seconds – between counter poller samples.
Max-sampling-size	Specifies the maximum number of bytes to transmit per flow sample. To have room for any frame, the maximum datagram size should be roughly 100 bytes larger than the maximum header size.
Sampler-type	Specifies the types of flow sample (all, tx, rx).
Sampling-rate	Specifies the statistical sampling rate. The sample rate is specified as N to sample 1/Nth of the packets in the monitored flows. There are no restrictions on the value, but the switch will adjust it to the closest possible sampling rate.
<1-3600>	interval in seconds
<14-200>	sampling size in bytes
<1-4294967295>	Sampling rate

Example:

```
SISPM1040-3248-L(config-if)# sflow
SISPM1040-3248-L(config-if)# sflow max-sampling-size
SISPM1040-3248-L(config-if)# sflow sampler-type tx
SISPM1040-3248-L(config-if)# sflow sampling-rate 600000
SISPM1040-3248-L(config-if)#
```

Command: **shutdown**

Description: Disables the interface.

Syntax: **shutdown** <cr>

Parameters: None.

Example:

```
SISPM1040-3248-L(config-if)# shutdown
SISPM1040-3248-L(config-if)#
```

Command: `spanning-tree`

Description: Configure Spanning Tree protocol for an interface.

Syntax:

- `spanning-tree`
- `spanning-tree auto-edge`
- `spanning-tree bpdu-guard`
- `spanning-tree edge`
- `spanning-tree link-type { point-to-point | shared | auto }`
- `spanning-tree mst <instance> cost { <cost> | auto }`
- `spanning-tree mst <instance> port-priority <prio>`
- `spanning-tree restricted-role`
- `spanning-tree restricted-tcn`
- `spanning-tree root-guard`

Parameters:	<code>auto-edge</code>	Auto detect edge status
	<code>bpdu-guard</code>	Enable/disable BPDU guard
	<code>edge</code>	Edge port
	<code>link-type</code>	Port link-type
	<code>mst</code>	STP bridge instance
	<code>restricted-role</code>	Port role is restricted (never root port)
	<code>restricted-tcn</code>	Restrict topology change notifications
	<code>root-guard</code>	Enable/disable root guard
	<code>auto</code>	Auto detect
	<code>point-to-point</code>	Forced to point-to-point
	<code>shared</code>	Forced to Shared
	<code><0-7></code>	instance (CIST=0, MST11=1...)
	<code>cost</code>	STP Cost of this port
	<code>port-priority</code>	STP priority of this port
	<code><1-200000000></code>	Cost range
	<code>auto</code>	Use auto cost

Example:

```
SISPM1040-3248-L(config-if)# spanning-tree auto-edge
SISPM1040-3248-L(config-if)# spanning-tree bpdu-guard
SISPM1040-3248-L(config-if)# spanning-tree edge
SISPM1040-3248-L(config-if)# spanning-tree root-guard
SISPM1040-3248-L(config-if)# spanning-tree mst 0 cost
SISPM1040-3248-L(config-if)# spanning-tree restricted-role
SISPM1040-3248-L(config-if)# spanning-tree restricted-tcn
SISPM1040-3248-L(config-if)# spanning-tree root-guard
50000SISPM1040-3248-L(config-if)#
```

Command: speed

Description: Configure interface speed for an Interface. If you use 10, 100, or 1000 keywords with the auto keyword the port will only advertise the specified speeds.

Syntax:

```
speed { 10g | <has_speed_2g5> | <has_speed_1g> | <has_speed_100m> | <has_speed_10m> | auto { [ <has_neg_10> ] [ <has_neg_100> ] [ <has_neg_1000> ] [ 10g ] } }
```

Parameters:	10g	10Gbps
	<1000>	1Gbps
	<100>	100Mbps
	<10>	10Mbps
	auto	Auto negotiation

Example:

```
SISPM1040-3248-L(config-if)# speed auto
SISPM1040-3248-L(config-if)# speed 10
GigabitEthernet 1/25 does not support this mode/speed
GigabitEthernet 1/26 does not support this mode/speed
GigabitEthernet 1/27 does not support this mode/speed
GigabitEthernet 1/28 does not support this mode/speed
10GigabitEthernet 1/1 does not support this mode/speed
10GigabitEthernet 1/2 does not support this mode/speed
10GigabitEthernet 1/3 does not support this mode/speed
10GigabitEthernet 1/4 does not support this mode/speed
SISPM1040-3248-L(config-if)# speed 10G
GigabitEthernet 1/1 does not support this mode/speed
GigabitEthernet 1/2 does not support this mode/speed
GigabitEthernet 1/3 does not support this mode/speed
GigabitEthernet 1/4 does not support this mode/speed
GigabitEthernet 1/5 does not support this mode/speed
GigabitEthernet 1/6 does not support this mode/speed
GigabitEthernet 1/7 does not support this mode/speed
GigabitEthernet 1/8 does not support this mode/speed
GigabitEthernet 1/9 does not support this mode/speed
GigabitEthernet 1/10 does not support this mode/speed
GigabitEthernet 1/11 does not support this mode/speed
GigabitEthernet 1/12 does not support this mode/speed
GigabitEthernet 1/13 does not support this mode/speed
GigabitEthernet 1/14 does not support this mode/speed
GigabitEthernet 1/15 does not support this mode/speed
GigabitEthernet 1/16 does not support this mode/speed
GigabitEthernet 1/17 does not support this mode/speed
GigabitEthernet 1/18 does not support this mode/speed
GigabitEthernet 1/19 does not support this mode/speed
GigabitEthernet 1/20 does not support this mode/speed
GigabitEthernet 1/21 does not support this mode/speed
GigabitEthernet 1/22 does not support this mode/speed
SISPM1040-3248-L(config-if)#
```

Command: **switchport**

Description: Set VLAN switching mode characteristics of the interface.

Syntax:

```

switchport access vlan <pvid>
switchport forbidden vlan { add | remove } <vlan_list>
switchport hybrid acceptable-frame-type { all | tagged | untagged }
switchport hybrid allowed vlan { all | none | [ add | remove | except ] <vlan_list> }
switchport hybrid egress-tag { none | all [ except-native ] }
switchport hybrid ingress-filtering
switchport hybrid native vlan <pvid>
switchport hybrid port-type { unaware | c-port | s-port | s-custom-port }
switchport mode { access | trunk | hybrid }
switchport trunk allowed vlan { all | none | [ add | remove | except ] <vlan_list> }
switchport trunk native vlan <pvid>
switchport trunk vlan tag native
switchport vlan ip-subnet [ id <1-128> ] <ipv4> vlan <vid>
switchport vlan mac <mac_addr> vlan <vid>
switchport vlan mapping <gid>
switchport vlan protocol group <grp_id> vlan <vid>
switchport voice vlan discovery-protocol { oui | lldp | both }
switchport voice vlan mode { auto | force | disable }
switchport voice vlan security

```

Parameters:

access	Set access mode characteristics of the interface
forbidden	Adds or removes forbidden VLANs from the current list of forbidden VLANs
hybrid	Change PVID for hybrid port
mode	Set mode of the interface
trunk	Change PVID for trunk port
vlan	VLAN commands
voice	Voice appliance attributes
<vlan_id>	VLAN ID of the VLAN when this port is in access mode
access	Set mode to ACCESS unconditionally
hybrid	Set mode to HYBRID unconditionally
trunk	Set mode to TRUNK unconditionally
vlan	Set VLAN when interface is in access mode
<vlan_id>	VLAN ID of the VLAN when this port is in access mode
vlan	VLAN for voice traffic
discovery-protocol	Set Voice VLAN port discovery protocol
mode	Set Voice VLAN port mode
security	Enable Voice VLAN port security mode
both	Detect telephony device by OUI address and LLDP
lldp	Detect telephony device by LLDP
oui	Detect telephony device by OUI address
auto	Enable auto detect mode

disable	disjoin Voice VLAN
force	Force to join Voice VLAN
<1-32>	Group id
<ipv4_subnet>	Source IP address and mask (Format: xx.xx.xx.xx/mm.mm.mm.mm).
id	Specify an index for the IP subnet entry (deprecated).
<1-128>	The index of the IP subnet entry (deprecated).
<mac_ucast>	48 bit unicast MAC address: xx:xx:xx:xx:xx:xx
vlan	Add or modify VLAN entry in forbidden table.
Add	Add to existing list.
Remove	Remove from existing list.
<vlan_list>	VLAN IDs
acceptable-frame-type	Set acceptable frame type on a port
allowed	Set allowed VLAN characteristics when interface is in hybrid mode
egress-tag	Egress VLAN tagging configuration
ingress-filtering	VLAN Ingress filter configuration
native	Set native VLAN
port-type	Set port type
all	Allow all frames
tagged	Allow only tagged frames
untagged	Allow only untagged frames
vlan	Set allowed VLANs when interface is in hybrid mode
<vlan_list>	VLAN IDs of the allowed VLANs when this port is in hybrid mode
add	Add VLANs to the current list
all	All VLANs
except	All VLANs except the following
none	No VLANs
remove	Remove VLANs from the current list
allowed	Set allowed VLAN characteristics when interface is in trunk mode
native	Set native VLAN
vlan	VLAN commands
<vlan_list>	VLAN IDs of the allowed VLANs when this port is in trunk mode
ip-subnet	VCL IP Subnet-based VLAN configuration.
Mac	MAC-based VLAN commands
mapping	Maps an interface to a VLAN translation group.
Protocol	Protocol-based VLAN commands
<ipv4_subnet>	Source IP address and mask (Format: xx.xx.xx.xx/mm.mm.mm.mm).
id	Specify an index for the IP subnet entry (deprecated).
<1-128>	The index of the IP subnet entry (deprecated).
<mac_ucast>	48 bit unicast MAC address: xx:xx:xx:xx:xx:xx
<1-32>	Group id
group	Protocol-based VLAN group commands
<word16>	Group Name (Range: 1 – 16 characters)
vlan	VLAN keyword

<vlan_id>	VLAN ID required for the group to VLAN mapping (Range: 1-4094)
vlan	VLAN for voice traffic
discovery-protocol	Set Voice VLAN port discovery protocol
mode	Set Voice VLAN port mode
security	Enable Voice VLAN port security mode
both	Detect telephony device by OUI address and LLDP
lldp	Detect telephony device by LLDP
oui	Detect telephony device by OUI address

Example:

```
SISPM1040-3248-L(config-if)# switchport voice vlan mode auto
SISPM1040-3248-L(config-if)# switchport access vlan 10
SISPM1040-3248-L(config-if)# switchport vlan mapping 1
SISPM1040-3248-L(config-if)# switchport forbidden vlan add 1000
SISPM1040-3248-L(config-if)# switchport forbidden vlan remove 100
SISPM1040-3248-L(config-if)# switchport hybrid acceptable-frame-type all
SISPM1040-3248-L(config-if)# switchport hybrid allowed vlan all
SISPM1040-3248-L(config-if)# switchport vlan mapping 1
SISPM1040-3248-L(config-if)# switchport vlan protocol group SwVP11 vlan 2000
SISPM1040-3248-L(config-if)# switchport voice vlan discovery-protocol oui
SISPM1040-3248-L(config-if)# switchport voice vlan security
SISPM1040-3248-L(config-if)#
```

Command: **udld**

Description: UDLD configuration on the interface

Syntax: **udld** port [aggressive] [message time-interval <v_interval>]

Parameters:

port UDLD configuration on the interface

aggressive Enable UDLD in the aggressive mode on an interface

message Configures the period of time between UDLD probe messages on ports that are in the advertisement phase and are determined to be bidirectional. The range is from 7 to 90 seconds. (Currently default message time interval 7 seconds is supported).

<7-90> time-interval. Configures the period of time between UDLD probe messages on ports that are in the advertisement phase and are determined to be bidirectional. The range is from 7 to 90 seconds (Currently default message time interval 7 seconds is supported).

Example:

```
SISPM1040-3248-L(config-if)# udld port aggressive message time-interval 20
SISPM1040-3248-L(config-if)# udld port <cr>
SISPM1040-3248-L(config-if)#
```

Command: **interface llag**

Description: Configure local Link Aggregation for a selected interface.

Syntax: **interface** (<port_type> [<plist>])
do <command>
end
exit
help
lACP failover { revertive | non-revertive }
lACP max-bundle <v_uint>
no lACP failover [revertive | non-revertive]
no lACP max-bundle [<'1'-'AGGR_MGMT_LAG_PORTS_MAX_'>]

Parameters: **1-16** ID of LLAG interface
do To run exec commands in the configuration mode
end Go back to EXEC mode
exit Exit from current mode
help Description of the interactive help system
lACP Link Aggregation Control Protocol
no Negate
failover LACP Failover
max-bundle LACP Max. bundle
non-revertive Failover mode is non-revertive
revertive Failover mode is revertive
1-16 LACP maximum bundle

Example:

```
SISPM1040-3248-L(config)# interface llag ?
  1-16  ID of LLAG interface
SISPM1040-3248-L(config-llag)# lACP ?
  failover
  max-bundle
SISPM1040-3248-L(config-llag)# lACP failover ?
  non-revertive
  revertive
SISPM1040-3248-L(config-llag)# lACP failover revertive
SISPM1040-3248-L(config-llag)# lACP max-bundle 1
SISPM1040-3248-L(config-llag)# exit
SISPM1040-3248-L(config)#
```

Command: **interface vlan**

Description: Configure VLAN interface parameters for a selected interface.

Syntax: <command>

end

exit

help

ip address { { <address> <netmask> } | { dhcp [fallback <fallback_address> <fallback_netmask> [timeout <fallback_timeout>]] [client-id { <port_type> <client_id_interface> | ascii <ascii_str> | hex <hex_str> }] [hostname <hostname>] } }

ip igmp snooping

ip igmp snooping compatibility { auto | v1 | v2 | v3 }

ip igmp snooping last-member-query-interval <ipmc_lmqi>

ip igmp snooping priority <cos_priority>

ip igmp snooping querier { election | address <v_ipv4_ucast> }

ip igmp snooping query-interval <ipmc_qi>

ip igmp snooping query-max-response-time <ipmc_qri>

ip igmp snooping robustness-variable <ipmc_rv>

ip igmp snooping unsolicited-report-interval <ipmc_uri>

ipv6 address <subnet>

ipv6 address { autoconfig | dhcp [rapid-commit] }

ipv6 mld snooping

ipv6 mld snooping compatibility { auto | v1 | v2 }

ipv6 mld snooping last-member-query-interval <ipmc_lmqi>

ipv6 mld snooping priority <cos_priority>

ipv6 mld snooping querier election

ipv6 mld snooping query-interval <ipmc_qi>

ipv6 mld snooping query-max-response-time <ipmc_qri>

ipv6 mld snooping robustness-variable <ipmc_rv>

ipv6 mld snooping unsolicited-report-interval <ipmc_uri>

no ip address

no ip igmp snooping

no ip igmp snooping compatibility

no ip igmp snooping last-member-query-interval

no ip igmp snooping priority

no ip igmp snooping querier { election | address }

no ip igmp snooping query-interval

no ip igmp snooping query-max-response-time

no ip igmp snooping robustness-variable

no ip igmp snooping unsolicited-report-interval

no ipv6 address [<ipv6_subnet>]

no ipv6 address { autoconfig | dhcp [rapid-commit] }

no ipv6 mld snooping

no ipv6 mld snooping compatibility

```
no ipv6 mld snooping last-member-query-interval
no ipv6 mld snooping priority
no ipv6 mld snooping querier election
no ipv6 mld snooping query-interval
no ipv6 mld snooping query-max-response-time
no ipv6 mld snooping robustness-variable
no ipv6 mld snooping unsolicited-report-interval
```

Parameters:

<vlan_list>	List of VLAN interface numbers
do	To run exec commands in the configuration mode
end	Go back to EXEC mode
exit	Exit from current mode
help	Description of the interactive help system
ip	Ipv4 configuration
ipv6	Ipv6 configuration commands
no	Negate a command or set its defaults
address	Address configuration
igmp	Internet Group Management Protocol
<ipv4_addr>	IP address
dhcp	Enable DHCP
snooping	Snooping IGMP
compatibility	Interface compatibility
last-member-query-interval	Last Member Query Interval in tenths of seconds
priority	Interface CoS priority
querier	IGMP Querier configuration
query-interval	Query Interval in seconds
query-max-response-time	Query Response Interval in tenths of seconds
robustness-variable	Robustness Variable
unsolicited-report-interval	Unsolicited Report Interval in seconds
authentication	Enable authentication
authentication-key	Configure simple password authentication
retransmit-interval	Set the retransmit-interval value for the specific interface. It's the time interval (in seconds) to wait before retransmitting a database description packet or a link-state request when it has not been acknowledged.
address	mld
address	Configure the Ipv6 address of an interface
mld	Multicast Listener Discovery
<ipv6_subnet>	Ipv6 prefix x:x::y/z
dhcp	Enable DHCPv6 client function

Example 1:

```
SISPM1040-3248-L(config)# interface vlan?
Interface vlan <vlist>
SISPM1040-3248-L(config)# interface vlan 10
```

```

SISPM1040-3248-L(config-if-vlan)# ip ?
    address    Address configuration
    igmp       Internet Group Management Protocol
SISPM1040-3248-L(config-if-vlan)# ip address ?
    <ipv4_addr>  IP address
    dhcp        Enable DHCP
SISPM1040-3248-L(config-if-vlan)# ip igmp ?
    snooping    Snooping IGMP
SISPM1040-3248-L(config-if-vlan)# ipv6 ?
    address    Configure the Ipv6 address of an interface
    mld        Multicast Listener Discovery
SISPM1040-3248-L(config-if-vlan)# ipv6 address ?
    <ipv6_subnet>  Ipv6 prefix x:x::y/z
    dhcp        Enable DHCPv6 client function
SISPM1040-3248-L(config-if-vlan)# ipv6 mld ?
    snooping    Snooping MLD
SISPM1040-3248-L(config-if-vlan)#

```

Example 2:

```

SISPM1040-3248-L(config-if-vlan)# ip address dhcp fallback ?
    <ipv4_addr>  DHCP fallback address
SISPM1040-3248-L(config-if-vlan)# ip address dhcp fallback 192.168.1.44 ?
    <ipv4_netmask>  DHCP fallback netmask
SISPM1040-3248-L(config-if-vlan)# $ dhcp fallback 192.168.1.44 255.255.255.0 ?
    client-id    DHCP client identifier
    hostname     DHCP host name
    timeout      DHCP fallback timeout, Default value is 60 seconds
    <cr>
SISPM1040-3248-L(config-if-vlan)# ip address 192.168.1.30 255.255.255.0
% Failed to add Ipv4 address to VLAN = 10 (Address conflict).
SISPM1040-3248-L(config-if-vlan)#

```

Example 3:

```

SISPM1040-3248-L(config-if-vlan)# ip address dhcp ?
    client-id    DHCP client identifier
    fallback     DHCP fallback settings
    hostname     DHCP host name
    <cr>
SISPM1040-3248-L(config-if-vlan)# ip address dhcp?
    Dhcp        Enable DHCP
    <cr>
SISPM1040-3248-L(config-if-vlan)# ip address dhcp??
Ip address { { <address> <netmask> } | { dhcp [ fallback <fallback_address> <fal
lback_netmask> [ timeout <fallback_timeout> ] ] [ client-id { <port_type> <clien
t_id_interface> | ascii <ascii_str> | hex <hex_str> } ] [ hostname <hostname> ]
} }
SISPM1040-3248-L(config-if-vlan)# ip address dhcp
client-id fallback hostname <cr>
SISPM1040-3248-L(config-if-vlan)# ip address dhcp client-id ascii testtest
SISPM1040-3248-L(config-if-vlan)#

```

Chapter 7 Copy Commands

Command: `copy`

Description: Copy from source to destination.

Syntax:

```
copy { startup-config | running-config | <source_path> } { startup-config | running-config | <destination_path> }
[ syntax-check ] [ save-host-key ] [ ftp-active ] [ { merge | replace } ]
```

Parameters:

<url_file> File in FLASH or on remote server. Syntax:

```
<flash:filename> | <protocol>://[<username>[:<password>]@]<host>[:<port>][/<path>].
```

A valid file name is a text string drawn from alphabet (A-Za-z), digits (0-9), dot (.), hyphen (-), under score (_). The maximum length is 255 and hyphen must not be first character. The file name content that only contains '.' is not allowed.

Running-config Currently running configuration.

Startup-config Startup configuration.

| Output modifiers

merge merge source file with running-config

replace replace running-config with source file, default action

syntax-check Perform syntax check on source configuration

<cr>

Example:

```
SISPM1040-3248-L# copy running-config startup-config merge
Building configuration...
% Saving 3010 bytes to flash:startup-config
SISPM1040-3248-L#
SISPM1040-3248-L# copy startup-config running-config
,Disconnected>
```

Messages:

% startup-config: Load failed: Cannot read file status.

Select error: Interrupted system call

Messages:

```
SISPM1040-3248-L# copy startup-config running-config syntax-check
% Error in file startup-config, line 41:

ip source binding interface GigabitEthernet 1/2 10 192.168.1.77 11-22-33-44-55-
                                     ^
66

% Invalid word detected at '^' marker.

% Error in file startup-config, line 42:

ip source binding interface GigabitEthernet 1/3 20 192.168.1.77 11-22-33-44-55-
                                     ^
77

% Invalid word detected at '^' marker.

% Error in file startup-config, line 43:

ip source binding interface GigabitEthernet 1/4 30 192.168.1.77 11-22-33-44-55-
                                     ^
88

% Invalid word detected at '^' marker.

% Syntax check done, 3 problems found.
% Configuration aborted.
SISPM1040-3248-L#
```

Chapter 8 Delete Commands

Command: `delete`

Description: Delete one file in flash: file system.

Syntax: `delete <path>`

Parameters:

`<url_file>` File in FLASH. Syntax: `<flash:filename>`. A valid file name is a text string drawn from alphabet (A-Za-z), digits (0-9), dot (.), hyphen (-), and under score (_). The maximum length is 63 and a hyphen must not be first character. A file name that only contains '.' is not allowed.

Example:

```
SISPM1040-3248-L# delete ?
  <url_file>   File in FLASH. Syntax: <flash:filename>. A valid file name is
               a text string drawn from alphabet (A-Za-z), digits (0-9), dot
               (.), hyphen (-), under score (_). The maximum length is 63
               and hyphen must not be first character. The file name content
               that only contains '.' is not allowed.
SISPM1040-3248-L# delete?
  Delete      Delete one file in flash: file system
SISPM1040-3248-L# delete?
Delete <path>
SISPM1040-3248-L#
```

Messages: `% text.txt: Delete failed: Cannot access file.`

Chapter 9 Dir Commands

Command: `dir`

Description: Show Directory of all files in flash: file system.

Syntax: `dir <cr>`

Parameters: | Output modifiers
 <cr>
 dir Directory of all files in flash: file system

Example:

```
SISPM1040-3248-L# dir
Directory of flash:
  r- 2018-07-26 09:58:05      650 default-config
  rw 2016-01-01 00:00:47    56122 crashfile
  rw 2016-01-01 00:55:59     1984 startup-config
  rw 2016-01-01 00:13:05     8419 web_01
  rw 2016-01-01 00:13:05     8419 web_02
  rw 2016-01-01 00:13:05     2898 web_03
  rw 2016-01-01 00:13:05      169 web_04
  rw 2016-01-01 00:13:05      102 webiconlist
8 files, 78763 bytes total.
```

Flash size: 3284992 bytes (3.1 MiB)

Flash free: 3215360 bytes (3.1 MiB)

SISPM1040-3248-L#

```
SISPM1040-3166-L# dir
Directory of flash:
  r- 2019-05-07 13:24:57      650 default-config
  rw 2016-01-01 00:03:35    70931 crashfile
  rw 2016-01-01 00:13:52      207 icon_list
  rw 2016-01-01 00:04:49     8419 web_01
  rw 2016-01-01 00:04:49     8419 web_02
  rw 2016-01-01 00:04:49     2898 web_03
  rw 2016-01-01 00:04:49      169 web_04
  rw 2016-01-01 00:04:49      102 webiconlist
8 files, 91795 bytes total.
```

Flash size: 3284992 bytes (3.1 MiB)

Flash free: 3117056 bytes (3.0 MiB)

SISPM1040-3166-L#

Chapter 10 Disable Commands

Command: `disable`

Description: Turn off privileged commands.

Syntax: `disable <cr>`

Parameters: `<0-15>`
`<cr>`
`[<new_priv>]`

Example:

```
SISPM1040-3248-L> disable 1
% New privilege level must be less than current privilege level
SISPM1040-3248-L> disable 0
SISPM1040-3248-L> ?
  clear          Clear
  disable       Turn off privileged commands
  do            To run exec commands in the configuration mode
  enable       Turn on privileged commands
  exit         Exit from EXEC mode
  help        Description of the interactive help system
  iperf       network bandwidth measurement tool
  iperf3      network bandwidth measurement tool
  logout      Exit from EXEC mode
  ping        Send ICMP echo messages
  show        Display statistics counters.
  Traceroute  Send IP Traceroute messages
SISPM1040-3248-L>
```

Chapter 11 Do Commands

Command: do

Description: To run exec commands in the Config mode or Interface Config mode.

Syntax: do <command>

Parameters: LINE Exec Command

Example:

```
SISPM1040-3248-L(config)# do show version brief
Version      : SISPM1040-3248-L (standalone) v8.50.0149
Build Date   : 2024-06-02T09:29:35+08:00
SISPM1040-3248-L(config)# interface *
SISPM1040-3248-L(config-if)# do show version brief
Version      : SISPM1040-3248-L (standalone) v8.50.0149
Build Date   : 2024-06-02T09:29:35+08:00
SISPM1040-3248-L(config-if)# do show ip interface brief
Interface Address          Method  Status
-----
VLAN 1      192.168.1.77/24      Manual  UP
SISPM1040-3248-L(config-if)#
```

Chapter 12 Dot1x Commands

Command: `dot1x initialize`

Description: IEEE Standard for port-based Network Access Control. **Note** that there are Exec mode, Config mode, and Interface Config mode `dot1x` commands.

Exec mode: Force re-authentication immediately.

Config mode: Globally enable/disable/configure dot1x features.

Interface Config mode:

Syntax: `dot1x initialize [interface (<port_type> [<plist>])]`
`dot1x authentication timer inactivity <v_10_to_100000>`
`dot1x authentication timer re-authenticate <v_1_to_3600>`
`dot1x feature { [guest-vlan] [radius-qos] [radius-vlan] }*1`
`dot1x guest-vlan <value>`
`dot1x guest-vlan supplicant`
`dot1x max-reauth-req <value>`
`dot1x re-authentication`
`dot1x system-auth-control`
`dot1x timeout quiet-period <v_10_to_1000000>`
`dot1x timeout tx-period <v_1_to_65535>`

Parameters:

initialize	Force re-authentication immediately
interface	Interface
initialize	Force re-authentication immediately
<cr>	
*	All switches or All ports
GigabitEthernet	1 Gigabit Ethernet Port
10GigabitEthernet	10 Gigabit Ethernet Port
authentication	Authentication
feature	Globally enables/disables a dot1x feature functionality
guest-vlan	Guest VLAN
max-reauth-req	The number of times a Request Identity EAPOL frame is sent without response before considering entering the Guest VLAN
re-authentication	Set Re-authentication state
system-auth-control	Set the global NAS state
timeout	timeout
timer	imer
inactivity	Time in seconds between check for activity on successfully authenticated MAC addresses.
re-authenticate	The period between re-authentication attempts in seconds
<10-1000000>	seconds
guest-vlan	Globally enables/disables state of guest-VLAN
radius-qos	Globally enables/disables state of RADIUS-assigned QoS.

radius-vlan	Globally enables/disables state of RADIUS-assigned VLAN.
<1-4095>	Guest VLAN ID used when entering the Guest VLAN.
supplicant	The switch remembers if an EAPOL frame has been received on the port for the life-time of the port. Once the switch considers whether to enter the Guest VLAN, it will first check if this option is enabled or disabled. If disabled (unchecked, default), the switch will only enter the Guest VLAN if an EAPOL frame has not been received on the port for the life-time of the port. If enabled (checked), the switch will consider entering the Guest VLAN even if an EAPOL frame has been received on the port for the life-time of the port.
<1-255>	number of times
quiet-period	Time in seconds before a MAC-address that failed authentication gets a new authentication chance.
tx-period	the time between EAPOL retransmissions.
<10-1000000>	seconds
<1-65535>	seconds
guest-vlan	Enables/disables guest VLAN
port-control	Sets the port security state.
radius-qos	Enables/disables per-port state of RADIUS-assigned QoS.
radius-vlan	Enables/disables per-port state of RADIUS-assigned VLAN.
re-authenticate	Refresh (restart) 802.1X authentication process.
auto	Port-based 802.1X Authentication
force-authorized	Port access is allowed
force-unauthorized	Port access is not allowed
mac-based	Switch authenticates on behalf of the client
multi	Multiple Host 802.1X Authentication
single	Single Host 802.1X Authentication

Example 1: Exec mode:

```
SISPM1040-3248-L# dot1x initialize interface * 1/1-28
SISPM1040-3248-L# dot1x initialize interface GigabitEthernet 1/1-26
```

Example 2: Config mode:

```
SISPM1040-3166-L(config)# dot1x authentication timer inactivity 5000
SISPM1040-3166-L(config)# dot1x max-reauth-req 50
SISPM1040-3166-L(config)# dot1x re-authentication
SISPM1040-3166-L(config)# dot1x system-auth-control
SISPM1040-3166-L(config)# dot1x timeout tx-period 500
SISPM1040-3166-L(config)# dot1x timeout quiet-period 5000
SISPM1040-3166-L(config)#
```

Example 3: Interface Config mode:

```
SISPM1040-3166-L(config-if)# dot1x guest-vlan
SISPM1040-3166-L(config-if)# dot1x port-control force-authorized
SISPM1040-3166-L(config-if)# dot1x port-control single
% (The 802.1X Admin State must be set to Authorized for ports that are enabled for Spanning
Tree)
SISPM1040-3166-L(config-if)# dot1x radius-qos
SISPM1040-3166-L(config-if)# dot1x radius-vlan
SISPM1040-3166-L(config-if)# dot1x re-authenticate
SISPM1040-3166-L(config-if)#
```

Chapter 13 Enable Commands

Command: **enable**

Description: Turn on privileged commands (Exec mode).
 Modify enable password parameters (Config mode).

Syntax: **enable** password [level <priv>] <password>
 enable secret { 0 | 5 } [level <priv>] <password>

Parameters: <0-15> Choose privileged level
 password Assign the privileged level clear password
 secret Assign the privileged level secret
 <word32> The UNENCRYPTED (clear-text) password
 level Set exec level password
 0 Specifies an UNENCRYPTED password will follow
 5 Specifies an ENCRYPTED secret will follow
 <1-15> Level number
 <word32> Password

Example 1: In Exec mode:

```
SISPM1040-3248-L# enable 15
SISPM1040-3248-L#
```

Example 2: In Config mode:

```
SISPM1040-3166-L(config)# enable secret 5 level 15 admin
SISPM1040-3166-L(config)# enable password admin
SISPM1040-3166-L(config)# enable password level 15 admin
SISPM1040-3166-L(config)#
```

Chapter 14 ERPS Commands

Command: **erps**

Description: Configure Ethernet Ring Protection Switching . Note that there are Exec mode, Config mode, and Interface Config mode erps commands. ERPS is defined in ITU/T G.8032. It provides fast protection and recovery switching for Ethernet traffic in a ring topology while also ensuring that the Ethernet layer remains loop-free.

Syntax:

erps <group> command { force | manual | clear } { port0 | port1 }

erps <group> guard <guard_time_ms>

erps <group> holdoff <holdoff_time_ms>

erps <group> major port0 interface <port_type> <port0> port1 interface <port_type> <port1> [interconnect]

erps <group> mep port0 sf <p0_sf> aps <p0_aps> port1 sf <p1_sf> aps <p1_aps>

erps <group> revertive <wtr_time_minutes>

erps <group> rpl { owner | neighbor } { port0 | port1 }

erps <group> sub port0 interface <port_type> <port0> { { port1 interface <port_type> <port1> } | { interconnect <major_ring_id> } } [virtual-channel]

erps <group> topology-change propagate

erps <group> version { 1 | 2 }

erps <group> vlan { none | [add | remove] <vlans> }

Parameters:	1-64	ERPS group number
	command	Administrative Command
	clear	Clear command
	force	Force command
	manual	Manual command
	port0	ERPS Port 0 interface
	port1	ERPS Port 1 interface
	1-64	ERPS group number
	guard	Guard
	holdoff	Hold-off time
	major	Major ring
	mep	MEP
	revertive	Revertive
	rpl	Ring Protection Link
	sub	Sub-ring
	topology-change	Topology Change
	version	Version
	vlan	VLAN
	0-10000	Hold-off time in ms
	port0	ERPS Port 0 interface
	port0	ERPS Port 0 interface

1-12	Wait-to-restore time in minutes
neighbor	Neighbor role
owner	Owner role
port0	ERPS Port 0 interface
propagate	Propagate
1	ERPS version 1
2	ERPS version 2
<vlan_list>	List of VLANs
add	Add to set of included VLANs
none	Do not include any VLANs
remove	Remove from set of included VLANs
<cr>	

Example 1: Exec mode:

```
SISPM1040-3166-L# erps 1 command manual port1
SISPM1040-3166-L# erps 1 command manual port0
SISPM1040-3166-L# erps 1 command clear port1
SISPM1040-3166-L# erps 1 command force port1
SISPM1040-3248-L#
```

Example 2: Config mode:

```
SISPM1040-3166-L(config)# erps 1 guard 400
SISPM1040-3166-L(config)# erps 1 holdoff 500
SISPM1040-3166-L(config)# erps 1 mep port0 sf 1 aps 2 port1 sf 750 aps 990
SISPM1040-3166-L(config)# erps 1 revertive 4
SISPM1040-3166-L(config)# erps 1 rpl owner port0
SISPM1040-3166-L(config)# erps 1 version 2
SISPM1040-3166-L(config)#
```

Messages:

% ERPS group 1: Generic error occurred

% ERPS group 1: Given protection group does not exist

% ERPS group 1: This node is RPL owner for given protection group

% ERPS group 1: Given protection group already created

% ERPS group 1: Maximum number of VLANs already configured for protection group

Chapter 15 Firmware Commands

Command: `firmware`

Description: Firmware upgrade/swap.

Syntax: `firmware swap`
`firmware upgrade <url_file> [save-host-key] [ftp-active]`

Parameters:

`swap` Swap between Active and Backup firmware image.

`upgrade` Firmware upgrade

`<url_file>` Uniform Resource Locator. It is a specific character string that constitutes a reference to a resource. Syntax:

```
<protocol>://[<username>[:<password>]@]<host>[:<port>][/<path>]/<file_name>
```

If the following special characters: space !"#%&'()*+,-/;:<=>?@[\\]^`{|}~ need to be contained in the input URL string, they should be percent-encoded. A valid file name is a text string drawn from alphabet (A-Za-z), digits (0-9), dot (.), hyphen (-), under score (_). The maximum length is 63 and hyphen must not be first character. The file name content that only contains '.' is not allowed.

`save-host-key` Sve the host Key.

`ftp-active` ftp-active

Example:

```
SISPM1040-3248-L# firmware upgrade tftp://192.168.1.77/running-config
Downloading...
W firmware 00:41:15 254/execute#219: Warning: Timeout waiting for data exceeded
Download failed: Timeout
SISPM1040-3248-L# firmware swap
Alternate image activated, now rebooting.

SISPM1040-3248-L#
Username
SISPM1040-3248-L# firmware upgrade tftp://192.168.1.77/running-config
Downloading...
W firmware 00:25:23 256/execute#221: Warning: Timeout waiting for data exceeded
Download failed: Timeout
SISPM1040-3248-L#
SISPM1040-3248-L# copy startup-config sftp://buck:buck1@192.251.144.104/startup-config-
radius save-host-key
% startup-config: Load failed: Cannot read file status.
SISPM1040-3248-L#
```

Chapter 16 IP Commands

Command: `ip <command>`

Description: IP commands are available in Exec mode and in Config mode.

Exec mode: Restart DHCP client on a specified VLAN.

Config mode: Configure IP parameters.

Syntax:

`ip arp inspection`

`ip arp inspection entry interface <port_type> <in_port_type_id> <vlan_var> <mac_var> <ipv4_var>`

`ip arp inspection translate [interface <port_type> <in_port_type_id> <vlan_var> <mac_var> <ipv4_var>]`

`ip arp inspection vlan <in_vlan_list>`

`ip arp inspection vlan <in_vlan_list> logging { deny | permit | all }`

`ip dhcp relay`

`ip dhcp relay information option`

`ip dhcp relay information policy { drop | keep | replace }`

`ip dhcp retry interface vlan <vlan_id>`

`ip dhcp server per-port [vlan { <portPortVLAN> }]`

`ip dhcp snooping`

`ip dhcp vlan <vid>`

`ip dhcp vlan <vid> <start_ip> <end_ip> <lease> <mask> <gateway> <dns>`

`ip dns proxy`

`ip domain name { <v_domain_name> | dhcp [ipv4 | ipv6] [interface vlan <v_vlan_id_dhcp>] }`

`ip helper-address <v_ipv4_ucast>`

`ip http port <port>`

`ip http secure-certificate { upload <url_file> [pass-phrase <pass_phrase>] | generate }`

`ip http secure-server port <port>`

Parameters:	interface	
	vlan	VLAN interface
	<vlan_id>	VLAN ID
	arp	Address Resolution Protocol
	dhcp	Dynamic Host Configuration Protocol
	dns	Domain Name System
	domain	IP DNS Resolver
	helper-address	DHCP relay server
	http	HTTP server
	igmp	Internet Group Management Protocol
	link-local	Link-Local address binding interface
	name-server	Domain Name System

route	Add IP route
routing	Enable routing for IPv4 and IPv6
scp	Secure copy function
source	source command
ssh	Secure Shell
telnet	Telnet
verify	verify command
inspection	ARP inspection
entry	ARP inspection entry
translate	ARP inspection translate all entries
vlan	ARP inspection VLAN setting
relay	DHCP relay agent configuration
server	Enable DHCP server
snooping	DHCP snooping
vlan	VLAN interface
proxy	DNS proxy service
name	Define the default domain name
<ipv4_ucast>	IP address of the DHCP relay server
port	Service port number
secure-certificate	HTTPS certificate
secure-server	secure web server
host-proxy	IGMP proxy configuration
snooping	Snooping IGMP
ssm-range	IPv4 address range of Source Specific Multicast
unknown-flooding	Flooding unregistered IPv4 multicast traffic
interface	Select an interface to configure
<1-4>	Preference of DNS server. Default selection is 1
<ipv4_ucast>	A valid IPv4 unicast address
<ipv6_ucast>	A valid IPv6 unicast address
dhcp	Dynamic Host Configuration Protocol
<ipv4_addr>	Network
server	support scp server
binding	IP source binding
keyregen	Regenerate ssh key
port	Service port number
source	verify source
translate	IP verify source translate all entries
<vlan_id>	Set DHCP server per port VLAN

Example 1: Exec mode:

```
SISPM1040-3248-L# ip dhcp retry interface vlan 10
% Failed to restart DHCP client on VLAN = 10.
SISPM1040-3248-L#
```

Example 2: Config mode:

```
SISPM1040-3166-L(config)# ip ?
  arp          Address Resolution Protocol
  dhcp        Dynamic Host Configuration Protocol
  dns         Domain Name System
  domain      IP DNS Resolver
  helper-address DHCP relay server
  http       HTTP server
  igmp       Internet Group Management Protocol
  link-local  Link-Local address binding interface
  name-server Domain Name System
  route      Add IP route
  routing    Enable routing for IPv4 and IPv6
  scp       Secure copy function
  source     source command
  ssh       Secure Shell
  telnet    Telnet
  verify    verify command
SISPM1040-3166-L(config)# ip dhcp vlan 100
SISPM1040-3166-L(config)# ip arp inspection translate
ARP Inspection:
  Translate 0 dynamic entries into static entries.
SISPM1040-3166-L(config)# ip http secure-server port 777
SISPM1040-3166-L(config)#

SISPM1040-3248-L(config)# ip ssh keyregen
W ssh 18:45:44 140/process-daemon.cxx#235: Warning: ssh_showkey-264 STDOUT>
Public key portion is:
  521 ecdsa-sha2-nistp521 AAAAE2VjZHNhLXNoYTItbmlzdHA1MjEAAAABmlzdHA1MjEAAACFBAH
sXL+ATW5kZCHeg04/MBWhIh2/gCc4iU+gVZCuxg9zFmX0bL1KU5zTTIYysZ0ASF0SKXspy/O2zSVwzu7
UkvFRcQBWyAdPwIIk5xuxedkdGht0mATU5HZw/kAJHALizyIbPOL+jjhHzQM5zusiPXDQSN0Zpamptvx
MZMBahWD4VR8ARg==
Fingerprint: md5 fa:8b:fc:eb:18:f9:0e:d1:e6:d2:b5:19:65:be:1a:4b
SISPM1040-3248-L(config)# ip dhcp server per-port
SISPM1040-3248-L(config)# ip dhcp server per-port vlan 100
% Failed to create interface vlan 100
SISPM1040-3248-L(config)# ip dhcp server per-port vlan 1
SISPM1040-3248-L(config)#
```

Chapter 17 Iperf Commands

Command: `iperf`

Description: Set iperf network bandwidth measurement tool parameters. **iperf** is a widely used tool for network performance measurement and tuning. It is significant as a cross-platform tool that can produce standardized performance measurements for any network. Iperf has client and server functionality, and can create data streams to measure the throughput between the two ends in one or both directions. Typical Iperf output contains a time-stamped report of the amount of data transferred and the throughput measured.

Syntax : `iperf host <v_host> [port <v_port>] [time <v_time>] [interval <v_interval>] [ttl <v_ttl>]`

Parameters:

<code>host</code>	host address
<code><word1-255></code>	host address
<code>interval</code>	seconds between periodic bandwidth reports
<code>port</code>	server port
<code>time</code>	time in seconds to transmit for
<code>ttl</code>	time-to-live, for multicast
<code><1-60></code>	seconds between periodic bandwidth reports
<code><1-65535></code>	server port (default 5001)
<code><1-255></code>	time-to-live, for multicast (default 1)

Example:

```
SISPM1040-3248-L# iperf host main interval 20 port 567 time 30 ttl 3
SISPM1040-3248-L#
```

Chapter 18 Iperf3 Commands

Command: `iPerf3`

Description: Set iperf v3 network bandwidth measurement tool parameters. **iPerf3** is a tool for active measurements of the maximum achievable bandwidth on IP networks. It supports tuning of various parameters related to timing, buffers and protocols (TCP, UDP, SCTP with IPv4 and IPv6). For each test it reports the bandwidth, loss, and other parameters. This is a new implementation that shares no code with the original iPerf and also is not backwards compatible. iPerf was originally developed by NLANR/DAST. iPerf3 is principally developed by ESnet / Lawrence Berkeley National Laboratory. It is released under a three-clause BSD license. See <https://iperf.fr/>.

Syntax : `iperf3 host <v_host> [port <v_port>] [time <v_time>] [interval <v_interval>]`

Parameters:

<code>host</code>	host address
<code><word1-255></code>	host address
<code>interval</code>	seconds between periodic bandwidth reports
<code>port</code>	server port
<code>time</code>	time in seconds to transmit for
<code><1-60></code>	seconds between periodic bandwidth reports
<code><1-65535></code>	server port (default 5201)
<code><1-60></code>	time in seconds to transmit for (default 10 secs)

Example:

```
SISPM1040-3248-L# iperf3 host nman interval 50 port 9000 time 2
SISPM1040-3248-L#
```

Message: `iperf3: error - unable to connect to server: Connection refused`

Chapter 19 IPv6 Commands

Command: **ipv6**

Description: IPv6 configuration commands; available in Exec mode, Config mode, and Interface Config mode.

Syntax: **ipv6** dhcp-client restart [interface vlan <v_vlan_list>]
ipv6 mld host-proxy [leave-proxy]
ipv6 mld snooping
ipv6 mld snooping vlan <v_vlan_list>
ipv6 mld ssm-range <v_ipv6_mcast> <ipv6_prefix_length>
ipv6 mld unknown-flooding
ipv6 route <v_ipv6_subnet> { <v_ipv6_ucast> | interface vlan <v_vlan_id> <v_ipv6_addr> }
ipv6 mld snooping filter <profile_name>
ipv6 mld snooping immediate-leave
ipv6 mld snooping max-groups <throttling>
ipv6 mld snooping mrouter

Parameters:	dhcp-client	Manage DHCPv6 client service
	ipv6	IPv6 configuration commands
	restart	Restart DHCPv6 client service
	interface	Select an interface to configure
	vlan	VLAN of IPv6 interface
	<vlan_list>	IPv6 interface VLAN list
	mld	Multicast Listener Discovery
	route	Configure static routes
	host-proxy	MLD proxy configuration
	snooping	Snooping MLD
	ssm-range	IPv6 address range of Source Specific Multicast
	unknown-flooding	Flooding unregistered IPv6 multicast traffic
	vlan	MLD VLAN
	<vlan_list>	VLAN identifier (VID)
	<ipv6_subnet>	IPv6 prefix x:x::y/z
	<word16>	Profile name in 16 characters
	filter	Access control on MLD multicast group registration
	immediate-leave	Immediate leave configuration
	max-groups	MLD group throttling configuration
	mrouter	Multicast router port configuration
	<1-10>	Maximum number of MLD group registration
	<cr>	

Example 1: Exec mode:

```
SISPM1040-3248-L# ipv6 dhcp-client restart
SISPM1040-3248-L# ipv6 dhcp-client restart interface vlan 10
% Invalid DHCPv6 client interface Vlan10
SISPM1040-3248-L#
```

Example 2: Config mode:

```
SISPM1040-3166-L(config)# ipv6 mld snooping vlan 100  
% 'ipv6 mld snooping vlan <xx>' is obsolete.  
SISPM1040-3166-L(config)#
```

```
SISPM1040-3166-L(config)# ipv6 mld snooping vlan 100  
SISPM1040-3166-L(config)#
```

Example 3: Interface Config mode:

```
SISPM1040-3166-L(config-if)# ipv6 mld snooping immediate-leave  
SISPM1040-3166-L(config-if)# ipv6 mld snooping max-groups 4  
SISPM1040-3166-L(config-if)# ipv6 mld snooping mrouter  
SISPM1040-3166-L(config-if)#
```

Chapter 20 Link OAM Commands

Command: **link-oam** remote-loopback

Description: Configure remote loopback on interface. Enable or Disable (when the no keyword is entered) Link OAM on the interface.

Syntax:

link-oam

link-oam link-monitor frame { [window <error_window>] [threshold <error_threshold>] }*1

link-oam link-monitor frame-seconds { [window <error_window>] [threshold <error_threshold>] }*1

link-oam link-monitor supported

link-oam link-monitor symbol-period { [window <error_window>] [threshold <error_threshold>] }*1

link-oam mib-retrieval supported

link-oam mode { active | passive }

link-oam remote-loopback supported

link-oam variable-retrieve { local-info | remote-info }

Parameters:

start	Start remote loopback test on interface
stop	Stop remote loopback test on interface
interface	Start/Stop remote loopback test on a specific interface or interfaces.
*	All switches or All ports
GigabitEthernet	1 Gigabit Ethernet Port
10GigabitEthernet	10 Gigabit Ethernet Port
<port_type_list>	Port list for all port types
link-monitor	Configure link monitoring
mib-retrieval	Set MIB retrieval support
mode	Set Link OAM mode Active or Passive on this interface
remote-loopback	Link OAM remote loopback support
variable-retrieve	Set MIB variable retrieve local info or remote info
frame	Configure frame error event thresholds and window for error frames that trigger an error-frame link event
frame-seconds	Configure frame seconds summary
supported	Enable or Disable (when the no keyword is entered) link monitor on the interface
symbol-period	Configure window and thresholds for an error-symbol period that triggers an error-symbol period link event
supported	Enable or Disable (when the no keyword is entered) MIB retrieval support on the interface
active	Enable Link OAM Active mode on this interface
passive	Enable Link OAM Passive mode on this interface
local-info	Set MIB retrieve local info
remote-info	Set MIB retrieve remote info
threshold	Set a threshold in number of frames

window Set the a window of time during which error frames are counted
<0-4294967295> Threshold in number of symbols
<1-60> Set window size in terms of seconds
<cr>

Example:

```
SISPM1040-3248-L(config-if)# link-oam variable-retrieve local-info
% This feature is not supported yet.
SISPM1040-3248-L# $-oam remote-loopback start interface GigabitEthernet 1/4
% Requested configuration is not supported with the current OAM mode for Gigabit Ethernet
1/4
SISPM1040-3248-L# $am remote-loopback start interface 10GigabitEthernet 1/28 ?
% No such interface: 10GigabitEthernet 1/28
SISPM1040-3248-L# $am remote-loopback stop interface *
% Requested configuration is not supported with the current OAM mode for Gigabit Ethernet
1/1
SISPM1040-3166-L(config-if)# link-oam mode active
SISPM1040-3166-L(config-if)# link-oam
SISPM1040-3166-L(config-if)# link-oam remote-loopback supported
SISPM1040-3166-L(config-if)# link-oam link-monitor supported
SISPM1040-3166-L(config-if)#
```

Chapter 21 More Commands

Command: `more`

Description: Display file.

Syntax: `more <path>`

Parameters:

`<url_file>` File in FLASH or on a TFTP server. Syntax: `<flash:filename | tftp://server/path-and-filename>`. A valid file name is a text string drawn from alphabet (A-Za-z), digits (0-9), dot (.), hyphen (-), underscore (_). The maximum length is 63 and hyphen must not be first character. A file name that only contains '.' is not allowed.

Example:

```
SISPM1040-3248-L# more tftp://192.168.1.77/ddd | begin a
% Loading /ddd from TFTP server 192.168.1.77
% TFTP load error: Operation timed out.
SISPM1040-3248-L#
```

Chapter 22 Ping Commands

Command: ping / pingv6

Description: Send ICMP / ICMPv6 echo messages.

Syntax:

ping ip { <domain_name> | <ip_addr> } [ttl <ttl_value>] [repeat <count>] [{ saddr <src_addr> | sif { <port_type> <src_if> | vlan <vlan_id> } }] [size <size>] [data <data_value>] [{ verbose | quiet }]

ping ipv6 { <domain_name> | <ip_addr> } [repeat <count>] [saddr <src_addr>] [sif { <port_type> <src_if> | vlan <vlan_id> }] [size <size>] [data <data_value>] [{ verbose | quiet }]

Parameters:	ip	ICMPv4 Echo Request
	ipv6	ICMPv6 Echo Request
	<domain_name>	Destination hostname or FQDN
	<ipv4_addr>	Destination IPv4 address
	<domain_name>	Destination hostname or FQDN
	<ipv6_addr>	Destination IPv6 address
	data	Specify payload data byte value
	quiet	Set quiet output
	repeat	Specify repeat count
	saddr	Send from interface with source address
	sif	Send from specified interface
	size	Specify datagram size
	verbose	Set verbose output
	<cr>	

Example:

```
SISPM1040-3248-L# ping ip 192.168.1.1 repeat 3 size 3
PING 192.168.1.1 (192.168.1.1): 3 data bytes

--- 192.168.1.1 ping statistics ---
3 packets transmitted, 0 packets received, 100% packet loss
SISPM1040-3248-L#

SISPM1040-3166-L# ping ip 192.168.1.77 repeat 3 size 3
PING 192.168.1.77 (192.168.1.77): 3 data bytes
11 bytes from 192.168.1.77: seq=0 ttl=64
11 bytes from 192.168.1.77: seq=1 ttl=64
11 bytes from 192.168.1.77: seq=2 ttl=64

--- 192.168.1.77 ping statistics ---
3 packets transmitted, 3 packets received, 0% packet loss
SISPM1040-3166-L#
```

Chapter 23 PTP Commands

Command: `ptp`

Description: Set miscellaneous non-persistent 1588 settings in Exec mode. **Note** that PTP parameters can also be set in Config mode and in interface config mode.

Syntax :

```

ptp <clockinst> local-clock { update | ratio <ratio> }
ptp <clockinst> wireless delay <base_delay> [ <incr_delay> ] interface ( <port_type> [ <v_port_type_list> ] )
ptp <clockinst> wireless mode interface ( <port_type> [ <v_port_type_list> ] )
ptp <clockinst> wireless pre-notification interface ( <port_type> [ <v_port_type_list> ] )
ptp cal 1pps <cable_latency>
ptp cal p2p <port_type> <ref_port> <port_type> <other_port> <cable_latency>
ptp cal port <port_type> <v_port_type_id> [ mode { 10m-cu | 100m-cu | 1g-cu | 1g | 2g5 | 5g | 10g | all } ] reset
ptp cal port <port_type> <v_port_type_id> offset <pps_offset> cable-latency <cable_latency>
ptp cal port <port_type> <v_port_type_id> start [ synce ]
ptp cal t-plane <port_type> <v_port_type_id> { ext | int }

```

Parameters:

<0-3>	PTP Clock instance [0-3]
ext	Update the 1PPS and External clock output configuration and VCXO frequency rate adjustment option
ho-spec	Set the Holdover specification for G8275 PTP clocks
io-pin	Set or show input/output configuration
rs422	Set the RS422 clock configuration
system-time	Enable synchronization between PTP time and system time
tc-internal	0 = MODE_30BIT, 1 = MODE_32BIT, 2 = MODE_44BIT, 3 = MODE_48BIT
cal	Calibration (1pps / p2p / port / t-plane)
local-clock	Update local clock current time, or set clock ratio
wireless	Enable wireless mode for one or more interfaces.
ratio	Set the local master clock frequency ratio.
update	The local clock is synchronized to the OS system clock
<-10000000-10000000>	Ratio in units of 0,1 PPB, (ratio > 0 => faster clock, ratio < 0 => slower clock).
delay	Base wireless transmission delay (in picoseconds) <0-1000000000>
mode	Enable wireless mode for an interface.
pre-notification	Issue a pre notification that the wireless modem is going to change.
<0-1000000000>	Base wireless transmission delay (in picoseconds)
interface	Interface
*	All switches or All ports
GigabitEthernet	1 Gigabit Ethernet Port
10GigabitEthernet	10 Gigabit Ethernet Port
<port_type_list>	Port list in 1/1-28
1pps	<-100000-100000> Latency of the cable used for calibration
p2p	1 Gigabit Ethernet Port or 10 Gigabit Ethernet Port
port	1 Gigabit Ethernet Port or 10 Gigabit Ethernet Port
t-plane	external loopback / internal loopback

<-100000-100000>	Latency of the cable used for calibration
mode	100m-cu / 10g / 10m-cu / 1g / 1g-cu / 2g5 / 5g / all
reset	reset

Example:

```
SISPM1040-3248-L# ptp cal 1pps 0
Calibration of 1PPS input (cable_latency = 0)
W ptp 04:16:28 12.039,675 305/vtss_ext_clock_rs422_conf_set#7264: Warning: RS422
not supported on board type: 15
Now waiting up tp 30 seconds for calibration to be performed.
SISPM1040-3248-L# ptp cal t-plane GigabitEthernet 1/5 int
Starting calibration of t-plane on port: 5 with loopback type: Internal
Deleting any existing PTP instances
Resetting VLAN configuration to default
Adding VLAN ID 2 to allowed access VLANs
Creating PTP master and slave used for calibration
Need to wait 5 seconds before setting up internal loopback
Now waiting up tp 30 seconds for calibration to be performed.
SISPM1040-3248-L#
```

Messages:

Wireless mode not available for ptp instance 0, port 4

Wireless mode requires a two-step or Oam based BC

Calibration of 1PPS input (cable_latency = 0)

W ptp 04:16:28 12.039,675 305/vtss_ext_clock_rs422_conf_set#7264: Warning: RS422 not supported on board type: 15

Now waiting up tp 30 seconds for calibration to be performed.

Calibration aborted.

Command: **show ptp**

Description: Show Precision time Protocol (1588) data.

Syntax :

show ptp <clockinst> filter-type

show ptp <clockinst> local-clock

show ptp <clockinst> slave-cfg

show ptp <clockinst> slave-table-unicast

show ptp <clockinst> virtual-port

show ptp <clockinst> { default | current | parent | time-property | filter | servo | clk | ho | uni | master-table-unicast | slave | { { port-state | port-statistics | port-ds | wireless | foreign-master-record } [interface (<port_type> [<v_port_type_list>])] } | log-mode }

show ptp cal

show ptp ext

show ptp ms-pdv all-apr-statistics cgu <cgu_id>

show ptp ms-pdv apr cgu <cgu_id>

show ptp ms-pdv cgu <cgu_id> server <server_id> status

show ptp ms-pdv cur-path-delays cgu <cgu_id>

show ptp ms-pdv path-statistics cgu <cgu_id>
show ptp ms-pdv psl-fcl-config cgu <cgu_id>
show ptp rs422
show ptp rs422 baudrate
show ptp servo mode-ref
show ptp servo source
show ptp system-time

Parameters:

<0-3>	Show various PTP data
cal	Show the PTP calibration.
ext	Show the 1PPS and External clock output config and VCXO frequency rate adjustment option.
ms-pdv	Show the configuration of the MS-PDV.
rs422	Shows the configuration of the alternative clock that is connected to the RS422 connector.
servo	Show ptp servo mode-ref / source
system-time	Show the PTP <-> system time synchronization mode.
clk	Show PTP slave clock options parameters.
current	Show PTP current data set (IEEE1588 paragraph 8.2.2).
default	Show PTP default data set (IEEE1588 paragraph 8.2.1).
filter	Show PTP filter parameters.
filter-type	Show PTP filter type
foreign-master-record	Show PTP port foreign masters.
ho	Show PTP slave holdover parameters.
local-clock	Show local clock current time
log-mode	Show PTP log mode.
master-table-unicast	Show PTP master list of connected unicast slaves.
parent	Show PTP parent data set (IEEE1588 paragraph 8.2.3).
port-ds	Show PTP port data set (IEEE1588 paragraph 8.2.5).
port-state	Show PTP port state (Sections 8.2.5.3.1 and 9.2.5 of IEEE-1588-2008).
port-statistics	Show PTP port statistics.
servo	Show PTP servo parameters.
slave	Show PTP slave clock lock threshold parameters.
slave-cfg	Show slave lock configuration
slave-table-unicast	Show the Unicast slave table of the requested unicast masters
time-property	Show PTP time properties data set (IEEE1588 paragraph 8.2.4).
uni	Show PTP slave unicast configuration parameters.
virtual-port	Show the configuration of a PTP clocks virtual port
wireless	Show PTP port wireless parameters.
all-apr-statistics	Show ptp ms-pdv all-apr-statistics cgu <cgu_id>
apr	
cgu	
cur-path-delays	

```

path-statistics
psl-fcl-config
baudrate          Show baud rate that has been configured for the RS422 port.
mode-ref
source
cgu               <0-3>
server           <0-3>

```

Example:

```

SISPM1040-3248-L# show ptp 0 current
stpRm  OffsetFromMaster  MeanPathDelay
-----
0      0.000,000,000    0.000,000,000
SISPM1040-3248-L# show ptp 0 clk
Option threshold 'P'constant
-----
free   1000      2
SISPM1040-3248-L# show ptp 0 parent
ParentPortIdentity  port  Pstat  Var  ChangeRate
-----
00:c0:f2:ff:fe:49:39:b4 0    False  0    0

GrandmasterIdentity  GrandmasterClockQuality  Pri1  Pri2
-----
00:c0:f2:ff:fe:49:39:b4 Cl:248 Ac:Unknwn Va:65535 128 128
SISPM1040-3248-L# show ptp 0 port-state
Port  Enabled  PTP-State  Internal  Link  Port-Timer  Vlan-forw  Phy-timestamper  Peer-delay
-----
  1  FALSE  dsbl      FALSE    Down  In Sync     Discard    FALSE             OK
  2  FALSE  dsbl      FALSE    Up    In Sync     Discard    FALSE             OK
  3  FALSE  dsbl      FALSE    Down  In Sync     Discard    FALSE             OK
  4  FALSE  dsbl      FALSE    Down  In Sync     Discard    FALSE             OK
  5  TRUE   dsbl      FALSE    Down  In Sync     Discard    FALSE             OK
  6  FALSE  dsbl      FALSE    Down  In Sync     Discard    FALSE             OK
  7  FALSE  dsbl      FALSE    Down  In Sync     Discard    FALSE             OK
  8  FALSE  dsbl      FALSE    Down  In Sync     Discard    FALSE             OK
  9  FALSE  dsbl      FALSE    Down  In Sync     Discard    FALSE             OK
-- more --, next page: Space, continue: g, quit: ^C
SISPM1040-3248-L# show ptp ext
PTP External One PPS mode: Disable, Clock output enabled: False, frequency : 1,
Preferred adj method: Auto
SISPM1040-3248-L# show ptp ms-pdv cgu 0 server 1 status
L1 = False
L2 = True
L3 = False
L = False
gstL = False
V = False
gstV = False

```

```
S = False
U = False
U1 = True
PE = True
PA = False
gstPA = False
H = False
gstH = False
OOR = False
ttErrDetected = False
outageDetected = False
outlierDetected = False
frrDetected = False
rrrDetected = False
stepDetected = False
SISPM1040-3248-L#
```

Messages:

W ptp/ms_servo 21:56:20 150/vtss_appl_ptp_ext_clock_out_set#6940: Warning: Error code: Cannot change preferred adj method if active PTP instances are using clock domain 0

W web 21:56:20 150/handler_config_ptp#532: Warning: The preferred adjust method is not supported

W zl_30380 22:12:32 75.734,416 305/zl_30380_apr_show_statistics#1791: Warning: ZL Error code: 7d2 System clock synch mode (No System clock to PTP Sync)

PTP Port States (PTP-State column)

initializing(1),

faulty(2),

disabled(3),

listening(4),

preMaster(5),

master(6),

passive(7),

uncalibrated(8),

slave(9)

Chapter 24 Reload Commands

Command: reload

Description: Reload system.

Syntax: **reload** { { { warm } [sid <usid>] } | { defaults [keep-ip] } }

Parameters: defaults Reload defaults without rebooting.
warm Reload warm (CPU restart only).
keep-ip Attempt to keep VLAN1 IP setup.
<cr>

Example:

```
SISPM1040-3166-L# reload ?
  defaults    Reload defaults without rebooting.
  warm        Reload warm (CPU restart only).
SISPM1040-3166-L# reload warm
% Warm reload in progress, please stand by.
SISPM1040-3166-L# reload defaults keep-ip
% Reloading defaults, attempting to keep IP address. Please stand by.
<Enter>

Username:
Password:
```

Chapter 25 Send Commands

Command: send

Description: Send a message to other tty lines.

Syntax: send { * | <session_list> | console 0 | vty <vty_list> } <message>

Parameters:

*	All tty lines
<0~16>	Send a message to multiple lines
console	Primary terminal line
vty	Virtual terminal

Example:

```
SISPM1040-3248-L# send * aaa
```

```
-----  
*** Message from line 1:  
-----
```

```
SISPM1040-3248-L#
```

Chapter 26 Show Commands

Command: **show**

Description: Display the parameters of a function.

Syntax: Use the **show??** command to display the list of all commands and their parameters (it's a long list).

Parameters: Use the **show <tab>** command to display the available show parameters:

HW	aaa	access	access-list	aggregation
always-on-poe	clock	dot1x	eps	erps
evc	event	green-ethernet	history	interface
ip	ipmc	ipv6	lacp	licenses
line	link-oam	lldp	logging	loop-protect
mac	map-api-key	mep	monitor	mrp
mrp-ring	mvr	ntp	perf-mon	platform
poe	port-security	privilege	process	ptp
pvlan	qos	radius-server	rapid-ring	rfc2544
rmon	running-config	sflow	smtp	snmp
spanning-tree	svl	switchport	system	tacacs-server
terminal	traffic-test-loop	udld	upnp	user-privilege
users	version	vlan	voice	watchdog
web	y1564			

Each of these is described below in examples.

Example: show HW:

```
SISPM1040-3248-L# show HW monitor
Powers Status           : Normal
Power 3.3V              : 3.28V
Power 2.5V              : 2.57V
Power 1.5V              : 1.52V
Power 1.0V              : 1.01V
Power 12.0V             : 12.00V
Temperature Status      : Normal
Temperature 1           : 45(C) ; 113(F)
Temperature 2           : 44(C) ; 111(F)
SISPM1040-3248-L#
```

Example: **show aaa:**

```
SISPM1040-3248-L# show aaa
Authentication :
  console : local
  telnet  : local
  ssh     : local
  http    : local
  https   : no
Authorization :
  console : no, commands disabled
  telnet  : no, commands disabled
  ssh     : no, commands disabled
Accounting :
  console : no, commands disabled, exec disabled
  telnet  : no, commands disabled, exec disabled
  ssh     : no, commands disabled, exec disabled
SISPM1040-3248-L#
```

Example: **show access management:**

```
SISPM1040-3248-L# show access management ?
  <1~16>      ID of access management entry
  |           Output modifiers
  statistics  Statistics data
  <cr>

SISPM1040-3248-L# show access management
Switch access management mode is disabled

W: WEB/HTTPS
S: SNMP
T: TELNET/SSH

Idx VID  Start IP Address                End IP Address                W S T
-----
SISPM1040-3248-L#
```

Example: show access-list:

```

SISPM1040-3248-L# show access-list ?
|          Output modifiers
ace        Access list entry
ace-status The local ACEs status
interface  Select an interface to configure
rate-limiter Rate limiter
<cr>
SISPM1040-3248-L# show access-list
Switch access-list ace number: 0
Switch access-list rate limiter ID 1 is 10 pps
Switch access-list rate limiter ID 2 is 10 pps
Switch access-list rate limiter ID 3 is 10 pps
Switch access-list rate limiter ID 4 is 10 pps
Switch access-list rate limiter ID 5 is 10 pps
Switch access-list rate limiter ID 6 is 10 pps
Switch access-list rate limiter ID 7 is 10 pps
Switch access-list rate limiter ID 8 is 10 pps
Switch access-list rate limiter ID 9 is 10 pps
Switch access-list rate limiter ID 10 is 10 pps
Switch access-list rate limiter ID 11 is 10 pps
Switch access-list rate limiter ID 12 is 10 pps
Switch access-list rate limiter ID 13 is 10 pps
Switch access-list rate limiter ID 14 is 10 pps
Switch access-list rate limiter ID 15 is 10 pps
Switch access-list rate limiter ID 16 is 10 pps

GigabitEthernet 1/1 :
-----
-- more --, next page: Space, continue: g, quit: ^C

```

Example: show aggregation:

```

SISPM1040-3248-L# show aggregation ?
|          Output modifiers
mode      Traffic distribution mode
<cr>
SISPM1040-3248-L# show aggregation
SISPM1040-3248-L# show aggregation mode ?
|          Output modifiers
<cr>
SISPM1040-3248-L# show aggregation mode
Aggregation Mode:

SMAC   : Enabled
DMAC   : Disabled
IP     : Enabled
Port   : Enabled
SISPM1040-3248-L#

```

Example: **show always-on-poe:**

```
SISPM1040-3248-L# show always-on-poe ?
|      Output modifiers
<cr>
SISPM1040-3248-L# show always-on-poe
Always On PoE Status : Enable
SISPM1040-3248-L#
```

Example: **show clock**

```
SISPM1040-3248-L# show clock ?
detail    Display detailed information
<cr>
SISPM1040-3248-L# show clock
System Time      : 2016-01-01T02:03:01+00:00

SISPM1040-3248-L# show clock detail
System Time      : 2016-01-01T02:03:07+00:00

Timezone : Timezone Offset : 0 ( 0 minutes)
Timezone Acronym :

Daylight Saving Time Mode : Disabled.
Daylight Saving Time Start Time Settings :
    Week: 1
    Day: 1
    Month: 1
    Date: 1
    Year: 2014
    Hour: 0
    Minute: 0
Daylight Saving Time End Time Settings :
    Week: 1
    Day: 1
    Month: 1
    Date: 1
    Year: 2097
    Hour: 0
    Minute: 0
-- more --, next page: Space, continue: g, quit: ^C
```

Example: **show dot1x status / statistics**SISPM1040-3248-L# **show dot1x ?**

statistics Shows statistics for either EAPoL or RADIUS.

status Shows dot1x status, such as admin state, port state and last source.

SISPM1040-3248-L# **show dot1x status**

Interface	Admin	Port	State	Last Src	Last ID	QOS	VLAN	Guest
Gi 1/1	Auth	Disabled	-	-	-	-	-	-
Gi 1/2	Auth	Disabled	-	-	-	-	-	-
Gi 1/3	Auth	Disabled	-	-	-	-	-	-
Gi 1/4	Auth	Disabled	-	-	-	-	-	-
Gi 1/5	Auth	Disabled	-	-	-	-	-	-
Gi 1/6	Auth	Disabled	-	-	-	-	-	-
Gi 1/7	Auth	Disabled	-	-	-	-	-	-
Gi 1/8	Auth	Disabled	-	-	-	-	-	-
Gi 1/9	Auth	Disabled	-	-	-	-	-	-
Gi 1/10	Auth	Disabled	-	-	-	-	-	-
Gi 1/11	Auth	Disabled	-	-	-	-	-	-
Gi 1/12	Auth	Disabled	-	-	-	-	-	-
Gi 1/13	Auth	Disabled	-	-	-	-	-	-
Gi 1/14	Auth	Disabled	-	-	-	-	-	-
Gi 1/15	Auth	Disabled	-	-	-	-	-	-
Gi 1/16	Auth	Disabled	-	-	-	-	-	-
Gi 1/17	Auth	Disabled	-	-	-	-	-	-
Gi 1/18	Auth	Disabled	-	-	-	-	-	-

SISPM1040-3248-L# **show dot1x statistics ?**

all Show all dot1x statistics

eapol Show EAPoL statistics

radius Show Back-end Server statistics

SISPM1040-3248-L# **show dot1x statistics radius**

Interface	Rx Access Challenges	Rx Other Requests	Rx Auth. Successes	Rx Auth. Failures	Tx Responses	MAC Address
Gi 1/1	0	0	0	0	0	-
Gi 1/2	0	0	0	0	0	-
Gi 1/3	0	0	0	0	0	-
Gi 1/4	0	0	0	0	0	-
Gi 1/5	0	0	0	0	0	-
Gi 1/6	0	0	0	0	0	-
Gi 1/7	0	0	0	0	0	-
Gi 1/8	0	0	0	0	0	-
Gi 1/9	0	0	0	0	0	-
Gi 1/10	0	0	0	0	0	-
Gi 1/11	0	0	0	0	0	-
Gi 1/12	0	0	0	0	0	-
Gi 1/13	0	0	0	0	0	-
Gi 1/14	0	0	0	0	0	-
Gi 1/15	0	0	0	0	0	-
Gi 1/16	0	0	0	0	0	-

```

Gi 1/17          0          0          0          0          0 -
Gi 1/18          0          0          0          0          0 -
-- more --, next page: Space, continue: g, quit: ^C

```

Example: **show eps** (Ethernet Protection Switching)

```
SISPM1040-3248-L# show eps
```

```
EPS state is:
```

Inst	State	Wstate	Pstate	TxAps r b	RxAps r b	Fop
Pm	FopCm	FopNr	FopNoAps			

```
SISPM1040-3248-L# show eps ?
```

```

|           Output modifiers
<range_list> The range of EPS instances.
detail       Show detailed state including configuration information.
<cr>

```

```
SISPM1040-3248-L# show eps detail
```

```
EPS state is:
```

Inst	State	Wstate	Pstate	TxAps r b	RxAps r b	Fop
Pm	FopCm	FopNr	FopNoAps			

```
EPS Configuration is:
```

Inst	Dom	Archi	Wflow	Pflow	Wmep	Pmep	APSmep
Direct	Revert	Wtr	Hold	Aps			

```
EPS Command is:
```

Inst	Command

```
SISPM1040-3248-L#
```

Example: **show evc** (Ethernet Virtual Connections)

```

SISPM1040-3248-L# show evc ?
|          Output modifiers
<1-454>    EVC identifier
all        Process all EVCs
ece        EVC Control Entry
statistics  Statistic counters
<cr>
SISPM1040-3248-L# show evc 1
EVC ID  Status
-----  -----
1       Active

SISPM1040-3248-L# show evc ece
SISPM1040-3248-L# show evc statistics
SISPM1040-3248-L# show evc 1 ?
|          Output modifiers
ece        EVC Control Entry
<cr>
SISPM1040-3248-L# show evc 1 ece
EVC ID  Status
-----  -----
1       Active

SISPM1040-3248-L#

```

Example: **show event** (Show trap event configuration)

```

SISPM1040-3248-L# show event
Group Name                Severity Level  Syslog Mode  Trap Mode  SMTP Mode  Digital Out
-----
AC-Power                  Information     enable       disable    disable    N/A
ACL                       Information     enable       disable    disable    N/A
ACL-Log                   Information     enable       disable    disable    N/A
Access-Mgmt               Information     enable       disable    disable    N/A
Auth-Failed               Warning         enable       disable    disable    N/A
Battery-Power             Information     enable       disable    disable    N/A
Cold-Start                Warning         enable       disable    disable    N/A
Config-Info               Information     enable       disable    disable    N/A
-- more --, next page: Space, continue: g, quit: ^C

```

Example: **show green-ethernet** (Power reduction)

```
SISPM1040-3248-L# show green-ethernet
Interface          Lnk Energy-detect Short-Reach  EEE Capable  EEE Enable
d LP EEE Capable  EEE In Power Save
-----
-
GigabitEthernet 1/1   Yes No           No           Yes          No
  No                No
GigabitEthernet 1/2   No  No           No           Yes          Yes
  No                No
GigabitEthernet 1/3   No  No           No           Yes          Yes
  No                No
GigabitEthernet 1/4   No  No           No           Yes          Yes
  No                No
GigabitEthernet 1/5   No  No           No           Yes          Yes
  No                No
GigabitEthernet 1/6   No  No           No           Yes          No
  No                No
GigabitEthernet 1/7   No  No           No           Yes          No
  No                No
GigabitEthernet 1/8   No  No           No           Yes          No
  No                No
GigabitEthernet 1/9   No  No           No           Yes          No
  No                No
-- more --, next page: Space, continue: g, quit: ^C
```

Example: **show history** (Display the session command history)

```
SISPM1040-3248-L# show history
show
show aaa
show access management
show access-list
show aggregation
show aggregation mode
show board-data
show clock
show clock detail
show dot1x statistics
show dot1x statistics radius
show eps detail
show erps detail
show erps statistics
show evc
con ter
evc 1 ivid 10 learning nni egress-map 0 ingress-map 1
end
-- more --, next page: Space, continue: g, quit: ^C
```

Example: **show hw monitor** (power and temperature) parameters:

```
SISPM1040-3248-L# show hw monitor
Powers Status          : Normal
Power 3.3V             : 3.24V
Power 2.5V             : 2.60V
Power 1.8V             : 1.52V
Power 1.0V             : 1.01V
Power 12.0V            : 11.93V
Temperature Status     : Normal
Temperature 1          : 40(C) ; 104(F)
Temperature 2          : 42(C) ; 107(F)
SISPM1040-3248-L#
```

Example: **show Interface** parameters.

```
SISPM1040-3248-L# show interface ?
*                All switches or All ports
GigabitEthernet  1 Gigabit Ethernet Port
10GigabitEthernet 10 Gigabit Ethernet Port
vlan             VLAN status
SISPM1040-3248-L# show interface * ?
<port_type_list> Port list for all port types
CableDiag        Display the latest cable diagnostic results.
capabilities      Display capabilities.
description       Show port description.
statistics        Display statistics counters.
status           Display status.
switchport       Show interface switchport information
SISPM1040-3248-L# show interface * status
Interface        Mode      Speed & Duplex  Flow Control  Max Frame  Excessive  Link
-----
GigabitEthernet 1/1    enabled  Auto           disabled      10240      Discard    1Gfdx
GigabitEthernet 1/2    enabled  Auto           disabled      10240      Discard    Down
GigabitEthernet 1/3    enabled  Auto           disabled      10240      Discard    Down
GigabitEthernet 1/4    enabled  Auto           disabled      10240      Discard    Down
GigabitEthernet 1/5    enabled  Auto           disabled      10240      Discard    Down
GigabitEthernet 1/6    enabled  Auto           disabled      10240      Discard    Down
GigabitEthernet 1/7    enabled  Auto           disabled      10240      Discard    Down
GigabitEthernet 1/8    enabled  Auto           disabled      10240      Discard    Down
GigabitEthernet 1/9    enabled  Auto           disabled      10240      Discard    Down
SISPM1040-3248-L# show interface * capabilities
GigabitEthernet 1/25 Capabilities:
Connector Type    : none
Fiber Type        : none
TX Central Wavelength: none
Bit Rate          : none
Vendor OUI        : none
Vendor name       : none
```

```

Vendor PN           : none
Vendor revision     : none
Vendor Serial Number : none
Data Code           : none
Temperature         : none
Vcc:                : none
Mon1(Bias)         : none
Mon2(TX PWR)       : none
Mon3(RX PWR)       : none

```

-- more --, next page: Space, continue: g, quit: ^C

Example: **show ip** (Interface Internet Protocol) parameters

```

SISPM1040-3248-L# show ip ?
  acd           Address Conflict Detection
  arp           Address Resolution Protocol
  dhcp         Dynamic Host Configuration Protocol
  domain       Default domain name
  http         Hypertext Transfer Protocol
  igmp         Internet Group Management Protocol
  interface    IP interface status and configuration
  link-local   show Link-Local address binding interface
  name-server  Domain Name System
  route        Display the current IP routing table
  source       source command
  ssh          Secure Shell
  statistics   Traffic statistics
  telnet       Telnet
  verify       verify command
SISPM1040-3248-L# show ip acd
SISPM1040-3248-L# show ip source binding
SISPM1040-3248-L# show ip ssh
Switch SSH is enabled
Switch scp is disabled
SISPM1040-3248-L# show ip ssh key
W ssh 00:44:05 140/process-daemon.cxx#235: Warning: ssh_showkey-258 STDOUT>
Public key portion is:
  521 ecdsa-sha2-nistp521 AAAAE2VjZHNhLXNoYTItbmlzdHA1MjEAAAABmlzdHA1MjEAAACFBAC
  1XWGHZq2WHRbKj6RILAhwbxBfHRIkCCzHBwSmg1D1Do9rGjJgyXY03LswxsSbnJUMPBnxbdggy4Y5ts5
  om5bnqwHfNjb+pJWH8+RYJ6qNDcvfvosPfeBMBIbHsAPFV/2LImtNByu296ziFxQBEFb1EsG99na5jB+
  6BQaqpJuukiWp5Q==
Fingerprint: md5 5d:a1:37:0e:a0:0d:36:0c:4c:49:41:3e:6f:67:23:be
SISPM1040-3248-L# show ip link-local interface
Link-Local Address binding interface: 1
SISPM1040-3248-L#

```

Example: **show ipmc** (IPv4/IPv6 multicast) parameters

```
SISPM1040-3248-L# show ipmc ?
  profile    IPMC profile configuration
  range      A range of IPv4/IPv6 multicast addresses for the profile
SISPM1040-3248-L# show ipmc profile ?
  <word16>   Profile name in 16 characters
  detail     Detail information of a profile
SISPM1040-3248-L# show ipmc profile

IPMC Profile is currently disabled, please enable profile to start filtering.
SISPM1040-3248-L# show ipmc range
SISPM1040-3248-L#
```

Example: **show ipv6** parameters

```
SISPM1040-3248-L# show ipv6 ?
  dhcp-client  Manage DHCPv6 client service
  interface    Select an interface to configure
  mld          Multicast Listener Discovery
  neighbor     IPv6 neighbors
  route        IPv6 routes
  statistics   Traffic statistics
SISPM1040-3248-L# show ipv6 mld snooping ?
  |           Output modifiers
  detail      Detail running information/statistics of MLD snooping
  group-database  Multicast group database from MLD
  mrouter     Multicast router port status in MLD
  vlan        Search by VLAN
  <cr>
SISPM1040-3248-L# show ipv6 mld snooping vlan 10
```

MLD Snooping is enabled to start snooping MLD control plane.

```
SISPM1040-3248-L# show ipv6 route
SISPM1040-3248-L# show ipv6 statistics
IPv6 system statistics:
Rx Packets:                0   Tx Packets:   46
Rx Octets:                  0   Tx Octets:  2900
Rx Unicast:                 0   Tx Unicast:   0
Rx Multicast:               0   Tx Multicast:  46
Rx Broadcast:               0   Tx Broadcast:  0
Rx Discards:                0   Tx Discards:  0
Rx ReasmOKs:                0   Tx FragOKs:   0
Rx ReasmReqds:              0   Tx FragCreates: 0
Rx ReasmFails:              0   Tx FragFails: 0
Rx Delivers:                0
Rx HdrErrors:               0
Rx AddrErrors:              0
-- more --, next page: Space, continue: g, quit: ^C
```

Example: **show lacp** (LACP configuration/status)

```
SISPM1040-3248-L# show lacp ?
  internal      Internal LACP configuration
  neighbor      Neighbor LACP status
  statistics     Internal LACP statistics
  system-id     LACP system id
SISPM1040-3248-L# show lacp system-id ?
  |             Output modifiers
  details       LACP state
  <cr>
SISPM1040-3248-L# show lacp system-id
System ID: 32768 - 00:c0:f2:49:39:b4
SISPM1040-3248-L# show lacp internal ?
  |             Output modifiers
  details       LACP state
  <cr>
SISPM1040-3248-L# show lacp internal
SISPM1040-3248-L#
```

Example: **show licenses** (Display license information)

```
SISPM1040-3248-L# show licenses ?
  |             Output modifiers
  component     component key word - Select a specific component to show
  description    description keyword - Shows the licenses description, else
                only an overview is shown.
  mtd           MTD keyword - Select a specific MTD (file) to show
  section       section key word - Select a specific section to show
  <cr>
SISPM1040-3248-L# show licenses
Image Name  SectionID  ComponentID  Component Name          Version          Type          Url
-----
-----
RedBoot    No licenses found
linux      0          0            libstdc++               6.3.0
           GPLv3 (with exception)  http://ftpmirror.gnu.org/gcc/gcc-6.3.0/gcc-6.3.0.tar.bz2
linux      0          1            uclibc                  1.0.22          LGPLv2.1+
           http://downloads.uclibc-ng.org/releases/1.0.22/uClibc-ng-1.0.22.tar.xz
linux      0          2            linux-headers           4.9.13
           GPLv2          https://cdn.kernel.org/pub/linux/kernel/v4.x/linux-4.9.13.tar.xz
linux      0          3            mscclinux               835a2802137cfe955a2fa48a9e67cb111058021a GPLv2
linux      0          4            mbedtls                 2.4.0           Apache-2.0
           https://tls.mbed.org/code/releases/mbedtls-2.4.0-apache.tgz
-- more --, next page: Space, continue: g, quit: ^C
```

Example: **show line** (TTY line) information

```
SISPM1040-3248-L# show line
```

```
Line is con 0.
```

```
-----
```

```
Not alive.
```

```
Default privileged level is 2.
```

```
Command line editing is enabled
```

```
Display EXEC banner is enabled.
```

```
Display Day banner is enabled.
```

```
Terminal width is 80.
```

```
    length is 24.
```

```
    history size is 32.
```

```
    exec-timeout is 10 min 0 second.
```

```
Current session privilege is 0.
```

```
Elapsed time is 0 day 0 hour 0 min 0 sec.
```

```
Idle time is 0 day 0 hour 0 min 0 sec.
```

```
Line is vty 0.
```

```
-----
```

```
* You are at this line now.
```

```
Alive from Telnet.
```

```
Default privileged level is 2.
```

```
Command line editing is enabled
```

```
SISPM1040-3248-L# show line alive
```

```
Line is vty 0.
```

```
-----
```

```
* You are at this line now.
```

```
Alive from Telnet.
```

```
Default privileged level is 2.
```

```
Command line editing is enabled
```

```
Display EXEC banner is enabled.
```

```
Display Day banner is enabled.
```

```
Terminal width is 80.
```

```
    length is 24.
```

```
    history size is 32.
```

```
    exec-timeout is 10 min 0 second.
```

```
Current session privilege is 15.
```

```
Elapsed time is 0 day 0 hour 0 min 59 sec.
```

```
Idle time is 0 day 0 hour 0 min 0 sec.
```

```
SISPM1040-3248-L#
```

Example: **show link-oam** configuration

```
SISPM1040-3248-L# show link-oam?
  link-oam      Link OAM configuration
  <cr>
SISPM1040-3248-L# show link-oam?
show link-oam { [ status ] [ link-monitor ] [ statistics ] } [ interface ( <port_type> [
<plist> ] ) ]
SISPM1040-3248-L# show link-oam
```

Interface		Control	Mode	Status
GigabitEthernet	1/1	disabled	passive	non operational
GigabitEthernet	1/2	disabled	passive	non operational
GigabitEthernet	1/3	disabled	passive	non operational
GigabitEthernet	1/4	disabled	passive	non operational
GigabitEthernet	1/5	disabled	passive	non operational
GigabitEthernet	1/6	disabled	passive	non operational
GigabitEthernet	1/7	disabled	passive	non operational

-- more --, next page: Space, continue: g, quit: ^C

Example: **show lldp** (Link Layer Discover Protocol) parameters

```
SISPM1040-3248-L# show lldp statistics
```

```
LLDP global counters
```

```
Neighbor entries was last changed at 2015-12-31T23:59:36+00:00 (68958 secs. ago).
```

```
Total Neighbors Entries Added 0.
```

```
Total Neighbors Entries Deleted 0.
```

```
Total Neighbors Entries Dropped 0.
```

```
Total Neighbors Entries Aged Out 0.
```

```
LLDP local counters
```

Interface	Rx TLV	Rx TLV	Tx	Rx	Rx	Rx TLV
	Unknown	Organiz.	Frames	Errors	Discards	Errors
		Aged				
GigabitEthernet 1/1	0	0	2141	0	0	0
GigabitEthernet 1/2	0	0	155	0	0	0
GigabitEthernet 1/3	0	0	0	0	0	0

```
-- more --, next page: Space, continue: g, quit: ^C
```

```
SISPM1040-3248-L# show lldp neighbors
```

```
Local Interface : GigabitEthernet 1/1
```

```
Chassis ID : 5C-FF-35-DC-0A-C1
```

```
Port ID : 5C-FF-35-DC-0A-C1
```

```
Port Description :
```

```
System Name :
```

```
System Description :
```

```
System Capabilities :
```

```
PoE Type :
```

```
PoE Source :
```

```
PoE Power :
```

```
PoE Priority :
```

```
Local Interface : GigabitEthernet 1/6
```

```
Chassis ID : AC-CC-8E-BA-F7-C1
```

```
Port ID : AC-CC-8E-BA-F7-C1
```

```
Port Description : eth0
```

```
System Name : axis-accc8ebaf7c1
```

```
System Description : AXIS P1447-LE Network Camera 7.35.2.3
```

```
System Capabilities : Bridge(-), WLAN Access Point(-), Router(-), Station Only(+)
```

```
Management Address : 192.168.0.90 (IPv4)
```

```
PoE Type :
```

```
SISPM1040-3248-L#
```

Example: **show logging** (System logging) messages

```
SISPM1040-3248-L# show logging
Switch logging host mode is disabled
Switch logging host address is null
Switch logging host port is 514
Number of entries on Switch 1:
Emergency   : 0
Alert       : 0
Critical    : 0
Error       : 0
Warning     : 7
Notice      : 8
Information : 37
Debug       : 0
All         : 52

ID   Level   Time                               Message
-----
  1  Notice  2016-01-01T00:01:01+00:00  LINK-UPDOWN: Interface Vlan 1, changed state to down
  2  Notice  2016-01-01T00:01:01+00:00  LINK-UPDOWN: Interface Vlan 1, changed state to down
-- more --, next page: Space, continue: g, quit: ^C
```

Example: **show loop-protect** (Loop protection) parameters

```
SISPM1040-3248-L# show loop-protect

Loop Protection Configuration
=====
Loop Protection   : Disable
Transmission Time : 5 sec
Shutdown Time    : 180 sec

GigabitEthernet 1/1
-----
  Loop protect mode is enabled.
  Action is shutdown.
  Transmit mode is enabled.
  No loop.
  The number of loops is 0.
  Status is up.

GigabitEthernet 1/2
-----
  Loop protect mode is enabled.
  Action is shutdown.
  Transmit mode is enabled.
  No loop.
-- more --, next page: Space, continue: g, quit: ^C
```

Example: **show mac** (MAC Address Table) information

```
SISPM1040-3248-L# show mac address-table
Type   VID  MAC Address          Ports
Dynamic 1   00:1b:11:b2:6d:4b GigabitEthernet 1/1
Static  1   33:33:00:00:00:01 GigabitEthernet 1/1-28 10GigabitEthernet 1/1-4 CPU
Static  1   33:33:ff:49:39:b4 GigabitEthernet 1/1-28 10GigabitEthernet 1/1-4 CPU
Static  1   ff:ff:ff:ff:ff:ff GigabitEthernet 1/1-28 10GigabitEthernet 1/1-4 CPU
SISPM1040-3248-L#
SISPM1040-3166-L# show mac address-table ?
|
|      Output modifiers
address  MAC address lookup
aging-time  Aging time
conf      User added static mac addresses
count     Total number of mac addresses
interface Select an interface to configure
learning  Learn/disable/secure state
static    All static mac addresses
vlan      Addresses in this VLAN
<cr>
SISPM1040-3166-L#
```

Example: show **map-api-key** (show Google Map API key configuration)

```
SISPM1040-3166-L# show map-api-key
Key   :
SISPM1040-3166-L# show map-api-key
Key   : Nmb6f%25%5E.%3F%2F
SISPM1040-3166-L#
```

Example: **show mep** (Maintenance Entity Point)

```
SISPM1040-3248-L# show mep

Oper = 'Up' ->   The instance is UP meaning it is physically configured and operational
Oper = 'Down' -> The instance is DOWN meaning it is NOT physically configured and
operational
Oper = 'Config' -> The instance is DOWN due to invalid configuration
Oper = 'HW' ->   The instance is DOWN due to failing OAM supporting HW resources
Oper = 'MCE' ->  The instance is DOWN due to failing MCE resources

MEP state is:
  Inst  Oper  cLevel  cMeg  cMep  cAis  cLck  cLoop  cConf  cDeg  cSsf  aBlk  aT
sd  aTsf  Peer  MEP  cLoc  cRdi  cPeriod  cPrio

SISPM1040-3248-L#
SISPM1040-3166-L# show mep ?
|
|      Output modifiers
<range_list>  The range of MEP instances
ais            Show AIS state
```

```

aps          Show APS state
cc           Show CC state
client       Show Client state
detail       Show detailed state including configuration information.
dm           Show DM state
lb           Show LB state
lck          Show LCK state
lm           Show LM state
lm-avail     show Availability state
lm-hli       show LM HLI state
lst          show LST state
lt           Show LT state
peer         Show peer MEP state
pm           Show PM state
syslog       Show Syslog state
tlv          show TLV state
tst          Show TST state
<cr>

```

SISPM1040-3166-L#

Example: **show monitor** (Monitoring different system events)

SISPM1040-3248-L# **show monitor session all**

Session 1

```

Mode           : Disabled
Type           : Mirror
Source VLAN(s) :
CPU Port       :

```

Session 2

```

Mode           : Disabled
Type           : Mirror
Source VLAN(s) :
CPU Port       :

```

Session 3

```

Mode           : Disabled
Type           : Mirror
Source VLAN(s) :
CPU Port       :

```

-- more --, next page: Space, continue: g, quit: ^C

Example: **show mrp** (MRP status)

```

SISPM1040-3248-L# show mrp status ?
  all          Show MRP statistics for all MRP Applications.
  interface    Interface specification.
  mvrp         Show MRP statistics for the MVRP Application.
  <cr>
SISPM1040-3248-L# show mrp status
GigabitEthernet 1/1 :
-----
MRP Appl  FailedRegistrations  LastPduOrigin
-----
MVRP      0                    00-00-00-00-00-00

GigabitEthernet 1/2 :
-----
MRP Appl  FailedRegistrations  LastPduOrigin
-----
MVRP      0                    00-00-00-00-00-00

GigabitEthernet 1/3 :
-----
MRP Appl  FailedRegistrations  LastPduOrigin
-----
MVRP      0                    00-00-00-00-00-00

GigabitEthernet 1/4 :
-----
MRP Appl  FailedRegistrations  LastPduOrigin
-----
-- more --, next page: Space, continue: g, quit: ^C

```

Example: **show mrp-ring**

```

SISPM1040-3248-L# show mrp-ring 1
Operational:
  Role:                Manager
  Status:              Enabled
  Ring State:          Undefined
  Primary Ring Port State: Not connected
  Secondary Ring Port State: Not connected
Domain:
  Admin Role:          Manager
  Name:                Domain1
  UUID:                Default
  Primary Ring Port ID: 4
  Secondary Ring Port ID: 8
  VLAN ID:             100
Manager:
  Priority:              0
  Topology Change Interval, ms: 12

```

```

Topology Change Repeat Count:    2
Short Test Interval, ms:        10
Default Test Interval, ms:      20
Test Monitoring Count:          3
Test Monitoring Extended Count: 15
Non-blocking MRC supported:     Disabled
React On Link Change:           Disabled
Check Media Redundancy Event:   Enabled
SISPM1040-3248-L# show mrp-ring 1 diag
Status                          : 0x00()
Error                           : 0x01(No error)
Transitions                      :      0
Transitions                      :      0
MRP Received Frames              :      0
MRP Received Errors              :      0
MRP Received Unrecognized        :      0
Tx Error Total                   :      0
Rx Vlan Frames Total             :      0
Rx Test Frames Total             :      0
Rx Topology Change Frames Total  :      0
Rx Link Change Frames Total     :      0
ACL counter 0                    :      0
ACL counter 1                    :      0
Round Trip Delay Minimum, ms     :      0
Round Trip Delay Average, ms     :      0
Round Trip Delay Maximum, ms    :      0
Ring Open Count                  :      0
Lost frames by sequence id       :      0
Mixed frames by sequence id     :      0
Received with different UUID     :      0
Loop detected                     :      0
SISPM1040-3248-L# show mrp-ring 1 ringport
Primary Ring Port ID:           4
Status:                          Not connected
Secondary Ring Port ID:         8
Status:                          Not connected
SISPM1040-3248-L#

```

Example: **show mvr** (Multicast VLAN Registration) configuration

```

SISPM1040-3248-L# show mvr

MVR is currently disabled, please enable MVR to start group registration.
SISPM1040-3248-L# show mvr

MVR is now enabled to start group registration.

Switch-1 MVR-IGMP Interface Status

IGMP MVR VLAN 10 (Name is MVRCFG1) interface is enabled.

```

```

Querier status is IDLE
RX IGMP Query:0 V1Join:0 V2Join:0 V3Join:0 V2Leave:0
TX IGMP Query:0 / (Source) Specific Query:0
Interface Channel Profile: <No Associated Profile>

```

Switch-1 MVR-MLD Interface Status

```

MLD MVR VLAN 10 (Name is MVRCFG1) interface is enabled.
Querier status is IDLE
RX MLD Query:0 V1Report:0 V2Report:0 V1Done:0
TX MLD Query:0 / (Source) Specific Query:0
Interface Channel Profile: <No Associated Profile>
SISPM1040-3248-L#

```

Example: **show ntp status** (Network Timing Protocol)

```

SISPM1040-3248-L# show ntp status
NTP Mode : disabled
Idx  Server IP host address (a.b.c.d) or a host name string
---  -----
1
2
3
4
5
SISPM1040-3248-L#

```

Example: **show perf-mon** (Performance Monitor)

```

SISPM1040-3166-L# show perf-mon ?
    current          Current interval ID
    interval-id      Specific interval
    interval-info    Measurement interval information
SISPM1040-3166-L# show perf-mon??
show perf-mon interval-info [ id <b_id_number> ] [ feature { lm | dm | evc } ]
show perf-mon { current | interval-id <interval_id> [ instance <instance_id> ] }
    feature { lm | dm | evc }
SISPM1040-3166-L# show perf-mon interval-id 1 feature dm
SISPM1040-3166-L# show perf-mon interval-id 1 feature lm
SISPM1040-3166-L# show perf-mon interval-id 1 feature evc
SISPM1040-3248-L# show perf-mon current feature evc

Interval ID : 1998
-----
    EVC instance      = 1
    EVC port          = GigabitEthernet 1/2
    Valid             = yes
    Cos                = UNI-0

    Tx green frames   = 0

```

```

Tx green bytes      = 0
Tx yellow frames   = 0
Tx yellow bytes    = 0
Tx discard frames  = 0
Tx discard bytes   = 0

Rx green frames    = 0
Rx green bytes     = 0
Rx yellow frames   = 0
Rx yellow bytes    = 0
Rx red frames      = 0
Rx red bytes       = 0
Rx discard frames  = 0

-- more --, next page: Space, continue: g, quit: ^C
SISPM1040-3248-L# show perf-mon interval-info
EVC Interval Information
-----
Measurement interval ID = 1903
Start time               = 2019-01-08T02:08:49+00:00
End time                 = 2019-01-08T02:09:49+00:00
Elapsed time             = 60 seconds

Measurement interval ID = 1904
Start time               = 2019-01-08T02:09:49+00:00
End time                 = 2019-01-08T02:10:49+00:00
Elapsed time             = 60 seconds

Measurement interval ID = 1905
Start time               = 2019-01-08T02:10:49+00:00
End time                 = 2019-01-08T02:11:49+00:00
Elapsed time             = 60 seconds

Measurement interval ID = 1906
Start time               = 2019-01-08T02:11:49+00:00
End time                 = 2019-01-08T02:12:49+00:00
Elapsed time             = 60 seconds

-- more --, next page: Space, continue: g, quit: ^C

```

Example: show platform

```

SISPM1040-3248-L# show platform ?
  debug  Debug command setting
  phy    PHYs' information
SISPM1040-3248-L# show platform debug

Platform debug command function is denied.

SISPM1040-3248-L# show platform phy
Port  API Inst  WAN/LAN/1G Mode  Duplex  Speed  Link

```

```

-----
1   Default  1G      ANEG    FDX     1G      No
2   Default  1G      ANEG    FDX     1G      No
3   Default  1G      ANEG    FDX     1G      No
4   Default  1G      ANEG    FDX     1G      No
5   Default  1G      ANEG    FDX     1G      No
6   Default  1G      ANEG    FDX     1G      No
7   Default  1G      ANEG    FDX     1G      No
8   Default  1G      ANEG    FDX     1G      No
9   Default  1G      ANEG    FDX     1G      No
10  Default  1G      ANEG    FDX     1G      No
11  Default  1G      ANEG    FDX     1G      No
12  Default  1G      ANEG    FDX     1G      No
13  Default  1G      ANEG    FDX     1G      No
14  Default  1G      ANEG    FDX     1G      No
15  Default  1G      ANEG    FDX     1G      No
16  Default  1G      ANEG    FDX     1G      No
17  Default  1G      ANEG    FDX     1G      No
18  Default  1G      ANEG    FDX     1G      No
19  Default  1G      ANEG    FDX     1G      No
20  Default  1G      ANEG    FDX     1G      No

```

SISPM1040-3248-L#

SISPM1040-3248-L# **show platform phy instance**

Next Restart : Cold

Previous Restart: Cold

Current API Version : 0

Previous API Version: 0

Phy Instance Restart Source:1G

Phy Instance Restart Port:0

Current Phy Start Instance:none

SISPM1040-3248-L#

Example: **show poe** (Power Over Ethernet) data

SISPM1040-3248-L# **show poe ?**

```

auto-power-reset  Show PoE Auto Power Reset configuration.
config            Display PoE (Power Over Ethernet) config for the switch.
power-delay      Display PoE (Power Over Ethernet) power delay for the switch.
profile          poe scheduling profile
reboot           poe reboot scheduling
status           Display PoE (Power Over Ethernet) status for the switch.

```

SISPM1040-3248-L# **show poe??**

show poe auto-power-reset

show poe config [interface (<port_type> [<v_port_type_list>])]

show poe power-delay [interface (<port_type> [<v_port_type_list>])]

show poe profile [id <has_id>]

show poe reboot

show poe status [interface (<port_type> [<v_port_type_list>])]

show poe { auto-check | auto-power-reset } [interface (<port_type> [<v_port_type_list>])]

```
SISPM1040-3248-L# show poe config
```

```
Primary Power Supply [W]      : 370
```

Port	Mode	Schedule	Priority	Max. Power [W]
1	Enabled	Disable	Critical	30.0
2	Enabled	Disable	High	30.0
3	Disabled	Disable	High	30.0
4	Enabled	Disable	Low	30.0
5	Enabled	Disable	Low	30.0
6	Enabled	Disable	Low	30.0
7	Enabled	Disable	Low	30.0
8	Enabled	Disable	Low	30.0
9	Enabled	Disable	Low	30.0
10	Enabled	Disable	Low	30.0
11	Enabled	Disable	Low	30.0
12	Enabled	Disable	Low	30.0
13	Enabled	Disable	Low	30.0
14	Enabled	Disable	Low	30.0
15	Enabled	Disable	Low	30.0
16	Enabled	Disable	Low	30.0
17	Enabled	Disable	Low	30.0
18	Enabled	Disable	Low	30.0
19	Enabled	Disable	Low	30.0
20	Enabled	Disable	Low	30.0
21	Enabled	Disable	Low	30.0
22	Enabled	Disable	Low	30.0
23	Enabled	Disable	Low	30.0
24	Enabled	Disable	Low	30.0

```
GigabitEthernet 1/25 does not have PoE support
GigabitEthernet 1/26 does not have PoE support
GigabitEthernet 1/27 does not have PoE support
GigabitEthernet 1/28 does not have PoE support
10GigabitEthernet 1/1 does not have PoE support
10GigabitEthernet 1/2 does not have PoE support
10GigabitEthernet 1/3 does not have PoE support
10GigabitEthernet 1/4 does not have PoE support
```

```
SISPM1040-3248-L# show poe status
```

Interface	PD Class	Port Status	Pwr
Req Pwr	Alloc Power	Current	Priority
[W]	Used[W]	Used[W]	Used
GigabitEthernet 1/1	1	PoE turned ON	30
30	1.7	33	Low
GigabitEthernet 1/2	1	PoE turned ON	30
30	1.6	31	Low
GigabitEthernet 1/3	-	No PD detected	0

```

 0      0.0    0      Low
GigabitEthernet 1/4    -      No PD detected      0
 0      0.0    0      Low
GigabitEthernet 1/5    -      No PD detected      0
 0      0.0    0      Low
GigabitEthernet 1/6    -      No PD detected      0
 0      0.0    0      Low
GigabitEthernet 1/7    -      No PD detected      0
 0      0.0    0      Low
GigabitEthernet 1/8    -      No PD detected      0
 0      0.0    0      Low
-- more --, next page: Space, continue: g, quit: ^C
GigabitEthernet 1/9    -      No PD detected      0
 0      0.0    0      Low
GigabitEthernet 1/10  -      No PD detected      0
 0      0.0    0      Low
GigabitEthernet 1/11  -      No PD detected      0
 0      0.0    0      Low
GigabitEthernet 1/12  -      No PD detected      0
 0      0.0    0      Low
GigabitEthernet 1/13  -      No PD detected      0
 0      0.0    0      Low
GigabitEthernet 1/14  -      No PD detected      0
 0      0.0    0      Low
GigabitEthernet 1/15  -      No PD detected      0
 0      0.0    0      Low
GigabitEthernet 1/16  -      No PD detected      0
 0      0.0    0      Low
GigabitEthernet 1/17 does not have PoE support
GigabitEthernet 1/18 does not have PoE support
GigabitEthernet 1/19 does not have PoE support
GigabitEthernet 1/20 does not have PoE support
10GigabitEthernet 1/1 does not have PoE support
10GigabitEthernet 1/2 does not have PoE support
Total Power Request : 60.0 [W]
Total Power Alloctaed : 60.0 [W]
Total Power Used : 3.6 [W]
Total Current Used : 68 [mA]
Capacitor Detection : No
SISPM1040-3166-L#

SISPM1040-3248-L# show poe auto-power-reset

Ping Check : Disabled

Port Ping IP Address Start up Interval Retry Failure Log      Failure Action  Reboot
      Time      Time      Time
-----

```

```

1  0.0.0.0      60    30    3  error=0,total=0  Nothing      15
2  0.0.0.0      60    30    3  error=0,total=0  Nothing      15
3  0.0.0.0      60    30    3  error=0,total=0  Nothing      15
4  0.0.0.0      60    30    3  error=0,total=0  Nothing      15
5  0.0.0.0      60    30    3  error=0,total=0  Nothing      15
6  0.0.0.0      60    30    3  error=0,total=0  Nothing      15
-- more --, next page: Space, continue: g, quit: ^C

```

Message: *GigabitEthernet 1/1 does not have PoE support*

Meaning: The power supply does not provide enough power.

Recovery: See the InstallGuide for power supply options and related information.

Example: **show port-security** (Show Port Security overview status)

```

SISPM1040-3248-L# show port-security ?
|          Output modifiers
address    Show MAC Addresses learned by Port Security
interface  Port interface
<cr>
SISPM1040-3248-L# show port-security
Users:
P = Port Security (Admin)
8 = 802.1X
V = Voice VLAN

Interface  Users  Limit  Current  Violating  Violation  Mode  State
-----
Gi 1/1     P--    4      0        0  Restrict  Ready
Gi 1/2     P--    4      0        0  Shutdown Ready
Gi 1/3     P--    4      0        0  Restrict  Ready
Gi 1/4     P--    4      0        0  Protect   Ready
Gi 1/5     P--    4      0        0  Protect   Ready
Gi 1/6     P--    4      0        0  Protect   Ready
Gi 1/7     P--    4      0        0  Protect   Ready
-- more --
Gi 1/19    P--    4      0        0  Protect   Ready
Gi 1/20    P--    4      0        0  Protect   Ready
Gi 1/21    P--    4      0        0  Protect   Ready
Gi 1/22    P--    4      0        0  Protect   Ready
Gi 1/23    P--    4      0        0  Protect   Ready
Gi 1/24    P--    4      0        0  Protect   Ready
Gi 1/25    P--    4      4        0  Protect   Limit Reached
Gi 1/26    P--    4      0        0  Protect   Ready
Gi 1/27    P--    4      0        0  Protect   Ready
Gi 1/28    P--    4      0        0  Protect   Ready
10G 1/1    P--    4      0        0  Protect   Ready
10G 1/2    P--    4      0        0  Protect   Ready
10G 1/3    P--    4      0        0  Protect   Ready
10G 1/4    P--    4      0        0  Protect   Ready

```

```
Aging time: 3000 seconds
Hold time: 200 seconds
```

```
SISPM1040-3248-L#
```

Example: **show privilege** (Display command privilege)

```
SISPM1040-3248-L# show privilege ?
|      Output modifiers
<cr>
SISPM1040-3248-L# show privilege | ?
begin      Begin with the line that matches
exclude    Exclude lines that match
include    Include lines that match
SISPM1040-3248-L#
```

Example: **show process** (process load / process list)

```
SISPM1040-3248-L# show process load
2.29 2.11 2.03 1/218 346
SISPM1040-3248-L# show process list
PID  USER      COMMAND
  1  root      /usr/bin/stage2-loader
  2  root      [kthreadd]
  3  root      [ksoftirqd/0]
  4  root      [kworker/0:0]
  5  root      [kworker/0:0H]
  6  root      [kworker/u2:0]
  7  root      [lru-add-drain]
  8  root      [kdevtmpfs]
  9  root      [oom_reaper]
 10  root      [writeback]
 11  root      [kcompactd0]
 12  root      [crypto]
 13  root      [bioset]
 14  root      [kblockd]
.....
 61  root      [ipv6_addrconf]
 62  root      [ubi_bgt0d]
 63  root      [ubifs_bgt0_0]
 64  root      [loop0]
 65  root      [kworker/0:1H]
 66  root      [kworker/u2:1]
 67  root      [loop1]
 68  root      [loop2]
 69  root      /bin/sh -c /usr/bin/switch_app
 70  root      /usr/bin/switch_app
145  root      /usr/sbin/zebra -f /etc/quagga/zebra.conf -i /tmp/zebra.pid -P 0
181  root      /usr/sbin/dropbear -r /switch//dropbear_rsa_host_key -p 22 -j -k
313  nobody    hiawatha -d -c /tmp/hiawatha
```

```

347 root    /bin/sh -c ps
348 root    ps
SISPM1040-3248-L#

```

Example: **show ptp** (Precision time Protocol) (1588)

```

SISPM1040-3248-L# show ptp ?
<0-3>          Show various PTP data
cal            Show the PTP calibration.
ext           Show the 1PPS and External clock output configuration and
              VCXO frequency rate adjustment option.
ms-pdv        Show the configuration of the MS-PDV.
rs422         This command shows the configuration of the alternative
              clock, that is connected to the RS422 connector.
servo
system-time   Show the PTP <-> system time synchronization mode.
SISPM1040-3248-L# show ptp 0 ?
clk           Show PTP slave clock options parameters.
current       Show PTP current data set (IEEE1588 paragraph 8.2.2).
default       Show PTP default data set (IEEE1588 paragraph 8.2.1).
filter        Show PTP filter parameters.
filter-type   Show PTP filter type
foreign-master-record Show PTP port foreign masters.
ho            Show PTP slave holdover parameters.
local-clock   Show local clock current time
log-mode      Show PTP log mode.
master-table-unicast Show PTP master list of connected unicast slaves.
parent        Show PTP parent data set (IEEE1588 paragraph 8.2.3).
port-ds       Show PTP port data set (IEEE1588 paragraph 8.2.5).
port-state    Show PTP port state.
port-statistics Show PTP port statistics.
servo         Show PTP servo parameters.
slave         Show PTP slave clock lock threshold parameters.
.....

SISPM1040-3248-L# show ptp 0 clk
Option threshold 'P'constant
-----
SISPM1040-3248-L# show ptp 0 current
stpRm OffsetFromMaster MeanPathDelay
-----
SISPM1040-3248-L# show ptp 0 current
stpRm OffsetFromMaster MeanPathDelay
-----
0      0.000,000,000    0.000,000,000
SISPM1040-3248-L# show ptp 0 clk
Option threshold 'P'constant
-----
free   1000    2
SISPM1040-3248-L#

```

Example: **show pvlan** (Private VLAN) configuration

```
SISPM1040-3248-L# show pvlan ?
  <range_list>  PVLAN ID to show configuration for
  isolation      show isolation configuration
  <cr>
SISPM1040-3248-L# show pvlan?
  pvlan         PVLAN configuration
  <cr>
SISPM1040-3248-L# show pvlan??
show pvlan [ <pvlan_list> ]
show pvlan isolation [ interface ( <port_type> [ <plist> ] ) ]
SISPM1040-3248-L# show pvlan
PVLAN ID  Ports
-----
1          GigabitEthernet 1/1, GigabitEthernet 1/2, GigabitEthernet 1/3,
          GigabitEthernet 1/4, GigabitEthernet 1/5, GigabitEthernet 1/6,
          GigabitEthernet 1/7, GigabitEthernet 1/8, GigabitEthernet 1/9,
          GigabitEthernet 1/10, GigabitEthernet 1/11, GigabitEthernet 1/12,
          GigabitEthernet 1/13, GigabitEthernet 1/14, GigabitEthernet 1/15,
          GigabitEthernet 1/16, GigabitEthernet 1/17, GigabitEthernet 1/18,
          GigabitEthernet 1/19, GigabitEthernet 1/20, GigabitEthernet 1/21,
          GigabitEthernet 1/22, GigabitEthernet 1/23, GigabitEthernet 1/24,
          GigabitEthernet 1/25, GigabitEthernet 1/26, GigabitEthernet 1/27,
          GigabitEthernet 1/28, 10GigabitEthernet 1/1, 10GigabitEthernet 1/2,
          10GigabitEthernet 1/3, 10GigabitEthernet 1/4
SISPM1040-3248-L#
```

Example: **show qos** (Quality of Service)

```
SISPM1040-3248-L# show qos ?
|          Output modifiers
interface  Interface
maps       QoS Maps/Tables
qce        QoS Control Entry
storm      Storm policer
wred       Weighted Random Early Discard
<cr>
SISPM1040-3248-L# show qos?
qos        Quality of Service
<cr>
SISPM1040-3248-L# show qos?
show qos [ { interface [ ( <port_type> [ <port> ] ) ] } | wred | { maps [ dscp-cos ] [ dscp-
ingress-translation ] [ dscp-classify ] [ cos-dscp ] [ dscp-egress-translation ] [ { ingress
[ <ing_id> ] } ] [ { egress [ <egr_id> ] } ] } | storm | { qce [ <qce> ] } ]
show qos frame-preemption status [ interface ( <port_type> [ <port> ] ) ]
show qos sfi statistics [ <sfi_id> ]
show qos sgi status [ <sgi_id> ]
show qos spt
show qos tas status [ interface ( <port_type> [ <port> ] ) ]
SISPM1040-3248-L# show qos
interface GigabitEthernet 1/1
qos cos 0
qos pcp 0
qos dpl 0
qos dei 0
qos class 0
qos trust tag disabled
qos map tag-cos pcp 0 dei 0 cos 1 dpl 0
qos map tag-cos pcp 0 dei 1 cos 1 dpl 1
qos map tag-cos pcp 1 dei 0 cos 0 dpl 0
qos map tag-cos pcp 1 dei 1 cos 0 dpl 1
qos map tag-cos pcp 2 dei 0 cos 2 dpl 0
qos map tag-cos pcp 2 dei 1 cos 2 dpl 1
qos map tag-cos pcp 3 dei 0 cos 3 dpl 0
qos map tag-cos pcp 3 dei 1 cos 3 dpl 1
qos map tag-cos pcp 4 dei 0 cos 4 dpl 0
qos map tag-cos pcp 4 dei 1 cos 4 dpl 1
qos map tag-cos pcp 5 dei 0 cos 5 dpl 0
qos map tag-cos pcp 5 dei 1 cos 5 dpl 1
qos map tag-cos pcp 6 dei 0 cos 6 dpl 0
qos map tag-cos pcp 6 dei 1 cos 6 dpl 1
qos map tag-cos pcp 7 dei 0 cos 7 dpl 0
-- more --, next page: Space, continue: g, quit: ^C
```

Example: **show radius-server** (RADIUS configuration)

```
SISPM1040-3248-L# show radius-server ?
|           Output modifiers
statistics  RADIUS statistics
<cr>
SISPM1040-3248-L# show radius-server?
radius-server  RADIUS configuration
<cr>
SISPM1040-3248-L# show radius-server??
show radius-server [ statistics ]
SISPM1040-3248-L# show radius-server
Global RADIUS Server Timeout      : 5 seconds
Global RADIUS Server Retransmit   : 3 times
Global RADIUS Server Deadtime     : 0 minutes
Global RADIUS Server Key          :
Global RADIUS Server Attribute 4  :
Global RADIUS Server Attribute 95 :
Global RADIUS Server Attribute 32 :
No servers configured!
SISPM1040-3248-L#
```

Example: **show rapid-ring**

```
SISPM1040-3248-L# show rapid-ring
Entry Index          : 1
Rapid Ring Role      : Disabled
Rapid Ring Port 1    : 25
Rapid Ring Port 2    : 26
Rapid Ring Port 1 State : Forwarding
Rapid Ring Port 2 State : Forwarding

Entry Index          : 2
Rapid Ring Role      : Disabled
Rapid Ring Port 1    : 27
Rapid Ring Port 2    : 28
Rapid Ring Port 1 State : Forwarding
Rapid Ring Port 2 State : Forwarding

Entry Index          : 3
Rapid Ring Role      : Disabled
Rapid Ring Port 1    : 29
Rapid Ring Port 2    : 30
Rapid Ring Port 1 State : Forwarding
Rapid Ring Port 2 State : Forwarding

Entry Index          : 4
Rapid Ring Role      : Disabled
Rapid Ring Port 1    : 31
Rapid Ring Port 2    : 32
```

```
Rapid Ring Port 1 State : Forwarding
Rapid Ring Port 2 State : Forwarding
```

```
SISPM1040-3248-L#
```

Example: **show rfc2544** (RFC2544 performance tests – in Exec mode):

```
SISPM1040-3166-L# show rfc2544 ?
  profile  Display specific profile or a list of defined profiles.
  report   Display specific report or a list or reports
SISPM1040-3166-L# show rfc2544?
show rfc2544 profile [ <profile_name> ]
show rfc2544 report [ <report_name> ]
SISPM1040-3166-L# show rfc2544 profile NewProfile
```

Common configuration:

```
Profile name       : NewProfile
Description        : rfc2544-1
DST is OAM aware  : No
MEG Level          : 7
Egress interface  : GigabitEthernet 1/9
Sequence number check: Disabled
Dwell time        : 2000 milliseconds
Type              : Port Down-MEP
Destination MAC    : 00-00-00-00-00-01
Source MAC         : 00-c0-f2-49-3a-29
Frame sizes        : 64 128 256 512 1024 1280 1518 2000
Throughput test    : Enabled
Latency test       : Enabled
Frame loss test    : Disabled
Back-to-back test  : Disabled
```

Throughput configuration:

```
Trial duration     : 60 seconds
Minimum rate       : 800 permille
Maximum rate       : 1000 permille
Accuracy           : 2 permille
Allowed frame loss : 0 permille
```

Latency configuration:

```
Trial duration     : 120 seconds
Delay meas. interval : 10000 milliseconds
Allowed frame loss  : 0 permille
```

```
SISPM1040-3166-L# show rfc2544 report ?
|           Output modifiers
<word32>    Name of existing report to display.
<cr>
SISPM1040-3166-L# show rfc2544 report
```

Report Name	Created	Status
-------------	---------	--------

<No reports>

SISPM1040-3166-L#

Example: **show rmon** (RMON statistics)

```
SISPM1040-3248-L# show rmon ?
```

```
  alarm      Display the RMON alarm table
  event      Display the RMON event table
  history    Display the RMON history table
  statistics  Display the RMON statistics table
```

```
SISPM1040-3248-L# show rmon?
```

```
  rmon      RMON statistics
```

```
SISPM1040-3248-L# show rmon?
```

```
show rmon alarm [ <id_list> ]
```

```
show rmon event [ <id_list> ]
```

```
show rmon history [ <id_list> ]
```

```
show rmon statistics [ <id_list> ]
```

```
SISPM1040-3248-L# show rmon alarm
```

```
SISPM1040-3248-L# show rmon statistics
```

```
SISPM1040-3248-L#
```

Example: **show running-config** (running system information)

```

SISPM1040-3248-L# show running-config ?
|                Output modifiers
all-defaults     Include most/all default values
feature          Show configuration for specific feature
interface        Show specific interface or interfaces
line             Show line settings
vlan             VLAN
<cr>
SISPM1040-3248-L# show running-config?
running-config  Show running system information
<cr>
SISPM1040-3248-L# show running-config?
show running-config [ all-defaults ]
show running-config feature <feature_name> [ all-defaults ]
show running-config interface ( <port_type> [ <list> ] ) [ all-defaults ]
show running-config interface vlan <list> [ all-defaults ]
show running-config line { console | vty } <list> [ all-defaults ]
show running-config vlan { [ <vlan_list> ] } [ all-defaults ]
SISPM1040-3248-L# show running-config
Building configuration...
hostname SISPM1040-3248-L
username admin privilege 15 password encrypted c6fbf181f412a65f858eae8347c903e38
a3bfce7949e099f1f7e76b89d4c59a84c35fd070d4cb584cf74b20be619275f6d39ab69e0b37bcd5
ec0af3e703e2c09
system name SISPM1040-3248-L
system description Managed Hardened PoE+ Switch, (24) 10/100/1000Base-T PoE+ ports + (4)
100/1000Base-X SFP/RJ-45 Combo + (4) 1G/10G SFP+
evc 1 vid 1 ivid 10 learning nni ingress-map 1 egress-map 0
!
vlan 1
!
!
!
!
ip route 0.0.0.0 0.0.0.0 192.168.1.254
mvr
mvr vlan 10 name MVRCFG1
spanning-tree mst name 00-c0-f2-49-39-b4 revision 0
!
ptp ext output auto
-- more --, next page: Space, continue: g, quit: ^C

```

Example: **show sflow** (Statistics flow)

```
SISPM1040-3248-L# show sflow ?
|           Output modifiers
statistics  sFlow statistics.
<cr>
SISPM1040-3248-L# show sflow?
sflow      Statistics flow.
<cr>
SISPM1040-3248-L# show sflow?
show sflow
show sflow statistics { receiver [ <rcvr_idx_list> ] | samplers [ interface [ <s
amplers_list> ] ( <port_type> [ <v_port_type_list> ] ) ] }
SISPM1040-3248-L# show sflow
```

Agent Configuration:

=====

Agent Address: 127.0.0.1

Receiver Configuration:

=====

```
Owner       : <none>
Receiver    : 0.0.0.0
UDP Port    : 6343
Max. Datagram: 1400 bytes
Time left   : 0 seconds
```

No enabled collectors (receivers). Skipping displaying per-port info.

SISPM1040-3248-L#

Example: **show smtp** (Show email information)

```
SISPM1040-3248-L# show smtp ?
<cr>
SISPM1040-3248-L# show smtp
Mail Server      :
User Name       :
Password        :
Sender          :
Return Path     :
Email Address 1 :
Email Address 2 :
Email Address 3 :
Email Address 4 :
Email Address 5 :
Email Address 6 :
SISPM1040-3248-L#
```

Example: **show snmp** (Set SNMP server's configurations)

```
SISPM1040-3248-L# show snmp ?
|                               Output modifiers
access                          access configuration
community                       Community
host                            Set SNMP host's configurations
info                            information
mib                             MIB (Management Information Base)
security-to-group               security-to-group configuration
trap                            Set SNMP host's configurations
user                            User
view                            MIB view configuration
<cr>

SISPM1040-3248-L# show snmp??
show snmp
show snmp access [ <group_name> [ { v1 | v2c | v3 | any } [ { auth | noauth | priv } ] ] ]
show snmp community [ <community> ]
show snmp host [ <conf_name> ]
show snmp mib context
show snmp mib ifmib ifIndex [ port ] [ aggregation ] [ vlan ]
show snmp security-to-group [ { v1 | v2c | v3 } [ <security_name> ] ]
show snmp trap [ <source_name> ]
show snmp user [ <username> [ <engineID> ] ]
show snmp view [ <view_name> [ <oid_subtree> ] ]
SISPM1040-3248-L# show snmp

SNMP Configuration
SNMP Mode : enabled
Engine ID : 800014550300c0f24939b4

SNMPv3 Communities Table:
Community/Security Name : public
Source IP                : 0.0.0.0/0
Community secret        : public

Community/Security Name : private
Source IP                : 0.0.0.0/0
Community secret        : private

SNMPv3 Users Table:

SNMPv3 Groups Table;
Security Model : v1
Security Name  : public
Group Name    : default_ro_group

-- more --, next page: Space, continue: g, quit: ^C
```

```
SISPM1040-3248-L# show snmp info
```

```
SNMP Info:
```

```
Conf VendorName:TN, VENDOR_TN, PRODUCT:SISPM1040-3248-L
```

```
EngineID: 800014550300c0f2493f8f
```

```
Using oid :1.3.6.1.4.1.868.2.80.7, length:10
```

```
SISPM1040-3248-L#
```

Example: **show spanning-tree** (STP Bridge)

```
SISPM1040-3248-L# show spanning-tree ?
```

```
active          STP active interfaces
```

```
detailed       STP statistics
```

```
interface      Choose port
```

```
mst            Multiple STP
```

```
root-guard     STP Root Guard
```

```
summary        STP summary
```

```
spanning-tree  STP Bridge
```

```
SISPM1040-3248-L# show spanning-tree??
```

```
show spanning-tree [ { root-guard [ interface ( <port_type> [ <v_port_type_list_r> ] ) ] } |
summary | active | { interface ( <port_type> [ <v_port_type_list> ] ) } | { detailed [ interface
( <port_type> [ <v_port_type_list_1> ] ) ] } | { mst [ configuration | { <instance> [ interface (
<port_type> [ <v_port_type_list_2> ] ) ] } ] } ] }
```

```
SISPM1040-3248-L# show spanning-tree
```

```
CIST Bridge STP Status
```

```
Bridge ID      : 32768.00-C0-F2-49-39-B4
```

```
Root ID       : 32768.00-C0-F2-49-39-B4
```

```
Root Port    : -
```

```
Root PathCost: 0
```

```
Regional Root: 32768.00-C0-F2-49-39-B4
```

```
Int. PathCost: 0
```

```
Max Hops     : 20
```

```
TC Flag      : Steady
```

```
TC Count     : 0
```

```
TC Last      : -
```

Port	Port Role	State	Pri	PathCost	Edge	P2P	Uptime
Gi 1/1	DesignatedPort	Forwarding	128	20000	Yes	Yes	0d 19:08:26

```
SISPM1040-3248-L#
```

Example: **show svl** (Shared VLAN Learning configuration)

```
SISPM1040-3248-L# show svl ?
|      Output modifiers
fid    Show a given FID
vlan   Show a given VLAN ID
<cr>

SISPM1040-3248-L# show svl??
show svl { [ fid [ <fid_list> ] ] | [ vlan [ <vlan_list> ] ] }
SISPM1040-3248-L# show svl fid ?
|      Output modifiers
<1~4095> List of FIDs to show
<cr>

SISPM1040-3248-L# show svl fid 1 ?
|      Output modifiers
<cr>

SISPM1040-3248-L# show svl fid 1
FID  VLANs
-----
  1  1 (default)
SISPM1040-3248-L# show svl vlan ?
|      Output modifiers
<vlan_list> List of VIDs to show
<cr>

SISPM1040-3248-L# show svl vlan
VLAN  FID
-----
None
SISPM1040-3248-L#
```

Example: **show switchport** (display switching mode characteristics)

```
SISPM1040-3248-L# show switchport forbidden ?
|      Output modifiers
name   Forbidden VLANs by VLAN name
vlan   Forbidden VLAN by VLAN ID
<cr>

SISPM1040-3248-L# show switchport forbidden?
forbidden Lookup VLAN Forbidden port entry.
<cr>

SISPM1040-3248-L# show switchport forbidden?
show switchport forbidden [ { vlan <vlan_list> } | { name <name> } ]
SISPM1040-3248-L# show switchport forbidden
% No forbidden VLANs found
SISPM1040-3248-L#
```

Example: **show system** (system information)

```
SISPM1040-3248-L# show system cpu status
```

```
Average load in 100 ms : 27%
```

```
Average load in 1 sec : 11%
```

```
Average load in 10 sec : 40%
```

```
SISPM1040-3248-L# show system di-do
```

```
Switch DI Mode: Low
```

```
Switch DO Mode: close
```

```
SISPM1040-3248-L# show system reboot
```

```
Switch Reboot Mode: Disable
```

```
Switch Reboot Entry:
```

	Reboot Time
Week Day	HH : MM
Monday	- -
Tuesday	- -
Wednesday	- -
Thursday	- -
Friday	- -
Saturday	- -
Sunday	- -

```
SISPM1040-3248-L# show system
```

```
Model Name : SISPM1040-3248-L
```

```
System Description : Managed Hardened PoE+ Switch, (24) 10/100/1000Base-T PoE+ ports  
+ (4) 100/1000Base-X SFP + (4) 1G/10G SFP+
```

```
Location :
```

```
Contact :
```

```
System Name : SISPM1040-3248-L
```

```
System Date : 2016-01-01T19:30:31+00:00
```

```
System Uptime : 19:30:58
```

```
Bootloader Version : V1.01
```

```
Firmware Version : v8.50.0149 2024-05-14
```

```
PoE Firmware Version : 000-000
```

```
Hardware Version : v1.02
```

```
Mechanical Version : v1.01
```

```
Serial Number : A139119BR2500001
```

```
MAC Address : 00-c0-f2-49-3f-8f
```

```
Memory : Total=7648 KBytes, Free=1205 KBytes
```

```
Powers Status : Normal
```

```
Temperature Status : Normal
```

```
Temperature 1 : 43(C) ; 109(F)
```

```
Temperature 2 : 42(C) ; 107(F)
```

```
SISPM1040-3248-L#
```

Example: **show tacacs-server** (TACACS+ configuration)

```
SISPM1040-3248-L# show tacacs-server
Global TACACS+ Server Timeout      : 5 seconds
Global TACACS+ Server Deadtime    : 0 minutes
Global TACACS+ Server Key         : 323e185f148186c4a68442ea12f9c6e5ef5c18cb498
1308c0c44f7c785ad14ba27c36ee81c5ed8794e786e9a5d72c6325b3c55b9949c61b94a604c2b6ad7e79a
TACACS+ Server #1:
  Host name   : 192.168.1.77
  Port        : 49
  Timeout     : 60 seconds
  Key         : de49571cf9acc8c65dff6e6d51545c55eddd9048c99e6a23d61b06b5c49b5632a
bbf5d963d7668e803f413e8f9f75109ac6c0850842bc567993251339a5c358a
SISPM1040-3248-L#
```

Example: **show terminal** (terminal configuration parameters)

```
SISPM1040-3248-L# show terminal
Line is vty 0.
-----
* You are at this line now.
Alive from Telnet.
Default privileged level is 2.
Command line editing is enabled
Display EXEC banner is enabled.
Display Day banner is enabled.
Terminal width is 80.
    length is 24.
    history size is 32.
    exec-timeout is 10 min 0 second.

Current session privilege is 15.
Elapsed time is 0 day 0 hour 0 min 53 sec.
Idle time is 0 day 0 hour 0 min 0 sec.

SISPM1040-3248-L#
```

Example: **show traffic-test-loop**

```
SISPM1040-3166-L# show traffic-test-loop ?
|          Output modifiers
<range_list> The range of traffic-test-loop instances
ll         Show Latching Loopback state
<cr>

SISPM1040-3166-L# show traffic-test-loop?
traffic-test-loop Traffic Test Loop that can do looping to used for
                  traffic testing like RFC2544 and Y.1564.

<cr>
SISPM1040-3166-L# show traffic-test-loop??
show traffic-test-loop [ <inst> ] [ ll ]

SISPM1040-3248-L# show traffic-test-loop
```

Traffic Test Loop:

inst	flow	name	type	opctrl	direction	do
main	port	level	subscriber	vid	admin	oper
1	-	TRAFFIC_TEST_LOOP_INSTANCE GigabitEthernet 1/1	mac-loop	static	facility	up
2	-	TRAFFIC_TEST_LOOP_INSTANCE GigabitEthernet 1/1	mac-loop	static	facility	down
3	1	TRAFFIC_TEST_LOOP_INSTANCE GigabitEthernet 1/1	mac-loop	latch-1	facility	inact
4	1	TRAFFIC_TEST_LOOP_INSTANCE GigabitEthernet 1/1	mac-loop	latch-1	facility	inact
5	1	TRAFFIC_TEST_LOOP_INSTANCE GigabitEthernet 1/1	oam-loop	static	facility	down

-- more --, next page: Space, continue: g, quit: ^C

SISPM1040-3248-L# **show traffic-test-loop ll**

Traffic Test Latching Loop:

inst	mep	smac	admin	oper	timer
3	128	00-00-00-00-00-00	enabled	inactive	0s
4	128	00-00-00-00-00-00	enabled	inactive	0s

SISPM1040-3248-L#

Example: **show udld** (Unidirectional Link Detection) configurations, statistics and status

SISPM1040-3248-L# **show udld ?**

```

|          Output modifiers
interface  Choose port
<cr>

```

SISPM1040-3248-L# **show udld?**

show udld [interface (<port_type> [<plist>])]

SISPM1040-3248-L# **show udld**

GigabitEthernet 1/1

```

-----
UDLD Mode          : Disable
Admin State        : Disable
Message Time Interval(Sec): 7
Device ID(local)   : 00-C0-F2-49-39-B4
Device Name(local) : SISPM1040-3248-L
Bidirectional state : Indeterminant

```

No neighbor cache information stored

```
-----
GigabitEthernet 1/2
-----
```

```
UDLD Mode           : Disable
Admin State         : Disable
Message Time Interval(Sec): 7
Device ID(local)    : 00-C0-F2-49-39-B4
Device Name(local)  : SISPM1040-3248-L
Bidirectional state : Indeterminant
```

```
-- more --, next page: Space, continue: g, quit: ^C
```

Example: **show upnp** (display UPnP configuration)

```
SISPM1040-3248-L# show upnp?
  upnp    Display UPnP configuration
  <cr>
SISPM1040-3248-L# show upnp
UPnP Mode           : disabled
UPnP TTL            : 4
UPnP Advertising Duration : 100
UPnP IP Addressing Mode : dynamic
UPnP Static IP Interface ID : 1
SISPM1040-3248-L#
```

Example: **show user-privilege** (Users privilege) configuration

```
SISPM1040-3248-L# show user-privilege ?
  <cr>
SISPM1040-3248-L# show user-privilege
username admin privilege 15 password encrypted c6fbf181f412a65f858eae8347c903e38
a3bfce7949e099f1f7e76b89d4c59a84c35fd070d4cb584cf74b20be619275f6d39ab69e0b37bcd5
ec0af3e703e2c09
SISPM1040-3248-L#
```

Example: **show users** (display information about terminal lines)

```
SISPM1040-3248-L# show users ?
  |      Output modifiers
  myself  Display information about mine
  <cr>
SISPM1040-3248-L# show users?
show users [ myself ]
SISPM1040-3248-L# show users
Line is vty 0.
  * You are at this line now.
  Connection is from 192.168.1.99:49588 by Telnet.
  User name is admin.
```

```
Privilege is 15.  
Elapsed time is 0 day 0 hour 7 min 42 sec.  
Idle time is 0 day 0 hour 0 min 0 sec.
```

```
SISPM1040-3248-L#
```

Example: **show version** (system hardware and software status)

```
SISPM1040-3248-L# show version brief
```

```
Version      : SISPM1040-3248-L (standalone) v8.50.0149  
Build Date   : 2024-05-14T14:52:53+08:00  
SISPM1040-3248-L# show version
```

```
MAC Address   : 00-c0-f2-49-3f-8f  
Previous Restart : Cold
```

```
System Contact  :  
System Name    : SISPM1040-3248-L  
System Location :  
System Time    : 2016-01-01T19:34:07+00:00  
System Uptime  : 19:34:34
```

```
Bootloader
```

```
-----  
Version       : version V1.01  
Date          : 13:31:42, Oct 8 2018
```

```
Active Image
```

```
-----  
Image         : linux (primary)  
Version       : SISPM1040-3248-L (standalone) v8.50.0149  
Date          : 2021-05-11T14:52:53+08:00
```

```
Backup Image
```

```
-----  
Image         : linux.bk (backup)  
Version       : SISPM1040-3248-L (standalone) v8.50.0032  
Date          : 2021-02-04T12:32:27+08:00
```

```
SISPM1040-3248-L#
```

Example: **show vlan** (VLAN status)

```
SISPM1040-3248-L# show vlan ?
  all          Show all VLANs (if left out only access VLANs are shown)
  brief       VLAN summary information
  id          VLAN status by VLAN id
  ip-subnet   Show VCL IP Subnet entries.
  mac         Show VLAN MAC entries.
  membership  VLAN membership
  name        VLAN status by VLAN name
  protocol    Protocol-based VLAN status
  status      Show the VLANs configured for each interface.
<cr>
SISPM1040-3248-L# show vlan?
  vlan      VLAN status
<cr>
SISPM1040-3248-L# show vlan??
show vlan [ id <vlan_list> | name <name> | brief ] [ all ]
show vlan ip-subnet [ <ipv4> ]
show vlan mac [ address <mac_addr> ]
show vlan membership [ id <vlan_list> | name <name> ] [ admin | combined | erps | evc | gvrp
| mep | mstp | mvr | nas | rmirror | vcl | voice-vlan | forbidden ]

show vlan protocol [ eth2 { <etype> | arp | ip | ipx | at } ] [ snap { <oui> | rfc-1042 |
snap-8021h } <pid> ] [ llc <dsap> <ssap> ]
show vlan status [ interface ( <port_type> [ <plist> ] ) ] [ admin | all | combined |
conflicts | erps | evc | gvrp | mep | mstp | mvr | nas | rmirror | vcl | voice-vlan ]
SISPM1040-3248-L# show vlan
VLAN Name                               Interfaces
-----
1    default                               Gi 1/1-28 10G 1/1-4

SISPM1040-3248-L# show vlan status
GigabitEthernet 1/1 :
-----
VLAN User   PortType      PVID  Frame Type   Ing Filter  Tx Tag      UVID  Conflicts
-----
Combined    C-Port        1     All          Enabled     None        1     No
Admin       C-Port        1     All          Enabled     None        1     No
NAS
GVRP
MVR
Voice VLAN
MSTP
ERPS
-- more --, next page: Space, continue: g, quit: ^C
```

Example: **show voice** (Voice appliance attributes)

```

SISPM1040-3248-L# show voice vlan ?
|          Output modifiers
interface  Select an interface to configure
oui        OUI configuration
<cr>
SISPM1040-3248-L# show voice vlan?
vlan      VLAN for voice traffic
<cr>
SISPM1040-3248-L# show voice vlan?
show voice vlan [ oui [ <oui> ] | interface ( <port_type> [ <port_list> ] ) ]
SISPM1040-3248-L# show voice vlan
Switch voice vlan is disabled
Switch voice vlan ID is 1000
Switch voice vlan aging-time is 86400 seconds
Switch voice vlan traffic class is 7

Telephony OUI  Description
-----  -----

Voice VLAN switchport is configured on following:

GigabitEthernet 1/1 :
-----
GigabitEthernet 1/1 switchport voice vlan mode is disabled
GigabitEthernet 1/1 switchport voice security is disabled
GigabitEthernet 1/1 switchport voice discovery protocol is oui

GigabitEthernet 1/2 :
-----
GigabitEthernet 1/2 switchport voice vlan mode is disabled
GigabitEthernet 1/2 switchport voice security is disabled
GigabitEthernet 1/2 switchport voice discovery protocol is oui

-- more --, next page: Space, continue: g, quit: ^C

```

Example: **show watchdog** mode

```

SISPM1040-3248-L# show watchdog mode
Watchdog Status : Enable
SISPM1040-3248-L#

```

Example: **show web privilege**

```
SISPM1040-3248-L# show web privilege ?
  group      Web privilege group
SISPM1040-3248-L# show web privilege group ?
  <word>     Valid words are 'Aggregation' 'DHCP' 'DHCPv6_Client'
            'DMS_Trouble_Shooting' 'DMS_Vbatch' 'DMS_client' 'DMS_server'
            'Debug' 'Diagnostics' 'EPS' 'ERPS' 'ETH_LINK_OAM' 'FRR'
            'Firmware' 'Green_Ethernet' 'IP' 'IPMC_Snooping'
            'Install_Wizard' 'LACP' 'LLDP' 'Loop_Protect' 'MAC_Table' 'MEP'
            'MRP' 'MVR' 'Miscellaneous' 'NTP' 'POE' 'PTP' 'Ports'
            'Private_VLANs' 'QoS' 'RMirror' 'SMTP' 'Security(access)'
            'Security(network)' 'Spanning_Tree' 'System' 'Trap_Event' 'UDLD'
            'UPnP' 'VCL' 'VLAN_Translation' 'VLANs' 'Voice_VLAN' 'Watchdog'
            'XXRP' 'sFlow' 'uFDMA_AIL' 'uFDMA_CIL'
  level     Web privilege group level

SISPM1040-3248-L# show web privilege group uFDMA_CIL level ?
  |         Output modifiers
  <cr>
SISPM1040-3248-L# show web privilege group uFDMA_CIL level
Group Name          Privilege Level
                   CRO CRW
-----
uFDMA_CIL           5 10
SISPM1040-3248-L# show web privilege group DMS_Trouble_Shooting level ?
  |         Output modifiers
  <cr>
SISPM1040-3248-L# show web privilege group DMS_Trouble_Shooting level
Group Name          Privilege Level
                   CRO CRW
-----
DMS_Trouble_Shooting 5 10
SISPM1040-3248-L#
```

Example: **show y1564** (Y.1564 service activation tests)

```
SISPM1040-3166-L# show y1564?
  y1564    Y.1564 service activation tests
SISPM1040-3166-L# show y1564??
show y1564 profile [ <profile_name> ]
show y1564 report [ <report_name> ]
SISPM1040-3166-L# show y1564 ?
  profile  Display specific profile or a list of defined profiles.
  report   Display specific report or a list or reports
SISPM1040-3166-L# show y1564 profile
```

Profile Name	Description
NewProfile	y1564-1

```
SISPM1040-3166-L# show y1564 report
```

Report Name	Created	Status
<No reports>		

```
SISPM1040-3166-L#
```

Messages:

% No such report

% No such profile

Chapter 27 Terminal Commands

Command: terminal

Description: Set terminal line parameters.

Syntax: **terminal** editing
terminal exec-timeout <min> [<sec>]
terminal help
terminal history size <history_size>
terminal length <lines>
terminal width <width>

Parameters:	editing	Enable command line editing
	exec-timeout	Set the EXEC timeout
	help	Description of the interactive help system
	history	Control the command history function
	length	Set number of lines on a screen
	width	Set width of the display terminal
	size	Set history buffer size
	<0-32>	Number of history commands, 0 means disable
	<0-1440>	Timeout in minutes
	<0,3-512>	Number of lines on screen (0 for no pausing)
	<0,40-512>	Number of characters on a screen line (0 for unlimited width)

Example:

```
SISPM1040-3248-L# terminal exec-timeout 1440
```

```
SISPM1040-3166-L# terminal editing
```

```
SISPM1040-3166-L# terminal history size 22
```

```
SISPM1040-3166-L# show terminal
```

```
Line is vty 0.
```

```
-----
```

```
* You are at this line now.
```

```
Alive from Telnet.
```

```
Default privileged level is 2.
```

```
Command line editing is enabled
```

```
Display EXEC banner is enabled.
```

```
Display Day banner is enabled.
```

```
Terminal width is 80.
```

```
length is 24.
```

```
history size is 22.
```

```
exec-timeout is 1440 min 0 second.
```

```
Current session privilege is 15.
```

```
Elapsed time is 0 day 0 hour 16 min 30 sec.
```

```
Idle time is 0 day 0 hour 0 min 0 sec.
```

```
SISPM1040-3166-L#
```

Chapter 28 Traceroute Commands

Command: `traceroute`

Description: Send IP Traceroute messages

Syntax:

```
traceroute ip { <domain_name> | <ip_addr> } [ dscp <dscp> ] [ timeout <timeout> ] [ { saddr <src_addr> | sif { <port_type> <src_if> | vlan <vlan_id> } } ] [ probes <probes> ] [ firstttl <firstttl> ] [ maxttl <maxttl> ] [ icmp ] [ numeric ]
```

```
traceroute ipv6 { <domain_name> | <ip_addr> } [ dscp <dscp> ] [ timeout <timeout> ] [ saddr <src_addr> ] [ sif { <port_type> <src_if> | vlan <vlan_id> } ] [ probes <probes> ] [ maxttl <maxttl> ] [ numeric ]
```

Parameters:

ip	Traceroute (IPv4)
ipv6	Traceroute (IPv6)
<domain_name>	Destination hostname or FQDN
<ipv4_addr>	Destination IPv4 address
dscp	Specify DSCP value (default 0)
firstttl	Specify first number of hops (starting TTL) (default 1)
icmp	Use ICMP instead of UDP
maxttl	Specify max number of hops (max TTL) (default 30)
numeric	Print numeric addresses
probes	Specify number of probes per hop (default 3)
saddr	Send from interface with source address
sif	Send from specified interface
timeout	Specify time to wait for a response in seconds (default 3)
<1-255>	Max number of hops (default 30)
GigabitEthernet	1 Gigabit Ethernet Port
10GigabitEthernet	10 Gigabit Ethernet Port
vlan	Send from VLAN interface with source address
<port_type_id>	Port ID in 1/1-4
<1-60>	Number of probes per hop (default 3)
<1-86400>	Time to wait for a response in seconds (default 3)
<ipv4_addr>	Source Address of interface
<0-63>	DSCP value (decimal value, default 0)
<1-30>	First number of hops (default 1)
<domain_name>	Destination hostname or FQDN
<ipv6_addr>	Destination IPv6 address

Example:

```
SISPM1040-3248-L# traceroute ip 192.168.1.1 probes 3
traceroute to 192.168.1.1 (192.168.1.1), 30 hops max, 38 byte packets
 1 192.168.1.77 (192.168.1.77) 3068.382 ms !H 3062.788 ms !H 3070.778 ms !H
SISPM1040-3248-L# traceroute ip 192.168.1.77 probes 3
traceroute to 192.168.1.77 (192.168.1.77), 30 hops max, 38 byte packets
 1 192.168.1.77 (192.168.1.77) 0.162 ms 0.136 ms 0.096 ms
```

Chapter 29 DHCP per Port

You can configure DHCP Per Port via the CLI and Web UI. The DHCP Per Port default mode is Disabled. See the *SISPM1040-3xxx-L Web User Guide* for web UI operation.

The switch's DHCP server assigns IP addresses. Clients get IP addresses in sequence and the switch assigns IP addresses to on a per-port basis starting from the configured IP range. For example, if the IP address range is configured as 192.168.10.20 - 192.168.10.37 with one DHCP device connected to port 1, the client will always get IP address 192.168.10.20, then port 3 is always distributed IP address 192.168.10.22, even if port 2 is an empty port (because port 2 is always distributed IP address 192.168.10.21).

The switch does not allow a DHCP per Port pool to include the switch's address.

IP address assigned range and VLAN 1 should stay in the same subnet mask.

The configurable IP address range is allowed to configure over 18 IP addresses, but the switch always assigns one IP address per port connecting device.

When the DHCP Per Port function is enabled, the switch software will automatically create the related DHCP pool named "DHCP_Per_Port".

Once the DHCP Per Port function is enabled on one switch, IPv4 DHCP client at VLAN1 mode (DMS DHCP mode), DHCP server mode are all limited to be enabled at the same time (an error message displays if attempted).

If the DHCP server pool has been configured, once you enable the DHCP Per port function that DHCP server pool configuration will be overwritten.

Only for VLAN 1, clients issued DHCP packets will not be broadcast/forwarded to other ports. DHCP packets in others VLANs will be broadcast/forwarded to others ports.

The DHCP Per Port function allows the switch to connect only one DHCP client device.

The DHCP Per Port function is configured and shown using these CLI commands:

```
SISPM1040-3248-L # show ip dhcp server
SISPM1040-3248-L (config)# ip dhcp server per-port
SISPM1040-3248-L (config)# no ip dhcp server per-port
SISPM1040-3248-L(config)# ip dhcp server per-port vlan
```

The CLI commands to configure and show DHCP Per Port are described below.

Command: Show the current DHCP Server and DHCP Per Port configuration

Syntax: **show ip dhcp server** <cr>

Description: Show if DHCP server is globally enabled or disabled, if all VLANs are disabled or enabled, and if the DHCP server Per Port function is disabled or enabled.

Example: Display the current DHCP Server and Per Port configuration, change the config, and display the results:

```
SISPM1040-3166-L(config)# do show ip dhcp server
```

```
DHCP server is globally enabled.  
Enabled VLANs are 1.  
DHCP server per port is disabled.
```

```
SISPM1040-3166-L(config)# ip dhcp server per-port  
SISPM1040-3166-L(config)# do show ip dhcp server
```

```
DHCP server is globally enabled.  
Enabled VLANs are 1.  
DHCP server per port is enabled.
```

```
SISPM1040-3166-L(config)# no ip dhcp server per-port  
SISPM1040-3166-L(config)# do show ip dhcp server
```

```
DHCP server is globally enabled.  
Enabled VLANs are 1.  
DHCP server per port is disabled.
```

```
SISPM1040-3166-L(config)#
```

Command: Configure the DHCP Per Port function

Syntax: **ip dhcp server per-port** <cr>

Description: Toggle the DHCP Per Port function from Disabled (default) to Enabled.

Example: Toggle the DHCP Per Port function and show the resulting config:

```
SISPM1040-3166-L(config)# ip dhcp server per-port  
SISPM1040-3166-L(config)# exit  
SISPM1040-3166-L# show ip dhcp relay  
Switch DHCP relay mode is enabled  
Switch DHCP relay server address is 0.0.0.0  
Switch DHCP relay information option is enabled  
Switch DHCP relay information policy is keep  
SISPM1040-3166-L#
```

Command: `ip dhcp server per-port vlan`

Description: Set DHCP per port VLAN (the VLAN associated with the IP interface). Only ports in this VLAN will be able to access the IP interface. This command is only available for input when creating a new interface. Added at FW v 8.50.0096.

Mode: Config mode

Syntax: `ip dhcp server per-port [vlan { <portPortVLAN> }]`

Parameters:

<code>per-port</code>	Enable DHCP server per port
<code>vlan</code>	DHCP server per port VLAN
<code><vlan_id></code>	Set DHCP server per port VLAN

Example:

```
SISPM1040-3166-L(config)# ip dhcp server per-port vlan 10
% Failed to create interface vlan 10
SISPM1040-3166-L(config)# ip dhcp server per-port vlan 1
SISPM1040-3166-L(config)# do show ip dhcp vlan 10
```

VLAN: 10

```
-----
Mode:          Disabled
Type:          Network
IP Range:      0.0.0.0 - 0.0.0.0
Lease Time:    86400
Subnet Mask:   0.0.0.0
Default Router: 0.0.0.0
DNS Server:    0.0.0.0
```

```
SISPM1040-3166-L(config)# do show ip dhcp vlan 1
```

VLAN: 1

```
-----
Mode:          Disabled
Type:          Network
IP Range:      0.0.0.0 - 0.0.0.0
Lease Time:    86400
Subnet Mask:   0.0.0.0
Default Router: 0.0.0.0
DNS Server:    0.0.0.0
-----
```

```
S SISPM1040-3166-L(config)#
```

Messages: *VLAN 100 is not configured.*

Appendix A – MRP Configuration

MRP Pre-Requisites and Application Examples

Media Redundancy Protocol (MRP) parameters can be configured via the Web UI at Configuration > MRP and monitored at Monitor > MRP, and via the CLI.

According to ANSI, [IEC 62439-2 Ed. 1.0 b:2010](#) is applicable to high-availability automation networks based on [ISO/IEC 8802-3 / IEEE 802.3 Ethernet technology](#). It specifies a recovery protocol based on a ring topology, designed to react deterministically on a single failure of an inter-switch link or switch in the network, under the control of a dedicated Media Redundancy Manager (MRM) node.

Media Redundancy Protocol per IEC 62439-2 is an interoperable ring technology designed to allow a switch to connect onto a universal redundant high speed ring. MRP is self-healing and self-adjusting, requiring no operator interaction. MRP is based on the concept of standby connections for seamless redundancy.

MRP Description

1. MRP operates at the MAC Layer of the Ethernet Switch.
2. The Ring Manager is called the Media Redundancy Manager (MRM). Only one MRM is supported.
3. Ring Clients are called Media Redundancy Clients (MRCs).
4. MRM and MRC ports support three Status Types:
 - a. *Disabled* ring ports drop all the received frames.
 - b. *Blocked* ring ports drop all the received frames except the MRP control frames.
 - c. *Forwarding* ring ports forward all the received frames.
5. Ring Reconfiguration speed is 200 ms for 50 switches on average.
6. The MRM continuously sends Watchdog Packets into the ring network to verify communication between ring points.
7. During normal operation, no packets are transmitted over the redundant link.
8. When the MRM no longer receives the Watchdog Packets it sent out, the redundant path is immediately activated, and it becomes the primary layer 2 packet path.
9. When the failed link is restored:
 - a. The MRM switches back to normal operation and the first Path becomes the primary path again.
 - b. You can configure a period of time before the MRM switches back to the primary path (to prevent the circuit from flapping if it is not stable).

MRP Operation

Normal operation: the network works in the *Ring-Closed* status. In this status, one of the MRM ring ports is blocked, while the other is forwarding. Conversely, both ring ports of all MRCs are forwarding. Loops are avoided because the physical ring topology is reduced to a logical stub topology.

Failure mode: the network works in the *Ring-Open* status. For instance, in case of failure of a link connecting two MRCs, both ring ports of the MRM are forwarding. The MRCs adjacent to the failure have a blocked and a forwarding ring port; the other MRCs have both ring ports forwarding. The physical ring topology is also a logical stub topology in the Ring-Open status.

MRP Sample Setup

The example below shows a setup with six switches (one MRM and five MRCs).

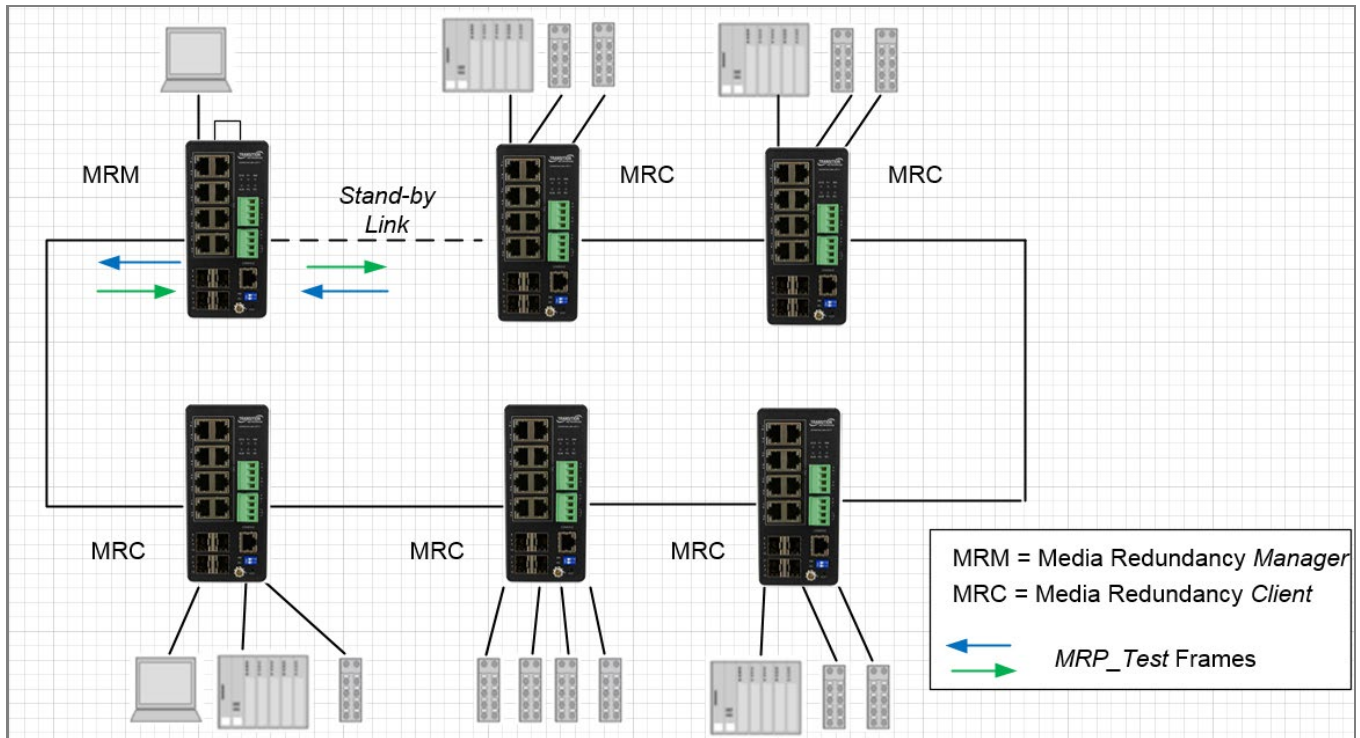

Figure: MRP Sample Setup

MRP Pre-Requisites (General)

The following steps are required to perform MRP setups.

1. Spanning Tree must be disabled at Configuration > Spanning Tree > CIST Port.
2. Other Ring technologies must be disabled (G.8031 EPS, G.8032 ERPS, Rapid-Ring, Ring-To-Ring, etc.).
3. Other pre-requisites may apply to the specific examples below.

MRP Configuration (CLI Commands)

Example 1: Create two new MRP domains on an SISPM1040-3248-L:

```
SISPM1040-3248-L(config)# mrp domain new 1
SISPM1040-3248-L(config)# mrp domain new 2
SISPM1040-3248-L(config)#
```

Example 2: Show default config for newly-created MRP domains 1 and 2:

```
SISPM1040-3248-L(config)# do show mrp 1
Domain:
  Admin Role:          Undefined
  Name:                Domain1
  UUID:                Default
  Primary Ring Port ID: Undefined
  Secondary Ring Port ID: Undefined
  VLAN ID:             0
SISPM1040-3248-L(config)# do show mrp 2
Domain:
  Admin Role:          Undefined
  Name:                Domain2
  UUID:                Default
  Primary Ring Port ID: Undefined
  Secondary Ring Port ID: Undefined
  VLAN ID:             0
SISPM1040-3248-L(config)#
```

Example 3: Configure MRP 1 (Manager) and MRP 2 (Client) parameters:

```
SISPM1040-3248-L(config)# mrp 1 role manager
SISPM1040-3248-L(config)# mrp 1 manager media-redundancy enable
SISPM1040-3248-L(config)# mrp 1 manager priority 3
SISPM1040-3248-L(config)# mrp 1 manager test-interval 25
SISPM1040-3248-L(config)# mrp 1 manager test-monitoring 4 2
SISPM1040-3248-L(config)# mrp 1 vlan 100
SISPM1040-3248-L(config)# mrp 2 client blocked-state enable
SISPM1040-3248-L(config)# mrp 2 client link-interval 15 30 2
SISPM1040-3248-L(config)# mrp 2 ringport secondary GigabitEthernet 1/5
SISPM1040-3248-L(config)# mrp 2 vlan 200
SISPM1040-3248-L(config)#
```

Example 4: Show newly-configured MRP 1 parameters:

```
SISPM1040-3248-L(config)# do show mrp 1
Operational:
  Role:                Undefined
  Status:              Disabled
  Ring State:          Undefined
  Primary Ring Port State: Unknown
  Secondary Ring Port State: Unknown
```

```

Domain:
  Admin Role:      Manager
  Name:            Domain1
  UUID:           Default
  Primary Ring Port ID:  Undefined
  Secondary Ring Port ID: Undefined
  VLAN ID:        100
Manager:
  Priority:          3
  Topology Change Interval, ms:  10
  Topology Change Repeat Count:  3
  Short Test Interval, ms:       10
  Default Test Interval, ms:     25
  Test Monitoring Count:         4
  Test Monitoring Extended Count: 2
  Non-blocking MRC supported:    Disabled
  React On Link Change:         Disabled
  Check Media Redundancy Event:  Enabled
SISPM1040-3248-L(config)#

```

Example 5: Show newly-configured MRP 2 parameters:

```

SISPM1040-3248-L(config)# do show mrp 2
Operational:
  Role:            Undefined
  Status:         Disabled
  Primary Ring Port State:  Unknown
  Secondary Ring Port State: Unknown
Domain:
  Admin Role:      Client
  Name:            Domain2
  UUID:           Default
  Primary Ring Port ID:  Undefined
  Secondary Ring Port ID:  5
  VLAN ID:        200
Client:
  Link Down Interval, ms:  15
  Link Up Interval, ms:   30
  Link Change Count:      2
  BLOCKED state supported: Enabled
SISPM1040-3248-L(config)#

```

Messages: *W mrp 247/mrp_ikli_domain_uuid#219: Warning: MRP Domain UUID: The UUID incorrect*

W mrp 247/mrp_ikli_domain_vlan#321: Warning: MRP Domain Vlan ID: unable to modify domain with Id 2, VLAN ID is used in other ring domain

**Lantronix Corporate Headquarters**

48 Discovery, Suite 250
Irvine, CA 92618, USA
Toll Free: 800-526-8766
Phone: 949-453-3990
Fax: 949-453-3995

Technical Support

Online: <https://www.lantronix.com/technical-support/>

Sales Offices

For a current list of our domestic and international sales offices, go to the Lantronix web site at www.lantronix.com/about/contact.