

# Print Servers

Wired/Wireless



**ZEBRA**

## User Guide

© 2017 ZIH Corp. The copyrights in this manual and the software and/or firmware in the label printer described therein are owned by ZIH Corp. Unauthorized reproduction of this manual or the software and/or firmware in the label printer may result in imprisonment of up to one year and fines of up to \$10,000 (17 U.S.C.506). Copyright violators may be subject to civil liability.

This product may contain ZPL<sup>®</sup>, ZPL II<sup>®</sup>, and ZebraLink<sup>™</sup> programs; Element Energy Equalizer<sup>®</sup> Circuit; E<sup>3</sup><sup>®</sup>; and Monotype Imaging fonts. Software © ZIH Corp. All rights reserved worldwide.

ZebraLink and all product names and numbers are trademarks, and Zebra, the Zebra logo, ZPL, ZPL II, Element Energy Equalizer Circuit, and E<sup>3</sup> Circuit are registered trademarks of ZIH Corp. All rights reserved worldwide.

All other brand names, product names, or trademarks belong to their respective holders. For additional trademark information, please see “Trademarks” on the product CD.

**Proprietary Statement** This manual contains proprietary information of Zebra Technologies Corporation and its subsidiaries (“Zebra Technologies”). It is intended solely for the information and use of parties operating and maintaining the equipment described herein. Such proprietary information may not be used, reproduced, or disclosed to any other parties for any other purpose without the express, written permission of Zebra Technologies Corporation.

**Product Improvements** Continuous improvement of products is a policy of Zebra Technologies Corporation. All specifications and designs are subject to change without notice.

**Liability Disclaimer** Zebra Technologies Corporation takes steps to ensure that its published Engineering specifications and manuals are correct; however, errors do occur. Zebra Technologies Corporation reserves the right to correct any such errors and disclaims liability resulting therefrom.

**Limitation of Liability** In no event shall Zebra Technologies Corporation or anyone else involved in the creation, production, or delivery of the accompanying product (including hardware and software) be liable for any damages whatsoever (including, without limitation, consequential damages including loss of business profits, business interruption, or loss of business information) arising out of the use of, the results of use of, or inability to use such product, even if Zebra Technologies Corporation has been advised of the possibility of such damages. Some jurisdictions do not allow the exclusion or limitation of incidental or consequential damages, so the above limitation or exclusion may not apply to you.

# Contents

- Introduction ..... 7**
  - Overview ..... 8
  - Support ..... 8
    - Browser Requirements ..... 8
    - Supported Services ..... 8
    - Address Administration Protocols ..... 8
    - Supported Wireless Radio Cards ..... 9
    - Supported Security Types ..... 10
  - Printer Requirements ..... 14
    - Hardware—Wired Print Servers ..... 14
    - Hardware—Wireless Print Servers ..... 15
    - Memory Requirements ..... 16
    - Firmware—10/100 Print Server ..... 17
    - Firmware—Wireless ..... 18
  - Compatibility ..... 19
  - Specifications ..... 19
    - External 10/100 Print Server Specifications ..... 19
    - Internal Print Server Specifications ..... 20
    - Wireless Print Server Specifications ..... 21
- Installation ..... 23**
  - External 10/100 Print Server ..... 24
    - Before You Begin ..... 24
    - Illustration ..... 25
    - Installation Instructions ..... 26
  - Internal 10/100 Print Server ..... 27
  - Wireless Print Servers ..... 27

Install a Radio Card in a Wireless Print Server .....	27
Wireless Radio Card .....	27
Compact Flash Wireless Radio Card .....	29
<b>Getting Started .....</b>	<b>31</b>
Before You Begin .....	33
Default User ID and Password .....	33
Printing a Configuration Label— External 10/100 Print Server .....	34
Printing a Network Configuration Label .....	36
Configuration of Wireless Securities .....	40
View Wireless Status through the Control Panel .....	41
LCD Link Status and Wireless Signal Indicators (Other Printers) .....	42
HC100 Wireless Status Indicator Lights .....	43
Network Status Indicator Lights .....	44
Determining the Active Print Server .....	45
Viewing IP Addresses and the Active Print Server .....	45
Active Device Selection .....	46
Assigning an IP Address on any Print Server .....	48
With Dynamic Host Configuration Protocol (DHCP) .....	48
Assigning an IP Address Without DHCP via ZebraNet Bridge .....	48
Assigning an IP address Without DHCP from the Control Panel .....	48
Assigning an IP Address Without DHCP via a Telnet Session .....	49
Setting and Monitoring Alerts on Any Print Server .....	51
Using ZebraNet Bridge .....	51
ZebraLink Alerts .....	51
Using WebView .....	53
Checking Print Server Configuration Settings .....	56
Using ZebraNet Bridge .....	56
Using WebView .....	56
Enabling Protocols .....	59
Using WebView .....	59
Defaulting ALL Print Servers .....	61
Using WebView .....	61
Using ZebraNet Bridge .....	63
Using a ZPL Command .....	63
Defaulting a 10/100 Print Server .....	63
Defaulting the Print Servers on the LP/TLP 2824 Plus and G-Series Printers	64
Defaulting the Print Servers on the HC100 Printers .....	64
Defaulting the Print Servers on the ZM400 and ZM600 Printers .....	64
Defaulting the Print Servers on 105SL, PAX4, Xi4, ZE500, and 105SLPlus	65
Printers .....	65
Defaulting the Print Servers on the ZD400, ZD500R, and ZTxxx Printers	65

<b>Printing Queues</b> .....	<b>67</b>
Berkeley Software Distribution (BSD)-Style Print Queue .....	68
Configuring the Print Queue .....	68
System V Queue Installation .....	69
Configuring Operating System V Queue for Printing .....	69
Prerequisites .....	69
UNIX Configuration .....	69
<b>Using Printing Protocols</b> .....	<b>71</b>
IPP .....	72
FTP .....	73
<b>ZebraLink WebView</b> .....	<b>75</b>
WebView .....	76
Home Page .....	76
View Printer Configuration .....	78
View and Modify Printer Settings .....	80
Network Communications Screens .....	86
Directory Listing .....	93
Printer Controls .....	97
<b>Print Server Web Pages</b> .....	<b>99</b>
Status and Configuration .....	100
Print Server Status .....	107
View Port Status .....	109
Reset .....	110
Restore .....	111
<b>Control Panel</b> .....	<b>113</b>
Control Panel Menu Options .....	114
Wired Network Parameters on the Printer Display .....	114
Wireless Network Parameters on the Printer Display .....	116
<b>Hardware Troubleshooting</b> .....	<b>119</b>
Troubleshooting the External 10/100 Print Server .....	120
Resetting to Factory Defaults .....	120
External 10/100 Print Server Network Status and Status Indicators . . .	120
Troubleshooting the External 10/100 Print Server .....	121
Troubleshooting the Internal Print Server .....	123
Resetting the Internal Print Server to Factory Defaults .....	123
Internal Print Server Network Status and Activity Indicators .....	123
Troubleshooting the Wireless Print Server .....	125
Print Server Will Not Operate on the 5Ghz Band .....	125
Resetting the Wireless Print Server to Factory Defaults .....	125

- ZebraNet Bridge Discovery or Configuration Problems .....126
- Unable to Print .....126
  - Ping the Printer .....127
  - Telnet .....127
- Unable to Configure Device .....128
- HP JetAdmin or HP Web JetAdmin .....128
- Wireless Error Messages .....128
- General Wireless Issues .....129
- Encryption and Authentication Issues .....131
- IP Issues .....132
- Frequently Asked Questions ..... 133**
  - FAQs .....133
- Glossary ..... 137**
- Index ..... 143**

# Introduction

This chapter provides a high-level overview of Zebra’s wired and wireless print servers, installation types, standard network configurations, and how to work with the print servers.

## Contents

Overview .....	8
Support. ....	8
Browser Requirements .....	8
Supported Services .....	8
Address Administration Protocols .....	8
Supported Wireless Radio Cards .....	9
Supported Security Types .....	10
Printer Requirements .....	14
Hardware—Wired Print Servers .....	14
Hardware—Wireless Print Servers .....	15
Memory Requirements .....	16
Firmware—10/100 Print Server .....	17
Firmware—Wireless .....	18
Compatibility .....	19
External 10/100 Print Server Specifications .....	19
External 10/100 Print Server Specifications .....	19
Internal Print Server Specifications .....	20
Wireless Print Server Specifications .....	21

## Overview

The print server is an optional factory- or field-installed device that connects the network and your ZebraLink-enabled printer. The print server provides you with a web browser as a user interface for printer and print server settings. If you use ZebraNet Bridge Enterprise, you can easily access the specialized features of a ZebraLink-enabled printer. For details, see the ZebraNet Bridge Enterprise User Guide.



**Note** • You can download the most recent version of ZebraNet Bridge Enterprise from [www.zebra.com/utilities](http://www.zebra.com/utilities).

## Support

This section lists the minimum requirements for print servers, which include browsers, supported services, address administration protocols, hardware, and firmware.

### Browser Requirements

- HTML v3.2 or higher
- Internet Explorer

### Supported Services

- |                |          |
|----------------|----------|
| • Raw TCP      | • FTP    |
| • HTTP         | • UDP    |
| • LPR/LPD      | • Telnet |
| • SNMPv1       | • SMTP   |
| • POP3         | • WINS   |
| • IPP v1.0 * † | • ARP    |

\* Supported only on the external 10/100 Print Server.

† Supported only on the internal 10/100 Print Server for *PAX4* and *105SL* printers/print engines.

### Address Administration Protocols

- DHCP
- BootP
- RARP
- Gleaning
- Permanent





## Supported Wireless Radio Cards



**Note** • This section applies only to the Wireless Print Server and the Wireless Plus Print Server. All other wireless print servers supported by this manual have a built-in radio.

A supported third-party PCMCIA, Compact Flash™, or CardBus wireless radio card is required for the printer to connect to the WLAN. After the wireless option board is installed in the printer, the wireless radio card inserts into a slot on this board. A wireless radio card is NOT provided with the Wireless Print Server or the Wireless Plus Print Server.



**Note** •

- Some wireless radio cards listed here may not support all wireless print server features.
- See [Table 1 on page 11](#) or check with the card manufacturer to ensure that the card that you wish to use supports the wireless security type used on your WLAN.
- Some wireless radio cards may require specific firmware versions to support certain features. You may be able to download new firmware to your wireless radio card. Check with the card manufacturer for more information.
- Check the operating conditions (such as temperature and humidity) for the wireless radio card that you choose. If the card has more restrictions than the printer, this may limit the conditions under which you can operate the printer with a wireless connection.

The following wireless radio cards are supported at the time of this release:

### Symbol® Technologies

- Spectrum24® Compact Flash wireless radio card LA-4137-1020-WW (the card uses an adapter and must have firmware version F3.91-69 or later)  
For instructions on how to install this card and the adapter, see *Install a Radio Card in a Wireless Print Server* on page 27.
- 802.11b Spectrum24 High Rate Direct Sequence PN:LA-4121-1000-US (card must have firmware version V2.90-58 or later)
- 802.11b Spectrum24 High Rate Direct Sequence PN:LA-4121-1020-US (card must have firmware version V2.90-58 or later)
- 802.11b Spectrum24 High Rate Direct Sequence PN:LA-4121-1120-US (card must have firmware version V2.90-58 or later)

## Cisco® Systems

All Aironet® cards must have card firmware version 5.60.21 or later.

- 802.11g Aironet CB21AG CardBus wireless radio card (for the Wireless Plus Print Server only)
- 802.11b Aironet AIR-PCMC340
- 802.11b Aironet AIR-PCMC341
- 802.11b Aironet AIR-PCMC342
- 802.11b Aironet PCMC350
- 802.11b Aironet PCMC351
- 802.11b Aironet PCMC352

## Supported Security Types

Your WLAN can use any of a number of different types of security and encryption, or it can use none at all. This section shows which security types you can use with the various wireless print servers.



**Note** • Configuring a printer for WPA also allows the printer to be used in WPA2 environments.

## Wireless Plus Print Server

Table 1 lists the security types that are supported by the Wireless Plus Print Server. Support varies by the card manufacturer and the card type. Select a wireless radio card that is supported by your wireless print server and that supports the security type being used on your WLAN.

**Table 1 • Security Types Supported on the Wireless Plus Print Server**

Security Type	Card Manufacturer			
	Cisco		Symbol	
	Cisco CB21	Cisco 350	LA-4121 (PCMCIA)	LA-4137 Compact Flash
Open	Yes	Yes	Yes	Yes
EAP-FAST	Yes	Not Supported	Yes	Yes
EAP-TLS	Yes	Not Supported	Not Supported	Yes
EAP-TTLS	Yes	Not Supported	Not Supported	Yes
Kerberos	Not Supported	Not Supported	Yes	Yes
LEAP	Yes	Yes	Yes	Yes
PEAP	Yes	Not Supported	Yes	Yes
WEP (40 bit and 128 bit)	Yes	Yes	Yes	Yes
WPA - LEAP	Yes	Yes	Yes	Yes
WPA - PSK	Yes	Yes	Yes	Yes
WPA- EAP-FAST	Yes	Yes	Yes	Yes
WPA- EAP-TLS	Yes	Yes	Yes	Yes
WPA- EAP-TTLS	Yes	Yes	Yes	Yes
WPA- PEAP	Yes	Yes	Yes	Yes
WPA2 - LEAP	Yes	Not Supported	Not Supported	Not Supported
WPA2 - PSK*	Yes*	Not Supported	Not Supported	Not Supported
WPA2- EAP-FAST	Yes	Not Supported	Not Supported	Not Supported
WPA2- EAP-TLS	Yes	Not Supported	Not Supported	Not Supported
WPA2- EAP-TTLS	Yes	Not Supported	Not Supported	Not Supported
WPA2- PEAP	Yes	Not Supported	Not Supported	Not Supported

\* Key rotation for WPA2 PSK is supported in firmware version V60.15.8Z or later, V53.15.8Z or later., and RX.15.8Z or later.

## Internal Wireless Plus Print Server and Other a/b/g/n/ac Print Servers

Table 2 lists the security types that are supported by the Internal Wireless Plus Print Server and other print servers that include a/b/g/n/ac.

**Table 2 • Security Types Supported on the Internal Wireless Plus Print Server and all a/b/g/n/ac Print Servers**

Security Type	Supported?
Open	Yes
EAP-FAST	Yes
EAP-PEAPv2	Yes *
EAP-TLS	Yes
EAP-TTLS	Yes
Kerberos	Not Supported
Key Management	Yes *
LEAP	Yes
MIC	Yes *
PEAP	Yes
WEP (40 bit and 128 bit)	Yes
WPA - LEAP	Yes
WPA - PSK	Yes
WPA - EAP-FAST	Yes
WPA - EAP-TLS	Yes
WPA - EAP-TTLS	Yes
WPA - PEAP	Yes
WPA - TKIP	Yes *
WPA2 - 802.1x + AES	Yes *
WPA2 - LEAP	Yes
WPA2 - PSK	Yes
WPA2 - EAP-FAST	Yes
WPA2 - EAP-TLS	Yes
WPA2 - EAP-TTLS	Yes
WPA2 - PEAP	Yes

\*Note: Supported on the n Print Server only

## Wireless Print Server

Table 3 lists the security types that are supported by the Wireless Print Server. Support varies by the card manufacturer and the card type. Select a wireless radio card that is supported by your wireless print server and that supports the security type being used on your WLAN. The Wireless Print Server does not support the Cisco CB21 radio card.

**Table 3 • Security Types Supported on the Wireless Print Server**

Security Type	Card Manufacturer		
	Cisco	Symbol	
	Cisco 350	LA-4121 (PCMCIA)	LA-4137 Compact Flash
Open	Yes	Yes	Yes
EAP-FAST	Not Supported	Not Supported	Yes
EAP-TLS	Not Supported	Not Supported	Yes
EAP-TTLS	Not Supported	Yes	Yes
Kerberos	Not Supported	Yes	Yes
LEAP	Yes	Yes	Yes
PEAP	Not Supported	Yes	Yes
WEP (40 bit and 128 bit)	Yes	Yes	Yes
WPA - LEAP	Yes	Yes	Yes
WPA - PSK	Yes	Yes	Yes
WPA- EAP-FAST	Yes	Yes	Yes
WPA- EAP-TLS	Yes	Yes	Yes
WPA- EAP-TTLS	Yes	Yes	Yes
WPA- PEAP	Yes	Yes	Yes

## Printer Requirements



### Hardware—Wired Print Servers



Table 4 indicates which printers are compatible with wired print server options.

**Table 4 • Wired Print Servers Available by Printer**

Printers	External *	Internal Field Upgrade	Internal Factory
105SL	X	X	X
105SLPlus	X	X	X
GK420	X	—	X
GX420/GX430	X	—	X
HC100	—	—	X
LP/TLP 2824 Plus	—	—	X
PAX4 series	X	X	X
R110PAX4	X	X	X
R110Xi4	X	X	X
RZ400	X	X	X
RZ600	X	X	X
Xi4	X	X	X
ZD400 Series	—	—	X
ZD500R	X		X
ZE500	X	X	X
ZM400	X	X	X
ZM600	X	X	X
ZT200 Series	X	X	X
ZT400 Series	X	—	X
ZT510	X	—	X
ZT600 Series	X	—	X

\* For additional information on print server firmware versions, see [Firmware—10/100 Print Server](#) on page 17.



## Hardware—Wireless Print Servers

Table 5 indicates which printers are compatible with wireless print server options.

**Table 5 • Wireless Print Servers Available by Printer**

Printers	a/b/g/n/ac	a/b/g/n	b/g	Internal Wireless Plus	Wireless Plus	Wireless
105SL	—	—	—	X	X	X
105SLPlus	—	—	X	—	—	—
GK420	—	—	X	—	—	—
GX420/430	—	—	X	—	—	—
HC100	—	—	X	—	—	—
LP/TLP 2824 Plus	—	—	—	—	—	—
PAX4 series	—	—	X	X	X	X
R110PAX4	—	—	—	X	X	X
R110Xi4	—	—	X	X	X	X
RZ400	—	—	X	X	X	X
RZ600	—	—	X	X	X	X
Xi4	—	—	X	X	X	
ZD400 Series	X	—	—	—	—	—
ZD500R	—	X	—	—	—	—
ZE500	—	—	X	—	—	—
ZM400	—	—	X	X	X	—
ZM600	—	—	X	X	X	—
ZT200 Series	—	X	—	—	—	—
ZT400 Series	—	X	—	—	—	—
ZT510	X	—	—	—	—	—
ZT600 Series	X	—	—	—	—	—

## Memory Requirements

**PCMCIA and Compact Flash Memory Cards** PCMCIA memory or Compact Flash memory cards will not work and are not supported on the Wireless Plus Print Server. The Internal Wireless Plus Print Server and the a/b/g/n/ac Print Servers do not include a slot for these card types.

**Wireless Card Socket Option** The wireless print server options replace the Wireless Card Socket Option (WCSO) in 105SL printers with a serial number of 6400357 or greater. Do not install a wireless option board on a 105SL printer with a serial number that is less than 6400357.

**Wireless Option Board** A special wireless option board must be installed in your printer/print engine. To determine if you have a wireless option board installed, use a printer configuration label (refer to the printing instructions in your printer User Guide). To purchase a wireless option, contact your authorized Zebra reseller for more information.

The wireless option boards are identified by the **HARDWARE ID** line on the printer configuration label.

```

+10..... LCD ADJUST
DPSWFXM..... MODES ENABLED
..... MODES DISABLED
832 8/MM FULL..... RESOLUTION
V50 15 17<-..... FIRMWARE
V23 29882-001_3..... HARDWARE ID
CUSTOMIZED..... CONFIGURATION
3264k.....R: RAM
61440k.....E: ONBOARD FLASH
NONE..... FORMAT CONVERT
FW VERSION..... IDLE DISPLAY
    
```

The part numbers shown on the **HARDWARE ID** line indicate the wireless print servers as shown in [Table 6](#).

**Table 6 • Zebra Part Numbers for Wireless Print Server Boards**

Part Number	Corresponds to the Following	Radio Included?
P1033782-0xx	n Print Server	Yes
P1033557-0xx	b/g Print Server	Yes
P1033605-001		
PCBA P1033782-03x	a/b/g/n Print Server	Yes
PCBA P1077918-01x	a/b/g/n/ac Print Server	Yes
29652-0xx	Internal Wireless Plus Print Server	Yes
29883-001		
29651-0xx	Wireless Plus Print Server	No. Requires a third-party radio card.
29882-001		
29881-009	Wireless Print Server	No. Requires a third-party radio card.
79077		
79078		
79079		
79100		





## Firmware—10/100 Print Server

All external print servers are available with several versions of print server firmware. *PAX4* and *105SL* printers use print server firmware version 1.01.x.

To determine the proper firmware version, first determine your hardware version.

**To locate your hardware version, perform the following:**

1. Which type of printer and print server do you have?

If you have...	Then...
A printer with an external print server	<ol style="list-style-type: none"> <li>Look at the side of the print server.</li> <li>See <a href="#">Figure 1</a>. Your hardware version is listed on the Compliance label.</li> <li>Your hardware version number is either blank or V2.                             <ul style="list-style-type: none"> <li>If your hardware version is blank, assume this means V1 (version 1). You will need firmware version 1.01.x.</li> <li>If your hardware version is V2, you will need firmware version 2.01.x.</li> </ul> </li> </ol>
A printer with an internal print server	<ol style="list-style-type: none"> <li>Your hardware version will be V1.</li> <li>You will need firmware version 1.01.x.</li> </ol>

**Figure 1 • External 10/100 Print Server Sample Compliance Label**

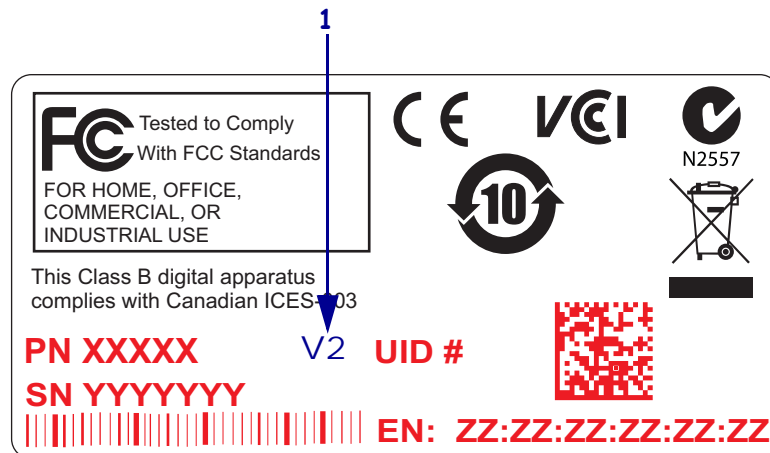

<b>1</b>	Location of hardware version
----------	------------------------------



## Firmware—Wireless

After a wireless option board is installed, your printer must be running a supported firmware version to access the features in this manual. [Table 7](#) shows the minimum firmware version required.

You may download the latest firmware appropriate for your printer to access the latest encryption features. Go to <http://www.zebra.com/firmware> for firmware download options.

**Table 7 • Supported Firmware Versions**

Printer	a/b/g/n/ac	Internal a/b/g/n	Internal b/g	Internal Wireless Plus	Wireless Plus	Wireless
105SL	—	—	—	V60.16.X	V60.15.X	V60.15.X
105SL <i>Plus</i>	—	—	V53.17.16Z	—	—	—
HC100	—	—	—	V54.16.X	—	—
110PAX4 170PAX4	—	—	V60.17.11Z	V60.16.X	V60.15.X	V60.15.X
R110PAX4	—	—	—	R62.16.X R63.16.X	R62.15.X R63.15.X	R62.15.X R63.15.X
R110Xi4	—	—	V53.17.11Z	V.53.17.7	V.53.17.7	—
RZ400 RZ600	—	—	V53.17.11Z	R53.16.X	R53.16.X	R53.16.X
Xi4	—	—	V53.17.11Z	V53.17.X	V53.17.X	—
ZD400 Series	P77.19.14Z	—	—	—	—	—
ZD500	—	V74.19.6Z	—	—	—	—
ZM400 ZM600	—	—	V53.17.11Z	V53.16.X	V53.15.X	—
ZE500	—	—	V53.17.15Z	—	—	—
ZT200 Series	—	V72.18.X	—	—	—	—
ZT400 Series	—	V75.19.7Z	—	—	—	—
ZT510	V80.20.4Z	—	—	—	—	—
ZT600 Series	V80.20.4Z	—	—	—	—	—

## Compatibility

This section identifies the various components that are compatible with all print servers.

**Software** IBM®: Tivoli® v7.1.3, HP®: Web JetAdmin™ v7.0, OpenView™ v6.4, and any SNMP management application via Zebra Management Information Base (MIB) all work with both the wired and wireless print servers.

## Specifications



### External 10/100 Print Server Specifications

General Specifications			
Network Connection		Ethernet 10BASE-T and 100BASE-T UTP RJ-45 connection Half and Full Duplex Communications	
Printer Connection		Bi-directional, IEEE-1284 Centronics parallel port (Compatibility, Nibble, and ECP)	
User Interface		LED activity indicators: <ul style="list-style-type: none"> <li>• bi-color display of operational status</li> <li>• bi-color display of speed and network activity</li> </ul>	
Height (external dimensions)		1.2 in.	30.48 mm
Width (external dimensions)		2.8 in.	71.12 mm
Length (external dimensions)		3.2 in.	81.28 mm
Weight		2.7 oz	77 g
Electrical		Maximum 450mA at 5.25VDC Power provided by the printer (Centronics pin 18, 5VDC at 450mA)	
Temperature	Operating	32° to 104°F	0° to 40°C
	Storage	-40° to 140°F	-40° to 60°C
Relative Humidity	Operating	20% to 85%, non-condensing	
	Storage	5% to 85%, non-condensing	
Agency Approvals		Agency Approvals <ul style="list-style-type: none"> <li>• IEC 60950</li> <li>• EN 55032, class B</li> <li>• EN 55024</li> </ul> Agency Marks <ul style="list-style-type: none"> <li>• FCC - B</li> <li>• ICES-003</li> <li>• VCCI</li> <li>• RCM</li> </ul>	



## Internal Print Server Specifications

<b>General Specifications</b>			
Network Connection		Ethernet 10BaseT and 100BaseT UTP RJ-45 connection Half and Full Duplex Communications	
User Interface		A single (two element) LED activity indicator: <ul style="list-style-type: none"> <li>• bi-color display of operational status (solid green or solid amber)</li> <li>• bi-color display of speed and network activity (flashing green or flashing amber)</li> </ul>	
Temperature	Operating	32° to 140°F	0° to 60°C
	Storage	-40° to 140°F	-40° to 60°C
Relative Humidity	Operating	20% to 80%, non-condensing	
	Storage	5% to 85%, non-condensing	



## Wireless Print Server Specifications

### General Specifications

Network Connection		<ul style="list-style-type: none"> <li>• IEEE 802.11b/g, 802.11a/b/g/n, 802.11a/b/g/n/ac</li> <li>• Data Rates up to 300 Mb per second</li> <li>• Wireless Medium DSSS and OFDM</li> <li>• Frequency Band: 2.4G or 2.4G/5G</li> </ul>	
User Interface		<ul style="list-style-type: none"> <li>• Link Status Indicator—real-time display of network status</li> <li>• Wireless Signal Indicators</li> </ul>	
Electrical		Power provided by the printer	
Temperature	Operating	32° to 140°F	0° to 60°C
	Storage	–40° to 140°F	–40° to 60°C
Relative Humidity	Operating	20% to 80%, non-condensing	
	Storage	5% to 85%, non-condensing	



**Notes •** \_\_\_\_\_

\_\_\_\_\_

\_\_\_\_\_

\_\_\_\_\_

\_\_\_\_\_

\_\_\_\_\_

\_\_\_\_\_

\_\_\_\_\_

\_\_\_\_\_

\_\_\_\_\_

\_\_\_\_\_

## Installation

This chapter provides information on how to install the Zebra's wired and wireless print servers.

### Contents

External 10/100 Print Server . . . . .	24
Before You Begin . . . . .	24
Illustration. . . . .	25
Installation Instructions . . . . .	26
Internal 10/100 Print Server . . . . .	27
Wireless Print Servers . . . . .	27
Install a Radio Card in a Wireless Print Server . . . . .	27
Wireless Radio Card . . . . .	27
Compact Flash Wireless Radio Card. . . . .	29



## External 10/100 Print Server

This section provides you with an illustration of the external 10/100 Print Server and the steps required for its installation. For a list of compatible printers, see [Hardware—Wired Print Servers on page 14](#).

### Before You Begin



**Important** • In order to take advantage of all features described in this manual, you must download firmware X.14 or later.



**Note** • Not all printers support firmware X.14 or later. On those printers, the features for this print server will be limited.

#### To upgrade you printer firmware, complete these steps:

1. If your printer has firmware x.12 firmware, you **must** upgrade your printer firmware to version x.14.x or higher.
2. To upgrade your firmware, visit the Zebra Web site, and download the latest firmware for your printer:  
[www.zebra.com/firmware](http://www.zebra.com/firmware)
3. Confirm that the upgrade was successful:

If...	Then...
Your printer has an LCD	Look at the lower right-hand corner and confirm the version of firmware that is on your printer.
Your printer does not have an LCD	Print out a configuration label to see the version of firmware that is on your printer.



## Illustration

Figure 2 shows an external 10/100 Print Server. When necessary, refer back to this illustration during the installation steps.

Figure 2 • External 10/100 Print Server

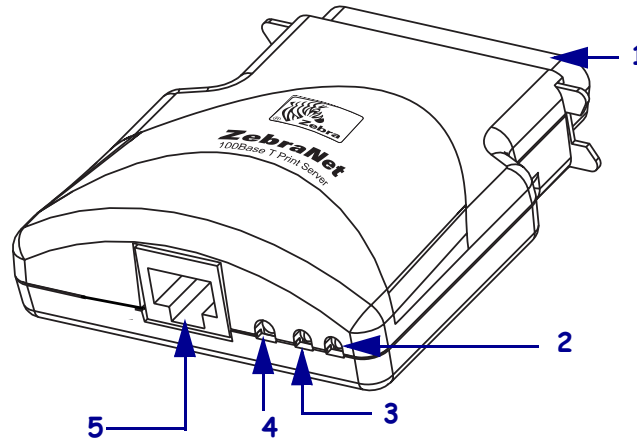

1	Parallel connector
2	Network status LED
3	Status LED
4	Test button
5	Ethernet connector

For more details on status indicators, see [External 10/100 Print Server Network Status and Status Indicators](#) on page 120.

## Installation Instructions

To install an external 10/100 Print Server, complete these steps:

1. Turn off (O) the printer.
2. On the back of the printer, connect the external 10/100 Print Server device to the parallel port.

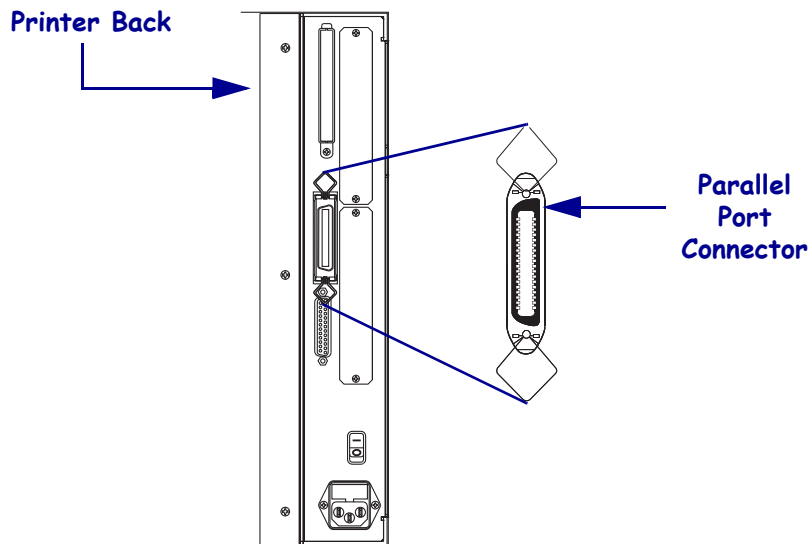

3. Secure the wire locks.
4. On the back of the external 10/100 Print Server, connect an active Ethernet cable to the RJ-45 connector Ethernet connector.
5. Turn on (I) the printer.  
The external 10/100 Print Server performs a Power On Self-Test (POST). This takes about 45 seconds. During the POST, the external 10/100 Print Server Status LED (just below the TEST button) turns red and flashes on and off. Once the POST is successfully completed and the external 10/100 Print Server is fully initialized, the Status LED turns green.

For more details on status indicators, see [External 10/100 Print Server Network Status and Status Indicators](#) on page 120.



**Note** • If there is not an active Ethernet cable attached to the external 10/100 Print Server, the Status LED turns red and slowly flashes on and off.

6. To check the status of the external 10/100 Print Server, press the Test button located on the back of the external 10/100 Print Server.

This prints out a configuration label of the external 10/100 Print Server. To see a sample label, see [Figure 4](#) on page 35.



## Internal 10/100 Print Server

To install an internal 10/100 print server, see the installation instructions that came with the print server.



## Wireless Print Servers

To install a wireless print server, see the installation instructions that came with the print server.



## Install a Radio Card in a Wireless Print Server



**Note** • This section applies only to the Wireless Print Server and the Wireless Plus Print Server. All other wireless print servers covered by this manual have a built-in radio.

Printers that have the wireless option board installed can use any of the wireless radio cards or Compact Flash wireless radio cards listed in [Supported Wireless Radio Cards on page 9](#). This section provides instructions for installing either type of card. Most printers use a clear plastic RF cover over the wireless radio card or compact Flash wireless radio card.

## Wireless Radio Card

This section applies to PCMCIA or CardBus wireless radio cards.



**Note** • Z4Mplus, R4Mplus, and Z6Mplus printers do not support CardBus wireless radio cards.

### To install a wireless radio card, complete these steps:

1. Turn off (O) the printer.
2. Remove and discard the metal cover that was shipped in place over the wireless option card slot on the back of the printer.

- Position the notch on the wireless radio card on the top, leading edge. Insert the wireless radio card into the wireless option card slot on the back of the printer until the card-eject button pops out.

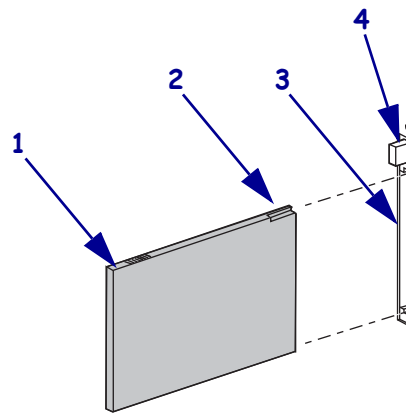

1	Wireless radio card
2	Notch
3	Wireless option card slot on back of printer
4	Card-eject button

- Place the RF card cover over the wireless radio card, and secure it with a small screw.

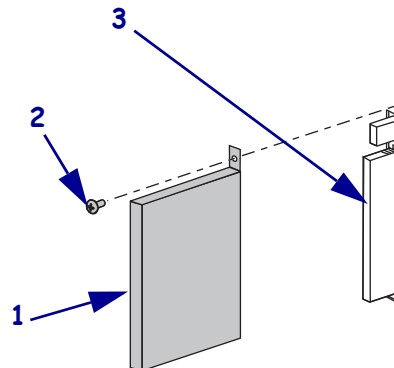

1	Clear plastic RF card cover (not used on all printers)
2	Screw
3	Wireless radio card

- Turn on (I) the printer.

The printer restarts and uses the wireless radio card to communicate with your WLAN. Allow several minutes for the printer to connect to the network. For more information about wireless status, refer to [View Wireless Status through the Control Panel on page 41](#) or [Troubleshooting the Wireless Print Server on page 125](#).

## Compact Flash Wireless Radio Card

This section applies to Compact Flash wireless radio cards, which require an adapter before they can be used in the wireless option card slot.

### To install a Compact Flash wireless radio card and adapter, complete these steps:

1. If you have not already done so, turn off (O) the printer.
2. Remove and discard the metal cover that was shipped in place over the wireless option slot on the back of the printer.
3. See [Figure 3](#). Position the adapter with the back facing as shown. Insert the adapter into the wireless option card slot on the back of the printer until the card-eject button pops out.
4. See [Figure 3](#). Insert the Compact Flash wireless radio card into the adapter.

**Figure 3 • Installing a Compact Flash Wireless Radio Card**

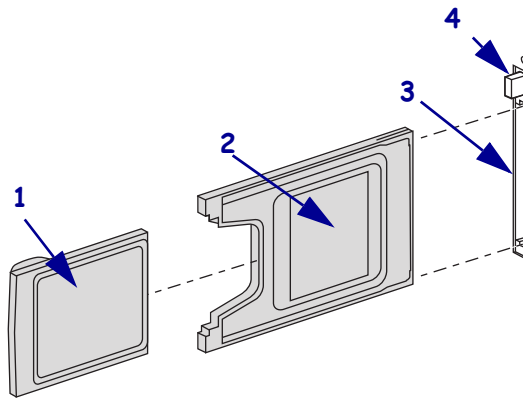

<b>1</b>	Back of Compact Flash wireless radio card
<b>2</b>	Back of adapter
<b>3</b>	Wireless option card slot on back of printer
<b>4</b>	Card-eject button

## 30 | Installation

### Install a Radio Card in a Wireless Print Server

5. Place the RF card cover over the wireless radio card, and secure it with a small screw.

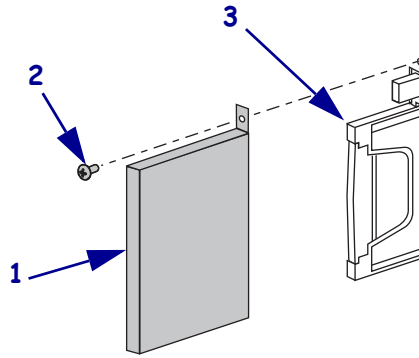

<b>1</b>	Clear plastic RF card cover (not used on all printers)
<b>2</b>	Screw
<b>3</b>	Compact Flash wireless radio card and adapter

6. Turn on (I) the printer.

The printer restarts and uses the wireless radio card to communicate with your WLAN. Allow several minutes for the printer to connect to the network. For more information about wireless status, refer to [View Wireless Status through the Control Panel on page 41](#) or [Troubleshooting the Wireless Print Server on page 125](#).

# Getting Started

This chapter provides you with information and procedures for working with the most frequently used print server features.

## Contents

Before You Begin . . . . .	33
Default User ID and Password. . . . .	33
Printing a Configuration Label— External 10/100 Print Server . . . . .	34
Printing a Network Configuration Label . . . . .	36
Configuration of Wireless Securities . . . . .	40
View Wireless Status through the Control Panel . . . . .	41
LCD Link Status and Wireless Signal Indicators (Other Printers) . . . . .	42
HC100 Wireless Status Indicator Lights . . . . .	43
Network Status Indicator Lights . . . . .	44
Determining the Active Print Server . . . . .	45
Viewing IP Addresses and the Active Print Server. . . . .	45
Active Device Selection . . . . .	46
Assigning an IP Address on any Print Server . . . . .	48
With Dynamic Host Configuration Protocol (DHCP) . . . . .	48
Assigning an IP Address Without DHCP via ZebraNet Bridge. . . . .	48
Assigning an IP address Without DHCP from the Control Panel. . . . .	48
Assigning an IP Address Without DHCP via a Telnet Session. . . . .	49
Setting and Monitoring Alerts on Any Print Server . . . . .	51
ZebraLink Alerts . . . . .	51
Using ZebraNet Bridge . . . . .	51
Using WebView . . . . .	53

- Checking Print Server Configuration Settings ..... 56
  - Using ZebraNet Bridge ..... 56
  - Using WebView ..... 56
- Enabling Protocols ..... 59
  - Using WebView ..... 59
- Defaulting ALL Print Servers ..... 61
  - Using WebView ..... 61
  - Using ZebraNet Bridge ..... 63
  - Defaulting a 10/100 Print Server ..... 63
  - Defaulting the Print Servers on the ZM400 and ZM600 Printers ..... 64
  - Defaulting the Print Servers on the LP/TLP 2824 Plus and G-Series Printers. .... 64
  - Defaulting the Print Servers on the HC100 Printers ..... 64
  - Defaulting the Print Servers on 105SL, PAX4, Xi4, ZE500, and 105SLPlus Printers . 65
  - Defaulting the Print Servers on the ZD400, ZD500R, and ZTxxx Printers. .... 65



## Before You Begin

Zebra's wired and wireless print servers offers many features, but how you access and work with them is dependent on your environment.

### Default User ID and Password

Throughout the procedures in this document, there are some features that require the default User ID and/or default password. If you are prompted, these are the defaults:

- **User ID:** admin
- **Password:** 1234



## Printing a Configuration Label— External 10/100 Print Server

To print the external 10/100 Print Server configuration label, the printer must be loaded with a label that is wide enough for the image ([Table 8](#)).

**Table 8 • Minimum Label Width**

DPI	Inches	mm
600	1.63	41.28
300	1.63	41.28
211	2.5	63.5
150	5.0	127.00

**To print an external 10/100 Print Server configuration label, complete these steps:**

1. Turn on (I) the printer and let it complete its power-up cycle.
2. When the POST cycle is complete, press the Test button and hold it in for a few seconds before you release it.

An external 10/100 Print Server configuration label prints. Your configuration label looks similar to [Figure 4 on page 35](#).

**Figure 4 • Configuration Label for an External 10/100 Print Server**

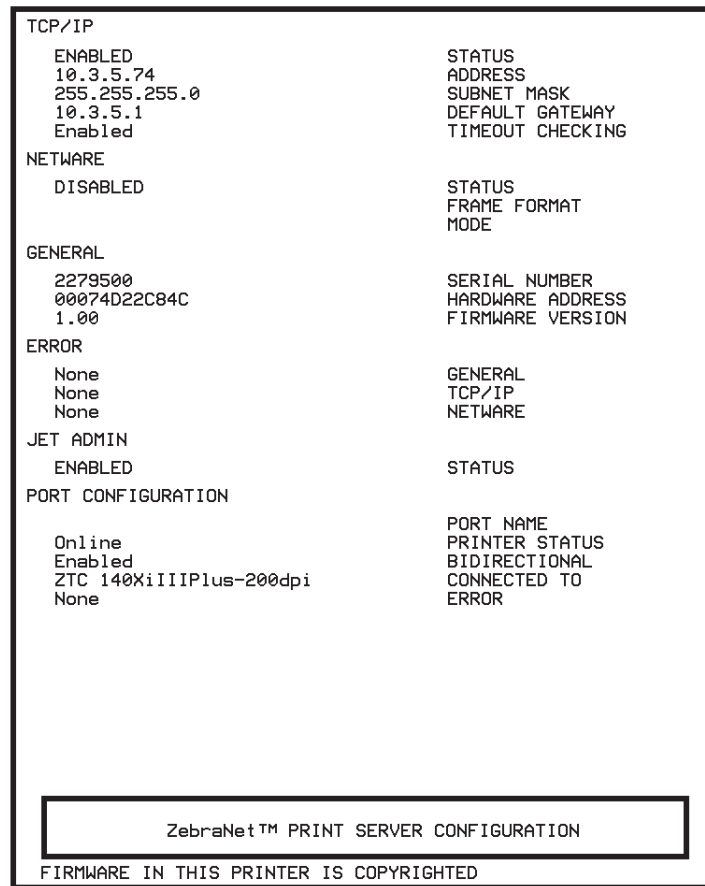

3. From the configuration label, you need to look for these numbers:
  - ADDRESS (IP address)
  - SUBNET MASK
  - DEFAULT GATEWAY
  - SERIAL NUMBER
  - HARDWARE ADDRESS (MAC address)
4. On the configuration label that prints out for your external 10/100 Print Server device, circle the aforementioned settings. You can now proceed to [Assigning an IP Address on any Print Server on page 48](#).



## Printing a Network Configuration Label

Table 9 shows the minimum label widths needed to print a network configuration label with different DPI printheads.

**Table 9 • Minimum Label Width**

DPI	Inches	MM
600	1.25	31.75
300	2.50	63.50
200	3.69	93.73

### To print the network settings for your printer, complete these steps:

1. Which printer do you have?

If you have a...	Then...
ZTxxx or ZD500R	Use the PRINT INFORMATION > NETWORK option to print a network configuration label (Figure 5 on page 38). You can access this menu item from the TOOLS menu or the NETWORK menu. Refer to the User Guide for your printer for specific instructions on how to use the control panel.
ZM400 or ZM600	<ol style="list-style-type: none"> <li>Press SETUP/EXIT to enter the Setup Mode.</li> <li>Scroll through the parameters by pressing PLUS (+) until you reach <b>LIST NETWORK</b>.</li> <li>Press SELECT.</li> <li>Press PLUS (+) to print a network configuration label (Figure 5 on page 38).</li> <li>Press SETUP/EXIT twice to exit the Setup Mode.</li> </ol>
G-Series or LP/TLP 2824 Plus	<ol style="list-style-type: none"> <li>Turn on (I) the printer and let it complete its power-up cycle.</li> <li>Press and hold FEED until you see one flash of the LED.</li> <li>After the LED flashes, release the button. Printer and a network configuration labels (Figure 6 on page 39) print.</li> </ol>
ZD400 Series	<ol style="list-style-type: none"> <li>Turn on (I) the printer and let it complete its power-up cycle.</li> <li>Press and hold FEED and CANCEL for 2 seconds.</li> <li>After 2 seconds, release the buttons. Printer and a network configuration labels (Figure 6 on page 39) print.</li> </ol>
HC100	<p> <b>Note</b> • The HC100 does not have a network configuration label. However, the IP Address, MAC Address, and other useful information appear on the printer configuration wristband.</p> <ol style="list-style-type: none"> <li>Turn on (I) the printer and let it complete its power-up cycle.</li> <li>Press and hold PAUSE/FEED until the green lights turn off on the printer status indicator and the orange lights blink once.</li> <li>Release PAUSE/FEED to print a printer configuration wristband (Figure 7 on page 39).</li> </ol>

If you have a...	Then...
Xi4, PAX4, 105SL, ZE500, or 105SLPlus	<ol style="list-style-type: none"> <li>a. Press SETUP/EXIT to enter the Setup Mode.</li> <li>b. Scroll through the parameters by pressing NEXT/SAVE (▶) until you reach <b>LIST NETWORK</b>.</li> <li>c. Press PLUS (+) to print a network configuration label (<a href="#">Figure 5 on page 38</a>).</li> <li>d. Press SETUP/EXIT to exit the Setup Mode.</li> <li>e. Press NEXT/SAVE to permanently save your changes.</li> </ol>

2. From the configuration label, look for these numbers:
  - IP PROTOCOL \*
  - IP ADDRESS
  - SUBNET MASK \*
  - DEFAULT GATEWAY \*
  - MAC ADDRESS

\* **Not available on HC100**
  
3. On the network configuration label, circle the aforementioned settings. You can now proceed to [Assigning an IP Address on any Print Server on page 48](#).

Figure 5 • Sample Network Configuration Labels

Only the sections applicable to your printer are printed on the network configuration label.

Network Configuration	
Zebra Technologies ZTC ZM400-200dpi ZPL ZBR2834777	
1.36.1733	OPTION FIRMWARE
Wired.....	PRIMARY NETWORK
NO.....	LOAD FROM EXT?
Internal Wired.....	ACTIVE PRINTSRVR
<b>External Wired</b>	
ALL.....	IP PROTOCOL
000.000.000.000.....	IP ADDRESS
255.255.255.000.....	SUBNET MASK
000.000.000.000.....	DEFAULT GATEWAY
000.000.000.000.....	WINS SERVER IP
YES.....	TIMEOUT CHECKING
300.....	TIMEOUT VALUE
000.....	ARP INTERVAL
9100.....	BASE RAW PORT
<b>Internal Wired*</b>	
ALL.....	IP PROTOCOL
010.003.005.090.....	IP ADDRESS
255.255.255.000.....	SUBNET MASK
010.003.005.001.....	DEFAULT GATEWAY
010.003.001.098.....	WINS SERVER IP
YES.....	TIMEOUT CHECKING
300.....	TIMEOUT VALUE
000.....	ARP INTERVAL
9100.....	BASE RAW PORT
00074d2b4159.....	MAC ADDRESS
<b>Wireless</b>	
ALL.....	IP PROTOCOL
000.000.000.000.....	IP ADDRESS
255.255.255.000.....	SUBNET MASK
000.000.000.000.....	DEFAULT GATEWAY
010.003.001.098.....	WINS SERVER IP
YES.....	TIMEOUT CHECKING
300.....	TIMEOUT VALUE
000.....	ARP INTERVAL
9100.....	BASE RAW PORT
NO.....	CARD INSERTED
0000H.....	CARD MFG ID
0000H.....	CARD PRODUCT ID
000000000000.....	MAC ADDRESS
YES.....	DRIVER INSTALLED
INFRASTRUCTURE.....	OPERATING MODE
vh-CTC-PRD.....	ESSID
100.....	TX POWER
ON.....	1 Mb/s
ON.....	2 Mb/s
ON.....	5.5 Mb/s
ON.....	11 Mb/s
11 Mb/s.....	CURRENT TX RATE
DIVERSITY.....	RECEIVE ANTENNA
DIVERSITY.....	XMIT ANTENNA
OPEN.....	WEP TYPE
WEP 128-BIT.....	WLAN SECURITY
1.....	WEP INDEX
020.....	POOR SIGNAL
LONG.....	PREAMBLE
NO.....	ASSOCIATED
ON.....	PULSE ENABLED
15.....	PULSE RATE
OFF.....	INTL MODE
07FFH.....	CHANNEL MASK

FIRMWARE IN THIS PRINTER IS COPYRIGHTED

Network Configuration	
Zebra Technologies ZTC ZT620R-203dpi ZPL 76J162700886	
Wired.....	PRIMARY NETWORK
PrintServer.....	LOAD LAN FROM?
INTERNAL WIRED.....	ACTIVE PRINTSRVR
<b>Wired*</b>	
ALL.....	IP PROTOCOL
192.168.000.017.....	IP ADDRESS
255.255.255.000.....	SUBNET
192.168.000.254.....	GATEWAY
000.000.000.000.....	WINS SERVER IP
YES.....	TIMEOUT CHECKING
300.....	TIMEOUT VALUE
000.....	ARP INTERVAL
9100.....	BASE RAW PORT
9200.....	JSON CONFIG PORT
<b>Wireless</b>	
ALL.....	IP PROTOCOL
000.000.000.000.....	IP ADDRESS
255.255.255.000.....	SUBNET
000.000.000.000.....	GATEWAY
000.000.000.000.....	WINS SERVER IP
YES.....	TIMEOUT CHECKING
300.....	TIMEOUT VALUE
000.....	ARP INTERVAL
9100.....	BASE RAW PORT
9200.....	JSON CONFIG PORT
INSERTED.....	CARD INSERTED
02dfH.....	CARD MFG ID
9134H.....	CARD PRODUCT ID
ac:3f:a4:82:05:9c.....	MAC ADDRESS
YES.....	DRIVER INSTALLED
INFRASTRUCTURE.....	OPERATING MODE
125.....	ESSID
1.0.....	CURRENT TX RATE
OPEN.....	WEP TYPE
WPA PSK.....	WLAN SECURITY
1.....	WEP INDEX
000.....	POOR SIGNAL
LONG.....	PREAMBLE
NO.....	ASSOCIATED
ON.....	PULSE ENABLED
15.....	PULSE RATE
OFF.....	INTL MODE
USA/CANADA.....	REGION CODE
USA/CANADA.....	COUNTRY CODE
0x7FF.....	CHANNEL MASK
<b>Bluetooth</b>	
4.3.1p1.....	FIRMWARE
02/13/2015.....	DATE
on.....	DISCOVERABLE
3.0/4.0.....	RADIO VERSION
on.....	ENABLED
AC:3F:A4:82:05:9D.....	MAC ADDRESS
76J162700886.....	FRIENDLY NAME
no.....	CONNECTED
1.....	MIN SECURITY MODE
nc.....	CONN SECURITY MODE
supported.....	iOS

FIRMWARE IN THIS PRINTER IS COPYRIGHTED

**Figure 6 • Sample Network Configuration Label for G-Series or LP/TLP 2824 Plus Printers**

Network Configuration	
Zebra Technologies ZTC GX420d ZBR2941050	
<b>Internal Wired*</b>	
ALL.....	IP PROTOCOL
010.003.004.088....	IP ADDRESS
255.255.255.000....	SUBNET MASK
010.003.004.001....	DEFLT. GATEWAY
010.003.001.098....	WINS SERVER IP
YES.....	TIMEOUT CHECKING
300.....	TIMEOUT VALUE
000.....	ARP INTERVAL
9100.....	BASE RAW PORT
00:07:4d:2c:e0:7a..	MAC ADDRESS
FIRMWARE IN THIS PRINTER IS COPYRIGHTED	

**Figure 7 • Sample Printer Configuration Wristband for HC100**

PRINTER CONFIGURATION	
+000.....	TEAR OFF
CONNECTED.....	USB COMM.
9600,8,N,2,X,N,~,^,,	SERIAL COMM.
ZV54.16.0Z<-.....	FIRMWARE
000.000.000.000....	IP ADDRESS
000000000000	MAC ADDRESS
FIRMWARE IN THIS PRINTER IS COPYRIGHTED	

The IP ADDRESS and MAC ADDRESS fields will have values only if a wired or wireless print server is active.



## Configuration of Wireless Securities



**Important** • A wireless option board must be installed on your printer before you can configure the printer to communicate using a wireless radio card. See [Hardware—Wireless Print Servers on page 15](#) to determine if your printer has a wireless board. See [Firmware—Wireless on page 18](#) for the required firmware version.

You may configure your printer for wireless operation in the following ways:

**Through the Network Setup Wizard.** The Network Setup Wizard is part of the ZebraNet Bridge Enterprise utility. The Network Setup Wizard writes a script for you. On the last screen of the wizard, you may choose to send the script directly to your printer, or you may choose to save the script to a file. The saved file has several purposes:

- The file can be sent to the printer through any available connection (serial, parallel, USB, or wired print server).
- The file can be resent to the printer after the network settings have been restored to factory defaults.
- The file can be sent to multiple printers that will use the same network settings.



**Note** • To configure wired and wireless print servers on the same printer, run the program once for each print server, creating a script for the wired print server and another for the wireless print server.

The ZebraNet Bridge Enterprise utility resides on the User CD for your printer and is available through <http://www.zebra.com/software>. ZebraNet Bridge Enterprise version 1.2.5 or later is required to configure the printer correctly for use.

**Through ZPL script that you write.** Use the ^WX command to set the basic parameters for security type. You can send the command through any available connection (serial, parallel, USB, or wired print server).

Refer to the *Programming Guide for ZPL, ZBI, Set-Get-Do, Mirror, and WML* for more information. A copy of the manual is available at <http://www.zebra.com/manuals> or on the User CD that came with your printer.

**Through Set/Get/Do (SGD) commands.** Begin with `wlan.security` to set the wireless security type. Depending on which security type that you select, other SGD commands will be necessary to specify other parameters. You can send the commands through any available connection (serial, parallel, USB, or wired print server).

Refer to the *Programming Guide for ZPL, ZBI, Set-Get-Do, Mirror, and WML* for more information. A copy of the manual is available at <http://www.zebra.com/manuals> or on the User CD that came with your printer.



**Note** • With printers running APL-I, APL-D, or EPL firmware, the only way to configure wireless settings is through SGD commands.





## View Wireless Status through the Control Panel

After the wireless print server is configured, you may view the wireless status on the printer’s control panel in many cases.

- Printers with an LCD display text or symbols (see [LCD Link Status and Wireless Signal Indicators \(Other Printers\)](#)).
- The HC100 printer does not have an LCD, so the wireless status is indicated by the control panel lights (see [HC100 Wireless Status Indicator Lights](#) on page 43).
- The ZT210, ZT220, ZT230 printers also use control panel lights to indicate the wireless status (see [Network Status Indicator Lights](#) on page 44).



**Note** • Refer to the User Guide for your printer for specific instructions on how to use the control panel.

### LCD Link Status and Wireless Signal Indicators (ZD500)

- **Link Status Indicator**  
The wireless link status indicator appears at the upper right of the LCD, providing a real-time display of the printer’s network status.

Status Indicator	Meaning
	The wireless radio is associated with the WLAN.
	The wireless radio is not associated with the WLAN. Verify that your printer’s wireless settings match those of the WLAN.
	The wireless radio is associated and authenticated to the WLAN.
blank	The printer is checking for a wired print server. The printer is running a wired print server. The wireless print server board is not installed or not installed correctly.

- **Wireless Signal Indicators**  
The wireless signal indicators appears at the upper right of the LCD, providing a real-time display of the signal strength and quality.

Wireless Signal Indicator	Description
	These bars indicate the relative strength of the wireless signal. The more bars shown, the better the connection is between the printer and the network.  If your printer indicates a signal strength but you cannot communicate with the printer from your computer, move the printer to a different location to try to get a better signal strength or signal quality. This situation could also indicate that the printer is associated with, but not authenticated with, your access point.

## LCD Link Status and Wireless Signal Indicators (Other Printers)

This section applies to the *PAX4*, *RPAX4*, *105SL*, *RZ400*, *RZ600*, *ZM400*, *ZM600*, *Xi4*, *R110Xi4*, *105SLPlus*, and *ZE500* printers/print engines

**Link Status Indicator** The wireless link status indicator appears at the bottom left of the LCD, providing a real-time display of the printer's network status.

Status Indicator	Meaning
cycling through characters . o O	The wireless radio card is associated with the WLAN.
underscore —	<ul style="list-style-type: none"> <li>The wireless radio card is not associated with the WLAN. Verify that your printer's wireless settings match those of the WLAN.</li> <li>The firmware on the wireless radio card may need to be updated. See <a href="#">Supported Wireless Radio Cards on page 9</a> for the required firmware versions.</li> </ul>
blank	<ul style="list-style-type: none"> <li>The printer is checking for a wired print server.</li> <li>The printer is running a wired print server.</li> <li>The wireless print server board is not installed or not installed correctly.</li> </ul>





**Wireless Signal Indicators** Depending on which printer/print engine you are using, press the following key to access and scroll through the wireless signal indicators on the LCD:

- The right oval for the *PAX4* and *RPAX4* print engines
- PLUS (+) for the *105SL*, *RZ400*, *RZ600*, *ZM400*, *ZM600*, *Xi4*, *R110Xi4*, *105SLPlus*, and the *ZE500* printers/print engines

Wireless Signal Indicator	Description
<b>SIGNAL STRENGTH</b> and <b>SIGNAL QUALITY</b>	<p>When these indicators display percentages, the wireless radio card is communicating with the network. The higher the number is, the better the connection is between the printer and the network.</p> <p>If your printer indicates a signal strength but you cannot communicate with the printer from your computer, move the printer to a different location to try to get a better signal strength or signal quality. This situation could also indicate that the printer is associated with, but not authenticated with, your access point.</p>
<b>NOISE LEVEL</b>	<p>This number indicates any electrical interference with the wireless signal.</p> <p>If your printer cannot communicate with the network and the noise level is high, move the printer to a location that is free of interference.</p>



















































## HC100 Wireless Status Indicator Lights

The following table shows the wireless status indicator lights for the HC100 printer.

Wireless Status Indicator	Meaning
<p><b>Steady Green</b></p> 	<p>The printer is associated with a wireless network. The signal strength is strong.</p>
<p><b>Flashing Green</b></p> 	<p>The printer is NOT associated with a wireless network. The signal strength is strong.</p>
<p><b>Steady Orange</b></p> 	<p>The printer is associated with a wireless network. The signal strength is weak.</p>
<p><b>Flashing Orange</b></p> 	<p>The printer is NOT associated with a wireless network. The signal strength is weak.</p>

## Network Status Indicator Lights

The following table describes the network status indicator lights that are present on the ZTxxx printers.

Printers with a wired Ethernet option					
					<i>NETWORK light off</i> No Ethernet link is available.
					<i>NETWORK light steady green</i> A 100 Base link was found.
					<i>NETWORK light steady yellow</i> A 10 Base link was found.
					<i>NETWORK light steady red</i> An Ethernet error condition exists. The printer is not connected to your network.
Printers with a wireless option					
					<i>NETWORK light off</i> A radio was found during power-up. The printer is attempting to associate with the network. The light flashes red while the printer associates with the network. The light then flashes yellow while the printer is authenticating with the network.
					
					
					<i>NETWORK light steady green</i> The radio is associated with your network and authenticated, and the WLAN signal is strong.
					<i>NETWORK light flashing green</i> The radio is associated with your network and authenticated, but the WLAN signal is weak.
					<i>NETWORK light steady red</i> A WLAN error condition exists. The printer is not connected to your network.

## Determining the Active Print Server

Most printers can have wired and wireless print servers installed at the same time. However, only one of the installed print servers can be active at any given time.

### Viewing IP Addresses and the Active Print Server

The wired and wireless print servers have different IP addresses. The printer's control panel displays the IP address of the active print server (see [View Wireless Status through the Control Panel on page 41](#)). You can view the printer's web pages and send label formats to the printer through the active print server's IP address.

The network configuration label ([Figure 8](#)) displays the IP addresses of all installed print server devices and indicates the active print server with an asterisk (circled in [Figure 8](#)). To print a network configuration label for wired print servers, see [Printing a Network Configuration Label on page 36](#) or for wireless print servers, see [Configuration of Wireless Securities on page 40](#).

Figure 8 • Active Print Sever on Sample Network Configuration Label

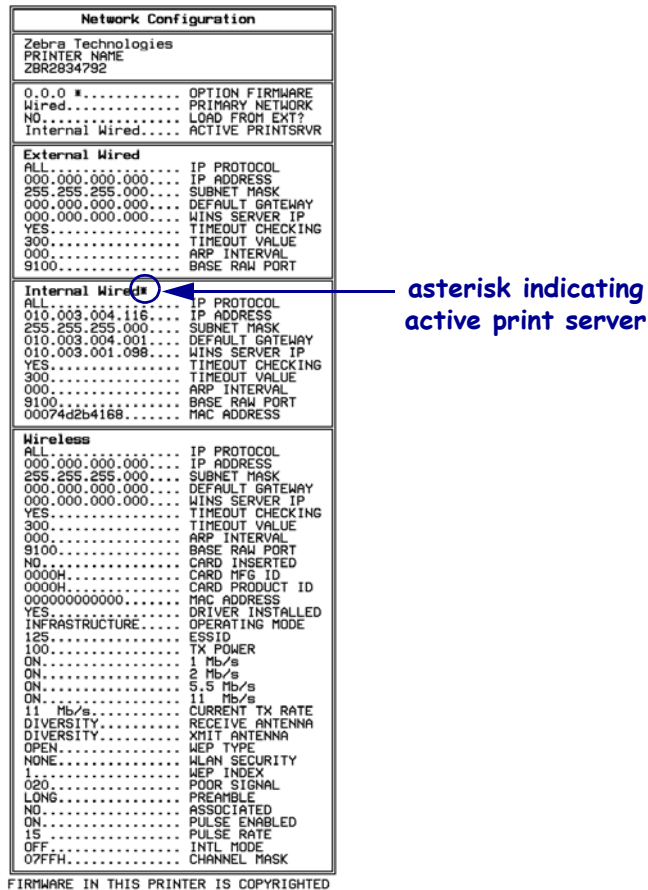

## Active Device Selection

Your active print server selection is dependent on the model of printer or print engine that you have.

If your printer is a(n)...	Then...
<ul style="list-style-type: none"> <li>ZT210, ZT220, ZT230</li> </ul>	<p>Only one print server (wired or wireless) can be installed at a time. Thus, the print server installed is the primary print server.</p>
<ul style="list-style-type: none"> <li>105SL</li> <li>R110PAX4</li> <li>PAX4</li> </ul>	<p>You may select which installed device is the primary network device. The printer will try to use the primary network device as the active print server before trying the other installed options.</p> <p>These printers and print engines use X60.16.x or later firmware. The default for the printer is to <u>skip</u> the check for a wired print server during boot-up. This makes the wireless print server the primary network device if a wireless print server is installed. To change this default and allow the wired print server to be the primary network device when it is connected, use one of the following methods to tell the printer to check for a wired print server at boot-up time:</p> <ul style="list-style-type: none"> <li>the <b>WIRED PS CHECK</b> parameter on the control panel</li> <li>the ^NB ZPL command</li> </ul> <p><a href="#">Table 10</a> identifies which device becomes the active print server under various conditions.</p>
<ul style="list-style-type: none"> <li>105SLPlus</li> <li>R110Xi4</li> <li>RZ400, RZ600</li> <li>Xi4</li> <li>ZD500R</li> <li>ZE500</li> <li>ZM400, ZM600</li> <li>ZT410, ZT420</li> <li>ZT510</li> <li>ZT610, ZT620</li> </ul>	<p>These printers support the simultaneous installation of an internal, external, and a wireless print server. Even though all three print servers may be installed, only one is connected to the network and is the active print server.</p> <p><a href="#">Table 11</a> outlines priorities and identifies which device becomes the active print server when multiple print servers are installed.</p> <p>You may select whether the wired or wireless print server will be the primary connection by using one of the following methods:</p> <ul style="list-style-type: none"> <li>the <b>PRIMARY NETWORK</b> parameter on the control panel</li> <li>the ^NC ZPL command</li> </ul>

**Table 10 • Results of Check for Wired Print Server**

If the Check for Wired Print Server is set to:	Installed and Connected to a Live Ethernet Network		Then the Active Print Server will be:
	Wired	Wireless*	
<b>Skip</b>	X	X	Wireless
	X		Wired
		X	Wireless
<b>Check</b>	X	X	Wired
	X		Wired
		X	Wireless

\* NOTE: A wireless option board must have an active radio that can properly associate to an access point.

**Table 11 • Active Print Server Matrix**

If the Primary Network is set to:	Installed and Connected to a Live Ethernet Network			Then the Active Print Server will be:
	Internal	External	Wireless*	
<b>Wired</b>	X	X	X	Internal
		X	X	External
			X	Wireless
<b>Wireless</b>	X	X	X	Wireless
	X	X		Internal
		X		External

\* NOTE: A wireless option board must have an active radio that can properly associate to an access point.

## Assigning an IP Address on any Print Server

Before you can begin working with a print server, you must get or assign an IP address for the print server device.

The four different ways to assign an IP address are:

- DHCP
- ZebraNet Bridge Enterprise
- Printer Control Panel/LCD
- Telnet



**Important** • For specific information on the default User ID and/or default password, see [Default User ID and Password on page 33](#).

### With Dynamic Host Configuration Protocol (DHCP)

If your network uses DHCP, your print server device is assigned a temporary IP address.



**Note** • Check with your Network Administrator to see whether your network uses DHCP.

### Assigning an IP Address Without DHCP via ZebraNet Bridge

ZebraNet Bridge may be used to set the IP address. Refer to the *ZebraNet Bridge Enterprise User Guide* for more detailed information.

### Assigning an IP address Without DHCP from the Control Panel

These steps can be used with all printers with a control panel.

**To assign an IP address from the control panel (or LCD), complete these steps:**



**Important** • A 10/100 Print Server must have firmware 1.xx.x and higher and your Zebra printer must have firmware x.10 or higher with a control panel.

1. Turn on (I) the printer and wait until the control panel says **PRINTER READY**.
2. See [Wired Network Parameters on the Printer Display on page 114](#) or [Wireless Network Parameters on the Printer Display on page 116](#) for specific print server menu options or your printer's user guide for specific instructions on the operation of your printer.
3. You may edit any of the following network settings in order to communicate with any print server in your network environment.



**Important** • To change any of these settings, you need to enter the printer password. The default password is 1234.



- `ip resolution` (dynamic, permanent) The printer menu item **IP RESOLUTION** must be set to **PERMANENT** if attempting to assign the IP address from the control panel.
- `default gateway` (default setting of 000.000.000.000)
- `subnet mask` (default setting 255.0.0.0)
- `ip address` (if initial default setting is 0.0.0.0, after 2 minutes this defaults to **192.168.254.254**)
- `ip protocol` (gleaning only, RARP, BOOTP, DHCP, DHCP and BOOTP, all)

## Assigning an IP Address Without DHCP via a Telnet Session

The methods used for assigning an IP address with a Telnet session are Static Route and Gleaning.



**Important** • This applies to any TCP/IP capable workstation/host networked with the Zebra printer. Both, the workstation/host and the print server, must be on the same network segment.

Before you can Telnet to the print server and configure it, you must first assign the print server a temporary IP address.

### Static Route

#### To use this method, complete these steps:

1. Turn on (I) the printer and wait for 2 minutes to allow for the device to complete the self-test.

During this time, the print server performs an address broadcast. If no address is assigned to the unit (via DHCP or BootP), it uses a default address. The default address for print server is **192.168.254.254**. Print the print server configuration label to confirm the address. For details, see *Before You Begin* on page 33.

2. You can use the `route add` command to place the default IP address into the workstation's network routing table.
3. At the workstation/host command prompt (in Windows, at the DOS prompt), type:

```
route add **** "IP address of the workstation" 0
      where **** is the IP address on any print server configuration label
```



**Note** • The zero (0) placed at the end of the “route add” command is optional on some systems.

4. Telnet to the print server by typing:  

```
"Telnet xxx.xxx.xxx.xxx"
```

The password is 1234.
5. At this point, you can alter the settings as desired. When complete, do a reset and allow the print server self-test to complete before proceeding with any communications activity.

## Gleaning

A method by which the print server uses the IP address of the first ping packet that is sent to its hardware address.



**Note** • Gleaning works **only** on local subnets at routers. It does not pass Address Resolution Protocol (ARP) broadcasts.

### To use this method, complete these steps:

1. Add an entry to the ARP table that assigns an IP address to an Ethernet (hardware) address.

The syntax for this command is:

```
arp -s <temporary ip address> <MAC Address>
```



**Example** • You would type: `arp -s 10.3.50.59 00-07-4d-1D-B9-86`

2. Power cycle the printer.
3. As the printer reboots, begin a continuous ping to the address assigned previously.



**Note** • Most UNIX systems use a continuous ping.

To use a continuous ping from a Windows host, you must issue the following command:  
`ping -t "ipaddress"`

4. When the print server begins to respond, stop the ping activity.  
In Windows, Ctrl + C halts the pinging.
5. Telnet to the print server and assign the appropriate IP address, subnet mask, and gateway, if applicable.
6. Once this is complete, reset the print server.

For details on resetting the print server, see [Reset on page 110](#).

## Setting and Monitoring Alerts on Any Print Server

It is important to understand the relationship between the print server and the printer when you are establishing alerts. Here are the relationships you need to be aware of:

- Non-ZebraLink-enabled printers — can only send alerts on a specific set of printer errors that are reported in the IEEE 1284 protocol.
- ZebraLink-enabled printers — ZebraLink allows for the printer to send alerts outside of the IEEE 1284 protocol.

### Using ZebraNet Bridge

ZebraNet Bridge may be used to set and monitor alerts. Refer to the *ZebraNet Bridge Enterprise User Guide* for more detailed information.

### ZebraLink Alerts

ZebraLink Alerts give you the ability to manage your Zebra printers by immediately notifying System Administrators of printer error or warning conditions, which reduces printer downtime and increases application efficiency. Using Web-based configuration tools, selected errors or warning conditions can be routed to a variety of destinations such as email messages, wireless pagers, or ZebraLink Alerts.

[Table 12 on page 52](#) shows the conditions that can trigger alerts and the possible destinations.

**Table 12 • ZebraLink Alerts and Destinations**

<b>Alert Type</b>	<b>Error Condition</b>
<b>10/100 Print Server Alerts</b>	<ul style="list-style-type: none"> <li>• On-line (condition clear)</li> <li>• Off-line</li> <li>• Paper out</li> <li>• Printer error</li> </ul>
<b>ZebraLink Alerts</b>	<ul style="list-style-type: none"> <li>• Media out</li> <li>• Ribbon out</li> <li>• Printhead over-temp warning</li> <li>• Printhead under-temp warning</li> <li>• Head open</li> <li>• Power supply over-temp</li> <li>• Ribbon warning (in direct-thermal mode)</li> <li>• Rewind full</li> <li>• Cut error</li> <li>• Printer paused</li> <li>• PQ job completed</li> <li>• Label taken</li> <li>• Head element out</li> <li>• ZBI (Zebra BASIC Interpreter) runtime error</li> <li>• ZBI (Zebra BASIC Interpreter) forced error</li> <li>• Clean printhead</li> <li>• Media low</li> <li>• Ribbon low</li> <li>• Replace head</li> <li>• Battery low</li> <li>• RFID error</li> <li>• All errors (in RFID printers only)</li> <li>• All errors (in non-RFID printers only)</li> <li>• Power on</li> </ul>
<b>ZebraLink Alerts Destinations</b>	<p>Unsolicited Alert messages can be directed to the following destinations:</p> <ul style="list-style-type: none"> <li>• Email (10/100 Print Server-specific)</li> <li>• TCP (10/100 Print Server-specific)</li> <li>• UDP (10/100 Print Server-specific)</li> <li>• SNMP (10/100 Print Server-specific)</li> <li>• Serial *</li> <li>• Parallel *</li> <li>• USB *</li> </ul>

\* Available in ZebraNet Bridge

## Using WebView

This section has step-by-step instructions for setting up an alert using ZebraLink™ WebView.



**Important** • If you do not have a ZebraLink-enabled printer, these steps will not work.

### To begin receiving notification of errors, complete these steps:

1. Open a Web browser.
2. In the Address text-box, type in the printer's IP address.

The Printer Home Page opens.

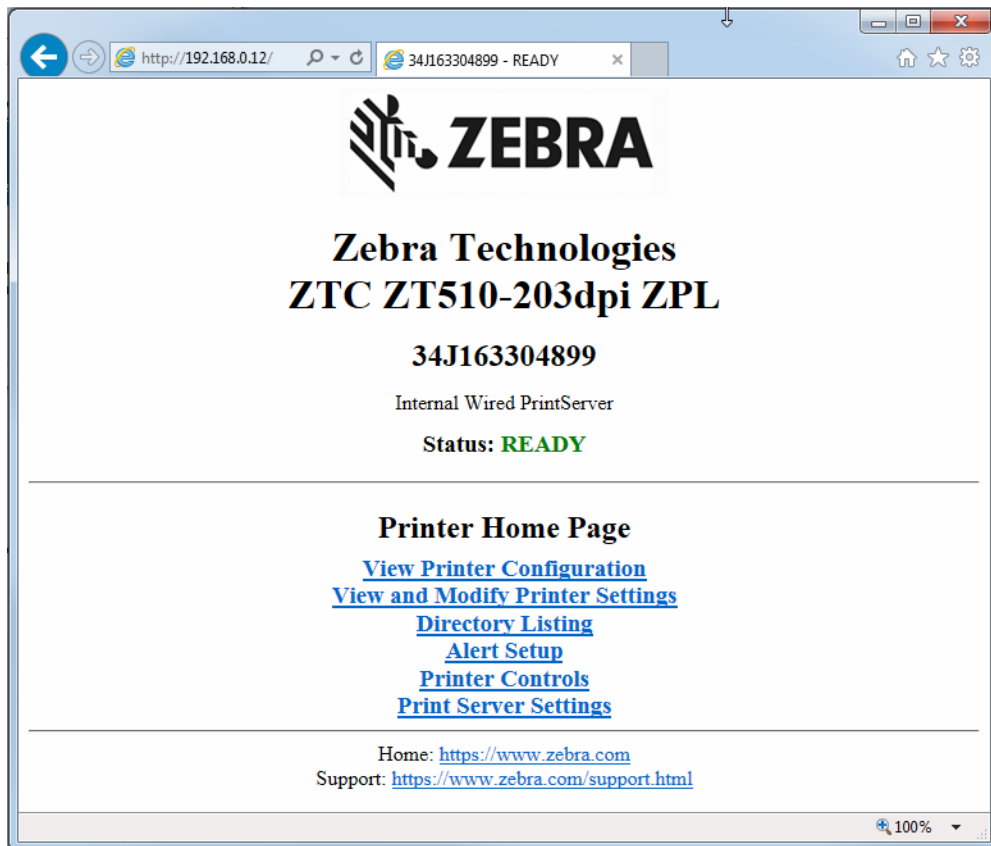

**Note** • Your printer firmware determines how this page looks. This page is from a printer with firmware x.15 and above.

- From the *Printer Home Page*, click Alert Setup.  
The Alert Setup page shows a list of message notifications and their respective destinations.

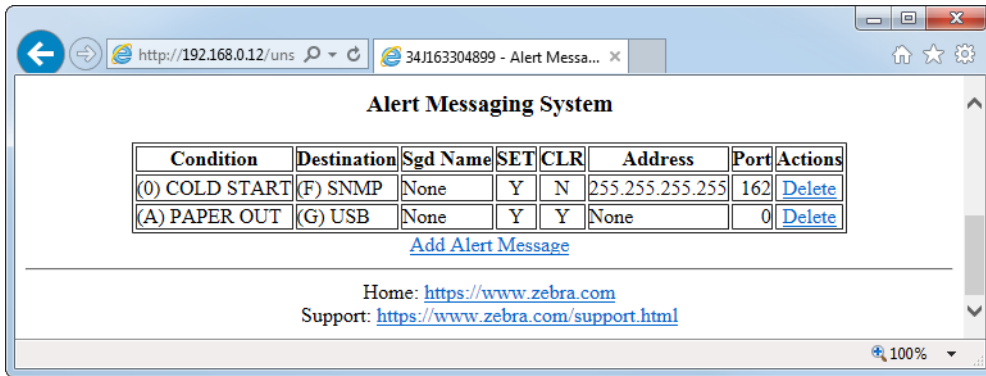

- To set up notifications, go to the Alert Setup page and click Add Alert Message.



**Important** • The printer accepts only the last configuration made.

The Add Alert Message page opens.

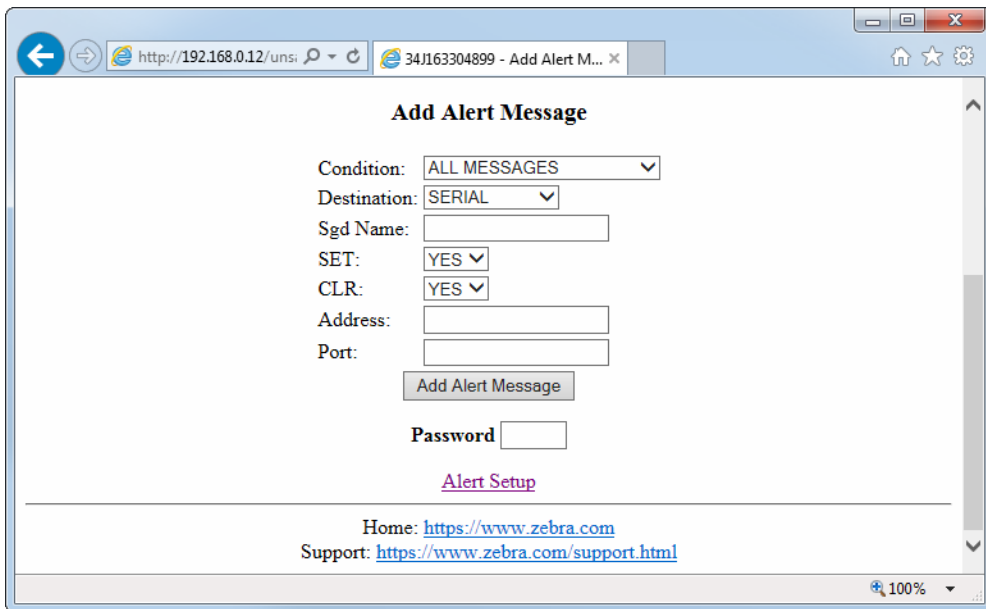

- Specify the condition to send, such as **HEAD OPEN** or **PAPER OUT**.
- Set destination.
- In the SET drop-down box, select YES.  
You will be notified whenever your specific condition is detected.
- In the CLR drop-down box, select YES if you wish to be notified when the specific condition is cleared.

9. If you selected email for your destination, enter a valid email address to which your messages will be sent.

To receive email alerts, you must give your print server the IP address of your mail server running SMTP. For instructions, refer to [Status and Configuration on page 100](#).

10. If you selected TCP or UDP for your destination, enter the Port Number.



**Important** • A password is required. If you forget to enter the password, the alerts you just set are deleted.

11. Enter the printer password.
12. Click Add Alert Message.  
The printer processes your Add Message command.
13. To save current settings, click Save Printer Settings.
14. Click Submit Changes.

## Checking Print Server Configuration Settings

This section provides steps on how to check the print server configuration settings.

### Using ZebraNet Bridge

ZebraNet Bridge may be used to check the print server configuration settings. Refer to the *ZebraNet Bridge Enterprise User Guide* for more detailed information.

### Using WebView

This section provides steps on how to check any print server configuration settings using its Web pages.

**To access the print server settings, complete these steps:**

1. Open a Web browser.
2. In the Address text-box, type your printer's IP address, and then press Enter.  
The Printer Home Page opens.

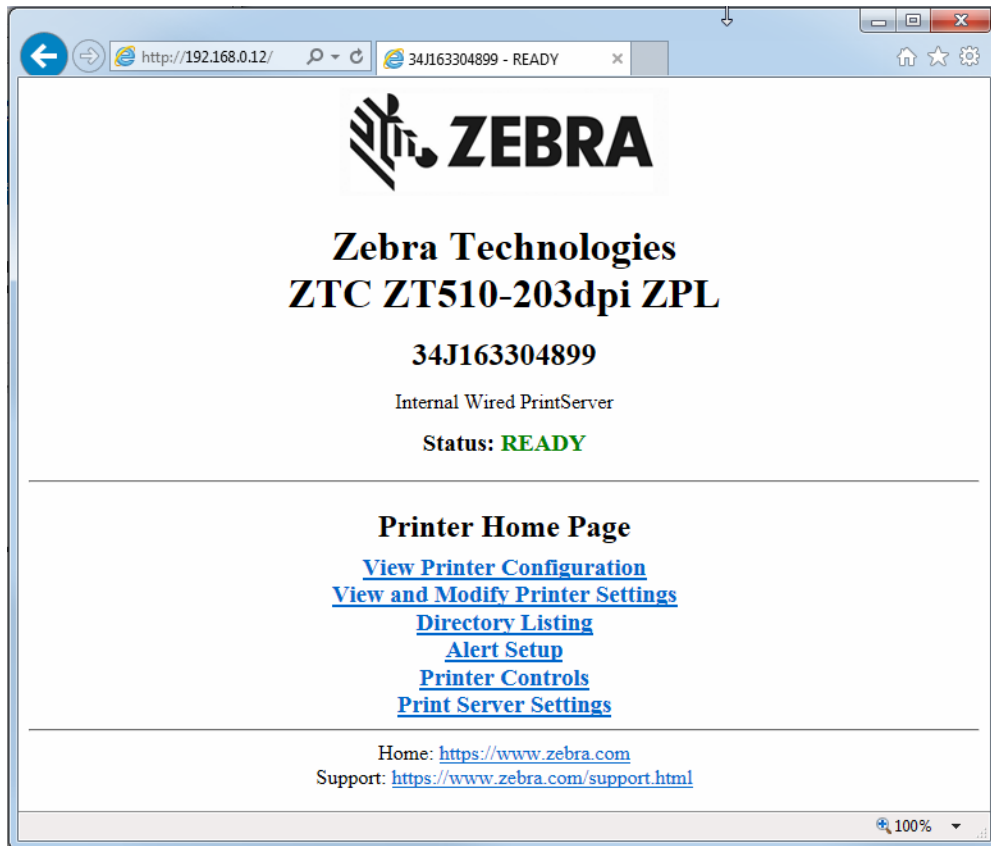



3. From the Printer Home Page, click Print Server Settings.  
The default User ID and password are required.



**Important** • For specific information on the default User ID and/or default password, see *Default User ID and Password* on page 33.

The Print Server Status and Configuration Page opens.

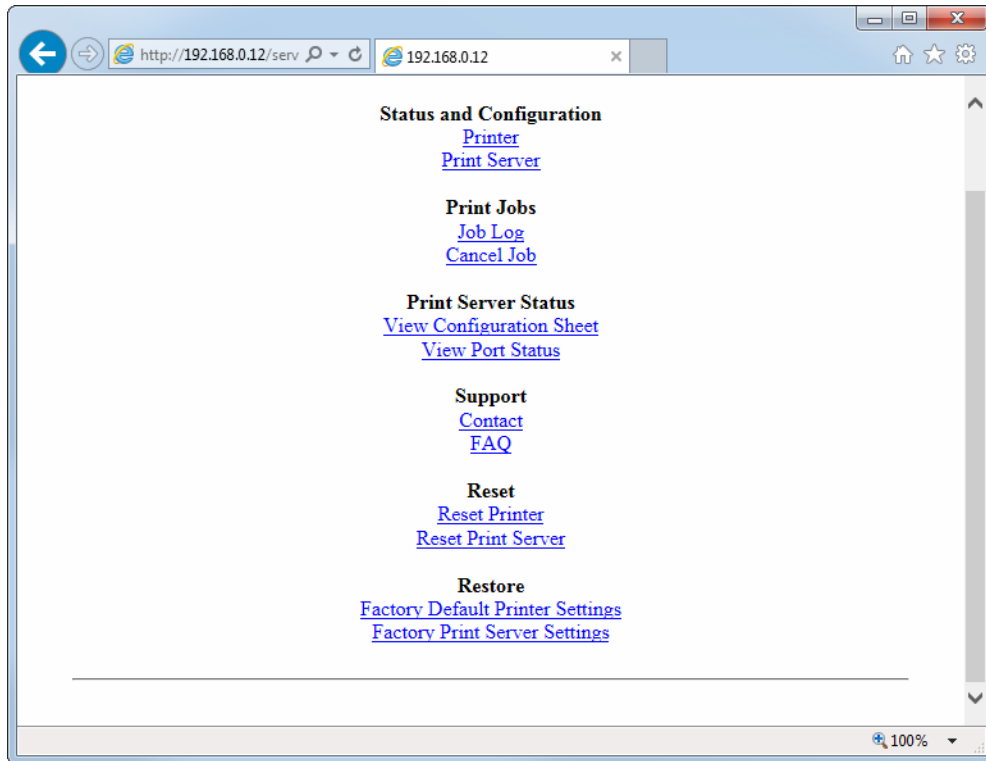

4. From the Print Server page, click Print Server.  
The Print Server Configuration page opens.

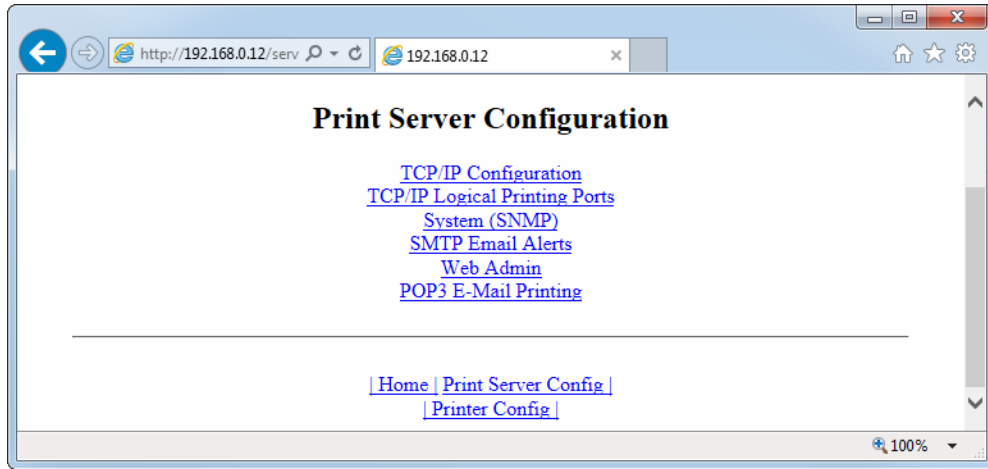

## Enabling Protocols

This section contains directions for accessing protocols using WebView.

### Using WebView

To enable protocols using WebView, complete these steps:

1. Open a Web browser.
2. In the Address text-box, type your printer's IP address, then press Enter.  
The Printer Home Page opens.

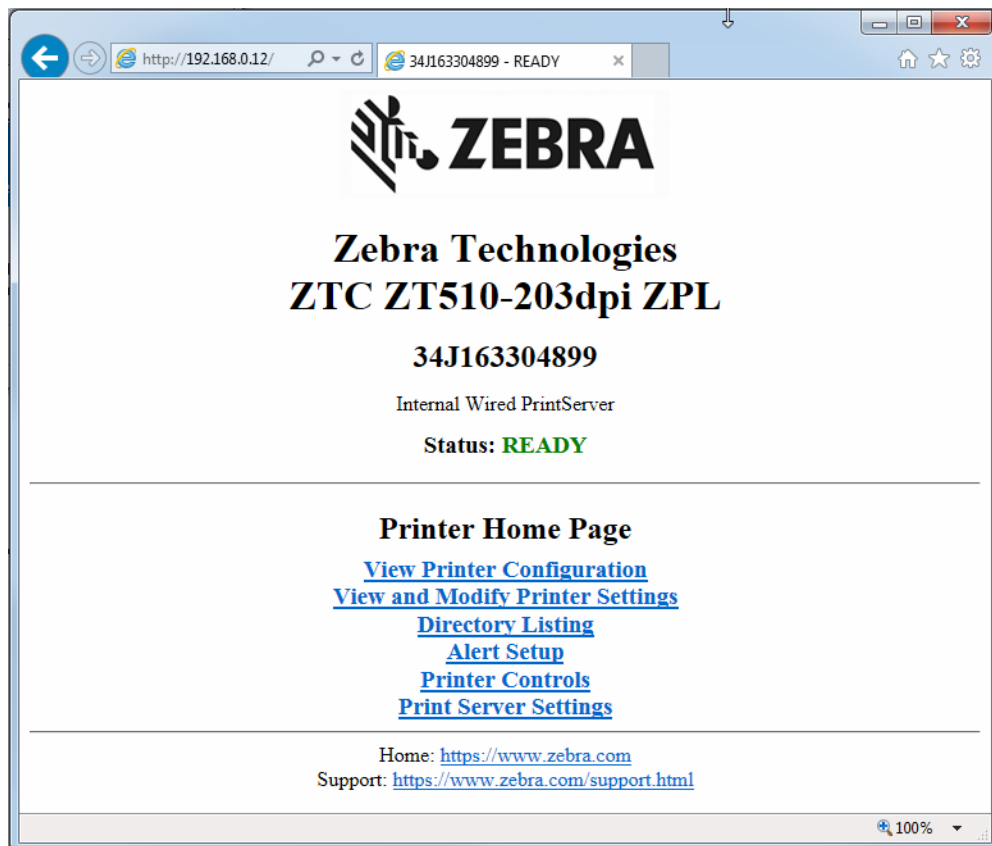

- From the Printer Home Page, click Print Server Settings.  
The default User ID and password are required.



**Important** • For specific information on the default User ID and/or default password, see [Default User ID and Password on page 33](#).

- From the Print Server page, click Print Server.  
The Print Server Configuration page opens.

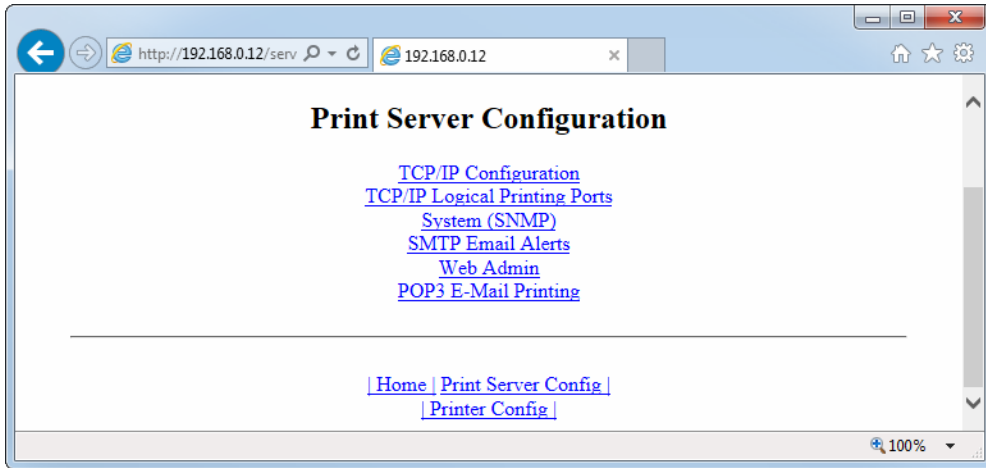

- From the Print Server Configuration page, click Enabled Protocols. (Not shown on previous screen because of printer model or options.)  
The Protocol Configuration page opens.

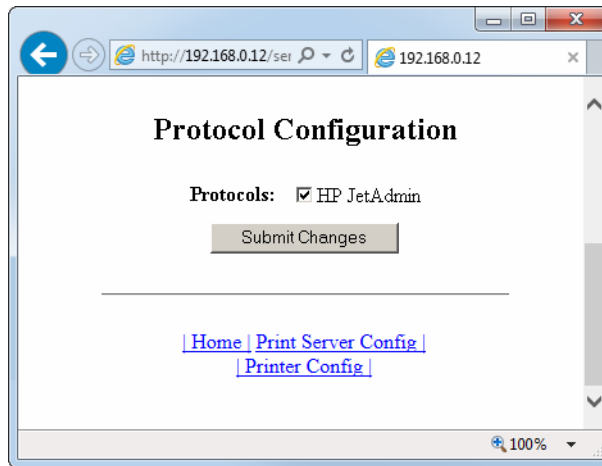

- Select the protocols you want to enable, then click Submit Changes.  
You get a confirmation to reset the unit for changes to take place.

# Defaulting ALL Print Servers

## Using WebView

To default the print server to factory settings using WebView, complete these steps:

1. From the Printer Home Page, click View and Modify Printer Settings.  
The View and Modify Printer Settings page opens.

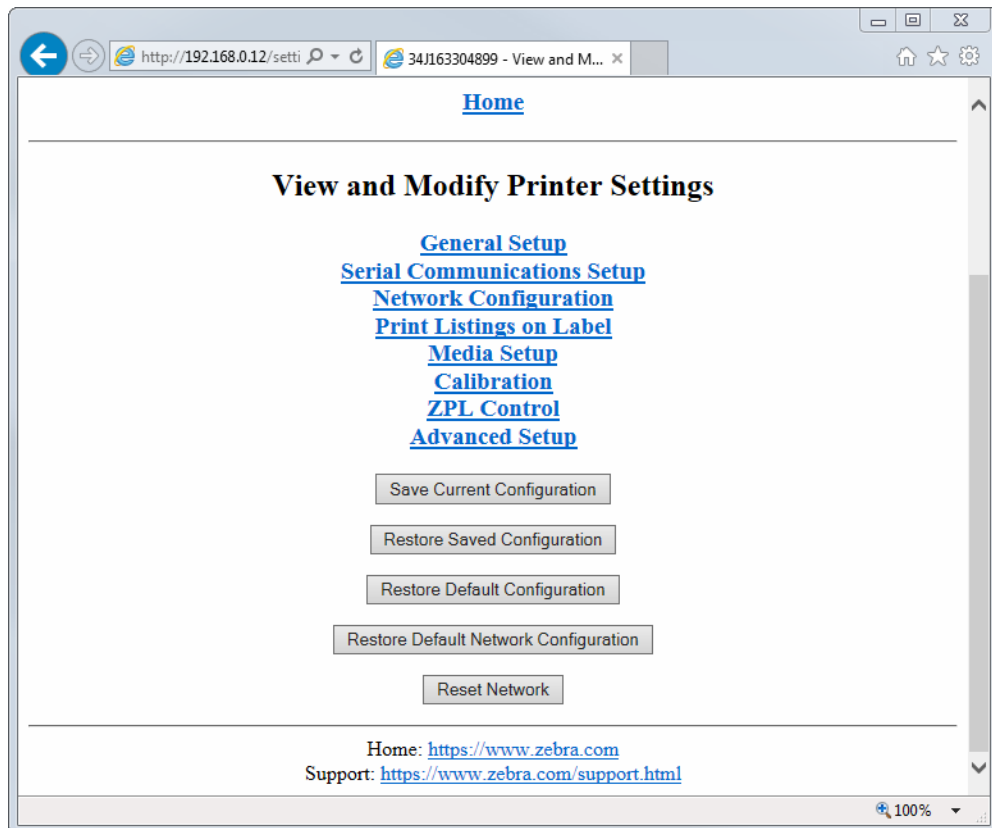

2. Click Restore Default Network Configuration.  
The default network settings are restored.

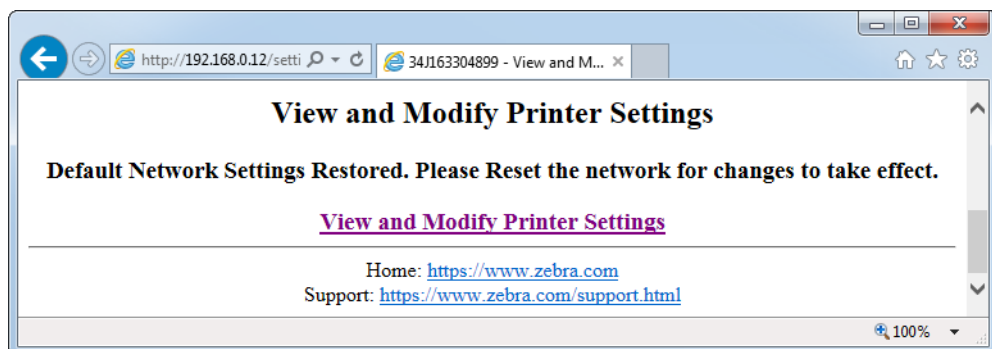

3. Click View and Modify Printer Settings to return to the View and Modify Printer Settings page.
4. Click Reset Network.  
The network has been reset and the default values saved.



**Important** • During the reset cycle, the web pages are unavailable. Upon completion, check the print server IP address as it may have changed during the reset cycle.

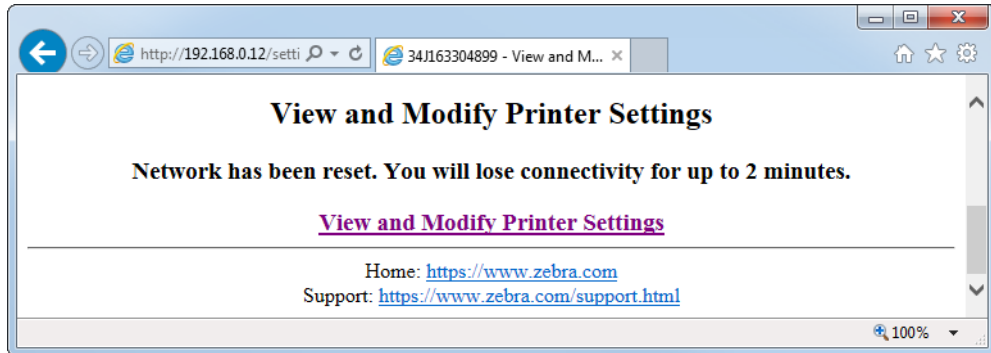

## Using ZebraNet Bridge

ZebraNet Bridge may be used default the print server to factory settings. Refer to the *ZebraNet Bridge Enterprise User Guide* for more detailed information.

## Using a ZPL Command

Issue the ZPL command shown immediately below or refer to the *ZPL II® Programming Guide for ZPL II, ZBI 2, Set-Get-Do, Mirror and WML* for further details.

```
^XA^JUN^XZ
```



**Note** • To download a copy of either of the guides mentioned above, visit the Zebra web site at: [www.zebra.com/manuals](http://www.zebra.com/manuals).



## Defaulting a 10/100 Print Server



The Test button is accessed via a small recessed hole on the back of the external 10/100 Print Server device (see [Figure 2 on page 25](#)). To press the Test button, you need to insert something small into the hole, like the end of a paper clip.

For the internal 10/100 Print Server device, the Test button is located on the back of printer.

### To default the 10/100 Print Servers to factory settings using the Test button, complete these steps:



**Note** • You must have an active network cable connected to the external 10/100 Print Server device to default the device using the Test button.

1. Turn off (O) the printer.
2. With the printer turned off, press and hold the Test button on the 10/100 Print Server device and turn on (I) the printer.
3. The status indicator tells you when 10/100 Print Server has been reset to factory defaults, as follows:
  - If an active network cable is connected to the 10/100 Print Server, the status indicator turns solid green.
  - If there is **not** an active network cable connected to the 10/100 Print Server, the status indicator flashes red.
4. Release the Test button.

For more details on status indicators, see [External 10/100 Print Server Network Status and Status Indicators on page 120](#).



## Defaulting the Print Servers on the LP/TLP 2824 Plus and G-Series Printers



To default the print server to factory settings, complete these steps:



**Note** • Be sure to count the number of LED flashes.

1. Hold Feed until you see a sequence of four green flashes.
2. Release Feed and the LED will immediately flash amber once.



**Important** • If you do not press Feed the second time (in [step 3](#) below), you will default the **printer** only.

3. Press and hold Feed again to enter the Default submenu.  
The flash sequences represent various devices to default:
  - One green flash: Defaults the print server only
  - Two green flashes: Defaults the printer only
  - Three green flashes: Defaults both, the printer and the print server
4. Release Feed when you see the flash sequence that corresponds to the desired default.



## Defaulting the Print Servers on the HC100 Printers



To default the print server to factory settings, complete these steps:

1. Press and hold Feed for two seconds.



**Note** • Be sure to count the number of LED blinks. The three blink sequence defaults **only** the print server parameters while the four blink sequence defaults **all** of the printer parameters.

2. Wait for the three blink sequence of the Error/Status LED.
3. Release Feed.



## Defaulting the Print Servers on the ZM400 and ZM600 Printers



To default the print server to factory settings using the control panel on the ZM400 or ZM600 printers, complete these steps:

1. From the control panel, press SETUP/EXIT two times.
2. Press PLUS (+ button) until the control panel displays **DEFAULT NET**.
3. Press SETUP/EXIT to save the change.

After the printer defaults all settings, the control panel will show **PRINTER READY**.





## Defaulting the Print Servers on 105SL, PAX4, Xi4, ZE500, and 105SLPlus Printers

To default the print server to factory settings, complete these steps:

1. From the control panel, press SETUP/EXIT two times.
2. Press PLUS (+ button) until the control panel displays **DEFAULT NET**.
3. Press NEXT/SAVE to save the change.  
The control panel will read **PRINTER READY**.



## Defaulting the Print Servers on the ZD400, ZD500R, and ZTxxx Printers

1. Turn off (O) the printer.
2. Press and hold the PAUSE and CANCEL keys and turn on (I) the printer.
3. Hold the PAUSE and CANCEL keys until the first status indicator light turns off.  
The printer resets the print servers to their defaults. For more information on the network status after loading defaults, see [Network Status Indicator Lights on page 44](#).
4. For these printers that also have a control panel display, you may also use the TOOLS> LOAD DEFAULTS > NETWORK user menu item to default the print servers. Refer to the User Guide for your printer for specific instructions.



# Printing Queues

This section provides information and instructions on configuring your printer for use with a BSD or System V Queue.

## Contents

Berkeley Software Distribution (BSD)-Style Print Queue. . . . .	68
Configuring the Print Queue . . . . .	68
System V Queue Installation . . . . .	69
Configuring Operating System V Queue for Printing . . . . .	69
Prerequisites . . . . .	69
UNIX Configuration . . . . .	69

## Berkeley Software Distribution (BSD)-Style Print Queue

BSD is a version of the UNIX OS that distributes software that includes TCP/IP.

### Configuring the Print Queue

For remote BSD-style LPD printing, add the print server as a remote printer in the `/etc/printcap` database to each host printing to any print server. You can add printcap options as needed. If you are unfamiliar with these options, consult the printer documentation.



**Important** • You must be logged in as `root`.

The entry looks similar to this:

```
local_print_queue_name|[printer_model_and_manufacturer]:\  
:lp=:mx#0:rm=printserver_name:\  
:rp=remote_print_queue_name:\  
:sd=path_to_spool_directory:lf=just log_file_name
```

`local_print_queue_name` — This defines the name of the printcap entry. It is used by the LPR/LPD utilities to specify which printcap entry is being referenced. Additional printcap entries can be added as needed for different queue types. Each entry must have a unique `local_print_queue_name` and a different spool directory to work properly. When you are ready to print, use the `local_print_queue_name` that matches the data type of the file to be printed.

`printserver_name` — This is the name (alias) of the print server. This must be the same name as entered in the `/etc/hosts` file or your NIS or DNS system. An IP address may also be used here.

`remote_print_queue_name` — This entry determines the port where the print job will be printed and optionally specifies ASCII printing that must end for LF1.

`path_to_spool_directory` — This is the path to a directory where the print jobs will be spooled for this queue. You must create a unique spool directory for each printcap entry.

`log_file_name` — This is the path to a file where error information from the LPD will be logged.



**Example** • Your printcap entries might look similar to this:

```
Ascii_files|form.feed.Queue_on_Port_1:\  
:lp=:mx#0:rm=pserver1:rp=MYQUEUELF1:\  
:sd=/usr/spool/myqueueelf1:\  
:lf=/usr/spool/myqueueelf1/queue.log
```



**Important** • Each printcap entry must have a different spool directory to work properly.

## System V Queue Installation

### Configuring Operating System V Queue for Printing

This section describes the configuration of the printing system on the UNIX operating system. For clarity and brevity, the following specific names are used to represent general devices or concepts.

`lj4` — The local queue name on the UNIX system to which you want print server print jobs directed.

`ZEBRAPRINTER` — The host name or IP address of the remote system that is the print server device. For example, to Telnet to any print server and invoke the print server configuration utility, you would enter:

```
Telnet ZEBRAPRINTER
```

A host name is not required for the print server — the IP address can be used.

`yourqueuename` — This is the name of the queue, which must end with `LF1`.

### Prerequisites

Before you proceed, the following prerequisites must be met:

- The name `ZEBRAPRINTER` and the IP address assigned to the print server are in the `/etc/hosts` file on the UNIX system.
- The LPD must be running on the UNIX system.

### UNIX Configuration

**To configure the UNIX machine so users can spool print jobs to the PCL print queue on the print server named `ZEBRAPRINTER`, complete these steps:**

1. Log in to the UNIX machine as root.

2. Type:

```
lpsystem -t bsd ZEBRAPRINTER
```

3. Type:

```
lpadmin -p lj4 -s ZEBRAPRINTER!yourqueuename - I any
```

4. Type:

```
accept lj4
```

5. Type:

```
enable lj4
```

6. Try printing by typing the command:

```
lp -d lj4 [filename]
```



**Notes •** \_\_\_\_\_

\_\_\_\_\_

\_\_\_\_\_

\_\_\_\_\_

\_\_\_\_\_

\_\_\_\_\_

\_\_\_\_\_

\_\_\_\_\_

\_\_\_\_\_

\_\_\_\_\_

\_\_\_\_\_

# Using Printing Protocols

In this section, you are given steps to set up your print server to support **I**nternet **P**rinting **P**rotocol (IPP) and **F**ile **T**ransfer **P**rotocol (FTP).

## Contents

IPP .....	72
FTP .....	73



## IPP



**Important** • You must have IPP support on your system.

Internet Printing Protocol (IPP) is an application-level protocol used for distributed printing over the Internet. Using IPP from any standard IPP client, you can transfer jobs to a printer that is connected to either a 10/100 Print Server.



**Important** • IPP support is not available on all 10/100 Print Server printers. To be certain that you are running the latest version of firmware, visit <http://www.zebra.com>.

### To set up your 10/100 Print Server to support IPP, complete these steps:

1. Open a browser.
2. Enter the 10/100 Print Server IPP URL as follows:  
`http://xxx.xxx.xxx.xxx:631/ipp/port1`  
`xxx.xxx.xxx.xxx` = the IP address of the 10/100 print server device  
`:631` = a fixed value  
`/ipp` = a fixed string designating IPP  
`/port1` = a fixed value



**Example** • Your address might look like this:

`http:198.60.248.120:631/ipp/port1`



## FTP

Embedded within the print server is an FTP server application that processes file transfers from a host computer to the printer.

If the printer is on a network, label formats can be generated and data can be transferred without setting up a print queue.

### To send information to the printer, perform these steps:

1. Open a command prompt and type:

```
ftp <IP of PS>
```



**Example** • If the IP address of your print server device is 12.3.4.123, you would type:

```
ftp 12.3.4.123
```

This opens a session with the FTP server.

2. Type your user name and press Enter.



**Note** • By default, there is no user name.

3. Type:

```
put < filename>
```

where filename is the location and filename of your ZPL script

This transfers the file to the printer, and the printer generates a label.

4. To terminate the FTP session, type:

```
quit
```



**Notes •** \_\_\_\_\_

\_\_\_\_\_

\_\_\_\_\_

\_\_\_\_\_

\_\_\_\_\_

\_\_\_\_\_

\_\_\_\_\_

\_\_\_\_\_

\_\_\_\_\_

\_\_\_\_\_

\_\_\_\_\_

# ZebraLink WebView

This section describes the ZebraLink WebView functionality on your ZebraLink-enabled printer with a print server.

## Contents

WebView .....	76
Home Page .....	76
View Printer Configuration .....	78
View and Modify Printer Settings .....	80
Network Communications Screens .....	86
Directory Listing .....	93
Printer Controls .....	97

## WebView

WebView provides the System Administrator or user complete, easy, one-step control over the printing environment. It provides real-time configuration, control, and monitoring capabilities with the convenient graphic interface of a Web browser.

The Web pages returned by Zebra printers are not static. They contain real-time information about the printer's present state of operation, including on-line status, error conditions, and all printing parameters.

### Home Page



**Note** • To access the printer's Web page, you need the IP address. For instructions on getting the IP address, see [Assigning an IP Address on any Print Server on page 48](#).

The Home Page is the first Web page that opens. It is a page with a menu of hyperlinks. Each hyperlink allows you to make modifications to the printer, print server, and network settings. The other changeable settings on the Home Page include:

- Network Status, Error and Warning reports
- Print server configuration
- Printer settings
- Directories of objects stored in Flash memory and RAM devices
- Objects, stored fonts, images, programs, and formats
- Zebra Technologies support and home pages

**To open the WebView of your printer, complete these steps:**

1. Open a Web browser.
2. In the Address text-box, type your printer's IP address, and press Enter.  
The Printer Home Page opens.

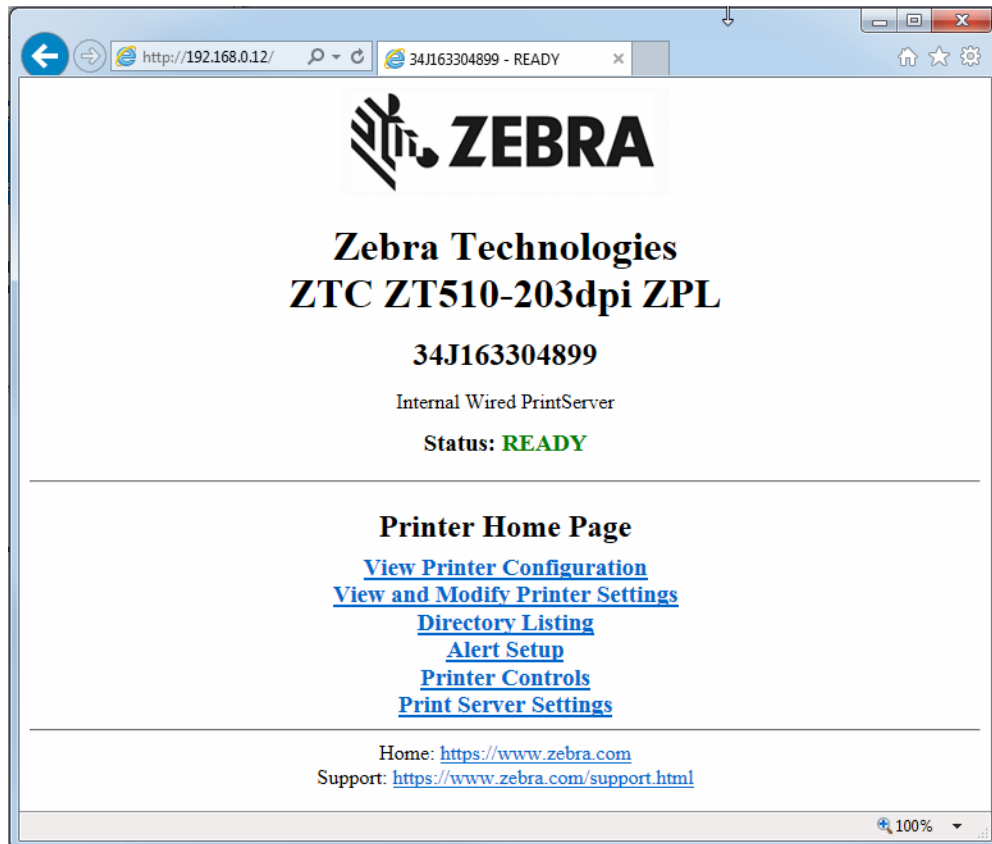

## View Printer Configuration

The View Printer Configuration menu option provides accurate, up-to-the-minute information on the printer's current state. An administrator can conveniently find any information on the Virtual Configuration Label and also check on the status of printer ports.

**To see the View Printer Configuration menu option, complete these steps:**

1. From the Printer Home Page, click View Printer Configuration.

The WebView displays the configuration settings.

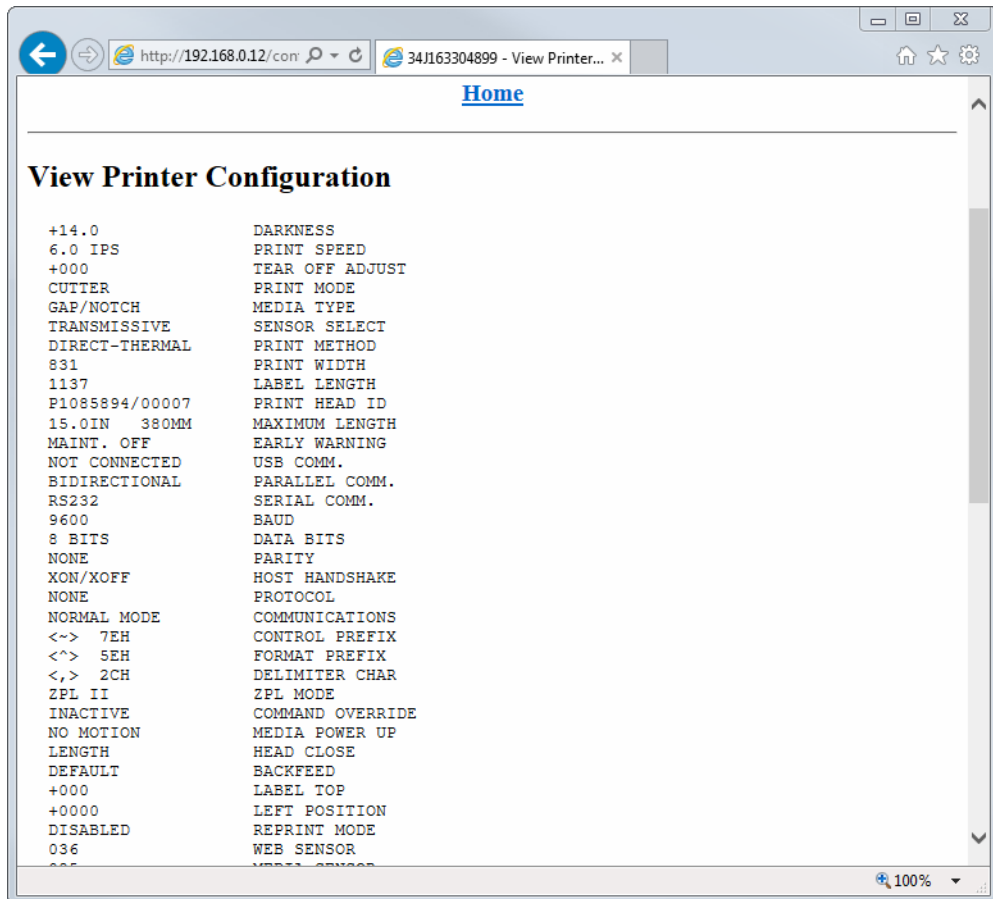

2. To update the printer information from this view, click Refresh and the printer sends current information to the Web browser.
3. When you are finished reviewing:

<b>If...</b>	<b>Then...</b>
You want to return to the Home page	Click the Home link.
You want to print a label	Scroll to the bottom of this page and click Print Label.

## View and Modify Printer Settings

This section provides you with steps for accessing and modifying printer settings with a ZebraLink-enabled printer. It also provides illustrations of the various pages you can access.

To apply changes made in this section, the default User ID and password are required.



**Important** • For specific information on the default User ID and/or default password, see [Default User ID and Password on page 33](#).

### To view and modify printer settings, complete these steps:

1. From the Printer Home Page, click View and Modify Printer Settings.

The View and Modify Printer Settings page opens.

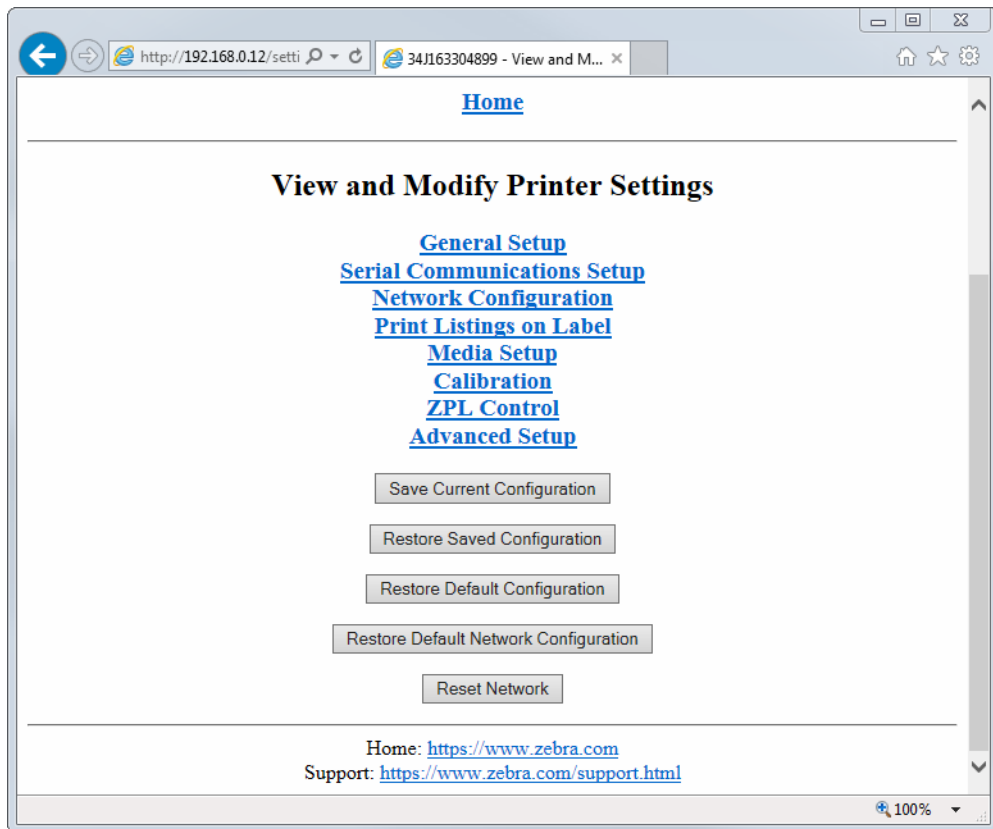

On the View and Modify Printer Settings page, you have a menu to choose from (Table 17).



**Note** • Some options are not available on all printers.



Table 17 • View and Modify Printer Settings Submenus

General Setup

**General Setup**

**Printer Name**  
34J163304899

**Printer Description**  
[Empty]

**LANGUAGE**  
ENGLISH

**DARKNESS**  
Range 0.0 to 30.0  
14.0

**PRINT MODE**  
CUTTER

**TEAR OFF ADJUST**  
Range -120 to 120  
0

**PRINT SPEED**  
6 IPS

**LABEL TOP**  
Range -120 to 120  
0

Submit Changes  
Reset Changes

Home: <https://www.zebra.com>  
Support: <https://www.zebra.com/support.html>

Serial Communications Setup

**Serial Communications Setup**

**BAUD**  
9600

**DATA BITS**  
8 BITS

**PARITY**  
NONE

**HOST HANDSHAKE**  
XON/XOFF

**SERIAL COMM.**  
RS232

Submit Changes  
Reset Changes

Home: <https://www.zebra.com>  
Support: <https://www.zebra.com/support.html>

Table 17 • View and Modify Printer Settings Submenus (Continued)

Network Configuration

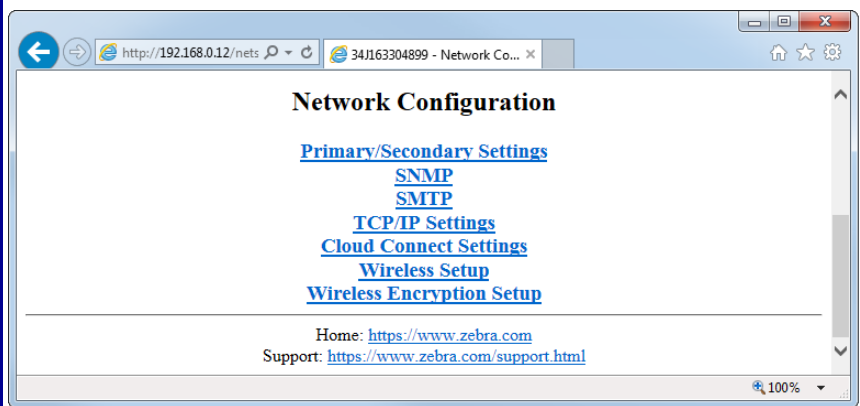

Print Listings on Label

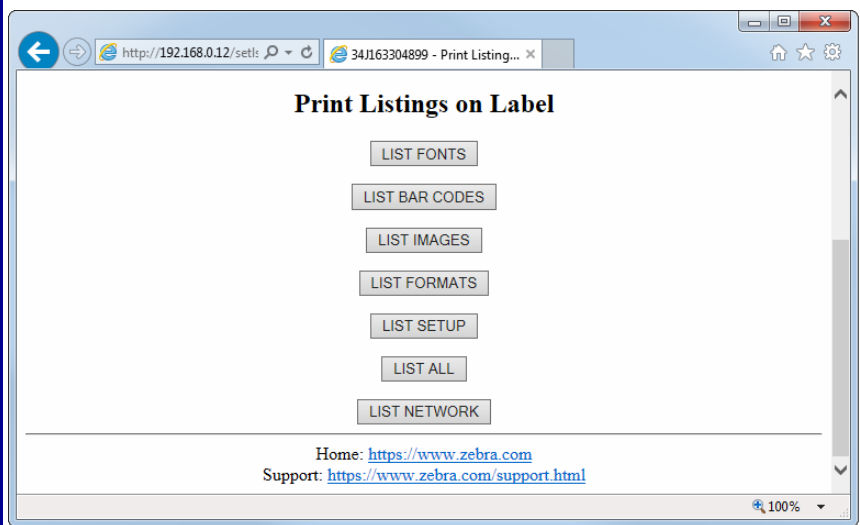

Table 17 • View and Modify Printer Settings Submenus (Continued)

**RFID Setup**  
(RFID Printers/Print Engines only)

The screenshot shows a web browser window with the URL `http://192.168.0.12/setg`. The page title is "RFID Setup". The settings are as follows:

- DETECT MULTIPLE TAGS**: NO
- BLOCK RETRIES**: Range 0 to 10, value 6
- RFID TAG TYPE**: Gen2
- VOID PRINTOUT LENGTH**: Range 0 to 419, value 419
- VOID PRINT SPEED**: 10 IPS
- NUMBER OF LABEL TRIES**: Range 1 to 10, value 3
- ERROR HANDLING**: NO ACTION
- SIGNALS ON APPLICATOR**: SINGLE
- RFID READ PWR**: Range 0 to 30, value 17
- RFID WRITE PWR**: Range 0 to 30, value 18
- RFID PASSWORD**: Range 0 to FF Hex, value 0

Buttons at the bottom: Submit Changes, Reset Changes, Print Media Sensor Profile.

Footer: Home: <https://www.zebra.com>  
Support: <https://www.zebra.com/support.html>

Table 17 • View and Modify Printer Settings Submenus (Continued)

Media Setup

**Media Setup**

**MEDIA TYPE**  
NON-CONTINUOUS

**SENSOR TYPE**  
WEB

**SENSOR METHOD**  
TRANSMISSIVE

**PRINT METHOD**  
DIRECT-THERMAL

**PRINT WIDTH**  
Range 2 to 832  
831

**MAXIMUM LENGTH**  
Range 203 to 7967  
3045

Submit Changes

Reset Changes

Home: <https://www.zebra.com>  
Support: <https://www.zebra.com/support.html>

Calibration

**Calibration**

**MEDIA POWER UP**  
NO MOTION

**HEAD CLOSE**  
LENGTH

**Web Sensor**  
Range 0 to 100  
36

**Media Sensor**  
Range 0 to 100  
85

**Ribbon Sensor**  
Range 0 to 100  
44

**Mark Sensor**  
Range 0 to 100  
27

**Mark Media Sensor**  
Range 0 to 100  
27

**Transmissive Gain**  
Range 0 to 255  
6

**Transmissive Base**  
Range 0 to 100  
31

**Transmissive LED**  
Range 0 to 100  
100

**Ribbon Gain**  
Range 0 to 255  
7

**Mark Gain**  
Range 0 to 255  
4

**Mark LED**  
Range 0 to 100  
100

Submit Changes

Reset Changes

Print Media Sensor Profile

Table 17 • View and Modify Printer Settings Submenus (Continued)

**ZPL Control**

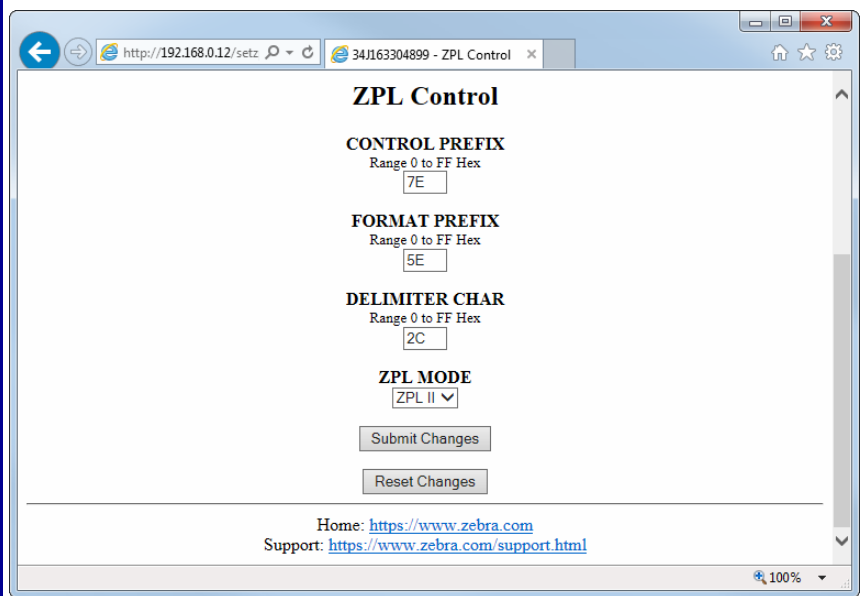

**Advanced Setup**

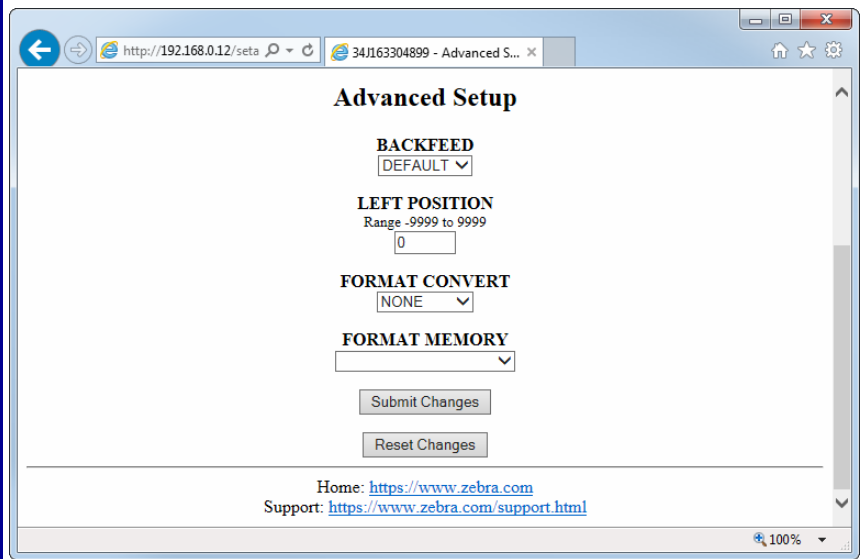

## Network Communications Screens

This section shows the screens that appear when you click on the menu items on the Network Communications menu.

### To access the Network Communications menu, complete these steps:

1. From the printer home page, click **View and Modify Printer Settings**.

The printer prompts you for a password.

2. Enter the password for your printer. The default password is **1234**.

3. Click **Submit Changes**.

The following statement appears:

**Access Granted. This IP Address now has admin access to the restricted printer pages. Please Click here to proceed**

4. Click on the statement.

The View and Modify Printer Settings page displays.

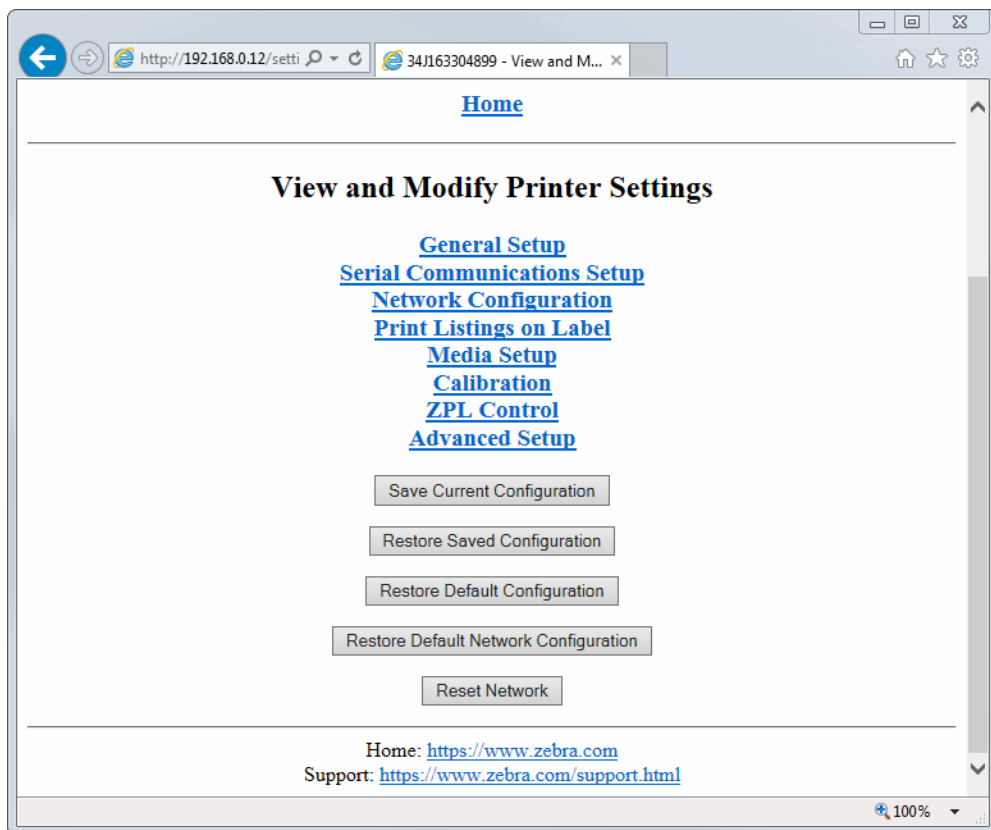

5. Click **Network Communications Setup**.

The Network Configuration Menu displays. [Table 18](#) shows the screens that appear when you click on the menu selections on this page and describes some of the items that may need clarification.

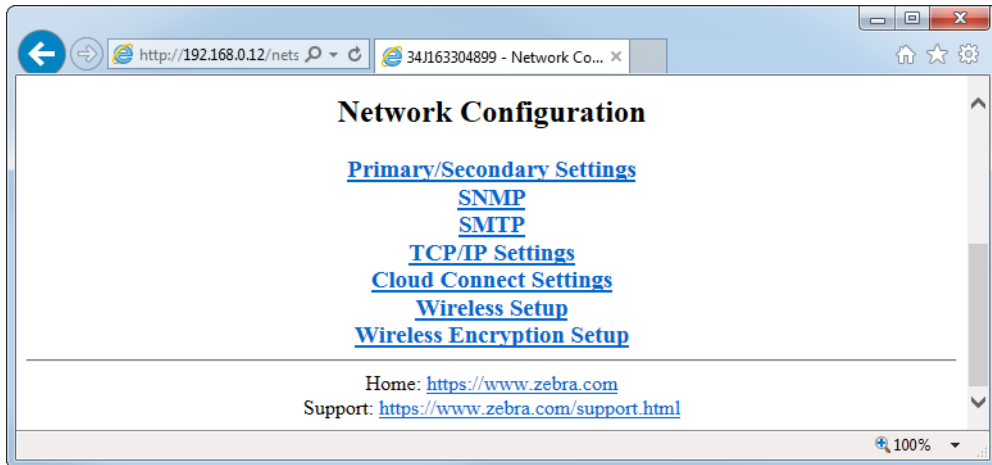



**Note** • What appears on your screen will be based on your printer model and the available connections.

**Table 18 • Network Configuration Submenus**

**Primary/Secondary Settings**

**V80.20.x**

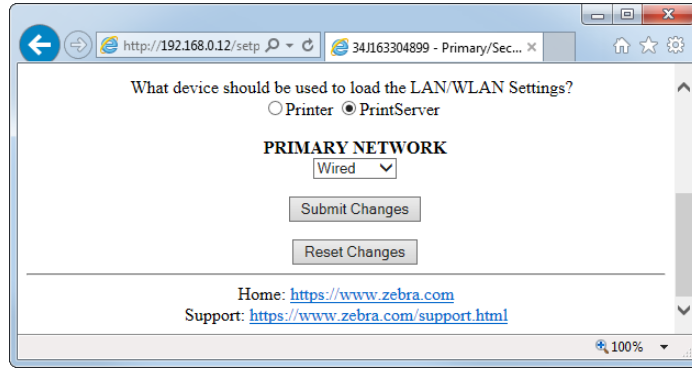

**X60.15.x**

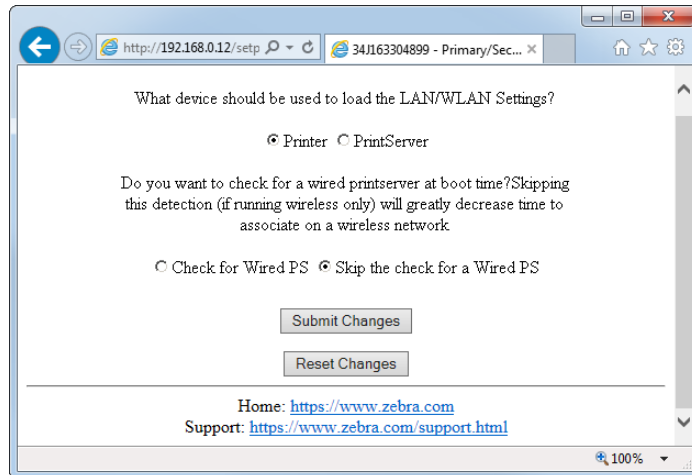

**Xi4, R110Xi4, ZM400, ZM600, RZ400, RZ600, ZE500, and 105SLPlus**

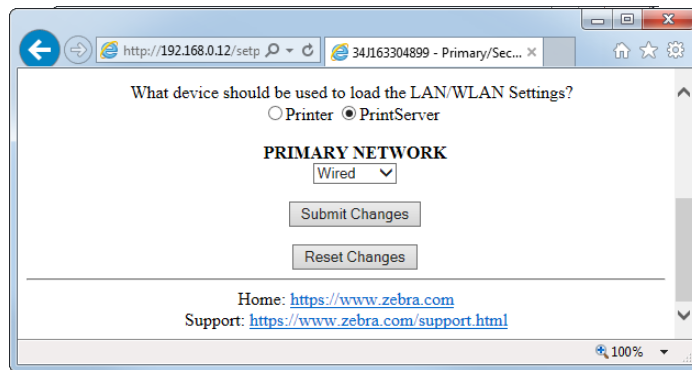



Table 18 • Network Configuration Submenus (Continued)

SNMP

The screenshot shows a web browser window with the URL <http://192.168.0.12/sets> and the page title '34J163304899 - SNMP'. The main content area is titled 'SNMP' and contains the following configuration fields:

- System Name:** 34J163304899
- System Contact:** (empty field)
- System Location:** (empty field)
- Get Community Name:** (password masked with asterisks)
- Set Community Name:** (password masked with asterisks)
- Trap Community Name:** (password masked with asterisks)

At the bottom of the form, there are two buttons: 'Submit Changes' and 'Reset Changes'. Below the form, there are links for 'Home: <https://www.zebra.com>' and 'Support: <https://www.zebra.com/support.html>'. The browser's zoom level is set to 100%.

SMTP

The screenshot shows a web browser window with the URL <http://192.168.0.12/sets> and the page title '34J163304899 - SMTP'. The main content area is titled 'SMTP' and contains the following configuration fields:

- SMTP Server Address:** 000.000.000.000
- Print Server Domain:** ZBRPrintServer.com

At the bottom of the form, there is a 'Submit Changes' button. Below the form, there are links for 'Home: <https://www.zebra.com>' and 'Support: <https://www.zebra.com/support.html>'. The browser's zoom level is set to 100%.

Table 18 • Network Configuration Submenus (Continued)

TCP/IP

Setting	Wireless	Internal Wired
IP ADDRESS	000.000.000.000	192.168.000.012
IP PROTOCOL	ALL	ALL
SUBNET MASK	255.255.255.000	255.255.255.000
DEFAULT GATEWAY	000.000.000.000	192.168.000.254
WINS SERVER IP	000.000.000.000	000.000.000.000
TIMEOUT CHECKING	YES	YES
TIMEOUT VALUE	300	300
ARP INTERVAL	0	0
BASE RAW PORT	6101	6101
CLIENT ID ENABLED	OFF	OFF
CLIENT ID TYPE	MAC ADDRESS	MAC ADDRESS
CLIENT ID PREFIX		
CLIENT ID SUFFIX	000000000000	00074D20B700

Submit Changes  
Reset Changes

Home: <https://www.zebra.com>  
Support: <https://www.zebra.com/support.html>

Cloud Connect Settings  
(V80.20.x and later)

Weblink Visibility Agent  
ON

Submit Changes  
Reset Changes

Home: <https://www.zebra.com>  
Support: <https://www.zebra.com/support.html>

Table 18 • Network Configuration Submenus (Continued)

Wireless Setup

The screenshot shows a web browser window with the URL `http://192.168.0.12/setw`. The page title is "Wireless Setup". The configuration options are as follows:

- CARD INSERTED:** YES
- SIGNAL STRENGTH:** NOT ASSOCIATED
- CARD FIRMWARE:** 15.68.07.p62
- ESSID:** 125
- OPERATING MODE:** INFRASTRUCTURE
- POOR SIGNAL:** 0 (Range 0 to 99)
- PREAMBLE:** LONG
- ADHOC AUTO MODE:** OFF
- ADHOC CHANNEL:** 1
- PERMITTED CHANNELS:** 1,2,3,4,5,6,7,8,9,10,11,36,40,44,48,52,56,60,64,100,104,108,112,116,132,136,140,149,153,157,161,166
- ALLOWED BAND:** ALL
- USER CHANNEL LIST:** all
- ACTIVE CHANNELS:** 1,2,3,4,5,6,7,8,9,10,11,36,40,44,48,52,56,60,64,100,104,108,112,116,132,136,140,149,153,157,161,166
- ROAM INTERVAL:** 5
- ROAM SIGNAL:** 40
- PULSE ENABLED:** ON
- PULSE RATE:** 15 (Range 5 to 300)

Buttons at the bottom include "Submit Changes" and "Reset Changes". The browser zoom is set to 100%.

Table 18 • Network Configuration Submenus (Continued)

Wireless Encryption Setup

The screenshot shows a web browser window with the URL <http://192.168.0.12/sete>. The page title is "Wireless Encryption Setup". The form contains the following fields and controls:

- WLAN SECURITY**: A dropdown menu currently set to "NONE".
- WEP INDEX**: A dropdown menu currently set to "1".
- ENCRYPTION KEY STORAGE**: A dropdown menu currently set to "HEX".
- WEP TYPE**: A dropdown menu currently set to "OPEN".
- ENCRYPTION KEY 1**: A text input field with a masked password (\*\*\*\*\*).
- ENCRYPTION KEY 2**: A text input field with a masked password (\*\*\*\*\*).
- ENCRYPTION KEY 3**: A text input field with a masked password (\*\*\*\*\*).
- ENCRYPTION KEY 4**: A text input field with a masked password (\*\*\*\*\*).
- WLAN SECURITY USERNAME**: A text input field.
- WLAN SECURITY PASSWORD**: A text input field with a masked password (\*\*\*\*\*).
- WPA PSK**: A text input field with a masked password (\*\*\*\*\*).

At the bottom of the form, there are two buttons: "Submit Changes" and "Reset Changes".

Footer text: Home: <https://www.zebra.com>  
Support: <https://www.zebra.com/support.html>

## Directory Listing

The directory page provides a listing of all file system devices (B:, E:, R:, Z:). The size, name, and location of each stored object appears.

Buttons are available to perform file management operations on the objects. The file management operations include:

- Delete object — Not available for objects in read-only memory (Z:).
- Copy object to a new name and/or device — Not available for objects in read-only memory (Z:).
- Run a ZBI program — Available only if the object is a stored ZBI program. For details, see the *Programming Guide for ZPL II, ZBI 2, Set-Get-Do, Mirror, and WML*.

### To view the Directory Listing, complete these steps:

1. From the Printer Home Page, click **Directory Listing**.

The Directory Listing screen displays.

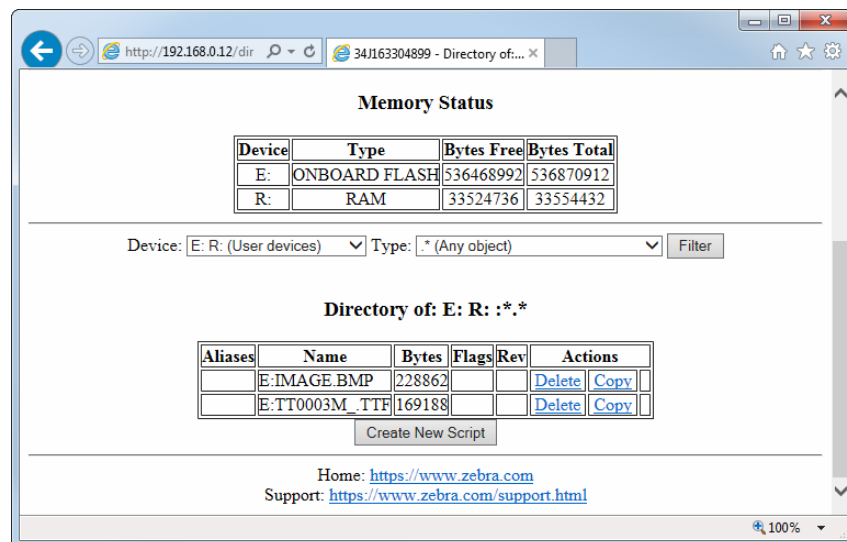

There are several fields to select in this view.

**To create a new item on the Directory Listing screen, complete these steps:**

1. From the Printer Home Page, click **Directory Listing**.

The Directory Listing screen displays.

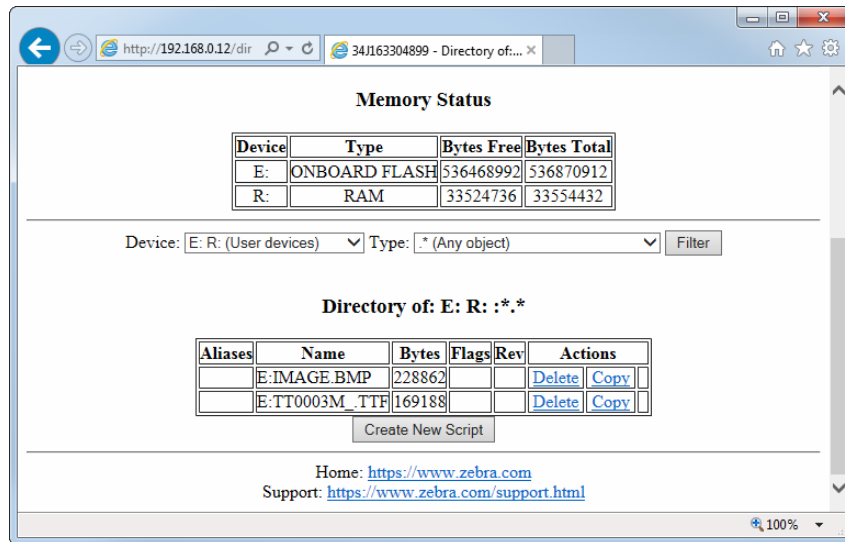

2. From the Directory Listing screen, click **Create New Script**.

The Create New Script screen displays.

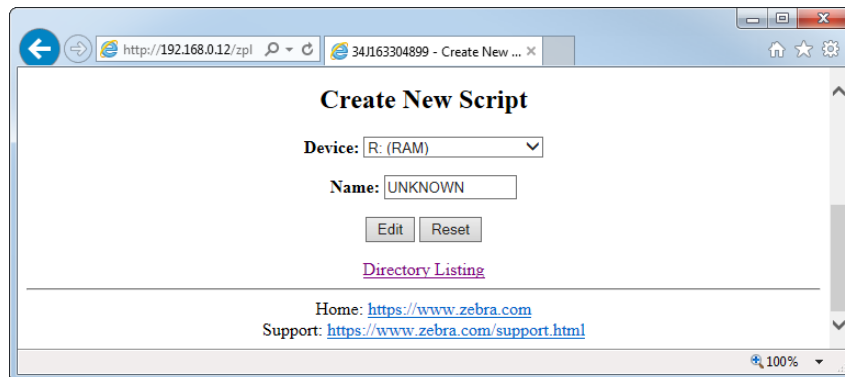

3. Select a device type from the drop-down menu to indicate a memory location that is appropriate to your needs.
  - **E: (ONBOARD FLASH)**—non-volatile memory, which is persistent across a power cycle.
  - **R: (RAM)**—volatile memory, which is not persistent across a power cycle.
  - **Z: (PRINTER INTERNAL MEMORY)**—non-volatile memory where the printer’s internal bar codes and fonts are stored. You can print a list of the bar codes and fonts through the printer’s control panel. Refer to the User Guide for your printer for instructions on listing the fonts and bar codes.
4. Type a name for the file in the Name field.

5. Click **Edit**.

The Edit ZPL Script screen displays.

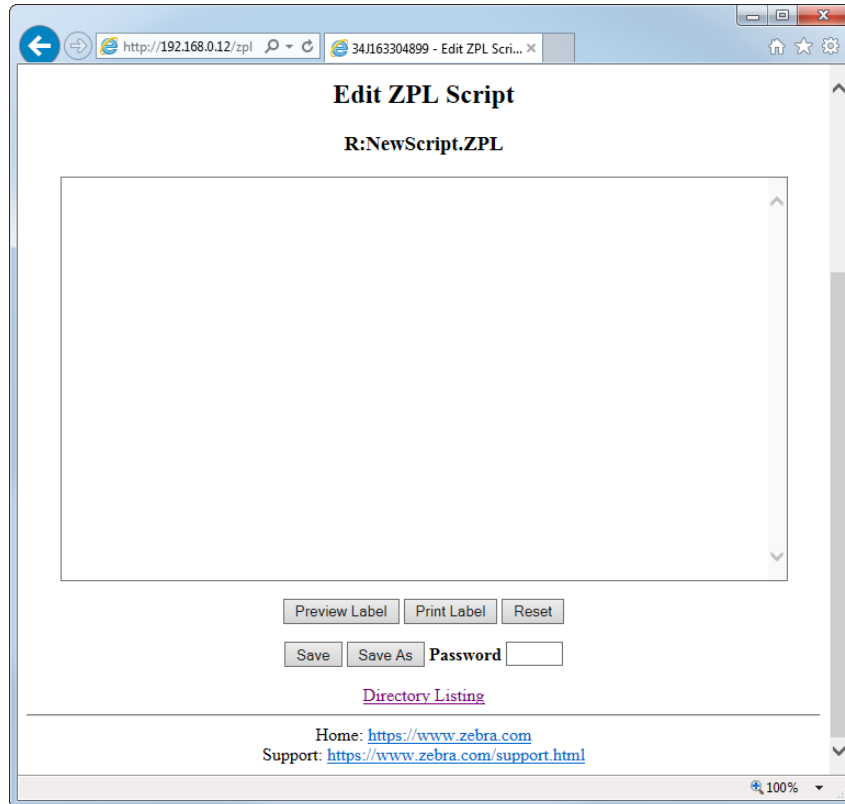

6. Enter the ZPL code in the text field.

7. Click one of the available buttons:

Button	Function/Operation
<b>Preview Label</b>	Displays a graphic representation of the label that results from the ZPL code.
<b>Print Label</b>	Sends the ZPL code to the printer.
<b>Reset</b>	Clears the text field.
<b>Save</b>	<p><b>a.</b> Enter the printer password in the password field.</p> <p><b>b.</b> Click <b>Save</b>.</p> <p>If the correct password was entered, saves the label to the ZPL file name entered on the Create New Script screen.</p>

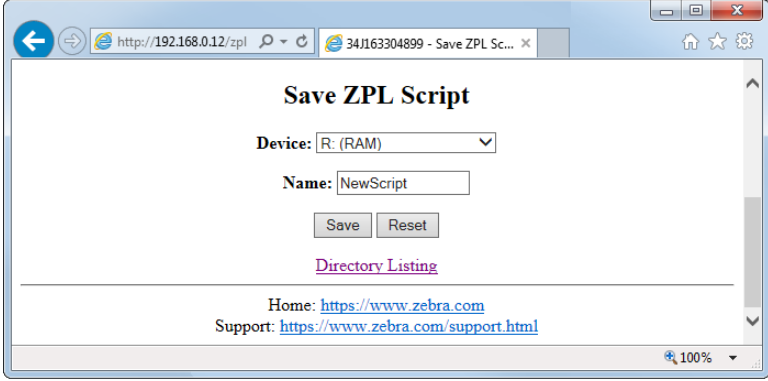
Button	Function/Operation
<b>Save As</b>	<p>a. Enter the printer password in the password field.</p> <p>b. Click <b>Save As</b>.</p> <p>The Save ZPL Script screen displays.</p>  <p>c. Enter a file name in the Name field.</p> <p>d. Click <b>Save</b>.</p> <p>If the correct password was entered on the Edit ZPL Script screen, the file is saved.</p>



## Printer Controls

This page offers control over basic printer functions.

Other functions are also accessible from this page. These include:

- Feed — causes printer to feed one label.
- Cancel One Format — cancels the currently printing format.
- Cancel All Formats — cancels all formats.
- Reset Printer — causes printer to perform its standard reset without cycling power.

### To view Printer Controls, complete these steps:

1. From the Printer Home Page, click Printer Controls.

The Printer Controls page opens.

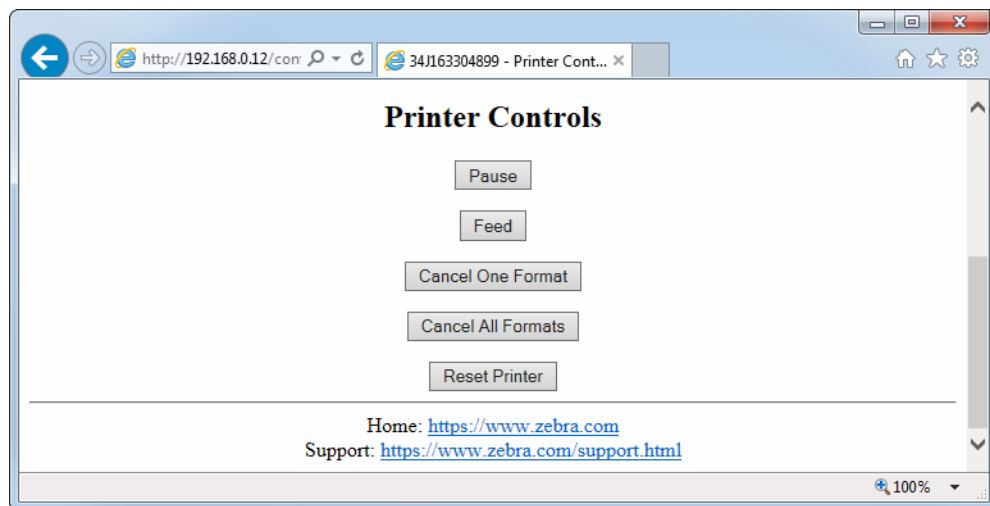

**Important** • In this view, you must have administrative rights to make changes to the printer controls. Some printers prompt for the password on this page.



**Notes •** \_\_\_\_\_

\_\_\_\_\_

\_\_\_\_\_

\_\_\_\_\_

\_\_\_\_\_

\_\_\_\_\_

\_\_\_\_\_

\_\_\_\_\_

\_\_\_\_\_

\_\_\_\_\_

\_\_\_\_\_

# Print Server Web Pages

This section provides details on the print server features that are available through the printer server web pages.

Some of the web pages in this section prompt you to enter the printer's default user ID and password (see [Default User ID and Password on page 33](#)).

## Contents

Status and Configuration . . . . .	100
Print Server Status . . . . .	107
View Port Status. . . . .	109
Reset . . . . .	110
Restore. . . . .	111

## Status and Configuration

The steps that follow are based on the navigation of a ZPL printer using firmware X.15 or above.



**Important** • You can upgrade your firmware by visiting our web site:  
<http://www.zebra.com/firmware>.

### To access the print server settings, complete these steps:

1. Open a Web browser.
2. In the Address text-box, type your printer's IP address, and press Enter.  
The Printer Home Page opens.

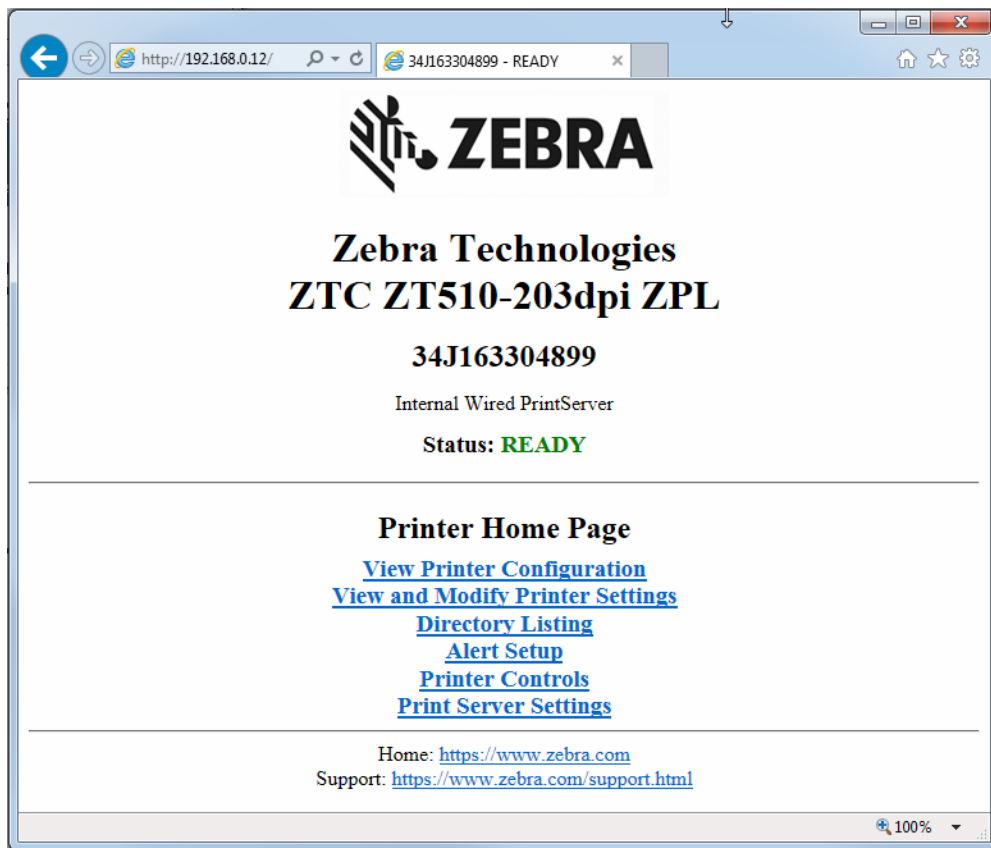

- From the Printer Home Page, click Print Server Settings.  
The Print Server Settings Page opens.

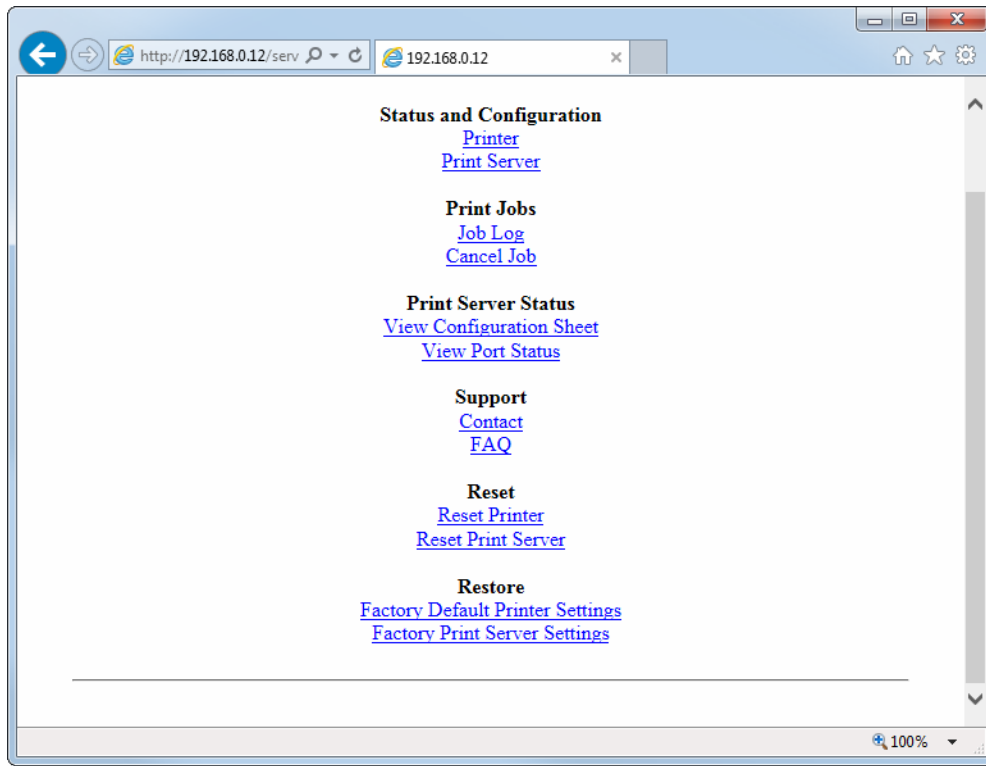

- From the Print Server Settings Page, click Print Server.  
The Print Server Configuration page opens.

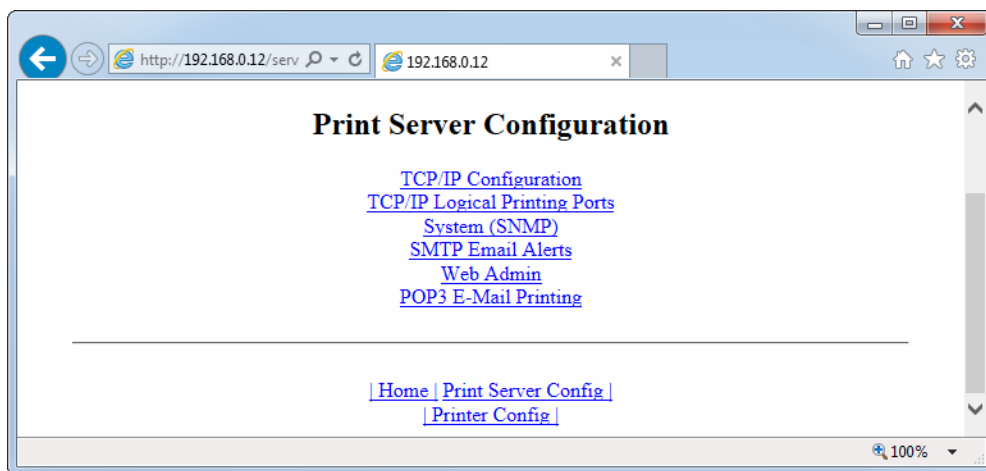

On the Print Server Configuration page, you have a menu to choose from (Table 19).



**Note** • What appears on your screen will be based on your printer model and the available connections.

**Table 19 • Print Server Configuration Submenus**

**Enabled Protocols**

Modifies the protocols to be used: NetWare, HP JetAdmin, or both.

Enabling Hewlett-Packard's HP JetAdmin Support allows the status from the Zebra device to display in HP JetAdmin utility.

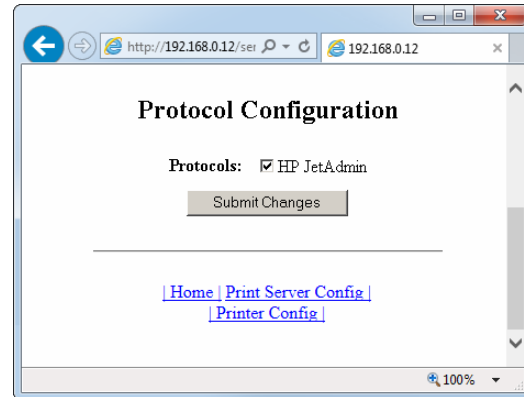

Table 19 • Print Server Configuration Submenus (Continued)

**TCP/IP Configuration**

You can change the TCP/IP configuration of the 10/100 Internal Print Server.

- **IP Address:** Use this feature to set the IP address if using the Permanent addressing method.
- **IP Protocol:** Use this feature to indicate if the user (permanent) or the server (dynamic) selects the print server's IP address. Choices include RARP, BOOTP, DHCP, Gleaning, and Permanent.
- **Subnet Mask:** Use this feature to set the subnet mask. The subnet mask must follow the format XXX.XXX.XXX.XXX, where each XXX is a number between 0 and 255.
- **Default Gateway:** Use this feature to set the default gateway. This gateway will be used whenever messages need to be sent to another network. This gateway address must follow the format XXX.XXX.XXX.XXX, where each XXX is a number between 0 and 255.
- **WINS Server IP Address:** Use this feature to set or view the IP address of the WINS Server.
- **Connection Timeout Checking:** Use this feature to enable or disable the Connection Timeout feature. The timeout is used to close network TCP/IP connections that are idle for more than the number of seconds entered in the Timeout Value.
- **Timeout Value (secs):** Use this feature to set the Connection Timeout Value. The Valid range is 10 to 3600 seconds. The default is 300 seconds.
- **ARP Broadcast Interval (mins):** Use this feature to set interval for sending an ARP Broadcast. The valid range is 1 to 30 minutes. Address Resolution Protocol (ARP) broadcast packets allow other network devices to associate the print server's IP Address with its hardware address.
- **Base Raw Port Number:** Use this feature to set the raw TCP port that the print server will use for printing tasks. The default is port 9100.

The screenshot shows a web browser window displaying the 'TCP/IP Configuration' page. The browser's address bar shows the URL 'http://192.168.0.12/ser' and the IP address '192.168.0.12'. The page title is 'TCP/IP Configuration'. The configuration fields are as follows:

- IP Address: 192.168.0.12
- IP Protocol: all
- Default Address Enabled:  Default Address
- Subnet Mask: 255.255.255.0
- Default Gateway: 192.168.0.254
- WINS Server IP Address: 0.0.0.0
- Connection Timeout Checking: on
- Timeout Value (secs): 300
- ARP Broadcast Interval (mins): 0
- Base Raw Port Number: 9100

A 'Submit Changes' button is located below the form fields. At the bottom of the page, there are navigation links: [Home](#), [Print Server Config](#), and [Printer Config](#). The browser's zoom level is set to 100%.

**Table 19 • Print Server Configuration Submenus (Continued)**

**TCP/IP Logical Printing Ports**

Logical printers allow you to set up multiple pre- and post-processing configurations for each output port. Each logical port configuration can perform the following:

- Add user-configured strings before and after the print data.
- Remove unwanted characters from the beginning of the print data.
- Four logical printer configurations are supported for each output port on the printer. The configurations can be assigned to any port, and all of these configurations can be assigned to a single output port.

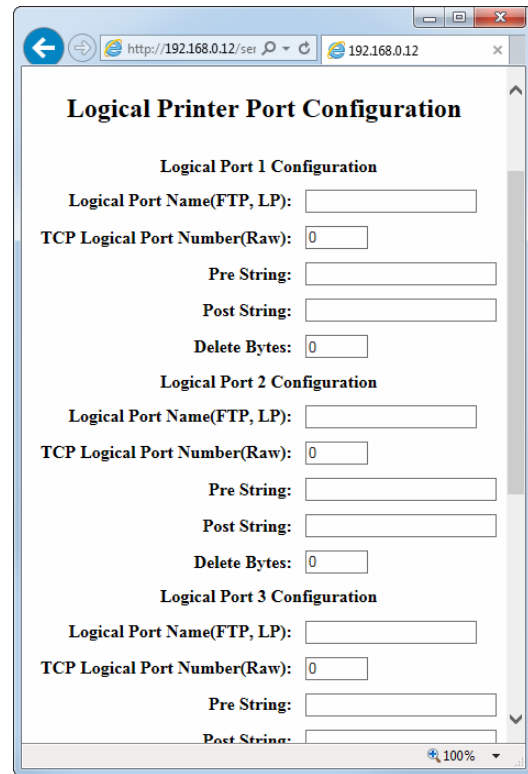

**System (SNMP)**

This feature gives you the ability to manage multiple devices on a network, be it printers, computers, or other network-attached devices.

On this page, you can define the SNMP system name, system location (10/100 Internal Print Server description), and other SNMP settings for your 10/100 Internal Print Server.

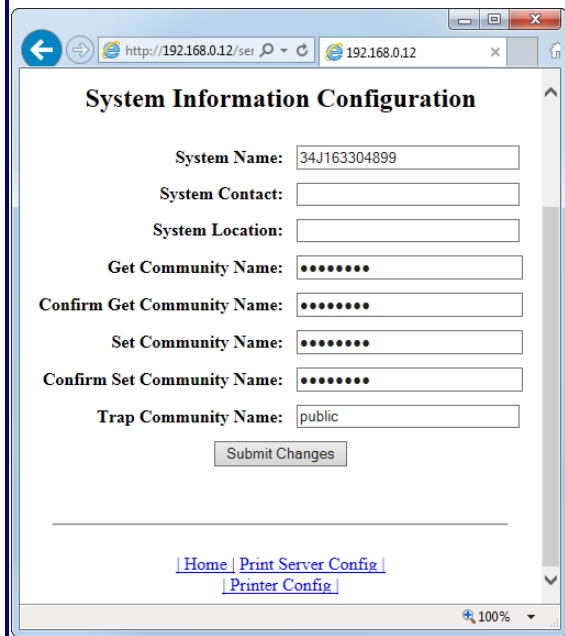



**Table 19 • Print Server Configuration Submenus (Continued)**

**SMTP Email Alert Configuration**

This feature allows you to enter data regarding System Information on the network that is being used. Typically, a Network Administrator would use this.



**Web Admin**

This page allows you to configure the Admin name and password. Links to upgrades and support information can also be altered.

**Note •** The printer and print server password can be changed on ZPL printers with firmware x.10 or higher.

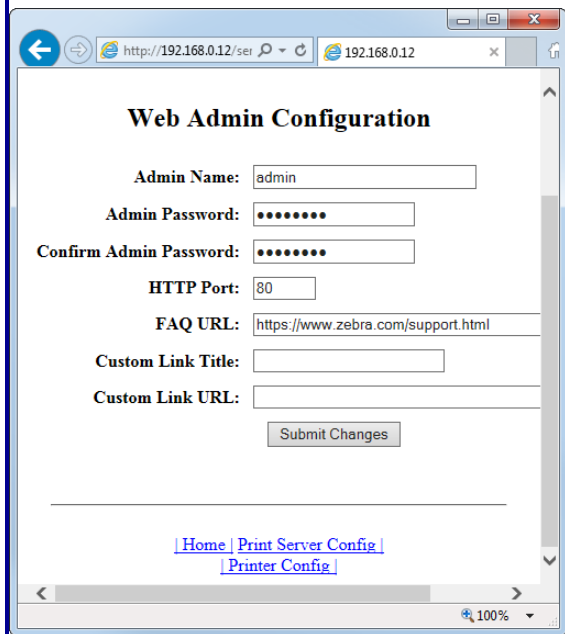

**POP3 Email Printing**

This feature helps you set up the print server to receive email messages containing formats that can be printed. The POP3 settings must be set to retrieve emails from the email server.

**Important •** Zebra recommends setting the POP3 polling interval no lower than 30. Some email servers will lock accounts after repeated login attempts.

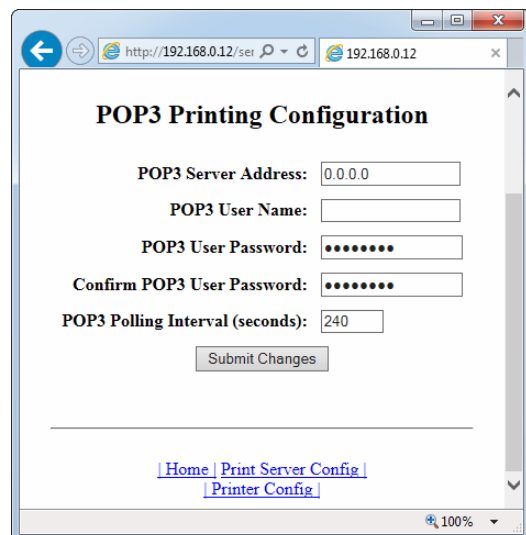

Table 19 • Print Server Configuration Submenus (Continued)

**Output Port Configuration**

(Not shown on example of Print Server Configuration screen because of printer model or options.)

This feature allows you to change the Parallel Port Mode setting. Selections for Parallel Port Mode include Compatibility, Nibble, Byte, and ECP.

- Compatibility is a unidirectional forward mode used only for sending data to the printer.
- Nibble, Byte, and ECP modes are all bidirectional modes. Data can be sent to and from the printer.
  - Nibble mode sends only 4 bits of data at a time in the reverse direction from the printer to the print server. When in nibble mode, communications from the print server to the printer are accomplished via compatibility mode.
  - Byte mode sends a full byte of data at a time in the reverse direction from the printer to the print server. When in byte mode, communications from the print server to the printer are accomplished via compatibility mode.
  - ECP mode is a complete forward and reverse mode that more efficiently transfers data.

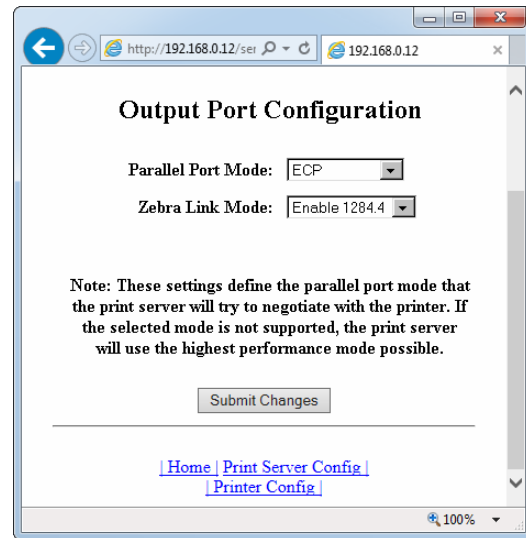

## Print Server Status

From the Print Server page in the Print Server Status section, you can access the print server configuration page and port status.

### To open the print server configuration page, complete this step:

1. From the Printer Home Page, click Print Server Settings.

The Print Server Settings page opens.

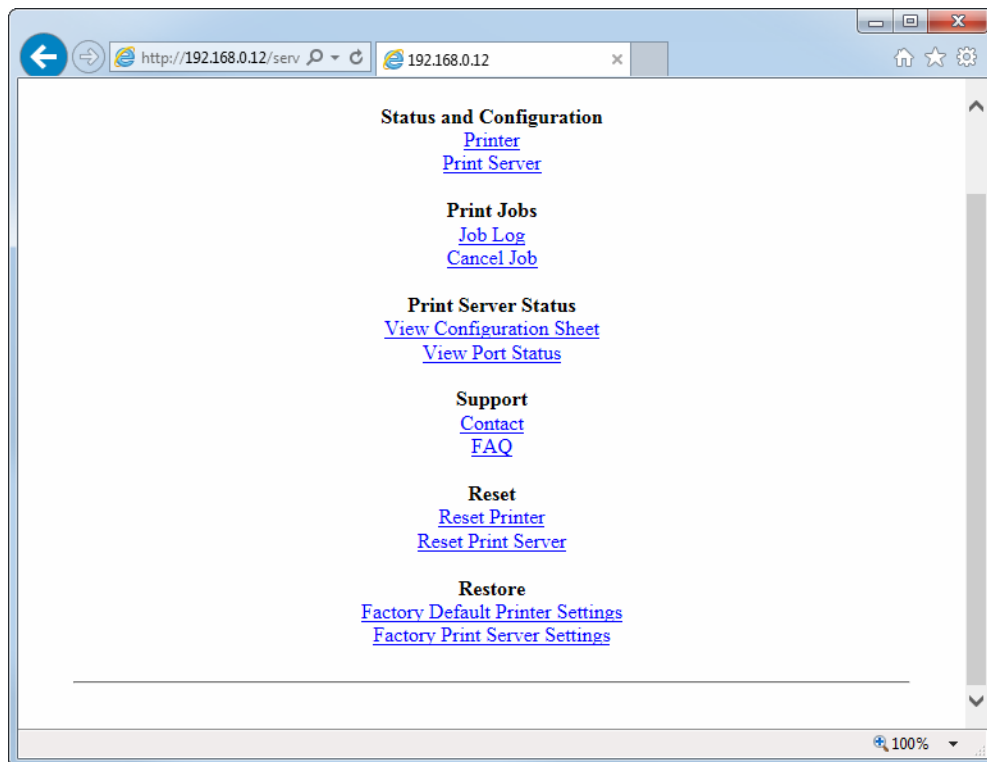

2. Click View Configuration Screen.

The Configuration Page opens.

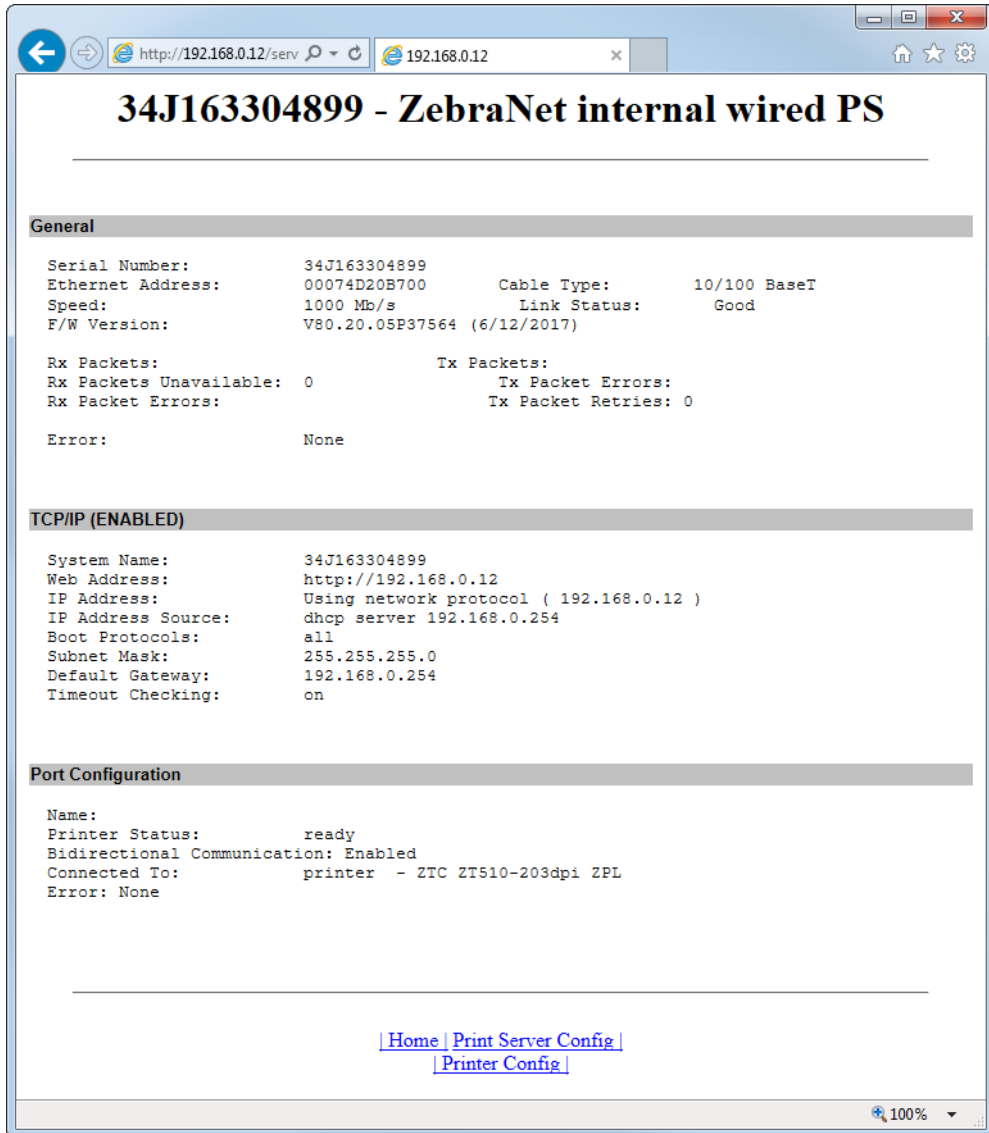

**34J163304899 - ZebraNet internal wired PS**

---

**General**

Serial Number: 34J163304899  
Ethernet Address: 00074D20B700 Cable Type: 10/100 BaseT  
Speed: 1000 Mb/s Link Status: Good  
F/W Version: V80.20.05P37564 (6/12/2017)

Rx Packets: Tx Packets:  
Rx Packets Unavailable: 0 Tx Packet Errors:  
Rx Packet Errors: Tx Packet Retries: 0

Error: None

---

**TCP/IP (ENABLED)**

System Name: 34J163304899  
Web Address: http://192.168.0.12  
IP Address: Using network protocol ( 192.168.0.12 )  
IP Address Source: dhcp server 192.168.0.254  
Boot Protocols: all  
Subnet Mask: 255.255.255.0  
Default Gateway: 192.168.0.254  
Timeout Checking: on

---

**Port Configuration**

Name:  
Printer Status: ready  
Bidirectional Communication: Enabled  
Connected To: printer - ZTC ZT510-203dpi ZPL  
Error: None

---

[Home](#) | [Print Server Config](#) |  
[Printer Config](#)

100%

## View Port Status



### To view the port status complete this step:

The default User ID and password are required to access this page.



**Important** • For specific information on the default User ID and/or default password, see [Default User ID and Password on page 33](#).

1. From the Print Server Settings page, click **View Port Status**.  
(Not shown on example of Print Server Configuration screen because of printer model or options.)

The Port Status page opens.

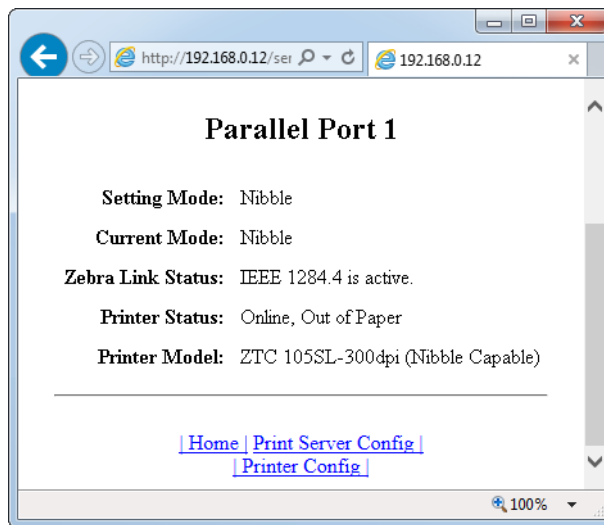

## Reset

From the Print Server page in the Reset section, you can reset the print server configuration settings to what they were before you made the most recent changes.

### To reset the print server, complete these steps:

1. From the Print Server Settings page, click Reset Print Server.  
The Reset Device page opens.

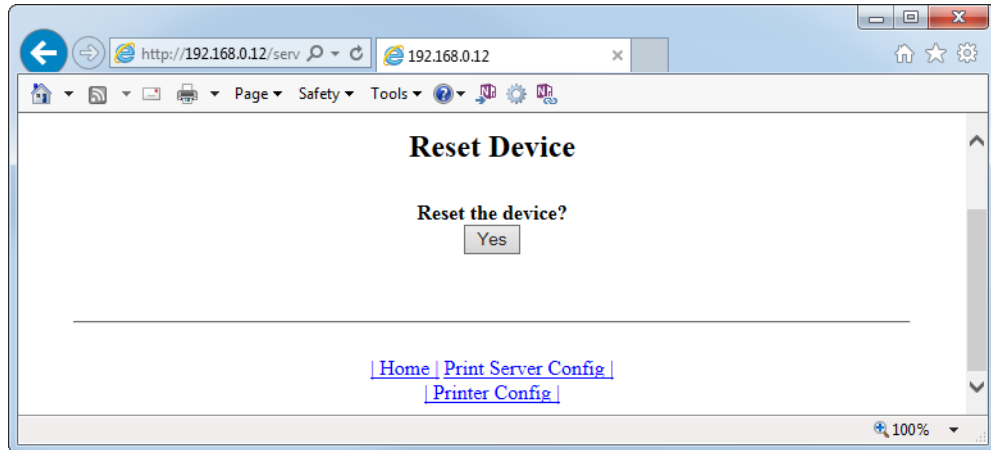

2. To reset the print server, click Yes.

## Restore

From the Print Server page, in the Restore section you can restore the print server to the default factory settings.

### To restore print server to the default factory settings, complete these steps:

1. From the Print Server page, click Factory Print Server Settings.  
The Restore Network Defaults page opens.

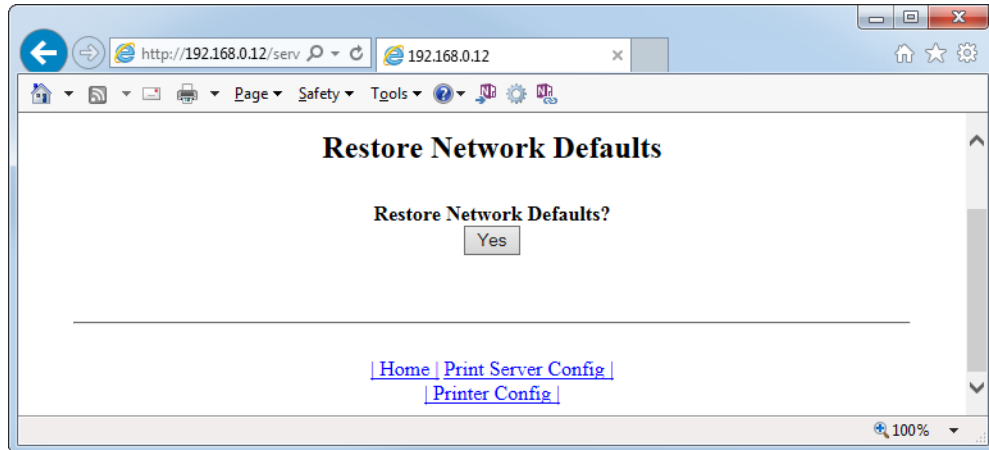

2. To restore the default values, click Yes.





# Control Panel

This section provides you with details on the Control Panel menu options.

## Contents

Control Panel Menu Options .....	114
Wired Network Parameters on the Printer Display .....	114
Wireless Network Parameters on the Printer Display .....	116

## Control Panel Menu Options

Control panel menu options only appear if a print server is installed. The control panel parameters are somewhat different for different printers. Refer to the user guide for your printer for specific instructions on how to modify the control panel parameters.



**Note** • The ZT210 and ZT220 printers have the same parameters available, but do not have control panels. Refer to the Zebra ZT210/ZT220/ZT230 User Guide for more information on how to access these parameters.

### Wired Network Parameters on the Printer Display

Table 20 identifies the wired network parameters available on various printers/print engines that have control panel displays and that have a print server installed.





**Note** • The ZT210 and ZT220 printers have the same parameters available, but do not have control panels. On these printers, these parameters can be viewed on the network configuration label (Figure 5 on page 38) and are controlled by ZPL and SGD commands.

**Table 20 • Wired Network Parameters**

105SL	PAX4	Xi4, 105SLPlus	ZM400/ZM600	ZE500	ZTxxx, ZD500R	LCD Option	Details
		✓	✓	✓		<b>LIST NETWORK</b>	Prints a network configuration label.
					✓	<b>PRINT INFORMATION</b>	
✓	✓					<b>WIRED PS CHECK?</b>	This tells if the printer searches for a wired print server at boot-up.
		✓	✓	✓	✓	<b>PRIMARY NETWORK</b>	This allows you to see if the printer is using an IP setting from the wireless or a wired print server at boot-up.
						<b>PRIMARY PRINT SERVER</b>	
✓	✓			✓		<b>LOAD LAN FROM?</b>	This determines if the printer uses IP settings from the printer or the print server at boot-up.
		✓	✓			<b>LOAD FROM EXT?</b>	
✓	✓	✓	✓	✓		<b>ACTIVE PRINTSRVR</b>	This allows you to see which print server is being used.
					✓	<b>ACTIVE PRINT SERVER</b>	
✓	✓	✓	✓	✓		<b>IP PROTOCOL</b>	The allows you to see if the user (permanent) or the server (dynamic) selects the IP address.
					✓	<b>WIRED IP PROTOCOL</b>	
✓	✓	✓	✓	✓		<b>IP ADDRESS</b>	This allows you to modify this setting when Permanent is select for IP PROTOCOL.
					✓	<b>WIRED IP ADDRESS</b>	

Table 20 • Wired Network Parameters

105SL	PAX4	Xi4, 105SL Plus	ZM400/ZM600	ZE500	ZTxxx, ZD500R	LCD Option	Details
✓	✓	✓	✓	✓		<b>SUBNET MASK</b>	This allows you to view the subnet mask.
					✓	<b>WIRED SUBNET MASK</b>	
✓	✓	✓	✓	✓		<b>DEFAULT GATEWAY</b>	This allows you to view the default gateway.
					✓	<b>WIRED GATEWAY</b>  The ZT230 printer displays: <b>GATEWAY</b>	
					✓	<b>WIRED MAC ADDRESS</b>  This parameter does not appear on the ZT230 printer.	This allows you to view the MAC address for the wired print server.
✓	✓	✓	✓	✓	✓	<b>RESET NETWORK</b>	This allows you to reinitialize the wireless radio card and any print servers (wired or wireless).
					✓	<b>IP PORT</b>	This allows you to view the currently selected TCP/IP port.
					✓	<b>IP ALTERNATE PORT</b>	This allows you to view the currently selected alternate TCP/IP port.

## Wireless Network Parameters on the Printer Display

Table 21 identifies the wireless network parameters available on various printers/print engines that have control panel displays and that have a print server installed.



**Note** • The ZT210 and ZT220 printers have the same parameters available, but do not have control panels. On these printers, these parameters can be viewed on the network configuration label (Figure 5 on page 38) and are controlled by ZPL and SGD commands.

Table 21 • Wireless Network Parameters





105SL	PAX4	Xi4, R110Xi4, 105SLPlus	ZM400/ZM600, RZ400/600	ZE500	ZTxxx, ZD500R	LCD Option	Details
✓	✓			✓		<b>WIRED PS CHECK?</b>	This tells if the printer searches for a wired print server at boot-up.
		✓	✓	✓	✓	<b>PRIMARY NETWORK</b>	This allows you to see if the printer is using an IP setting from the wireless or a wired print server at boot-up.
✓	✓			✓		<b>LOAD LAN FROM?</b>	This determines if the printer uses IP settings from the printer or the print server at boot-up.
		✓	✓			<b>LOAD FROM EXT?</b>	
✓	✓	✓	✓	✓		<b>ACTIVE PRINTSRVR</b>	This allows you to see which print server is being used.
					✓	<b>ACTIVE PRINT SERVER</b>	
✓	✓	✓	✓	✓		<b>IP PROTOCOL</b>	The allows you to see if the user (permanent) or the server (dynamic) selects the IP address.
					✓	<b>WLAN IP PROTOCOL</b>	
✓	✓	✓	✓	✓		<b>IP ADDRESS</b>	This allows you to modify this setting when Permanent is select for IP PROTOCOL.
					✓	<b>WLAN IP ADDRESS</b>	
✓	✓	✓	✓	✓		<b>SUBNET MASK</b>	This allows you to view the subnet mask.
					✓	<b>WLAN SUBNET MASK</b>	
✓	✓	✓	✓	✓		<b>DEFAULT GATEWAY</b>	This allows you to view the default gateway.
					✓	<b>WLAN GATEWAY</b>  The ZT230 printer displays: <b>GATEWAY</b>	

Table 21 • Wireless Network Parameters

105SL	PAX4	Xi4, R110Xi4, 105SLPlus	ZM400/ZM600, RZ400/600	ZE500	ZTxxx, ZD500R	LCD Option	Details
✓	✓	✓	✓	✓		<b>MAC ADDRESS</b>	This allows you to view the MAC address for the current wireless radio card.
					✓	<b>WLAN MAC ADDRESS</b>  The ZT230 printer displays: <b>MAC ADDRESS</b>	
✓	✓	✓	✓	✓	✓	<b>RESET NETWORK</b>	This allows you to reinitialize the wireless radio card and any print servers (wired or wireless).
✓	✓	✓	✓	✓	✓	<b>ESSID</b>	This allows you to view the ESSID value for your wireless network.
✓	✓	✓	✓	✓		<b>WLAN SECURITY</b>	This allows you to view the WLAN Security Type.
					✓	<b>CHANNEL</b>  This parameter does not appear on the ZT230 printer.	This allows you to view the wireless channel being used when the wireless network is active and authenticated.
					✓	<b>SIGNAL</b>  This parameter does not appear on the ZT230 printer.	This allows you to view the wireless signal strength when the wireless network is active and authenticated.
					✓	<b>IP PORT</b>	This allows you to view the currently selected TCP/IP port.
					✓	<b>IP ALTERNATE PORT</b>	This allows you to view the currently selected alternate TCP/IP port.
					✓	<b>VISIBILITY AGENT</b>  This parameter does not appear on the ZT230, ZT400 Series, or ZD500 Series printers.	This allows you to connect to Zebra's Asset Visibility Service via the Cloud-based Zebra Printer Connector using an encrypted, certificate-authenticated web socket connection.



**Notes •** \_\_\_\_\_

\_\_\_\_\_

\_\_\_\_\_

\_\_\_\_\_

\_\_\_\_\_

\_\_\_\_\_

\_\_\_\_\_

\_\_\_\_\_

\_\_\_\_\_

\_\_\_\_\_

\_\_\_\_\_

# Hardware Troubleshooting

This section provides you with solutions to known issues.

## Contents

Troubleshooting the External 10/100 Print Server . . . . .	120
Resetting to Factory Defaults . . . . .	120
External 10/100 Print Server Network Status and Status Indicators . . . . .	120
Troubleshooting the External 10/100 Print Server . . . . .	121
Troubleshooting the Internal Print Server . . . . .	123
Resetting the Internal Print Server to Factory Defaults . . . . .	123
Internal Print Server Network Status and Activity Indicators . . . . .	123
Troubleshooting the Wireless Print Server . . . . .	125
Resetting the Wireless Print Server to Factory Defaults . . . . .	125
ZebraNet Bridge Discovery or Configuration Problems . . . . .	126
Unable to Print . . . . .	126
Ping the Printer . . . . .	127
Telnet . . . . .	127
Unable to Configure Device . . . . .	128
HP JetAdmin or HP Web JetAdmin . . . . .	128
Wireless Error Messages . . . . .	128
General Wireless Issues . . . . .	129
Encryption and Authentication Issues . . . . .	131
IP Issues . . . . .	132



## Troubleshooting the External 10/100 Print Server

### Resetting to Factory Defaults



**Note** • You must have an active network cable connected to the external 10/100 Print Server device to default the device using the Test button.

See [Defaulting a 10/100 Print Server on page 63](#).

### External 10/100 Print Server Network Status and Status Indicators

Alongside of the RJ45 connector, there are two LED's containing a red element and a green element. By turning on and off different combinations of these two LED elements, the LED indicates Ethernet links, activity, and speed. For indicator locations, see [Figure 2, External 10/100 Print Server, on page 25](#).

Network Status LED State	Description
Off	No Ethernet link detected
Amber	10 Mbps link detected
Amber, blinking	10 Mbps link detected and Ethernet activity detected
Green	100 Mbps link detected
Green, blinking	100 Mbps link detected and Ethernet activity detected

Status LED State	Description
Green, solid	Print server is working.
Green, flashing	See <a href="#">Table 22 on page 121</a> .
Red, solid	
Red, flashing	
Alternating Red/Green	



## Troubleshooting the External 10/100 Print Server

**Table 22 • External 10/100 Print Server Issues and Solutions**

Issue	Possible Cause	Recommended Solution
<b>The Status LED is slowly flashing red</b>	The external 10/100 Print Server has not detected the presence of a network cable.	<ol style="list-style-type: none"> <li>1. Turn the printer off <b>(O)</b>.</li> <li>2. Remove the network cable from the external 10/100 Print Server.</li> <li>3. Plug the network cable back in until you hear a click.</li> <li>4. Check the other end of the cable in the same manner.</li> <li>5. Turn the printer on <b>(I)</b>.</li> </ol>
	A bad or wrong cable.  <b>Important</b> • Cables with a rating higher than CAT-6 have <b>not</b> been tested.	<ol style="list-style-type: none"> <li>1. Verify that the network cable is appropriate for the network and has an RJ-45 connector.</li> <li>2. Connect the external 10/100 Print Server to a network drop that is a known good network connection.</li> <li>3. If the external 10/100 Print Server is still unable to detect the network cable, contact Technical Support for assistance.</li> </ol>
	Power On Self-Test (POST) is in progress.	Wait for the printer to complete the POST.
<b>The Status LED is slowly flashing green (one time per second)</b>	The external 10/100 Print Server is trying to print a job.	If the job does not print, check the following: <ol style="list-style-type: none"> <li>1. Verify that the printer has media and ribbon (if in thermal transfer mode).</li> <li>2. If the printer is showing any errors, the external 10/100 Print Server cannot send data to the printer. The LED continues to blink until the printer malfunction is resolved or until the printer is turned off <b>(O)</b>.</li> </ol>

Table 22 • External 10/100 Print Server Issues and Solutions (Continued)

Issue	Possible Cause	Recommended Solution
<b>The Status LED is solid red for more than 30 seconds</b>	<p>The external 10/100 Print Server has failed the POST.</p> <p>A failed POST may be a connection to a malfunctioning external 10/100 Print Server device.</p>	<p>If the failure is not severe, the external 10/100 Print Server attempts to print a configuration label on the printer.</p> <ol style="list-style-type: none"> <li>1. Turn the printer off <b>(O)</b>, wait 10 seconds, then turn the printer on <b>(I)</b>.</li> <li>2. If the external 10/100 Print Server still fails the POST, the print server has a hardware problem that can only be fixed by replacing or returning the unit.</li> <li>3. Contact Repair for repair or replacement information.</li> </ol>
<b>The Status LED is alternately flashing red and green for longer than 2 minutes</b>	<p>The external 10/100 Print Server is in firmware-download mode. This means it is waiting for new firmware data to be sent before it continues normal functioning.</p>	<ul style="list-style-type: none"> <li>• If the external 10/100 Print Server was purposely put into firmware-download mode, finish the download with the proper update utility. Visit the Zebra Web site at <a href="http://www.zebra.com/utilities">http://www.zebra.com/utilities</a> to download this utility.</li> <li>• If the external 10/100 Print Server was not put into firmware-download mode or if you wish to exit this mode, default the unit. Follow the instructions in <i>Defaulting a 10/100 Print Server</i> on page 63.</li> </ul>



## Troubleshooting the Internal Print Server

### Resetting the Internal Print Server to Factory Defaults

Which model printer do you have?

If you have a...	Then...
ZM400 or ZM600 printer	Go to <a href="#">Defaulting the Print Servers on the ZM400 and ZM600 Printers</a> on page 64.
G-Series or LP/TLP 2824 Plus printer	Go to <a href="#">Defaulting the Print Servers on the LP/TLP 2824 Plus and G-Series Printers</a> on page 64.
HC100 printer	Go to <a href="#">Defaulting the Print Servers on the HC100 Printers</a> on page 64.
PAX4, Xi4, ZE500, or 105SLPlus printer/print engine	Go to <a href="#">Defaulting the Print Servers on 105SL, PAX4, Xi4, ZE500, and 105SLPlus Printers</a> on page 65.
ZD400, ZD500, or ZTxxx printer	Go to <a href="#">Defaulting the Print Servers on the ZD400, ZD500R, and ZTxxx Printers</a> on page 65.

### Internal Print Server Network Status and Activity Indicators

#### For the PAX4 Printers/Print Engines

Alongside of the RJ45 connector, there are two LED's containing a red element and a green element. By turning on and off different combinations of these two LED elements, the LED indicates Ethernet links, activity, and speed.

Network Status LED State	Description
Off	No Ethernet link detected
Amber	10 Mbps link detected
Amber, blinking	10 Mbps link detected and Ethernet activity detected
Green	100 Mbps link detected
Green, blinking	100 Mbps link detected and Ethernet activity detected

Status LED State	Description
Green, solid	Print server is working.
Green, flashing	See <a href="#">Table 22</a> on page 121.
Red, solid	
Red, flashing	
Alternating Red/Green	

### For the ZM400, ZM600, HC100, Xi4, and 105SL*Plus* Printers

Alongside of the RJ45 connector, there is a single LED containing a red element and a green element. By turning on and off different combinations of these two LED elements, the LED indicates Ethernet links, activity, and speed.

LED State	Description
Off	No Ethernet link detected
Amber	10 Mbps link detected
Amber, blinking	10 Mbps link detected and Ethernet activity detected
Green	100 Mbps link detected
Green, blinking	100 Mbps link detected and Ethernet activity detected

### For the G-Series and LP/TLP 2824 Plus Printers

On the top of the RJ45 connector, two LEDs are provided for these printers. The left LED is green and the right LED is amber. Follow the table below to determine activity and status of the G-Series and LP/TLP 2824 Plus printers.

Left LED State	Right LED State	Description
Off	Off	No Ethernet link detected
Off	Amber	10 Mbps link detected
Green, blinking	Amber	10 Mbps link detected and Ethernet activity detected
Green	Off	100 Mbps link detected
Green	Amber, blinking	100 Mbps link detected and Ethernet activity detected



## Troubleshooting the Wireless Print Server

### Print Server Will Not Operate on the 5Ghz Band

You may need to set your country code in order to enable the 5Ghz band.

- If you are using the wireless print server in the United States, Canada, or Japan, you will not need to set the country code. These countries have been pre-set at the factory.
- If you are operating the print server anywhere else in the world, you must set the country code to enable the 5GHz band. To set the country code, you must send a Set-Get-Do command to the printer. For specific command information, see the *Programming Guide for ZPL II, ZBI 2, Set-Get-Do, Mirror and WML*.

### Resetting the Wireless Print Server to Factory Defaults

You may need to restore the network parameters to the factory defaults under the following circumstances:

- If you download a different version of firmware to your printer
- If you need to reset the encryption keys (for instances where a key was entered incorrectly or was forgotten)

After you return the network parameters to the defaults, you must reconfigure your printer to use the wireless print server (see [Configuration of Wireless Securities on page 40](#)). If you saved the ZPL script generated by the Wireless Setup Wizard, simply send this file to the printer, and then power cycle the printer. If you were using a wireless password, you must set it again (use the `^WP` ZPL command or the `wlan.password SGD` command).

You can set the network parameters back to the factory defaults in two ways:

- Through the printer's web pages:
  - **Restore Default Network Configuration** (see [Defaulting ALL Print Servers on page 61](#)).
  - **Restore Factory Print Server Settings** (see [Restore on page 111](#)).
- Through the printer's display through the **RESET NETWORK** or **DEFAULT NET** option. Refer to the User Guide for your printer for specific instructions on how to access these items.



**Note** • The **LOAD DEFAULTS** option and the **Restore Default Configuration** button reset all printer parameters other than network settings back to factory defaults. The network settings will not change when these options are selected.

## ZebraNet Bridge Discovery or Configuration Problems

If you are having problems using ZebraNet Bridge to discover or configure the unit, check the following:

- Verify there is not a router between the workstation running ZebraNet Bridge and the print server. Because the print server does not have an IP address, TCP/IP communication cannot be started across a router. Run ZebraNet Bridge on the same subnet as the print server.
- Verify the wired print server has a solid green light. If the LED shows a rapidly flashing green light, check the network cable that is attached.
- Verify the wireless print server has authenticated to the access point. See [LCD Link Status and Wireless Signal Indicators \(Other Printers\)](#) on page 42 for more detailed information.

## Unable to Print

If you are having problems printing, verify that there is communication between the print server and the printer. Check the following:



- For the external 10/100 Print Server, print a configuration label by pressing the test button. If a configuration label does not print, verify the printer has media and ribbon (if used) and is not paused.
- For all print servers:
  - Ping the printer to determine the ability to communicate with the printer. See [Ping the Printer](#).
  - Or open a Telnet session and send a ZPL command to print a configuration label. See [Telnet on page 127](#) for more information.
  - Print a printer configuration label from the printer to verify that it can print (refer to the printer's User Guide for instructions). Check obvious error conditions such as head open, out of media, or out of ribbon.
  - If problems persist, contact Technical Support.

## Ping the Printer

### To ping the printer, complete these steps:

1. Open a DOS window by clicking Start > Run.
2. In the Open text box, type: cmd
3. From the DOS prompt, type:  
`ping xxx.xxx.xxx.xxx`  
where xxx.xxx.xxx.xxx is the IP address of the print server

You see a reply from the print server indicating a connection.

```
C:\>ping 172.30.1.34
Pinging 172.30.1.34 with 32 bytes of data:
Reply from 172.30.1.34: bytes=32 time=8ms TTL=126
Reply from 172.30.1.34: bytes=32 time=25ms TTL=127
Reply from 172.30.1.34: bytes=32 time=6ms TTL=127
Reply from 172.30.1.34: bytes=32 time=23ms TTL=127

Ping statistics for 172.30.1.34:
    Packets: Sent = 4, Received = 4, Lost = 0 (0% loss),
    Approximate round trip times in milli-seconds:
        Minimum = 6ms, Maximum = 25ms, Average = 15ms
```

If the issue is a communication problem, you would have received an error message.

## Telnet

Open a telnet session to send a ZPL command from a DOS prompt.



**Note** • You do not need to open a telnet session if you pinged the printer using the previous procedure. The purpose of these two procedures is to identify whether your PC can communicate with your printer.

### To print a configuration label by sending a ZPL II command, complete these steps:

1. Open a DOS window by clicking Start > Run.
2. In the Open text box, type: cmd
3. From the DOS prompt, type:  
`telnet xxx.xxx.xxx.xxx 9100`  
where xxx.xxx.xxx.xxx is the IP address of the print server.  
This will connect your PC to the print server through the parallel port of the printer.
4. Enter ~WC.  
This ZPL command will print a configuration label on your printer.
5. Click the **X** in the upper right-hand corner of the window to exit.

If the configuration label prints, the issue is not a communication problem between the printer, the print server, or the PC.

## Unable to Configure Device

To assign an IP address to a print server using ZebraNet Bridge, you must be on the same subnet. If ZebraNet Bridge has Multicast enabled, you may be able to view the print server on another subnet, but you will not be able to configure the device.

## HP JetAdmin or HP Web JetAdmin

The print server may be set up and managed using HP JetAdmin or HP Web JetAdmin products.



## Wireless Error Messages

The following table shows error messages that may appear on the control panel.

Table 23 •

Message	Description
<b>NO CARD INSERTED</b>	The wireless radio card is not inserted at all or is not fully seated.
<b>NOT ASSOCIATED</b>	The wireless radio card is present but cannot log on to the network.
<b>NOT AUTHENTICATED</b>	The wireless radio card is present and associated with the access point, but it has not been authenticated by the authentication server.
<b>RADIO WARNING POOR SIGNAL</b>	<p>The wireless signal strength has dropped below the poor signal threshold value, which is set through the Wireless Setup web page (see <a href="#">Wireless Setup on page 91</a>).</p> <p> <b>Note</b> • The poor signal setting affects when you see the <b>POOR SIGNAL</b> warning, but it does not affect whether your printer will be able to associate with your network at a low signal strength.</p>
<b>NO WLAN REGION CODE CALL ZEBRA TECH.</b>	WLAN card is not configured properly. Contact your Zebra reseller for assistance.
<b>WLAN COUNTRY CODE NOT SELECTED</b>	<p>The WLAN country code has not been configured.</p> <ol style="list-style-type: none"> <li>a. Use the Up and Down arrows to select the appropriate country code.</li> <li>b. Press <b>Set</b> to save the country code.</li> </ol>





## General Wireless Issues

Table 24 •

Issue	Possible Cause	Recommended Solution
<b>The printer acknowledges the wireless radio card and indicates a signal strength, but the printer does not appear to connect to the network.</b>	The combination of signal strength and signal quality at the printer may not be good enough to establish a connection to the network.	Move the printer or the access point to another location, or remove any obstructions between the two. A direct line of site between the printer and access point provides the best results. Refer to the third-party documentation for your access point for additional recommendations and limitations.
	The printer is associated with, but not authenticated with, your access point.	<ol style="list-style-type: none"> <li>1. Check your encryption settings.</li> <li>2. Verify that your MAC address is approved for the access point.</li> </ol>
<b>The printer does not acknowledge the wireless radio card.</b>	The card may not be inserted correctly.	Make sure that the wireless radio card is correctly seated in the wireless option card slot.
	Your printer may not be equipped with a wireless print server.	Contact your authorized Zebra representative for information about purchasing a wireless print server.
	The card may not be supported for use with the wireless print servers.	Make sure that you are using a compatible wireless radio card (see <i>Supported Wireless Radio Cards</i> on page 9).
<b>After a firmware upgrade, the printer will not connect to the network.</b>	Network settings need to be updated.	<ol style="list-style-type: none"> <li>1. Reset the printer's network settings to their defaults. Refer to <i>Defaulting ALL Print Servers</i> on page 61.</li> <li>2. Reconfigure your printer to use the wireless print server (see <i>Configuration of Wireless Securities</i> on page 40). If you saved the ZPL script generated by the ZebraNet Bridge Wireless Setup Wizard utility, simply send this file to the printer. If you were using a wireless password, you need to set it again (use the ^WP ZPL command or the wlan.password SGD command).</li> <li>3. Power cycle the printer for the settings to take effect.</li> </ol>

Table 24 •

Issue	Possible Cause	Recommended Solution
<b>My wireless connection is inconsistent. The signal strengths change back and forth between high and low numbers.</b>	An access point may be bad. The card appears to be switching affiliations between access points.	Check the access points on your WLAN, particularly the one closest to the printer.
	The wireless radio card is repeatedly associating with two or more access points because of varying signal strengths.	Check the access points on your WLAN to determine what is causing the signal strengths to vary.
<b>My “n” Print Server is not operating on the 5Ghz band.</b>	You have not set the region code and are located in a country other than: <ul style="list-style-type: none"> <li>• United States</li> <li>• Canada</li> <li>• Japan</li> </ul>	If you are operating outside of the three countries listed, you must send a specific Set-Get-Do command to set your country code. For specific command information, see the <i>Programming Guide for ZPL II, ZBI 2, Set-Get-Do, Mirror, and WML</i> .



## Encryption and Authentication Issues

Table 25 •

Issue	Possible Cause	Recommended Solution
<b>The entry field for WEP keys on the printer's web page does not display all 26 characters.</b>	The field accepts 26 characters, but they may not be able to display all at once because of your browser or system settings.	Use the left and right arrow keys on your keyboard to move the cursor in the WEP key field and reveal characters that may not display.
<b>I set WEP encryption keys using the ^WX ZPL command, and now my wireless print server does not function.</b>	The ZPL script that you sent to the printer may have been incorrect. The printer may be using the wrong encryption key or looking for one that is undefined.	Resend the ^WX command. Make sure that all of the required commas are in place in the command. A missing or extra comma in this command can prevent the printer from joining the wireless network.
<b>I set WEP encryption keys using the ^WE ZPL command, and now my wireless print server does not function.</b>	The ZPL script that you sent to the printer may have been incorrect. The printer may be using the wrong encryption key or looking for one that is undefined.	Use the ^WX command instead of ^WE.
	You enabled WEP and WPA encryption modes at the same time.	Before enabling a new security type, disable any mode used previously. Use the ^WX command instead of ^WE to ensure that only one security type is enabled at a time.
<b>I set WEP encryption keys using the wlan.wep.index Set/Get/Do command, and now my wireless print server does not function.</b>	The command that you sent to the printer may have specified the index number for an encryption key that is undefined.	Resend the wlan.wep.index command with the index number for a defined encryption key.
<b>WPA mode will not work.</b>	The wireless radio card contains an outdated version of firmware.	Flash the latest firmware to the wireless radio card. Contact the card manufacturer for details.
<b>Kerberos mode will not work.</b>	You are using a wireless radio card that does not support Kerberos. Kerberos is available only with Symbol Technologies Spectrum24 wireless radio cards.	Switch to a Symbol Technologies Spectrum24 wireless radio card.
<b>The printer will not connect to the WLAN.</b>	You are using a wireless radio card that does not support the security type being used on your WLAN.	Switch to a wireless radio card that supports your security type. Check <a href="#">Table 1 on page 11</a> , <a href="#">Table 2 on page 12</a> , or <a href="#">Table 3 on page 13</a> , for the security types supported by different wireless radio cards.

## IP Issues

Table 26 •

Issue	Possible Cause	Recommended Solution
<p><b>The printer shows IP address 192.168.254.254, which does not appear to work.</b></p>	<p>IP address 192.168.254.254 is a default address. The printer shows this address after it times out while trying to connect. The printer was likely set to an incorrect static IP address.</p>	<p>Enter a valid static IP address. OR Set IP Protocol to All.</p>
	<p>The DHCP server is not functioning, so a dynamic IP address is not being assigned. The printer timed out and shows the default IP address of 192.168.254.254.</p>	<p>Check the DHCP server.</p>
<p><b>On my control panel, the IP settings are missing or show all zeros (000.000.000.000).</b></p>	<p>Actual IP settings (IP Resolution, IP Address, Subnet Mask, and Default Gateway) will only appear when the printer is associated to and authenticated with the WLAN. Until the time that the printer recognizes the existence of a print server, these parameters will not show through the control panel. After the print server is recognized, all zeros will display until the printer obtains an IP address or defaults to address 192.168.254.254.</p>	<ol style="list-style-type: none"> <li>1. Allow more time for the printer to complete its connection and obtain an IP address.</li> <li>2. If the printer does not connect, check that there is an adequate signal between the printer and the access point. If necessary, move the printer or the access point to another location, or remove any obstructions between the two. A direct line of site between the printer and access point provides the best results. Refer to the third-party documentation for your access point for recommendations and limitations.</li> <li>3. Check the IP Protocol setting. If using a static setting, the value entered might not be valid.</li> </ol>
<p><b>The IP address for my wired print server does not bring up the printer home page.</b></p>	<p>If both a wired and wireless print server are installed on a printer at the same time and the wireless printer is the primary/active print server, the printer web pages can be accessed only through the wireless print server's IP address.</p>	<p>In your browser window, type in the IP address of the wireless print server.</p>

# Frequently Asked Questions

This section provides a group of frequently asked questions (FAQs) about Zebra's wired and wireless print servers.

## FAQs

**Can the print server option work on a computer network that is running both TCP/IP and IPX protocols simultaneously?** Yes. The print server runs all of its available protocols simultaneously. This means that the print server can run on mixed networks such as a network using Microsoft, and UNIX.



**Important** • The print servers do not support IPX, but they can function on networks that use protocols.

**Will the print server allow connectivity to anything other than a PC network?**

Yes. The print server allows connectivity to systems such as IBM's AS400, provided that it is configured using TCP/IP. Other network protocols can be used with third-party adapters that are converted to 10BASE-T or 100BASE-T.

**What if a print job makes it to the queue, but never leaves the queue? The label does not print.**

Issue	Possible Cause	Recommended Solution
<b>If a print job makes it to the queue, but never leaves the queue?</b>	Printer is not turned on	Confirm that the printer is turned on and receiving power.
	Printer is using a bad or wrong network cable.	Confirm that the network cable is plugged in and that you can ping the printer.
	There was a misconfiguration while creating the queue.	Verify the following: <ol style="list-style-type: none"> <li>1. Confirm that you use the print server's valid IP address.</li> <li>2. If you are using a UNIX or AS/400 host, there is an option for the remote queue name. There is only one valid response to use: PORTLF1.</li> <li>3. If Windows does not have an LPR installed, the above required option should be left blank.</li> </ol> See the documentation for other operating system specific queue creation.

**What are the minimum requirements to network a printer on a wired network?**

- Cat-5 network cable with 10BASE-T or 100BASE-T connectors
- Internal or external print server
- Hub or Switch
- If a hub or switch is NOT used, you need a cross-over cable.
- Workstation running a TCP stack with print services installed.

**What ports are open on any print server and related software?**

**TCP Ports:**

- 21 FTP
- 23 Telnet
- 80 HTTP Server
- 515 Printer port
- 631 IPP port
- 9100 Raw socket connection



**UDP Ports:**

- 161 SNMP broadcast from print server
- 162 SNMP trap on print server Alert
- 4201 discovery destination on print server
- (dynamic) SNMP get request from ZebraNet Bridge
- (dynamic) discovery broadcast from ZebraNet Bridge
- (dynamic) discovery broadcast from ZebraNet Bridge

**What is the default User ID and password for the print server?**

- The User ID is **admin** and the password is **1234**.

**What are my network connectivity options based on when using a print server?**

It depends on your environment, but the print server accepts print jobs in any of the following ways:

- *FTP* — ZPL/EPL files can be sent to the printer via a FTP client as standard ASCII files.
- *HTTP* — (ZebraLink-enabled printers *only*) Using the script option of the print server's homepage, you can type ZPL into a specified location of the Web browser and send it to the printer.
- *IPP* — Using third-party IPP clients, print jobs can be sent via the Internet.
- *LPR/LPD* — Sometimes referred to as queue based printing. LPR/LPD is the standard in network printing. Most TCP/IP operating systems are compatible with this option.
- *Raw socket connection* — You can connect to the printer directly via the network, bypassing *everything in-between*. This option is commonly used to integrate ZPL/EPL into existing programs, such as VB scripts.
- *POP3* — With proper configuration, you can place ZPL/EPL files into the body of an email, and it will print. The print server periodically checks this email box at the specified intervals and prints the body of the message. **IMPORTANT:** Attachments and subject lines are not supported.







# Glossary

**10BASE-T** A type of Ethernet that uses unshielded twisted pair cable.

**100BASE-T** A type of Ethernet that can transmit 100Mb of data per second with a twisted-pair cable.

**ARP** The standard TCP/IP method for determining the actual network address of a device based on its IP address.

**ASCII** A standard for the binary representation of characters.

**BOOTP** BOOTP (Bootstrap Protocol) is a protocol that lets a network user be automatically configured (receive an IP address) and have an operating system booted (initiated) without user involvement. The BootP server automatically configures the following information: IP address, gateway, subnet, system name, name server, and more from a pool of pre-determined addresses for a certain duration of time. BootP is the basis for a more advanced network manager protocol, the DHCP (Dynamic Host Configuration Protocol).

**broadcast** In a network, a situation when all destinations on the network receive a given packet.

**client** A workstation or PC in a client/server environment.

**community** For SNMP, a relationship between an agent and a set of SNMP managers that defines security characteristics. The community concept is a local one, defined at the agent. Each community is given a unique community name.

**current mode (parallel port)** A mode that the printer and print server negotiate.

**DHCP (Dynamic Host Configuration Protocol)** DHCP is an alternative to another network IP management protocol, Bootstrap Protocol (BOOTP). Like BOOTP, DHCP can configure an IP address, gateway, subnet, system name, and name server. When speaking about any print server, BOOTP, and DHCP configure the same options.

**delete bytes** This number is used to remove characters from the beginning of every job sent to the logical printer. The value for delete bytes can range from 0 to 255.

**dynamic** A dynamic configuration, as the name implies, means that it changes. BOOTP and DHCP offer time-based leases for the configurations they assign. Their changes depend on the time-based lease, and how often the printer itself is offline and online again. A dynamic configuration can include BOOTP or DHCP.

**Extensible Authentication Protocol over Flexible Authentication via Secure Tunneling (EAP-FAST)** Extensible Authentication Protocol-Flexible Authentication via Secure Tunneling (EAP-FAST) is a publicly accessible IEEE 802.1X EAP type developed by Cisco Systems. It is available as an IETF informational draft. Extensible Authentication Protocol-Flexible Authentication via Secure Tunneling (EAP-FAST) is a publicly accessible IEEE 802.1X EAP type developed by Cisco Systems. It is available as an IETF informational draft. Cisco developed EAP-FAST to support customers who cannot enforce a strong password policy and wish to deploy an 802.1X EAP type that does not require digital certificates, supports a variety of user and password database types, supports password expiration and change, and is flexible, easy to deploy, and easy to manage. For example, a customer using Cisco LEAP who cannot enforce a strong password policy and does not want to use certificates can migrate to EAP-FAST for protection from dictionary attacks.

**Extensible Authentication Protocol over Transport Layer Security (EAP-TLS)** Second generation Wi-Fi security. Current Wi-Fi security standards (802.1x) define the use of the TLS protocol encapsulated within the Extensible Authentication Protocol (EAP) as one of the strongest security mechanisms for Wi-Fi. Using EAP-TLS provides well-regarded, standards-based security between an access point and a Wi-Fi client. This is a Microsoft standard.

- A form of 802.1X (EAP) authentication
- Uses client and server certificates for mutual authentication (PKI)
- TLS 1.0 (Transport Layer Security) is based on Secure Socket Layer (SSL) 3.0

**Extensible Authentication Protocol over Tunneled Transport Layer Security (EAP-TTLS)** EAP-TTLS is an extension of EAP-TLS which provides for certificate-based, mutual authentication of the client and network. Unlike EAP-TLS, however, EAP-TTLS requires only server-side certificates, eliminating the need to configure certificates for each WLAN client. In addition, it supports legacy password protocols, so you can deploy it against your existing authentication system (such as tokens or Active Directories.) It securely tunnels client authentication within TLS records, ensuring that the user remains anonymous to eavesdroppers on the wireless link and the entire network to the RADIUS server.

**Ethernet** A widely used local area network system based on the IEEE 802.3 standard.

**firmware** Software routines that are stored in ROM (Read Only Memory). This is typically part of a device, such as a printer or any print server.

**FTP** File Transfer Protocol, a TCP/IP-related protocol for transferring files between devices on a network.

**Flash memory** A type of memory that allows read-and-write operations, but permanently stores data when the power is turned off. Useful for storing firmware because it can be easily updated by downloading new code.

**gateway** A device that converts one higher-level network protocol to a different higher level protocol.

**gleaning** A temporary, local configuration option. Gleaning lets you add the address of the device you want to configure to your local workstation's ARP table. This configuration is not permanent and is valid only from the workstation from which you entered the ARP information. After the information is entered into the workstation's ARP table, the user follows up with a Telnet session to enter the information permanently. Note: When using ZebraNet Bridge, a wired PS with an address of 0.0.0.0 can only be discovered through a local broadcast.

**IP** Internet Protocol, one of the main protocols of the TCP/IP protocol suite.

**IP address** A network address used by the TCP/IP protocol.

**IPP** Internet Printing Protocol. Allows you to associate a printer with a URL address that is used for printing over the Internet.

**JetAdmin** A Hewlett-Packard printer management program available for NetWare and TCP/IP.

**Kerberos** Network authentication protocol that uses the concept of a time-limited "ticket" for access to network resources. Kerberos uses key distribution and client/server authentication.

### **Lightweight Extensible Authentication Protocol**

**(LEAP or Lightweight EAP)** A non-standard Wireless Security protocol from Cisco. LEAP uses mutual authentication, meaning that both the user and the access point must be authenticated before access to the LAN is allowed. Mutual authentication can help protect wireless networks from rogue access points, man-in-the-middle attacks, sniffing attacks, and active attacks. Based on 802.1X EAP protocol.

**liquid crystal display (LCD)** The LCD is a back-lit display that provides the user with either operating status during normal operation or option menus when configuring the printer to a specific application.

**logical** Refers to conceptual rather than physical. For example, a computer might have a single physical connection to the network (an Ethernet adapter card), but could have logical connections to several other devices on the network.

**LPD** LPD stand for Line Printer Daemon; it is the part that receives and processes the request. A "daemon" is a server or agent.

**MAC Address** Media Access Control. Ethernet address that corresponds to the assigned IP address.

**name server** A workstation on a TCP/IP network that provides a list of all workstations on the network.

**node** A device connected to a network, such as a computer or print server.

**parallel port** A port on a device that sends information in groups of bits over multiple wires, one wire for each bit in a group.

**ping** A TCP/IP command that determines whether a device is accessible on the network.

**POP3** Post Office Protocol, the protocol used to retrieve email from the server.

**port** A physical connector, such as the parallel port, or a logical connection to a device.

**post-string** A string that is sent at the end of every job going to the logical printer. Maximum 64 characters long.

**pre-string** A string that is sent at the beginning of each job that goes to the logical printer. Max 64 characters long.

**print server** A device in a network that changes a network protocol into a printer protocol.

**protocol** A method of sending and receiving data between two or more workstations on a network, and ensuring that the data is received without errors.

**Protected Extensible Authentication Protocol (PEAP)** A draft standard for a common approach to wireless-network user authentication.

- A form of 802.1X authentication
- Currently an IETF draft (still subject to change)
- Performs mutual client/server authentication using transport layer security (TLS), but only requires a server certificate
- With no client certificate, configuration is easier than EAP-TLS

**RARP** Reverse Arp, a standard TCP/IP method of determining a device's IP address based on its Ethernet address.

**raw TCP port** A type of TCP port in which data is passed unmodified to the receiving node.

**RJ45** A type of modular jack connector similar to a telephone connector with up to eight wires. Used for 10BASE-T and 100BASE-T Ethernet connections and for serial port connections.

**serial port** On a printer or print server, a port that transfers data one bit at a time. Serial ports usually have either a 25-pin, 9-pin "D," or RJ-45 connector setting mode (parallel port).

A mode that the print server is set to for the highest level of parallel port communications.

**server** A device on a local area network that provides services to client computers on the network.

**SMTP** Simple Mail Transfer Protocol, a protocol used to send email messages over the Internet.

**SNMP** Simple Network Management Protocol, a protocol for monitoring and controlling devices on a network.

**spooling** In printing applications, spooling is the transfer of data to a temporary storage area on disk (the print queue) prior to printing. Spooling allows many jobs to be queued to a single printer.

**static** Refers to a static IP address. All information is provided by the network administrator.

**subnet mask** A TCP/IP method of dividing a network into several smaller subnetworks.

**TCP/IP** Transmission Control Protocol/Internet Protocol, the de facto standard for Internet communications that is widely used on local area networks.

**TCP Port** A method of accessing a TCP/IP service, where a device with a single IP address can have multiple TCP ports.

**Telnet** A TCP/IP protocol that allows two devices to communicate over a LAN.

**trap** An unsolicited message sent by an SNMP agent to an SNMP management station. It notifies the management station of some unusual event.

**UNIX** A general-purpose computer operating system used on many different kinds of computers.

**Wi-Fi Protected Access (WPA)** WPA is a security protocol for wireless local area networks (WLANs) that includes encryption and user authentication.

**Wireless Encryption Protocol (WEP)** WEP is a security protocol for wireless local area networks (WLANs) that secures data transmissions using 64-bit or 128-bit encryption.

**ZebraLink** Allows you to connect and control your bar code printers anywhere and anytime.

**ZPL II** Zebra Programming Language II is a powerful label-definition and printer-control language.



Notes • \_\_\_\_\_  
\_\_\_\_\_  
\_\_\_\_\_  
\_\_\_\_\_  
\_\_\_\_\_  
\_\_\_\_\_  
\_\_\_\_\_  
\_\_\_\_\_  
\_\_\_\_\_  
\_\_\_\_\_

# Index

## Numerics

000.000.000.000 IP address 132  
10/100 print server settings 100  
192.168.254.254 IP address 132

## A

access point issues 130  
active device selection 46  
active print server  
    IP address 45  
    selecting primary network device 46  
adaptor for compact flash card 29  
address administration protocols 8  
advanced setup printer web page 85  
alerts  
    set using WebView 53  
    set using ZebraNet Bridge 51  
    setting and monitoring 51  
    ZebraLink 51  
assign an IP address 48  
    from printer control panel (LCD) 48  
    from ZebraNet Bridge 48  
    using gleaning 50  
    using static route 49  
    via telnet 49  
    with DHCP 48  
authentication issues 131

## B

browser requirements 8  
BSD-Style print queue configuration 68

## C

calibration web page 84  
Cloud Connect settings 90  
compact flash card installation 29  
configuration label  
    external wired print server 34  
    network configuration label 36  
configuration of wireless securities 40  
configuration problems for ZebraNet Bridge 126  
configuration settings  
    check using WebView 56  
    check using ZebraNet Bridge 56  
configure wireless print server  
    through Network Setup Wizard 40  
    through Set/Get/Do (SGD) command 40  
    through ZPL command 40  
control panel  
    menu options 114  
    view wireless status 41  
create new item in directory listing 94

## D

default print servers to factory settings  
    using WebView 61  
    using ZebraNet Bridge 63  
default user ID and password 33  
default wired print server to factory settings  
    HC100 printers 64  
    Xi4 printers 65  
    ZM400 and ZM600 printers 64  
    ZT210, ZT220, ZT230 printers 65

- default wireless print server to factory settings
  - HC100 printers 64
  - Xi4 printers 65
  - ZM400 and ZM600 printers 64
  - ZT210, ZT220, ZT230 printers 65
- device type 94
- directory listing
  - to create new item 94
  - to view 93
- discovery problem for ZebraNet Bridge 126

## E

- enabled protocols
  - print server configuration menu 102
  - procedure for enabling 59
- encryption
  - troubleshooting 131
  - wireless encryption setup 92
- external 10/100 print server
  - illustration 25
  - install 26
  - specifications 19

## F

- FAQ's 133
- File Transfer Protocol (FTP) 73
- firmware
  - connection problems after upgrade 129
  - requirements for wired print servers 17
  - requirements for wireless print servers 18
  - upgrade 24
- flash memory 94

## G

- general setup screen 81
- gleaning
  - assigning an IP address during a Telnet session 50
  - IP Protocol options 103

## H

- home page 100
- HP JetAdmin 128
- HP Web JetAdmin 128

## I

- install
  - compact flash and adaptor in wireless radio card 29
  - external 10/100 print server 26
  - internal 10/100 internal print server 27
  - wireless print servers 27
  - wireless radio card 27
- Internet Printing Protocol (IPP) 72
- IP address
  - 192.168.254.254 showing 132
  - all zeroes (000.000.000.000) 132
  - assign using control panel 48
  - assign using ZebraNet Bridge 48
  - assign via telnet session 49
  - for wired and wireless print servers 45
  - troubleshooting issues 132

## L

- label width minimums
  - external wired print server 34
  - network configuration label 36
- liability 2
- link status indicator 42

## M

- media setup 84
- memory locations 94
- memory requirements 16

## N

- network communications setup
  - network configuration screens 86
  - primary/secondary settings 88
  - SMTP settings 89
  - SNMP settings 89
  - TCP/IP settings 90
  - WebView 82
  - wireless encryption setup settings 92
  - wireless setup settings 91
- network default restoration 111
- network parameters
  - wired 114
  - wireless 116
- network status/activity indicator
  - external 10/100 print server 120
  - internal print server 123
- NO CARD INSERTED message 128
- noise level indicator 42
- NOT ASSOCIATED message 128
- NOT AUTHENTICATED message 128



**O**

- onboard flash 94
- output port configuration web page 106

**P**

- parallel port configuration 106
- password 33
- ping the printer 127
- poor signal strength 128
- POP3 email printing 105
- primary network device 46
- primary/secondary settings 88
- print listing on label 82
- print queue configuration
  - Berkeley Software Distribution (BSD)-Style 68
- print server
  - reset 110
  - restore 111
  - status and configuration 100
  - to view port status 109
- print server configuration menu
  - enabled protocols 102
  - output port configuration 106
  - POP3 email printing 105
  - SMTP email alert configuration 105
  - SNMP settings 104
  - TCP/IP configuration 103
  - TCP/IP logical printing ports 104
  - web admin settings 105
- print server configuration settings
  - to check 56
- print server status page 107
- printer configuration
  - to view settings 78
  - WebView 78
- printer controls
  - view 97
  - WebView 97
- printer home page 100
- printer memory 94
- printing issues 126
- protocols
  - enabling 59
  - print server configuration menu 102

**Q**

- queue configuration
  - BSD-Style 68
  - System V 69

**R**

- RADIO WARNING POOR SIGNAL message 128
- requirements
  - browser support 8
  - wired print server firmware 17
  - wired print server hardware 14
  - wireless print server firmware 18
  - wireless print server printer 15
- reset
  - external wired print server to factory defaults 120
  - internal wired print server to factory defaults 123
  - print server 110
  - wireless print server to factory defaults 125
- restore network defaults 111
- restore print server to default settings 111
- RFID setup 83

**S**

- security type on wireless radio cards 10
- serial communications setup 81
- set and monitor alerts
  - using WebView 53
  - using ZebraNet Bridge 51
- signal strength and quality indicators 42
- SMTP settings
  - network configuration menu 89
  - print server configuration menu 105
- SNMP settings
  - network configuration menu 89
  - print server configuration menu 104
- specifications
  - external 10/100 print server 19
  - internal 10/100 Print Server 20
  - wireless print server 21
- static route for assigning an IP address during a Telnet session 49
- supported wireless radio cards 9
- System V queue
  - configuration 69
  - prerequisite 69
  - UNIX configuration 69

**T**

- TCP/IP
  - configuration 103
  - logical printing ports 104
  - settings 90
- telnet 127

troubleshooting

- 000.000.000.000 as IP address 132
- connection problems after firmware upgrade 129
- encryption and authentication issues 131
- general wireless issues 129
- HP Web JetAdmin 128
- inconsistent wireless connection 130
- IP address 132
- IP issues 132
- Kerberos 131
- network status/activity indicator
  - external 10/100 print server 120
  - internal print server 123
- NO CARD INSERTED message 128
- no home page 132
- NOT ASSOCIATED message 128
- NOT AUTHENTICATED message 128
- not connecting to wireless network 129
- ping the printer 127
- poor signal strength 128
- print configuration label using ZPL command 127
- printer won't connect to WLAN 131
- RADIO WARNING POOR SIGNAL message 128
- reset print server to factory defaults
  - external wired 120
  - internal wired 123
  - wireless 125
- system disabled after encryption set 131
- unable to configure device 128
- unable to print 126
- using telnet 127
- WEP key field not large enough 131
- wireless error messages 128
- wireless print server 125
- wireless radio card not acknowledged 129
- WPA mode 131
- ZebraNet Bridge discovery or configuration 126

## U

- upgrade firmware 24
- user ID 33

## V

view

- directory listing 93
- port status of print server 109
- printer configuration 78
- printer controls 97

view and modify printer settings

- advanced setup 85
- calibration 84
- general setup 81
- media setup 84
- network communications setup 82
- print listings on label 82
- RFID setup 83
- serial communications setup 81
- WebView 80
- ZPL control 85

Visibility Agent 90

## W

web admin settings 105

WebView 76

- advanced setup 85
- calibration 84
- can't access web pages with wired IP address 132
- check configuration settings 56
- default print servers to factory settings 61
- directory listing 93
- enabled protocols 59
- general setup 81
- home page 76
- media setup 84
- network communications setup 82
- network configuration screens 86
- primary/secondary settings 88
- print listing on label 82
- print server status 107
- printer configuration 78
- printer controls 97
- reset print server 110
- restore network defaults 111
- RFID setup 83
- serial communications setup 81
- setting alerts 53
- SMTP settings 89
- SNMP settings 89
- TCP/IP settings 90
- view and modify printer settings 80
- view printer configuration settings 78
- view printer controls 97
- wireless encryption setup settings 92
- wireless setup settings 91
- ZPL control 85

wired print server

- check during bootup 46
- network parameters 114
- printer requirements 14
- supported services 8

- wireless error messages 128
- wireless link status indicator 42
- wireless print server
  - installation 27
  - network parameters 116
  - printer requirements 15
  - specifications 21
  - troubleshooting 125
  - troubleshooting (general issues) 129
  - wireless settings 91
- wireless radio card
  - install 27
  - install compact flash card and adaptor 29
  - printer not acknowledging 129
  - supported cards 9
  - supported security types 10
- wireless signal indicators 42
- wireless status indicator lights
  - HC100 43
  - ZT210, ZT220, ZT230 44
- wireless status on control panel 41

## Z

- ZebraLink alerts 51
- ZebraLink WebView 76
- ZebraNet Bridge
  - check configuration settings 56
  - default print servers to factory settings 63
  - device configuration issues 128
  - discovery or configuration problems 126
- ZPL control web page 85



**Corporate Headquarters**

Zebra Technologies Corporation  
3 Overlook Point  
Lincolnshire, IL 60069 USA  
T: +1 847 634 6700  
Toll-free +1 866 230 9494  
F: +1 847 913 8766

<http://www.zebra.com>