

x950 Series Switches

Advanced Layer 3+
AlliedWare Plus™ v5.5.1-0.1

x950-28XSQ Switch

x950-28XTQm Switch

x950-52XSQ Switch

x950-52XTQm Switch

XEM2-8XSTm Ethernet Line Card

XEM2-12XT Ethernet Line Card

XEM2-4QS Ethernet Line Card

XEM2-12XS Ethernet Line Card

XEM2-12XS v2 Ethernet Line Card

XEM2-4QS Ethernet Line Card

XEM2-1CQ Ethernet Line Card

PWR600 AC Power Supply

PWR600 DC Power Supply

FAN05 Fan Module

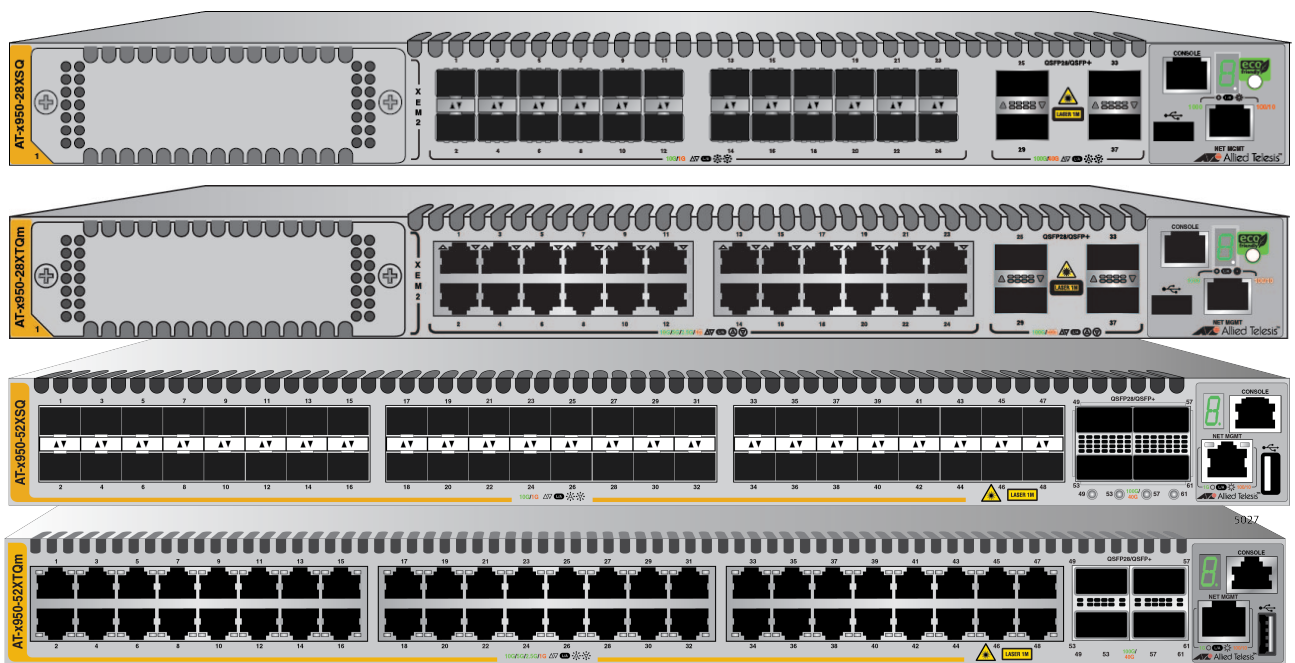

Installation Guide for Standalone Switches

Copyright © 2022 Allied Telesis, Inc.

All rights reserved. No part of this publication may be reproduced without prior written permission from Allied Telesis, Inc.

Allied Telesis, VCStack, and the Allied Telesis logo are trademarks of Allied Telesis, Incorporated. All other product names, company names, logos or other designations mentioned herein are trademarks or registered trademarks of their respective owners.

Allied Telesis, Inc. reserves the right to make changes in specifications and other information contained in this document without prior written notice. The information provided herein is subject to change without notice. In no event shall Allied Telesis, Inc. be liable for any incidental, special, indirect, or consequential damages whatsoever, including but not limited to lost profits, arising out of or related to this manual or the information contained herein, even if Allied Telesis, Inc. has been advised of, known, or should have known, the possibility of such damages.

Electrical Safety and Emissions Standards

This product meets the following standards.

U.S. Federal Communications Commission
<p>Radiated Energy</p> <p>Note: This equipment has been tested and found to comply with the limits for a Class A digital device pursuant to Part 15 of FCC Rules. These limits are designed to provide reasonable protection against harmful interference when the equipment is operated in a commercial environment. This equipment generates, uses, and can radiate radio frequency energy and, if not installed and used in accordance with this instruction manual, may cause harmful interference to radio communications. Operation of this equipment in a residential area is likely to cause harmful interference in which case the user will be required to correct the interference at his own expense.</p> <p>Note: Modifications or changes not expressly approved of by the manufacturer or the FCC, can void your right to operate this equipment.</p>

Industry Canada
<p>This Class A digital apparatus complies with Canadian ICES-003.</p> <p>Cet appareil numérique de la classe A est conforme à la norme NMB-003 du Canada.</p>

Warning: In a domestic environment this product may cause radio interference in which case the user may be required to take adequate measures.

EMI (Emissions)	FCC Class A CISPR 22 Class A EN55032 Class A VCCI Class A ICES-003 Class A RCM
EMC (Immunity)	EN 55024 EN 61000-3-2 EN 61000-3-3
Electrical Safety	UL 60950-1 (CULUS) EN 62368-1 (TUV) EN 60825-1 (TUV)
Laser Safety	EN 60825-1
RoHS	RoHS6

Translated Safety Statements

Important: Safety statements that have the  symbol are translated into multiple languages in the *Translated Safety Statements* document at www.alliedtelesis.com/documents/translated-safety-statements.

Remarque: Les consignes de sécurité portant le symbole  sont traduites dans plusieurs langues dans le document *Translated Safety Statements*, disponible à l'adresse www.alliedtelesis.com/documents/translated-safety-statements.

Contents

Preface	9
Document Conventions	10
Contacting Allied Telesis	11
Chapter 1: Overview	13
x950 Series Switches	14
Features	16
Hardware Features	16
XEM2 Ethernet Line Cards	17
Management Software and Interfaces	17
Management Methods	17
Management Panel	18
Power Supplies	18
Ports for 1Gbps SFP, 10Gbps SFP+, or SP10TM Transceivers.....	19
SFP and SFP+ Transceivers.....	19
LEDs	20
Twisted Pair Ports on the x950-28XTQm and x950-52XTQm Switches	21
Cable Requirements	21
LEDs	22
Ports for 40Gbps QSFP+ or 100Gbps QSFP28 Transceivers, or Breakout Cables	24
QSFP28 Transceivers	24
QSFP+ Transceivers.....	24
Breakout Cables.....	24
LEDs	25
Port Numbering for the x950-28XSQ and x950-28XTQm Switches.....	28
Port Numbering for the x950-52XSQ and x950-52XTQm Switches.....	29
Management Panel	30
USB Port	31
NET MGMT Ethernet Management Port.....	31
Console (RS-232) Port	32
Switch ID LED	32
eco-friendly Button	34
Optional Direct Attach Cables	35
PWR600 AC and DC Power Supplies	36
PWR600 AC Power Supply.....	37
LEDs	37
PWR600 DC Power Supply	39
LEDs	39
FAN05 Cooling Fan	41
Designating Ports in the Command Line Interface.....	42
Base Ports and Line Card Ports.....	43
Examples for the PORT Parameter on Base Ports	43
Examples for the PORT Parameter on an XEM2 Line Card	44
Software and Hardware Releases.....	45
Chapter 2: XEM2 Ethernet Line Cards	47
Overview	48
XEM2-8XSTm Line Card	51
Twisted Pair Ports	51
Twisted Pair Port LEDs	52

Transceiver Ports	53
Transceiver Port LEDs	54
XEM2-12XT Line Card	55
Twisted Pair Ports	55
LEDs.....	56
XEM2-12XTm Line Card.....	57
Twisted Pair Ports	57
LEDs.....	58
XEM2-12XS and XEM2-12XS v2 Line Cards.....	59
Transceiver Ports	59
Card Versions.....	60
LEDs.....	60
XEM2-4QS Line Card.....	62
Transceiver Ports	62
LEDs.....	63
XEM2-1CQ Line Card.....	64
Transceiver Port	64
LEDs.....	64
Chapter 3: Beginning the Installation	67
Reviewing Safety Precautions	68
Installation Options	73
Choosing a Site for the Chassis	74
Unpacking the Switch	75
Verifying the Accessory Kit.....	79
Unpacking the PWR600 AC Power Supply	81
Unpacking the PWR600 DC Power Supply.....	84
Chapter 4: Installing Power Supplies and Optional XEM2 Line Card	85
Installing PWR600 AC Power Supplies	86
Installing PWR600 DC Power Supplies.....	90
Connecting the Grounding Wire	93
Connecting the DC Power Wires.....	97
Installing an Optional XEM2 Ethernet Line Card	101
Chapter 5: Installing the Switch on a Table	105
Chapter 6: Installing the Switch in an Equipment Rack	109
Beginning the Installation	110
Required Items	110
Switch Orientations in the Equipment Rack	110
Removing the Bumper Feet.....	112
Installing the Switch.....	113
Chapter 7: Installing the Switch on a Wall	117
Switch Orientations on a Wall.....	118
Recommended Minimum Wall Area Dimensions	119
Plywood Base for a Wall with Wooden Studs.....	121
Installation Guidelines	123
Tools and Material	124
Installing the Plywood Base.....	125
Installing the Switch on the Plywood Base	126
Installing the Switch on a Concrete Wall	129
Chapter 8: Installing the Switch in the RKMT-SL01 Sliding Rack	133
Introduction.....	134
Rack Mount Kit Components	135
Adjustable Outer Rails.....	135
Inner Rails	135
Extension Brackets.....	135
Equipment Rack Requirements	137
Reviewing Safety Precautions	138
Installation Overview	141

Unpacking the Shipping Container	142
Installing the Outer Rails on the Equipment Rack	144
Installing the Extension Brackets on the Inner Rails	146
Measuring the Extension Bracket Lengths	146
Assembling the Extension Brackets	148
Installing the Inner Rails on the Switch.....	152
Installing the Switch in the Equipment Rack.....	154
Chapter 9: Verifying and Configuring the Switch	157
Powering On the Switch	158
Powering on the PWR600 AC Power Supply	158
Powering on the PWR600 DC Power Supply.....	160
Starting a Local Management Session.....	162
Verifying the Switch with AlliedWare Plus Commands	164
Disabling VCStack.....	165
Configuring Ports for 40Gbps QSFP+ or 100Gbps QSFP28 Transceivers, or Breakout Cables	168
Saving Your Changes and Rebooting the Switch.....	170
Chapter 10: Cabling the Networking Ports	171
Cabling Twisted Pair Ports	172
Guidelines to Handling Twisted Pair or Fiber Optic Transceivers	173
Installing Transceivers	174
Installing Direct Attach Cables.....	180
Chapter 11: Replacing Modules	183
Replacing XEM2 Ethernet Line Cards	184
Replacing PWR600 AC Power Supplies	189
Replacing PWR600 DC Power Supplies	194
Replacing FAN05 Modules	197
Removing Fan Modules	197
Installing Fan Modules	199
Chapter 12: Troubleshooting	203
Appendix A: Technical Specifications	209
Physical Specifications	210
Environmental Specifications	214
Power Specifications	215
Certifications.....	225
RJ-45 Twisted Pair Port Pinouts.....	226
RJ-45 Style Serial Console Port Pinouts	228

Preface

This guide contains the installation instructions for the x950 Series of advanced Layer 3 Ethernet switches. The instructions explain how to install the units as standalone switches. For instructions on how to build a stack of switches with the VCStack feature, refer to the *x950 Series Installation Guide for Virtual Chassis Stacking*.

This preface contains the following sections:

- ❑ “Document Conventions” on page 10
- ❑ “Contacting Allied Telesis” on page 11

Document Conventions

This document uses the following conventions:

Note

Notes provide additional information.



Caution

Cautions inform you that performing or omitting a specific action may result in equipment damage or loss of data.



Warning

Warnings inform you that performing or omitting a specific action may result in bodily injury.

Contacting Allied Telesis

If you need assistance with this product, you may contact Allied Telesis technical support by going to the Services & Support section of the Allied Telesis web site at **www.alliedtelesis.com/support**. You can find links for the following services on this page:

- ❑ Helpdesk (Support Portal) - Log onto Allied Telesis interactive support center to search for answers to your questions in our knowledge database, check support tickets, learn about Return Merchandise Authorizations (RMAs), and contact Allied Telesis technical experts.
- ❑ Software Downloads - Download the latest software releases for your product.
- ❑ Licensing - Register and obtain your License key to activate your product.
- ❑ Product Documents - View the most recent installation guides, user guides, software release notes, white papers and data sheets for your product.
- ❑ Warranty - View a list of products to see if Allied Telesis warranty applies to the product you purchased and register your warranty.
- ❑ Allied Telesis Helpdesk - Contact a support representative.

To contact a sales representative or find Allied Telesis office locations, go to **www.alliedtelesis.com/contact**.

Chapter 1

Overview

The chapter contains the following sections:

- ❑ “x950 Series Switches” on page 14
- ❑ “Features” on page 16
- ❑ “Ports for 1Gbps SFP, 10Gbps SFP+, or SP10TM Transceivers” on page 19
- ❑ “Twisted Pair Ports on the x950-28XTQm and x950-52XTQm Switches” on page 21
- ❑ “Ports for 40Gbps QSFP+ or 100Gbps QSFP28 Transceivers, or Breakout Cables” on page 24
- ❑ “Management Panel” on page 30
- ❑ “Optional Direct Attach Cables” on page 35
- ❑ “PWR600 AC and DC Power Supplies” on page 36
- ❑ “FAN05 Cooling Fan” on page 41
- ❑ “Designating Ports in the Command Line Interface” on page 42
- ❑ “Software and Hardware Releases” on page 45

x950 Series Switches

The x950 series switch is equipped with ports, card slot, and/or eco-Friendly button among others. Table 1 shows supported hardware components for each model.

Table 1. x950 Switch Components

	Port for SFP/SFP+ Transceiver	Twisted Pair Port	Port for 40/100Gbps Transceiver	Breakout Cable	XEM2 Line Card	eco-Friendly Button
x950-28XSQ	Ports 1 to 24	N/A	Ports 25, 29, 33, 37		Supported	Supported
x950-28XTQm	N/A	Ports 1 to 24	Ports 25, 29, 33, 37		Supported	Supported
x950-52XSQ	Ports 1 to 48	N/A	Ports 49, 53, 57, 61		N/A	N/A
x950-52XTQm	N/A	Ports 1 to 48	Ports 49, 53, 57, 61		N/A	N/A

Figure 1 shows the front panels of the x950-28XSQ and x950-28XTQm switches.

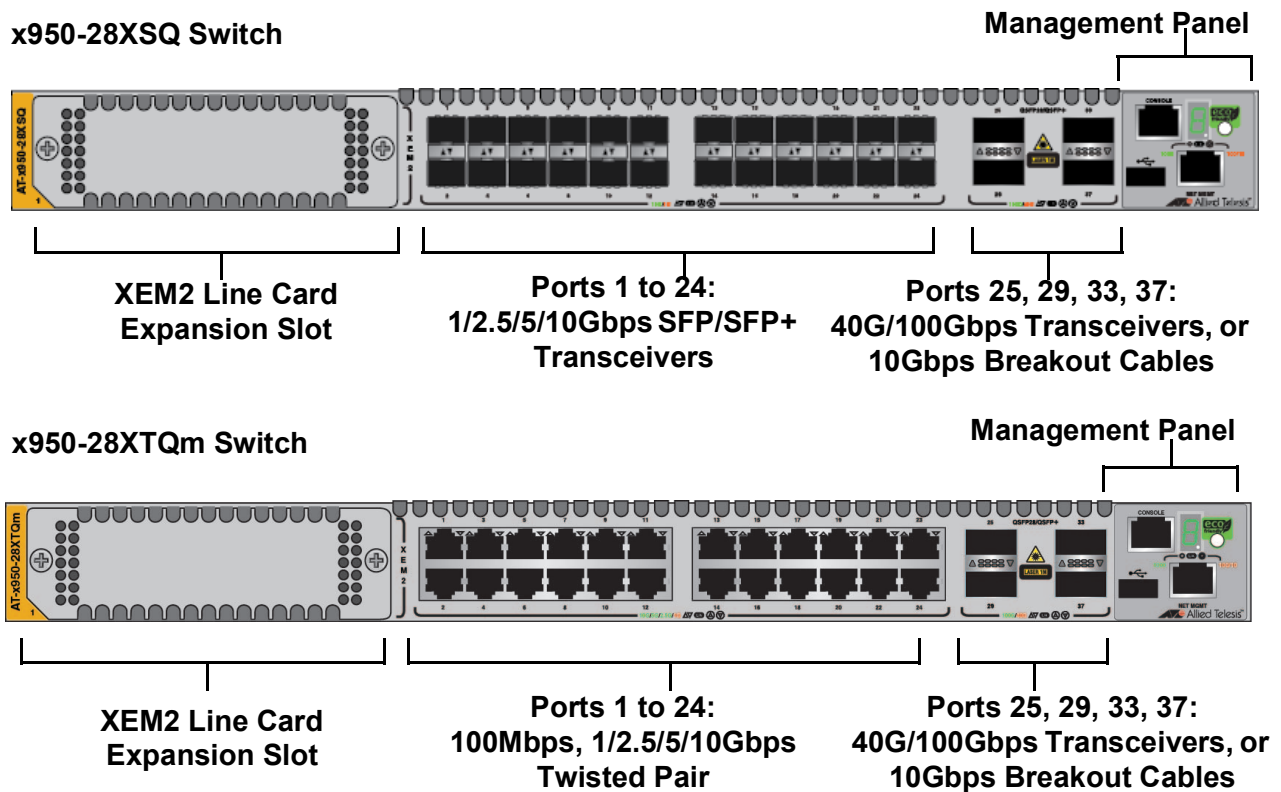
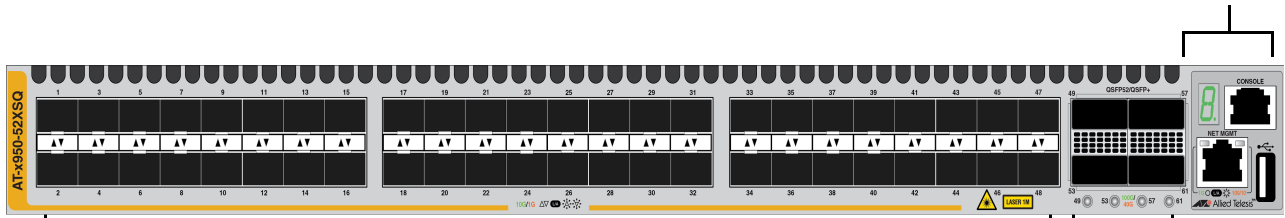

Figure 1. Front Panels of the x950-28XSQ and x950-28XTQm Switches

Figure 2 shows the front panels of the x950-52XSQ and x950-52XTQm switches.

x950-52XSQ Switch

Management Panel



Ports 1 to 48:
1/2.5/5/10Gbps SFP/SFP+ Transceivers

Ports 49, 53, 57, 61:
40G/100Gbps Transceivers, or 10Gbps Breakout Cables

x950-52XTQm Switch

Management Panel

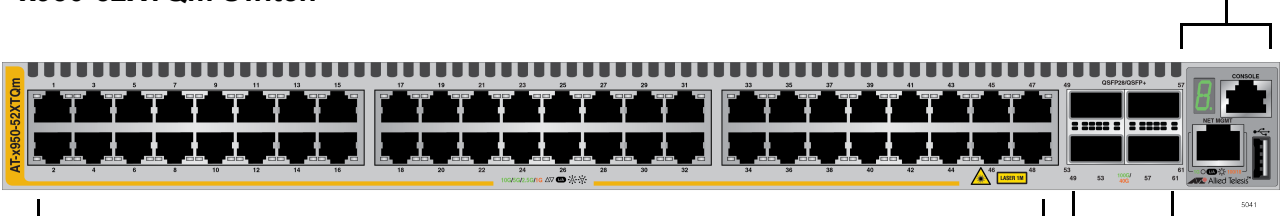

Ports 1 to 48:
100Mbps, 1/2.5/5/10Gbps Twisted Pair

Ports 49, 53, 57, 61:
40G/100Gbps Transceivers, or 10Gbps Breakout Cables

Figure 2. Front Panels of the x950-52XSQ and x950-52XTQm Switches

The rear panel of x950 series switches is shown in Figure 3.

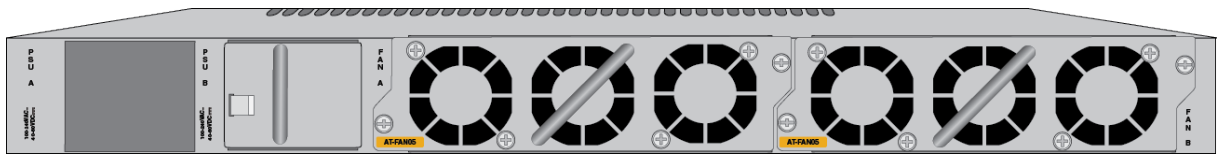

Two Slots for PWR600 Power Supply Modules

Two FAN05 Cooling Fan Modules

Figure 3. Rear Panel of the x950 Series Switches

Features

The main hardware features of the x950 Switches are listed here.

Hardware Features

The switch has the following hardware features:

- ❑ 1RU height
- ❑ 24 ports on the x950-28XSQ Switch for 1/2.5/5/10Gbps SFP/SFP+ transceivers. Refer to “Ports for 1Gbps SFP, 10Gbps SFP+, or SP10TM Transceivers” on page 19.
- ❑ 24 twisted pair ports on the x950-28XTQm Switch with speeds of 100Mbps and 1/2.5/5/10Gbps. Refer to “Twisted Pair Ports on the x950-28XTQm and x950-52XTQm Switches” on page 21.
- ❑ 48 ports on the x950-52XSQ Switch for 1/2.5/5/10Gbps SFP/SFP+ transceivers. Refer to “Ports for 1Gbps SFP, 10Gbps SFP+, or SP10TM Transceivers” on page 19.
- ❑ 48 twisted pair ports on the x950-52XTQm Switch with speeds of 100Mbps and 1/2.5/5/10Gbps. Refer to “Twisted Pair Ports on the x950-28XTQm and x950-52XTQm Switches” on page 21.
- ❑ Four ports for 40Gbps QSFP+ or 100Gbps QSFP28 transceivers, or 10Gbps breakout cables. Refer to “Ports for 40Gbps QSFP+ or 100Gbps QSFP28 Transceivers, or Breakout Cables” on page 24.
- ❑ One expansion slot on the x950-28XSQ and x950-28XTQm switches for an optional XEM2 Ethernet line card. Refer to Chapter 2, “XEM2 Ethernet Line Cards” on page 47.
- ❑ The switches support two power supplies for primary and redundant power. Refer to “PWR600 AC and DC Power Supplies” on page 36.
- ❑ The units comes with two pre-installed fan modules. Refer to “FAN05 Cooling Fan” on page 41.
- ❑ The switches come with brackets for standard 19-inch equipment racks or wall installation.
- ❑ The XEM2 Ethernet line cards, power supplies, and fan modules are hot-swappable.

XEM2 Ethernet Line Cards

The XEM2 Ethernet line cards are listed here:

- ❑ The XEM2 Ethernet line cards are for the x950-28XSQ and x950-28XTQm switches.
- ❑ XEM2-8XSTm Card features four 100Mbps and 1/2.5/5/10Gbps twisted pair ports with RJ-45 connectors and four ports for 1Gbps SFP or 10Gbps SFP+ transceivers. Refer to “XEM2-8XSTm Line Card” on page 51.
- ❑ XEM2-12XT Card features 12 twisted pair ports with speeds of 100Mbps and 1/10Gbps, and RJ-45 connectors. Refer to “XEM2-12XT Line Card” on page 55.
- ❑ XEM2-12XTm Card features 12 twisted pair ports with speeds of 100Mbps and 1/2.5/5/10Gbps, and RJ-45 connectors. Refer to “XEM2-12XTm Line Card” on page 57.
- ❑ XEM2-12XS and XEM2-12XS v2 Cards feature 12 ports for 1/2.5/5/10Gbps SFP/SFP+ transceivers. Refer to “XEM2-12XS and XEM2-12XS v2 Line Cards” on page 59.
- ❑ XEM2-4QS Card features four ports for 40Gbps QSFP+ transceivers. Refer to “XEM2-4QS Line Card” on page 62.
- ❑ XEM2-1CQ Card features one port for the 100Gbps QSFP28 transceiver. Refer to “XEM2-1CQ Line Card” on page 64.

Line cards are ordered separately. Refer to the product data sheet on the Allied Telesis web site for a list of approved transceivers.

Management Software and Interfaces

Here are the management software and interfaces:

- ❑ AlliedWare Plus management software.
- ❑ Command line interface, available locally through the Console port or remotely over the network.

The AlliedWare Plus management software comes pre-installed on the switch.

Management Methods

You can manage the switch as follows:

- ❑ Command line interface accessed locally through the Console port or remotely using Telnet or Secure Shell.
- ❑ Remote access with SNMPv1, v2c, or v3.

Management Panel

The management panel has the following features:

- ❑ Console RS-232 port for local management (no IP address required).
- ❑ USB 2.0 port for storing backup copies of system configuration files, updating management software, and other management functions.
- ❑ An eco-friendly button for turning off the port and system LEDs to reduce power consumption.

Note

The x950-52XSQ and x950-52XTQm switches do *not* have the eco-friendly button; however, the eco-friendly mode can be turned on or off with the ECOFRIENDLY LED or NO ECOFRIENDLY LED command in the Command Line Interface.

- ❑ Network management port for initial configuration and maintenance access to the chassis.

Power Supplies

The switch has slots for two power supplies on the back panel. The switch can be powered by a single power supply. Adding a second power supply provides power redundancy. Power supplies are ordered separately. Refer to “PWR600 AC and DC Power Supplies” on page 36.

Ports for 1Gbps SFP, 10Gbps SFP+, or SP10TM Transceivers

Ports 1 to 24 on the x950-28XSQ switch and ports 1 to 48 on the x950-52XSQ switch support 1Gbps SFP, 10Gbps SFP+ transceivers.

SFP and SFP+ Transceivers

Listed here are examples of 1Gbps SFP transceivers:

- ❑ SPSX and LR short and long distance transceivers using multi-mode or single mode fiber optic cable.
- ❑ SPTX transceiver series with RJ-45 connector for twisted pair cable.
- ❑ SPEX transceivers with a maximum distance of two kilometers with multi-mode fiber optic cable.

Listed here are examples of SFP+ 10Gbps transceivers:

- ❑ SP10SR, LR, ER and ZR series of short or long distance transceivers using multi-mode or single mode fiber optic cable.
- ❑ SP10TW series of direct attach cables in lengths up to seven meters.
- ❑ SP10BD series of bidirectional transceivers for single mode fiber optic cable with maximum distances of 10 to 40 kilometers
- ❑ SP10T transceiver with RJ-45 connector for links up to 20 meters at 10Gbps with Category 6a twisted pair cable, or 100 meters at 1Gbps.
- ❑ SP10LRM Long Reach Multimode transceiver for OM1 multi-mode fiber optic links up to 220 meters.
- ❑ SP10TM transceiver with RJ-45 connector for links up at 1/2.5/5/10Gbps.

Note

Industrial (-40 to 85° C) and extended (-40 to 105° C) temperature transceivers are available.

Here are transceiver guidelines:

- ❑ The ports do not support 100Mbps-FX transceivers.
- ❑ They support full-duplex mode only.
- ❑ You can set the port speeds with Auto-Negotiation or manually. The default is Auto-Negotiation.

Transceivers must be purchased separately. For a list of supported transceivers, refer to the product data sheet on the Allied Telesis web site.

LEDs The LEDs are located between the ports. Each port has one LED. Refer to Figure 4.

Top Transceiver Port LED **Bottom Transceiver Port LED**

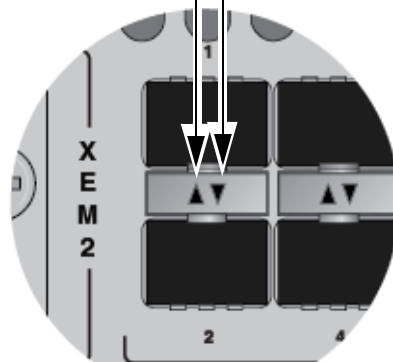

Figure 4. Link and Activity LEDs for Ports for 1Gbps SFP, 10Gbps SFP+, or SP10TM Transceivers

The LEDs display link and activity status. The possible LED states are described in Table 2.

Table 2. Link and Activity Status LEDs for 1Gbps SFP, 10Gbps SFP+, SP10TM Transceivers

State	Description
Solid Green	The transceiver has established a 10Gbps link to a network device.
Flashing Green	The transceiver is transmitting or receiving data in 10Gbps.
Solid Amber	The transceiver has established a 1Gbps link to a network device.
Flashing Amber	The transceiver is transmitting or receiving data in 1Gbps.
Off	<p>Possible causes of this state are listed here:</p> <ul style="list-style-type: none"> - The transceiver slot is empty. - The transceiver has not established a link to a network device. - The LEDs are turned off. To turn on the LEDs, use the eco-friendly button in the management panel or the NO ECOFRIENDLY LED command in the command line interface. <hr/> <p>Note The x950-52XSQ and x950-52XTQm switches do <i>not</i> have the eco-friendly button.</p> <hr/>

Twisted Pair Ports on the x950-28XTQm and x950-52XTQm Switches

The specifications for twisted pair ports 1 to 24 on the x950-28XTQm switch and ports 1 to 48 on the x950-52XTQm switch are listed in Table 3.

Table 3. Twisted Pair Ports on the x950-28XTQm and x950-52XTQm Switches

Specification	Description
Port Speed	<p>Here are the supported speeds:</p> <ul style="list-style-type: none"> - 100Mbps - 1/2.5/5/10Gbps <p>Here are the guidelines to setting port speeds:</p> <ul style="list-style-type: none"> - 100Mbps can be set manually or with Auto-Negotiation. - 1/2.5/5/10Gbps require Auto-Negotiation. <p>The default port setting is Auto-Negotiation.</p>
Duplex Mode	Full-duplex only
Maximum Distance	100 meters (328 feet)
Connector	8-pin RJ-45

Note

The network devices connected to the ports must be IEEE 802.3u compliant.

Cable Requirements

The minimum cable requirements are listed here:

- ❑ 100Mbps - Standard TIA/EIA 568-B-compliant Category 3 unshielded cabling.
- ❑ 1/2.5/5Gbps - Standard TIA/EIA 568-A-compliant Category 5 or TIA/EIA 568-B-compliant Enhanced Category 5 (Cat 5e) unshielded cabling.
- ❑ 10Gbps -Standard TIA/EIA 568-C-compliant Category 6a unshielded cabling.

LEDs This section explains the LEDs for the 100Mbps and 1/2.5/5/10Gbps twisted pair ports on the x950-28XTQm and x950-52XTQm switches. Each port has one LED that displays link and activity information. The LEDs are shown in Figure 5.

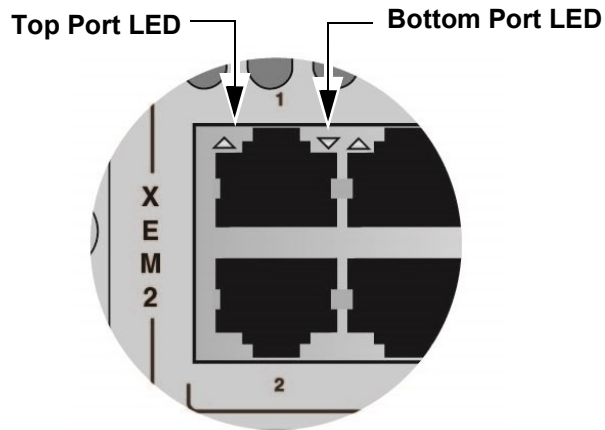

Figure 5. Link and Activity LEDs for Twisted Pair Ports on the x950-28XTQm and x950-52XTQm Switches

The states of the link and activity LEDs are described in Table 4.

Table 4. Link and Activity LEDs for Twisted Pair Ports on the x950-28XTQm and x950-52XTQm Switches

State	Description
Solid Green	The port has established a 2.5Gbps, 5Gbps, or 10Gbps link to a network device.
Flashing Green	The port is transmitting or receiving data at 2.5Gbps, 5Gbps or 10Gbps.
Solid Amber	The port has established a 100Mbps or 1Gbps link to a network device.
Flashing Amber	The port is transmitting or receiving data at 100Mbps or 1Gbps.

Table 4. Link and Activity LEDs for Twisted Pair Ports on the x950-28XTQm and x950-52XTQm Switches (Continued)

State	Description
Off	<p>Possible causes of this state are listed here:</p> <ul style="list-style-type: none"> - The port has not established a link with another network device. - The LEDs are turned off. To turn on the LEDs, use the eco-friendly button in the management panel or the NO ECOFRIENDLY LED command in the command line interface. <hr/> <p>Note The x950-52XSQ and x950-52XTQm switches do <i>not</i> have the eco-friendly button.</p>

Ports for 40Gbps QSFP+ or 100Gbps QSFP28 Transceivers, or Breakout Cables

The x950 series switch has four ports that support the transceivers and cables listed in Table 5.

Table 5. Ports for QSFP

	Port Number	40Gbps QSFP+ transceivers	100Gbps QSFP28 transceivers	40Gbps to 4 x 10Gbps breakout cables
x950-28XSQ	25, 29, 33, 37	Yes	Yes	Yes
x950-28XTQm	25, 29, 33, 37	Yes	Yes	Yes
x950-52XSQ	49, 53, 57, 61	Yes	Yes	Yes
x950-52XTQm	49, 53, 57, 61	Yes	Yes	Yes

QSFP28 Transceivers

The ports support the following 100Gbps QSFP28 transceivers:

- ❑ QSFP28SR4 transceiver - Maximum operating distance of 70m (230 ft) or 100m (328 ft) with 12-strand OM3 or OM4 fiber optic cable, respectively. Requires an MPO pluggable optical connector.
- ❑ QSFP28LR4 transceiver - Operating range of 2m (6.6 ft) to 10km (6.2 mi) with single-mode fiber optic cable. Requires a duplex LC connector.
- ❑ QSFP28-1CU and QSFP28-3CU direct attach cables - Lengths of one and three meters, respectively.

QSFP+ Transceivers

The ports support the following 40Gbps QSFP+ transceivers:

- ❑ QSFPSR4 transceiver - Maximum operating distance of 150m (492 ft) with 12-strand OM4 fiber optic cable.
- ❑ QSFPLR4 transceiver - Maximum operating distance of 2m (6.6 ft) to 10km (6.2 mi) with single-mode fiber optic cable.
- ❑ QSFP1CU and QSFP3CU direct attach cables - Lengths of 1 and 3 meters, respectively.

Breakout Cables

The ports also support copper and fiber optic break-out cables. The cables convert the ports from single 40Gbps ports to four SFP+ 10Gbps ports. The model names of the copper cables are QSFP-4SFP10G-3CU and QSFP-4SFP10G-5CU. They come in lengths of 3 and 5 meters, respectively. Refer to Figure 6 on page 25.

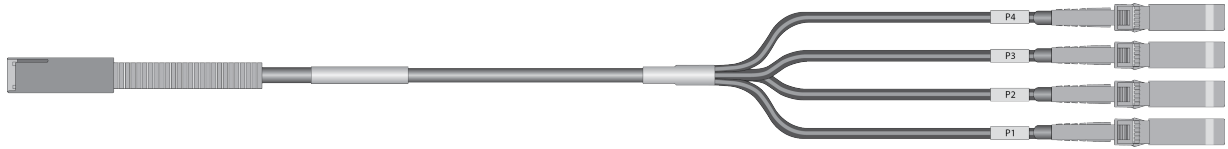

Figure 6. QSFP-4SFP10G-3CU and QSFP-4SFP10G-5CU Copper Breakout Cables

The fiber optic break-out cables are ET3-MPO08-4LC-5 and ET3-MPO08-4LC-10, in lengths of 5 and 10 meters, respectively. They have duplex LC connectors. Refer to Figure 7.

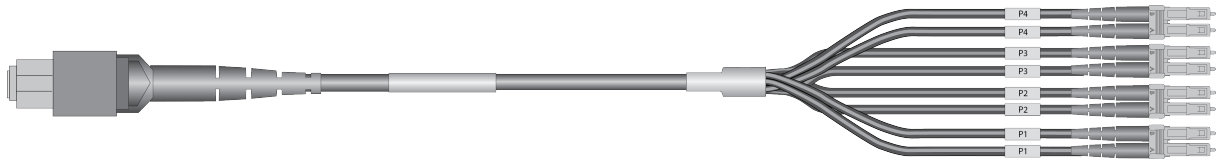

Figure 7. ET3-MPO08-4LC-5 and ET3-MPO08-4LC-10 Fiber Optic Breakout Cables

LEDs The ports for the QSFP28 and QSFP+ transceivers or breakout cable have one link and activity status LED each. Refer to Figure 8.

Top Transceiver or Breakout Cable LED

Bottom Transceiver or Breakout Cable LED

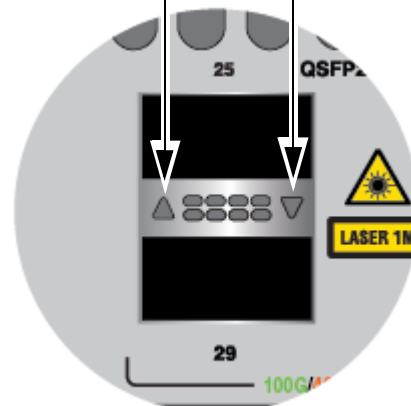

Figure 8. LEDs for Ports 25, 29, 33, and 37 on the x950-28XSQ and x950-28XTQm Switches

Ports 49, 53, 57, and 61 on the x950-52XSQ and x950-52XTQm switches have one link and activity status LED each. Refer to Figure 9.

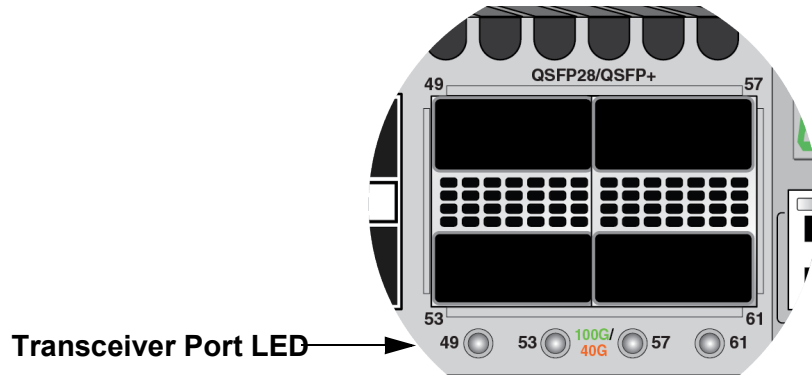

Figure 9. LEDs for Ports 49, 53, 57, and 61 on the x950-52XSQ and x950-52XTQm Switches

LEDs for 40Gbps QSFP+ and 100Gbps QSFP28 Transceivers

The states of the LEDs for 40Gbps QSFP+ or 100Gbps QSFP28 transceivers are defined in Table 6.

Note

For the LED states for breakout cables, see Table 7 on page 27.

Table 6. Link and Activity Status LEDs for 40Gbps QSFP+ or 100Gbps QSFP28 Transceivers

State	Description
Solid Green	The transceiver has established a 100Gbps link to a network device.
Flashing Green	The transceiver is transmitting or receiving data at 100Gbps.
Solid Amber	The transceiver has established a 40Gbps link to a network device.
Flashing Amber	The transceiver is transmitting or receiving data at 40Gbps.

Table 6. Link and Activity Status LEDs for 40Gbps QSFP+ or 100Gbps QSFP28 Transceivers (Continued)

State	Description
Off	<p>Possible causes of this state are listed here:</p> <ul style="list-style-type: none"> - The transceiver slot is empty. - The transceiver has not established a link to a network device. - The LEDs are turned off. To turn on the LEDs, use the eco-friendly button in the management panel or the NO ECOFRIENDLY LED command in the command line interface. <hr/> <p>Note The x950-52XSQ and x950-52XTQm switches do <i>not</i> have the eco-friendly button.</p>

LEDs for Breakout Cables

The LED states for breakout cables are described in Table 7.

Note

For the LED states for 40Gbps QSFP+ or 100Gbps QSFP28 transceivers, see Table 6 on page 26.

Table 7. Link and Activity Status LEDs for 10Gbps Breakout Cables

State	Description
Solid Amber	At least one of the four ports on the breakout cable has established a 10Gbps link to a network device.
Flashing Amber	At least one of the four ports on the breakout cable is sending or receiving data.

Table 7. Link and Activity Status LEDs for 10Gbps Breakout Cables

State	Description
Off	<p>Possible causes of this state are listed here:</p> <ul style="list-style-type: none"> - The transceiver slot is empty. - None of the ports on the breakout cable have established a link to a network device. - The LEDs are turned off. To turn on the LEDs, use the eco-friendly button in the management panel or the NO ECOFRIENDLY LED command in the command line interface. <hr/> <p>Note The x950-52XSQ and x950-52XTQm switches do <i>not</i> have the eco-friendly button.</p>

**Port Numbering
for the
x950-28XSQ and
x950-28XTQm
Switches**

Table 8 lists the port numbering system for ports 25, 29, 33, and 37 on the x950-28XSQ and x950-28XTQm switches when the switch is operating as a stand-alone unit (i.e., the VCStack feature is disabled):

Table 8. Port Numbering for Ports 25 to 37

Port	With Fiber Optic Transceiver or Direct Attach Cable	With Breakout Cable
25	port1.0.25	port1.0.25 port1.0.26 port1.0.27 port1.0.28
29	port1.0.29	port1.0.29 port1.0.30 port1.0.31 port1.0.32
33	port1.0.33	port1.0.33 port1.0.34 port1.0.35 port1.0.36
37	port1.0.37	port1.0.37 port1.0.38 port1.0.39 port1.0.40

**Port Numbering
for the
x950-52XSQ and
x950-52XTQm
Switches**

Table 9 lists the port numbering system for ports 49, 53, 57, and 61 on the x950-52XSQ and x950-52XTQm switches when the switch is operating as a stand-alone unit (i.e., the VCStack feature is disabled):

Table 9. Port Numbering for Ports 49, 53, 57, and 61

Port	With Fiber Optic Transceiver or Direct Attach Cable	With Breakout Cable
49	port1.0.49	port1.0.49 port1.0.50 port1.0.51 port1.0.52
53	port1.0.53	port1.0.53 port1.0.54 port1.0.55 port1.0.56
57	port1.0.57	port1.0.57 port1.0.58 port1.0.59 port1.0.60
61	port1.0.61	port1.0.61 port1.0.62 port1.0.63 port1.0.64

For more information, refer to “Designating Ports in the Command Line Interface” on page 42.

Management Panel

The components on the management panel for the x950-28XSQ and x950-28XTQm switches are identified in Figure 10.

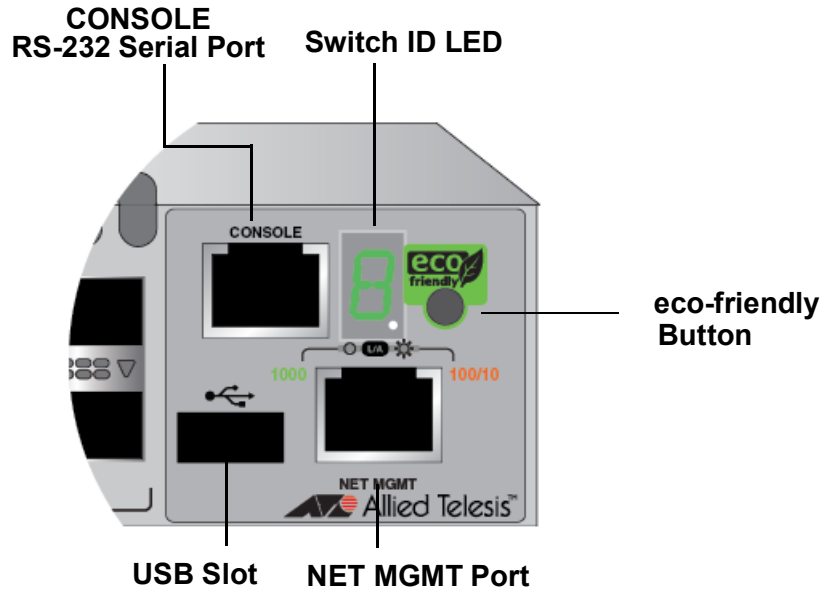

Figure 10. Management Panel for the x950-28XSQ and x950-28XTQm Switches

The components on the management panel for the x950-52XSQ and x950-52XTQm switches are identified in Figure 11.

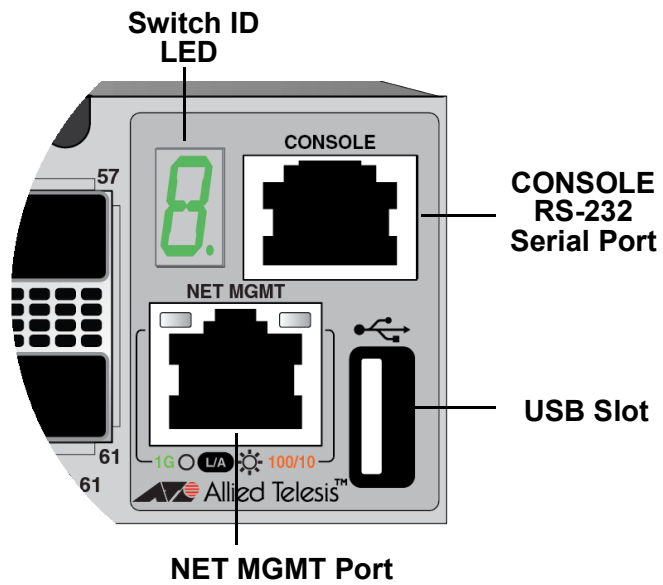

Figure 11. Management Panel for the and x950-52XSQ and x950-52XTQm Switches

USB Port You can use the USB port with a flash drive for the following functions:

- ❑ Provide a centralized network backup location for Autonomous Management Framework.
- ❑ Store backup copies of configuration files.
- ❑ Transfer configuration files between switches that are to have similar configurations.
- ❑ Store or transfer log files.
- ❑ Store or transfer debug files (for example, the output of the SHOW TECH-SUPPORT command).
- ❑ Boot the AlliedWare Plus operating system and master configuration file from flash drive.

Using a flash drive with the switch is optional.

NET MGMT Ethernet Management Port

The switch uses the NET MGMT port as a separate routed eth0 interface. The interface is not part of the switching matrix, but the switch can route traffic in or out of the port from the network ports and Ethernet line card. Here are the guidelines:

- ❑ The port should only be used for initial configuration and maintenance access to the chassis.
- ❑ The NET MGMT port has a standard 8-pin RJ-45 connector and operates at 10, 100, or 1000 Mbps in either half- or full-duplex mode.
- ❑ The default setting for the port is Auto-Negotiation, which sets the speed and duplex mode automatically. You may disable Auto-Negotiation and configure the port manually.
- ❑ The wiring configuration of the NET MGMT port is set automatically with automatic MDIX detection. You can disable automatic MDIX detection and set the wiring configuration manually.
- ❑ The port is referred to as eth0 in the management software.

The minimum cable requirements for the port are listed here:

- ❑ 10 or 100Mbps - Standard TIA/EIA 568-B-compliant Category 3 unshielded cabling.
- ❑ 1000Mbps - Standard TIA/EIA 568-A-compliant Category 5 or TIA/EIA 568-B-compliant Enhanced Category 5 (Cat 5e) unshielded cabling.

For instructions on how to configure the NET MGMT port, refer to the *Software Reference for x950 Switch, AlliedWare Plus Operating System*.

The Network Management (NET MGMT) port has one Status LED, described in Table 10.

Table 10. NET MGMT Port LED

State	Description
Solid Green	The port has established a 1000 Mbps link with a network device.
Flashing Green	The port is transmitting or receiving data at 1000 Mbps.
Solid Amber	The port has established a 10 or 100 Mbps link.
Flashing Amber	The port is transmitting or receiving data at 10 or 100 Mbps.
Off	The port has not established a link to a network device.

Console (RS-232) Port

You use the Console Port to conduct local management sessions with the switch. Local management sessions require a terminal or PC with a terminal emulation program, and the management cable that comes with the switch. The switch does not need an Internet Protocol (IP) address for local management sessions because they are not conducted over a network. For instructions, refer to “Starting a Local Management Session” on page 162.

Note

The first management session of the switch can be either a local session or a remote session over your network through the NET MGMT port. For remote management, the switch uses either its default IP address 192.168.42.42 or an address assigned to it by a DHCP server. For instructions on remote management sessions, refer to the *Software Reference for x950 Switches, AlliedWare Plus Operating System*.

Switch ID LED

The Switch ID LED, shown in Figure 10 on page 30 or Figure 11 on page 30, displays a variety of information. Figure 12 on page 33 shows the states of the LED when the eco-friendly mode is disabled.

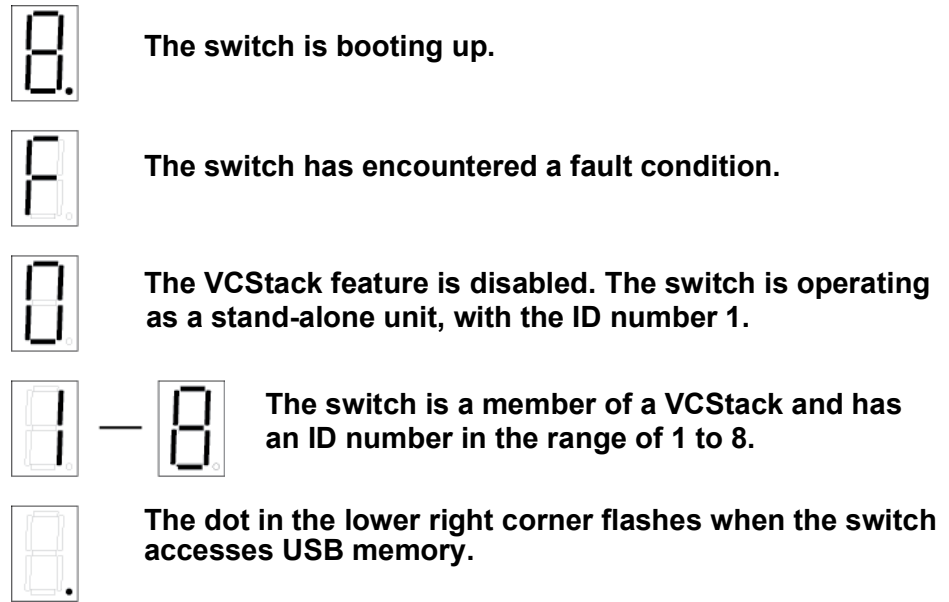

Figure 12. Switch ID LED with the eco-friendly Mode Disabled

The switch displays the letter “F” for fault on the ID LED if it detects one of the following problems:

- A cooling fan has failed.
- The switch is about to shut down because its internal temperature is outside the normal operating range.

Note

You can use the `SHOW SYSTEM ENVIRONMENT` command in the command line interface to identify the source of the problem.

Figure 13 illustrates the states of the LED when the eco-friendly mode is enabled and the switch is operating in the low power mode.

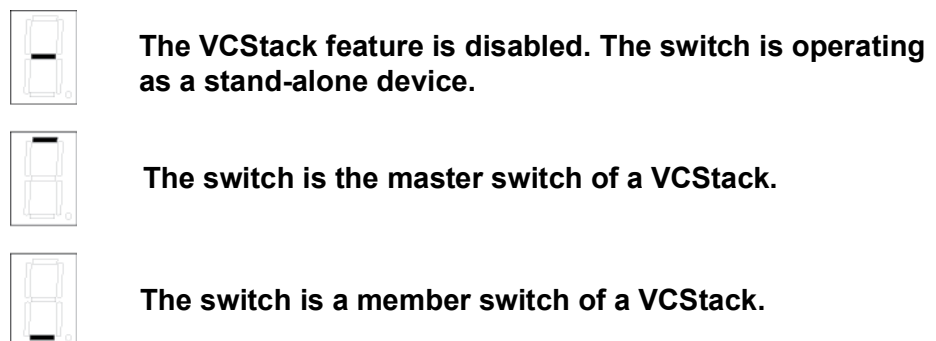

Figure 13. Switch ID LED with the eco-friendly Mode Enabled

eco-friendly Button

You use the eco-friendly button on the management panel to turn the LEDs on or off. You might turn off the LEDs when you are not using them to monitor the switch, to conserve electricity. When the LEDs are off, the overall power consumption of the chassis is reduced by approximately 2 watts.

The button controls all the port LEDs, except for the L/A LED for the NET MGMT port. Additionally, the button does not control the LEDs on the power supplies.

Note

The x950-52XSQ and x950-52XTQm switches do *not* have the eco-friendly button; however, the eco-friendly mode can be turned on or off with the ECOFRIENDLY LED or NO ECOFRIENDLY LED command in the Command Line Interface.

Optional Direct Attach Cables

The optional direct attach cables listed in Table 11 offer an economical way to add 10Gbps, 40Gbps, or 100Gbps connections over short distances for switch base ports or ports on XEM2 Line Cards.

Table 11. Optional Direct Attach Cables

Switch Ports	XEM2 Line Card	Speed	Direct Attach Cable
Ports 1 to 24 on x950-28XSQ Ports 1 to 48 on x950-52XSQ	XEM2-8XSTm XEM2-12XS XEM2-12XS v2 ¹	10Gbps	SP10TW1 - 1 meter SP10TW3 - 3 meters SP10TW7 - 7 meters
Ports 25, 29, 33, 37 on x950-28XSQ and x950-28XTQm	XEM2-4QS	40Gbps	QSFP1CU - 1 meter QSFP3CU - 3 meters
Ports 49, 53, 57, 61 on x950-52XSQ and x950-52XTQm	XEM2-1CQ	100Gbps	QSFP28-1CU - 1 meter QSFP28-3CU - 3 meters

1. The XEM2-12XS v2 Card supports the SP10TW1 and SP10TW3 cables. It does not support the SP10TW7 cable.

PWR600 AC and DC Power Supplies

The x950 series switch supports the PWR600 AC and PWR600 DC power supply units.

Here are power supply guidelines:

- ❑ You can install either one or two power supplies in the switch.
- ❑ A single power supply can power a fully equipped switch.
- ❑ Installing two power supplies adds power redundancy.
- ❑ You can install two PWR600 AC modules, two PWR600 DC modules, or a combination of the PWR600 AC and PWR600 DC modules on one switch.
- ❑ The power supplies are installed in the PSU A and PSU B slots in the rear panel of the chassis. If you are installing only one power supply, Allied Telesis recommends installing it in PSU A slot because that slot does not come with a blank slot cover.
- ❑ The switch does not come with power supplies. They are purchased separately.
- ❑ The power supplies are field-replaceable and hot-swappable. If the switch has two power supplies and one fails, you do not have to power off the operational power supply to replace the failed unit.

**PWR600 AC
Power Supply**

The PWR600 AC module is an AC power supply for the switch. The model name can be found on a label on the release tab on the front panel. Refer to Figure 14.

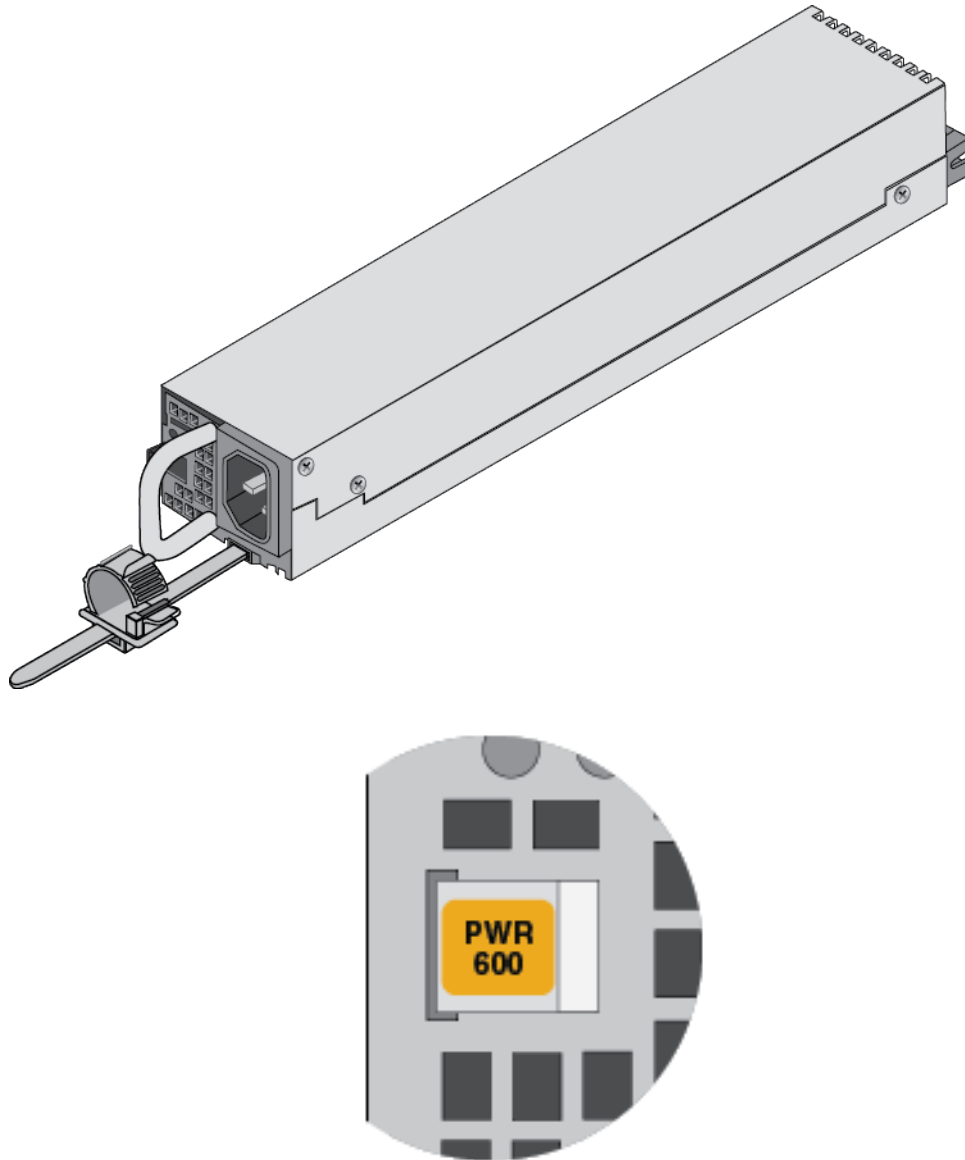

Figure 14. PWR600 Power Supply

LEDs

The two LEDs on the front panel of the power supply are described in Table 12 on page 38.

Table 12. LEDs on the PWR600 Power Supply

Green LED	Amber LED	Description
Solid green	Off	The power supply is operating normally.
Blinking green	Off	The power supply is in the standby mode.
Solid green	Blinking amber	<p>The power supply is experiencing a warning condition, but is still operating. Possible causes are listed here:</p> <ul style="list-style-type: none"> - The power supply is overheating. - The speed of its fan is too low. - Its output current is too high. - The input voltage from the AC power source is too low.
Off	Solid amber	<p>The power supply shut down because it experienced a fault condition. Possible causes are listed here:</p> <ul style="list-style-type: none"> - The power supply overheated. - The power supply's fan stopped or was too slow. - The output current from the power supply to the switch was too high. - The input voltage from the AC power source was too low.

PWR600 DC Power Supply

The PWR600 DC module is a DC power supply for the switch. Refer to Figure 15.

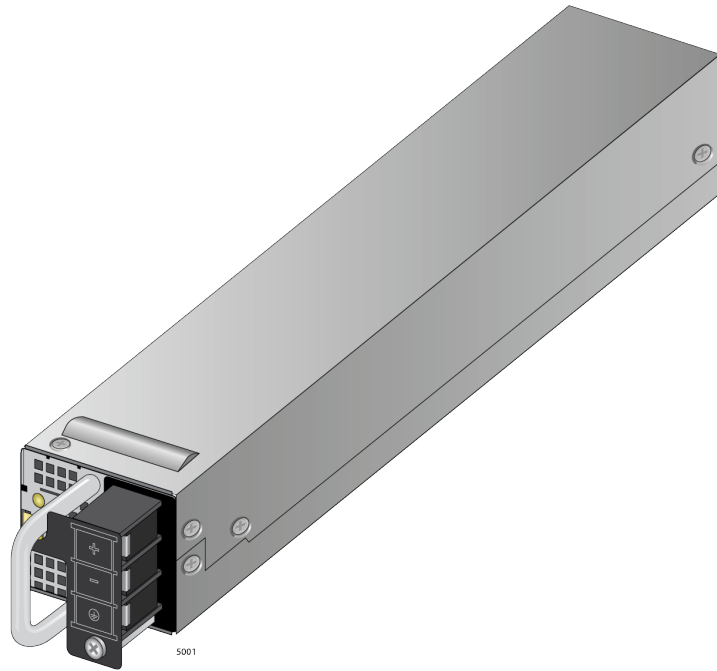

Figure 15. PWR600 DC Power Supply

LEDs

The PWR600 DC power supply has the two LEDs on the front panel as shown in Figure 16. See Table 13 for the descriptions.

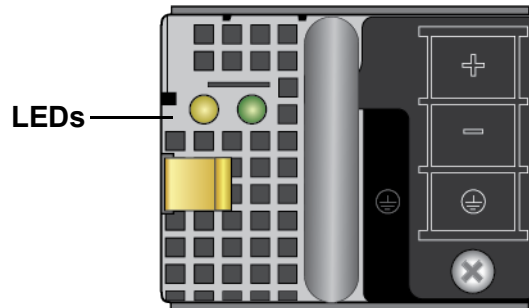

Figure 16. LEDs for PWR600 DC Power Supply

Table 13. LEDs on the PWR600 DC Power Supply

Green LED	Amber LED	Description
Solid green	Off	The power supply is operating normally.
Blinking green	Off	The power supply is in the standby mode.

Table 13. LEDs on the PWR600 DC Power Supply (Continued)

Green LED	Amber LED	Description
Solid green	Blinking amber	<p>The power supply is experiencing a warning condition, but is still operating. Possible causes are listed here:</p> <ul style="list-style-type: none"> - The power supply is overheating. - The speed of its fan is too low. - Its output current is too high. - The input voltage from the DC power source is too low.
Off	Solid amber	<p>The power supply shut down because it experienced a fault condition. Possible causes are listed here:</p> <ul style="list-style-type: none"> - The power supply overheated. - The power supply's fan stopped or was too slow. - The output current from the power supply to the switch was too high. - The input voltage from the DC power source was too low.

FAN05 Cooling Fan

The cooling unit for the chassis is the FAN05 fan module. Refer to Figure 17.

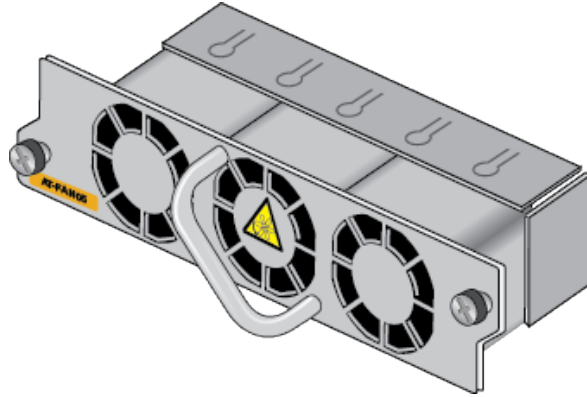

Figure 17. FAN05 Fan Module

Here are the fan module guidelines:

- ❑ The switch comes with two pre-installed fan modules in FAN A and FAN B slots on the rear panel.
- ❑ The fan modules are field-replaceable and hot-swappable. You do not have to power off the switch to replace them.
- ❑ The switch automatically adjusts the fan speeds according to its internal temperature.

Designating Ports in the Command Line Interface

The individual ports on the switch are identified with the PORT parameter in the command line interface of the AlliedWare Plus management software. The format of the parameter is shown in Figure 18.

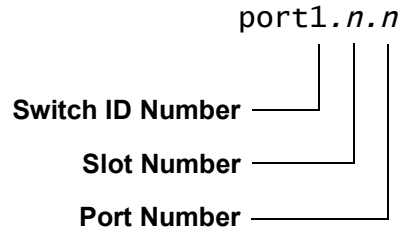

Figure 18. PORT Parameter in the Command Line Interface

The three parts of the PORT parameter are described in Table 14.

Table 14. PORT Parameter Format

Number	Description
Switch ID Number	<p>Identifies the switch’s ID number. Please review the following:</p> <ul style="list-style-type: none"> - The default value is 1. - Allied Telesis recommends using the default value for stand-alone switches. - A stand-alone switch that was previously a stack member retains its ID number from the stack. - The Switch ID LED on the front panel of the switch always displays “0” when the VCStack feature is disabled.
Slot Number	<p>Identifies whether ports are base ports or ports on an XEM2 Line Card. Slot number 0 indicates base ports and slot number 1 indicates ports on a line card. Refer to Figure 19 on page 43.</p> <hr style="width: 20%; margin-left: auto; margin-right: 0;"/> <p>Note The x950-52XSQ and x950-52XTQm switches have base ports only.</p> <hr style="width: 20%; margin-left: auto; margin-right: 0;"/>
Port Number	Identifies a port number.

Base Ports and Line Card Ports

Ports on the switch are called base ports to distinguish from ports on an XEM2 line card.

Figure 19 identifies the slot numbers for line card ports and base ports.

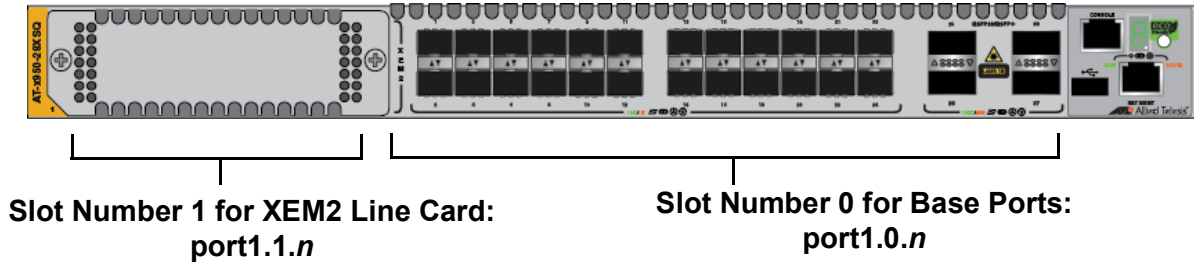

Figure 19. Slot Numbers for Port Numbering

Note

The x950-52XSQ and x950-52XTQm switches have base ports only.

Examples for the PORT Parameter on Base Ports

Here are examples of the PORT parameter on base ports in the INTERFACE command for stand-alone switches.

The first example enters the port Interface mode for base ports 11 and 14:

```
awplus> enable
awplus# configure terminal
awplus(config)# interface port1.0.11,port1.0.14
```

This example enters the port Interface mode for base ports 6 to 10:

```
awplus(config)# interface port1.0.6-1.0.10
```

Note

You must include the PORT parameter when identifying individual ports, and omit it from the last port when specifying ranges.

**Examples for the
PORT Parameter
on an XEM2 Line
Card**

The x950-28XSQ and x950-28XTQm switches can have an XEM2 line card installed.

This example enters the port Interface mode for ports 4 and 5 on an XEM2 Line Card in the expansion slot:

```
awplus(config)# interface port1.1.4,port1.1.5
```

This example enters the port Interface mode for port 6 in the base ports and port 5 on a line card:

```
awplus(config)# interface port1.0.6,port1.1.5
```

For further instructions, refer to the *Software Reference for x950 Switch, AlliedWare Plus Operating System*.

Software and Hardware Releases

The software and hardware releases for the AlliedWare Plus operating software and x950 Switches are listed in Table 15.

Table 15. Software and Hardware Releases

Software Version	Hardware / VCStack
v5.4.8-2	x950-28XSQ Switch XEM2-12XT Line Card XEM2-12XS Line Card XEM2-4QS Line Card XEM2-1CQ Line Card VCStack - Stacks up to two switches.
v5.4.9	VCStack - Stacks up to four switches.*
v5.4.9-1	x950-28XTQm Switch XEM2-12XTm Line Card XEM2-12XT Line Card - Added 100Mbps port speed
v5.4.9-2	XEM2-8XSTm Line Card XEM2-12XS v2 Line Card
v5.4.9-2.3	VCStack - Stacks up to eight switches.*
v5.5.0-1	x950-52XSQ Switch
v5.5.1-0.1	x950-52XTQm Switch

* For more information, see the *x950 Series Switches Installation Guide for Virtual Chassis Stacking*.

Chapter 2

XEM2 Ethernet Line Cards

The chapter contains the following sections:

- “Overview” on page 48
- “XEM2-8XSTm Line Card” on page 51
- “XEM2-12XT Line Card” on page 55
- “XEM2-12XTm Line Card” on page 57
- “XEM2-12XS and XEM2-12XS v2 Line Cards” on page 59
- “XEM2-4QS Line Card” on page 62
- “XEM2-1CQ Line Card” on page 64

Overview

The x950-28XSQ and x950-28XTQm switches have one expansion slot on the front panel for an optional XEM2 Ethernet line card. See Figure 20.

Note

The x950-52XSQ and x950-52XTQm switches do *not* support the XEM2 line cards.

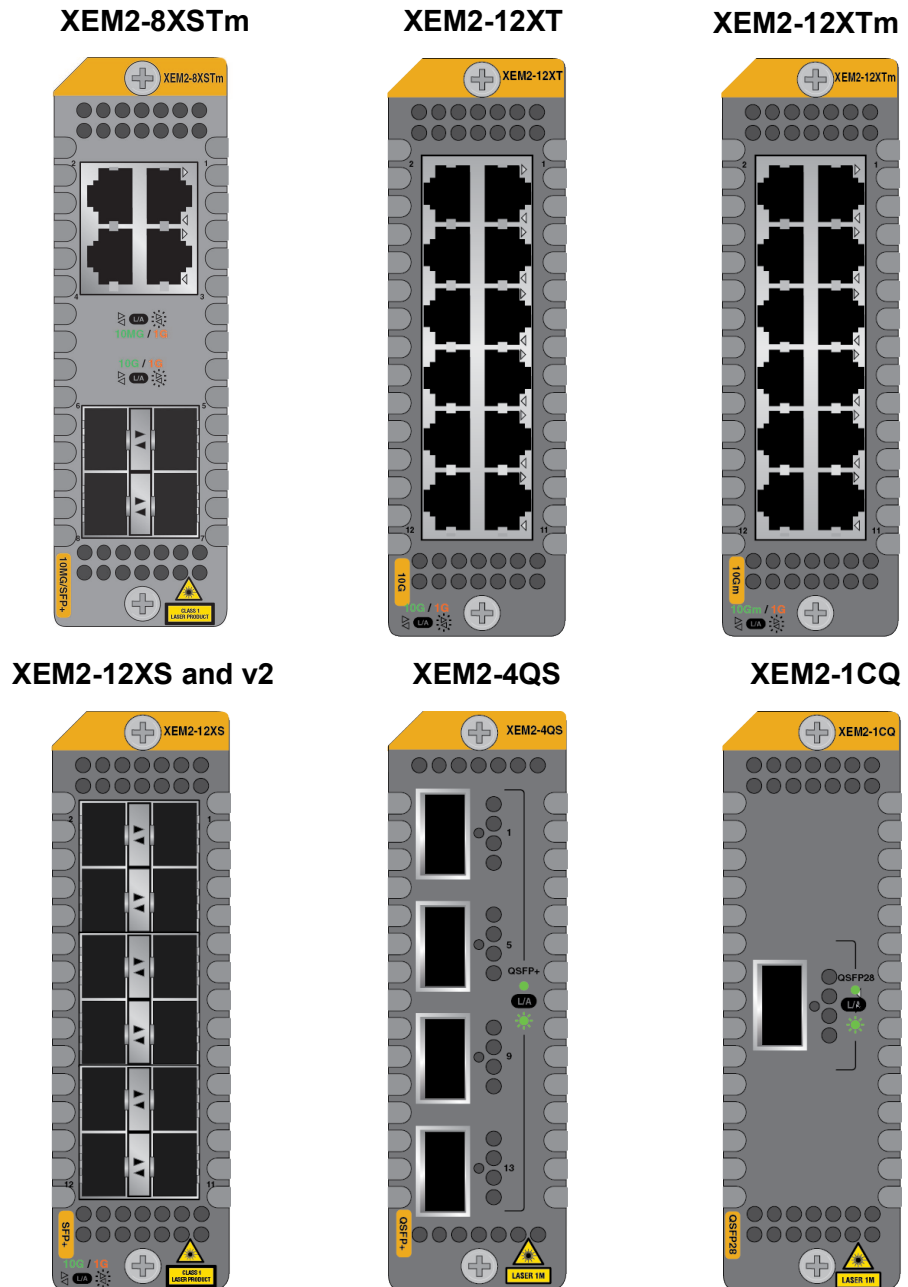

Figure 20. XEM2 Ethernet Line Cards

The XEM2 Ethernet line cards are described in Table 16.

Table 16. XEM2 Ethernet Line Cards

Line Card	Description
XEM2-8XSTm	<p>Four twisted pair ports (1-4) with RJ-45 connectors that support the following speeds:</p> <ul style="list-style-type: none"> - 100Mbps - 1/2.5/5/10Gbps <p>Four ports (5-8) that support the following types of transceivers:</p> <ul style="list-style-type: none"> - 1Gbps SFP - 10Gbps SFP+ - 10Gbps one meter SP10TW1 and three meter SP10TW3 direct connect twinax cables. (The card does not support the seven meter SP10TW7 cable.) <p>Refer to “XEM2-8XSTm Line Card” on page 51.</p>
XEM2-12XT	<p>12 twisted pair ports with RJ-45 connectors that support the following speeds:</p> <ul style="list-style-type: none"> - 100Mbps (requires AlliedWare Plus v5.4.9-0 or later.) - 1/10Gbps <p>Refer to “XEM2-12XT Line Card” on page 55.</p>
XEM2-12XTm	<p>12 twisted pair ports with RJ-45 connectors that support the following speeds:</p> <ul style="list-style-type: none"> - 100Mbps - 1/2.5/5/10Gbps <p>Refer to “XEM2-12XTm Line Card” on page 57. (This card requires AlliedWare Plus v5.4.9-0 or later.)</p>

Table 16. XEM2 Ethernet Line Cards (Continued)

Line Card	Description
<p>XEM2-12XS and XEM2-12XS v2</p>	<p>12 ports that support the following types of transceivers:</p> <ul style="list-style-type: none"> - 1Gbps SFP - 10Gbps SFP+ - 10Gbps one meter SP10TW1, three meter SP10TW3, and seven meter SP10TW7 direct connect twinax cables (The XEM2-12XS v2 Card does not support the SP10TW7 cable.) <p>Refer to “XEM2-12XS and XEM2-12XS v2 Line Cards” on page 59.</p>
<p>XEM2-4QS</p>	<p>Four ports that support the following types of transceivers:</p> <ul style="list-style-type: none"> - 40Gbps QSFP+ transceivers - 40Gbps QSFPCU direct connect cables - QSFP-4SFP10G-3CU and QSFP-4SFP10G-5CU 40Gbps to 4 x 10Gbps breakout cables <p>Refer to “XEM2-4QS Line Card” on page 62.</p>
<p>XEM2-1CQ</p>	<p>One port for the 100Gbps QSFP28 transceiver or QSFP28-1CU or QSFP28-3CU direct attach cable. Refer to “XEM2-1CQ Line Card” on page 64.</p>

- ❑ The XEM2-8XSTm Card requires AlliedWare Plus v5.4.9-2 or later.
- ❑ The 100Mbps port speed on the XEM2-12XT Card requires AlliedWare Plus v5.4.9-0 or later.
- ❑ The XEM2-12XTm Card requires AlliedWare Plus v5.4.9-0 or later.

For more information, refer to “Software and Hardware Releases” on page 45.

XEM2-8XSTm Line Card

The XEM2-8XSTm Line Card is shown in Figure 21.

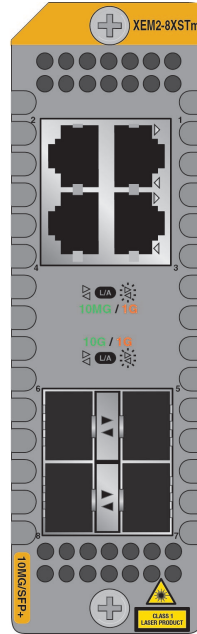

Figure 21. XEM2-8XSTm Line Card

Twisted Pair Ports

The XEM2-8XSTm Card has four twisted pair ports and four SFP ports. The specifications for the twisted pair ports are listed in Table 17.

Table 17. Twisted Pair Ports on the XEM2-8XSTm Line Card

Specification	Description
Port Speed	<p>The ports support the following speeds:</p> <ul style="list-style-type: none"> - 100Mbps - 1/2.5/5/10Gbps <p>The ports do not support 10Mbps.</p> <p>You can set port speed with Auto-Negotiation or manually. The default is Auto-Negotiation.</p>
Duplex Mode	Full-duplex only.

Table 17. Twisted Pair Ports on the XEM2-8XSTm Line Card (Continued)

Specification	Description
Cabling	Minimum cable requirements are: <ul style="list-style-type: none"> - 100Mbps - Standard TIA/EIA 568-B-compliant Category 3 unshielded cabling. - 1/2.5/5Gbps - Standard TIA/EIA 568-A-compliant Category 5 or TIA/EIA 568-B-compliant Enhanced Category 5 (Cat 5e) unshielded cabling. - 10Gbps -Standard TIA/EIA 568-C-compliant Category 6a unshielded cabling.
Maximum Distance	100 meters (328 feet)
Connector	8-pin RJ-45

Twisted Pair Port LEDs

Each port has a single LED that displays link and activity information. The states of LEDs are described in Table 18.

Table 18. Link and Activity LEDs for the Twisted Pair Ports on the XEM2-8XSTm Line Card

State	Description
Solid Green	The port has established a 2.5Gbps, 5Gbps, or 10Gbps link to a network device.
Flashing Green	The port is transmitting or receiving data at 2.5Gbps, 5Gbps, or 10Gbps.
Solid Amber	The port has established a 100Mbps or 1Gbps link to a network device.
Flashing Amber	The port is transmitting or receiving data at 100Mbps or 1Gbps.

Table 18. Link and Activity LEDs for the Twisted Pair Ports on the XEM2-8XSTm Line Card (Continued)

State	Description
Off	<p>Possible causes of this state are listed here:</p> <ul style="list-style-type: none"> - The port has not established a link with another network device. - The LEDs are turned off. To turn on the LEDs, use the eco-friendly button in the management panel or the NO ECOFRIENDLY LED command in the command line interface.

Transceiver Ports

The XEM2-8XSTm Card also has four transceiver ports that support the following types of 1Gbps SFP or 10Gbps SFP+ transceivers:

- 1Gbps SX or LX SFP fiber optic transceivers
- 10Gbps SR or LR SFP+ fiber optic transceivers
- 10Gbps one meter SP10TW1 and three meter SP10TW3 direct connect twinax cables, with SFP+ transceiver-style connectors

Note

The XEM2-8XSTm Card does not support the seven meter SP10TW7 direct connect cable.

Guidelines about the SFP+ transceiver ports are listed here:

- The ports do not support 100Mbps transceivers.
- The ports support full-duplex mode only.
- You can set the port speeds with Auto-Negotiation or manually. The default is Auto-Negotiation.

SFP and SFP+ transceivers are purchased separately. For a list of supported transceivers, refer to the SBx908 GEN2 Series data sheet on the Allied Telesis web site.

Transceiver Port LEDs

The ports have link and activity LEDs. The states of the LEDs are described in Table 19.

Table 19. Link and Activity LEDs for the SFP Ports on the XEM2-8XSTm Line Card

State	Description
Solid Green	The transceiver in the slot has established a 10GBase link to a network device.
Flashing Green	The transceiver is transmitting or receiving data at 10GBase.
Solid Amber	The transceiver has established a 1GBase link to a network device.
Flashing Amber	The transceiver is transmitting or receiving data at 1GBase.
Off	<p>Possible causes of this state are listed here:</p> <ul style="list-style-type: none"> - The transceiver has not established a link with another network device. - The LEDs are turned off. To turn on the LEDs, use the eco-friendly button in the management panel or the NO ECOFRIENDLY LED command in the command line interface.

XEM2-12XT Line Card

The XEM2-12XT Line Card is shown in Figure 22.

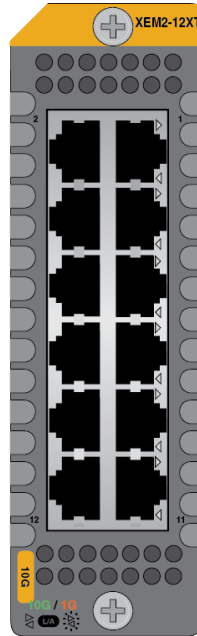

Figure 22. XEM2-12XT Line Card

Twisted Pair Ports

The card has 12 twisted pair ports with standard 8-pin RJ-45 ports. The specifications of the ports are listed in Table 20.

Table 20. Twisted Pair Ports on the XEM2-12XT Line Card

Specification	Description
Port Speed	<p>The ports support the following speeds:</p> <ul style="list-style-type: none"> - 100Mbps (Requires AlliedWare Plus v5.4.9-0 or later) - 1/10Gbps <p>The ports do not support 10Mbps.</p>
Duplex Mode	Full-duplex only

Table 20. Twisted Pair Ports on the XEM2-12XT Line Card (Continued)

Specification	Description
Cabling	The minimum cable requirements are: <ul style="list-style-type: none"> - 100Mbps - Standard TIA/EIA 568-B-compliant Category 3 unshielded cabling. - 1Gbps - Standard TIA/EIA 568-A-compliant Category 5 or TIA/EIA 568-B-compliant Enhanced Category 5 (Cat 5e) unshielded cabling. - 10Gbps -Standard TIA/EIA 568-C-compliant Category 6a unshielded cabling.
Maximum Distance	100 meters (328 feet)
Connector	8-pin RJ-45

LEDs Each port has a single LED that displays link and activity information. Refer to Table 21.

Table 21. Port Link and Activity LEDs on the XEM2-12XT Line Card

State	Description
Solid Green	The port has established a 10GBase link to a network device.
Flashing Green	The port is transmitting or receiving data at 10GBase.
Solid Amber	The port has established a 100Mbps or 1GBase link to a network device.
Flashing Amber	The port is transmitting or receiving data at 100Mbps or 1GBase.
Off	Possible causes of this state are listed here: <ul style="list-style-type: none"> - The port has not established a link with another network device. - The LEDs are turned off. To turn on the LEDs, use the eco-friendly button in the management panel or the NO ECOFRIENDLY LED command in the command line interface.

XEM2-12XTm Line Card

The XEM2-12XTm Card is shown in Figure 23.

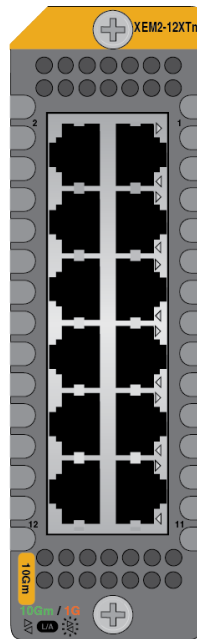

Figure 23. XEM2-12XTm Line Card

Twisted Pair Ports

The XEM2-12XTm Card has 12 twisted pair ports with standard 8-pin RJ-45 ports. The specifications of the ports are listed in Table 22.

Table 22. Twisted Pair Ports on the XEM2-12XTm Line Card

Specification	Description
Port Speed	<p>The ports support the following speeds:</p> <ul style="list-style-type: none"> - 100Mbps - 1/2.5/5/10Gbps <p>The ports do not support 10Mbps.</p> <p>You can set port speed with Auto-Negotiation or manually. The default is Auto-Negotiation.</p>
Duplex Mode	Full-duplex only.

Table 22. Twisted Pair Ports on the XEM2-12XTm Line Card (Continued)

Specification	Description
Cabling	The minimum cable requirements are: <ul style="list-style-type: none"> - 100Mbps - Standard TIA/EIA 568-B-compliant Category 3 unshielded cabling. - 1/2.5/5Gbps - Standard TIA/EIA 568-A-compliant Category 5 or TIA/EIA 568-B-compliant Enhanced Category 5 (Cat 5e) unshielded cabling. - 10Gbps -Standard TIA/EIA 568-C-compliant Category 6a unshielded cabling.
Maximum Distance	100 meters (328 feet)
Connector	8-pin RJ-45

LEDs Each port has a single LED that displays link and activity information. The states of LEDs are described in Table 23.

Table 23. Link and Activity LEDs on the XEM2-12XTm Line Card

State	Description
Solid Green	The port has established a 2.5Gbps, 5Gbps, or 10Gbps link to a network device.
Flashing Green	The port is transmitting or receiving data at 2.5Gbps, 5Gbps, or 10Gbps.
Solid Amber	The port has established a 100Mbps or 1GBase link to a network device.
Flashing Amber	The port is transmitting or receiving data at 100Mbps or 1GBase.
Off	Possible causes of this state are listed here: <ul style="list-style-type: none"> - The port has not established a link with another network device. - The LEDs are turned off. To turn on the LEDs, use the eco-friendly button in the management panel or the NO ECOFRIENDLY LED command in the command line interface.

XEM2-12XS and XEM2-12XS v2 Line Cards

The XEM2-12XS Line Card is shown in Figure 24.

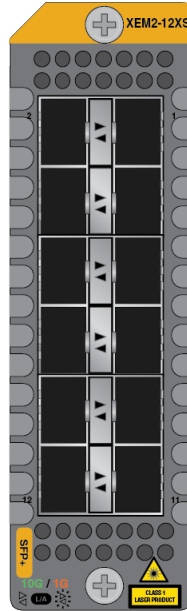

Figure 24. XEM2-12XS Line Card

Transceiver Ports

The card has twelve ports that support the following types of 1Gbps SFP, 10Gbps SFP+, and 1/2.5/5/10Gbps transceivers with RJ-45 connectors:

- 1Gbps SX or LX SFP transceivers
- 1Gbps SPTX transceivers with RJ-45 ports for twisted pair cable
- 10Gbps SR or LR SFP+ fiber optic transceivers
- 10Gbps one meter SP10TW1, three meter SP10TW3, and seven meter SP10TW7 direct connect twinax cables with SFP+ transceiver-style connectors
- 1Gbps/10Gbps SP10T transceivers with RJ-45 ports for twisted pair cable
- 1Gbps/2.5Gbps/5Gbps/10Gbps SP10TM transceivers with RJ-45 ports for twisted pair cable

Note

The XEM2-12XS v2 Card does not support the seven meter SP10TW7 direct connect cable.

Guidelines about the ports are listed here:

- ❑ They do not support 100Mbps transceivers.
- ❑ They support full-duplex mode only.
- ❑ You can set the port speeds with Auto-Negotiation or manually. The default is Auto-Negotiation.

SFP or SFP+ transceivers must be purchased separately. For a list of supported transceivers, refer to the x950 Switches data sheet on the Allied Telesis web site.

Card Versions

There are two versions of the XEM2-12XS Line Card. Their names are “XEM2-12XS” and “XEM2-12XS v2.” Refer to Figure 25.



Figure 25. XEM2-12XS and XEM2-12XS v2 Line Cards

Note

The XEM2-12XS v2 Line Card requires AlliedWare Plus v5.4.9-2 or later.

Note

Unless stated otherwise, the “XEM2-12XS” model name in this manual refers to both cards.

LEDs

The ports have link and activity LEDs. The LED states are described in Table 24.

Table 24. Port Link and Activity LEDs on the XEM2-12XS Line Card

State	Description
Solid Green	The transceiver has established a 2.5Gbps, 5Gbps, or 10Gbps link to a network device.
Flashing Green	The transceiver is transmitting or receiving data at 2.5Gbps, 5Gbps, or 10Gbps.

Table 24. Port Link and Activity LEDs on the XEM2-12XS Line Card

State	Description
Solid Amber	The transceiver has established a 1GBase link to a network device.
Flashing Amber	The transceiver is transmitting or receiving data at 1GBase.
Off	<p>Possible causes of this state are listed here:</p> <ul style="list-style-type: none"> - The transceiver has not established a link with another network device. - The LEDs are turned off. To turn on the LEDs, use the eco-friendly button in the management panel or the NO ECOFRIENDLY LED command in the command line interface.

XEM2-4QS Line Card

The XEM2-4QS Line Card is shown in Figure 26.

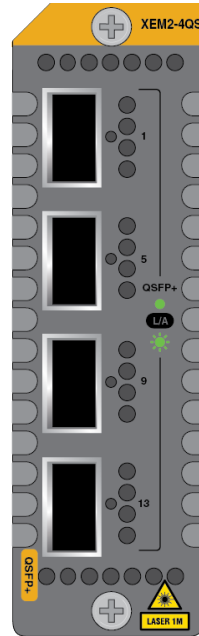

Figure 26. XEM2-4QS Line Card

Transceiver Ports

The card supports the following types of 40Gbps QSFP+ transceivers in its four ports:

- ❑ QSFP4SR4 transceiver - Maximum operating distance of 150 meters (492 feet) with 12-strand OM4 fiber optic cable.
- ❑ QSFP4LR4 transceiver - Operating range of 2 meters (6.6 feet) to 10 kilometers (6.2 miles) with single-mode fiber optic cable.
- ❑ QSFP1CU and QSFP3CU direct attach cables - Lengths of 1 and 3 meters, respectively.
- ❑ QSFP-4SFP10G-3CU and QSFP-4SFP10G-5CU 40Gbps to 4 x 10Gbps breakout cables in lengths of 3 and 5 meters, respectively. Refer to “Breakout Cables” on page 24 for more information.

LEDs The LED states for transceivers or direct attach cables in ports on the XEM2-4QS Line Card are described in Table 25.

Table 25. Port Link and Activity Status LEDs on the XEM2-4QS Line Card

State	Description
Solid Green	The transceiver has established a 40GBase link to a network device.
Flashing Green	The transceiver is transmitting or receiving data.
Off	<p>Possible causes of this state are listed here:</p> <ul style="list-style-type: none"> - The transceiver port is empty. - The transceiver has not established a link to a network device. - The LEDs are turned off. To turn on the LEDs, use the eco-friendly button in the management panel or the NO ECOFRIENDLY LED command in the command line interface.

The LED states for breakout cables are described in Table 26.

Table 26. Link and Activity Status LEDs for 10Gbps Breakout Cables

State	Description
Solid Amber	At least one of the four ports on the breakout cable has established a 10Gbps link to a network device.
Flashing Amber	At least one of the four ports on the breakout cable is sending or receiving data.
Off	<p>Possible causes of this state are listed here:</p> <ul style="list-style-type: none"> - The transceiver slot is empty. - None of the ports on the breakout cable have established a link to a network device. - The LEDs are turned off. To turn on the LEDs, use the eco-friendly button in the management panel or the NO ECOFRIENDLY LED command in the command line interface.

XEM2-1CQ Line Card

The XEM2-1CQ Line Card is shown in Figure 27.

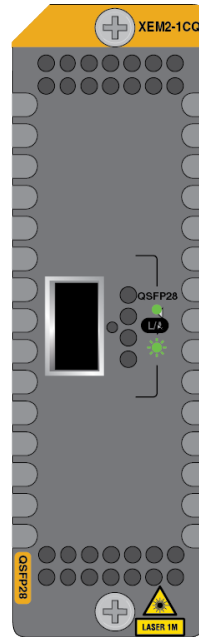

Figure 27. XEM2-1CQ Line Card

Transceiver Port

The one port on the card supports the following 100Gbps QSFP28 transceivers:

- ❑ QSFP28SR4 transceiver - Maximum operating distance of 70m (230 ft) or 100m (328 ft) with 12-strand OM3 or OM4 fiber optic cable, respectively. Requires a MPO pluggable optical connector.
- ❑ QSFP28LR4 transceiver - Operating range of 2m (6.6 ft) to 10km (6.2 mi). Requires single-mode fiber optic cable with a duplex LC connector.
- ❑ QSFP28-1CU and QSFP28-3CU direct attach cables - Lengths of one and three meters, respectively.

LEDs

The LED states for the port in the XEM2-1CQ Line Card are described in Table 27 on page 64.

Table 27. Port Link and Activity Status LED on the XEM2-1CQ Line Card

State	Description
Solid Green	The transceiver has established a link to a network device.

Table 27. Port Link and Activity Status LED on the XEM2-1CQ Line Card

State	Description
Flashing Green	The transceiver is transmitting or receiving data.
Off	<p>Possible causes of this state are listed here:</p> <ul style="list-style-type: none"> - The transceiver slot is empty. - The transceiver has not established a link to a network device. - The LEDs are turned off. To turn on the LEDs, use the eco-friendly button in the management panel or the NO ECOFRIENDLY LED command in the command line interface.

Chapter 3

Beginning the Installation

The chapter contains the following sections:

- “Reviewing Safety Precautions” on page 68
- “Installation Options” on page 73
- “Choosing a Site for the Chassis” on page 74
- “Unpacking the Switch” on page 75
- “Verifying the Accessory Kit” on page 79
- “Unpacking the PWR600 AC Power Supply” on page 81
- “Unpacking the PWR600 DC Power Supply” on page 84

Reviewing Safety Precautions

Please review the following safety precautions before beginning the installation procedure.

Note

Safety statements that have the  symbol are translated into multiple languages in the *Translated Safety Statements* document at www.alliedtelesis.com/support.



Warning

Class 1 Laser product.  L1



Warning

Laser Radiation.
Class 1M Laser product.  L10



Warning

Do not stare into the laser beam.  L2



Warning

Do not look directly at the fiber optic ends or inspect the cable ends with an optical lens.  L6



Warning

To prevent electric shock, do not remove the cover. No user-serviceable parts inside. This unit contains hazardous voltages and should only be opened by a trained and qualified technician. To avoid the possibility of electric shock, disconnect electric power to the product before connecting or disconnecting the LAN cables.
 E1



Warning

Do not work on equipment or cables during periods of lightning activity.  E2



Warning

Power cord is used as a disconnection device. To de-energize equipment, disconnect the power cord. ⚡ E3



Warning

Class I Equipment. This equipment must be earthed. The power plug must be connected to a properly wired earth ground socket outlet. An improperly wired socket outlet could place hazardous voltages on accessible metal parts. ⚡ E4

Note

Pluggable Equipment. The socket outlet shall be installed near the equipment and shall be easily accessible. ⚡ E5



Caution

Air vents must not be blocked and must have free access to the room ambient air for cooling. ⚡ E6



Warning

Operating Temperatures. This product is designed for a maximum ambient temperature of 50° degrees C. ⚡ E52

Note

All Countries: Install product in accordance with local and National Electrical Codes. ⚡ E8



Warning

Do not strip more than the recommended amount of wire. Stripping more than the recommended amount can create a safety hazard by leaving exposed wire on the terminal block after installation. ⚡ E10



Warning

When installing this equipment, always ensure that the frame ground connection is installed first and disconnected last. ⚡ E11



Warning

Only trained and qualified personnel are allowed to install or replace this equipment. ⚡ E14



Warning

The equipment must be earthed. The ground screw on the unit must be connected to a properly earthed bonding point. ⚡ E120



Caution

Circuit Overloading: Consideration should be given to the connection of the equipment to the supply circuit and the effect that overloading of circuits might have on overcurrent protection and supply wiring. Appropriate consideration of equipment nameplate ratings should be used when addressing this concern. ⚡ E21



Caution

Risk of explosion if battery is replaced by an incorrect type. Replace only with the same or equivalent type recommended by the manufacturer. Dispose of used batteries according to the manufacturer's instructions.

Attention: Le remplacement de la batterie par une batterie de type incorrect peut provoquer un danger d'explosion. La remplacer uniquement par une batterie du même type ou de type équivalent recommandée par le constructeur. Les batteries doivent être éliminées conformément aux instructions du constructeur. ⚡ E22



Warning

Mounting of the equipment in the rack should be such that a hazardous condition is not created due to uneven mechanical loading. ⚡ E25



Warning

The chassis may be heavy and awkward to lift. Allied Telesis recommends that you get assistance when mounting the chassis in an equipment rack. ⚡ E28

Note

Use dedicated power circuits or power conditioners to supply reliable electrical power to the device. ⚡ E27

**Warning**

This unit might have more than one power cord. To reduce the risk of electric shock, disconnect all power cords before servicing the unit. ⚡ E30

Note

If installed in a closed or multi-unit rack assembly, the operating ambient temperature of the rack environment may be greater than the room ambient temperature. Therefore, consideration should be given to installing the equipment in an environment compatible with the manufacturer's maximum rated ambient temperature (T_{mra}). ⚡ E35

**Caution**

Installation of the equipment in a rack should be such that the amount of air flow required for safe operation of the equipment is not compromised. ⚡ E36

**Warning**

Reliable earthing of rack-mounted equipment should be maintained. Particular attention should be given to supply connections other than direct connections to the branch circuits (e.g., use of power strips). ⚡ E37

**Warning**

This product may have multiple AC power cords installed. To de-energize this equipment, disconnect all power cords from the device. ⚡ E41

**Caution**

An Energy Hazard exists inside this equipment. Do not insert hands or tools into open chassis slots or plugs. ⚡ E44



Warning

This equipment shall be installed in a Restricted Access location.
E45



Caution

The unit does not contain serviceable components. Please return damaged units for servicing. E42



Warning

The temperature of an operational SFP or SFP+ transceiver may exceed 70° C (158° F). Exercise caution when removing or handling transceivers with unprotected hands. E43



Warning

The AC power supply unit must be connected to a grounded three wire AC source through the power supply cord. E127

Installation Options

Here are installation options for the x950 series switches:

- ❑ The x950-28XSQ and x950-28XTQm switches can have an XEM2 line card installed. Refer to “Installing an Optional XEM2 Ethernet Line Card” on page 101.
- ❑ The switch has four orientation options. Refer to Figure 28.

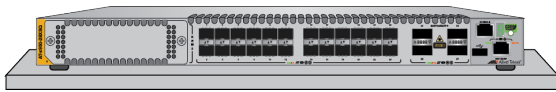

Tabletop

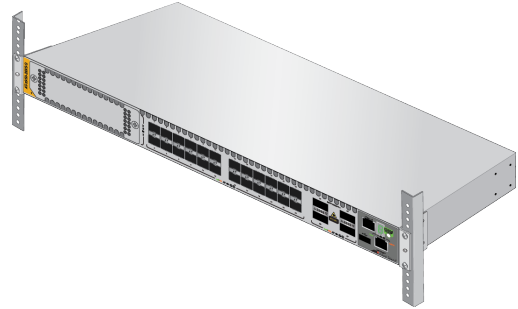

19-inch Equipment Rack with Standard Brackets

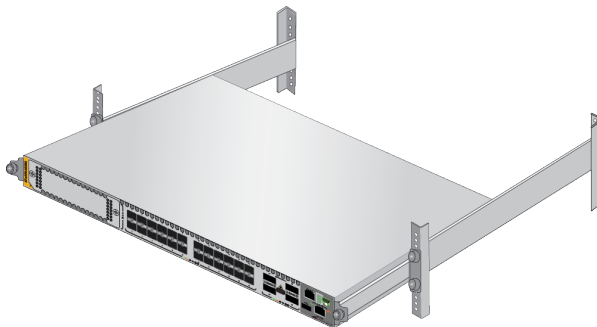

19-inch Equipment Rack with Optional RKMT-SL01 Sliding Rack Mount Kit

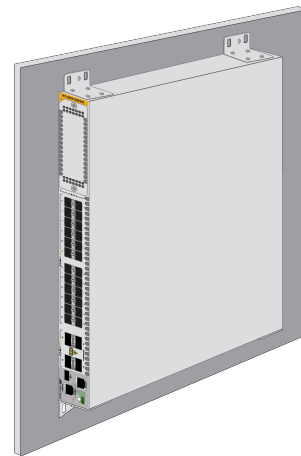

Wall Installation with Standard Brackets

Figure 28. Installation Options

- ❑ The switch can be installed into an equipment rack using the RKMT-SL01 sliding rack mount kit. Refer to Chapter 8, “Installing the Switch in the RKMT-SL01 Sliding Rack” on page 133.

Note

The standard brackets are included with the switch, The optional RKMT-SL01 Sliding Rack is purchased separately.

Choosing a Site for the Chassis

Observe these site requirements.

- ❑ If you are installing the device in an equipment rack, check that the rack is safely secured so that it will not tip over. Devices should be installed in the rack starting at the bottom, with the heavier devices near the bottom of the rack.
- ❑ The power outlet should be located near the chassis and be easily accessible.
- ❑ The site should allow for easy access to the ports on the front of the switch, so that you can easily connect and disconnect cables, and view the port LEDs.
- ❑ The site should allow for adequate air flow around the unit and through the cooling vents on the front and rear panels. (The ventilation direction is from front to back, with the fans on the back panel drawing the air out of the unit.)
- ❑ The site should not expose the switch to moisture or water.
- ❑ The site should be a dust-free environment.
- ❑ The site should include dedicated power circuits or power conditioners to supply reliable electrical power to the network devices.
- ❑ Twisted pair cabling should not be exposed to sources of electrical noise, such as radio transmitters, broadband amplifiers, power lines, electric motors, or fluorescent fixtures.
- ❑ Switch ports are suitable for intra-building connections, or where non-exposed cabling is required.
- ❑ Do not install the device in a wiring or utility box that has inadequate airflow because it might overheat and fail.

Unpacking the Switch

To unpack the switch from its shipping box, perform the following procedure:

1. Remove the accessories and documents from the accessory box partition. Refer to Figure 29.

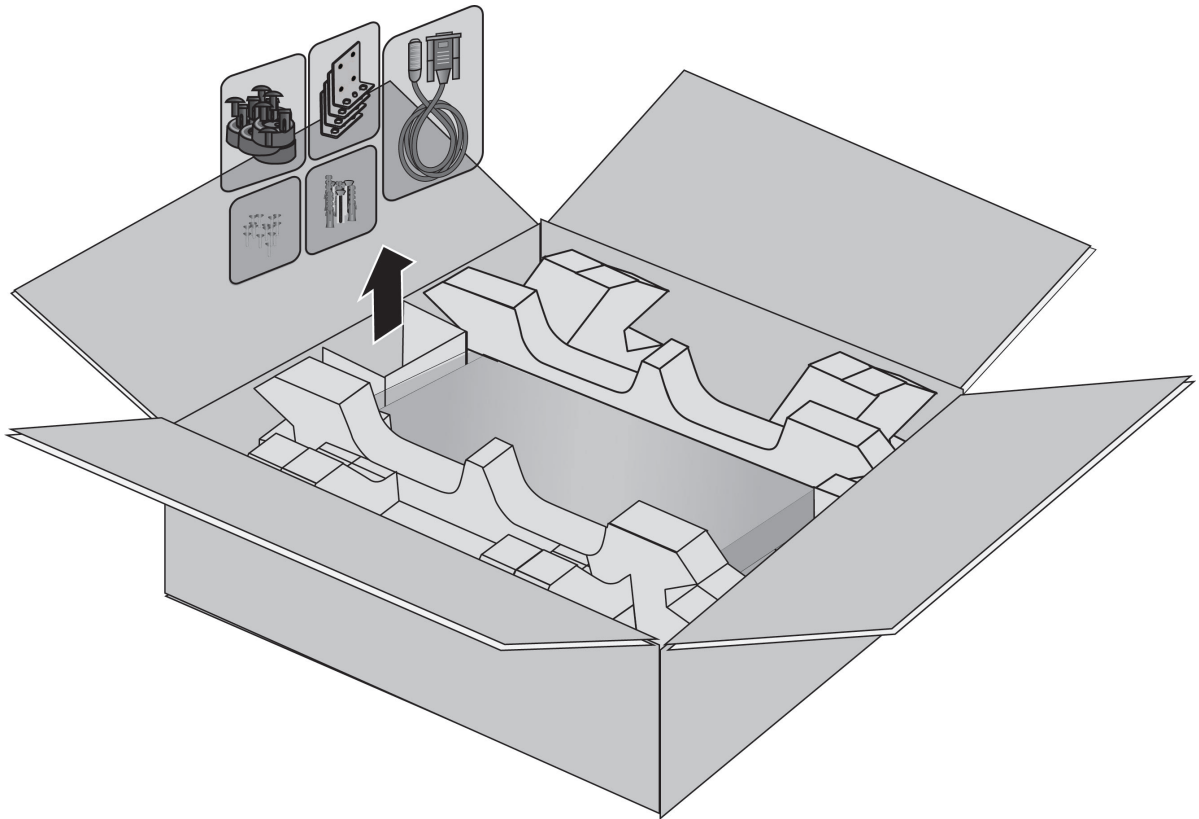

Figure 29. Removing Accessories

2. Remove the accessory box partition. Refer to Figure 30 on page 76.

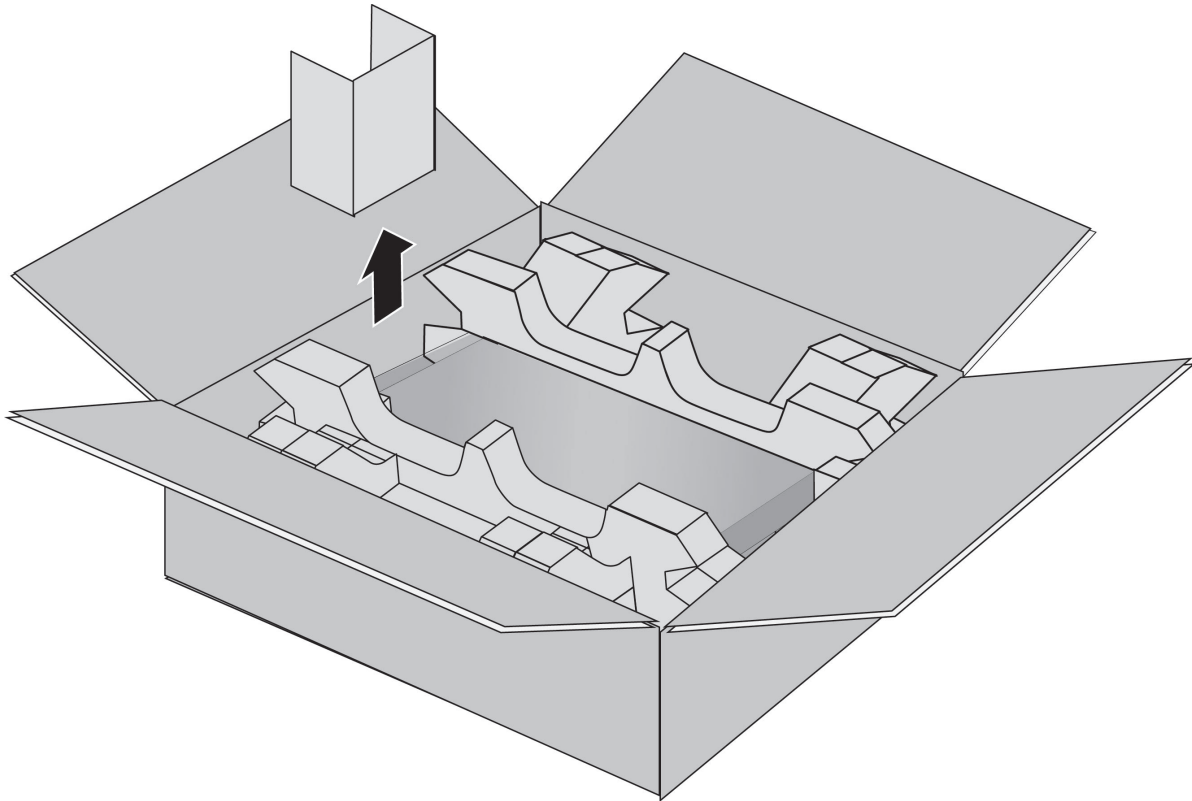

Figure 30. Removing the Shipping Box Partition

3. Lift the switch from the shipping box and place it on a level, secure table. Refer to Figure 31 on page 77.



Warning

The device is heavy. Always ask for assistance before moving or lifting it to avoid injure yourself or damage the equipment. *GE* E122

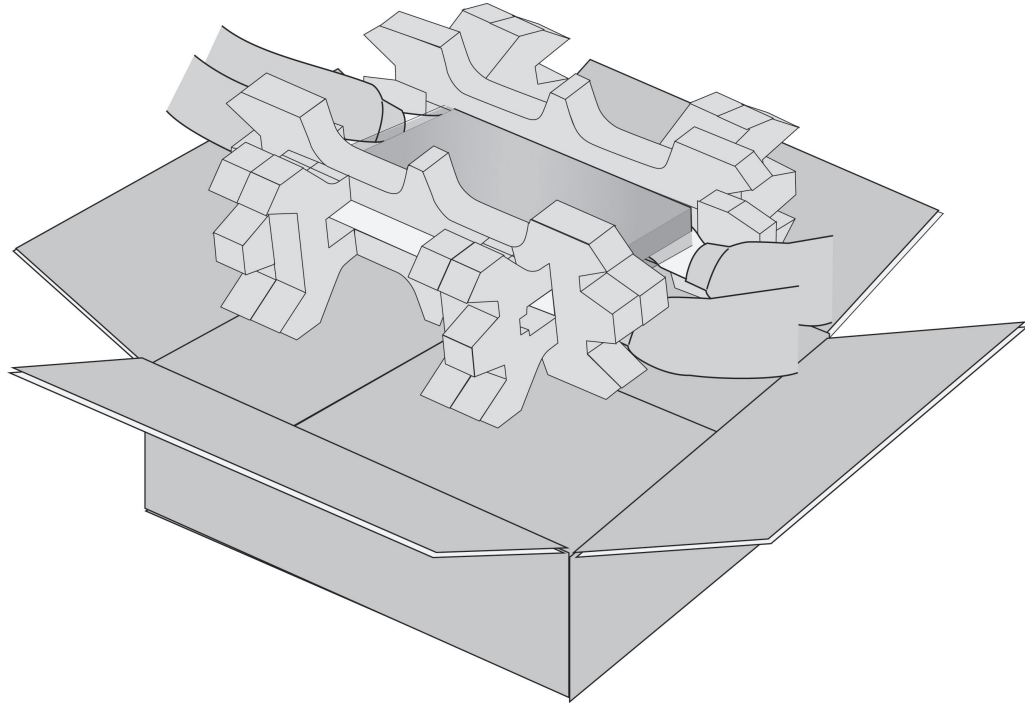

Figure 31. Lifting the Switch from the Shipping Box

4. Remove the switch from the shipping end-caps and protective bag. Refer to Figure 32.

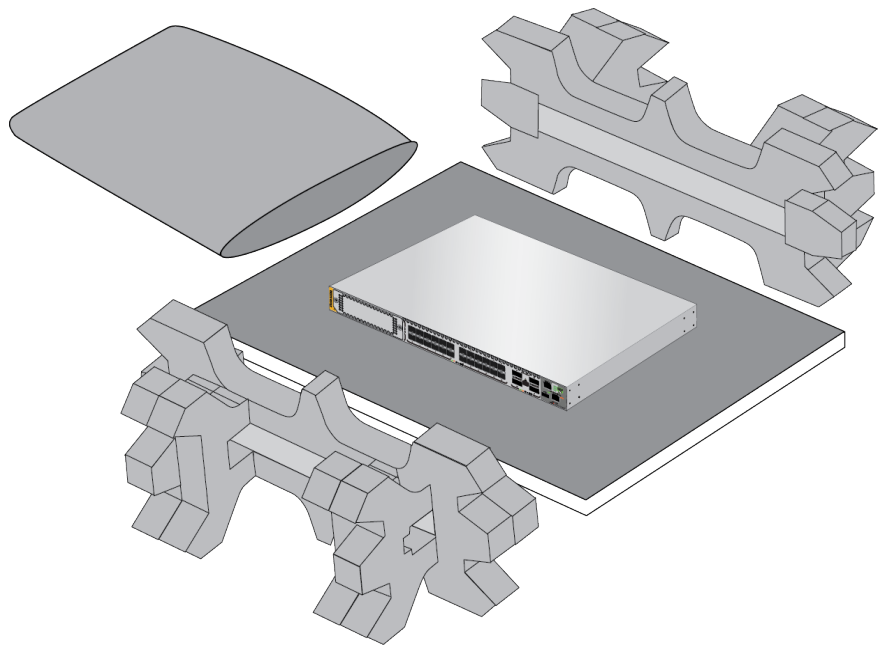

Figure 32. Removing the Switch from the Shipping End-caps and Protective Bag

5. Visually inspect the product for damage.
6. Visually inspect the front panel for the components shown in Figure 1 on page 14.
7. Verify that there are two pre-installed fan modules in FAN A and FAN B slots on the rear panel. Refer to Figure 3 on page 15 and “FAN05 Cooling Fan” on page 41.

Note





Do not power on the switch if it is missing a fan module.

8. Go to “Verifying the Accessory Kit” on page 79.

Verifying the Accessory Kit

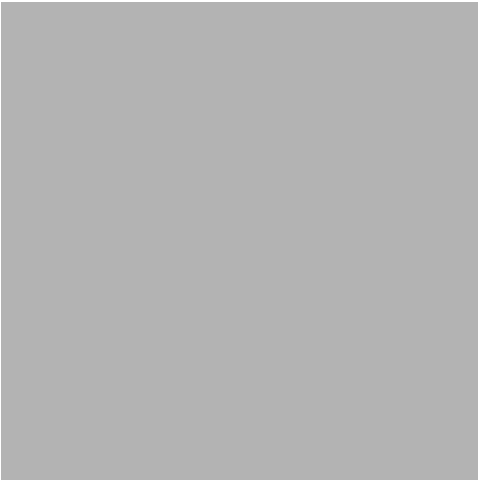

Table 28 lists the accessory items that are included with the switch.

Table 28. Accessory Kit

Item	Description
	One 2 m (6.6 ft) local management cable with RJ-45 (8P8C) and DB-9 (D-sub 9-pin) connectors.
	<p>Four standard mounting brackets</p> <hr/> <p>Note For the x950-28XSQ and x950-28XTQm switches, these brackets are for both equipment rack and wall mounting.</p> <hr/> <p>Note For the x950-52XSQ and x950-52XTQm switches, these brackets are only for wall mounting. For equipment rack mounting, use the rack mounting brackets shown in Table 29 on page 80.</p>
	Sixteen M3x6mm screws for the standard mounting brackets
	Four anchors for concrete walls: Length: 29.6mm (1.2 in.) Diameter: 4mm (0.2 in.)
	Four screws for wood or concrete walls: Length: 32.6mm (1.3 in.) Diameter: 4mm (0.2 in.)
	Seven bumper feet

In addition to the accessory kit listed in Table 28 on page 79, the x950-52XSQ and x950-52XTQm switches are shipped with the rack mounting brackets and screws as shown in Table 29.

Table 29. Additional Accessory Kit for the x950-52XSQ and x950-52XTQm Switches

Item	Description
	Two rack mounting brackets for the x950-52XSQ and x950-52XTQm switches
	Eight M4x7mm screws for the rack mounting brackets

Note

If any item is missing or damaged, contact your Allied Telesis sales representative for assistance.

After unpacking the switch and verifying the accessory kit, go to “Unpacking the PWR600 AC Power Supply” on page 81 or “Unpacking the PWR600 DC Power Supply” on page 84.

Unpacking the PWR600 AC Power Supply

To unpack the PWR600 AC Power Supply, perform the following procedure:

1. Remove the power cord and any documents from the accessory box partition. Refer to Figure 33.

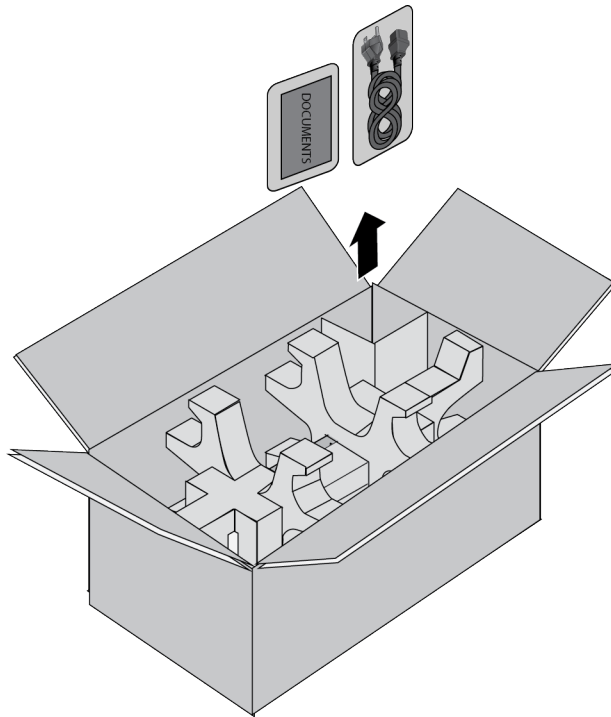

Figure 33. Removing the Power Cord and Documents from the PWR600 AC Power Supply

2. Remove the partition from the shipping box. Refer to Figure 34 on page 82.

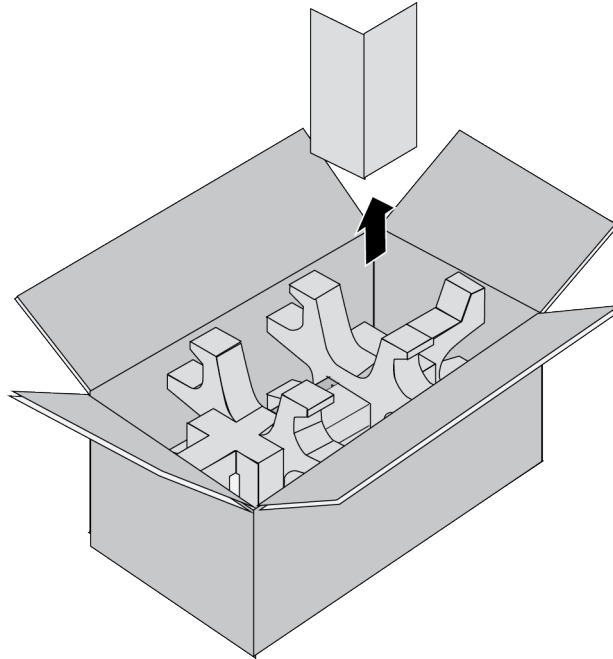

Figure 34. Removing the Partition from the PWR600 AC Power Supply Shipping Box

3. Lift the AC power supply from the shipping box and place it on a level, secure table. Refer to Figure 35 on page 83.



Warning

The device is heavy. Always ask for assistance before moving or lifting it to avoid injure yourself or damage the equipment. *GE* E122

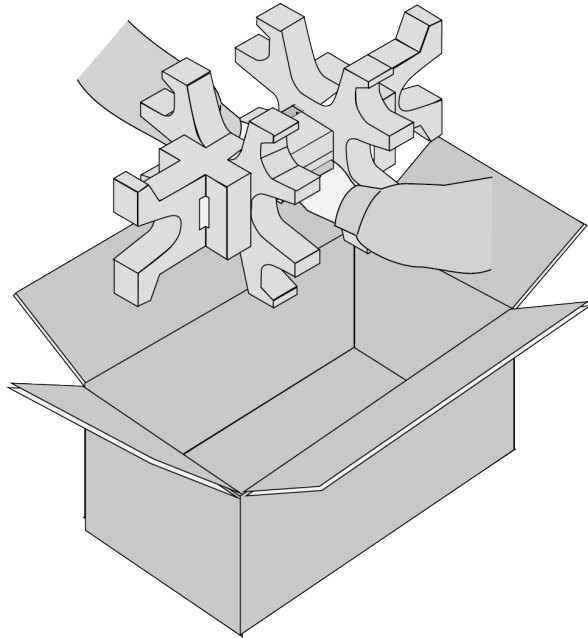

Figure 35. Removing the Power Supply from the Shipping Box

4. Remove the power supply from the shipping end-caps and protective shipping bag. Refer to Figure 36.

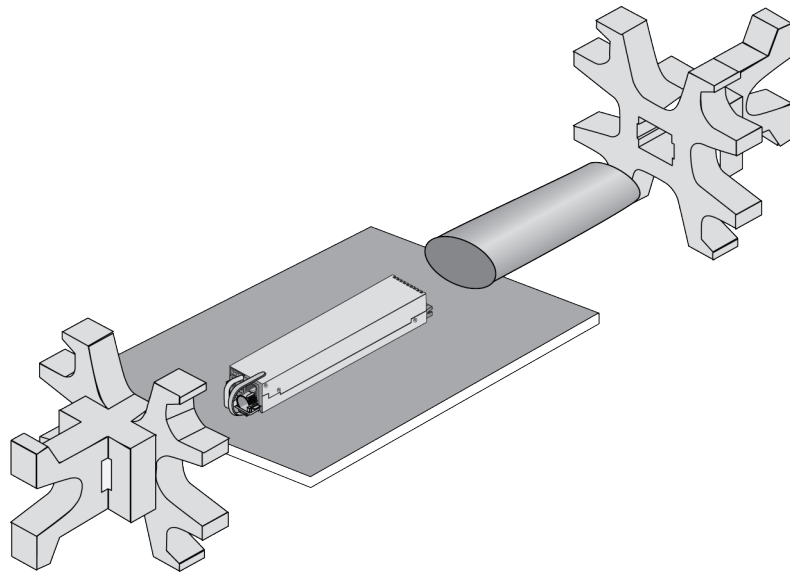

Figure 36. Removing the Power Supply from the Shipping End-caps and Protective Bag

5. Visually inspect the product for damage.
6. After unpacking the switch and power supplies, go to Chapter 4, “Installing Power Supplies and Optional XEM2 Line Card” on page 85.

Unpacking the PWR600 DC Power Supply

To unpack the PWR600 DC Power Supply, perform the following procedure:

1. Open the box and remove the PWR600 DC power supply.
2. Visually inspect the product for damage.
3. After unpacking the switch and power supplies, go to “Installing PWR600 DC Power Supplies” on page 90.

Chapter 4

Installing Power Supplies and Optional XEM2 Line Card

This chapter has the following procedures:

- ❑ “Installing PWR600 AC Power Supplies” on page 86
- ❑ “Installing PWR600 DC Power Supplies” on page 90
- ❑ “Connecting the Grounding Wire” on page 93
- ❑ “Connecting the DC Power Wires” on page 97
- ❑ “Installing an Optional XEM2 Ethernet Line Card” on page 101

Installing PWR600 AC Power Supplies

This section contains the procedure for installing PWR600 AC Power Supplies in the switch. For background information, refer to “PWR600 AC and DC Power Supplies” on page 36. For a list of power supply components, refer to “Unpacking the PWR600 AC Power Supply” on page 81.



Warning

The device is heavy. Use both hands to lift it. You might injure yourself or damage the device if you drop it. *⚡* E94



Caution

The electronic components on the device can be damaged by electrostatic discharge (ESD). Follow the procedure in “Protecting Against Electrostatic Discharge (ESD)” to guard against ESD damage when unpacking or installing the device. *⚡* E106

To install a power supply, perform the following procedure:

1. Choose a slot for the power supply. The two power supply slots are labeled PSU A and PSU B on the left side of the rear panel.

If you are installing only one power supply, you can install it in either slot. Allied Telesis recommends PSU A because that slot does not come with a blank power supply panel.

2. If there is already a power supply in PSU A, remove the blank panel from PSU B slot by pressing the release tab to the right and sliding the panel from the switch. Refer to Figure 37 on page 87.

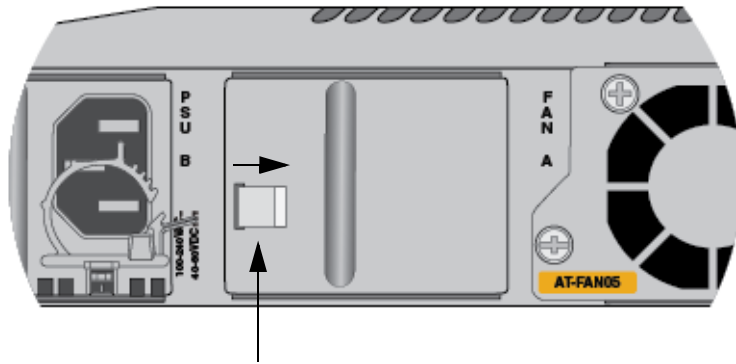

Release Tab

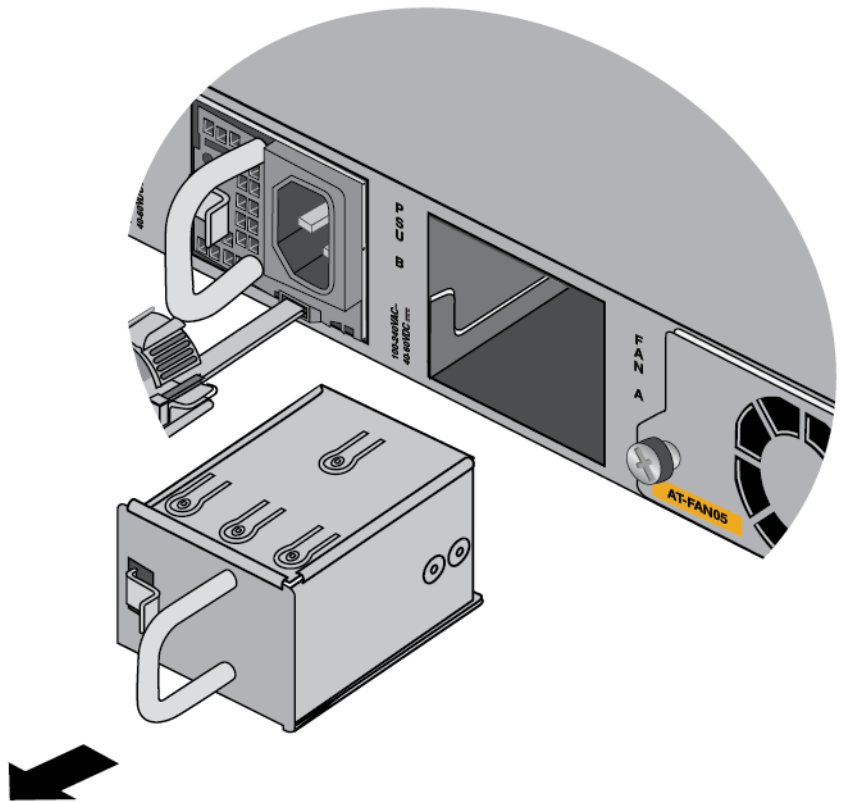

Figure 37. Removing the Blank Power Supply Panel from Slot PSU B

3. Carefully align the power supply in the slot and slide it into the slot. Figure 38 on page 88 shows the module aligned for the PSU A slot.

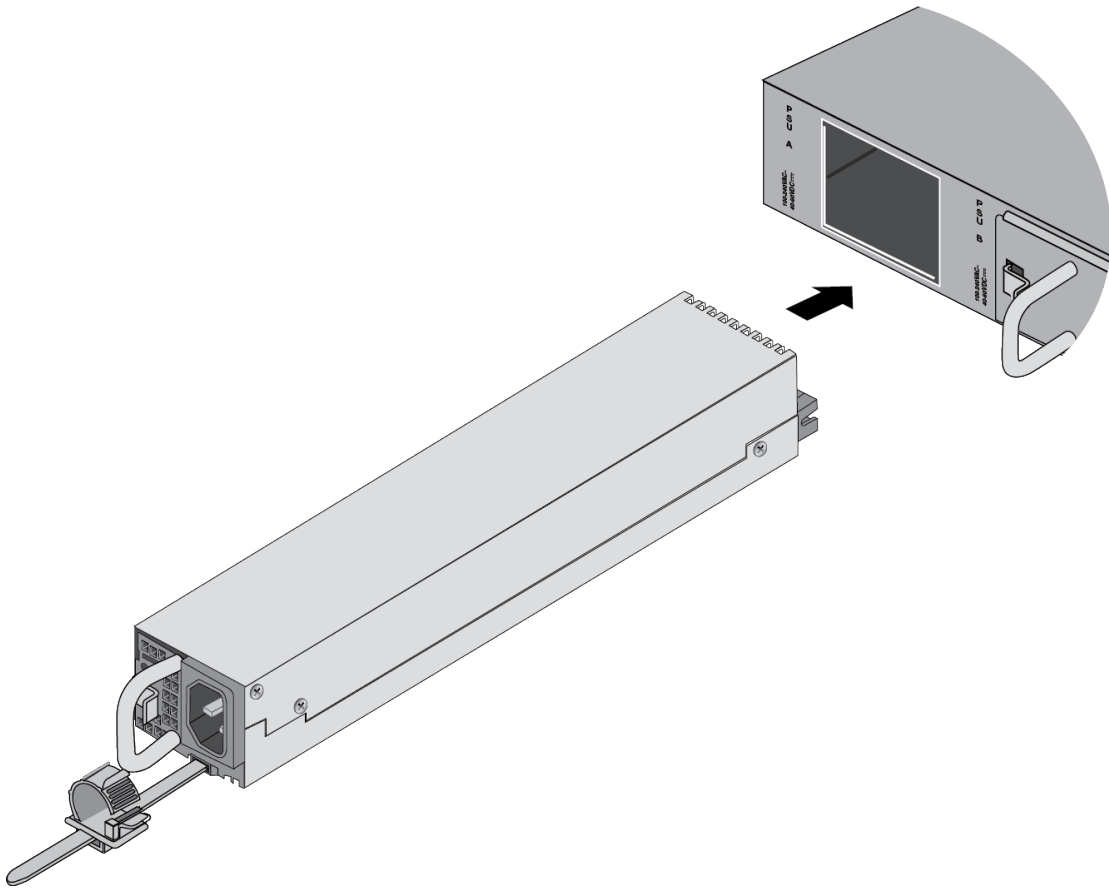

Figure 38. Sliding the PWR600 AC Power Supply into the Chassis

4. When the power supply makes contact with the connector inside the switch, gently press on its faceplate to seat it on the connector. Refer to Figure 39 on page 89.

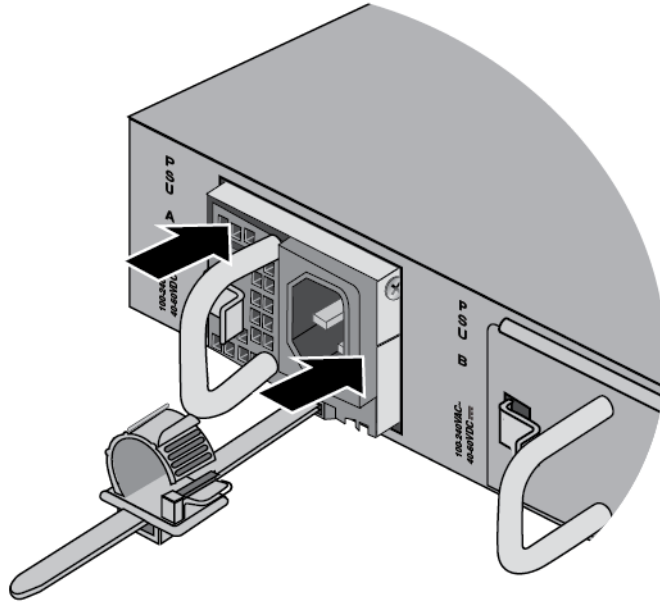

Figure 39. Seating the Power Supply on the Internal Connector

5. Visually inspect the power supply to be sure that its faceplate is flush against the rear panel of the chassis.
6. If you purchased two AC power supplies for the switch, repeat this procedure to install the second unit.
7. If you purchased a DC power supply as the second power supply, go to “Installing PWR600 DC Power Supplies” on page 90.
8. To install an optional XEM2 Ethernet Line Card, go to “Installing an Optional XEM2 Ethernet Line Card” on page 101.
9. After installing the power supplies and optional XEM2 Line Card, go to one of the following chapters:
 - ❑ Chapter 5, “Installing the Switch on a Table” on page 105
 - ❑ Chapter 6, “Installing the Switch in an Equipment Rack” on page 109
 - ❑ Chapter 7, “Installing the Switch on a Wall” on page 117
 - ❑ Chapter 8, “Installing the Switch in the RKMT-SL01 Sliding Rack” on page 133

Installing PWR600 DC Power Supplies

This section contains the procedure for installing PWR600 DC Power Supplies in the switch. For background information, refer to “PWR600 AC and DC Power Supplies” on page 36. For a list of power supply components, refer to “Unpacking the PWR600 DC Power Supply” on page 84.



Warning

The device is heavy. Use both hands to lift it. You might injure yourself or damage the device if you drop it.  E94



Caution

The electronic components on the device can be damaged by electrostatic discharge (ESD). Follow the procedure in “Protecting Against Electrostatic Discharge (ESD)” to guard against ESD damage when unpacking or installing the device.  E106

To install the PWR600 DC power supply, perform the following procedure:

1. Choose a slot for the power supply. The two power supply slots are labeled PSU A and PSU B on the left side of the rear panel.

If you are installing only one power supply, you can install it in either slot. Allied Telesis recommends PSU A because that slot does not come with a blank power supply panel.
2. If there is already a power supply in PSU A, remove the blank panel from PSU B slot by pressing the release tab to the right and sliding the panel from the switch. Refer to Figure 37 on page 87.
3. Carefully align the power supply in the slot and slide it into the slot. Figure 38 on page 88 shows the module aligned for the PSU A slot.

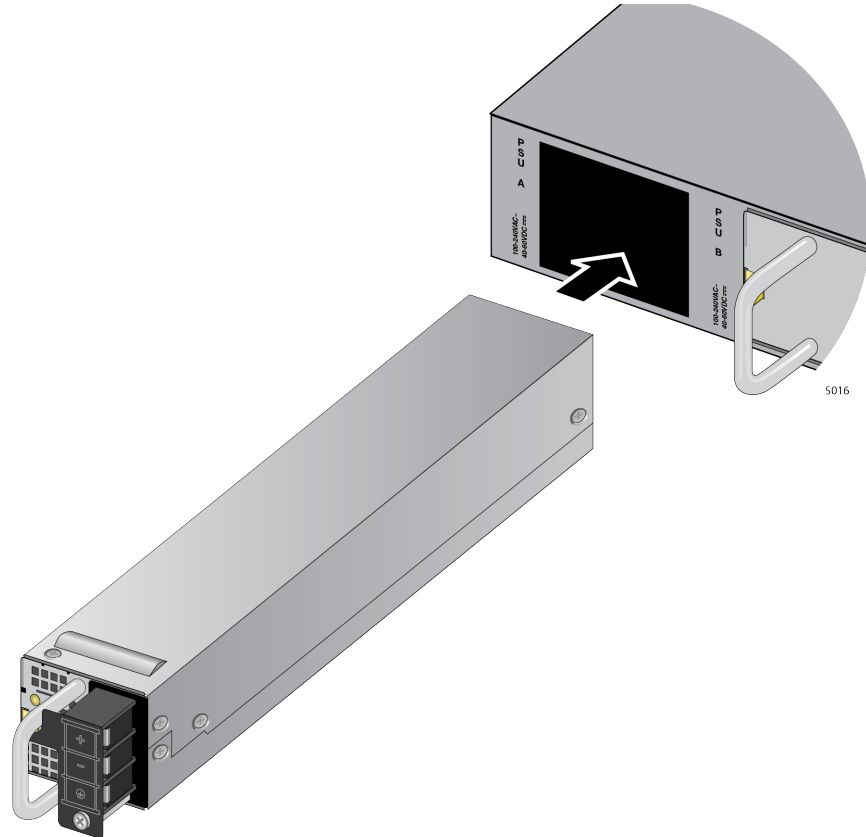

Figure 40. Sliding the PWR600 DC Power Supply into the Chassis

4. When the power supply makes contact with the connector inside the switch, gently press on its faceplate to seat it on the connector.
5. Visually inspect the power supply to be sure that its faceplate is flush against the rear panel of the chassis.
6. If you purchased two DC power supplies for the switch, repeat this procedure to install the second unit.
7. After installing the PWR600 DC power supply, go to the following sections:
 - ❑ “Connecting the Grounding Wire” on page 93
 - ❑ “Connecting the DC Power Wires” on page 97
8. If you purchased an AC power supply as the second power supply, go to “Installing PWR600 AC Power Supplies” on page 86.
9. To install an optional XEM2 Ethernet Line Card, go to “Installing an Optional XEM2 Ethernet Line Card” on page 101.

10. After installing the power supplies and optional XEM2 Line Card, go to one of the following chapters:
 - ❑ Chapter 5, “Installing the Switch on a Table” on page 105
 - ❑ Chapter 6, “Installing the Switch in an Equipment Rack” on page 109
 - ❑ Chapter 7, “Installing the Switch on a Wall” on page 117
 - ❑ Chapter 8, “Installing the Switch in the RKMT-SL01 Sliding Rack” on page 133

Connecting the Grounding Wire

Here are the guidelines for the grounding wire:

- The wire should be minimum #16 AWG solid wire.
- The wire length should be as short as possible.
- Continuity from the grounding screw to the earth ground must be less than 0.05 ohms.
- If a terminal is used, it should be double crimped.



Warning

The equipment must be earthed. The ground screw on the unit must be connected to a properly earthed bonding point. ⚡ E120



Warning

When installing this equipment, always ensure that the frame ground connection is installed first and disconnected last. ⚡ E11

The material and tools you need for connecting the ground wire:

- Minimum #16 AWG solid wire
- Wire insulation stripper
- Phillips-head screwdriver

To connect the grounding wire with bare wire, perform the following procedure:

1. Strip 2.54cm (1.0 in.) of insulation from the end of the solid grounding wire with a wire insulator stripper. Refer to Figure 41.

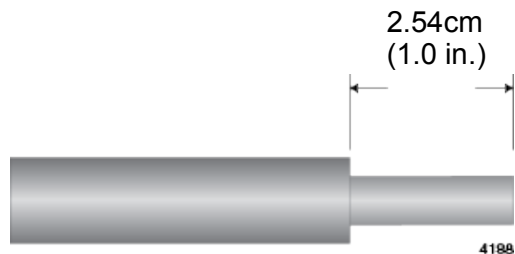



Figure 41. Stripping the Grounding Wire



Warning

Do not strip more than the recommended amount of wire. Stripping more than the recommended amount can create a safety hazard by leaving exposed wire on the terminal block after installation.  E10

2. Loosen the screw for the connector panel several turns with a Phillips-head screwdriver. Refer to Figure 42 on page 94.

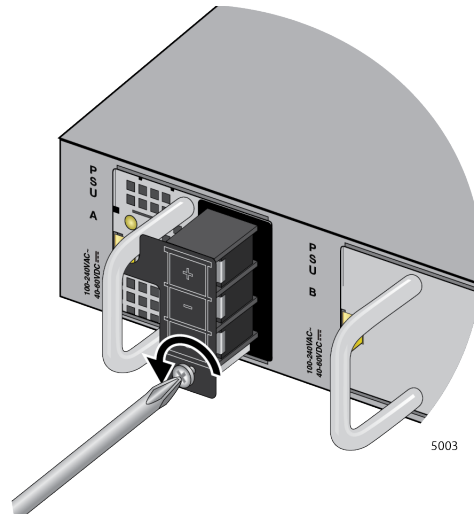

Figure 42. Loosening the Screw for the Panel

3. Press the panel to the right to expose the connectors as shown in Figure 43 on page 95.

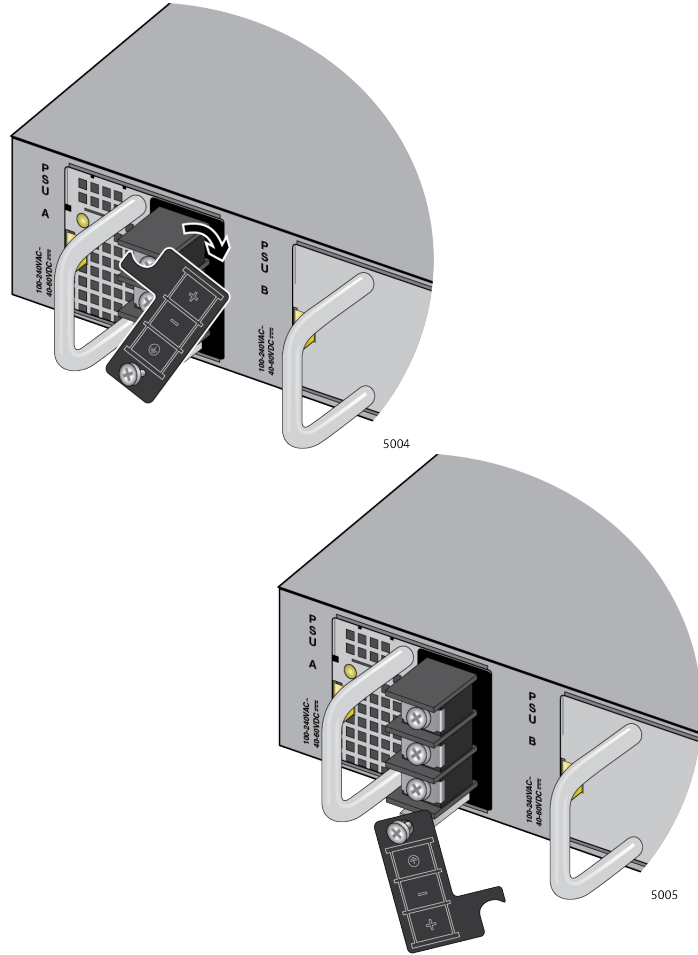

Figure 43. Accessing the Connectors

4. Loosen the ground screw with a Phillips-head screwdriver. Refer to Figure 44.

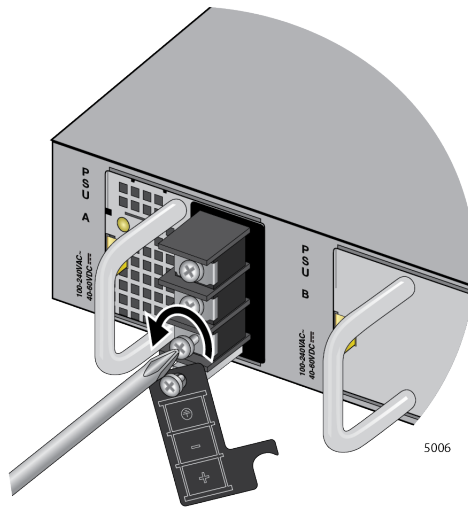

Figure 44. Loosening the Ground Screw

5. Wind the grounding wire clockwise around the base of the grounding screw. Refer to Figure 45.

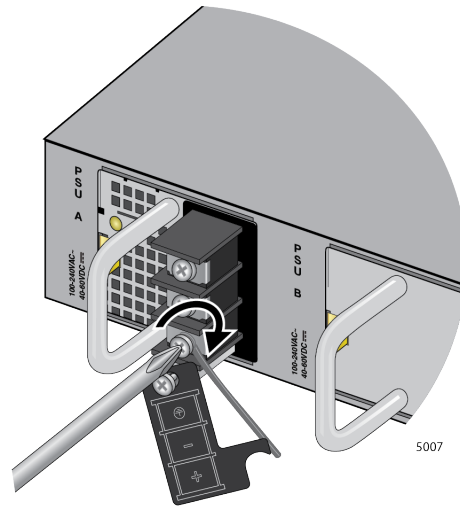

Figure 45. Wrapping the Grounding Wire and Tightening the Screw

6. Tighten the ground screw.
7. Connect the other end of the ground wire to a ground point at the installation site.
8. Go to “Connecting the Grounding Wire” on page 93.

Connecting the DC Power Wires

Here are the materials and tools for connecting the DC power cables:

- ❑ 18 AWG stranded wires. Do not use wire heavier than 16 AWG. solid wire.
- ❑ Wire insulation stripper
- ❑ Phillips-head screwdriver

To connect the DC power cables, perform the following procedure:

1. Strip 6.5mm (0.25 in.) of insulation from the end of the stranded power wires with a wire insulator stripper. Refer to Figure 43.

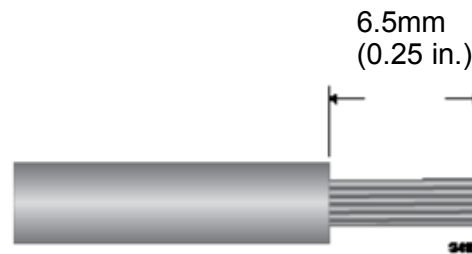

Figure 46. Stripping the Power Wire



Warning

Do not strip more than the recommended amount of wire. Stripping more than the recommended amount can create a safety hazard by leaving exposed wire on the terminal block after installation. ⚡ E10

2. Tightly wrap the wire strands with your finger tips.

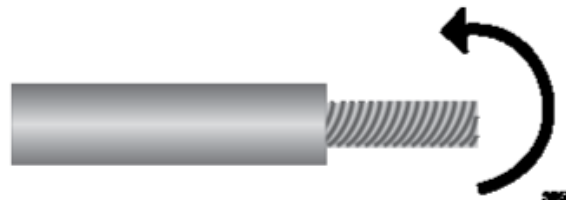

Figure 47. Wrapping the Wire Strands

This step is to prevent loose strands from touching other wires and causing an electrical short.

Note

Allied Telesis recommends tinning the wires with solder for added protection against loose strands. This guide does not provide instructions on how to tin wires.

3. Loosen the middle screw for the negative (-) with a Phillips-head screwdriver. Refer to Figure 48.

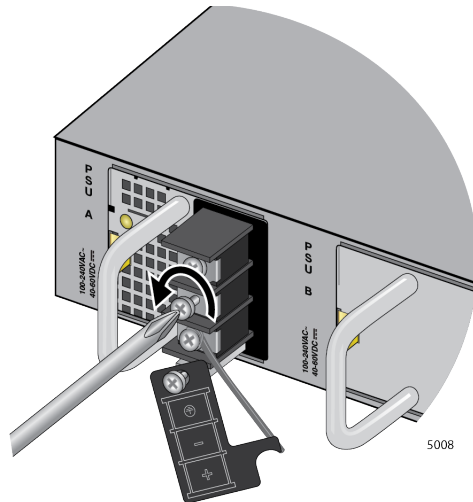

Figure 48. Loosening the Screw for the Negative (-)

4. Wind the power wire and tighten the screw. Refer to Figure 49.

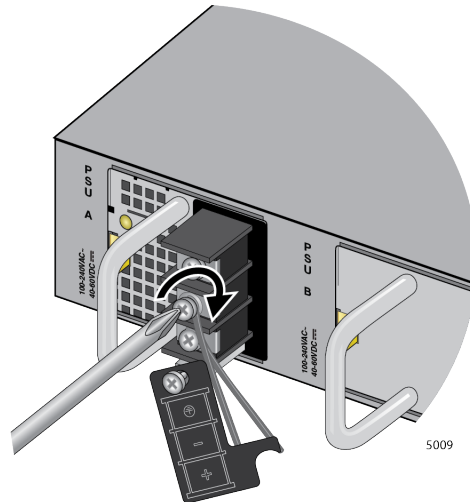

Figure 49. Tightening the Screw for the Negative (-)

- Loosen the top screw for the positive (+) with a Phillips-head screwdriver. Refer to Figure 50.

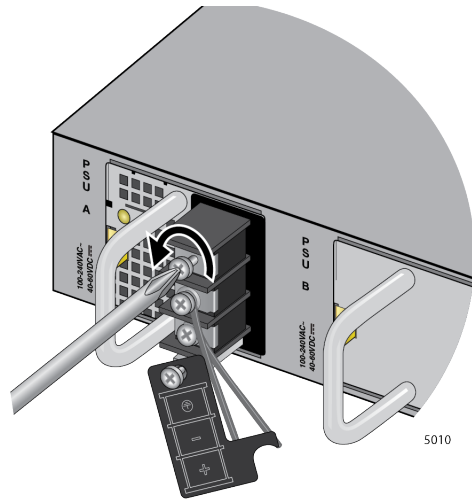

Figure 50. Loosening the Screw for the Negative (+)

- Wind the power wire and tighten the screw. Refer to Figure 51.

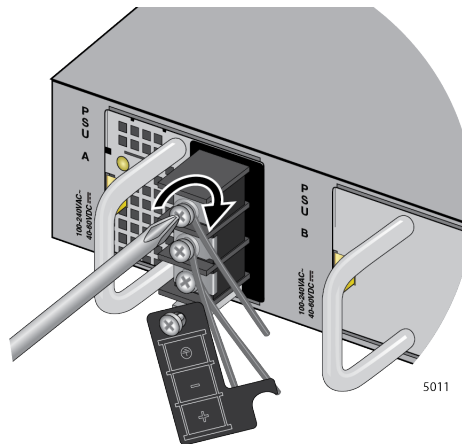

Figure 51. Tightening the Screw for the Negative (+)

- After attaching the wires to the screws, verify that there are no exposed wires or loose wire strands.



Warning

Check to see if there are any exposed copper strands coming from the installed wires. When this installation is done correctly there should be no exposed copper wire strands extending from the terminal block. Any exposed wiring can conduct harmful levels of electricity to persons touching the wires. ⚡ E12

8. Place the cover panel back to cover the connectors. Refer to Figure 52.

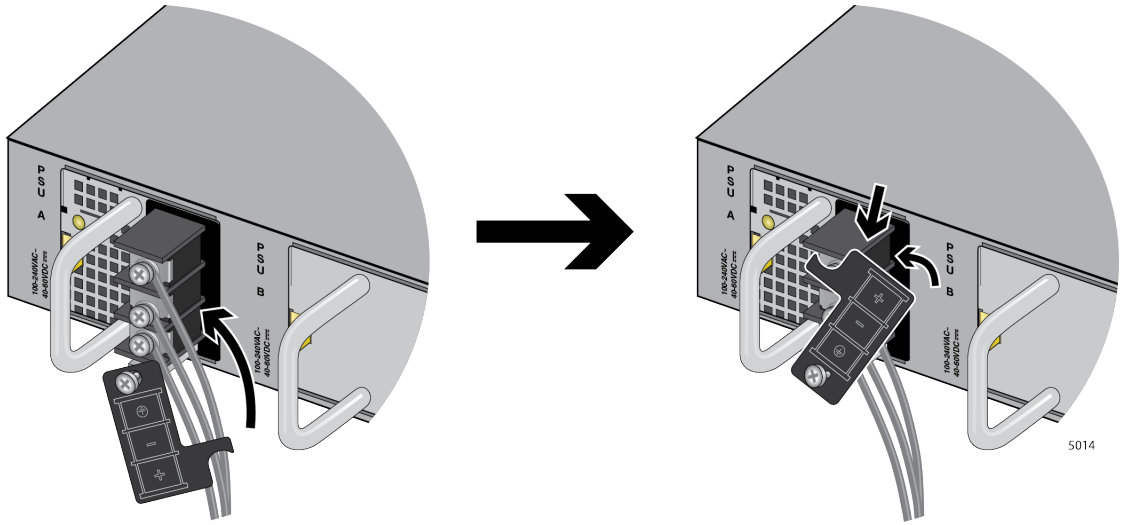

Figure 52. Placing the Cover Panel

9. Tighten the screw for the cover panel. Refer to Figure 53.

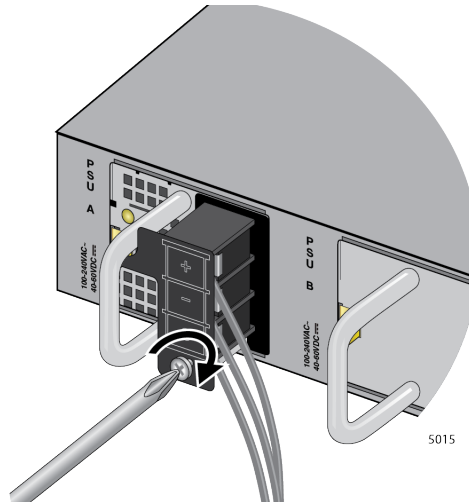

Figure 53. Tightening the Screw for the Cover Panel

Installing an Optional XEM2 Ethernet Line Card

This section contains the procedure for installing an optional XEM2 Ethernet line card in the expansion slot in the front panel of the x950-28XSQ or x950-28XTQm switch. For background information, refer to Chapter 2, “XEM2 Ethernet Line Cards” on page 47. The illustrations show the XEM2-12XT Line Card. The procedure is the same for all line cards.

Note

The x950-52XSQ and x950-52XTQm switches do *not* support the XEM2 line cards.



Caution

The device can be damaged by static electricity. Be sure to follow proper anti-static precautions when installing the device. Allied Telesis recommends using a properly grounded wrist strap or other personal anti-static device and an anti-static mat.

To install an XEM2 Ethernet line card, perform the following procedure:

1. Using a #2 Phillips-head screwdriver, loosen the two captive screws on the blank expansion slot panel and remove it from the switch. Refer to Figure 54.

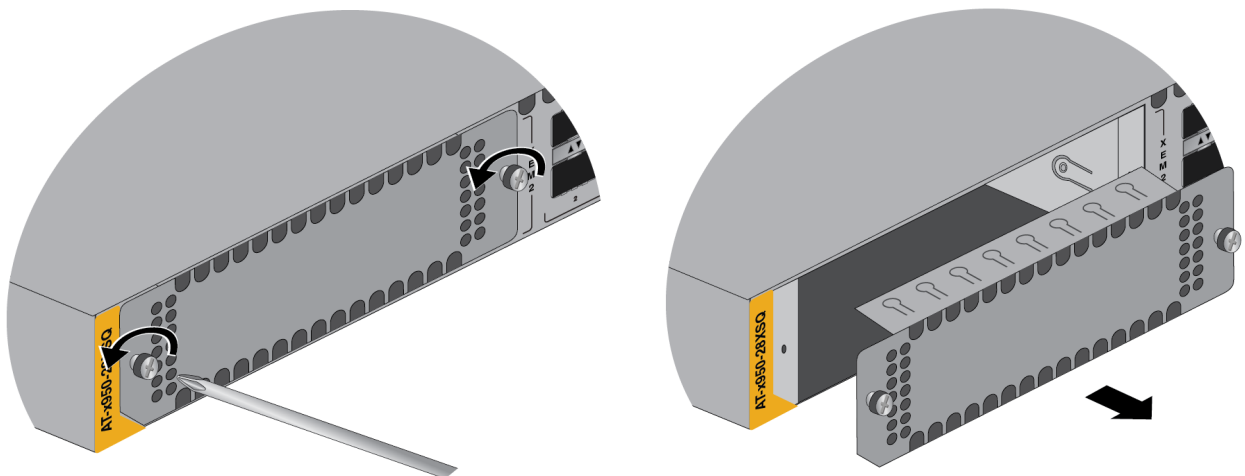

Figure 54. Removing the Blank Line Card Cover

2. Carefully remove the new Ethernet line card from its shipping container and anti-static bag. Refer to Figure 55 on page 102.



Figure 55. Removing the Ethernet Line Card from the Anti-static Bag

3. Position the line card with the notch on the faceplate in the bottom left corner, as shown in Figure 56, and carefully slide it into the slot.

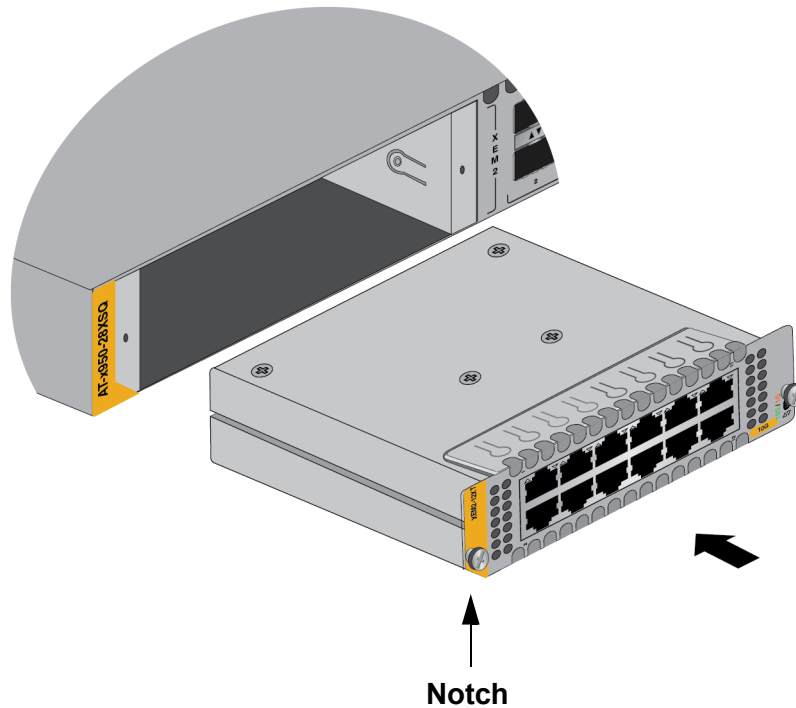

Figure 56. Sliding the Ethernet Line Card into the Slot



Caution

Do not use excessive force when seating the module, because this may damage the system or the module. If the module resists seating, remove it from the system, realign it, and try again. *E47*

4. When the line card makes contact with the internal connector in the switch, gently press on the sides of its faceplate to seat it on the connector. Refer to Figure 57.

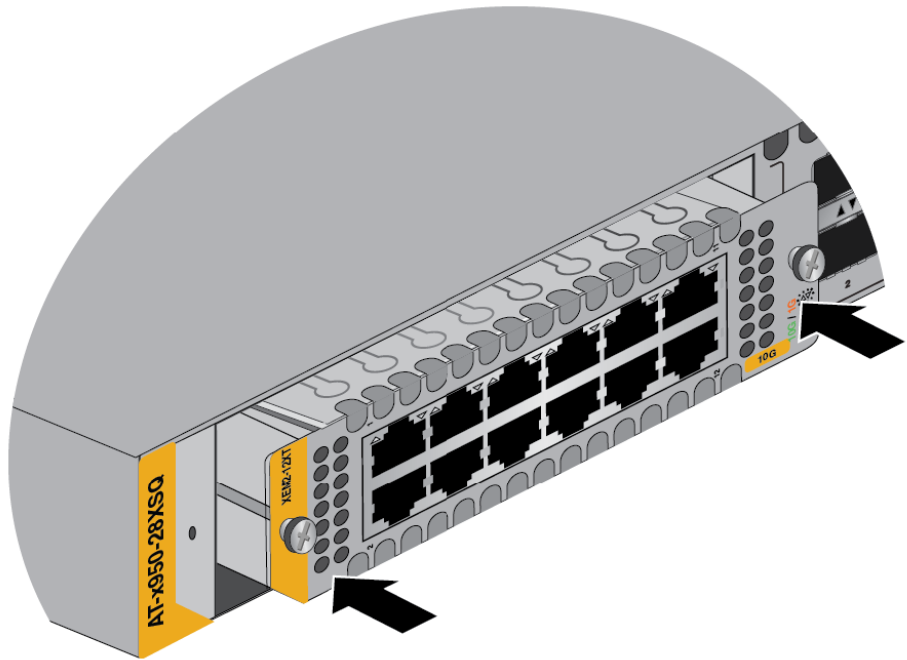

Figure 57. Seating the Ethernet Line Card in the Expansion Slot

5. Visually inspect the line card to verify that its faceplate is flush against the front panel of the chassis.
6. Tighten the two captive screws on the card to secure it in the switch. Refer to Figure 58 on page 104.

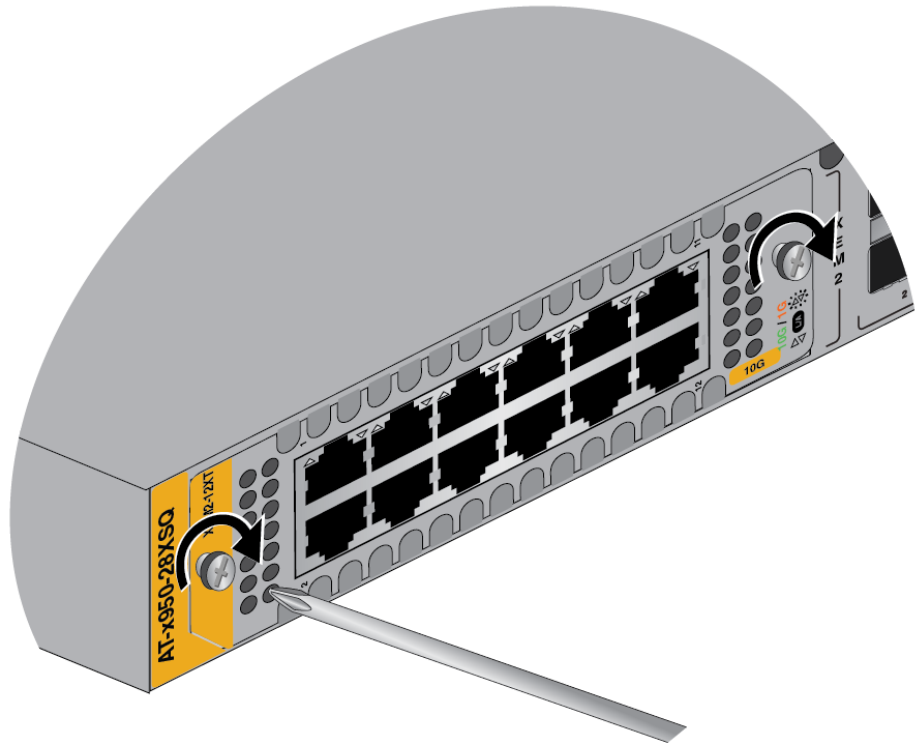

Figure 58. Tightening the Two Captive Screws on the Ethernet Line Card

7. After installing the power supplies and optional XEM2 Line Card, go to one of the following chapters:
 - Chapter 5, “Installing the Switch on a Table” on page 105
 - Chapter 6, “Installing the Switch in an Equipment Rack” on page 109
 - Chapter 7, “Installing the Switch on a Wall” on page 117
 - Chapter 8, “Installing the Switch in the RKMT-SL01 Sliding Rack” on page 133

Chapter 5

Installing the Switch on a Table

This chapter contains the instructions for installing the switch on a table or desktop.



Warning

Switches should not be stacked on a table or desktop. They could present a physical safety hazard if you need to move or replace switches. *E91*



Warning

The device is heavy. Always ask for assistance when moving or lifting it to avoid injuring yourself or damaging the equipment. *E122*

The switch comes with seven bumper feet in the accessory kit. The feet, which are reusable, are used when installing the switch on a table. If they are already assembled, disassemble them by removing the rivets and rivet housings from the bumper feet. Refer to Figure 59.

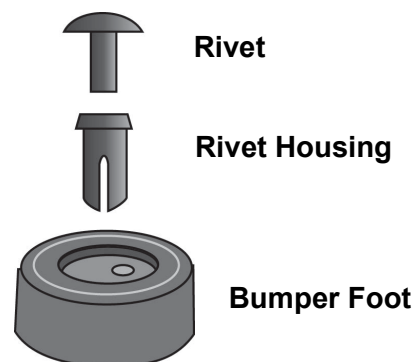

Figure 59. Parts of the Bumper Feet

The holes in the base of the switch for the bumper feet are shown in Figure 60 on page 106.

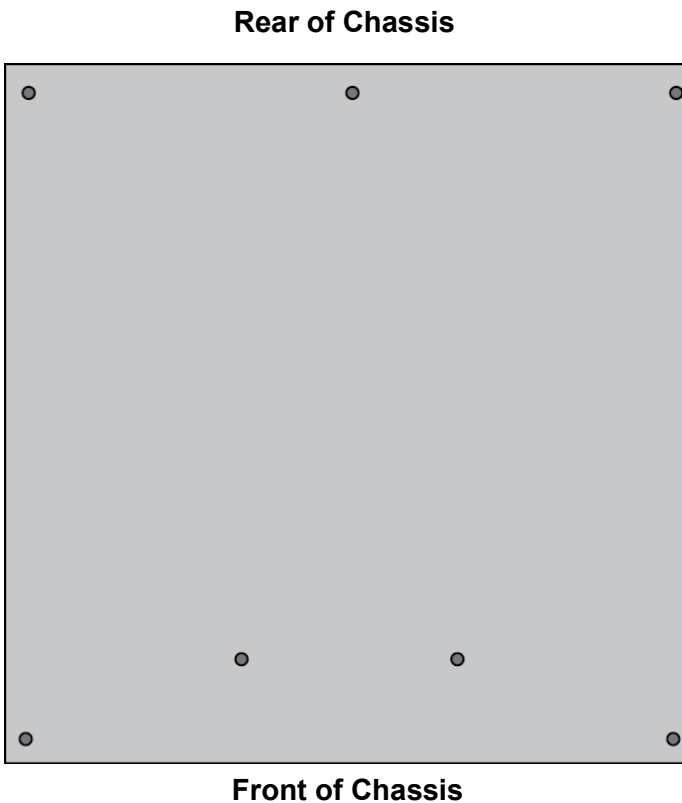

Figure 60. Holes for Bumper Feet

Note

The following procedure assumes that you have already reviewed the information and performed the procedures in Chapter 3, "Beginning the Installation" on page 67.

To install the switch on a table, perform the following procedure:

1. Place the switch upside down on a table.
2. Inset a rivet housing into a bumper foot. Refer to Figure 61.

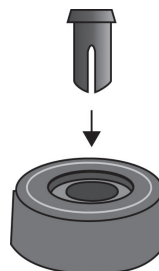

Figure 61. Inserting the Rivet Housing into the Bumper Foot

3. Place the bumper foot onto one of the holes in the base of the switch. Refer to Figure 62.

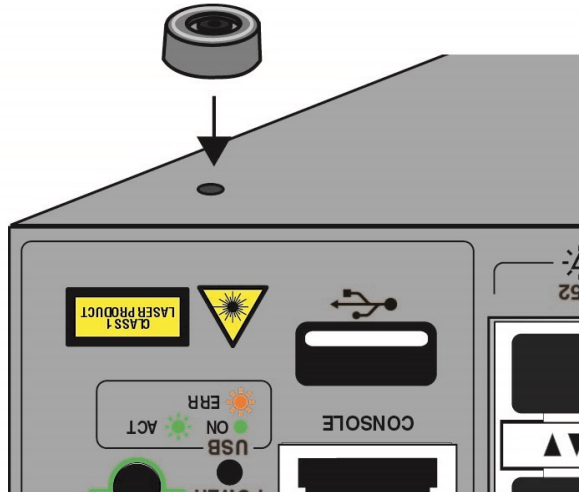

Figure 62. Placing the Bumper Foot on a Base Corner Hole

4. Insert the rivet to secure the bumper foot to the base. Refer to Figure 63.

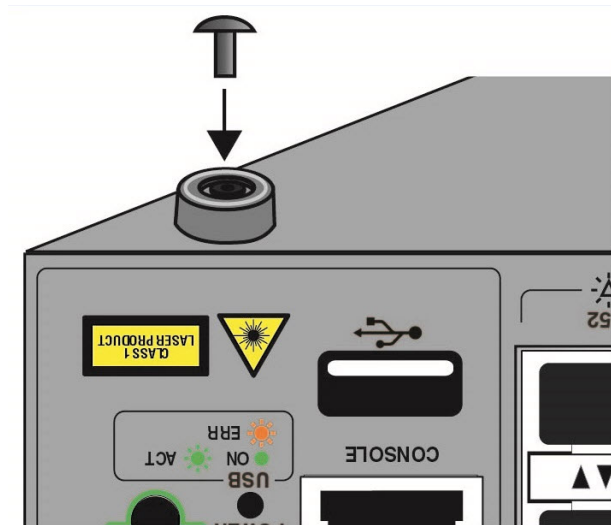

Figure 63. Inserting the Rivet into the Bumper Foot

5. Repeat steps 2 to 4 to install the remaining bumper feet.
6. Turn the switch over and place it on a flat, secure desk or table, leaving ample space around it for ventilation.

7. Do one of the following:
 - ❑ To install AC power supplies, go to “Installing PWR600 AC Power Supplies” on page 86.
 - ❑ To install DC power supplies, go to “Installing PWR600 DC Power Supplies” on page 90.
 - ❑ To install an optional XEM2 Ethernet Line Card, go to “Installing an Optional XEM2 Ethernet Line Card” on page 101.
 - ❑ If all the hardware components are installed, go to Chapter 9, “Verifying and Configuring the Switch” on page 157.

Chapter 6

Installing the Switch in an Equipment Rack

This chapter contains instructions for installing the switch in a standard 19-inch equipment rack. The procedures are listed here:

- ❑ “Beginning the Installation” on page 110
- ❑ “Removing the Bumper Feet” on page 112
- ❑ “Installing the Switch” on page 113

Beginning the Installation

This chapter contains the procedure for installing the switch in a standard 19-inch equipment rack, with the brackets included with the unit.

Required Items

The following items are required to install the switch in an equipment rack:

- ❑ Two equipment rack brackets (included with the switch)
- ❑ Eight M4x6mm bracket screws (included with the switch)
- ❑ Cross-head screwdriver (not provided)
- ❑ Four standard equipment rack screws (not provided)

Switch Orientations in the Equipment Rack

Figure 64 identifies the holes for the standard brackets on the x950-28XSQ and x950-28XTQm switches.



Figure 64. Holes for the Equipment Rack Brackets on the x950-28XSQ and x950-28XTQm Switches

Figure 65 identifies the holes for the equipment rack brackets on the x950-52XSQ and x950-52XTQm switches.



Figure 65. Holes for the Equipment Rack Brackets on the x950-52XSQ and x950-52XTQm Switches

You can install the switch with its front panel flush with or extending in front of the equipment rack. The illustrations in Figure 66 show the possible switch orientations in the equipment rack.



Figure 66. Switch Orientations in an Equipment Rack

Removing the Bumper Feet

The bumper feet included with the switch should not be used when installing the device in an equipment rack. If they are already installed, perform the following procedure to remove them:

1. Place the switch upside down on a level, secure surface.
2. Use a small flat-head screwdriver to gently pry the feet from the bottom of the switch. Refer to Figure 67.

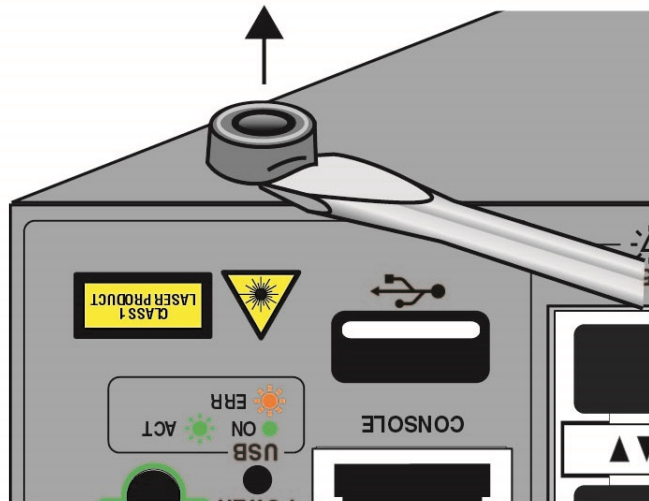

Figure 67. Removing the Bumper Feet

3. Turn the switch back over.
4. Go to “Installing the Switch” on page 113.

Installing the Switch

Please review the information and perform the procedures in Chapter 3, “Beginning the Installation” on page 67 before installing the switch.



Caution

The chassis may be heavy and awkward to lift. Allied Telesis recommends that you get assistance when mounting the chassis in an equipment rack. *See* E28

Note

The switch can be installed in an equipment rack with the RKMT-SL01 Sliding Rack Mount Kit. For instructions, refer to the *RKMT-SL01 Sliding Rack Mount Kit Installation Guide*.

Note

The switch comes with four brackets. Installing the device in an equipment rack requires only two brackets. All four brackets are used when installing the switch on a wall.

To install the switch in a 19-inch equipment rack, perform the following procedure:

1. Place the unit on a level, secure surface.
2. If you have not chosen an orientation for the switch in the equipment rack, review “Switch Orientations in the Equipment Rack” on page 110.
3. Attach two rack mount brackets to the sides of the switch in the selected positions as shown in Figure 68 on page 114. The illustration in Figure 69 on page 114 shows the installation of the brackets so that the front panel is even with the front of the equipment rack.
 - ❑ For the x950-28XSQ and x950-28XTQm switches, use two of the four standard brackets with eight of the M3x6mm screws listed in Table 28 on page 79.
 - ❑ For the x950-52XSQ and x950-52XTQm switches, use two rack mounting brackets with the eight M4x7mm screws listed in Table 29 on page 80.



Figure 68. Attaching the Equipment Rack Brackets

4. Have another person hold the switch in the equipment rack while you secure it using standard equipment rack screws (not provided). Refer to Figure 69.

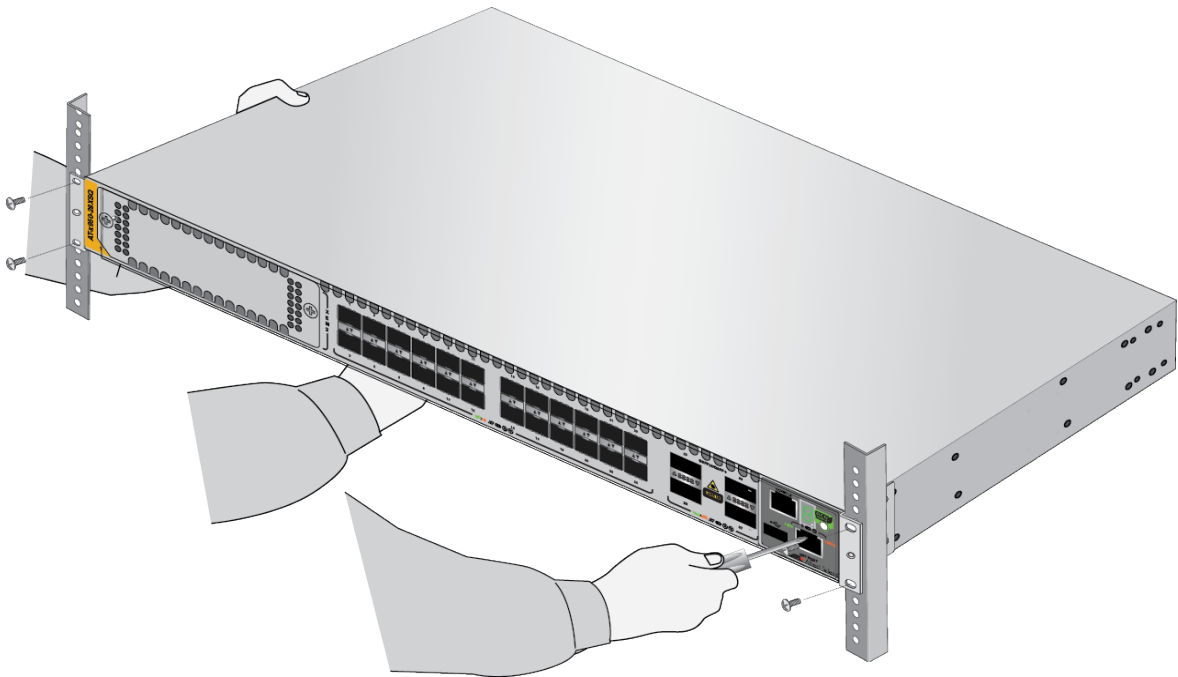

Figure 69. Installing the Switch in an Equipment Rack

5. Do one of the following:
 - ❑ To install power supplies, go to “Installing PWR600 AC Power Supplies” on page 86.
 - ❑ To install an optional XEM2 Ethernet Line Card, go to “Installing an Optional XEM2 Ethernet Line Card” on page 101.
 - ❑ If all the components are installed, go to Chapter 9, “Verifying and Configuring the Switch” on page 157.

Chapter 7

Installing the Switch on a Wall

The procedures in this chapter are listed here:

- ❑ “Switch Orientations on a Wall” on page 118
- ❑ “Recommended Minimum Wall Area Dimensions” on page 119
- ❑ “Plywood Base for a Wall with Wooden Studs” on page 121
- ❑ “Installation Guidelines” on page 123
- ❑ “Installing the Plywood Base” on page 125
- ❑ “Installing the Switch on the Plywood Base” on page 126
- ❑ “Installing the Switch on a Concrete Wall” on page 129

Switch Orientations on a Wall

You can install the switch on a wall with the front panel on the left or right, as shown in Figure 70. Do not install it with the front panel on the top or bottom.

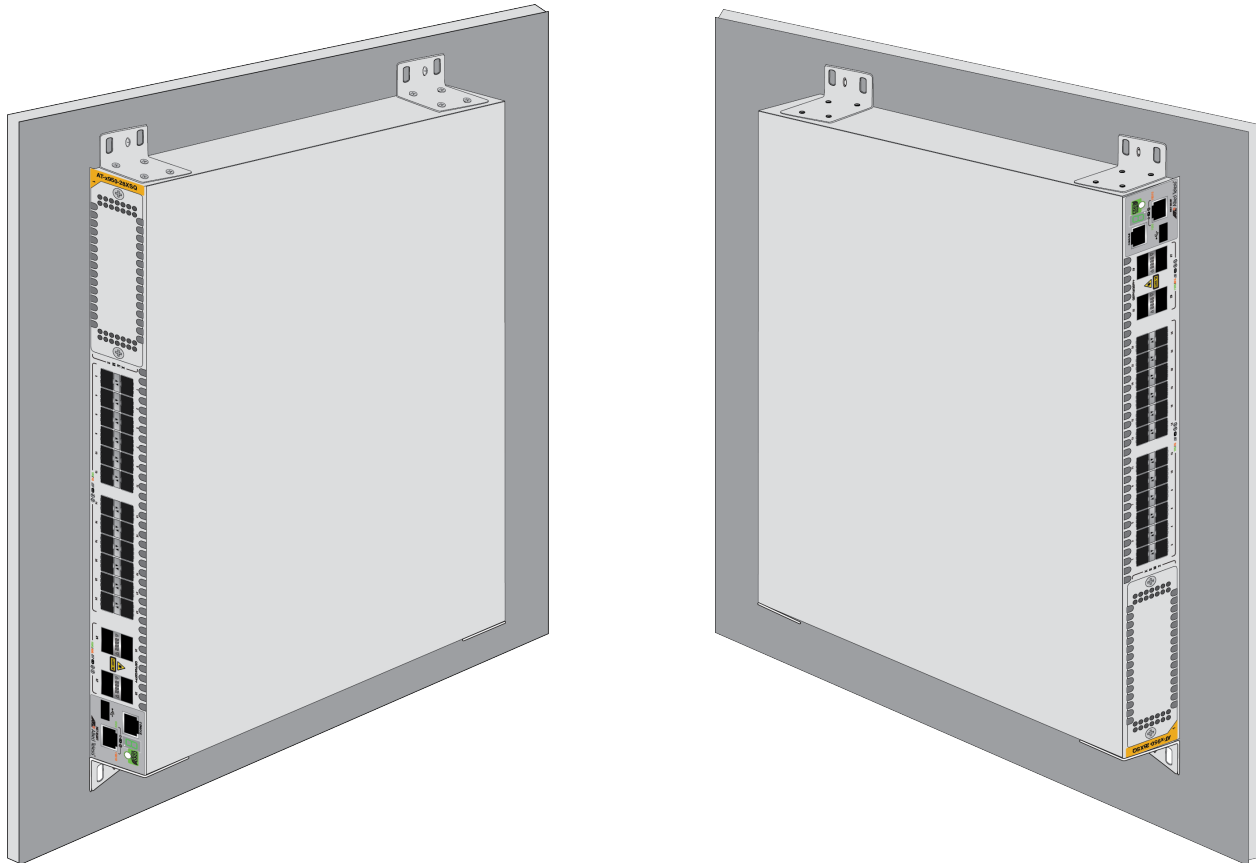

Figure 70. Positions of the Switch on the Wall

Recommended Minimum Wall Area Dimensions

The recommended minimum dimensions for the reserved wall area for the switch are listed here:

- ❑ Width: 96 centimeters (36 inches)
- ❑ Height: 58 centimeters (23 inches)

Figure 71 and Figure 72 on page 120 illustrate the recommended positions of the switch in the reserved area when the front panel is on the left and right, respectively. Be sure to leave sufficient space on the rear panel so that you can replace power supplies or fan modules, if necessary.

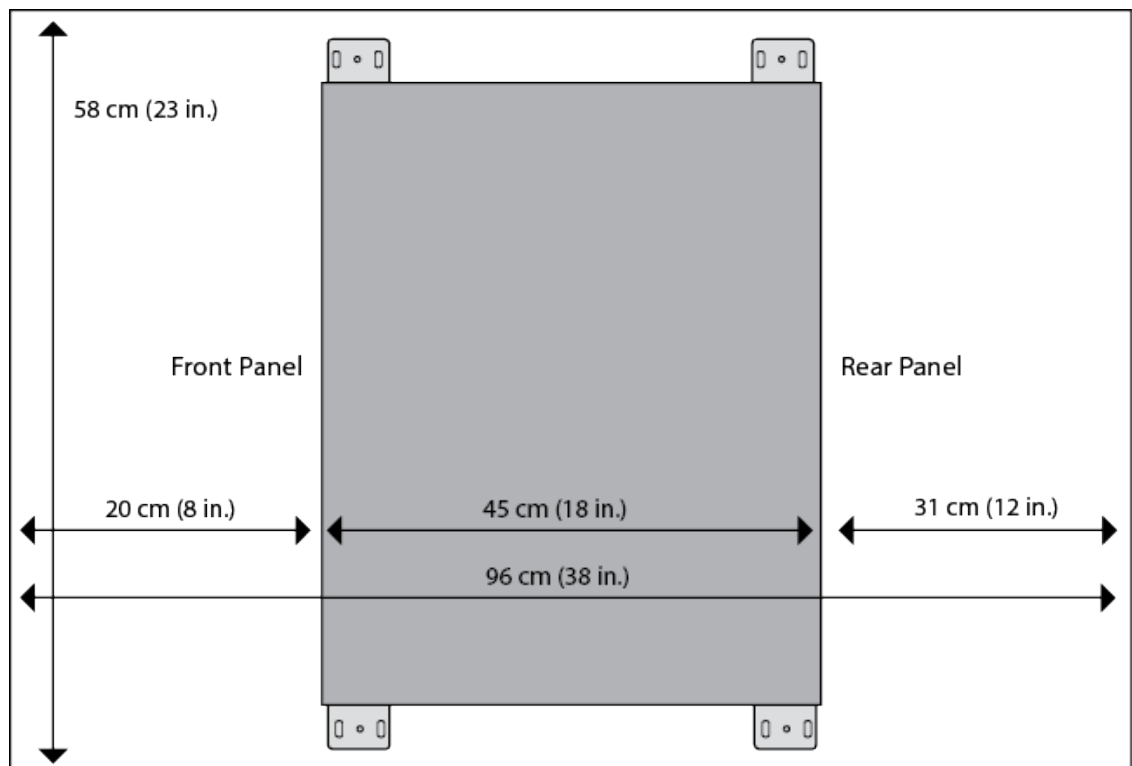

Figure 71. Minimum Wall Area Dimensions with the Front Panel on the Left

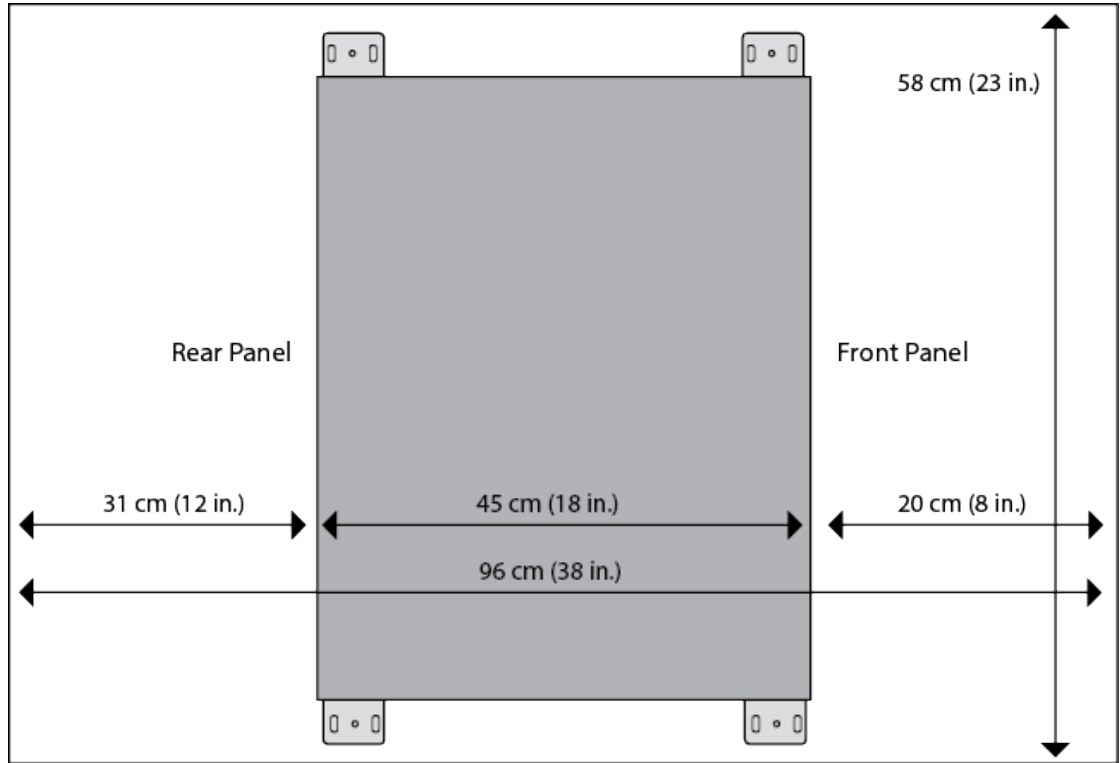

Figure 72. Minimum Wall Area Dimensions with the Front Panel on the Right

Plywood Base for a Wall with Wooden Studs

If you are installing the switch on a wall that has wooden studs, Allied Telesis recommends using a plywood base for the device. (A plywood base is not required for a concrete wall.) Refer to Figure 73.

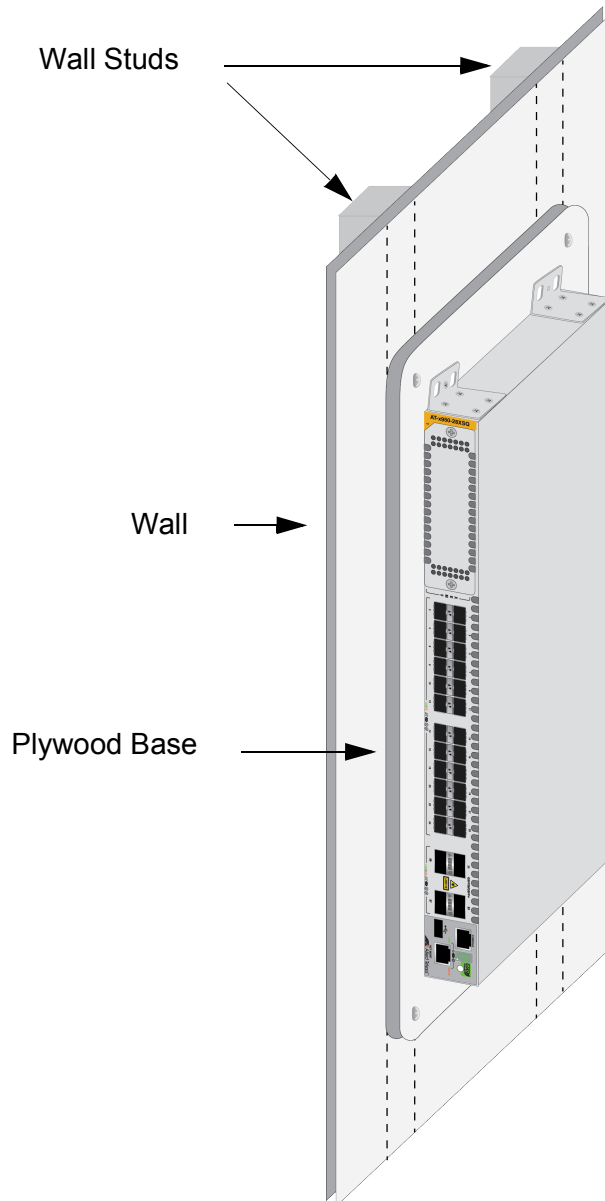

Figure 73. Switch on the Wall with a Plywood Base

The plywood base allows you to mount the switch on two wall studs. Without the base, only one side of the switch would be attached to a stud. This is because the standard distance between two studs in a wall is 41 centimeters (16 inches) while the distance between the left and right brackets on the switch is 37 centimeters (14-1/2 inches).

The recommended minimum dimensions of the plywood base are listed here:

- ❑ Width: 58.4 centimeters (23 inches)
- ❑ Height: 55.9 centimeters (22 inches)
- ❑ Thickness: 5.1 centimeters (2 inches)

The dimensions assume the wall studs are 41 centimeters (16 inches) apart. You may need to adjust the width of the base if the distance between the studs in your wall is different than the industry standard.

You should install the plywood base to the wall and then install the switch on the base. Refer to Figure 74.

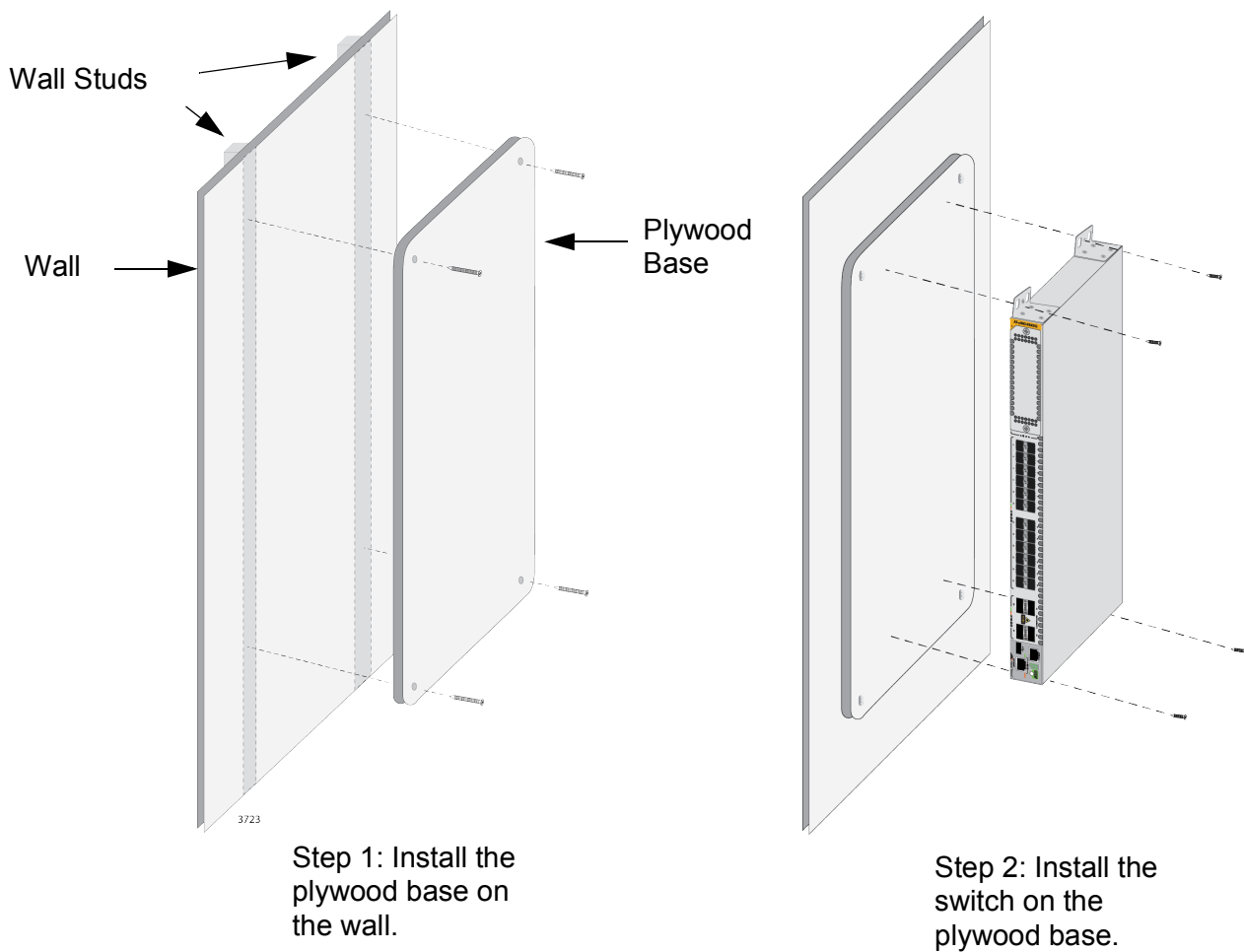

Figure 74. Steps to Installing the Switch with a Plywood Base

Installation Guidelines

Here are the guidelines to installing the switch on a wall:

- ❑ You may install the switch on a wall that has wooden studs.
- ❑ You may install it on a concrete wall.
- ❑ If you are installing the switch on a wall with wooden studs, you should use a plywood base to support the switch. For more information, refer to “Plywood Base for a Wall with Wooden Studs” on page 121. A plywood base is not required for a concrete wall.
- ❑ You should not install the switch on a wall that has metal studs. Metal studs may not be strong enough to safely support the device.
- ❑ You should not install the switch only on sheetrock or similar material. Sheetrock is not strong enough to safely support the device.
- ❑ You should install the power supplies and optional XEM2 Line Card before installing the switch on a wall. For instructions, refer to “Installing PWR600 AC Power Supplies” on page 86 and “Installing an Optional XEM2 Ethernet Line Card” on page 101.



Warning

The device is heavy. Always ask for assistance before moving or lifting it to avoid injuring yourself or damaging the equipment.

 E122



Warning

The device should be installed on a wall by a qualified building contractor. Serious injury to yourself or others or damage to the equipment may result if it is not properly fastened to the wall.

 E105

Note

Depending on your installation, it may be easier to install the power supplies and optional XEM2 Line Card before installing the switch on the wall.

Tools and Material

Here are the required tools and material for installing the switch on a wall:

- Four standard brackets and 16 M3x6mm screws (included with the switch) listed in Table 28 on page 79.
- Four wood or concrete wall screws (included with the switch)
- Four concrete wall anchors (included with the switch)
- Cross-head screwdriver (not provided)
- Stud finder for a wooden wall, capable of identifying the middle of wall studs and hot electrical wiring (not provided)
- Drill and 1/4" carbide drill bit for a concrete wall (not provided)
- Plywood base if you are installing the switch on a wall with wooden studs (not provided.) Refer to "Plywood Base for a Wall with Wooden Studs" on page 121 for illustrations.
- Four screws and anchors for attaching the plywood base to the wall (not provided)



Caution

The supplied screws and anchors may not be appropriate for all walls. A qualified building contractor should determine the hardware requirements for your wall before installing the switch. *ES* E88

Installing the Plywood Base

A plywood base is recommended when installing the switch on a wall that has wooden studs. Refer to “Plywood Base for a Wall with Wooden Studs” on page 121. Consult a qualified building contractor for installation instructions for the plywood base. The installation guidelines are listed here:

- ❑ You should use a stud finder to identify the middle of studs and hot electrical wiring in the wall.
- ❑ You should attach the base to two wall studs with a minimum of four screws.
- ❑ The selected wall location for the base should adhere to the recommendations in “Choosing a Site for the Chassis” on page 74 and “Recommended Minimum Wall Area Dimensions” on page 119.

Installing the Switch on the Plywood Base

This procedure assumes that the plywood base for the switch is already installed on the wall. Please review “Reviewing Safety Precautions” on page 68 and “Choosing a Site for the Chassis” on page 74 before performing this procedure. Allied Telesis recommends a minimum of three people for this procedure.



Warning

The device is heavy. Always ask for assistance before moving or lifting it to avoid injuring yourself or damaging the equipment.

⚡ E122



Warning

The device should be installed on the wall by a qualified building contractor. Serious injury to yourself or others or damage to the equipment may result if it is not properly fastened to the wall.

⚡ E105

Allied Telesis recommends installing the power supplies and optional XEM2 Line Card before installing the switch on a wall. For instructions, refer to “Installing PWR600 AC Power Supplies” on page 86 and “Installing an Optional XEM2 Ethernet Line Card” on page 101.

To install the switch on the plywood base, perform the following procedure:

1. Place the switch in a table.
2. Install the four brackets with the sixteen screws that come with the switch to the sides of the unit, as shown in Figure 75.

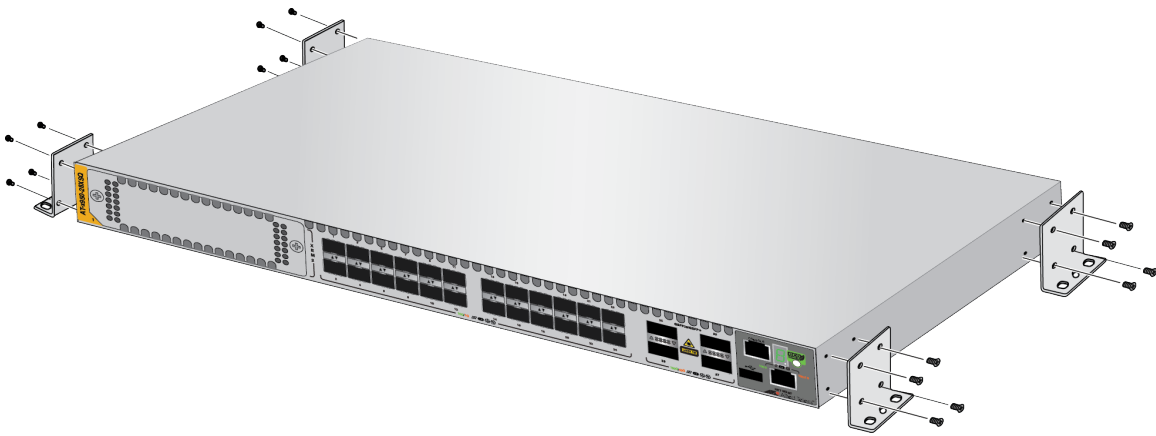

Figure 75. Installing the Brackets to the Switch for Wall Installation

The sides of the switch have two sets of holes. One set is for installing the switch on a wall with the brackets and the other is for the RKMT-SL01 Rack Mounting Kit. For this procedure, you need to use the bracket holes, identified in Figure 64 on page 110.

3. After attaching the brackets to the side of the switch, have two people hold the switch on the plywood base on the wall while you secure it with the four provided screws. Refer to Figure 76 on page 127.

Please follow these guidelines as you position the switch on the wall:

- ❑ Position the switch so that the front panel is either on the left or the right. Refer to Figure 70 on page 118. You may not install the switch with the front panel facing up or down.
- ❑ Leave sufficient space from other devices or walls so that you can access the front and back panels. Refer to “Recommended Minimum Wall Area Dimensions” on page 119.

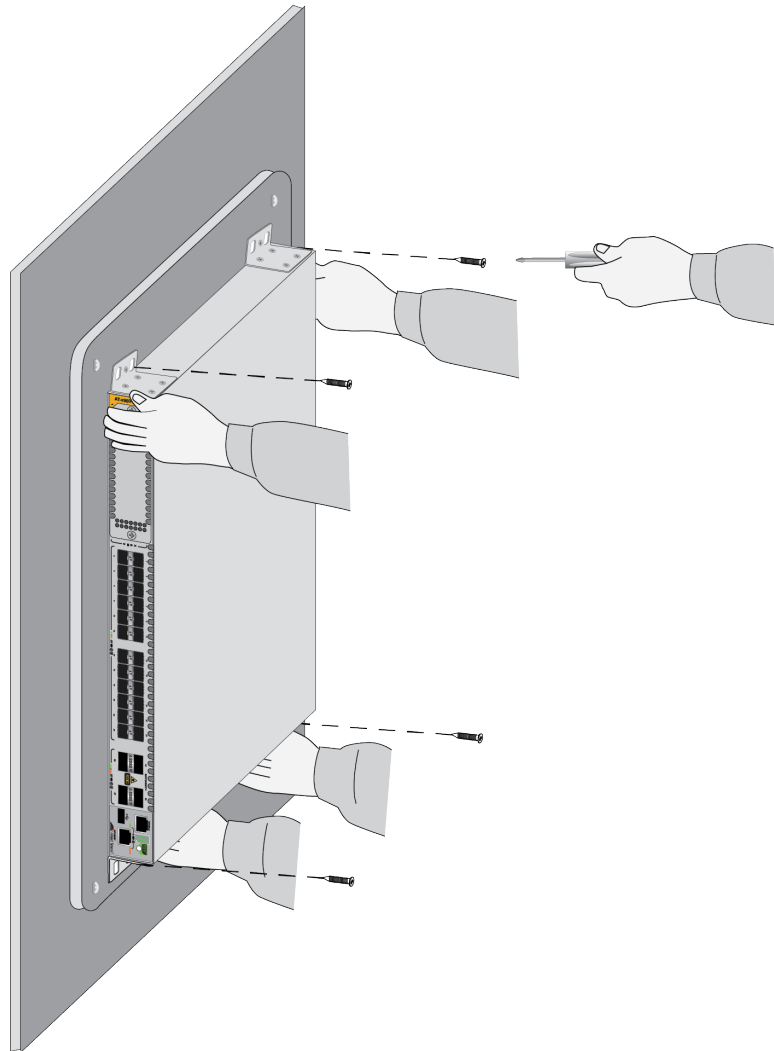

Figure 76. Attaching the Switch to the Plywood Base

4. Do one of the following:
 - ❑ To install the power supplies, go to “Installing PWR600 AC Power Supplies” on page 86.
 - ❑ To install an optional XEM2 Ethernet Line Card, go to “Installing an Optional XEM2 Ethernet Line Card” on page 101.
 - ❑ If all the components are installed, go to Chapter 9, “Verifying and Configuring the Switch” on page 157.

Installing the Switch on a Concrete Wall

Allied Telesis recommends a minimum of three people for this procedure. To install the switch on a concrete wall, perform the following procedure:

**Warning**

The device is heavy. Always ask for assistance before moving or lifting it to avoid injuring yourself or damaging the equipment.

 E122

**Warning**

The device should be installed on a wall by a qualified building contractor. Serious injury to yourself or others or damage to the equipment may result if it is not properly fastened to the wall.

 E105

Allied Telesis recommends installing the power supplies and optional XEM2 Line Card before installing the switch on a wall. For instructions, refer to “Installing PWR600 AC Power Supplies” on page 86 and “Installing an Optional XEM2 Ethernet Line Card” on page 101.

1. Place the switch in a table.
2. Install the four brackets with sixteen screws that come with the switch to the sides of the unit, as shown in Figure 75 on page 126.
3. Have two people hold the switch on the concrete wall at the selected location for the device while you use a pencil or pen to mark the wall with the locations of the four screw holes in the four brackets. Refer to Figure 77 on page 130.

Please follow these guidelines as you position the switch on the wall:

- Position the switch so that the front panel is either on the left or the right. Refer to Figure 70 on page 118. You may not install the switch with the front panel facing up or down.
- Leave sufficient space from other devices or walls so that you can access the front and back panels. Refer to “Recommended Minimum Wall Area Dimensions” on page 119.

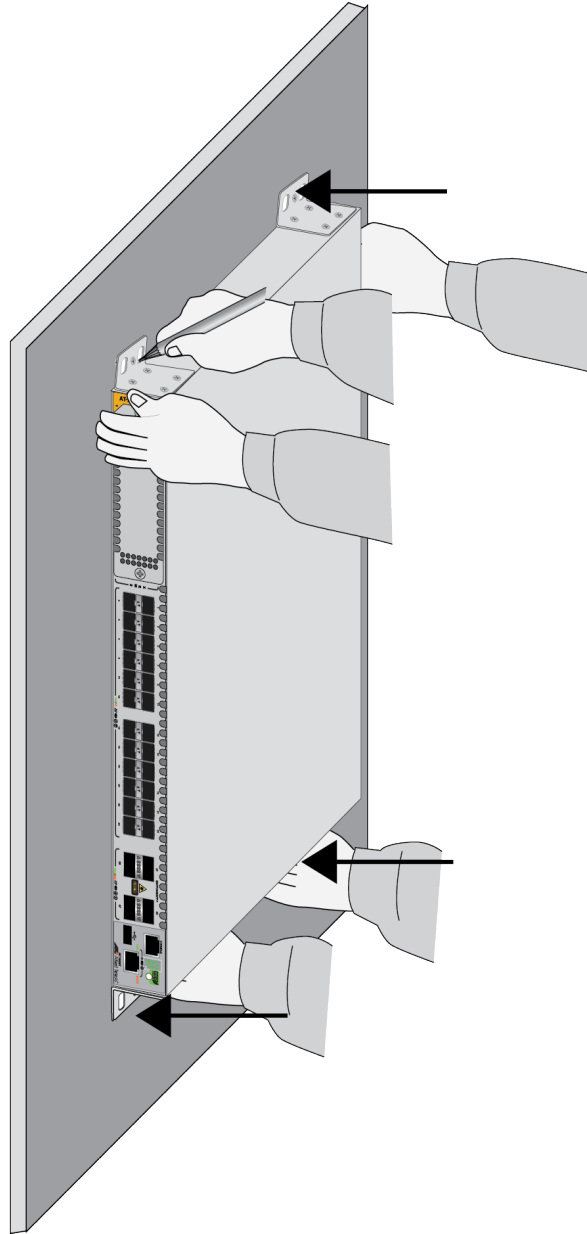

Figure 77. Marking the Locations of the Bracket Holes on a Concrete Wall

4. Place the switch on a table or desk.
5. Use a drill and 1/4" carbide drill bit to pre-drill the four holes you marked in step 3. Please review the following guidelines:
 - ❑ Prior to drilling, set the drill to hammer and rotation mode. The modes break up the concrete and clean out the hole.
 - ❑ Allied Telesis recommends cleaning out the holes with a brush or compressed air.

6. Insert the four anchors into the holes.
7. Have two people hold the switch at the selected wall location while you secure it to the wall with the four provided screws. Refer to Figure 78.

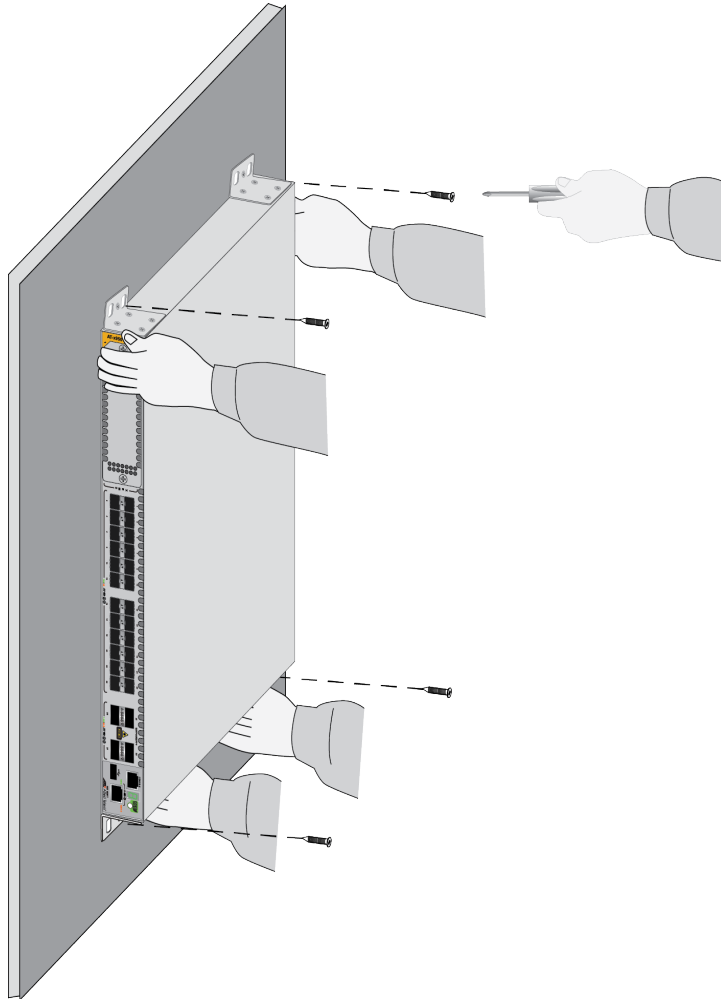

Figure 78. Installing the Switch on a Concrete Wall

8. Do one of the following:
 - To install the power supplies, go to “Installing PWR600 AC Power Supplies” on page 86.
 - To install an optional XEM2 Ethernet Line Card, go to “Installing an Optional XEM2 Ethernet Line Card” on page 101.
 - If all the components are installed, go to Chapter 9, “Verifying and Configuring the Switch” on page 157.

Chapter 8

Installing the Switch in the RKMT-SL01 Sliding Rack

This appendix contains the following sections:

- “Introduction” on page 134
- “Rack Mount Kit Components” on page 135
- “Equipment Rack Requirements” on page 137
- “Reviewing Safety Precautions” on page 138
- “Installation Overview” on page 141
- “Unpacking the Shipping Container” on page 142
- “Installing the Outer Rails on the Equipment Rack” on page 144
- “Installing the Extension Brackets on the Inner Rails” on page 146
- “Installing the Inner Rails on the Switch” on page 152
- “Installing the Switch in the Equipment Rack” on page 154

Introduction

The RKMT-SL01 Rack Mount Kit is a slide-rail type rack-mount kit for Allied Telesis switches in EIA standard 19-inch equipment racks. The kit makes installation and maintenance of network equipment easier by letting you slide switches into or out of equipment racks, including server racks with deep dimensions.

Note

The RKMT-SL01 Kit should only be used with approved Allied Telesis products.

Rack Mount Kit Components

The kit has three main components.

Adjustable Outer Rails

Two adjustable outer rails attach to the equipment rack. They are suitable for racks with depths of 600 mm (23.6 in) to 900 mm (35.4 in). Refer to Figure 79.

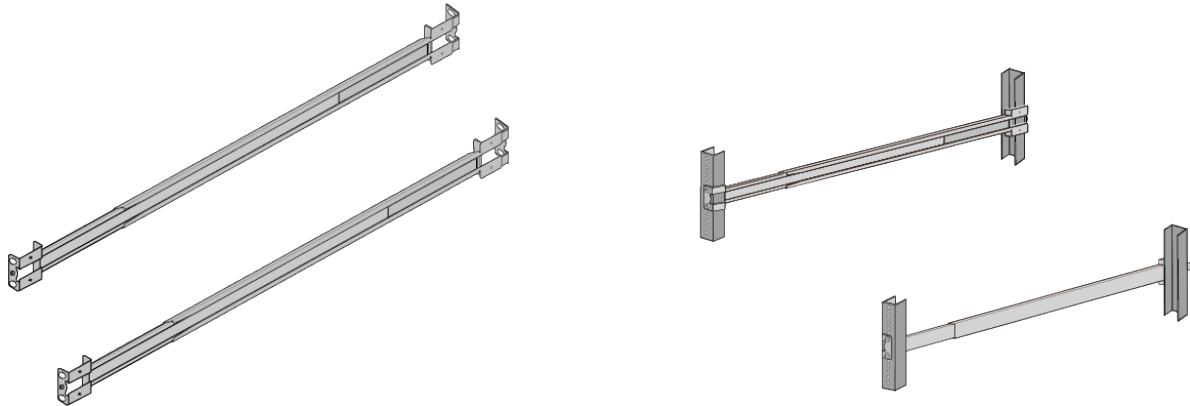

Figure 79. Outer Rails

Inner Rails

Two Inner rails attach to the sides of the switch. Refer to Figure 80.

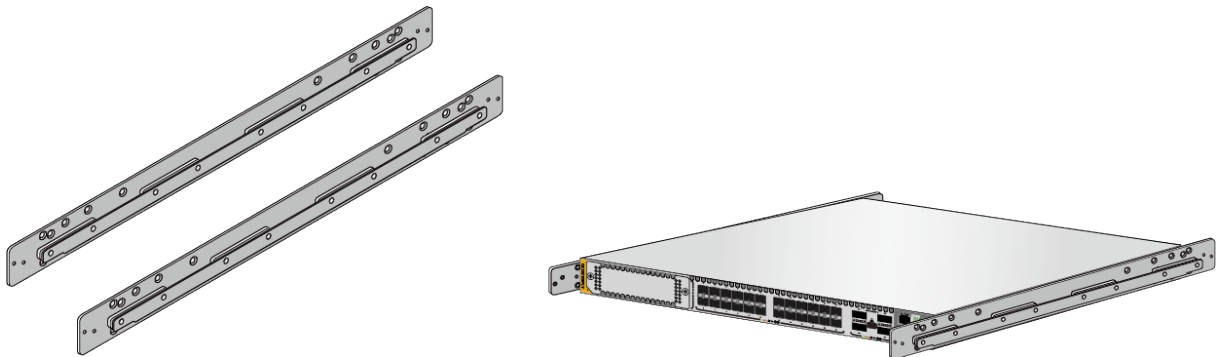

Figure 80. Inner Rails

Extension Brackets

Two extension brackets attach to the front of the inner rails and control the amount the switch is recessed in the equipment rack. The brackets also have a captive screw for securing the switch in the equipment rack. Refer to Figure 81 on page 136.

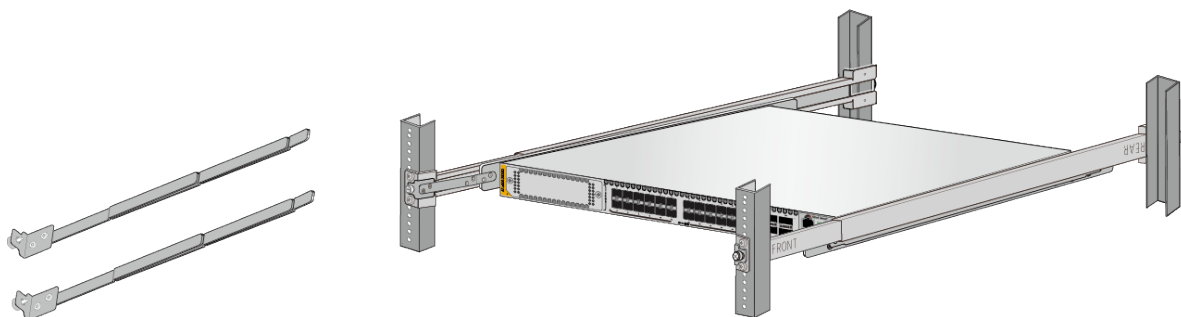

Figure 81. Extension Brackets

Equipment Rack Requirements

The Rack Mount Kit is designed for equipment racks that meet the following requirements:

- ❑ The depth can be from 600 mm (23.6 in) to 900 mm (35.4 in).
- ❑ The width should be a minimum of 452 mm (17.8 in).
- ❑ There should be 35 mm (1.4 in) depth within the rack post for the outer rail mounting.
- ❑ The distance between the left and right wall (for the outer rail mounting) should be a minimum of 10 mm (0.4 in) from the screw hole in the center of the rack posts.

Reviewing Safety Precautions

Review these safety precautions before installing the RKMT-SL01 Kit.

Note

The  indicates that a translation of the safety statement is available in a PDF document titled **Translated Safety Statements** posted on the Allied Telesis website at www.alliedtelesis.com/support.



Warning

Mounting of the equipment in the rack should be such that a hazardous condition is not created due to uneven mechanical loading.  E25



Warning

Do not pull the rear of the switch out past the front rack posts. If you need to position the rear of the switch out past the front of the rack, you should remove it completely from the rack.  E58



Warning

Pull the switch out slowly if you must remove it from the rack for maintenance. If you pull the switch out past the front of the rack posts, or if you pull it out too quickly, there is a risk that the weight of the switch will cause the sliding rail assemblies to fail and cause the switch to fall out.  E59



Caution

Avoid applying excessive force to the cables.  E60



Caution

If using long extension bracket(s), secure between the fixed bracket and short extension bracket - the long extension bracket(s) cannot be attached directly to the inner rail.  E61

**Caution**

Use the adjustment bracket screws supplied with the inner rail. Using screws other than those supplied may result in equipment damage. ⚡ E62

**Warning**

When installing the outer and inner rails, and adjustment bracket, ensure the components are securely attached with the appropriate screws. If not securely attached, a serious accident may occur due to falling equipment. ⚡ E63

**Warning**

When installing and removing the switch from the rack, disconnect the media and power cables. ⚡ E64

**Warning**

A built-in stopper prevents the outer rail from extending beyond its maximum length of 960 mm (37.8 in). Do not extend the rail by force beyond this point, otherwise, the outer bracket will be weakened, and the switch may fall from the rack; equipment could be damaged. ⚡ E65

**Warning**

Ensure the front and rear of both outer rails are attached at the same distance from the floor, otherwise the switch may fall from the rack. ⚡ E66

**Warning**

Be careful to not drop the switch when lifting and not to pinch your fingers when inserting the switch into the rack. ⚡ E67

**Warning**

Other than maintenance work, secure the switch to the outer rail (via the adjustment bracket): If the switch is not secured properly, there is a risk of the switch falling out during movement caused by an earthquake. ⚡ E68



Warning

Do not pull the switch out past the front rack posts. ⚡ E69

Installation Overview

The following steps summarize the installation procedure for the RKMT-SL01 Rack Mount Kit:

1. Verify the contents of the shipping box. Refer to “Unpacking the Shipping Container” on page 142.
2. Attach the outer rails to the equipment rack. Refer to “Installing the Outer Rails on the Equipment Rack” on page 144.
3. Determine the lengths of the extension brackets and install the brackets on the inner rails. Refer to “Installing the Extension Brackets on the Inner Rails” on page 146.
4. Attach the inner rails to the switch. Refer to “Installing the Inner Rails on the Switch” on page 152.
5. Slide the switch into the outer rails. Refer to “Installing the Switch in the Equipment Rack” on page 154.

Unpacking the Shipping Container

The contents of the shipping container are shown in Figure 82.

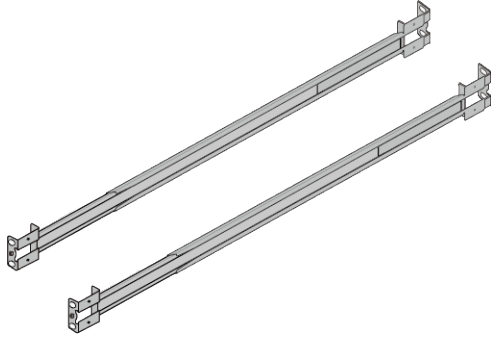

Two outer rails - They attach to the equipment rack. Their lengths are adjustable from 600 to 960 mm (23.6 - 37.8 in).

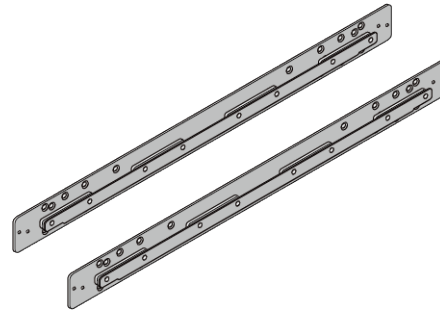

Two inner rails - They attach to the sides of the switch.

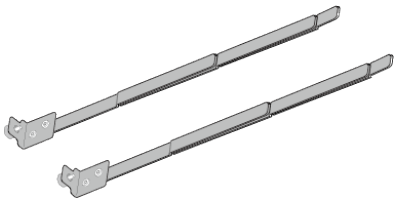

Two extension brackets - They set the distance the switch is recessed in the equipment rack and secure the switch to the rack.



- 16 inner rail screws (M4 x 8 countersunk) - They attach the inner rails to the switch. Screw holes and number of screws vary depending on the switch.
- Four extension bracket screws (M3 x 4 countersunk) - They attach the extension brackets to the inner rails.

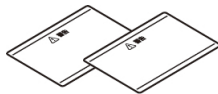

Two warning labels - They are affixed to the top and bottom of the switch and warn against pulling the switch out past the equipment rack posts.

Figure 82. Shipping Container Contents

Note

Store the packaging material in a safe location. You should use the original shipping material if you need to return the kit to Allied Telesis.



Warning

When installing the outer and inner rails, and extension brackets, ensure the components are securely attached with the appropriate screws. If not securely attached, a serious accident may occur due to falling equipment. *⚡* E63

Installing the Outer Rails on the Equipment Rack

To install the outer rails to the equipment rack, perform the following procedure.

1. Locate the FRONT and REAR labels on the sides of the rails. You have to install the rails with the FRONT labels at the front of the equipment rack and the REAR Labels at the back. Refer to Figure 83.



Figure 83. FRONT and REAR Labels on the Outer Rails

2. Attach the outer rails to the equipment rack using the supplied screws. Use four screws per rail. Refer to Figure 84 on page 145. Installing the switch can be easier if you leave the screws slightly loosened now and fully tightened them after the switch is installed.



Warning

Built-in stoppers prevent the outer rails from extending beyond their maximum length of 960 mm (37.8 in). Do not force the rails beyond the maximum length. Otherwise, the brackets will be weakened, and the switch may fall from the rack and be damaged. ⚡ E65



Warning

Verify that the front and rear of both outer rails are attached at the same distance from the floor, otherwise the switch may fall from the rack. ⚡ E66

3. Go to “Installing the Extension Brackets on the Inner Rails” on page 146.

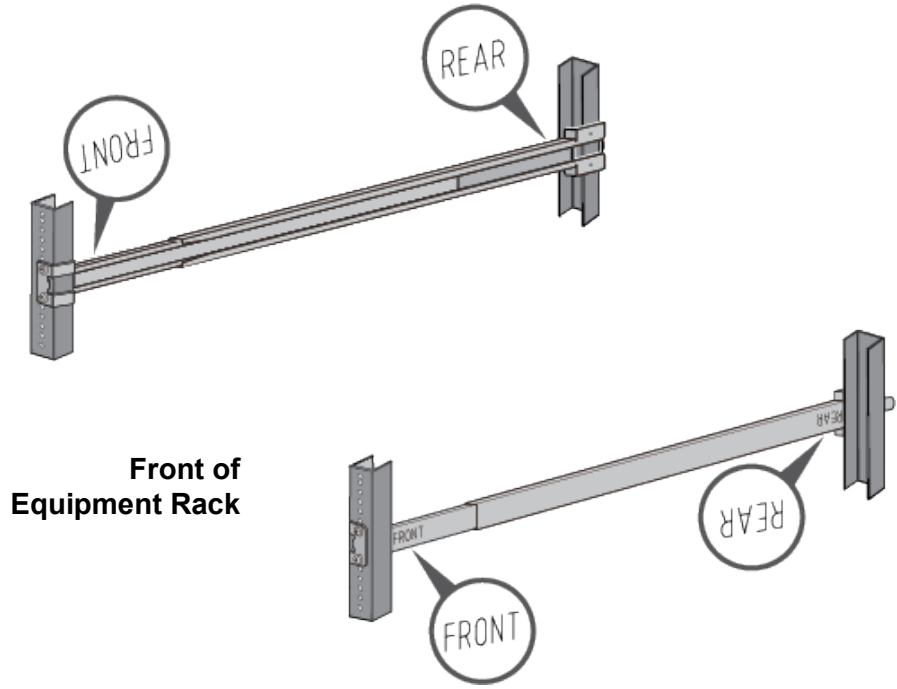

Figure 84. Installing the Outer Rails on the Equipment Rack

Installing the Extension Brackets on the Inner Rails

The kit comes with two extension brackets. Refer to Figure 85.

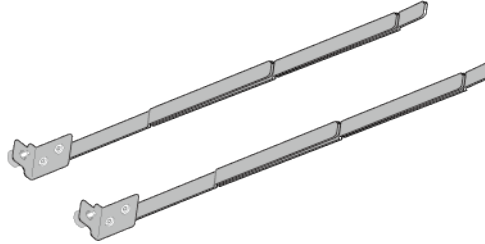

Figure 85. Extension Brackets

You use the brackets to recess the switch in the equipment rack. The maximum distance will depend on the depth of the rack. The deeper the equipment rack, the more the switch can be recessed. The range is approximately 40mm (1.6 in.) to 453mm (17.8 in.). Figure 86 is an example.

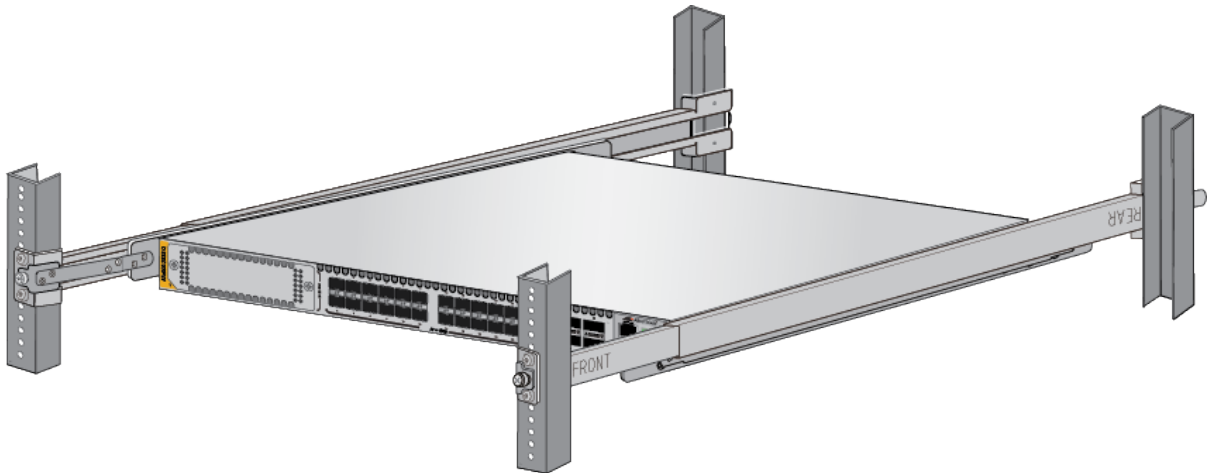

Figure 86. Example of a Switch Recessed in an Equipment Rack

Measuring the Extension Bracket Lengths

The first step is to decide how much you want to recess the front panel of the switch in the rack and then measure the distance. That will tell you the approximate lengths of the extension brackets. Perform the following procedure:

1. Slide one of the inner rails into an outer rail. Be sure that the UP arrow on the inner rail is pointing up. Refer to Figure 87 on page 147.

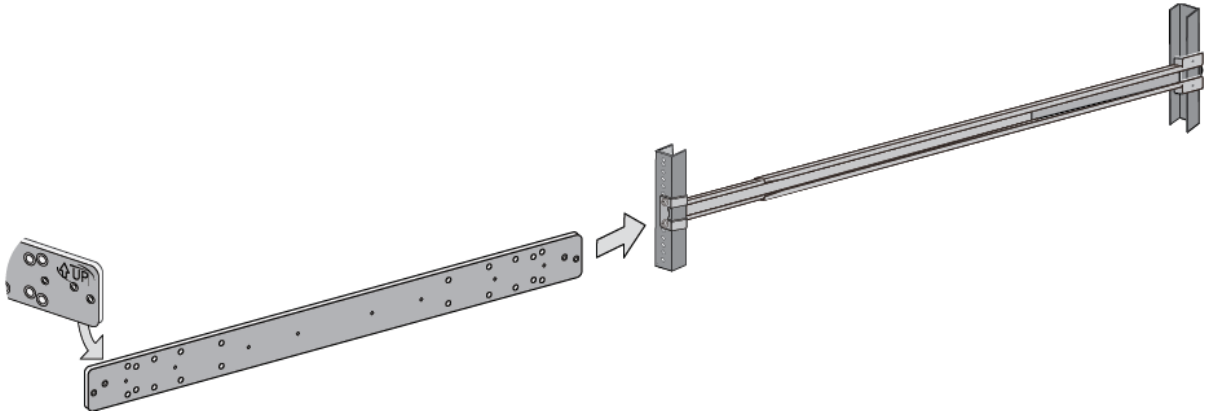

Figure 87. Inserting an Inner Rail into an Outer Rail

2. Position the inner rail at the planned location for the front panel of switch in the sliding rack. Refer to Figure 88.

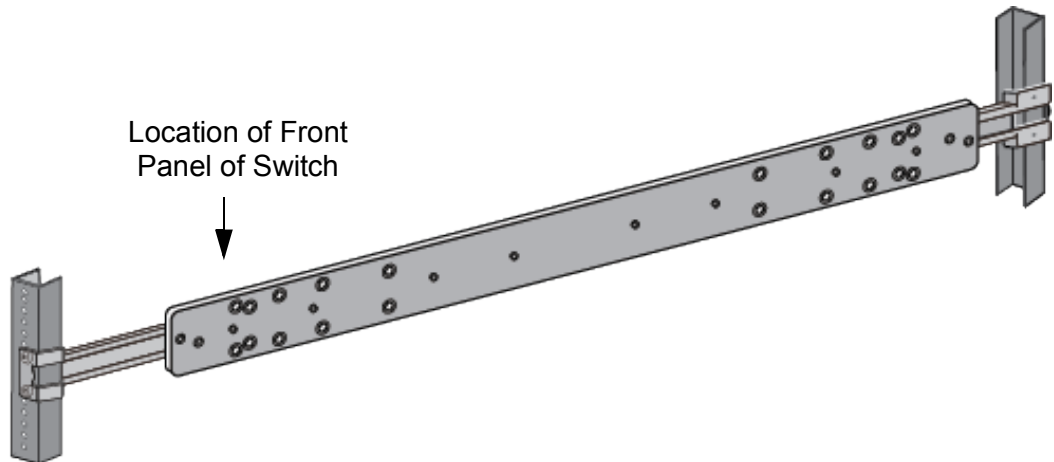

Figure 88. Example of Positioning the Inner Rail

3. Measure the distance from the front of the equipment rack to the front of the inner rail. This will be the approximate length of the extension brackets. Refer to Figure 89.

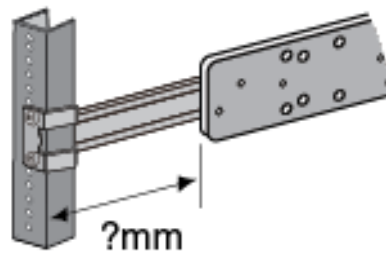

Figure 89. Measuring for the Extension Brackets

- Remove the inner rail from the outer rail. Refer to Figure 90.

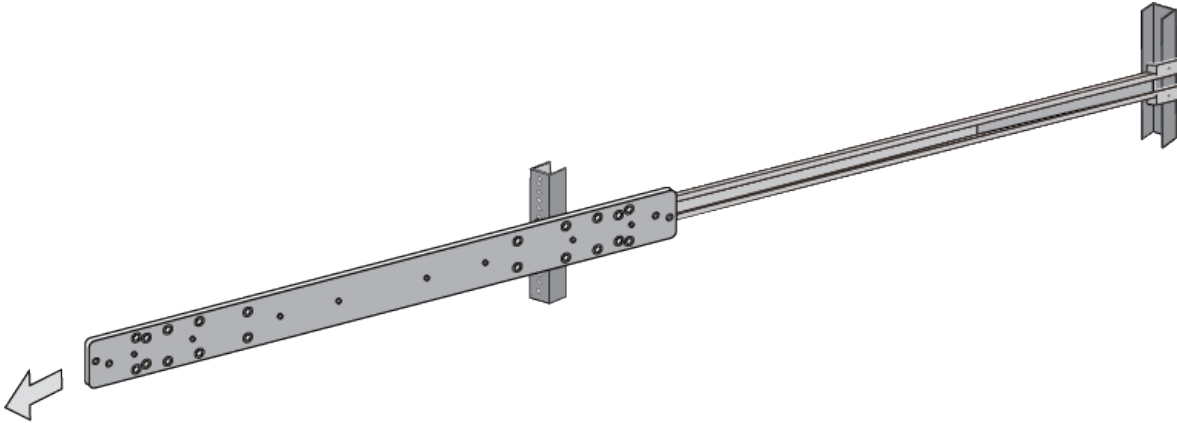

Figure 90. Removing the Inner Rail

- Go to “Assembling the Extension Brackets,” next.

Assembling the Extension Brackets

Now that you know the approximate length for the extension brackets, you are ready to assemble them. The brackets consist of four parts. Refer to Table 30 and Figure 91.

Table 30. Extension Bracket Parts

A	Fixed Bracket	1 ea
B	Long Extension Brackets	2 ea
C	Short Extension Bracket	1 ea

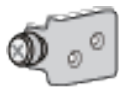

A - Fixed Bracket

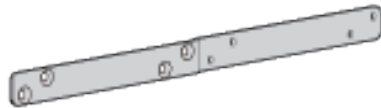

B - Long Extension Bracket

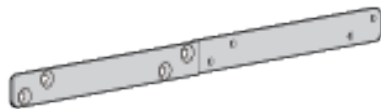

B - Long Extension Bracket



C - Short Extension Bracket

Figure 91. Extension Bracket Parts

You adjust the lengths of the brackets by connecting them in different combinations. There are seven possible configurations. Refer to Figure 92. The default configuration is number 5. To adjust the extension brackets, perform the following procedure:

1. Review Figure 92 to find the bracket length that most closely matches the measurement taken in step 3 in the previous procedure.

#1

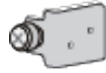

#2

Length:101mm (3.8 in.)

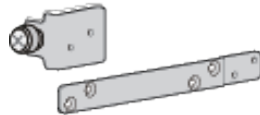

#3

Length:202mm (8.0 in.)

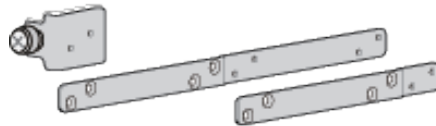

#4

Length:277mm (10.9 in.)

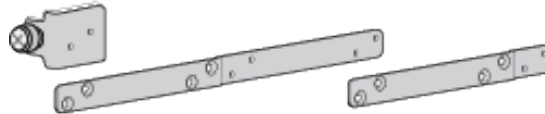

#5

Length:303mm (11.9 in.)
(Factory default)

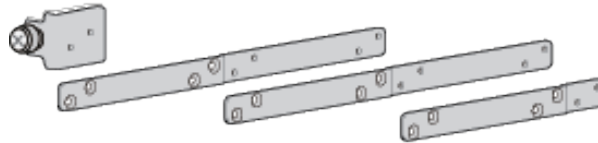

#6

Length:378mm (14.9 in.)

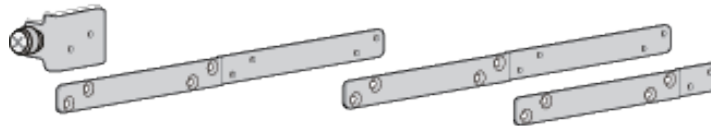

#7

Length:453mm (17.8 in.)

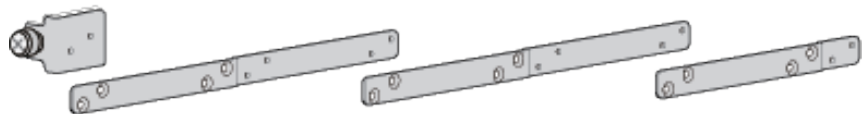

Figure 92. Extension Bracket Configurations

Note

The long brackets have to be used between the fixed and short brackets. You cannot connect them directly to the inner rails.

2. Assemble the extension brackets to match the selected length in the table.
3. Attach the extension brackets to the inner rails. Observe the following:
 - Attach the brackets to the sides of the inner rails with the UP arrows.
 - Attach the screws through the holes on the sides opposite the sides with the UP arrows.



Caution

Use the extension bracket screws supplied with the inner rail. Using screws other than those supplied may result in equipment damage.

⚡ E62

Figure 93 shows an example.

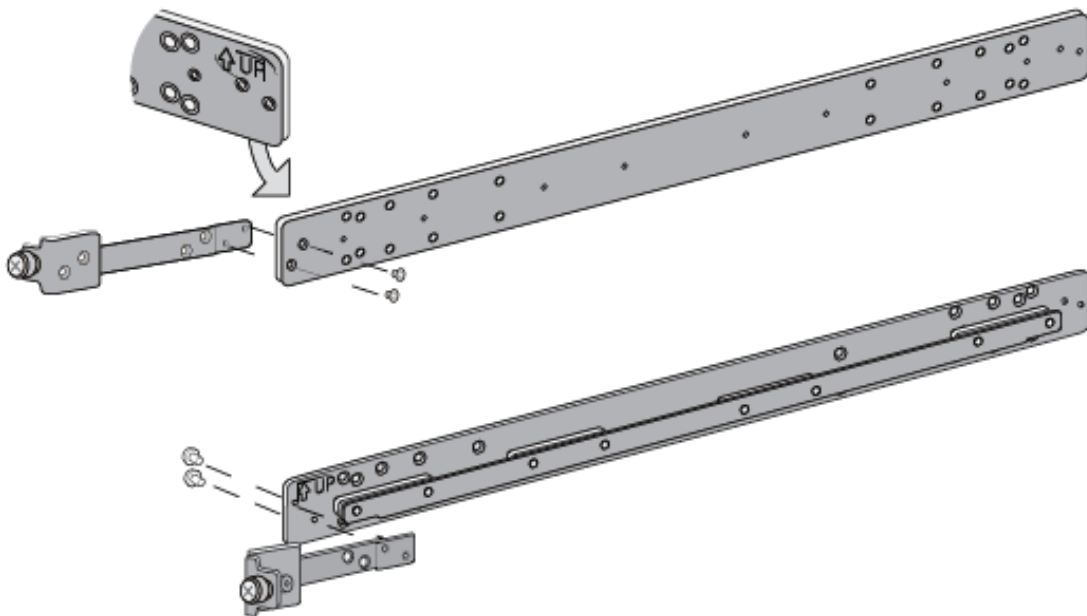

Figure 93. Example of Attaching the Extension Brackets to the Inner Rails

- To test the lengths of the extension brackets, slide the inner rails into the outer rails in the equipment rack. Refer to Figure 94.

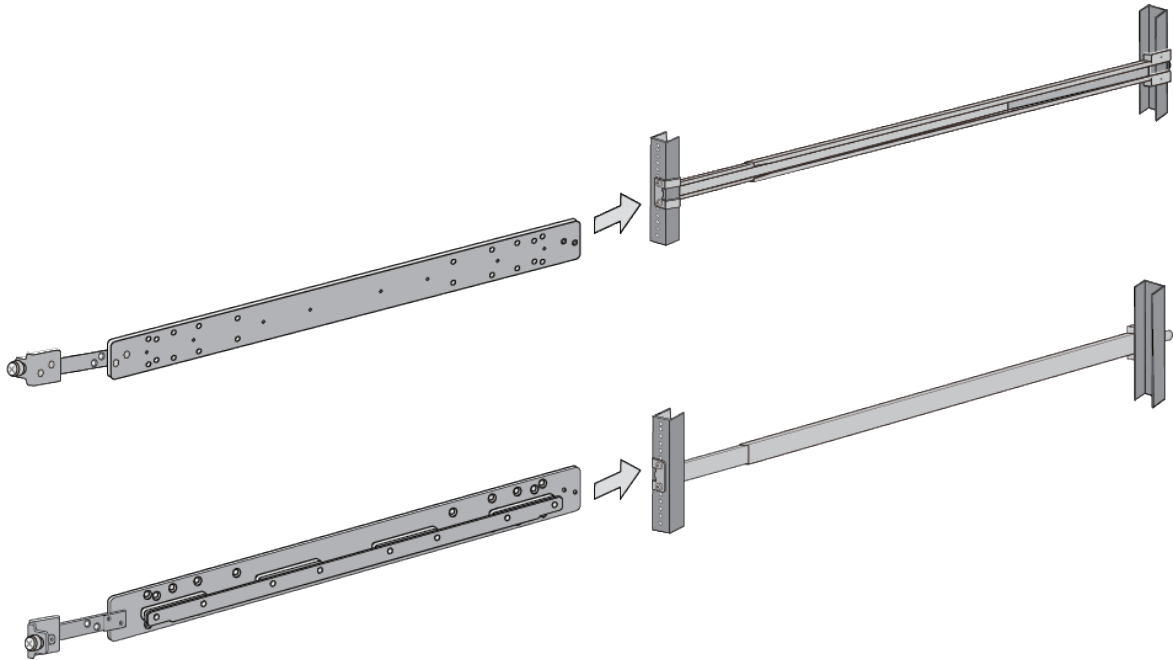

Figure 94. Testing the Inner Rails with the Extension Brackets

- Measure the distance from the front of the equipment rack to the front of the inner rail. Refer to Figure 95. This should approximately match the value you measured in “Measuring the Extension Bracket Lengths” on page 146.

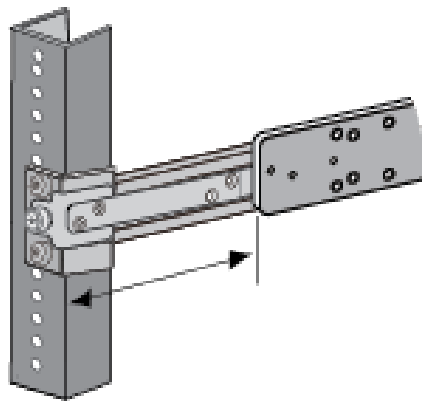

Figure 95. Verifying the Length of the Extension Bracket

- If the extension brackets are the correct length, remove the inner brackets from the outer brackets and go to “Installing the Inner Rails on the Switch” on page 152.
- If the brackets are not the correct length, repeat this procedure.

Installing the Inner Rails on the Switch

The sides of the x950 series switches have two sets of bracket screw holes. The smaller M3 holes are for the standard brackets that come with the switch and the larger M4 screw holes are for the inner rails of the RKMT-SL01 sliding rack. The inner rails are attached to the switch with four M4 screws on each side.

Figure 96 identifies the screw holes on the sides of the x950-28XSQ or x950-28XTQm switch and inner rails.

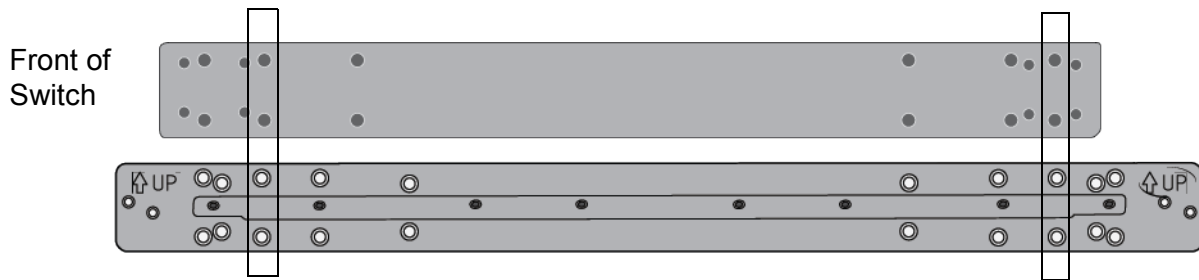

Figure 96. Inner Rail Screw Holes for the x950-28XSQ and x950-28XTQm Switches

Figure 97 identifies the screw holes for the x950-52XSQ or x950-52XTQm switch and inner rails.

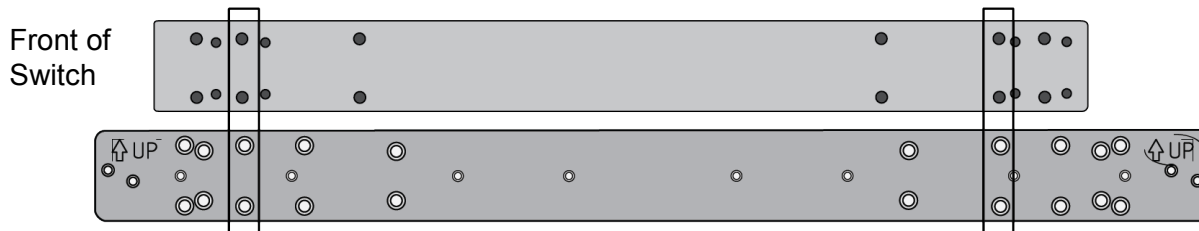

Figure 97. Inner Rail Screw Holes for the x950-52XSQ and x950-52XTQm Switches

Attach the inner rails to the switch using eight M4 screws included with the sliding rack. Be sure that the UP arrows on the rails are pointing up and that the extension brackets extend in front of the switch. Refer to Figure 98 on page 153.

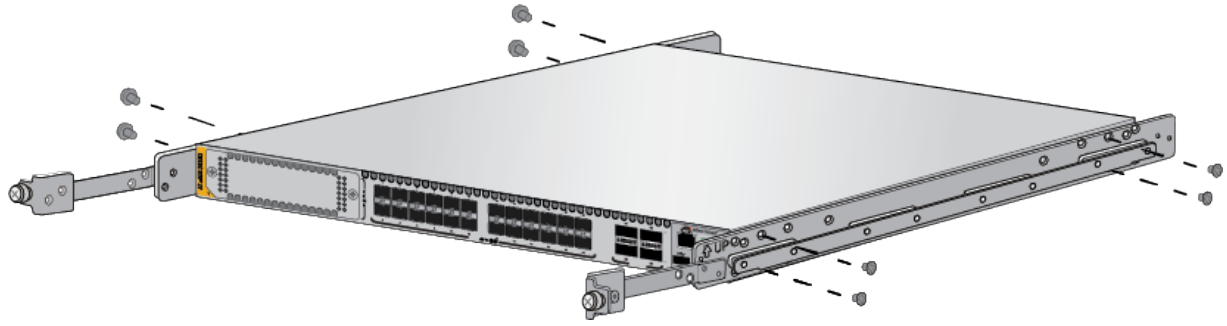

Figure 98. Attaching the Inner Rails to the x950 Switch

Go to “Installing the Switch in the Equipment Rack” on page 154.

Installing the Switch in the Equipment Rack

After attaching the inner rails and extension brackets to the switch, perform the following procedure to install the switch in the sliding rack:



Warning

When installing or removing the switch from the rack, disconnect the media and power cables. ⚡ E64

1. Install the switch in the sliding rack by sliding the inner rails into the outer rail grooves. Refer to Figure 99.

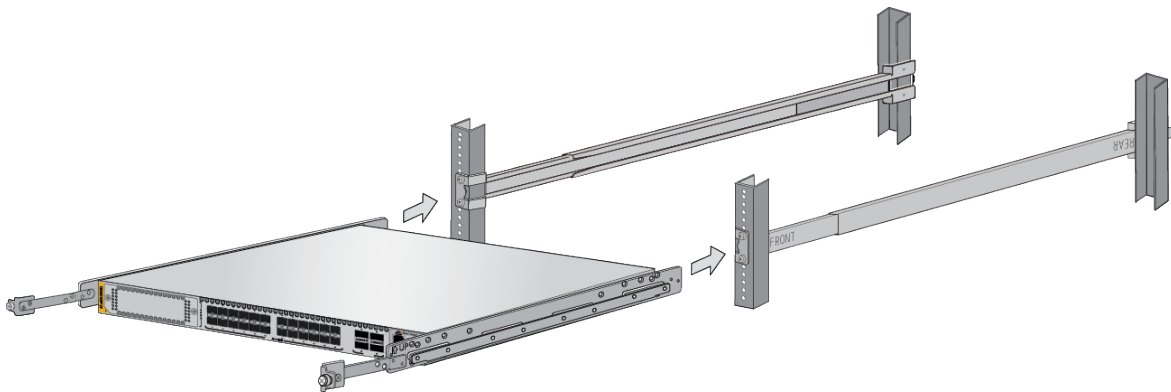

Figure 99. Sliding the Inner Rails on the Switch into the Outer Rails



Warning

Be careful to not drop the switch or pinch your fingers when inserting it into the sliding rack. ⚡ E67

2. Affix the provided warning labels to the top and bottom of the switch, in locations immediately visible when removing the device from the rack. Refer to Figure 100 on page 155.

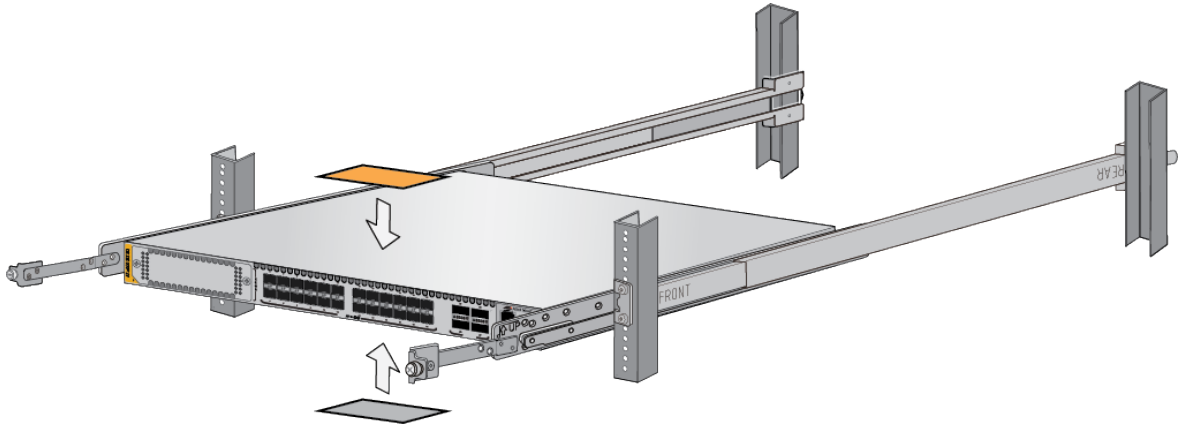

Figure 100. Affixing the Warning Labels

3. Slide the switch fully into the rack.
4. Tighten the two screws on the fixed brackets to secure the switch to the equipment rack. Refer to Figure 101.

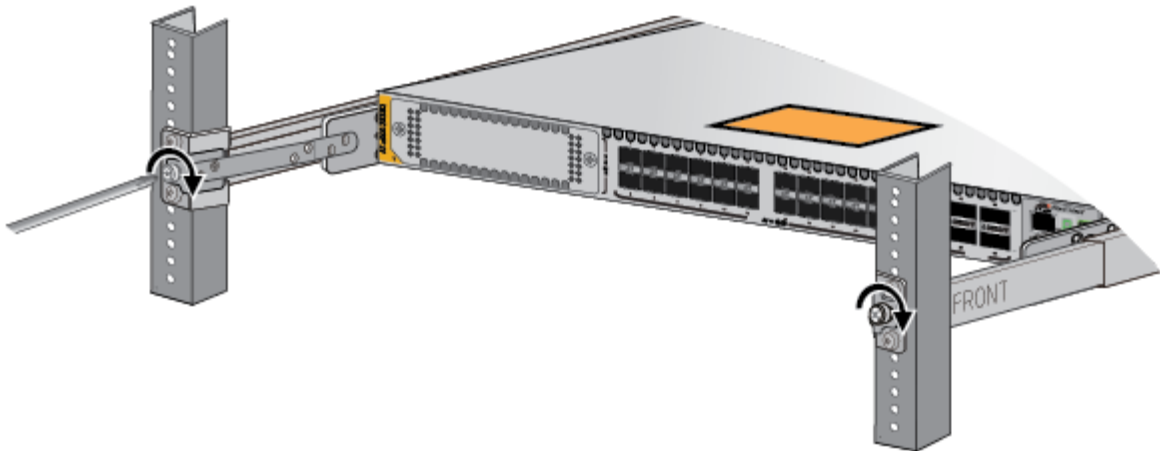

Figure 101. Tightening the Two Screws on the Fixed Brackets



Warning

Always be sure to secure the switch to the outer rail (via the adjustment bracket). If the switch is not secured properly, there is a risk of it falling out during an earthquake. ⚡ E68



Warning

Do not pull the switch out past the front rack posts. ⚡ E69



Warning

Pull the switch out slowly if you must remove it from the rack for maintenance. If you pull the switch out past the front of the rack posts, or if you pull it out too quickly, there is a risk that the weight of the switch will cause the sliding rail assemblies to fail and cause the switch to fall out. ⚠ E59

5. Finish tightening the eight screws on the outer rails to secure the rails to the equipment rack. See Figure 102.

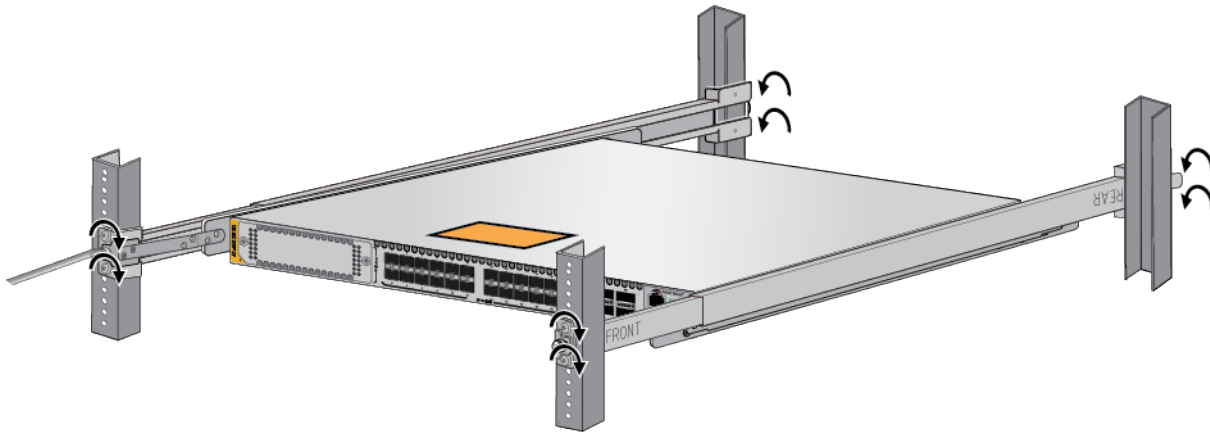

Figure 102. Tightening the Screws on the Outer Rails

This completes the installation procedure.

Chapter 9

Verifying and Configuring the Switch

This chapter contains the following procedures:

- ❑ “Powering On the Switch” on page 158
- ❑ “Starting a Local Management Session” on page 162
- ❑ “Verifying the Switch with AlliedWare Plus Commands” on page 164
- ❑ “Disabling VCStack” on page 165
- ❑ “Configuring Ports for 40Gbps QSFP+ or 100Gbps QSFP28 Transceivers, or Breakout Cables” on page 168
- ❑ “Saving Your Changes and Rebooting the Switch” on page 170

Powering On the Switch

The procedure in this section explains how to power on the switch. If you have not installed the power supplies, refer to “Installing PWR600 AC Power Supplies” on page 86 or/and “Installing PWR600 DC Power Supplies” on page 90 for instructions.

Before powering on the chassis, review the information in “Power Specifications” on page 215.



Warning

Power cord is used as a disconnection device. To de-energize equipment, disconnect the power cord. *ES* E3

Note

Pluggable Equipment. The socket outlet shall be installed near the equipment and shall be easily accessible. *ES* E5

Once powered on, the switch takes approximately two minutes to initialize its operating software. It does not forward network traffic until after it has completed the initialization process. You can monitor the initialization process by connecting a terminal or computer that has a terminal emulator program to the Console port. (The Console port settings are provided in “Starting a Local Management Session” on page 162.)

Powering on the PWR600 AC Power Supply

To power on the switch with the PWR600 AC Power Supply, perform the following procedure:

1. Connect the AC power cord included with the power supply to the AC power connector on the rear panel of the chassis. If the chassis has two power supplies, you may power them on one at a time or simultaneously. Refer to Figure 103 on page 159.

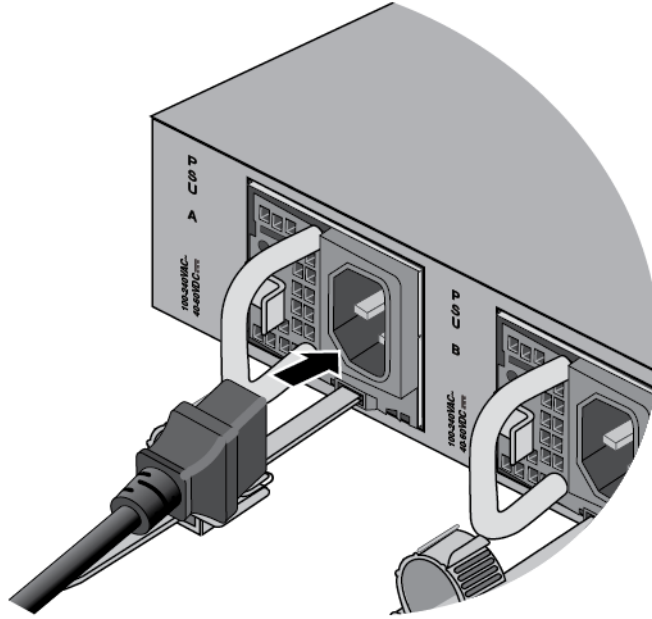
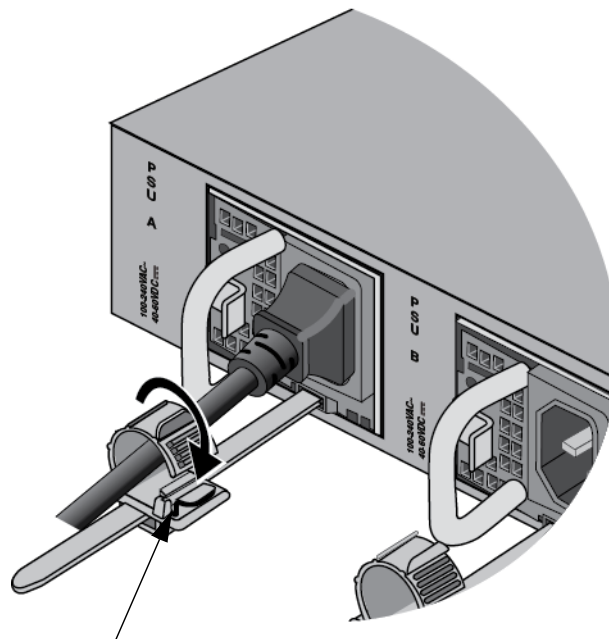

Figure 103. Connecting the AC Power Cord

2. Move the power cord into the restraining strap and secure the strap by feeding it into the tab slot. Refer to Figure 104.



Tab Slot

Figure 104. Securing the Power Cord with the Restraining Strap

3. Connect the power cord to an appropriate AC power source. Refer to Figure 105 on page 160.

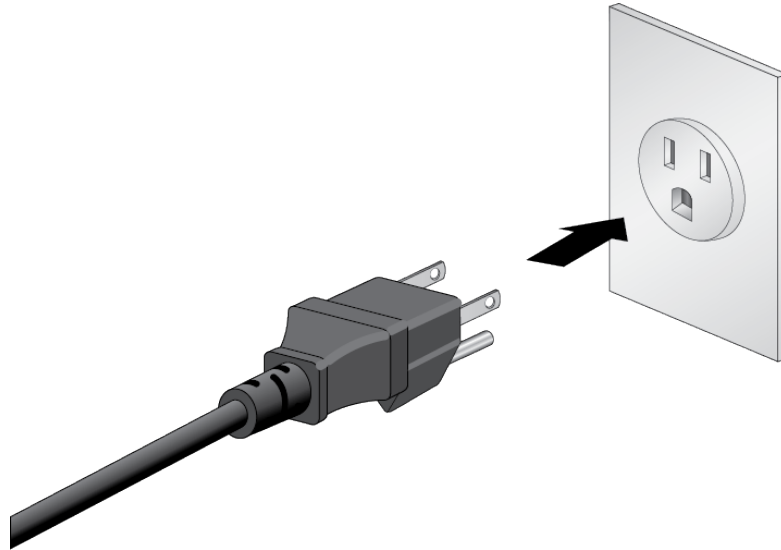

Figure 105. Connecting the Power Cord to an AC Power Source

Note

The illustration shows the North American power cord. Your power cord may be different.

4. If the switch has two AC power supplies, repeat this procedure to connect a power cord to the second power supply.
5. If you have the PWR600 DC power supply installed on the switch, go to “Powering on the PWR600 DC Power Supply” on page 160.
6. Wait two minutes for the switch to initialize its management software.
7. Go to “Starting a Local Management Session” on page 162.

**Powering on the
PWR600 DC
Power Supply**

To power on the switch with the PWR600 DC Power Supply, perform the following procedure:

1. Verify that the DC power source unit that provides power to the switch is powered off. If there are two DC power supplies, verify that both units are powered off.
2. Verify that the DC power wires are connected to the PWR600 DC supply.
3. Connect the other end of the power wire to the DC power source unit. Refer to the documentation included with the unit for instructions.
4. Power on the DC power source unit.

5. If the switch has two DC power supplies installed, repeat this procedure to power on the second DC power supply.
6. If you have the PWR600 AC power supply installed on the switch, go to “Powering on the PWR600 AC Power Supply” on page 158.
7. Wait two minutes for the switch to initialize its management software.
8. Go to “Starting a Local Management Session” on page 162.

Starting a Local Management Session

After powering on the switch and waiting two minutes for it to initialize its management software, start a local management session using the Console port on the management panel, as explained in this section.

Note

The first management session of the switch can be either a local session, as explained in this section, or a remote session over your network through the NET MGMT port. For remote management, the switch uses either its default IP address 192.168.42.42 or an address assigned to it by a DHCP server. For instructions on how to start a remote management session, refer to the *Software Reference for x950 Switches, AlliedWare Plus Operating System*.

To start a local management session, perform the following procedure:

1. Connect the RJ-45 end of the management card included with the switch to the Console RS-232 port on the management panel. Refer to Figure 106.

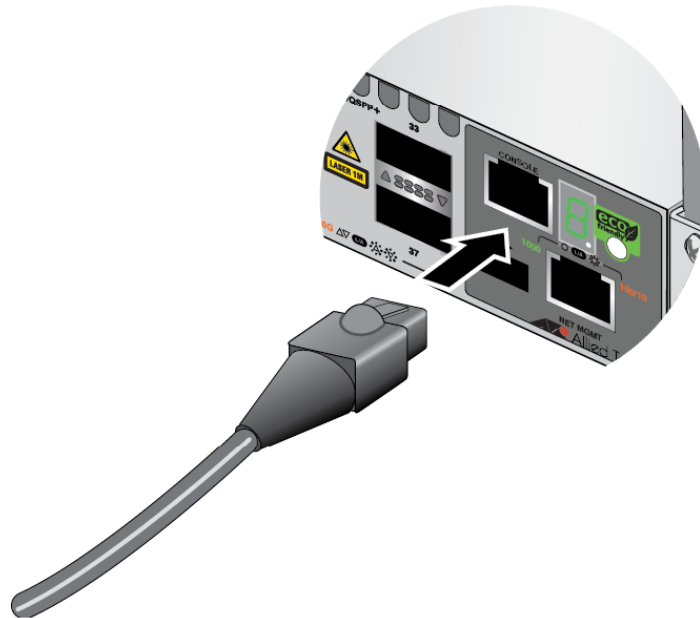

Figure 106. Connecting the Management Cable to the Console RS-232 Port

2. Connect the other end of the cable to an RS-232 port on a terminal or personal computer with a terminal emulation program.

3. Configure the VT-100 terminal or terminal emulation program as follows:
 - Baud rate: 9600 bps
 - Data bits: 8
 - Parity: None
 - Stop bits: 1
 - Flow controller: None

Note

The port settings are for a DEC VT100 or ANSI terminal, or an equivalent terminal emulator program.

4. Press Enter. You are prompted for a user name and password.
5. Enter the default user name and password. They are “manager” and “friend” (without the quotes), respectively

Note

User names and passwords are case sensitive.

The local management session starts when the User Exec mode prompt, shown in Figure 107. is displayed.



```
awplus>
```

Figure 107. User Exec Mode Prompt

Note

The User Exec mode is the first level in the command mode interface. For complete information on the modes and commands, refer to the *Software Reference for x950 Series Switches, AlliedWare Plus Operating System* from www.alliedtelesis.com.

6. Go to “Verifying the Switch with AlliedWare Plus Commands” on page 164.

Verifying the Switch with AlliedWare Plus Commands

Now that the switch is powered on, use the SHOW SYSTEM ENVIRONMENT command in the AlliedWare Plus operating system to verify that the hardware components are operating correctly. To verify the hardware operations, perform the following procedure:

1. Start a local management session on the switch. Refer to “Starting a Local Management Session” on page 162.
2. Enter the SHOW SYSTEM ENVIRONMENT command in the User Exec or Privileged Exec mode.
3. Check the Status column. All components should have the status “OK.”

For information about the command line interface, refer to the *Software Reference for AT-x950 Switches* on the Allied Telesis web site.

4. Go to “Disabling VCStack” on page 165.

Disabling VCStack

The procedure in this section explains how to disable the VCStack feature so that you can use the unit as a stand-alone switch. In all likelihood you will not have to perform this procedure because the default setting for the feature is disabled. A simple way to determine whether the VCStack feature is enabled or disabled is by viewing the Switch ID LED:

- ❑ If the LED is displaying “0”, the VCStack feature is already disabled and the switch is operating as a stand-alone unit. Go to “Configuring Ports for 40Gbps QSFP+ or 100Gbps QSFP28 Transceivers, or Breakout Cables” on page 168.
- ❑ If the LED is displaying the number “1” or higher, the VCStack feature is enabled. You should disable it to use the unit as a stand-alone switch. For instructions, perform the following procedure.



Caution

You have to reset the switch after disabling the VCStack feature. Some network traffic may be lost if the device is connected to a live network. *E89*

If the switch is powered off, start with step 1. If the switch is powered on, start with step 3:

1. Power on the switch by connecting AC power cords to the power supply connectors on the back panel and to AC power sources. Refer to “Powering On the Switch” on page 158.
2. Wait two minutes for the switch to initialize its management software.
3. Start a local management session on the device. Refer to “Starting a Local Management Session” on page 162.
4. Enter the SHOW STACK command in the User Exec mode prompt to display the status of the VCStack feature. An example is shown in Figure 108.

```
awplus> show stack
Virtual Chassis Stacking summary information
ID      Pending ID  MAC address      Priority  Status  Role
1       -           eccd:6dd1:64a2  128     Ready   Active Master
Operational Status           Stacking Hardware Disabled
Stack MAC address           eccd:6dd1:64a2
awplus>
```

Figure 108. SHOW STACK Command

5. Review the following items:
 - ❑ If the Operational Status is “Stacking Hardware Disabled,” the VCStack feature is already disabled on the switch. Go to “Configuring Ports for 40Gbps QSFP+ or 100Gbps QSFP28 Transceivers, or Breakout Cables” on page 168.
 - ❑ If the Operational Status is “Standalone Unit,” the VCStack feature is enabled on the unit. You must disable it by performing the steps in the rest of this procedure, to use the chassis as a stand-alone switch. (The status says “standalone” because the device is functioning as a stack of one switch.)
6. Enter the ENABLE and CONFIGURE TERMINAL commands to move to the Global Configuration mode. Refer to Figure 109.

```
awplus> enable
awplus# configure terminal
Enter configuration commands, one per line. End with CNTL/Z
awplus(config)#
```

Figure 109. Moving to the Global Configuration Mode

7. To disable the VCStack feature, enter the NO STACK ENABLE command in this format:

```
no stack id enable
```

The ID parameter is the ID number of the switch, displayed on the ID LED. Replace the parameter with whatever number is on the ID LED. For example, if the Switch ID LED number is 1, you would enter the command as follows:

```
awplus(config)# no stack 1 enable
```

This confirmation prompt in Figure 110 is displayed.

```
Warning; This will disable the stacking hardware on member-1.
Are you sure you want to continue? (y/n):
```

Figure 110. Confirmation Prompt for the NO STACK ENABLE Command

8. Type Y to disable VCStack on the switch.
9. Enter the EXIT command to return to the Privileged Exec mode. Refer to Figure 111.

```
awplus(config)# exit
awplus#
```

Figure 111. Returning to the Privileged Exec Mode

10. Enter the WRITE command to save your change in the configuration file. The switch displays the confirmation prompt in Figure 112.

```
awplus# write
Building configuration ...
[OK]
awplus#
```

Figure 112. Saving the Changes with the WRITE Command

If this is the first management session, the switch automatically creates the Default.cfg file in flash memory to store your changes.

11. Enter the REBOOT command to reboot the switch.
12. At the confirmation prompt, type “Y” for yes.
13. Wait two minutes for the switch to initialize its management software and then examine the Switch ID LED again. The switch is ready for normal network operations as a stand-alone unit if its ID number is “0.” If the number is “1 or higher,” repeat this procedure, being sure to save the configuration change with the WRITE command in step 11.
14. Go to “Configuring Ports for 40Gbps QSFP+ or 100Gbps QSFP28 Transceivers, or Breakout Cables” on page 168.

Configuring Ports for 40Gbps QSFP+ or 100Gbps QSFP28 Transceivers, or Breakout Cables

Ports 25, 29, 33, and 37 on the x950-28XSQ and x950-28XTQm switches and ports 49, 53, 57, and 61 on the x950-52XSQ and x950-52XTQm switches support the following transceivers and cables:

- ❑ 40Gbps QSFP+ transceivers
- ❑ 100Gbps QSFP28 transceivers
- ❑ 40Gbps to 10Gbps copper and fiber optic breakout cables

You have to configure the ports for the transceivers with the `PLATFORM PORTMODE INTERFACE` command in the Global Configuration mode. The default setting for the ports is 40Gbps QSFP+ transceivers. You can skip this procedure if you will be using only 40Gbps QSFP+ transceivers in the ports.

Note

You have to reset the switch after configuring ports for 100Gbps transceivers or after replacing 100Gbps transceivers with 40Gbps transceivers or breakout cables.

To configure the ports, perform the following procedure:

1. Start a local management session. For instructions, refer to “Starting a Local Management Session” on page 162.
2. Move to the Global Configuration mode by entering the `ENABLE` and `CONFIGURE TERMINAL` commands. Refer to Figure 109 on page 166.
3. Enter the `PLATFORM PORTMODE INTERFACE` command to configure the ports. The format of the command is shown here:

```
platform portmode interface ports 10gx4|40g|100g
```

The variables are defined here:

- ❑ The `PORTS` variable specifies the ports to be configured. The port variables are `PORT1.0.25`, `PORT1.0.29`, `PORT1.0.33`, and `PORT1.0.37`. You can configure more than one port at a time.
- ❑ The `10gx4` parameter configures ports for breakout cables.
- ❑ The `40g` parameter configures ports for 40Gbps QSFP+ transceivers. This is the default setting.
- ❑ The `100g` parameter configures ports for 100Gbps QSFP28 transceivers.

This example configures ports 33 and 37 for 100Gbps QSFP28 transceivers:

```
awplus(config)# platform portmode interface  
port1.0.33, port1.0.37 100g
```

This example configures port 25 for a breakout cable:

```
awplus(config)# platform portmode interface  
port1.0.25 10gx4
```

This example configures ports 25 and 29 for 40Gbps QSFP+ transceivers:

```
awplus(config)# platform portmode interface  
port1.0.25, port1.0.29 40g
```

4. After configuring the ports, go to “Saving Your Changes and Rebooting the Switch” on page 170.

Saving Your Changes and Rebooting the Switch

After disabling the VCStack feature or configuring ports 25, 29, 33, and 37 or ports 49, 53, 57, and 61, you have to save your configuration changes and reboot the switch, as explained in the following procedure:

1. From the Global Configuration mode, enter the EXIT command to return to the Privileged Exec mode, as shown in Figure 111.

```
awplus(config)# exit
awplus#
```

Figure 113. Returning to the Privileged Exec Mode

2. Enter the WRITE command to save your change in the configuration file. The switch displays the confirmation prompt in Figure 112.

```
awplus# write
Building configuration ...
[OK]
awplus#
```

Figure 114. Saving the Changes with the WRITE Command

If this is the first management session, the switch automatically creates a Default.cfg configuration file in flash memory to store your changes.

3. Enter the REBOOT command to reboot the switch.
4. At the confirmation prompt, type “Y” for yes.
5. Wait two minutes for the switch to complete initializing its management software.
6. Examine the Switch ID LED again. The switch is ready for normal network operations as a stand-alone unit if its ID number is “0.” If the number is not “0,” repeat “Disabling VCStack” on page 165. Be sure to save your configuration changes with the WRITE command.
7. Go to Chapter 10, “Cabling the Networking Ports” on page 171.

Chapter 10

Cabling the Networking Ports

This chapter contains the following procedures:

- ❑ “Cabling Twisted Pair Ports” on page 172
- ❑ “Guidelines to Handling Twisted Pair or Fiber Optic Transceivers” on page 173
- ❑ “Installing Transceivers” on page 174
- ❑ “Installing Direct Attach Cables” on page 180

Cabling Twisted Pair Ports

This section applies to the twisted pair ports on the following products:

- ❑ x950-28XTQm Switch
- ❑ x950-52XTQm Switch
- ❑ XEM2-8XSTm Line Card
- ❑ XEM2-12XT Line Card
- ❑ XEM2-12XTm Line Card

Here are the cabling guidelines:

- ❑ Minimum cable requirements are:
 - 100Mbps - Standard TIA/EIA 568-B-compliant Category 3 unshielded cabling.
 - 1/2.5/5Gbps - Standard TIA/EIA 568-A-compliant Category 5 or TIA/EIA 568-B-compliant Enhanced Category 5 (Cat 5e) unshielded cabling.
 - 10Gbps -Standard TIA/EIA 568-C-compliant Category 6a unshielded cabling.
- ❑ The connectors on the cables should fit snugly into the ports, and the tabs should lock the connectors into place.
- ❑ The default speed setting for the ports is Auto-Negotiation. This setting is appropriate for ports connected to network devices that also support Auto-Negotiation.
- ❑ The ports must be set to Auto-Negotiation, the default setting, to operate at 1Gbps, 2.5Gbps, 5Gbps, or 10Gbps.
- ❑ The ports support full-duplex only.
- ❑ Do not attach cables to ports of static or LACP port trunks until you have configure the trunks on the switch. Otherwise, the ports will form network loops that can adversely affect network performance.

Guidelines to Handling Twisted Pair or Fiber Optic Transceivers

Please review the following guidelines before installing twisted pair or fiber optic transceivers:

- ❑ Transceivers are hot-swappable. You can install them while the switch is powered on.
- ❑ For a list of supported transceivers, refer to the product data sheet on the Allied Telesis web site.
- ❑ The operational specifications and fiber optic cable requirements are provided in the documents included with the transceivers.
- ❑ You should install transceivers in XEM2 line cards before connecting their fiber optic cables.
- ❑ Fiber optic transceivers are dust sensitive. Always keep the plug in the optical bores when a fiber optic cable is not installed, or when you store the transceiver. When you do remove the plug, keep it for future use.
- ❑ Repetitive removal or insertion of transceivers can lead to premature failures.
- ❑ 100Gbps transceivers for XEM2-1CQ Line Cards have handles. Use the handles when installing or removing transceivers. An example is shown in Figure 115.

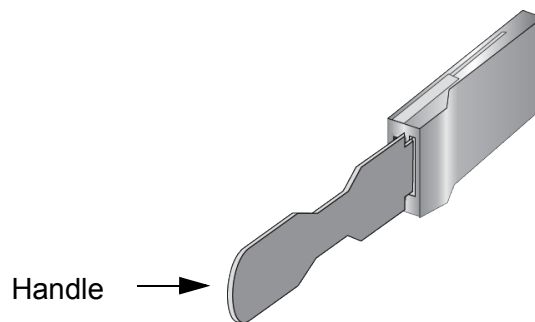

Figure 115. Handle on 100Gbps Transceivers for XEM2-1CQ Line Cards



Caution

Transceivers can be damaged by static electricity. Be sure to observe all standard electrostatic discharge (ESD) precautions, such as wearing an antistatic wrist strap, to avoid damaging the devices. ⚡ E92

Installing Transceivers

Table 31 lists the types of transceivers supported by the base transceiver slots. Refer to the product data sheet for a list of approved transceivers.

Table 31. Transceivers for the Base Transceiver Slots

Base Ports	Fiber Optic Transceiver
Ports 1 to 24 on the x950-28XSQ Switch Ports 1 to 48 on the x950-52XSQ Switch	1Gbps SFP or 10Gbps SFP+ transceivers: <ul style="list-style-type: none"> - 1Gbps SX/LX SFP transceivers - 10Gbps SR/LR SFP+ fiber optic transceivers - 1/10Gbps SP10T transceiver with RJ-45 connector - 10Gbps SP10TW direct attach twinax cables with SFP+ transceiver-style connectors - 1/2.5/5/10Gbps SFP+ transceivers with RJ-45 connectors
Ports 25, 29, 33, and 37 on the x950-28XSQ and x950-28XTQm Switches Ports 49, 53, 57, and 61 on the x950-52XSQ and x950-52XTQm Switches	100Gbps QSFP28 transceivers: <ul style="list-style-type: none"> - QSFP28SR4 transceiver - Maximum operating distance of 70m (230 ft) or 100m (328 ft) with 12-strand OM3 or OM4 fiber optic cable, respectively. Requires a MPO pluggable optical connector. - QSFP28LR4 transceiver - Operating range of 2m (6.6 ft) to 10km (6.2 mi). Requires single-mode fiber optic cable with a duplex LC connector. 40Gbps QSFP+ transceivers, direct attach cables, and breakout cables: <ul style="list-style-type: none"> - QSFPSR4 transceiver - requires 12-strand OM4 fiber optic cable and has a maximum operating distance of 150m (492 ft). - QSFPLR4 transceiver - requires single-mode fiber optic cable and has an operating range of 2 meters (6.6 ft) to 10km (6.2 mi).

Table 31. Transceivers for the Base Transceiver Slots (Continued)

Base Ports	Fiber Optic Transceiver
Ports 25, 29, 33, and 37 on the x950-28XSQ and x950-28XTQm Switches	- QSFP1CU and QSFP3CU direct attach cables in lengths of 1 and 3 meters, respectively.
Ports 49, 53, 57, and 61 on the x950-52XSQ and x950-52XTQm Switches	- QSFP-4SFP10G-3CU and QSFP-4SFP10G-5CU breakout cables in lengths of 3 and 5 meters, respectively.

SP10T and SP10TM transceivers with RJ-45 connections require that adjacent ports be kept empty to prevent overheating. Refer to Figure 116.

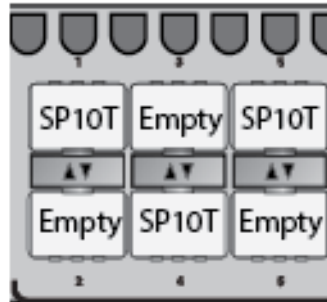

Figure 116. SP10T Transceivers

Table 32 lists the types of transceivers supported by optional XEM2 Line Cards.

Table 32. Transceivers for the Optional XEM2 Ethernet Line Cards

Ethernet Line Card	Transceiver
XEM2-8XSTm	1Gbps SFP or 10Gbps SFP+ transceivers: <ul style="list-style-type: none"> - 1Gbps SX or LX SFP - 10Gbps SR or LR SFP+ - 10Gbps one meter SP10TW1, three meter SP10TW3, and seven meter SP10TW7 direct attach twinax cables, with SFP+ transceiver-style connectors

Table 32. Transceivers for the Optional XEM2 Ethernet Line Cards

Ethernet Line Card	Transceiver
XEM2-12XS	<p>1Gbps SFP or 10Gbps SFP+ transceivers:</p> <ul style="list-style-type: none"> - 1Gbps SX or LX SFP fiber optic transceivers - 10Gbps SR or LR SFP+ fiber optic transceivers - 10Gbps one meter SP10TW1, three meter SP10TW3, and seven meter SP10TW7 direct attach twinax cables with SFP+ transceiver-style connectors (The XEM2-12XS v2 Card does not support the SP10TW7 cable.)
XEM2-4QS	<p>40Gbps QSFP+ transceivers:</p> <ul style="list-style-type: none"> - QSFPSR4 fiber optic transceiver - Maximum operating distance of 150 meters (492 feet) with 12-strand OM4 fiber optic cable. - QSFPLR4 fiber optic transceiver - Operating range of 2 meters (6.6 feet) to 10 kilometers (6.2 miles) with single-mode fiber optic cable. - QSFP1CU and QSFP3CU direct attach cables - Lengths of 1 and 3 meters, respectively.
XEM2-1CQ	<p>100Gbps QSFP28 transceivers:</p> <ul style="list-style-type: none"> - QSFP28SR4 fiber optic transceiver - Maximum operating distance of 70m (230 ft) or 100m (328 ft) with 12-strand OM3 or OM4 fiber optic cable, respectively. Requires a MPO pluggable optical connector. - QSFP28LR4 fiber optic transceiver - Operating range of 2m (6.6 ft) to 10km (6.2 mi). Requires single-mode fiber optic cable with a duplex LC connector. - QSFP28-1CU and QSFP28-3CU direct attach cables in lengths of one and three meters, respectively.

Please review “Guidelines to Handling Twisted Pair or Fiber Optic Transceivers” on page 173 before performing the procedure.

Your transceivers may look different than those shown in the following illustrations.



Warning

The temperature of an operational transceiver can exceed 70° C (158° F). Exercise caution when removing or handling transceivers with unprotected hands. E43

To install a fiber optic transceiver, perform the following procedure:

1. Select a port for the transceiver.
2. If the selected port has a dust cover, remove it.
3. Remove the transceiver from its shipping container and store the packaging material in a safe location.
4. Orient the transceiver and slide it into the port until it clicks into place. The correct orientation depends on the line card and transceiver:
 - ❑ Base ports 1 to 24 and XEM2-8XSTm and XEM2-12XS Line Cards - To install a transceiver in an odd numbered port, position it with its handle on top. To install a transceiver in an even numbered port, position it with its handle on the bottom. Refer to Figure 117 on page 177.

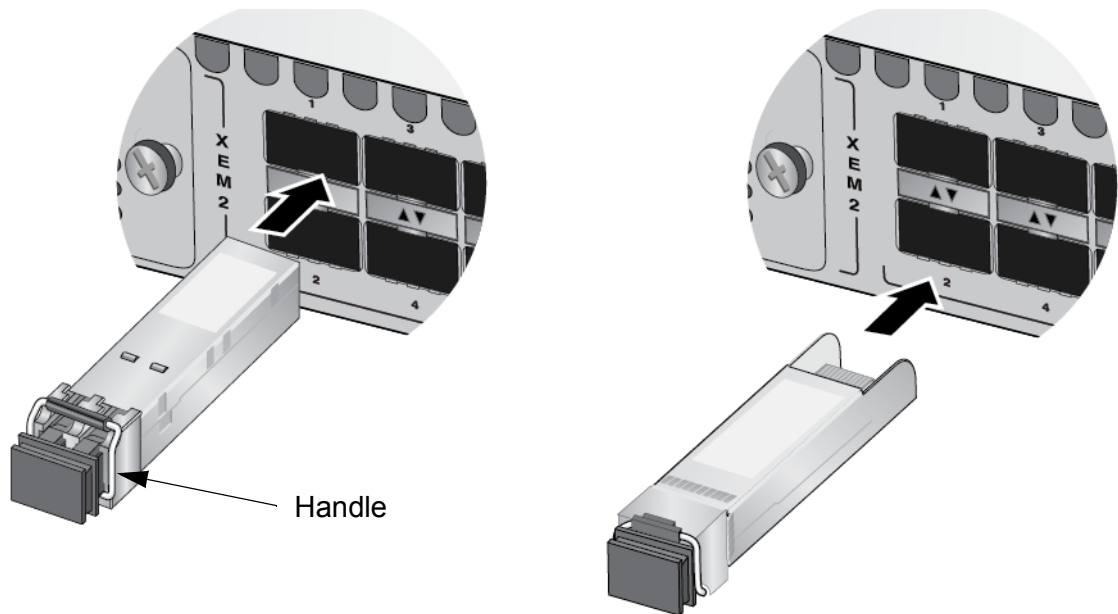

Figure 117. Installing an SFP or SFP+ Transceiver

- ❑ 40Gbps transceivers in XEM2-4QS Line Cards - refer to Figure 118.

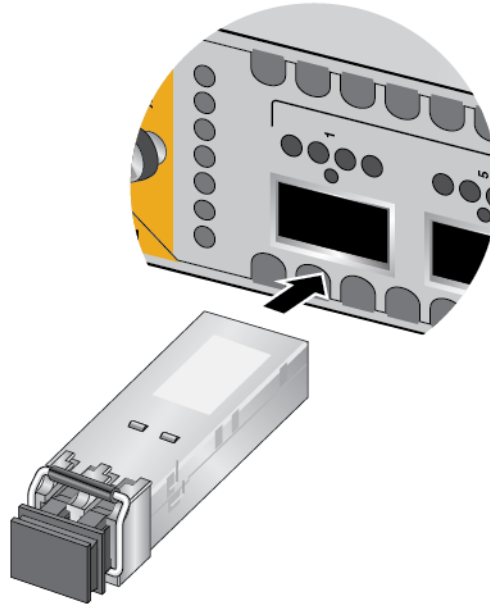

Figure 118. Installing 40Gbps Fiber Optic Transceivers in XEM2-4QS Line Cards

- ❑ 100Gbps QSFP28 transceivers for base ports 25 to 37: refer to Figure 119.

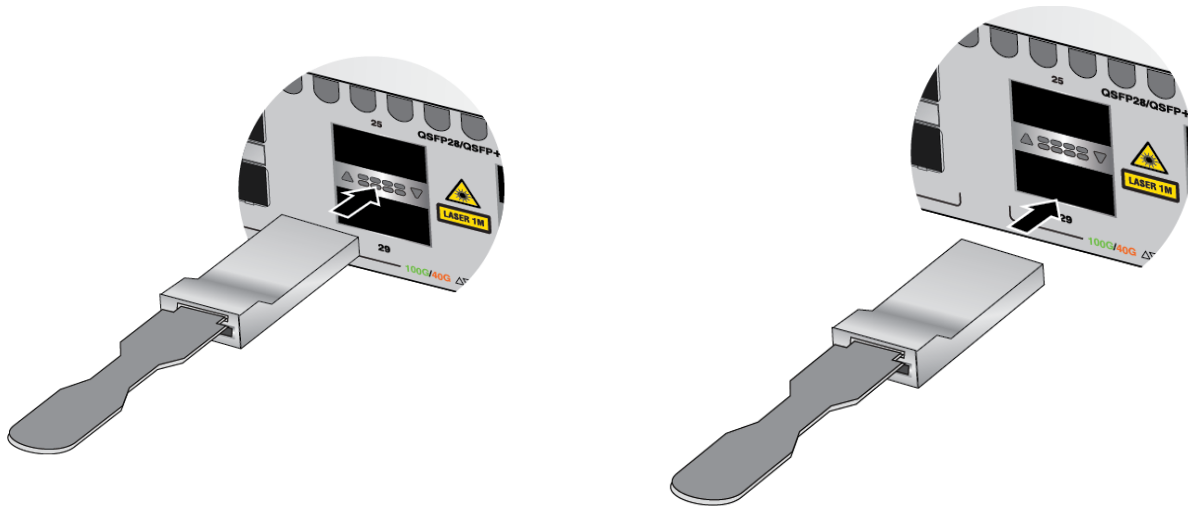

Figure 119. Installing 100Gbps QSFP28 Transceivers in Base Ports 25 to 37

- ❑ 100Gbps QSFP28 transceivers for XEM2-1CQ Line Card: refer to Figure 120.

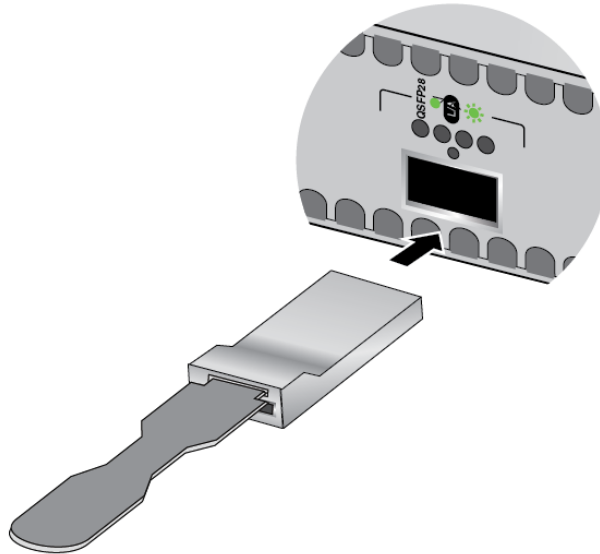

Figure 120. Installing 100Gbps QSFP28 Transceivers in XEM2-1CQ Line Cards

Note

If you are ready to attach the fiber optic cable to the transceiver, continue with the next step. Otherwise, repeat steps 1 to 4 to install additional transceivers.

5. If the fiber optic connector on the transceiver has a dust cover, remove the cover.
6. Connect the fiber optic cable to the connector on the transceiver. The cable is keyed such that it can connect to the transceiver only one way.
7. Repeat this procedure to install additional transceivers.

Installing Direct Attach Cables

Table 11 on page 35 lists the direct attach cables for the base ports and XEM2 Line Cards. They offer an economical way to add 10Gbps, 40Gbps, or 100Gbps connections over short distances. To install direct attach cables, perform the following procedure:

1. Select a port for the direct attach cable.
2. If the selected port has a dust cover, remove the cover.
3. Remove the transceiver from its shipping container and store the packaging material in a safe location.
4. Orient the transceiver and slide it into the port until it clicks into place.
The correct orientation depends on the cable:
 - Figure 121 shows the orientations for SP10TW direct attach cables installed in base ports 1 to 24 and XEM2-8XSTm and XEM2-12XS Cards.

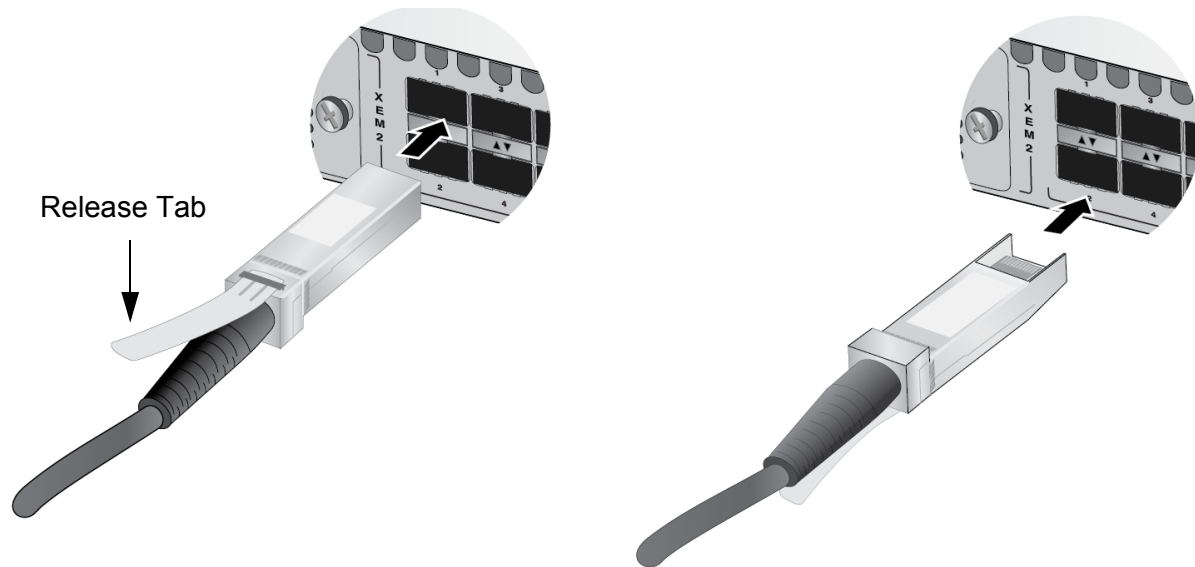

Figure 121. Installing SP10TW Direct Attach Cables

- Figure 122 on page 181 shows the orientations for QSFPcU Cables installed in base ports 25 to 37.

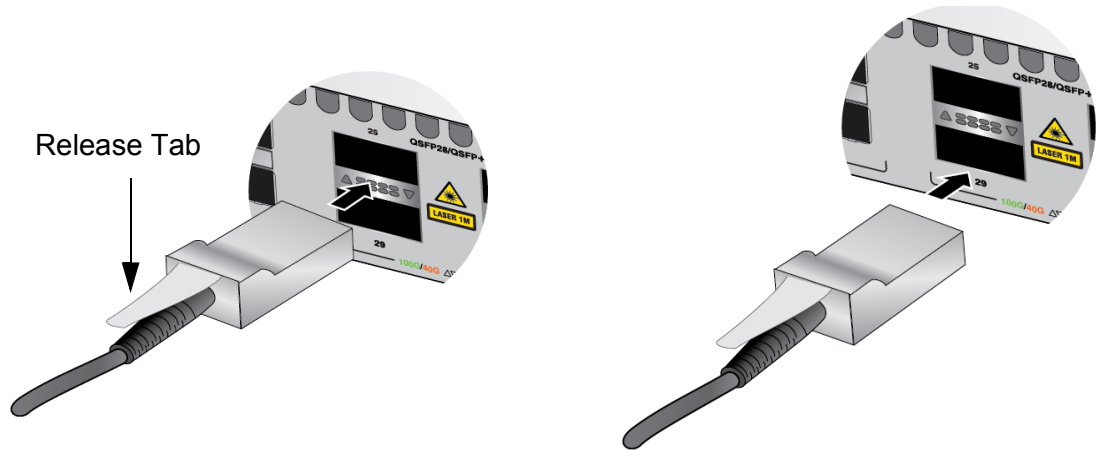

Figure 122. Attaching QSFP+ Cables

5. Connect the other end of the cable into a compatible port on another network device.
6. Repeat this procedure to install additional direct attach cables.

Note

To remove a cable from the port, gently push on the connector, pull on the release tab, and slide the connector from the port.

Chapter 11

Replacing Modules

This chapter contains the following procedures:

- ❑ “Replacing XEM2 Ethernet Line Cards” on page 184
- ❑ “Replacing PWR600 AC Power Supplies” on page 189
- ❑ “Replacing PWR600 DC Power Supplies” on page 194
- ❑ “Replacing FAN05 Modules” on page 197

Replacing XEM2 Ethernet Line Cards

This section contains the procedure for replacing XEM2 Ethernet line cards in x950 Switches. The illustrations in the procedure show the XEM2-12XT line card. The procedure is the same for all cards. Please review the following guidelines before performing the procedure:

- ❑ All XEM2 line cards are hot-swappable. You do not have to power off or reboot the switch when installing or replacing a line card.
- ❑ An XEM2 line card might require up to thirty seconds before becoming fully operational after being powered on.

Note

Allied Telesis recommends saving a backup copy of the configuration file in the switch before removing or replacing line cards. For instructions, refer to the *Software Reference for x950 Switch, AlliedWare Plus Operating System*.

Note

The XEM2 Line Cards are also used in the SBx908 GEN2 Switch. Please note that you have to reboot that switch when hotswapping the XEM2-1CQ Line Card.

This procedure requires the following tool:

- ❑ #2 Phillips-head screwdriver (not provided)

To remove an XEM2 line card from the switch, perform the following procedure:

1. Label and remove all cables from the line card.
2. If the line card has fiber optic transceivers, install dust covers on the ports.
3. If the line card has transceivers or direct attach cables, label and remove the transceivers or cables.



Warning

The temperature of an operational transceiver may exceed 70° C (158° F). Exercise caution when removing or handling transceivers with unprotected hands. *E43*

Note

100Gbps transceivers for the XEM2-1CQ line card have handles. Always use the handles when installing or removing transceivers.

4. Use a #2 Phillips-head screwdriver to loosen the two screws on the faceplate of the card. Refer to Figure 123.

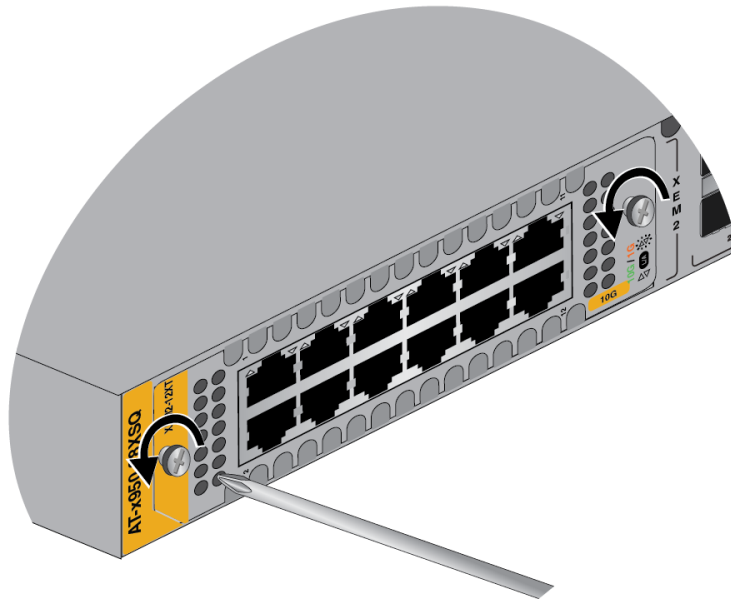

Figure 123. Loosening the Screws on the Ethernet Line Card

5. Carefully pull on the screws on the faceplate to disconnect the line card from the internal connector in the switch. Refer to Figure 124 on page 186.

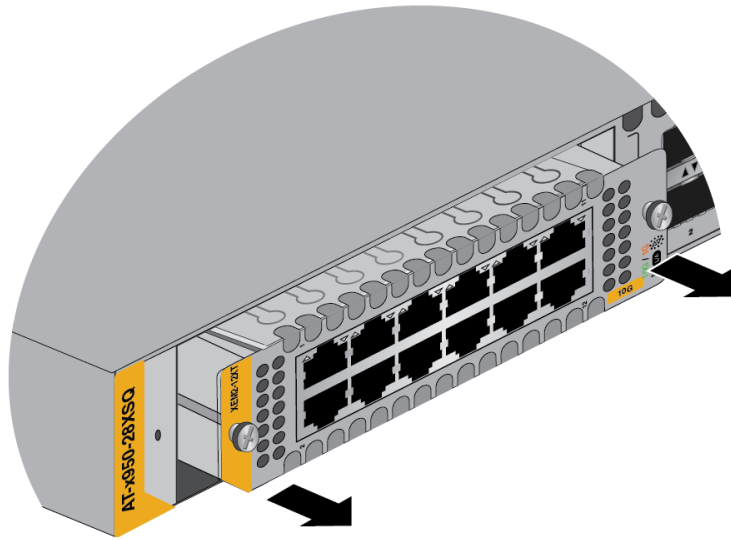

Figure 124. Disconnecting an Ethernet Line Card from the Switch

6. Carefully slide the card from the switch. Refer to Figure 125.

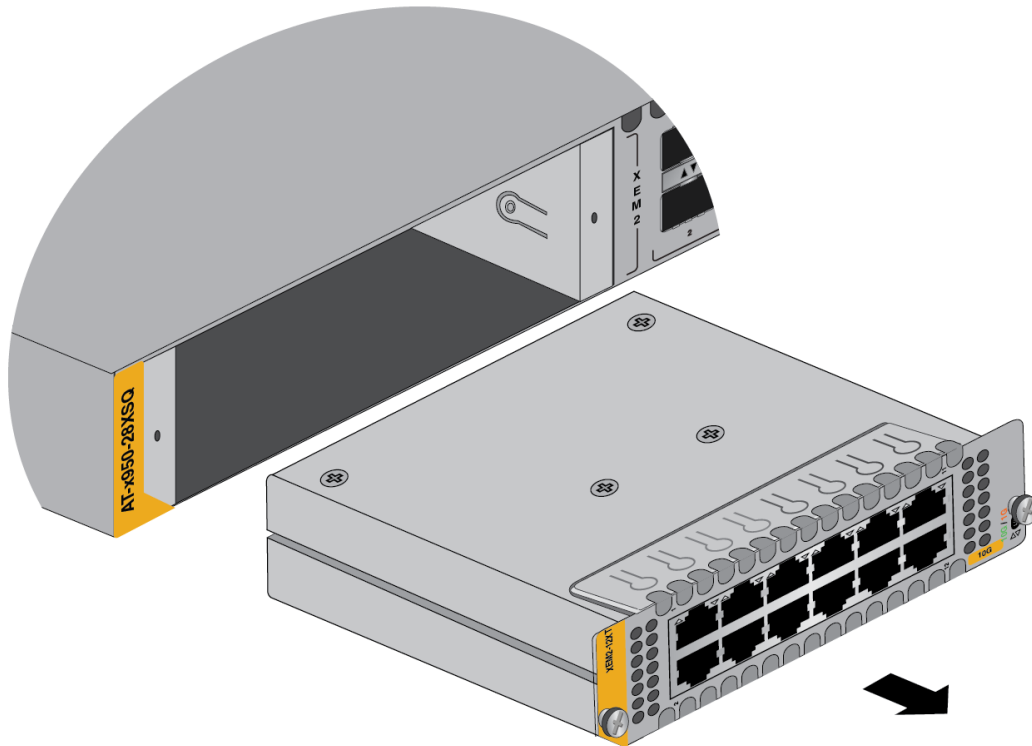

Figure 125. Sliding an Ethernet Line Card from the Switch

7. If you are not installing the line card in another switch, store it in its anti-static bag and shipping container. Refer to Figure 126.



Figure 126. Placing the Ethernet Line Card in its Anti-static Bag

8. Do one of the following:
 - For instructions on how to install another card in the slot, start with step 2 in “Installing an Optional XEM2 Ethernet Line Card” on page 101.
 - If you are not installing another line card in the slot now, continue with the next step to install the blank cover.
9. Orient the blank cover as shown in Figure 127, with the notch on the bottom left, and slid it into the slot.

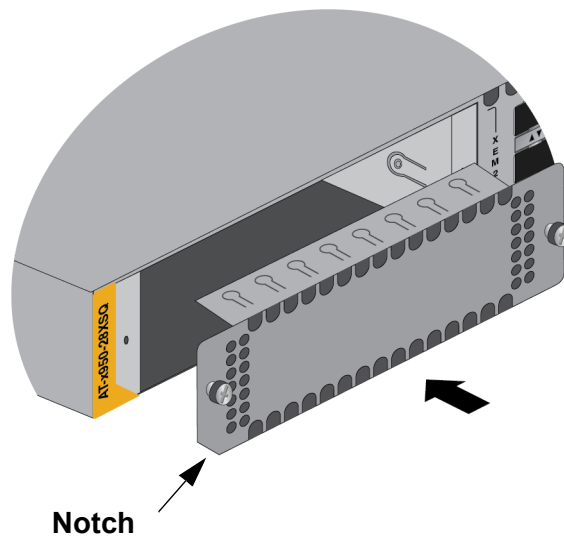

Figure 127. Installing the Line Card Blank Cover

10. Tighten the two screws to secure it to the switch. Refer to Figure 128.

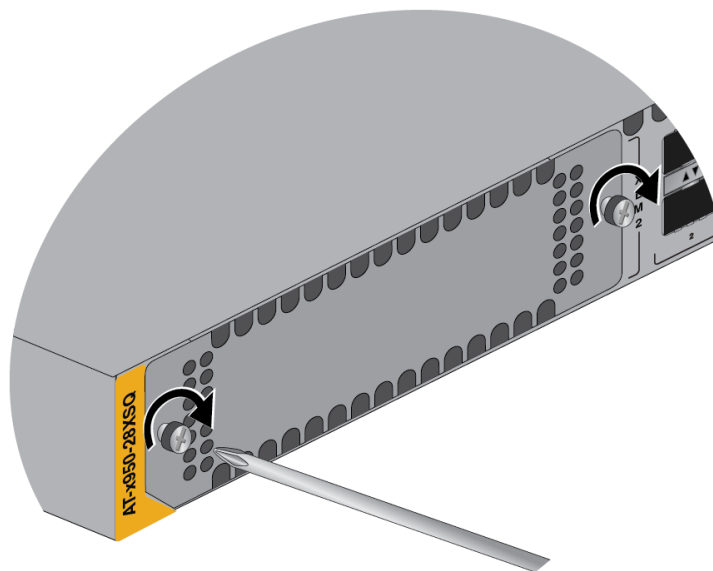

Figure 128. Tightening the Two Screws on the Line Card Blank Panel

Replacing PWR600 AC Power Supplies

This section contains the procedure for removing or replacing PWR600 AC Power Supplies. The following illustrations show the removal of a power supply from slot PSU A. The procedure is the same for replacing a power supply in slot PSU B.

Note

Allied Telesis recommends saving a backup copy of the configuration file in the switch before removing or replacing power supplies. For instructions, refer to the *Software Reference for x950 Switch, AlliedWare Plus Operating System*.

To remove AC power supplies from the switch, perform the following procedure:

1. Disconnect the AC power cord for the power supply from the AC power source. Refer to Figure 129.

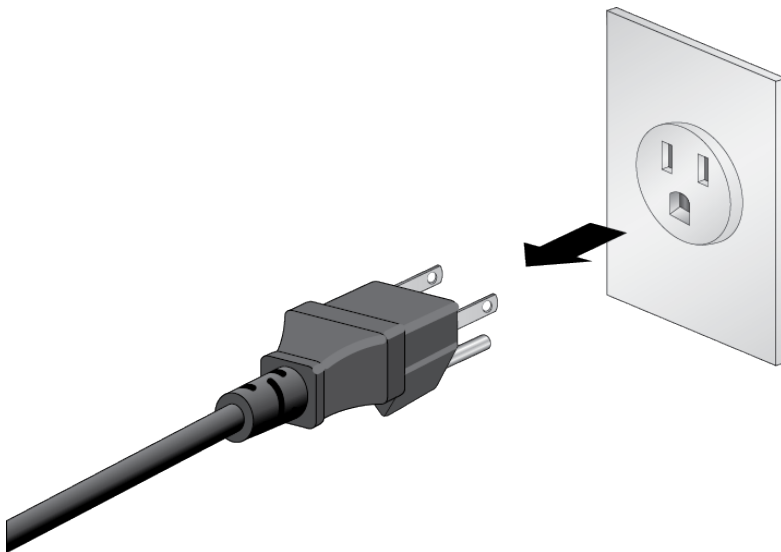

Figure 129. Disconnecting the AC Power Cord from the Power Source

2. Open the restraining strap on the power cord by pressing down on the release tab and pulling out the strap. Refer to Figure 130 on page 190.

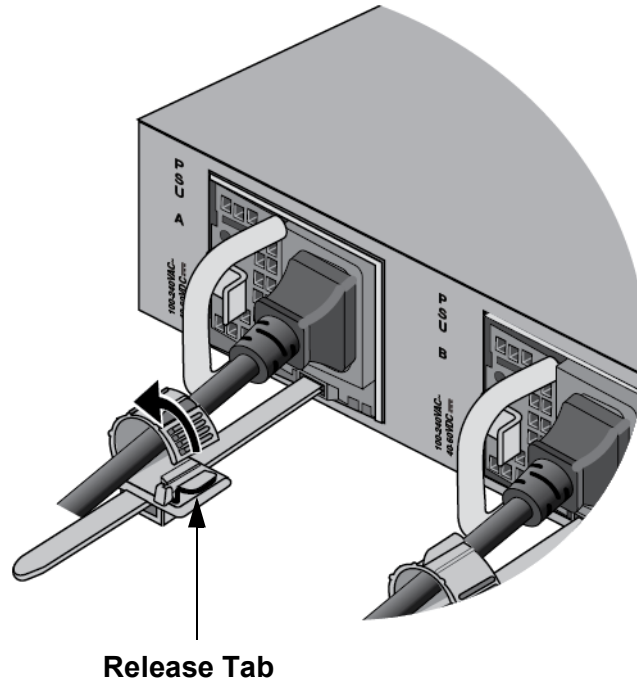

Figure 130. Opening the Restraining Strap on the Power Supply

3. Disconnect the power cord from the power supply. Refer to Figure 131.

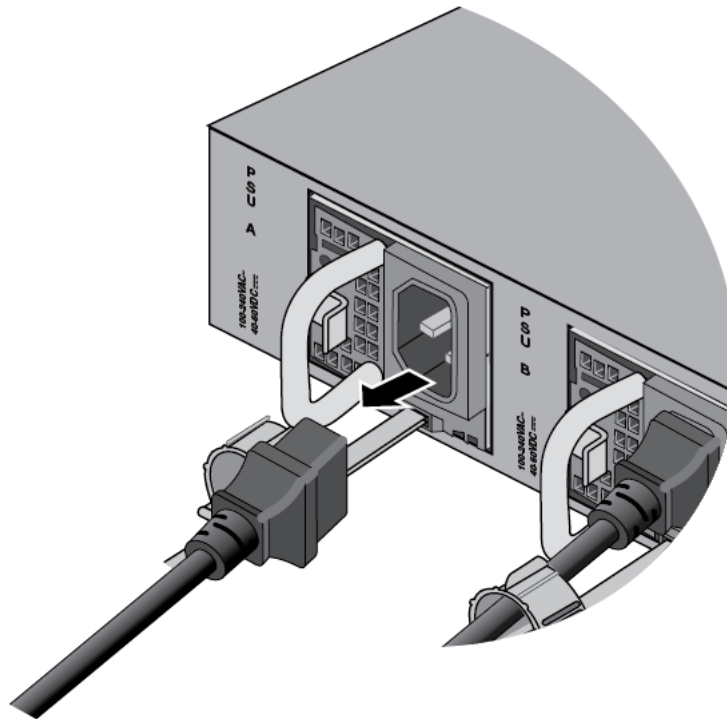

Figure 131. Disconnecting the Power Cord from the Power Supply

4. Press the release lever to the right and pull on the handle to release the power supply from the internal connector in the switch.

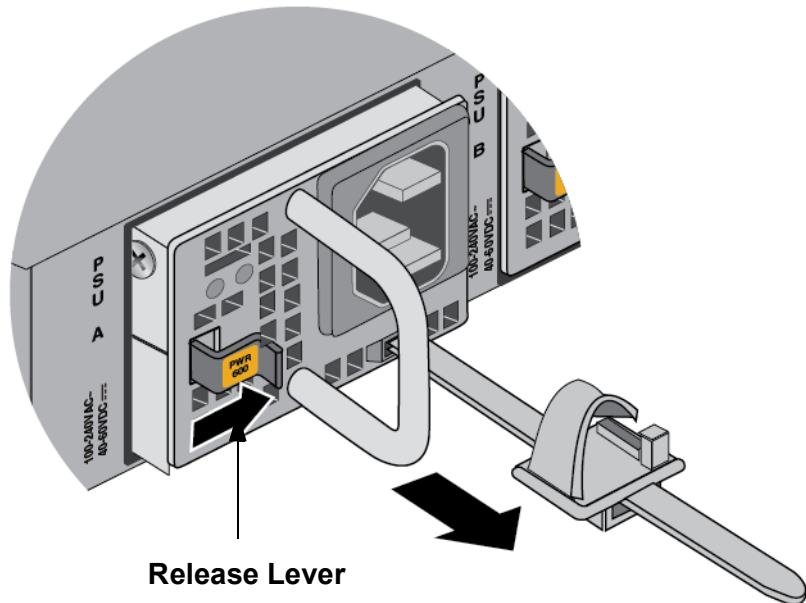

Figure 132. Removing the Power Supply

5. Carefully slide the power supply from the switch. Refer to Figure 133 on page 192.



Caution

The device is heavy. Use both hands to lift it. You might injure yourself or damage the device if you drop it. E94

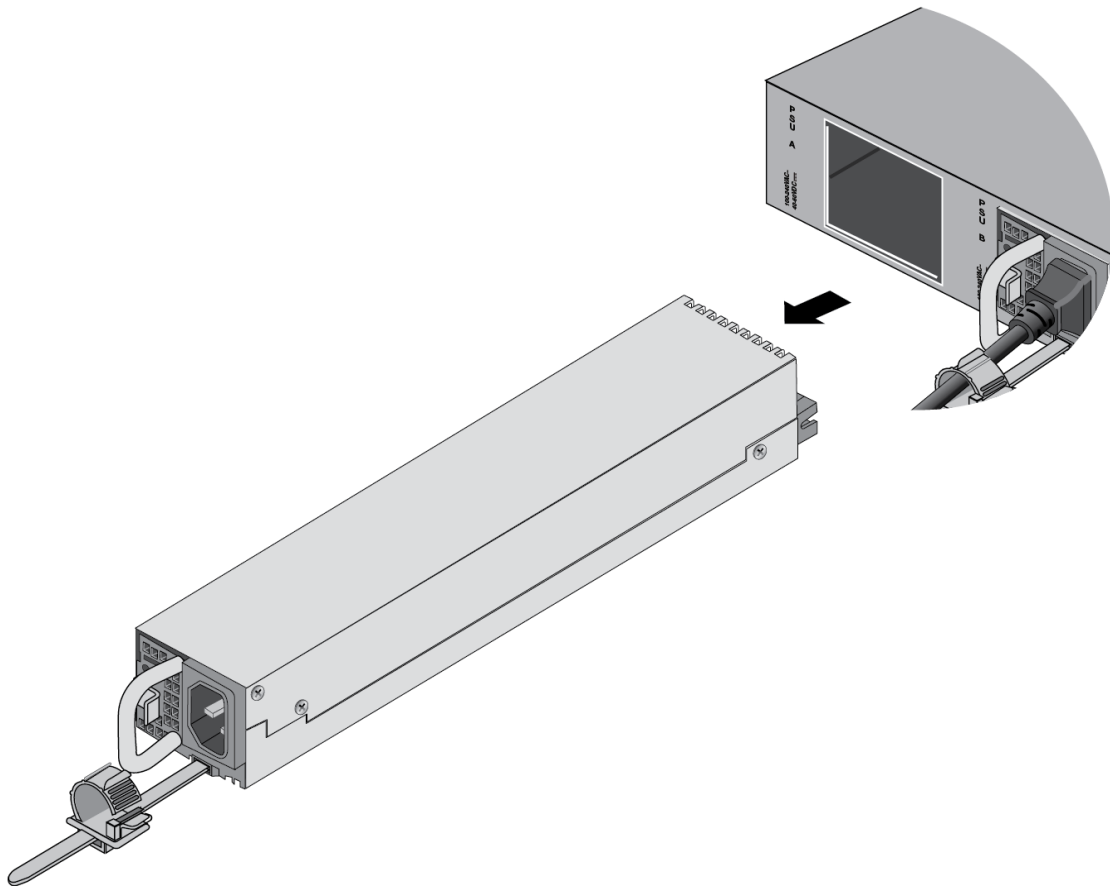

Figure 133. Removing a Power Supply

6. Do one of the following:
 - To install a new power supply, refer to “Installing PWR600 AC Power Supplies” on page 86 or “Replacing PWR600 DC Power Supplies” on page 194 for instructions.
 - If you are not installing a new power supply, continue with the next step to install the blank panel.
7. Orient the blank power supply cover as shown in Figure 134 on page 193 and slide it into the slot until it clicks into place.

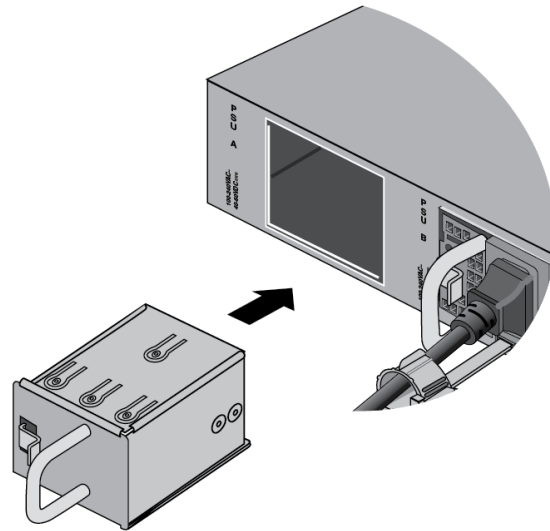

Figure 134. Installing the Blank Power Supply Cover

Replacing PWR600 DC Power Supplies

This section contains the procedure for removing or replacing PWR600 DC Power Supplies.

Note

Allied Telesis recommends saving a backup copy of the configuration file in the switch before removing or replacing power supplies. For instructions, refer to the *Software Reference for x950 Switch, AlliedWare Plus Operating System*.

To remove DC power supplies from the switch, perform the following procedure:

1. Power off the DC power supply.
2. Loosen the screw for the connector panel with a Phillips-head screwdriver. Refer to Figure 135.

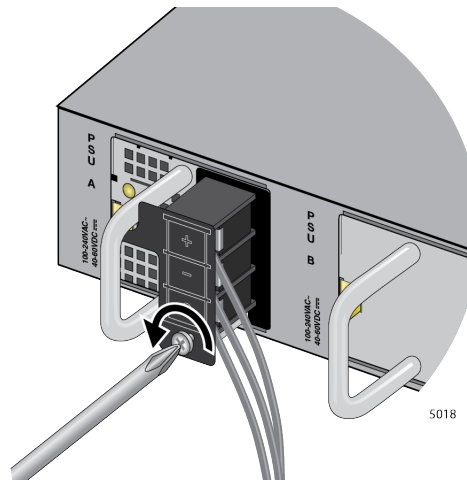

Figure 135. Loosening the Screw for the Panel

3. Press the panel to the right to access the connecting screws as shown in Figure 136 on page 195.

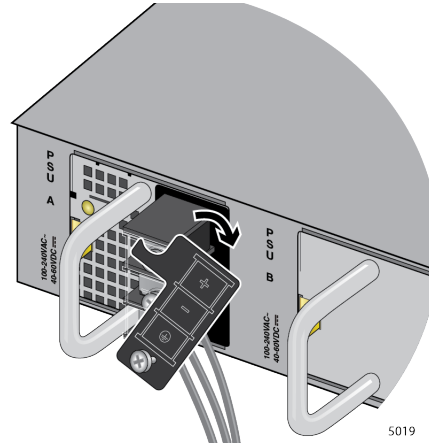

Figure 136. Accessing the Connecting Screws

4. Loosen all three screws for the ground wire, positive (+) and negative (-) wires.
5. Remove all three wires.
6. Press the release lever to the right and pull on the handle to release the power supply from the internal connector in the switch. Refer to Figure 132 on page 191.

The release lever and handle are shown in Figure 137.

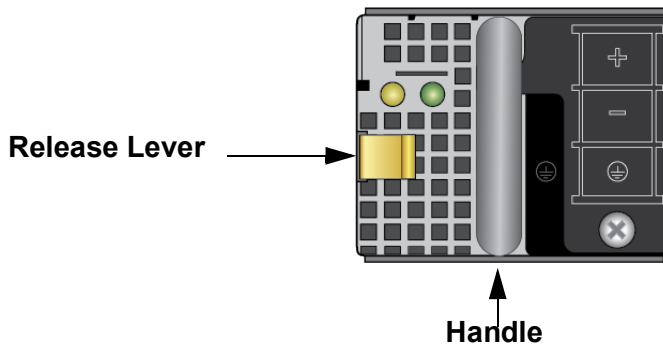

Figure 137. Front Panel of the PWR600 DC Power Supply

7. Carefully slide the power supply from the switch. Refer to Figure 138 on page 196.



Caution

The device is heavy. Use both hands to lift it. You might injure yourself or damage the device if you drop it. E94

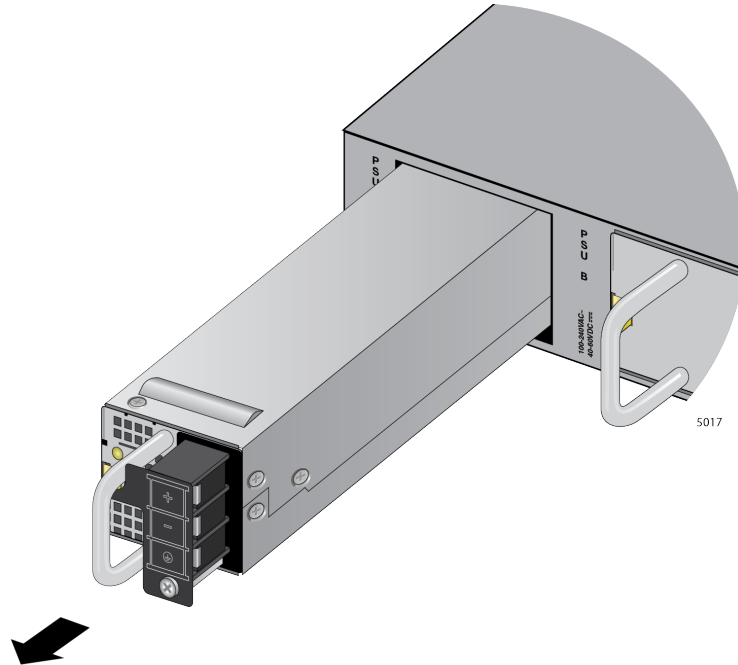

Figure 138. Removing a DC Power Supply

8. Do one of the following:
 - To install a new power supply, refer to “Installing PWR600 AC Power Supplies” on page 86 or “Installing PWR600 DC Power Supplies” on page 90 for instructions.
 - If you are not installing a new power supply, continue with the next step to install the blank panel.
9. Orient the blank power supply cover as shown in Figure 134 on page 193 and slide it into the slot until it clicks into place.
10. Remove the ground wire from the ground point at the installation site.

Replacing FAN05 Modules

This section contains the procedure for replacing FAN05 Modules. Fan modules are hot swappable. You can replace them without having to power off the switch. For background information, refer to “FAN05 Cooling Fan” on page 41.

Note

Allied Telesis recommends saving a backup copy of the configuration file in the switch before replacing a fan module. For instructions, refer to the Software Reference for x950 Switches.

Removing Fan Modules

This procedure requires the following tool:

- #2 Phillips-head screwdriver (not provided)

The illustrations show the removal of the fan module from FAN B slot on the back panel. The procedure is the same for removing a module from FAN A slot.

To remove a fan module from the switch, perform the following procedure:

1. Use a #2 Phillips-head screwdriver to loosen the two screws on the faceplate of the fan module. Refer to Figure 139.

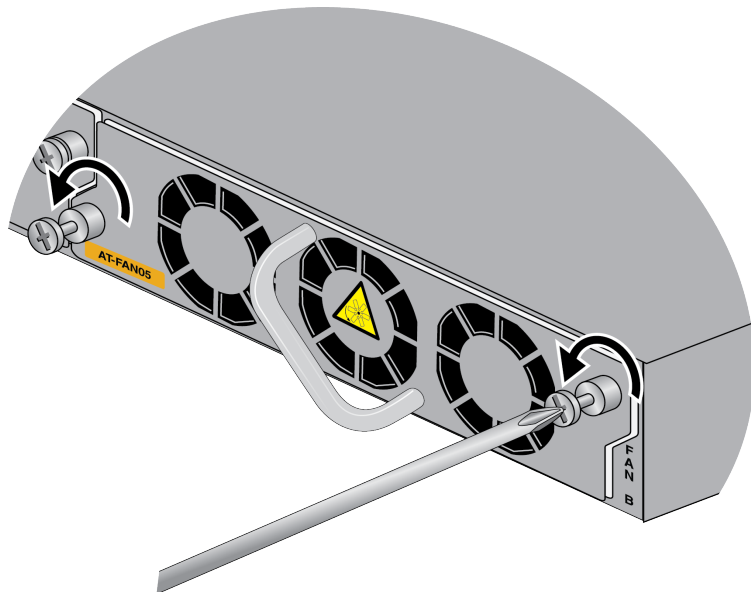

Figure 139. Loosening the Screws on the Fan Module

2. Carefully pull on the handle to disconnect the line card from the internal connector in the switch. Refer to Figure 140.

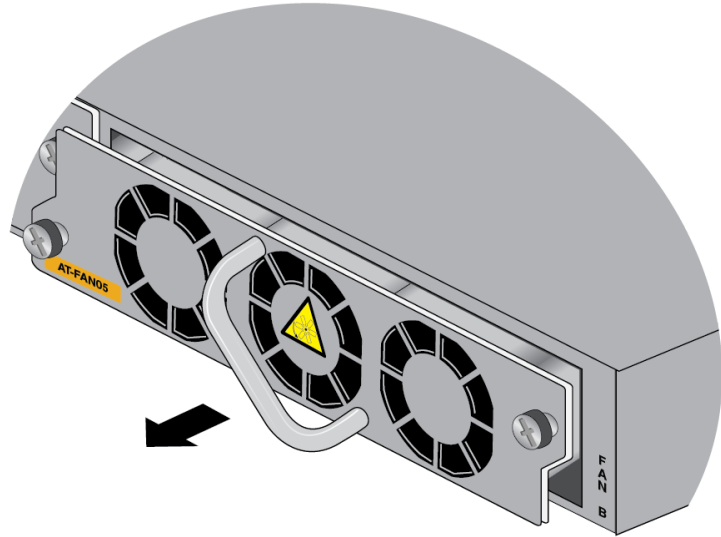

Figure 140. Disconnecting the FAN05 Module from the Switch

3. Slide the fan module out of the switch. Refer to Figure 141.

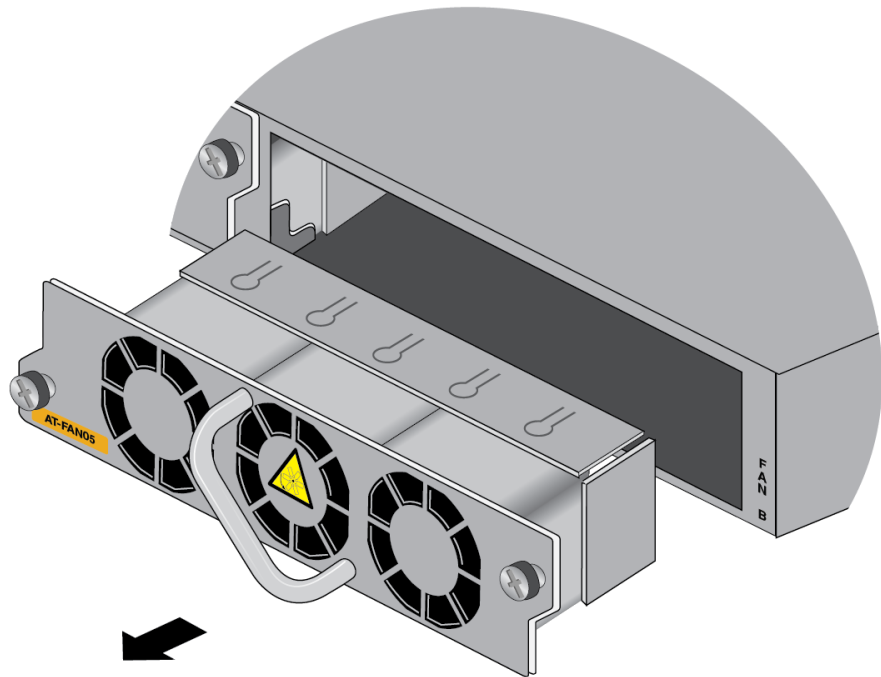

Figure 141. Sliding the Fan Module from the Switch

4. Continue with the next procedure to install a new FAN05 Module.

Installing Fan Modules

This procedure requires the following tool:

- #2 Phillips-head screwdriver (not provided)

The illustrations show the installation of a fan module in FAN B slot on the back panel. The procedure is the same for installing a module in FAN A slot.

To install a fan module, perform the following procedure:

1. Remove the new fan module from its shipping box. Refer to Figure 142.

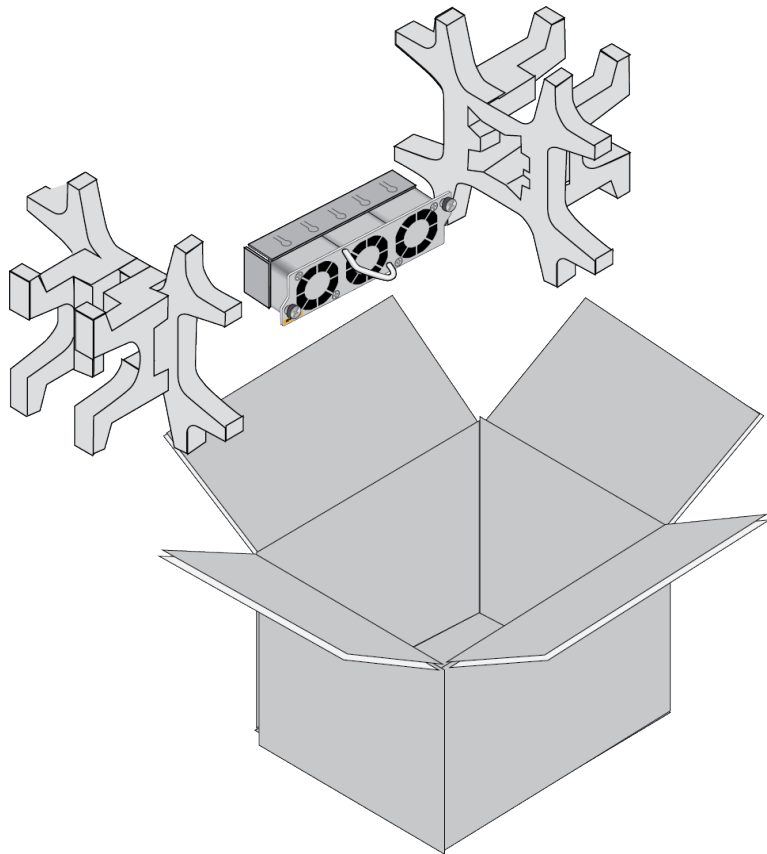

Figure 142. Removing the Fan Module from the Shipping Container

2. Align the fan module in the slot. Refer to Figure 143 on page 200.

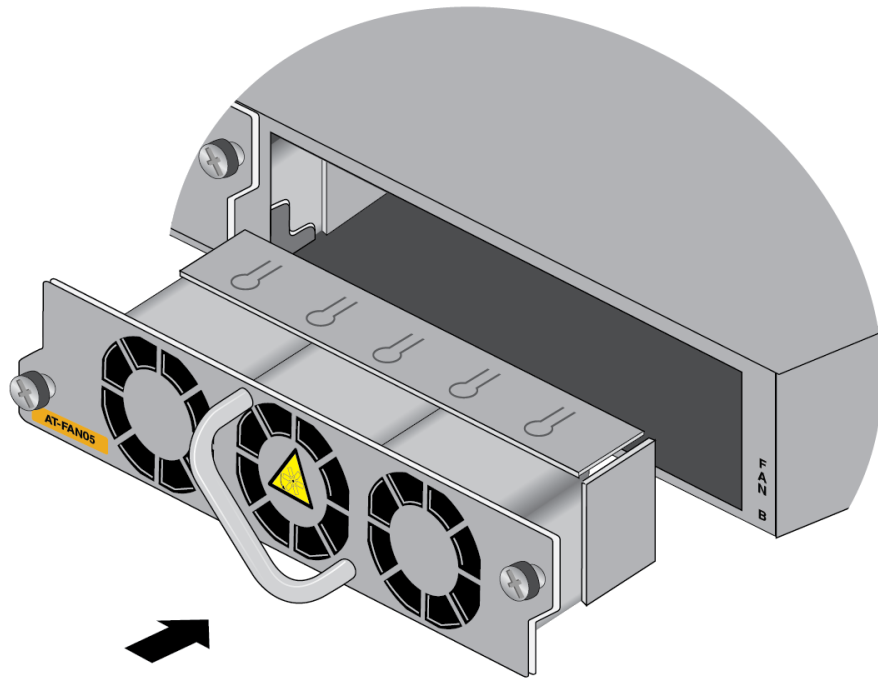

Figure 143. Aligning the FAN05 Module in the Switch Slot

3. When you feel the module make contact with the internal connector, gently press on both sides to seat the module on the connector. Refer to Figure 144.

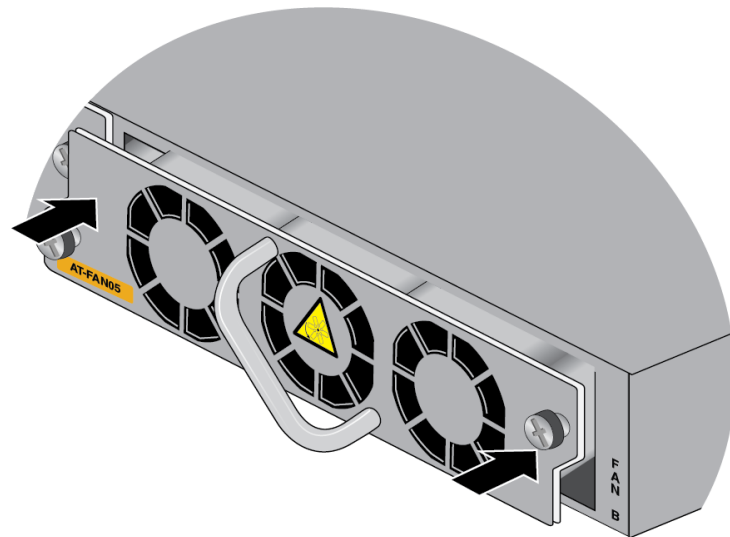

Figure 144. Seating the FAN05 Module on the Internal Connector

4. Tighten the two screws on the module to secure it to the switch. Refer to Figure 145.

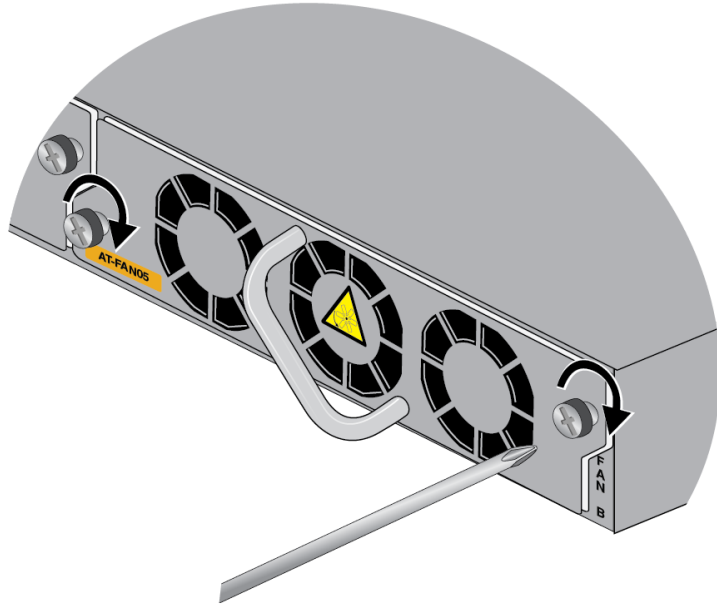

Figure 145. Tightening the Two Captive Screws on the FAN05 Module

5. To confirm the operations of the new fan module, start a local or remote management session and enter the `SHOW SYSTEM ENVIRONMENT` command in the User Exec or Privileged Exec mode. For directions, refer to “Verifying the Switch with AlliedWare Plus Commands” on page 164.

Chapter 12

Troubleshooting

This chapter contains suggestions on how to troubleshoot problems with the switch.

Note

For further assistance, please contact Allied Telesis Technical Support at www.alliedtelesis.com/support.

Problem 1: The unit is not receiving power. All the port LEDs and Switch ID LED are off, and the fans are not operating.

Solutions: Try the following:

- Verify that the power cord is securely connected to the power source and AC connector on the back panel of the switch.
- Verify that the DC power wires are securely connected to the screws on the front panel and to the DC power source unit.
- Verify that the power outlet has power by connecting another device to it.
- Try connecting the unit to another power source.
- Try a different power cord.
- Verify that the voltage from the power source is within the required levels for your region. The power requirements for the switch are listed in “Power Specifications” on page 215.
- Try replacing the power supply.

Note

Power supplies are hot swappable. If the chassis has two power supplies and one fails, you can replace the failed unit without having to power off the operational power supply.

Problem 2: All the port LEDs are off even though the ports are connected to active network devices.

Solution: The switch might be operating in the low power mode. To toggle on the LEDs, press the eco-friendly button on the front panel of the switch. You can also toggle the LEDs off and on with the ECOFRIENDLY LED and NO ECOFRIENDLY LED commands in the command line interface.

Problem 3: A 1Gbps or 10Gbps fiber optic transceiver in a base port (ports 1 to 24 for the x950-28XSQ switch, or port 1 to 48 for the x950-52XSQ switch) is unable to establish a link to a network device.

Solutions: Try the following:

- ❑ Check that the transceiver is fully inserted in the port.
- ❑ Verify that the fiber optic cable is securely connected to the port on the transceiver and the remote network device.
- ❑ Verify that the remote network device is operating properly.
- ❑ Verify that the operating specifications of the fiber optic ports on the transceiver and remote network device are compatible.
- ❑ Verify that the correct type of fiber optic cabling is being used.
- ❑ Verify that the port is connected to the correct fiber optic cable.
- ❑ Try connecting another network device to the fiber optic port using a different cable. If the port is able to establish a link, then the problem is with the cable or with the other network device.
- ❑ Use the switch's management software to verify that the port is enabled.
- ❑ If the remote network device is a managed device, use its management firmware to determine whether its port is enabled.
- ❑ If the problem is with two BiDi (bi-directional) transceivers, refer to their data sheets to verify that their transmission and reception frequencies are opposite each other. For instance, a BiDi transceiver that transmits and receives at 1310nm and 1550nm, respectively, has to be connected to a transceiver that transmits and receives at 1550nm and 1310nm, respectively. Two BiDi transceivers will not establish a link if they transmit and receive at the same frequencies.
- ❑ Test the attenuation of both directions on the fiber optic cable with a fiber optic tester to determine whether the optical signal is too weak or strong.

Problem 4: A 40Gbps or 100Gbps fiber optic transceiver in port 25, 29, 33, or 37 on the x950-28XSQ or x950-28XTQm switch or port 49, 53, 57, or 61 on the x950-52XSQ or x950-52XTQm switch cannot establish a link with a network device.

Solutions: Try the following:

- ❑ Review the solutions in Problem 3.
- ❑ Use the SHOW PLATFORM command to confirm that the port is configured correctly for an 100Gbps fiber optic transceiver. If necessary, perform "Configuring Ports for 40Gbps QSFP+ or 100Gbps QSFP28 Transceivers, or Breakout Cables" on page 168.

Changing a port from a 40Gbps transceiver or breakout cable to a 100Gbps transceiver requires resetting the switch. The same is also true when replacing a 100Gbps transceiver with a 40Gbps transceiver or breakout cable.

- ❑ If the problem is with an 100Gbps transceiver, you might need to adjust the Forward Error Correction (FEC) parameter on the port, with the FEC command. Refer to the *Software Reference for x950 Switch, AlliedWare Plus Operating System*.

Problem 5: A 4x10Gbps breakout cable in port 25, 29, 33, or 37 on the x950-28XSQ or x950-28XTQm switch, or port 49, 53, 57, or 61 on the x950-52XSQ or x950-52XTQm switch cannot establish links with network devices.

Solutions: Try the following:

- ❑ Check that the cable is fully inserted in the port in the switch.
- ❑ Verify that the breakout cables are securely connected to the ports on the network devices.
- ❑ Use the SHOW PLATFORM command to confirm that the port is configured for a breakout cable. If necessary, perform “Configuring Ports for 40Gbps QSFP+ or 100Gbps QSFP28 Transceivers, or Breakout Cables” on page 168.
- ❑ If the port previously had a 100Gbps transceiver, you must reset the switch after configuring it for a breakout cable.

Problem 6: An XEM2 line card in the expansion slot is not functioning.

Solutions: Try the following:

- ❑ Visually inspect the card to verify that it is fully inserted into the expansion slot.
- ❑ If the problem is with an XEM2-12XTm Card, the switch might have an earlier version of the AlliedWare Plus software that does not support the card. The card requires v5.4.9-1 or later. Use the SHOW VERSION command to display the version number. If necessary, update the management software.
- ❑ Try installing the card in a different switch. If it still does not work, the problem is probably with the card. Replace the card.
- ❑ Try installing a different card in the switch. If the replacement card fails to work, the problem is probably with the switch. Contact your Allied Telesis sales representative for assistance.

Problem 7: An SFP, SFP+, or QSFP+ transceiver in an XEM2 line card is unable to establish a link to another network device.

Solutions: Try the solutions to Problem 3.

Problem 8: A twisted pair port on x950-28XTQm or x950-52XTQm switches, or the XEM2-12XT or XEM2-12XTm Line Card cannot establish a link with a network device.

Solutions: Try the following:

- ❑ Verify that the network device connected to the twisted pair port is powered on and is operating properly.
- ❑ Verify that the network device operates at a speed supported by the card. The ports on the XEM2-12XT Card support 100Mbps and 1/10Gbps. The ports on the x950-28XTQm and x950-52XTQm switch, and XEM2-8XSTm and XEM2-12XTm Cards support 100Mbps and 1/2.5/5/10Gbps. The cards do not support 10Mbps devices.
- ❑ If the XEM2-12XT Card cannot establish links with 100Mbps devices, the switch might have an earlier version of the AlliedWare Plus management software. Support for 100Mbps devices on the XEM2-12XT Card was added in version 5.4.9-1. Use the SHOW VERSION command to display the version number. If necessary, update the management software.
- ❑ Try connecting another network device to the twisted pair port with a different cable. If the twisted pair port is able to establish a link, then the problem is with the cable or the other network device.
- ❑ Verify that the twisted pair cable does not exceed 100 meters (328 feet).
- ❑ Verify that you are using the appropriate category of twisted pair cable. Cable requirements are listed in “Cabling Twisted Pair Ports” on page 172.
- ❑ Verify that the port is connected to the correct twisted pair cable.

Note

An 1GBase/10GBase connection may require five to ten seconds to establish a link.

Problem 9: The switch overheats and shuts down.

Solutions: Try the following:

- ❑ Verify that the location of the switch allows for adequate airflow.
- ❑ If the switch is operating, use the SHOW SYSTEM ENVIRONMENT command in the Privileged Exec mode to verify that the power supplies and fan modules are operating properly.

Problem 10: The switch functions intermittently.

Solutions: Try the following:

- ❑ Use the SHOW SYSTEM ENVIRONMENT command in the Privileged Exec mode to verify that the input voltage from the power source to the switch is stable and within the approved operating range. The unit will shut down if the input voltage fluctuates above or below the approved operating range.
- ❑ Use the SHOW SYSTEM ENVIRONMENT command to verify that the fan modules are operating correctly.
- ❑ Verify that the location of the switch allows for adequate airflow. The unit will shut down if it is overheating.

Problem 11: The Switch ID LED in the management panel is flashing “F.”

Solutions: One of the following problems has occurred:

- ❑ A cooling fan has failed.
- ❑ The internal temperature of the switch is outside the normal operating range and the unit might shut down.

Contact your Allied Telesis sales representative for assistance.

Appendix A

Technical Specifications

This appendix contains the following sections:

- "Physical Specifications" on page 210
- "Environmental Specifications" on page 214
- "Power Specifications" on page 215
- "Certifications" on page 225
- "RJ-45 Twisted Pair Port Pinouts" on page 226
- "RJ-45 Style Serial Console Port Pinouts" on page 228

Physical Specifications

Dimensions (H x W x D)

Table 33 lists the dimensions of the switches and power supplies.

Table 33. Product Dimensions

x950-28XSQ x950-28XTQm	4.4 cm x 44.0 cm x 44.5 cm (1.7 in. x 17.3 in. x 17.5 in.)
x950-52XSQ x950-52XTQm	4.4 cm x 44.0 cm x 44.7 cm (1.7 in. x 17.3 in. x 17.6 in.)
XEM2-8XSTm Line Card XEM2-12XT Line Card XEM2-12XTm Line Card XEM2-12XS Line Card XEM2-12XS v2 Line Card XEM2-4QS Line Card XEM2-1CQ Line Card	4.0 x 13.0 x 16.6 cm (1.57 x 5.11 x 6.53 in.)
PWR600 AC	5.1 cm x 4.0 cm x 24.5 cm (2.0 in. x 1.6 in. x 9.6 in.)
PWR600 DC	5.1 cm x 4.0 cm x 24.5 cm (2.0 in. x 1.6 in. x 9.6 in.)
FAN05	4.3 cm x 15.2 cm x 10.0 cm (1.7 in. x 6.0 in. x 3.9 in.)

Width (All Models)

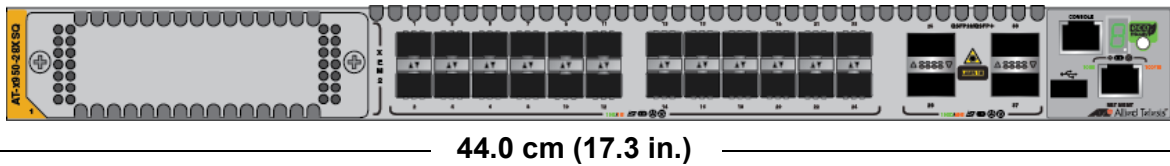

Height (All Models)

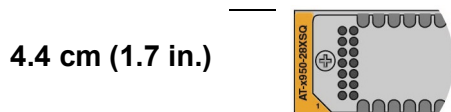
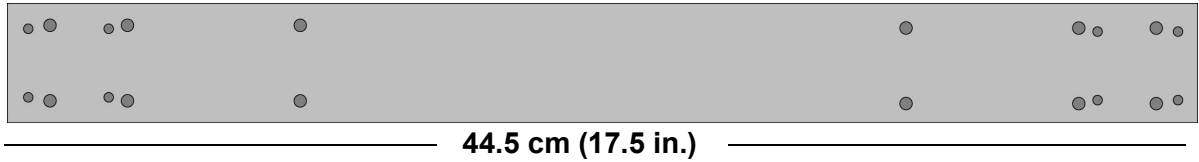

Figure 146. Switch Width and Height

The side dimension and locations of the bracket holes for the x950-28XSQ and x950-28XTQm switches are shown in Figure 147.

Depth (x950-28XSQ and x950-28XTQm)



Bracket Hole Locations (x950-28XSQ and x950-28XTQm)

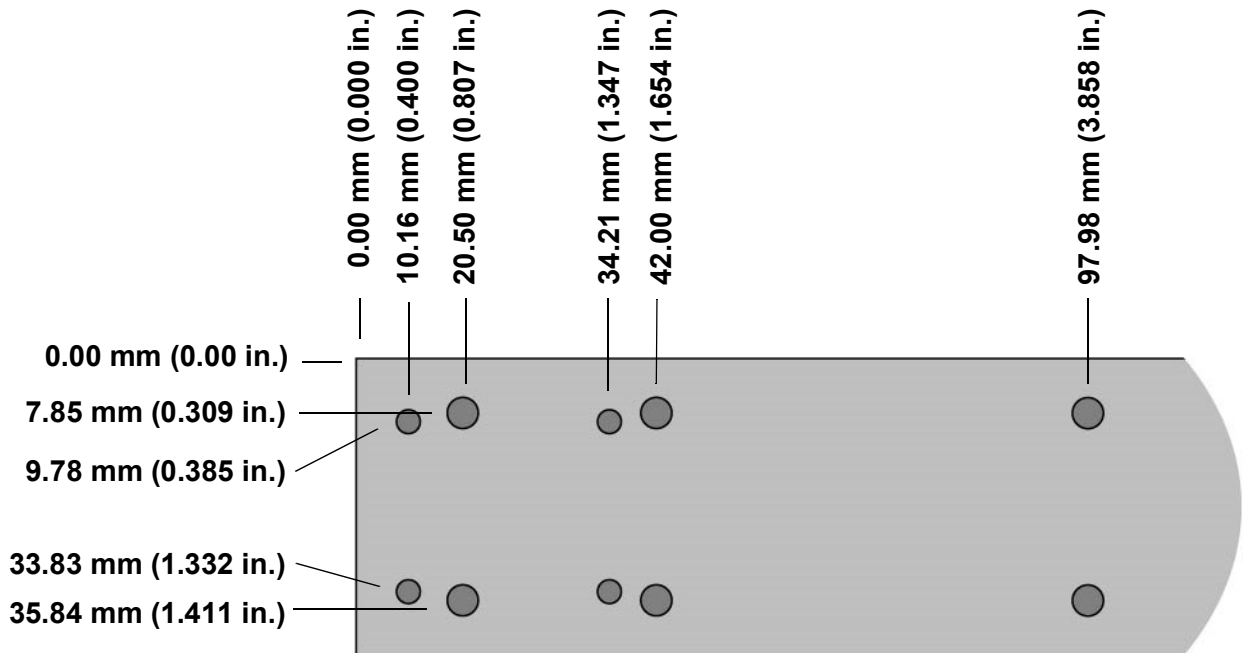
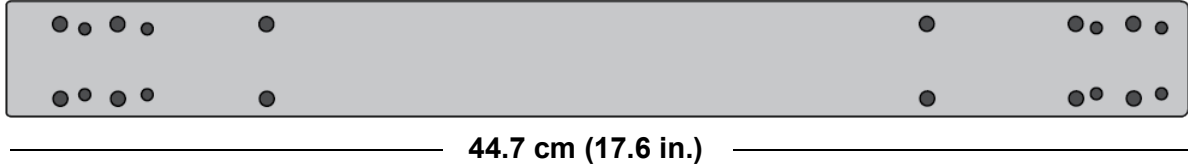

Figure 147. Switch Depth and Locations of Bracket Holes for the x950-28XSQ and x950-28XTQm Switches

The side dimension and bracket holes for the x950-52XSQ and x950-52XTQm Switches are shown in Figure 148 on page 212.

Depth (x950-52XSQ and x950-52XTQm)



Bracket Hole Locations (x950-52XSQ and x950-52XTQm)

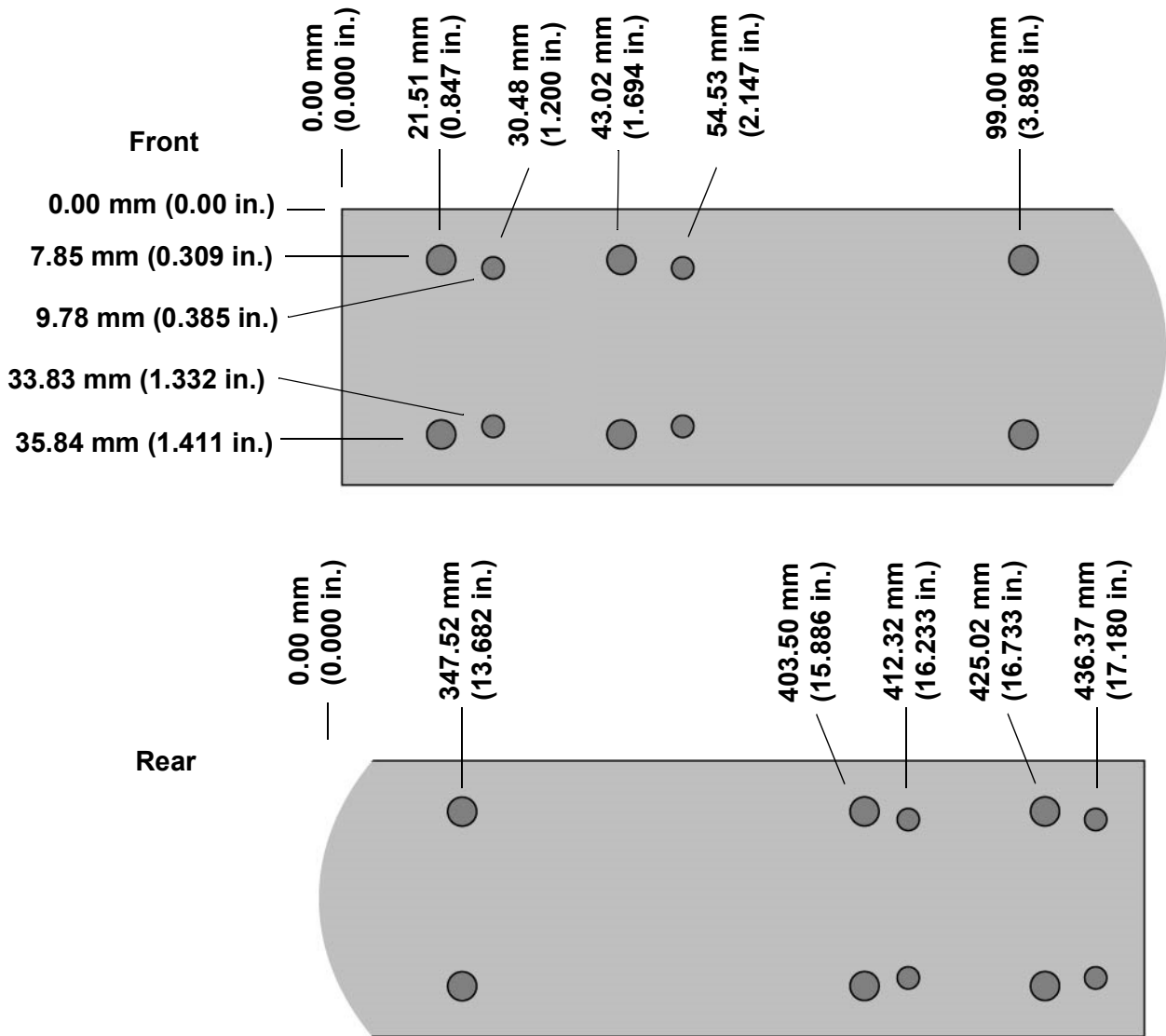

Figure 148. Switch Depth and Bracket Holes for x950-52XSQ and x950-52XTQm Switches

Weights

Table 34 lists the weights of the switches and components.

Table 34. Product Weights

x950-28XSQ Switch	7.21 kg (15.90 lb.)
x950-28XTQm Switch	7.33 kg (16.15 lb.)
x950-52XSQ Switch	7.35 kg (16.2 lb.)
x950-52XTQm Switch	8.20 kg (18.08 lb.)
XEM2-8XSTm Line Card	0.70 kg (1.54 lb.)
XEM2-12XT Line Card	0.75 kg (1.65 lb.)
XEM2-12XTm Line Card	1.04 kg (2.3 lb.)
XEM2-12XS Line Card	0.75 kg (1.65 lb.)
XEM2-12XS v2 Line Card	0.73 kg (1.60 lb.)
XEM2-4QS Line Card	0.66 kg (1.45 lb.)
XEM2-1CQ Line Card	0.62 kg (1.37 lb.)
PWR600 AC	0.68 kg (1.5 lb.)
PWR600 DC	0.77 kg (1.7 lb.)
FAN05	0.34 kg (0.75 lb.)

The weights of the switches include two cooling fan modules. They do not include power supplies or line card.

Ventilation

Table 35 lists the ventilation requirements.

Table 35. Ventilation Requirements

Recommended Minimum Ventilation on All Sides	10 cm (4.0 in)
--	----------------

Environmental Specifications

Table 36 lists the environmental specifications of the switches.

Table 36. Environmental Specifications

Operating Temperature (with QSFP28 transceivers)	0° C to 45° C (32° F to 113° F)
Operating Temperature (without QSFP28 transceivers)	0° C to 50° C (32° F to 122° F)
Storage Temperature	-25° C to 70° C (-13° F to 158° F)
Operating Humidity	5% to 90% noncondensing
Storage Humidity	5% to 95% noncondensing
Maximum Operating Altitude	3,000 m (9,842 ft)
Maximum Nonoperating Altitude	4,000 m (13,100 ft)

Power Specifications

This section contains the maximum power consumption values and input voltages.

Maximum Power Consumptions

Table 37 lists the maximum power consumptions for the x950-28XSQ Switch.

Table 37. Maximum Power Consumptions (Watts) for the x950-28XSQ Switch

x950-28XSQ Switch and Line Card	PWR600	Number of Power Supplies	Maximum Power Consumption
Switch - No card	AC	1	206.08 W
		2	231.22 W
	DC	1	201.85 W
		2	218.66 W
Switch plus XEM2-4QS Card	AC	1	224.55 W
		2	248.04 W
	DC	1	219.80 W
		2	236.11 W
Switch plus XEM2-12XT Card	AC	1	251.07 W
		2	271.85 W
	DC	1	246.27 W
		2	261.69 W
Switch plus XEM2-12XS Card	AC	1	240.40 W
		2	262.30 W
	DC	1	235.66 W
		2	251.44W

Table 37. Maximum Power Consumptions (Watts) for the x950-28XSQ Switch
(Continued)

x950-28XSQ Switch and Line Card	PWR600	Number of Power Supplies	Maximum Power Consumption
Switch plus XEM2-1CQ Card	AC	1	213.63 W
		2	238.19 W
	DC	1	209.36 W
		2	226.04 W
Switch plus XEM2-12XTm Card	AC	1	239.96 W
		2	261.64 W
	DC	1	233.73 W
		2	249.67 W
Switch plus XEM2-12XS v2 Card	AC	1	233.38 W
		2	256.32 W
	DC	1	227.97 W
		2	244.19 W
Switch plus XEM2-8XSTm Card	AC	1	226.71 W
		2	250.27 W
	DC	1	221.56 W
		2	237.91 W

Table 38 lists the maximum power consumptions for the x950-28XTQm Switch.

Table 38. Maximum Power Consumptions (Watts) for the x950-28XTQm Switch

x950-28XTQm Switch and Line Card	PWR600	Number of Power Supplies	Maximum Power Consumption
Switch - No card	AC	1	234.55 W
		2	255.26 W
	DC	1	222.55 W
		2	238.80 W
Switch plus XEM2-4QS Card	AC	1	253.19 W
		2	271.68 W
	DC	1	240.59 W
		2	256.15 W
Switch plus XEM2-12XT Card	AC	1	280.51 W
		2	295.82 W
	DC	1	267.19 W
		2	281.79 W
Switch plus XEM2-12XS Card	AC	1	269.62 W
		2	286.18 W
	DC	1	256.71 W
		2	271.49 W
Switch plus XEM2-1CQ Card	AC	1	241.95 W
		2	261.74 W
	DC	1	230.07 W
		2	246.02 W

Table 38. Maximum Power Consumptions (Watts) for the x950-28XTQm Switch (Continued)

x950-28XTQm Switch and Line Card	PWR600	Number of Power Supplies	Maximum Power Consumption
Switch plus XEM2-12XTm Card	AC	1	267.89 W
		2	284.63 W
	DC	1	254.83 W
		2	269.90 W
Switch plus XEM2-12XS v2 Card	AC	1	261.97 W
		2	280.37 W
	DC	1	248.92 W
		2	264.26 W
Switch plus XEM2-8XSTm Card	AC	1	255.31 W
		2	273.90 W
	DC	1	242.46 W
		2	258.15 W

Table 39 lists the maximum power consumptions for the x950-52XSQ Switch.

Table 39. Maximum Power Consumptions (Watts) for the x950-52XSQ Switch

	PWR600	Number of Power Supplies	Maximum Power Consumption
x950-52XSQ Switch	AC	1	246.26 W
		2	266.12 W
	DC	1	229.90 W
		2	247.40 W

Table 40 lists the maximum power consumptions for the x950-52XTQm Switch.

Table 40. Maximum Power Consumptions (Watts) for the x950-52XTQm Switch

	PWR600	Number of Power Supplies	Maximum Power Consumption
x950-52XTQm Switch	AC	1	274.04 W
		2	291.09 W
	DC	1	263.10 W
		2	273.30 W

Typical Power Savings in eco-friendly Mode

Table 41 lists the typical power savings in eco-friendly mode for the x950-28XSQ Switch.

Table 41. Typical Power Savings in eco-friendly Mode (Watts) for the x950-28XSQ Switch

x950-28XSQ Switch and Line Card	Power Savings
Switch - No card	0.53 W
Switch plus XEM2-4QS Card	0.64 W
Switch plus XEM2-12XT Card	0.64 W
Switch plus XEM2-12XS Card	0.66 W
Switch plus XEM2-1CQ Card	0.55 W
Switch plus XEM2-12XTm Card	0.64 W
Switch plus XEM2-12XS v2 Card	0.84 W
Switch plus XEM2-8XSTm Card	0.81 W

Table 42 lists the typical power savings in eco-friendly mode for the x950-28XTQm Switch.

Table 42. Typical Power Savings in eco-friendly Mode (Watts) for the x950-28XTQm Switch

x950-28XTQm Switch and Line Card	Power Savings
Switch - No card	0.73 W
Switch plus XEM2-4QS Card	0.84 W
Switch plus XEM2-12XT Card	0.84 W
Switch plus XEM2-12XS Card	0.86 W
Switch plus XEM2-1CQ Card	0.75 W
Switch plus XEM2-12XTm Card	0.84 W
Switch plus XEM2-12XS v2 Card	0.84 W
Switch plus XEM2-8XSTm Card	0.81 W

Input Voltage

Table 43 lists the input voltage for the power supply.

Table 43. Input Voltages

	AC	DC
x950-28XSQ Switch	100-240 VAC~, 4A maximum, 50/60 Hz (per inputx2)	40-60V DC, 6.0A (per Input x2)
x950-28XTQm Switch	100-240 VAC~, 4A maximum, 50/60 Hz (per inputx2)	40-60V DC, 6.0A (per Input x2)
x950-52XSQ Switch	100-240 VAC~, 4A maximum, 50/60 Hz (per inputx2)	40-60V DC, 6.0A (per Input x2)
x950-52XTQm Switch	100-240 VAC~, 4A maximum, 50/60 Hz (per inputx2)	40-60V DC, 6.0A (per Input x2)
PWR600 AC	100-240 VAC~, 8.7A maximum, 50/60 Hz (per input)	N/A
PWR600 DC	N/A	40-72 VDC, 6.0A maximum

Maximum Power Supply Efficiency

Table 44 lists the maximum power supply efficiency.

Table 44. Maximum Power Supply Efficiency (Based on 100V Input Voltage)

PWR600 AC Power Supply	Up to 85%
------------------------	-----------

Heat Dissipations

Table 45 lists the heat dissipations for the x950-28XSQ Switch.

Table 45. Heat Dissipations for the x950-28XSQ Switch

x950-28XSQ Switch and Line Card	PWR600	Number of Power Supplies	Heat Dissipation (British Thermal Units/Hour)
Switch - No card	AC	1	703.24 BTU/hr
		2	789.03 BTU/hr
	DC	1	688.80 BTU/hr
		2	746.16 BTU/hr
Switch plus XEM2-4QS Card	AC	1	766.27 BTU/hr
		2	846.43 BTU/hr
	DC	1	750.05 BTU/hr
		2	805.71 BTU/hr
Switch plus XEM2-12XT Card	AC	1	856.77 BTU/hr
		2	927.68 BTU/hr
	DC	1	840.40 BTU/hr
		2	893.01 BTU/hr
Switch plus XEM2-12XS Card	AC	1	820.36 BTU/hr
		2	895.09 BTU/hr
	DC	1	804.17 BTU/hr
		2	858.03 BTU/hr

Table 45. Heat Dissipations for the x950-28XSQ Switch (Continued)

x950-28XSQ Switch and Line Card	PWR600	Number of Power Supplies	Heat Dissipation (British Thermal Units/Hour)
Switch plus XEM2-1CQ Card	AC	1	729.01 BTU/hr
		2	812.82 BTU/hr
	DC	1	714.43 BTU/hr
		2	771.36 BTU/hr
Switch plus XEM2-12XTm Card	AC	1	818.86 BTU/hr
		2	892.84 BTU/hr
	DC	1	797.61 BTU/hr
		2	851.99 BTU/hr
Switch plus XEM2-12XS v2 Card	AC	1	796.40 BTU/hr
		2	874.69 BTU/hr
	DC	1	777.95 BTU/hr
		2	833.31 BTU/hr
Switch plus XEM2-8XSTm Card	AC	1	773.64 BTU/hr
		2	854.04 BTU/hr
	DC	1	756.07 BTU/hr
		2	811.85 BTU/hr

Table 46 lists the heat dissipations for the x950-28XTQm Switch.

Table 46. Heat Dissipations for the x950-28XTQm Switch

x950-28XTQm Switch and Line Card	PWR600	Number of Power Supplies	Heat Dissipation (British Thermal Units/Hour)
Switch - No card	AC	1	800.40 BTU/hr
		2	871.07 BTU/hr
	DC	1	759.43 BTU/hr
		2	814.90 BTU/hr

Table 46. Heat Dissipations for the x950-28XTQm Switch (Continued)

x950-28XTQm Switch and Line Card	PWR600	Number of Power Supplies	Heat Dissipation (British Thermal Units/Hour)
Switch plus XEM2-4QS Card	AC	1	864.01 BTU/hr
		2	927.10 BTU/hr
	DC	1	821.00 BTU/hr
		2	874.12 BTU/hr
Switch plus XEM2-12XT Card	AC	1	957.23 BTU/hr
		2	1009.48 BTU/hr
	DC	1	911.79 BTU/hr
		2	961.62 BTU/hr
Switch plus XEM2-12XS Card	AC	1	920.07 BTU/hr
		2	976.58 BTU/hr
	DC	1	876.02 BTU/hr
		2	926.45 BTU/hr
Switch plus XEM2-1CQ Card	AC	1	825.65 BTU/hr
		2	893.18 BTU/hr
	DC	1	785.09 BTU/hr
		2	839.52 BTU/hr
Switch plus XEM2-12XTm Card	AC	1	914.17 BTU/hr
		2	971.29 BTU/hr
	DC	1	869.62 BTU/hr
		2	921.01 BTU/hr
Switch plus XEM2-12XS v2 Card	AC	1	893.97 BTU/hr
		2	956.76 BTU/hr
	DC	1	849.44 BTU/hr
		2	901.77 BTU/hr

Table 46. Heat Dissipations for the x950-28XTQm Switch (Continued)

x950-28XTQm Switch and Line Card	PWR600	Number of Power Supplies	Heat Dissipation (British Thermal Units/Hour)
Switch plus XEM2-8XSTm Card	AC	1	871.24 BTU/hr
		2	934.68 BTU/hr
	DC	1	827.40 BTU/hr
		2	880.92 BTU/hr

Table 47 list the heat dissipations for the x950-52XSQ Switch.

Table 47. Heat Dissipations for the x950-52XSQ Switch

	PWR600	Number of Power Supplies	Heat Dissipation (British Thermal Units/Hour)
x950-52XSQ Switch	AC	1	840.36 BTU/hr
		2	908.13 BTU/hr
	DC	1	784.53 BTU/hr
		2	844.25 BTU/hr

Table 48 list the heat dissipations for the x950-52XTQm Switch.

Table 48. Heat Dissipations for the x950-52XTQm Switch

	PWR600	Number of Power Supplies	Heat Dissipation (British Thermal Units/Hour)
x950-52XTQm Switch	AC	1	935.16 BTU/hr
		2	993.34 BTU/hr
	DC	1	897.82 BTU/hr
		2	932.63 BTU/hr

Certifications

Table 49 lists the product certificates.

Table 49. Product Certifications

EMI (Emissions)	FCC Class A CISPR 22 Class A EN 55032 Class A VCCI Class A ICES-003 Class A RCM
EMC (Immunity)	EN 55024 EN 61000-3-2 EN 61000-3-3
Electrical and Laser Safety	UL 60950-1 (cULUS) EN 62368-1 (TUV) EN 60825-1 (TUV)
RoHS	RoHS6

RJ-45 Twisted Pair Port Pinouts

Figure 149 illustrates the pin layout of the RJ-45 connectors on the following products:

- ❑ x950-28XTQm Switch
- ❑ x950-52XTQm Switch
- ❑ XEM2-8XSTm Line Card
- ❑ XEM2-12XT Line Card
- ❑ XEM2-12XTm Line Card

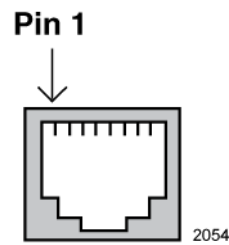

Figure 149. Pin Layout (Front View) of Twisted Pair Ports

Table 50 lists the pin signals at 100Mbps.

Table 50. Pin Signals on RJ-45 Twisted Pair Ports at 100Mbps

Pin	MDI Signal	MDI-X Signal
1	TX+	RX+
2	TX-	RX-
3	RX+	TX+
4	Not used	Not used
5	Not used	Not used
6	RX-	TX-
7	Not used	Not used
8	Not used	Not used

Table 51 lists the pin signals at 1/2.5/5/10Gbps.

Table 51. Pin Signals on Twisted Pair Ports at 1/2.5/5/10Gbps

Pin	Pair	Signal
1	1 +	TX and RX+
2	1 -	TX and RX-
3	2 +	TX and RX+
4	3 +	TX and RX+
5	3 -	TX and RX-
6	2 -	TX and RX-
7	4 +	TX and RX+
8	4 -	TX and RX-

RJ-45 Style Serial Console Port Pinouts

Table 52 lists the pin signals of the RJ-45 style serial Console port.

Table 52. RJ-45 Style Serial Console Port Pin Signals

Pin	Signal
1	Looped to pin 8.
2	Looped to pin 7.
3	Transmit Data
4	Ground
5	Ground
6	Receive Data
7	Looped to pin 2.
8	Looped to pin 1.