

1 2 3 4 5 6 7

REV.	DESCRIPTION	ENG.	APPROVAL

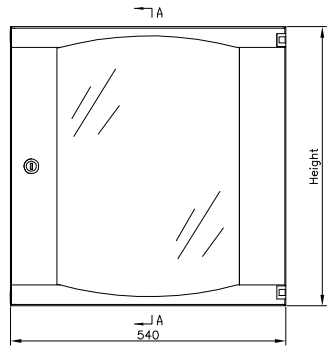

FRONT

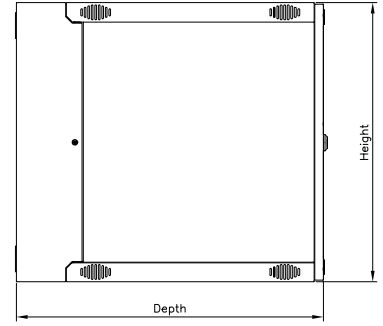

SIDE

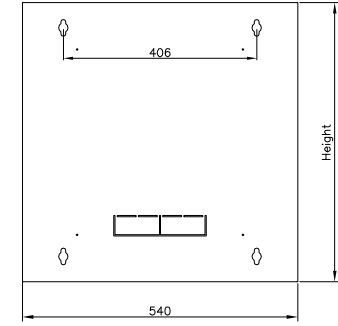

BACK

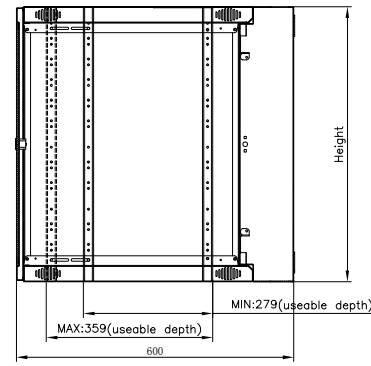

600 Deep Wall Cabinet

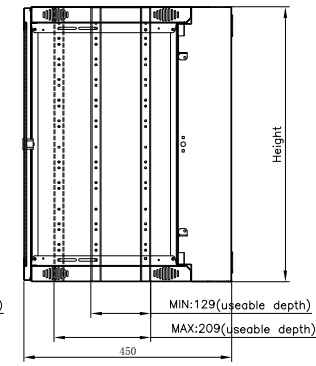

450 Deep Wall Cabinet

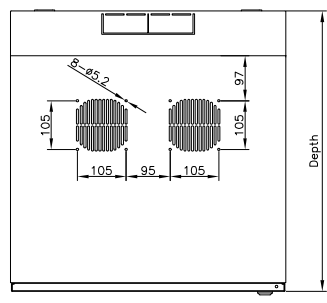

TOP

Material:
 SPCC Cold Rolled Steel;
 Thickness: 19" rails: 1.5mm, others:
 1.0mm
Loading Capacity:
 Static loading: 30KG

Compliance:
 Comply with ANSI/EIA
 RS-310-D、IEC60297-2、DIN41494;PART1;
 DIN41494;PART7

THESE DRAWINGS AND SPECIFICATIONS ARE THE PROPERTY OF INTRACOM Asia Co.,Ltd. AND SHALL NOT BE REPRODUCED COPIED OR USED IN ANY MANNER WITHOUT THE PRIOR WRITTEN CONSENT OF INTRACOM Asia Co.,Ltd.

UNLESS OTHERWISE SPECIFIED: DIMENSIONS ARE IN MILLIMETERS ANGULAR TOLERANCE: ±1°

TOLERANCE(INCH)		TOLERANCE(MM)	
x	±0.02"	x	±0.5mm
x.x	±0.01"	x.x	±0.20mm
x.xx	±0.008"	x.xx	±0.15mm
x.xxx	±0.005"	x.xxx	±0.10mm

Model No.	Capacity(U)	Width (mm)	Depth (mm)	Height (mm)	Colour
713740	6	540	450	327	Black
713757	6	540	450	327	Grey
713764	9	540	450	460	Black
713771	9	540	450	460	Grey
713788	12	540	450	593	Black
713795	12	540	450	593	Grey
713801	15	540	450	725	Black
713818	15	540	450	725	Grey
713825	6	540	600	327	Black
713832	6	540	600	327	Grey
713849	9	540	600	460	Black
713856	9	540	600	460	Grey
713863	12	540	600	593	Black
713870	12	540	600	593	Grey
713887	15	540	600	725	Black
713894	15	540	600	725	Grey

INTRACOM 安達康股份有限公司
 INTRACOM Asia Co.,LTD.

TITLE:	APPD	V-100843		
	Check			
CUSTOMER:	Drawer			Date
CUSTOMER P/N:		Unit	mm	Projection
ICT P/N:	Scale	1:1	Size.	A4
DWG.NO:	Sheet	1 of	REV.	A

1 2 3 4 5 6 7