

Galaxy VS

UPS with Internal Batteries

Technical Specifications

20-100 kW 480 V
10-50 kW 208 V

Latest updates are available on the Schneider Electric website
2/2023



Legal Information

The Schneider Electric brand and any trademarks of Schneider Electric SE and its subsidiaries referred to in this guide are the property of Schneider Electric SE or its subsidiaries. All other brands may be trademarks of their respective owners.

This guide and its content are protected under applicable copyright laws and furnished for informational use only. No part of this guide may be reproduced or transmitted in any form or by any means (electronic, mechanical, photocopying, recording, or otherwise), for any purpose, without the prior written permission of Schneider Electric.

Schneider Electric does not grant any right or license for commercial use of the guide or its content, except for a non-exclusive and personal license to consult it on an "as is" basis. Schneider Electric products and equipment should be installed, operated, serviced, and maintained only by qualified personnel.

As standards, specifications, and designs change from time to time, information contained in this guide may be subject to change without notice.

To the extent permitted by applicable law, no responsibility or liability is assumed by Schneider Electric and its subsidiaries for any errors or omissions in the informational content of this material or consequences arising out of or resulting from the use of the information contained herein.



**Find the manuals here:
Trouvez les manuels ici:**



https://www.productinfo.schneider-electric.com/galaxyvs_ul/

Table of Contents

| | |
|--|----|
| Important Safety Instructions — SAVE THESE INSTRUCTIONS | 7 |
| FCC Statement | 8 |
| Safety Precautions | 8 |
| ENERGY STAR Qualification..... | 9 |
| Model list | 10 |
| UPS with Internal Batteries Up to 2 Battery Strings..... | 14 |
| Single System Overview | 14 |
| Parallel System Overview | 15 |
| Input Voltage Window | 17 |
| Inverter Short Circuit Capabilities (Bypass not Available) | 19 |
| Efficiency | 22 |
| Derating Due to Load Power Factor | 23 |
| Batteries | 23 |
| End of Discharge Voltage | 23 |
| Battery Voltage Window | 24 |
| Battery Runtimes in Minutes | 24 |
| Compliance..... | 25 |
| Communication and Management | 26 |
| EPO..... | 26 |
| Configurable Input Contacts and Output Relays | 27 |
| Specifications..... | 28 |
| Recommended Cable Sizes for 200/208/220/480 V | 31 |
| Recommended Bolt and Lug Sizes..... | 32 |
| Torque Specifications | 32 |
| Environment..... | 33 |
| Heat Dissipation | 33 |
| UPS Shipping Weights and Dimensions | 34 |
| UPS Weights and Dimensions | 34 |
| Clearance | 34 |
| Drawings | 35 |
| 20 kW 480 V and 10 kW 208 V | 35 |
| Options..... | 36 |
| Configuration Options | 36 |
| Hardware Options..... | 37 |
| UPS with Internal Batteries Up to 4 Battery Strings..... | 38 |
| Single System Overview | 38 |
| Parallel System Overview | 39 |
| Input Voltage Window | 42 |
| Inverter Short Circuit Capabilities (Bypass not Available) | 44 |
| Efficiency | 47 |
| Derating Due to Load Power Factor | 49 |
| Batteries | 50 |
| End of Discharge Voltage | 50 |
| Battery Voltage Window | 50 |
| Battery Runtimes in Minutes | 51 |
| Compliance..... | 53 |

| | |
|--|------------|
| Communication and Management | 54 |
| EPO..... | 54 |
| Configurable Input Contacts and Output Relays | 55 |
| Specifications..... | 56 |
| Specifications for 480 V Systems | 56 |
| Specifications for 208 V Systems | 61 |
| Recommended Bolt and Lug Sizes..... | 66 |
| Torque Specifications | 66 |
| Environment..... | 67 |
| Heat Dissipation in BTU/hr..... | 67 |
| UPS Shipping Weights and Dimensions | 70 |
| UPS Weights and Dimensions | 70 |
| Clearance | 71 |
| Drawings | 72 |
| 10-50 kW 480 V and 10-25 kW 208 V UPS..... | 72 |
| Options..... | 73 |
| Configuration Options | 73 |
| Hardware Options..... | 74 |
| UPS with Internal Batteries Up to 5 Battery Strings..... | 76 |
| Single System Overview | 76 |
| Parallel System Overview | 77 |
| Input Voltage Window | 80 |
| Inverter Short Circuit Capabilities (Bypass not Available) | 82 |
| Efficiency | 85 |
| Derating Due to Load Power Factor | 89 |
| Batteries | 90 |
| End of Discharge Voltage | 90 |
| Battery Voltage Window | 90 |
| Battery Runtimes in Minutes | 91 |
| Compliance..... | 94 |
| Communication and Management | 95 |
| EPO..... | 95 |
| Configurable Input Contacts and Output Relays | 96 |
| Specifications..... | 97 |
| Specifications for 480 V Systems | 97 |
| Specifications for 208 V Systems | 103 |
| Torque Specifications | 109 |
| Environment..... | 110 |
| Heat Dissipation in BTU/hr..... | 110 |
| UPS Shipping Weights and Dimensions | 115 |
| UPS Weights and Dimensions | 116 |
| Clearance | 116 |
| Drawings | 117 |
| 20-50 kW (N+1 Power Module) and 60-100 kW 480 V UPS 10-25 kW (N+1 Power Module) and 30-50 kW 208 V UPS..... | 117 |
| Options..... | 118 |
| Configuration Options | 118 |
| Hardware Options..... | 119 |
| UPS with Input Isolation Transformer and Up to 3 Internal Battery Strings..... | 121 |

| | |
|---|------------|
| Single System Overview | 121 |
| Inverter Short Circuit Capabilities (Bypass not Available) | 121 |
| Efficiency | 123 |
| Derating Due to Load Power Factor | 124 |
| Batteries | 124 |
| End of Discharge Voltage | 124 |
| Battery Voltage Window | 124 |
| Battery Runtimes in Minutes | 125 |
| Compliance..... | 125 |
| Communication and Management | 125 |
| Configurable Input Contacts and Output Relays | 126 |
| Specifications..... | 128 |
| Specifications for 20 kW UPS with Input Isolation Transformer and Internal Batteries | 128 |
| Recommended Cable Sizes | 129 |
| Recommended Upstream Protection | 130 |
| Torque Specifications..... | 130 |
| Environment..... | 131 |
| UPS Shipping Weights and Dimensions | 132 |
| UPS Weights and Dimensions | 132 |
| Clearance | 132 |
| Drawings | 133 |
| 20 kW UPS with Input Isolation Transformer (480 V In 400 V Out)..... | 133 |
| Options..... | 134 |
| Configuration Options | 134 |
| Hardware Options..... | 134 |
| Weights and Dimensions for Options..... | 135 |
| Maintenance Bypass Cabinet Shipping Weights and Dimensions..... | 135 |
| Maintenance Bypass Cabinet Weights and Dimensions..... | 135 |
| Maintenance Bypass Cabinet with Transformer Shipping Weights and Dimensions | 135 |
| Maintenance Bypass Cabinet with Transformer Weights and Dimensions | 135 |
| Maintenance Bypass Panel Shipping Weights and Dimensions..... | 136 |
| Maintenance Bypass Panel Weights and Dimensions..... | 136 |
| Modular Battery Cabinet Shipping Weights and Dimensions | 136 |
| Modular Battery Cabinet Weights and Dimensions | 136 |
| Output Switch Box Shipping Weights and Dimensions..... | 136 |
| Output Switch Box Weights and Dimensions..... | 137 |
| Remote Alarm Panel Shipping Weights and Dimensions | 137 |
| Remote Alarm Panel Weights and Dimensions | 137 |
| Limited Factory Warranty..... | 138 |

Important Safety Instructions — SAVE THESE INSTRUCTIONS

Read these instructions carefully and look at the equipment to become familiar with it before trying to install, operate, service or maintain it. The following safety messages may appear throughout this manual or on the equipment to warn of potential hazards or to call attention to information that clarifies or simplifies a procedure.



The addition of this symbol to a “Danger” or “Warning” safety message indicates that an electrical hazard exists which will result in personal injury if the instructions are not followed.



This is the safety alert symbol. It is used to alert you to potential personal injury hazards. Obey all safety messages with this symbol to avoid possible injury or death.

DANGER

DANGER indicates a hazardous situation which, if not avoided, **will result in death or serious injury.**

Failure to follow these instructions will result in death or serious injury.

WARNING

WARNING indicates a hazardous situation which, if not avoided, **could result in death or serious injury.**

Failure to follow these instructions can result in death, serious injury, or equipment damage.

CAUTION

CAUTION indicates a hazardous situation which, if not avoided, **could result in minor or moderate injury.**

Failure to follow these instructions can result in injury or equipment damage.

NOTICE

NOTICE is used to address practices not related to physical injury. The safety alert symbol shall not be used with this type of safety message.

Failure to follow these instructions can result in equipment damage.

Please Note

Electrical equipment should only be installed, operated, serviced, and maintained by qualified personnel. No responsibility is assumed by Schneider Electric for any consequences arising out of the use of this material.

A qualified person is one who has skills and knowledge related to the construction, installation, and operation of electrical equipment and has received safety training to recognize and avoid the hazards involved.

FCC Statement

NOTE: This equipment has been tested and found to comply with the limits for a Class A digital device, pursuant to Part 15 of the FCC Rules. These limits are designed to provide reasonable protection against harmful interference when the equipment is operated in a commercial environment. This equipment generates, uses, and can radiate radio frequency energy and, if not installed and used in accordance with the instruction manual, may cause harmful interference to radio communications. Operation of this equipment in a residential area is likely to cause harmful interference in which case the user will be required to correct the interference at his own expense.

Any changes or modifications not expressly approved by the party responsible for compliance could void the user's authority to operate the equipment.

Safety Precautions

⚠ DANGER

HAZARD OF ELECTRIC SHOCK, EXPLOSION, OR ARC FLASH

- The product must be installed according to the specifications and requirements as defined by Schneider Electric. It concerns in particular the external and internal protections (upstream circuit breakers, battery circuit breakers, cabling, etc.) and environmental requirements. No responsibility is assumed by Schneider Electric if these requirements are not respected.
- After the UPS system has been electrically wired, do not start up the system. Start-up must only be performed by Schneider Electric.

Failure to follow these instructions will result in death or serious injury.

⚠ DANGER

HAZARD OF ELECTRIC SHOCK, EXPLOSION, OR ARC FLASH

The UPS System must be installed according to local and national regulations. Install the UPS according to:

- IEC 60364 (including 60364-4-41- protection against electric shock, 60364-4-42 - protection against thermal effect, and 60364-4-43 - protection against overcurrent), **or**
- NEC NFPA 70

depending on which one of the standards apply in your local area.

Failure to follow these instructions will result in death or serious injury.

⚠ DANGER

HAZARD OF ELECTRIC SHOCK, EXPLOSION, OR ARC FLASH

- Install the UPS system in a temperature controlled area free of conductive contaminants and humidity.
- Install the UPS system on a non-flammable, level, and solid surface (e.g. concrete) that can support the weight of the system.

Failure to follow these instructions will result in death or serious injury.

⚠ DANGER

HAZARD OF ELECTRIC SHOCK, EXPLOSION, OR ARC FLASH

The UPS is not designed for and must therefore not be installed in the following unusual operating environments:

- Damaging fumes
- Explosive mixtures of dust or gases, corrosive gases, or conductive or radiant heat from other sources
- Moisture, abrasive dust, steam or in an excessively damp environment
- Fungus, insects, vermin
- Salt-laden air or contaminated cooling refrigerant
- Pollution degree higher than 2 according to IEC 60664-1
- Exposure to abnormal vibrations, shocks, and tilting
- Exposure to direct sunlight, heat sources, or strong electromagnetic fields

Failure to follow these instructions will result in death or serious injury.

NOTICE

RISK OF OVERHEATING

Respect the clearance requirements around the UPS system and do not cover the product's ventilation openings when the UPS system is in operation.

Failure to follow these instructions can result in equipment damage.

NOTICE

RISK OF EQUIPMENT DAMAGE

Do not connect the UPS output to regenerative load systems including photovoltaic systems and speed drives.

Failure to follow these instructions can result in equipment damage.

ENERGY STAR Qualification



Select models are ENERGY STAR® qualified. For more information on your specific model go to www.se.com.

Model list

UPS with Internal Batteries Up to 2 Battery Strings



See UPS with Internal Batteries Up to 2 Battery Strings, page 14 for technical specifications for this UPS.

- Galaxy VS UPS 20 kW 480 V, with 1 internal 7 Ah smart modular battery string, expandable to 2, Start-up 5x8 (GVSUPS20KB2GS)
- Galaxy VS UPS 10 kW 208 V, with 1 internal 7 Ah smart modular battery string, expandable to 2, Start-up 5x8 (GVSUPS10KB2FS)

UPS with Internal Batteries Up to 4 Battery Strings



See UPS with Internal Batteries Up to 4 Battery Strings, page 38 for technical specifications for this UPS.

- Galaxy VS UPS 20 kW 480 V, with 1 internal 9 Ah smart modular battery string, expandable to 4, Start-up 5x8 (GVSUPS20KB4GS)
- Galaxy VS UPS 20 kW 480 V, for up to 4 internal 9 Ah smart modular battery strings, Start-up 5x8 (GVSUPS20K0B4GS)
- Galaxy VS UPS 30 kW 480 V, with 2 internal 9 Ah smart modular battery strings, expandable to 4, Start-up 5x8 (GVSUPS30KB4GS)
- Galaxy VS UPS 30 kW 480 V, for up to 4 internal 9 Ah smart modular battery strings, Start-up 5x8 (GVSUPS30K0B4GS)
- Galaxy VS UPS 40 kW 480 V, with 2 internal 9 Ah smart modular battery strings, expandable to 4, Start-up 5x8 (GVSUPS40KB4GS)
- Galaxy VS UPS 40 kW 480 V, for up to 4 internal 9 Ah smart modular battery strings, Start-up 5x8 (GVSUPS40K0B4GS)
- Galaxy VS UPS 50 kW 480 V, with 2 internal 9 Ah smart modular battery strings, expandable to 4, Start-up 5x8 (GVSUPS50KB4GS)
- Galaxy VS UPS 50 kW 480 V, for up to 4 internal 9 Ah smart modular battery strings, Start-up 5x8 (GVSUPS50K0B4GS)
- Galaxy VS UPS 10 kW 208 V, with 1 internal 9 Ah smart modular battery string, expandable to 4, Start-up 5x8 (GVSUPS10KB4FS)
- Galaxy VS UPS 10 kW 208 V, for up to 4 internal 9 Ah smart modular battery strings, Start-up 5x8 (GVSUPS10K0B4FS)
- Galaxy VS UPS 15 kW 208 V, with 2 internal 9 Ah smart modular battery strings, expandable to 4, Start-up 5x8 (GVSUPS15KB4FS)
- Galaxy VS UPS 15 kW 208 V, for up to 4 internal 9 Ah smart modular battery strings, Start-up 5x8 (GVSUPS15K0B4FS)
- Galaxy VS UPS 20 kW 208 V, with 2 internal 9 Ah smart modular battery strings, expandable to 4, Start-up 5x8 (GVSUPS20KB4FS)
- Galaxy VS UPS 20 kW 208 V, for up to 4 internal 9 Ah smart modular battery strings, Start-up 5x8 (GVSUPS20K0B4FS)
- Galaxy VS UPS 25 kW 208 V, with 2 internal 9 Ah smart modular battery strings, expandable to 4, Start-up 5x8 (GVSUPS25KB4FS)
- Galaxy VS UPS 25 kW 208 V, for up to 4 internal 9 Ah smart modular battery strings, Start-up 5x8 (GVSUPS25K0B4FS)

UPS with Internal Batteries Up to 5 Battery Strings



See UPS with Internal Batteries Up to 5 Battery Strings, page 76 for technical specifications for this UPS.

- Galaxy VS UPS 20 kW 480 V, with N+1 power module, for 5 smart modular 9 Ah battery strings, Start-up 5x8 (GVSUPS20KR0B5GS)
- Galaxy VS UPS 30 kW 480 V, with N+1 power module, for 5 smart modular 9 Ah battery strings, Start-up 5x8 (GVSUPS30KR0B5GS)
- Galaxy VS UPS 40 kW 480 V, with N+1 power module, for 5 smart modular 9 Ah battery strings, Start-up 5x8 (GVSUPS40KR0B5GS)
- Galaxy VS UPS 50 kW 480 V, with N+1 power module, for 5 smart modular 9 Ah battery strings, Start-up 5x8 (GVSUPS50KR0B5GS)
- Galaxy VS UPS 60 kW 480 V, with 3 internal 9 Ah smart modular battery strings, expandable to 5, Start-up 5x8 (GVSUPS60KB5GS)
- Galaxy VS UPS 60 kW 480 V, for up to 5 internal 9 Ah smart modular battery strings, Start-up 5x8 (GVSUPS60K0B5GS)
- Galaxy VS UPS 80 kW 480 V, with 3 internal 9 Ah smart modular battery strings, expandable to 5, Start-up 5x8 (GVSUPS80KB5GS)
- Galaxy VS UPS 80 kW 480 V, for up to 5 internal 9 Ah smart modular battery strings, Start-up 5x8 (GVSUPS80K0B5GS)
- Galaxy VS UPS 100 kW 480 V, with 3 internal 9 Ah smart modular battery strings, expandable to 5, Start-up 5x8 (GVSUPS100KB5GS)
- Galaxy VS UPS 100 kW 480 V, for up to 5 internal 9 Ah smart modular battery strings, Start-up 5x8 (GVSUPS100K0B5GS)
- Galaxy VS UPS 10 kW 208 V, with N+1 power module, for 5 smart modular 9 Ah battery strings, Start-up 5x8 (GVSUPS10KR0B5FS)
- Galaxy VS UPS 15 kW 208 V, with N+1 power module, for 5 smart modular 9 Ah battery strings, Start-up 5x8 (GVSUPS15KR0B5FS)
- Galaxy VS UPS 20 kW 208 V, with N+1 power module, for 5 smart modular 9 Ah battery strings, Start-up 5x8 (GVSUPS20KR0B5FS)
- Galaxy VS UPS 25 kW 208 V, with N+1 power module, for 5 smart modular 9 Ah battery strings, Start-up 5x8 (GVSUPS25KR0B5FS)
- Galaxy VS UPS 30 kW 208 V, with 3 internal 9 Ah smart modular battery strings, expandable to 5, Start-up 5x8 (GVSUPS30KB5FS)
- Galaxy VS UPS 30 kW 208 V, for up to 5 internal 9 Ah smart modular battery strings, Start-up 5x8 (GVSUPS30K0B5FS)
- Galaxy VS UPS 40 kW 208 V, with 3 internal 9 Ah smart modular battery strings, expandable to 5, Start-up 5x8 (GVSUPS40KB5FS)
- Galaxy VS UPS 40 kW 208 V, for up to 5 internal 9 Ah smart modular battery strings, Start-up 5x8 (GVSUPS40K0B5FS)
- Galaxy VS UPS 50 kW 208 V, with 3 internal 9 Ah smart modular battery strings, expandable to 5, Start-up 5x8 (GVSUPS50KB5FS)
- Galaxy VS UPS 50 kW 208 V, for up to 5 internal 9 Ah smart modular battery strings, Start-up 5x8 (GVSUPS50K0B5FS)

UPS with Input Isolation Transformer and Up to 3 Internal Battery Strings



See UPS with Input Isolation Transformer and Up to 3 Internal Battery Strings, page 121 for technical specifications for this UPS.

- Galaxy VS UPS 20kW with transformer, 480V Input 400V Output, with 2 modular battery strings expandable to 3 (GVSUPS20K100B3H)

UPS with Internal Batteries Up to 2 Battery Strings

Single System Overview

| | |
|------|---|
| UIB | Unit input breaker |
| SSIB | Static switch input breaker |
| IMB | Internal maintenance breaker |
| UOB | Unit output breaker |
| BB | Battery breaker in UPS for internal batteries |

Single System – Single Mains

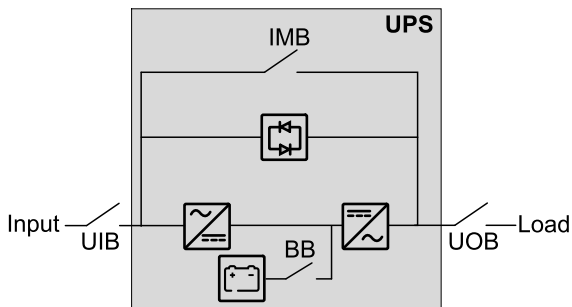

Single System – Dual Mains

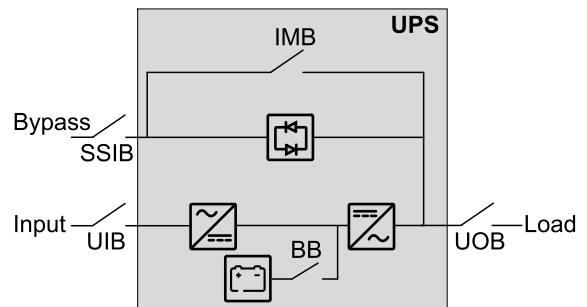

Parallel System Overview

| | |
|------|---|
| UIB | Unit input breaker |
| SSIB | Static switch input breaker |
| IMB | Internal maintenance breaker |
| UOB | Unit output breaker |
| SIB | System isolation breaker |
| BB | Battery breaker in UPS for internal batteries |
| MBB | External maintenance bypass breaker |

Parallel Systems with Individual Unit Input Breaker UIB and Static Switch Input Breaker SSIB

Galaxy VS can support up to 4 UPSs in parallel for capacity and up to 3+1 UPSs in parallel for redundancy with individual unit input breaker UIB and static switch input breaker SSIB.

NOTE: In parallel systems an external maintenance bypass breaker MBB must be provided and the internal maintenance breaker IMB* must be padlocked in the open position.

Parallel System – Single Mains

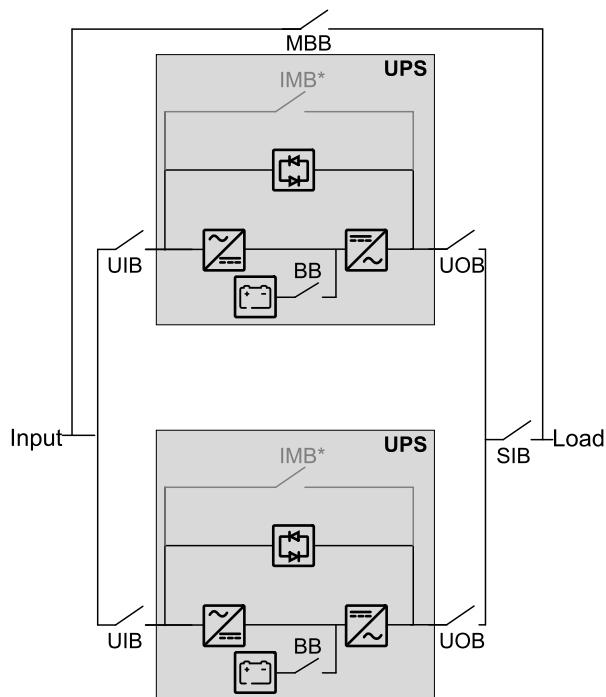

Parallel System – Dual Mains

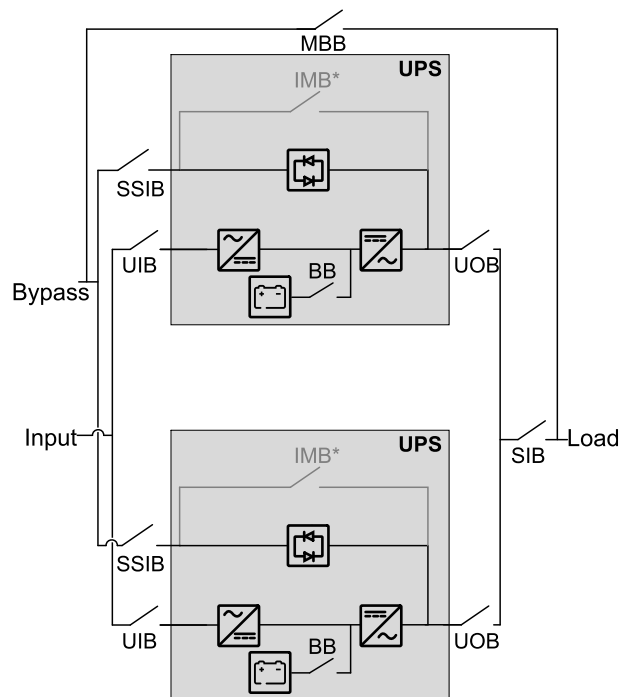

Parallel Systems with Shared Unit Input Breaker UIB and Static Switch Input Breaker SSIB

Galaxy VS can support up to 4 UPSs in parallel for capacity and up to 3+1 UPSs in parallel for redundancy with shared unit input breaker UIB and static switch input breaker SSIB.

NOTE: In parallel systems an external maintenance bypass breaker MBB must be provided and the internal maintenance breaker IMB* must be padlocked in the open position.

Parallel System – Single Mains

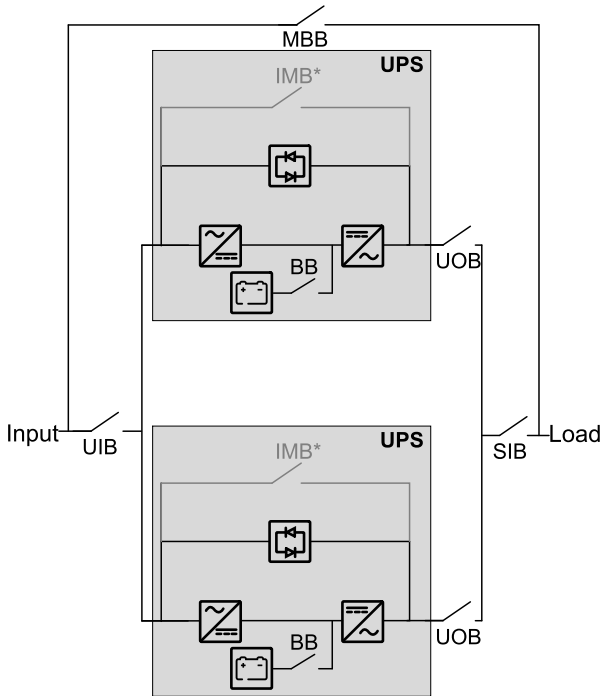

Parallel System – Dual Mains

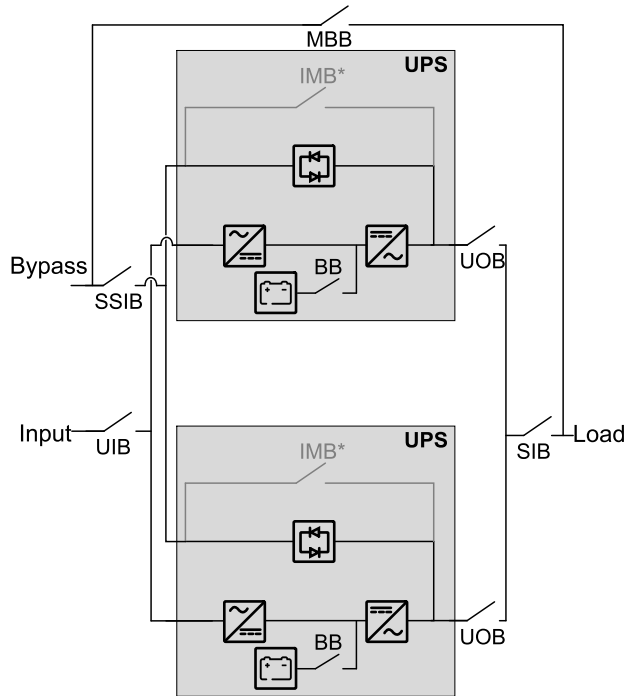

Input Voltage Window

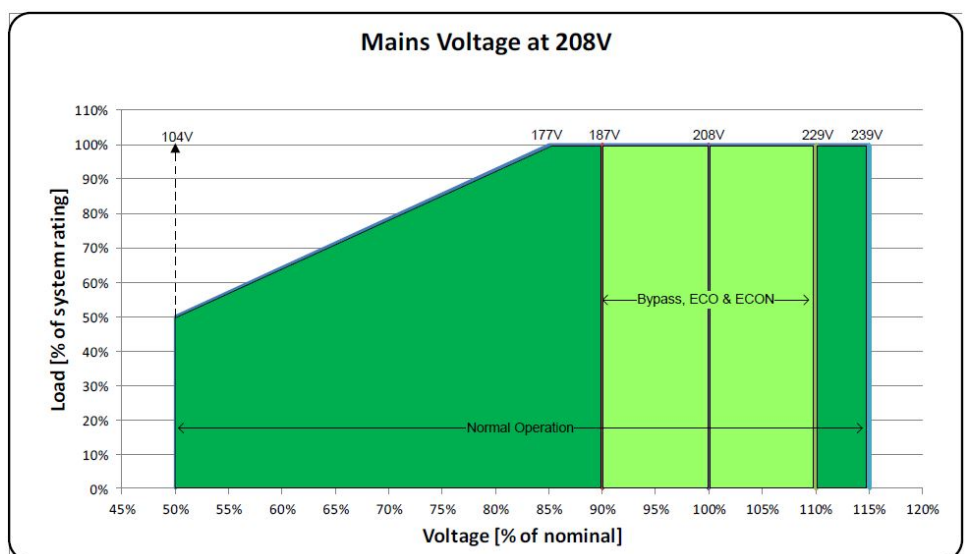
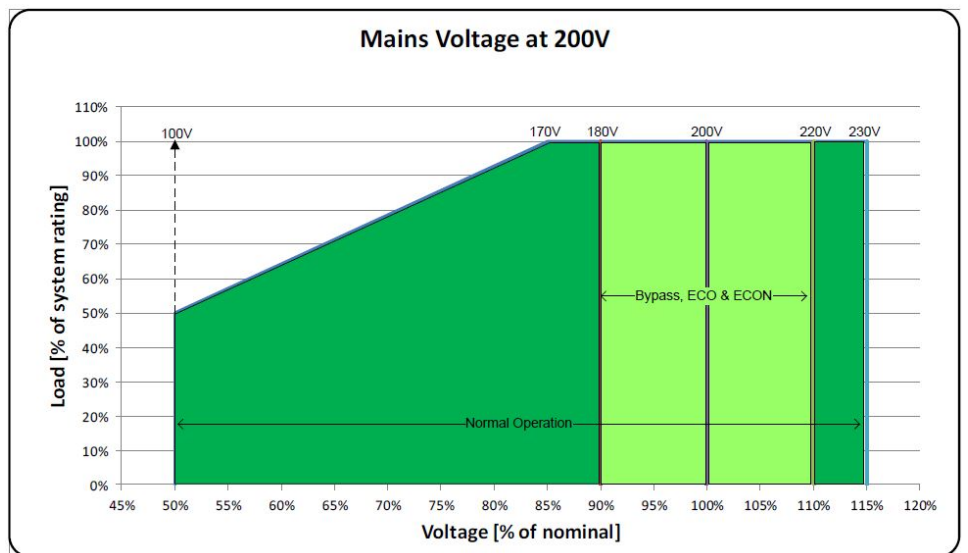
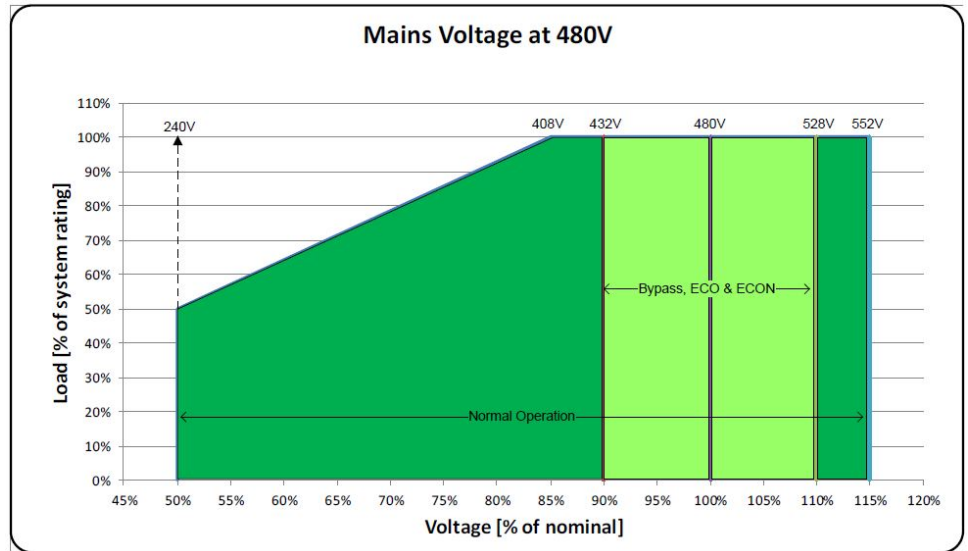

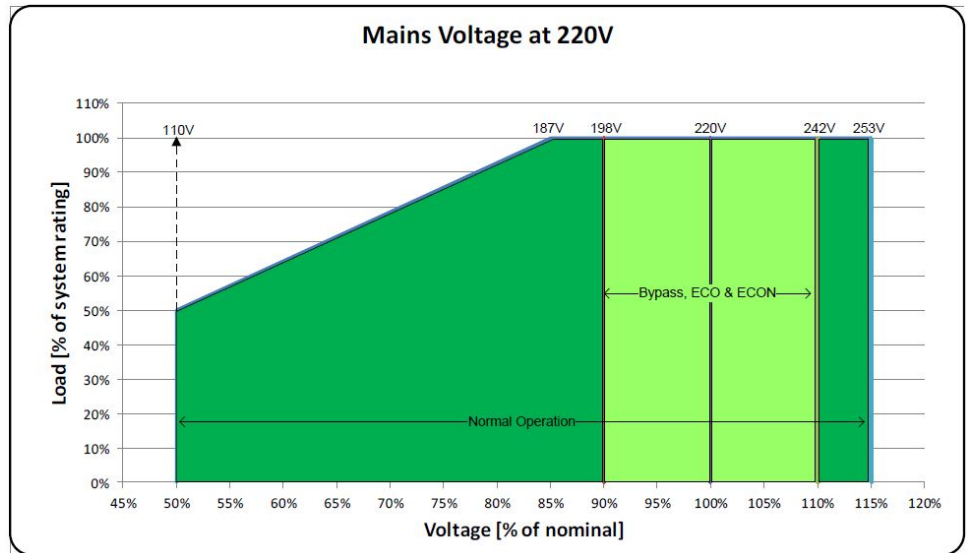

Inverter Short Circuit Capabilities (Bypass not Available)

IK1 – Short Circuit between a Phase and Neutral

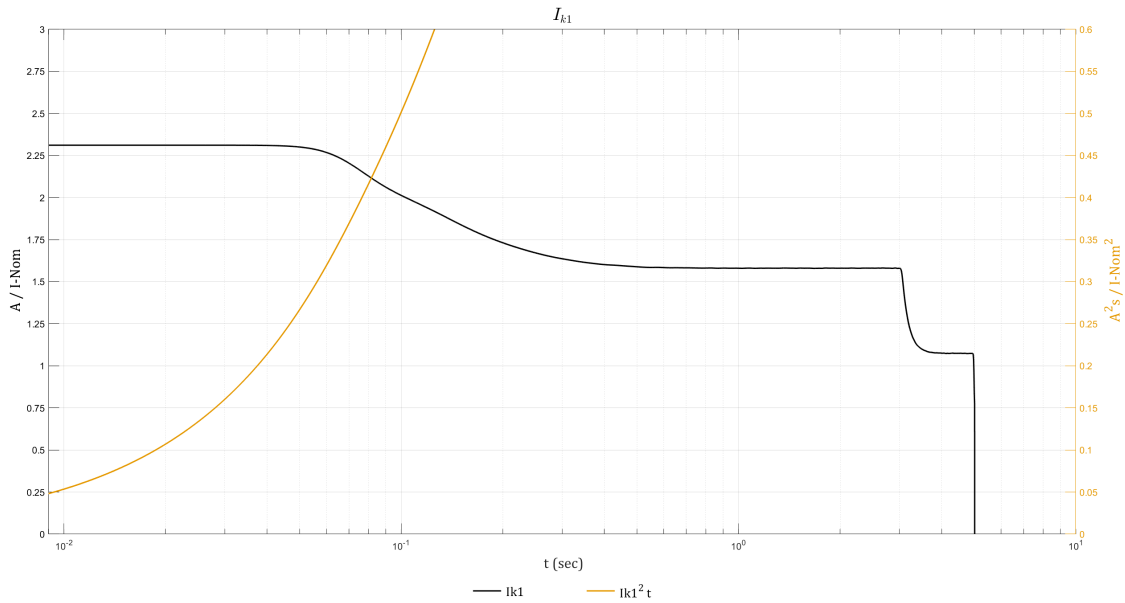

IK1 480 V

| S [kVA] | 10ms; I[A]/I ² t [A ² t] | 20ms; I[A]/I ² t [A ² t] | 30ms; I[A]/I ² t [A ² t] | 100ms; I[A]/I ² t [A ² t] | 1s; I[A]/I ² t [A ² t] |
|---------|--|--|--|---|--|
| 20 | 56 / 31 | 56 / 62 | 56 / 93 | 48 / 290 | 38 / 1674 |

IK1 208 V

| S [kVA] | 10ms; I[A]/I ² t [A ² t] | 20ms; I[A]/I ² t [A ² t] | 30ms; I[A]/I ² t [A ² t] | 100ms; I[A]/I ² t [A ² t] | 1s; I[A]/I ² t [A ² t] |
|---------|--|--|--|---|--|
| 10 | 64 / 41 | 64 / 82 | 64 / 123 | 56 / 386 | 44 / 2229 |

IK2 – Short Circuit between Two Phases

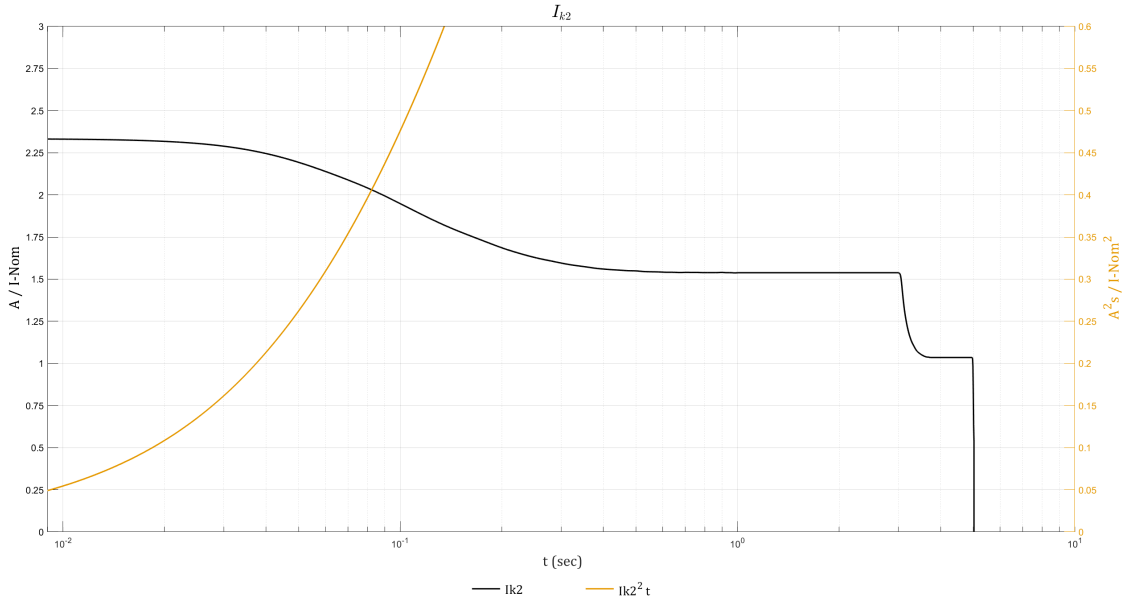

IK2 480 V

| S [kVA] | 10ms; I[A]/I ² t [A ² t] | 20ms; I[A]/I ² t [A ² t] | 30ms; I[A]/I ² t [A ² t] | 100ms; I[A]/I ² t [A ² t] | 1s; I[A]/I ² t [A ² t] |
|---------|--|--|--|---|--|
| 20 | 56 / 31 | 56 / 63 | 56 / 94 | 47 / 276 | 37 / 1586 |

IK2 208 V

| S [kVA] | 10ms; I[A]/I ² t [A ² t] | 20ms; I[A]/I ² t [A ² t] | 30ms; I[A]/I ² t [A ² t] | 100ms; I[A]/I ² t [A ² t] | 1s; I[A]/I ² t [A ² t] |
|---------|--|--|--|---|--|
| 10 | 65 / 42 | 64 / 84 | 64 / 125 | 54 / 367 | 43 / 2112 |

IK3 – Short Circuit between Three Phases

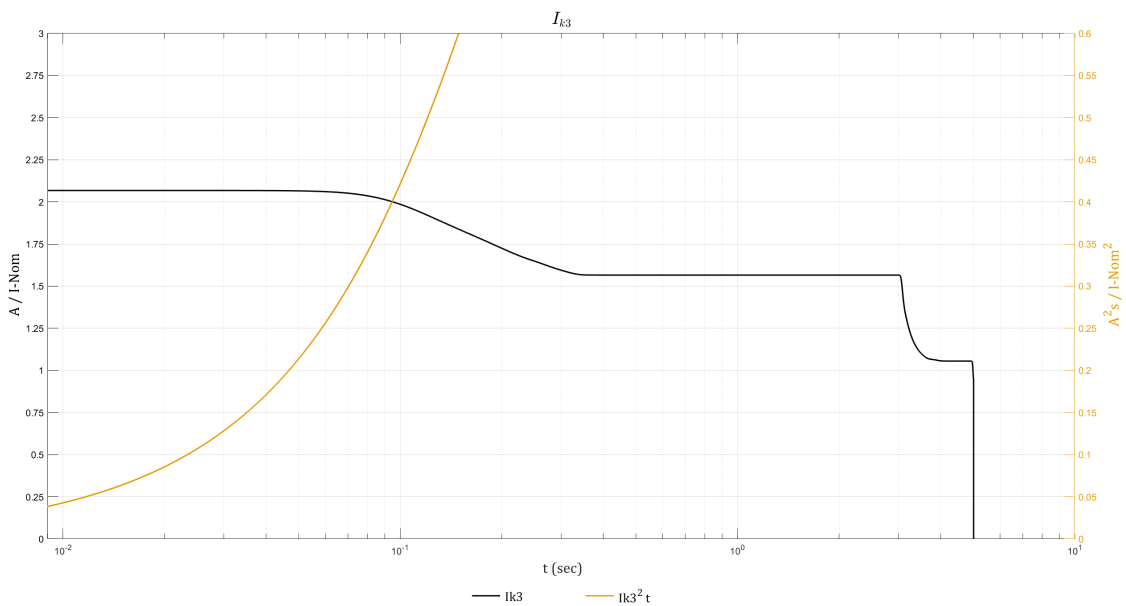

IK3 480 V

| S [kVA] | 10ms; I[A]/I ² t [A ² t] | 20ms; I[A]/I ² t [A ² t] | 30ms; I[A]/I ² t [A ² t] | 100ms; I[A]/I ² t [A ² t] | 1s; I[A]/I ² t [A ² t] |
|---------|--|--|--|---|--|
| 20 | 50 / 25 | 50 / 49 | 50 / 74 | 48 / 244 | 38 / 1593 |

IK3 208 V

| S [kVA] | 10ms; I[A]/I ² t [A ² t] | 20ms; I[A]/I ² t [A ² t] | 30ms; I[A]/I ² t [A ² t] | 100ms; I[A]/I ² t [A ² t] | 1s; I[A]/I ² t [A ² t] |
|---------|--|--|--|---|--|
| 10 | 57 / 33 | 57 / 66 | 57 / 99 | 55 / 325 | 43 / 2121 |

Efficiency

480 V UPS

| 20 kW UPS | Normal operation | ECO mode | eConversion | Battery operation |
|-----------|------------------|----------|-------------|-------------------|
| 25% load | 94.8% | 97.0% | 96.7% | 94.4% |
| 50% load | 96.3% | 98.3% | 98.1% | 96.2% |
| 75% load | 96.8% | 98.7% | 98.6% | 96.4% |
| 100% load | 96.8% | 98.9% | 98.8% | 96.3% |

208 V UPS

| 10 kW UPS | Normal operation | | | ECO mode | | |
|-------------|------------------|-------|-------|----------|-------|-------|
| Voltage (V) | 200 | 208 | 220 | 200 | 208 | 220 |
| 25% load | 92.1% | 93.3% | 92.4% | 94.7% | 94.8% | 94.8% |
| 50% load | 93.8% | 94.6% | 94.2% | 96.9% | 96.9% | 96.9% |
| 75% load | 93.8% | 94.7% | 94.4% | 97.5% | 97.5% | 97.6% |
| 100% load | 93.2% | 94.4% | 94.1% | 97.7% | 97.8% | 97.9% |

| 10 kW UPS | eConversion | | | Battery operation | | |
|-------------|-------------|-------|-------|-------------------|-------|-------|
| Voltage (V) | 200 | 208 | 220 | 200 | 208 | 220 |
| 25% load | 94.7% | 94.9% | 94.9% | 89.2% | 90.4% | 89.5% |
| 50% load | 96.8% | 96.9% | 96.9% | 93.2% | 93.6% | 93.5% |
| 75% load | 97.5% | 97.6% | 97.6% | 94.1% | 94.4% | 94.5% |
| 100% load | 97.7% | 97.8% | 97.9% | 94.3% | 94.6% | 94.8% |

Derating Due to Load Power Factor

0.7 leading to 0.7 lagging without derating.

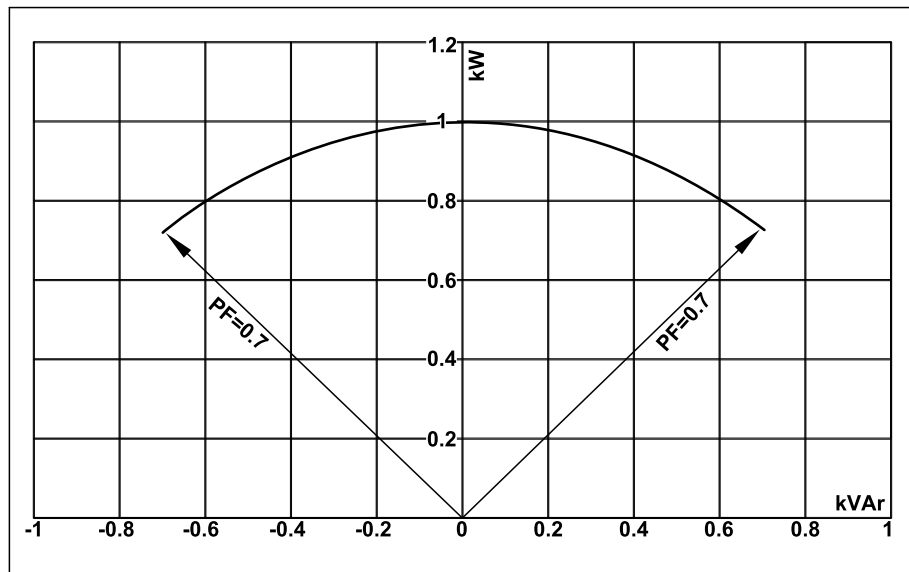

| UPS rating | UPS output | | | | | |
|------------|----------------|----------------|----------------|----------------|----------------|----------------|
| | Lagging | | | Leading | | |
| PF=1 | PF=0.7 | PF=0.8 | PF=0.9 | PF=0.9 | PF=0.8 | PF=0.7 |
| 10 kVA/kW | 10 kVA / 7 kW | 10 kVA / 8 kW | 10 kVA / 9 kW | 10 kVA / 9 kW | 10 kVA / 8 kW | 10 kVA / 7 kW |
| 20 kVA/kW | 20 kVA / 14 kW | 20 kVA / 16 kW | 20 kVA / 18 kW | 20 kVA / 18 kW | 20 kVA / 16 kW | 20 kVA / 14 kW |

Batteries

End of Discharge Voltage

The voltage is 1.6 to 1.75 per cell depending on discharge ratio.

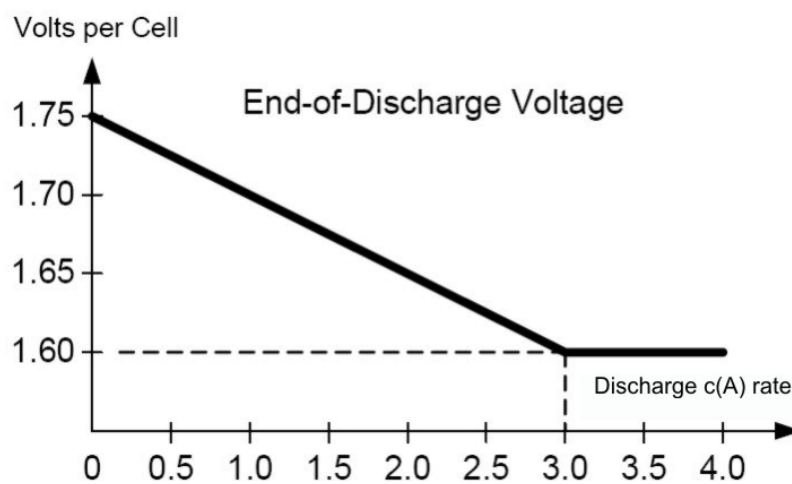

Battery Voltage Window

| | Boost 2.38 Vpc | Nominal 2.0 Vpc | Minimum 1.6 Vpc |
|---------------------|-----------------------|------------------------|------------------------|
| Battery voltage (V) | 571.2 | 480 | 384 |

Battery Runtimes in Minutes

480 V UPS

| | |
|--|--------------|
| UPS rating | 20 kW |
| Number of modular battery strings | |
| 1 | NA |
| 2 | 8.4 |

208 V UPS

| | |
|--|--------------|
| UPS rating | 10 kW |
| Number of modular battery strings | |
| 1 | 8.3 |
| 2 | 22 |

Compliance

| | |
|----------------|---|
| Safety | IEC 62040-1: 2008-06, 1st edition Uninterruptible Power Systems (UPS) - Part 1: General and safety requirements for UPS IEC 62040-1: 2013-01, 1st edition amendment 1 UL 1778 5th edition |
| EMC/EMI/RFI | IEC 62040-2: 2016, 3rd edition Uninterruptible Power Systems (UPS) - Part 2: Electromagnetic compatibility (EMC) requirements C2 FCC Part 15 Subpart B, Class A IEEE C62.41-1991 Location Category B2, IEEE Recommended Practice on Surge Voltages in Low-Voltage AC Power Circuits |
| Transportation | IEC 60721-4-2 Level 2M1 |
| Seismic | ICC-ES AC 156 (2015): OHSPD Pre-approved; Sds=1.33 g for z/h=1 and Sds=1.63 g for z/h=0; Ip= 1.5 |

Performance

Performance in accordance with: IEC 62040-3: 2021, 3rd edition Uninterruptible Power Systems (UPS) - Part 3: Method of specifying the performance and test requirements.

Regional Seismic Compliance

Certificate available upon request.

| Country/Region | Code ID | Hazard level ground | Hazard level roof |
|---------------------|---------------------------------|-----------------------------------|-----------------------------------|
| Argentina | INPRES-CIRSOC103 | Zone 4 | Zone 4 |
| Australia | AS 1170.4-2007 | Z = 0.22 | Z = 0.22 |
| Canada ¹ | 2020 NBCC | S _a = 2.0 | S _a = 1.46 |
| Chile | NCh 433.Of1996 | Zone 3 | Zone 2 |
| China | GB 50011-2010 (2016) | $\alpha_{Max} = 1.4$ | $\alpha_{Max} = 1.2$ |
| Europe | Eurocode 8 EN1998-1 | $\alpha_{gR} = 0.45$ | $\alpha_{gR} = 0.3$ |
| India | IS 1893 (Part 1) : 2016 | Z = 0.36 | Z = 0.36 |
| Japan | Building Standard Law | Zone A | Zone A |
| New Zealand | NZS 1170.5:2004+A1 | Z = 0.6 | Z = 0.42 |
| Peru | N.T.E. - E.030 | Zone 4 | Zone 4 |
| Russia | SNIP II-7-81 (SP 14.13330.2014) | MSK 10 | MSK 9 |
| Taiwan | CPA 2011 Seismic Design Code | S _s ^D = 0.8 | S _s ^D = 0.8 |
| U.S.A. ¹ | ASCE 7-16 / IBC 2018 | S _{DS} = 2.0 | S _{DS} = 1.47 |

1. OSHPD Pre-approved in accordance with AC156 test protocol.

Communication and Management

| | |
|---------------------------|---|
| Local area network | 1 Gbps – 1 port as default |
| Modbus | Modbus (SCADA) |
| Output relays | 4 x SELV configurable |
| Input contacts | 4 x SELV configurable |
| Standard control panel | 4.3 inch touchscreen display |
| Audible alarm | Yes |
| Emergency Power Off (EPO) | Options: <ul style="list-style-type: none"> • Normally Open (NO) • Normally Closed (NC) • External 24 VDC SELV |
| External switchgear | UIB UOB SSIB MBB SIB |
| External synchronization | No |
| Battery monitoring | Available for modular batteries |

EPO

EPO Configurations (640–4864 terminal J6600, 1–9)

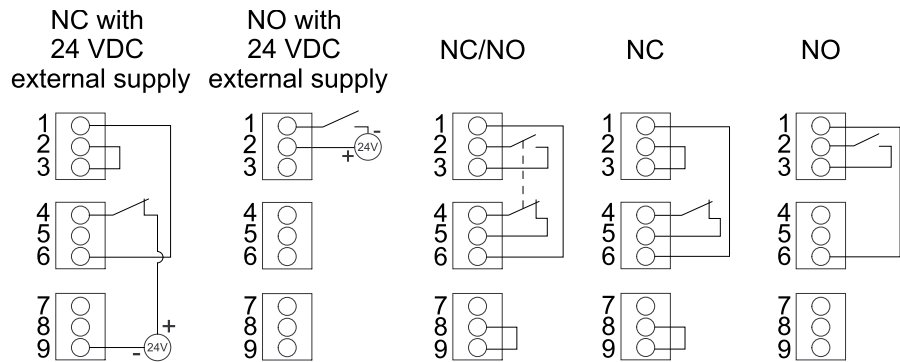

The EPO input supports 24 VDC.

NOTE: The default setting for the EPO activation is to turn off the inverter.

If you want the EPO activation to transfer the UPS into forced static bypass operation instead, please contact Schneider Electric.

Configurable Input Contacts and Output Relays

Input Contacts

Four input contacts are available and can be configured to indicate a given event via the display. The input contacts support 24 VDC 10 mA.

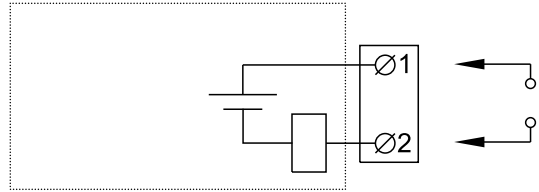

| Name | Description | Location |
|-------------------------|----------------------------|------------------------------|
| IN _1 (input contact 1) | Configurable input contact | 640-4864 terminal J6616, 1–2 |
| IN _2 (input contact 2) | Configurable input contact | 640-4864 terminal J6616, 3–4 |
| IN _3 (input contact 3) | Configurable input contact | 640-4864 terminal J6616, 5–6 |
| IN _4 (input contact 4) | Configurable input contact | 640-4864 terminal J6616, 7–8 |

Output Relays

Four output relays are available and can be configured to activate on one or more events via the display.

The output relays support 24 VAC/VDC 1 A. All external circuitry must be fused with maximum 1 A fast acting fuses.

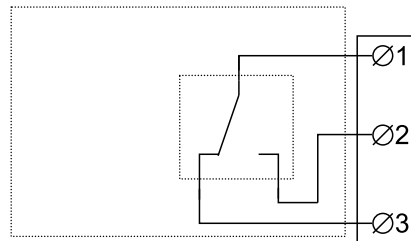

| Name | Description | Location |
|-------------------------|---------------------------|--------------------------------|
| OUT _1 (output relay 1) | Configurable output relay | 640–4864 terminal J6617, 1–3 |
| OUT _2 (output relay 2) | Configurable output relay | 640–4864 terminal J6617, 4–6 |
| OUT _3 (output relay 3) | Configurable output relay | 640–4864 terminal J6617, 7–9 |
| OUT _4 (output relay 4) | Configurable output relay | 640–4864 terminal J6617, 10–12 |

Energized check mode: When this mode is enabled, it means that the output relay is activated when the events associated with the output relay are not present (normally activated). **Energized check mode** is individually set for each output relay and makes it possible to detect if the power supply to the output relays is lost, as all output relays will deactivate and the events associated with the output relays will be indicated as present.

Specifications

Input Specifications

| UPS rating | 10 kW | 20 kW |
|----------------------------------|---|--|
| Voltage (V) | 200/208/220 | 480 |
| Connections | 4-wire (L1, L2, L3, N, G) WYE (single mains) 3-wire (L1, L2, L3, G) WYE (dual mains) | 3-wire (L1, L2, L3, G) WYE or 4-wire (L1, L2, L3, N, G) WYE (single mains) 3-wire (L1, L2, L3, G) WYE (dual mains) ² |
| Input voltage range (V) | 200 V: 170-230 208 V: 177-239 220 V: 187-253 | 408-552 |
| Frequency range (Hz) | 40-70 | |
| Nominal input current (A) | 31/30/28 | 25 |
| Maximum input current (A) | 37/36/34 | 30 |
| Input current limitation (A) | 39/37/35 | 31 |
| Input power factor | 0.99 for load greater than 50% 0.95 for load greater than 25% | |
| Total harmonic distortion (THDI) | <3% at full linear load (symmetrical) | |
| Maximum short circuit rating | 65 kA RMS | |
| Protection | Built-in backfeed protection and fuses | |
| Ramp-in | Programmable and adaptive 1-40 seconds | |

Bypass Specifications

| UPS rating | 10 kW | 20 kW |
|---|---|--|
| Voltage (V) | 200/208/220 | 480 |
| Connections | 4-wire (L1, L2, L3, N, G) WYE | 3-wire (L1, L2, L3, G) WYE or 4-wire (L1, L2, L3, N, G) WYE ² |
| Bypass voltage range (V) | 200 V: 180-220 208 V: 187-229 220 V: 198-242 | 432-528 |
| Frequency range (Hz) | 50/60 ± 1, 50/60 ± 3, 50/60 ± 10 (user selectable) | |
| Nominal bypass current (A) | 29/28/27 | 24 |
| Nominal neutral current (A) | 50/48/45 | 42 |
| Maximum short circuit rating ³ | 65 kA RMS | |
| Protection | Built-in backfeed protection and fuses Internal fuse specifications: Rated 160 A, prearcing 2.68 kA ² s | |

2. TN and TT power distribution systems are supported. Corner (line) grounding is not supported.

3. Conditioned by the internal fuse rated 160 A, prearcing 2.68 kA²s.

Output Specifications

NOTE: The number of output connections must match the number of input wires in a single mains system or bypass wires in a dual mains system.

| UPS rating | 10 kW | 20 kW |
|----------------------------------|---|--|
| Voltage (V) | 200/208/220 | 480 |
| Connections | 4-wire (L1, L2, L3, N, G) | 3-wire (L1, L2, L3, G, GEC ⁴) or 4-wire (L1, L2, L3, N, G) |
| Output voltage regulation | Symmetrical load ± 1% Asymmetrical load ± 3% | |
| Overload capacity | 150% for 1 minute (in normal operation) 125% for 10 minutes (in normal operation) 125% for 1 minute (in battery operation) 125% continuous (bypass operation) 1000% for 100 milliseconds (bypass operation) | |
| Dynamic load response | ± 5% after 2 milliseconds ± 1% after 50 milliseconds | |
| Output power factor | 1 | |
| Nominal output current (A) | 29/28/26 | 24 |
| Frequency regulation (Hz) | 50/60 Hz bypass synchronized – 50/60 Hz ± 0.1% free-running | |
| Synchronized slew rate (Hz/sec) | Programmable to 0.25, 0.5, 1, 2, 4, 6 | |
| Total harmonic distortion (THDU) | <2% for linear load <5% for non-linear load | <1% for linear load <3% for non-linear load |
| Load crest factor | 2.5 | |
| Load power factor | From 0.7 leading to 0.7 lagging without any derating | |

Battery Specifications

All values are based on 40 battery blocks.

| UPS rating | 10 kW | 20 kW |
|--|--|-------|
| Voltage (V) | 200/208/220 | 480 |
| Charging power in % of output power at 0-40% load | 80% | |
| Charging power in % of output power at 100% load | 20% | |
| Maximum charging power (at 0-40% load) (kW) | 8 | 16 |
| Maximum charging power (at 100% load) (kW) | 2 | 4 |
| Nominal battery voltage (VDC) | 480 | |
| Nominal float voltage (VDC) | 545 | |
| Maximum boost voltage (VDC) | 571 | |
| Temperature compensation (per cell) | -3.3mV/°C, for T ≥ 25 °C – 0mV/°C, for T < 25 °C | |
| End of discharge voltage (full load) (VDC) | 384 | |
| Battery current at full load and nominal battery voltage (A) | 22 | 43 |
| Battery current at full load and minimum battery voltage (A) | 27 | 54 |
| Ripple current | < 5% C20 (5 minute runtime) | |

4. Per NEC 250.30.

| | | |
|------------------------------|-------------------------------|--------------|
| UPS rating | 10 kW | 20 kW |
| Voltage (V) | 200/208/220 | 480 |
| Battery test | Manual/automatic (selectable) | |
| Maximum short circuit rating | 10 kA | |

Recommended Upstream Protection

| |
|--|
| ⚠ CAUTION |
| <p>HAZARD OF FIRE</p> <ul style="list-style-type: none"> • Connect only to a circuit with the below specifications. • Connect to a circuit provided with a 63 A branch circuit overcurrent protection maximum in accordance with the National Electrical Code, ANSI/NFPA70, and the Canadian Electrical Code, Part I, C22.1. <p>Failure to follow these instructions can result in injury or equipment damage.</p> |

NOTE: Overcurrent protection is to be provided by others and marked with its function.

| | | | | |
|--|--------------------|---------------|--------------|---------------|
| UPS rating | 10 kW | | 20 kW | |
| Voltage (V) | 200/208/220 | | 480 | |
| | Input | Bypass | Input | Bypass |
| Breaker type | HJF36100U31X | | HJF36100U31X | |
| I _r setting | 50 | 40 | 40 | 35 |
| Tr at 6 I _r setting | 0.5 | | 0.5 | |
| I _i (x I _n) setting | 1.5 | | 1.5 | |

Recommended Cable Sizes for 200/208/220/480 V

⚡⚠ DANGER

HAZARD OF ELECTRIC SHOCK, EXPLOSION, OR ARC FLASH

All wiring must comply with all applicable national and/or electrical codes. The maximum allowable cable size is 4 AWG.

Failure to follow these instructions will result in death or serious injury.

NOTE: Overcurrent protection is to be provided by others.

Cable sizes in this manual are based on Table 310.15 (B)(16) of the National Electrical Code (NEC) with the following assertions:

- 90 °C (194 °F) conductors (75 °C (167 °F) termination)
- An ambient temperature of 30 °C (86 °F)
- Use of copper conductors

If the ambient temperature is greater than 30 °C (86 °F), larger conductors are to be selected in accordance with the correction factors of the NEC.

Equipment grounding conductors (EGC) are sized in accordance with NEC Article 250.122 and Table 250.122.

NOTE: Recommended cable sizes and maximum allowable cable size may vary for the auxiliary products. Not all auxiliary products support aluminum cables. Refer to the installation manual provided with the auxiliary product.

NOTE: Neutral conductor is sized to handle 1.73 times phase current in case of high harmonic content from non-linear loads. If non or less harmonic currents are expected, neutral conductor can be sized accordingly but not less than the phase conductor.

Copper

| UPS rating | 10 kW | 20 kW |
|-----------------------------------|-------------|-------|
| Voltage (V) | 200/208/220 | 480 |
| Input phases (AWG/kcmil) | 8 | 8 |
| Input EGC (AWG/kcmil) | 8 | 10 |
| Bypass/output phases (AWG/kcmil) | 8 | 10 |
| Bypass EGC/output EGC (AWG/kcmil) | 8 | 10 |
| Neutral (AWG/kcmil) | 6 | 6 |

NOTE: Cable sizes are based on 80% rated circuit breakers for UIB, UOB, MBB, SSIB.

Recommended Bolt and Lug Sizes

NOTICE

RISK OF EQUIPMENT DAMAGE

Use only UL approved compression cable lugs.

Failure to follow these instructions can result in equipment damage.

Narrow One Hole Lugs for Equipment Grounding Conductor/PE Cables

| Cable size | Bolt size | Cable lug type | Crimping tool | Die |
|------------|------------|----------------|---------------|-------------------|
| 10 AWG | M6 x 16 mm | LCA10-14-L | CT-1570 | NA |
| 8 AWG | M6 x 16 mm | LCA8-14-L | CT-720 | CD-720-1 Red P21 |
| 6 AWG | M6 x 16 mm | LCA6-14-L | CT-720 | CD-720-1 Blue P24 |
| 4 AWG | M6 x 16 mm | LCA4-14-L | CT-720 | CD-720-1 Gray P29 |

Narrow Insulated Ferrule for Phase Cables and N Cables

| Bolt size | Insulated ferrule type | Crimping tool |
|-----------|------------------------|------------------------------------|
| 10 AWG | FSD82-18-C | CT-1002, CT-1003, CT-1123 |
| 8 AWG | FSD83-18-C | CT-1003, CT-1004, CT-1104, CT-1123 |
| 6 AWG | FSD84-18-C | CT-1003, CT-1004, CT-1104 |
| 4 AWG | FSD85-18-L | CT-1005 |

Torque Specifications

| Bolt size | Torque |
|-----------|-------------------------------------|
| M4 | 1.7 Nm (1.25 lb-ft / 15 lb-in) |
| M5 | 2.2 Nm (1.62 lb-ft / 19.5 lb-in) |
| M6 | 5 Nm (3.69 lb-ft / 44.3 lb-in) |
| M8 | 17.5 Nm (12.91 lb-ft / 154.9 lb-in) |
| M10 | 30 Nm (22 lb-ft / 194.7 lb-in) |
| M12 | 50 Nm (36.87 lb-ft / 442.5 lb-in) |

Environment

| | Operating | Storage |
|--|---|--|
| Temperature | 0 °C to 40 °C (32 °F to 104 °F) | -15 °C to 40 °C (5 °F to 104 °F) for systems with batteries. |
| Relative humidity | 0 - 95% non-condensing | 10 - 80% non-condensing |
| Elevation | Designed for operation in 0-3000 m (0-10000 feet) elevation. Power derating required from 1000-3000 m (3300-10000 feet): Up to 1000 m (3300 feet): 1.000 Up to 1500 m (5000 feet): 0.975 Up to 2000 m (6600 feet): 0.950 Up to 2500 m (8300 feet): 0.925 Up to 3000 m (10000 feet): 0.900 | |
| Audible noise one meter (three feet) from unit | 480 V 20 kW and 208 V 10 kW: 49 dB at 70% load, 55 dB at 100% load | |
| Protection class | IP20 | |
| Color | RAL 9003, gloss level 85% | |

Heat Dissipation

480 V UPS in BTU/hr

| 20 kW UPS | Normal operation | ECO mode | eConversion | Battery operation |
|-----------|------------------|----------|-------------|-------------------|
| 25% load | 943 | 531 | 587 | 1009 |
| 50% load | 1305 | 587 | 654 | 1356 |
| 75% load | 1704 | 674 | 742 | 1903 |
| 100% load | 2225 | 794 | 841 | 2650 |

208 V UPS in BTU/hr

| 10 kW UPS | Normal operation | | | ECO mode | | |
|-----------|------------------|------|------|----------|-----|-----|
| | 200 | 208 | 220 | 200 | 208 | 220 |
| 25% load | 735 | 609 | 701 | 473 | 466 | 465 |
| 50% load | 1137 | 965 | 1045 | 555 | 548 | 546 |
| 75% load | 1706 | 1438 | 1518 | 659 | 651 | 630 |
| 100% load | 2494 | 2031 | 2128 | 796 | 772 | 746 |

| 10 kW UPS | eConversion | | | Battery operation | | |
|-----------|-------------|-----|-----|-------------------|------|------|
| | 200 | 208 | 220 | 200 | 208 | 220 |
| 25% load | 473 | 460 | 459 | 1032 | 902 | 1000 |
| 50% load | 556 | 552 | 538 | 1248 | 1167 | 1184 |
| 75% load | 659 | 641 | 629 | 1591 | 1511 | 1476 |
| 100% load | 787 | 763 | 731 | 2062 | 1935 | 1878 |

UPS Shipping Weights and Dimensions

| | Weight kg (lbs) | Height mm (in) | Width mm (in) | Depth mm (in) |
|-----------------------------|-----------------|----------------|---------------|---------------|
| UPS with one battery string | 270 (595) | 1680 (66.14) | 640 (25.19) | 990 (38.98) |

UPS Weights and Dimensions

| | Weight kg (lbs) | Height mm (in) | Width mm (in) | Depth mm (in) |
|-----------------------------|-----------------|----------------|---------------|---------------|
| UPS with one battery string | 245 (540) | 1485 (58.46) | 333 (13.11) | 847 (33.35) |

NOTE: One battery module weighs approximately 32 kg (70.5 lbs). One battery string consists of four battery modules.

Clearance

NOTE: Clearance dimensions are published for airflow and service access only. Consult with the local safety codes and standards for additional requirements in your local area.

NOTE: The required minimum rear clearance is 150 mm (5.91 in).

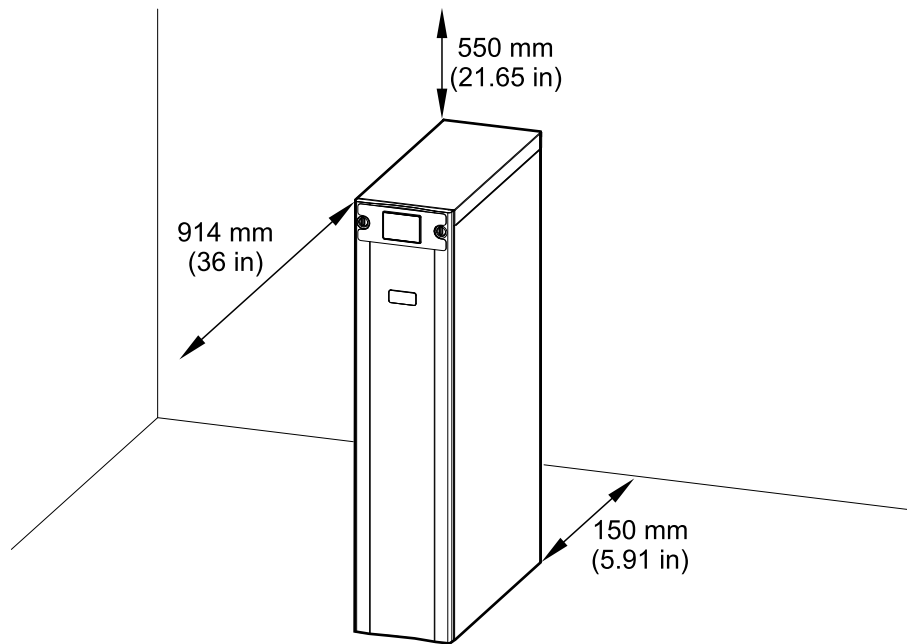

Drawings

NOTE: A comprehensive set of drawings is available on www.se.com.

NOTE: These drawings are for reference ONLY – subject to change without notice.

20 kW 480 V and 10 kW 208 V

SINGLE MAINS (ADJACENT BATTERY)

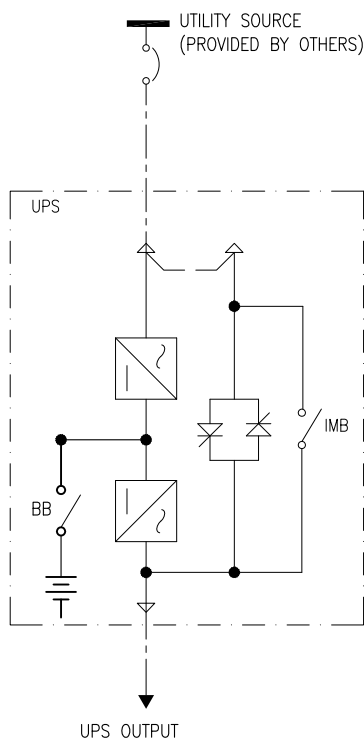

DUAL MAINS (ADJACENT BATTERY)

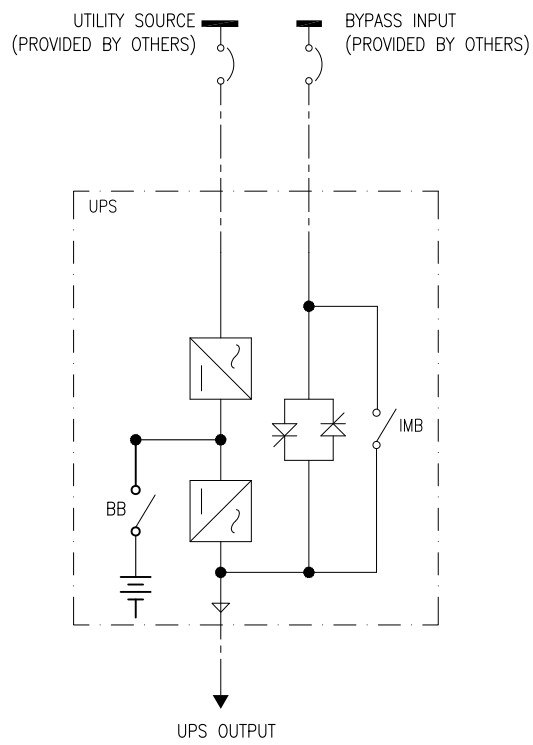

Options

Configuration Options

- eConversion mode
- Compact design, high density technology, and modular architecture
- Internal battery modules
- Single or dual mains
- Up to 4+0 UPSs in parallel for capacity
- Up to 3+1 UPSs in parallel for redundancy
- Rear cable entry
- EcoStruxure IT compatible
- Generator compatible
- Touchscreen LCD
- Replacement of power module in any operation mode (Live Swap)⁵
- ECO mode

5. In all systems configured for Live Swap.

Hardware Options

See Weights and Dimensions for Options, page 135.

NOTE: All hardware options listed here may not be available in all regions.

Power Module

- Power module 20 kW 480 V/10 kW 208 V (GVPM20KD)

Maintenance Bypass Panel

Maintenance bypass panel for complete isolation of the UPS during service operations. Only for single UPS.

- 10-30 kW 208 V, 20-60 kW 480 V maintenance bypass panel (GVSBPSU60G-WP)

Optional Installation Kits

- Seismic kit for UPS (GVSOPT017)
- Parallel kit for UPS (GVSOPT006)
- Live Swap kit for the UPS (GVSOPT039)

Optional Network Management Card

- Network Management Card LCES2 with Modbus, Ethernet and AUX sensors (AP9644)

Air Filter

- Air filter kit (GVSOPT015)

Battery Modules

7 Ah smart battery modules.

- Galaxy VS 7 Ah Smart Battery Module (GVSBTU)
- Galaxy VS 7 Ah Smart Modular Battery String (GVSBT4)

UPS with Internal Batteries Up to 4 Battery Strings

Single System Overview

| | |
|------|---|
| UIB | Unit input breaker |
| SSIB | Static switch input breaker |
| IMB | Internal maintenance breaker |
| UOB | Unit output breaker |
| BB | Battery breaker in UPS for internal batteries and in external battery solution (if present) |

Single System – Single Mains

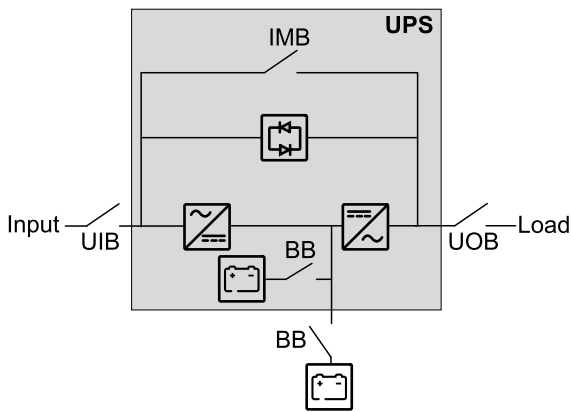

Single System – Dual Mains

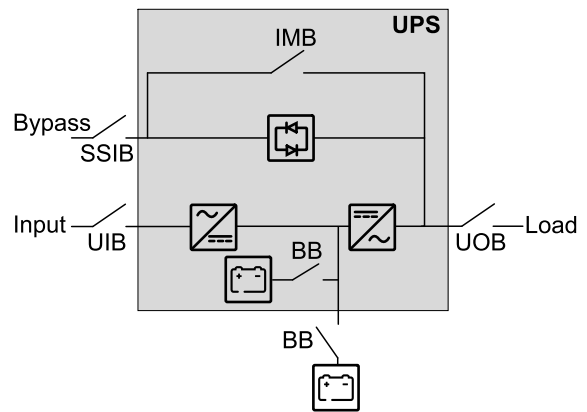

Parallel System Overview

| | |
|------|---|
| UIB | Unit input breaker |
| SSIB | Static switch input breaker |
| IMB | Internal maintenance breaker |
| UOB | Unit output breaker |
| SIB | System isolation breaker |
| BB | Battery breaker in UPS for internal batteries and in external battery solution (if present) |
| MBB | External maintenance bypass breaker |

Simplified 1+1 Parallel Systems

Galaxy VS can support 2 UPSs in a simplified 1+1 parallel system for redundancy with shared unit input breaker UIB and static switch input breaker SSIB.

Simplified 1+1 Parallel System – Single Mains

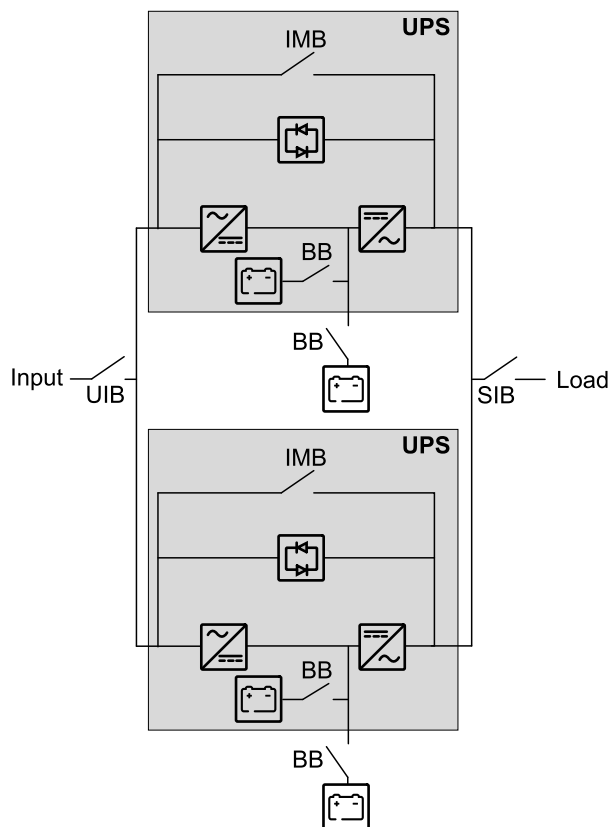

Simplified 1+1 Parallel System – Dual Mains

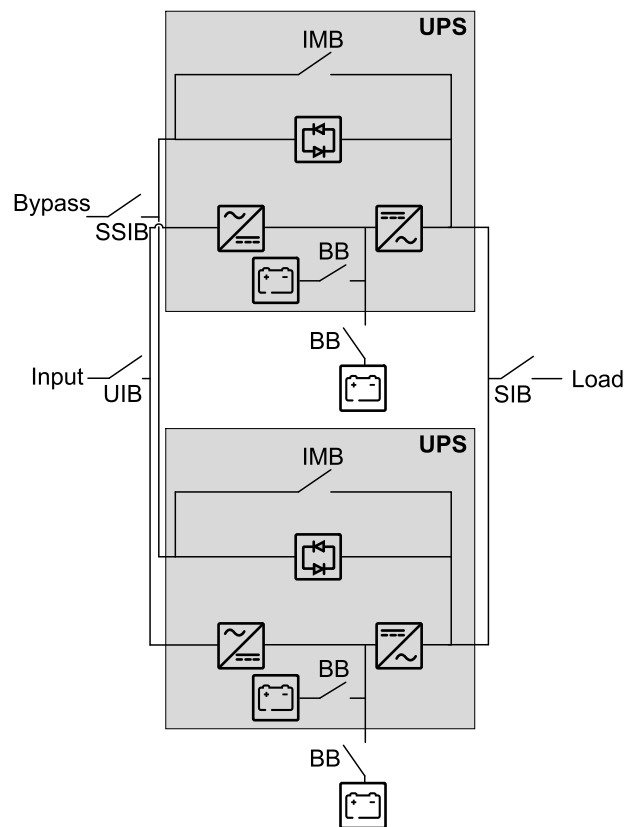

Parallel Systems with Individual Unit Input Breaker UIB and Static Switch Input Breaker SSIB

Galaxy VS can support up to 4 UPSs in parallel for capacity and up to 3+1 UPSs in parallel for redundancy with individual unit input breaker UIB and static switch input breaker SSIB.

NOTE: The internal maintenance breaker IMB can only be used in a simplified 1+1 parallel system. In any other parallel system, an external maintenance bypass breaker MBB must be provided and the internal maintenance breaker IMB* must be padlocked in the open position.

Parallel System – Single Mains

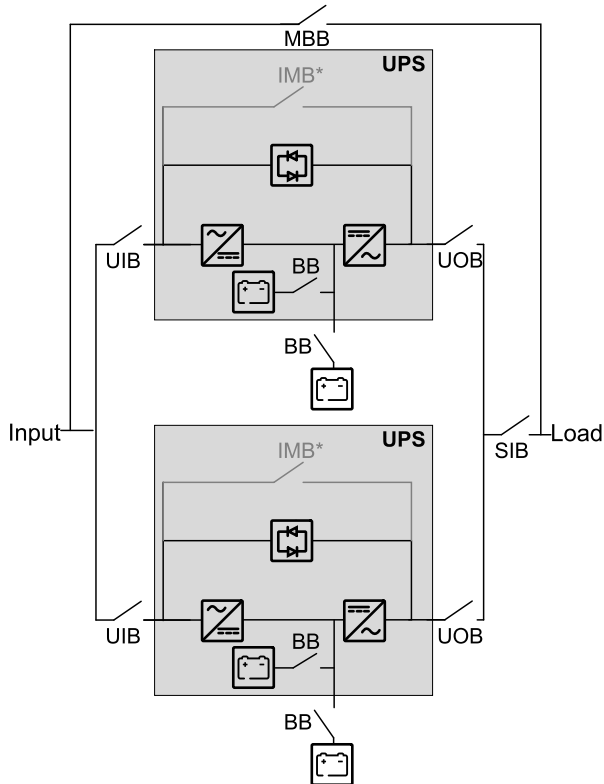

Parallel System – Dual Mains

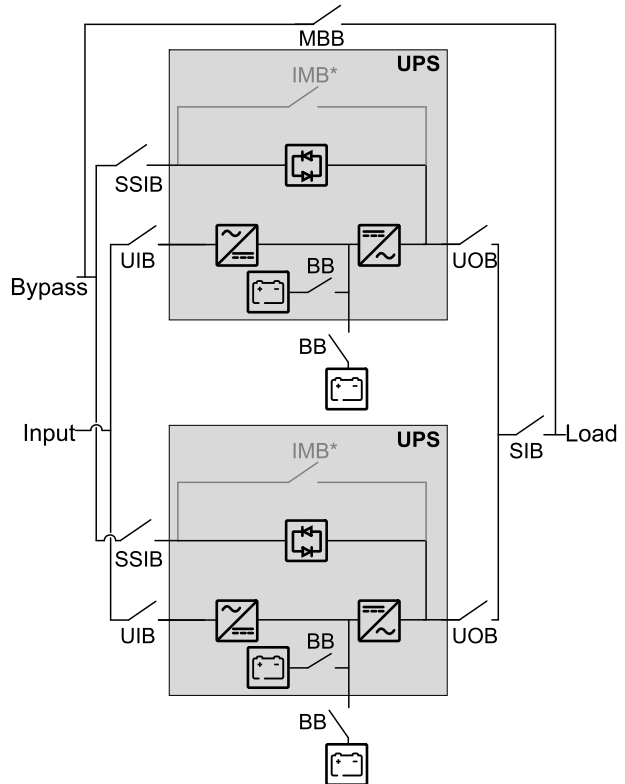

Parallel Systems with Shared Unit Input Breaker UIB and Static Switch Input Breaker SSIB

Galaxy VS can support up to 4 UPSs in parallel for capacity and up to 3+1 UPSs in parallel for redundancy with shared unit input breaker UIB and static switch input breaker SSIB.

NOTE: The internal maintenance breaker IMB can only be used in a simplified 1+1 parallel system. In any other parallel system, an external maintenance bypass breaker MBB must be provided and the internal maintenance breaker IMB* must be padlocked in the open position.

Parallel System – Single Mains

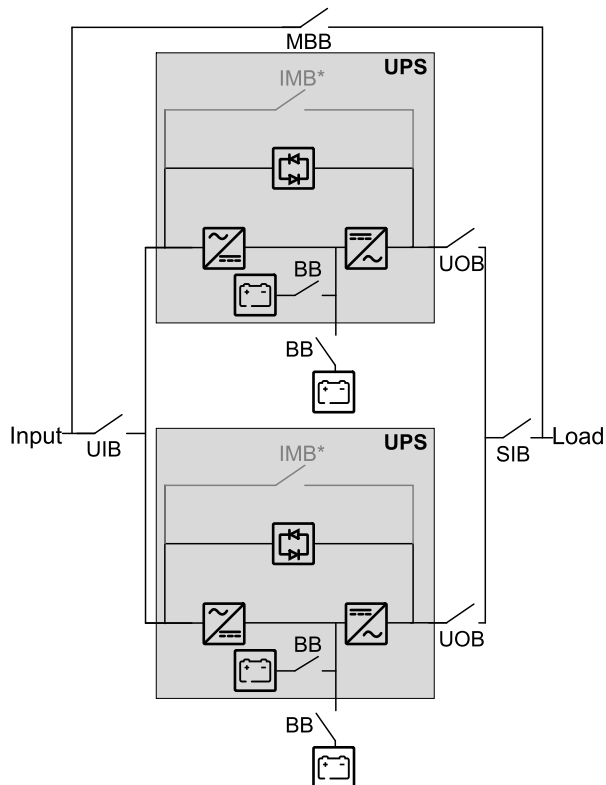

Parallel System – Dual Mains

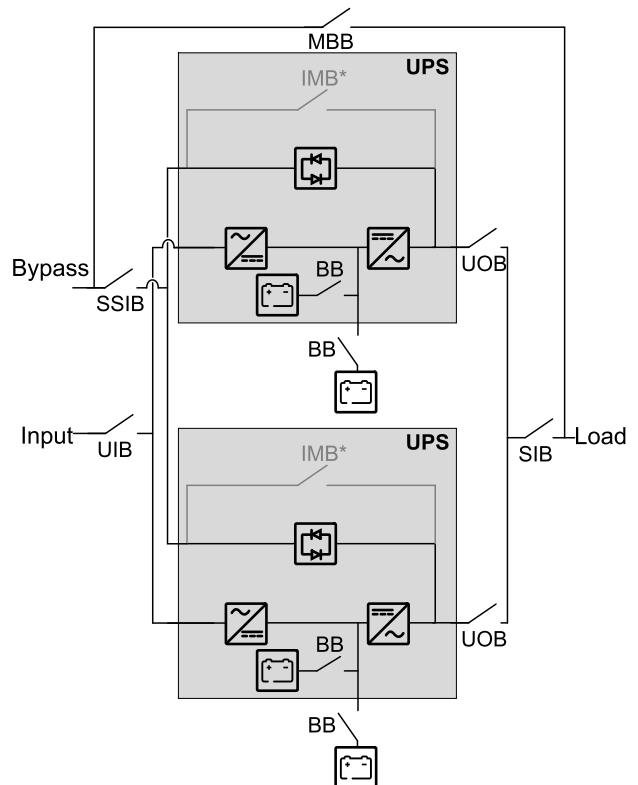

Input Voltage Window

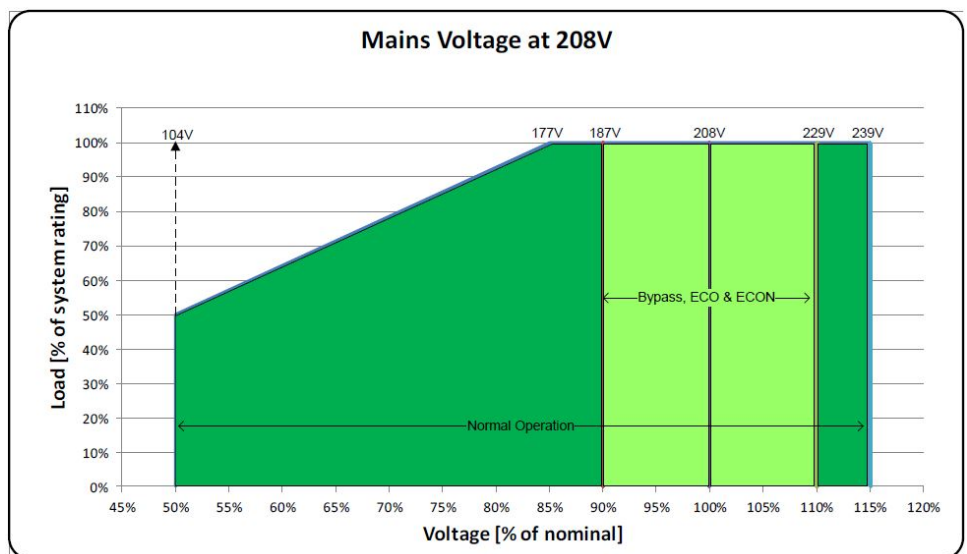
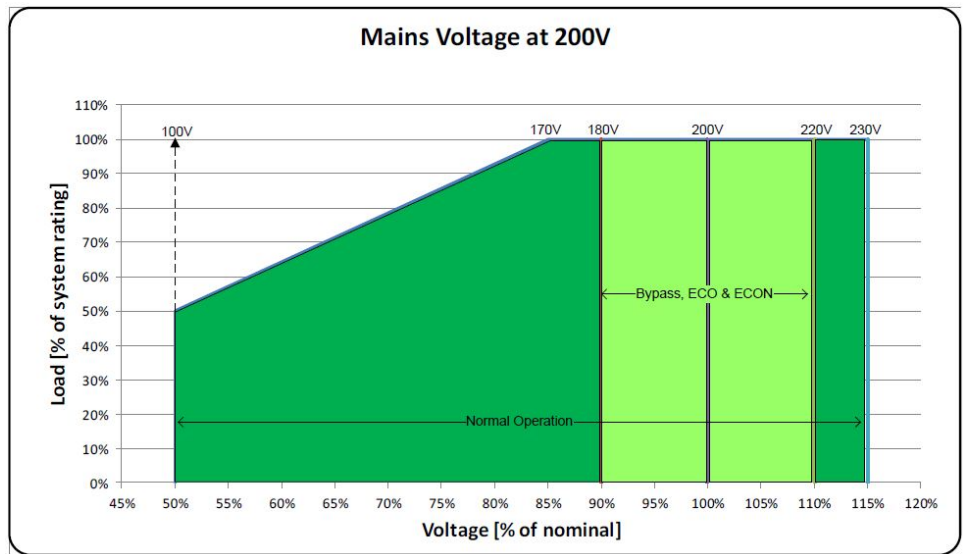
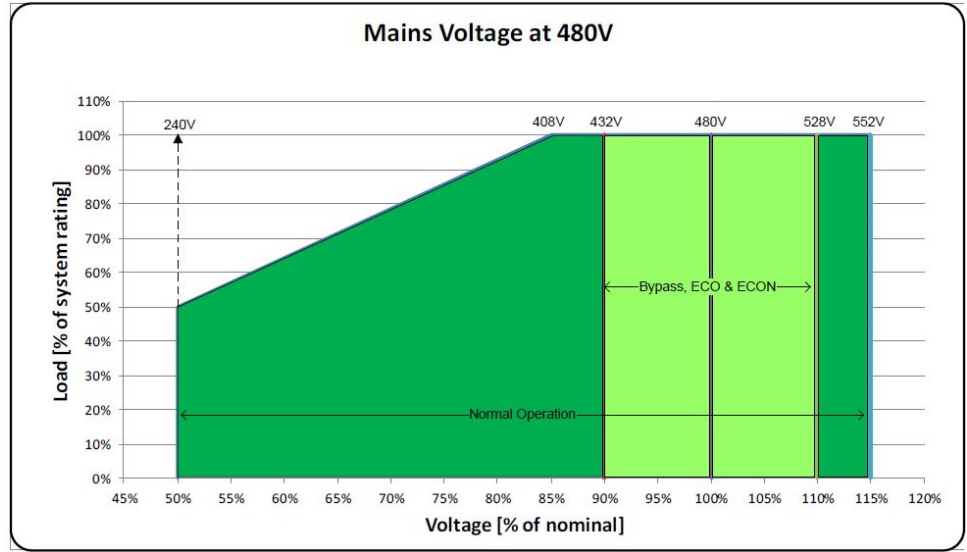

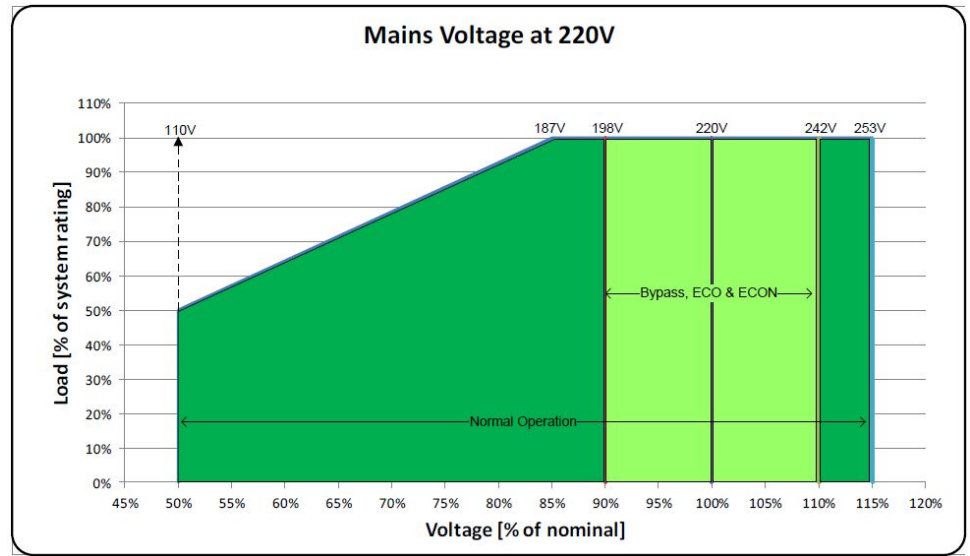

Inverter Short Circuit Capabilities (Bypass not Available)

IK1 – Short Circuit between a Phase and Neutral

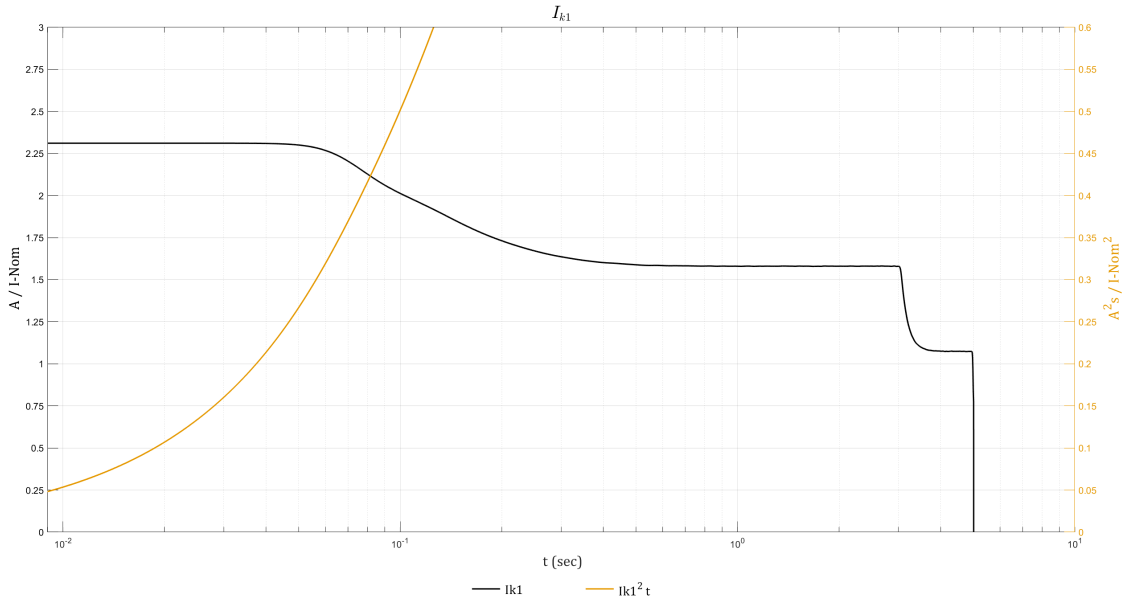

IK1 480 V

| S [kVA] | 10ms; I[A]/I ² t [A ² t] | 20ms; I[A]/I ² t [A ² t] | 30ms; I[A]/I ² t [A ² t] | 100ms; I[A]/I ² t [A ² t] | 1s; I[A]/I ² t [A ² t] |
|---------|--|--|--|---|--|
| 20 | 56 / 31 | 56 / 62 | 56 / 93 | 48 / 290 | 38 / 1674 |
| 30 | 83 / 70 | 83 / 140 | 83 / 210 | 73 / 650 | 57 / 3770 |
| 40 | 111 / 120 | 111 / 250 | 111 / 370 | 97 / 1160 | 76 / 6700 |
| 50 | 139 / 190 | 139 / 390 | 139 / 580 | 121 / 1810 | 95 / 10460 |

IK1 208 V

| S [kVA] | 10ms; I[A]/I ² t [A ² t] | 20ms; I[A]/I ² t [A ² t] | 30ms; I[A]/I ² t [A ² t] | 100ms; I[A]/I ² t [A ² t] | 1s; I[A]/I ² t [A ² t] |
|---------|--|--|--|---|--|
| 10 | 64 / 41 | 64 / 82 | 64 / 123 | 56 / 386 | 44 / 2229 |
| 15 | 96 / 93 | 96 / 185 | 96 / 278 | 84 / 869 | 66 / 5015 |
| 20 | 128 / 160 | 128 / 330 | 128 / 490 | 112 / 1550 | 88 / 8920 |
| 25 | 160 / 260 | 160 / 510 | 160 / 770 | 140 / 2420 | 110 / 13930 |

IK2 – Short Circuit between Two Phases

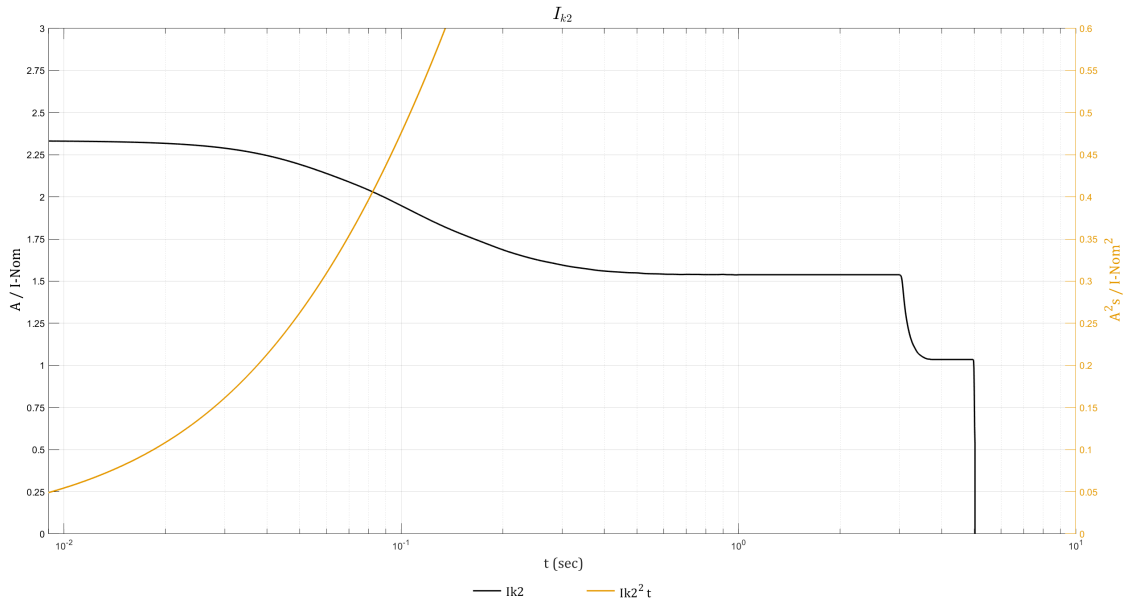

IK2 480 V

| S [kVA] | 10ms; I[A]/I ² t [A ² t] | 20ms; I[A]/I ² t [A ² t] | 30ms; I[A]/I ² t [A ² t] | 100ms; I[A]/I ² t [A ² t] | 1s; I[A]/I ² t [A ² t] |
|---------|--|--|--|---|--|
| 20 | 56 / 31 | 56 / 63 | 56 / 94 | 47 / 276 | 37 / 1586 |
| 30 | 84 / 70 | 84 / 140 | 84 / 210 | 70 / 620 | 55 / 3570 |
| 40 | 112 / 130 | 112 / 250 | 112 / 370 | 94 / 1100 | 74 / 6350 |
| 50 | 140 / 200 | 139 / 390 | 139 / 580 | 117 / 1720 | 92 / 9910 |

IK2 208 V

| S [kVA] | 10ms; I[A]/I ² t [A ² t] | 20ms; I[A]/I ² t [A ² t] | 30ms; I[A]/I ² t [A ² t] | 100ms; I[A]/I ² t [A ² t] | 1s; I[A]/I ² t [A ² t] |
|---------|--|--|--|---|--|
| 10 | 65 / 42 | 64 / 84 | 64 / 125 | 54 / 367 | 43 / 2112 |
| 15 | 97 / 94 | 96 / 188 | 96 / 280 | 81 / 825 | 64 / 4752 |
| 20 | 129 / 170 | 129 / 330 | 129 / 500 | 108 / 1470 | 85 / 8450 |
| 25 | 162 / 260 | 161 / 520 | 161 / 780 | 135 / 2290 | 107 / 13200 |

IK3 – Short Circuit between Three Phases

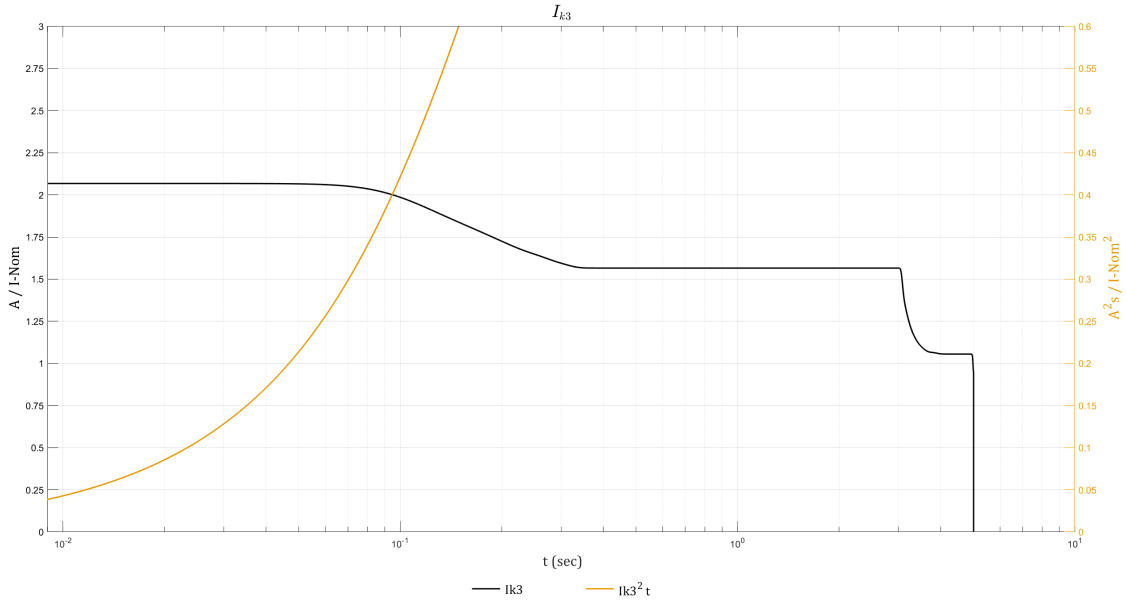

IK3 480 V

| S [kVA] | 10ms; I[A]/I ² t [A ² t] | 20ms; I[A]/I ² t [A ² t] | 30ms; I[A]/I ² t [A ² t] | 100ms; I[A]/I ² t [A ² t] | 1s; I[A]/I ² t [A ² t] |
|---------|--|--|--|---|--|
| 20 | 50 / 25 | 50 / 49 | 50 / 74 | 48 / 244 | 38 / 1593 |
| 30 | 75 / 60 | 75 / 110 | 75 / 170 | 72 / 550 | 57 / 3580 |
| 40 | 99 / 100 | 99 / 200 | 99 / 300 | 96 / 980 | 75 / 6370 |
| 50 | 124 / 150 | 124 / 310 | 124 / 460 | 119 / 1520 | 94 / 9960 |

IK3 208 V

| S [kVA] | 10ms; I[A]/I ² t [A ² t] | 20ms; I[A]/I ² t [A ² t] | 30ms; I[A]/I ² t [A ² t] | 100ms; I[A]/I ² t [A ² t] | 1s; I[A]/I ² t [A ² t] |
|---------|--|--|--|---|--|
| 10 | 57 / 33 | 57 / 66 | 57 / 99 | 55 / 325 | 43 / 2121 |
| 15 | 86 / 74 | 86 / 148 | 86 / 222 | 83 / 731 | 65 / 4772 |
| 20 | 115 / 130 | 115 / 260 | 115 / 400 | 110 / 1300 | 87 / 8480 |
| 25 | 143 / 210 | 143 / 410 | 143 / 620 | 138 / 2030 | 109 / 13260 |

Efficiency

480 V UPS

Normal Operation

| UPS rating | 20 kW | 30 kW | 40 kW | 50 kW |
|------------|-------|-------|-------|-------|
| 25% load | 94.9% | 94.7% | 95.2% | 95.8% |
| 50% load | 96.4% | 96.2% | 96.6% | 96.9% |
| 75% load | 96.8% | 96.7% | 97.0% | 97.1% |
| 100% load | 96.9% | 97.0% | 97.1% | 97.0% |

ECO Mode

| UPS rating | 20 kW | 30 kW | 40 kW | 50 kW |
|------------|-------|-------|-------|-------|
| 25% load | 97.1% | 97.7% | 98.2% | 98.4% |
| 50% load | 98.3% | 98.6% | 98.8% | 98.9% |
| 75% load | 98.7% | 98.9% | 99.0% | 99.1% |
| 100% load | 98.9% | 99.0% | 99.1% | 99.2% |

eConversion

| UPS rating | 20 kW | 30 kW | 40 kW | 50 kW |
|------------|-------|-------|-------|-------|
| 25% load | 96.5% | 96.4% | 97.2% | 97.7% |
| 50% load | 98.1% | 98.0% | 98.3% | 98.6% |
| 75% load | 98.6% | 98.5% | 98.7% | 98.9% |
| 100% load | 98.8% | 98.7% | 99.0% | 99.1% |

Battery Operation

| UPS rating | 20 kW | 30 kW | 40 kW | 50 kW |
|------------|-------|-------|-------|-------|
| 25% load | 93.5% | 91.1% | 92.9% | 94.1% |
| 50% load | 95.6% | 94.8% | 95.6% | 96.1% |
| 75% load | 96.2% | 95.9% | 96.3% | 96.4% |
| 100% load | 96.3% | 96.3% | 96.4% | 96.3% |

208 V UPS

| 10 kW | Normal operation | | | ECO mode | | | |
|-----------|------------------|-------|-------|----------|-------|-------|-------|
| | Voltage (V) | 200 | 208 | 220 | 200 | 208 | 220 |
| 25% load | | 93.3% | 92.1% | 92.4% | 94.5% | 94.3% | 94.5% |
| 50% load | | 94.6% | 94.0% | 94.2% | 96.7% | 96.8% | 96.8% |
| 75% load | | 94.5% | 94.1% | 94.4% | 97.5% | 97.5% | 97.6% |
| 100% load | | 94.1% | 93.7% | 94.2% | 97.8% | 97.9% | 97.9% |

| 10 kW | eConversion | | | Battery operation | | | |
|----------|-------------|-------|-------|-------------------|-------|-------|-------|
| | Voltage (V) | 200 | 208 | 220 | 200 | 208 | 220 |
| 25% load | | 94.4% | 94.3% | 94.4% | 89.3% | 90.5% | 89.6% |
| 50% load | | 96.7% | 96.8% | 96.7% | 93.3% | 93.7% | 93.6% |

| 10 kW | eConversion | | | Battery operation | | |
|-------------|-------------|-------|-------|-------------------|-------|-------|
| Voltage (V) | 200 | 208 | 220 | 200 | 208 | 220 |
| 75% load | 97.5% | 97.5% | 97.5% | 94.2% | 94.5% | 94.6% |
| 100% load | 97.8% | 97.9% | 97.9% | 94.4% | 94.7% | 94.9% |

| 15 kW | Normal operation | | | ECO mode | | |
|-------------|------------------|-------|-------|----------|-------|-------|
| Voltage (V) | 200 | 208 | 220 | 200 | 208 | 220 |
| 25% load | 91.8% | 92.3% | 92.0% | 95.4% | 95.4% | 95.5% |
| 50% load | 93.8% | 94.1% | 94.2% | 97.2% | 97.3% | 97.3% |
| 75% load | 94.2% | 94.5% | 94.6% | 97.7% | 97.7% | 97.8% |
| 100% load | 94.1% | 94.5% | 94.7% | 98.0% | 98.0% | 98.1% |

| 15 kW | eConversion | | | Battery operation | | |
|-------------|-------------|-------|-------|-------------------|-------|-------|
| Voltage (V) | 200 | 208 | 220 | 200 | 208 | 220 |
| 25% load | 94.8% | 94.7% | 94.8% | 88.1% | 87.8% | 87.9% |
| 50% load | 96.9% | 97.0% | 97.0% | 92.7% | 92.7% | 93.0% |
| 75% load | 97.7% | 97.7% | 97.6% | 94.1% | 94.2% | 94.5% |
| 100% load | 97.9% | 98.0% | 98.0% | 94.7% | 94.8% | 95.1% |

| 20 kW | Normal operation | | | ECO mode | | |
|-------------|------------------|-------|-------|----------|-------|-------|
| Voltage (V) | 200 | 208 | 220 | 200 | 208 | 220 |
| 25% load | 92.7% | 93.3% | 93.3% | 96.4% | 96.3% | 96.3% |
| 50% load | 94.1% | 94.5% | 94.7% | 97.6% | 97.7% | 97.8% |
| 75% load | 94.1% | 94.5% | 94.7% | 98.0% | 98.0% | 98.1% |
| 100% load | 93.7% | 94.3% | 94.5% | 98.2% | 98.2% | 98.3% |

| 20 kW | eConversion | | | Battery operation | | |
|-------------|-------------|-------|-------|-------------------|-------|-------|
| Voltage (V) | 200 | 208 | 220 | 200 | 208 | 220 |
| 25% load | 95.9% | 95.9% | 95.8% | 90.4% | 90.3% | 90.4% |
| 50% load | 97.5% | 97.5% | 97.5% | 93.8% | 93.9% | 94.2% |
| 75% load | 97.9% | 98.0% | 98.0% | 94.7% | 94.8% | 95.1% |
| 100% load | 98.2% | 98.2% | 98.2% | 94.9% | 95.0% | 95.4% |

| 25 kW | Normal operation | | | ECO mode | | |
|-------------|------------------|-------|-------|----------|-------|-------|
| Voltage (V) | 200 | 208 | 220 | 200 | 208 | 220 |
| 25% load | 93.4% | 93.8% | 93.8% | 96.9% | 96.9% | 96.9% |
| 50% load | 94.2% | 94.5% | 94.7% | 97.8% | 97.9% | 97.9% |
| 75% load | 93.8% | 94.4% | 94.6% | 98.1% | 98.2% | 98.3% |
| 100% load | 93.1% | 93.5% | 94.0% | 98.2% | 98.3% | 98.4% |

| 25 kW | eConversion | | | Battery operation | | |
|-------------|-------------|-------|-------|-------------------|-------|-------|
| Voltage (V) | 200 | 208 | 220 | 200 | 208 | 220 |
| 25% load | 96.7% | 96.5% | 96.6% | 91.8% | 91.8% | 91.9% |
| 50% load | 97.8% | 97.8% | 97.8% | 94.4% | 94.5% | 94.8% |
| 75% load | 98.1% | 98.2% | 98.2% | 94.9% | 95.0% | 95.3% |
| 100% load | 98.2% | 98.3% | 98.2% | 94.8% | 95.0% | 95.3% |

Derating Due to Load Power Factor

0.7 leading to 0.7 lagging without derating.

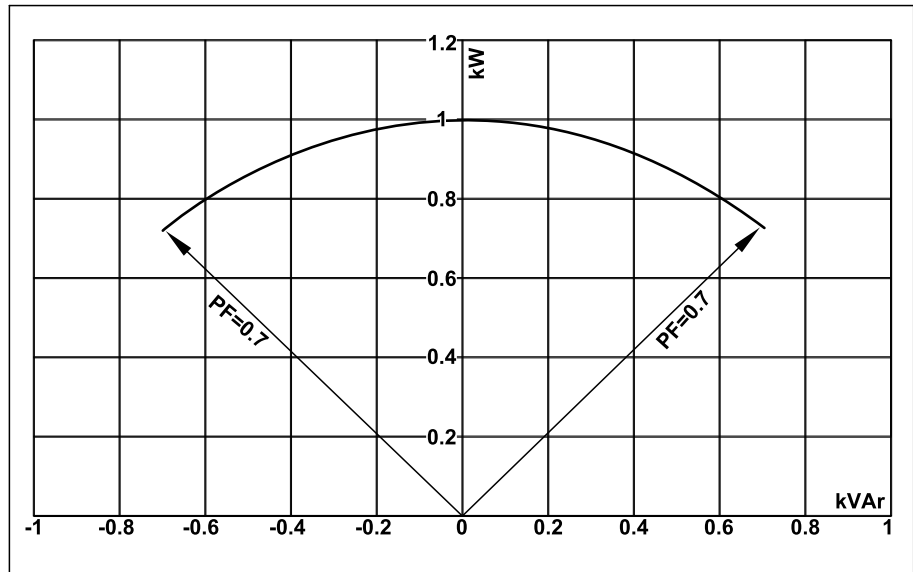

| UPS rating | UPS output | | | | | |
|------------|------------------|----------------|------------------|------------------|----------------|------------------|
| | Lagging | | | Leading | | |
| PF=1 | PF=0.7 | PF=0.8 | PF=0.9 | PF=0.9 | PF=0.8 | PF=0.7 |
| 10 kVA/kW | 10 kVA / 7 kW | 10 kVA / 8 kW | 10 kVA / 9 kW | 10 kVA / 9 kW | 10 kVA / 8 kW | 10 kVA / 7 kW |
| 15 kVA/kW | 15 kVA / 10.5 kW | 15 kVA / 12 kW | 15 kVA / 13.5 kW | 15 kVA / 13.5 kW | 15 kVA / 12 kW | 15 kVA / 10.5 kW |
| 20 kVA/kW | 20 kVA / 14 kW | 20 kVA / 16 kW | 20 kVA / 18 kW | 20 kVA / 18 kW | 20 kVA / 16 kW | 20 kVA / 14 kW |
| 25 kVA/kW | 25 kVA / 17.5 kW | 25 kVA / 20 kW | 25 kVA / 22.5 kW | 25 kVA / 22.5 kW | 25 kVA / 20 kW | 25 kVA / 17.5 kW |
| 30 kVA/kW | 30 kVA / 21 kW | 30 kVA / 24 kW | 30 kVA / 27 kW | 30 kVA / 27 kW | 30 kVA / 24 kW | 30 kVA / 21 kW |
| 40 kVA/kW | 40 kVA / 28 kW | 40 kVA / 32 kW | 40 kVA / 36 kW | 40 kVA / 36 kW | 40 kVA / 32 kW | 40 kVA / 28 kW |
| 50 kVA/kW | 50 kVA / 35 kW | 50 kVA / 40 kW | 50 kVA / 45 kW | 50 kVA / 45 kW | 50 kVA / 40 kW | 50 kVA / 35 kW |

Batteries

End of Discharge Voltage

The voltage is 1.6 to 1.75 per cell depending on discharge ratio.

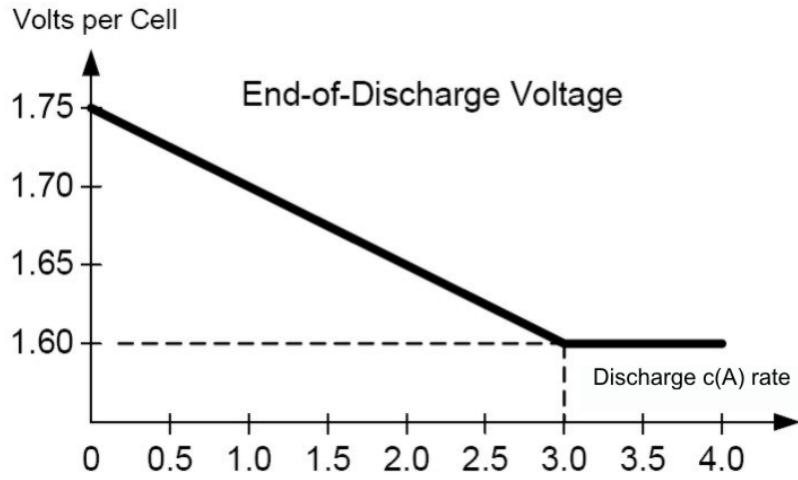

Battery Voltage Window

| | Boost 2.38 Vpc | Nominal 2.0 Vpc | Minimum 1.6 Vpc |
|---------------------|-----------------------|------------------------|------------------------|
| Battery voltage (V) | 571.2 | 480 | 384 |

Battery Runtimes in Minutes

480 V UPS

| UPS rating | 20 kW | 30 kW | 40 kW | 50 kW |
|-----------------------------------|-------|-------|-------|-------|
| Number of modular battery strings | | | | |
| 1 | NA | NA | NA | NA |
| 2 | 11 | 6.1 | NA | NA |
| 3 | 18.5 | 10.5 | 7.3 | 5.2 |
| 4 | 27 | 16 | 10.5 | 8 |
| 5 | 35.5 | 21.5 | 14.5 | 10.5 |
| 6 | 45 | 27 | 18.5 | 14 |
| 7 | 54 | 32.5 | 22.5 | 17 |
| 8 | 63.5 | 38.5 | 27 | 20 |
| 9 | 73.5 | 44.5 | 31 | 23.5 |
| 10 | 83.5 | 51 | 35.5 | 27 |
| 11 | 94 | 57 | 40 | 30.5 |
| 12 | 100 | 63.5 | 44.5 | 34 |
| 13 | 115 | 70 | 49 | 37.5 |
| 14 | 125 | 76.5 | 54 | 41 |
| 15 | 135 | 83.5 | 58.5 | 44.5 |
| 16 | 145 | 90 | 63.5 | 48 |
| 17 | 155 | 97 | 68 | 52 |
| 18 | 165 | 100 | 73 | 56 |
| 19 | 180 | 110 | 78 | 59.5 |
| 20 | 190 | 115 | 83 | 63.5 |
| 21 | 200 | 125 | 88 | 67.5 |
| 22 | 215 | 130 | 93.5 | 71 |
| 23 | 225 | 135 | 98.5 | 75 |
| 24 | 235 | 145 | 100 | 79 |
| 25 | 250 | 150 | 105 | 83 |
| 26 | 260 | 160 | 110 | 87.5 |
| 27 | 275 | 165 | 115 | 91.5 |
| 28 | 285 | 175 | 125 | 95.5 |

208 V UPS

| UPS rating | 10 kW | 15 kW | 20 kW | 25 kW |
|-----------------------------------|-------|-------|-------|-------|
| Number of modular battery strings | | | | |
| 1 | 10.5 | 6.1 | NA | NA |
| 2 | 26.5 | 16 | 10.5 | 7.9 |
| 3 | 44 | 26.5 | 18.5 | 13.5 |
| 4 | 63 | 38.5 | 26.5 | 20 |
| 5 | 82.5 | 50.5 | 35.5 | 26.5 |
| 6 | 100 | 63 | 44 | 33.5 |

| UPS rating | 10 kW | 15 kW | 20 kW | 25 kW |
|-----------------------------------|-------|-------|-------|-------|
| Number of modular battery strings | | | | |
| 7 | 120 | 76.5 | 53.5 | 40.5 |
| 8 | 145 | 89.5 | 63 | 47.5 |
| 9 | 165 | 100 | 72.5 | 55 |
| 10 | 190 | 115 | 82.5 | 62.5 |
| 11 | 210 | 130 | 92.5 | 70.5 |
| 12 | 235 | 145 | 100 | 78 |
| 13 | 260 | 160 | 110 | 86 |
| 14 | 280 | 175 | 120 | 94 |
| 15 | 305 | 190 | 135 | 100 |
| 16 | 330 | 205 | 145 | 110 |
| 17 | 355 | 220 | 155 | 115 |
| 18 | 380 | 235 | 165 | 125 |
| 19 | 405 | 250 | 175 | 135 |
| 20 | 435 | 265 | 190 | 140 |
| 21 | 460 | 285 | 200 | 150 |
| 22 | 485 | 300 | 210 | 160 |
| 23 | 510 | 315 | 225 | 170 |
| 24 | 540 | 335 | 235 | 180 |
| 25 | 565 | 350 | 245 | 185 |
| 26 | 590 | 365 | 260 | 195 |
| 27 | 620 | 385 | 270 | 205 |
| 28 | 645 | 400 | 280 | 215 |

Compliance

| | |
|----------------|--|
| Safety | IEC 62040-1: 2008-06, 1st edition Uninterruptible Power Systems (UPS) - Part 1: General and safety requirements for UPS IEC 62040-1: 2013-01, 1st edition amendment 1 UL 1778 5th edition |
| EMC/EMI/RFI | IEC 62040-2: 2005-10, 2nd edition Uninterruptible Power Systems (UPS) - Part 2: Electromagnetic compatibility (EMC) requirements C2 FCC Part 15 Subpart B, Class A IEEE C62.41-1991 Location Category B2, IEEE Recommended Practice on Surge Voltages in Low-Voltage AC Power Circuits |
| Transportation | IEC 60721-4-2 Level 2M1 |
| Seismic | ICC-ES AC 156 (2015): OHSPD Pre-approved; Sds=1.33 g for z/h=1 and Sds=1.63 g for z/h=0; Ip= 1.5 |

Performance

Performance in accordance with: IEC 62040-3: 2021, 3rd edition Uninterruptible Power Systems (UPS) - Part 3: Method of specifying the performance and test requirements.

Regional Seismic Compliance

Certificate available upon request.

| Country/Region | Code ID | Hazard level ground | Hazard level roof |
|---------------------|---------------------------------|-----------------------------------|-----------------------------------|
| Argentina | INPRES-CIRSOC103 | Zone 4 | Zone 4 |
| Australia | AS 1170.4-2007 | Z = 0.22 | Z = 0.22 |
| Canada ⁶ | 2020 NBCC | S _a = 2.0 | S _a = 1.46 |
| Chile | NCh 433.Of1996 | Zone 3 | Zone 2 |
| China | GB 50011-2010 (2016) | $\alpha_{Max} = 1.4$ | $\alpha_{Max} = 1.2$ |
| Europe | Eurocode 8 EN1998-1 | $\alpha_{gR} = 0.45$ | $\alpha_{gR} = 0.3$ |
| India | IS 1893 (Part 1) : 2016 | Z = 0.36 | Z = 0.36 |
| Japan | Building Standard Law | Zone A | Zone A |
| New Zealand | NZS 1170.5:2004+A1 | Z = 0.6 | Z = 0.42 |
| Peru | N.T.E. - E.030 | Zone 4 | Zone 4 |
| Russia | SNIP II-7-81 (SP 14.13330.2014) | MSK 10 | MSK 9 |
| Taiwan | CPA 2011 Seismic Design Code | S _s ^D = 0.8 | S _s ^D = 0.8 |
| U.S.A. ⁶ | ASCE 7-16 / IBC 2018 | S _{DS} = 2.0 | S _{DS} = 1.47 |

6. OSHPD Pre-approved in accordance with AC156 test protocol.

Communication and Management

| | |
|---------------------------|---|
| Local area network | 1 Gbps – 1 port as default |
| Modbus | Modbus (SCADA) |
| Output relays | 4 x SELV configurable |
| Input contacts | 4 x SELV configurable |
| Standard control panel | 4.3 inch touchscreen display |
| Audible alarm | Yes |
| Emergency Power Off (EPO) | Options: <ul style="list-style-type: none"> • Normally Open (NO) • Normally Closed (NC) • External 24 VDC SELV |
| External switchgear | UIB UOB SSIB MBB SIB |
| External synchronization | No |
| Battery monitoring | Available for modular batteries |

EPO

EPO Configurations (640–4864 terminal J6600, 1–9)

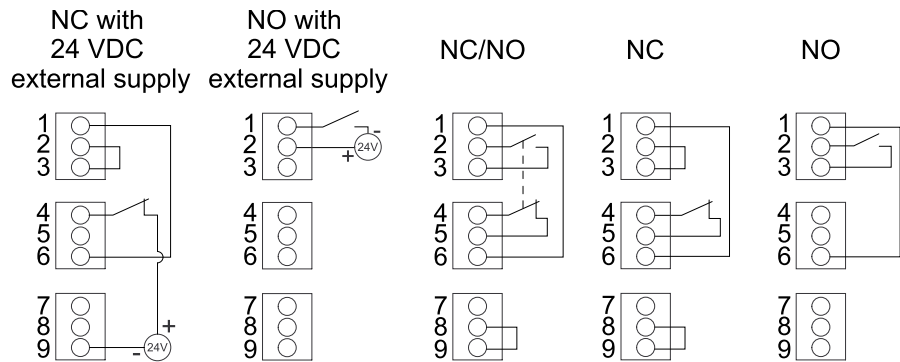

The EPO input supports 24 VDC.

NOTE: The default setting for the EPO activation is to turn off the inverter.

If you want the EPO activation to transfer the UPS into forced static bypass operation instead, please contact Schneider Electric.

Configurable Input Contacts and Output Relays

Input Contacts

Four input contacts are available and can be configured to indicate a given event via the display. The input contacts support 24 VDC 10 mA.

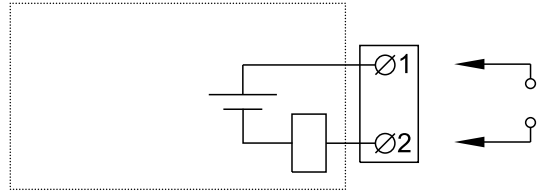

| Name | Description | Location |
|-------------------------|----------------------------|------------------------------|
| IN _1 (input contact 1) | Configurable input contact | 640-4864 terminal J6616, 1–2 |
| IN _2 (input contact 2) | Configurable input contact | 640-4864 terminal J6616, 3–4 |
| IN _3 (input contact 3) | Configurable input contact | 640-4864 terminal J6616, 5–6 |
| IN _4 (input contact 4) | Configurable input contact | 640-4864 terminal J6616, 7–8 |

Output Relays

Four output relays are available and can be configured to activate on one or more events via the display.

The output relays support 24 VAC/VDC 1 A. All external circuitry must be fused with maximum 1 A fast acting fuses.

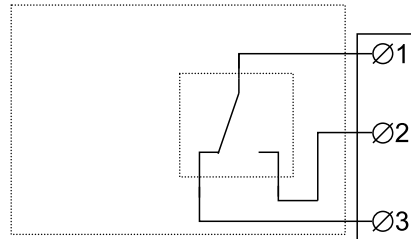

| Name | Description | Location |
|-------------------------|---------------------------|--------------------------------|
| OUT _1 (output relay 1) | Configurable output relay | 640-4864 terminal J6617, 1–3 |
| OUT _2 (output relay 2) | Configurable output relay | 640-4864 terminal J6617, 4–6 |
| OUT _3 (output relay 3) | Configurable output relay | 640-4864 terminal J6617, 7–9 |
| OUT _4 (output relay 4) | Configurable output relay | 640-4864 terminal J6617, 10–12 |

Energized check mode: When this mode is enabled, it means that the output relay is activated when the events associated with the output relay are not present (normally activated). **Energized check mode** is individually set for each output relay and makes it possible to detect if the power supply to the output relays is lost, as all output relays will deactivate and the events associated with the output relays will be indicated as present.

Specifications

Specifications for 480 V Systems

The supply for input and bypass must be solid-grounded WYE transformers. Delta input supply for either input or bypass is not permitted.

The UPS system must be installed as a separately derived system. Leakage currents will occur in the bonding jumper and the technical/system earth.

Input Specifications 480 V

| UPS rating | 20 kW | 30 kW | 40 kW | 50 kW |
|----------------------------------|--|-------|-------|-------|
| Connections | 3-wire (L1, L2, L3, G) WYE or 4-wire (L1, L2, L3, N, G) WYE (single mains) 3-wire (L1, L2, L3, G) WYE (dual mains) ⁷ | | | |
| Input voltage range (V) | 408-552 | | | |
| Frequency range (Hz) | 40-70 | | | |
| Nominal input current (A) | 25 | 37 | 50 | 62 |
| Maximum input current (A) | 30 | 45 | 60 | 74 |
| Input current limitation (A) | 31 | 47 | 62 | 77 |
| Input power factor | 0.99 for load greater than 50% 0.95 for load greater than 25% | | | |
| Total harmonic distortion (THDI) | <3% at full linear load (symmetrical) | | | |
| Maximum short circuit rating | 65 kA RMS | | | |
| Protection | Built-in backfeed protection and fuses | | | |
| Ramp-in | Programmable and adaptive 1-40 seconds | | | |

7. TN and TT power distribution systems are supported. Corner (line) grounding is not supported.

Bypass Specifications 480 V

| UPS rating | 20 kW | 30 kW | 40 kW | 50 kW |
|---|---|-------|-------|-------|
| Connections | 3-wire (L1, L2, L3, G) WYE or 4-wire (L1, L2, L3, N, G) WYE ⁸ | | | |
| Bypass voltage range (V) | 432-528 | | | |
| Frequency range (Hz) | 50/60 ± 1, 50/60 ± 3, 50/60 ± 10 (user selectable) | | | |
| Nominal bypass current (A) | 24 | 36 | 49 | 61 |
| Nominal neutral current (A) | 42 | 62 | 83 | 104 |
| Maximum short circuit rating ⁹ | 65 kA RMS | | | |
| Protection | Built-in backfeed protection and fuses Internal fuse specifications: Rated 200 A, prearcing 5.25 kA ² s | | | |

Output Specifications 480 V

NOTE: The number of output connections must match the number of input wires in a single mains system or bypass wires in a dual mains system.

| UPS rating | 20 kW | 30 kW | 40 kW | 50 kW |
|----------------------------------|---|-------|-------|-------|
| Connections | 3-wire (L1, L2, L3, G, GEC ¹⁰) or 4-wire (L1, L2, L3, N, G) | | | |
| Voltage regulation | Symmetrical load ± 1% Asymmetrical load ± 3% | | | |
| Overload capacity | 150% for 1 minute (in normal operation) 125% for 10 minutes (in normal operation) 125% for 1 minute (in battery operation) 125% continuous (bypass operation) 1000% for 100 milliseconds (bypass operation) | | | |
| Dynamic load response | ± 5% after 2 milliseconds ± 1% after 50 milliseconds | | | |
| Output power factor | 1 | | | |
| Nominal output current (A) | 24 | 36 | 48 | 60 |
| Frequency regulation (Hz) | 50/60 Hz bypass synchronized – 50/60 Hz ± 0.1% free-running | | | |
| Synchronized slew rate (Hz/sec) | Programmable to 0.25, 0.5, 1, 2, 4, 6 | | | |
| Total harmonic distortion (THDU) | <1% for linear load <5% for non-linear load | | | |
| Load crest factor | 2.5 | | | |
| Load power factor | From 0.7 leading to 0.7 lagging without any derating | | | |

8. TN and TT power distribution systems are supported. Corner (line) grounding is not supported.

9. Conditioned by the internal fuse rated 200 A, prearcing 5.25 kA²s.

10. Per NEC 250.30.

Battery Specifications 480 V

⚡⚠ DANGER

HAZARD OF ELECTRIC SHOCK, EXPLOSION, OR ARC FLASH

Protection of the energy storage device: An overcurrent protective device must be located in close proximity to the energy storage device.

Failure to follow these instructions will result in death or serious injury.

All values are based on 40 battery blocks.

| UPS rating | 20 kW | 30 kW | 40 kW | 50 kW |
|--|--|-------|-------|-------|
| Charging power in % of output power at 0-40% load | 80% | | | |
| Charging power in % of output power at 100% load | 20% | | | |
| Maximum charging power (at 0-40% load) (kW) | 16 | 24 | 32 | 40 |
| Maximum charging power (at 100% load) (kW) | 4 | 6 | 8 | 10 |
| Nominal battery voltage (VDC) | 480 | | | |
| Nominal float voltage (VDC) | 545 | | | |
| Maximum boost voltage (VDC) | 571 | | | |
| Temperature compensation (per cell) | -3.3mV/°C, for T ≥ 25 °C – 0mV/°C, for T < 25 °C | | | |
| End of discharge voltage (full load) (VDC) | 384 | | | |
| Battery current at full load and nominal battery voltage (A) | 43 | 65 | 87 | 108 |
| Battery current at full load and minimum battery voltage (A) | 54 | 81 | 108 | 135 |
| Ripple current | < 5% C20 (5 minute runtime) | | | |
| Battery test | Manual/automatic (selectable) | | | |
| Maximum short circuit rating | 10 kA | | | |

Recommended Cable Sizes 480 V

⚠ ⚠ DANGER

HAZARD OF ELECTRIC SHOCK, EXPLOSION, OR ARC FLASH

All wiring must comply with all applicable national and/or electrical codes. The maximum allowable cable size is 1/0 AWG.

Failure to follow these instructions will result in death or serious injury.

The maximum number of cable connections per busbar: 2 on input/output/bypass busbars; 2 on DC+/DC- busbars; 4 on N busbar; 5 on G busbar.

NOTE: Overcurrent protection is to be provided by others.

Cable sizes in this manual are based on Table 310.15 (B)(16) of the National Electrical Code (NEC) with the following assertions:

- 90 °C (194 °F) conductors (75 °C (167 °F) termination)
- An ambient temperature of 30 °C (86 °F)
- Use of copper conductors

If the ambient temperature is greater than 30 °C (86 °F), larger conductors are to be selected in accordance with the correction factors of the NEC.

Equipment grounding conductors (EGC) are sized in accordance with NEC Article 250.122 and Table 250.122.

NOTE: Recommended cable sizes and maximum allowable cable size may vary for the auxiliary products. Not all auxiliary products support aluminum cables. Refer to the installation manual provided with the auxiliary product.

NOTE: The DC cable sizes given here are recommendations – Always follow the specific instructions in the battery solution documentation for DC cable sizes and DC EGC cable sizes and ensure that the DC cable sizes match the battery breaker rating.

NOTE: Neutral conductor is sized to handle 1.73 times phase current in case of high harmonic content from non-linear loads. If non or less harmonic currents are expected, neutral conductor can be sized accordingly but not less than the phase conductor.

Copper

| UPS rating | 20 kW | 30 kW | 40 kW | 50 kW |
|-----------------------------------|-------|-------|-------|-------|
| Input phases (AWG/kcmil) | 8 | 6 | 4 | 3 |
| Input EGC (AWG/kcmil) | 10 | 8 | 8 | 6 |
| Bypass/output phases (AWG/kcmil) | 10 | 8 | 6 | 4 |
| Bypass EGC/output EGC (AWG/kcmil) | 10 | 8 | 8 | 8 |
| Neutral (AWG/kcmil) | 6 | 4 | 2 | 1/0 |
| DC+/DC-(AWG/kcmil) ¹¹ | 6 | 4 | 2 | 1/0 |
| DC EGC (AWG/kcmil) | 8 | 6 | 6 | 6 |

NOTE: Cable sizes are based on 80% rated circuit breakers for UIB, UOB, MBB, SSIB, and 100% rated circuit breaker for battery breaker(s).

11. Values are based on 40 battery blocks.

Recommended Upstream Protection 480 V

⚡ ⚠ DANGER

HAZARD OF ELECTRIC SHOCK, EXPLOSION, OR ARC FLASH

For parallel systems, instantaneous override (Ii) values must not be set higher than 800 A. Place the label 885-92557 adjacent to the upstream circuit breaker to inform about the hazard.

Failure to follow these instructions will result in death or serious injury.

⚠ CAUTION

HAZARD OF FIRE

- Connect only to a circuit with the below specifications.
- Connect to a circuit provided with a 125 A branch circuit overcurrent protection maximum in accordance with the National Electrical Code, ANSI/NFPA70, and the Canadian Electrical Code, Part I, C22.1.

Failure to follow these instructions can result in injury or equipment damage.

NOTE: Overcurrent protection is to be provided by others and marked with its function.

| UPS rating | 20 kW | | 30 kW | | 40 kW | | 50 kW | |
|------------------------------------|--------------|--------|-------|--------|-------|--------|-------|--------|
| | Input | Bypass | Input | Bypass | Input | Bypass | Input | Bypass |
| Breaker type | HJF36100U31X | | | | | | | |
| I _r (A) | 40 | 35 | 60 | 50 | 80 | 70 | 100 | 80 |
| tr @ 6 I _r | 0.5 | | | | | | | |
| I _i (x I _n) | 1.5 | | | | | | | |

Specifications for 208 V Systems

Input Specifications 208 V

| UPS rating | 10 kW | 15 kW | 20 kW | 25 kW |
|----------------------------------|---|--------------------|--------------------|--------------------|
| Voltage (V) | 200/208/220 | 200/208/220 | 200/208/220 | 200/208/220 |
| Connections | 4-wire (L1, L2, L3, N, G) WYE (single mains) 3-wire (L1, L2, L3, G) WYE (dual mains) | | | |
| Input voltage range (V) | 200 V: 170-230 208 V: 177-239 220 V: 187-253 | | | |
| Frequency range (Hz) | 40-70 | | | |
| Nominal input current (A) | 31/30/28 | 47/45/42 | 62/60/56 | 78/75/71 |
| Maximum input current (A) | 37/36/34 | 56/54/51 | 74/72/68 | 91/90/85 |
| Input current limitation (A) | 39/37/35 | 58/55/52 | 77/74/70 | 91/91/87 |
| Input power factor | 0.99 for load greater than 50% 0.95 for load greater than 25% | | | |
| Total harmonic distortion (THDI) | <3% at full linear load (symmetrical) | | | |
| Maximum short circuit rating | 65 kA RMS | | | |
| Protection | Built-in backfeed protection and fuses | | | |
| Ramp-in | Programmable and adaptive 1-40 seconds | | | |

Bypass Specifications 208 V

| UPS rating | 10 kW | 15 kW | 20 kW | 25 kW |
|--|---|--------------------|--------------------|--------------------|
| Voltage (V) | 200/208/220 | 200/208/220 | 200/208/220 | 200/208/220 |
| Connections | 4-wire (L1, L2, L3, N, G) WYE | | | |
| Bypass voltage range (V) | 200 V: 180-220 208 V: 187-229 220 V: 198-242 | | | |
| Frequency range (Hz) | 50/60 ± 1, 50/60 ± 3, 50/60 ± 10 (user selectable) | | | |
| Nominal bypass current (A) | 29/28/27 | 44/42/40 | 58/56/53 | 73/70/66 |
| Nominal neutral current (A) | 50/48/45 | 75/72/68 | 100/96/91 | 125/120/114 |
| Maximum short circuit rating ¹² | 65 kA RMS | | | |
| Protection | Built-in backfeed protection and fuses Internal fuse specifications: Rated 200 A, prearcing 5.25 kA ² s | | | |

12. Conditioned by the internal fuse rated 200 A, prearcing 5.25 kA²s.

Output Specifications 208 V

| UPS rating | 10 kW | 15 kW | 20 kW | 25 kW |
|----------------------------------|---|-------------|-------------|-------------|
| Voltage (V) | 200/208/220 | 200/208/220 | 200/208/220 | 200/208/220 |
| Connections | 4-wire (L1, L2, L3, N, G) | | | |
| Voltage regulation | Symmetrical load $\pm 1\%$ Asymmetrical load $\pm 3\%$ | | | |
| Overload capacity | 150% for 1 minute (in normal operation) 125% for 10 minutes (in normal operation) 125% for 1 minute (in battery operation) 125% continuous (bypass operation) 1000% for 100 milliseconds (bypass operation) | | | |
| Dynamic load response | $\pm 5\%$ after 2 milliseconds $\pm 1\%$ after 50 milliseconds | | | |
| Output power factor | 1 | | | |
| Nominal output current (A) | 29/28/26 | 43/42/39 | 58/56/52 | 73/70/66 |
| Frequency regulation (Hz) | 50/60 Hz bypass synchronized – 50/60 Hz $\pm 0.1\%$ free-running | | | |
| Synchronized slew rate (Hz/sec) | Programmable to 0.25, 0.5, 1, 2, 4, 6 | | | |
| Total harmonic distortion (THDU) | <2% for linear load <5% for non-linear load | | | |
| Load crest factor | 2.5 | | | |
| Load power factor | From 0.7 leading to 0.7 lagging without any derating | | | |

Battery Specifications 208 V

⚡⚡ DANGER

HAZARD OF ELECTRIC SHOCK, EXPLOSION, OR ARC FLASH

Protection of the energy storage device: An overcurrent protective device must be located in close proximity to the energy storage device.

Failure to follow these instructions will result in death or serious injury.

All values are based on 40 battery blocks.

| UPS rating | 10 kW | 15 kW | 20 kW | 25 kW |
|--|--|-------|-------|-------|
| Charging power in % of output power at 0-40% load | 80% | | | |
| Charging power in % of output power at 100% load | 20% | | | |
| Maximum charging power (at 0-40% load) (kW) | 8 | 12 | 16 | 20 |
| Maximum charging power (at 100% load) (kW) | 2 | 3 | 4 | 5 |
| Nominal battery voltage (VDC) | 480 | | | |
| Nominal float voltage (VDC) | 545 | | | |
| Maximum boost voltage (VDC) | 571 | | | |
| Temperature compensation (per cell) | -3.3mV/°C, for T ≥ 25 °C – 0mV/°C, for T < 25 °C | | | |
| End of discharge voltage (full load) (VDC) | 384 | | | |
| Battery current at full load and nominal battery voltage (A) | 22 | 33 | 44 | 55 |
| Battery current at full load and minimum battery voltage (A) | 27 | 41 | 54 | 68 |
| Ripple current | < 5% C20 (5 minute runtime) | | | |
| Battery test | Manual/automatic (selectable) | | | |
| Maximum short circuit rating | 10 kA | | | |

Recommended Cable Sizes 208 V

⚡⚠ DANGER

HAZARD OF ELECTRIC SHOCK, EXPLOSION, OR ARC FLASH

All wiring must comply with all applicable national and/or electrical codes. The maximum allowable cable size is 1/0 AWG.

Failure to follow these instructions will result in death or serious injury.

The maximum number of cable connections per busbar: 2 on input/output/bypass busbars; 2 on DC+/DC- busbars; 4 on N busbar; 5 on G busbar.

NOTE: Overcurrent protection is to be provided by others.

Cable sizes in this manual are based on Table 310.15 (B)(16) of the National Electrical Code (NEC) with the following assertions:

- 90 °C (194 °F) conductors (75 °C (167 °F) termination)
- An ambient temperature of 30 °C (86 °F)
- Use of copper conductors

If the ambient temperature is greater than 30 °C (86 °F), larger conductors are to be selected in accordance with the correction factors of the NEC.

Equipment grounding conductors (EGC) are sized in accordance with NEC Article 250.122 and Table 250.122.

NOTE: Recommended cable sizes and maximum allowable cable size may vary for the auxiliary products. Not all auxiliary products support aluminum cables. Refer to the installation manual provided with the auxiliary product.

NOTE: The DC cable sizes given here are recommendations – Always follow the specific instructions in the battery solution documentation for DC cable sizes and DC EGC cable sizes and ensure that the DC cable sizes match the battery breaker rating.

NOTE: Neutral conductor is sized to handle 1.73 times phase current in case of high harmonic content from non-linear loads. If non or less harmonic currents are expected, neutral conductor can be sized accordingly but not less than the phase conductor.

Copper

| UPS rating | 10 kW | 15 kW | 20 kW | 25 kW |
|-----------------------------------|-------|-------|-------|---------|
| Input phases (AWG/kcmil) | 8 | 4 | 3 | 2 |
| Input EGC (AWG/kcmil) | 8 | 8 | 8 | 6 |
| Bypass/output phases (AWG/kcmil) | 8 | 6 | 4 | 3 |
| Bypass EGC/output EGC (AWG/kcmil) | 8 | 8 | 8 | 8 |
| Neutral (AWG/kcmil) | 6 | 3 | 1 | 2 x 1/0 |
| DC+/DC-(AWG/kcmil) ¹³ | 10 | 8 | 6 | 4 |
| DC EGC (AWG/kcmil) | 10 | 10 | 8 | 8 |

NOTE: Cable sizes are based on 80% rated circuit breakers for UIB, UOB, MBB, SSIB, and 100% rated circuit breaker for battery breaker(s).

13. Values are based on 40 battery blocks.

Recommended Upstream Protection 208 V

⚡⚡ DANGER

HAZARD OF ELECTRIC SHOCK, EXPLOSION, OR ARC FLASH

For parallel systems, instantaneous override (Ii) values must not be set higher than 800 A. Place the label 885-92557 adjacent to the upstream circuit breaker to inform about the hazard.

Failure to follow these instructions will result in death or serious injury.

⚠ CAUTION

HAZARD OF FIRE

- Connect only to a circuit with the below specifications.
- Connect to a circuit provided with a 125 A branch circuit overcurrent protection maximum in accordance with the National Electrical Code, ANSI/NFPA70, and the Canadian Electrical Code, Part I, C22.1.

Failure to follow these instructions can result in injury or equipment damage.

NOTE: Overcurrent protection is to be provided by others and marked with its function.

| UPS rating | 10 kW | | 15 kW | | 20 kW | | 25 kW | |
|------------------------------------|--------------|--------|-------|--------|-------|--------|---------------|---------------|
| | Input | Bypass | Input | Bypass | Input | Bypass | Input | Bypass |
| Breaker type | HJF36100U31X | | | | | | HJF36150-U31X | HJF36100-U31X |
| I _r (A) | 50 | 40 | 80 | 60 | 100 | 80 | 125 | 100 |
| t _r @ 6 I _r | 0.5 | | | | | | | |
| I _i (x I _n) | 1.5 | | | | | | | |

Recommended Bolt and Lug Sizes

NOTICE

RISK OF EQUIPMENT DAMAGE

Use only UL approved compression cable lugs.

Failure to follow these instructions can result in equipment damage.

Copper

| Cable size | Bolt size | Cable lug type | Crimping tool | Die |
|------------|------------|----------------|---------------|---------------------|
| 10 AWG | M6 x 20 mm | LCA10-14-L | CT-1570 | NA |
| 8 AWG | M6 x 20 mm | LCA8-14-L | CT-720 | CD-720-1 Red P21 |
| 6 AWG | M6 x 20 mm | LCA6-14-L | CT-720 | CD-720-1 Blue P24 |
| 4 AWG | M6 x 20 mm | LCA4-14-L | CT-720 | CD-720-1 Gray P29 |
| 3 AWG | M6 x 20 mm | LCA4-14-L | CT-720 | CD-720-1 Gray P29 |
| 2 AWG | M6 x 20 mm | LCA4-14-L | CT-720 | CD-720-1 Brown P33 |
| 1 AWG | M6 x 20 mm | LCA1-14-E | CT-720 | CD-720-2 Green P37 |
| 1/0 AWG | M6 x 20 mm | LCA1/0-14-X | CT-720 | CD-720-2 Pink P42 |
| 2/0 AWG | M6 x 20 mm | LCA2/0-14-X | CT-720 | CD-720-2 Black P45 |
| 3/0 AWG | M6 x 20 mm | LCA3/0-14-X | CT-720 | CD-720-2 Orange P50 |
| 4/0 AWG | M6 x 20 mm | LCA4/0-14-X | CT-720 | CD-720-3 Purple P54 |

Torque Specifications

| Bolt size | Torque |
|-----------|-------------------------------------|
| M4 | 1.7 Nm (1.25 lb-ft / 15 lb-in) |
| M5 | 2.2 Nm (1.62 lb-ft / 19.5 lb-in) |
| M6 | 5 Nm (3.69 lb-ft / 44.3 lb-in) |
| M8 | 17.5 Nm (12.91 lb-ft / 154.9 lb-in) |
| M10 | 30 Nm (22 lb-ft / 194.7 lb-in) |
| M12 | 50 Nm (36.87 lb-ft / 442.5 lb-in) |

Environment

| | Operating | Storage |
|--|---|--|
| Temperature | 0 °C to 40 °C (32 °F to 104 °F) | -15 °C to 40 °C (5 °F to 104 °F) for systems with batteries. |
| Relative humidity | 0 - 95% non-condensing | 10 - 80% non-condensing |
| Elevation | Designed for operation in 0-3000 m (0-10000 feet) elevation. Power derating required from 1000-3000 m (3300-10000 feet): Up to 1000 m (3300 feet): 1.000 Up to 1500 m (5000 feet): 0.975 Up to 2000 m (6600 feet): 0.950 Up to 2500 m (8300 feet): 0.925 Up to 3000 m (10000 feet): 0.900 | |
| Audible noise one meter (three feet) from unit | 480 V 20 kW and 208 V 10 kW: 49 dB at 70% load, 55 dB at 100% load 480 V 30-50 kW and 208 V 15-25 kW: 54 dB at 70% load, 61 dB at 100% load | |
| Protection class | IP20 | |
| Color | RAL 9003, gloss level 85% | |

Heat Dissipation in BTU/hr

480 V UPS

Normal Operation

| UPS rating | 20 kW | 30 kW | 40 kW | 50 kW |
|------------|-------|-------|-------|-------|
| 25% load | 913 | 1441 | 1705 | 1865 |
| 50% load | 1282 | 1995 | 2394 | 2754 |
| 75% load | 1692 | 2581 | 3175 | 3883 |
| 100% load | 2198 | 3175 | 4086 | 5210 |

ECO Mode

| UPS rating | 20 kW | 30 kW | 40 kW | 50 kW |
|------------|-------|-------|-------|-------|
| 25% load | 515 | 596 | 636 | 704 |
| 50% load | 597 | 745 | 802 | 926 |
| 75% load | 664 | 845 | 1015 | 1121 |
| 100% load | 752 | 1015 | 1184 | 1402 |

eConversion

| UPS rating | 20 kW | 30 kW | 40 kW | 50 kW |
|------------|-------|-------|-------|-------|
| 25% load | 615 | 967 | 996 | 1018 |
| 50% load | 678 | 1054 | 1147 | 1206 |
| 75% load | 752 | 1198 | 1316 | 1383 |
| 100% load | 831 | 1316 | 1434 | 1625 |

Battery Operation

| UPS rating | 20 kW | 30 kW | 40 kW | 50 kW |
|------------|-------|-------|-------|-------|
| 25% load | 1188 | 2514 | 2592 | 2690 |
| 50% load | 1554 | 2809 | 3109 | 3491 |

Battery Operation (Continued)

| UPS rating | 20 kW | 30 kW | 40 kW | 50 kW |
|------------|-------|-------|-------|-------|
| 75% load | 2043 | 3290 | 3956 | 4808 |
| 100% load | 2655 | 3956 | 5133 | 6641 |

208 V UPS

| 10 kW | Normal operation | | | ECO mode | | |
|-------------|------------------|------|------|----------|-----|-----|
| Voltage (V) | 200 | 208 | 220 | 200 | 208 | 220 |
| 25% load | 616 | 730 | 707 | 498 | 515 | 496 |
| 50% load | 983 | 1095 | 1050 | 590 | 566 | 571 |
| 75% load | 1484 | 1613 | 1510 | 670 | 659 | 640 |
| 100% load | 2132 | 2286 | 2112 | 753 | 746 | 725 |

| 10 kW | eConversion | | | Battery operation | | |
|-------------|-------------|-----|-----|-------------------|------|------|
| Voltage (V) | 200 | 208 | 220 | 200 | 208 | 220 |
| 25% load | 508 | 520 | 510 | 1021 | 891 | 990 |
| 50% load | 588 | 569 | 577 | 1228 | 1147 | 1164 |
| 75% load | 667 | 656 | 648 | 1562 | 1482 | 1448 |
| 100% load | 757 | 743 | 725 | 2024 | 1897 | 1840 |

| 15 kW | Normal operation | | | ECO mode | | |
|-------------|------------------|------|------|----------|------|-----|
| Voltage (V) | 200 | 208 | 220 | 200 | 208 | 220 |
| 25% load | 1148 | 1073 | 1110 | 614 | 615 | 599 |
| 50% load | 1687 | 1593 | 1562 | 726 | 723 | 706 |
| 75% load | 2381 | 2237 | 2178 | 892 | 888 | 872 |
| 100% load | 3209 | 2955 | 2853 | 1045 | 1039 | 970 |

| 15 kW | eConversion | | | Battery operation | | |
|-------------|-------------|------|------|-------------------|------|------|
| Voltage (V) | 200 | 208 | 220 | 200 | 208 | 220 |
| 25% load | 702 | 710 | 699 | 1727 | 1777 | 1762 |
| 50% load | 813 | 802 | 805 | 2016 | 2004 | 1939 |
| 75% load | 924 | 911 | 929 | 2403 | 2343 | 2226 |
| 100% load | 1072 | 1050 | 1031 | 2887 | 2792 | 2624 |

| 20 kW | Normal operation | | | ECO mode | | |
|-------------|------------------|------|------|----------|------|------|
| Voltage (V) | 200 | 208 | 220 | 200 | 208 | 220 |
| 25% load | 1338 | 1218 | 1232 | 635 | 651 | 663 |
| 50% load | 2143 | 1989 | 1924 | 822 | 795 | 771 |
| 75% load | 3209 | 2955 | 2853 | 1045 | 1039 | 970 |
| 100% load | 4596 | 4116 | 3995 | 1286 | 1244 | 1187 |

| 20 kW | eConversion | | | Battery operation | | |
|-------------|-------------|-----|-----|-------------------|------|------|
| Voltage (V) | 200 | 208 | 220 | 200 | 208 | 220 |
| 25% load | 735 | 733 | 744 | 1812 | 1840 | 1809 |
| 50% load | 868 | 882 | 891 | 2263 | 2218 | 2118 |

| 20 kW | eConversion | | | Battery operation | | |
|-------------|-------------|------|------|-------------------|------|------|
| Voltage (V) | 200 | 208 | 220 | 200 | 208 | 220 |
| 75% load | 1072 | 1050 | 1031 | 2887 | 2792 | 2624 |
| 100% load | 1282 | 1253 | 1221 | 3686 | 3564 | 3327 |

| 25 kW | Normal operation | | | ECO mode | | |
|-------------|------------------|------|------|----------|------|------|
| Voltage (V) | 200 | 208 | 220 | 200 | 208 | 220 |
| 25% load | 1495 | 1400 | 1405 | 675 | 689 | 681 |
| 50% load | 2636 | 2476 | 2387 | 942 | 933 | 902 |
| 75% load | 4222 | 3799 | 3673 | 1226 | 1186 | 1133 |
| 100% load | 6322 | 5894 | 5406 | 1564 | 1502 | 1422 |

| 25 kW | eConversion | | | Battery operation | | |
|-------------|-------------|------|------|-------------------|------|------|
| Voltage (V) | 200 | 208 | 220 | 200 | 208 | 220 |
| 25% load | 725 | 769 | 755 | 1908 | 1916 | 1868 |
| 50% load | 968 | 972 | 956 | 2553 | 2481 | 2346 |
| 75% load | 1231 | 1200 | 1169 | 3470 | 3353 | 3133 |
| 100% load | 1530 | 1487 | 1526 | 4658 | 4533 | 4227 |

Heat Dissipation for Maintenance Bypass Cabinet with Transformer in BTU/hr

| | Maintenance bypass cabinet with input transformer | Maintenance bypass cabinet with output transformer |
|----------------------|---|--|
| Commercial reference | GVSBPIT25B | GVSBPOT50B |
| 100% load | 2700 | 5300 |

UPS Shipping Weights and Dimensions

| | Weight kg (lbs) | Height mm (in) | Width mm (in) | Depth mm (in) |
|--|-----------------|----------------|---------------|---------------|
| 20-50 kW UPS 480 V without preinstalled battery strings* | 200 (441) | 1680 (66.14) | 640 (25.2) | 990 (38.98) |
| 20 kW 480 V UPS with one battery string | 350 (772) | 1680 (66.14) | 640 (25.2) | 990 (38.98) |
| 30-50 kW 480 V UPS with two battery strings | 490 (1080) | 1680 (66.14) | 640 (25.2) | 990 (38.98) |
| 10-25 kW UPS 208 V without preinstalled battery strings* | 200 (441) | 1680 (66.14) | 640 (25.2) | 990 (38.98) |
| 10 kW 208 V UPS with one battery string | 350 (772) | 1680 (66.14) | 640 (25.2) | 990 (38.98) |
| 15-25 kW 208 V UPS with two battery strings | 490 (1080) | 1680 (66.14) | 640 (25.2) | 990 (38.98) |

NOTE: The UPS models marked with an * in the table above are shipped with no power modules preinstalled in the UPS and all power modules shipped separately. Battery strings are not included and must be bought separately.

Power Module Shipping Weights and Dimensions

| Commercial reference | Weight kg (lbs) | Height mm (in) | Width mm (in) | Depth mm (in) |
|----------------------|-----------------|----------------|---------------|---------------|
| GVPM20KD | 48 (106) | 330 (12.99) | 580 (22.83) | 780 (30.70) |
| GVPM50KD | 62 (137) | 330 (12.99) | 580 (22.83) | 780 (30.70) |

Modular Battery Shipping Weights and Dimensions

| Commercial reference | Weight kg (lbs) | Height mm (in) | Width mm (in) | Depth mm (in) |
|----------------------|-----------------|----------------|---------------|---------------|
| GVSPTHU | 33 (73) | 180 (7.08) | 150 (5.90) | 800 (31.49) |
| GVSPTHULL | 33 (73) | 180 (7.08) | 150 (5.90) | 800 (31.49) |

UPS Weights and Dimensions

| | Weight kg (lbs) | Height mm (in) | Width mm (in) | Depth mm (in) |
|---|-----------------|----------------|---------------|---------------|
| 20 kW 480 V UPS with one battery string | 320 (705) | 1485 (58.46) | 521 (20.51) | 847 (33.35) |
| 30-50 kW 480 V UPS with two battery strings | 460 (1014) | 1485 (58.46) | 521 (20.51) | 847 (33.35) |
| 10 kW 208 V UPS with one battery string | 320 (705) | 1485 (58.46) | 521 (20.51) | 847 (33.35) |
| 15-25 kW 208 V UPS with two battery strings | 460 (1014) | 1485 (58.46) | 521 (20.51) | 847 (33.35) |

NOTE: One battery module weighs approximately 32 kg (70.5 lbs). One battery string consists of four battery modules.

Clearance

NOTE: Clearance dimensions are published for airflow and service access only. Consult with the local safety codes and standards for additional requirements in your local area.

NOTE: The required minimum rear clearance is 150 mm (5.91 in).

Front View of the UPS

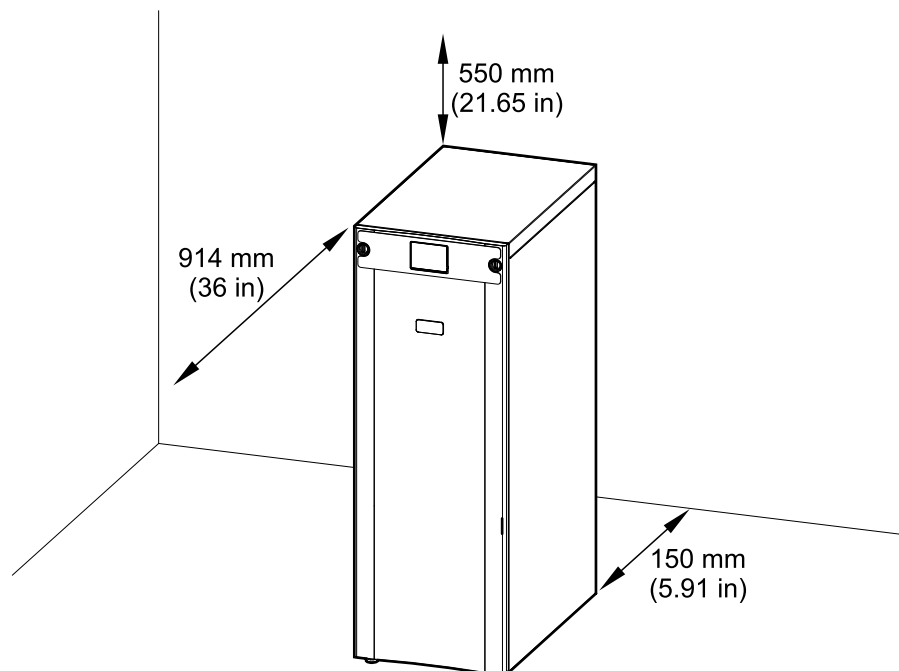

Drawings

NOTE: A comprehensive set of drawings is available on www.se.com.

NOTE: These drawings are for reference ONLY – subject to change without notice.

10-50 kW 480 V and 10-25 kW 208 V UPS

SINGLE MAINS (ADJACENT BATTERY)

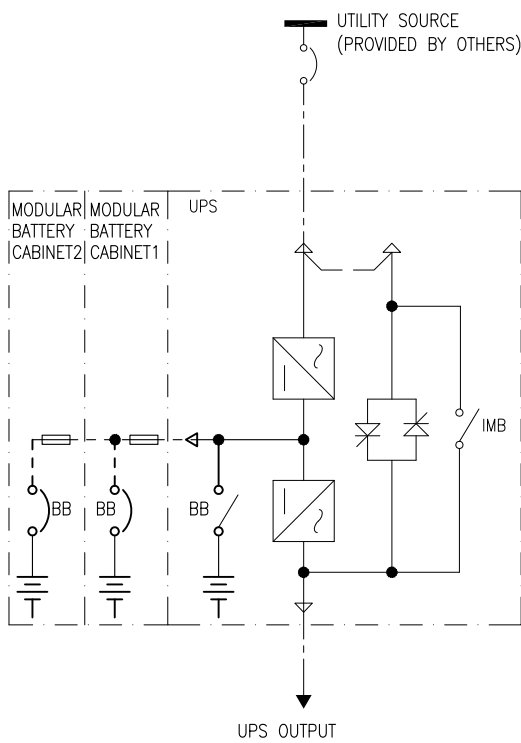

DUAL MAINS (ADJACENT BATTERY)

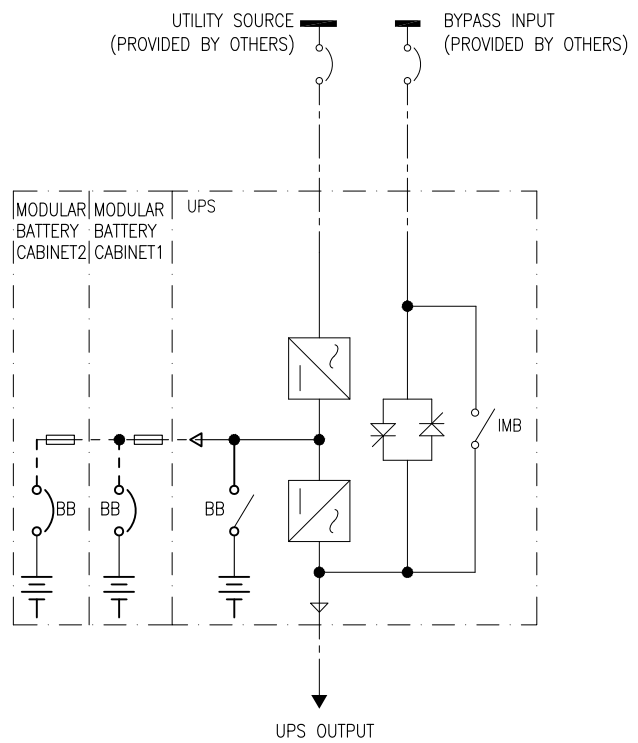

REMOTE BATTERY—TYPICAL
(REST OF CONNECTIONS
SIMILAR TO ADJACENT BATTERY
EXCEPT BELOW)

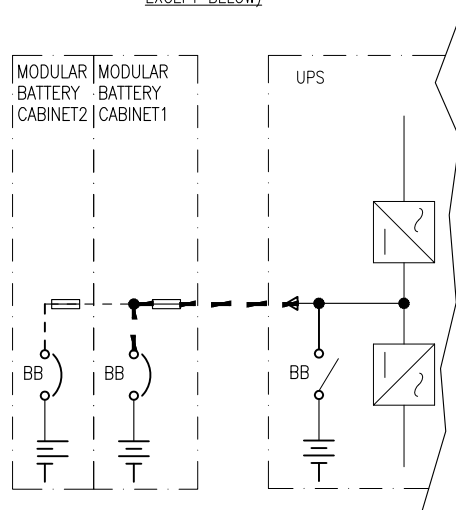

Options

Configuration Options

- eConversion mode
- Compact design, high density technology, and modular architecture
- Internal battery modules
- Single or dual mains
- Up to 4+0 UPSs in parallel for capacity
- Up to 3+1 UPSs in parallel for redundancy
- Rear cable entry
- EcoStruxure IT compatible
- Generator compatible
- Touchscreen LCD
- Replacement of power module in any operation mode (Live Swap)¹⁴
- ECO mode

14. In all systems configured for Live Swap.

Hardware Options

See Weights and Dimensions for Options, page 135.

NOTE: All hardware options listed here may not be available in all regions.

Power Module

- Power module 50 kW 480 V/25 kW 208 V (GVPM50KD)
- Power module 20 kW 480 V/10 kW 208 V (GVPM20KD)

Modular Battery Cabinet

Modular battery cabinet including battery breaker.

- Modular battery cabinet for up to six smart modular battery strings (GVSMODBC6)
- Modular battery cabinet for up to nine smart modular battery strings (GVSMODBC9)

Maintenance Bypass Cabinet

Maintenance bypass cabinet for complete isolation of the UPS during service operations. Only for single UPS.

- 10-40 kW 208 V, 20-80 kW 480 V maintenance bypass cabinet (GVSBPSU80G)

Maintenance Bypass Cabinet with Input Transformer

Maintenance bypass cabinet with input transformer for complete isolation of the UPS during service operations. Only for single 208 V UPS.

- 10-25 kW 480 V or 600 V in, 208 V out, maintenance bypass cabinet with input transformer (GVSBPIT25B)

Maintenance Bypass Cabinet with Output Transformer

Maintenance bypass cabinet with output transformer for complete isolation of the UPS during service operations. Only for single 480 V UPS.

- 20-50 kW 480 V in, 208 V out, maintenance bypass cabinet with output transformer (GVSBPOT50B)

Maintenance Bypass Panel

Maintenance bypass panel for complete isolation of the UPS during service operations. Only for single UPS.

- 10-30 kW 208 V, 20-60 kW 480 V maintenance bypass panel (GVSBPSU60G-WP)

Remote Alarm Panel

- Remote alarm panel (GVSOPT036)

Optional Installation Kits

- Seismic kit for UPS (GVSOPT002)
- Parallel kit for UPS (GVSOPT006)
- Live Swap kit for the UPS (GVSOPT039)

Optional Network Management Card

- Network Management Card LCES2 with Modbus, Ethernet and AUX sensors (AP9644)

Air Filter

- Air filter kit (GVSOPT001)

Battery Modules

9 Ah smart high capacity battery modules. This battery module type is delivered for UPS models with preinstalled battery strings.

- Galaxy VS 9 Ah Smart High Capacity Battery Module (GVSBTU)
- Galaxy VS 9 Ah Smart Modular High Capacity Battery String (GVSBT4)

9 Ah smart long-life high capacity battery modules. For this battery module type, select a UPS models without preinstalled battery strings.

- Galaxy VS 9 Ah Smart Long-Life High Capacity Battery Module (GVSBTULL)
- Galaxy VS 9 Ah Smart Modular Long-Life High Capacity Battery String (GVSBT4LL)

NOTE: Always use the same battery module type in the UPS system. Do not mix different battery module types.

UPS with Internal Batteries Up to 5 Battery Strings

Single System Overview

| | |
|------|---|
| UIB | Unit input breaker |
| SSIB | Static switch input breaker |
| IMB | Internal maintenance breaker |
| UOB | Unit output breaker |
| BB | Battery breaker in UPS for internal batteries and in external battery solution (if present) |

Single System – Single Mains

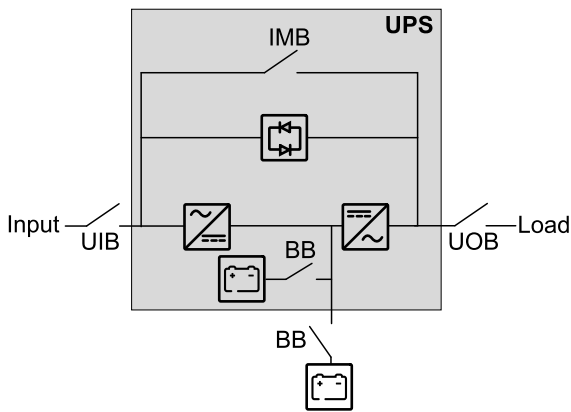

Single System – Dual Mains

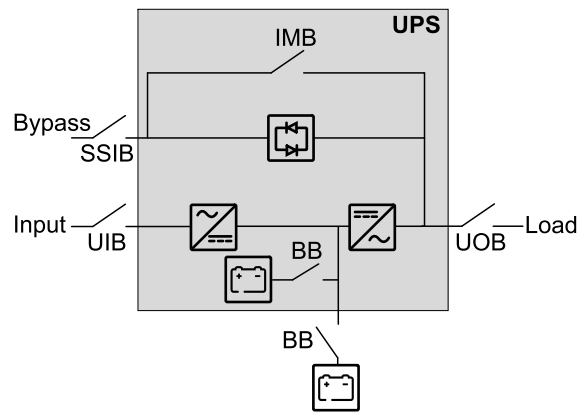

Parallel System Overview

| | |
|------|---|
| UIB | Unit input breaker |
| SSIB | Static switch input breaker |
| IMB | Internal maintenance breaker |
| UOB | Unit output breaker |
| SIB | System isolation breaker |
| BB | Battery breaker in UPS for internal batteries and in external battery solution (if present) |
| MBB | External maintenance bypass breaker |

Simplified 1+1 Parallel Systems

Galaxy VS can support 2 UPSs in a simplified 1+1 parallel system for redundancy with shared unit input breaker UIB and static switch input breaker SSIB.

Simplified 1+1 Parallel System – Single Mains

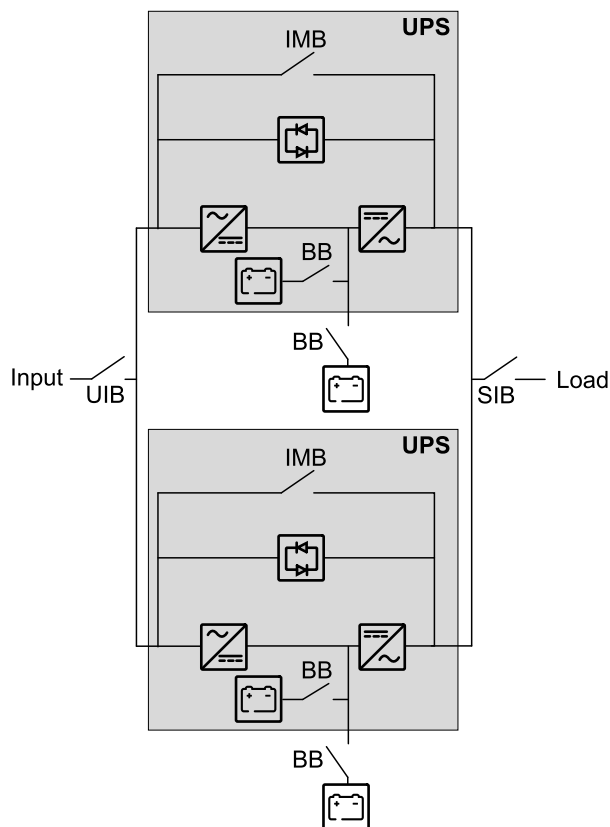

Simplified 1+1 Parallel System – Dual Mains

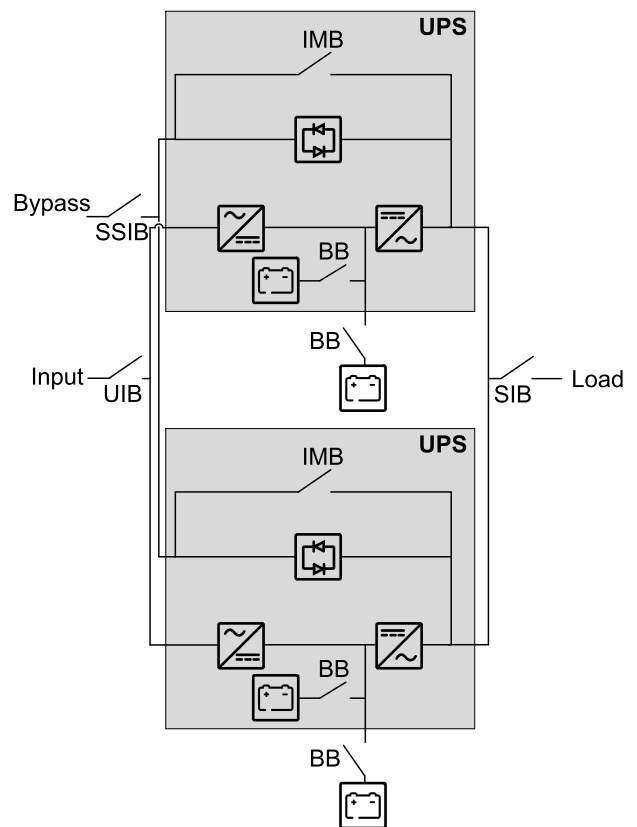

Parallel Systems with Individual Unit Input Breaker UIB and Static Switch Input Breaker SSIB

Galaxy VS can support up to 4 UPSs in parallel for capacity and up to 3+1 UPSs in parallel for redundancy with individual unit input breaker UIB and static switch input breaker SSIB.

NOTE: The internal maintenance breaker IMB can only be used in a simplified 1+1 parallel system. In any other parallel system, an external maintenance bypass breaker MBB must be provided and the internal maintenance breaker IMB* must be padlocked in the open position.

Parallel System – Single Mains

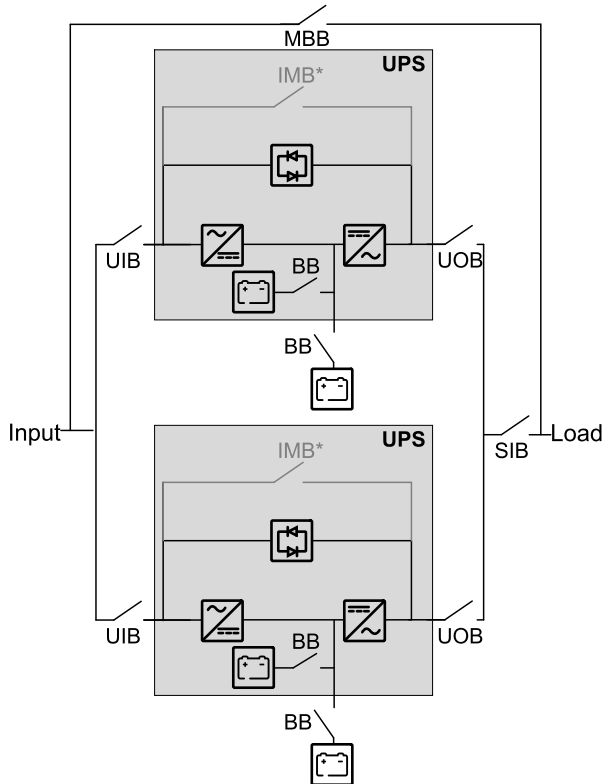

Parallel System – Dual Mains

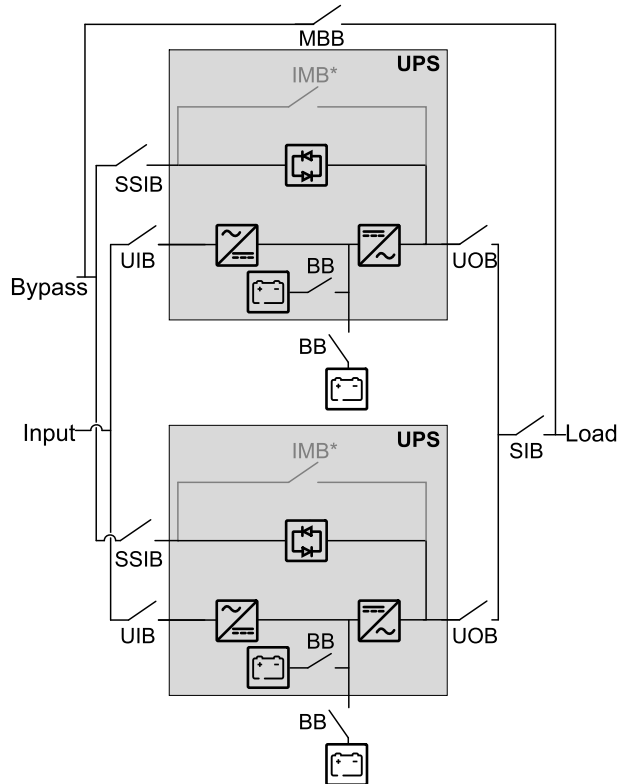

Parallel Systems with Shared Unit Input Breaker UIB and Static Switch Input Breaker SSIB

Galaxy VS can support up to 4 UPSs in parallel for capacity and up to 3+1 UPSs in parallel for redundancy with shared unit input breaker UIB and static switch input breaker SSIB.

NOTE: The internal maintenance breaker IMB can only be used in a simplified 1+1 parallel system. In any other parallel system, an external maintenance bypass breaker MBB must be provided and the internal maintenance breaker IMB* must be padlocked in the open position.

Parallel System – Single Mains

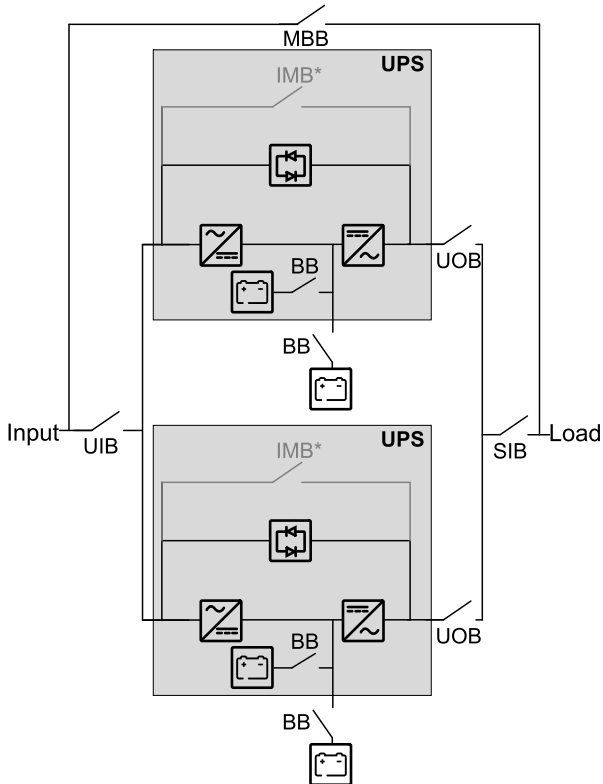

Parallel System – Dual Mains

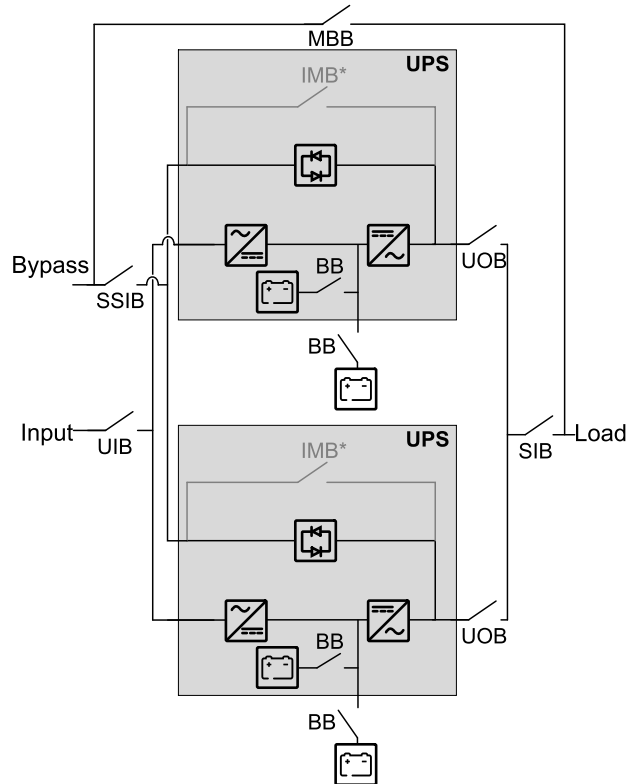

Input Voltage Window

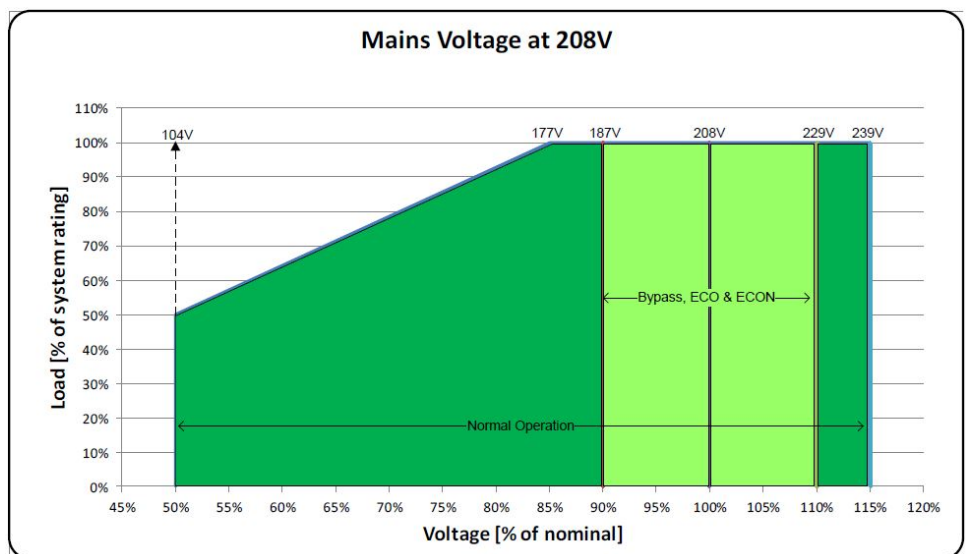
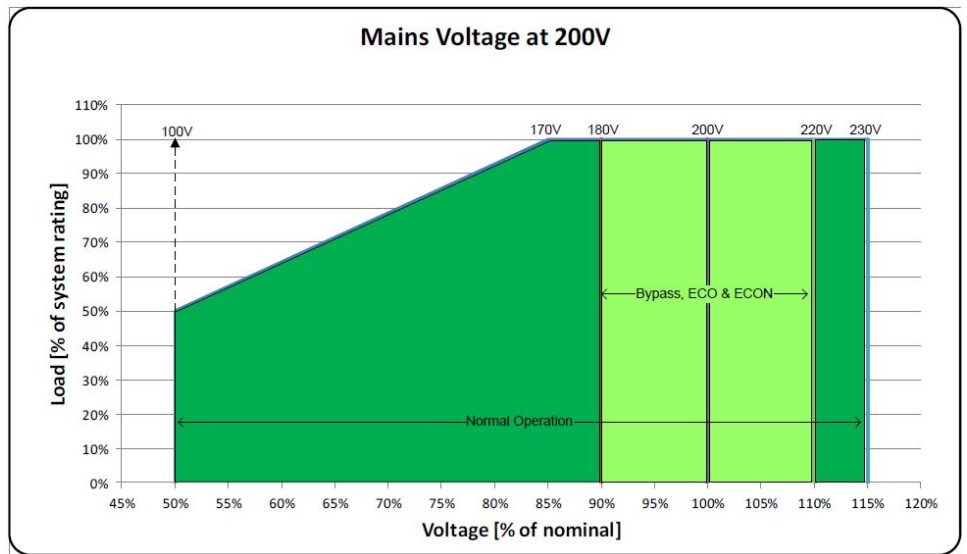
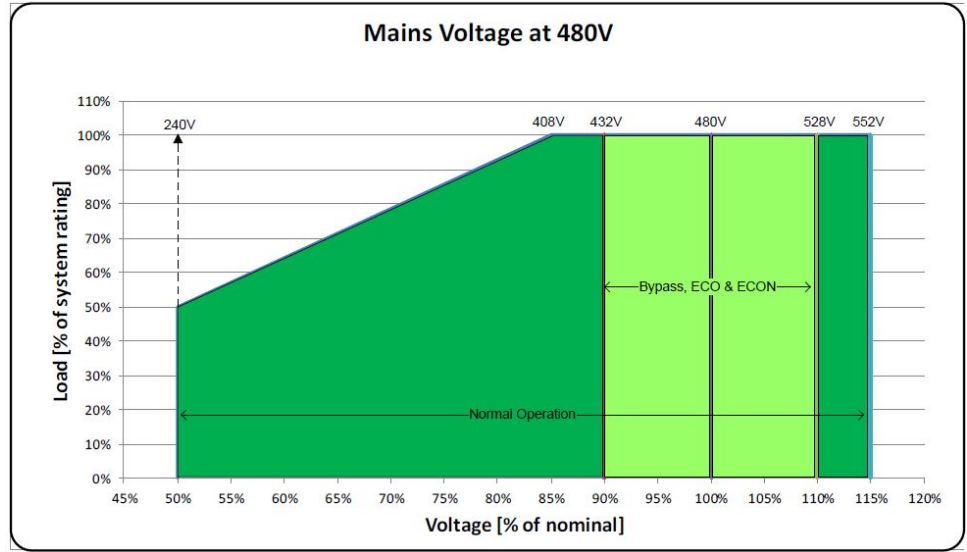

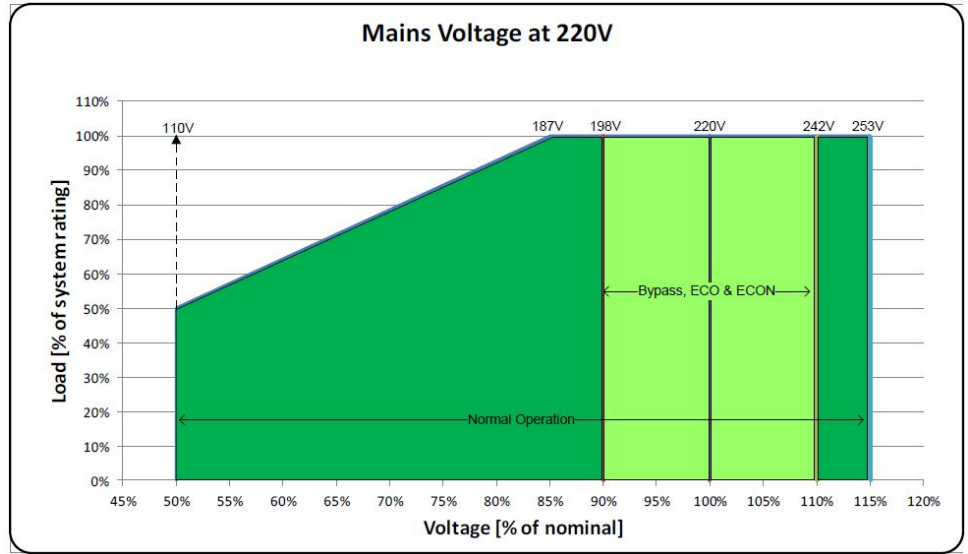

Inverter Short Circuit Capabilities (Bypass not Available)

IK1 – Short Circuit between a Phase and Neutral

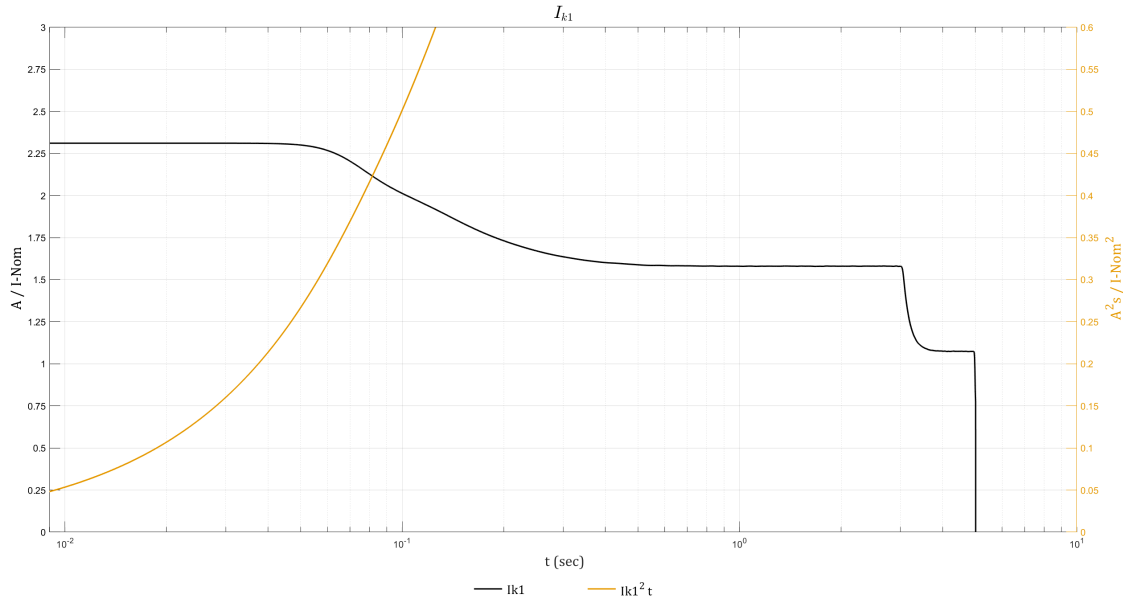

IK1 480 V

| S [kVA] | 10ms; I[A]/I ² t [A ² t] | 20ms; I[A]/I ² t [A ² t] | 30ms; I[A]/I ² t [A ² t] | 100ms; I[A]/I ² t [A ² t] | 1s; I[A]/I ² t [A ² t] |
|---------|--|--|--|---|--|
| 20 | 56 / 31 | 56 / 62 | 56 / 93 | 48 / 290 | 38 / 1674 |
| 30 | 83 / 70 | 83 / 140 | 83 / 210 | 73 / 650 | 57 / 3770 |
| 40 | 111 / 120 | 111 / 250 | 111 / 370 | 97 / 1160 | 76 / 6700 |
| 50 | 139 / 190 | 139 / 390 | 139 / 580 | 121 / 1810 | 95 / 10460 |
| 60 | 167 / 280 | 167 / 560 | 167 / 830 | 145 / 2610 | 114 / 15070 |
| 80 | 222 / 490 | 222 / 990 | 222 / 1480 | 194 / 4640 | 152 / 26790 |
| 100 | 278 / 770 | 278 / 1550 | 278 / 2320 | 242 / 7260 | 190 / 41860 |

IK1 208 V

| S [kVA] | 10ms; I[A]/I ² t [A ² t] | 20ms; I[A]/I ² t [A ² t] | 30ms; I[A]/I ² t [A ² t] | 100ms; I[A]/I ² t [A ² t] | 1s; I[A]/I ² t [A ² t] |
|---------|--|--|--|---|--|
| 10 | 64 / 41 | 64 / 82 | 64 / 123 | 56 / 386 | 44 / 2229 |
| 15 | 96 / 93 | 96 / 185 | 96 / 278 | 84 / 869 | 66 / 5015 |
| 20 | 128 / 160 | 128 / 330 | 128 / 490 | 112 / 1550 | 88 / 8920 |
| 25 | 160 / 260 | 160 / 510 | 160 / 770 | 140 / 2420 | 110 / 13930 |
| 30 | 192 / 370 | 192 / 740 | 192 / 1110 | 168 / 3480 | 132 / 20060 |
| 40 | 257 / 660 | 257 / 1320 | 257 / 1980 | 224 / 6180 | 175 / 35670 |
| 50 | 321 / 1030 | 321 / 2060 | 321 / 3090 | 279 / 9660 | 219 / 55730 |

IK2 – Short Circuit between Two Phases

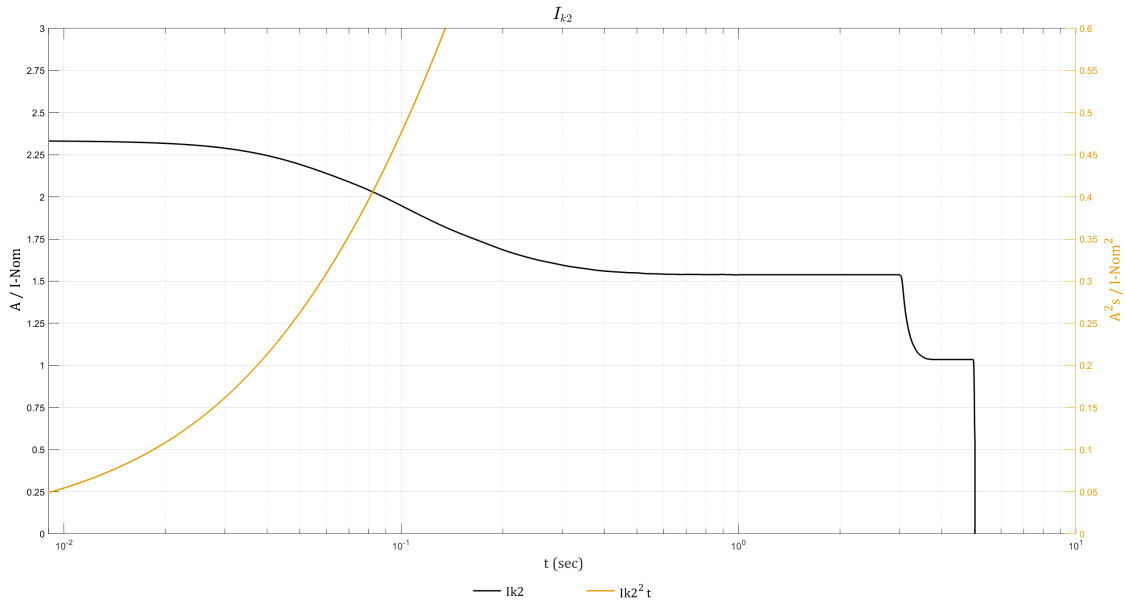

IK2 480 V

| S [kVA] | 10ms; I[A]/I²t [A²t] | 20ms; I[A]/I²t [A²t] | 30ms; I[A]/I²t [A²t] | 100ms; I[A]/I²t [A²t] | 1s; I[A]/I²t [A²t] |
|---------|----------------------|----------------------|----------------------|-----------------------|--------------------|
| 20 | 56 / 31 | 56 / 63 | 56 / 94 | 47 / 276 | 37 / 1586 |
| 30 | 84 / 70 | 84 / 140 | 84 / 210 | 70 / 620 | 55 / 3570 |
| 40 | 112 / 130 | 112 / 250 | 112 / 370 | 94 / 1100 | 74 / 6350 |
| 50 | 140 / 200 | 139 / 390 | 139 / 580 | 117 / 1720 | 92 / 9910 |
| 60 | 168 / 280 | 167 / 570 | 167 / 840 | 141 / 2480 | 111 / 14280 |
| 80 | 224 / 500 | 223 / 1000 | 223 / 1500 | 187 / 4410 | 148 / 25380 |
| 100 | 280 / 790 | 279 / 1570 | 279 / 2340 | 234 / 6890 | 185 / 39660 |

IK2 208 V

| S [kVA] | 10ms; I[A]/I²t [A²t] | 20ms; I[A]/I²t [A²t] | 30ms; I[A]/I²t [A²t] | 100ms; I[A]/I²t [A²t] | 1s; I[A]/I²t [A²t] |
|---------|----------------------|----------------------|----------------------|-----------------------|--------------------|
| 10 | 65 / 42 | 64 / 84 | 64 / 125 | 54 / 367 | 43 / 2112 |
| 15 | 97 / 94 | 96 / 188 | 96 / 280 | 81 / 825 | 64 / 4752 |
| 20 | 129 / 170 | 129 / 330 | 129 / 500 | 108 / 1470 | 85 / 8450 |
| 25 | 162 / 260 | 161 / 520 | 161 / 780 | 135 / 2290 | 107 / 13200 |
| 30 | 194 / 380 | 193 / 750 | 193 / 1120 | 162 / 3300 | 128 / 19010 |
| 40 | 259 / 670 | 257 / 1340 | 257 / 1990 | 216 / 5870 | 171 / 33790 |
| 50 | 323 / 1050 | 322 / 2090 | 322 / 3110 | 270 / 9170 | 213 / 52800 |

IK3 – Short Circuit between Three Phases

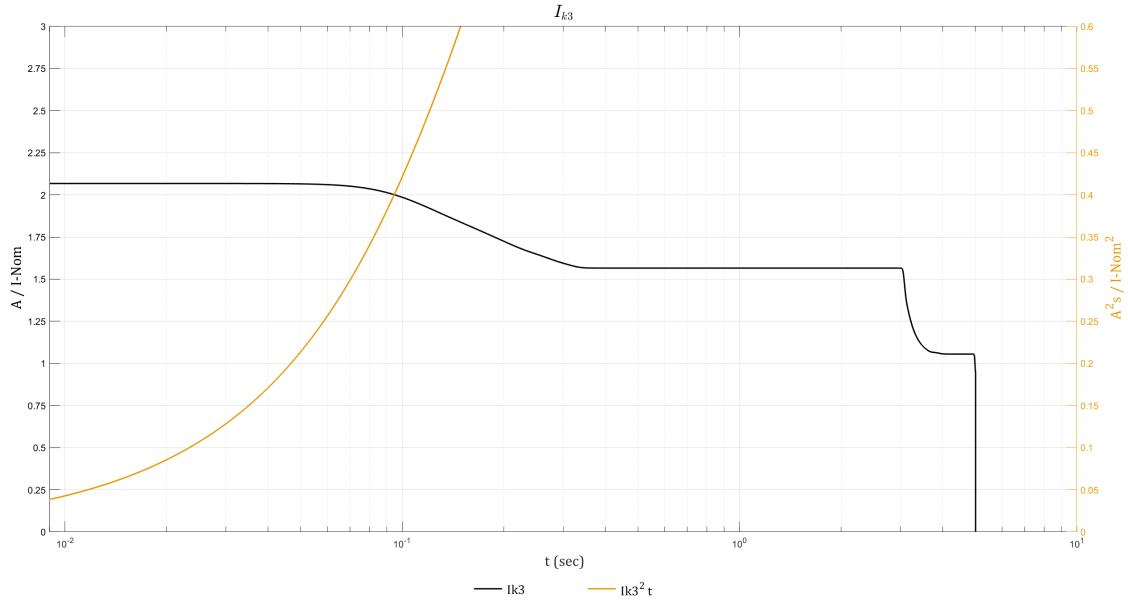

IK3 480 V

| S [kVA] | 10ms; I[A]/I ² t [A ² t] | 20ms; I[A]/I ² t [A ² t] | 30ms; I[A]/I ² t [A ² t] | 100ms; I[A]/I ² t [A ² t] | 1s; I[A]/I ² t [A ² t] |
|---------|--|--|--|---|--|
| 20 | 50 / 25 | 50 / 49 | 50 / 74 | 48 / 244 | 38 / 1593 |
| 30 | 75 / 60 | 75 / 110 | 75 / 170 | 72 / 550 | 57 / 3580 |
| 40 | 99 / 100 | 99 / 200 | 99 / 300 | 96 / 980 | 75 / 6370 |
| 50 | 124 / 150 | 124 / 310 | 124 / 460 | 119 / 1520 | 94 / 9960 |
| 60 | 149 / 220 | 149 / 450 | 149 / 670 | 143 / 2200 | 113 / 14340 |
| 80 | 199 / 400 | 199 / 790 | 199 / 1190 | 191 / 3900 | 151 / 25490 |
| 100 | 249 / 620 | 249 / 1240 | 249 / 1860 | 239 / 6100 | 188 / 39830 |

IK3 208 V

| S [kVA] | 10ms; I[A]/I ² t [A ² t] | 20ms; I[A]/I ² t [A ² t] | 30ms; I[A]/I ² t [A ² t] | 100ms; I[A]/I ² t [A ² t] | 1s; I[A]/I ² t [A ² t] |
|---------|--|--|--|---|--|
| 10 | 57 / 33 | 57 / 66 | 57 / 99 | 55 / 325 | 43 / 2121 |
| 15 | 86 / 74 | 86 / 148 | 86 / 222 | 83 / 731 | 65 / 4772 |
| 20 | 115 / 130 | 115 / 260 | 115 / 400 | 110 / 1300 | 87 / 8480 |
| 25 | 143 / 210 | 143 / 410 | 143 / 620 | 138 / 2030 | 109 / 13260 |
| 30 | 172 / 300 | 172 / 590 | 172 / 890 | 165 / 2920 | 130 / 19090 |
| 40 | 230 / 530 | 230 / 1050 | 230 / 1580 | 220 / 5200 | 174 / 33940 |
| 50 | 287 / 820 | 287 / 1650 | 287 / 2470 | 276 / 8120 | 217 / 53020 |

Efficiency

480 V UPS

Normal Operation

| UPS rating | 20 kW with N+1 power module | 30 kW with N+1 power module | 40 kW with N+1 power module | 50 kW with N+1 power module |
|------------|-----------------------------|-----------------------------|-----------------------------|-----------------------------|
| 25% load | 92.9% | 92.1% | 93.0% | 94.0% |
| 50% load | 95.3% | 94.7% | 95.4% | 95.8% |
| 75% load | 96.2% | 95.6% | 96.1% | 96.3% |
| 100% load | 96.6% | 96.1% | 96.4% | 96.5% |

Normal Operation

| UPS rating | 60 kW | 80 kW | 100 kW |
|------------|-------|-------|--------|
| 25% load | 95.3% | 95.3% | 95.7% |
| 50% load | 96.3% | 96.4% | 96.6% |
| 75% load | 96.5% | 96.7% | 96.7% |
| 100% load | 96.5% | 96.7% | 96.6% |

ECO Mode

| UPS rating | 20 kW with N+1 power module | 30 kW with N+1 power module | 40 kW with N+1 power module | 50 kW with N+1 power module |
|------------|-----------------------------|-----------------------------|-----------------------------|-----------------------------|
| 25% load | 95.6% | 96.4% | 97.0% | 97.6% |
| 50% load | 97.6% | 98.0% | 98.3% | 98.6% |
| 75% load | 98.2% | 98.5% | 98.8% | 99.0% |
| 100% load | 98.6% | 98.8% | 99.0% | 99.1% |

ECO Mode

| UPS rating | 60 kW | 80 kW | 100 kW |
|------------|-------|-------|--------|
| 25% load | 98.1% | 98.4% | 98.6% |
| 50% load | 98.9% | 99.0% | 99.1% |
| 75% load | 99.1% | 99.2% | 99.3% |
| 100% load | 99.2% | 99.3% | 99.3% |

eConversion

| UPS rating | 20 kW with N+1 power module | 30 kW with N+1 power module | 40 kW with N+1 power module | 50 kW with N+1 power module |
|------------|-----------------------------|-----------------------------|-----------------------------|-----------------------------|
| 25% load | 94.7% | 93.8% | 95.4% | 96.3% |
| 50% load | 97.2% | 96.8% | 97.5% | 98.0% |
| 75% load | 98.0% | 97.7% | 98.3% | 98.5% |
| 100% load | 98.4% | 98.3% | 98.6% | 98.8% |

eConversion

| UPS rating | 60 kW | 80 kW | 100 kW |
|------------|-------|-------|--------|
| 25% load | 97.3% | 97.5% | 97.9% |
| 50% load | 98.5% | 98.6% | 98.8% |
| 75% load | 98.9% | 98.9% | 99.0% |
| 100% load | 99.1% | 99.0% | 99.1% |

Battery Operation

| UPS rating | 20 kW with N+1 power module | 30 kW with N+1 power module | 40 kW with N+1 power module | 50 kW with N+1 power module |
|------------|-----------------------------|-----------------------------|-----------------------------|-----------------------------|
| 25% load | 92.4% | 92.2% | 93.4% | 94.2% |
| 50% load | 94.9% | 94.7% | 95.3% | 95.7% |
| 75% load | 95.8% | 95.6% | 96.0% | 96.3% |
| 100% load | 96.2% | 96.0% | 96.3% | 96.5% |

Battery Operation

| UPS rating | 60 kW | 80 kW | 100 kW |
|------------|-------|-------|--------|
| 25% load | 95.3% | 95.5% | 95.9% |
| 50% load | 96.3% | 96.4% | 96.5% |
| 75% load | 96.6% | 96.6% | 96.6% |
| 100% load | 96.6% | 96.6% | 96.5% |

208 V UPS

| 10 kW with N+1 power module | Normal operation | | | ECO mode | | |
|-----------------------------|------------------|-------|-------|----------|-------|-------|
| | 200 | 208 | 220 | 200 | 208 | 220 |
| 25% load | 91.5% | 91.4% | 91.4% | 91.9% | 92.1% | 92.2% |
| 50% load | 94.2% | 94.2% | 94.2% | 95.6% | 95.6% | 95.7% |
| 75% load | 94.9% | 94.9% | 95.1% | 97.0% | 97.0% | 97.0% |
| 100% load | 95.0% | 95.2% | 95.3% | 97.5% | 97.5% | 97.6% |

| 10 kW with N+1 power module | eConversion | | | Battery operation | | |
|-----------------------------|-------------|-------|-------|-------------------|-------|-------|
| | 200 | 208 | 220 | 200 | 208 | 220 |
| 25% load | 92.2% | 92.4% | 92.3% | 89.9% | 89.9% | 90.1% |
| 50% load | 95.9% | 95.9% | 95.9% | 93.1% | 93.2% | 93.4% |
| 75% load | 96.9% | 97.0% | 97.0% | 94.0% | 94.1% | 94.3% |
| 100% load | 97.5% | 97.5% | 97.5% | 94.2% | 94.4% | 94.6% |

| 15 kW with N+1 power module | Normal operation | | | ECO mode | | |
|-----------------------------|------------------|-------|-------|----------|-------|-------|
| | 200 | 208 | 220 | 200 | 208 | 220 |
| 25% load | 91.1% | 91.1% | 91.0% | 93.5% | 93.4% | 93.5% |
| 50% load | 94.0% | 94.0% | 94.0% | 96.4% | 96.5% | 96.5% |
| 75% load | 94.9% | 95.0% | 95.0% | 97.3% | 97.3% | 97.4% |
| 100% load | 95.2% | 95.3% | 95.4% | 97.7% | 97.8% | 97.8% |

| 15 kW with N+1 power module | eConversion | | | Battery operation | | |
|-----------------------------|-------------|-------|-------|-------------------|-------|-------|
| | 200 | 208 | 220 | 200 | 208 | 220 |
| 25% load | 92.4% | 92.4% | 92.3% | 90.7% | 90.8% | 90.9% |
| 50% load | 95.7% | 95.8% | 95.9% | 93.5% | 93.6% | 93.7% |
| 75% load | 96.9% | 96.9% | 96.9% | 94.4% | 94.6% | 94.7% |
| 100% load | 97.5% | 97.6% | 97.6% | 94.9% | 95.0% | 95.2% |

| 20 kW with N+1 power module | Normal operation | | | ECO mode | | |
|-----------------------------|------------------|-------|-------|----------|-------|-------|
| | Voltage (V) | 200 | 208 | 220 | 200 | 208 |
| 25% load | 92.4% | 92.5% | 92.4% | 94.7% | 94.8% | 94.9% |
| 50% load | 94.7% | 94.7% | 94.7% | 97.1% | 97.1% | 97.2% |
| 75% load | 95.2% | 95.3% | 95.4% | 97.7% | 97.8% | 97.8% |
| 100% load | 95.4% | 95.5% | 95.6% | 98.0% | 98.1% | 98.1% |

| 20 kW with N+1 power module | eConversion | | | Battery operation | | |
|-----------------------------|-------------|-------|-------|-------------------|-------|-------|
| | Voltage (V) | 200 | 208 | 220 | 200 | 208 |
| 25% load | 94.0% | 94.0% | 93.9% | 92.1% | 92.2% | 92.3% |
| 50% load | 96.6% | 96.6% | 96.7% | 94.2% | 94.3% | 94.5% |
| 75% load | 97.5% | 97.6% | 97.6% | 94.9% | 95.0% | 95.2% |
| 100% load | 97.9% | 97.9% | 98.0% | 95.2% | 95.4% | 95.5% |

| 25 kW with N+1 power module | Normal operation | | | ECO mode | | |
|-----------------------------|------------------|-------|-------|----------|-------|-------|
| | Voltage (V) | 200 | 208 | 220 | 200 | 208 |
| 25% load | 93.5% | 93.5% | 93.5% | 95.7% | 95.7% | 95.8% |
| 50% load | 95.0% | 95.1% | 95.1% | 97.5% | 97.5% | 97.6% |
| 75% load | 95.4% | 95.5% | 95.6% | 98.0% | 98.0% | 98.1% |
| 100% load | 95.3% | 95.5% | 95.6% | 98.1% | 98.2% | 98.3% |

| 25 kW with N+1 power module | eConversion | | | Battery operation | | |
|-----------------------------|-------------|-------|-------|-------------------|-------|-------|
| | Voltage (V) | 200 | 208 | 220 | 200 | 208 |
| 25% load | 95.0% | 95.0% | 95.1% | 92.9% | 93.0% | 93.2% |
| 50% load | 97.1% | 97.1% | 97.2% | 94.6% | 94.7% | 94.9% |
| 75% load | 97.8% | 97.9% | 97.9% | 95.2% | 95.3% | 95.5% |
| 100% load | 98.1% | 98.1% | 98.2% | 95.4% | 95.5% | 95.7% |

| 30 kW | Normal operation | | | ECO mode | | |
|-----------|------------------|-------|-------|----------|-------|-------|
| | Voltage (V) | 200 | 208 | 220 | 200 | 208 |
| 25% load | 93.2% | 93.2% | 93.4% | 96.5% | 96.5% | 96.6% |
| 50% load | 94.3% | 94.5% | 94.8% | 97.9% | 97.9% | 98.0% |
| 75% load | 94.2% | 94.5% | 94.8% | 98.2% | 98.2% | 98.3% |
| 100% load | 93.6% | 94.0% | 94.5% | 98.3% | 98.3% | 98.4% |

| 30 kW | eConversion | | | Battery operation | | |
|-----------|-------------|-------|-------|-------------------|-------|-------|
| | Voltage (V) | 200 | 208 | 220 | 200 | 208 |
| 25% load | 96.5% | 96.4% | 96.6% | 94.1% | 94.2% | 94.2% |
| 50% load | 97.7% | 97.7% | 97.8% | 95.2% | 95.3% | 95.4% |
| 75% load | 98.1% | 98.1% | 98.2% | 95.3% | 95.5% | 95.7% |
| 100% load | 98.2% | 98.3% | 98.3% | 95.3% | 95.5% | 95.7% |

| 40 kW | Normal operation | | | ECO mode | | |
|--------------------|-------------------------|------------|------------|-----------------|------------|------------|
| Voltage (V) | 200 | 208 | 220 | 200 | 208 | 220 |
| 25% load | 93.3% | 93.4% | 94.7% | 97.1% | 97.2% | 97.2% |
| 50% load | 94.4% | 94.6% | 95.6% | 98.0% | 98.1% | 98.2% |
| 75% load | 94.2% | 95.3% | 95.5% | 98.2% | 98.3% | 98.4% |
| 100% load | 93.6% | 94.8% | 95.2% | 98.2% | 98.3% | 98.4% |

| 40 kW | eConversion | | | Battery operation | | |
|--------------------|--------------------|------------|------------|--------------------------|------------|------------|
| Voltage (V) | 200 | 208 | 220 | 200 | 208 | 220 |
| 25% load | 96.6% | 96.6% | 96.3% | 94.4% | 94.6% | 94.7% |
| 50% load | 97.8% | 97.9% | 97.9% | 95.3% | 95.4% | 95.6% |
| 75% load | 98.1% | 98.2% | 98.2% | 95.4% | 95.6% | 95.8% |
| 100% load | 98.2% | 98.2% | 98.3% | 95.3% | 95.5% | 95.7% |

| 50 kW | Normal operation | | | ECO mode | | |
|--------------------|-------------------------|------------|------------|-----------------|------------|------------|
| Voltage (V) | 200 | 208 | 220 | 200 | 208 | 220 |
| 25% load | 93.8% | 94.0% | 95.1% | 97.3% | 97.4% | 97.4% |
| 50% load | 94.3% | 95.4% | 95.6% | 98.2% | 98.2% | 98.3% |
| 75% load | 93.8% | 95.0% | 95.3% | 98.2% | 98.3% | 98.4% |
| 100% load | 92.8% | 94.3% | 94.7% | 98.2% | 98.3% | 98.4% |

| 50 kW | eConversion | | | Battery operation | | |
|--------------------|--------------------|------------|------------|--------------------------|------------|------------|
| Voltage (V) | 200 | 208 | 220 | 200 | 208 | 220 |
| 25% load | 97.3% | 97.2% | 97.3% | 94.8% | 94.9% | 95.1% |
| 50% load | 98.0% | 98.1% | 98.1% | 95.4% | 95.5% | 95.7% |
| 75% load | 98.2% | 98.2% | 98.3% | 95.3% | 95.5% | 95.7% |
| 100% load | 98.1% | 98.2% | 98.3% | 95.1% | 95.3% | 95.6% |

Derating Due to Load Power Factor

0.7 leading to 0.7 lagging without derating.

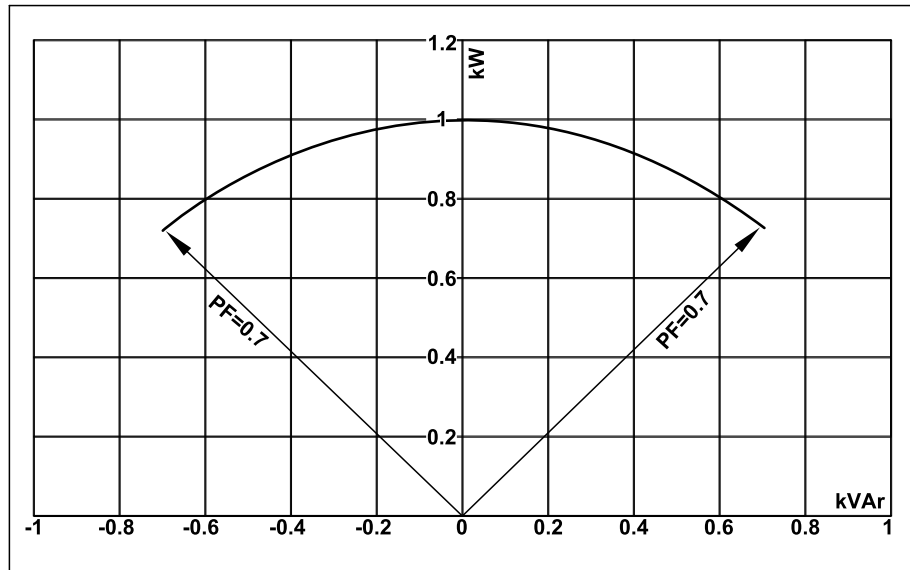

| UPS rating | UPS output | | | | | |
|------------|------------------|-----------------|------------------|------------------|-----------------|------------------|
| | Lagging | | | Leading | | |
| PF=1 | PF=0.7 | PF=0.8 | PF=0.9 | PF=0.9 | PF=0.8 | PF=0.7 |
| 10 kVA/kW | 10 kVA / 7 kW | 10 kVA / 8 kW | 10 kVA / 9 kW | 10 kVA / 9 kW | 10 kVA / 8 kW | 10 kVA / 7 kW |
| 15 kVA/kW | 15 kVA / 10.5 kW | 15 kVA / 12 kW | 15 kVA / 13.5 kW | 15 kVA / 13.5 kW | 15 kVA / 12 kW | 15 kVA / 10.5 kW |
| 20 kVA/kW | 20 kVA / 14 kW | 20 kVA / 16 kW | 20 kVA / 18 kW | 20 kVA / 18 kW | 20 kVA / 16 kW | 20 kVA / 14 kW |
| 25 kVA/kW | 25 kVA / 17.5 kW | 25 kVA / 20 kW | 25 kVA / 22.5 kW | 25 kVA / 22.5 kW | 25 kVA / 20 kW | 25 kVA / 17.5 kW |
| 30 kVA/kW | 30 kVA / 21 kW | 30 kVA / 24 kW | 30 kVA / 27 kW | 30 kVA / 27 kW | 30 kVA / 24 kW | 30 kVA / 21 kW |
| 40 kVA/kW | 40 kVA / 28 kW | 40 kVA / 32 kW | 40 kVA / 36 kW | 40 kVA / 36 kW | 40 kVA / 32 kW | 40 kVA / 28 kW |
| 50 kVA/kW | 50 kVA / 35 kW | 50 kVA / 40 kW | 50 kVA / 45 kW | 50 kVA / 45 kW | 50 kVA / 40 kW | 50 kVA / 35 kW |
| 60 kVA/kW | 60 kVA / 42 kW | 60 kVA / 48 kW | 60 kVA / 54 kW | 60 kVA / 54 kW | 60 kVA / 48 kW | 60 kVA / 42 kW |
| 80 kVA/kW | 80 kVA / 56 kW | 80 kVA / 64 kW | 80 kVA / 72 kW | 80 kVA / 72 kW | 80 kVA / 64 kW | 80 kVA / 56 kW |
| 100 kVA/kW | 100 kVA / 70 kW | 100 kVA / 80 kW | 100 kVA / 90 kW | 100 kVA / 90 kW | 100 kVA / 80 kW | 100 kVA / 70 kW |

Batteries

End of Discharge Voltage

The voltage is 1.6 to 1.75 per cell depending on discharge ratio.

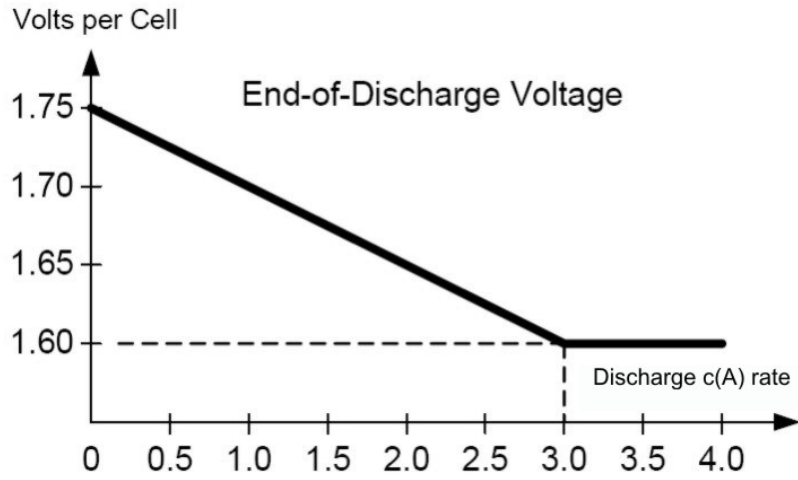

Battery Voltage Window

| | Boost 2.38 Vpc | Nominal 2.0 Vpc | Minimum 1.6 Vpc |
|---------------------|-----------------------|------------------------|------------------------|
| Battery voltage (V) | 571.2 | 480 | 384 |

Battery Runtimes in Minutes

NOTE: Runtimes are given at power factor 1 with 100% load.

480 V UPS

| UPS rating | 20 kW UPS with N+1 power module | 30 kW UPS with N+1 power module | 40 kW UPS with N+1 power module | 50 kW UPS with N+1 power module | 60 kW UPS | 80 kW UPS | 100 kW UPS |
|--------------------------------------|--|--|--|--|-----------|-----------|------------|
| Number of modular battery strings | | | | | | | |
| 1 | NA | NA | NA | NA | NA | NA | NA |
| 2 | 11.0 | 6.0 | NA | NA | NA | NA | NA |
| 3 | 18.5 | 10.5 | 7.3 | 5.2 | NA | NA | NA |
| 4 | 27.0 | 15.5 | 10.5 | 8.0 | 6.1 | NA | NA |
| 5 | 36.0 | 21.0 | 14.5 | 10.5 | 8.5 | 5.5 | NA |
| 6 | 45.0 | 26.5 | 18.5 | 14.0 | 11.0 | 7.3 | 5.2 |
| 7 | 54.5 | 32.5 | 22.5 | 17.0 | 13.5 | 9.1 | 6.6 |
| 8 | 64.0 | 38.0 | 27.0 | 20.0 | 16.0 | 10.5 | 8.0 |
| 9 | 74.0 | 44.0 | 31.0 | 23.5 | 18.5 | 12.5 | 9.5 |
| 10 | 84.0 | 50.5 | 35.5 | 27.0 | 21.5 | 14.5 | 11.0 |
| 11 | 94.5 | 56.5 | 40.0 | 30.5 | 24.0 | 16.5 | 12.5 |
| 12 | 105 | 63.0 | 44.5 | 34.0 | 27.0 | 18.5 | 14.0 |
| 13 | 115 | 69.5 | 49.0 | 37.5 | 30.0 | 20.5 | 15.5 |
| 14 | 125 | 76.0 | 54.0 | 41.0 | 32.5 | 22.5 | 17.0 |
| 15 | 135 | 82.5 | 58.5 | 44.5 | 35.5 | 24.5 | 18.5 |
| 16 | 145 | 89.5 | 63.5 | 48.0 | 38.5 | 27.0 | 20.0 |
| 17 | 155 | 96.0 | 68.0 | 52.0 | 41.5 | 29.0 | 22.0 |
| 18 | 170 | 100 | 73.0 | 56.0 | 44.5 | 31.0 | 23.5 |
| 19 | 180 | 110 | 78.0 | 59.5 | 48.0 | 33.5 | 25.5 |
| 20 | 190 | 115 | 83.0 | 63.5 | 51.0 | 35.5 | 27.0 |
| 21 | 205 | 120 | 88.0 | 67.5 | 54.0 | 38.0 | 28.5 |
| 22 | 215 | 130 | 93.5 | 71.0 | 57.0 | 40.0 | 30.5 |
| 23 | 225 | 135 | 98.5 | 75.0 | 60.5 | 42.5 | 32.0 |
| 24 | 240 | 145 | 100 | 79.0 | 63.5 | 44.5 | 34.0 |
| 25 | 250 | 150 | 105 | 83.0 | 67.0 | 47.0 | 35.5 |
| 26 | 265 | 160 | 110 | 87.5 | 70.0 | 49.0 | 37.5 |
| 27 | 275 | 165 | 115 | 91.5 | 73.5 | 51.5 | 39.5 |
| 28 | 285 | 175 | 125 | 95.5 | 76.5 | 54.0 | 41.0 |
| 29 | 300 | 180 | 130 | 99.5 | 80.0 | 56.5 | 43.0 |
| 30 | 310 | 190 | 135 | 100 | 83.5 | 58.5 | 45.0 |
| 31 | 325 | 195 | 140 | 105 | 87.0 | 61.0 | 46.5 |
| 32 | 335 | 205 | 145 | 110 | 90.0 | 63.5 | 48.5 |
| 33 | 350 | 210 | 150 | 115 | 93.5 | 66.0 | 50.5 |
| 34 | 360 | 220 | 155 | 120 | 97.0 | 68.5 | 52.0 |
| 35 | 375 | 225 | 160 | 125 | 100 | 71.0 | 54.0 |
| 36 | 390 | 235 | 165 | 125 | 100 | 73.0 | 56.0 |
| 37 | 400 | 240 | 170 | 130 | 105 | 75.5 | 58.0 |
| 38 | 415 | 250 | 180 | 135 | 110 | 78.0 | 60.0 |

| UPS rating | 20 kW UPS with N+1 power module | 30 kW UPS with N+1 power module | 40 kW UPS with N+1 power module | 50 kW UPS with N+1 power module | 60 kW UPS | 80 kW UPS | 100 kW UPS |
|-----------------------------------|---------------------------------|---------------------------------|---------------------------------|---------------------------------|-----------|-----------|------------|
| Number of modular battery strings | | | | | | | |
| 39 | 425 | 260 | 185 | 140 | 110 | 80.5 | 62.0 |
| 40 | 440 | 265 | 190 | 145 | 115 | 83.0 | 63.5 |
| 41 | 455 | 275 | 195 | 150 | 120 | 86.0 | 65.5 |

208 V UPS

| UPS rating | 10 kW UPS with N+1 power module | 15 kW UPS with N+1 power module | 20 kW UPS with N+1 power module | 25 kW UPS with N+1 power module | 30 kW UPS | 40 kW UPS | 50 kW UPS |
|-----------------------------------|---------------------------------|---------------------------------|---------------------------------|---------------------------------|-----------|-----------|-----------|
| Number of modular battery strings | | | | | | | |
| 1 | 11.0 | 5.9 | NA | NA | NA | NA | NA |
| 2 | 27.0 | 15.5 | 10.5 | 7.9 | 6.0 | NA | NA |
| 3 | 45.0 | 26.0 | 18.5 | 13.5 | 10.5 | 7.2 | 5.1 |
| 4 | 63.5 | 37.5 | 26.5 | 20.0 | 15.5 | 10.5 | 7.9 |
| 5 | 83.5 | 49.5 | 35.5 | 26.5 | 21.0 | 14.5 | 10.5 |
| 6 | 100 | 62.0 | 44.0 | 33.5 | 26.5 | 18.5 | 13.5 |
| 7 | 125 | 74.5 | 53.5 | 40.5 | 32.5 | 22.5 | 16.5 |
| 8 | 145 | 87.5 | 63.0 | 48.0 | 38.0 | 26.5 | 20.0 |
| 9 | 165 | 100 | 72.5 | 55.5 | 44.0 | 31.0 | 23.0 |
| 10 | 190 | 115 | 82.5 | 63.0 | 50.5 | 35.5 | 26.5 |
| 11 | 215 | 125 | 92.5 | 71.0 | 56.5 | 39.5 | 30.0 |
| 12 | 235 | 140 | 100 | 79.0 | 63.0 | 44.0 | 33.5 |
| 13 | 260 | 155 | 110 | 87.0 | 69.5 | 49.0 | 37.0 |
| 14 | 285 | 170 | 120 | 95.0 | 76.0 | 53.5 | 40.5 |
| 15 | 310 | 185 | 135 | 100 | 82.5 | 58.0 | 44.0 |
| 16 | 335 | 200 | 145 | 110 | 89.5 | 63.0 | 47.5 |
| 17 | 360 | 215 | 155 | 120 | 96.0 | 68.0 | 51.5 |
| 18 | 385 | 230 | 165 | 125 | 100 | 72.5 | 55.0 |
| 19 | 410 | 245 | 175 | 135 | 110 | 77.5 | 59.0 |
| 20 | 440 | 260 | 190 | 145 | 115 | 82.5 | 62.5 |
| 21 | 465 | 275 | 200 | 155 | 120 | 87.5 | 66.5 |
| 22 | 490 | 295 | 210 | 160 | 130 | 92.5 | 70.5 |
| 23 | 515 | 310 | 225 | 170 | 135 | 98.0 | 74.5 |
| 24 | 545 | 325 | 235 | 180 | 145 | 100 | 78.5 |
| 25 | 570 | 340 | 245 | 190 | 150 | 105 | 82.0 |
| 26 | 600 | 360 | 260 | 200 | 160 | 110 | 86.5 |
| 27 | 625 | 375 | 270 | 205 | 165 | 115 | 90.5 |
| 28 | 655 | 390 | 280 | 215 | 175 | 120 | 94.5 |
| 29 | 680 | 410 | 295 | 225 | 180 | 125 | 98.5 |
| 30 | 710 | 425 | 305 | 235 | 190 | 135 | 100 |
| 31 | 740 | 440 | 320 | 245 | 195 | 140 | 105 |
| 32 | 765 | 460 | 330 | 255 | 205 | 145 | 110 |
| 33 | 795 | 475 | 345 | 265 | 210 | 150 | 115 |
| 34 | 825 | 495 | 355 | 275 | 220 | 155 | 115 |
| 35 | 855 | 510 | 370 | 285 | 225 | 160 | 120 |

| UPS rating | 10 kW UPS with N+1 power module | 15 kW UPS with N+1 power module | 20 kW UPS with N+1 power module | 25 kW UPS with N+1 power module | 30 kW UPS | 40 kW UPS | 50 kW UPS |
|-----------------------------------|---------------------------------|---------------------------------|---------------------------------|---------------------------------|-----------|-----------|-----------|
| Number of modular battery strings | | | | | | | |
| 36 | 880 | 530 | 380 | 295 | 235 | 165 | 125 |
| 37 | 910 | 545 | 395 | 300 | 240 | 170 | 130 |
| 38 | 940 | 565 | 405 | 310 | 250 | 175 | 135 |
| 39 | 970 | 580 | 420 | 320 | 260 | 180 | 140 |
| 40 | 1000 | 600 | 435 | 330 | 265 | 190 | 145 |
| 41 | 1000 | 615 | 445 | 340 | 275 | 195 | 145 |

Compliance

| | |
|----------------|---|
| Safety | IEC 62040-1: 2008-06, 1st edition Uninterruptible Power Systems (UPS) - Part 1: General and safety requirements for UPS IEC 62040-1: 2013-01, 1st edition amendment 1 UL 1778 5th edition |
| EMC/EMI/RFI | IEC 62040-2: 2016, 3rd edition Uninterruptible Power Systems (UPS) - Part 2: Electromagnetic compatibility (EMC) requirements C2 FCC Part 15 Subpart B, Class A IEEE C62.41-1991 Location Category B2, IEEE Recommended Practice on Surge Voltages in Low-Voltage AC Power Circuits |
| Transportation | IEC 60721-4-2 Level 2M1 |
| Seismic | ICC-ES AC 156 (2015): OHSPD Pre-approved; Sds=1.33 g for z/h=1 and Sds=1.63 g for z/h=0; Ip= 1.5 |

Performance

Performance in accordance with: IEC 62040-3: 2021, 3rd edition Uninterruptible Power Systems (UPS) - Part 3: Method of specifying the performance and test requirements.

Regional Seismic Compliance

Certificate available upon request.

| Country/Region | Code ID | Hazard level ground | Hazard level roof |
|----------------------|---------------------------------|-----------------------------------|-----------------------------------|
| Argentina | INPRES-CIRSOC103 | Zone 4 | Zone 4 |
| Australia | AS 1170.4-2007 | Z = 0.22 | Z = 0.22 |
| Canada ¹⁵ | 2020 NBCC | S _a = 2.0 | S _a = 1.46 |
| Chile | NCh 433.Of1996 | Zone 3 | Zone 2 |
| China | GB 50011-2010 (2016) | α _{Max} = 1.4 | α _{Max} = 1.2 |
| Europe | Eurocode 8 EN1998-1 | α _{gR} = 0.45 | α _{gR} = 0.3 |
| India | IS 1893 (Part 1) : 2016 | Z = 0.36 | Z = 0.36 |
| Japan | Building Standard Law | Zone A | Zone A |
| New Zealand | NZS 1170.5:2004+A1 | Z = 0.6 | Z = 0.42 |
| Peru | N.T.E. - E.030 | Zone 4 | Zone 4 |
| Russia | SNIP II-7-81 (SP 14.13330.2014) | MSK 10 | MSK 9 |
| Taiwan | CPA 2011 Seismic Design Code | S _S ^D = 0.8 | S _S ^D = 0.8 |
| U.S.A. ¹⁵ | ASCE 7-16 / IBC 2018 | S _{DS} = 2.0 | S _{DS} = 1.47 |

15. OSHPD Pre-approved in accordance with AC156 test protocol.

Communication and Management

| | |
|---------------------------|---|
| Local area network | 1 Gbps – 1 port as default |
| Modbus | Modbus (SCADA) |
| Output relays | 4 x SELV configurable |
| Input contacts | 4 x SELV configurable |
| Standard control panel | 4.3 inch touchscreen display |
| Audible alarm | Yes |
| Emergency Power Off (EPO) | Options: <ul style="list-style-type: none"> • Normally Open (NO) • Normally Closed (NC) • External 24 VDC SELV |
| External switchgear | UIB UOB SSIB MBB SIB |
| External synchronization | No |
| Battery monitoring | Available for modular batteries |

EPO

EPO Configurations (640–4864 terminal J6600, 1–9)

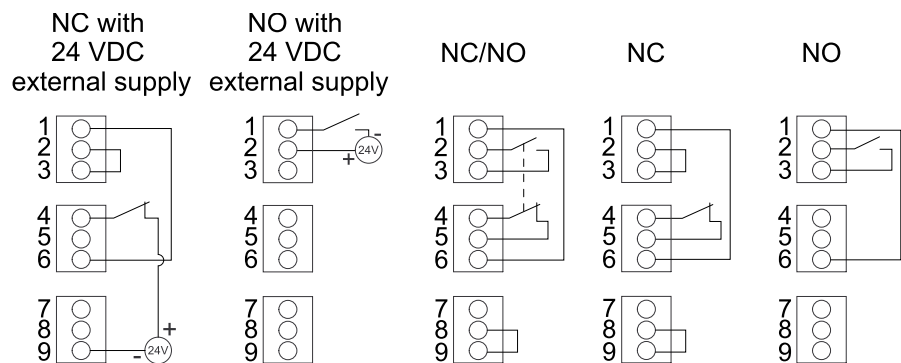

The EPO input supports 24 VDC.

NOTE: The default setting for the EPO activation is to turn off the inverter.

If you want the EPO activation to transfer the UPS into forced static bypass operation instead, please contact Schneider Electric.

Configurable Input Contacts and Output Relays

Input Contacts

Four input contacts are available and can be configured to indicate a given event via the display. The input contacts support 24 VDC 10 mA.

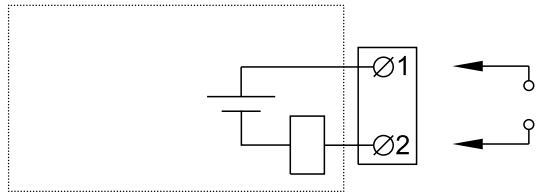

| Name | Description | Location |
|------------------------|----------------------------|------------------------------|
| IN_1 (input contact 1) | Configurable input contact | 640-4864 terminal J6616, 1-2 |
| IN_2 (input contact 2) | Configurable input contact | 640-4864 terminal J6616, 3-4 |
| IN_3 (input contact 3) | Configurable input contact | 640-4864 terminal J6616, 5-6 |
| IN_4 (input contact 4) | Configurable input contact | 640-4864 terminal J6616, 7-8 |

Output Relays

Four output relays are available and can be configured to activate on one or more events via the display.

The output relays support 24 VAC/VDC 1 A. All external circuitry must be fused with maximum 1 A fast acting fuses.

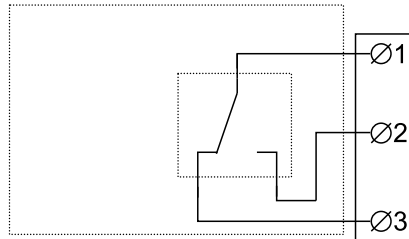

| Name | Description | Location |
|------------------------|---------------------------|--------------------------------|
| OUT_1 (output relay 1) | Configurable output relay | 640-4864 terminal J6617, 1-3 |
| OUT_2 (output relay 2) | Configurable output relay | 640-4864 terminal J6617, 4-6 |
| OUT_3 (output relay 3) | Configurable output relay | 640-4864 terminal J6617, 7-9 |
| OUT_4 (output relay 4) | Configurable output relay | 640-4864 terminal J6617, 10-12 |

Energized check mode: When this mode is enabled, it means that the output relay is activated when the events associated with the output relay are not present (normally activated). **Energized check mode** is individually set for each output relay and makes it possible to detect if the power supply to the output relays is lost, as all output relays will deactivate and the events associated with the output relays will be indicated as present.

Specifications

Specifications for 480 V Systems

The supply for input and bypass must be solid-grounded WYE transformers. Delta input supply for either input or bypass is not permitted.

The UPS system must be installed as a separately derived system. Leakage currents will occur in the bonding jumper and the technical/system earth.

Input Specifications 480 V

| UPS rating | 20 kW with N+1 power module | 30 kW with N+1 power module | 40 kW with N+1 power module | 50 kW with N+1 power module |
|----------------------------------|---|-----------------------------|-----------------------------|-----------------------------|
| Connections | 3-wire (L1, L2, L3, G) WYE or 4-wire (L1, L2, L3, N, G) WYE (single mains) 3-wire (L1, L2, L3, G) WYE (dual mains) ¹⁶ | | | |
| Input voltage range (V) | 408-552 | | | |
| Frequency range (Hz) | 40-70 | | | |
| Nominal input current (A) | 25 | 37 | 50 | 62 |
| Maximum input current (A) | 30 | 45 | 60 | 74 |
| Input current limitation (A) | 31 | 47 | 62 | 77 |
| Input power factor | 0.99 at 100% load | | | |
| Total harmonic distortion (THDI) | <6% at full linear load (symmetrical) | | | |
| Maximum short circuit rating | 65 kA RMS | | | |
| Protection | Built-in backfeed protection and fuses | | | |
| Ramp-in | Programmable and adaptive 1-40 seconds | | | |

| UPS rating | 60 kW | 80 kW | 100 kW |
|----------------------------------|---|-------|--------|
| Connections | 3-wire (L1, L2, L3, G) WYE or 4-wire (L1, L2, L3, N, G) WYE (single mains) 3-wire (L1, L2, L3, G) WYE (dual mains) ¹⁶ | | |
| Input voltage range (V) | 408-552 | | |
| Frequency range (Hz) | 40-70 | | |
| Nominal input current (A) | 74 | 99 | 124 |
| Maximum input current (A) | 89 | 119 | 149 |
| Input current limitation (A) | 93 | 124 | 154 |
| Input power factor | 0.99 for load greater than 50% 0.95 for load greater than 25% | | |
| Total harmonic distortion (THDI) | <3% at full linear load (symmetrical) | | |
| Maximum short circuit rating | 65 kA RMS | | |

16. TN and TT power distribution systems are supported. Corner (line) grounding is not supported.

| UPS rating | 60 kW | 80 kW | 100 kW |
|------------|--|-------|--------|
| Protection | Built-in backfeed protection and fuses | | |
| Ramp-in | Programmable and adaptive 1-40 seconds | | |

Bypass Specifications 480 V

| UPS rating | 20 kW with N+1 power module | 30 kW with N+1 power module | 40 kW with N+1 power module | 50 kW with N+1 power module |
|--|---|-----------------------------|-----------------------------|-----------------------------|
| Connections | 3-wire (L1, L2, L3, G) WYE or 4-wire (L1, L2, L3, N, G) WYE ¹⁷ | | | |
| Bypass voltage range (V) | 432-528 | | | |
| Frequency range (Hz) | 50/60 ± 1, 50/60 ± 3, 50/60 ± 10 (user selectable) | | | |
| Nominal bypass current (A) | 24 | 36 | 49 | 61 |
| Nominal neutral current (A) | 42 | 62 | 83 | 104 |
| Maximum short circuit rating ¹⁸ | 65 kA RMS | | | |
| Protection | Built-in backfeed protection and fuses Internal fuse specifications: Rated 400 A, prearcing 33 kA ² s | | | |

| UPS rating | 60 kW | 80 kW | 100 kW |
|--|---|-------|--------|
| Connections | 3-wire (L1, L2, L3, G) WYE or 4-wire (L1, L2, L3, N, G) WYE ¹⁷ | | |
| Bypass voltage range (V) | 432-528 | | |
| Frequency range (Hz) | 50/60 ± 1, 50/60 ± 3, 50/60 ± 10 (user selectable) | | |
| Nominal bypass current (A) | 73 | 97 | 121 |
| Nominal neutral current (A) | 125 | 166 | 208 |
| Maximum short circuit rating ¹⁸ | 65 kA RMS | | |
| Protection | Built-in backfeed protection and fuses Internal fuse specifications: Rated 400 A, prearcing 33 kA ² s | | |

17. TN and TT power distribution systems are supported. Corner (line) grounding is not supported.

18. Conditioned by the internal fuse rated 400 A, prearcing 33 kA²s.

Output Specifications 480 V

NOTE: The number of output connections must match the number of input wires in a single mains system or bypass wires in a dual mains system.

| UPS rating | 20 kW with N+1 power module | 30 kW with N+1 power module | 40 kW with N+1 power module | 50 kW with N+1 power module |
|----------------------------------|---|-----------------------------|-----------------------------|-----------------------------|
| Connections | 3-wire (L1, L2, L3, G, GEC ¹⁹) or 4-wire (L1, L2, L3, N, G) | | | |
| Output voltage regulation | Symmetrical load $\pm 1\%$ Asymmetrical load $\pm 3\%$ | | | |
| Overload capacity | 150% for 1 minute (in normal operation) 125% for 10 minutes (in normal operation) 125% for 1 minute (in battery operation) 125% continuous (bypass operation) 1000% for 100 milliseconds (bypass operation) | | | |
| Dynamic load response | $\pm 5\%$ after 2 milliseconds $\pm 1\%$ after 50 milliseconds | | | |
| Output power factor | 1 | | | |
| Nominal output current (A) | 24 | 36 | 48 | 60 |
| Frequency regulation (Hz) | 50/60 Hz bypass synchronized – 50/60 Hz $\pm 0.1\%$ free-running | | | |
| Synchronized slew rate (Hz/sec) | Programmable to 0.25, 0.5, 1, 2, 4, 6 | | | |
| Total harmonic distortion (THDU) | <1% for linear load <3% for non-linear load | | | |
| Load crest factor | 2.5 | | | |
| Load power factor | From 0.7 leading to 0.7 lagging without any derating | | | |

| UPS rating | 60 kW | 80 kW | 100 kW |
|----------------------------------|---|-------|--------|
| Connections | 3-wire (L1, L2, L3, G, GEC ¹⁹) or 4-wire (L1, L2, L3, N, G) | | |
| Output voltage regulation | Symmetrical load $\pm 1\%$ Asymmetrical load $\pm 3\%$ | | |
| Overload capacity | 150% for 1 minute (in normal operation) 125% for 10 minutes (in normal operation) 125% for 1 minute (in battery operation) 125% continuous (bypass operation) 1000% for 100 milliseconds (bypass operation) | | |
| Dynamic load response | $\pm 5\%$ after 2 milliseconds $\pm 1\%$ after 50 milliseconds | | |
| Output power factor | 1 | | |
| Nominal output current (A) | 72 | 96 | 120 |
| Frequency regulation (Hz) | 50/60 Hz bypass synchronized – 50/60 Hz $\pm 0.1\%$ free-running | | |
| Synchronized slew rate (Hz/sec) | Programmable to 0.25, 0.5, 1, 2, 4, 6 | | |
| Total harmonic distortion (THDU) | <1% for linear load <3% for non-linear load | | |
| Load crest factor | 2.5 | | |
| Load power factor | From 0.7 leading to 0.7 lagging without any derating | | |

19. Per NEC 250.30.

Battery Specifications 480 V

⚡ ⚠ DANGER

HAZARD OF ELECTRIC SHOCK, EXPLOSION, OR ARC FLASH

Protection of the energy storage device: An overcurrent protective device must be located in close proximity to the energy storage device.

Failure to follow these instructions will result in death or serious injury.

| UPS rating | 20 kW with N+1 power module | 30 kW with N+1 power module | 40 kW with N+1 power module | 50 kW with N+1 power module | 60 kW | 80 kW | 100 kW |
|--|--|-----------------------------|-----------------------------|-----------------------------|-------|-------|--------|
| Charging power in % of output power at 0-40% load | 80% | | | | | | |
| Charging power in % of output power at 100% load | 20% | | | | | | |
| Maximum charging power (at 0-40% load) (kW) | 16 | 24 | 32 | 40 | 48 | 64 | 80 |
| Maximum charging power (at 100% load) (kW) | 4 | 6 | 8 | 10 | 12 | 16 | 20 |
| Nominal battery voltage (VDC) | 480 | | | | | | |
| Nominal float voltage (VDC) | 545 | | | | | | |
| Maximum boost voltage (VDC) | 572 | | | | | | |
| Temperature compensation (per cell) | -3.3mV/°C, for T ≥ 25 °C – 0mV/°C, for T < 25 °C | | | | | | |
| End of discharge voltage (full load) (VDC) | 384 | | | | | | |
| Battery current at full load and nominal battery voltage (A) | 43 | 65 | 87 | 109 | 130 | 174 | 217 |
| Battery current at full load and minimum battery voltage (A) | 54 | 81 | 109 | 136 | 163 | 217 | 271 |
| Ripple current | < 5% C20 (5 minute runtime) | | | | | | |
| Battery test | Manual/automatic (selectable) | | | | | | |
| Maximum short circuit rating | 10 kA | | | | | | |

Recommended Cable Sizes 480 V

⚠️ ⚠️ DANGER

HAZARD OF ELECTRIC SHOCK, EXPLOSION, OR ARC FLASH

All wiring must comply with all applicable national and/or electrical codes. The maximum allowable cable size is 300 kcmil.

Failure to follow these instructions will result in death or serious injury.

The maximum number of cable connections per busbar: Two on input/output/bypass busbars; Four on DC busbars; Six on N/G busbars.

NOTE: Overcurrent protection is to be provided by others.

Cable sizes in this manual are based on Table 310.15 (B)(16) of the National Electrical Code (NEC) with the following assertions:

- 90 °C (194 °F) conductors (75 °C (167 °F) termination)
- An ambient temperature of 30 °C (86 °F)
- Use of copper conductors

If the ambient temperature is greater than 30 °C (86 °F), larger conductors are to be selected in accordance with the correction factors of the NEC.

Equipment grounding conductors (EGC) are sized in accordance with NEC Article 250.122 and Table 250.122.

NOTE: Recommended cable sizes and maximum allowable cable size may vary for the auxiliary products. Not all auxiliary products support aluminum cables. Refer to the installation manual provided with the auxiliary product.

NOTE: The DC cable sizes given here are recommendations – Always follow the specific instructions in the battery solution documentation for DC cable sizes and DC EGC cable sizes and ensure that the DC cable sizes match the battery breaker rating.

NOTE: Neutral conductor is sized to handle 1.73 times phase current in case of high harmonic content from non-linear loads. If non or less harmonic currents are expected, neutral conductor can be sized accordingly but not less than the phase conductor.

| UPS rating | 20 kW with N+1 power module | 30 kW with N+1 power module | 40 kW with N+1 power module | 50 kW with N+1 power module | 60 kW | 80 kW | 100 kW |
|-----------------------------------|-----------------------------|-----------------------------|-----------------------------|-----------------------------|-------|-------|---------|
| Input phases (AWG/kcmil) | 8 | 6 | 4 | 3 | 1 | 2/0 | 3/0 |
| Input EGC (AWG/kcmil) | 10 | 8 | 8 | 6 | 6 | 6 | 4 |
| Bypass/output phases (AWG/kcmil) | 10 | 8 | 6 | 4 | 3 | 1 | 2/0 |
| Bypass EGC/output EGC (AWG/kcmil) | 10 | 10 | 8 | 8 | 8 | 6 | 6 |
| Neutral (AWG/kcmil) | 6 | 4 | 2 | 1/0 | 2/0 | 4/0 | 2 x 1/0 |
| DC+/DC-(AWG/kcmil) | 6 | 4 | 2 | 1/0 | 2/0 | 4/0 | 2 x 1/0 |
| DC EGC (AWG/kcmil) | 8 | 6 | 6 | 6 | 6 | 4 | 4 |

NOTE: Cable sizes are based on 80% rated circuit breakers for UIB, UOB, MBB, SSIB, and 100% rated circuit breaker for battery breaker(s).

Recommended Upstream Protection 480 V

⚡⚠ DANGER

HAZARD OF ELECTRIC SHOCK, EXPLOSION, OR ARC FLASH

- For parallel systems, instantaneous override (Ii) values must not be set higher than 1250 A. Place the label 885-92556 adjacent to the upstream circuit breaker to inform about the hazard.
- In parallel systems with three or more UPSs, a circuit breaker must be installed on the output of each UPS. The unit output breaker (UOB) instantaneous override (Ii) values must not be set higher than 1250 A.

Failure to follow these instructions will result in death or serious injury.

⚠ CAUTION

HAZARD OF FIRE

- Connect only to a circuit with the below specifications.
- Connect to a circuit provided with a 250 A branch circuit overcurrent protection maximum in accordance with the National Electrical Code, ANSI/NFPA70, and the Canadian Electrical Code, Part I, C22.1.

Failure to follow these instructions can result in injury or equipment damage.

NOTE: Overcurrent protection is to be provided by others and marked with its function.

| UPS rating | 20 kW with N+1 power module | | 30 kW with N+1 power module | | 40 kW with N+1 power module | | 50 kW with N+1 power module | |
|--------------------|-----------------------------|--------|-----------------------------|--------|-----------------------------|--------|-----------------------------|--------|
| | Input | Bypass | Input | Bypass | Input | Bypass | Input | Bypass |
| Breaker type | HJF36100U31X | | | | | | | |
| Ir setting | 40 | 35 | 60 | 50 | 80 | 70 | 100 | 80 |
| Tr at 6 Ir setting | 0.5 | | | | | | | |
| Ii (x In) setting | 1.5 | | | | | | | |

| UPS rating | 60 kW | | 80 kW | | 100 kW | |
|--------------------|--------------|--------------|--------------|--------------|--------------|--------|
| | Input | Bypass | Input | Bypass | Input | Bypass |
| Breaker type | HJF36150U31X | HJF36100U31X | JJF36250U31X | HJF36150U31X | JJF36250U31X | |
| Ir setting | 125 | 100 | 175 | 125 | 200 | 175 |
| Tr at 6 Ir setting | 0.5 | | | | | |
| Ii (x In) setting | 1.5 | | | | | |

Specifications for 208 V Systems

Input Specifications 208 V

| UPS rating | 10 kW with N+1 power module | 15 kW with N+1 power module | 20 kW with N+1 power module | 25 kW with N+1 power module |
|----------------------------------|---|-----------------------------|-----------------------------|-----------------------------|
| Voltage (V) | 200/208/220 | 200/208/220 | 200/208/220 | 200/208/220 |
| Connections | 4-wire (L1, L2, L3, N, G) WYE (single mains) 3-wire (L1, L2, L3, G) WYE (dual mains) | | | |
| Input voltage range (V) | 200 V: 170-230 208 V: 177-239 220 V: 187-253 | | | |
| Frequency range (Hz) | 40-70 | | | |
| Nominal input current (A) | 31/30/28 | 47/45/42 | 62/60/56 | 78/75/71 |
| Maximum input current (A) | 37/36/34 | 56/54/51 | 74/72/68 | 91/90/85 |
| Input current limitation (A) | 39/37/35 | 58/55/52 | 77/74/70 | 91/91/87 |
| Input power factor | 0.99 at 100% load | | | |
| Total harmonic distortion (THDI) | <6% at full linear load (symmetrical) | | | |
| Maximum short circuit rating | 65 kA RMS | | | |
| Protection | Built-in backfeed protection and fuses | | | |
| Ramp-in | Programmable and adaptive 1-40 seconds | | | |

| UPS rating | 30 kW | 40 kW | 50 kW |
|----------------------------------|---|--------------------|--------------------|
| Voltage (V) | 200/208/220 | 200/208/220 | 200/208/220 |
| Connections | 4-wire (L1, L2, L3, N, G) WYE (single mains) 3-wire (L1, L2, L3, G) WYE (dual mains) | | |
| Input voltage range (V) | 200 V: 170-230 208 V: 177-239 220 V: 187-253 | | |
| Frequency range (Hz) | 40-70 | | |
| Nominal input current (A) | 93/90/85 | 124/119/113 | 155/149/141 |
| Maximum input current (A) | 112/107/102 | 149/143/135 | 182/179/169 |
| Input current limitation (A) | 115/110/104 | 153/147/139 | 182/182/174 |
| Input power factor | 0.99 for load greater than 50% 0.95 for load greater than 25% | | |
| Total harmonic distortion (THDI) | <3% at full linear load (symmetrical) | | |
| Maximum short circuit rating | 65 kA RMS | | |
| Protection | Built-in backfeed protection and fuses | | |
| Ramp-in | Programmable and adaptive 1-40 seconds | | |

Bypass Specifications 208 V

| UPS rating | 10 kW with N+1 power module | 15 kW with N+1 power module | 20 kW with N+1 power module | 25 kW with N+1 power module |
|--|--|-----------------------------|-----------------------------|-----------------------------|
| Voltage (V) | 200/208/220 | 200/208/220 | 200/208/220 | 200/208/220 |
| Connections | 4-wire (L1, L2, L3, N, G) WYE | | | |
| Bypass voltage range (V) | 200 V: 180-220 208 V: 187-229 220 V: 198-242 | | | |
| Frequency range (Hz) | 50/60 ± 1, 50/60 ± 3, 50/60 ± 10 (user selectable) | | | |
| Nominal bypass current (A) | 29/28/27 | 44/42/40 | 58/56/53 | 73/70/66 |
| Nominal neutral current (A) | 50/48/45 | 75/72/68 | 100/96/91 | 125/120/114 |
| Maximum short circuit rating ²⁰ | 65 kA RMS | | | |
| Protection | Built-in backfeed protection and fuses Internal fuse specifications: Rated 400 A, prearcing 33 kA ^{2s} | | | |

| UPS rating | 30 kW | 40 kW | 50 kW |
|--|--|--------------------|--------------------|
| Voltage (V) | 200/208/220 | 200/208/220 | 200/208/220 |
| Connections | 4-wire (L1, L2, L3, N, G) WYE | | |
| Bypass voltage range (V) | 200 V: 180-220 208 V: 187-229 220 V: 198-242 | | |
| Frequency range (Hz) | 50/60 ± 1, 50/60 ± 3, 50/60 ± 10 (user selectable) | | |
| Nominal bypass current (A) | 87/84/80 | 117/112/106 | 146/140/133 |
| Nominal neutral current (A) | 150/144/136 | 200/192/182 | 250/240/227 |
| Maximum short circuit rating ²⁰ | 65 kA RMS | | |
| Protection | Built-in backfeed protection and fuses Internal fuse specifications: Rated 400 A, prearcing 33 kA ^{2s} | | |

20. Conditioned by the internal fuse rated 400 A, prearcing 33 kA^{2s}.

Output Specifications 208 V

| UPS rating | 10 kW with N+1 power module | 15 kW with N+1 power module | 20 kW with N+1 power module | 25 kW with N+1 power module |
|----------------------------------|---|--|-----------------------------|-----------------------------|
| Voltage (V) | 200/208/220 | 200/208/220 | 200/208/220 | 200/208/220 |
| Connections | 4-wire (L1, L2, L3, N, G) | | | |
| Output voltage regulation | Symmetrical load $\pm 1\%$ Asymmetrical load $\pm 3\%$ | | | |
| Overload capacity | 150% for 1 minute (in normal operation) 125% for 10 minutes (in normal operation) 125% for 1 minute (in battery operation) 125% continuous (bypass operation) 1000% for 100 milliseconds (bypass operation) | | | |
| Dynamic load response | $\pm 5\%$ after 2 milliseconds $\pm 1\%$ after 50 milliseconds | | | |
| Output power factor | 1 | | | |
| Nominal output current (A) | 29/28/26 | 43/42/39 | 58/56/52 | 73/70/66 |
| Frequency regulation (Hz) | 50/60 Hz bypass synchronized – 50/60 Hz $\pm 0.1\%$ free-running | | | |
| Synchronized slew rate (Hz/sec) | Programmable to 0.25, 0.5, 1, 2, 4, 6 | | | |
| Total harmonic distortion (THDU) | <1% for linear load <5% for non-linear load | <1% for linear load <3% for non-linear load | | |
| Load crest factor | 2.5 | | | |
| Load power factor | From 0.7 leading to 0.7 lagging without any derating | | | |

| UPS rating | 30 kW | 40 kW | 50 kW |
|----------------------------------|---|--------------------|--------------------|
| Voltage (V) | 200/208/220 | 200/208/220 | 200/208/220 |
| Connections | 4-wire (L1, L2, L3, N, G) | | |
| Output voltage regulation | Symmetrical load $\pm 1\%$ Asymmetrical load $\pm 3\%$ | | |
| Overload capacity | 150% for 1 minute (in normal operation) 125% for 10 minutes (in normal operation) 125% for 1 minute (in battery operation) 125% continuous (bypass operation) 1000% for 100 milliseconds (bypass operation) | | |
| Dynamic load response | $\pm 5\%$ after 2 milliseconds $\pm 1\%$ after 50 milliseconds | | |
| Output power factor | 1 | | |
| Nominal output current (A) | 87/83/79 | 115/111/105 | 144/139/131 |
| Frequency regulation (Hz) | 50/60 Hz bypass synchronized – 50/60 Hz $\pm 0.1\%$ free-running | | |
| Synchronized slew rate (Hz/sec) | Programmable to 0.25, 0.5, 1, 2, 4, 6 | | |
| Total harmonic distortion (THDU) | <1% for linear load <5% for non-linear load | | |
| Load crest factor | 2.5 | | |
| Load power factor | From 0.7 leading to 0.7 lagging without any derating | | |

Battery Specifications 208 V

⚠ DANGER

HAZARD OF ELECTRIC SHOCK, EXPLOSION, OR ARC FLASH

Protection of the energy storage device: An overcurrent protective device must be located in close proximity to the energy storage device.

Failure to follow these instructions will result in death or serious injury.

| UPS rating | 10 kW with N+1 power module | 15 kW with N+1 power module | 20 kW with N+1 power module | 25 kW with N+1 power module | 30 kW | 40 kW | 50 kW |
|--|--|-----------------------------|-----------------------------|-----------------------------|-------|-------|-------|
| Charging power in % of output power at 0-40% load | 80% | | | | | | |
| Charging power in % of output power at 100% load | 20% | | | | | | |
| Maximum charging power (at 0-40% load) (kW) | 8 | 12 | 16 | 20 | 24 | 32 | 40 |
| Maximum charging power (at 100% load) (kW) | 2 | 3 | 4 | 5 | 6 | 8 | 10 |
| Nominal battery voltage (VDC) | 480 | | | | | | |
| Nominal float voltage (VDC) | 545 | | | | | | |
| Maximum boost voltage (VDC) | 572 | | | | | | |
| Temperature compensation (per cell) | -3.3mV/°C, for T ≥ 25 °C – 0mV/°C, for T < 25 °C | | | | | | |
| End of discharge voltage (full load) (VDC) | 384 | | | | | | |
| Battery current at full load and nominal battery voltage (A) | 22 | 33 | 44 | 55 | 65 | 87 | 109 |
| Battery current at full load and minimum battery voltage (A) | 27 | 41 | 54 | 68 | 81 | 109 | 136 |
| Ripple current | < 5% C20 (5 minute runtime) | | | | | | |
| Battery test | Manual/automatic (selectable) | | | | | | |
| Maximum short circuit rating | 10 kA | | | | | | |

Recommended Cable Sizes 208 V

⚠️ ⚠️ DANGER

HAZARD OF ELECTRIC SHOCK, EXPLOSION, OR ARC FLASH

All wiring must comply with all applicable national and/or electrical codes. The maximum allowable cable size is 300 kcmil.

Failure to follow these instructions will result in death or serious injury.

The maximum number of cable connections per busbar: Two on input/output/bypass busbars; Four on DC busbars; Six on N/G busbars.

NOTE: Overcurrent protection is to be provided by others.

Cable sizes in this manual are based on Table 310.15 (B)(16) of the National Electrical Code (NEC) with the following assertions:

- 90 °C (194 °F) conductors (75 °C (167 °F) termination)
- An ambient temperature of 30 °C (86 °F)
- Use of copper conductors

If the ambient temperature is greater than 30 °C (86 °F), larger conductors are to be selected in accordance with the correction factors of the NEC.

Equipment grounding conductors (EGC) are sized in accordance with NEC Article 250.122 and Table 250.122.

NOTE: Recommended cable sizes and maximum allowable cable size may vary for the auxiliary products. Not all auxiliary products support aluminum cables. Refer to the installation manual provided with the auxiliary product.

NOTE: The DC cable sizes given here are recommendations – Always follow the specific instructions in the battery solution documentation for DC cable sizes and DC EGC cable sizes and ensure that the DC cable sizes match the battery breaker rating.

NOTE: Neutral conductor is sized to handle 1.73 times phase current in case of high harmonic content from non-linear loads. If non or less harmonic currents are expected, neutral conductor can be sized accordingly but not less than the phase conductor.

| UPS rating | 10 kW with N+1 power module | 15 kW with N+1 power module | 20 kW with N+1 power module | 25 kW with N+1 power module | 30 kW | 40 kW | 50 kW |
|-----------------------------------|-----------------------------|-----------------------------|-----------------------------|-----------------------------|-------|---------|---------|
| Input phases (AWG/kcmil) | 8 | 4 | 3 | 2 | 1/0 | 3/0 | 4/0 |
| Input EGC (AWG/kcmil) | 10 | 8 | 8 | 6 | 6 | 6 | 4 |
| Bypass/output phases (AWG/kcmil) | 8 | 6 | 4 | 3 | 2 | 1/0 | 3/0 |
| Bypass EGC/output EGC (AWG/kcmil) | 10 | 10 | 8 | 8 | 6 | 6 | 6 |
| Neutral (AWG/kcmil) | 6 | 3 | 1 | 2/0 | 3/0 | 2 x 1/0 | 2 x 2/0 |
| DC+/DC-(AWG/kcmil) | 10 | 8 | 6 | 4 | 4 | 2 | 1/0 |
| DC EGC (AWG/kcmil) | 10 | 10 | 8 | 8 | 6 | 6 | 6 |

NOTE: Cable sizes are based on 80% rated circuit breakers for UIB, UOB, MBB, SSIB, and 100% rated circuit breaker for battery breaker(s).

Recommended Upstream Protection 208 V

⚡⚠ DANGER

HAZARD OF ELECTRIC SHOCK, EXPLOSION, OR ARC FLASH

- For parallel systems, instantaneous override (Ii) values must not be set higher than 1250 A. Place the label 885-92556 adjacent to the upstream circuit breaker to inform about the hazard.
- In parallel systems with three or more UPSs, a circuit breaker must be installed on the output of each UPS. The unit output breaker (UOB) instantaneous override (Ii) values must not be set higher than 1250 A.

Failure to follow these instructions will result in death or serious injury.

⚠ CAUTION

HAZARD OF FIRE

- Connect only to a circuit with the below specifications.
- Connect to a circuit provided with a 250 A branch circuit overcurrent protection maximum in accordance with the National Electrical Code, ANSI/NFPA70, and the Canadian Electrical Code, Part I, C22.1.

Failure to follow these instructions can result in injury or equipment damage.

NOTE: Overcurrent protection is to be provided by others and marked with its function.

| UPS rating | 10 kW with N+1 power module | | 15 kW with N+1 power module | | 20 kW with N+1 power module | | 25 kW with N+1 power module | |
|--|-----------------------------|--------|-----------------------------|--------|-----------------------------|--------|-----------------------------|---------------|
| | Input | Bypass | Input | Bypass | Input | Bypass | Input | Bypass |
| Breaker type | HJF36100U31X | | | | | | HJF36150-U31X | HJF36100-U31X |
| I _r setting | 50 | 40 | 80 | 60 | 100 | 80 | 125 | 100 |
| Tr at 6 I _r setting | 0.5 | | | | | | | |
| I _i (x I _n) setting | 1.5 | | | | | | | |

| UPS rating | 30 kW | | 40 kW | | 50 kW | |
|--|--------------|--------|--------------|--------------|--------------|--------|
| | Input | Bypass | Input | Bypass | Input | Bypass |
| Breaker type | HJF36150U31X | | JJF36250U31X | HJF36150U31X | JJF36250U31X | |
| I _r setting | 150 | 110 | 200 | 150 | 250 | 200 |
| Tr at 6 I _r setting | 0.5 | | | | | |
| I _i (x I _n) setting | 1.5 | | | | | |

Torque Specifications

| Bolt size | Torque |
|-----------|-------------------------------------|
| M4 | 1.7 Nm (1.25 lb-ft / 15 lb-in) |
| M5 | 2.2 Nm (1.62 lb-ft / 19.5 lb-in) |
| M6 | 5 Nm (3.69 lb-ft / 44.3 lb-in) |
| M8 | 17.5 Nm (12.91 lb-ft / 154.9 lb-in) |
| M10 | 30 Nm (22 lb-ft / 194.7 lb-in) |
| M12 | 50 Nm (36.87 lb-ft / 442.5 lb-in) |

Environment

| | Operating | Storage |
|--|---|--|
| Temperature | 0 °C to 40 °C (32 °F to 104 °F) | -15 °C to 40 °C (5 °F to 104 °F) for systems with batteries. |
| Relative humidity | 0 - 95% non-condensing | 10 - 80% non-condensing |
| Elevation | Designed for operation in 0-3000 m (0-10000 feet) elevation. Power derating required from 1000-3000 m (3300-10000 feet): Up to 1000 m (3300 feet): 1.000 Up to 1500 m (5000 feet): 0.975 Up to 2000 m (6600 feet): 0.950 Up to 2500 m (8300 feet): 0.925 Up to 3000 m (10000 feet): 0.900 | |
| Audible noise one meter (three feet) from unit | 480 V 20-60 kW: 49 dB at 70% load, 54 dB at 100% load 480 V 80-100 kW: 57 dB at 70% load, 65 dB at 100% load 208 V 10-30 kW: 49 dB at 70% load, 54 dB at 100% load 208 V 40-50 kW: 57 dB at 70% load, 65 dB at 100% load | |
| Protection class | IP20 | |
| Color | RAL 9003, gloss level 85% | |

Heat Dissipation in BTU/hr

480 V UPS

Normal Operation

| UPS rating | 20 kW with N+1 power module | 30 kW with N+1 power module | 40 kW with N+1 power module | 50 kW with N+1 power module |
|------------|-----------------------------|-----------------------------|-----------------------------|-----------------------------|
| 25% load | 1301 | 2205 | 2566 | 2718 |
| 50% load | 1696 | 2890 | 3319 | 3781 |
| 75% load | 2022 | 3535 | 4169 | 4901 |
| 100% load | 2407 | 4189 | 5035 | 6115 |

Normal Operation

| UPS rating | 60 kW | 80 kW | 100 kW |
|------------|-------|-------|--------|
| 25% load | 2542 | 3341 | 3788 |
| 50% load | 3935 | 5056 | 6077 |
| 75% load | 5509 | 6969 | 8718 |
| 100% load | 7370 | 9229 | 12103 |

ECO Mode

| UPS rating | 20 kW with N+1 power module | 30 kW with N+1 power module | 40 kW with N+1 power module | 50 kW with N+1 power module |
|------------|-----------------------------|-----------------------------|-----------------------------|-----------------------------|
| 25% load | 785 | 960 | 1071 | 1042 |
| 50% load | 842 | 1068 | 1155 | 1187 |
| 75% load | 922 | 1153 | 1289 | 1313 |
| 100% load | 979 | 1267 | 1439 | 1501 |

ECO Mode

| UPS rating | 60 kW | 80 kW | 100 kW |
|------------|-------|-------|--------|
| 25% load | 990 | 1123 | 1190 |
| 50% load | 1188 | 1327 | 1490 |
| 75% load | 1419 | 1631 | 1919 |
| 100% load | 1687 | 1988 | 2471 |

eConversion

| UPS rating | 20 kW with N+1 power module | 30 kW with N+1 power module | 40 kW with N+1 power module | 50 kW with N+1 power module |
|------------|-----------------------------|-----------------------------|-----------------------------|-----------------------------|
| 25% load | 947 | 1692 | 1635 | 1633 |
| 50% load | 1000 | 1707 | 1742 | 1757 |
| 75% load | 1036 | 1792 | 1814 | 1890 |
| 100% load | 1101 | 1814 | 1979 | 2099 |

eConversion

| UPS rating | 60 kW | 80 kW | 100 kW |
|------------|-------|-------|--------|
| 25% load | 1415 | 1749 | 1790 |
| 50% load | 1558 | 1971 | 2112 |
| 75% load | 1647 | 2303 | 2560 |
| 100% load | 1862 | 2641 | 3053 |

Battery Operation

| UPS rating | 20 kW with N+1 power module | 30 kW with N+1 power module | 40 kW with N+1 power module | 50 kW with N+1 power module |
|------------|-----------------------------|-----------------------------|-----------------------------|-----------------------------|
| 25% load | 1405 | 2167 | 2400 | 2632 |
| 50% load | 1836 | 2865 | 3330 | 3795 |
| 75% load | 2267 | 3562 | 4260 | 4958 |
| 100% load | 2697 | 4260 | 5191 | 6122 |

Battery Operation

| UPS rating | 60 kW | 80 kW | 100 kW |
|------------|-------|-------|--------|
| 25% load | 2527 | 3203 | 3647 |
| 50% load | 3900 | 5089 | 6141 |
| 75% load | 5463 | 7266 | 9090 |
| 100% load | 7217 | 9734 | 12493 |

208 V UPS

| 10 kW with N+1 power module | Normal operation | | | ECO mode | | |
|-----------------------------|------------------|------|------|----------|-----|-----|
| | 200 | 208 | 220 | 200 | 208 | 220 |
| 25% load | 793 | 802 | 804 | 748 | 728 | 726 |
| 50% load | 1055 | 1049 | 1041 | 781 | 779 | 764 |
| 75% load | 1389 | 1362 | 1326 | 801 | 793 | 782 |
| 100% load | 1781 | 1734 | 1669 | 878 | 864 | 844 |

| 10 kW with N+1 power module | eConversion | | | Battery operation | | |
|-----------------------------|-------------|-----|-----|-------------------|------|------|
| | 200 | 208 | 220 | 200 | 208 | 220 |
| Voltage (V) | 200 | 208 | 220 | 200 | 208 | 220 |
| 25% load | 721 | 706 | 707 | 955 | 953 | 942 |
| 50% load | 727 | 724 | 727 | 1258 | 1242 | 1210 |
| 75% load | 808 | 802 | 792 | 1636 | 1601 | 1543 |
| 100% load | 891 | 877 | 858 | 2091 | 2031 | 1941 |

| 15 kW with N+1 power module | Normal operation | | | ECO mode | | |
|-----------------------------|------------------|------|------|----------|------|------|
| | 200 | 208 | 220 | 200 | 208 | 220 |
| Voltage (V) | 200 | 208 | 220 | 200 | 208 | 220 |
| 25% load | 1243 | 1252 | 1268 | 894 | 898 | 894 |
| 50% load | 1628 | 1623 | 1621 | 948 | 941 | 927 |
| 75% load | 2084 | 2041 | 2034 | 1061 | 1047 | 1028 |
| 100% load | 2556 | 2513 | 2476 | 1186 | 1162 | 1127 |

| 15 kW with N+1 power module | eConversion | | | Battery operation | | |
|-----------------------------|-------------|------|------|-------------------|------|------|
| | 200 | 208 | 220 | 200 | 208 | 220 |
| Voltage (V) | 200 | 208 | 220 | 200 | 208 | 220 |
| 25% load | 1052 | 1059 | 1063 | 1307 | 1290 | 1277 |
| 50% load | 1053 | 1034 | 1022 | 1779 | 1746 | 1707 |
| 75% load | 1158 | 1164 | 1141 | 2260 | 2210 | 2143 |
| 100% load | 1293 | 1284 | 1235 | 2752 | 2682 | 2585 |

| 20 kW with N+1 power module | Normal operation | | | ECO mode | | |
|-----------------------------|------------------|------|------|----------|------|------|
| | 200 | 208 | 220 | 200 | 208 | 220 |
| Voltage (V) | 200 | 208 | 220 | 200 | 208 | 220 |
| 25% load | 1397 | 1389 | 1394 | 951 | 934 | 916 |
| 50% load | 1927 | 1910 | 1906 | 1020 | 1012 | 994 |
| 75% load | 2556 | 2513 | 2476 | 1186 | 1162 | 1127 |
| 100% load | 3323 | 3234 | 3149 | 1383 | 1350 | 1304 |

| 20 kW with N+1 power module | eConversion | | | Battery operation | | |
|-----------------------------|-------------|------|------|-------------------|------|------|
| | 200 | 208 | 220 | 200 | 208 | 220 |
| Voltage (V) | 200 | 208 | 220 | 200 | 208 | 220 |
| 25% load | 1084 | 1083 | 1099 | 1463 | 1441 | 1420 |
| 50% load | 1201 | 1190 | 1174 | 2099 | 2055 | 1997 |
| 75% load | 1293 | 1284 | 1235 | 2752 | 2682 | 2585 |
| 100% load | 1487 | 1457 | 1405 | 3423 | 3323 | 3185 |

| 25 kW with N+1 power module | Normal operation | | | ECO mode | | |
|-----------------------------|------------------|------|------|----------|------|------|
| | 200 | 208 | 220 | 200 | 208 | 220 |
| Voltage (V) | 200 | 208 | 220 | 200 | 208 | 220 |
| 25% load | 1473 | 1481 | 1491 | 963 | 954 | 944 |
| 50% load | 2237 | 2197 | 2177 | 1096 | 1076 | 1049 |
| 75% load | 3117 | 3045 | 2973 | 1336 | 1299 | 1253 |
| 100% load | 4187 | 4049 | 3898 | 1617 | 1564 | 1493 |

| 25 kW with N+1 power module | eConversion | | | Battery operation | | |
|-----------------------------|-------------|------|------|-------------------|------|------|
| | 200 | 208 | 220 | 200 | 208 | 220 |
| 25% load | 1114 | 1114 | 1108 | 1620 | 1593 | 1563 |
| 50% load | 1285 | 1276 | 1229 | 2423 | 2366 | 2290 |
| 75% load | 1441 | 1406 | 1369 | 3254 | 3162 | 3034 |
| 100% load | 1637 | 1627 | 1597 | 4112 | 3978 | 3795 |

| 30 kW | Normal operation | | | ECO mode | | |
|-----------|------------------|------|------|----------|------|------|
| | 200 | 208 | 220 | 200 | 208 | 220 |
| 25% load | 1881 | 1854 | 1797 | 928 | 918 | 904 |
| 50% load | 3067 | 2955 | 2804 | 1100 | 1076 | 1047 |
| 75% load | 4753 | 4510 | 4191 | 1417 | 1370 | 1317 |
| 100% load | 6948 | 6526 | 5948 | 1779 | 1718 | 1636 |

| 30 kW | eConversion | | | Battery operation | | |
|-----------|-------------|------|------|-------------------|------|------|
| | 200 | 208 | 220 | 200 | 208 | 220 |
| 25% load | 933 | 957 | 901 | 1608 | 1576 | 1566 |
| 50% load | 1199 | 1181 | 1148 | 2593 | 2513 | 2441 |
| 75% load | 1490 | 1463 | 1412 | 3752 | 3607 | 3455 |
| 100% load | 1857 | 1802 | 1727 | 5084 | 4859 | 4610 |

| 40 kW | Normal operation | | | ECO mode | | |
|-----------|------------------|------|------|----------|------|------|
| | 200 | 208 | 220 | 200 | 208 | 220 |
| 25% load | 2449 | 2396 | 1908 | 1003 | 994 | 979 |
| 50% load | 4075 | 3897 | 3161 | 1370 | 1323 | 1274 |
| 75% load | 6336 | 5082 | 4829 | 1850 | 1771 | 1680 |
| 100% load | 9308 | 7428 | 6927 | 2435 | 2354 | 2189 |

| 40 kW | eConversion | | | Battery operation | | |
|-----------|-------------|------|------|-------------------|------|------|
| | 200 | 208 | 220 | 200 | 208 | 220 |
| 25% load | 1197 | 1194 | 1304 | 2024 | 1948 | 1910 |
| 50% load | 1516 | 1472 | 1448 | 3366 | 3291 | 3141 |
| 75% load | 1958 | 1906 | 1838 | 4936 | 4711 | 4488 |
| 100% load | 2530 | 2443 | 2311 | 6731 | 6431 | 6133 |

| 50 kW | Normal operation | | | ECO mode | | |
|-----------|------------------|-------|------|----------|------|------|
| | 200 | 208 | 220 | 200 | 208 | 220 |
| 25% load | 2806 | 2735 | 2181 | 1172 | 1140 | 1116 |
| 50% load | 5117 | 4093 | 3936 | 1597 | 1529 | 1470 |
| 75% load | 8491 | 6794 | 6377 | 2292 | 2179 | 2059 |
| 100% load | 13160 | 10339 | 9495 | 3173 | 3029 | 2825 |

| 50 kW | eConversion | | | Battery operation | | |
|----------|-------------|------|------|-------------------|------|------|
| | 200 | 208 | 220 | 200 | 208 | 220 |
| 25% load | 1194 | 1209 | 1193 | 2325 | 2270 | 2196 |
| 50% load | 1730 | 1652 | 1643 | 4121 | 3985 | 3795 |

| 50 kW | eConversion | | | Battery operation | | |
|-------------|-------------|------|------|-------------------|------|------|
| Voltage (V) | 200 | 208 | 220 | 200 | 208 | 220 |
| 75% load | 2396 | 2300 | 2184 | 6275 | 6024 | 5683 |
| 100% load | 3268 | 3128 | 2908 | 8788 | 8385 | 7862 |

Heat Dissipation for Maintenance Bypass Cabinet with Transformer in BTU/hr

| | |
|----------------------|-------------|
| Commercial reference | GVSBPOT100T |
| 100% load | 10600 |

UPS Shipping Weights and Dimensions

| UPS rating | Weight kg (lbs) | Height mm (in) | Width mm (in) | Depth mm (in) |
|---|-----------------|----------------|---------------|---------------|
| 20-50 kW UPS 480 V with N+1 power module* | 250 (551) | 2082 (81.96) | 755 (29.72) | 1010 (39.76) |
| 60-100 kW UPS 480 V without preinstalled battery strings* | 250 (551) | 2082 (81.96) | 755 (29.72) | 1010 (39.76) |
| 60 kW UPS 480 V with three battery strings | 690 (1521) | 2082 (81.96) | 755 (29.72) | 1010 (39.76) |
| 80-100 kW UPS 480 V with three battery strings | 705 (1554) | 2082 (81.96) | 755 (29.72) | 1010 (39.76) |
| 10-25 kW UPS 208 V with N+1 power module* | 250 (551) | 2082 (81.96) | 755 (29.72) | 1010 (39.76) |
| 30-50 kW UPS 208 V without preinstalled battery strings* | 250 (551) | 2082 (81.96) | 755 (29.72) | 1010 (39.76) |
| 30 kW UPS 208 V with three battery strings | 690 (1521) | 2082 (81.96) | 755 (29.72) | 1010 (39.76) |
| 40-50 kW UPS 208 V with three battery strings | 705 (1554) | 2082 (81.96) | 755 (29.72) | 1010 (39.76) |

NOTE: The UPS models marked with an * in the table above are shipped with no power modules preinstalled in the UPS and all power modules shipped separately. Battery strings are not included and must be bought separately.

Power Module Shipping Weights and Dimensions

| Commercial reference | Weight kg (lbs) | Height mm (in) | Width mm (in) | Depth mm (in) |
|----------------------|-----------------|----------------|---------------|---------------|
| GVPM20KD | 48 (106) | 330 (12.99) | 580 (22.83) | 780 (30.70) |
| GVPM50KD | 62 (137) | 330 (12.99) | 580 (22.83) | 780 (30.70) |

Modular Battery Shipping Weights and Dimensions

| Commercial reference | Weight kg (lbs) | Height mm (in) | Width mm (in) | Depth mm (in) |
|----------------------|-----------------|----------------|---------------|---------------|
| GVSBTU | 33 (73) | 180 (7.08) | 150 (5.90) | 800 (31.49) |
| GVSBTULL | 33 (73) | 180 (7.08) | 150 (5.90) | 800 (31.49) |

UPS Weights and Dimensions

| UPS rating | Weight kg (lbs) | Height mm (in) | Width mm (in) | Depth mm (in) |
|---|-----------------|----------------|---------------|---------------|
| 20 kW UPS 480 V with three battery strings ²¹ | 650 (1433) | 1970 (77.56) | 550 (21.65) | 847 (33.35) |
| 30-50 kW UPS 480 V with three battery strings ²¹ | 680 (1500) | 1970 (77.56) | 550 (21.65) | 847 (33.35) |
| 60 kW UPS 480 V with three battery strings | 665 (1466) | 1970 (77.56) | 550 (21.65) | 847 (33.35) |
| 80-100 kW UPS 480 V with three battery strings | 680 (1500) | 1970 (77.56) | 550 (21.65) | 847 (33.35) |
| 10 kW UPS 208 V with three battery strings ²¹ | 650 (1433) | 1970 (77.56) | 550 (21.65) | 847 (33.35) |
| 15-25 kW UPS 208 V with three battery strings ²¹ | 680 (1500) | 1970 (77.56) | 550 (21.65) | 847 (33.35) |
| 30 kW UPS 208 V with three battery strings | 665 (1466) | 1970 (77.56) | 550 (21.65) | 847 (33.35) |
| 40-50 kW UPS 208 V with three battery strings | 680 (1500) | 1970 (77.56) | 550 (21.65) | 847 (33.35) |

NOTE: One battery module weighs approximately 32 kg (70.5 lbs).

Clearance

NOTE: Clearance dimensions are published for airflow and service access only. Consult with the local safety codes and standards for additional requirements in your local area.

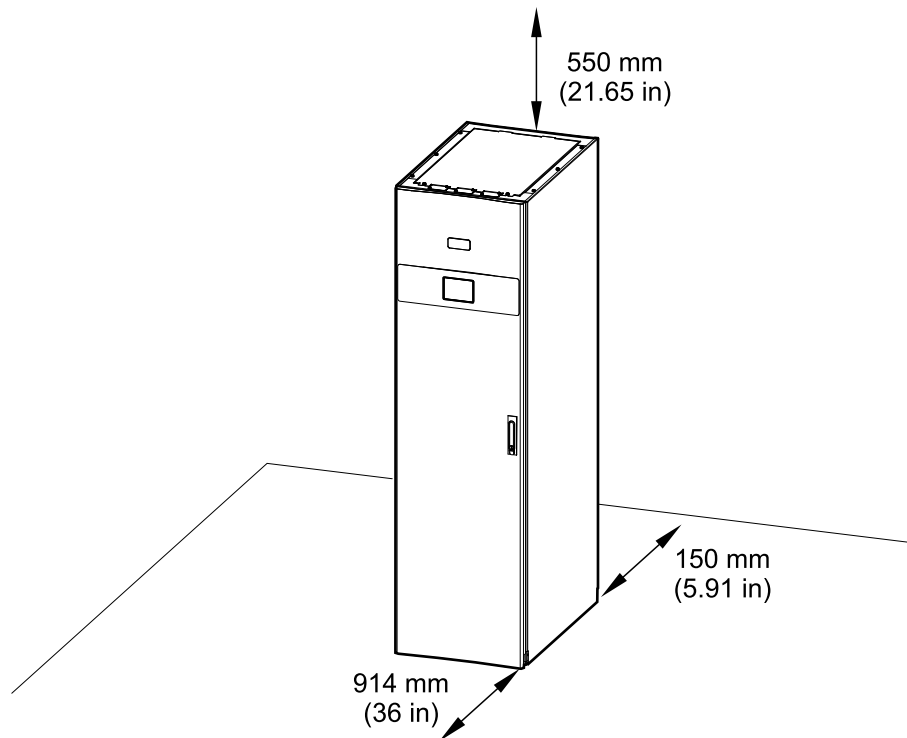

21. UPS model with N+1 power module.

Drawings

NOTE: A comprehensive set of drawings is available on www.se.com.

NOTE: These drawings are for reference ONLY – subject to change without notice.

20-50 kW (N+1 Power Module) and 60-100 kW 480 V UPS 10-25 kW (N+1 Power Module) and 30-50 kW 208 V UPS

SINGLE MAINS (ADJACENT BATTERY)

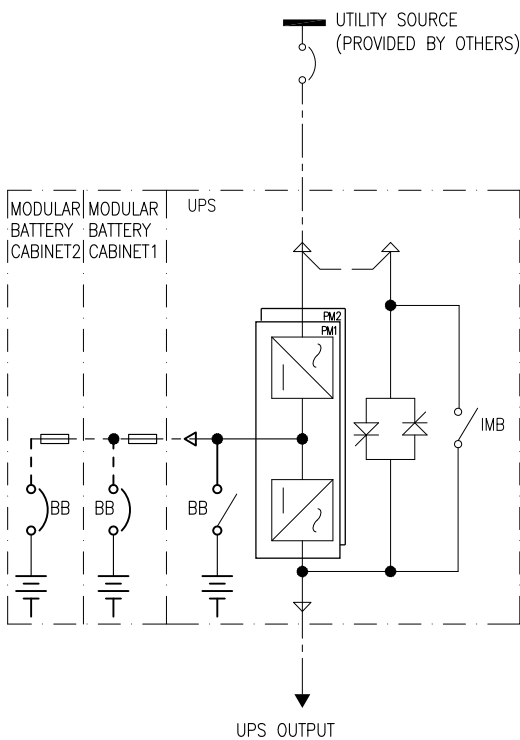

DUAL MAINS (ADJACENT BATTERY)

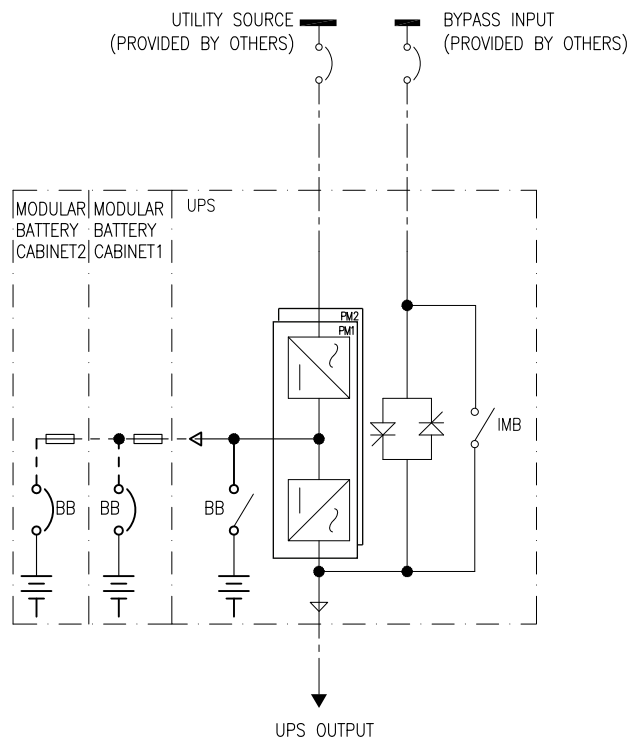

REMOTE BATTERY-TYPICAL
(REST OF CONNECTIONS
SIMILAR TO ADJACENT BATTERY
EXCEPT BELOW)

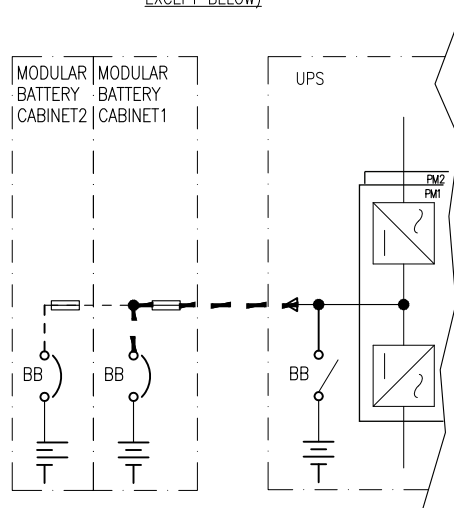

Options

Configuration Options

- eConversion mode
- Compact design, high density technology, and modular architecture
- Internal battery modules
- Single or dual mains
- Up to 4+0 UPSs in parallel for capacity
- Up to 3+1 UPSs in parallel for redundancy
- Rear cable entry
- EcoStruxure IT compatible
- Generator compatible
- Touchscreen LCD
- Replacement of power module in any operation mode (Live Swap)²²
- ECO mode

22. In all systems configured for Live Swap.

Hardware Options

See Weights and Dimensions for Options, page 135.

NOTE: All hardware options listed here may not be available in all regions.

Power Module

- Power module 50 kW 480 V/25 kW 208 V (GVPM50KD)
- Power module 20 kW 480 V/10 kW 208 V (GVPM20KD)

Modular Battery Cabinet

Modular battery cabinet including battery breaker.

- Modular battery cabinet for up to six smart modular battery strings (GVSMODBC6)
- Modular battery cabinet for up to nine smart modular battery strings (GVSMODBC9)

Maintenance Bypass Cabinet

Maintenance bypass cabinet for complete isolation of the UPS during service operations. Only for single UPS. Single mains as standard, can be installed as dual mains with optional SSIB kit GVSOPT031.

- 60-100 kW 480 V maintenance bypass cabinet (GVSBP100T)

Maintenance Bypass Cabinet with Output Transformer

Maintenance bypass cabinet with output transformer for complete isolation of the UPS during service operations. Only for single 480 V UPS.

- 60-100 kW, 480 V in, 208 V out, maintenance bypass cabinet with output transformer (GVSBPOT100T)

Maintenance Bypass Panel

Maintenance bypass panel for complete isolation of the UPS during service operations. Only for single UPS.

- 10-30 kW 208 V, 20-60 kW 480 V maintenance bypass panel (GVSBPSU60G-WP)
- 25-50 kW 208 V, 50-100 kW 480 V maintenance bypass panel (GVSBPSU100G-WP)

Remote Alarm Panel

- Remote alarm panel (GVSOPT036)

Optional Installation Kits

- Seismic kit for UPS (GVSOPT016)
- Parallel kit for UPS (GVSOPT006)
- NEMA 2 hole lug kit (GVSOPT020)
- SSIB kit for dual mains maintenance bypass cabinet (GVSOPT031)

- Live Swap kit for the UPS (GVSOPT039)

Optional Network Management Card

- Network Management Card LCES2 with Modbus, Ethernet and AUX sensors (AP9644)

Air Filter

- Air filter kit (GVSOPT014)

Battery Modules

9 Ah smart high capacity battery modules. This battery module type is delivered for UPS models with preinstalled battery strings.

- Galaxy VS 9 Ah Smart High Capacity Battery Module (GVSBTU)
- Galaxy VS 9 Ah Smart Modular High Capacity Battery String (GVSBT4)

9 Ah smart long-life high capacity battery modules. For this battery module type, select a UPS models without preinstalled battery strings.

- Galaxy VS 9 Ah Smart Long-Life High Capacity Battery Module (GVSBTULL)
- Galaxy VS 9 Ah Smart Modular Long-Life High Capacity Battery String (GVSBT4LL)

NOTE: Always use the same battery module type in the UPS system. Do not mix different battery module types.

UPS with Input Isolation Transformer and Up to 3 Internal Battery Strings

Single System Overview

| | |
|-----|---|
| UIB | Unit input breaker |
| IMB | Internal maintenance breaker |
| UOB | Unit output breaker |
| BB | Battery breaker in UPS for internal batteries |

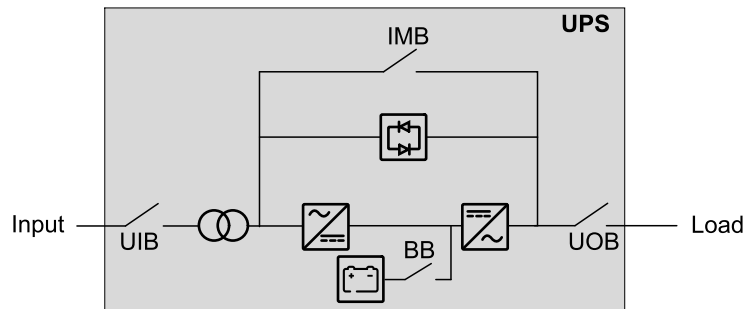

Inverter Short Circuit Capabilities (Bypass not Available)

IK1 – Short Circuit between a Phase and Neutral

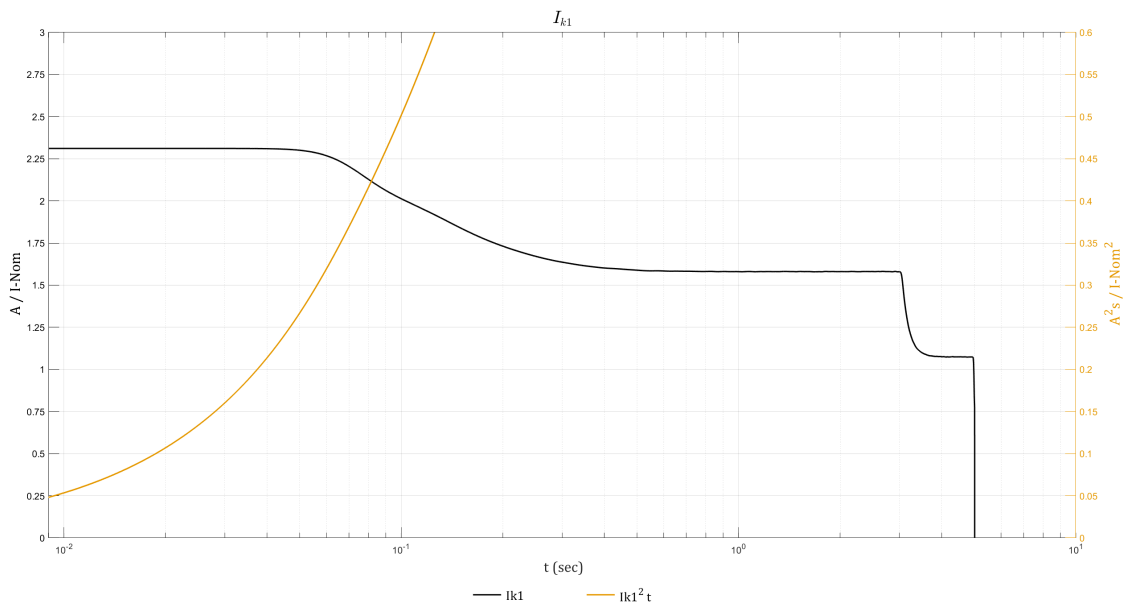

IK1 400 V

| S [kVA] | 10ms; I[A]/I ² t [A ² t] | 20ms; I[A]/I ² t [A ² t] | 30ms; I[A]/I ² t [A ² t] | 100ms; I[A]/I ² t [A ² t] | 1s; I[A]/I ² t [A ² t] |
|---------|--|--|--|---|--|
| 20 | 67 / 45 | 67 / 89 | 67 / 134 | 58 / 418 | 46 / 2411 |

IK2 – Short Circuit between Two Phases

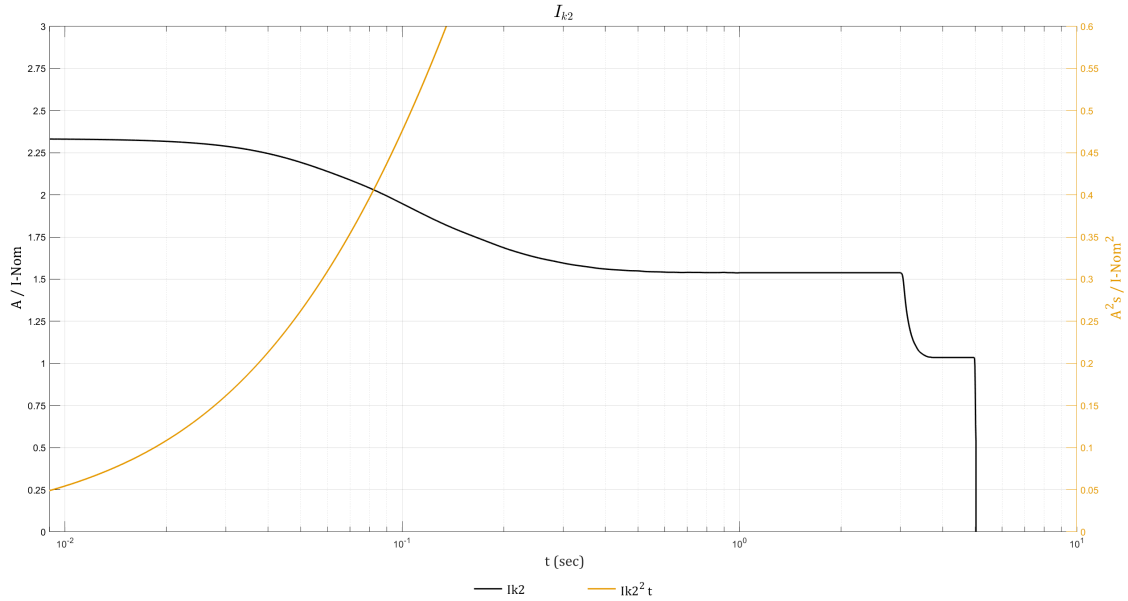

IK2 400 V

| S [kVA] | 10ms; I[A]/I ² t [A ² t] | 20ms; I[A]/I ² t [A ² t] | 30ms; I[A]/I ² t [A ² t] | 100ms; I[A]/I ² t [A ² t] | 1s; I[A]/I ² t [A ² t] |
|---------|--|--|--|---|--|
| 20 | 67 / 45 | 67 / 90 | 67 / 135 | 56 / 397 | 44 / 2284 |

IK3 – Short Circuit between Three Phases

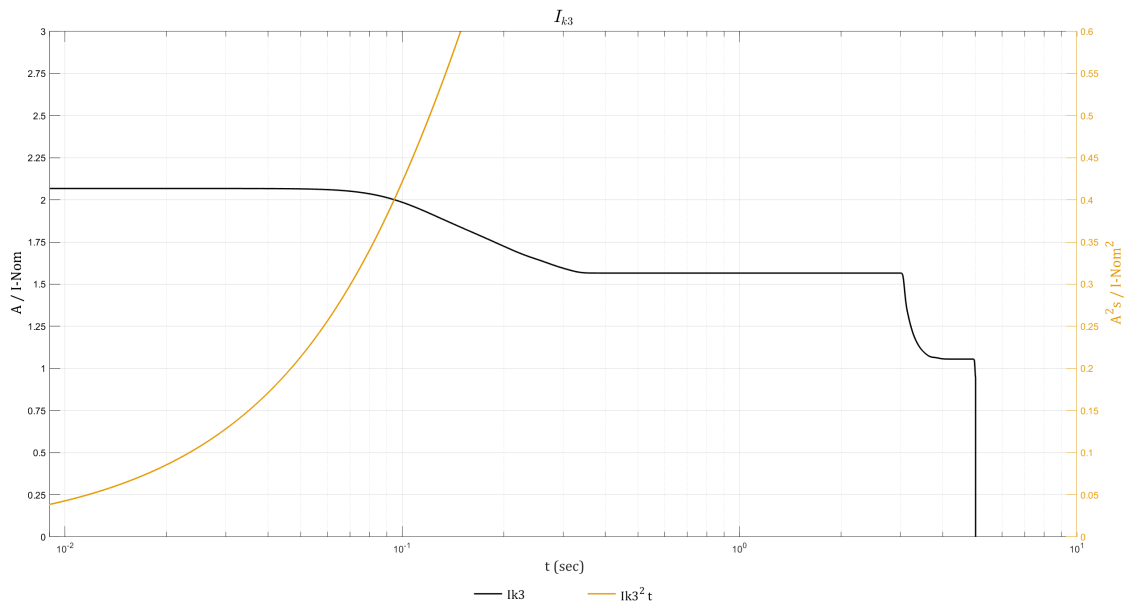

IK3 400 V

| S [kVA] | 10ms; I[A]/I ² t [A ² t] | 20ms; I[A]/I ² t [A ² t] | 30ms; I[A]/I ² t [A ² t] | 100ms; I[A]/I ² t [A ² t] | 1s; I[A]/I ² t [A ² t] |
|---------|--|--|--|---|--|
| 20 | 60 / 36 | 60 / 71 | 60 / 107 | 57 / 351 | 45 / 2294 |

Efficiency

| 20 kW | Normal operation | Battery operation |
|--------------|-------------------------|--------------------------|
| 25% load | 90.1% | 92.4% |
| 50% load | 92.1% | 94.9% |
| 75% load | 93.2% | 95.8% |
| 100% load | 93.8% | 96.2% |

Derating Due to Load Power Factor

0.7 leading to 0.7 lagging without derating.

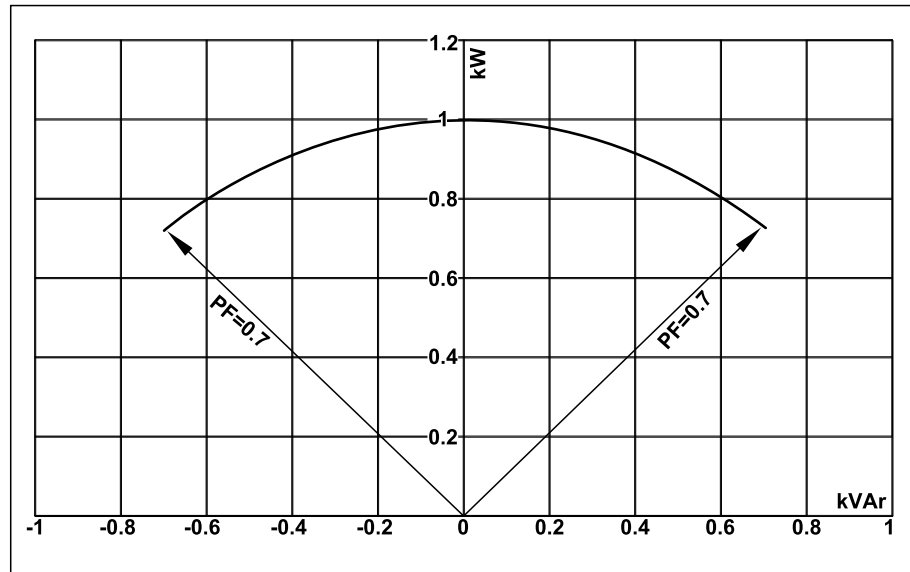

| UPS rating | UPS output | | | | | |
|------------|----------------|----------------|----------------|----------------|----------------|----------------|
| | Lagging | | | Leading | | |
| PF=1 | PF=0.7 | PF=0.8 | PF=0.9 | PF=0.9 | PF=0.8 | PF=0.7 |
| 20 kVA/kW | 20 kVA / 14 kW | 20 kVA / 16 kW | 20 kVA / 18 kW | 20 kVA / 18 kW | 20 kVA / 16 kW | 20 kVA / 14 kW |

Batteries

End of Discharge Voltage

The voltage is 1.6 to 1.75 per cell depending on discharge ratio.

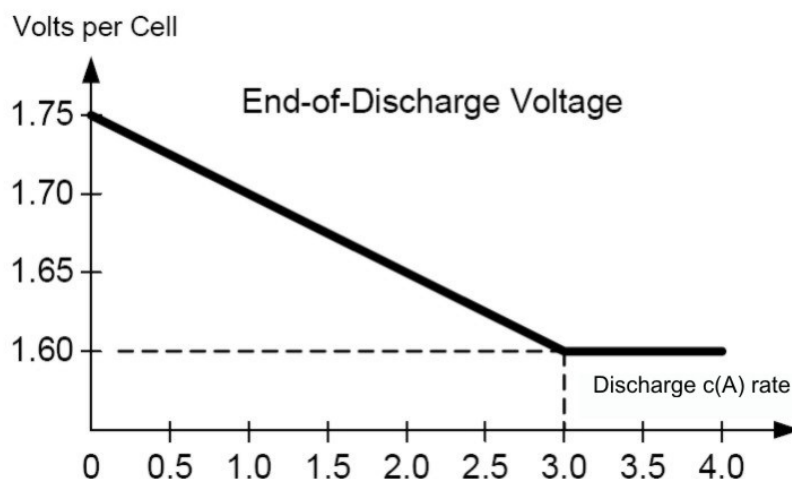

Battery Voltage Window

| | Boost 2.38 Vpc | Nominal 2.0 Vpc | Minimum 1.6 Vpc |
|---------------------|----------------|-----------------|-----------------|
| Battery voltage (V) | 571.2 | 480 | 384 |

Battery Runtimes in Minutes

NOTE: Runtimes are given at power factor 1 with 100% load.

NOTE: The 20 kW input isolation transformer is not active when the UPS is in battery operation. The potential runtimes can therefor exceed the time limitations in overload capacity of the UPS when in normal operation.

| UPS rating | 20 kW | 30 kW | 40 kW | 50 kW |
|-----------------------------------|-------|-------|-------|-------|
| Number of modular battery strings | | | | |
| 1 | NA | NA | NA | NA |
| 2 | 11.0 | 6.0 | NA | NA |
| 3 | 18.5 | 10.5 | 7.3 | 5.2 |

Compliance

| | |
|-------------|--|
| Safety | UL 1778 5th edition |
| EMC/EMI/RFI | FCC Part 15 Subpart B, Class A |
| Seismic | ICC-ES AC 156 (2015): OHSPD Pre-approved; Sds=1.54 g for z/h=1 and Sds=1.63 g for z/h=0; Ip= 1.5 |

Communication and Management

| | |
|---------------------------|---|
| Local area network | 1 Gbps – 1 port as default |
| Modbus | Modbus (SCADA) |
| Output relays | 4 x SELV preconfigured from factory for use with remote alarm panel (GVSOPT036). Can be reconfigured if no remote alarm panel is present in the installation. |
| Input contacts | 3 x SELV configurable, 1 x SELV preconfigured from factory (input contact 1 reserved for input isolation transformer overtemperature) |
| Standard control panel | 4.3 inch touchscreen display |
| Audible alarm | Yes |
| Emergency Power Off (EPO) | Normally Closed (NC), used Internal 24 VDC SELV |
| External switchgear | MBB |
| External synchronization | No |
| Battery monitoring | Available for modular batteries |

EPO

EPO Configuration – Normally Closed (NC) Connection

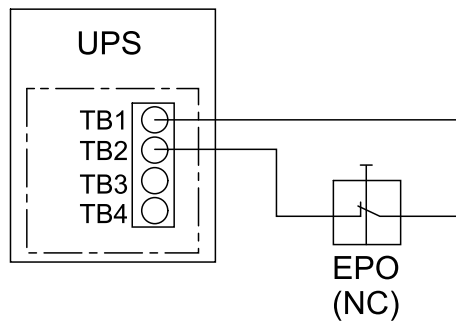

The EPO input supports 24 VDC.

NOTE: The default setting for the EPO activation is to turn off the inverter. If you want the EPO activation to transfer the UPS into forced static bypass operation instead, please contact Schneider Electric.

Configurable Input Contacts and Output Relays

Input Contacts

Four input contacts are available. Three input contacts can be configured to indicate a given event via the display. The input contacts support 24 VDC 10 mA. All circuits connected must have the same 0 V reference.

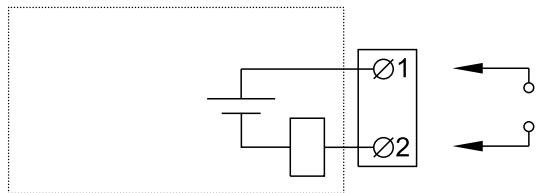

| Name | Description | Location | Alarm text on UPS display |
|------------------------|--|------------------------------|--|
| IN_1 (input contact 1) | Preconfigured input contact (reserved for input isolation transformer overtemperature) | 640-4864 terminal J6616, 1-2 | Transformer temperature is too high |
| IN_2 (input contact 2) | Configurable input contact | 640-4864 terminal J6616, 3-4 | |
| IN_3 (input contact 3) | Configurable input contact | 640-4864 terminal J6616, 5-6 | |
| IN_4 (input contact 4) | Configurable input contact | 640-4864 terminal J6616, 7-8 | |

Output Relays

The output relays are preconfigured for use with the remote alarm panel GVSOPT036. If the remote alarm panel is not part of the installation, the output relays can be reconfigured for other functions – see the operation manual. The output relays support 24 VAC/VDC 1 A. All external circuitry must be fused with maximum 1 A fast acting fuses.

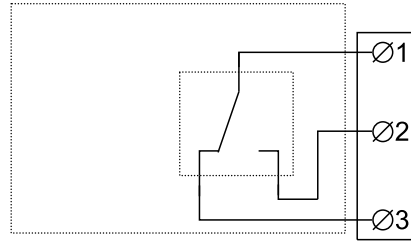

| Name | Description | Location | Alarm text on UPS display | Corresponding lamp on remote alarm panel |
|------------------------|----------------------------|--------------------------------|---------------------------------|--|
| OUT_1 (output relay 1) | Preconfigured output relay | 640-4864 terminal J6617, 1-3 | UPS in normal operation | UPS ONLINE |
| OUT_2 (output relay 2) | Preconfigured output relay | 640-4864 terminal J6617, 4-6 | UPS common alarm | UPS General Alarm |
| OUT_3 (output relay 3) | Preconfigured output relay | 640-4864 terminal J6617, 7-9 | UPS in battery operation | UPS on Battery |
| OUT_4 (output relay 4) | Preconfigured output relay | 640-4864 terminal J6617, 10-12 | Battery voltage low | UPS Low Battery |

Specifications

Specifications for 20 kW UPS with Input Isolation Transformer and Internal Batteries

The UPS includes an input isolation transformer of 480 V In, 400 V Out. The UPS is designed for a continuous 20 kW load (transformer sized at 20 kW) and supports short-term peak loads up to 80 kW. The UPS protects medical equipment (e.g. X-ray, scanners) or other load equipment with similar short-time peak consumption.

| | | |
|-------------------|----------------------------------|--|
| Input 480 V | Connections | 3-wire (L1, L2, L3, G) |
| | Input voltage range (V) | 432-528 |
| | Frequency (Hz) | 60 |
| | Nominal input current (A) | 29 |
| | Maximum input current (A) | 34 |
| | Input current limitation (A) | 80 |
| | Total harmonic distortion (THDI) | <6% at 100% load |
| | Input power factor | 0.99 at 100% load |
| | Protection | Built-in backfeed protection and fuses |
| | Maximum short circuit rating | 20 kA RMS |
| | Ramp-in | Programmable and adaptive 1-40 seconds |
| Output 400 V | Connections | 4-wire (L1, L2, L3, N, G) |
| | Output voltage regulation | Symmetrical load $\pm 1\%$ Asymmetrical load $\pm 3\%$ |
| | Overload capacity | 20 kW load: continuous in normal operation and battery operation NOTE: Overload capacities above 20 kW are given with load switching between 100 milliseconds ON and 200 milliseconds OFF. 30 kW load: 120 minutes in normal operation 40 kW load: 60 minutes in normal operation 50 kW load: 45 minutes in normal operation 60 kW load: 30 minutes in normal operation 70 kW load: 20 minutes in normal operation 80 kW load: 5 minutes in normal operation |
| | Dynamic load response | $\pm 5\%$ |
| | Output power factor | 1 |
| | Nominal output current (A) | 29 |
| | Output frequency (Hz) | 60 Hz bypass synchronized – 60 Hz $\pm 0.1\%$ free-running |
| | Synchronized slew rate (Hz/sec) | Programmable to 0.25, 0.5, 1, 2, 4, 6 |
| | Total harmonic distortion (THDU) | <1% for linear load <5% for non-linear load |
| | Load crest factor | 2.5 |
| Load power factor | 0.7 leading to 0.7 lagging | |

| | | |
|----------------------|--|--|
| Battery 400 V | Charging power in % of output power at 0-40% load | 80% |
| | Charging power in % of output power at 100% load | 20% |
| | Maximum charging power (at 0-40% load) (kW) | 16 |
| | Maximum charging power (at 100% load) (kW) | 4 |
| | Nominal battery voltage (VDC) | 480 |
| | Nominal float voltage (VDC) | 545 |
| | Maximum boost voltage (VDC) | 572 |
| | Temperature compensation (per cell) | -3.3mV/°C, for T ≥ 25 °C – 0mV/°C, for T < 25 °C |
| | End of discharge voltage (full load) (VDC) | 384 |
| | Battery current at full load and nominal battery voltage (A) | 43 |
| | Battery current at full load and minimum battery voltage (A) | 54 |
| | Ripple current | < 5% C20 (5-minute runtime) |
| | Battery test | Manual/automatic (selectable) |
| | Maximum short circuit rating | 10 kA |

Recommended Cable Sizes

⚠️ ⚠️ DANGER

HAZARD OF ELECTRIC SHOCK, EXPLOSION, OR ARC FLASH

All wiring must comply with all applicable national and/or electrical codes. The maximum allowable cable size is 2 AWG.

Failure to follow these instructions will result in death or serious injury.

Cable sizes in this manual are based on Table 310.15 (B)(16) of the National Electrical Code (NEC) with the following assertions:

- 90 °C (194 °F) conductors (75 °C (167 °F) termination)
- An ambient temperature of 30 °C (86 °F)
- Use of copper conductors
- Installation method C

If the ambient temperature is greater than 30 °C (86 °F), larger conductors are to be selected in accordance with the correction factors of the NEC.

Equipment grounding conductors are sized in accordance with NEC Article 250.122 and Table 250.122.

| | |
|---------------------|-------|
| Input/output phases | 2 AWG |
| Input/output EGC | 2 AWG |
| Neutral | 2 AWG |

Recommended Bolt and Lug Sizes

| Cable size | Bolt size | Cable lug type | Crimping tool | Die |
|------------|-----------|----------------|---------------|--------------------|
| 2 AWG | M8 x 25 | LCA2-56-Q | CT-720 | CD-720-1 Brown P33 |

Recommended Upstream Protection

⚠ CAUTION

HAZARD OF FIRE

- Connect only to a circuit with the below specifications.
- Connect to a circuit provided with a 125 A branch circuit overcurrent protection maximum in accordance with the National Electrical Code, ANSI/NFPA70, and the Canadian Electrical Code, Part I, C22.1.

Failure to follow these instructions can result in injury or equipment damage.

| | |
|--------------|----------|
| UPS rating | 20 kW |
| Breaker type | HDL36125 |

Torque Specifications

| Bolt size | Torque |
|-----------|-------------------------------------|
| M4 | 1.7 Nm (1.25 lb-ft / 15 lb-in) |
| M5 | 2.2 Nm (1.62 lb-ft / 19.5 lb-in) |
| M6 | 5 Nm (3.69 lb-ft / 44.3 lb-in) |
| M8 | 17.5 Nm (12.91 lb-ft / 154.9 lb-in) |
| M10 | 30 Nm (22 lb-ft / 194.7 lb-in) |
| M12 | 50 Nm (36.87 lb-ft / 442.5 lb-in) |

Environment

| | Operating | Storage |
|--|---|--|
| Temperature | 0 °C to 40 °C (32 °F to 104 °F) | -15 °C to 40 °C (5 °F to 104 °F) for systems with batteries. |
| Relative humidity | 0 - 95% non-condensing | 10 - 80% non-condensing |
| Elevation | Designed for operation in 0-3000 m (0-10000 feet) elevation. Power derating required from 1000-3000 m (3300-10000 feet): Up to 1000 m (3300 feet): 1.000 Up to 1500 m (5000 feet): 0.975 Up to 2000 m (6600 feet): 0.950 Up to 2500 m (8300 feet): 0.925 Up to 3000 m (10000 feet): 0.900 | |
| Audible noise one meter (three feet) from unit | 57 dB at 70% load, 65 dB at 100% load | |
| Protection class | IP20 | |
| Color | RAL 9003, gloss level 85% | |

Heat Dissipation in BTU/hr

| 20 kW | Normal operation | Battery operation |
|-----------|------------------|-------------------|
| 25% load | <3000 | 1405 |
| 50% load | <3000 | 1836 |
| 75% load | <3000 | 2267 |
| 100% load | <3000 | 2697 |

UPS Shipping Weights and Dimensions

| UPS rating | Weight kg (lbs) | Height mm (in) | Width mm (in) | Depth mm (in) |
|--|-----------------|----------------|---------------|---------------|
| 20 kW UPS with input isolation transformer and three battery strings | 902 (1989) | 2082 (81.96) | 755 (29.72) | 1010 (39.76) |

Modular Battery Shipping Weights and Dimensions

| Commercial reference | Weight kg (lbs) | Height mm (in) | Width mm (in) | Depth mm (in) |
|----------------------|-----------------|----------------|---------------|---------------|
| GVSBTHULL | 33 (73) | 180 (7.08) | 150 (5.90) | 800 (31.49) |

UPS Weights and Dimensions

| UPS rating | Weight kg (lbs) | Height mm (in) | Width mm (in) | Depth mm (in) |
|--|-----------------|----------------|---------------|---------------|
| 20 kW UPS with input isolation transformer and three battery strings | 877 (1933) | 1970 (77.56) | 550 (21.65) | 847 (33.35) |

NOTE: One battery module weighs approximately 32 kg (70.5 lbs).

Clearance

Required Ventilation Clearance

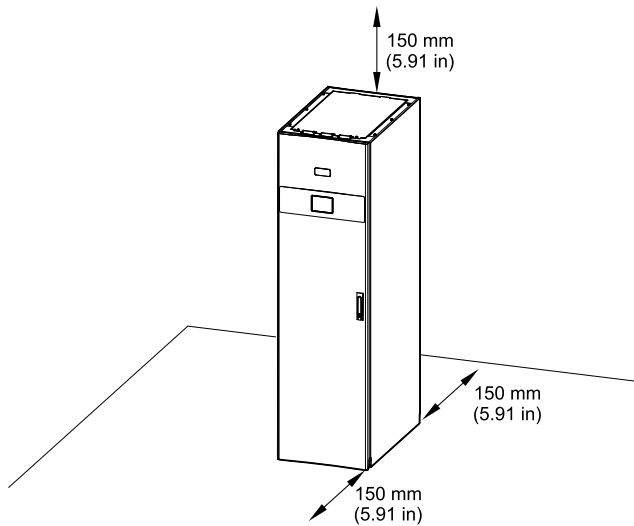

NOTE: These clearance dimensions are published for airflow only. Consult with the local safety codes and standards for additional requirements in your local area.

Recommended Installation and Service Clearance

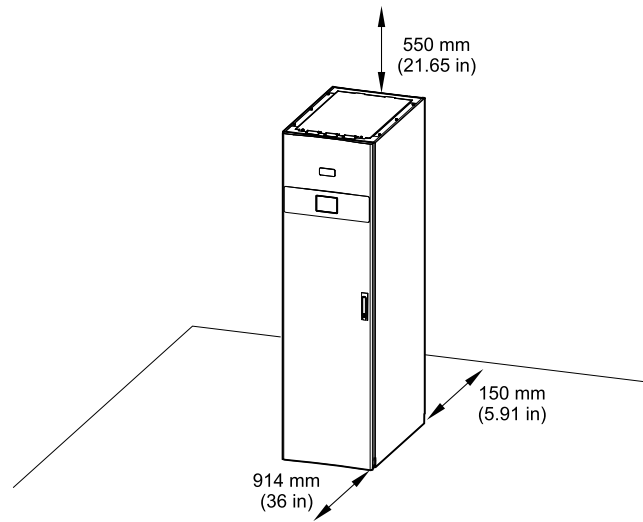

NOTE: These clearance dimensions are published for installation and service access only. Consult with the local safety codes and standards for additional requirements in your local area.

Drawings

NOTE: A comprehensive set of drawings is available on www.se.com.

NOTE: These drawings are for reference ONLY – subject to change without notice.

20 kW UPS with Input Isolation Transformer (480 V In 400 V Out)

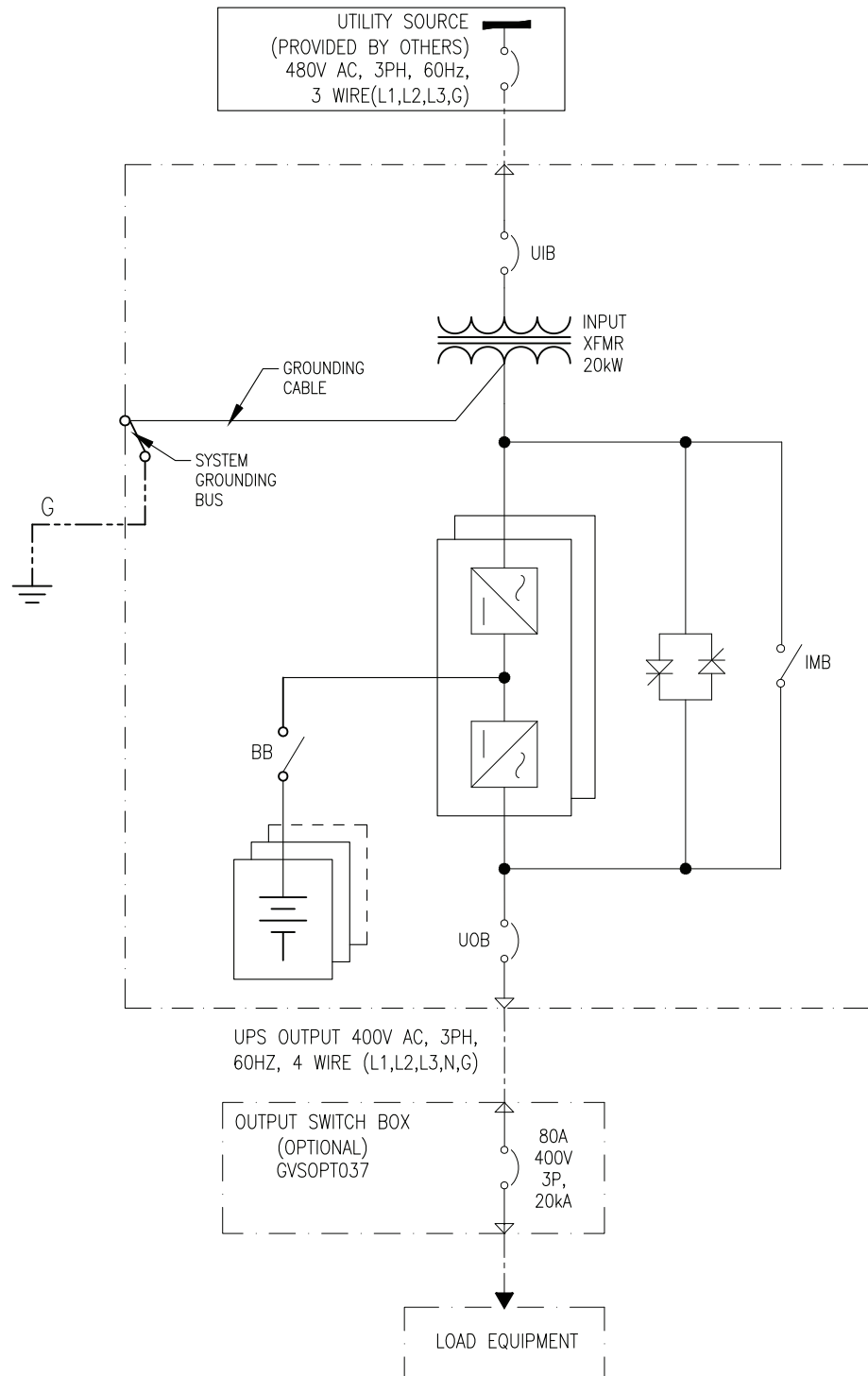

Options

Configuration Options

- Compact design, high density technology, and modular architecture
- Internal battery modules
- Top or bottom cable entry
- EcoStruxure IT compatible
- Generator compatible
- Touchscreen LCD

Hardware Options

See [Weights and Dimensions for Options](#), page 135.

NOTE: All hardware options listed here may not be available in all regions.

Power Module

- Power module 50 kW 480 V (GVPM50KD)

Remote Alarm Panel

- Remote alarm panel (GVSOPT036)

Output Switch Box

- Output switch box with 80 A switch (GVSOPT037)

Optional Installation Kits

- Seismic kit for UPS (GVSOPT016)

Optional Network Management Card

- Network Management Card LCES2 with Modbus, Ethernet and AUX sensors (AP9644)

Air Filter

- Air filter kit (GVSOPT014)

Battery Modules

9 Ah smart long-life high capacity battery modules.

- Galaxy VS 9 Ah Smart Long-Life High Capacity Battery Module (GVSBTHULL)
- Galaxy VS 9 Ah Smart Modular Long-Life High Capacity Battery String (GVSBTH4LL)

Weights and Dimensions for Options

NOTE: Not all options listed here are available for all UPS models. Refer to the hardware options list for the relevant UPS model.

Maintenance Bypass Cabinet Shipping Weights and Dimensions

| Commercial reference | Weight kg (lbs) | Height mm (in) | Width mm (in) | Depth mm (in) |
|----------------------|-----------------|----------------|---------------|---------------|
| GVSBPSU80G | 125 (275.58) | 1660 (65.35) | 635 (25) | 990 (38.98) |
| GVSBP100T | 210 (462.97) | 2096 (82.51) | 818.5 (32.22) | 1008 (39.68) |

Maintenance Bypass Cabinet Weights and Dimensions

| Commercial reference | Weight kg (lbs) | Height mm (in) | Width mm (in) | Depth mm (in) |
|----------------------|-----------------|----------------|---------------|---------------|
| GVSBPSU80G | 110 (242.51) | 1485 (58.46) | 318 (12.52) | 850 (33.46) |
| GVSBP100T | 195 (429.9) | 1970 (77.56) | 600 (23.62) | 847 (33.35) |

Maintenance Bypass Cabinet with Transformer Shipping Weights and Dimensions

| Commercial reference | Weight kg (lbs) | Height mm (in) | Width mm (in) | Depth mm (in) |
|----------------------|-----------------|----------------|---------------|---------------|
| GVSBPIT25B | 425 (936.97) | 1670 (65.75) | 800 (31.5) | 990 (39.98) |
| GVSBPOT50B | 560 (1234.59) | 1670 (65.75) | 800 (31.5) | 990 (39.98) |
| GVSBPOT100T | 725 (1598.35) | 2096 (82.51) | 818.5 (32.22) | 1008 (39.68) |

Maintenance Bypass Cabinet with Transformer Weights and Dimensions

| Commercial reference | Weight kg (lbs) | Height mm (in) | Width mm (in) | Depth mm (in) |
|----------------------|-----------------|----------------|---------------|---------------|
| GVSBPIT25B | 395 (870.83) | 1485 (58.46) | 600 (23.62) | 836 (32.91) |
| GVSBPOT50B | 530 (1168.45) | 1485 (58.46) | 600 (23.62) | 836 (32.91) |
| GVSBPOT100T | 710 (1565.28) | 1970 (77.56) | 600 (23.62) | 847 (33.35) |

Maintenance Bypass Panel Shipping Weights and Dimensions

| Commercial reference | Weight kg (lbs) | Height mm (in) ²³ | Width mm (in) | Depth mm (in) ²³ |
|----------------------|-----------------|------------------------------|---------------|-----------------------------|
| GVSBP60G-WP | 40 (88.18) | 480 (18.89) | 800 (31.49) | 1200 (47.24) |
| GVSBP100G-WP | 100 (220.46) | 580 (22.83) | 1000 (39.37) | 1200 (47.24) |

Maintenance Bypass Panel Weights and Dimensions

| Commercial reference | Weight kg (lbs) | Height mm (in) | Width mm (in) | Depth mm (in) |
|----------------------|-----------------|----------------|---------------|---------------|
| GVSBP60G-WP | 28 (61.73) | 650 (25.59) | 600 (23.62) | 220 (8.66) |
| GVSBP100G-WP | 84 (185.19) | 1000 (39.37) | 850 (33.46) | 280 (11.02) |

Modular Battery Cabinet Shipping Weights and Dimensions

| Commercial reference | Weight kg (lbs) | Height mm (in) | Width mm (in) | Depth mm (in) |
|----------------------|-----------------|----------------|---------------|---------------|
| GVSMODBC6 | 175 (385.8) | 1664 (65.51) | 635 (25) | 990 (38.97) |
| GVSMODBC9 | 206 (454.15) | 2082 (81.96) | 755 (29.72) | 1010 (39.76) |

NOTE: The modular battery cabinet is shipped without battery strings installed.

Modular Battery Cabinet Weights and Dimensions

| Commercial reference | Weight kg (lbs) | Height mm (in) | Width mm (in) | Depth mm (in) |
|---|-------------------------------|----------------|---------------|---------------|
| GVSMODBC6 – Empty – With six battery strings | 145 (319.67) 913 (2012.82) | 1485 (58.46) | 521 (20.51) | 847 (33.35) |
| GVSMODBC9 – Empty – With nine battery strings | 186 (410) 1338 (2950) | 1970 (77.56) | 550 (21.65) | 847 (33.35) |

NOTE: One battery module weighs approximately 32 kg (70.5 lbs).

Output Switch Box Shipping Weights and Dimensions

| Commercial reference | Weight kg (lbs) | Height mm (in) | Width mm (in) | Depth mm (in) |
|----------------------|-----------------|----------------|---------------|---------------|
| GVSOPT037 | 19 (42) | 763 (30.03) | 440 (17.32) | 366 (14.40) |

²³ The product is packaged in a horizontal position, so the shipping height and depth dimensions differ from the product itself.

Output Switch Box Weights and Dimensions

| Commercial reference | Weight kg (lbs) | Height mm (in) | Width mm (in) | Depth mm (in) |
|----------------------|-----------------|----------------|---------------|---------------|
| GVSOPT037 | 14 (31) | 600 (23.62) | 300 (11.81) | 160 (6.29) |

Remote Alarm Panel Shipping Weights and Dimensions

| Commercial reference | Weight kg (lbs) | Height mm (in) | Width mm (in) | Depth mm (in) |
|----------------------|-----------------|----------------|---------------|---------------|
| GVSOPT036 | 19 (42) | 581 (22.87) | 468 (18.42) | 366 (14.40) |

Remote Alarm Panel Weights and Dimensions

| Commercial reference | Weight kg (lbs) | Height mm (in) | Width mm (in) | Depth mm (in) |
|----------------------|-----------------|----------------|---------------|---------------|
| GVSOPT036 | 14 (31) | 400 (15.74) | 300 (11.81) | 178 (7.00) |

Limited Factory Warranty

One-Year Factory Warranty

The limited warranty provided by Schneider Electric in this Statement of Limited Factory Warranty applies only to products you purchase for your commercial or industrial use in the ordinary course of your business.

Terms of Warranty

Schneider Electric warrants that the product shall be free from defects in materials and workmanship for a period of one year from the date of product start-up when start-up is performed by Schneider Electric-authorized service personnel and occurs within six months of the Schneider Electric shipment date. This warranty covers repairing or replacing any defective parts including on-site labor and travel. In the event that the product fails to meet the foregoing warranty criteria, the warranty covers repairing or replacing defective parts at the sole discretion of Schneider Electric for a period of one year from the shipment date. For Schneider Electric cooling solutions, this warranty does not cover circuit breaker resetting, loss of refrigerant, consumables, or preventive maintenance items. Repair or replacement of a defective product or part thereof does not extend the original warranty period. Any parts furnished under this warranty may be new or factory-remanufactured.

Non-transferable Warranty

This warranty is extended to the first person, firm, association or corporation (herein referred to by "You" or "Your") for whom the Schneider Electric product specified herein has been purchased. This warranty is not transferable or assignable without the prior written permission of Schneider Electric.

Assignment of Warranties

Schneider Electric will assign you any warranties which are made by manufacturers and suppliers of components of the Schneider Electric product and which are assignable. Any such warranties are assigned "AS IS" and Schneider Electric makes no representation as to the effectiveness or extent of such warranties, assumes no responsibility for any matters which may be warranted by such manufacturers or suppliers and extends no coverage under this Warranty to such components.

Drawings, Descriptions

Schneider Electric warrants for the warranty period and on the terms of the warranty set forth herein that the Schneider Electric product will substantially conform to the descriptions contained in the Schneider Electric Official Published Specifications or any of the drawings certified and agreed to by contract with Schneider Electric if applicable thereto ("Specifications"). It is understood that the Specifications are not warranties of performance and not warranties of fitness for a particular purpose.

Exclusions

Schneider Electric shall not be liable under the warranty if its testing and examination disclose that the alleged defect in the product does not exist or was caused by end user or any third person misuse, negligence, improper installation or testing. Further, Schneider Electric shall not be liable under the warranty for unauthorized attempts to repair or modify wrong or inadequate electrical voltage

or connection, inappropriate on-site operation conditions, corrosive atmosphere, repair, installation, start-up by non-Schneider Electric designated personnel, a change in location or operating use, exposure to the elements, Acts of God, fire, theft, or installation contrary to Schneider Electric recommendations or specifications or in any event if the Schneider Electric serial number has been altered, defaced, or removed, or any other cause beyond the range of the intended use.

THERE ARE NO WARRANTIES, EXPRESS OR IMPLIED, BY OPERATION OF LAW OR OTHERWISE, OF PRODUCTS SOLD, SERVICED OR FURNISHED UNDER THIS AGREEMENT OR IN CONNECTION HEREWITH. SCHNEIDER ELECTRIC DISCLAIMS ALL IMPLIED WARRANTIES OF MERCHANTABILITY, SATISFACTION AND FITNESS FOR A PARTICULAR PURPOSE. SCHNEIDER ELECTRIC EXPRESS WARRANTIES WILL NOT BE ENLARGED, DIMINISHED, OR AFFECTED BY AND NO OBLIGATION OR LIABILITY WILL ARISE OUT OF, SCHNEIDER ELECTRIC RENDERING OF TECHNICAL OR OTHER ADVICE OR SERVICE IN CONNECTION WITH THE PRODUCTS. THE FOREGOING WARRANTIES AND REMEDIES ARE EXCLUSIVE AND IN LIEU OF ALL OTHER WARRANTIES AND REMEDIES. THE WARRANTIES SET FORTH ABOVE CONSTITUTE SCHNEIDER ELECTRIC SOLE LIABILITY AND PURCHASER'S EXCLUSIVE REMEDY FOR ANY BREACH OF SUCH WARRANTIES. SCHNEIDER ELECTRIC WARRANTIES RUN ONLY TO PURCHASER AND ARE NOT EXTENDED TO ANY THIRD PARTIES.

IN NO EVENT SHALL SCHNEIDER ELECTRIC, ITS OFFICERS, DIRECTORS, AFFILIATES OR EMPLOYEES BE LIABLE FOR ANY FORM OF INDIRECT, SPECIAL, CONSEQUENTIAL OR PUNITIVE DAMAGES, ARISING OUT OF THE USE, SERVICE OR INSTALLATION, OF THE PRODUCTS, WHETHER SUCH DAMAGES ARISE IN CONTRACT OR TORT, IRRESPECTIVE OF FAULT, NEGLIGENCE OR STRICT LIABILITY OR WHETHER SCHNEIDER ELECTRIC HAS BEEN ADVISED IN ADVANCE OF THE POSSIBILITY OF SUCH DAMAGES, SPECIFICALLY, SCHNEIDER ELECTRIC IS NOT LIABLE FOR ANY COSTS, SUCH AS LOST PROFITS OR REVENUE, LOSS OF EQUIPMENT, LOSS OF USE OF EQUIPMENT, LOSS OF SOFTWARE, LOSS OF DATA, COSTS OF SUBSTITUANTS, CLAIMS BY THIRD PARTIES, OR OTHERWISE.

NO SALESMAN, EMPLOYEE OR AGENT OF SCHNEIDER ELECTRIC IS AUTHORIZED TO ADD TO OR VARY THE TERMS OF THIS WARRANTY. WARRANTY TERMS MAY BE MODIFIED, IF AT ALL, ONLY IN WRITING SIGNED BY AN SCHNEIDER ELECTRIC OFFICER AND LEGAL DEPARTMENT.

Warranty Claims

Customers with warranty claims issues may access the SCHNEIDER ELECTRIC worldwide customer support network through the SCHNEIDER ELECTRIC web site: <http://www.schneider-electric.com>. Select your country from the country selection pull-down menu. Open the Support tab at the top of the web page to obtain contact information for customer support in your region.

Schneider Electric
35 rue Joseph Monier
92500 Rueil Malmaison
France

+ 33 (0) 1 41 29 70 00



As standards, specifications, and design change from time to time,
please ask for confirmation of the information given in this publication.

© 2019 – 2023 Schneider Electric. All rights reserved.

990-91318D-001