



Cisco Catalyst 9400 Series Switches Hardware Installation Guide

First Published: 2017-09-20

Last Modified: 2023-11-07

Americas Headquarters

Cisco Systems, Inc.
170 West Tasman Drive
San Jose, CA 95134-1706
USA
<http://www.cisco.com>
Tel: 408 526-4000
800 553-NETS (6387)
Fax: 408 527-0883



CONTENTS

CHAPTER 1

Safety Warnings 1

Network Equipment-Building System (NEBS) Statements 2

CHAPTER 2

Product Overview 5

Switch Models 5

Catalyst 9404R Switch 5

Catalyst 9407R Switch 9

Catalyst 9410R Switch 13

Fan Tray Assembly 17

Fan Tray Assembly Overview 17

Operation 19

High Availability 19

Thresholds, Alarms, and Abnormal Acoustic Conditions 19

Power Supply Module 20

Power Supply Module Overview 20

Power Supply Modes 24

Power Supply Module Installation Considerations 25

CHAPTER 3

Preparing for Installation 27

Site Requirements 27

Temperature 28

Air Flow 28

Humidity 30

Altitude 30

Dust and Particles 30

Air Quality	31
Corrosion	31
EMI and Radio Frequency Interference	32
Shock and Vibration	33
Power Source Interruptions	33
System Grounding	34
Maintaining Safety with Electricity	36
Preventing ESD Damage	37
Power Requirements	38
Power Connection Guidelines for AC-Powered Systems	38
Power Connection Guidelines for DC-Powered Systems	39
Cabling Requirements	43
Rack-Mounting Guidelines	43
Site Preparation Checklist	45

CHAPTER 4 **Standard Accessory Kit Contents** 47

CHAPTER 5	Installing the Switch	49
	Installation Tasks	49
	Unpacking the Switch	53
	Install the Switch as Shipped	53
	Rack-Mounting the Chassis as Shipped	53
	Install the Switch with Shelf Brackets	56
	Shelf Kit Contents	56
	Installing the Shelf Kit L Brackets	57
	Installing the Shelf Brackets	61
	Rack-Mounting the Chassis	63
	Installing the Cable Guide	69
	Installing the Cable Guide With Shelf Brackets	69
	Installing the Cable Guide Without Shelf Brackets	72
	Install the Switch in a NEBS-Compliant Mode	74
	NEBS-Compliant Air Filter	74
	Rack-Mounting the Chassis in a NEBS-Compliant Mode	75
	Establishing System Ground	83

Attaching an ESD Strap	85
Verifying the Switch Chassis Installation	88

CHAPTER 6**Removing and Replacing FRUs 89**

Removing and Installing a Fan Tray	89
Enabling the Service Mode Before Removing a Fan Tray	90
Removing a Fan Tray from the Front	90
Installing a Fan Tray from the Front	93
Removing a Fan Tray from the Rear	94
Installing a Fan Tray from the Rear	97
Verifying Fan Tray Installation	98
Removing and Installing a Power Supply Module	99
Removing and Installing an AC-Input Power Supply Module	100
Removing an AC-Input Power Supply Module	100
Installing an AC-Input Power Supply Module	104
Power Cord Retainer Mechanism	107
Removing and Installing a DC-Input Power Supply Module	112
Required Tools and Equipment	112
Removing a DC-Input Power Supply Module	113
Installing a DC-Input Power Supply Module	119
Removing and Installing a Power Supply Blank	127
Verifying the Power Supply Module Installation	129

CHAPTER 7**Troubleshooting 131**

About this Section	131
System Boot Verification	131
Using LEDs to Identify Startup Problems	132
System Messages	133
Troubleshooting with Software	133
Troubleshooting a Power Supply Module	134
Useful Cisco IOS Commands - Power Supply	134
Troubleshooting an AC-Input Power Supply	134
Troubleshooting a DC-Input Power Supply	135
Restoring the Default Mode of the Power Button for a DC Power Supply Module	136

Troubleshooting the Fan Tray Assembly	137
Useful Cisco IOS Commands - Fan Tray Assembly	139
Troubleshooting High Temperature Alarms	139
Troubleshooting the Line Card	140
Useful Cisco IOS Commands - Line Cards	140
Troubleshooting Supervisor Modules	140
Supervisor Module LEDs	140
Standby Supervisor Engine Problems	140
Switch Self Reset	141
Cannot Connect to a Switch Through the Console Port	141
Boot Problems	144
Finding the Serial Number	144
Contacting the Cisco Technical Assistance Center	146

CHAPTER 8
Specifications 147

Chassis Specifications	147
Catalyst 9404R Switch Chassis Specifications	147
Catalyst 9407R Switch Chassis Specifications	149
Catalyst 9410R Switch Chassis Specifications	151
Power Supply Specifications	153
2100-W AC-Input Power Supply Specifications	153
2100-W Power Supply Module AC Power Cords	154
3200-W AC-Input Power Supply Specifications	157
3200-W Power Supply Module AC Power Cords	158
3200-W DC-Input Power Supply Specifications	161
Chassis and Module Power and Heat Values	162
Weight Specifications	163

CHAPTER 9
LEDs 167

Fan Tray LEDs	167
Power Supply LEDs	168
Cisco Catalyst 9400 Series Line Card LEDs	169
Cisco Catalyst 9400 Series Supervisor Module LEDs	170

CHAPTER 10	Initial Configuration for the Switch	175
	Options for Initial Configuration	175
	Configuring the Switch Using the Web User Interface	175
	Configuring the Switch Using the CLI	176
	Starting the Terminal-Emulation Software	176
	Connecting to a Power Source	176
	Connecting the RJ-45 Console Port	177
	Connecting the USB Console Port	177
	IP Settings	178
	Performing the Initial Configuration	178
	Configuring the Switch in the ROMMON Mode	181
	Installing and Uninstalling the USB Driver	181
	Installing the Microsoft Windows USB Device Driver	181
	Installing the Cisco Microsoft Windows USB Driver	182
	Uninstalling the Cisco Microsoft Windows USB Driver	182
	Uninstalling the Cisco Microsoft Windows USB Driver	182

CHAPTER 11	Related Documentation	183
-------------------	------------------------------	------------

APPENDIX A	Analysis of Cabling Requirements for IEEE 802.3bt Type 4 Devices	185
-------------------	---	------------



CHAPTER 1

Safety Warnings

Safety warnings appear throughout this publication in procedures that may harm you if you perform them incorrectly. A warning symbol precedes each warning statement. The warnings below are general warnings that are applicable to the entire publication.



Warning **Statement 1071**—Warning Definition**IMPORTANT SAFETY INSTRUCTIONS**

Before you work on any equipment, be aware of the hazards involved with electrical circuitry and be familiar with standard practices for preventing accidents. Read the installation instructions before using, installing, or connecting the system to the power source. Use the statement number at the beginning of each warning statement to locate its translation in the translated safety warnings for this device.

SAVE THESE INSTRUCTIONS

Note **Statement 407**—Japanese Safety Instruction

You are strongly advised to read the safety instruction before using the product.

<https://www.cisco.com/web/JP/techdoc/pldoc/pldoc.html>

When installing the product, use the provided or designated connection cables/power cables/AC adapters.

〈製品仕様における安全上の注意〉
www.cisco.com/web/JP/techdoc/index.html

接続ケーブル、電源コードセット、ACアダプタ、バッテリーなどの部品は、必ず添付品または指定品をご使用ください。添付品・指定品以外をご使用になると故障や動作不良、火災の原因となります。また、電源コードセットは弊社が指定する製品以外の電気機器には使用できないためご注意ください。



Warning **Statement 1008**—Class 1 Laser Product

This product is a Class 1 laser product.

**Warning Statement 1017**—Restricted Area

This unit is intended for installation in restricted access areas. Only skilled, instructed, or qualified personnel can access a restricted access area.

**Warning Statement 1051**—Laser Radiation

Invisible laser radiation may be emitted from disconnected fibers or connectors. Do not stare into beams or view directly with optical instruments.

**Warning Statement 1055**—Class 1/1M Laser

Invisible laser radiation is present. Do not expose to users of telescopic optics. This applies to Class 1/1M laser products.

**Warning Statement 1056**—Unterminated Fiber Cable

Invisible laser radiation may be emitted from the end of the unterminated fiber cable or connector. Do not view directly with optical instruments. Viewing the laser output with certain optical instruments, for example, eye loupes, magnifiers, and microscopes, within a distance of 100 mm, may pose an eye hazard.

**Warning Statement 1074**—Comply with Local and National Electrical Codes

To reduce risk of electric shock or fire, installation of the equipment must comply with local and national electrical codes.

**Warning Statement 9001**—Product Disposal

Ultimate disposal of this product should be handled according to all national laws and regulations.

- [Network Equipment-Building System \(NEBS\) Statements, on page 2](#)

Network Equipment-Building System (NEBS) Statements

NEBS describes the environment of a typical United States Regional Bell Operating Company (RBOC) central office. NEBS is the most common set of safety, spatial, and environmental design standards applied to

telecommunications equipment in the United States. It is not a legal or regulatory requirement, but rather an industry requirement.

The following NEBS statements apply to the Cisco Catalyst 9400 Series Switches:



Warning **Statement 7003**—Shielded Cable Shielded Cable Requirements for Intrabuilding Lightning Surge

The intrabuilding port(s) of the equipment or subassembly must use shielded intrabuilding cabling/wiring that is grounded at both ends.

The following port(s) are considered intrabuilding ports on this equipment:

RJ45 copper Ethernet Ports



Note **Statement 7004**—Special Accessories Required to Comply with GR-1089 Emission and Immunity Requirements

To comply with the emission and immunity requirements of GR-1089, shielded cables are required for the following ports:

Ethernet Ports



Warning **Statement 7005**—Intrabuilding Lightning Surge and AC Power Fault

The intrabuilding port(s) of the equipment or subassembly must not be metallically connected to interfaces that connect to the outside plant (OSP) or its wiring. These interfaces are designed for use as intrabuilding interfaces only (Type 2 or Type 4 ports as described in GR-1089-CORE) and require isolation from the exposed OSP cabling. The addition of primary protectors is not sufficient protection to connect these interfaces metallically to OSP wiring.

This statement applies to the intrabuilding ports listed below:

RJ45 copper Ethernet Ports



CHAPTER 2

Product Overview

- [Switch Models, on page 5](#)
- [Fan Tray Assembly, on page 17](#)
- [Power Supply Module, on page 20](#)

Switch Models

The following sections provide detailed information about the available switch models:

Catalyst 9404R Switch

The Catalyst 9404R Switch is a four-slot modular chassis, with two redundant supervisor module slots, two line card slots with up to 96 front panel ports, one nonredundant fan tray assembly, and has a provision to accommodate up to four power supply modules.

Front View of the Catalyst 9404R Switch

The figure shows a front view of the chassis, with the major components identified:

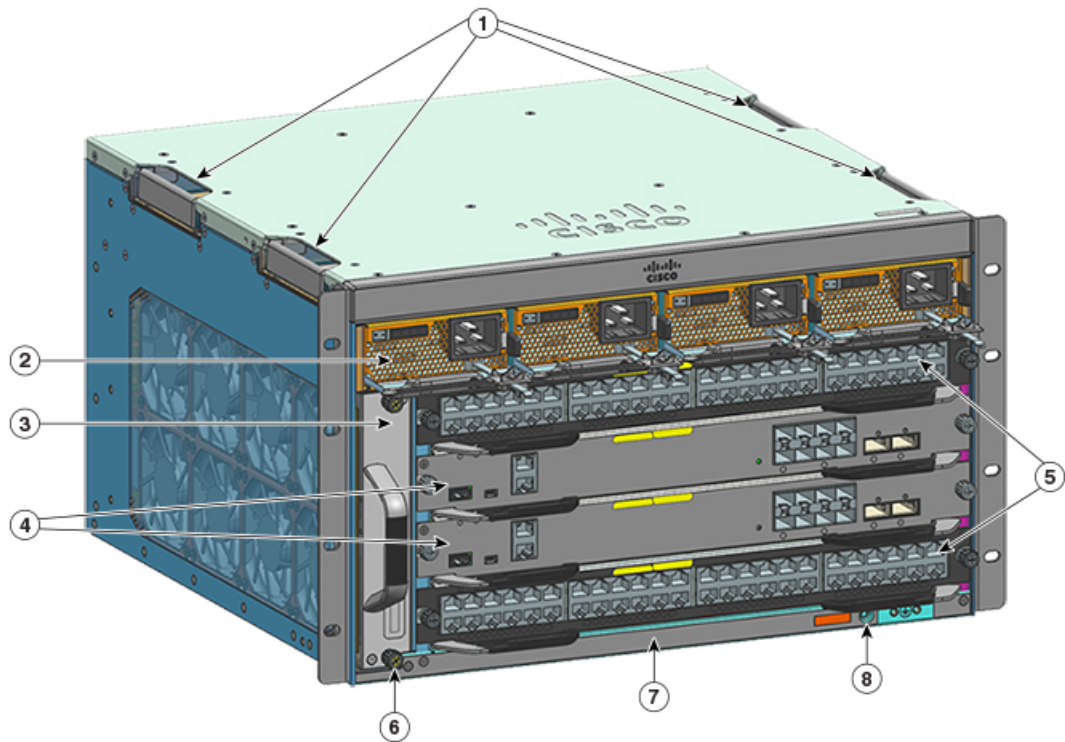

355574

1	Chassis handholds	5	Line card slots (1 and 4)
2	Power supply modules	6	Chassis Radio Frequency ID (RFID)
3	Fan tray assembly	7	Chassis model number
4	Supervisor module slots (2 and 3)	8	System ground

Rear View of the Catalyst 9404R Switch

The figure shows a rear view of the chassis, with the major components identified:

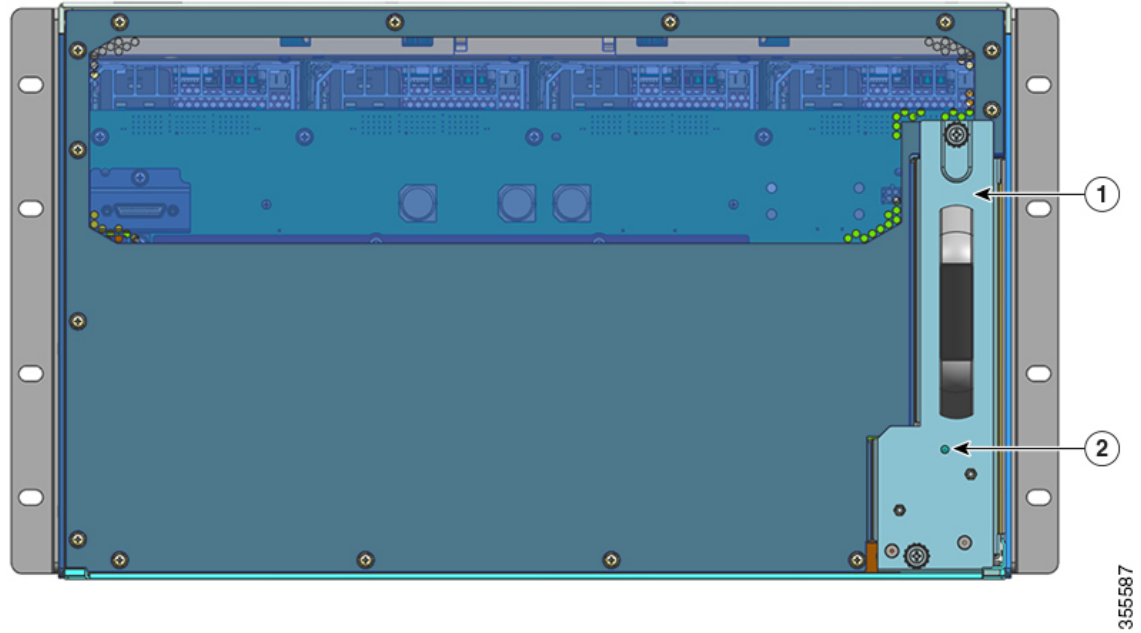

355587

1	Access to remove fan tray from the rear	2	Blue beacon LED on the rear panel of the fan tray (always matches the blue beacon on the front panel of the fan tray)
---	---	---	---

Table 1: Catalyst 9404R Switch Features

Feature	Description
Product ID	Chassis model number (add = for spare)—Cisco Catalyst 9400 Series 4 Slot Chassis(C9404R)
Chassis	Has four horizontal slots. Slots are numbered 1 (left) to 4 (right).

Feature	Description
Supervisor modules	<p>Supports 1+1 supervisor module redundancy for integrated resiliency. Supported model numbers (add = for spare):</p> <ul style="list-style-type: none"> • Cisco Catalyst 9400 Series Supervisor 1 Module (C9400-SUP-1) • Cisco Catalyst 9400 Series Supervisor 1XL Module (C9400-SUP-1XL) • Cisco Catalyst 9400 Series Supervisor 1XL-Y 25G Module (C9400-SUP-1XL-Y) • Cisco Catalyst 9400 Series Supervisor 2 Module (C9400X-SUP-2) • Cisco Catalyst 9400 Series Supervisor 2XL Module (C9400X-SUP-2XL) <p>Supervisor modules:</p> <ul style="list-style-type: none"> • Must be installed in slots numbered 2 and 3 only. • Have minimum software release version requirements. Refer to your software release notes for this information. <p>See Cisco Catalyst 9400 Series Supervisor Module Installation Note.</p>
Line cards	<p>Accommodates two line cards. Supported model numbers (add = for spare):</p> <ul style="list-style-type: none"> • Cisco Catalyst 9400 Series 12-Port 40G/100G Module (C9400-LC-12QC) • Cisco Catalyst 9400 Series 24-Port SFP Module (C9400-LC-24S) • Cisco Catalyst 9400 Series 24-Port SFP/SFP+ Module (C9400-LC-24XS) • Cisco Catalyst 9400 Series 24-Port 10G/25G Module (C9400-LC-24XY) • Cisco Catalyst 9400 Series 48-Port Gigabit Ethernet UPOE+ 10/100/1000 Module (C9400-LC-48H) • Cisco Catalyst 9400 Series 48-Port UPOE+ 100 Mbps/1G/2.5G/5G Multigigabit Module (C9400-LC-48HN) • Cisco Catalyst 9400 Series 48-Port UPOE+ 100 Mbps/1G/2.5G/5G/10G Multigigabit Module (C9400-LC-48HX) • Cisco Catalyst 9400 Series 48-Port Gigabit Ethernet POE/POE+ Module (C9400-LC-48P) • Cisco Catalyst 9400 Series 48-Port SFP Module (C9400-LC-48S) • Cisco Catalyst 9400 Series 48-Port 10/100/1000 Module (C9400-LC-48T) • Cisco Catalyst 9400 Series 48-Port UPOE 10/100/1000 Module (C9400-LC-48U) • Cisco Catalyst 9400 Series 48-Port UPOE Multigigabit Module (C9400-LC-48UX) • Cisco Catalyst 9400 Series 48-Port SFP/SFP+ Module (C9400-LC-48XS) <p>See Cisco Catalyst 9400 Series Line Card Installation Note.</p>

Feature	Description
Fan tray assembly	The switch supports a single front and rear serviceable and hot-swappable fan tray with 8 fans. Supported model number (add = for spare)—C9404-FAN See Fan Tray Assembly Overview, on page 17 and Fan Tray LEDs, on page 167 .
Power supplies	The chassis supports up to four field-replaceable AC-input and DC-input power supply modules. Supported model numbers (add = for spare): <ul style="list-style-type: none"> • C9400-PWR-2100AC • C9400-PWR-3200AC • C9400-PWR-3200DC See Power Supply Module Overview, on page 20 and Power Supply LEDs, on page 168 .
Backplane	With C9400-SUP-1, the backplane bandwidth is 80 Gbps. With C9400-SUP-1XL, C9400-SUP-1XL-Y, and C9400X-SUP-2, the backplane bandwidth is 240 Gbps for each payload module slot. With C9400X-SUP-2XL, the backplane bandwidth is 480 Gbps for each payload module slot.
RFID Tag	Has a built-in, front-facing, non-removable, passive RFID tag that uses Ultra High Frequency (UHF) RFID technology and requires an RFID reader with compatible software. For more information, see Radio Frequency Identification (RFID) on Cisco Catalyst 9000 Family Switches .

Catalyst 9407R Switch

The Catalyst 9407R Switch is a seven-slot modular chassis, with two redundant supervisor module slots, five line card slots with up to 240 front panel ports, one non-redundant fan tray assembly, and a provision to accommodate up to eight power supply modules.

Front View of the Catalyst 9407R Switch

The figure shows a front view of the chassis, with the major components identified:

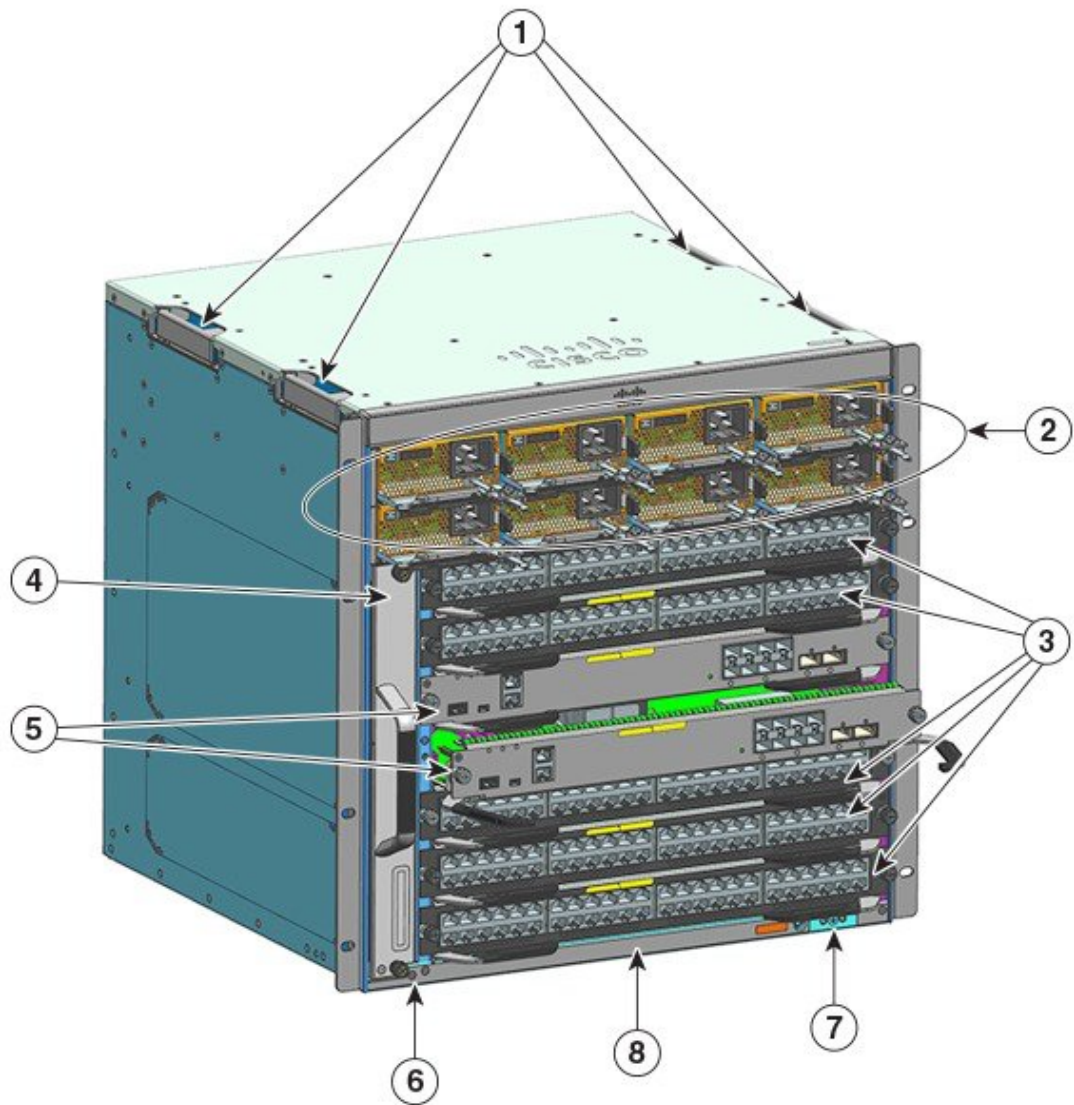

355105

1	Chassis handholds	5	Supervisor module slots (3 and 4)
2	Power supply modules	6	Chassis Radio Frequency ID (RFID)
3	Line card slots (1,2, 5,6, and 7)	7	System ground
4	Fan tray assembly	8	Chassis model number

Rear View of the Catalyst 9407R Switch

The figure shows a rear view of the chassis, with the major components identified:

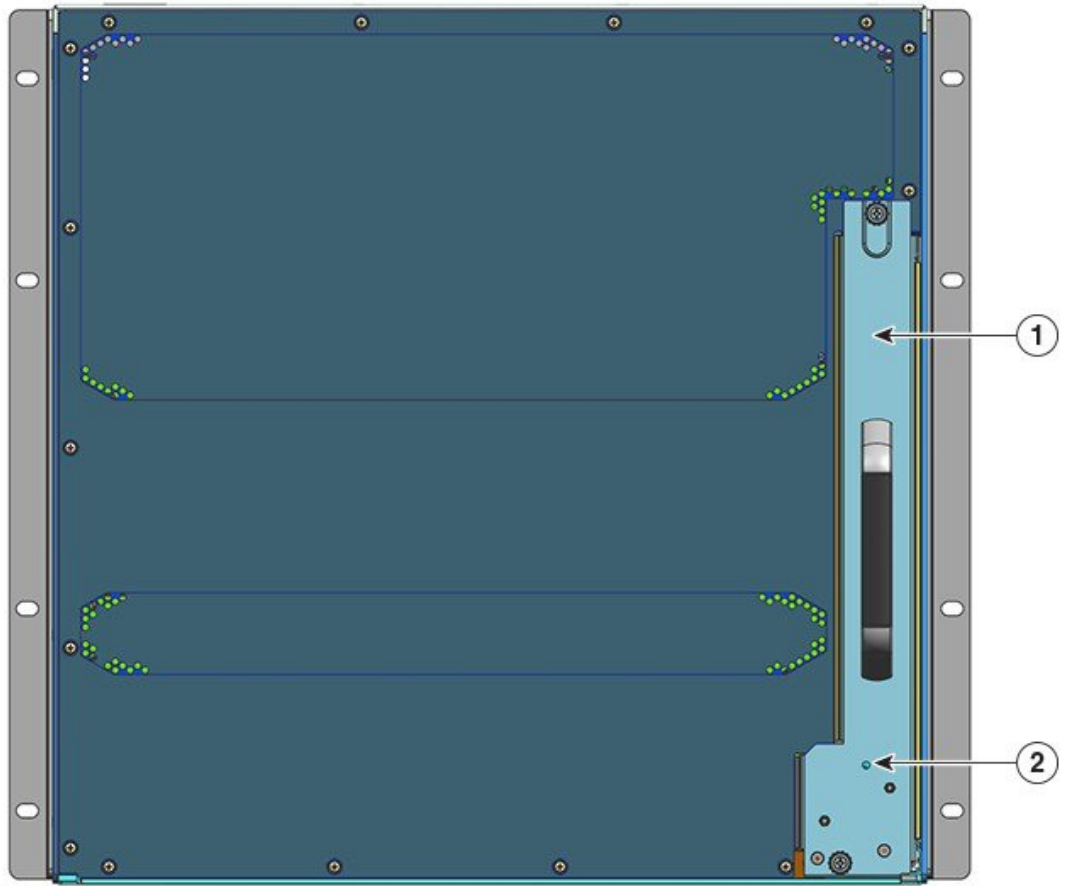

355140

1	Access to remove fan tray from the rear	2	Blue beacon LED on the rear panel of the fan tray (always matches the blue beacon on the front panel of the fan tray)
---	---	---	---

Table 2: Catalyst 9407R Switch Features

Feature	Description
Product ID	Chassis model number (add = for spare)—Cisco Catalyst 9400 Series 7 Slot Chassis(C9407R)
Chassis	Has seven horizontal slots. Slots are numbered 1 (top) to 7 (bottom).

Feature	Description
Supervisor modules	<p>Supports 1+1 supervisor module redundancy for integrated resiliency. Supported model numbers (add = for spare):</p> <ul style="list-style-type: none"> • Cisco Catalyst 9400 Series Supervisor 1 Module (C9400-SUP-1) • Cisco Catalyst 9400 Series Supervisor 1XL Module (C9400-SUP-1XL) • Cisco Catalyst 9400 Series Supervisor 1XL-Y 25G Module (C9400-SUP-1XL-Y) • Cisco Catalyst 9400 Series Supervisor 2 Module (C9400X-SUP-2) • Cisco Catalyst 9400 Series Supervisor 2XL Module (C9400X-SUP-2XL) <p>Supervisor modules:</p> <ul style="list-style-type: none"> • Must be installed in slots numbered 3 and 4 only. • Have minimum software release version requirements. Refer to your software release notes for this information. <p>See Cisco Catalyst 9400 Series Supervisor Module Installation Note.</p>
Line Cards	<p>Accommodates five line cards. Supported model numbers (add = for spare):</p> <ul style="list-style-type: none"> • Cisco Catalyst 9400 Series 12-Port 40G/100G Module (C9400-LC-12QC) • Cisco Catalyst 9400 Series 24-Port SFP Module (C9400-LC-24S) • Cisco Catalyst 9400 Series 24-Port SFP/SFP+ Module (C9400-LC-24XS) • Cisco Catalyst 9400 Series 24-Port 10G/25G Module (C9400-LC-24XY) • Cisco Catalyst 9400 Series 48-Port Gigabit Ethernet UPOE+ 10/100/1000 Module (C9400-LC-48H) • Cisco Catalyst 9400 Series 48-Port UPOE+ 100 Mbps/1G/2.5G/5G Multigigabit Module (C9400-LC-48HN) • Cisco Catalyst 9400 Series 48-Port UPOE+ 100 Mbps/1G/2.5G/5G/10G Multigigabit Module (C9400-LC-48HX) • Cisco Catalyst 9400 Series 48-Port Gigabit Ethernet POE/POE+ Module (C9400-LC-48P) • Cisco Catalyst 9400 Series 48-Port SFP Module (C9400-LC-48S) • Cisco Catalyst 9400 Series 48-Port 10/100/1000 Module (C9400-LC-48T) • Cisco Catalyst 9400 Series 48-Port UPOE 10/100/1000 Module (C9400-LC-48U) • Cisco Catalyst 9400 Series 48-Port UPOE Multigigabit Module (C9400-LC-48UX) • Cisco Catalyst 9400 Series 48-Port SFP/SFP+ Module (C9400-LC-48XS) <p>See Cisco Catalyst 9400 Series Line Card Installation Note.</p>

Feature	Description
Fan tray assembly	The switch supports a single front and rear serviceable and hot-swappable fan tray with 12 fans. Supported model number (add = for spare)—C9407-FAN See Fan Tray Assembly Overview, on page 17 and Fan Tray LEDs, on page 167 .
Power supplies	The chassis supports up to eight field-replaceable AC-input and DC-input power supply modules. Supported model numbers (add = for spare): <ul style="list-style-type: none"> • C9400-PWR-2100AC • C9400-PWR-3200AC • C9400-PWR-3200DC See Power Supply Module Overview, on page 20 and Power Supply LEDs, on page 168 .
Backplane	With C9400-SUP-1, the backplane bandwidth is 80Gbps. With C9400-SUP-1XL and C9400-SUP-1XL-Y, the backplane bandwidth is 120 Gbps for each payload module slot. With C9400X-SUP-2, the backplane bandwidth is 240 Gbps for each payload module slot. With C9400X-SUP-2XL, the backplane bandwidth is 480 Gbps for each payload module slot.
RFID Tag	Has a built-in, front-facing, non-removable, passive RFID tag that uses Ultra High Frequency (UHF) RFID technology and requires an RFID reader with compatible software. For more information, see Radio Frequency Identification (RFID) on Cisco Catalyst 9000 Family Switches .

Catalyst 9410R Switch

The Catalyst 9410R Switch is a ten-slot modular chassis, with two redundant supervisor module slots, eight line card slots with up to 384 1-Gigabit Ethernet front panel ports, one non-redundant fan tray assembly, and a provision to accommodate up to eight power supply modules.

Front View of the Catalyst 9410R Switch

The figure shows a front view of the chassis, with the major components identified:

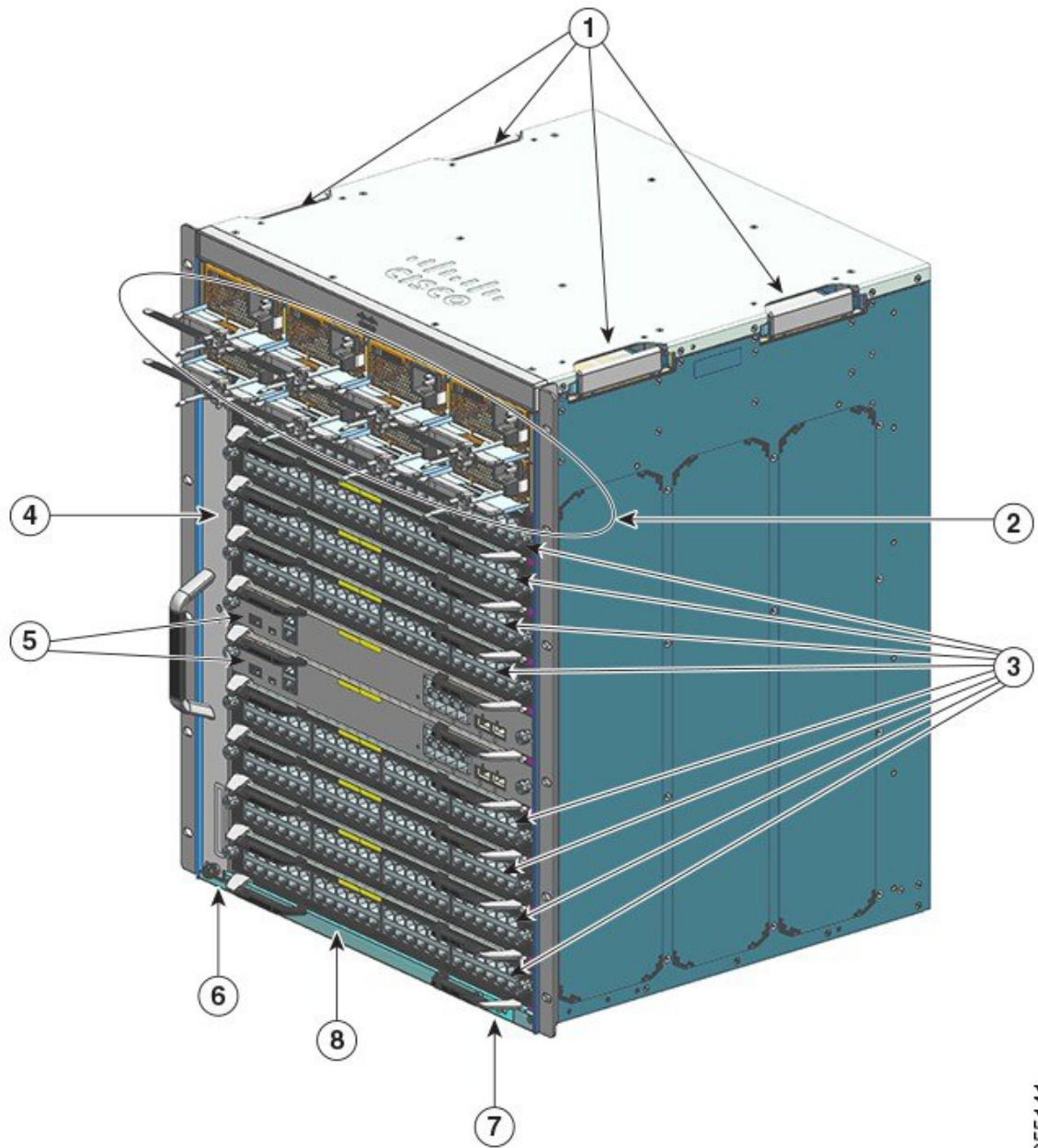

355141

1	Chassis handholds	5	Supervisor module slots (5 and 6)
2	Power supply modules	6	Chassis Radio Frequency ID (RFID)
3	Line card slots (1,2, 3, 4, 7, 8, 9 and 10)	7	System ground
4	Fan tray assembly	8	Chassis model number

Rear View of the Catalyst 9410R Switch

The figure shows a rear view of the chassis, with the major components identified:

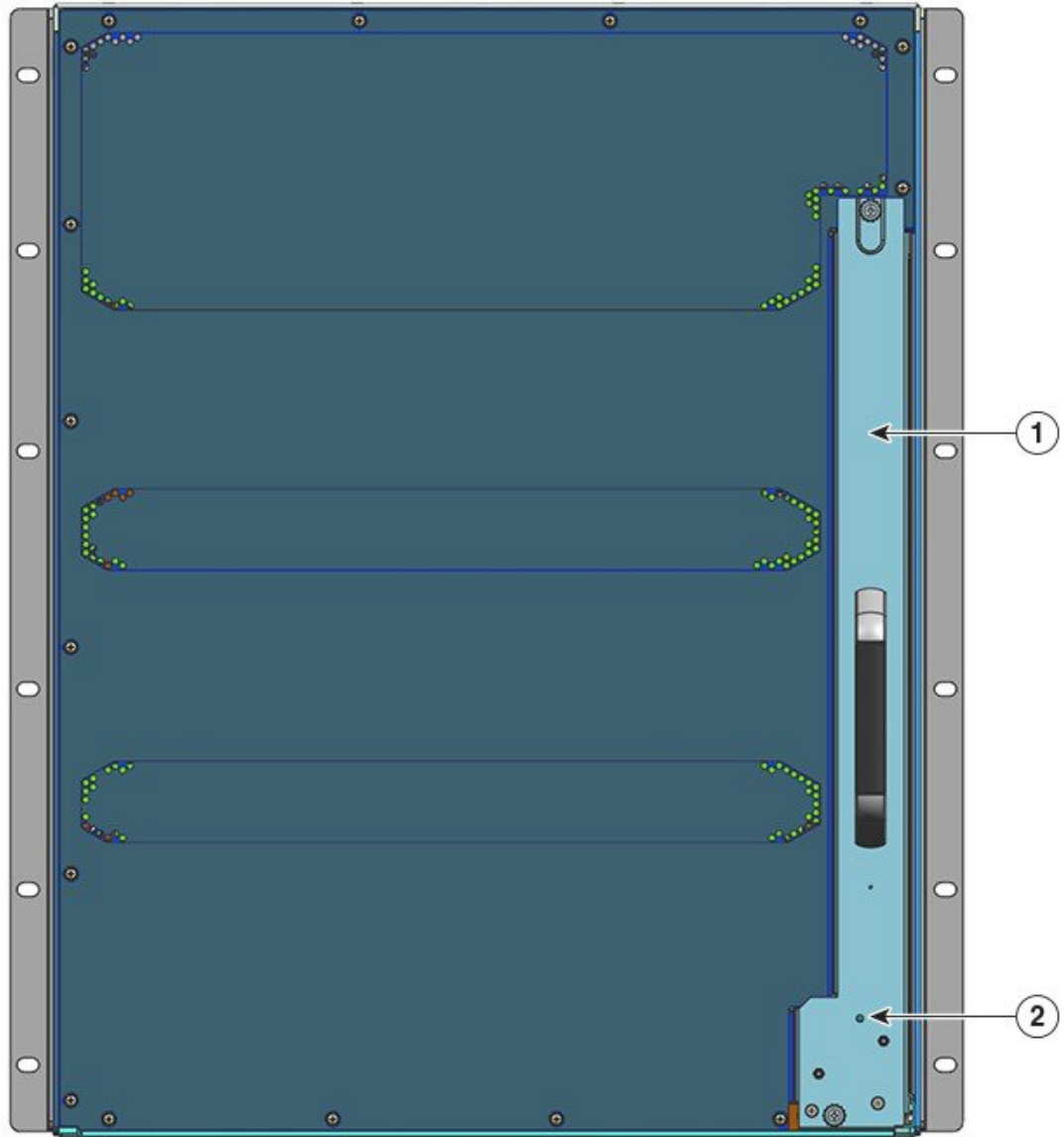

355142

1	Access to remove fan tray from the rear	2	Blue beacon LED on the rear of the fan tray (always matches the blue beacon on the front of the fan tray)
---	---	---	---

Table 3: Catalyst 9410R Switch Features

Feature	Description
Product ID	Chassis model number (add = for spare)—Cisco Catalyst 9400 Series 10 Slot Chassis(C9410R)
Chassis	Has ten horizontal slots. Slots are numbered 1 (top) to 10 (bottom).

Feature	Description
Supervisor modules	<p>Supports 1+1 supervisor module redundancy for integrated resiliency. Supported model numbers (add = for spare):</p> <ul style="list-style-type: none"> • Cisco Catalyst 9400 Series Supervisor 1 Module (C9400-SUP-1) • Cisco Catalyst 9400 Series Supervisor 1XL Module (C9400-SUP-1XL) • Cisco Catalyst 9400 Series Supervisor 1XL-Y 25G Module (C9400-SUP-1XL-Y) • Cisco Catalyst 9400 Series Supervisor 2 Module (C9400X-SUP-2) • Cisco Catalyst 9400 Series Supervisor 2XL Module (C9400X-SUP-2XL) <p>Supervisor modules:</p> <ul style="list-style-type: none"> • Must be installed in slots numbered 5 and 6 only. • Have minimum software release version requirements. Refer to your software release notes for this information. <p>See Cisco Catalyst 9400 Series Supervisor Module Installation Note.</p>
Line Cards	<p>Accommodates eight line cards. Supported model numbers (add = for spare):</p> <ul style="list-style-type: none"> • Cisco Catalyst 9400 Series 12-Port 40G/100G Module (C9400-LC-12QC) • Cisco Catalyst 9400 Series 24-Port SFP Module (C9400-LC-24S) • Cisco Catalyst 9400 Series 24-Port SFP/SFP+ Module (C9400-LC-24XS) • Cisco Catalyst 9400 Series 24-Port 10G/25G Module (C9400-LC-24XY) • Cisco Catalyst 9400 Series 48-Port Gigabit Ethernet UPOE+ 10/100/1000 Module (C9400-LC-48H) • Cisco Catalyst 9400 Series 48-Port UPOE+ 100 Mbps/1G/2.5G/5G Multigigabit Module (C9400-LC-48HN) • Cisco Catalyst 9400 Series 48-Port UPOE+ 100 Mbps/1G/2.5G/5G/10G Multigigabit Module (C9400-LC-48HX) • Cisco Catalyst 9400 Series 48-Port Gigabit Ethernet POE/POE+ Module (C9400-LC-48P) • Cisco Catalyst 9400 Series 48-Port SFP Module (C9400-LC-48S) • Cisco Catalyst 9400 Series 48-Port 10/100/1000 Module (C9400-LC-48T) • Cisco Catalyst 9400 Series 48-Port UPOE 10/100/1000 Module (C9400-LC-48U) • Cisco Catalyst 9400 Series 48-Port UPOE Multigigabit Module (C9400-LC-48UX) • Cisco Catalyst 9400 Series 48-Port SFP/SFP+ Module (C9400-LC-48XS) <p>See Cisco Catalyst 9400 Series Line Card Installation Note.</p>

Feature	Description
Fan tray assembly	The switch supports a single front and rear serviceable and hot-swappable fan tray with 16 fans. Supported model number (add = for spare)—C9410-FAN See Fan Tray Assembly Overview, on page 17 and Fan Tray LEDs, on page 167 .
Power supplies	The chassis supports up to eight field-replaceable AC-input and DC-input power supply modules. Supported model numbers (add = for spare): <ul style="list-style-type: none"> • C9400-PWR-2100AC • C9400-PWR-3200AC • C9400-PWR-3200DC See Power Supply Module Overview, on page 20 and Power Supply LEDs, on page 168 .
Backplane	With C9400-SUP-1, C9400-SUP-1XL, and C9400-SUP-1XL-Y, the backplane bandwidth is 80Gbps for each payload module slot. With C9400X-SUP-2 the backplane bandwidth is 240 Gbps for each payload module slot. With C9400X-SUP-2XL the backplane bandwidth is 480 Gbps for each payload module slot.
RFID Tag	Has a built-in, front-facing, non-removable, passive RFID tag that uses Ultra High Frequency (UHF) RFID technology and requires an RFID reader with compatible software. For more information, see Radio Frequency Identification (RFID) on Cisco Catalyst 9000 Family Switches .

Fan Tray Assembly

The following sections provide detailed information about the fan tray assembly:

Fan Tray Assembly Overview



Warning **Statement 1073**—No User-Serviceable Parts

There are no serviceable parts inside. To avoid risk of electric shock, do not open.

A Cisco Catalyst 9400 Series fan tray assembly—

- Is composed of a fan tray and an adapter that is attached to the fan tray. It is responsible for cooling the entire chassis and interfacing with environmental monitors to trigger alarms when conditions exceed thresholds.
- Has side-to-side airflow for balanced airflow across the inserted cards. When facing the front of the chassis, airflow direction is right to left.
- Can be installed and removed from the front and the rear.

- Has a built-in, front-facing, non-removable, passive RFID tag that uses Ultra High Frequency (UHF) RFID technology and requires an RFID reader with compatible software. For more information, see [Radio Frequency Identification \(RFID\) on Cisco Catalyst 9000 Family Switches](#).

Is chassis-specific. (Add = to the model number for spares)

- Model number C9404-FAN for the Catalyst 9404R Switch.

This model has eight individual fans (two rows of four each). It supports a minimum airflow of 640 cubic feet per minute (CFM) at 100 percent fan throttle.

- Model number C9407-FAN for the Catalyst 9407R Switch.

This model has 12 individual fans (three rows). It supports a minimum airflow of 960 cubic feet per minute (CFM) at 100 percent fan throttle.

- Model number C9410-FAN for the Catalyst 9410R Switch.

This model has 16 individual fans (four rows). It supports a minimum airflow of 1190 CFM at 100 percent fan throttle.

The following figure shows the C9407-FAN with the major components identified. The C9410-FAN has the same features, and in addition, a fourth row of fans. The C9404-FAN has the same features but has only two rows of fans.

Figure 1: Fan Tray Assembly

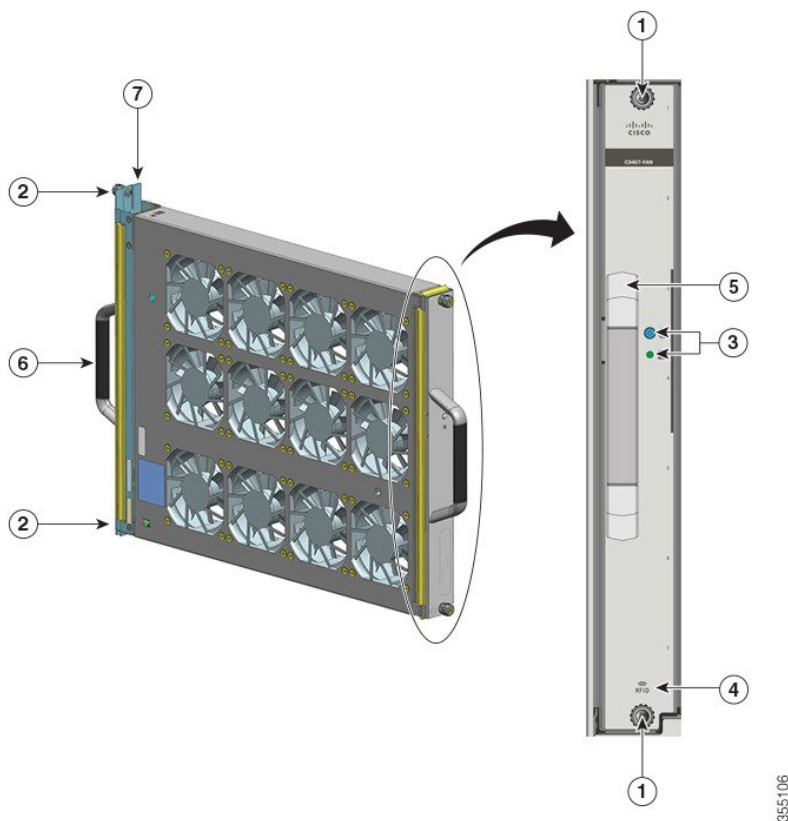

1	Captive installation screws on the front of the fan tray.	5	Front fan tray handle.
2	Captive installation screws on the rear of the fan tray.	6	Rear fan tray handle
3	LEDs on the front panel. (The rear blue beacon LED is not visible in this image)	7	Fan tray adapter
4	Fan tray RFID	-	-

Operation



Caution Do not operate the system if the fan tray assembly is removed or if it is not functioning properly. An overtemperature condition can cause severe equipment damage or an unscheduled system shutdown.

Depending on the ambient conditions, the system optimises the fan-speed for temperature and pressure and maintains the minimum fan speeds and temperatures that the chassis requires. Accordingly, the fan tray's internal controller operates in a normal mode and a Network Equipment-Building System mode (NEBS mode).

- In the normal mode—the controller optimizes fan-speed for temperature and pressure.
- In the NEBS mode—the controller responds more aggressively, to maintain proper cooling for installations with high airflow impedance. When the fan tray operates in this mode, there may be increased noise levels due to increased fan speeds.

You can also manually set the fan tray to operate in the NEBS mode.

High Availability

To ensure high availability, the system is designed to respond to fan failures by either minimising impact or by compensating and operating at a worst case scenario specification.

- If a single fan fails, the remaining fans in the row compensate with increased speed.
- If two or more fans fail, the entire fan tray operates at full speed after one minute. Further, the fan tray must be replaced. The individual fans are not field replaceable, you must replace the fan tray.
- If the temperature sensor fails or communication with the temperature sensor fails, the worst case operating temperature is assumed.
- If the pressure sensor fails or communication with the pressure sensor fails, the worst case operating pressure is assumed.

Thresholds, Alarms, and Abnormal Acoustic Conditions

Under normal operating conditions, when none of the temperature alarms have been triggered, hardware controls fan speed. If any of the system temperature alarms are triggered, software takes fan speed control

from hardware. Refer to the *System Management* section of the software configuration guide for more information.

When the fan tray operates at full speed, increased noise levels may be expected. The fan tray may operate at full speed in these circumstances:

- If the fan tray is not installed correctly
- When operating in the NEBS mode
- If two or more fans have failed
- If the STATUS LED remains red for more than one minute
- If there is a hardware failure
- If the software watchdog timer is triggered

Power Supply Module

The following sections provide detailed information about the available power supply modules:

Power Supply Module Overview

Available power supply module model numbers (Add = to the model number for spares):

- C9400-PWR-2100AC
- C9400-PWR-3200AC
- C9400-PWR-3200DC



Note Unless otherwise indicated, the power supply information provided in this document applies to all the available power supply modules.

The chassis supports field-replaceable AC-input and DC-input power supply modules. If you install modules of different types (AC input and DC input) and capacities, ensure that all the required conditions are met.

Features: AC-Input Power Supply

- Has a self-cooling mechanism, with a minimum airflow of 17 cubic feet per minute (CFM) at 100 percent load.
- Provides a regulated 55-VDC PoE-compliant main output and 3.3-VDC standby output.
- Supports only single-phase source AC. Source AC can be out of phase between multiple power supplies or multiple AC power plugs on the same power supply because all the AC power supply inputs are isolated.
- Has a release latch and cord-retention mechanism on the front panel of the module to avoid accidental removal of the module or the attached power cord.

- Supports redundant and combined configuration modes. A single (nonredundant) or a dual (redundant) power supply configuration can support the following loads:

Input Voltage (in Volts AC)	Output Power with C9400-PWR-3200AC (in Watts)	Output Power with C9400-PWR-2100AC (in Watts)
200-240 VAC	3200 W	2112 W
100-120 VAC	1570 W	950 W

- Has a built-in, front-facing, non-removable, passive RFID tag that uses Ultra High Frequency (UHF) RFID technology and requires an RFID reader with compatible software. For more information, see [Radio Frequency Identification \(RFID\) on Cisco Catalyst 9000 Family Switches](#).

Figure 2: C9400-PWR-3200AC

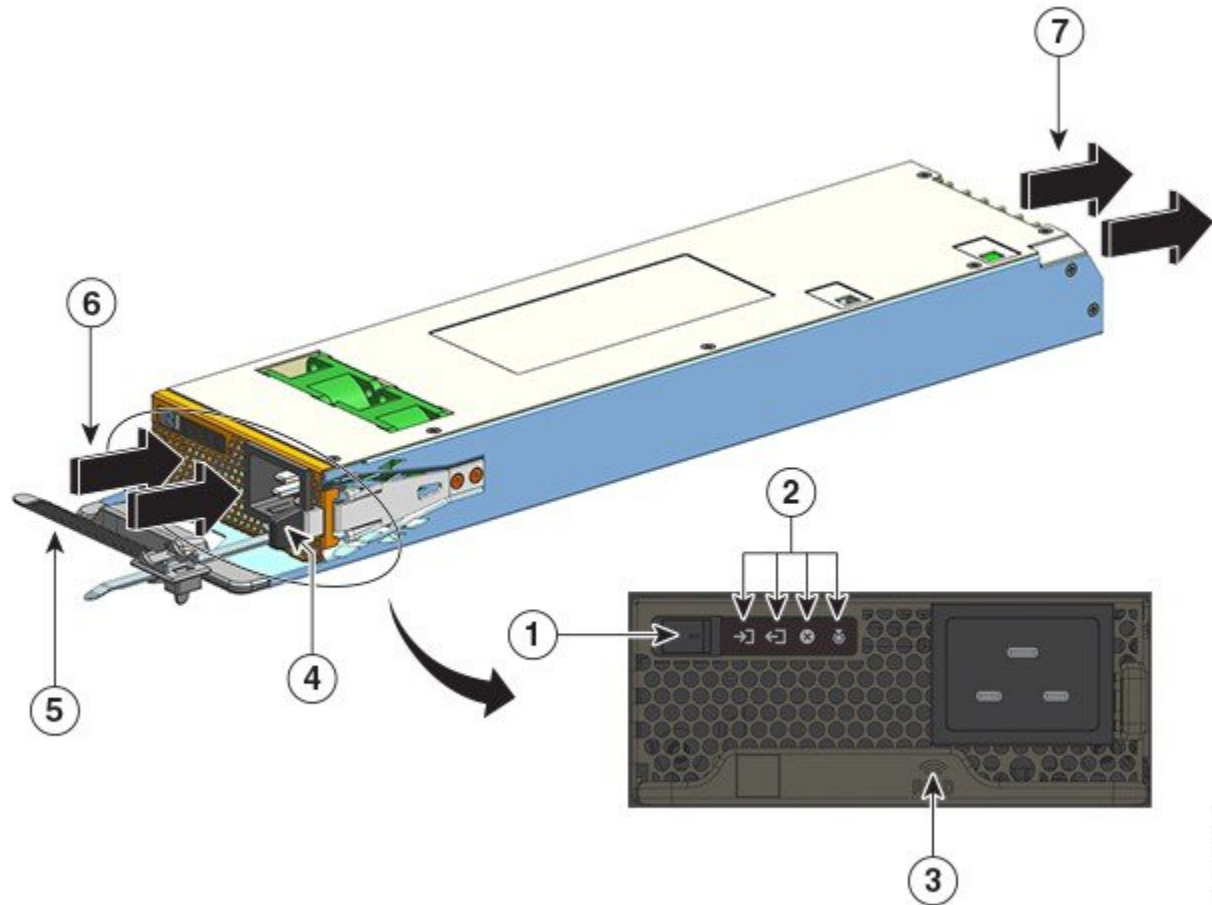

1	On/ Off rocker switch	5	Power cord retainer
2	LEDs.	6	Airflow intake
3	Power supply module RFID	7	Airflow exhaust

355178

4	Release latch	-	-
---	---------------	---	---

Features: DC-Input Power Supply

- Has a self-cooling mechanism, with a minimum airflow of 9.5 cubic feet per minute (CFM) at 100 percent load.
- Has a release latch mechanism on the side of the module to avoid accidental removal of the module.
- Has an On/ Off power button on the front panel. Press for two seconds to switch it on and off.

Pressing the power button on and off turns the main 55-VDC output on and off, respectively. Standby output power of 3.3-VDC is available whenever DC input is applied.

The power button has two modes of operation, which are described below. Press the power button for 10 seconds to toggle between modes; the LOCATE LED blinks for three seconds when you do.

- Auto-on: When in this mode, the power supply module automatically starts or restarts on application or restoration of DC input power. This is the default mode.

For NEBS compliance, the power button must be in the auto-on mode. When power is restored after a power failure, the power supply module recovers automatically.

- Protected: When in this mode, if the DC power source output voltage is zero, or drops out for more than three seconds, you must press the power button for two seconds, to restore operation.

- Has dual DC inputs.

Each input has an independent, isolated circuit. -A and +A form one DC-input; +B and -B form another. Each DC input can be powered either from separate sources, or a suitable single source. The module has one operational mode as a function of both inputs receiving power. When both the inputs are active, a regulated 55-VDC PoE-compliant main output and 3.3-VDC standby output is provided.

- Has DC-input reversal protection such that the unit will survive DC-input reversal up to the full input voltage rating.
- Supports redundant and combined configuration modes. A single (nonredundant) or a dual (redundant) power supply configuration, can support the following loads:

Input Voltage (in Volts DC)	Output Power with C9400-PWR-3200DC (in Watts)
40-72 VDC (with an extended range to 75 VDC) A voltage differential between inputs is acceptable, as long as the value is within the above range. For example, one DC input can have an input voltage of 40 VDC and the other, 75 VDC.	3200 W

- Has a built-in, front-facing, non-removable, passive RFID tag that uses Ultra High Frequency (UHF) RFID technology and requires an RFID reader with compatible software. For more information, see [Radio Frequency Identification \(RFID\) on Cisco Catalyst 9000 Family Switches](#).

Figure 3: C9400-PWR-3200DC

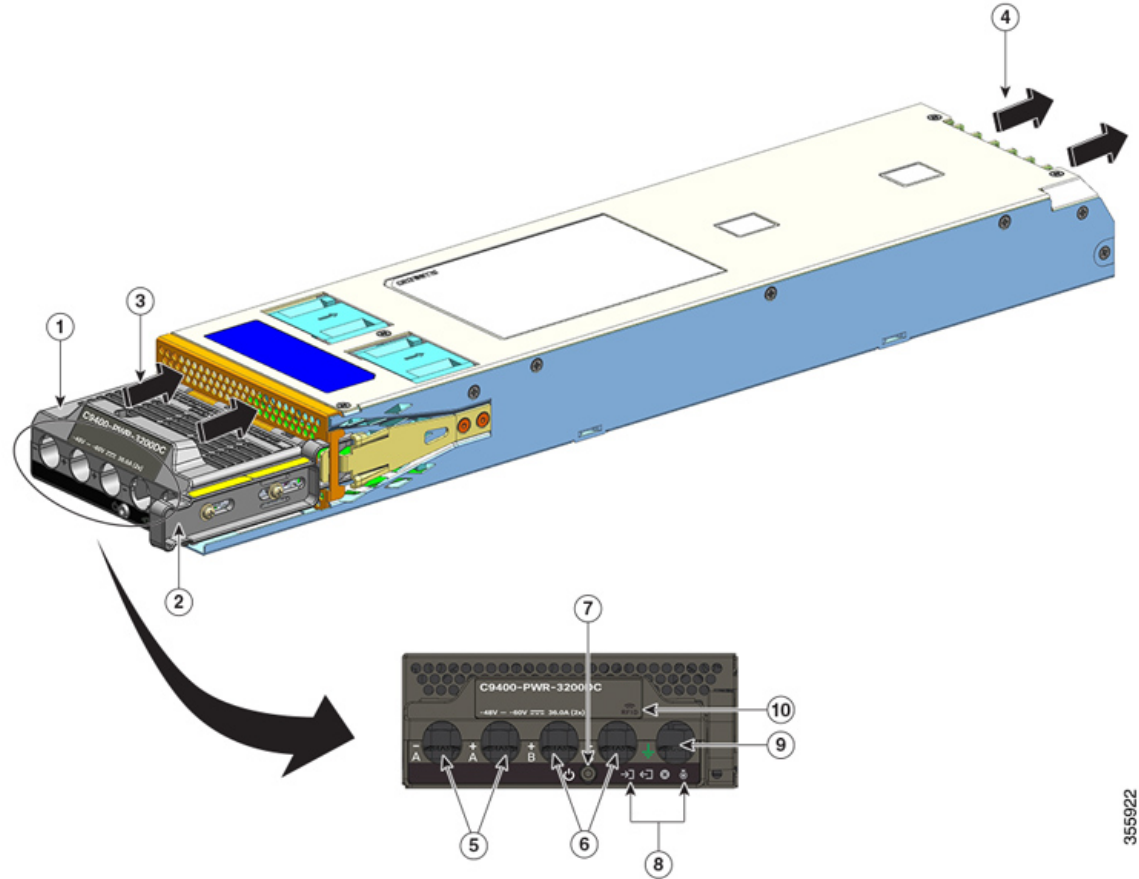

355922

1	Terminal block	6	Slots for DC input (+B and -B)
2	Release latch	7	On/ Off power button
3	Airflow intake	8	LEDs
4	Airflow exhaust	9	Slot for ground cable
5	Slots for DC input (-A and +A)	10	Power supply module RFID

Operation

The power supply connectors distribute power as follows:

Module	C9400-PWR-2100AC, C9400-PWR-3200AC, and C9400-PWR-3200DC
Supervisor Module (Main Output)	Maximum of 20 A at 55 VDC
Line Card (Main Output)	Maximum of 120 A at 55 VDC

Module	C9400-PWR-2100AC, C9400-PWR-3200AC, and C9400-PWR-3200DC
Fan Tray, Supervisor Module, Backplane (Standby Output)	3.3 VDC

Power Supply Modes

Cisco Catalyst 9400 Series Switches offer redundant and combined configuration modes for power supplies.

The number of power supply modules installed and the system load determine the power level that the system expects to draw from each power supply module, and consequently, the power supply mode that will be suitable. To calculate, or estimate a system's power budget, and to determine power supply requirements for a specific PoE configuration, use the [Cisco Power Calculator](#).

To configure a power supply mode, enter the **power redundancy-mode** command in global configuration mode. If you do not configure a mode, the default mode is applicable.

Combined Mode

This is the default power supply mode.

The system operates on one to eight power supply modules. The power available to the system is the sum of power outputs of all the power supply modules in the chassis. All available power supply modules are active, share power, and can operate at up to 100 percent capacity.



Caution When operating in combined mode, if any of the modules fail, all remaining operational power supply modules increase their output. If the output power does not meet the system requirements and the **power supply autole shutdown** command is *disabled*, all the operational power supply modules may get overloaded and go into overcurrent shutdown. All system power is then lost.

Redundant Mode

In a redundant configuration, a given power supply module can either be active, or in standby:

- An active power supply module is powered on, and provides output power. All the active modules in a chassis always attempt to share the load.
- A standby power supply module is powered on, but asleep, and can switch to active when required. When in standby mode, the power supply module's OUTPUT LED is blinking green.

To ensure high availability, the system is designed to respond to failure as follows:

- If all the available power supply modules are active, the operational power supplies continue to share current equally. Note that the load on the available power supplies would have increased.
- If standby power supply modules are available, the minimum number of power supply modules needed to power the load switch to active.

When configuring a redundant mode, you have these options: an n+1 or an n+n redundant mode.

N+1 Redundant Mode

N is the number of active power supply modules and can be one to seven power supply modules on a seven-slot or a ten-slot chassis, and one to three power supply modules on a four-slot chassis. $+1$ is the power supply module reserved for redundancy, and must be configured as the standby module (use the **power redundancy-mode** command in global configuration mode).

The default standby power supply slot on a seven-slot or a ten-slot chassis is eight. The default standby power supply slot on a four-slot chassis is four. To designate a different slot as standby, use the **power redundancy-mode** command in global configuration mode.

N+N Redundant Mode

N number of power supply modules are configured as active, and n number of power supply modules are configured as standby. To configure standby power supply modules, use the **power redundancy-mode** command in global configuration mode.

For detailed software configuration information including examples, see the required version of the [software configuration guide](#). In the guide, go to *Contents* → *System Management* → *Environmental Monitoring and Power Management*.

Power Supply Module Installation Considerations



Warning Statement 1028—More Than One Power Supply

This unit might have more than one power supply connection. To reduce risk of electric shock, remove all connections to de-energize the unit.

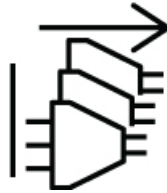

Warning Statement 1073—No User-Serviceable Parts

There are no serviceable parts inside. To avoid risk of electric shock, do not open.



Note While the installation of power supplies of different capacities in the same chassis is supported, it is not an optimal use of total system power in a redundant mode.

When installing power supply modules, ensure that the following conditions are met:

AC input Only

If you plan to install only AC-input power supply modules, you must meet these conditions in the context of the $N+1$ redundant mode, or $N+N$ redundant mode, or combined mode:

- All the installed power supply modules must be of the same capacity.

For example, all the installed modules are C9400-PWR-2100AC.

- All the installed power supply modules must have the same AC-input voltage level.

For example, all the power supply modules have an AC-input voltage of 220 VAC, or an AC-input voltage 110 VAC.

AC Input and DC Input with N+1 Redundant Mode or Combined Mode

If you plan to install a mix of AC-input and DC-input power supply modules, you must meet these conditions in the context of the N+1 redundant mode or combined mode:

- All the installed power supply modules must be of the same capacity.

For example, a mix of C9400-PWR-3200AC and C9400-PWR-3200DC are installed.

- All the installed AC-input power supply modules must have an AC-input voltage of 220 VAC.

AC Input and DC Input with N+N Redundant Mode

If you plan to install a mix of AC-input and DC-input power supply modules, you must meet these conditions in the context of the N+N redundant mode:

- All the power supply modules that are configured as active must be of the same type; all the modules that are configured as standby must be of the same type. (The type refers to AC input and DC input).

For example, all the installed active power supply modules are C9400-PWR-2100AC, all the installed standby power modules are C9400-PWR-3200DC.

- All the installed AC-input power supply modules in the chassis must be of the same capacity and have the same input voltage level.

Continuing with the above example, all the active power supply modules are C9400-PWR-2100AC, and have an input voltage of 115 VAC.

- All the installed DC-input power supply modules must be configured as standby.

Continuing with the above example, all the installed C9400-PWR-3200DC modules are configured as standby.

- If power supply modules of different capacities are installed, the higher capacity modules must be configured as standby.

Continuing with the above example, the 3200 W module is the higher capacity module and all installed C9400-PWR-3200DC modules are configured as standby.



Note Regardless of the type of power supply module installed (whether only AC input, or only DC input, or a mix of both types), in the context of the N+N redundant mode, ensure the following:

- When transitioning or switching over to the N+N mode (from any other mode), there must be no change in the power consumption budget during the transition period.
- Total standby output power must be greater than or equal to the total active output power (total standby output power > or = total active output power). This ensures that the system continues to provide redundancy at the time of a switchover.



CHAPTER 3

Preparing for Installation

- [Site Requirements, on page 27](#)
- [Power Requirements, on page 38](#)
- [Cabling Requirements, on page 43](#)
- [Rack-Mounting Guidelines, on page 43](#)
- [Site Preparation Checklist, on page 45](#)

Site Requirements

Planning a proper location for the switch and layout of the equipment rack or wiring closet is essential for successful system operation. These sections describe some of the basic site requirements that you should be aware of as you prepare to install your switch, including the following:

- Environmental factors can adversely affect the performance and longevity of your system.
- Install the switch in an enclosed, secure area, ensuring that only qualified personnel have access to the switch and control of the environment.
- Equipment that is placed too closely together or that is inadequately ventilated may cause system over-temperature conditions, leading to premature component failure.
- Poor equipment placement can make chassis panels inaccessible and difficult to maintain.
- The switch requires a dry, clean, well-ventilated, and air-conditioned environment.
- To ensure normal operation, maintain ambient airflow. If the airflow is blocked or restricted, or if the intake air is too warm, an over-temperature condition may occur. The switch environmental monitor may then shut down the system to protect the system components.
- Multiple switches can be rack mounted with little or no clearance above and below the chassis. However, when mounting a switch in a rack with other equipment, or when placing it on the floor near other equipment, ensure that the exhaust from other equipment does not blow into the air intake vent of the switch chassis.
- If the switch supports 90W PoE, the existing cabling in the building may not be suitable for the switch installation. Reassess the cable plan with a qualified personnel.

For more information, see the *Cabling Requirements* section in this document.

Temperature

Temperature extremes may cause a system to operate at reduced efficiency and cause a variety of problems, including premature aging and failure of chips, and failure of mechanical devices. Extreme temperature fluctuations may also cause chips to become loose in their sockets. Observe the following guidelines:

- Ensure that the system is operating in an environment that is—
 - 27 to 109 °F (-5 to +45 °C) up to 6000 feet (1800m)
 - 27 to 104 °F (-5 to +40 °C) up to 10000 feet (3000m)
- Ensure that the chassis has adequate ventilation.
- Do not place the chassis within a closed-in wall unit or on top of cloth, which can act as thermal insulation.
- Do not place the chassis where it will receive direct sunlight, particularly in the afternoon.
- Do not place the chassis next to a heat source of any kind, including heating vents.
- Do not operate the system if the fan assembly is removed or if it is not functioning properly. An overtemperature condition can cause severe equipment damage or an unscheduled system shutdown.
- Adequate ventilation is particularly important at high altitudes. Make sure that all the slots and openings on the system remain unobstructed, especially the fan vent on the chassis.
- Clean the installation site at regular intervals to avoid buildup of dust and debris, which may cause a system to overheat.
- If system is exposed to abnormally low temperatures, allow a two hour warm up period, in ambient temperature no lower than 32°F (0 °C) before turning on.

Failure to observe these guidelines may damage the chassis' internal components.

Air Flow

The switch is designed to be installed in an environment where there is a sufficient volume of air available to cool the supervisor engines, modules, and power supplies. If there are any constraints with regard to the free flow of air through the chassis, or if the ambient air temperature is elevated, the switch environmental monitor may then shut down the system to protect the system components.

To maintain proper air circulation through the switch chassis, we recommend that you maintain a minimum space of 6 inches (15 cm) between a wall and the chassis and power supply unit air intakes or a wall and the chassis and power supply unit hot air exhausts. In situations where the switch chassis are installed in adjacent racks, you should allow a minimum space of 12 inches (30.5 cm) between the air intake of one chassis and the hot air exhaust of another chassis. Failure to maintain adequate spacing between chassis may cause the switch chassis that is drawing in the hot exhaust air to overheat and fail.

Figure 4: Air Flow Direction - Cisco Catalyst 9400 Series Switches

The figure shows the chassis and power supply air flow directions in a Catalyst 9407R Switch. The same air flow direction applies to all Cisco Catalyst 9400 Series Switches.

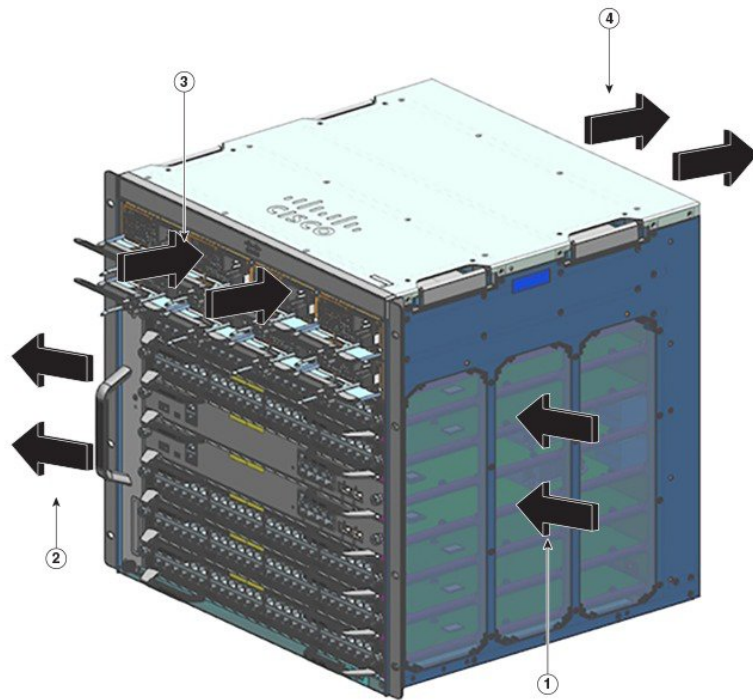

355171

1	Chassis air intake	3	Power supply air intake
2	Chassis air exhaust	4	Power supply air exhaust

If you are installing your switch in an enclosed or partially enclosed rack, we strongly recommend that you verify that your site meets the following guidelines:

- Verify that there is a minimum of 6 inches (15 cm) of clearance between the sides, front, and back of any enclosure, and both the chassis air intake grill and the chassis air exhaust grill along with the power supply unit intakes and exhausts.

Do not use fully closed cabinets or open racks with solid side panels, unless they meet the 6 inch clearance requirements with respect to chassis intake and exhaust vents, or unless the sides incorporate sufficient venting holes.

The upright columns of a relay rack may have less than the recommended side spacing - provided there are substantial cut-outs, holes, or vents in the structure to allow adequate air flow through the chassis. For two-post racks with solid uprights, the recommended maximum column depth for unrestricted air flow is 5 inches (13 cms) for a 23-inch rack and 4 inches (10 cms) for a 19-inch rack.

- Verify that the ambient air temperature within the enclosed or partially enclosed rack is within the chassis operating temperature limits. After installing the chassis in the rack, power up the chassis and allow the chassis temperature to stabilize (approximately 2 hours).

Measure the ambient air temperature at the chassis air intake grill by positioning an external temperature probe 1 inch (2.5 cm) away from the chassis left side, and centered on the chassis both horizontally and vertically.

Measure the ambient air temperature at the power supply unit air intake grill by positioning an external temperature probe 1 inch (2.5 cm) away from the chassis front, centered on the power supply unit section located above the card slots.

- If the ambient intake air temperature is less than 109°F (45°C) at altitudes of 6,000 feet and below, the rack meets the intake air temperature criterion. At altitudes above that threshold and up to 10,000 feet (3000 m), the air intake should not exceed 104°F (40°C).
 - If the ambient intake air temperature exceeds this recommendation, the system may experience minor temperature alarms and increase fan speeds in response.
 - If the ambient intake air temperature equals or is greater than 131°F (55°C), the system may experience a major temperature alarm with maximum fan speeds in response. If ambient temperature continues to increase, system will respond with protective shut down.
- Plan ahead. A switch that is currently installed in an enclosed or partially enclosed rack might meet ambient air temperature and air flow requirements at present. However, if you add more chassis to the rack or more modules to a chassis in the rack, the additional heat generated might cause the ambient air temperature at the chassis or power supply unit inlets to exceed recommended conditions which may trigger thermal alarms.

If installation conditions for inlet temperature and airflow are marginal or not fully met, activate the fan tray's NEBS mode, which has more aggressive programming to address restricted spacing and elevated ambient temperatures. This should result in reduced thermal alarms along with greater acoustic noise and increased power consumption associated with higher fan speeds.

Humidity

High-humidity conditions may cause moisture to enter the system, and cause corrosion of internal components and degradation of properties such as electrical resistance, thermal conductivity, physical strength, and size. Extreme moisture buildup inside the system may result in electrical short circuit, which may cause serious damage to the system. Each system is rated for storage and operation in 10 to 95 percent relative humidity, non-condensing with a humidity gradation of 10 percent per hour. Buildings in which climate is controlled by air-conditioning in the warmer months and by heat during the colder months usually maintain an acceptable level of humidity for system equipment. However, if a system is located in an unusually humid location, a dehumidifier should be used to maintain the humidity within an acceptable range.

Altitude

Operating a system at high altitude (low pressure) reduces the efficiency of forced and convection cooling and may result in electrical problems related to arcing and corona effects. This condition may also cause sealed components with internal pressure, such as electrolytic capacitors, to fail or perform at reduced efficiency.

Dust and Particles

Fans cool power supplies and system components by drawing in room-temperature air and exhausting heated air out through various openings in the chassis. However, fans also ingest dust and other particles, causing contaminant buildup in the system and increased internal chassis temperature. A clean operating environment can greatly reduce the negative effects of dust and other particles, which act as insulators and interfere with the mechanical components in the system.

The standards listed below provide guidelines for acceptable working environments and acceptable levels of suspended particulate matter:

- National Electrical Manufacturers Association (NEMA) Type 1
- International Electrotechnical Commission (IEC) IP-20

Air Quality

Dust is everywhere and often invisible to the naked eye. It consists of fine particles in the air that originate from various sources, such as soil dust lifted by weather, from volcanic eruptions, or pollution. Dust at an installation site may contain small amounts of textile, paper fibers, or minerals from outdoor soil. It may also contain natural contaminants, such as chlorine from the marine environment and industrial contaminants such as sulfur. Ionized dust and debris are dangerous and get attracted to electronic equipment.

The accumulation of dust and debris on electronic equipment has the following adverse effects:

- It increases the operating temperature of the equipment. According to the Arrhenius effect, an increase in the operating temperature leads to a decrease in reliability and life of the equipment.
- The moisture and corrosive elements that are present in the dust can corrode the electronic or mechanical components and cause premature board failure.

These adverse effects are further accelerated by the presence of fans in the data networking equipment that ingest dust and other particles into the equipment. Higher the volume of air that is generated by the fans for cooling, the higher the quantity of dust and particulates that get deposited and trapped inside the equipment. Remove or minimize the presence of dust and particulates at the installation site by following the guidelines mentioned in ANSI 71-04-2013 regulations.



Note In addition to the guidelines mentioned in ANSI 71-04-2013 regulations, follow all applicable guidelines as per site conditions to remove or minimize other contaminants.

Corrosion

Corrosion is a chemical reaction that occurs between electronic components and gases which results in metal deterioration. Corrosion attacks edge connectors, pin connectors, IC plug-in sockets, wirewraps, and all other metal components. Depending on the type and concentration level of the corrosive gases, performance degradation of the components occurs either rapidly or over a period of time. It also leads to blocked currents, brittle connection points, and overheated electrical systems. Corrosion by-products form insulating layers on circuits and causes electronic failure, short circuits, pitting, and metal loss.

A type of corrosion known as creep corrosion, that primarily affects PCBA (Printed Circuit Board Assembly) occurs when the PCBA is subjected to a harsh, and sulfur-rich (hydrogen sulfide) end-use environment over a prolonged period of time. The corrosion begins on certain exposed metals, such as copper and silver, and then creeps along the remaining metal surface either causing electrical short circuits or creating holes. Creep corrosion also occurs on electronic components such as resistors and PCBs.

To prevent corrosion, remove or minimize the presence of dust and particulates at the installation site by following the guidelines mentioned in ANSI 71-04-2013 regulations.

Figure 5: A PCB with Corrosion on its Metal Contacts

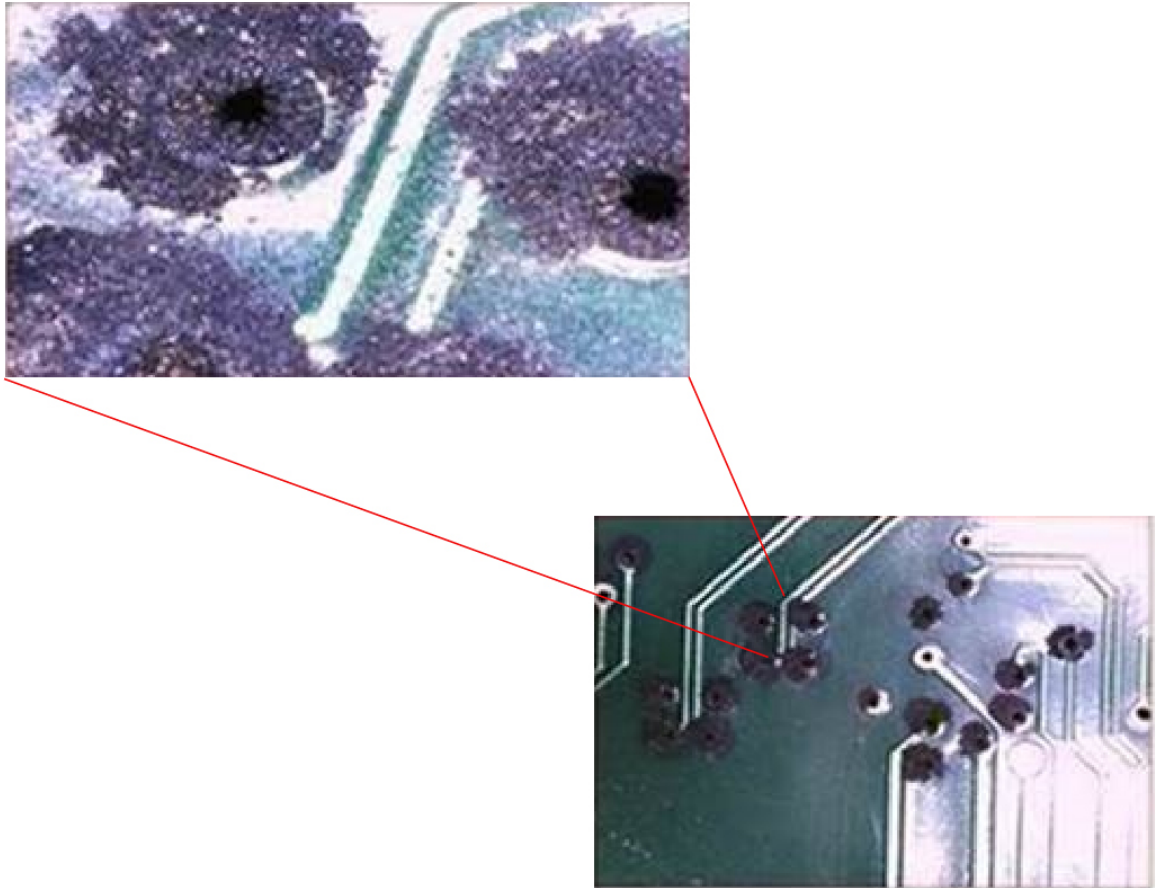

EMI and Radio Frequency Interference

Electro-Magnetic interference (EMI) and radio frequency interference (RFI) from a system can adversely affect devices such as radio and television (TV) receivers operating near the system. Radio frequencies emanating from a system can also interfere with cordless and low-power telephones. Conversely, RFI from high-power telephones can cause spurious characters to appear on the system monitor. RFI is defined as any EMI with a frequency above 10 kilohertz (kHz). This type of interference can travel from the system to other devices through the power cable and power source, or through the air in the form of transmitted radio waves. The Federal Communications Commission (FCC) publishes specific regulations to limit the amount of harmful interference emitted by computing equipment. Each system meets these FCC regulations. To reduce the possibility of EMI and RFI, follow these guidelines:

- Always operate the system with the chassis covers installed.
- Ensure that all chassis slots are covered by a metal filler bracket and that an unused power supply bay has a metal cover plate installed.
- Ensure that the screws on all peripheral cable connectors are securely fastened to their corresponding connectors on the back of the chassis.
- Always use shielded cables with metal connector shells for attaching peripherals to the system.

When wires are run for any significant distance in an electromagnetic field, interference can occur between the field and the signals on the wires. This fact has two implications for the construction of plant wiring:

- Bad wiring practice can result in radio interference emanating from the plant wiring.
- Strong EMI, especially when it is caused by lightning or radio transmitters, can destroy the signal drivers and receivers in the chassis, and even create an electrical hazard by conducting power surges through lines into equipment.



Note To predict and provide a remedy for strong EMI, consult experts in RFI.

If you use twisted-pair cable in your plant wiring, include a good distribution of grounding conductors to reduce EMI. If you exceed the recommended distances, use a high-quality twisted-pair cable with one ground conductor for each data signal when applicable.

If the wires exceed the recommended distances, or if wires pass between buildings, give special consideration to the effect of a lightning strike in your vicinity. The electromagnetic pulse caused by lightning or other high-energy phenomena can easily couple enough energy into unshielded conductors to destroy electronic devices. If you have had problems of this sort in the past, you may want to consult experts in electrical surge suppression and shielding.



Caution The intra-building ports (Copper Based Ethernet Ports) of the equipment or subassembly is suitable for connection to inside a building or unexposed wiring or cabling only. If the intra-building ports of the equipment or subassembly is metalically connected to interfaces that connect to the Out Side Plant (OSP) or its wiring, the metallic-connection **MUST NOT** be more than 6 meters (approximately 20 feet). These interfaces are designed for use as intra-building interfaces only (Type 2, 4, or 4a ports as described in GR-1089-CORE) and require isolation from the exposed OSP cabling. The addition of Primary Protectors is not sufficient protection in order to connect these interfaces metalically to an OSP wiring system.

Shock and Vibration

The equipment complies with the Earthquake, Office, and Transportation Vibration, and Equipment Handling Criteria of GR-63-CORE.

Power Source Interruptions

Systems are especially sensitive to variations in voltage supplied by the AC power source. Overvoltage, undervoltage, and transients (or spikes) can erase data from memory or even cause components to fail. To protect against these types of problems, power wiring ground conductors should always be properly grounded. Also, place the system on a dedicated power circuit (rather than sharing a circuit with other heavy electrical equipment). In general, do not allow the system to share a circuit with any of the following:

- Copy machines
- Air conditioners
- Vacuum cleaners
- Space heaters

- Power tools
- Teletype machines
- Laser printers
- Facsimile machines
- Any other motorized equipment

Besides these appliances, the greatest threats to a system's power supply are surges or blackouts that are caused by electrical storms. Whenever possible, turn off the system and peripherals, if any, and unplug them from their power sources during thunderstorms. If a blackout occurs—even a temporary one—while the system is turned on, turn off the system immediately and disconnect it from the electrical outlet. Leaving the system on may cause problems when the power is restored; all other appliances left on in the area may create large voltage spikes that may damage the system.

System Grounding



Warning Statement 1046—Installing or Replacing the Unit

To reduce risk of electric shock, when installing or replacing the unit, the ground connection must always be made first and disconnected last.

If your unit has modules, secure them with the provided screws.

You must install a system ground as part of the chassis installation process. Chassis installations that rely only on the AC third-prong ground are insufficient to adequately ground the systems.

Proper grounding practices ensure that the buildings and the installed equipment within them have low-impedance connections and low-voltage differentials between chassis. When you install a system ground, you reduce or prevent shock hazards, chances of equipment damage due to transients, and the potential for data corruption.

Without proper and complete system grounding, you run the risk of increased component damage due to ESD. Additionally, you have a greatly increased chance of data corruption, system lockup, and frequent system reboot situations by not using a system ground.



Caution Installations that rely solely on system grounding that uses only an AC third-prong ground run a substantially greater risk of equipment problems and data corruption than those installations that use both the AC third-prong ground and a properly installed system ground.

The following table lists some general grounding practice guidelines.

Table 4: Grounding Practice Guidelines

Environment	Electromagnetic Noise Severity Level	Grounding Recommendations
Commercial building is subjected to direct lightning strikes. For example, some places in the United States, such as Florida, are prone to more lightning strikes than other areas.	High	All lightning protection devices must be installed in strict accordance with manufacturer recommendations. Conductors carrying lightning current should be spaced away from power and data lines in accordance with applicable recommendations and building codes. Best grounding practices must be closely followed.
Commercial building is located in an area where lightning storms occur frequently, but is not prone to direct lightning strikes.	High	Best grounding practices must be closely followed.
Commercial building contains a mix of information technology equipment and industrial equipment, such as welding.	Medium to High	Best grounding practices must be closely followed.
Existing commercial building is not subject to natural environmental noise or man-made industrial noise. This building contains a standard office environment. This installation has a history of malfunction due to electromagnetic noise.	Medium	Best grounding practices must be closely followed. Determine source and cause of noise if possible, and mitigate as closely as possible at the noise source or reduce coupling from the noise source to the victim equipment.
New commercial building is not subject to natural environmental noise or man-made industrial noise. This building contains a standard office environment.	Low	Best grounding practices should be followed as closely as possible. Electromagnetic noise problems are not anticipated, but installing a best-practice grounding system in a new building is often the least expensive route, and the best way to plan for the future.
Existing commercial building is not subject to natural environmental noise or man-made industrial noise. This building contains a standard office environment.	Low	Best grounding practices should be followed as much as possible. Electromagnetic noise problems are not anticipated, but installing a best-practice grounding system is always recommended.



Note In all situations, grounding practices must comply with Section 250 of the National Electric Code (NEC) requirements or local laws and regulations. A 6 AWG grounding wire is preferred from the chassis to the rack ground or directly to the common bonding network (CBN). The equipment rack should also be connected to the CBN with a 6 AWG grounding wire.



Note Grounding lugs must be installed on the location marked on the chassis only.



Note Always ensure that all of the modules are completely installed and that the captive installation screws are fully tightened. In addition, ensure that all the I/O cables and power cords are properly seated. These practices are normal installation practices and must be followed in all installations.

Maintaining Safety with Electricity

When working on electrical equipment, follow these guidelines:

- Do not work alone if potentially hazardous conditions exist anywhere in your work space.
- Never assume that power is disconnected from a circuit; always check the circuit before working on it.
- When the power is switched off, put a lock-box on the circuit, so that no one can accidentally switch it on.
- Look carefully for possible hazards in your work area, such as damp floors, ungrounded power extension cables, frayed or damaged power cords, and missing safety grounds.
- If an electrical accident occurs, proceed as follows:
 - Use extreme caution; do not become a victim yourself.
 - Disconnect power from the system.
 - Seek medical attention, if necessary.
- Use the product within its marked electrical ratings and product usage instructions.
- Install the product in compliance with local and national electrical codes.
- If any of the following conditions occur, contact the Cisco Technical Assistance Center:
 - The power cable or plug is damaged.
 - An object has fallen into the product.
 - The product has been exposed to water or other liquids.
 - The product has been dropped or shows signs of damage.
 - The product does not operate correctly when you follow the operating instructions.

- Use the correct external power source. Operate the product only from the type of power source indicated on the electrical ratings label. If you are not sure of the type of power source required, consult a local electrician.
- For AC-input power supply modules, you have been provided with one or more power cables with your chassis power supply that are intended for use in your country, based on the shipping location. Should you need to purchase additional power cables, ensure that they are rated for the product and for the voltage and current marked on the product's electrical ratings label. The voltage and current rating of the power cable should be greater than the ratings marked on the label.

For DC-input power supply modules, you must obtain the required cables; they are not shipped with the power supply module. Ensure that cable lengths, wire gauges, and lug sizes meet the chassis requirements, site-specific installation requirements, as well your local electric codes. See the [Required Tools and Equipment](#) section for further guidance.

- To help prevent electrical shock, plug all the power cables into properly grounded electrical outlets. These power cables are equipped with three-prong plugs to ensure proper grounding. Do not use adapter plugs or remove the grounding prong from a power cable.
- Observe power strip ratings. Make sure that the total current rating of all products that are plugged into the power strip does not exceed 80 percent of the power strip rating.
- Do not modify power cables or plugs yourself. Consult with a licensed electrician or your power company for site modifications. Always follow your local and national wiring codes.

Preventing ESD Damage

ESD damage might occur when modules or other FRUs are improperly handled, resulting in intermittent or complete failure of the modules or FRUs. Modules consist of printed circuit boards that are fixed in metal carriers. EMI shielding and connectors are integral components of a carrier. Although the metal carrier helps to protect the board from ESD, always use an ESD-grounding strap when handling modules. To prevent ESD damage, follow these guidelines:

- Always use an ESD wrist or ankle strap and ensure that it makes good skin contact.
- Connect the equipment end of the strap to an unfinished chassis surface.
- When installing a component, use an available ejector lever or captive installation screws to properly seat the bus connectors in the backplane or midplane. These devices prevent accidental removal, provide proper grounding for the system, and help to ensure that bus connectors are properly seated.
- When removing a component, use an available ejector lever or captive installation screws to release the bus connectors from the backplane or midplane.
- Handle carriers by available handles or edges only; avoid touching the printed circuit boards or connectors.
- Place a removed component board-side-up on an antistatic surface or in a static-shielding container. If you plan to return the component to the factory, immediately place it in a static-shielding container.
- Avoid contact between the printed circuit boards and clothing. The wrist strap only protects components from ESD voltages on the body; ESD voltages on clothing can still cause damage.
- Never attempt to remove the printed circuit board from the metal carrier.

Power Requirements

Power supply modules installed on a switch chassis can be all AC input, all DC input, or a mix of both. When preparing your site for switch installation, adhere to these requirements:

- In systems that are configured with more than one power supply, connect each of the power supplies to a separate input power source. If you fail to do this, your system might be susceptible to total power failure due to a fault in the external wiring or a tripped circuit breaker.
- To prevent loss of input power, ensure that the total maximum load on each source circuit is within the current ratings of the wiring and breakers.
- In some systems, you may decide to use a UPS to protect against power failures at your site. When selecting a UPS, be aware that some models, which use ferroresonant technology, may become unstable when operating with the switch power supplies that use power factor correction. This may cause the output voltage waveform to the switch to become distorted, resulting in an undervoltage situation in the system.

Power Connection Guidelines for AC-Powered Systems

When connecting AC-input power supply modules to the site power source, observe the guidelines described here.



Warning **Statement 1028**—More Than One Power Supply

This unit might have more than one power supply connection. To reduce risk of electric shock, remove all connections to de-energize the unit.



-
- Ensure that the AC-input power supply module has a detachable power cord.
 - Each chassis power supply should have a separate, dedicated branch circuit.
 - North America
 - C9400-PWR-3200AC only—Power supply modules require a 20 A circuit.
 - C9400-PWR-2100AC only—Power supply modules require a 15 A circuit.
 - International—Circuits should be sized according to local and national codes.
 - If you are using a 208 or 240 VAC power source in North America, note that such lines are considered hot and the circuit must be protected by a two-pole circuit breaker.



Warning Statement 1005—Circuit Breaker

This product relies on the building's installation for short-circuit (overcurrent) protection. To reduce risk of electric shock or fire, ensure that the protective device is rated not greater than these values for the U.S. and EU:

- 20 A circuit breaker for an AC-input power supply module.
 - 50 A DC-rated circuit breaker for each input of a DC-input power supply module, for safety purposes - irrespective of whether the inputs are power from a single or separate DC sources.
-



Warning Statement 1022—Disconnect Device

To reduce the risk of electric shock and fire, a readily accessible disconnect device must be incorporated in the fixed wiring.

- The source AC outlet must be within 9.84 to 14 feet (3.0 to 4.293 meters) of the system - depending on the length of the power cord, and should be easily accessible.
- The AC power receptacles used to plug in the chassis must be the grounding type. The grounding conductors that connect to the receptacles should connect to protective earth ground at the service equipment level.

Power Connection Guidelines for DC-Powered Systems

When connecting DC-input power supply modules to the site power source, observe the guidelines described here.



Warning Statement 1003—DC Power Disconnection

To reduce risk of electric shock or personal injury, disconnect DC power before removing or replacing components or performing upgrades.



Warning Statement 1022—Disconnect Device

To reduce the risk of electric shock and fire, a readily accessible disconnect device must be incorporated in the fixed wiring.



Warning Statement 1024—Ground Conductor

This equipment must be grounded. To reduce the risk of electric shock, never defeat the ground conductor or operate the equipment in the absence of a suitably installed ground conductor. Contact the appropriate electrical inspection authority or an electrician if you are uncertain that suitable grounding is available.



Warning Statement 1028—More Than One Power Supply

This unit might have more than one power supply connection. To reduce risk of electric shock, remove all connections to de-energize the unit.

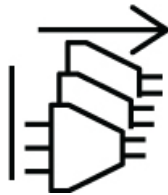

Warning Statement 1033—Safety Extra-Low Voltage (SELV)—IEC 60950/ES1—IEC 62368 DC Power Supply

To reduce the risk of electric shock, connect the unit to a DC power source that complies with the SELV requirements in IEC 60950-based safety standards or ES1 and PS1 requirements in IEC 62368-based safety standards or to a Class 2 power supply.



Warning Statement 1046—Installing or Replacing the Unit

To reduce risk of electric shock, when installing or replacing the unit, the ground connection must always be made first and disconnected last.

If your unit has modules, secure them with the provided screws.

- All power connection wiring should conform to the rules and regulations prescribed by the National Electrical Code (NEC), as well as local codes, if any.

- The DC return must remain isolated from the system frame and the chassis (DC-I).

The color coding of the source DC power cable leads depends on the color coding of the site DC power source. Typically, green or green and yellow stripes indicate that the cable is a ground cable. Since there is no color code standard for source DC wiring, you must ensure that the power cables are connected to the DC-input power supply terminal block in the proper + and - polarity.

In some cases, the source DC cable leads might have a positive (+) or a negative (–) label. This label is a relatively safe indication of polarity, but you must verify the polarity by measuring the voltage between the DC cable leads. When measuring, ensure that the positive lead and the negative lead always match the "+" and "-" labels on the DC-input power supply terminal block, respectively.

- DC power cables must be terminated by cable lugs at the power supply end.
-

- The circuit must be protected by a dedicated two-pole DC-rated circuit breaker.

The circuit breaker is considered to be the disconnect device and must be easily accessible. For DC-input power supply modules with multiple inputs, each DC input must be protected by a dedicated DC-rated circuit breaker or a fuse.

The circuit breaker or fuse should be sized according to the power supply input rating and local or national code requirements.

This product requires short-circuit (overcurrent) protection, to be provided as part of the building installation. Install only in accordance with national and local wiring regulations.



Warning Statement 1005—Circuit Breaker

This product relies on the building's installation for short-circuit (overcurrent) protection. Ensure that the protective device is rated not greater than these values for the U.S. and EU:

- 20 A circuit breaker for an AC-input power supply module.
- 50 A DC-rated circuit breaker for each input of a DC-input power supply module, for safety purposes - irrespective of whether the inputs are power from a single or separate DC sources.

-
- If the DC inputs are powered from separate sources, the cables must be wired straight across to their respective sources and terminals.

Crossed cables in a setup where the DC source has floating outputs means that no damage will occur, but the LEDs will not light up, and the module will not operate.

Crossed cables in a setup with a positive ground or a negative ground power system constitute a severe safety hazard that includes causing electric shock and generating excessive EMI and RFI.

The following illustrations show the correct installation with two separate sources of DC power and a single source of DC power:

Figure 6: C9400-PWR-3200DC Installation Example: Separate DC Sources

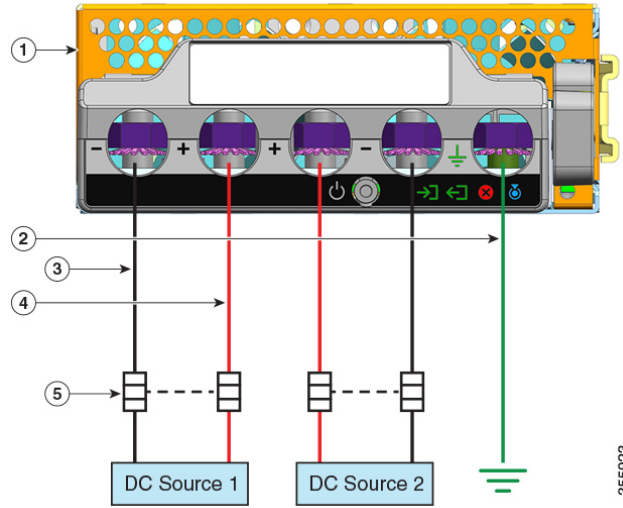

1	C9400-PWR-3200DC	4	Cable for positive circuit
2	Safety ground connection	5	Dual-pole circuit breaker
3	Cable for negative circuit	-	-

Figure 7: C9400-PWR-3200DC Installation Example - Single DC Source

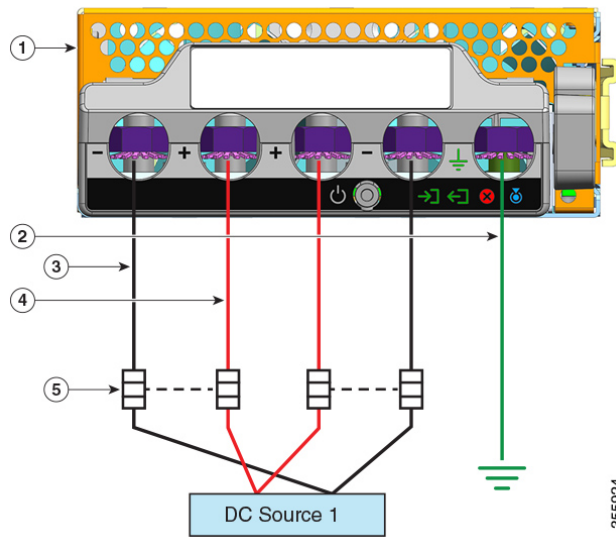

1	C9400-PWR-3200DC	4	Cable for positive circuit*
2	Safety ground connection	5	Dual-pole circuit breaker
3	Cable for negative circuit*	-	-



Note * In the illustration, the red and black cables do not interconnect. The two black cables are connected to the same negative output of the DC source; the two red cables are connected to the same positive output of the DC source.

Cabling Requirements

When running power and data cables together in overhead cable trays or subfloor cable trays, be aware of the following caution:



Caution We strongly recommend that power cabling runs and other potential noise sources be located as far away as practical from LAN cabling that terminates on Cisco equipment. In situations where this type of long parallel cable runs exist and cannot be separated by at least 3.3 feet (1 meter), we recommend that you shield these potential noise sources. To avoid interference, the source should be shielded by housing it in a grounded metallic conduit.

For IEEE 802.3bt Type 4 installations, we recommend using Category 6a cables, rated at 75°C with conductors 23AWG or larger, in bundle sizes of 192 or less.

If your installation does not use the recommended cable, following are the other options that are compliant to National Electrical Code (NEC):

- Other Category cables (like Category 5e, or Category 6 cables) rated at 75°C, with conductors 23AWG, in bundle sizes of 192 or less.
- Limited Power (-LP) cable with 0.6A
- Cables with conductors 23AWG, rated at 60°C, in bundle sizes of 61 or less
- Cables with conductors 24AWG, rated at 75°C, in bundle sizes of 91 or less
- Cables with conductors 24AWG, rated at 60°C, in bundle sizes of 37 or less

For a detailed analysis on the recommended cabling, refer [Analysis of Cabling Requirements for IEEE 802.3bt Type 4 Devices](#).

Rack-Mounting Guidelines

Rack Specifications

Cisco Catalyst 9400 Series Switches are designed to be installed in standard, 19-inch equipment racks that meet EIA-310-D specifications. Before rack-mounting the chassis, ensure that the equipment rack complies with all requirements and guidelines

Mounting Location Guidelines

Cisco Catalyst 9400 Series Switches must be front-mounted.

Accordingly, you can install the chassis in 2-post or 4-post racks, but in a 4-post rack, the rear posts are not used for mounting.

Width and Depth Requirements

Use a tape measure to verify the interior dimensions of the rack

- Measure the space between the inner edges of the left front and right front mounting posts. The chassis is 17.30 inches (43.942 cm) wide and must fit between the mounting posts.
- Measure the depth of the rack from the outside of the front mounting posts to the outside of the rear mounting strip. The chassis is 16.30 inches (41.40 cm) deep.

Height Requirements

The rack must have sufficient clearance in terms of height, to insert the chassis. Chassis height is also measured in rack units (RU or just U) where 1 RU or 1 U equals 1.75 inches (44.45 mm). A typical server rack is 42 RU or 42 U in height.

The chassis heights are as follows:

- The Catalyst 9404R Switch chassis height—10.5 inches (26.67 cms)—6 RU.
- The Catalyst 9407R Switch chassis height—17.41 inches (44.22 cms)—10 RU.
- The Catalyst 9410R Switch chassis height—22.61 inches (57.43 cms)—13 RU.

Other General Guidelines



Caution If the equipment rack is on wheels, ensure that the brakes are engaged and that the rack is stabilized.



Warning **Statement 1006**—Chassis Warning for Rack-Mounting and Servicing

To prevent bodily injury when mounting or servicing this unit in a rack, you must take special precautions to ensure that the system remains stable. The following guidelines are provided to ensure your safety:

- This unit should be mounted at the bottom of the rack if it is the only unit in the rack.
 - When mounting this unit in a partially filled rack, load the rack from the bottom to the top with the heaviest component at the bottom of the rack.
 - If the rack is provided with stabilizing devices, install the stabilizers before mounting or servicing the unit in the rack.
-



Warning **Statement 1047**—Overheating Prevention

To reduce the risk of fire or bodily injury, do not operate the unit in an area that exceeds the maximum recommended ambient temperature of: 104°F (40°C)



Note To maintain proper air circulation through the switch chassis, we recommend that you maintain a minimum space of 6 inches (15 cm) between a wall and the chassis and power supply unit air intakes or a wall and the chassis and power supply unit hot air exhausts. In situations where the switch chassis are installed in adjacent racks, you should allow a minimum space of 12 inches (30.5 cm) between the air intake of one chassis and the hot air exhaust of another chassis. Failure to maintain adequate spacing between chassis may cause the switch chassis that is drawing in the hot exhaust air to overheat and fail.

Site Preparation Checklist

The following table lists the site-planning activities that you should perform prior to installing the switch. Completing each activity helps ensure a successful switch installation.

Table 5: Site Preparation Checklist

Task No.	Activity	Verified By	Time	Date
1	Space evaluation <ul style="list-style-type: none"> • Space and layout • Floor covering • Impact and vibration • Lighting • Maintenance access 			
2	Environmental evaluation <ul style="list-style-type: none"> • Ambient temperature • Humidity • Altitude • Atmospheric contamination • Airflow 			
3	Power evaluation <ul style="list-style-type: none"> • Input power type • Power receptacles (Depends on power supply)¹ • Receptacle proximity to the equipment. • Dedicated (separate) circuits for redundant power supplies. • UPS for power failures² 			

Task No.	Activity	Verified By	Time	Date
4	Grounding evaluation <ul style="list-style-type: none"> • Circuit breaker size • CO ground (AC powered systems) 			
5	Cable and interface equipment evaluation <ul style="list-style-type: none"> • Cable type • Connector type • Cable distance limitations • Interface equipment (transceivers) • Cable bundling sizes 			
6	EMI evaluation <ul style="list-style-type: none"> • Distance limitations for signaling • Site wiring • RFI levels 			

¹ Verify that each power supply installed in the chassis has a dedicated AC source circuit.

² Refer to the power supply VA rating as a sizing criteria in determining the output required by the UPS. The power supply kVA rating value is listed in the specifications table for each power supply in Appendix A (power supply specifications).



CHAPTER 4

Standard Accessory Kit Contents

Switch Model	Standard Accessory Kit Part Number
Catalyst 9404R Switch	C9404-ACC-KIT=
Catalyst 9407R Switch	C9407-ACC-KIT=
Catalyst 9410R Switch	C9410-ACC-KIT=

Cisco Catalyst 9400 Series Switches ship with a standard accessory kit, which includes the following items:

Item	Quantity
12-24 x 0.75 inch M, Phillips screws	12
10-32 x 0.75 inch M, Phillips screws	12
Adapter, DB9F/RJ45F	1
Disposable ESD wrist strap	1
Grounding lug (no.10, with 2 holes), 6 AWG size	1
M4 x 8mm Phillips pan-head screws	2
Fabricated plastic cable management guide	2
Pointer Card	1



CHAPTER 5

Installing the Switch

- [Installation Tasks](#) , on page 49
- [Unpacking the Switch](#), on page 53
- [Install the Switch as Shipped](#), on page 53
- [Install the Switch with Shelf Brackets](#), on page 56
- [Installing the Cable Guide](#), on page 69
- [Install the Switch in a NEBS-Compliant Mode](#), on page 74
- [Establishing System Ground](#), on page 83
- [Attaching an ESD Strap](#), on page 85
- [Verifying the Switch Chassis Installation](#), on page 88

Installation Tasks

These warnings apply to the overall switch installation process:



Warning **Statement 1071**—Warning Definition

IMPORTANT SAFETY INSTRUCTIONS

Before you work on any equipment, be aware of the hazards involved with electrical circuitry and be familiar with standard practices for preventing accidents. Read the installation instructions before using, installing, or connecting the system to the power source. Use the statement number at the beginning of each warning statement to locate its translation in the translated safety warnings for this device.

SAVE THESE INSTRUCTIONS



Warning **Statement 1008**—Class 1 Laser Product

This product is a Class 1 laser product.



Warning Statement 1017—Restricted Area

This unit is intended for installation in restricted access areas. Only skilled, instructed, or qualified personnel can access a restricted access area.



Warning Statement 1024—Ground Conductor

This equipment must be grounded. To reduce the risk of electric shock, never defeat the ground conductor or operate the equipment in the absence of a suitably installed ground conductor. Contact the appropriate electrical inspection authority or an electrician if you are uncertain that suitable grounding is available.



Warning Statement 1028—More Than One Power Supply

This unit might have more than one power supply connection. To reduce risk of electric shock, remove all connections to de-energize the unit.

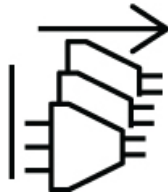

Warning Statement 1032—Lifting the Chassis

To prevent personal injury or damage to the chassis, never attempt to lift or tilt the chassis using the handles on modules, such as power supplies, fans, or cards. These types of handles are not designed to support the weight of the unit.



Warning Statement 9001—Product Disposal

Ultimate disposal of this product should be handled according to all national laws and regulations.



Warning Statement 1046—Installing or Replacing the Unit

To reduce risk of electric shock, when installing or replacing the unit, the ground connection must always be made first and disconnected last.

If your unit has modules, secure them with the provided screws.



Warning **Statement 1051**—Laser Radiation

Invisible laser radiation may be emitted from disconnected fibers or connectors. Do not stare into beams or view directly with optical instruments.



Warning **Statement 1074**—Comply with Local and National Electrical Codes

To reduce risk of electric shock or fire, installation of the equipment must comply with local and national electrical codes.

The process of installing the switch can be broken down into a series of tasks as shown in the following figure:



Note This section illustrates the installation of a Catalyst 9407R Switch switch. All Cisco Catalyst 9400 Series Switches are installed in the equipment rack, the same way.

Further, the equipment racks shown below are for instructional purposes only. For proper operation, ensure that the racks you use comply with site requirements and air flow requirements as stated in the *Preparing for Installation* section of this document.

Figure 8: Installation Tasks

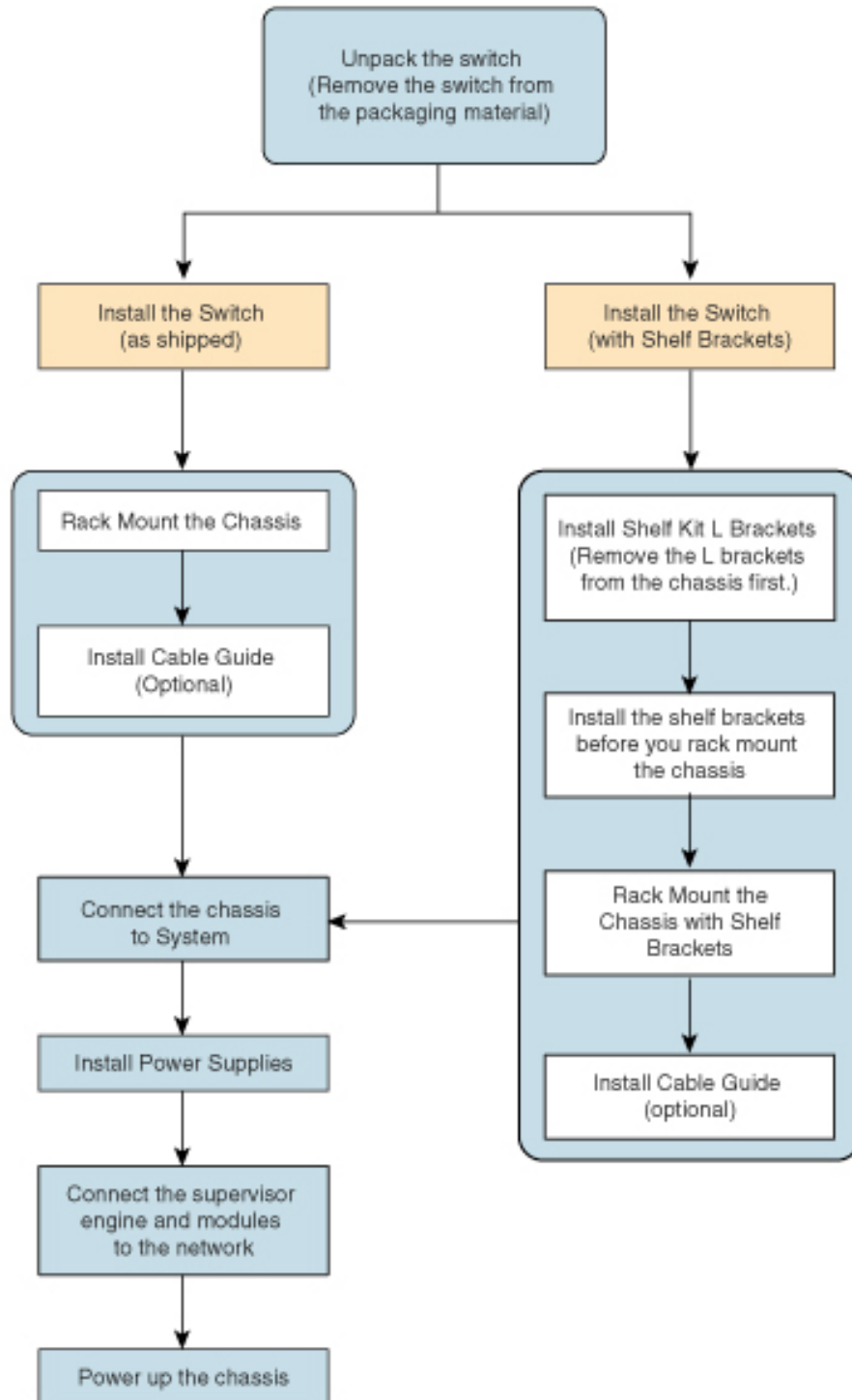

345398

Unpacking the Switch

Check the contents of the shipping container:

Procedure

-
- Step 1** Check the contents of the accessory kit. Verify that you have received all the listed equipment, including any optional equipment you may have ordered, such as, network interface cables, transceivers, or special connectors.
- Step 2** Check the modules in each slot. Ensure that the configuration matches the packing list and that all of the specified interfaces are included.
- Step 3** Store the shipping carton.
- Tip** Do not discard the shipping container when you unpack the switch. Flatten the shipping cartons and store them with the pallet. You will require these containers if you have to move or ship the switch in the future.
-

Install the Switch as Shipped

Rack-Mounting the Chassis as Shipped

This procedure shows how to rack mount the chassis as shipped.

Before you begin



Warning **Statement 1006**—Chassis Warning for Rack-Mounting and Servicing

To prevent bodily injury when mounting or servicing this unit in a rack, you must take special precautions to ensure that the system remains stable. The following guidelines are provided to ensure your safety:

- This unit should be mounted at the bottom of the rack if it is the only unit in the rack.
 - When mounting this unit in a partially filled rack, load the rack from the bottom to the top with the heaviest component at the bottom of the rack.
 - If the rack is provided with stabilizing devices, install the stabilizers before mounting or servicing the unit in the rack.
-

Cable guide installation options have been described in a separate topic. If you are installing the cable guide, read this procedure and the cable guide installation procedure, before you start.

Procedure

- Step 1** Insert the rear of the chassis between the mounting posts of the rack.
- Step 2** Align the mounting holes in the L bracket on the switch with the mounting holes in the equipment rack.

Figure 9: Securing the Chassis to the Rack Posts

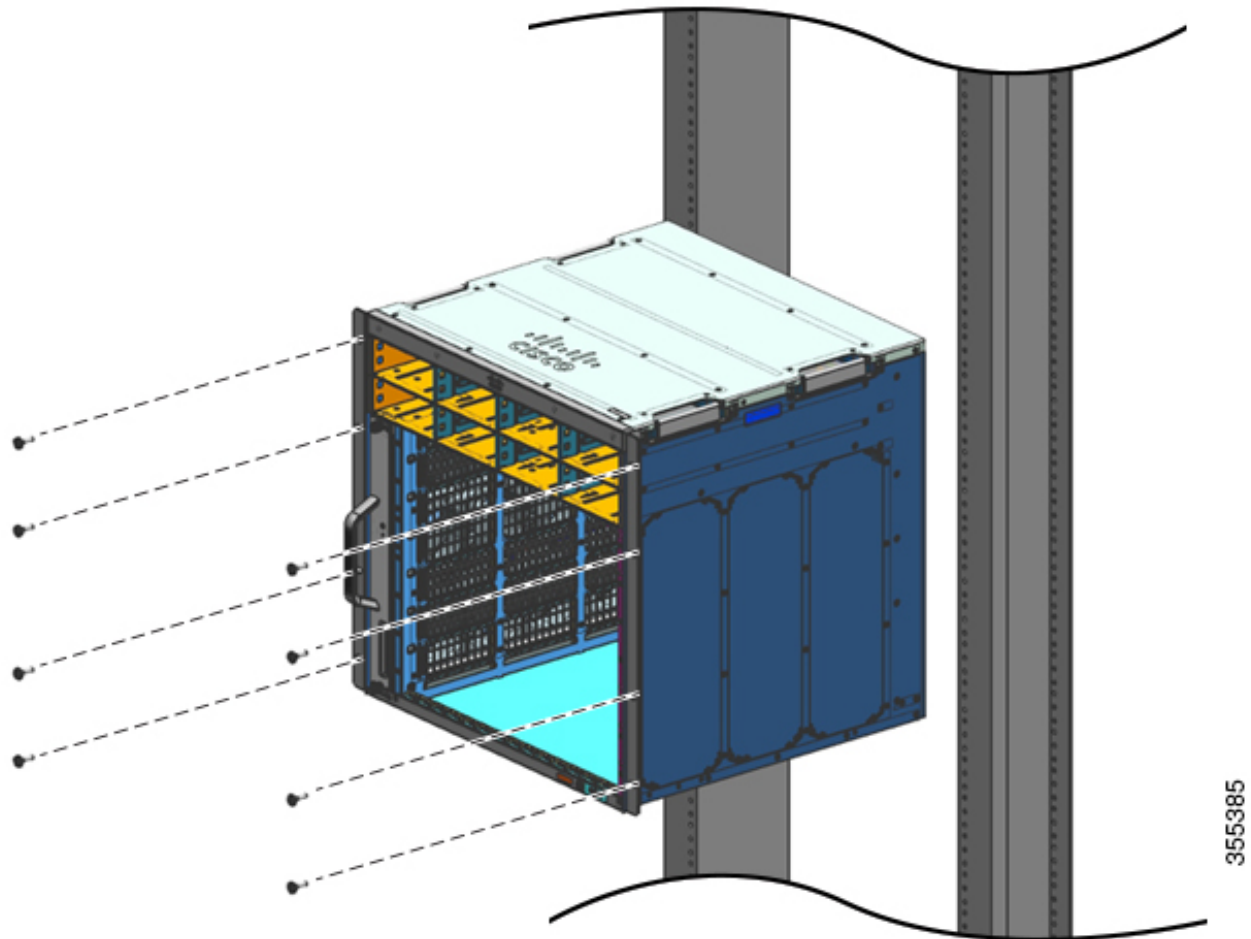

- Step 3** Secure the chassis to the rack with either 10-32 or 12-24 pan head screws from the chassis standard accessory kit.

Figure 10: Chassis Secured to the Rack Posts

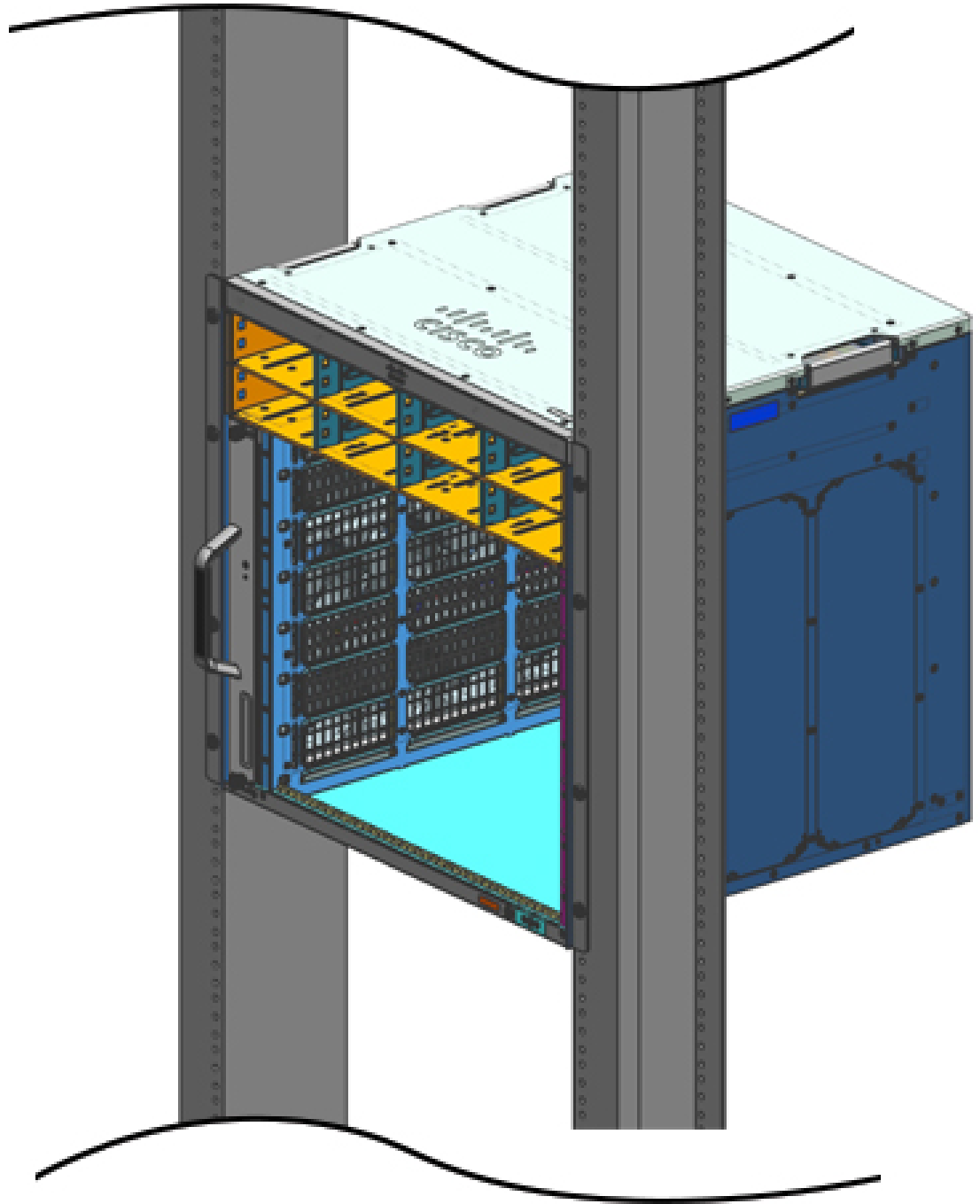

- Step 4** 4. Use a tape measure and level to ensure that the chassis is installed straight and level..

What to do next

After installing the chassis in its location, complete the installation process by:

1. Connecting the chassis to system ground.
2. Installing and connecting the power supplies to the power source.
3. Connecting the network interface cables to the supervisor module and line card modules. This may involve installing transceivers before you attach the network interface cables.
4. Powering up the chassis and verifying the installation.

Install the Switch with Shelf Brackets

Shelf Kit Contents



Note The shelf kit is not part of the standard accessory kit. You must order it separately by using the chassis-specific part number.

Switch Model	Shelf Kit Part Number
Catalyst 9404R Switch	C9404-SHELF-KIT=
Catalyst 9407R Switch	C9407-SHELF-KIT=
Catalyst 9410R Switch	C9410-SHELF-KIT=

The following table lists the contents of the shelf kit:

Table 6: Shelf Kit Contents

Item and Description	Quantity (C9404-SHELF-KIT=)	Quantity (C9407-SHELF-KIT=)	Quantity (C9410-SHELF-KIT=)
Left L bracket. Fabricated metal chassis L bracket, to secure the chassis to the rack enclosure.	1	1	1
Right L bracket. Fabricated metal chassis L bracket, to secure the chassis to the rack enclosure	1	1	1
Shelf brackets Fabricated metal, rack shelf brackets, to support the weight of the chassis.	2	2	2

Item and Description	Quantity (C9404-SHELF-KIT=)	Quantity (C9407-SHELF-KIT=)	Quantity (C9410-SHELF-KIT=)
12-24 x 0.75-inch Phillips screws	6	6	6
10-32 x 0.75-inch Phillips screws	6	6	6
M4 x 8 mm Phillips flat head screws	4	8	10
Documentation, pointer card Provides references to related documentation on cisco.com	1	1	1

Installing the Shelf Kit L Brackets

The switch chassis is shipped with two L brackets installed on the front sides of the chassis. If you are rack-mounting the switch using the Shelf accessory, these L brackets must be removed and replaced with L brackets that are part of the shelf kit

Before you begin

You have ordered and received the shelf kit.

Procedure

-
- Step 1** Remove and discard the L brackets and the ten mounting screws that the chassis is shipped with. Do not re-use them during any part of the installation process.

Figure 11: L Brackets the Chassis is Shipped With

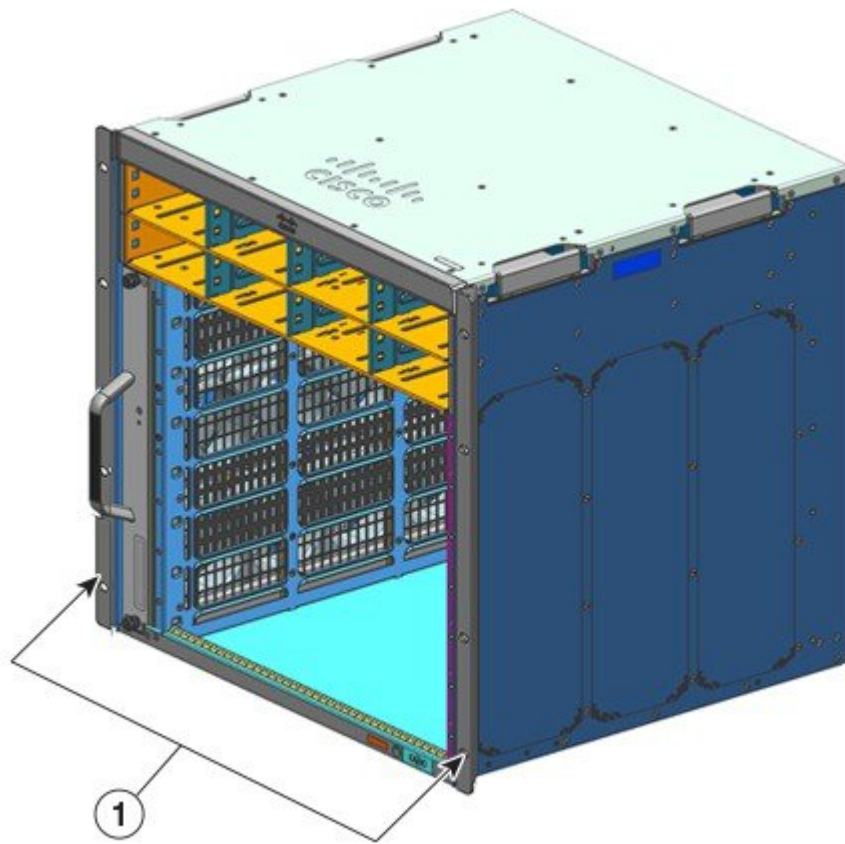

1	L Brackets that the chassis is shipped with	-	-
---	---	---	---

Figure 12: Removing L Brackets the Chassis is Shipped With

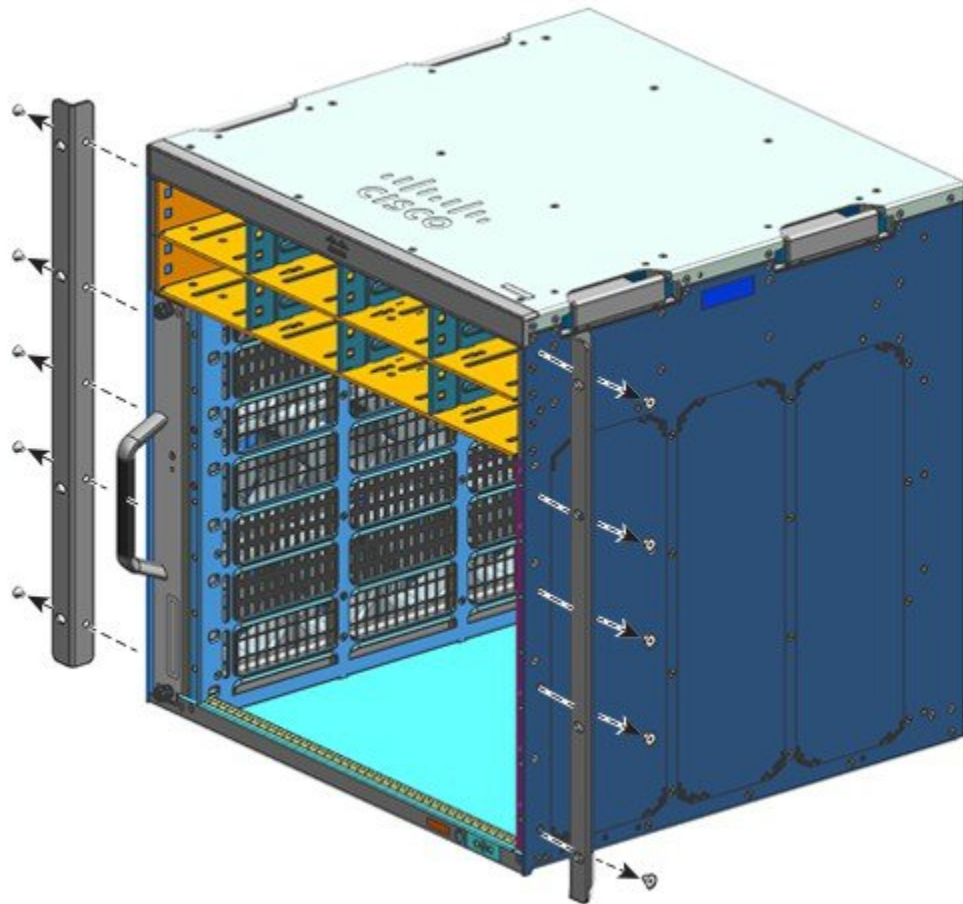

355123

Figure 13: Chassis Without L brackets

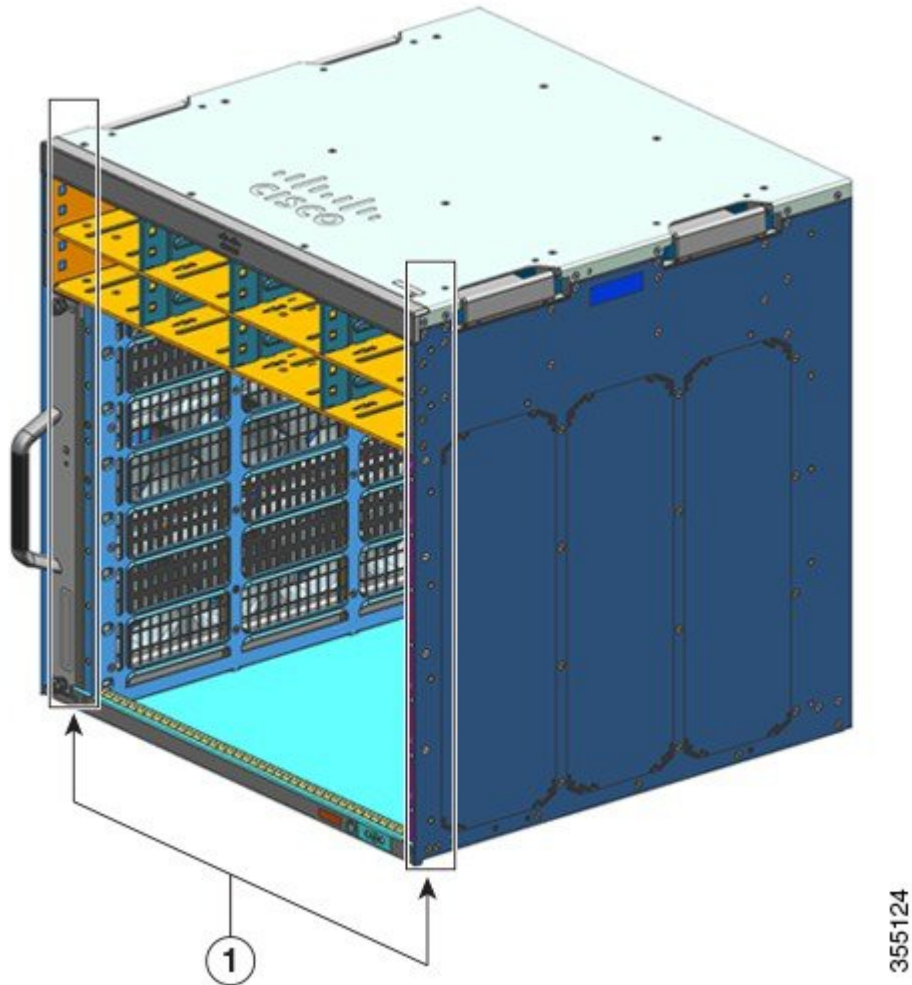

1	Chassis without L brackets	-	-
---	----------------------------	---	---

Step 2 Remove the L brackets from the shelf kit packaging.

Step 3 Using the M4 x 8 mm Phillips flat head screws in the shelf kit, secure the L brackets to the front-left and front-right sides of the chassis (four on each side).

Figure 14: Installing Shelf Kit L Brackets

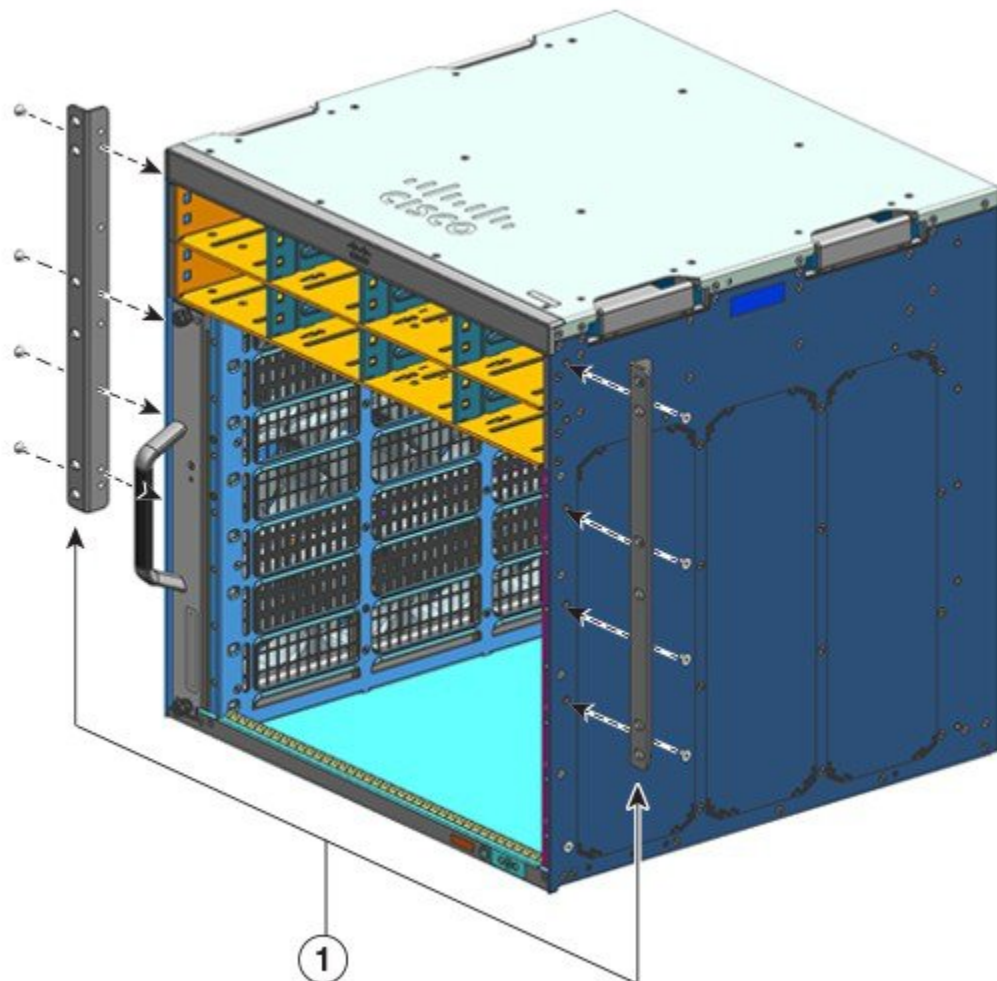

What to do next

Mount the shelf brackets on the rack.

Installing the Shelf Brackets

Install the shelf brackets before you install the chassis in the rack. The shelf brackets attach directly to the rack and help support the weight of the chassis while you secure the L brackets to the rack enclosure.

You have to front-mount the shelf brackets.

Before you begin

Determine the clearance between the insides of the left and right rails of your rack system and install the shelf brackets accordingly. Keep these tools handy:

- Number 1 and Number 2 Phillips screwdrivers
- 3/16-inch flat-blade screwdriver
- Tape measure and level

Procedure

Step 1 Position the support flange of the left shelf bracket on the front of the left rail. Align and secure the bracket to the rack by using three screws. Use either 10-32 or 12-24 pan head screws from the shelf kit.

Step 2 Position the support flange of the right shelf bracket on the front of the right rail — make sure that it is level with the left shelf bracket. Align and secure the bracket to the rack by using three screws.

Use the same type of screws for the left and right shelf bracket.

Figure 15: Installing the Shelf Brackets

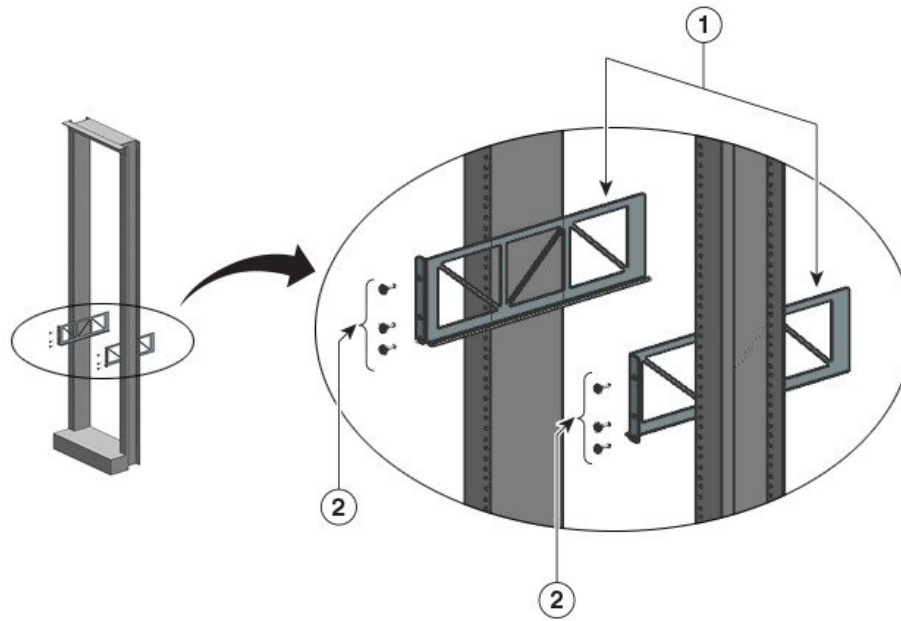

355126

1	Shelf brackets	2	Pan head screws from the shelf kit that secure the shelf brackets to the rack posts
---	----------------	---	---

The shelf brackets are now securely mounted to the rack posts

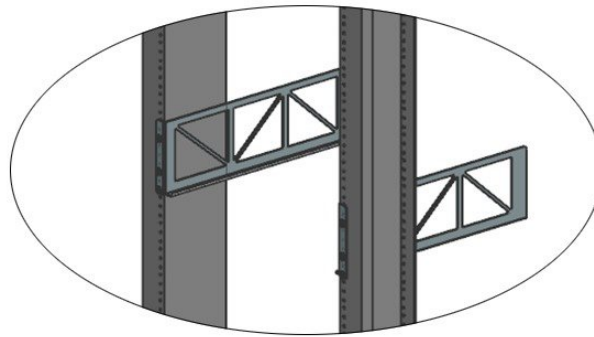

955127

What to do next

Rack-mount the chassis. Two people will be required for this task.

Rack-Mounting the Chassis

This procedure shows how to rack mount the chassis with shelf brackets.



Warning Statement 1098—Lifting Requirement

Two people are required to lift the heavy parts of the product. To prevent injury, keep your back straight and lift with your legs, not your back.



Tip We recommend that you have a third person to assist in this procedure.

To install the switch chassis in the equipment rack, perform these steps:

Before you begin

Warning Statement 1006—Chassis Warning for Rack-Mounting and Servicing

To prevent bodily injury when mounting or servicing this unit in a rack, you must take special precautions to ensure that the system remains stable. The following guidelines are provided to ensure your safety:

- This unit should be mounted at the bottom of the rack if it is the only unit in the rack.
 - When mounting this unit in a partially filled rack, load the rack from the bottom to the top with the heaviest component at the bottom of the rack.
 - If the rack is provided with stabilizing devices, install the stabilizers before mounting or servicing the unit in the rack.
-
- Install the shelf kit L brackets on the chassis and the shelf brackets on the rack posts.

- Cable guide installation options have been described in a separate topic. If you are installing the cable guide, read this procedure and the cable guide installation procedure, before you start.

Procedure

Step 1 Pull out all four of the handholds

Figure 16: Chassis handholds

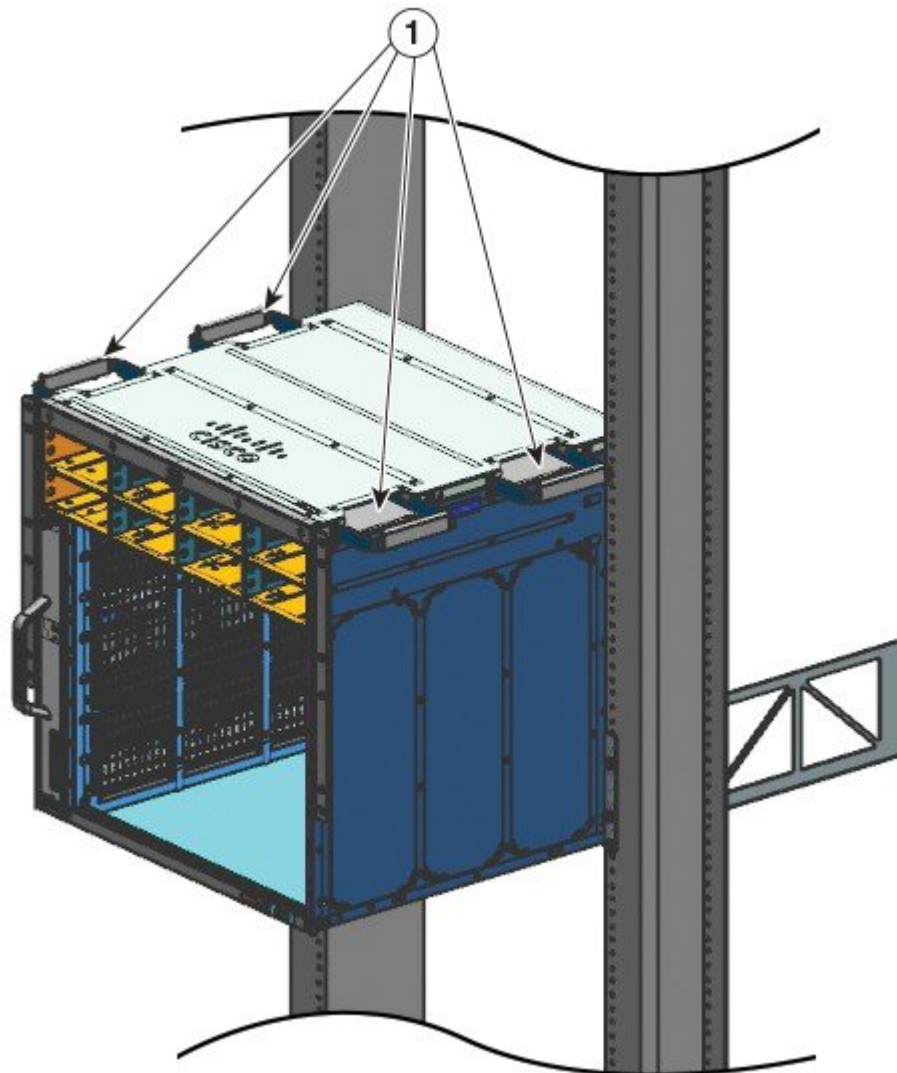

355138

1	All four of the chassis handholds pulled out and the back end of the chassis resting on the edges of the shelf bracket rails.	-	-
---	---	---	---

- Step 2** With a person standing at each side of the chassis, insert one hand into each handhold. Slowly lift the chassis. Avoid sudden twists or moves to prevent injury.
- Step 3** Rest the back end of the chassis on the edges of the shelf bracket rails and slide it in until the first pair of handles on both sides of the chassis are near the rack posts.
- Step 4** Push in the handholds that are closest to the rack posts

Figure 17: Sliding the Chassis in - Part 1

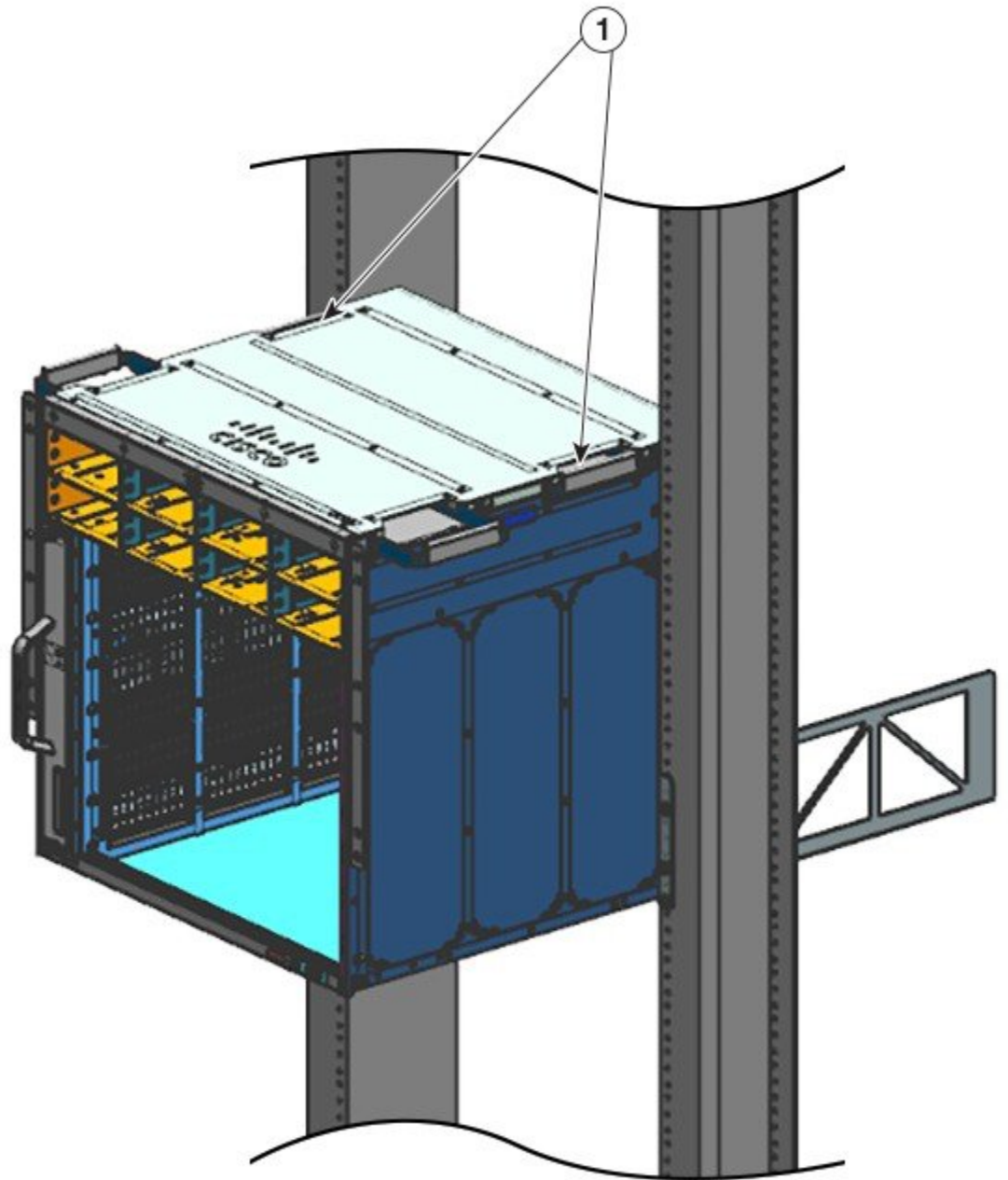

355139

1	Handholds closest to the rack posts, pushed in.	-	-
---	---	---	---

Step 5 Continue sliding the chassis in until the second pair of handholds are near the rack posts

Figure 18: Sliding the Chassis in - Part 2

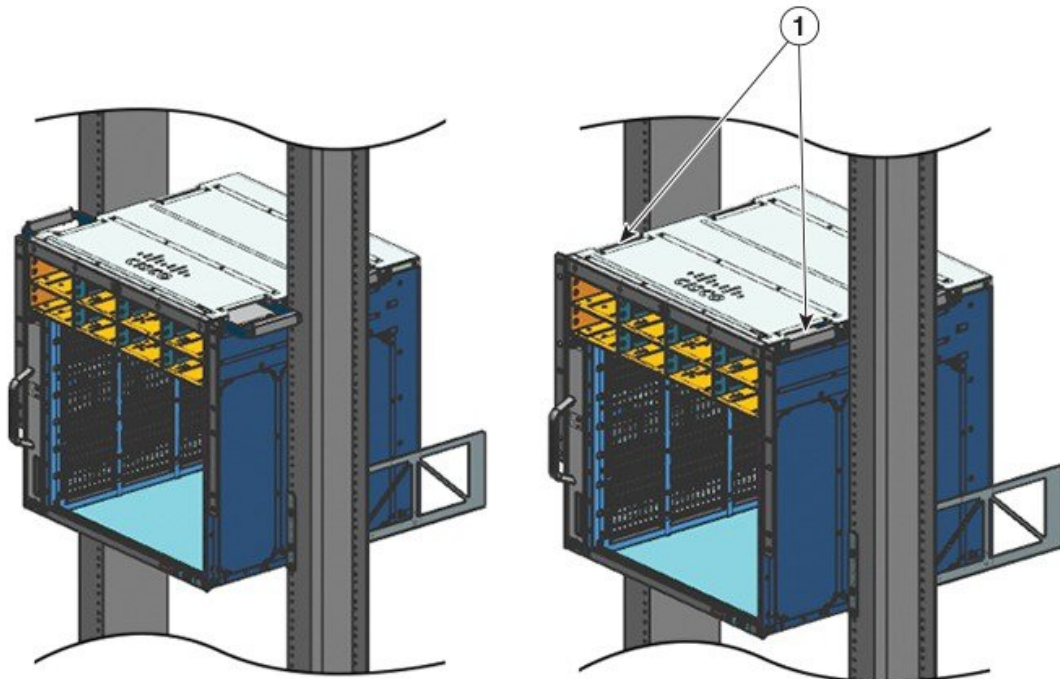

355130

1	Chassis is slid in until the second pair of handholds are near the rack posts.	-	-
---	--	---	---

Step 6 Push in the the second pair of handholds and continue sliding the chassis in until the L brackets make contact with the rack posts.

Step 7 Secure the chassis to the rack with either the 10-32 or 12-24 pan head screws from the chassis standard accessory kit.

Figure 19: Securing the Chassis to the Rack Posts

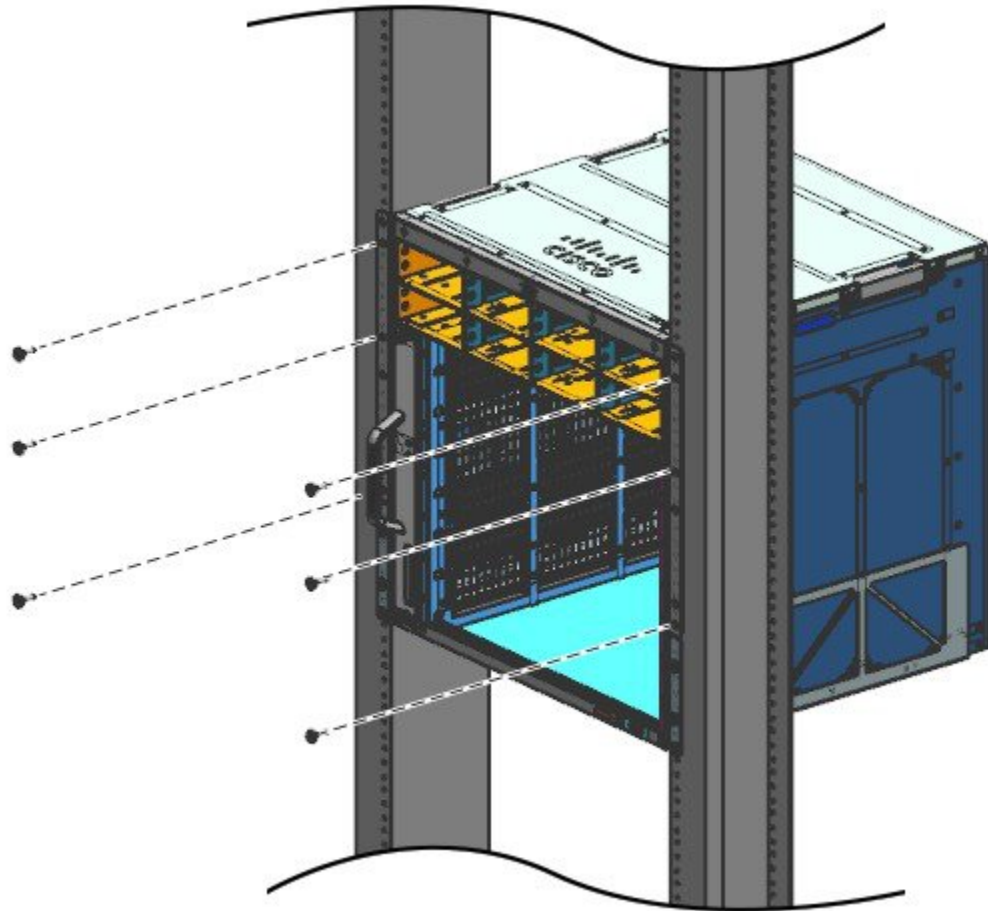

355131

Figure 20: Chassis Secured to the Rack Posts

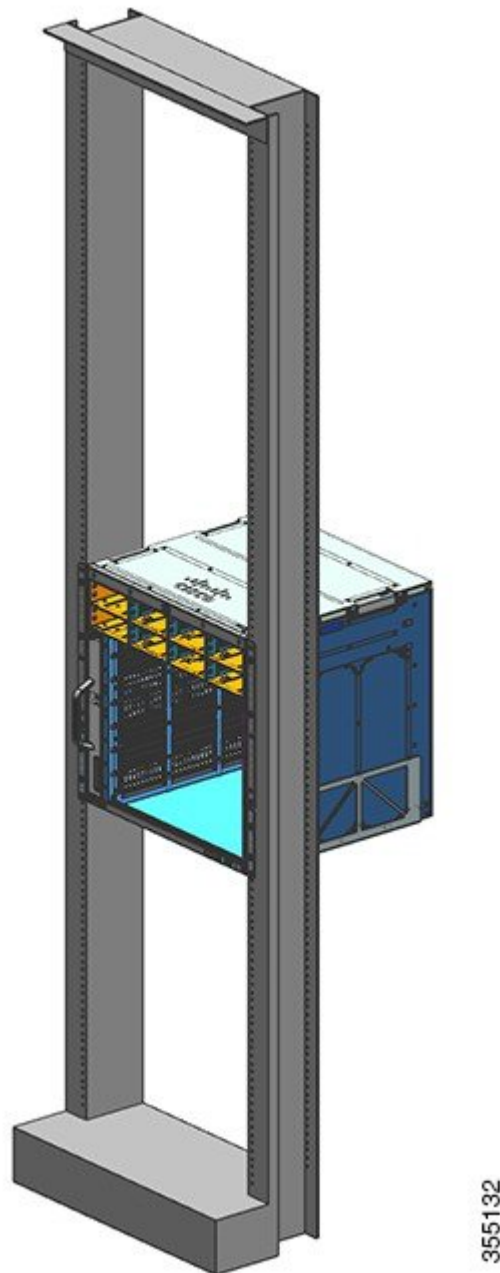

What to do next

After installing the chassis in its location, complete the installation process by:

1. Connecting the chassis to system ground.
2. Installing and connecting the power supplies to the power source.

3. Connecting the network interface cables to the supervisor module and line card modules. This may involve installing transceivers before you attach the network interface cables.
4. Powering up the chassis and verifying the installation.

Installing the Cable Guide

You can install cable guides with or without the shelf brackets. Follow the corresponding procedure:



Note Cable guides are part of the standard accessory kit.



Note You can install cable guides in a NEBS-Compliant set up as well.

Installing the Cable Guide With Shelf Brackets

Procedure

- Step 1** Mount the shelf brackets with only two screws on each side

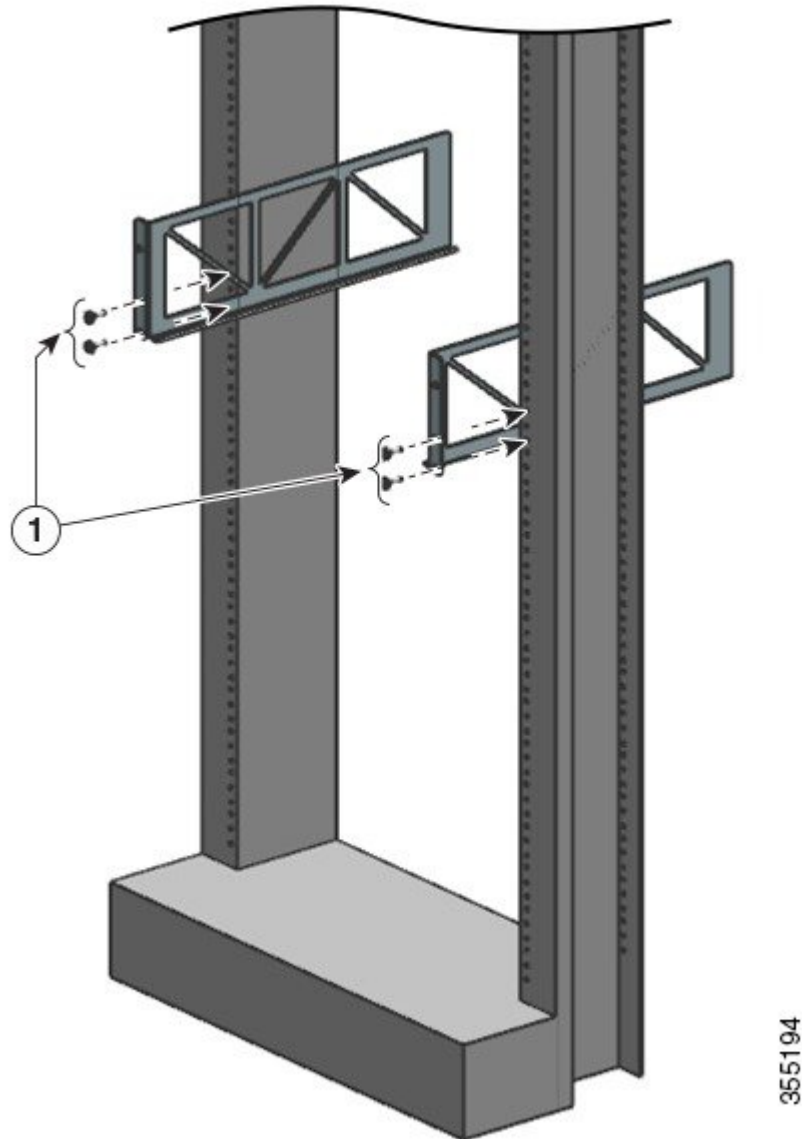

355194

Step 2 Using only one screw on each side, secure the L bracket to the rack rails.

Step 3 Position the cable guides and align with the L brackets and shelf brackets.

Using one screw on each side, align the cable guide mounting holes with the shelf bracket holes and the rack rail holes,

Using two screws on each side, align the cable guide mounting holes with the L bracket holes and the rack rail holes.

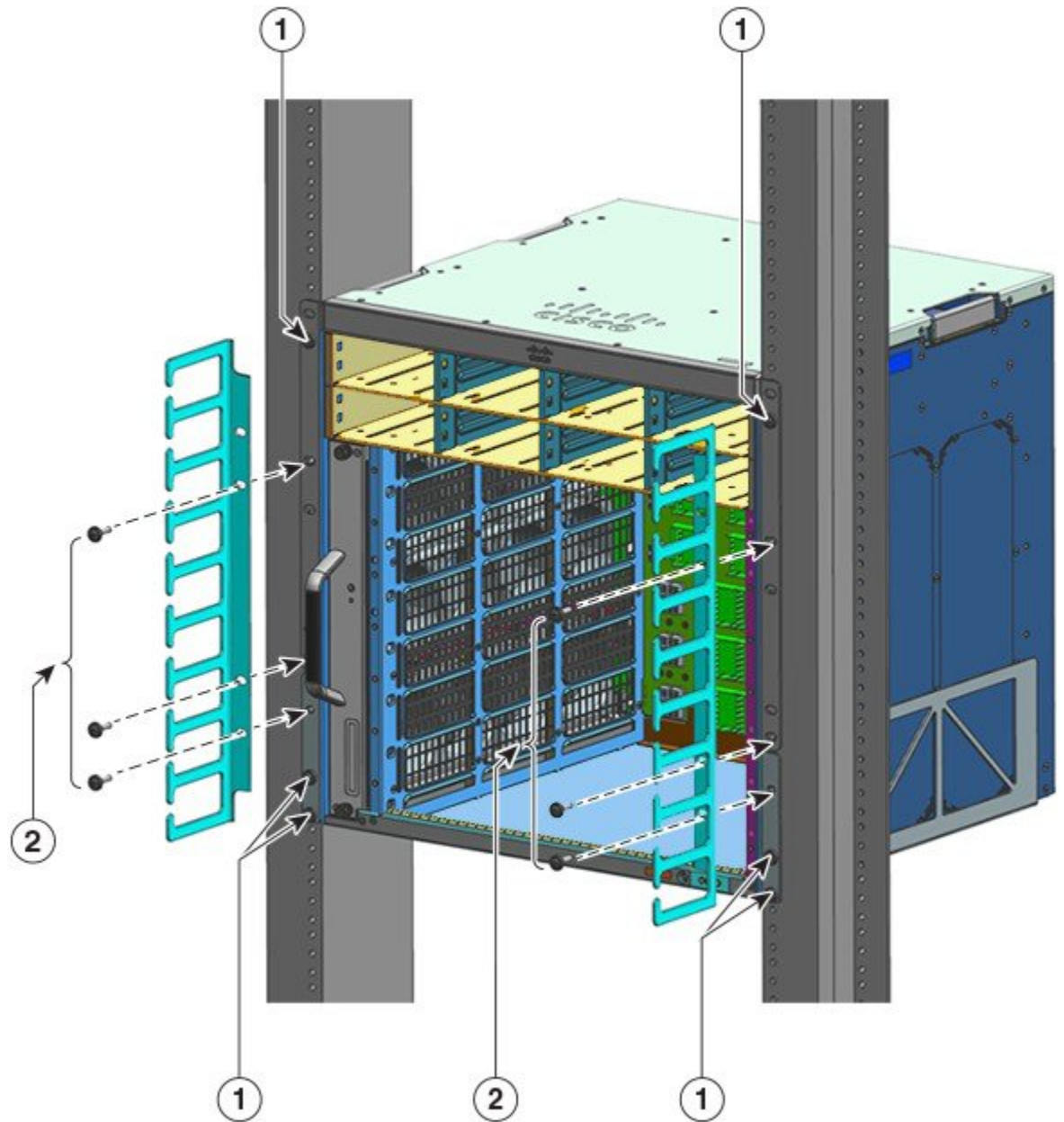

1	Screws that are mounted before the cable guide is—two on each side for the shelf bracket and one on each side for the L bracket.	2	Remaining screws that are mounted when installing the cable guide—one on each side for the shelf bracket and two on each side for the L bracket.
---	--	---	--

Cable guide installation with shelf brackets is complete.

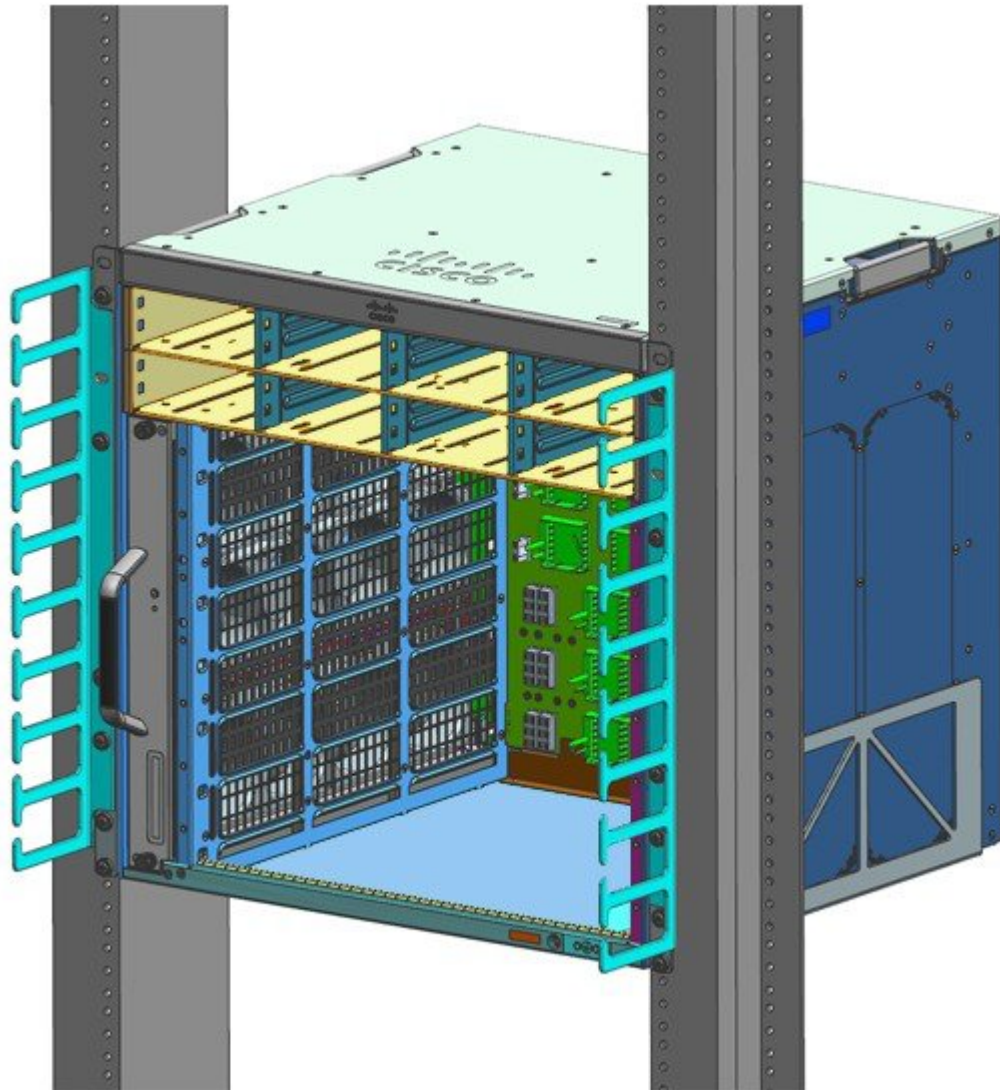

355190

Installing the Cable Guide Without Shelf Brackets

Procedure

- Step 1** Secure the chassis to the rack rails with only two screws on each side.
- Step 2** Position the cable guides and align with the L brackets.

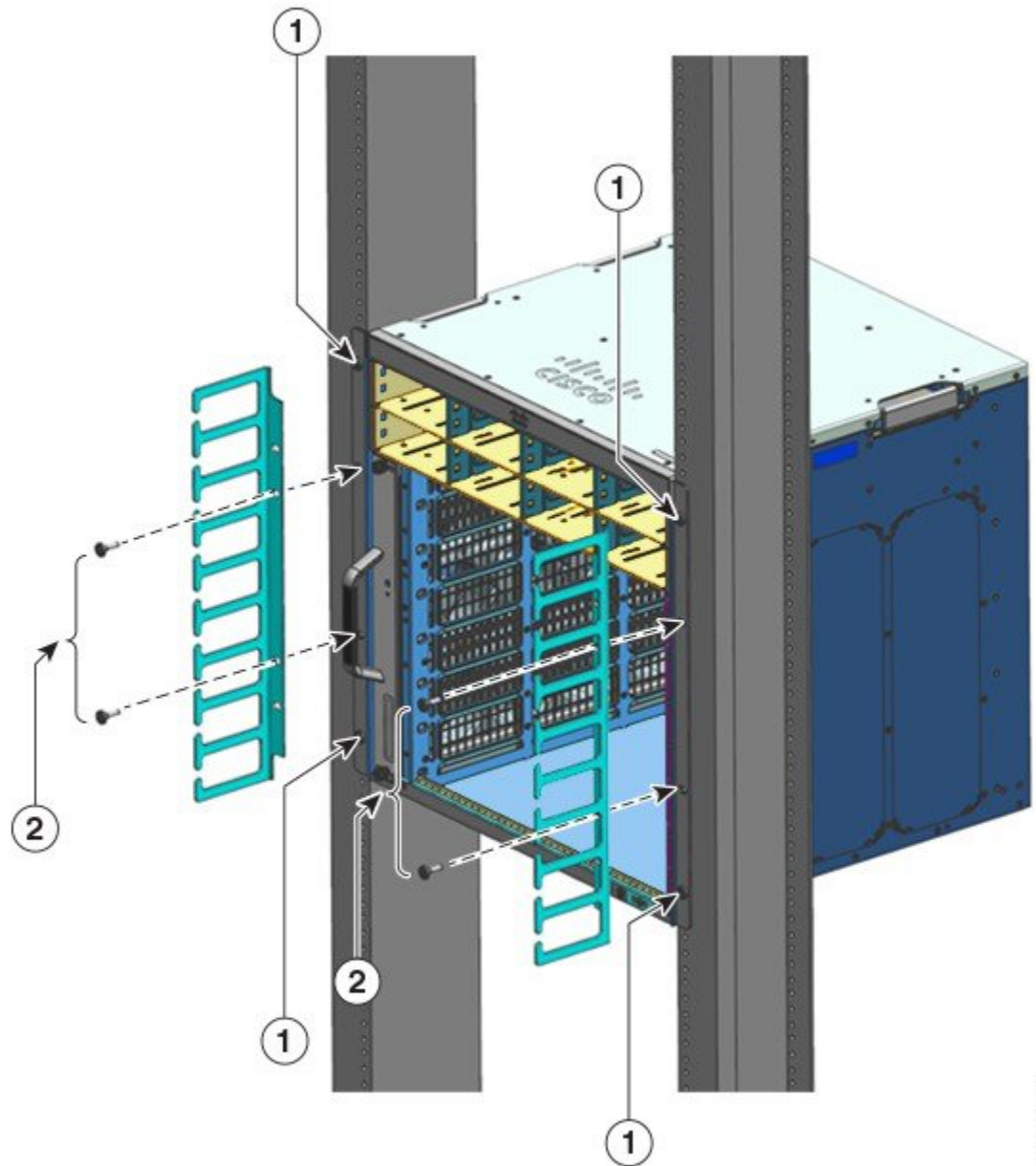

355192

1	Screws that are mounted before the cable guide is—two on each side, securing the L bracket to the rack rails.	2	Remaining screws that are mounted when installing the cable guide—two on each side, aligning and securing the cable guide and L bracket to the rack rails.
---	---	---	--

Cable guide installation without shelf brackets is complete.

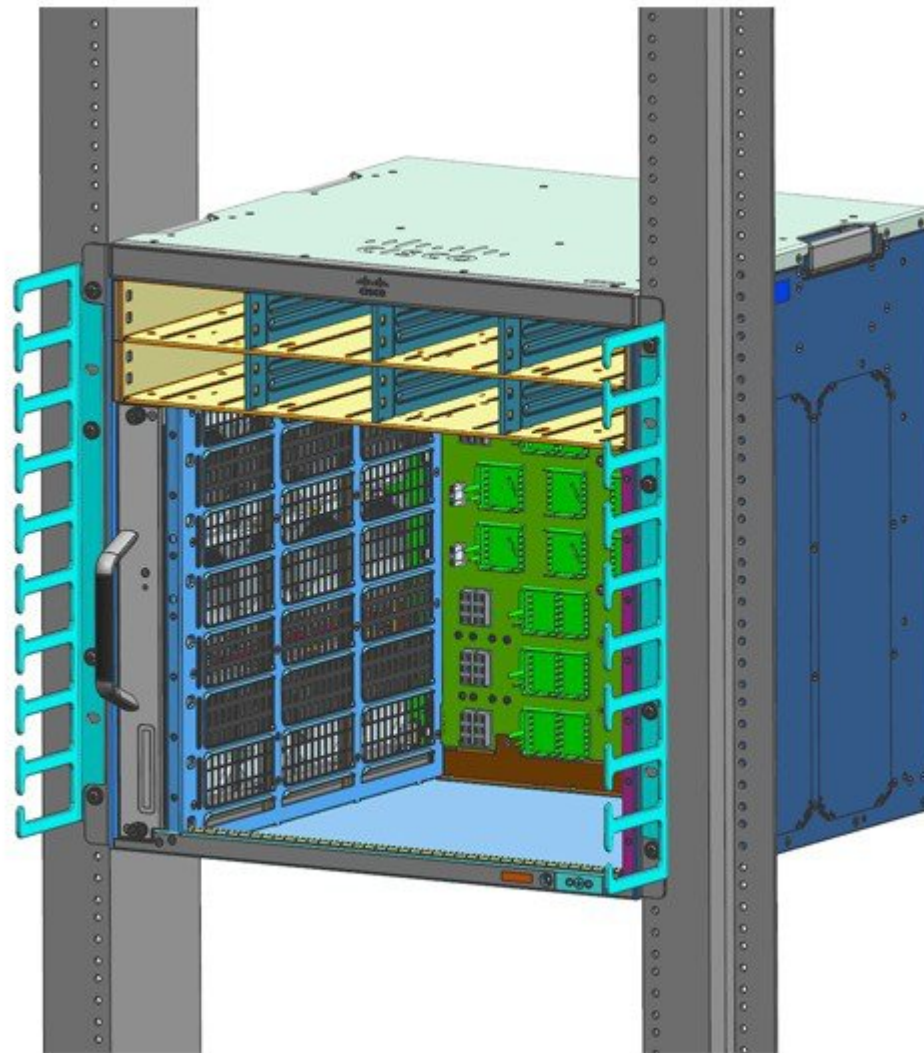

355193

Install the Switch in a NEBS-Compliant Mode

NEBS-Compliant Air Filter

A Network Equipment-Building System (NEBS) compliant installation allows filtered, front-to-rear airflow. To mount the chassis in a NEBS-compliant mode with the air filter, use a 23-inch rack mount. Filter brackets that are mounted on the side of the chassis hold the air filter. For more details on the air filter, refer step 6 of [Rack-Mounting the Chassis in a NEBS-Compliant Mode](#), on page 75 section.



Note In order to meet GR-63-CORE requirements, the switch must be installed in a NEBS-Compliant Mode.

A 23-inch rack mount is used for mounting the switch in a standard 23 inch (58.4 cm) equipment rack with two unobstructed outer posts. This kit is not suitable for racks with obstructions (such as a power strip) that could impair access to the field-replaceable units (FRUs) of the switch.

Table 7: 23 Inch Rack Mount Kit Part Numbers

Switch Model	23-Inch Rack Mount Kit Part Number
Catalyst 9404R Switch	C9404-FB-23-KIT=
Catalyst 9407R Switch	C9407-FB-23-KIT=
Catalyst 9410R Switch	C9410-FB-23-KIT=

Table 8: 23 Inch Rack Mount Kit Contents

Quantity	Parts Description
2	Rack Mounts
6	M4 Phillips pan-head screws
6	12-24 x 3/4-inch Phillips binder-head screws

Rack-Mounting the Chassis in a NEBS-Compliant Mode



Warning Statement 1006—Chassis Warning for Rack-Mounting and Servicing

To prevent bodily injury when mounting or servicing this unit in a rack, you must take special precautions to ensure that the system remains stable. The following guidelines are provided to ensure your safety:

- This unit should be mounted at the bottom of the rack if it is the only unit in the rack.
- When mounting this unit in a partially filled rack, load the rack from the bottom to the top with the heaviest component at the bottom of the rack.
- If the rack is provided with stabilizing devices, install the stabilizers before mounting or servicing the unit in the rack.

Before you begin

Prepare for the installation as follows:

- Place the chassis on the floor or on a sturdy table as close as possible to the rack. Leave enough clearance to allow you to move around the chassis.
- Open the rack-mount kit and verify that all parts are included.



Note Some equipment racks provide a power strip along the length of one of the rear posts. If your rack has this feature, consider the position of the strip when planning fastener points. Before installing the brackets on the chassis, determine whether to install the chassis from the front or the rear of the rack.

Procedure

Step 1 Remove and discard the mounting ears and the ten mounting screws of the chassis. Do not reuse them during any part of the installation process.

Figure 21: Remove the Mounting Ears

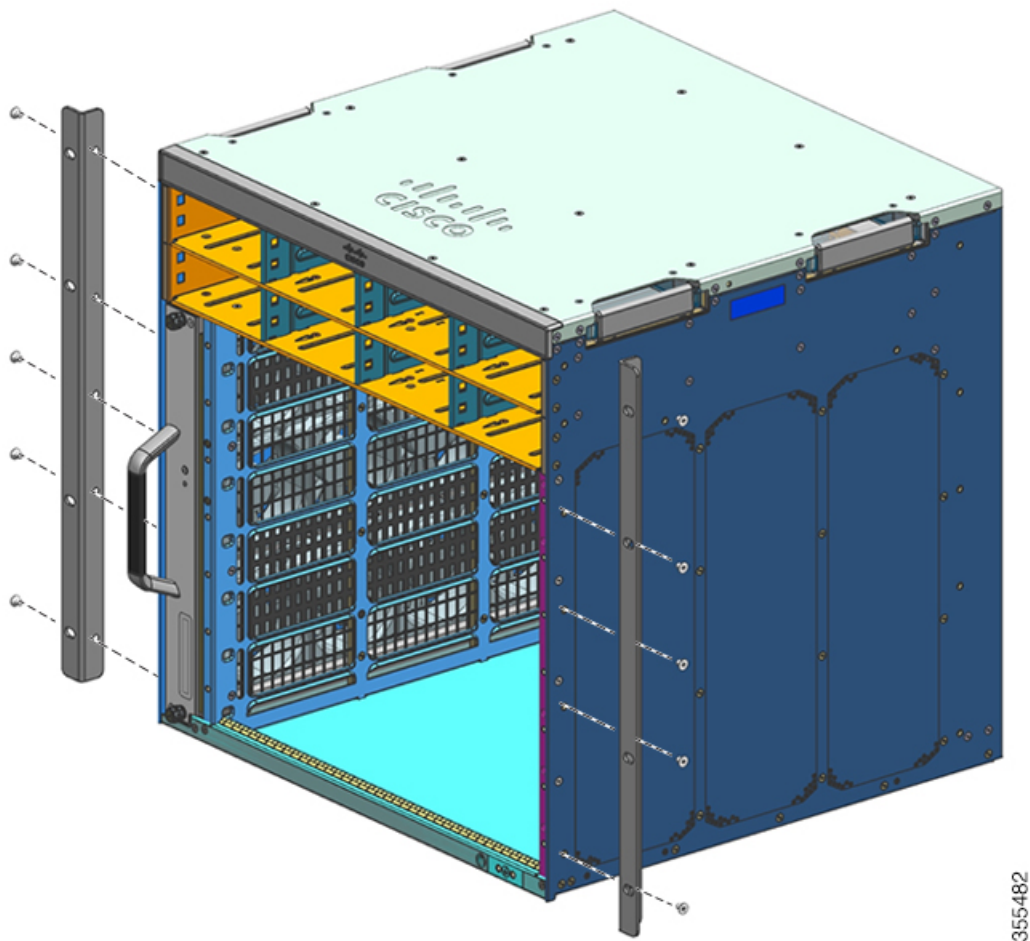

Step 2 Install the rack ear brackets on the left and right sides of the chassis. These brackets connect the chassis to the rack.

Figure 22: Install the Rack Ear Brackets

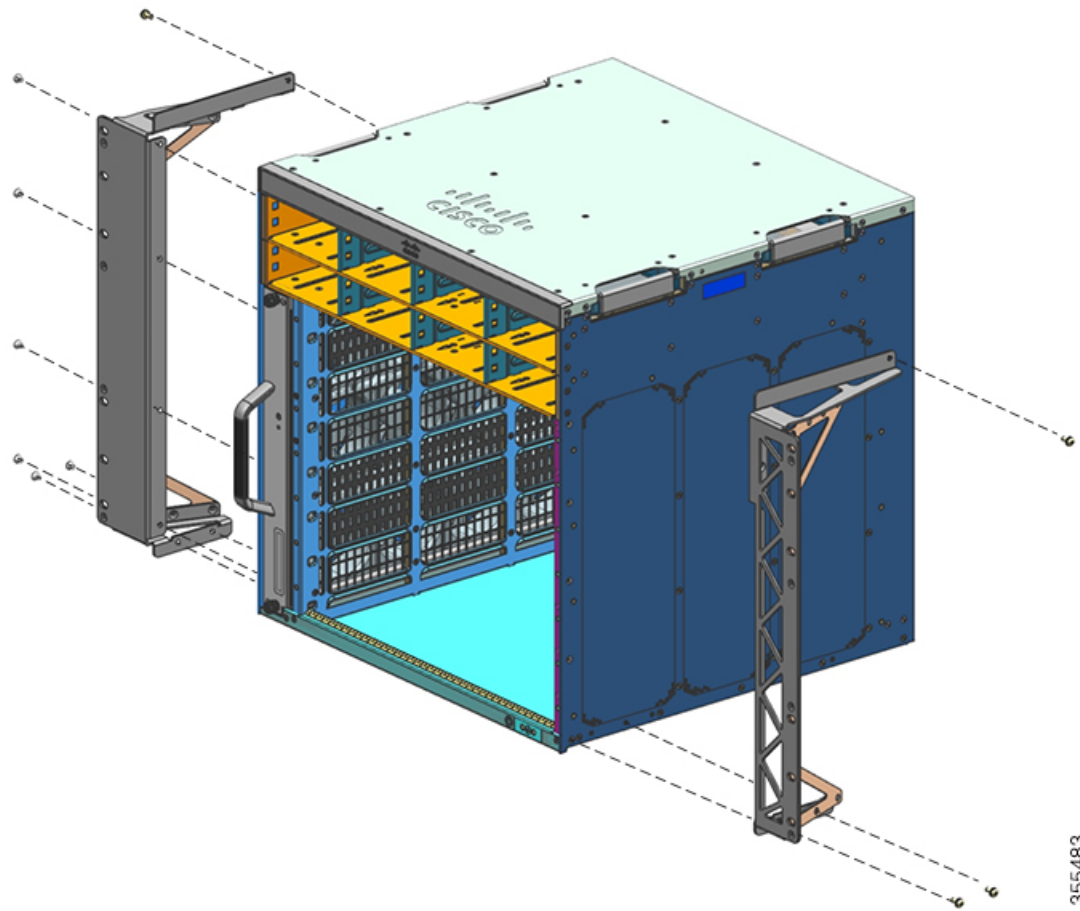

Step 3 Install the filter brackets.

Figure 23: Install the Filter Brackets

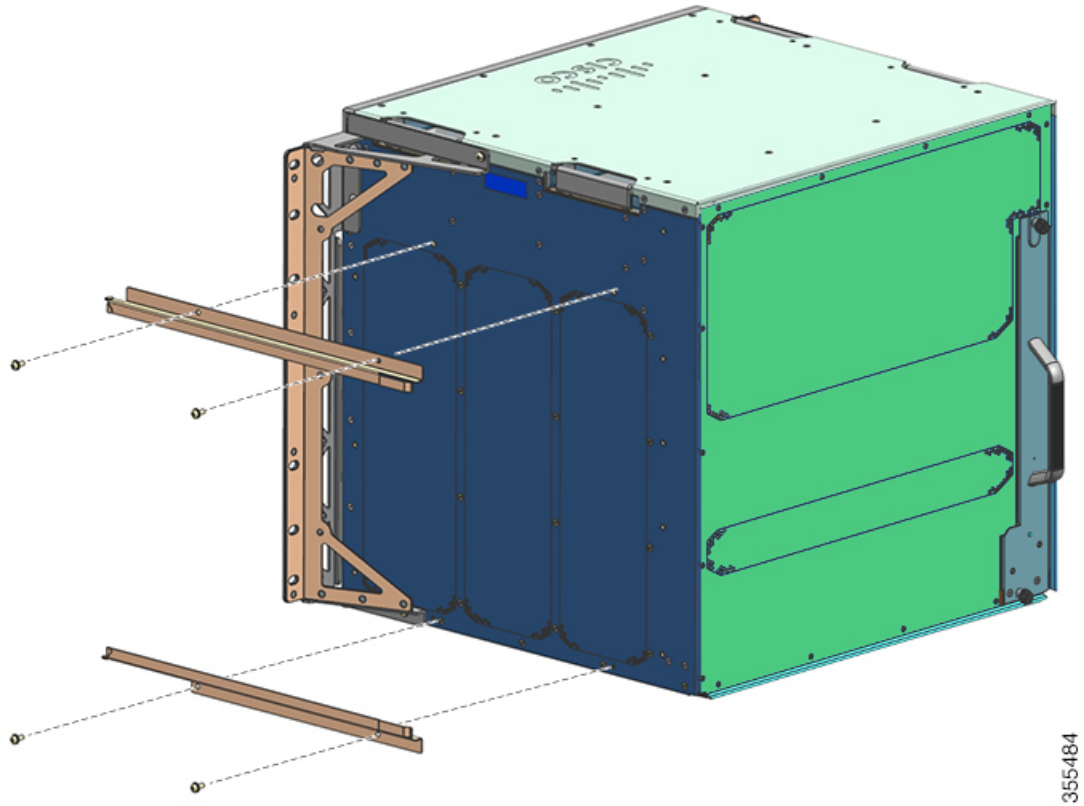

Step 4 Install the Right and Left Wall covers.

Figure 24: Install the Wall Covers

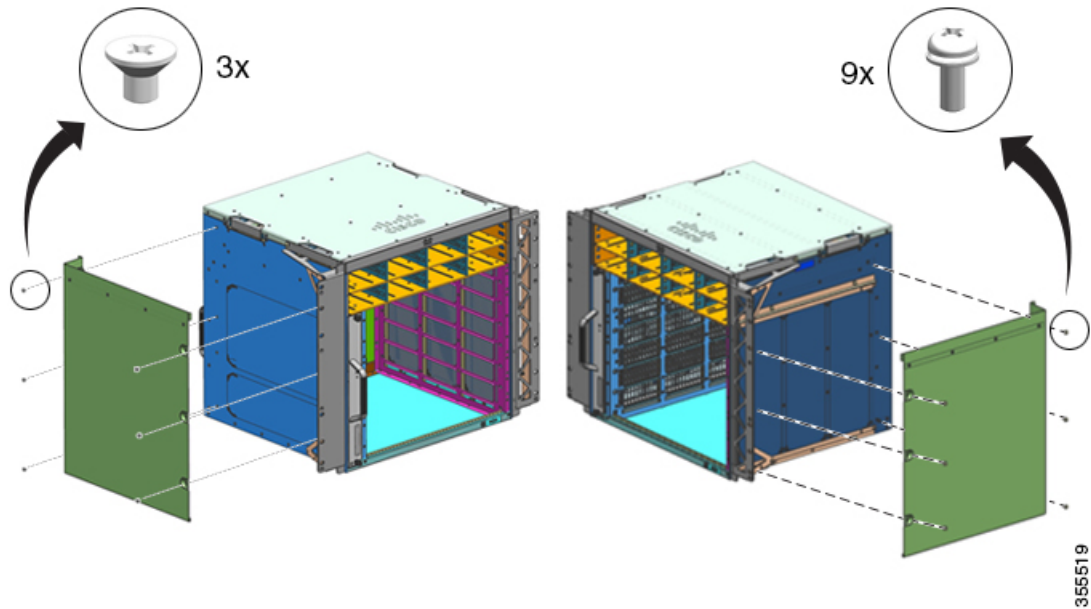
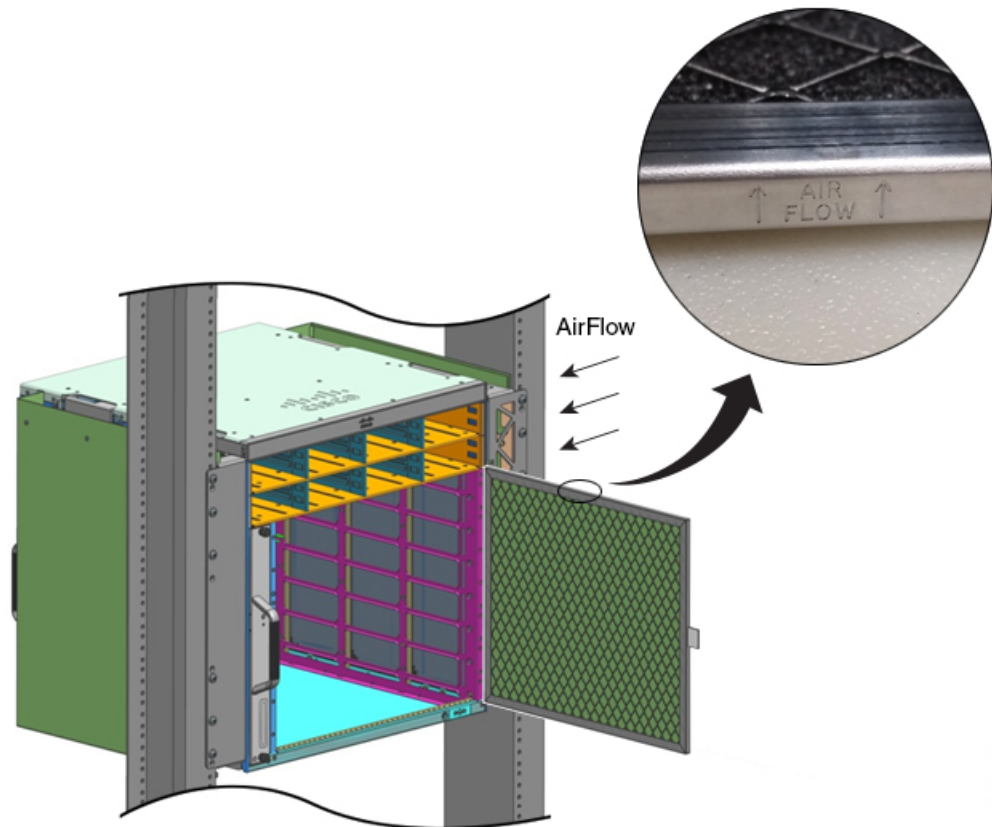

Figure 26: NEBS-Compliant Air Filter



Note We recommend that you change the air filter every 3 months. However, examine the air filter once a month (or more often in dusty environments) and replace it if it appears to be excessively dirty or damaged. To comply with Telecordia GR-63-Core standard air filter requirements for NEBS deployments, the air filter must be replaced, not cleaned.

Step 7 Install the top and base covers as shown in illustrations:

Figure 27: Top Cover and Base Cover

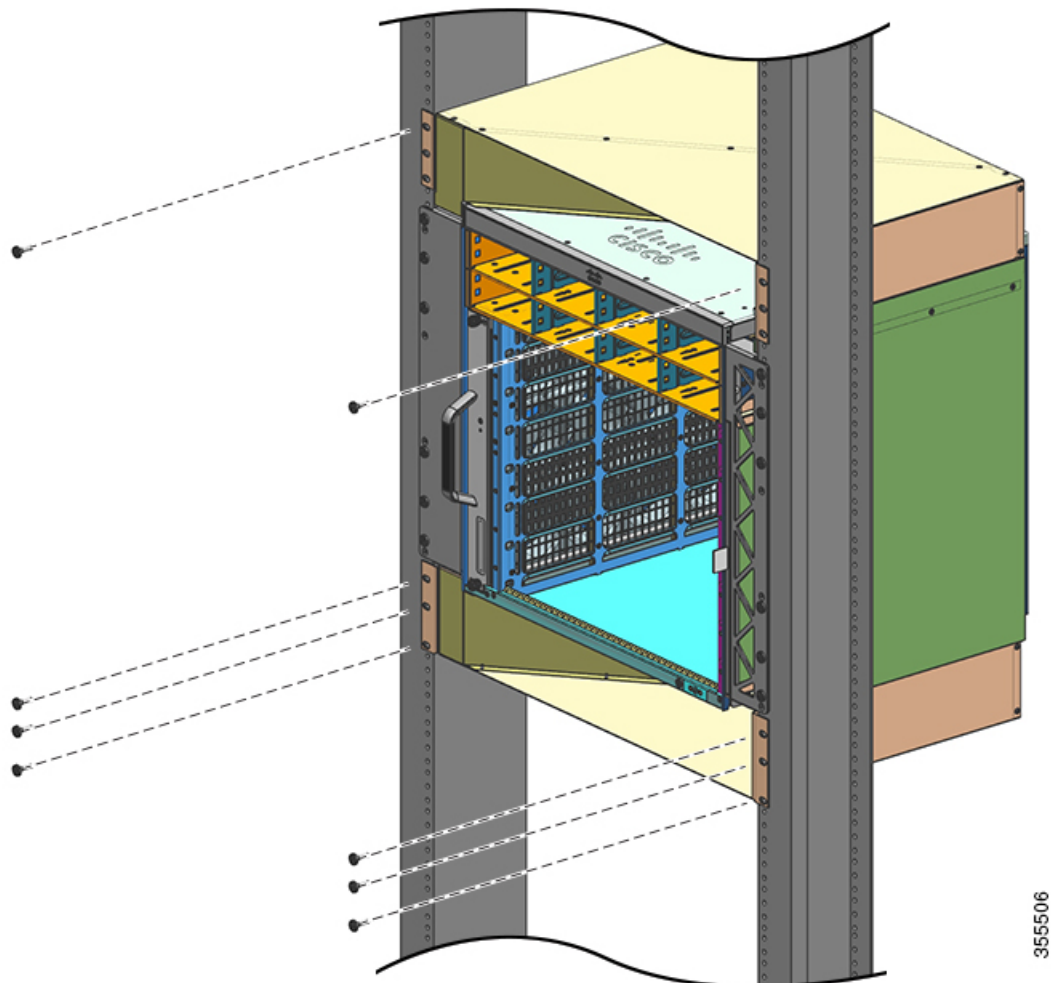

What to do next

After installing the chassis in a NEBS-Compliant mode, complete the installation process by:

1. Connecting the chassis to system ground.
2. Installing and connecting the power supplies to the power source.
3. Connecting the network interface cables to the supervisor module and line card modules. This may involve installing transceivers before you attach the network interface cables.
4. Powering up the chassis and verifying the installation.
5. Turning on the NEBS mode for the fan tray. See [Useful Cisco IOS Commands - Fan Tray Assembly](#), on page 139

Establishing System Ground

To attach the grounding lug and cable to the grounding pad, perform these steps:

Before you begin



Warning Statement 1003—DC Power Disconnection

To reduce risk of electric shock or personal injury, disconnect DC power before removing or replacing components or performing upgrades.



Warning Statement 1046—Installing or Replacing the Unit

To reduce risk of electric shock, when installing or replacing the unit, the ground connection must always be made first and disconnected last.

If your unit has modules, secure them with the provided screws.

To connect the system ground, you require the following tools and materials:

- Grounding lug—A two-hole grounding lug, which supports a 6 AWG size wire. Supplied as part of the standard accessory kit.
- Grounding screws—Two M4 x 8 mm (metric) pan-head screws. Supplied as part of the standard accessory kit.
- Grounding wire—The grounding wire should be sized according to local and national installation requirements. A 6 AWG copper conductor is required for U.S. installations. Commercially available 6 AWG wire is recommended. The length of the grounding wire depends on the proximity of the switch to proper grounding facilities.
- No. 1 Phillips screwdriver.
- Crimping tool to crimp the grounding wire to the grounding lug.
- Wire-stripping tool to remove the insulation from the grounding wire.

Procedure

- Step 1** Use a wire-stripping tool to remove approximately 0.75 inches (19 mm) of the covering from the end of the grounding wire.
- Step 2** Insert the stripped end of the grounding wire into the open end of the grounding lug.
- Step 3** Crimp the grounding wire in the barrel of the grounding lug. Verify that the ground wire is securely attached to the ground lug.
- Step 4** Secure the grounding lug to the system ground connector with two M4 screws. Ensure that the grounding lug and the grounding wire do not interfere with other switch hardware or rack equipment.

Figure 28: Locating and Connecting System Ground

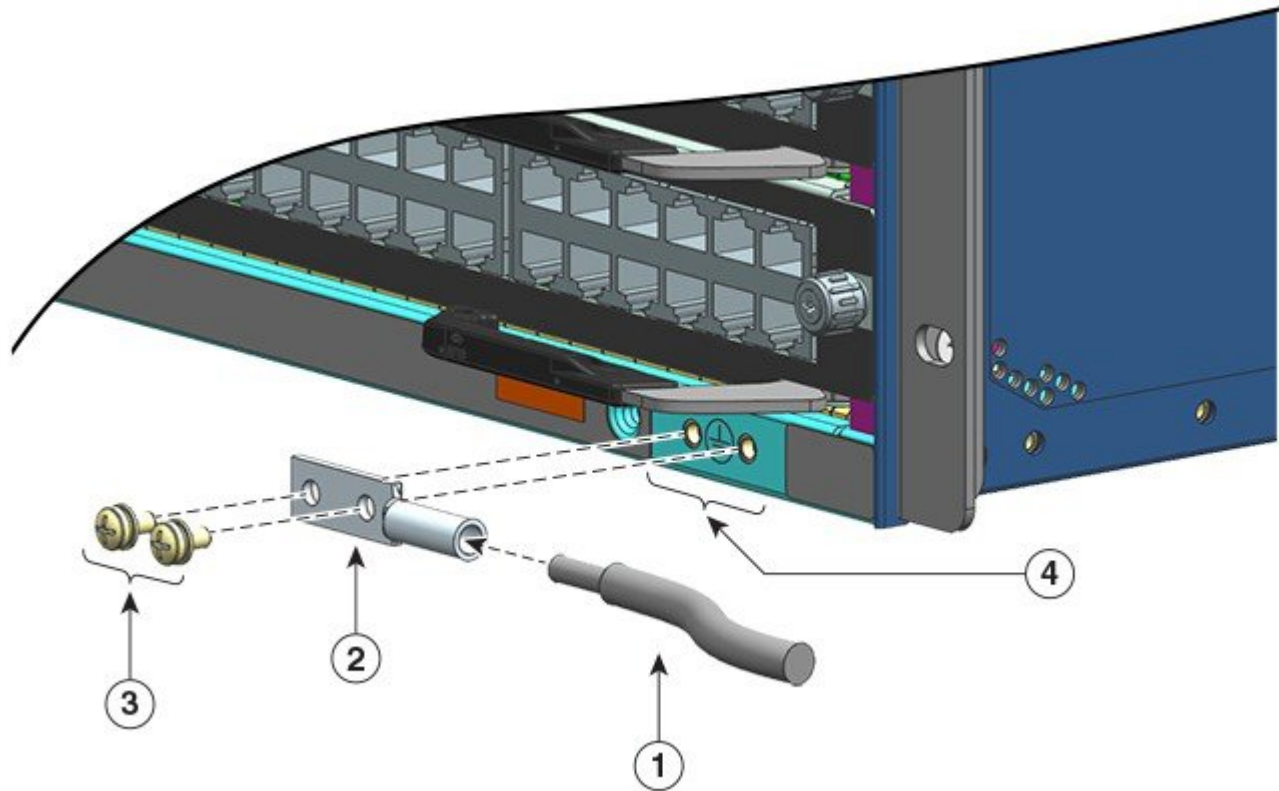

1	Stripped end of the grounding wire inserted into the open end of the grounding lug	3	M4 screws to secure the lug to the connector
2	Grounding lug	4	System ground location

Figure 29: System Ground Connected

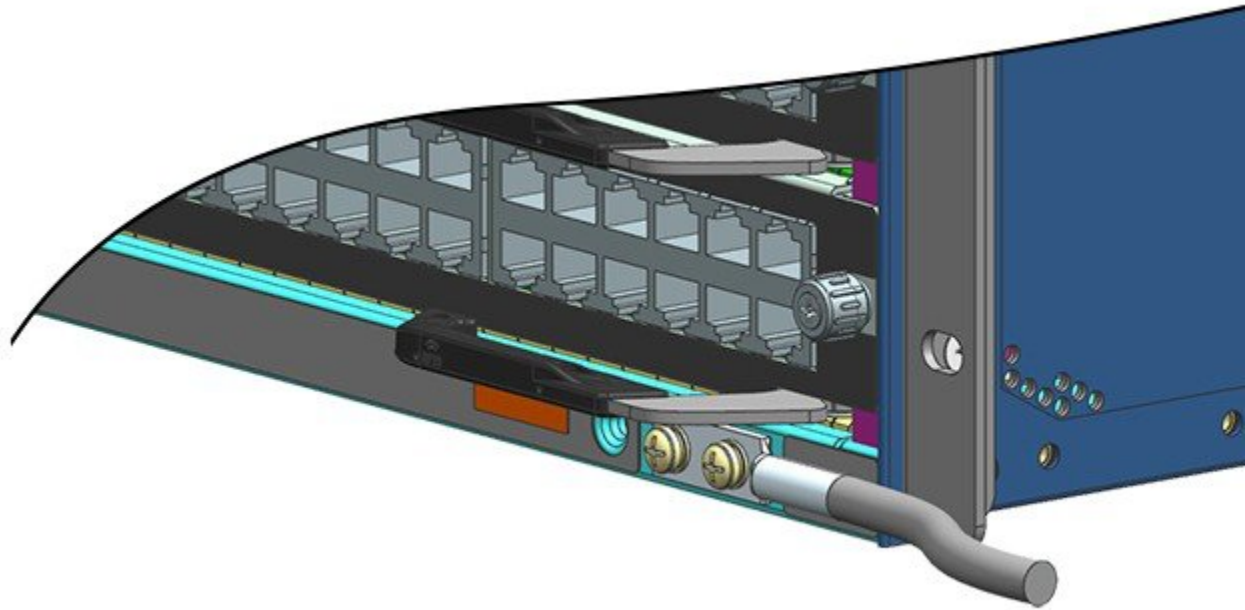

- Step 5** Prepare the other end of the grounding wire, and connect it to an appropriate grounding point in your site to ensure adequate earth ground for the switch.

Attaching an ESD Strap

After you install the system ground lug, follow these steps to correctly attach the electrostatic discharge (ESD) wrist strap that is provided with the standard accessory kit and all FRUs:

Before you begin

- Do not use the wrist strap if it is wet.
- Do not use the wrist strap on equipment with operating voltage exceeding 250V.
- Ensure that you are not grounded by any other means than through the wrist strap while servicing.

Procedure

- Step 1** Open the wrist strap package, unwrap and locate the two ends of the ESD strap.

One end of the strap terminates with the black metal strap exposed; this is wrist end. The other end terminates with a patch of copper foil; this is the equipment end.

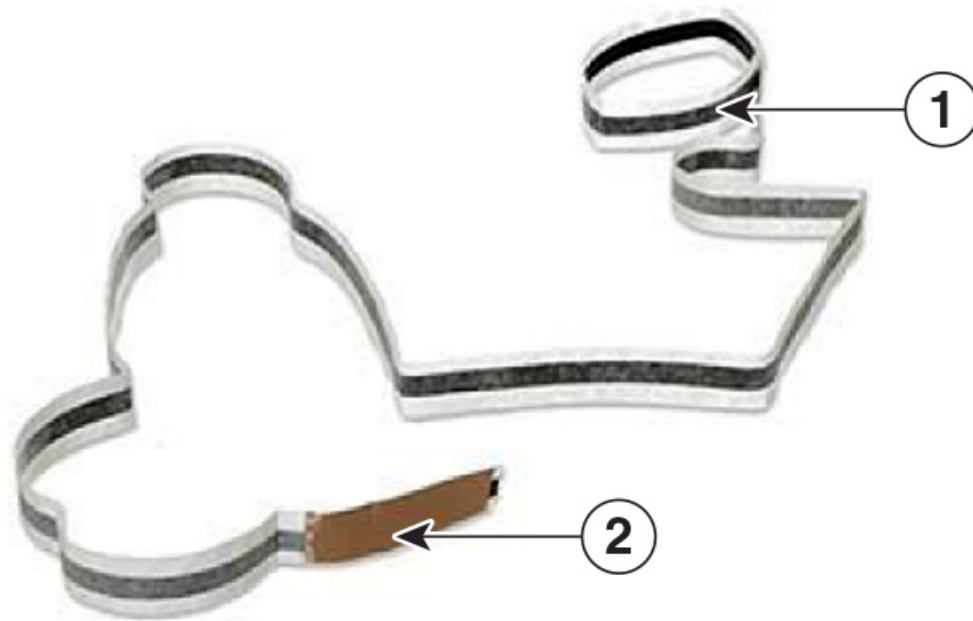

356215

1	Wrist end of the ESD wrist strap.	2	Equipment end of the ESD wrist strap
---	-----------------------------------	---	--------------------------------------

Step 2 On the wrist end of the strip, locate the length of conductive film. Wrap the adhesive side around your wrist such that it touches bare skin well.

Step 3 Peel off the adhesive from the equipment end and attach it to an unpainted metal surface of the equipment you are servicing.

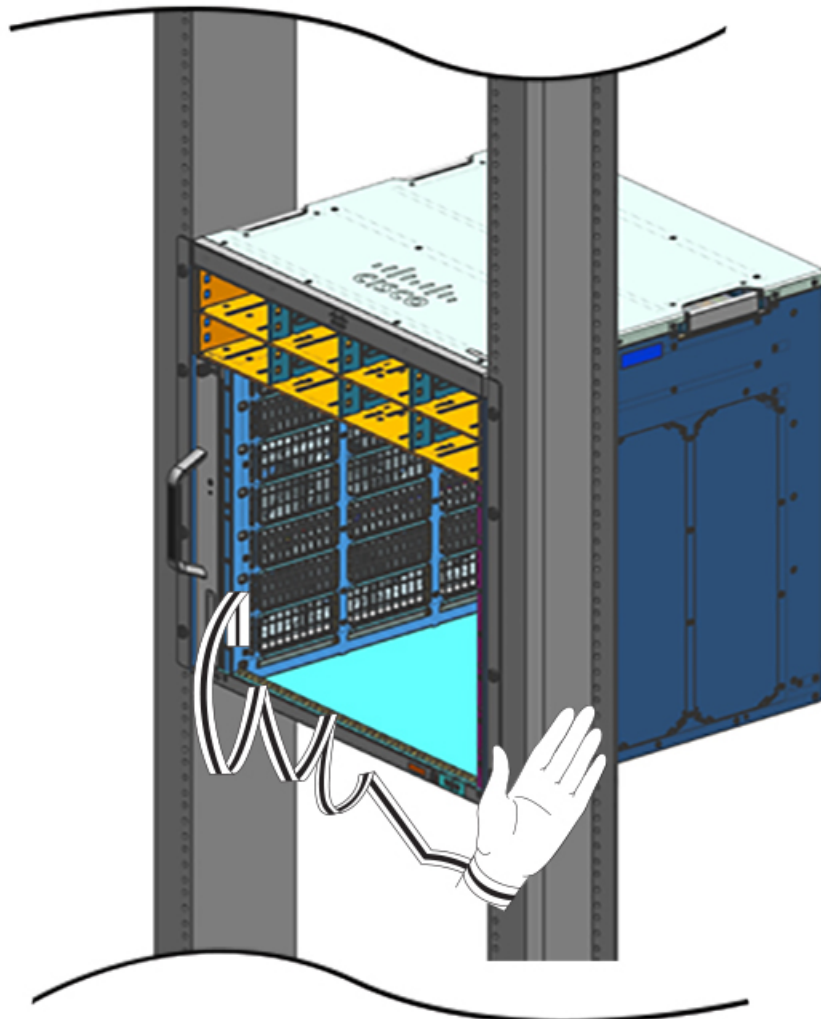

356216

When handling modules, follow these guidelines:

- Handle carriers using the available handles or edges only; avoid touching the printed circuit boards or connectors.
- Place a removed component boardside up on an antistatic surface or in a static shielding container. If you plan to return the component to the factory, immediately place it in a static shielding container.
- Never attempt to remove the printed circuit board from the metal carrier.

Caution For safety, periodically check the resistance value of the antistatic strap. The measurement should be between 1 and 10 megohm (Mohm).

Verifying the Switch Chassis Installation

To verify the switch chassis installation, perform these steps:

Procedure

- Step 1** Verify that the ejector levers of each module are fully closed (parallel to the faceplate) to ensure that the supervisor and all the line cards are fully seated in the backplane connectors.
- Step 2** Check the captive installation screws of each module, and tighten any loose captive installation screws.
- Step 3** Verify that all empty module slots and power supply bays have blanks installed properly. The blanks optimize the air flow through the chassis and contain EMI.

Warning **Statement 1029**—Blank Faceplates and Cover Panels

Blank faceplates and cover panels serve three important functions: they reduce the risk of electric shock and fire, they contain electromagnetic interference (EMI) that might disrupt other equipment, and they direct the flow of cooling air through the chassis. Do not operate the system unless all cards, faceplates, front covers, and rear covers are in place.

- Step 4** Turn on the power supply switches to power up the system. During the power-up sequence, the system performs a series of bootup diagnostic tests.

Note The switch is designed to boot up in less than 30 minutes, provided that the neighboring devices are in fully operational state.

What to do next

In case of a problem with any of the hardware components, refer to the [Troubleshooting, on page 131](#) section.

Additional system diagnostic tests are also available. These tests allow you to perform a complete sanity check on the system prior to inserting the system into your network and to monitor the health of the system while the system is running.



Tip When prestaging systems in a nonproduction environment, we recommend that you run all the diagnostic tests, including the disruptive tests, to prescreen the systems for failures, if any.



CHAPTER 6

Removing and Replacing FRUs

- [Removing and Installing a Fan Tray, on page 89](#)
- [Removing and Installing a Power Supply Module, on page 99](#)

Removing and Installing a Fan Tray

Online Insertion and Removal

While the fan tray is designed to be removed and installed while the system is operating (powered on) and without presenting an electrical hazard or damage to the system, there is a time constraint when you remove and replace the fan tray in a system that is powered on.



Caution If the service mode is *not* enabled, the system can safely run without a fan tray only for two minutes, until critical temperature threshold is exceeded. Watch for any alarms triggered in software. After the critical temperature threshold is exceeded, without sufficient cooling, the system shuts down if the alarm is not cleared.

When the fan tray is removed and replaced in a non operating system, there is no time constraint.

Following the Correct Removal and Replacement Procedure

When you order the fan tray or a spare, the entire fan tray assembly is shipped. The fan tray assembly consists of the fan tray and an adapter that is attached to the fan tray.

You can remove and replace the fan tray from the front or the rear. When removed from the front of the chassis, only the fan tray is removed. When removed from the rear, the entire fan tray assembly (including the adapter) is removed. Accordingly, you must detach the adapter from the spare fan tray assembly when installing or replacing the fan tray from the front; you must install the entire fan tray assembly when installing the spare from the rear.

Removal and replacement from the front is suited to situations where access to the rear of the system is restricted. For instance, where the installation is in a closet.

Removal and replacement from the rear is suited to situations where input and output cables are routed across the front panel, limiting access to the front panel of the fan tray.

Follow the corresponding removal and replacement procedures.

Enabling the Service Mode Before Removing a Fan Tray



Warning Statement 1073—No User-Serviceable Parts

There are no serviceable parts inside. To avoid risk of electric shock, do not open.

Enabling the service mode is a precautionary step that we recommend you complete, before you remove a fan tray from the chassis. In the service mode, the system pushes the fans to operate at full speed for 10 minutes, allowing the system to cool down sufficiently and sustain temperatures for the duration of servicing. The system automatically turns off (self-terminates) the service mode after 10 minutes.



Important Proceed with removing and replacing the fan tray immediately after the service mode self-terminates.

- If the service mode is *not* enabled before servicing, only *two* minutes of fan-less operation can be safely assured in a normal environment.
- If the service mode is enabled prior to servicing, *four* minutes of fan-less operation can be assured for all normal operating conditions, at full traffic load, in any configuration.

In a system that is operational, enabling the service mode applies to removal or replacement procedures from the front and the rear.

You do not have to enable this mode if you are removing and replacing the fan tray in a system that is not powered on. The service mode is also not required if the fan tray is being replaced for having two or more bad individual fans, because the fan tray will already be running at full speed.

To enable the service mode, enter the **test platform hardware chassis fantray service-mode on** command in the privileged EXEC mode. For example:

```
Device# test platform hardware chassis fantray service-mode on
fantray service mode on
```

To turn off the service mode before the system-allotted 10-minute duration, enter the **test platform hardware chassis fantray service-mode off** command in the privileged EXEC mode.

Removing a Fan Tray from the Front

When you remove a fan tray from the front, only the fan tray is removed, excluding the adapter. To remove a fan tray from the front, follow the steps described here.



Caution When removing the fan tray, keep your hands and fingers away from the spinning fan blades. Let the fan blades completely stop before you remove the fan tray.



Warning Statement 1073—No User-Serviceable Parts

There are no serviceable parts inside. To avoid risk of electric shock, do not open.



Warning **Statement 1074**—Comply with Local and National Electrical Codes

To reduce risk of electric shock or fire, installation of the equipment must comply with local and national electrical codes.

Before you begin

You may need a Phillips-head screwdriver to loosen the captive installation screws.

Procedure

Step 1 Ready the replacement fan tray.

Important When you remove and replace a fan tray in a system that is powered on, there is a time constraint. So it is important to complete this first step before you remove the fan tray from the front of the chassis.

- a) Remove the replacement fan tray from the shipping packaging.
- b) Use a Phillips-head screwdriver and loosen the two captive installation screws on the front panel of the replacement fan tray (the side with the fan STATUS LED), to detach it from the adapter module.

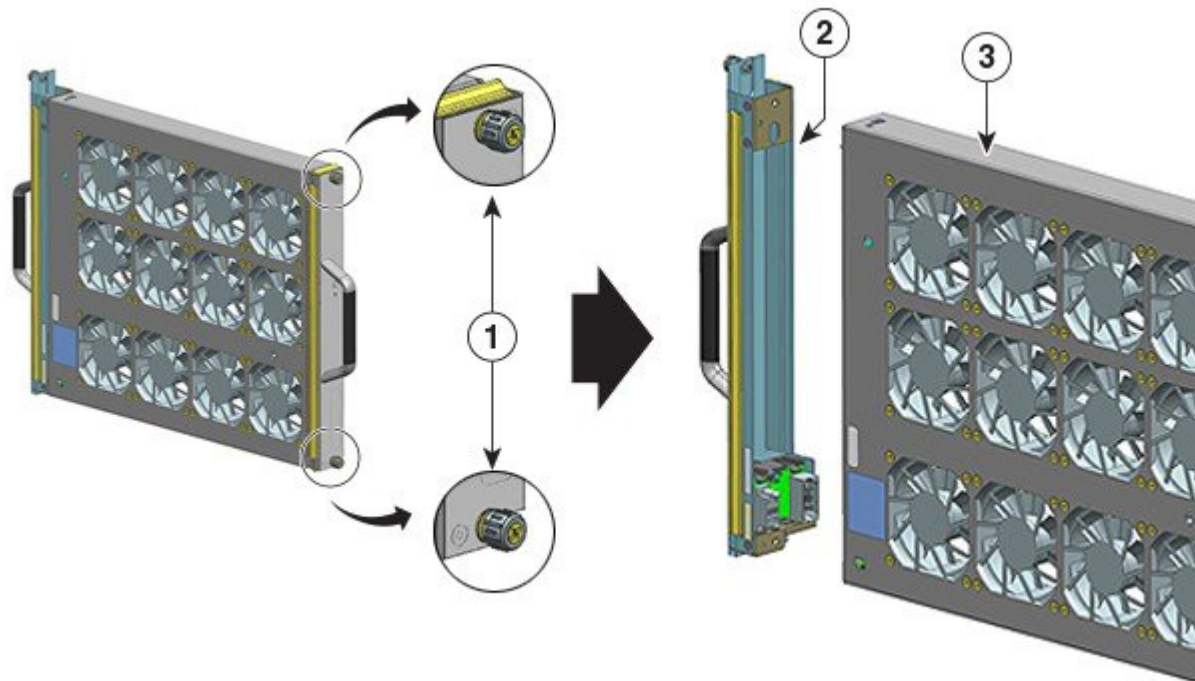

1	Captive installation screws on the front of the fan tray assembly that have to be loosened (the side with the fan STATUS LED)	3	Fan tray ready for installation from the front
2	The adapter, detached from the fan tray	-	-

The adapter module is not used or replaced when installed from the front. It can be scrapped or stored for future use.

c) Keep the replacement fan tray on an anti-static mat and within arm's reach.

Step 2 Enable the service mode

In a system that is powered on, enabling the service mode for the system-allotted 10 minutes safely assures fan-less operation for four minutes. See [Enabling the Service Mode Before Removing a Fan Tray, on page 90](#)

Important Proceed with removing and replacing the fan tray immediately after the service mode self-terminates.

Step 3 Remove the fan tray from the chassis - loosen the two captive installation screws on the front panel of the fan tray (the side with the fan STATUS LED).

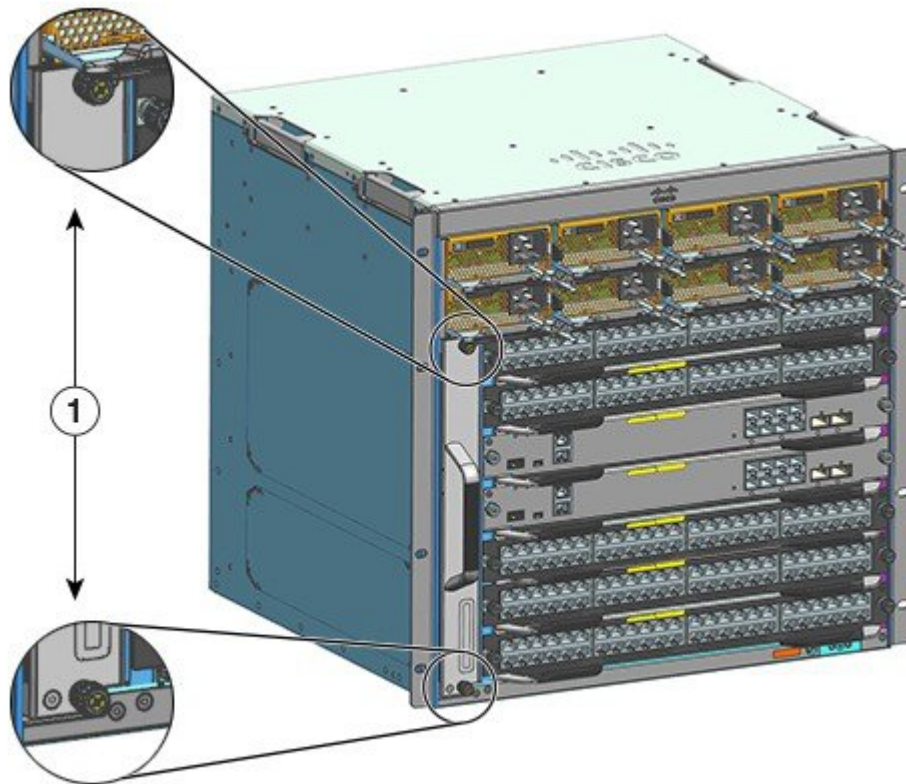

355294

1	Captive installation screws on the front panel of the fan tray in the chassis	-	-
---	---	---	---

- Step 4** Grasp the fan tray handle and pull it out only partially (0.25 inches), to unmate the connector and unseat it from the backplane. After unmatting the connector, allow three seconds to let the fan blades stop spinning completely.
- When unmatting the connector, gently move the fan tray from side to side, if necessary. The fans are equipped with a braking mechanism that fully stop the blades within three seconds of being de-energized (You will not be able to visually inspect the fan to see whether the blades are spinning or not).
- Step 5** Place your other hand underneath to support the bottom of the fan tray and then slide it out of the bay completely.
- Only the fan tray is removed from the chassis (excluding the adapter).

What to do next

Set the removed fan tray aside and immediately proceed with installing the replacement or spare fan tray.

Installing a Fan Tray from the Front

To install a fan tray from the front, follow the steps described here.



Warning Statement 1073—No User-Serviceable Parts

There are no serviceable parts inside. To avoid risk of electric shock, do not open.



Warning Statement 1074—Comply with Local and National Electrical Codes

To reduce risk of electric shock or fire, installation of the equipment must comply with local and national electrical codes.

Before you begin

Ensure that a replacement fan tray (with the adapter module detached), is ready for installation. There is a time constraint when you remove and replace a fan tray in a system that is powered on - if you have enabled the service mode prior to servicing, fan-less operation can be safely assured for four minutes only.

You may need a Phillips-head screwdriver to loosen the captive installation screws.

Procedure

-
- Step 1** Grasp the front handle with one hand and place your other hand underneath the fan tray to support it. Hold the fan tray with the fans facing to the right.
- Step 2** Place the fan tray in the fan tray bay such that it rests on the chassis, and then lift the fan tray up slightly, aligning the top and bottom guides.

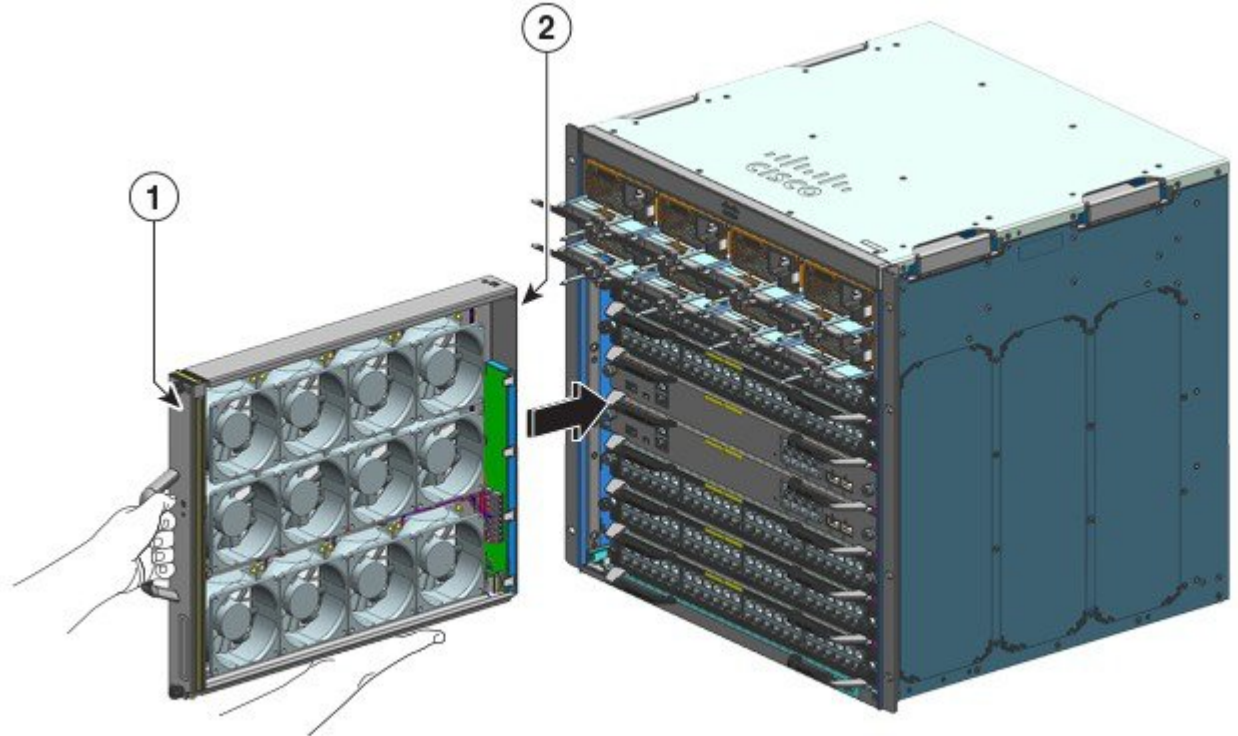

1	Front side of the fan tray	2	Fan tray without the adapter being installed from the front
---	----------------------------	---	---

- Step 3** Slide the fan tray into the chassis until the two captive installation screws make contact with the chassis.
- Step 4** Tighten the two captive installation screws on the front, to secure the fan tray assembly in the chassis.
- Step 5** Verify that you have installed the fan tray correctly. See [Verifying Fan Tray Installation, on page 98](#).

Removing a Fan Tray from the Rear

When you remove a fan tray from the rear, the fan tray assembly is removed. This includes the fan tray and the adapter. To remove a fan tray from the rear, follow the steps described here.



Caution When removing the fan tray, keep your hands and fingers away from the spinning fan blades. Let the fan blades completely stop before you remove the fan tray.



Warning **Statement 1073—No User-Serviceable Parts**
There are no serviceable parts inside. To avoid risk of electric shock, do not open.



Warning Statement 1074—Comply with Local and National Electrical Codes

To reduce risk of electric shock or fire, installation of the equipment must comply with local and national electrical codes.

Before you begin

You may need a Phillips-head screwdriver to loosen the captive installation screws.

Procedure

Step 1 Ready the replacement fan tray by removing it from the shipping packaging. Keep it on an anti-static mat and within arm's reach. Do not detach the adapter module.

Important When you remove and replace a fan tray in a system that is powered on, there is a time constraint. So it is important to complete this first step before you remove the fan tray from the rear of the chassis.

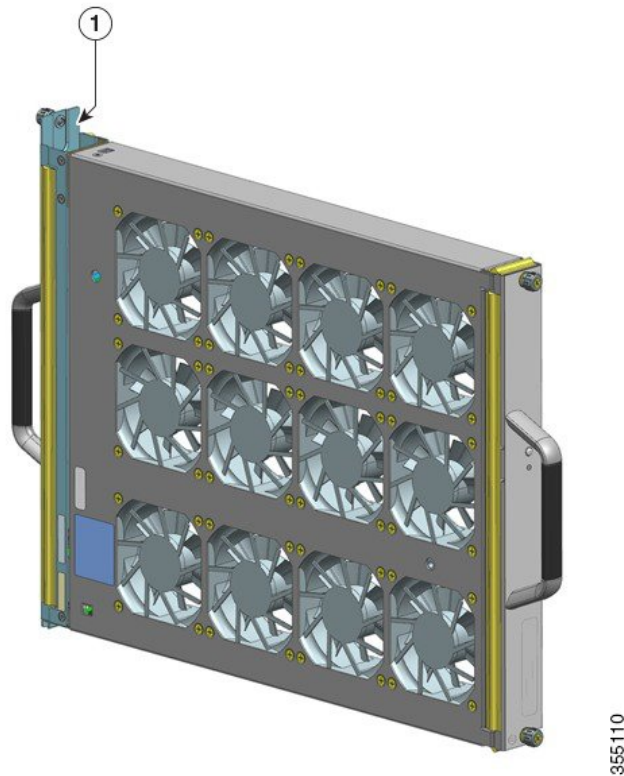

1	Fan tray assembly, with the adapter intact and ready for installation from the rear	-	-
---	---	---	---

Step 2 Enable the service mode

In a system that is powered on, enabling the service mode for the system-allotted 10 minutes safely assures fan-less operation for four minutes. See [Enabling the Service Mode Before Removing a Fan Tray](#), on page 90

Important Proceed with removing and replacing the fan tray immediately after the service mode self-terminates.

Step 3 Remove the fan tray from the chassis - loosen the two captive installation screws on the rear panel of the fan tray.

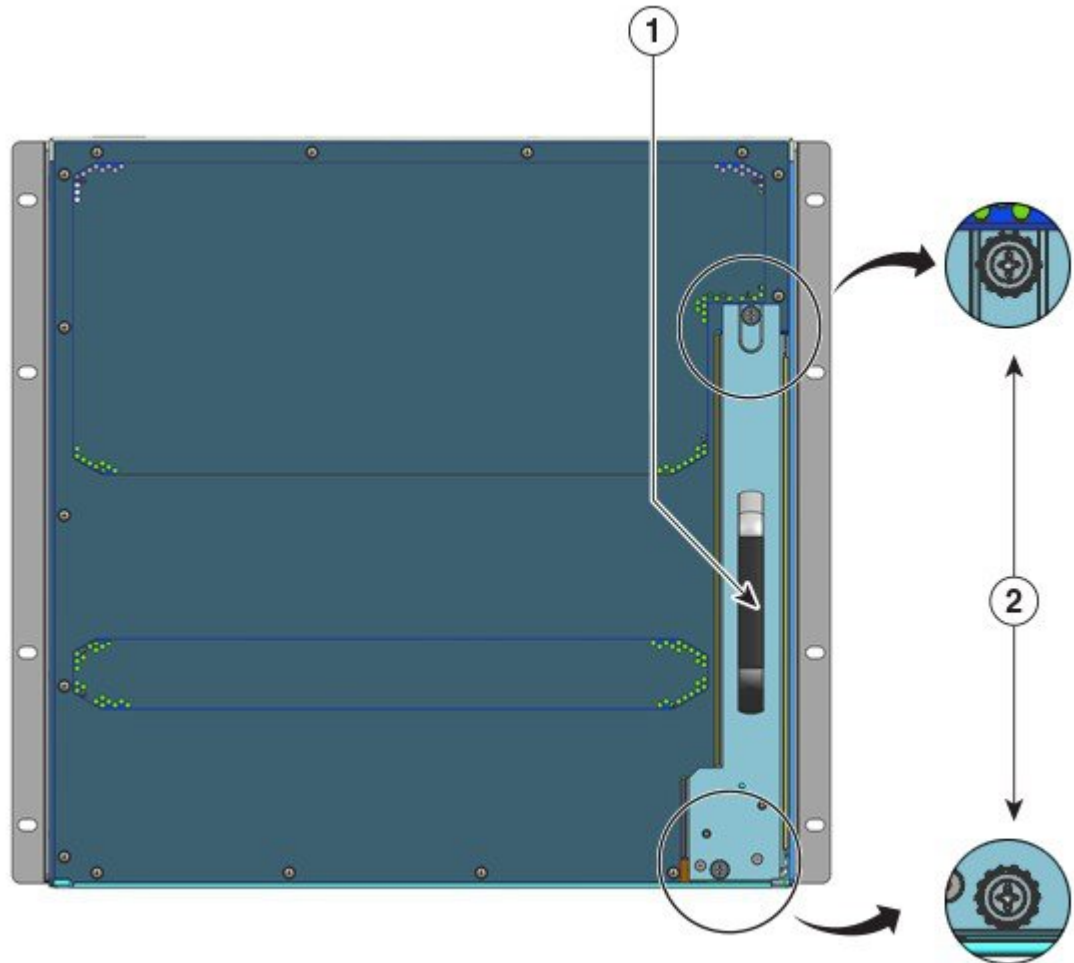

355110

1	Rear fan tray handle	2	Captive installation screws on the rear panel that have to be loosened to uninstall the fan tray assembly from the rear.
---	----------------------	---	--

Step 4 Grasp the fan tray handle and pull it out only partially (0.25 inches), to unmate the connector and unseat it from the backplane. After unmatting the connector, allow three seconds to let the fan blades stop spinning completely.

When unmating the connector, gently move the fan tray from side to side, if necessary. The fans are equipped with a braking mechanism that fully stop the blades within three seconds of being de-energized (You will not be able to visually inspect the fan to see whether the blades are spinning or not).

Step 5 Place your other hand underneath to support the bottom of the fan tray and then slide it out of the bay completely.

The entire fan tray assembly is removed from the chassis (including the adapter).

What to do next

Set the removed fan tray aside and immediately proceed with installing the replacement or spare fan tray.

Installing a Fan Tray from the Rear

To install a fan tray from the rear, follow the steps described here.



Warning **Statement 1073**—No User-Serviceable Parts

There are no serviceable parts inside. To avoid risk of electric shock, do not open.



Warning **Statement 1074**—Comply with Local and National Electrical Codes

To reduce risk of electric shock or fire, installation of the equipment must comply with local and national electrical codes.

Before you begin

Ensure that a replacement fan tray assembly (with the adapter module intact), is ready for installation. There is a time constraint when you remove and replace the fan tray in a system that is powered on - if you have enabled the service mode prior to servicing, fan-less operation can be safely assured for four minutes only.

You may need a Phillips-head screwdriver to loosen the captive installation screws.

Procedure

Step 1 On the replacement fan tray assembly, ensure that the two screws securing the fantray to the adapter (on the side with the fan STATUS LEDs) are tight. Be careful not to overtighten the screws.

Step 2 Grasp the rear handle with one hand and place your other hand underneath, to support the bottom of the fan tray assembly (such that the side with the STATUS LED is inserted first).

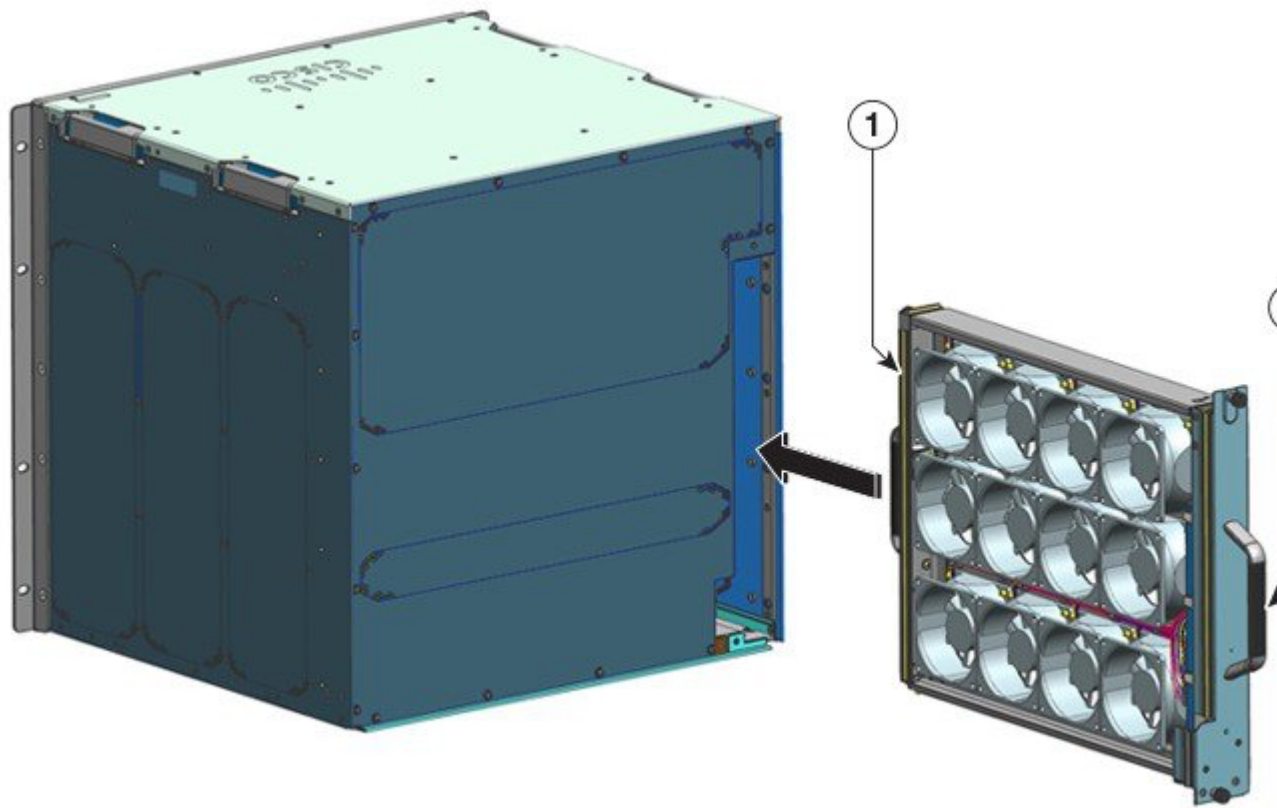

1	Front of the fan tray. Tighten the captive installation screws on this side <i>before</i> sliding the fan tray in.	2	Rear panel of the fan tray. Tighten the captive installation screws on this side, <i>after</i> sliding the fan tray in.
---	--	---	---

- Step 3** Place the fan tray assembly into the fan tray bay so it rests on the chassis. Lift the fan tray up slightly, aligning the top and bottom guides.
- Step 4** Slide the fan tray assembly into the chassis until the two captive installation screws make contact with the chassis.
- Step 5** Tighten the two captive installation screws on the rear to secure the fan tray assembly in the chassis.
- Step 6** Verify that you have installed the fan tray correctly. See [Verifying Fan Tray Installation, on page 98](#)

Verifying Fan Tray Installation

To verify that the new fan tray is installed correctly and is operating properly, follow these steps:

Before you begin

To check the operation of the fans, you should have powered up the chassis.

Procedure

Step 1 Listen for the fans; you should immediately hear them operating. If you do not hear them, ensure

- a) That the fan tray is inserted completely in the chassis
- b) That the faceplate is flush with the chassis panel.
- c) That the captive installation screws have been tightened sufficiently.

Important If the fan tray is not installed correctly, the fans may not run at all, or they may run at full speed. When the fan tray operates at full speed, increased noise levels may be expected.

Step 2 Check if the fan tray LED is lit and is green.

If the LEDs indicate a problem, see the [Troubleshooting the Fan Tray Assembly, on page 137](#) section for help with isolating the problem.

What to do next

If after several attempts the fans do not operate, or if you experience trouble with the installation (for instance, if the captive installation screws do not align with the chassis holes), contact Cisco Technical Assistance Center (see [Cisco Support](#)), for assistance.

Removing and Installing a Power Supply Module

Cisco Catalyst 9400 Series chassis supports field-replaceable AC-input and DC-input power supply modules. This section describes how to remove and install both kinds of modules.

If you install modules of different types (AC input and DC input) and capacities, ensure that you have taken [Power Supply Module Installation Considerations](#) into account, and that all required conditions are met.

Power supply modules are hot-swappable

- In a redundant mode, you do not have to power down the switch to replace or upgrade the power supplies.
- In the combined mode, the module is still hot-swappable as long as the difference between total output power and the total used power is greater than the capacity of the module being removed.

Total output power – Total used > Capacity of power supply module being removed.



Warning Statement 1005—Circuit Breaker

This product relies on the building's installation for short-circuit (overcurrent) protection. Ensure that the protective device is rated not greater than these values for US and EU:

- 20A circuit breakers for AC-input power supply.
 - 50A DC-rated circuit breakers for each input for safety purposes - irrespective of whether the inputs are power from a single or separate DC sources.
-



Warning **Statement 1022**—Disconnect Device

To reduce the risk of electric shock and fire, a readily accessible disconnect device must be incorporated in the fixed wiring.



Warning **Statement 1073**—No User-Serviceable Parts

There are no serviceable parts inside. To avoid risk of electric shock, do not open.



Warning **Statement 1086**—Replace Cover on Power Terminals

Hazardous voltage or energy may be present on power terminals. To reduce the risk of electric shock, make sure the power terminal cover is in place when the power terminal is not being serviced. Be sure uninsulated conductors are not accessible when the cover is in place.



Warning **Statement 9001**—Product Disposal

Ultimate disposal of this product should be handled according to all national laws and regulations.

Removing and Installing an AC-Input Power Supply Module

This section describes how to remove and install an AC-input power supply module.

Before you begin, read [Power Connection Guidelines for AC-Powered Systems, on page 38](#)

Removing an AC-Input Power Supply Module

To remove an AC-input power supply module, follow the steps described here.

Before you begin



Warning **Statement 1073**—No User-Serviceable Parts

There are no serviceable parts inside. To avoid risk of electric shock, do not open.

Procedure

-
- Step 1** Set the AC-input power supply rocker switch to the OFF (0) position

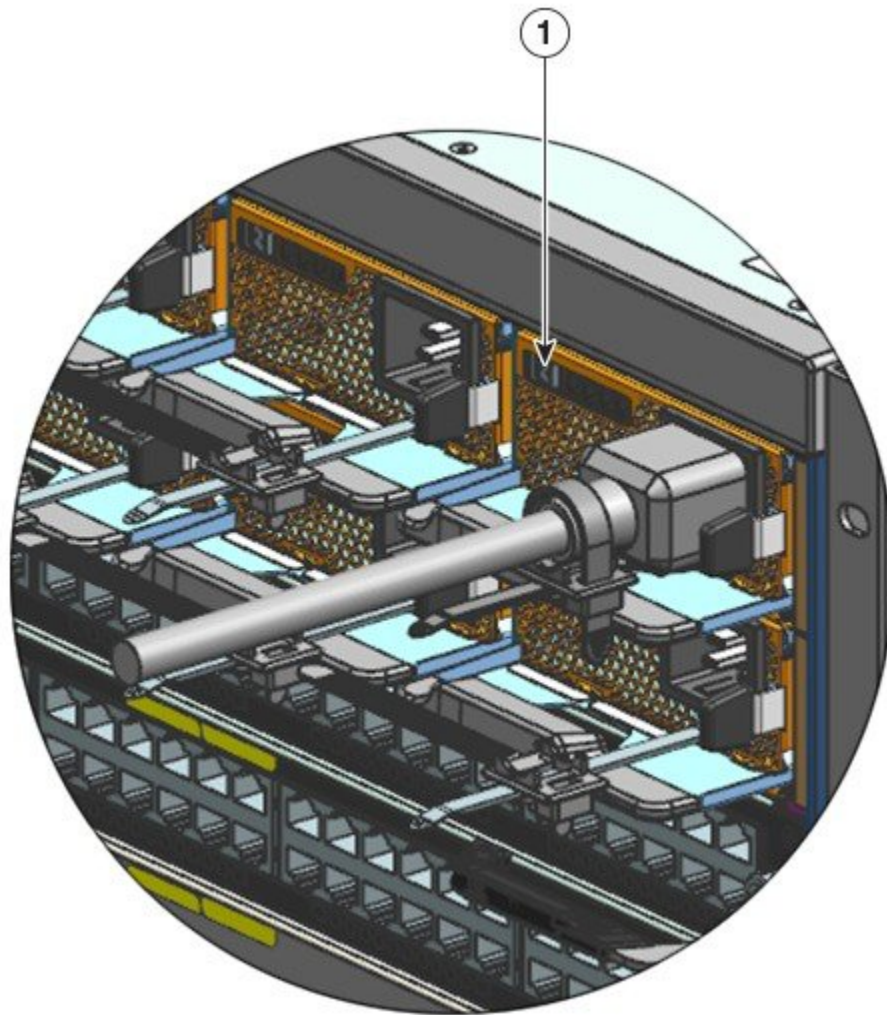

355184

1	Power supply in the OFF (0) position	-	-
---	--------------------------------------	---	---

Step 2 Loosen and remove the retainer strip that is around the power cord.

See [Power Cord Retainer Mechanism, on page 107](#)

Step 3 Remove the power cord from AC-in receptacle.

Step 4 Press the release latch of the power supply module inward.

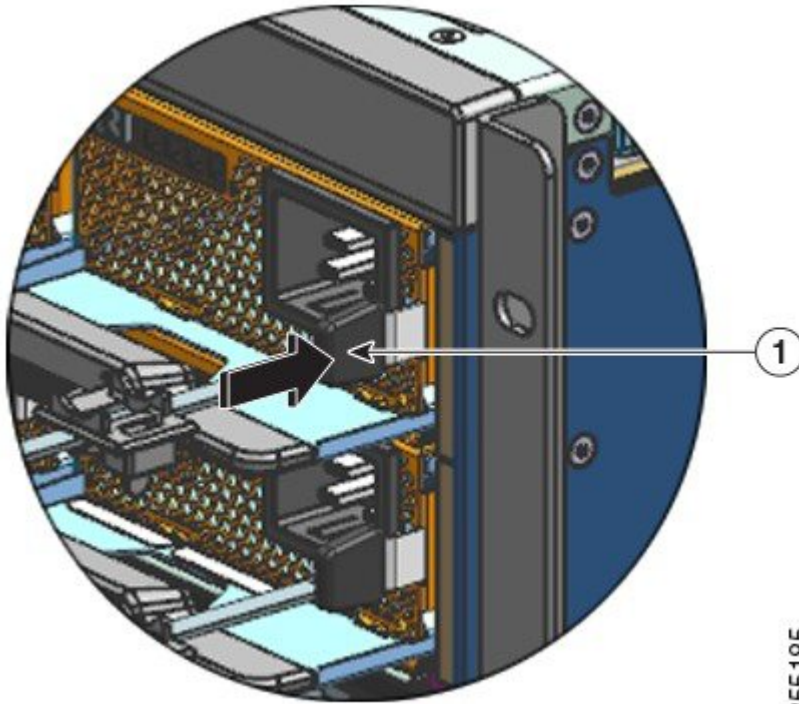

355185

1	Release latch, which should be pressed inwards	-	-
---	--	---	---

Step 5 Grasp the power supply module with one hand; place your other hand underneath to support the bottom of the power supply. Slide it out of the bay completely.

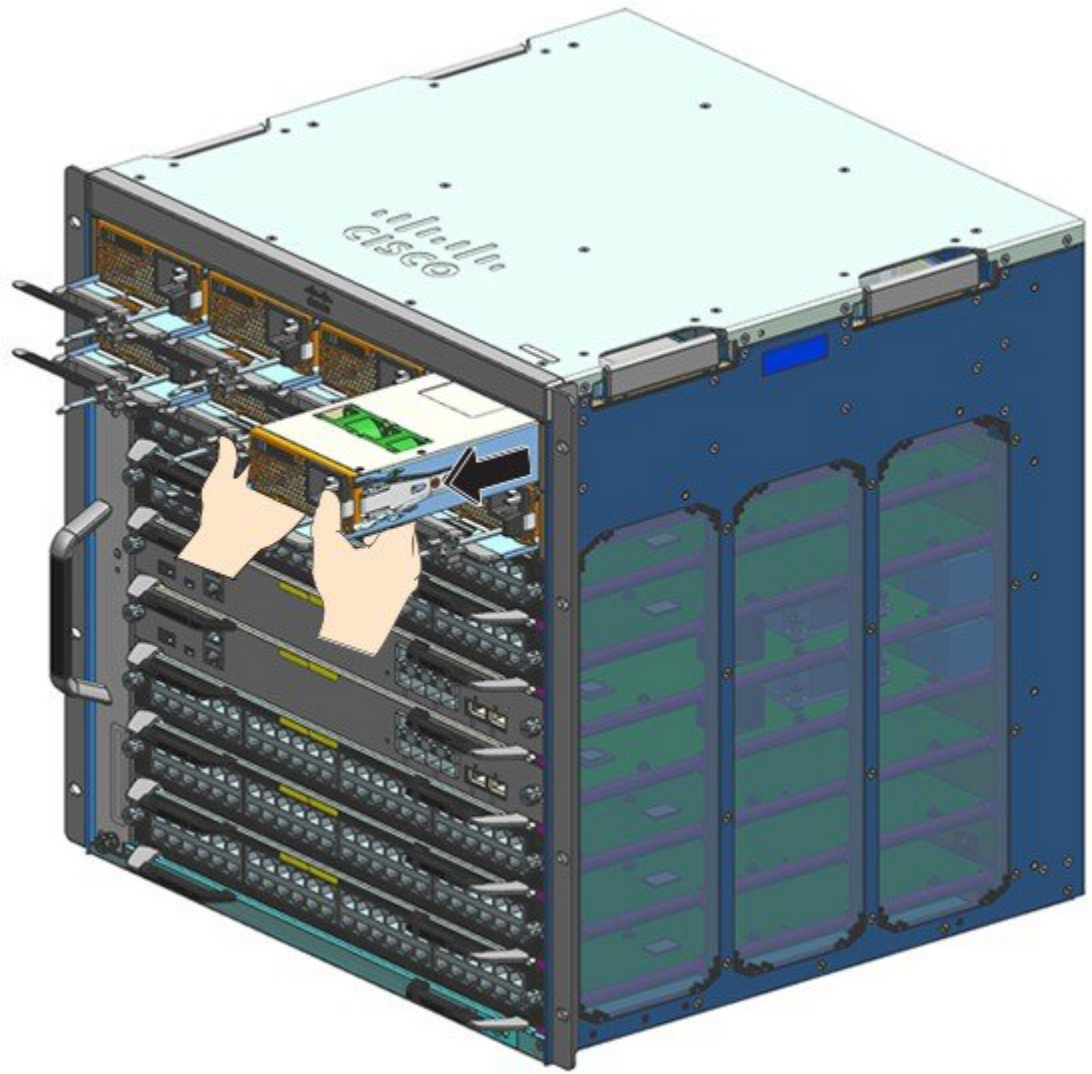

355186

Caution Do not leave any power supply slot open for any amount of time while the system is powered up. Prior to inserting a new power supply unit, for instance, when replacing the unit, ensure there are no foreign, conductive or other objects, or debris in the slot.

Warning **Statement 1028—More Than One Power Supply**

This unit might have more than one power supply connection. To reduce risk of electric shock, remove all connections to de-energize the unit.

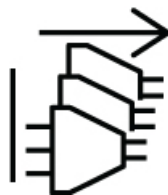

In the course of its operation the system may require more than one power supply installed and supplying power. Should it become necessary to remove an active power supply unit from the system, consult the user manual for proper system administration of available power. In order to safely de-energize the power supply unit, the input power should first be turned off by activating the rocker input power switch into the OFF state and the power cable physically disconnected from the unit. The unit must then be removed from the slot and stowed safely away in a proper antistatic bag. Care must be taken not to touch any of the exposed pins from the backplane connector. When a replacement power supply unit is to be installed, its rocker switch must always be in the OFF state and no input power cable be installed prior to inserting it into the slot. After the unit is seated, the input power cable may then be installed and fastened securely before activating the input power into the ON state with the rocker input power switch prior to energizing the unit.

What to do next

Set the power supply aside and proceed with installing the new or replacement power supply module. Install blank covers in all power supply bays that are to remain empty (C9400-PWR-BLANK). For information about installing blank covers, see [Removing and Installing a Power Supply Blank, on page 127](#)

Installing an AC-Input Power Supply Module

To install an AC-input power supply module, follow the steps described here.

Before you begin



Warning Statement 1073—No User-Serviceable Parts

There are no serviceable parts inside. To avoid risk of electric shock, do not open.

Ensure that you have installed the cable guide before you begin the procedure. This is to properly guide and arrange the power cords that you will attach as part of the installation. Since there are two rows of power supply bays, the cable guide ensures that the power cords from one row of power supplies do not interfere with the removal or replacement of modules in another row.

Procedure

- Step 1** Remove the replacement power supply from its shipping packaging.
- Step 2** Verify that the replacement power supply power switch is in the off (0) position.
- Step 3** If installed, remove the blank power supply cover from the empty power supply bay. For information about removing blank covers, see [Removing and Installing a Power Supply Blank, on page 127](#). Save the blank cover for future use.
- Step 4** Grasp the power supply handle with one hand and place your other hand underneath to support the bottom of the power supply. Slide the power supply all the way into the power supply bay. Make sure that the power supply is fully seated in the bay.

When correctly installed, the latch on the power supply locks-in the module, to avoid accidental removal of the module.

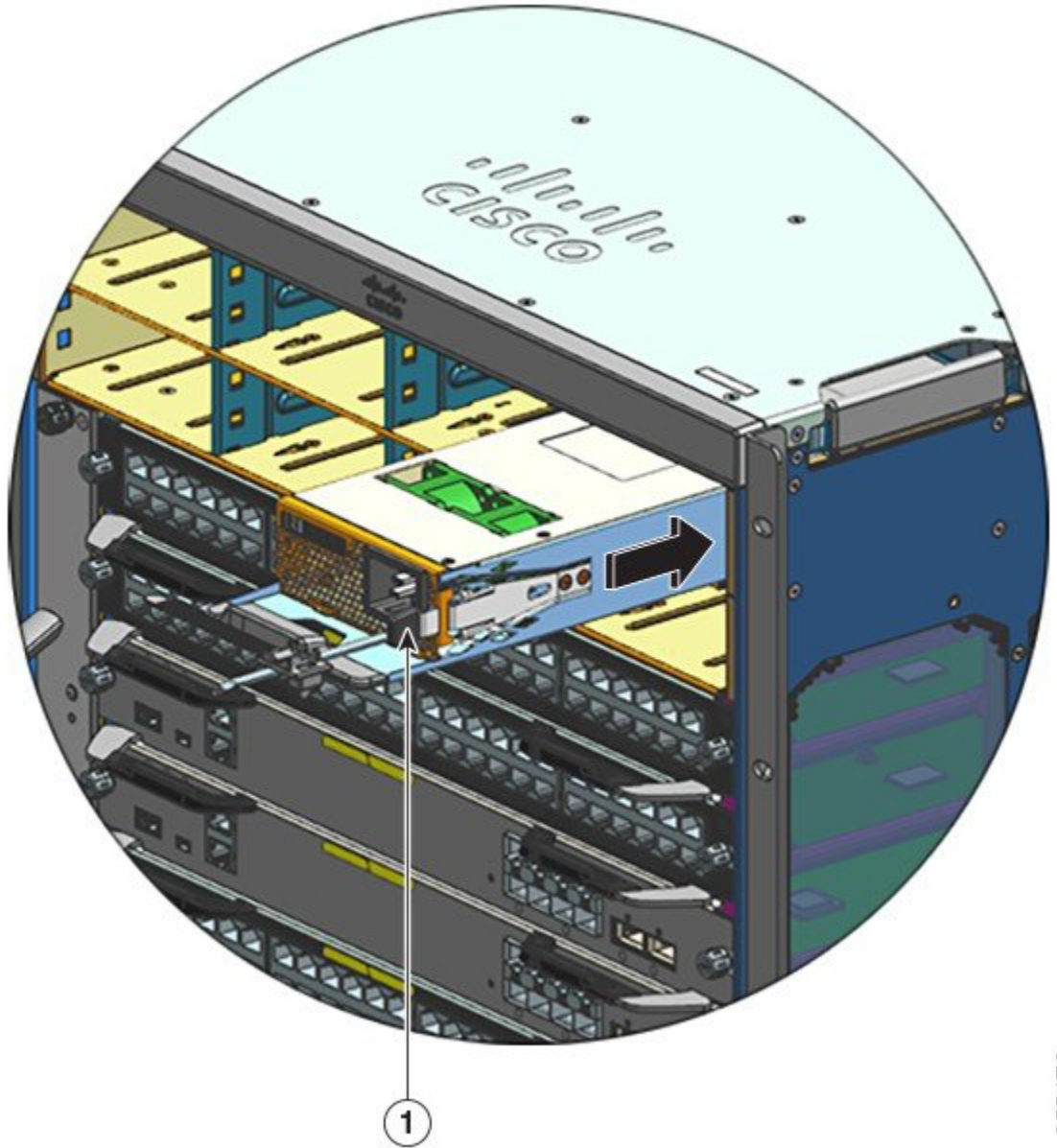

355179

1	Power supply latch, which clicks into place.	-	-
---	--	---	---

Step 5 Verify that all site power and grounding requirements have been met.

Step 6 Verify that you have the correct AC power cord for your location and power supply rating and only then plug the power cord connector into the power supply AC-in receptacle.

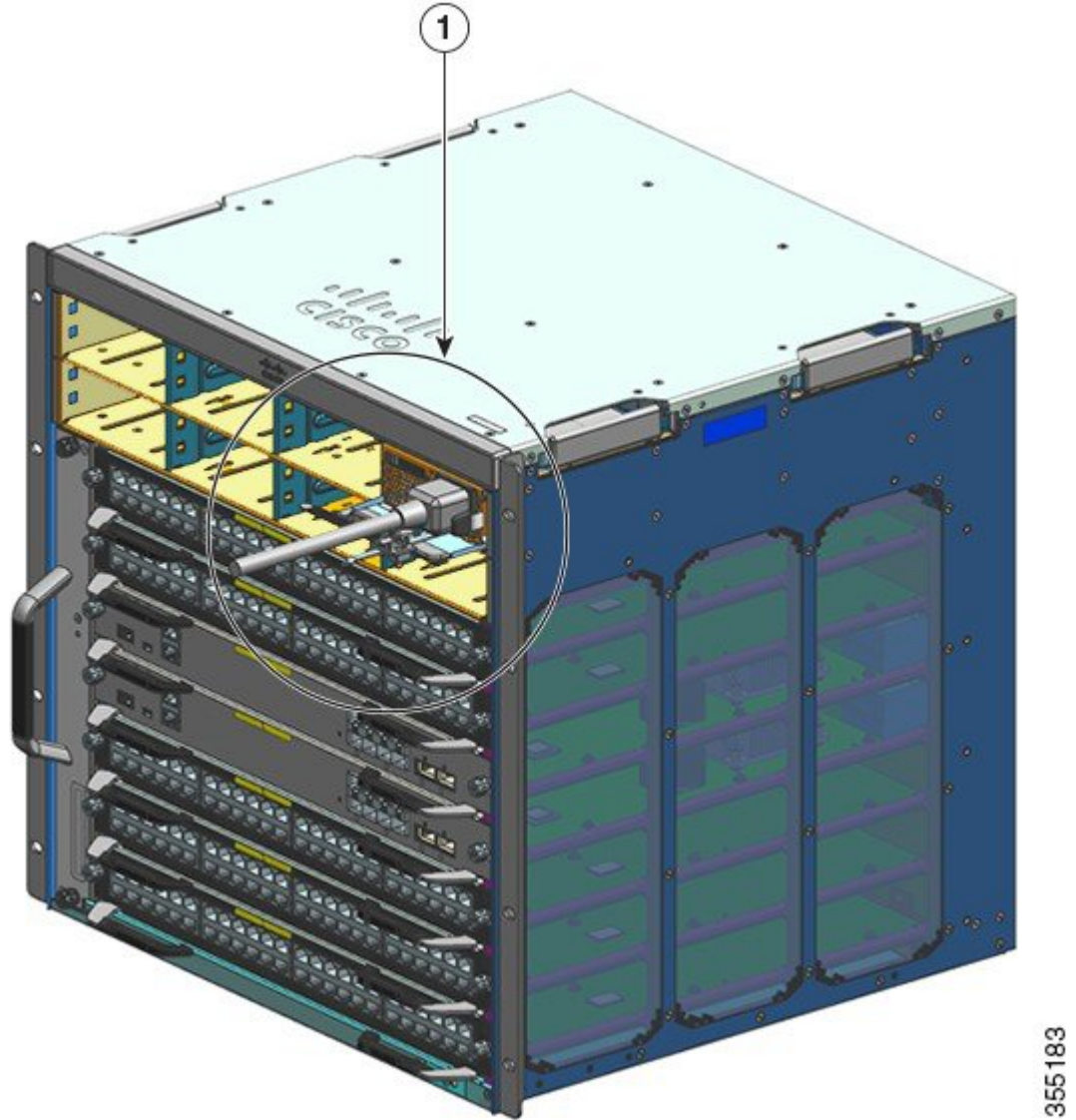

355183

1	Power cord, plugged into the AC-in receptacle.	-	-
---	--	---	---

Step 7 Strap in the power cord retainer, to hold it in place and avoid accidental removal.
See [Power Cord Retainer Mechanism](#), on page 107

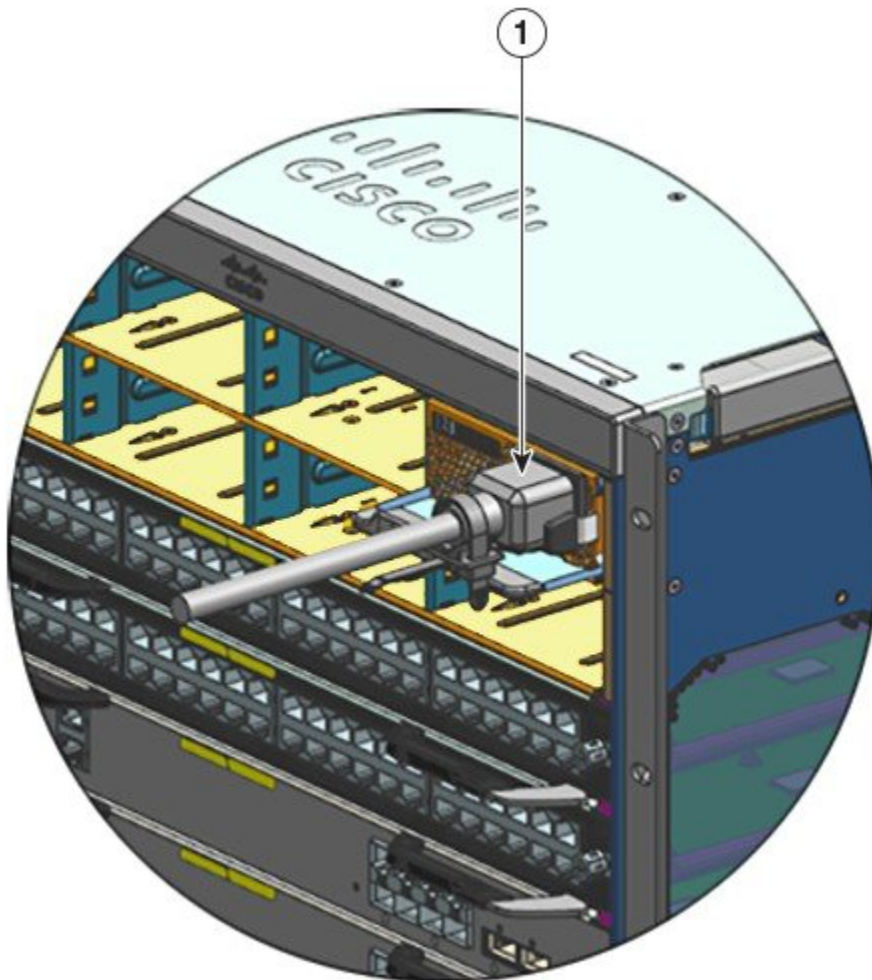

355181

1	Power supply fully inserted into the chassis; power cord and retainer strapped into place.	-	-
---	--	---	---

Step 8 Set the power switch to the on (I) position.

Step 9 Verify the module's operation by performing the steps described here: [Verifying the Power Supply Module Installation, on page 129](#).

Power Cord Retainer Mechanism

This section shows how to correctly operate the power cord retainer, to tighten or loosen it while installing or removing the power supply module.



Note Some of the illustrations do not include the power supply module, for the sake of clarity. The retainer is otherwise permanently fixed to the power supply module.

Figure 30: Parts of the Power Cord Retainer

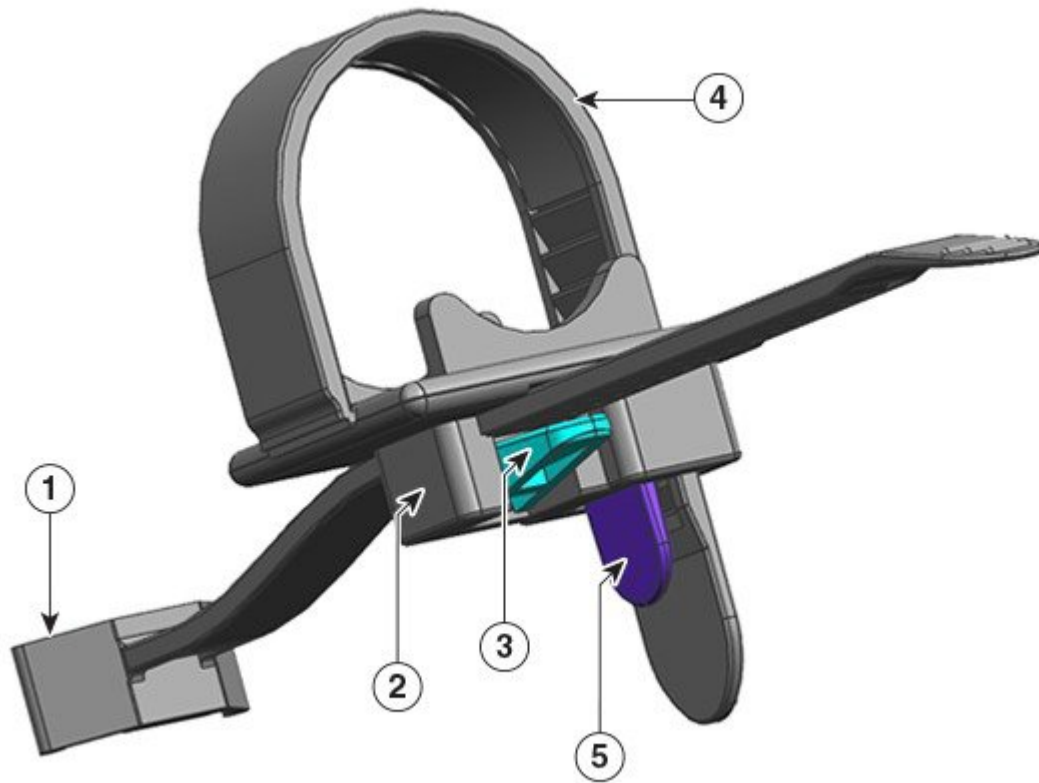

355187

1	The end that is fixed to the power supply module	4	Flexible retainer strip
2	Clamp which can move towards the power supply or away from it	5	Retainer strip latch
3	Clamp latch	-	-

Installation and Removal Sequence

Installation—After you have inserted the power supply module into the bay, first position the clamp closest to the power supply, near the plug round cylinder stress relief and then insert the flexible retainer strip into the clamp hole and tighten. The clamp cannot be moved after the flexible retainer strip is inserted into the clamp hole.

Removal—After you have turned off the power supply module's rocker switch, first remove the flexible retainer strip from the clamp hole and then adjust the position of the clamp to remove the power cord.

Positioning the Clamp

In [Figure 31: Positioning the Clamp](#), the clamp can always move freely in direction 3a.

To move the clamp in direction 3b, use a flathead screwdriver or similar device and push the clamp latch down. [Figure 32: Clamp Latch - Detail](#) provides a clearer view of the clamp latch and the direction in which you have to push the latch to move it in direction 3b.

Figure 31: Positioning the Clamp

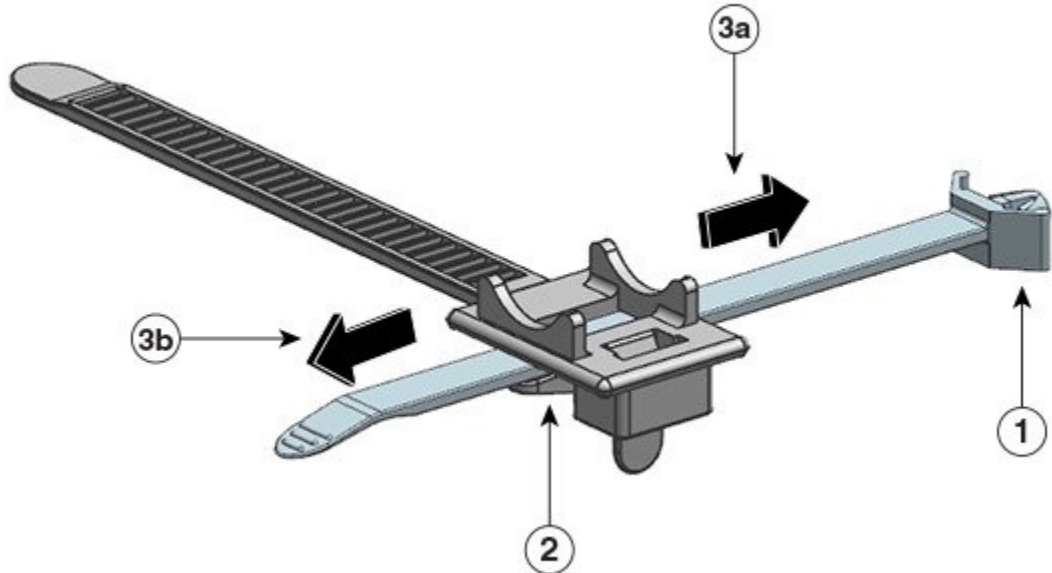

355312

1	The end that is fixed to the power supply module	3a and 3b	Directions in which the clamp can be moved, towards the power supply and away from it.
2	Clamp Latch	-	-

Figure 32: Clamp Latch - Detail

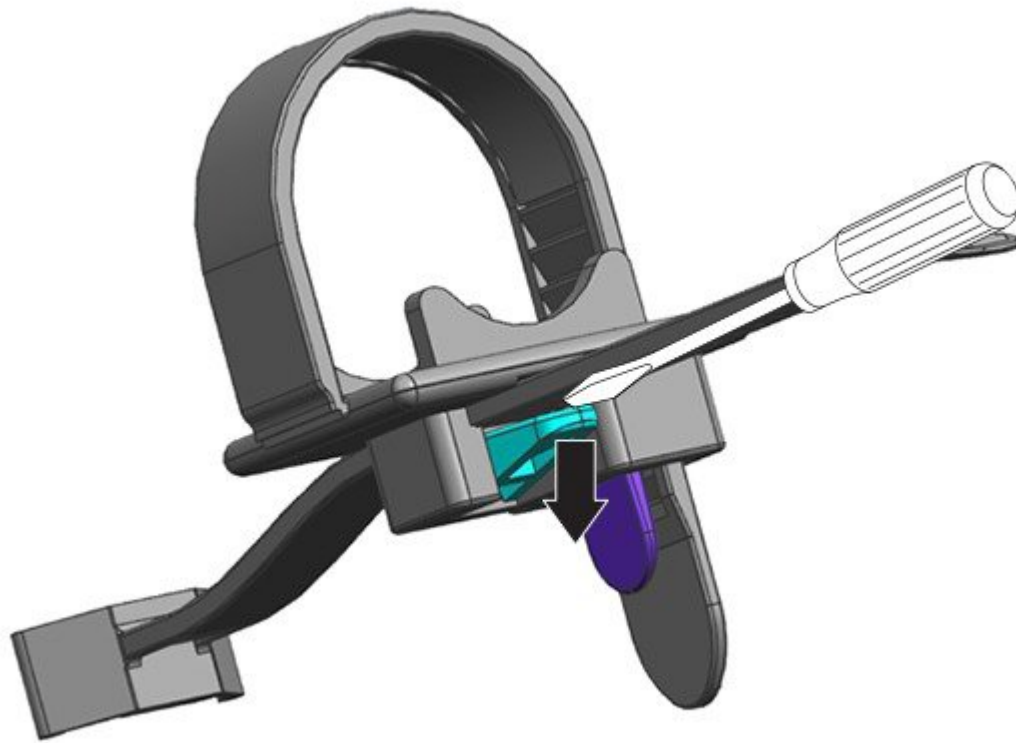

355189

Inserting and Tightening the Retainer Strip

The flexible retainer strip inserts into the clamp hole and should be tightened around the power cord.

To loosen or remove the flexible retainer strip, position a flathead screwdriver or similar device between the flexible retainer strip and the retainer strip latch and push the latch away from the flexible retainer strip .

Figure 33: Flexible Retainer Strip

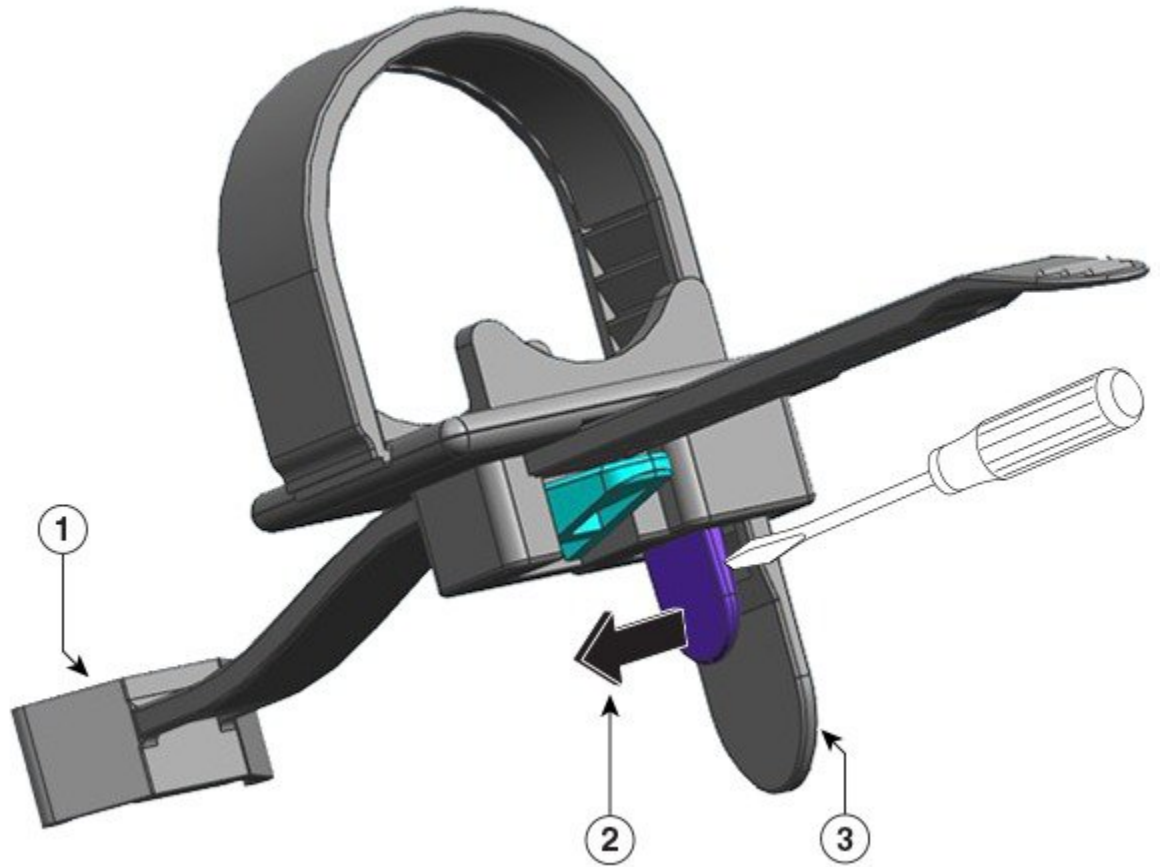

355188

1	The end that is fixed to the power supply module	3	Flexible retainer strip
2	Direction in which to push the retainer strip latch, to loosen or remove the strip from the power cord (away from the retainer strip that is behind it)	-	-

The following figure shows how the flexible retainer strip inserts into the clamp hole.



Note The illustration does not include the chassis, for the sake of clarity.

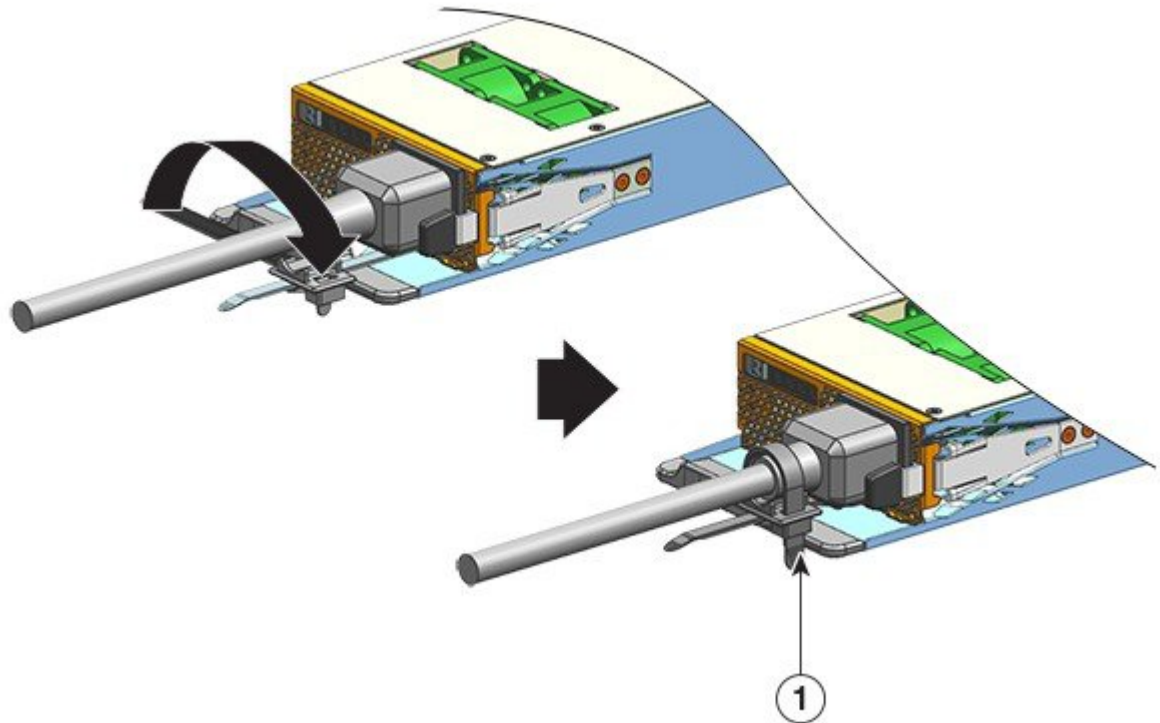

355182

1	Retainer strip strapped into place	-	-
---	------------------------------------	---	---

Removing and Installing a DC-Input Power Supply Module

This section describes how to remove and install a DC-input power supply module.

Before you begin, read [Power Connection Guidelines for DC-Powered Systems](#), on page 39.

Required Tools and Equipment

Obtain these tools:

- Number one Phillips screwdriver.
- 10 mm torque driver, with a three-inch shaft, at a minimum.
A torque driver helps tighten nuts in a precise manner and prevents overtightening.
- Nut driver, with a three-inch shaft, at a minimum, to loosen nuts.
- Wire-stripping tool.
- Wire-crimping tool.

Obtain the following parts for each DC-input power supply module you are going to install - they are not shipped with the power supply module:

- Five standard, dual-hole crimp lugs that meet these specifications:

- 1/4-inch bolt or stud size.
 - 5/8-inch hole spacing.
 - A landing size of 0.5 inches (1.2 cms) width and 1.125 inch (2.9 cms) depth.
 - Compatible with the wire size you will use (Lugs are wire size specific).
-
- Four DC-input power source cables. The wire gauge is determined by local electrical codes and restrictions.
 - One grounding wire.
 - Five heat-shrink sleeves.

Removing a DC-Input Power Supply Module

When removing a DC-input power supply module, you will need access to the terminal block of the module to disconnect the DC-input wires. If the front panel of the chassis has limited access because of other interfering cables, consider removing the module from the chassis before disconnecting the DC-input wires. If you do have clear access to the terminal block, you can disconnect the DC-input wires and then remove the module from the chassis. In either case (whether you have access to the front panel or not), you must begin by completing all the steps described in [Powering Down the DC-Input Power Supply](#). Proceed with the next task depending on your setup.

The procedures to disconnect DC-input wires and to remove the module from the chassis have been described in [Disconnecting the DC-Input Wires](#), on page 114 and [Removing a DC-Input Power Supply Module from the Chassis](#), on page 117.

Powering Down a DC-Input Power Supply Module

To power down a DC-input power supply module, follow the steps described here.

Before you begin



Warning **Statement 1073**—No User-Serviceable Parts

There are no serviceable parts inside. To avoid risk of electric shock, do not open.

Procedure

-
- Step 1** Press the power button on the power supply module for two seconds to turn it off. Check that the OUTPUT LED is off.

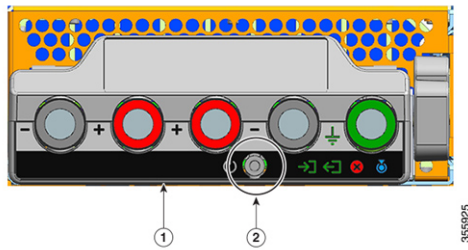

1	Front panel of the C9400-PWR-3200DC	2	Power button
---	-------------------------------------	---	--------------

Step 2 Locate the circuit breaker on the panel board that services the DC circuit, and switch the circuit breaker to the OFF position.

Step 3 Check that the INPUT LED on the power supply module is off.

The FAIL LED is illuminated for two to three seconds after DC input is disconnected through a circuit breaker.

Disconnecting the DC-Input Wires

To disconnect the DC-input wires, follow the steps described here.

Before you begin



Warning **Statement 1073**—No User-Serviceable Parts

There are no serviceable parts inside. To avoid risk of electric shock, do not open.

Procedure

Step 1 Using a number one Phillips screwdriver, loosen the captive installation screw on the terminal block cover and lift to open.

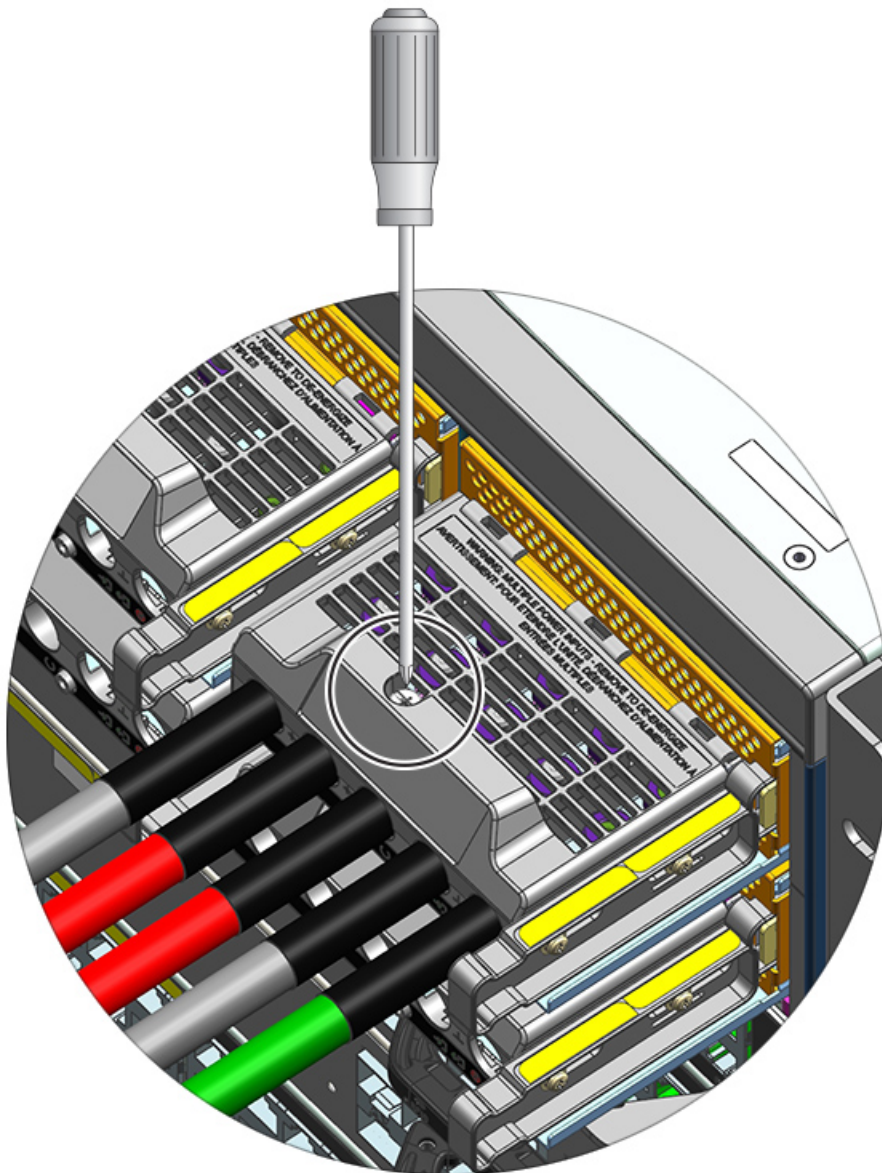

355926

Step 2 Using a nut driver, loosen the two nuts of one terminal slot at a time. After the lugs are removed, place the nuts back on the terminal posts and tighten.

The nut driver you are using must have at least a three-inch shaft, to clear the height of the terminal block cover and enable you to loosen or tighten the nuts in the terminal slots.

Disconnect the DC-input wires from the terminal block first, and disconnect the ground wire last.

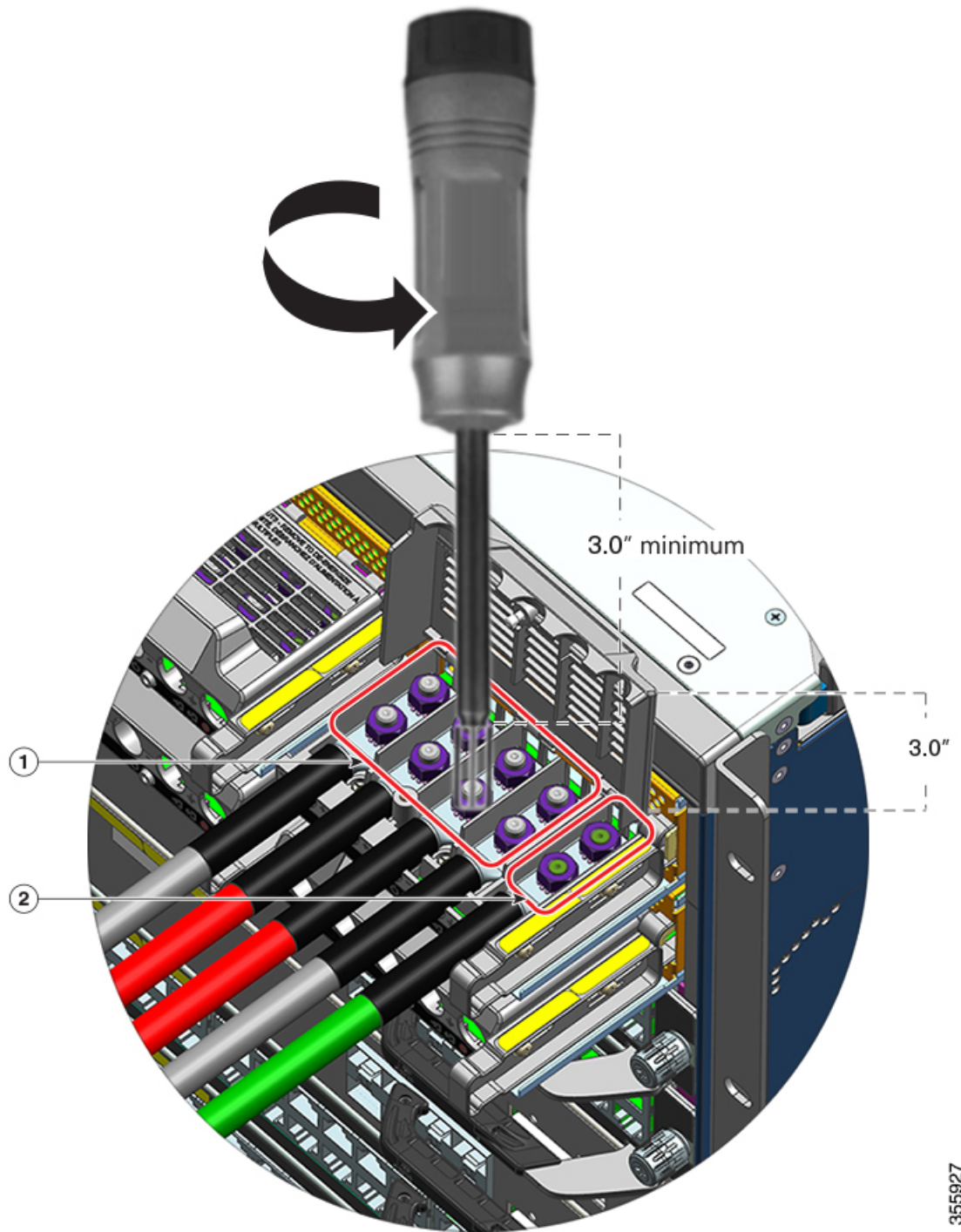

<p>1 Terminal slots of the DC-input wires, which should be removed first</p>	<p>2 Terminal slots of the ground wire, which should be removed last</p>
--	--

3555927

Step 3 Close the terminal block cover and finger-tighten the captive installation screw (approximately 0.25 Nm).

Removing a DC-Input Power Supply Module from the Chassis

To remove a DC-input power supply module from the chassis, follow the steps described here.

Before you begin



Warning Statement 1073—No User-Serviceable Parts

There are no serviceable parts inside. To avoid risk of electric shock, do not open.

Procedure

Step 1 Pull out the latch on the module, to unlock it.

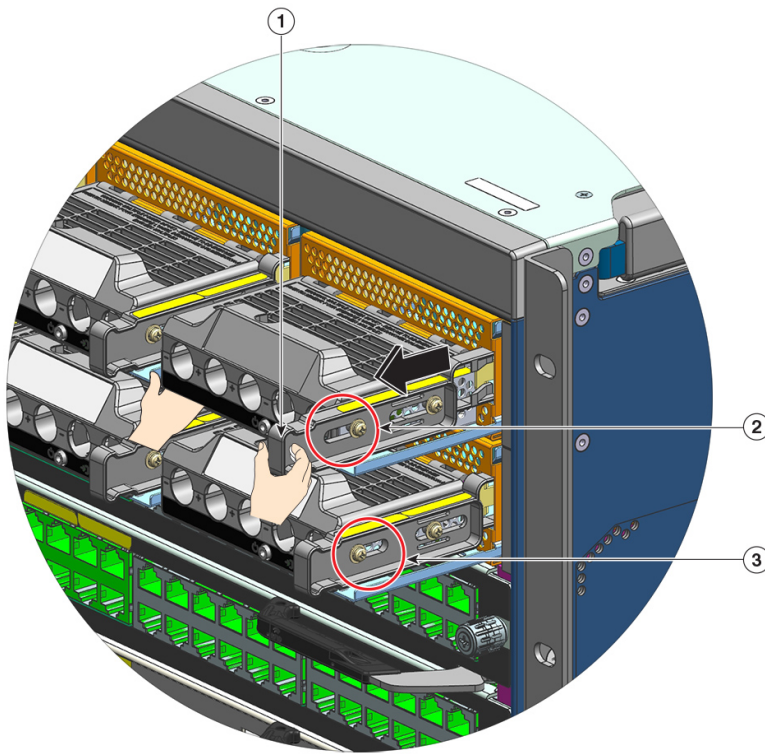

1	Release latch to be pulled out (towards yourself)	3	Comparative location of the nut on a module where the release latch has not been pulled out.
2	Location of the nut on the side when the release latch has been pulled	-	-

- Step 2** Grasp the terminal block with one hand and place your other hand underneath as you slide the power supply module out of the bay.

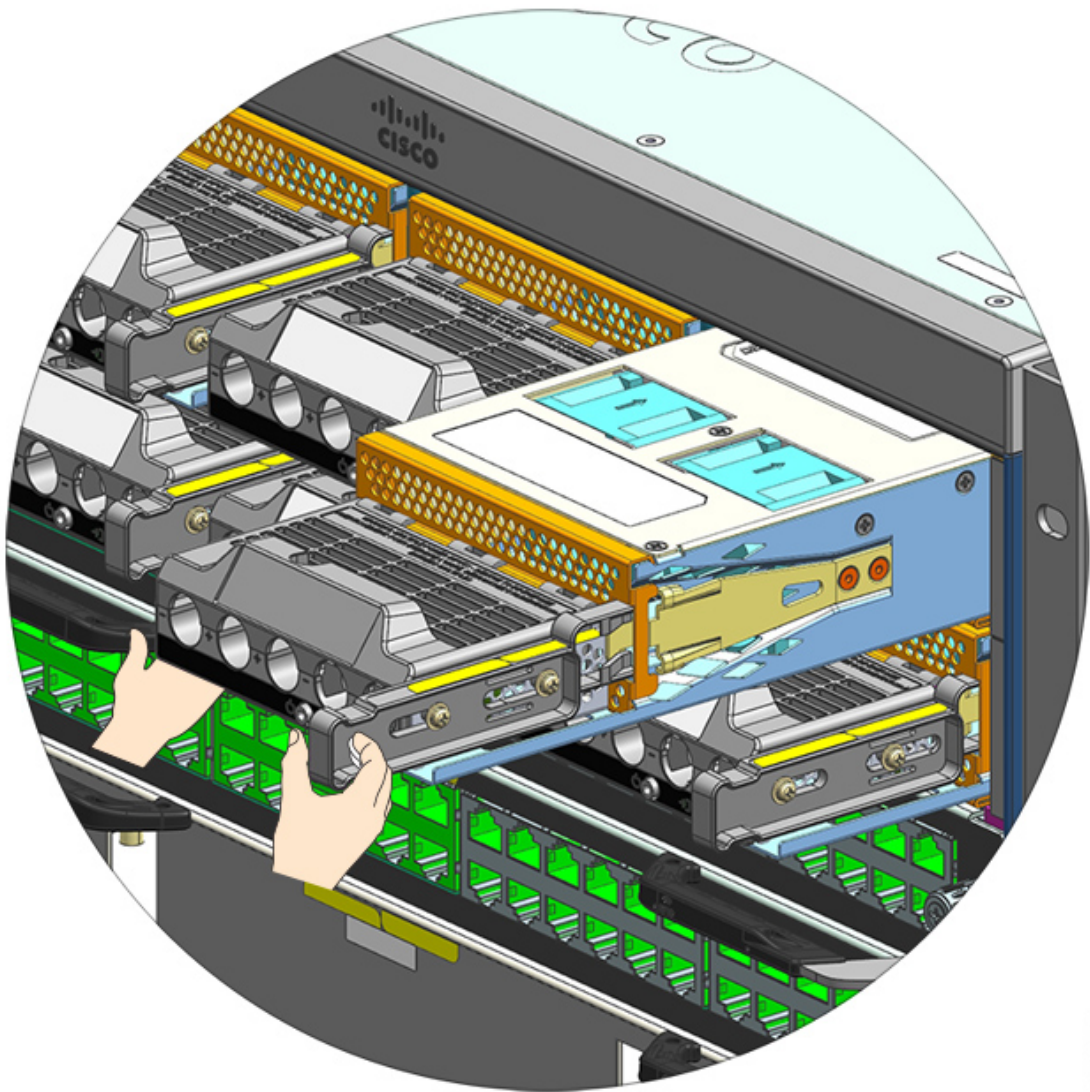

355929

- Step 3** Install another power supply module. If you are not going to install another module, you must install a blank cover (C9400-PWR-BLANK) to maintain proper airflow through the chassis.

Caution Do not leave any power supply slot open for any amount of time while the system is powered up. Prior to inserting a new power supply unit, for instance, when you are replacing a unit, ensure there are no foreign, conductive, or other objects, or debris in the slot.

Installing a DC-Input Power Supply Module

When installing a DC-input power supply module, you will need access to the terminal block of the power supply module in order to connect the DC-input wires. If the front panel of the chassis has limited access because of other interfering cables, consider connecting the DC-input wires to the terminal block, before you install the power supply module in the chassis. If you do have clear access to the terminal block, you can install the power supply module in the chassis first and then connect the DC-input wires.

The procedure to install the module in the chassis and the procedure to connect the DC-input wires have been described in [Installing a DC-Input Power Supply Module in the Chassis, on page 119](#) and [Connecting the DC-Input Wires, on page 121](#). You can complete either task first and then move on to the next, and finally power up the power supply module.

Installing a DC-Input Power Supply Module in the Chassis

To install a DC-input power supply module in the chassis, follow the steps described here.

Before you begin



Warning **Statement 1073**—No User-Serviceable Parts

There are no serviceable parts inside. To avoid risk of electric shock, do not open.

Procedure

- Step 1** Remove the power supply blank cover from the chassis, if one is installed.
- Step 2** Remove the new or replacement module from its packaging.
- Step 3** Grasp the module with one hand. With your other hand, push in the latch on the module.

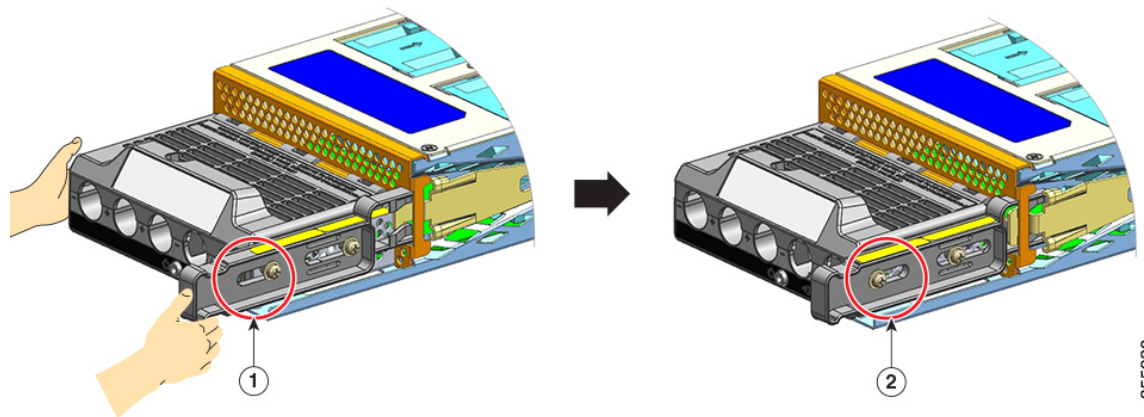

1	Position of the nut on the side of the release latch <i>before</i> the latch is pushed in	2	Position of the nut on the side of the release latch <i>after</i> the latch is pushed in.
---	---	---	---

- Step 4** Grasp the terminal block with one hand. Place your other hand underneath as you slide the power supply module into the bay.

You will hear an audible *click* sound, which indicates that the module is locked into place, and connected with the backplane. Only the terminal block housing is not flush with the chassis.

If you do not push the release latch in before you slide the module into the bay, you will not hear the click sound, but this is an acceptable way of installing the module.

If the module is properly locked in place, you should not be able to remove the module without releasing the latch.

The following figure shows how a power supply module slides into the bay:

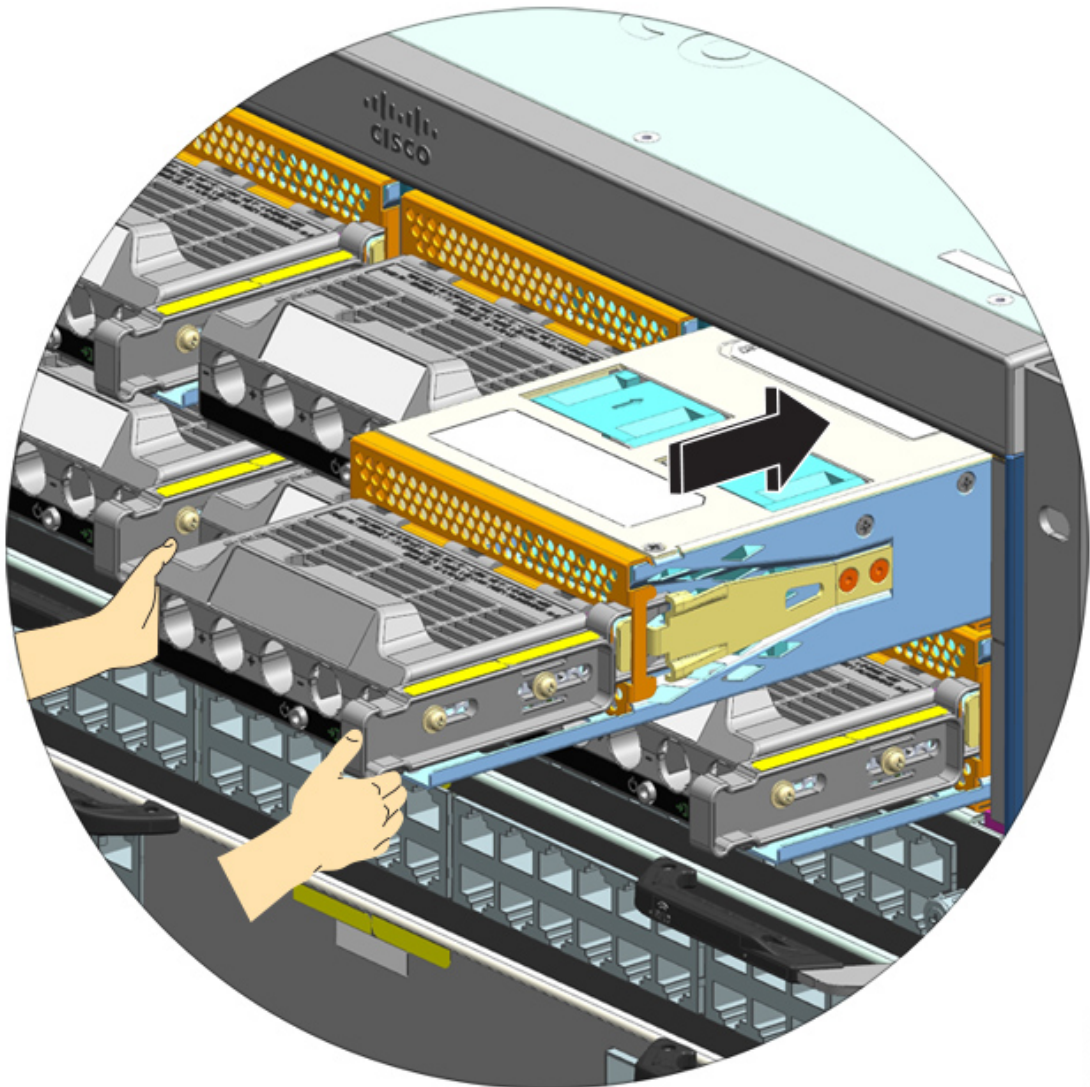

355931

The following figure shows a power supply module that is fully installed in the bay:

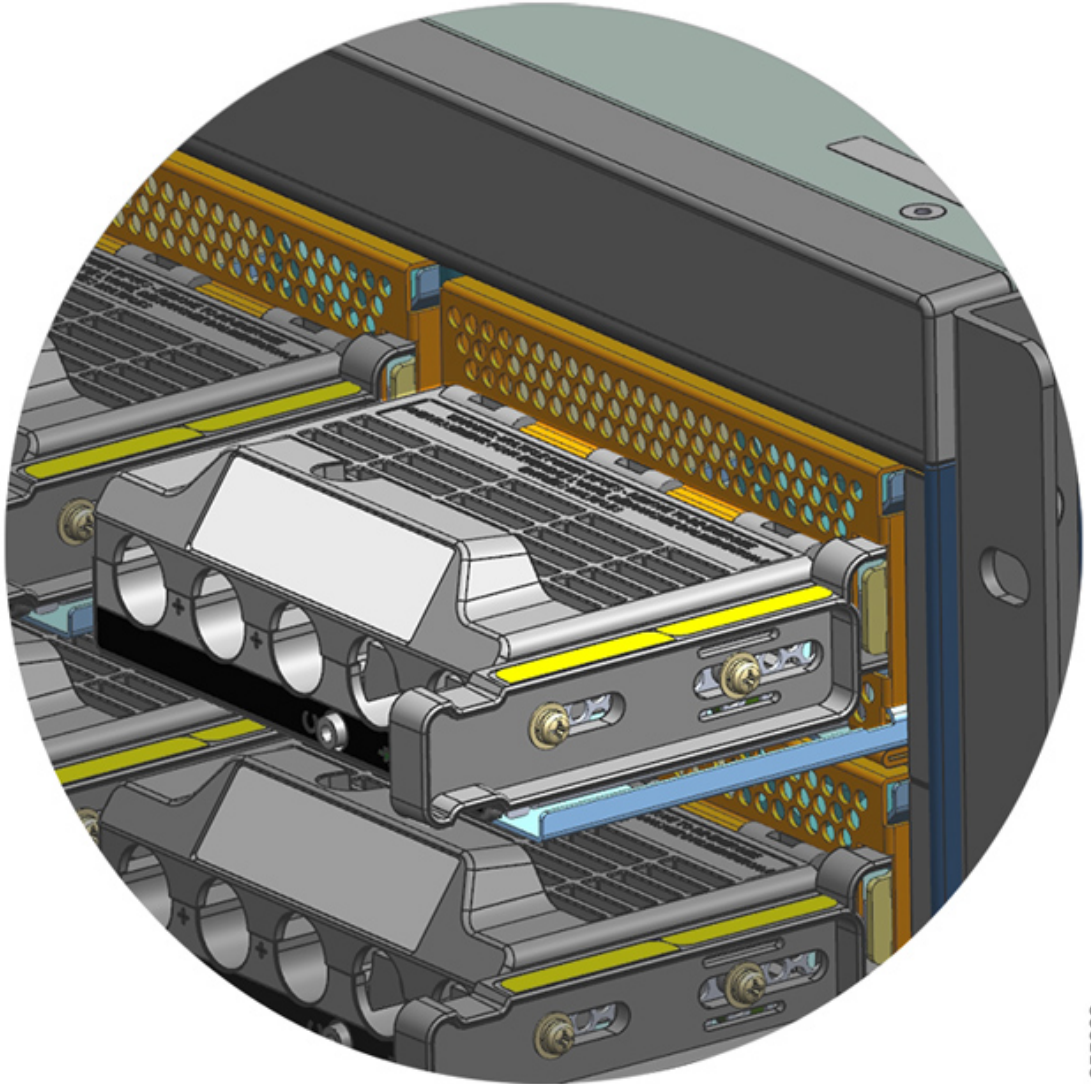

355932

Connecting the DC-Input Wires

To connect to the DC-input power source, follow the steps described here.

Before you begin



Warning **Statement 1073**—No User-Serviceable Parts

There are no serviceable parts inside. To avoid risk of electric shock, do not open.

Procedure

Step 1 Locate the circuit breaker on the panel board that services the DC circuit, and switch the circuit breaker to the OFF position.

Step 2 Prepare the DC-input wires and the grounding wire. Crimp the lugs to the cable ends according to the lug manufacturer's direction and your local electrical codes for installation.

Use a heat-shrink sleeve to ensure that there is no exposed wiring extending from the terminal block, when installed.

If you are using cables of different colors for your DC-input wires, we recommend one color for all the positive circuits, a second color for all the negative circuits, and a third color, which is normally solid green or green with yellow stripes, for the safety ground connection.

Step 3 Using a number one Phillips screwdriver, loosen the captive installation screw on the terminal block cover.

Step 4 Using a nut driver, loosen and remove the two nuts in the terminal slot meant for grounding, and set them aside.

The nut driver you are using must have at least a three-inch shaft, to clear the height of the terminal block cover and enable you to loosen or tighten the nuts in the terminal slots.

Warning **Statement 1046**—Installing or Replacing the Unit

To reduce risk of electric shock, when installing or replacing the unit, the ground connection must always be made first and disconnected last.

If your unit has modules, secure them with the provided screws.

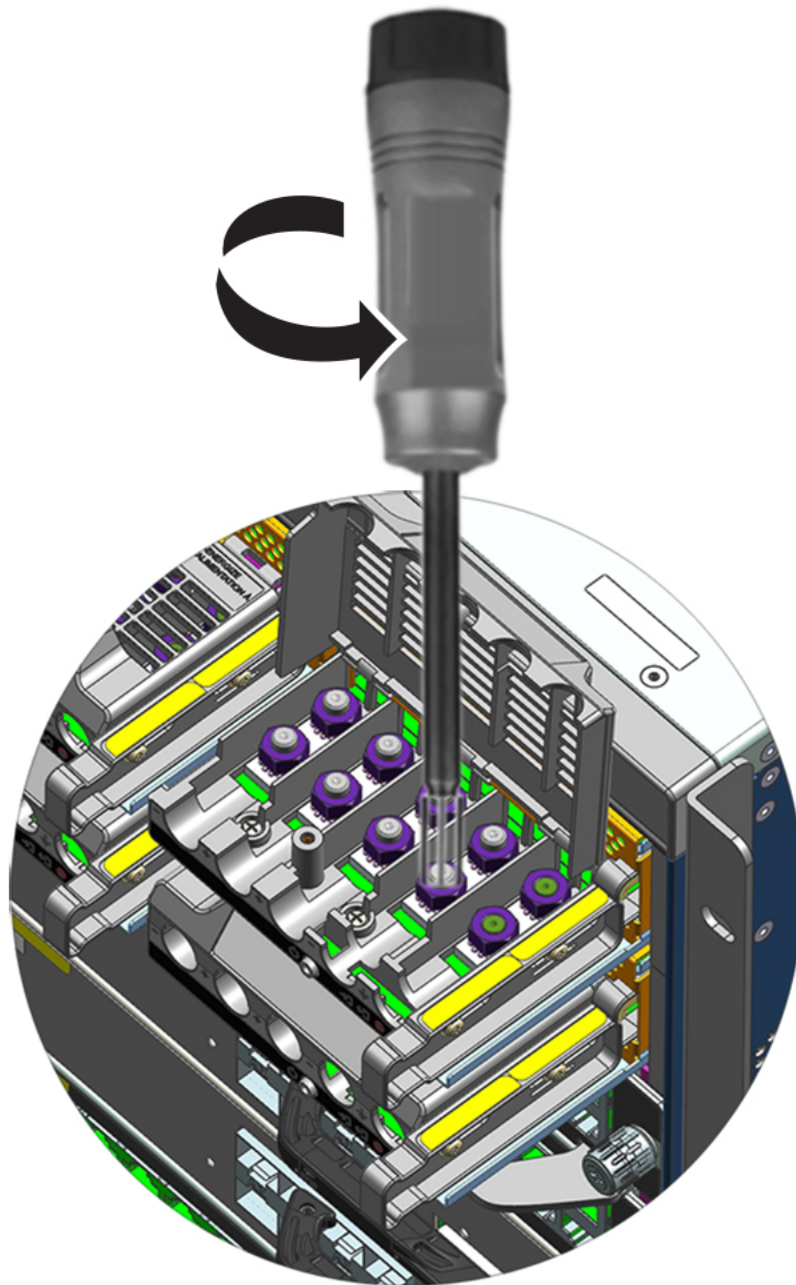

355933

Step 5 Attach the lug to the two posts, secure with the two nuts, and tighten with the torque driver. The fastening torque is between 2.0 and 2.8 Nm. Do not overtorque.

Note Always use a torque driver when you have to tighten nuts; it prevents you from overtightening them.

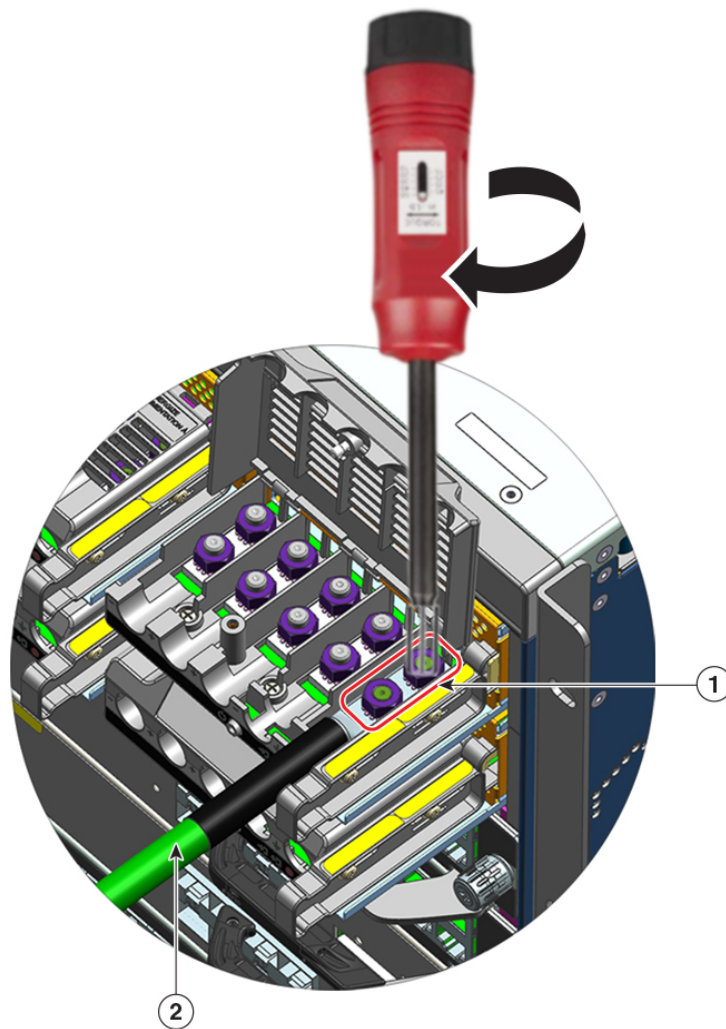

355934

1 Lug secured with the two nuts

2 Grounding wire with heat-shrink sleeve

Step 6 Attach the four DC-input power source cables similarly.

When facing the terminal block, the circuits are in the following order from left to right: negative (- A), positive (+A), positive (+ B), and negative (-B).

-A and +A form one DC input, and + B and -B form another. Each DC input can be powered either from separate sources, or a suitable single source.

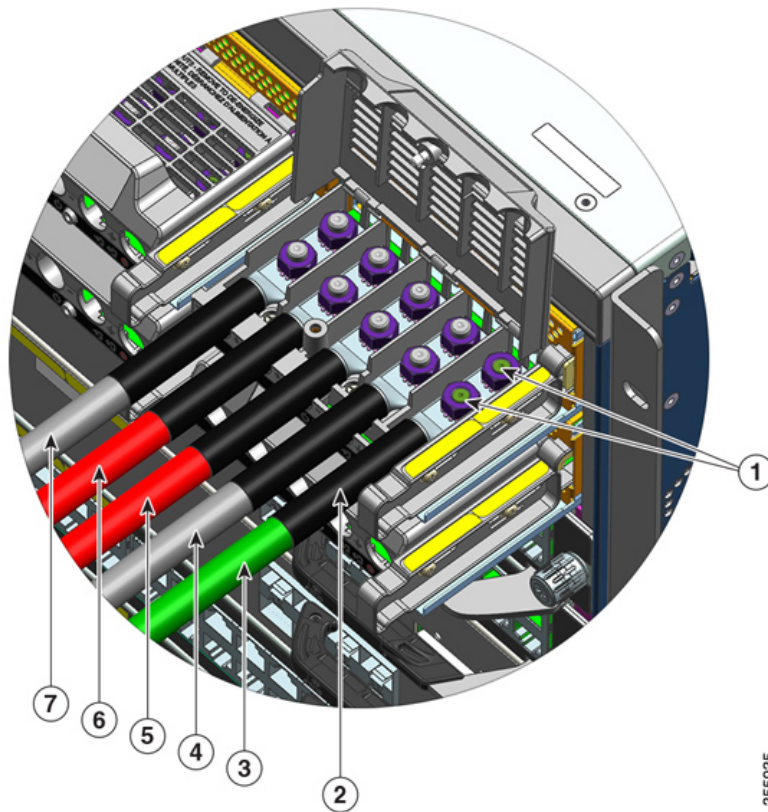

1	Lug secured with two nuts	5	DC-input wire for positive circuit (+ B)
2	Heat-shrink sleeve on all the wires	6	DC-input wire for positive circuit (+A)
3	Grounding wire	7	DC-input wire for negative circuit (- A)
4	DC-input wire for negative circuit (-B)	-	-

Step 7 Close the terminal block cover and finger-tighten the captive installation screw (approximately 0.25 Nm).

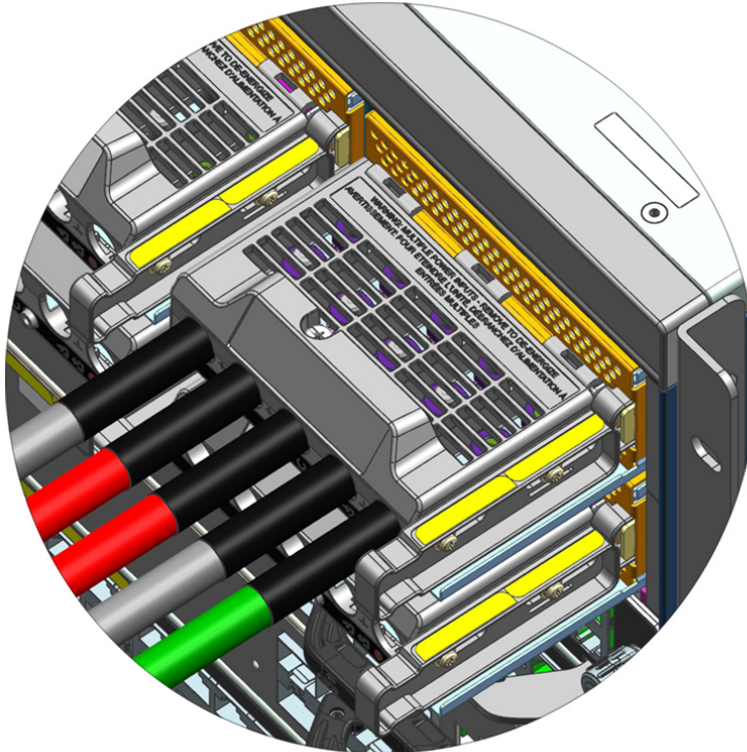

355936

Powering Up a DC-Input Power Supply Module

After you have installed the power supply module in the chassis and connected the DC-input wires, follow the steps described here to power up the module and verify that the module is installed correctly.

Before you begin



Warning **Statement 1073**—No User-Serviceable Parts

There are no serviceable parts inside. To avoid risk of electric shock, do not open.

Procedure

- Step 1** For the powered down circuits connected to the power supply modules, turn on the power at the circuit breaker. The FAIL LED is illuminated for two to three seconds after DC input is applied through a circuit breaker.
- Step 2** Check that the INPUT and OUTPUT LEDs on the power supply module are green.

Note DC-input power supply modules are shipped with the power button in the default auto-on mode, which means that the module automatically starts on application of DC-input power. When you install a new or replacement module straight out of the box, you do not have to press the power button.

- Step 3** Verify the polarity by measuring the voltage between the DC cable leads.
 When measuring, check that the positive (+) lead and the negative (-) lead match the + and - labels on the DC-input power supply module's terminal block.
 If the DC inputs are powered from separate sources, also check that you have wired the cables straight across to their respective A source and B source, and respective negative and positive terminals. Crossed positive or negative cables constitute a severe safety hazard.
- Step 4** Verify the module's operation by performing the steps described here: [Verifying the Power Supply Module Installation, on page 129](#).

Removing and Installing a Power Supply Blank

If a power supply bay in a chassis is unused, you must cover it with a power supply blank cover to maintain proper airflow through the chassis. (Part number C9400-PWR-BLANK=).

Figure 34: Front View of a Power Supply Blank Cover

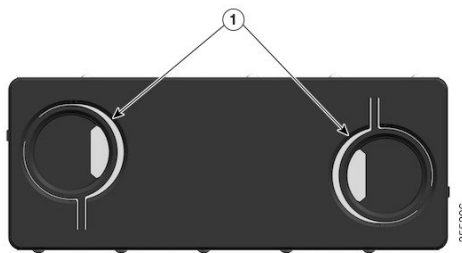

1	<p>Two finger holes with rings on the blank cover.</p> <p>To remove the blank cover, use the finger holes to hold the blank cover and squeeze both rings towards each other.</p> <p>To install the blank cover, hold the blank cover by the outside edges and push straight into the bay; alternatively, use the finger holes to hold the blank cover and push straight into the bay, but do not squeeze the rings.</p>	-	-
---	---	---	---

Removing a Power Supply Blank Cover

To remove the blank cover from a bay, use the finger holes to hold the blank cover (with your thumb and index fingers), squeeze both rings towards each other and slide the cover out of the bay.

Figure 35: Removing a Power Supply Blank Cover

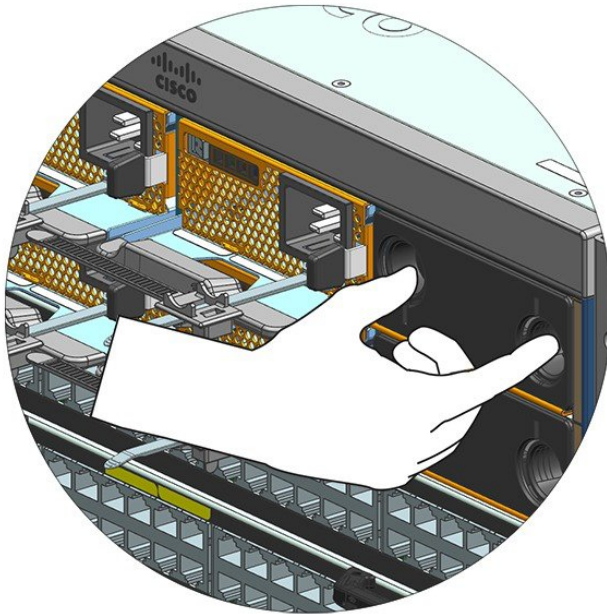

355310



Caution Do not leave any power supply slot open for any amount of time while the system is powered up. Prior to inserting a new power supply unit, for instance, when replacing the unit, ensure there are no foreign, conductive or other objects, or debris in the slot.

Installing a Power Supply Blank Cover

To install a power supply blank cover, push the blank cover straight and into the bay. You will hear it snap into place when installed correctly. You can hold the blank cover by the outside edges when you perform this task; alternatively, use the finger holes to hold the blank cover, but do not squeeze the rings.

Figure 36: Installing a Power Supply Blank Cover

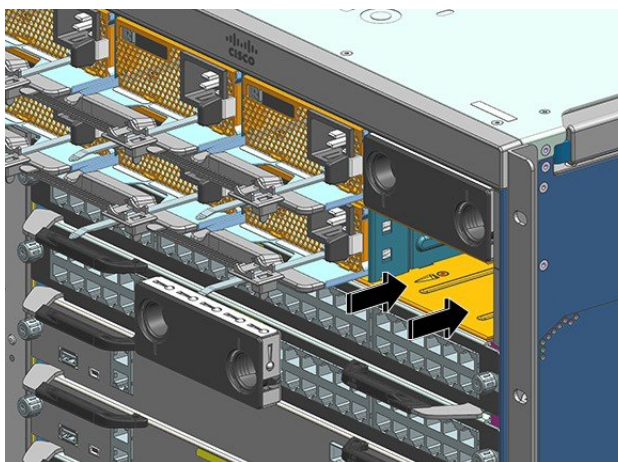

355308

Figure 37: Power Supply Blank Cover Installed

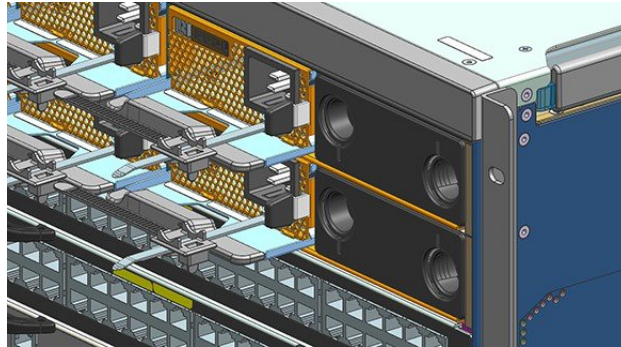

Note Power supply blank covers can be placed in any slot when fewer than eight power supplies are installed in a chassis.

Verifying the Power Supply Module Installation

Procedure

-
- Step 1** Verify the power supply operation by checking the power supply's front-panel LEDs. You should see the following:
- The INPUT LED is green.
 - The OUTPUT LED is green if it is an active module and blinking green if it is a redundant module.
 - The FAIL LED is off.
- Step 2** Check the power supply and system status from the system console by entering **show power** command in privileged EXEC mode.
- ```
Switch# show power
```
- Step 3** If the LEDs or **show power** privileged EXEC command output indicate a power problem or other system problem, see the [Troubleshooting a Power Supply Module, on page 134](#) section for more information.
-







## CHAPTER 7

# Troubleshooting

---

- [About this Section, on page 131](#)
- [System Boot Verification, on page 131](#)
- [Using LEDs to Identify Startup Problems, on page 132](#)
- [System Messages, on page 133](#)
- [Troubleshooting with Software , on page 133](#)
- [Troubleshooting a Power Supply Module, on page 134](#)
- [Troubleshooting the Fan Tray Assembly, on page 137](#)
- [Troubleshooting High Temperature Alarms , on page 139](#)
- [Troubleshooting the Line Card, on page 140](#)
- [Troubleshooting Supervisor Modules, on page 140](#)
- [Finding the Serial Number, on page 144](#)
- [Contacting the Cisco Technical Assistance Center, on page 146](#)

## About this Section

This chapter describes how to perform basic troubleshooting on Cisco Catalyst 9400 Series Switches. Problems with the initial startup are often caused by a line card that has become dislodged from the backplane or a power cord that is disconnected from the power supply.

Although temperature conditions above the maximum acceptable level rarely occur at initial startup, some environmental monitoring functions are included in this chapter because they also monitor power supply output voltages.



---

**Note** This chapter covers only the chassis component hardware aspects of troubleshooting. For software configuration issues, refer to the software configuration guide

---

## System Boot Verification

When the initial system boot is complete, verify the following:

- That the system software boots successfully

Hook up a terminal and view the startup banner. Use an RJ-45-to-RJ-45 rollover cable to connect the console port to a PC with terminal emulation software set for 9600 baud, 8 data bits, no parity, and 1 stop bit. Watch for any system messages after startup.

- That the power supplies are supplying power to the system

The power supply's LED should be green. Use the **show environment** Cisco IOS command to view power supply activity.

- That the system fan assembly is operating

Listen for fan activity. The Fan tray LED should be green during operation. Use the **show environment** Cisco IOS command to view fan tray activity.

- That the supervisor and all line cards are installed properly in their slots, and that each initialized without problems.

If all of these conditions are met and the hardware installation is complete, refer to the software configuration guide and command reference publications for your switch so that you can troubleshoot the software.

If any of these conditions is not met, use the procedures in this chapter to isolate and, if possible, resolve the problem.

## Using LEDs to Identify Startup Problems

The key to success when troubleshooting the system is to isolate the problem to a specific system component. Your first step is to compare what the system *is doing* with what *it should be doing*. All system states in the startup sequence are indicated by LEDs. By checking the LEDs, you can determine when and where the system failed in the startup sequence. If you have problems after the switch is on, refer to the following subsystem troubleshooting information and the configuration procedures in the software configuration guide for your switch.

After you connect the power cords to your switch, follow these steps to determine whether your system is operating properly:

### Procedure

#### Step 1

Check the power supply LEDs:

The INPUT LED should turn green when power is applied to the supply. The LED should remain on during normal system operation.

If the INPUT LED does not light, or if the LED labeled FAIL lights, see the “Troubleshooting the Power Supply” section.

**Note** If a power supply is installed and not connected to a power source, power supply LEDs are not lit.

#### Step 2

Listen for the system fan assembly. The system fan assembly should be operating whenever system power is on. If you do not hear it when the switch is on, see the “Troubleshooting the Fan Assembly” section.

#### Step 3

Check that the LEDs on the supervisor module light as follows:

- The STATUS LED flashes amber once and stays amber during diagnostic boot tests.

- It turns green when the module is operational (online).
- If the system software is unable to start up, this LED turns red.

If the LED is red, connect a console to the management port and use the **show environment** command to check for possible problems.

- The MANAGEMENT LED turns green when the module is operational (online) and a link is established with another network device. If no signal is detected, the LED turns off.
- If there is a problem with the supervisor module, try reseating the supervisor module in the chassis and restarting the switch. For more troubleshooting information, see the “Troubleshooting Supervisor Modules” section.
- Verify that the STATUS LEDs on each line card is green when the supervisor module completes initialization.

This LED indicates that the supervisor module and line cards are receiving power, have been recognized by the supervisor module, and contain a valid Flash code version. However, this LED does not indicate the state of the individual interfaces on the line cards. If a STATUS LED is red, try reseating the line card or supervisor module and restarting the switch. For more information, see the “Troubleshooting Line Cards” section. If you determine that the line card is not operating, contact Cisco TAC as described in the “Some Problems and Solutions” section.

- If the boot information and system banner are not displayed, verify that the terminal is set for 9600 baud, 8 data bits, no parity, and 1 stop bit and connected properly to the console port.

---

## System Messages

System messages appear on the console if you have enabled console logging or appear in the syslog if you have enabled syslog. Many messages are for informational purposes only and do not indicate an error condition. Enter the `show logging` command to display the log messages. To better understand a specific system message, refer to the system message guide for your software release.

## Troubleshooting with Software

Many problems can be identified with CLI commands, and following sections will mention them as appropriate.

Certain problems can be due to not having the right software to support your hardware. For the most recent software release to get the current recommended version for a particular system component, please refer to the release notes at: <https://www.cisco.com/c/en/us/support/switches/catalyst-9400-series-switches/products-release-notes-list.html>

# Troubleshooting a Power Supply Module

## Useful Cisco IOS Commands - Power Supply

You may use the following Cisco IOS commands in the privileged EXEC mode, to monitor the status, load, and activity of a power supply module.

- Switch# `show power detail`

If FAIL LED is red, the `show power` command output reports the power supply module as faulty.

- Switch# `show idprom power-supply slot-number`

- Switch# `show module`

If the `show module` command output shows a message that states "not enough power for module," check the corresponding power supply specifications here: [Power Supply Specifications, on page 153](#). There may be a problem with the power source itself.

## Troubleshooting an AC-Input Power Supply

To help isolate a power subsystem problem, follow these steps:

### Procedure

- 
- Step 1** The INPUT should be solid green for normal operation. If the INPUT LED is off, take the following steps:
- a) Ensure that the power supply is flush with the back of the chassis by gently inserting it all the way in until it stops. You should feel the retaining metal latch, on its right side, click into place. The unit should not be removable without depressing this latch towards it.
- Note** You should be unable to remove the power supply from the system when the power cord is fully inserted and installed with the cord retainer.
- b) Unplug the power cord by loosening the cord retainer and physically reinstalling the power supply, plug in the power cord and tighten the cord retainer around it.
  - c) If the INPUT LED remains off, there may be a problem with the AC source or the power cable connection. Also check the circuit breaker of the AC source. Connect the power cord to another power source if one is available. Verify that the source power is within the acceptable specifications of the power supply.
  - d) If the LED remains off after you connect the power supply to a new power source, replace the power cord.
  - e) If the LED still fails to light when the switch is connected to a different power source with a new power cord, the power supply is probably faulty. You may need to replace the power supply.
- Step 2** The OUTPUT LED should be solid green for normal operation. Blinking green indicates that the unit is asleep in standby mode.
- Step 3** If the FAIL LED is red, take the following steps:
- a) Remove the power supply from the bay and visually inspect the rear of the power supply module connector. If there is no damage, try installing it in another empty power supply bay, if available. Do not touch the back of the power supply module during this inspection. If the OUTPUT LED turns green, the problem

may lie with the first power supply bay and not the power supply module. Call Cisco Technical Assistance Center ([Cisco Support](#)) for further instructions.

- b) If a second power supply is available, install it in the second power supply bay.
- c) Check that the INPUT LED is on for the additional power supply. Check that the FAIL LED is off.
- d) If the LEDs are not on, repeat the previous procedure to troubleshoot the second power supply

**Step 4** Contact Cisco Technical Assistance Center.

If you are unable to resolve the problem, or if you determine that either a power supply or backplane connector is faulty, contact Call Cisco Technical Assistance Center ([Cisco Support](#)) for instructions.

---

## Troubleshooting a DC-Input Power Supply

To help isolate a power subsystem problem, follow these steps:

### Procedure

---

**Step 1** The INPUT LED should be solid green for normal operation. If the INPUT LED is off, perform the following steps:

- a) Check the DC source.
  - 1. Check that the circuit breaker of the DC source is ON.
  - 2. Connect the cables to another power source if one is available. Verify that the source power is within the acceptable specifications of the power supply.
  - 3. Check that you have connected both the DC inputs to a suitable DC source. The power supply module is not designed to function with just one DC input.
  - 4. If you are using a single source, check that it is capable of providing 3500 W of DC-input power. If it is two different sources, check that each source is able to provide 1750 W of DC-input power.
  - 5. Ensure that the DC source is capable of providing a minimum of -40 V to the input terminals of the DC power supply module. .
- b) Check the DC-input cable connections
  - 1. Check that the lugs are fastened properly and torqued to between 2.0 and 2.8 Nm.
  - 2. Check that the polarity of the DC-input cables is not reversed. For more information, see [Power Connection Guidelines for DC-Powered Systems, on page 39](#)
  - 3. If you are using a separate source for each DC input, check that you have not crossed the cables (reversed positive or negative inputs).

**Note** If the INPUT LED still fails to light, the power supply module is probably faulty. You may have to replace it.

**Step 2** The OUTPUT LED should be solid green for normal operation. Blinking green indicates that the unit is asleep in standby mode. If the OUTPUT LED is off, perform the following steps:

- a) Check if you have pressed the power button for two seconds to turn on the module.
- b) Check if the INPUT LED is on; if it is not, follow the steps to troubleshoot the INPUT LED first (Step 1).
- c) Check if the release latch has been pushed in to lock it.

**Step 3**

The FAIL LED should be OFF for normal operation. If the FAIL LED is red, perform the following steps:

- a) Check the power button.

If the power button on the front panel of the module is turned off after DC input is applied, the FAIL LED will be solid red until you press the power button for two seconds to turn it on again.

- b) Inspect the module.

Remove the power supply module from the bay and visually inspect the rear of the power supply module connector. If there is no damage, try installing it in another empty power supply bay, if available. Do not touch the back of the power supply module during this inspection. If the OUTPUT LED turns green, the problem may lie with the first power supply bay and not the power supply module. Call Cisco Technical Assistance Center ([Cisco Support](#)) for further instructions.

- c) Test with another spare.

If a second power supply module is available, install it in the second power supply bay.

1. Check that the INPUT LED is on for the second power supply, and that the FAIL LED is off.
2. If the INPUT LEDs for this second power supply is not on, repeat the procedure to troubleshoot INPUT LED of the second power supply (Step 1).
3. If the FAIL LED for this second power supply is on, repeat steps to troubleshoot the FAIL LED (Step 3).

**Step 4**

Contact Cisco Technical Assistance Center.

If you are unable to resolve the problem, or if you determine that either a power supply or backplane connector is faulty, contact Call Cisco Technical Assistance Center ([Cisco Support](#)) for instructions.

---

## Restoring the Default Mode of the Power Button for a DC Power Supply Module

If you are unsure of whether the power button of a DC-input power supply module is in the auto-on mode or the protected mode, you can restore the default mode (auto-on). Begin by checking the following:

1. The number of power supply modules currently configured
2. If the 3.3-VDC standby output is active (applied)

Depending on the conditions that apply, take the required action to restore the default mode of the power button, as shown in the following table:

| Condition                                                                                                                                                 | Action Required to Restore Default Mode of the Power Button                                                                                                                                                                                                                                                                                                                                                                                                                                                                                                         |
|-----------------------------------------------------------------------------------------------------------------------------------------------------------|---------------------------------------------------------------------------------------------------------------------------------------------------------------------------------------------------------------------------------------------------------------------------------------------------------------------------------------------------------------------------------------------------------------------------------------------------------------------------------------------------------------------------------------------------------------------|
| Only one power supply module is configured, and it is a DC-input power supply module.                                                                     | <ol style="list-style-type: none"> <li>1. Switch off the DC circuit breaker for at least three seconds.</li> <li>2. Switch on the DC circuit breaker.<br/>The FAIL LED is illuminated for two to three seconds.</li> </ol> <p><b>Result:</b> The power supply module enables output power automatically, and the power button is in auto-on mode.</p>                                                                                                                                                                                                               |
| Multiple power supply modules are configured (AC and DC input) and<br>3.3-VDC standby output of the power supply modules (AC and DC input) is inactive.   | <ol style="list-style-type: none"> <li>1. Switch off the DC circuit breaker of the affected power supply module for at least three seconds.</li> <li>2. Switch on the DC circuit breaker of the affected DC-input power supply module.<br/>The FAIL LED is illuminated for two to three seconds.</li> </ol> <p><b>Result:</b> The power button is in auto-on mode.</p>                                                                                                                                                                                              |
| Multiple power supply modules are configured (AC and DC input) and<br>3.3-VDC standby outputs of one of the power supply modules is active <sup>3</sup> . | <ol style="list-style-type: none"> <li>1. Press the power button of the affected DC-input power supply module for two seconds, to turn it off.</li> <li>2. Switch off the circuit breaker of the affected DC-input power supply module.</li> <li>3. Remove and reinsert the DC-input power supply module after having its DC input physically disconnected or disabled for at least three seconds.</li> <li>4. Switch on the DC circuit breaker of the affected DC-input power supply module.</li> </ol> <p><b>Result:</b> The power button is in auto-on mode.</p> |

<sup>3</sup> Regardless of whether one or more AC-input or DC-input power supply modules in the system is off or on, if AC-input or DC-input power is applied, 3.3-VDC standby is active and distributed to all power supply modules in the chassis.

## Troubleshooting the Fan Tray Assembly



**Note** All fans must be operating or a failure will occur.

Environmental problems may initially appear to be problems with the fan tray. To help isolate a fan assembly problem, follow these steps:

## Procedure

---

- Step 1** Check the STATUS LED on the fan tray
- If the LED is off and the rest of the system is functioning, the fan tray is not getting power or is not seated correctly on the backplane.
  - If the LED is green, the fans are operating normally. There may be conditions impairing fan performance, but they are minimal in impact.
  - If the LED is amber, one fan has failed.
  - If the LED is red, two or more fans have failed. If LED remains red for more than one minute, fans are pushed to operate at full speed, causing loud noise levels.
  - If the LED is off and the fans are not running at all, make sure to insert it all the way and to tighten the screws.
- If you have serviced the fan from the front, ensure that the captive installation screws in the rear are also sufficiently tight. If you have serviced the fan from the rear, ensure that the captive installation screws in the front are also sufficiently tight.
- Fans may take a few seconds to start ramping up in speed.
- Step 2** Connect a terminal and determine the fan tray status shown by the **show environment status** privileged EXEC command command.
- The status and sensor columns read *good*—the STATUS is green
- The status and sensor columns read *marginal*—the STATUS is amber, one fan has failed.
- The status and sensor columns read *bad*—the STATUS is red, two or more fans have failed.
- Step 3** Determine whether the airflow is restricted; verify that the minimum rack clearance requirements are met. See [Air Flow](#), on page 28.
- Step 4** Determine whether the power supply is functioning properly.
- Step 5** Verify that the fan tray assembly is properly seated, by loosening the captive installation screws, removing the fan assembly, and reinstalling it.
- Note** There is a time constraint when you remove and replace the fan tray in a system that is powered on. The system can safely run without a fan tray only for 2 minutes. There is no time constraint in a system that is not powered on.
- Step 6** Restart the system.
- Step 7** Verify that all fans are operating. You should hear the fans at system start.
- 

## What to do next

If the system is still detecting a fan assembly failure, check for details using the Cisco IOS commands, save the logs, and contact the Cisco TAC for assistance.



## Useful Cisco IOS Commands - Fan Tray Assembly

You may use the following Cisco IOS commands in the privileged EXEC mode, to diagnose fan tray problems.

- To turn the blue beacons on:

```
Switch# hw-module beacon fan-tray on
```

To turn the blue beacons off:

```
Switch# hw-module beacon fan-tray off
```

- To display fan tray speeds:

```
Switch# configure terminal
Switch(config)# service internal
Switch(config)# end
Switch# test platform hardware chassis fantray {nebs-mode | service-mode | write }
```

- To display fan tray status:

```
Switch# show environment status
```

- To manually enter the NEBS mode:

```
Switch# configure terminal
Switch(config)# service internal
Switch(config)# end
Switch# test platform hardware chassis fantray nebs-mode on
```

To turn-off the NEBS mode:

```
Switch# configure terminal
Switch(config)# service internal
Switch(config)# end
Switch# test platform hardware chassis fantray nebs-mode off
```

## Troubleshooting High Temperature Alarms

A dirty air filter may cause overheating of the switch. Multiple board temperature sensors trigger alarm in case of overheating caused by dirty filter.

Inspect the air filter if the high temperature alarm goes off.

### Cleaning and Replacing Air Filters

The air filter removes dust from the room air drawn into the switch by the cooling fans. Once a month (or more often in industry environments), you should examine the air filter. If the filter appears dirty, you can either vacuum or replace it. If the filter appears worn or torn, dispose of it in a responsible manner and install a replacement air filter.



---

**Note** We recommend that you change the air filter every three months. However, examine the air filter once a month (or more often in dusty environments) and replace it if it appears to be excessively dirty or damaged. To comply with Telecordia GR-63-Core standard air filter requirements for NEBS deployments, the air filter must be replaced, not cleaned

---

## Troubleshooting the Line Card

Each line card has one STATUS LED that provides information about the module and one numbered PORT LINK LED for each port on the module. Refer to [Cisco Catalyst 9400 Series Line Card LEDs, on page 169](#) to ascertain the meaning of the LED colors.

### Useful Cisco IOS Commands - Line Cards

The **show module** command provides information that is useful in solving problems with ports on individual modules.

Some problems can be solved by resetting the line card. Power cycle the chassis - this resets, restarts, and power cycles the line card.

## Troubleshooting Supervisor Modules

This section only addresses problems with hardware. Problems with features or configuration are not covered here. Refer for your software configuration guide and release notes for information on configuring features or identifying known problems.

### Supervisor Module LEDs

- Check the LEDs on your supervisor and compare them to the described LED behaviors. See [Cisco Catalyst 9400 Series Supervisor Module LEDs, on page 170](#)
- The Supervisor Module STATUS LED turns either amber or red under the following conditions:
  - Power supply failure (not the same as removal of power supply)
  - Power supply fan failure
  - Removal or failure of fan tray
  - Mismatched power supplies in the chassis

### Standby Supervisor Engine Problems

- Switch# **show module**

If the standby supervisor module is not online or status indicates “other” or “faulty” in the output of the **show module** command or an amber status LED, create a console connection to the standby supervisor and check if it is in ROMMON mode or in continuous reboot. If the standby supervisor is in either of these two states, refer to the *System Management > Troubleshooting the Software Configuration* section of the Software Configuration Guide

- Make sure that the supervisor module properly seats in the backplane connector and that you have completely screwed down the captive screws for the supervisor module.
- Switch# **redundancy reload peer**

In order to determine whether the standby supervisor module is faulty, enter the **redundancy reload peer** command from the active supervisor and through the console to the standby supervisor. Observe the bootup sequence in order to identify any hardware failures. Currently, the active supervisor module cannot access the power-on diagnostics results of the standby supervisor module.

- Make sure that these configurations are synchronized between the active and redundant supervisor modules:
  - Startup configuration
  - Boot variable
  - Configuration register
  - Calendar
  - VLAN database

If a software upgrade is performed on both the active and standby supervisor module, verify that both supervisor modules are running the same new software image. If the software images are not the same, upgrade the software image. Use the procedure in the software configuration guide for your release.

If the standby supervisor still does not come on line, create a service request with Cisco Technical Support. Use the log of the switch output that you collected from the previous troubleshooting steps.

## Switch Self Reset

If the switch has reset or rebooted on its own, verify that the power source for the switch did not fail. If you use an uninterruptable power supply (UPS), make sure that the UPS does not have any problems.

The switch might have had a software crash. Enter the **more crashinfo:data** command to display the crash information including date and time of the last time that the switch crashed. To display the standby supervisor engine crash data, enter the **more slavecrashinfo:data** command. Crash data is not present if the switch has not crashed.

If the output indicates a software crash at the time that you suspect that the switch rebooted, the problem can be something other than a hardware failure. Contact Cisco Technical Support with the output of these commands:

- **show tech-support**
- **show logging**
- **more crashinfo:data**

## Cannot Connect to a Switch Through the Console Port

Make sure you are using the correct type of cable and that the cable pinouts are correct for your supervisor module

Make sure the terminal configuration matches the switch console port configuration—default console port settings are 9600 baud, 8 data bits, no parity, 1 stop bit.

To access the switch through the console port, the following must match

- The BAUD environment variable in the ROMMON

- Console port speed
- Start-up configuration



---

**Note** The factory default for the the BAUD environment variable is an explicit setting: BAUD variable=9600. This variable also defaults to 9600 (implicit setting) when a variable is not set explicitly.

---

During initial switch configuration, proceed as follows:

1. Ensure that the terminal configuration matches the switch console port speed configuration. The following example uses a Cisco switch as the console, and the console port number is 8. Enter the appropriate console port number when you configure the console port speed.

```
Switch# configure terminal
Enter configuration commands, one per line. End with CNTL/Z.
Switch(config)#line 8
Switch(config-line)# speed 9600
```

2. Access ROMMON prompt and verify the BAUD setting on the switch—Connect the console to system and while system is booting, after you see the the prompt, press CTRL+C to stop booting and access ROMMON prompt. In the example, the factory default setting is retained.

```
rommon 1> set
BAUD=9600
<output truncated>
```

If you want to change this setting, you can do so now

```
rommon 2> set BAUD <enter new speed>
```

If you enter a new speed, you must redo step 1 because you will lose ROMMON access immediately after setting a new speed.

3. Boot the image.

```
rommon 4> boot
```

During bootup, the BAUD rommon setting on the active supervisor is automatically synced to the standby.

4. Save the running configuration:

```
Switch# copy system:running-config nvram:startup-config
```

When the BAUD rommon variable is set in ROMMON mode, this value is extracted for the line console in the running configuration, when the system reloads. However, when the system parses the startup-configuration, the startup-configuration speed supercedes the value retrieved from BAUD. This step gets the BAUD and startup-config line console speed to match. A mismatch can cause loss of access to the console port.



---

**Note** Any time you manually change the BAUD speed in the ROMMON (explicitly **set** a new speed), you may lose console port access after a reload, or when switch boots, depending on what the BAUD speed and the console port speed is in the startup-configuration. The console port speed must be changed to match the new speed setting. After console access is restored, save the configuration to synchronize BAUD ROMMON speed, startup-configuration, and line console speed. Enter the **show bootvar** command to verify the new **BAUD variable** setting.

---

### Possible BAUD Mismatch—Scenario 1

Description—When you started off, the BAUD variable, start-up configuration and console port speed were all set to 115200. After this, if you unset the BAUD parameter at some point...

1. This is an implicit change in the BAUD variable to 9600 and not an explicit setting in the ROMMON. Further, the current console port session speed is still set to 115200 and you still have access.
2. Boot the image—Cisco IOS boots the image normally. The line console speed is initially retrieved from BAUD (9600), but Cisco IOS parses the startup-configuration, and the speed is changed to 115200. This matches the current console port speed.
3. Reload or power cycle the switch—Setup goes back to ROMMON mode and console access is lost because the default BAUD speed of 9600 is effective and mismatched with the console port speed. Set console port speed to 9600 to restore access.
4. Boot the image—Console port access is lost because the line console speed is initially retrieved from BAUD (9600), Cisco IOS parses the startup-configuration, where the speed is set to 115200 and not in sync with console port 9600 speed, and console port access is lost. Access is restored once console port speed is set to 115200.
5. Reload or power cycle the switch—Setup goes back to ROMMON mode, but console access is lost again due to mismatched BAUD of 9600.

In the above scenario, note the difference between an unset BAUD in step no.1 (where the implicit speed is 9600) and a set BAUD=9600 command (where the speed is explicitly set using the “set” command in ROMMON). You are able to access the console until step no.4 because the BAUD has an unset, implicit speed of 9600, but the speed was not actually changed from 115200. Once you reloaded or power cycled in step no.5, the speed was set to 9600.

Solution 1—If you save running configuration to start-up configuration (**copy system:running-config nvram:startup-config**) at step no. 2 then BAUD and the startup-configuration are synchronized with speeds at 115200, and subsequent reloads will not interrupt access.

Solution 2—(Instead of performing the above steps) Configure the line console speed to 9600, change the console port speed to 9600, and then save running configuration to start-up configuration, then BAUD in ROMMON and startup-configuration will be synchronized with speeds at 9600.

### Possible BAUD Mismatch—Scenario 2

Description—When you started off, the BAUD environment variable, startup-configuration speed and console port speed were all 9600. (The BAUD and startup configuration speeds have not been set explicitly). After this, at some point you explicitly set the BAUD variable to 115200...

1. You lose console access immediately. Set the console port speed to 115200 to restore access.
2. Boot the image—Line console speed is initially retrieved from BAUD (115200). While booting, the system parses the startup-configuration, but even though the configured speed is 9600, this is the value that the system defaults to, and the “speed 9600” line is not actually present in startup-configuration. Since the speed configuration is not present, it is not explicitly parsed and applied, so the speed retrieved from BAUD previously (115200) is used.

In this state, the line console speed is set to 115200, matching BAUD, while the startup-configuration has line console speed as default (9600). The system is useable since the speed was not changed to 9600, even with the BAUD and startup-configuration mismatch. If you save running configuration to start-up configuration, then BAUD and startup-config will be in sync with speeds explicitly set to 115200.

## Boot Problems

The supervisor module operates in a continuous loop by default if you have not set the boot variable `MANUAL_BOOT` in ROMMON mode. To boot manually, set `MANUAL_BOOT=yes`; to auto-boot, set `MANUAL_BOOT=no`.

The supervisor module goes into ROMMON mode or fails to boot when the system image is either corrupt or absent.

The supervisor module has an onboard system Flash memory (bootflash), which can easily hold multiple system images. Therefore, have a backup image. In addition to the bootflash, the supervisor module supports compact Flash in the `usbflash0:` device. The supervisor also provides for transfer via TFTP of the image from ROMMON mode, which enables faster recovery of absent or corrupt images.

In addition to the above mentioned storage devices, you can install a hard disk, which is displayed as `disk0:`. We recommend that you use this for general purpose file storage, similar to `usbflash0:`, but not to store system images.

## Finding the Serial Number

If you contact Cisco Technical Assistance Center (Cisco TAC), you should know the serial number of the part you are having a problem with. The following illustrations show where you can find the serial number on a chassis, supervisor module, line card, power supply module, and fan tray.

You can also use the **show version** command in privileged EXEC mode, to see the serial number.

**Figure 38: Chassis Serial Number Location**

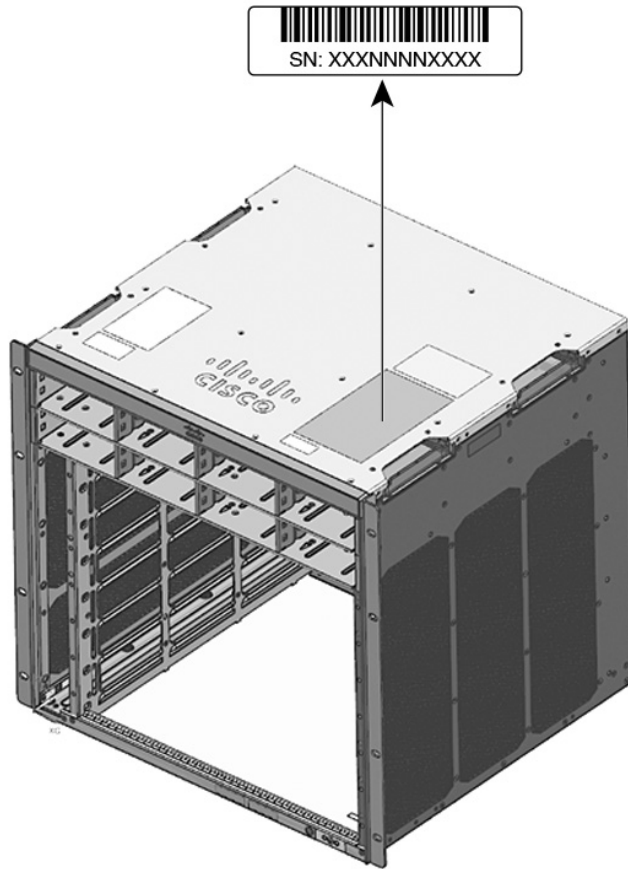

**Figure 39: Supervisor Module and Line Card Serial Number Location**

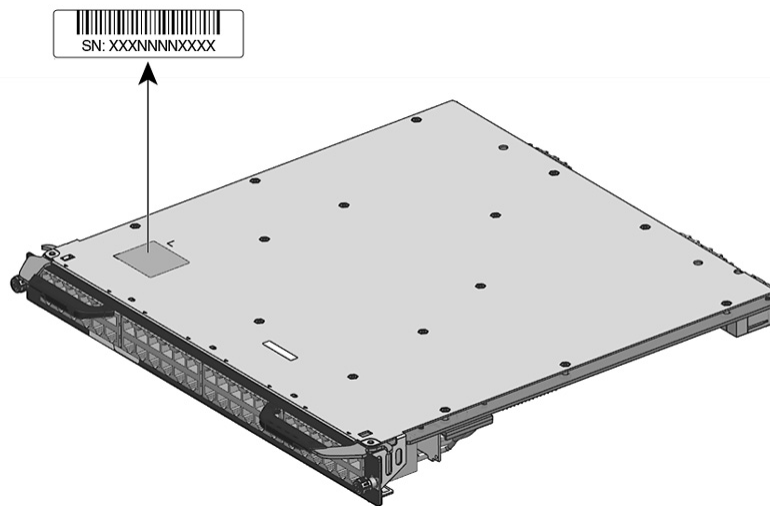

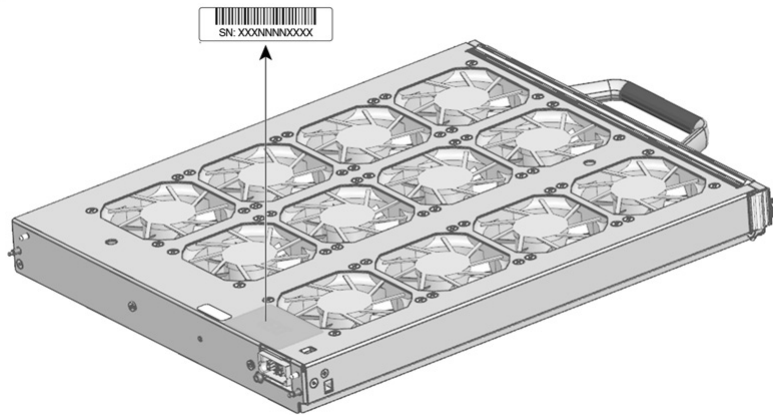
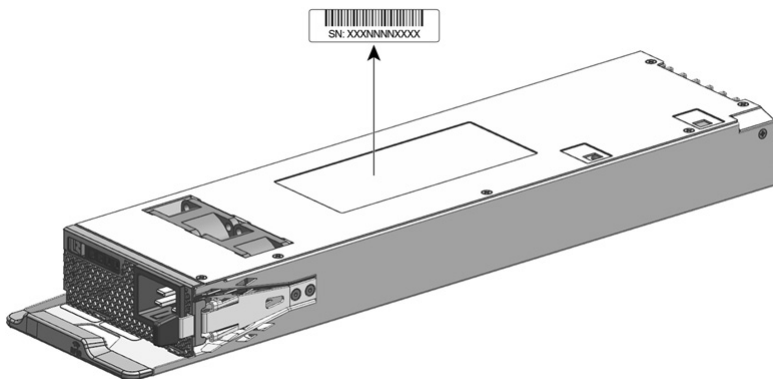
**Figure 40: Fan Tray Serial Number Location****Figure 41: Power Supply Module Serial Number Location**

## Contacting the Cisco Technical Assistance Center

If you are unable to solve a startup problem after using the troubleshooting suggestions in this chapter, contact a Cisco TAC representative for assistance and further instructions.

Before you call, have the following information ready to help the Cisco TAC assist you as quickly as possible:

- Date you received the switch
- Chassis serial number
- Type of software and release number
- Maintenance agreement or warranty information
- Brief description of the problem
- Console captures related to your problem
- Brief explanation of the steps you have already taken to isolate and resolve the problem





# CHAPTER 8

## Specifications

- [Chassis Specifications](#), on page 147
- [Power Supply Specifications](#), on page 153
- [Chassis and Module Power and Heat Values](#), on page 162
- [Weight Specifications](#), on page 163

## Chassis Specifications

### Catalyst 9404R Switch Chassis Specifications

**Table 9: Physical Specifications of the Chassis**

| Item                          | Specification                                          |
|-------------------------------|--------------------------------------------------------|
| Dimensions (H x W x D)        | 10.47 x 17.3 x 16.3 inches (26.53 x 43.94 x 41.40 cms) |
| Rack units (RU <sup>4</sup> ) | 6 RU                                                   |
| Weight                        | Chassis with fan tray—39.0 lbs (17.2 kgs)              |

<sup>4</sup> The chassis height is measured in rack units (RU or just U), where 1 RU or 1 U equals 1.75 in (44.45 mm).

**Table 10: Environmental Specifications of the Chassis**

| Item                                                                                | Specification                                                                                                                                                                                                                             |
|-------------------------------------------------------------------------------------|-------------------------------------------------------------------------------------------------------------------------------------------------------------------------------------------------------------------------------------------|
| Ambient temperature and altitude for normal operations <sup>5</sup>                 | <ul style="list-style-type: none"> <li>• 23° to 113°F (-5 to +45°C), up to 6,000 feet (1800 m)</li> <li>• 23° to 104°F (-5 to +40°C), up to 10,000 feet (3000 m)</li> </ul>                                                               |
| Ambient temperature and altitude for short-term <sup>6</sup> exceptional conditions | <ul style="list-style-type: none"> <li>• 23° to 131°F (-5 to +55°C), up to 6,000 feet (1800 m)</li> <li>• 23° to 122°F (-5 to +50°C), up to 10,000 feet (3000 m)</li> </ul> <p>Nonoperating and storage: -40° to 167°F (-40° to 75°C)</p> |

| Item                                                     | Specification                                                                                                                                                                                                                                                                                                                         |                                                                         |               |
|----------------------------------------------------------|---------------------------------------------------------------------------------------------------------------------------------------------------------------------------------------------------------------------------------------------------------------------------------------------------------------------------------------|-------------------------------------------------------------------------|---------------|
| Nonoperating and storage temperature                     | -40° to 167°F (-40° to 75°C)                                                                                                                                                                                                                                                                                                          |                                                                         |               |
| Thermal transition                                       | Hot to cold—at a maximum rate of 86°F (30°C) per hour<br>Cold to hot—at maximum rate of 204.8°F (96°C) per hour                                                                                                                                                                                                                       |                                                                         |               |
| Humidity (RH), ambient (noncondensing)                   | Operating, nonoperating and storage —10 to 95 percent                                                                                                                                                                                                                                                                                 |                                                                         |               |
| Altitude (operating and nonoperating)                    | -60 to 3000m                                                                                                                                                                                                                                                                                                                          |                                                                         |               |
| Sound pressure level (LpAD) and sound power level (LwAD) | LpAD—57 dBA<br>LwAD—no greater than 7.2 Bels<br>This is with four power supply modules installed and delivering 50 percent of rated output power; measured according to International Organization for Standardization (ISO) 7779 and declared according to ISO 9296.                                                                 |                                                                         |               |
| Airflow                                                  | <ul style="list-style-type: none"> <li>• Chassis (airflow direction when facing the front of the chassis) <ul style="list-style-type: none"> <li>• Standard Rack Mount (With or without shelf brackets)—Right to left</li> <li>• NEBS-Compliant Rack Mount—Front to back</li> </ul> </li> <li>• Power supply—Front to back</li> </ul> |                                                                         |               |
| Shock                                                    | Operating—5G 11ms (Half-sine)<br>Nonoperating and storage— 15G 11ms (Half-sine)                                                                                                                                                                                                                                                       |                                                                         |               |
| Sine Vibration                                           | <ul style="list-style-type: none"> <li>• Operating— 0.15G (10Hz-500Hz)</li> <li>• Nonoperating and storage— 0.8G (10Hz-500Hz)</li> </ul>                                                                                                                                                                                              |                                                                         |               |
| Random Vibration (Operating)                             | <b>Spectral Break Point Frequencies</b>                                                                                                                                                                                                                                                                                               | <b>Acceleration Spectral Density</b>                                    | <b>Slope</b>  |
|                                                          | 2.5 – 5 Hz                                                                                                                                                                                                                                                                                                                            | -                                                                       | 6 db /octave  |
|                                                          | 5 – 100 Hz                                                                                                                                                                                                                                                                                                                            | 0.1 [(m/s <sup>2</sup> ) <sup>2</sup> /Hz<br>(0.001 g <sup>2</sup> /Hz) | -             |
|                                                          | 100 – 200 Hz                                                                                                                                                                                                                                                                                                                          | -                                                                       | 24 db /octave |

| Item                                           | Specification                           |                                                                          |               |
|------------------------------------------------|-----------------------------------------|--------------------------------------------------------------------------|---------------|
| Random Vibration<br>(Nonoperating and Storage) | <b>Spectral Break Point Frequencies</b> | <b>Acceleration Spectral Density</b>                                     | <b>Slope</b>  |
|                                                | 2.5 – 5 Hz                              | -                                                                        | 6 db /octave  |
|                                                | 5 – 100 Hz                              | 1.0 [(m/s <sup>2</sup> ) <sup>2</sup> ]/Hz*<br>(0.01 g <sup>2</sup> /Hz) | -             |
|                                                | 100 – 200 Hz                            | -                                                                        | 24 db /octave |

<sup>5</sup> Minimum ambient temperature for cold startup is 0°C

<sup>6</sup> Short-term exceptional conditions are for no longer than a one-year period of—96 consecutive hours, or 360 hours total, or 15 occurrences.

## Catalyst 9407R Switch Chassis Specifications

**Table 11: Physical Specifications of the Chassis**

| Item                          | Specification                                            |
|-------------------------------|----------------------------------------------------------|
| Dimensions (H x W x D)        | 17.41 x 17.30 x 16.30 inches (44.22 x 43.94 x 41.40 cms) |
| Rack units (RU <sup>7</sup> ) | 10 RU                                                    |
| Weight                        | Chassis with fan tray—63.0 lb (28.58 kg)                 |

<sup>7</sup> The chassis height is measured in rack units (RU or just U), where 1 RU or 1 U equals 1.75 in (44.45 mm).

**Table 12: Environmental Specifications of the Chassis**

| Item                                                                                | Specification                                                                                                                                                                                                                             |
|-------------------------------------------------------------------------------------|-------------------------------------------------------------------------------------------------------------------------------------------------------------------------------------------------------------------------------------------|
| Ambient temperature and altitude for normal operations <sup>8</sup>                 | <ul style="list-style-type: none"> <li>• 23° to 113°F (-5 to +45°C), up to 6,000 feet (1800 m)</li> <li>• 23° to 104°F (-5 to +40°C), up to 10,000 feet (3000 m)</li> </ul>                                                               |
| Ambient temperature and altitude for short-term <sup>9</sup> exceptional conditions | <ul style="list-style-type: none"> <li>• 23° to 131°F (-5 to +55°C), up to 6,000 feet (1800 m)</li> <li>• 23° to 122°F (-5 to +50°C), up to 10,000 feet (3000 m)</li> </ul> <p>Nonoperating and storage: -40° to 167°F (-40° to 75°C)</p> |
| Nonoperating and storage temperature                                                | -40° to 167°F (-40° to 75°C)                                                                                                                                                                                                              |
| Thermal transition                                                                  | <p>Hot to cold—at a maximum rate of 86°F (30°C) per hour</p> <p>Cold to hot—at maximum rate of 204.8°F (96°C) per hour</p>                                                                                                                |
| Humidity (RH), ambient (noncondensing)                                              | Operating, nonoperating and storage —10 to 95 percent                                                                                                                                                                                     |

| Item                                                     | Specification                                                                                                                                                                                                                                                                                                                                       |                                                                       |               |
|----------------------------------------------------------|-----------------------------------------------------------------------------------------------------------------------------------------------------------------------------------------------------------------------------------------------------------------------------------------------------------------------------------------------------|-----------------------------------------------------------------------|---------------|
| Altitude (operating and nonoperating)                    | -60 to 3000m                                                                                                                                                                                                                                                                                                                                        |                                                                       |               |
| Sound pressure level (LpAD) and sound power level (LwAD) | LpAD—58 dBA<br>LwAD—no greater than 7.7 Bels<br>This is with eight power supply modules installed and delivering 50 percent of rated output power; measured according to International Organization for Standardization (ISO) 7779 and declared according to ISO 9296.                                                                              |                                                                       |               |
| Airflow                                                  | <ul style="list-style-type: none"> <li>• Chassis (airflow direction when facing the front of the chassis)               <ul style="list-style-type: none"> <li>• Standard Rack Mount (With or without shelf brackets)—Right to left</li> <li>• NEBS-Compliant Rack Mount—Front to back</li> </ul> </li> <li>• Power supply—Front to back</li> </ul> |                                                                       |               |
| Shock                                                    | Operating—5G 11ms (Half-sine)<br>Nonoperating and storage— 15G 11ms (Half-sine)                                                                                                                                                                                                                                                                     |                                                                       |               |
| Sine Vibration                                           | <ul style="list-style-type: none"> <li>• Operating— 0.15G (10Hz-500Hz)</li> <li>• Nonoperating and storage— 0.8G (10Hz-500Hz)</li> </ul>                                                                                                                                                                                                            |                                                                       |               |
| Random Vibration (Operating)                             | <b>Spectral Break Point Frequencies</b>                                                                                                                                                                                                                                                                                                             | <b>Acceleration Spectral Density</b>                                  | <b>Slope</b>  |
|                                                          | 2.5 – 5 Hz                                                                                                                                                                                                                                                                                                                                          | -                                                                     | 6 db /octave  |
|                                                          | 5 – 100 Hz                                                                                                                                                                                                                                                                                                                                          | 0.1 [(m/s <sup>2</sup> ) <sup>2</sup> ]/Hz (0.001 g <sup>2</sup> /Hz) | -             |
|                                                          | 100 – 200 Hz                                                                                                                                                                                                                                                                                                                                        | -                                                                     | 24 db /octave |

| Item                                        | Specification                           |                                                        |               |
|---------------------------------------------|-----------------------------------------|--------------------------------------------------------|---------------|
| Random Vibration (Nonoperating and Storage) | <b>Spectral Break Point Frequencies</b> | <b>Acceleration Spectral Density</b>                   | <b>Slope</b>  |
|                                             | 2.5 – 5 Hz                              | -                                                      | 6 db /octave  |
|                                             | 5 – 100 Hz                              | 1.0 [(m/s <sup>2</sup> )/Hz* (0.01 g <sup>2</sup> /Hz) | -             |
|                                             | 100 – 200 Hz                            | -                                                      | 24 db /octave |

<sup>8</sup> Minimum ambient temperature for cold startup is 0°C

<sup>9</sup> Short-term exceptional conditions are for no longer than a one-year period of—96 consecutive hours, or 360 hours total, or 15 occurrences.

## Catalyst 9410R Switch Chassis Specifications

**Table 13: Physical Specifications of the Chassis**

| Item                           | Specification                                        |
|--------------------------------|------------------------------------------------------|
| Dimensions (H x W x D)         | 22.61 x 17.30 x 16.30 in. (57.43 x 43.94 x 41.40 cm) |
| Rack units (RU <sup>10</sup> ) | 13 RU                                                |
| Weight                         | Chassis with fan tray—65.0 lb (29.48 kg)             |

<sup>10</sup> The chassis height is measured in rack units (RU or just U), where 1 RU or 1 U equals 1.75 in (44.45 mm).

**Table 14: Environmental Specifications of the Chassis**

| Item                                                                                            | Specification                                                                                                                                                               |
|-------------------------------------------------------------------------------------------------|-----------------------------------------------------------------------------------------------------------------------------------------------------------------------------|
| Ambient temperature and altitude for normal operations <sup>11</sup>                            | <ul style="list-style-type: none"> <li>• 23° to 113°F (-5 to +45°C), up to 6,000 feet (1800 m)</li> <li>• 23° to 104°F (-5 to +40°C), up to 10,000 feet (3000 m)</li> </ul> |
| Ambient temperature and altitude for short-term conditions <sup>12</sup> exceptional conditions | <ul style="list-style-type: none"> <li>• 23° to 131°F (-5 to +55°C), up to 6,000 feet (1800 m)</li> <li>• 23° to 122°F (-5 to +50°C), up to 10,000 feet (3000 m)</li> </ul> |
| Nonoperating and storage                                                                        | -40° to 167°F (-40° to 75°C)                                                                                                                                                |

| Item                                                     | Specification                                                                                                                                                                                                                                                                                                                                                                                                        |                                                                        |                               |       |            |   |              |            |                                                                        |   |              |   |                |
|----------------------------------------------------------|----------------------------------------------------------------------------------------------------------------------------------------------------------------------------------------------------------------------------------------------------------------------------------------------------------------------------------------------------------------------------------------------------------------------|------------------------------------------------------------------------|-------------------------------|-------|------------|---|--------------|------------|------------------------------------------------------------------------|---|--------------|---|----------------|
| Thermal transition                                       | Hot to cold—at a maximum rate of 86°F (30°C) per hour<br>Cold to hot—at maximum rate of 204.8°F (96°C) per hour                                                                                                                                                                                                                                                                                                      |                                                                        |                               |       |            |   |              |            |                                                                        |   |              |   |                |
| Humidity (RH), ambient (noncondensing)                   | Operating, nonoperating and storage —10 to 95 percent                                                                                                                                                                                                                                                                                                                                                                |                                                                        |                               |       |            |   |              |            |                                                                        |   |              |   |                |
| Altitude (operating and nonoperating)                    | -60 to 3000m                                                                                                                                                                                                                                                                                                                                                                                                         |                                                                        |                               |       |            |   |              |            |                                                                        |   |              |   |                |
| Sound pressure level (LpAD) and sound power level (LwAD) | LpAD—60 dBA<br>LwAD—no greater than 7.8 Bels<br><br>This is with eight power supply modules installed and delivering 50 percent of rated output power; measured according to International Organization for Standardization (ISO) 7779 and declared according to ISO 9296.                                                                                                                                           |                                                                        |                               |       |            |   |              |            |                                                                        |   |              |   |                |
| Airflow                                                  | <ul style="list-style-type: none"> <li>• Chassis (airflow direction when facing the front of the chassis) <ul style="list-style-type: none"> <li>• Standard Rack Mount (With or without shelf brackets)—Right to left</li> <li>• NEBS-Compliant Rack Mount—Front to back</li> </ul> </li> <li>• Power supply—Front to back</li> </ul>                                                                                |                                                                        |                               |       |            |   |              |            |                                                                        |   |              |   |                |
| Shock                                                    | Operating—5G 11ms (Half-sine)<br>Nonoperating and storage— 15G 11ms (Half-sine)                                                                                                                                                                                                                                                                                                                                      |                                                                        |                               |       |            |   |              |            |                                                                        |   |              |   |                |
| Sine Vibration                                           | <ul style="list-style-type: none"> <li>• Operating— 0.15G (10Hz-500Hz)</li> <li>• Nonoperating and storage— 0.8G (10Hz-500Hz)</li> </ul>                                                                                                                                                                                                                                                                             |                                                                        |                               |       |            |   |              |            |                                                                        |   |              |   |                |
| Random Vibration (Operating)                             | <table border="1"> <thead> <tr> <th>Spectral Break Point</th> <th>Acceleration Spectral Density</th> <th>Slope</th> </tr> </thead> <tbody> <tr> <td>2.5 – 5 Hz</td> <td>-</td> <td>6 db /octave</td> </tr> <tr> <td>5 – 100 Hz</td> <td>0 . 1 [(m/s<sup>2</sup>)<sup>2</sup>/Hz (0.001 g<sup>2</sup>/Hz)</td> <td>-</td> </tr> <tr> <td>100 – 200 Hz</td> <td>-</td> <td>2 4 db /octave</td> </tr> </tbody> </table> | Spectral Break Point                                                   | Acceleration Spectral Density | Slope | 2.5 – 5 Hz | - | 6 db /octave | 5 – 100 Hz | 0 . 1 [(m/s <sup>2</sup> ) <sup>2</sup> /Hz (0.001 g <sup>2</sup> /Hz) | - | 100 – 200 Hz | - | 2 4 db /octave |
|                                                          | Spectral Break Point                                                                                                                                                                                                                                                                                                                                                                                                 | Acceleration Spectral Density                                          | Slope                         |       |            |   |              |            |                                                                        |   |              |   |                |
|                                                          | 2.5 – 5 Hz                                                                                                                                                                                                                                                                                                                                                                                                           | -                                                                      | 6 db /octave                  |       |            |   |              |            |                                                                        |   |              |   |                |
|                                                          | 5 – 100 Hz                                                                                                                                                                                                                                                                                                                                                                                                           | 0 . 1 [(m/s <sup>2</sup> ) <sup>2</sup> /Hz (0.001 g <sup>2</sup> /Hz) | -                             |       |            |   |              |            |                                                                        |   |              |   |                |
| 100 – 200 Hz                                             | -                                                                                                                                                                                                                                                                                                                                                                                                                    | 2 4 db /octave                                                         |                               |       |            |   |              |            |                                                                        |   |              |   |                |
|                                                          |                                                                                                                                                                                                                                                                                                                                                                                                                      |                                                                        |                               |       |            |   |              |            |                                                                        |   |              |   |                |
|                                                          |                                                                                                                                                                                                                                                                                                                                                                                                                      |                                                                        |                               |       |            |   |              |            |                                                                        |   |              |   |                |
|                                                          |                                                                                                                                                                                                                                                                                                                                                                                                                      |                                                                        |                               |       |            |   |              |            |                                                                        |   |              |   |                |

| Item                                        | Specification               |                                                                      |              |  |
|---------------------------------------------|-----------------------------|----------------------------------------------------------------------|--------------|--|
| Random Vibration (Nonoperating and Storage) | <b>Spectral Break Point</b> | <b>Acceleration Spectral Density</b>                                 | <b>Slope</b> |  |
|                                             | 2.5 – 5 Hz                  | -                                                                    | 6 dB/octave  |  |
|                                             | 5 – 100 Hz                  | 1.0 [(m/s <sup>2</sup> ) <sup>2</sup> /Hz* (0.01 g <sup>2</sup> /Hz) | -            |  |
|                                             | 100 – 200 Hz                | -                                                                    | 24 dB/octave |  |

<sup>11</sup> Minimum ambient temperature for cold startup is 0°C

<sup>12</sup> Short-term exceptional conditions are for no longer than a one-year period of—96 consecutive hours, or 360 hours total, or 15 occurrences.

## Power Supply Specifications

### 2100-W AC-Input Power Supply Specifications

The following table lists specifications for the 2100 W AC input power supply:

**Table 15: 2100-W AC-Input Power Supply Specifications**

| Specification      | Description                                                                                                                                                                                                                                                                                                                                                                                                                                                         |
|--------------------|---------------------------------------------------------------------------------------------------------------------------------------------------------------------------------------------------------------------------------------------------------------------------------------------------------------------------------------------------------------------------------------------------------------------------------------------------------------------|
| AC-input type      | Wide-ranging input with power factor correction.<br><br><b>Note</b> Power factor correction is a standard feature on AC-input power supplies. Power factor correction reduces the reactive component in the source AC current, allowing higher power factors (0.90 minimum at loads equal to or greater than 20 percent of maximum loads, and 0.95 minimum at 2100W maximum loads, at 115/230 VAC nominal AC input voltages) and lower harmonic current components. |
| AC-input voltage   | Low-line (115 VAC nominal)—85 VAC (min) to 132 VAC (max)<br>High-line (230 VAC nominal)—180 VAC (min) to 264 VAC (max)                                                                                                                                                                                                                                                                                                                                              |
| AC-input current   | 11.44 A at 100 VAC (950 W output)<br>11.44 A at 200 VAC (2112 W output)                                                                                                                                                                                                                                                                                                                                                                                             |
| AC-input frequency | 50/60Hz nominal (47 to 63Hz full range)                                                                                                                                                                                                                                                                                                                                                                                                                             |

| Specification                                     | Description                                                                                                                                                                                                                                                                                                                                                                                                                                                                                                                                                                                                                                                                                                                                                                                                                  |
|---------------------------------------------------|------------------------------------------------------------------------------------------------------------------------------------------------------------------------------------------------------------------------------------------------------------------------------------------------------------------------------------------------------------------------------------------------------------------------------------------------------------------------------------------------------------------------------------------------------------------------------------------------------------------------------------------------------------------------------------------------------------------------------------------------------------------------------------------------------------------------------|
| Branch circuit requirement                        | Each chassis power supply should have its own dedicated, fused-branch circuit: <ul style="list-style-type: none"> <li>• North America—15 A.</li> <li>• International—Circuits sized to local and national codes.</li> <li>• All AC power supply inputs are fully isolated. <ul style="list-style-type: none"> <li>• Source AC can be out of phase between multiple power supplies in the same chassis, which means that PS1 can be operating from phase A and PS2 can be operating from phase B.</li> <li>• For high-line operation, the power supply operates with the line conductor wired to an source AC phase, and the Neutral conductor wired either to a Neutral, single-phase power system, or to another source AC phase as long as the net input voltage is in the range of 180 to 264 VAC.</li> </ul> </li> </ul> |
| Power supply output capacity                      | For 55 VDC output – 940W at 115 VAC; 2102W at 230 VAC<br>For 3.3VDC output – 10W at 115 VAC; 10 W at 230 VAC                                                                                                                                                                                                                                                                                                                                                                                                                                                                                                                                                                                                                                                                                                                 |
| Power supply output                               | <ul style="list-style-type: none"> <li>• 100 to 120 VAC operation <ul style="list-style-type: none"> <li>• 3.0A @ 3.3 V</li> <li>• 17.09A @ 55V</li> </ul> </li> <li>• 200 to 240 VAC operation <ul style="list-style-type: none"> <li>• 3.0A @ 3.3 V</li> <li>• 38.21A @ 55V</li> </ul> </li> </ul>                                                                                                                                                                                                                                                                                                                                                                                                                                                                                                                         |
| Output holdup time                                | 20 ms minimum.                                                                                                                                                                                                                                                                                                                                                                                                                                                                                                                                                                                                                                                                                                                                                                                                               |
| kVA rating <sup>13</sup>                          | 2112W (total output power) or 2246.8 kVA (high-line operation)                                                                                                                                                                                                                                                                                                                                                                                                                                                                                                                                                                                                                                                                                                                                                               |
| Heat dissipation (in British Thermal Units (BTU)) | For 2112W—460.0 BTU per hour<br>For 950W—244.0 BTU per hour                                                                                                                                                                                                                                                                                                                                                                                                                                                                                                                                                                                                                                                                                                                                                                  |
| Weight                                            | 5.0 lb (2.3 kg)                                                                                                                                                                                                                                                                                                                                                                                                                                                                                                                                                                                                                                                                                                                                                                                                              |

<sup>13</sup> The kVA rating listed for the power supply should be used as the sizing criteria for both UPS outputs as well as standard circuits and transformers to power a switch

## 2100-W Power Supply Module AC Power Cords

The following table lists the specifications for the AC power cords that are available for the 2100 W AC-input power supply. The table also includes references to power cord illustrations.





**Note** All 2100 W power supply power cord:







- Lengths range from 9.84 – 14 feet (3.0 – 4.293 meters); with most cord lengths between 13 and 14 feet (4.013 and 4.293 meters)
- Have an IEC60320/C19 appliance connector at one end.

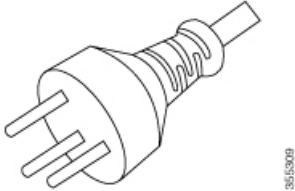

**Figure 42: IEC60320/C19 Appliance Connector**

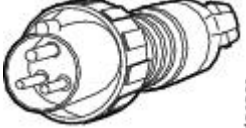

**Table 16: 2100 W Power Supply AC Power Cords**

| Locale        | Part Number       | Cordset Rating | AC Source Plug Type                                                        |
|---------------|-------------------|----------------|----------------------------------------------------------------------------|
| Argentina     | CAB-I309-C19-INTL | 20 A, 250 VAC  | <p><b>Figure 43: CAB-I309-C19-INTL= (Argentina)</b></p>                    |
| Australia     | CAB-AC-16A-AUS    | 16 A, 250 VAC  | <p><b>Figure 44: CAB-AC-16A-AUS= (Australia)</b></p>                       |
| Europe        | CAB-CEE77-C19-EU  | 16 A, 250 VAC  | <p><b>Figure 45: CAB-CEE77-C19-EU= and CAB-I309-C19-INTL= (Europe)</b></p> |
|               | CAB-I309-C19-INTL | 20 A, 250 VAC  |                                                                            |
| India         | CAB-SABS-C19-IND  | 16 A, 250 VAC  | <p><b>Figure 46: CAB-SABS-C19-IND= (India)</b></p>                         |
| International | CAB-I309-C19-INTL | 20 A, 250 VAC  | <p><b>Figure 47: CAB-I309-C19-INTL= (International)</b></p>                |

| Locale                                                                   | Part Number       | Cordset Rating | AC Source Plug Type                                                                                                                                                |
|--------------------------------------------------------------------------|-------------------|----------------|--------------------------------------------------------------------------------------------------------------------------------------------------------------------|
| Israel                                                                   | CAB-S132-C19-ISRL | 16 A, 250 VAC  | <p><b>Figure 48: CAB-S132-C19-ISRL= (Israel)</b></p>                             |
| Italy                                                                    | CAB-C2316-C19-IT  | 16 A, 250 VAC  | <p><b>Figure 49: CAB-C2316-C19-IT= (Italy)</b></p>                               |
| Japan, North America<br>(Nonlocking Plug)<br>200 to 240 VAC<br>Operation | CAB-US620P-C19-US | 20 A, 250 VAC  | <p><b>Figure 50: CAB-US620P-C19-US= (Japan, North America - Nonlocking)</b></p>  |
| Japan, North America<br>(Locking Plug) 200 to<br>240 VAC Operation       | CAB-L620P-C19-US  | 20 A, 250 VAC  | <p><b>Figure 51: CAB-L620P-C19-US= ( Japan, North America - Locking )</b></p>   |
| North America                                                            | CAB-US515P-C19-US | 125VAC, 15A    | <p><b>Figure 52: CAB-US515P-C19-US=(North America)</b></p>                      |
| North America                                                            | CAB-US520-C19-US  | 20 A, 125 VAC  | <p><b>Figure 53: CAB-US520-C19-US= (North America)</b></p>                     |
| South Africa                                                             | CAB-I309-C19-INTL | 20 A, 250 VAC  | <p><b>Figure 54: CAB-I309-C19-INTL= (South Africa)</b></p>                     |

| Locale         | Part Number       | Cordset Rating | AC Source Plug Type                                                                                                                 |
|----------------|-------------------|----------------|-------------------------------------------------------------------------------------------------------------------------------------|
| United Kingdom | CAB-BS1363-C19-UK | 250 VAC, 13 A  | Figure 55: CAB-BS1363-C19-UK=(United Kingdom)<br> |
|                | CAB-I309-C19-INTL | 20 A, 250 VAC  | Figure 56: CAB-I309-C19-INTL=(International)<br>  |
| UPS 220V       | CAB-C19-CBN       | 20 A, 250 VAC  | Figure 57: 130923<br>                             |

## 3200-W AC-Input Power Supply Specifications

The following table lists specifications for the 3200 W AC input power supply:

**Table 17: 3200 W AC-Input Power Supply Specifications**

| Specification      | Description                                                                                                                                                                                                                                                                                                                                                                                                                                                         |
|--------------------|---------------------------------------------------------------------------------------------------------------------------------------------------------------------------------------------------------------------------------------------------------------------------------------------------------------------------------------------------------------------------------------------------------------------------------------------------------------------|
| AC-input type      | Wide-ranging input with power factor correction.<br><br><b>Note</b> Power factor correction is a standard feature on AC-input power supplies. Power factor correction reduces the reactive component in the source AC current, allowing higher power factors (0.90 minimum at loads equal to or greater than 20 percent of maximum loads, and 0.95 minimum at 3200W maximum loads, at 115/230 VAC nominal AC input voltages) and lower harmonic current components. |
| AC-input voltage   | Low-line (115 VAC nominal)—85 VAC (min) to 132 VAC (max)<br>High-line (230 VAC nominal)—180 VAC (min) to 264 VAC (max)                                                                                                                                                                                                                                                                                                                                              |
| AC-input current   | 17.6 A at 100 VAC (1570 W output)<br>17.6 A at 200 VAC (3200 W output)                                                                                                                                                                                                                                                                                                                                                                                              |
| AC-input frequency | 50/60Hz nominal (47 to 63Hz full range)                                                                                                                                                                                                                                                                                                                                                                                                                             |

| Specification                                     | Description                                                                                                                                                                                                                                                                                                                                                                                                                                                                                                                                                                                                                                                                                                                                                                                                                         |
|---------------------------------------------------|-------------------------------------------------------------------------------------------------------------------------------------------------------------------------------------------------------------------------------------------------------------------------------------------------------------------------------------------------------------------------------------------------------------------------------------------------------------------------------------------------------------------------------------------------------------------------------------------------------------------------------------------------------------------------------------------------------------------------------------------------------------------------------------------------------------------------------------|
| Branch circuit requirement                        | <p>Each chassis power supply should have its own dedicated, fused-branch circuit:</p> <ul style="list-style-type: none"> <li>• North America—20 A.</li> <li>• International—Circuits sized to local and national codes.</li> <li>• All AC power supply inputs are fully isolated. <ul style="list-style-type: none"> <li>• Source AC can be out of phase between multiple power supplies in the same chassis, which means that PS1 can be operating from phase A and PS2 can be operating from phase B.</li> </ul> </li> <li>• For high-line operation, the power supply operates with the line conductor wired to an source AC phase, and the Neutral conductor wired either to a Neutral, single-phase power system, or to another source AC phase as long as the net input voltage is in the range of 180 to 264 VAC.</li> </ul> |
| Power supply output capacity                      | <p>For 55 VDC output—1560 W at 115 VAC; 3190 W at 230 VAC</p> <p>For 3.3VDC output—10 W at 115 VAC; 10 W at 230 VAC</p>                                                                                                                                                                                                                                                                                                                                                                                                                                                                                                                                                                                                                                                                                                             |
| Power supply output                               | <ul style="list-style-type: none"> <li>• 100 to 120 VAC operation <ul style="list-style-type: none"> <li>• 3.0A @ 3.3 V</li> <li>• 28.36 A @ 55V</li> </ul> </li> <li>• 200 to 240 VAC operation <ul style="list-style-type: none"> <li>• 3.0A @ 3.3 V</li> <li>• 58 A @ 55V</li> </ul> </li> </ul>                                                                                                                                                                                                                                                                                                                                                                                                                                                                                                                                 |
| Output holdup time                                | 20 ms minimum.                                                                                                                                                                                                                                                                                                                                                                                                                                                                                                                                                                                                                                                                                                                                                                                                                      |
| kVA rating <sup>14</sup>                          | 3200W (total output power ) or 3478.3 kVA (high-line operation).                                                                                                                                                                                                                                                                                                                                                                                                                                                                                                                                                                                                                                                                                                                                                                    |
| Heat dissipation (in British Thermal Units (BTU)) | <p>For 3200W—948.86 BTU per hour</p> <p>For 1570W—594.85 BTU per hour</p>                                                                                                                                                                                                                                                                                                                                                                                                                                                                                                                                                                                                                                                                                                                                                           |
| Weight                                            | 5.0 lb (2.3 kg)                                                                                                                                                                                                                                                                                                                                                                                                                                                                                                                                                                                                                                                                                                                                                                                                                     |

<sup>14</sup> The kVA rating listed for the power supply should be used as the sizing criteria for both UPS outputs as well as standard circuits and transformers to power a switch

## 3200-W Power Supply Module AC Power Cords

The following table lists the specifications for the AC power cords that are available for the 3000 W AC-input power supply. The table also includes references to power cord illustrations.



**Note** All 3200 W power supply power cord:







- Lengths range from 9.84 – 14 feet (3.0 – 4.293 meters); with most cord lengths between 13 and 14 feet (4.013 and 4.293 meters)
- Have an IEC60320/C19 appliance connector at one end.

**Figure 58: IEC60320/C19 Appliance Connector**

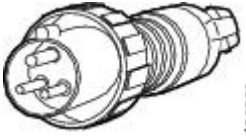
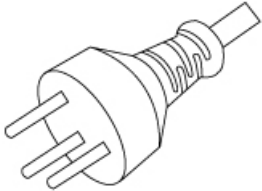

**Table 18: 3200 W Power Supply AC Power Cords**

| Locale    | Part Number       | Cordset Rating | AC Source Plug Type                                                        |
|-----------|-------------------|----------------|----------------------------------------------------------------------------|
| Argentina | CAB-I309-C19-INTL | 20 A, 250 VAC  | <p><b>Figure 59: CAB-I309-C19-INTL= (Argentina)</b></p>                    |
| Australia | CAB-AC-16A-AUS    | 16 A, 250 VAC  | <p><b>Figure 60: CAB-AC-16A-AUS= (Australia)</b></p>                       |
| China     | CAB-9K16A-CH      | 16 A, 250 VAC  | <p><b>Figure 61: CAB-9K16A-CH= (China)</b></p>                             |
| Europe    | CAB-CEE77-C19-EU  | 16 A, 250 VAC  | <p><b>Figure 62: CAB-CEE77-C19-EU= and CAB-I309-C19-INTL= (Europe)</b></p> |
|           | CAB-I309-C19-INTL | 20 A, 250 VAC  |                                                                            |
| India     | CAB-SABS-C19-IND  | 16 A, 250 VAC  | <p><b>Figure 63: CAB-SABS-C19-IND= (India)</b></p>                         |

| Locale                                                                   | Part Number       | Cordset Rating | AC Source Plug Type                                                                                                                                                                |
|--------------------------------------------------------------------------|-------------------|----------------|------------------------------------------------------------------------------------------------------------------------------------------------------------------------------------|
| International                                                            | CAB-I309-C19-INTL | 20 A, 250 VAC  | <p><b>Figure 64: CAB-I309-C19-INTL= (International)</b></p>  <p>1200360</p>                      |
| Israel                                                                   | CAB-S132-C19-ISRL | 16 A, 250 VAC  | <p><b>Figure 65: CAB-S132-C19-ISRL= (Israel)</b></p>  <p>3515309</p>                             |
| Italy                                                                    | CAB-C2316-C19-IT  | 16 A, 250 VAC  | <p><b>Figure 66: CAB-C2316-C19-IT= (Italy)</b></p>  <p>1200338</p>                                |
| Japan, North America<br>(Nonlocking Plug)<br>200 to 240 VAC<br>Operation | CAB-US620P-C19-US | 20 A, 250 VAC  | <p><b>Figure 67: CAB-US620P-C19-US= (Japan, North America - Nonlocking)</b></p>  <p>1303315</p> |
| Japan, North America<br>(Locking Plug) 200 to<br>240 VAC Operation       | CAB-L620P-C19-US  | 20 A, 250 VAC  | <p><b>Figure 68: CAB-L620P-C19-US= ( Japan, North America - Locking )</b></p>  <p>1303361</p>   |
| North America                                                            | CAB-US520-C19-US  | 20 A, 125 VAC  | <p><b>Figure 69: CAB-US520-C19-US= (North America)</b></p>  <p>1303362</p>                      |
| South Africa                                                             | CAB-I309-C19-INTL | 20 A, 250 VAC  | <p><b>Figure 70: CAB-I309-C19-INTL= (South Africa)</b></p>  <p>1200360</p>                     |

| Locale   | Part Number | Cordset Rating | AC Source Plug Type                                                                                         |
|----------|-------------|----------------|-------------------------------------------------------------------------------------------------------------|
| UPS 220V | CAB-C19-CBN | 20 A, 250 VAC  | <p>Figure 71: 130923</p>  |

## 3200-W DC-Input Power Supply Specifications

The following table lists the specifications for a 3200-W DC-input power supply module:

**Table 19: 3200-W DC-Input Power Supply Specifications**

| Specification                                     | Description                                                                                                                                                                                                                                                                                                                                                                                              |
|---------------------------------------------------|----------------------------------------------------------------------------------------------------------------------------------------------------------------------------------------------------------------------------------------------------------------------------------------------------------------------------------------------------------------------------------------------------------|
| DC-input voltage                                  | -40 to -72 VDC, with extended range of up to -75 VDC                                                                                                                                                                                                                                                                                                                                                     |
| DC-input current                                  | Nominal: 36 A per DC input (72 A total) at -48 to -60 VDC input<br>Maximum: 44 A per DC input at -40 VDC input                                                                                                                                                                                                                                                                                           |
| Power supply output capacity                      | For 55 VDC output—3190 W<br>For 3.3VDC output—10 W                                                                                                                                                                                                                                                                                                                                                       |
| Output holdup time                                | 8 ms                                                                                                                                                                                                                                                                                                                                                                                                     |
| Temperature                                       | <ul style="list-style-type: none"> <li>Steady State Operating: <ul style="list-style-type: none"> <li>-5 to +55 °C (45 °C at 13,123 feet) full load and -40 to -75 VDC</li> <li>-5 to +60 °C (50 °C at 13,123 feet) half load and -40 to -75 VDC</li> </ul> </li> <li>Nonoperating: -40 to +85 °C</li> </ul>                                                                                             |
| Humidity                                          | <ul style="list-style-type: none"> <li>Operating: 10 to 90 percent, noncondensing</li> <li>Nonoperating: 5 to 95 percent, noncondensing</li> </ul>                                                                                                                                                                                                                                                       |
| Thermal Shock                                     | <ul style="list-style-type: none"> <li>Operating: -5 to +55 °C at 2.5 °C per minute</li> <li>Nonoperating: -25 to +70 °C with a changeover time of three minutes</li> </ul>                                                                                                                                                                                                                              |
| Altitude                                          | <ul style="list-style-type: none"> <li>Operating: -500 to 13,123 feet over allowable temperature range (-5 to +55 °C) and full load, derating 1.4 °C per 1000 feet above 6,000 feet</li> </ul> <p><b>Note</b> The operating altitude in China is 6,561.6 ft. (2000 m) maximum</p> <ul style="list-style-type: none"> <li>Nonoperating: -1,000 to 50,000 feet over allowable temperature range</li> </ul> |
| Heat dissipation (in British Thermal Units [BTU]) | For 3200W—950 BTU per hour                                                                                                                                                                                                                                                                                                                                                                               |

| Specification | Description      |
|---------------|------------------|
| Weight        | 6.61 lb (3.0 kg) |

## Chassis and Module Power and Heat Values

The following tables provide the power and heat dissipation data. Unless otherwise noted, the information in the tables is measured under fully loaded conditions (transceivers installed).



**Note** DC output power is the output from the power supply (internal to the system). The AC-input power is the input from the outlet to the power supply. The percentage difference between the two values is the efficiency of the power supply.

**Table 20: Power Requirements and Heat Dissipation - Fan Tray**

| PID       | AC-Input Power in Watts<br>(Power Allocated) | DC-Output in Watts<br>(Power Requested) | Current @ 90V | Current @ 120V | Current @ 180V | Current @ 240V | Heat Diss. in BTU / hr. |
|-----------|----------------------------------------------|-----------------------------------------|---------------|----------------|----------------|----------------|-------------------------|
| C9404-FAN | 411                                          | 370                                     | 4.57          | 3.43           | 2.28           | 1.71           | 1403                    |
| C9407-FAN | 600                                          | 540                                     | 6.67          | 5.00           | 3.33           | 2.50           | 2047                    |
| C9410-FAN | 778                                          | 700                                     | 8.64          | 6.48           | 4.32           | 3.24           | 2654                    |

**Table 21: Power Requirements and Heat Dissipation - Supervisor Modules**

| PID             | AC-Input Power in Watts<br>(Power Allocated) | DC-Output in Watts<br>(Power Requested) | Current @ 90V | Current @ 120V | Current @ 180V | Current @ 240V | Heat Diss. in BTU / hr. |
|-----------------|----------------------------------------------|-----------------------------------------|---------------|----------------|----------------|----------------|-------------------------|
| C9400-SUP-1     | 444                                          | 400                                     | 4.94          | 3.70           | 2.47           | 1.85           | 1516                    |
| C9400-SUP-1XL   | 444                                          | 400                                     | 4.94          | 3.70           | 2.47           | 1.85           | 1516                    |
| C9400-SUP-1XL-Y | 444                                          | 400                                     | 4.94          | 3.70           | 2.47           | 1.85           | 1516                    |
| C9400X-SUP-2    | 722                                          | 650                                     | 8.02          | 6.02           | 4.01           | 3.01           | 2464                    |
| C9400X-SUP-2XL  | 722                                          | 650                                     | 8.02          | 6.02           | 4.01           | 3.01           | 2464                    |



Table 22: Power Requirements and Heat Dissipation— Line Cards

| PID           | AC-Input Power in Watts<br>(Power Allocated) | DC-Output in Watts<br>(Power Requested) | Current @ 90V | Current @ 120V | Current @ 180V | Current @ 240V | Heat Diss. in BTU / hr. |
|---------------|----------------------------------------------|-----------------------------------------|---------------|----------------|----------------|----------------|-------------------------|
| C9400-LC-12QC | 222                                          | 200                                     | 2.47          | 1.85           | 1.23           | 0.93           | 758                     |
| C9400-LC-24S  | 133                                          | 120                                     | 1.48          | 1.11           | 0.74           | 0.56           | 455                     |
| C9400-LC-24XS | 222                                          | 200                                     | 2.47          | 1.85           | 1.23           | 0.93           | 758                     |
| C9400-LC-24XY | 222                                          | 200                                     | 2.47          | 1.85           | 1.23           | 0.93           | 758                     |
| C9400-LC-48H  | 72                                           | 65                                      | 0.80          | 0.60           | 0.40           | 0.30           | 246                     |
| C9400-LC-48HN | 194                                          | 175                                     | 2.16          | 1.62           | 1.08           | 0.81           | 663                     |
| C9400-LC-48HX | 300                                          | 270                                     | 3.33          | 2.50           | 1.67           | 1.25           | 1024                    |
| C9400-LC-48P  | 72                                           | 65                                      | 0.80          | 0.60           | 0.40           | 0.30           | 246                     |
| C9400-LC-48S  | 189                                          | 170                                     | 2.10          | 1.57           | 1.05           | 0.79           | 644                     |
| C9400-LC-48T  | 72                                           | 65                                      | 0.80          | 0.60           | 0.40           | 0.30           | 246                     |
| C9400-LC-48U  | 72                                           | 65                                      | 0.80          | 0.60           | 0.40           | 0.30           | 246                     |
| C9400-LC-48UX | 267                                          | 240                                     | 2.96          | 2.22           | 1.48           | 1.11           | 910                     |
| C9400-LC-48XS | 278                                          | 250                                     | 3.09          | 2.31           | 1.54           | 1.16           | 948                     |

## Weight Specifications

The total weight of a fully configured chassis will depend on the type of chassis, the number of modules, and power supplies installed. Use the corresponding weights in the tables below to arrive at the total chassis weight for your hardware configuration.

### Chassis Weights

| PID (add "=" for spare) | Weight (Chassis with Fan Tray) |
|-------------------------|--------------------------------|
| C9404R                  | 39.0 lb (17.2 kg)              |
| C9407R                  | 63.0 lb (28.58 kg)             |
| C9410R                  | 65.0 lb (29.48 kg)             |

**Supervisor Module Weights**

| <b>PID (add "=" for spare)</b> | <b>Weight</b>     |
|--------------------------------|-------------------|
| C9400-SUP-1                    | 9.9 lb (4.5 kg)   |
| C9400-SUP-1XL                  | 9.9 lb (4.5 kg)   |
| C9400-SUP-1XL-Y                | 9.9 lb (4.5 kg)   |
| C9400X-SUP-2                   | 10.5 lb (4.78 kg) |
| C9400X-SUP-2XL                 | 10.5 lb (4.78 kg) |

**Line Card Weights**

| <b>PID (add "=" for spare)</b> | <b>Weight</b>    |
|--------------------------------|------------------|
| C9400-LC-12QC                  | 7.7 lb (3.49kgs) |
| C9400-LC-24S                   | 5.5 lb (2.49 kg) |
| C9400-LC-24XS                  | 6.9 lb (3.1 kg)  |
| C9400-LC-24XY                  | 7.4 lb (3.37kgs) |
| C9400-LC-48H                   | 6.9 lb (3.13 kg) |
| C9400-LC-48HN                  | 8.5 lb (3.85 kg) |
| C9400-LC-48HX                  | 8.4 lb (3.81 kg) |
| C9400-LC-48P                   | 6.6 lb (3.0 kg)  |
| C9400-LC-48S                   | 6.5 lb (2.94 kg) |
| C9400-LC-48T                   | 6.2 lb (2.82 kg) |
| C9400-LC-48U                   | 6.7 lb (3.0 kg)  |
| C9400-LC-48UX                  | 8.3 lb (3.8 kg)  |
| C9400-LC-48XS                  | 8.1 lb (3.67 kg) |

**Power Supply Module Weights**

| <b>PID (add = for spare)</b> | <b>Weight</b>   |
|------------------------------|-----------------|
| C9400-PWR-2100AC             | 5.0 lb (2.3 kg) |
| C9400-PWR-3200DC             | 6.6 lb (3.0 kg) |
| C9400-PWR-3200AC             | 5.0 lb (2.3 kg) |

**Blank Covers**

| <b>PID (add = for spare)</b>                                             | <b>Weight</b>     |
|--------------------------------------------------------------------------|-------------------|
| C9400-S-BLANK<br>(Cisco Catalyst 9400 Series Slot Blank Cover)           | 3.4 lb (1.54 kg)  |
| C9400-PWR-BLANK<br>(Cisco Catalyst 9400 Series Power Supply Blank Cover) | 0.14 lb (0.06 kg) |







# CHAPTER 9

## LEDs

- Fan Tray LEDs, on page 167
- Power Supply LEDs, on page 168
- Cisco Catalyst 9400 Series Line Card LEDs, on page 169
- Cisco Catalyst 9400 Series Supervisor Module LEDs, on page 170

## Fan Tray LEDs

*Table 23: Cisco Catalyst 9400 Series Fan Tray LEDs*

| LED Type                                                                                      | LED Position or Color | Meaning                                                                                                                                                                                                                                                                                                                                                                                                             |
|-----------------------------------------------------------------------------------------------|-----------------------|---------------------------------------------------------------------------------------------------------------------------------------------------------------------------------------------------------------------------------------------------------------------------------------------------------------------------------------------------------------------------------------------------------------------|
| <br>STATUS | Off                   | Fan tray is not getting any power.                                                                                                                                                                                                                                                                                                                                                                                  |
|                                                                                               | Green                 | All fans are running and the fan tray is operating normally.                                                                                                                                                                                                                                                                                                                                                        |
|                                                                                               | Amber                 | One fan is not running.                                                                                                                                                                                                                                                                                                                                                                                             |
|                                                                                               | Red                   | Two or more fans are not running.                                                                                                                                                                                                                                                                                                                                                                                   |
| <br>LOCATE | Blue                  | <p>Identifies the fan tray receiving the beacon signal.</p> <p>The fan tray assembly has two blue beacon LEDs, one on the front panel and one on the rear. The two will always match each other.</p> <p>The blue beacon LED on the front panel is also a switch that you can press, to turn the front and rear blue beacons on or off. Alternatively, you can turn the blue beacons on or off through software.</p> |



## Power Supply LEDs



**Note** AC Power Supply works when the AC input voltage is greater than 85 V. For normal operation, the INPUT LED on AC Power Supply should be solid green. If the INPUT LED on AC Power Supply is blinking green or off, check the AC power supply status. For more information, refer [Troubleshooting an AC-Input Power Supply, on page 134](#)

DC power supply works when DC input voltage is greater than 40 V. For normal operation, the INPUT LED on DC Power Supply should be solid green. If the INPUT LED on DC Power Supply is blinking green or off, check the DC power supply status. For more information, refer [Troubleshooting a DC-Input Power Supply, on page 135](#)



**Table 24: Cisco Catalyst 9400 Series Power Supply LEDs**

| LED type                                                                                      | LED Colour     | Meaning                                                                                                                                                                                                                                                                                                                                                                                                                                    |
|-----------------------------------------------------------------------------------------------|----------------|--------------------------------------------------------------------------------------------------------------------------------------------------------------------------------------------------------------------------------------------------------------------------------------------------------------------------------------------------------------------------------------------------------------------------------------------|
| <br>INPUT    | Green          | AC input voltage is 70 V minimum.<br>DC input voltage is -40 V minimum.                                                                                                                                                                                                                                                                                                                                                                    |
|                                                                                               | Off            | AC input voltage is less than 70 V.<br>DC input voltage is less than -40 V.                                                                                                                                                                                                                                                                                                                                                                |
|                                                                                               | Blinking Green | AC input voltage is between 70 V and 85 V.<br>DC input voltage is between -37 V and -41 V.                                                                                                                                                                                                                                                                                                                                                 |
| <br>OUTPUT | Green          | 55 VDC power supply output and power supply modules are operating within regulation limits.                                                                                                                                                                                                                                                                                                                                                |
|                                                                                               | Blinking Green | Standby mode or sleep mode.<br>Blinks on for 0.5 seconds and off for 0.5 seconds.                                                                                                                                                                                                                                                                                                                                                          |
| <br>FAIL   | Off            | DC output voltages have not exceeded the alarm threshold ranges.                                                                                                                                                                                                                                                                                                                                                                           |
|                                                                                               | Red            | An output voltage is out of the specified range, or the power supply module's fan has failed (as sensed by lack of fan rotation), or the power supply module is turned off after input power is applied.<br><br>Illuminates for 2-3 seconds after input is applied or disconnected through the front panel On/ Off rocker switch (for AC-input power supplies) or On/ Off power button (for DC-input power supplies) or a circuit breaker. |

| LED type                                                                                    | LED Colour    | Meaning                                                                                      |
|---------------------------------------------------------------------------------------------|---------------|----------------------------------------------------------------------------------------------|
| <br>LOCATE | Blue          | Module is receiving the beacon signal.                                                       |
|                                                                                             | Blinking Blue | Change in the DC-input power supply module's power button mode.<br><br>Blinks for 3 seconds. |





## Cisco Catalyst 9400 Series Line Card LEDs

Table 25: Cisco Catalyst 9400 Series Line Card LEDs



| LED                                                                                              | LED Color                   | Meaning                                                                                                                                                                       |
|--------------------------------------------------------------------------------------------------|-----------------------------|-------------------------------------------------------------------------------------------------------------------------------------------------------------------------------|
| <br>STATUS      | Green                       | All diagnostic tests have passed and the module is operational.                                                                                                               |
|                                                                                                  | Amber                       | The module is booting or running diagnostics or the module is disabled.                                                                                                       |
|                                                                                                  | Red                         | A test other than an individual port test has failed. On some modules, this LED turns red immediately after the system is powered on, until the software boot process begins. |
|                                                                                                  | Off                         | The module is disabled or is not powered up.                                                                                                                                  |
| <br>LOCATE    | Blue                        | Identifies the module receiving the beacon signal.                                                                                                                            |
| <br>PORT LINK | Green                       | Port link is up but there is no packet activity.                                                                                                                              |
|                                                                                                  | Blinking Green              | Port link is up and indicating packet activity.                                                                                                                               |
|                                                                                                  | Amber                       | Port link is disabled by the user, that is, administratively down.                                                                                                            |
|                                                                                                  | Blinking Amber              | Hardware (PHY) has detected a faulty port link.                                                                                                                               |
|                                                                                                  | Alternating Green and Amber | Error packets are being detected on the port link. The error packets could be bad Cyclic Redundancy Check (CRC) packets, jumbo packets, and so on.                            |
|                                                                                                  | Off                         | No signal is detected, the link is down, or the port is not connected.                                                                                                        |



## Cisco Catalyst 9400 Series Supervisor Module LEDs

Table 26: Cisco Catalyst 9400 Series Supervisor Module LEDs

| LED                                                                                               | LED Color | Meaning                                                                                                                                                           |
|---------------------------------------------------------------------------------------------------|-----------|-------------------------------------------------------------------------------------------------------------------------------------------------------------------|
| <br>STATUS       | Green     | All diagnostic tests have passed after correct image booting.                                                                                                     |
|                                                                                                   | Amber     | System boot or a diagnostic test is in progress.                                                                                                                  |
|                                                                                                   | Red       | A diagnostic test failed.                                                                                                                                         |
|                                                                                                   | Off       | The supervisor module is disabled or is not powered up.                                                                                                           |
| <br>LOCATE       | Blue      | Identifies the supervisor module receiving the beacon signal.                                                                                                     |
| <br>ACTIVE       | Green     | Supervisor module is the active supervisor (in redundant supervisor module configurations).                                                                       |
|                                                                                                   | Off       | Supervisor module is in standby mode (in redundant supervisor module configurations).                                                                             |
| <br>MANAGEMENT | Green     | The 10/100/1000 BASE-T Ethernet management port is operational (link up).                                                                                         |
|                                                                                                   | Off       | No signal is detected for the 10/100/1000 BASE-T Ethernet management port, or there is a link configuration failure, or the link is disabled by user (link down). |



| For C9400-SUP-1, C9400-SUP-1XL, and C9400-SUP-1XL-Y Only                                                                                                                                                                                                                                                                                                                                          |                             |                                                                                                                                                   |
|---------------------------------------------------------------------------------------------------------------------------------------------------------------------------------------------------------------------------------------------------------------------------------------------------------------------------------------------------------------------------------------------------|-----------------------------|---------------------------------------------------------------------------------------------------------------------------------------------------|
| LED                                                                                                                                                                                                                                                                                                                                                                                               | LED Color                   | Meaning                                                                                                                                           |
|  <p>SFP or SFP+ or SFP28 UPLINK STATUS</p> <p>Triangular LEDs pointing up or down, indicating the status of the corresponding port.</p>                                                                                                                                                                          | Green                       | SFP or SFP+ port link is up but there is no packet activity.                                                                                      |
|                                                                                                                                                                                                                                                                                                                                                                                                   | Blinking Green              | SFP or SFP+ port link is up and indicating packet activity.                                                                                       |
|                                                                                                                                                                                                                                                                                                                                                                                                   | Amber                       | SFP or SFP+ link is disabled by the user, that is, administratively down.                                                                         |
|                                                                                                                                                                                                                                                                                                                                                                                                   | Blinking Amber              | Hardware (PHY) has detected a faulty port link.                                                                                                   |
|                                                                                                                                                                                                                                                                                                                                                                                                   | Alternating Green and Amber | Error packets are being detected on the port link. The error packets could be bad Cyclic Redundancy Check (CRC) packets, jumbo packets, etc.      |
|                                                                                                                                                                                                                                                                                                                                                                                                   | Off                         | SFP or SFP+ port link is down or transceiver module is not installed.                                                                             |
|  <p>QSFP UPLINK STATUS</p> <p>LEDs next to each QSFP port number, indicating the status of the corresponding port.</p>                                                                                                                                                                                           | Green                       | QSFP port link is up but there is no packet activity.                                                                                             |
|                                                                                                                                                                                                                                                                                                                                                                                                   | Blinking Green              | QSFP port link is up and indicating packet activity.                                                                                              |
|                                                                                                                                                                                                                                                                                                                                                                                                   | Amber                       | QSFP port link is disabled by the user, that is, administratively down.                                                                           |
|                                                                                                                                                                                                                                                                                                                                                                                                   | Alternating Green and Amber | Error packets are being detected on the QSFP port link. The error packets could be bad Cyclic Redundancy Check (CRC) packets, jumbo packets, etc. |
|                                                                                                                                                                                                                                                                                                                                                                                                   | Off                         | QSFP port link is down or transceiver module is not installed.                                                                                    |
|  <p>PORT SET ENABLED</p> <p>There are four such LEDs on the supervisor module faceplate:</p> <ul style="list-style-type: none"> <li>• One for port numbers 1 to 4 (G1).</li> <li>• One for port numbers 5 to 8 (G2).</li> <li>• One for port number 9 (G3).</li> <li>• One for port number 10 (G4).</li> </ul> | Green                       | The port set is enabled.<br><br><b>Note</b> Starting with Cisco IOS XE Fuji 16.8.1a, PORT SET ENABLED LEDs for SFP or SFP+ ports are supported.   |
|                                                                                                                                                                                                                                                                                                                                                                                                   | Off                         | The port set is not enabled.                                                                                                                      |

| For C9400X-SUP-2 and C9400X-SUP-2XL Only                                                                                                                                                                  |                             |                                                                                                                                              |
|-----------------------------------------------------------------------------------------------------------------------------------------------------------------------------------------------------------|-----------------------------|----------------------------------------------------------------------------------------------------------------------------------------------|
| LED                                                                                                                                                                                                       | LED Color                   | Meaning                                                                                                                                      |
| <br>SFP+ or SFP28 UPLINK STATUS<br>Triangular LEDs pointing up or down, indicating the status of the corresponding port. | Green                       | SFP+ port link is up but there is no packet activity.                                                                                        |
|                                                                                                                                                                                                           | Blinking Green              | SFP+ port link is up and indicating packet activity.                                                                                         |
|                                                                                                                                                                                                           | Amber                       | SFP+ link is disabled by the user, that is, administratively down.                                                                           |
|                                                                                                                                                                                                           | Blinking Amber              | Hardware (PHY) has detected a faulty port link.                                                                                              |
|                                                                                                                                                                                                           | Alternating Green and Amber | Error packets are being detected on the port link. The error packets could be bad Cyclic Redundancy Check (CRC) packets, jumbo packets, etc. |
|                                                                                                                                                                                                           | Off                         | SFP+ port link is down or transceiver module is not installed.                                                                               |
| <br>QSFP UPLINK STATUS<br>Triangular LEDs pointing up, indicating the status of the corresponding port.                  | Green                       | QSFP port link is up but there is no packet activity.                                                                                        |
|                                                                                                                                                                                                           | Blinking Green              | QSFP port link is up and indicating packet activity.                                                                                         |
|                                                                                                                                                                                                           | Amber                       | QSFP link is disabled by the user, that is, administratively down.                                                                           |
|                                                                                                                                                                                                           | Blinking Amber              | Hardware (PHY) has detected a faulty port link.                                                                                              |
|                                                                                                                                                                                                           | Alternating Green and Amber | Error packets are being detected on the port link. The error packets could be bad Cyclic Redundancy Check (CRC) packets, jumbo packets, etc. |
|                                                                                                                                                                                                           | Off                         | QSFP port link is down or transceiver module is not installed.                                                                               |

| For C9400X-SUP-2 and C9400X-SUP-2XL Only                                                                                                                                                                                                                                                                                                                                                        |           |                              |
|-------------------------------------------------------------------------------------------------------------------------------------------------------------------------------------------------------------------------------------------------------------------------------------------------------------------------------------------------------------------------------------------------|-----------|------------------------------|
| LED                                                                                                                                                                                                                                                                                                                                                                                             | LED Color | Meaning                      |
| <br><b>PORT SET ENABLED</b><br>There are five such LEDs on the supervisor module faceplate: <ul style="list-style-type: none"><li>• One for port numbers 1 to 4.</li><li>• One for port number 5.</li><li>• One for port number 6.</li><li>• One for port number 7.</li><li>• One for port number 8.</li></ul> | Green     | The port set is enabled.     |
|                                                                                                                                                                                                                                                                                                                                                                                                 | Off       | The port set is not enabled. |





## CHAPTER 10

# Initial Configuration for the Switch

---

- [Options for Initial Configuration, on page 175](#)
- [Configuring the Switch Using the Web User Interface, on page 175](#)
- [Configuring the Switch Using the CLI, on page 176](#)
- [Configuring the Switch in the ROMMON Mode, on page 181](#)
- [Installing and Uninstalling the USB Driver, on page 181](#)

## Options for Initial Configuration

After you complete the hardware installation, you need to setup the switch with configuration required to enable traffic to pass through the network. On your first day with your new device, you can perform a number of tasks to ensure that your device is online, reachable and easily configured.

When the supervisor module is shipped, the factory default setting for `MANUAL_BOOT` is `no`. This means that when you first power on the device, it will always boot automatically. So these are the first options available to you for initial configuration:

- Configuring the Switch Using the Web User Interface
- Configuring the Switch Using the CLI
- Configuring the Switch in the ROMMON Mode

This option requires you to interrupt autoboot (factory default) and enter the ROMMON prompt to enter the required settings. Use this option if you want to boot the system by using an image that is located on a TFTP server.

## Configuring the Switch Using the Web User Interface

For instructions on setting up the switch using the WebUI, refer to the required version of the [software configuration guide](#). In the guide, go to *Configuring the Switch Using the Web User Interface*.

# Configuring the Switch Using the CLI

## Starting the Terminal-Emulation Software

To start the terminal emulation software, follow these steps:

### Before you begin

The terminal-emulation software—frequently a PC application such as Hyperterminal or ProcommPlus—makes communication between the switch and your PC or terminal possible.

### Procedure

---

- Step 1** Start the terminal-emulation program if you are using a PC or terminal.
- Step 2** Start a terminal-emulation session.
- Step 3** Configure the baud rate and character format of the PC or terminal to match these console port default characteristics:
- 9600 baud
  - 8 data bits
  - No flow control
  - 1 stop bit
  - No parity
- 

### What to do next

Connect to a power source.

## Connecting to a Power Source

To connect to a power source, follow these steps:

### Procedure

---

- Step 1** Connect one end of the supplied country-specific AC power cord to the power connector on the switch.
- Step 2** Plug the other end into a grounded 100 to 240 VAC, 50–60 Hz AC outlet.
- The switch powers on.

If you started the terminal-emulation program before you powered on your switch, the PC or terminal displays the bootloader sequence. You need to press Enter to display the setup program prompt.

---

#### What to do next

Obtain IP settings from your network administrator.

## Connecting the RJ-45 Console Port

To use the console port to perform the initial configuration, connect the switch console port to a PC that uses a VT-100 terminal emulator. Use an RJ-45-to-DB-9 adapter cable for this.

To connect the PC or terminal to the switch, follow these steps:

#### Procedure

---

- Step 1** Using an RJ-45-to-DB-9 adapter cable, insert the RJ-45 connector into the console port that is located on the front panel of the supervisor module.
- Step 2** Attach the DB-9 female DTE of the adapter cable to a PC serial port, or attach an appropriate adapter to the terminal.
- 

## Connecting the USB Console Port

#### Procedure

---

- Step 1** .
- Note** USB Type A port on the switch provides file system support and is **NOT** a console port. See USB Type A Port section.
- Step 2** Connect a USB cable to the PC USB port. Connect the other end of the cable to the switch mini-B (5-pin-connector) USB console port.
- Step 3** Start the terminal-emulation program on the PC or the terminal. The program, frequently a PC application such as Putty or TeraTerm, makes communication between the switch and your PC or terminal possible.
- Step 4** Configure the baud rate and character format of the PC or terminal to match the console port default characteristics:
- 9600 baud
  - 8 data bits
  - 1 stop bit
  - No parity
  - None (flow control)

- Step 5** Power on the switch as described in the switch getting started guide.
- Step 6** The PC or terminal displays the bootloader sequence. Press **Enter** to display the setup prompt. Follow the steps in the Setup program.
- 

## IP Settings

To set up the switch, you need to assign an IP address and other configuration information necessary for the switch to communicate with the local routers and the Internet.

You will need this information from your network administrator:

- Switch IP address
- Subnet mask (IP netmask)
- Default gateway (router)
- TFTP Server

## Performing the Initial Configuration

The bootup script runs the configuration wizard, which prompts you for basic configuration input. At any point you may enter a question mark '?' for help. Use Ctrl+C to abort the configuration dialog at any prompt. Default settings are in square brackets '[' ]'.

### Procedure

---

- Step 1** Respond to whether you would like to enter the initial configuration dialog

**Example:**

```
Would you like to enter the initial configuration dialog? [yes/no]: yes
```

- Step 2** Respond to whether you would like to enter basic management setup

**Example:**

```
Would you like to enter basic management setup? [yes/no]: yes
```

- Step 3** Respond to whether you would like to enter basic management setup

**Example:**

```
Would you like to enter basic management setup? [yes/no]: yes
Configuring global parameters:
Enter host name [Switch]: Switch
```

```
The enable secret is a password used to protect access to
privileged EXEC and configuration modes. This password, after
entered, becomes encrypted in the configuration.
```

```
Enter enable secret: examplesecret
```

```
The enable password is used when you do not specify an
enable secret password, with some older software versions, and
some boot images.
```

```
Enter enable password: exampleenable
```



```

The virtual terminal password is used to protect
access to the router over a network interface.
Enter virtual terminal password: examplevtp
Setup account for accessing HTTP server? [yes]: yes
 Username [admin]:
 Password [cisco]:
 Password is UNENCRYPTED.

```

**Step 4** Respond to whether you would like to set up an account to access the HTTP server.

**Example:**

```

Setup account for accessing HTTP server? [yes]: yes
 Username [admin]:
 Password [cisco]:
 Password is UNENCRYPTED.

```

**Step 5** Respond to whether you would like to configure SNMP network management.

**Example:**

```

Configure SNMP Network Management? [no]: no

```

**Step 6** The system displays the interface summary. From the list, enter the interface name used to connect to the management network, and then enter the IP address and subnet mask for the interface

**Example:**

```

Current interface summary
Any interface listed with OK? value "NO" does not have a valid configuration

Interface IP-Address OK? Method Status Protocol
Vlan1 unassigned NO unset up up
GigabitEthernet0/0 unassigned NO unset up up
GigabitEthernet1/0/1 unassigned YES unset down down
<output truncated>

```

```

Enter interface name used to connect to the
management network from the above interface summary: GigabitEthernet0/0

```

```

Configuring interface GigabitEthernet0/0:
 Configure IP on this interface? [yes]:
 IP address for this interface: 192.168.247.10
 Subnet mask for this interface [255.255.255.0] : 255.255.0.0
 Class C network is 192.168.247.0, 16 subnet bits; mask is /16

```

```

The following configuration command script was created:
hostname Switch
enable secret 5 $1$2EYv$CSkmxAlgDon2AKcfXNNwT/
enable password exampleenable
line vty 0 4
password examplevtp
username admin privilege 15 password cisco
no snmp-server
!
!
interface Vlan1
shutdown
no ip address
!

```

```

interface GigabitEthernet0/0
no shutdown
ip address 192.168.247.10 255.255.0.0
!
interface GigabitEthernet1/0/1
!
interface GigabitEthernet1/0/2
<output truncated>
end

```

### Step 7 Save configuration and then verify running-configuration

#### Example:

```

[0] Go to the IOS command prompt without saving this config.
[1] Return back to the setup without saving this config.
[2] Save this configuration to nvram and exit.

```

```

Enter your selection [2]: 2
Building configuration...
[OK]
Use the enabled mode 'configure' command to modify this configuration.

```

Press RETURN to get started!

```

*Aug 17 21:16:56.780: %PKI-4-NOCONFIGAUTOSAVE: Configuration was modified. Issue "write
memory" to save new IOS PKI configuration

```

```

Switch> enable
Password: exampleenable
Switch#
Switch# show running-config interface GigabitEthernet0/0
Building configuration...

```

```

Current configuration : 118 bytes
!
interface GigabitEthernet0/0
 vrf forwarding Mgmt-vrf
 ip address 192.168.247.10 255.255.0.0
 negotiation auto

```

end

### Step 8 Ping an interface using the Ethernet management interface through the VRF

```

Switch# ping vrf Mgmt-vrf 192.168.0.1
Type escape sequence to abort.
Sending 5, 100-byte ICMP Echos to 192.168.0.1, timeout is 2 seconds:
.!!!!
Success rate is 80 percent (4/5), round-trip min/avg/max = 1/1/1 ms
Switch#
*Aug 17 21:18:45.152: %PNP-6-PNP_DISCOVERY_STOPPED: PnP Discovery stopped (Config Wizard)

```

You have now completed the initial configuration of the switch, so you can now configure other interfaces and features over a network connection without having to directly connect to the console port of the supervisor module.

To use the CLI to perform additional configuration or management tasks, enter commands at the Switch> prompt through the console port by using a terminal program or through the network by using Telnet. For configuration information, see the switch software configuration guide along with the switch command reference.

# Configuring the Switch in the ROMMON Mode

## Procedure

---

- Step 1** The system is setup for autoboot. In order to change network parameters in the ROMMON, connect the console to system and while system is booting, after you see the the prompt, press CTRL+C to stop booting and access ROMMON prompt.

**Example:**

```
Initializing Hardware...

System Bootstrap, Version 16.6.1r [FC2], RELEASE SOFTWARE (P)
Compiled Sat 07/15/2017 10:06:12.23 by rel

Current image running:
Primary Rommon Image

Last reset cause: SoftwareResetTrig
C9400-SUP-1 platform with 16777216 Kbytes of main memory

Preparing to autoboot. [Press Ctrl-C to interrupt] 0
<output truncated>
rommon1>
```

- Step 2** Set the network parameters. The values entered here are only meant to serve as examples.

**Example:**

```
rommon 2> set IP_ADDRESS=192.168.247.10
rommon 3> set IP_SUBNET_MASK=255.255.0.0
rommon 4> set DEFAULT_GATEWAY=172.20.52.35
rommon 5> set TFTP_SERVER=198.51.100.2
```

- Step 3** Enter the set command to ensure settings are saved and then boot the system

**Example:**

```
rommon 6> set
rommon 7> boot
```

---

## Installing and Uninstalling the USB Driver

### Installing the Microsoft Windows USB Device Driver

A USB device driver must be installed the first time a Microsoft Windows-based PC is connected to the USB console port on the switch.

## Installing the Cisco Microsoft Windows USB Driver

### Procedure

---

- Step 1** Obtain the Cisco USB console driver file from the Cisco.com web site and unzip it.
- Note** You can download the driver file from the Cisco.com site for downloading the switch software.
- Windows 10 includes a USB to RS232 driver. However for added functionality, download the USB Console Software from the Software Download Center for Catalyst 3850 Series Switches at cisco.com.
- Step 2** If using 32-bit Windows, double-click the setup.exe file in the Windows\_32 folder. If using 64-bit Windows, double-click the setup(x64).exe file in the Windows\_64 folder.
- Step 3** The Cisco Virtual Com InstallShield Wizard begins. Click **Next**.
- Step 4** The Ready to Install the Program window appears. Click **Install**.
- Note** If a User Account Control warning appears, click **Allow - I trust this program** to proceed.
- Step 5** The InstallShield Wizard Completed window appears. Click **Finish**.
- Step 6** Connect the USB cable to the PC and the switch console port. The USB console port LED turns green, and the Found New Hardware Wizard appears. Follow the instructions to complete the driver installation.
- 

## Uninstalling the Cisco Microsoft Windows USB Driver

### Uninstalling the Cisco Microsoft Windows USB Driver

#### Before you begin

Disconnect the switch console terminal before uninstalling the driver.

#### Procedure

---

- Step 1** Run setup.exe for Windows 32-bit or setup(x64).exe for Windows-64bit. Click **Next**.
- Step 2** The InstallShield Wizard for Cisco Virtual Com appears. Click **Next**.
- Step 3** When the Program Maintenance window appears, select the Remove radio button. Click **Next**.
- Step 4** When the Remove the Program window appears, click **Remove**.
- Note** If a User Account Control warning appears, click **Allow - I trust this program** to proceed.
- Step 5** When the InstallShield Wizard Completed window appears, click **Finish**.
-



# CHAPTER 11

## Related Documentation

---

For related installation and configuration information, refer to the following:

### Release and General Information

Release Notes: <https://www.cisco.com/c/en/us/support/switches/catalyst-9400-series-switches/products-release-notes-list.html>

Provides an overview of the hardware and software features introduced in every release, unsupported features, important restrictions and limitations, and open and resolved caveats with the software.

### Hardware Documentation

- Hardware Installation Guide: [https://www.cisco.com/c/en/us/td/docs/switches/lan/catalyst9400/hardware/install/b\\_c9400\\_hig.html](https://www.cisco.com/c/en/us/td/docs/switches/lan/catalyst9400/hardware/install/b_c9400_hig.html)

Provides a functional overview of the switch, describes how to install and rack-mount the switch, and make connections to the switch. It describes how to install the power supplies and how to replace the fan tray assembly. It also includes technical specifications and troubleshooting guidance.

- Supervisor Module Installation Note: [https://www.cisco.com/c/en/us/td/docs/switches/lan/catalyst9400/hardware/sup\\_install/b-c9400-sup-note.html](https://www.cisco.com/c/en/us/td/docs/switches/lan/catalyst9400/hardware/sup_install/b-c9400-sup-note.html)

Provides an overview of the available supervisor modules, major features, chassis compatibility information, slot restrictions, and describes how to correctly install and uninstall a supervisor module.

- Line Card Installation Note: [https://www.cisco.com/c/en/us/td/docs/switches/lan/catalyst9400/hardware/sw\\_mod\\_install/b-c9400-mod-note.html](https://www.cisco.com/c/en/us/td/docs/switches/lan/catalyst9400/hardware/sw_mod_install/b-c9400-mod-note.html)

Provides an overview of the supported line cards, major features, describes how to correctly install and uninstall a line card, and transceiver support.

- Regulatory Compliance & Safety Information Document: <https://www.cisco.com/c/dam/en/us/td/docs/switches/lan/catalyst9400/hardware/regulatory/RCSI-0315-book.pdf>

Consolidated list of safety warnings relevant to Catalyst 9400 Series Switches (all chassis models), supervisor modules, line cards and any other hardware components.

### Software Documentation

- Software Configuration Guide: <https://www.cisco.com/c/en/us/support/switches/catalyst-9400-series-switches/products-installation-and-configuration-guides-list.html>

Provides detailed software configuration information for the features supported on the switch. These guides are release-specific.

- Command Reference: <https://www.cisco.com/c/en/us/support/switches/catalyst-9400-series-switches/products-command-reference-list.html>

Provides command syntax, command history and usage guidelines for the Cisco IOS commands supported on the switch. These guides are release-specific.



## APPENDIX **A**

# Analysis of Cabling Requirements for IEEE 802.3bt Type 4 Devices

The National Electrical Code (NEC) in its 2017 edition describes the restrictions on Power over Ethernet (PoE) systems. The restrictions are based on the per-conductor current and are targeted to minimize the thermal rise that may occur in large bundles of cable delivering Power over Ethernet.



**Note** The NEC defines a cable bundle as a group of cables that are tied together or in contact with one another in a closely packed configuration for at least 1.0m (40 in).

A standard Category cable used in Ethernet systems consists of eight conductors. IEEE 802.3af and 802.3at systems use only four of these conductors to carry current. Cisco UPOE and IEEE 802.3bt systems use all eight conductors to carry current. The following table lists the maximum current allowed under each standard and the associated per-cable and per-conductor current.

**Table 27: Maximum Current prescribed for various Standards**

| Standard   | Cable Current | Conductor Current |
|------------|---------------|-------------------|
| 802.3af    | 350mA         | 175mA             |
| 802.3at    | 600mA         | 300mA             |
| Cisco UPOE | 1200mA        | 300mA             |
| 802.3bt    | 1732mA        | 433mA             |

Analysis of a cabling system for compliance to the NEC starts with section 840.160:

Installation of the listed 4-pair communication cables for a communication circuit or installation where 4-pair communication cables are substituted for Class 2 and Class 3 cables in accordance with 725.154(A) shall comply with 725.144.

*Exception: Installing communications cables in compliance with 725.144 shall not be required for listed 4-pair communications cables where the rated current of the power source does not exceed 0.3 amperes in any conductor 24 AWG or larger.*

This, in effect states that 802.3af, 802.3at, and Cisco UPOE systems do not require any further consideration when the conductors are 24AWG or larger. Also, TIA-568 compliant horizontal cables require a minimum

of 24AWG conductors. Hence any IEEE standard compliant PoE system that supplies 60W or less does not need additional cable consideration.

IEEE 802.3bt Type 4 systems (Class 7 and Class 8, 75W and 90W) do not qualify for the 0.3A exemption. Therefore, the analysis for compliance to NEC moves to section 725.144:

Where Types CL3P, CL2P, CL3R, CL2R, CL3, or CL2 transmit power and data, the rated current per conductor shall not exceed the ampacities in Table 725.144 at an ambient temperature of 30°C (86°F). For ambient temperatures above 30°C (86°F), the correction factors of 310.15(B) shall apply.

*Exception: Compliance with 725.144 shall not be required for installations where conductors are 24 AWG or larger and the rated current of the power source does not exceed 0.3 amperes.*

Types CL3P-LP, CL2P-LP, CL3R-LP, CL2R-LP, CL3-LP, or CL2-LP shall be permitted to supply power to equipment from a power source with a rated current per conductor up to the marked ampere limit located immediately following the suffix “-LP” and shall be permitted to transmit data to the equipment.

The following table is derived from Table 725.144, adjusted for 45°C ambient temperature using 310.15(B).

The values in green cells are accepted values for IEEE Type 4 PoE systems.

**Figure 72: NEC 2020 Table 725.144 adjusted for 45°C ambient temperature**

| AWG | Number of 4-Pair Cables in a Bundle |      |      |                    |      |      |                    |      |      |                    |      |      |                    |      |      |                    |      |      |
|-----|-------------------------------------|------|------|--------------------|------|------|--------------------|------|------|--------------------|------|------|--------------------|------|------|--------------------|------|------|
|     | 1-7                                 |      |      | 8-19               |      |      | 20-37              |      |      | 38-61              |      |      | 62-91              |      |      | 92-192             |      |      |
|     | Temperature Rating                  |      |      | Temperature Rating |      |      | Temperature Rating |      |      | Temperature Rating |      |      | Temperature Rating |      |      | Temperature Rating |      |      |
|     | 60°C                                | 75°C | 90°C | 60°C               | 75°C | 90°C | 60°C               | 75°C | 90°C | 60°C               | 75°C | 90°C | 60°C               | 75°C | 90°C | 60°C               | 75°C | 90°C |
| 26  | 0.71                                | 1.00 | 1.23 | 0.50               | 0.71 | 0.88 | 0.39               | 0.56 | 0.68 | 0.33               | 0.47 | 0.58 | 0.32               | 0.45 | 0.55 | NA                 | NA   | NA   |
| 24  | 0.84                                | 1.19 | 1.46 | 0.57               | 0.82 | 1.01 | 0.45               | 0.64 | 0.79 | 0.39               | 0.55 | 0.68 | 0.33               | 0.46 | 0.56 | 0.28               | 0.39 | 0.48 |
| 23  | 0.88                                | 1.25 | 1.54 | 0.63               | 0.91 | 1.11 | 0.54               | 0.78 | 0.95 | 0.47               | 0.65 | 0.81 | 0.41               | 0.58 | 0.71 | 0.32               | 0.45 | 0.55 |
| 22  | 1.06                                | 1.52 | 1.87 | 0.74               | 1.05 | 1.29 | 0.54               | 0.78 | 0.96 | 0.47               | 0.67 | 0.83 | 0.44               | 0.63 | 0.77 | 0.37               | 0.51 | 0.62 |

Analysis of the NEC 2020 Table 725.144, adjusted for 45°C, and the requirements of section 725.144 results in Cisco’s recommendation to use Category 6a cables rated at 75°C, with 23AWG conductors, in bundles sizes of 192 or less.





## INDEX

- 9404R [147](#)
    - airflow [147](#)
    - altitude [147](#)
    - ambient temperature [147](#)
    - chassis weight [147](#)
    - dimensions [147](#)
    - humidity [147](#)
    - rack units [147](#)
    - random vibration [147](#)
    - shock [147](#)
    - sine vibration [147](#)
    - sound pressure [147](#)
    - thermal transition temperature [147](#)
  - 9407R [149](#)
    - airflow [149](#)
    - altitude [149](#)
    - ambient temperature [149](#)
    - chassis weight [149](#)
    - dimensions [149](#)
    - humidity [149](#)
    - rack units [149](#)
    - random vibration [149](#)
    - shock [149](#)
    - sine vibration [149](#)
    - sound pressure [149](#)
    - thermal transition temperature [149](#)
- ### A
- AC input [100, 104](#)
  - AC-input power supply module [20](#)
    - features [20](#)
- ### B
- BAUD environment variable [141](#)
  - BTU/hour [162](#)
- ### C
- C9404R [5](#)
    - features [5](#)
  - C9407R [9](#)
    - features [9](#)
  - C9410R [13, 151](#)
    - airflow [151](#)
    - altitude [151](#)
    - ambient temperature [151](#)
    - chassis weight [151](#)
    - dimensions [151](#)
    - features [13](#)
    - humidity [151](#)
    - rack units [151](#)
    - random vibration [151](#)
    - shock [151](#)
    - sine vibration [151](#)
    - sound pressure [151](#)
    - thermal transition temperature [151](#)
  - Cisco Catalyst 9400 Series Switches [5, 9, 13, 49, 53, 56–57, 61, 63, 69, 72, 83, 88](#)
    - C9404R [5](#)
    - C9407R [9](#)
    - C9410R [13](#)
    - installing [49, 83, 88](#)
      - establishing system ground [83](#)
      - tasks [49](#)
      - verifying [88](#)
    - installing the switch chassis [53, 56–57, 61, 63, 69, 72](#)
      - cable guide [69, 72](#)
      - installing shelf brackets [61](#)
      - L brackets [57](#)
      - rack-mounting [53, 63](#)
      - shelf kit [56](#)
  - console port speed [141](#)
- ### D
- DC input [113, 119](#)
  - DC-input power supply module [22, 122–124, 127](#)
    - auto-on [127](#)
    - circuits, order [124](#)
    - colors, DC-input wires [122](#)
    - fastening torque, lugs [123](#)
    - features [22](#)
    - power button [22](#)
      - auto-on [22](#)
      - protected [22](#)

**E**

electricity [36](#)

**F**

fan tray [17–19](#), [89–90](#), [93–94](#), [97–98](#), [137](#), [139](#), [162](#), [167](#)  
   hot-swapping [89](#)  
   installing, from the front [93](#)  
   installing, from the rear [97](#)  
   LEDs [167](#)  
   model numbers [18](#)  
   Network Equipment-Building System mode (NEBS mode) [19](#)  
   OIR [89](#)  
   operation [19](#)  
   overview [17](#)  
   parts [18](#)  
   power requirements and heat dissipation [162](#)  
   removing, from the front [90](#)  
   removing, from the rear [94](#)  
   service mode [90](#)  
   thresholds, alarms, and abnormal acoustic conditions [19](#)  
   troubleshooting [137](#), [139](#)  
   verifying installation [98](#)  
 fan tray assembly [17](#)  
 FRUs [89](#), [99](#)  
   fan tray [89](#)  
   power supply module [99](#)

**H**

heat-shrink sleeve [122](#)  
 hot-swapping [99](#)  
 Humidity [30](#)

**I**

IEC60320/C19 appliance connector [154](#), [158](#)  
 initial configuration dialog [178](#)  
 initial configuration for the switchconnecting to a power source [176](#)  
 installing [85](#)  
   attaching an ESD strap [85](#)

**L**

LEDs [167](#), [170](#)  
 line cards [162](#)  
   power requirements and heat dissipation [162](#)

**P**

power redundancy-mode [24](#)

power supply module [20](#), [24–26](#), [99–100](#), [104](#), [107](#), [112–114](#), [117](#), [119](#), [121](#), [126–127](#), [129](#), [134–136](#), [153–154](#), [157–158](#), [161](#), [168](#)  
   AC input [99](#), [107](#)  
     power cord retainer [107](#)  
   C9400-PWR-2100AC [20](#)  
   C9400-PWR-3200AC [20](#)  
   C9400-PWR-3200DC [20](#)  
   DC input [99](#), [136](#)  
     power button [136](#)  
       restoring default (auto-on) [136](#)  
   hot-swapping [99](#)  
   installation considerations [25–26](#)  
     AC input and DC input (n+1, combined) [26](#)  
     AC input and DC input (n+n) [26](#)  
     AC input only [25](#)  
   installing [104](#), [119](#), [121](#), [126](#), [129](#)  
     AC input [104](#)  
     DC input [119](#), [121](#), [126](#)  
       connecting DC-Input Wires [121](#)  
       installing in the chassis [119](#)  
       powering up [126](#)  
     verifying [129](#)  
   LEDs [168](#)  
     AC input [168](#)  
     DC input [168](#)  
   modes [24](#)  
     combined mode [24](#)  
     redundant modes (n+1, n+n) [24](#)  
   overview [20](#)  
   power supply blank [127](#)  
   removing [100](#), [113–114](#), [117](#)  
     AC input [100](#)  
     DC input [113–114](#), [117](#)  
       disconnecting DC-Input Wires [114](#)  
       powering down [113](#)  
       removing from the chassis [117](#)  
   removing and installing [100](#), [112](#)  
     AC input [100](#)  
     DC input [112](#)  
   technical specifications [153–154](#), [157–158](#), [161](#)  
     2100-W AC power cords [154](#)  
     2100-W AC-Input Power Supply Module [153](#)  
     3200-W AC power cords [158](#)  
     3200-W AC-Input Power Supply Module [157](#)  
     3200-W DC-Input Power Supply Module [161](#)  
   troubleshooting [134–135](#)  
     AC input [134](#)  
     DC input [135](#)  
   preparing [38](#), [43](#)  
     cabling requirements [43](#)  
     power requirements [38](#)  
     rack-mounting guidelines [43](#)  
   preparing for installation [28](#), [30–34](#), [36](#)  
     air flow [28](#)  
     air quality [31](#)  
     altitude [30](#)

preparing for installation (*continued*)

- corrosion [31](#)
  - dust [30](#)
  - Electromagnetic interference [32](#)
  - particles [30](#)
  - power source interruptions [33](#)
  - radio frequency interference [32](#)
  - safety [36](#)
  - shock [33](#)
  - system grounding [34](#)
  - temperature [28](#)
  - vibration [33](#)
- preventing ESD damage [37](#)

**R**

- removing and replacing [89, 99–100, 112](#)
  - fan tray [89](#)
  - power supply module [99–100, 112](#)
    - AC input [100](#)
    - DC input [112](#)

**S**

- service mode [90](#)
- Site Requirements [27](#)
- standard accessory kit [47](#)
- start-up configuration [141](#)
- starting the terminal-emulation software [176](#)
- supervisor module [162](#)
  - power requirements and heat dissipation [162](#)

**T**

- technical specifications [147, 149, 151, 153, 157, 161–163](#)
  - 2100-W AC-Input Power Supply Module [153](#)
  - 3200-W AC-Input Power Supply Module [157](#)
  - 3200-W DC-Input Power Supply Module [161](#)
  - C9404R [147](#)
  - C9407R [149](#)
  - C9410R [151](#)
  - power and heat values [162](#)
  - weights [163](#)
- troubleshooting [131–135, 137, 139, 146](#)
  - about [131](#)
  - AC-input power supply module [134](#)
  - Cisco TAC [146](#)
  - DC-input power supply module [135](#)
  - fan tray [137](#)
  - fan tray CLI commands [139](#)
  - power supply CLI commands [134](#)
  - system boot verification [131](#)
  - system messages [133](#)
  - using LEDs to identify problems [132](#)
  - with software [133](#)

**W**

- weight [163](#)
  - chassis [163](#)
  - line cards [163](#)
  - power supply module [163](#)
  - supervisor module [163](#)



THE SPECIFICATIONS AND INFORMATION REGARDING THE PRODUCTS IN THIS MANUAL ARE SUBJECT TO CHANGE WITHOUT NOTICE. ALL STATEMENTS, INFORMATION, AND RECOMMENDATIONS IN THIS MANUAL ARE BELIEVED TO BE ACCURATE BUT ARE PRESENTED WITHOUT WARRANTY OF ANY KIND, EXPRESS OR IMPLIED. USERS MUST TAKE FULL RESPONSIBILITY FOR THEIR APPLICATION OF ANY PRODUCTS.

THE SOFTWARE LICENSE AND LIMITED WARRANTY FOR THE ACCOMPANYING PRODUCT ARE SET FORTH IN THE INFORMATION PACKET THAT SHIPPED WITH THE PRODUCT AND ARE INCORPORATED HEREIN BY THIS REFERENCE. IF YOU ARE UNABLE TO LOCATE THE SOFTWARE LICENSE OR LIMITED WARRANTY, CONTACT YOUR CISCO REPRESENTATIVE FOR A COPY.

The following information is for FCC compliance of Class A devices: This equipment has been tested and found to comply with the limits for a Class A digital device, pursuant to part 15 of the FCC rules. These limits are designed to provide reasonable protection against harmful interference when the equipment is operated in a commercial environment. This equipment generates, uses, and can radiate radio-frequency energy and, if not installed and used in accordance with the instruction manual, may cause harmful interference to radio communications. Operation of this equipment in a residential area is likely to cause harmful interference, in which case users will be required to correct the interference at their own expense.

The following information is for FCC compliance of Class B devices: This equipment has been tested and found to comply with the limits for a Class B digital device, pursuant to part 15 of the FCC rules. These limits are designed to provide reasonable protection against harmful interference in a residential installation. This equipment generates, uses and can radiate radio frequency energy and, if not installed and used in accordance with the instructions, may cause harmful interference to radio communications. However, there is no guarantee that interference will not occur in a particular installation. If the equipment causes interference to radio or television reception, which can be determined by turning the equipment off and on, users are encouraged to try to correct the interference by using one or more of the following measures:

- Reorient or relocate the receiving antenna.
- Increase the separation between the equipment and receiver.
- Connect the equipment into an outlet on a circuit different from that to which the receiver is connected.
- Consult the dealer or an experienced radio/TV technician for help.

Modifications to this product not authorized by Cisco could void the FCC approval and negate your authority to operate the product.

The Cisco implementation of TCP header compression is an adaptation of a program developed by the University of California, Berkeley (UCB) as part of UCB's public domain version of the UNIX operating system. All rights reserved. Copyright © 1981, Regents of the University of California.

NOTWITHSTANDING ANY OTHER WARRANTY HEREIN, ALL DOCUMENT FILES AND SOFTWARE OF THESE SUPPLIERS ARE PROVIDED "AS IS" WITH ALL FAULTS. CISCO AND THE ABOVE-NAMED SUPPLIERS DISCLAIM ALL WARRANTIES, EXPRESSED OR IMPLIED, INCLUDING, WITHOUT LIMITATION, THOSE OF MERCHANTABILITY, FITNESS FOR A PARTICULAR PURPOSE AND NONINFRINGEMENT OR ARISING FROM A COURSE OF DEALING, USAGE, OR TRADE PRACTICE.

IN NO EVENT SHALL CISCO OR ITS SUPPLIERS BE LIABLE FOR ANY INDIRECT, SPECIAL, CONSEQUENTIAL, OR INCIDENTAL DAMAGES, INCLUDING, WITHOUT LIMITATION, LOST PROFITS OR LOSS OR DAMAGE TO DATA ARISING OUT OF THE USE OR INABILITY TO USE THIS MANUAL, EVEN IF CISCO OR ITS SUPPLIERS HAVE BEEN ADVISED OF THE POSSIBILITY OF SUCH DAMAGES.

Any Internet Protocol (IP) addresses and phone numbers used in this document are not intended to be actual addresses and phone numbers. Any examples, command display output, network topology diagrams, and other figures included in the document are shown for illustrative purposes only. Any use of actual IP addresses or phone numbers in illustrative content is unintentional and coincidental.

All printed copies and duplicate soft copies of this document are considered uncontrolled. See the current online version for the latest version.

Cisco has more than 200 offices worldwide. Addresses and phone numbers are listed on the Cisco website at [www.cisco.com/go/offices](http://www.cisco.com/go/offices).

Cisco and the Cisco logo are trademarks or registered trademarks of Cisco and/or its affiliates in the U.S. and other countries. To view a list of Cisco trademarks, go to this URL: <https://www.cisco.com/c/en/us/about/legal/trademarks.html>. Third-party trademarks mentioned are the property of their respective owners. The use of the word partner does not imply a partnership relationship between Cisco and any other company. (1721R)

© 2017–2023 Cisco Systems, Inc. All rights reserved.

