

LDP217-121C

All-in-One Direct View LED Display

Installation Guide

快速入門指南

Guide de démarrage rapide

Schnellstartanleitung

Guía rápida de inicio

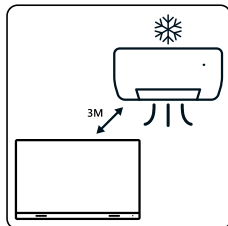
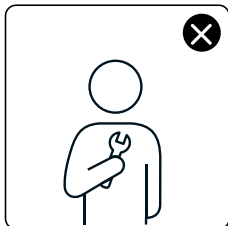
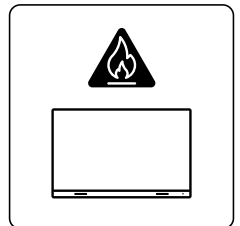
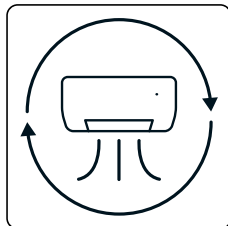
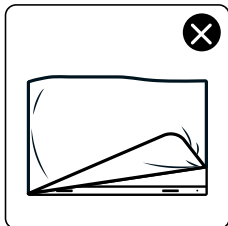
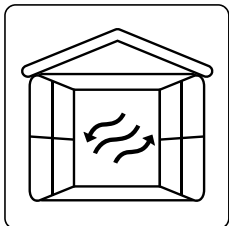
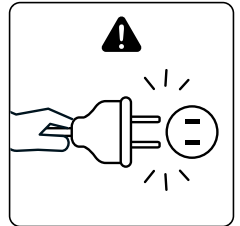
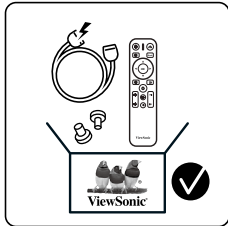
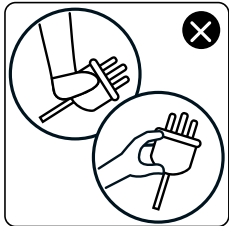
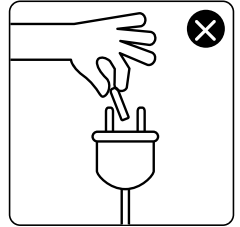
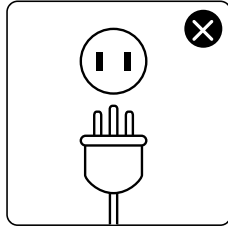
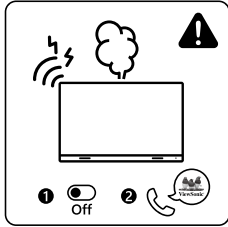
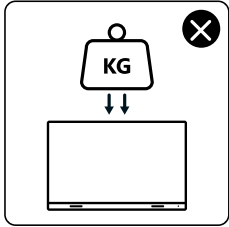
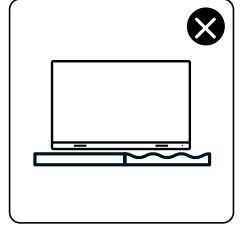
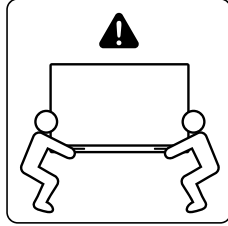
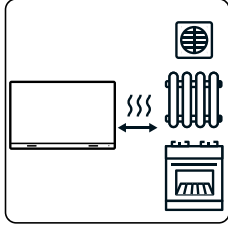
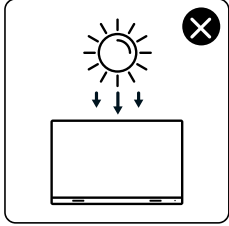
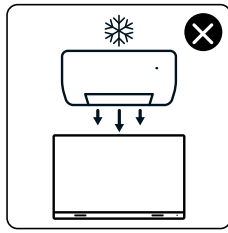
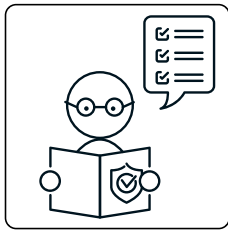
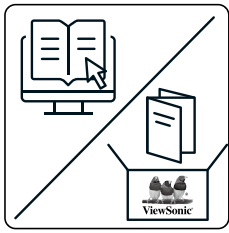

FCC Compliance Statement

This device complies with part 15 of FCC Rules. Operation is subject to the following two conditions: (1) this device may not cause harmful interference, and (2) this device must accept any interference received, including interference that may cause undesired operation.

Industry Canada ICES-003 Statement: CAN ICES (B) / NMB (B)

CE Conformity for European Countries

The device complies with the EMC Directive 2014/30/EU, Low Voltage Directive 2014/35/EU and Radio Equipment Directive 2014/53/EU.

Declaration of RoHS2 Compliance

This product has been designed and manufactured in compliance with Directive 2011/65/EU of the European Parliament and the Council on restriction of the use of certain hazardous substances in electrical and electronic equipment (RoHS2 Directive) and is deemed to comply with the maximum concentration values issued by the European Technical Adaptation Committee (TAC).

For EU users, please contact us for any safety/accident issue experienced with this product:

ViewSonic Europe Limited



Haaksbergweg 75
1101 BR Amsterdam
Netherlands



+31 (0) 650608655



EPREL@viewsoniceurope.com









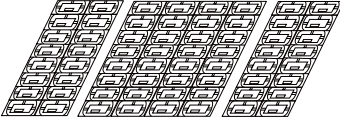

<https://www.viewsonic.com/eu/>

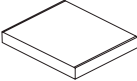
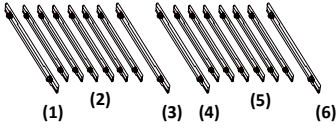

Package Contents

- ❗ It is recommended to use pliers to open the shipping crate.
- ❗ Please wear protective gear, such as gloves and protective shoes, at all times.

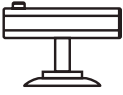
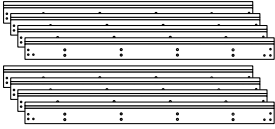
Before the installation, please take a moment to check if all components are included in the crate. The contents inside the case can be identified by the product labels on it. If anything is missing or damaged, contact your dealer immediately.

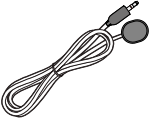
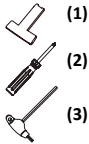
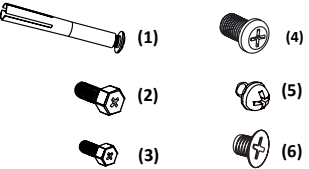
	Item	Quantity	Note
Installation Guide		1	
Cabinet Sections		16 sections total	Eight Cabinets labeled: A~H
Locking Plates		16	
LED Modules		512 modules	The quantity of spare LED modules varies by country.
Screen Bezels		16	1 x Top Left (1) 6 x Left (2) 1 x Bottom Left (3) 1 x Top Right (4) 6 x Right (5) 1 x Bottom Right (6)
System Control Box		2 sides	
System Control Box Covers		2 sides	
Connector Plate		1	

Item	Quantity	Note
System Control Box Maintenance Tool		1 P/N: LD-MK-004
LED Module Maintenance Tool		1 P/N: LD-MK-006
Wall Mount Brackets		8
Wall Mount Connector Plates		6
IR Extension Cable		1 3 m
Hand Tools	 <p>(1) (2) (3)</p>	2 x Cabinet magnet adjustment tools (1) 2 x Cross-head screwdrivers (2) 1 x T-line hex wrench (3)
Nuts and Bolts	 <p>(1) (2) (3) (4) (5) (6)</p>	64 x M8 x 80 mm expansion (1) 10 x M8 x 20 mm (2) 36 x M8 x 12 mm (3) 36 x M6 x 10 mm (4) 6 x M3 x 6 mm (5) 5 x M2.5 x 4 mm (6)

Item	Quantity	Note
Anti-Static Gloves		2 pairs
Remote Control		1 With two AAA batteries
System Control Box Spacer		10





NOTE:

- This product is packed in a wooden crate.
- Due to the size and weight, it is recommended that two or more people handle it.

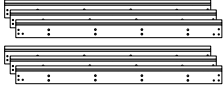
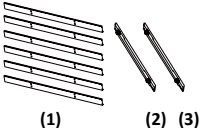
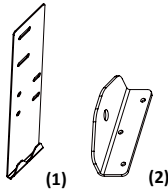

Optional Accessories

The accessories below are for the LED Display with the either hidden or separate System Control Box layout. These accessories are sold separately. If you are not sure of which ones to order, consult your dealer for technical support or product service.

Hidden Installation

	Item	Quantity	Note
Wall Mount Brackets		6	
Screen Bezels		8	6 x Bottom (1) 1 x Bottom Left (2) 1 x Bottom Right (3)
System Control Box Mount Brackets		4	2 x Upper (1) 2 x Lower (2)
Cable Zip Ties		20	
Ethernet Cable		16	3.5 m
Cabinet Power Cables		4	

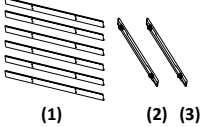
Separate Installation

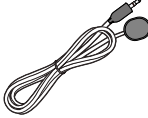
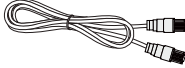
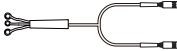
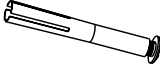
	Item	Quantity	Note
System Control Box Top Cover		2 sides	
Screen Bezels		8	6 x Bottom (1) 1 x Bottom Left (2) 1 x Bottom Right (3)
Cable Zip Ties		20	
IR Extension Cable		1	10 m
Ethernet Cable		16	15 m
Cabinet Power Cables		4	15 m
Fasteners		3 sets	

Product Overview

Front Panel

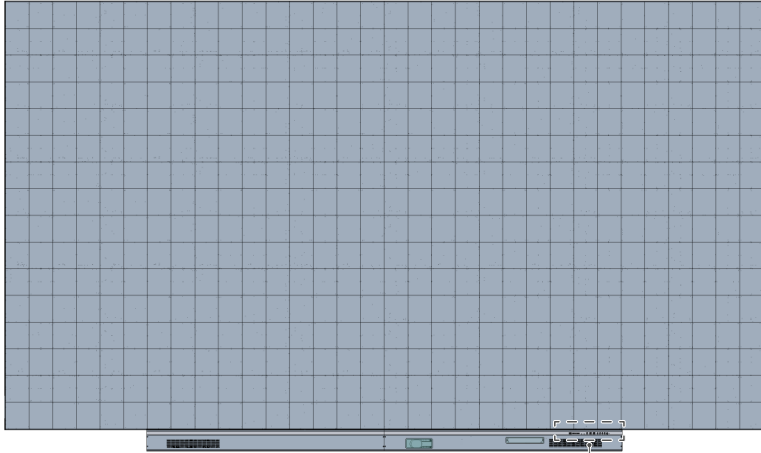

I/O &
Control Panel

Rear Panel

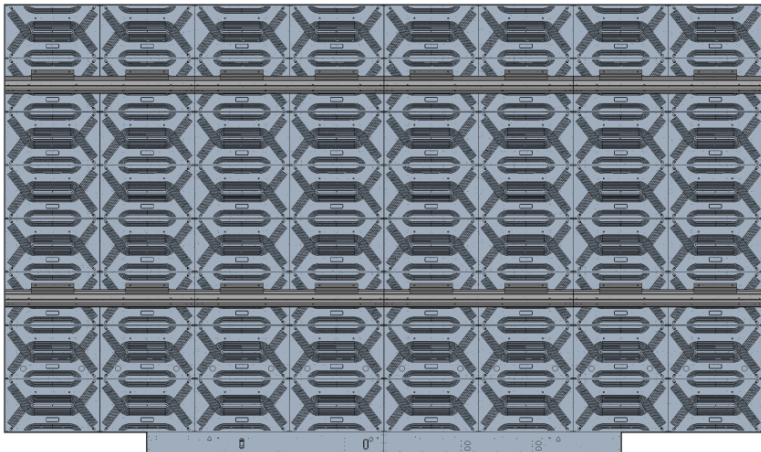

Introduction

The step-by-step instructions in this guide are a general reference for installing the LED Display. If any details in this document are unclear, please contact your reseller for more information.

Ensure your LED Display is installed and grounded properly by a qualified installer or serviceperson.

About the LED Display

ViewSonic Direct View LDP217-121C is designed to be installed on the wall only. However, the System Control Box can be mounted in three different ways.

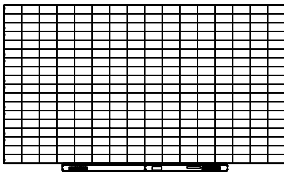

Under the Cabinets
(Standard Installation)

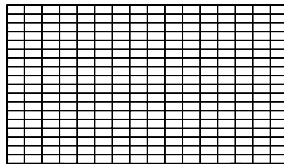

Behind the Cabinets
(Hidden Installation)

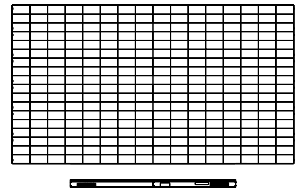

Apart from the Cabinets
(Separate Installation)

Before Installing

Read these instructions carefully, keep them in a safe place, and follow all warnings and instructions.

General Safety Precautions

- Ensure there is no direct airflow from air conditioning or heating vents blowing on the LED Display.
- Always wear protective gear, such as gloves and protective shoes, when handling the LED Display.
- Electrical connections, and all associated servicing or adjusting, should only be performed by a qualified electrician approved or licensed as required by the locality.

Installation

- Avoid installing the LED Display in places with high humidity.
- Ensure that the wall can safely support 360 kg and the power outlet supplies enough voltage (max: 3449W; normal: 1150W).
- Ensure the deviation of the wall surface is < 5 mm.
- Wood may split if holes are not pre-drilled before installing the Wall Mount Brackets.

System Control Box Power Cable Safety

- Due to high power usage, always use the power cord(s) specifically designed for this product.
- Do not damage or modify the Power Cable(s).
- Do not use extension cords. If the Power Cable(s) are too short, have a qualified electrician install an outlet near the LED Display.

Wall Mounting (Standard Installation)

Eight Wall Mount Brackets are used for mounting the screen to the wall.

Installing the Wall Mount Brackets

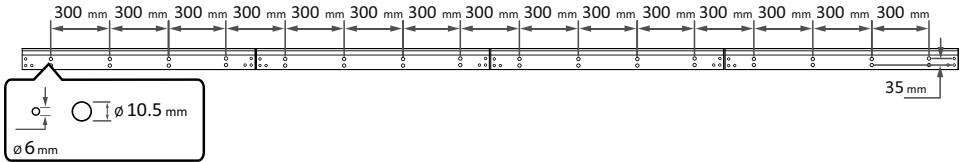

1. Ensure the wall area is an appropriate installation site.
NOTE: Refer to page 14 for more information.
2. Using the illustration as shown above as a guide, mark at least 16 mounting holes and pre-drill them.
NOTE: To ensure the marks are perfectly horizontal, it is recommended to use a laser or torpedo level.
3. Install the first Upper Wall Mount Bracket with the provided screws (M8 x 80 mm Expansion for masonry; wood screws for load bearing wood).
4. Repeat **Step 3** for the second Upper Wall Mount Bracket.
5. After mounting the first and second Upper Wall Mount Brackets to the wall, secure them with the Wall Mount Connector Plate using the six provided screws (M6 x 10 mm).

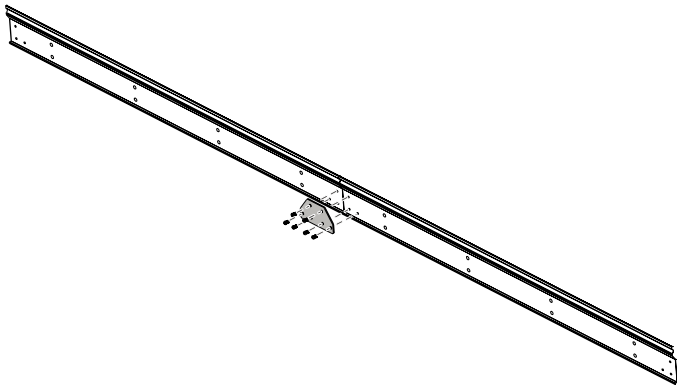

6. Repeat **Step 3~5** for the other two Upper Wall Mount Brackets.

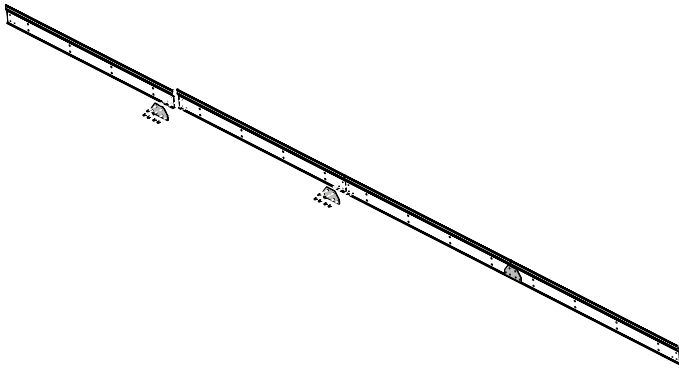

7. Install the Lower Wall Mount Brackets in the same manner as the Upper Wall Mount Brackets. The distance between the Upper and Lower Wall Mount Brackets is 1350 mm.
8. After installing both Upper and Lower Wall Mount Brackets, the installation wall should look like:

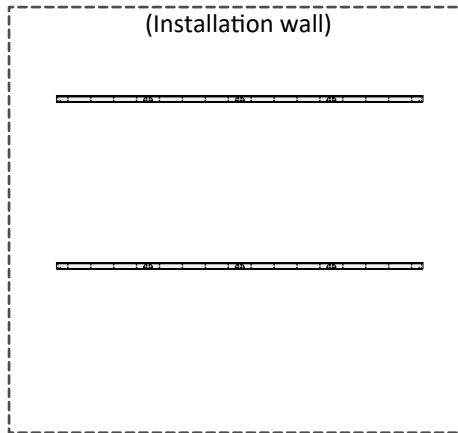

After the Wall Mount Brackets are installed, please go to page 19 for the Cabinets (Standard Installation).

Spacing Instructions for Wall Installation (Standard Installation)

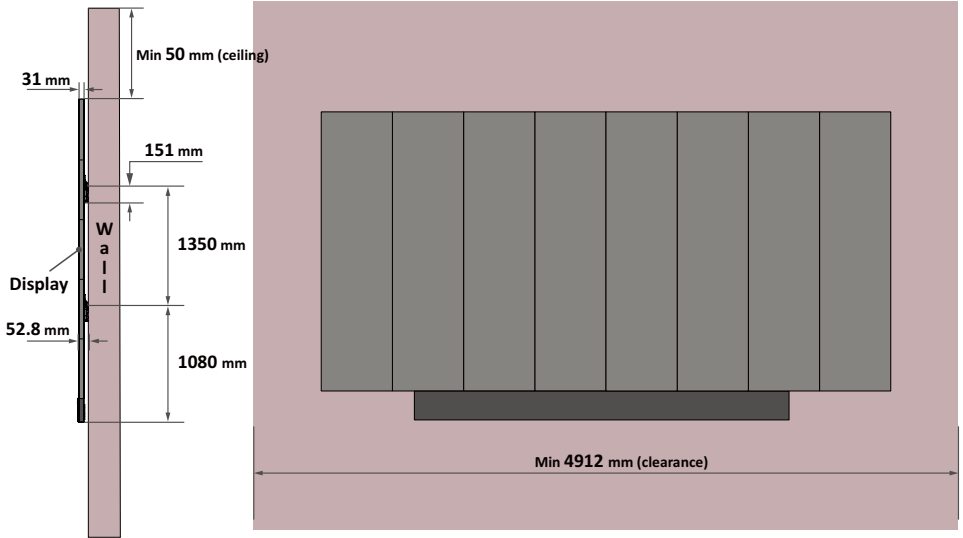

NOTE:

- You can also install the Upper Wall Mount Brackets, hang the screen, and then install the Lower Wall Mount Brackets for a more precise fit.
- Adjustment in floor clearance and ceiling height should be made according to the actual installation site.

Wall Mounting (Hidden Installation)

When the System Control Box is installed behind the Cabinets, this installation type requires a different set of Wall Mount Brackets. You also need the System Control Box Mount Brackets to attach the System Control Box to the rear of the Cabinets.

Wall Mounting

Six Wall Mount Brackets are used for mounting the screen to the wall.

Installing the Upper and Lower Wall Mount Brackets

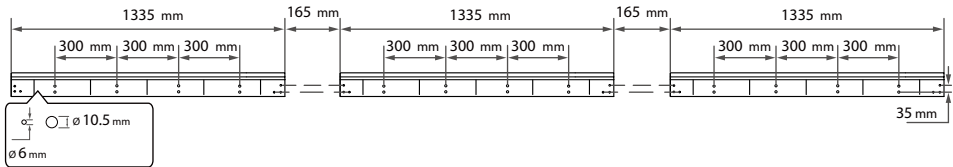

1. Ensure the wall area is an appropriate installation site.
NOTE: Refer to page 16 for more information.
2. Using the illustration as shown above as a guide, mark at least 12 mounting holes and pre-drill them.
NOTE: To ensure the marks are perfectly horizontal, it is recommended to use a laser or torpedo level.
3. Install the first Upper Wall Mount Bracket with the provided screws (M8 x 80 mm Expansion for masonry; wood screws for load bearing wood).
4. Repeat **Step 3** for the second and third Upper Wall Mount Brackets.
5. Install the Lower Wall Mount Brackets in the same manner as the Upper Wall Mount Brackets. The distance between the Upper and Lower Wall Mount Brackets is 1350 mm.

6. After installing both Upper and Lower Wall Mount Brackets, the installation wall should look like:

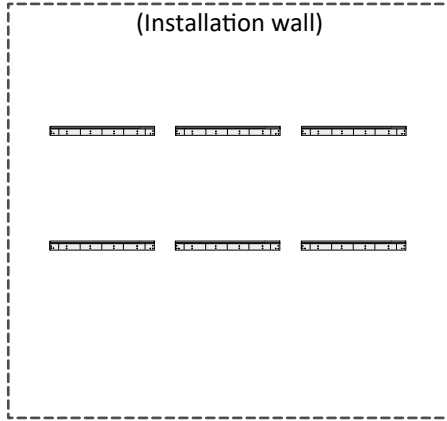

After the Wall Mount Brackets are installed, please go to page 24 for the Cabinets (Hidden Installation).

Spacing Instructions for Wall Installation (Hidden Installation)

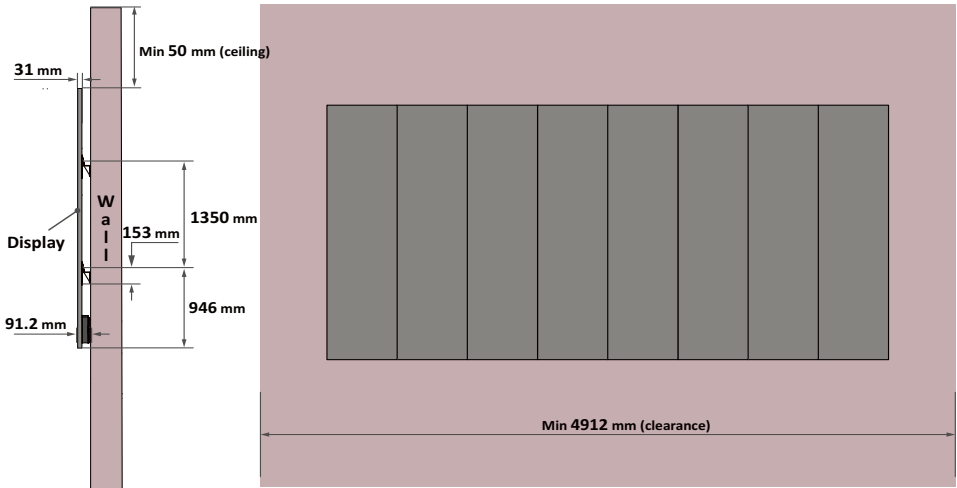

NOTE:

- You can also install the Upper Wall Mount Brackets, hang the screen, and then install the Lower Wall Mount Brackets for a more precise fit.
- Adjustment in floor clearance and ceiling height should be made according to the actual installation site.

Wall Mounting (Separate Installation)

When the System Control Box is installed apart from the Cabinets, this installation type uses the same Wall Mount Brackets as the Standard Installation. However, you will need to pre-drill additional holes for the System Control Box.

Drill Hole Spacing for System Control Box

❗ Ensure there is enough space between the mounting holes and cable access holes.

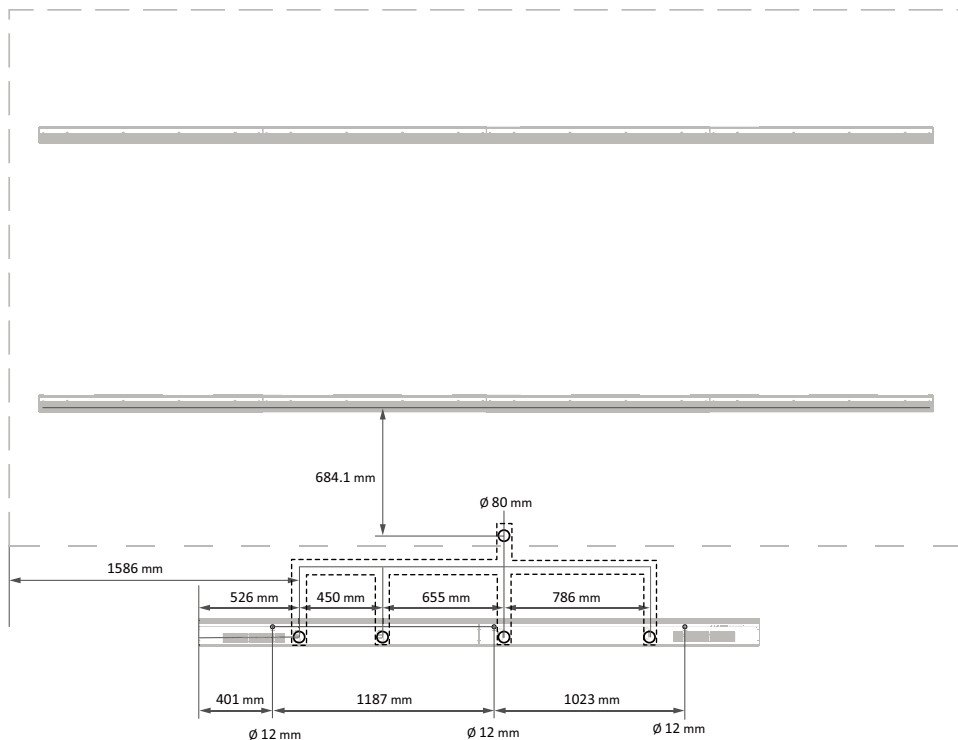

1. Please follow **Step 1~7** on page 12~13 for the Upper and Lower Wall Mount Brackets.

NOTE: To ensure the wall area is suitable for installation, refer to page 18 for more details.

2. Use the illustration as shown above as a guide to mark the following holes and pre-drill them.
 - At least three mounting holes for the System Control Box.
 - Four cable access holes, one at the top and three at the bottom. The cable access holes at the bottom should be positioned relative to the holes provided in the System Control Box.

After the Wall Mount Brackets are installed, please go to page 24 for the Cabinets (Separate Installation).

Spacing Instructions for Wall Installation (Separate Installation)

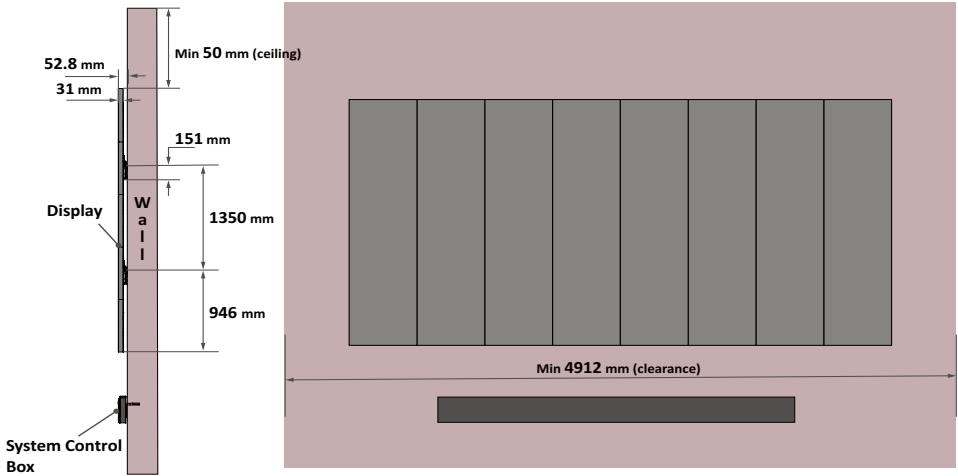

NOTE:

- You can also install the Upper Wall Mount Brackets, hang the screen, and then install the Lower Wall Mount Brackets for a more precise fit.
- Adjustment in floor clearance and ceiling height should be made according to the actual installation site.

Installing the Cabinets (Standard Installation)

1. Place the Upper Cabinet section "D-1" and Lower Cabinet section "D-2" on stable furniture that can safely support the two Cabinet sections.

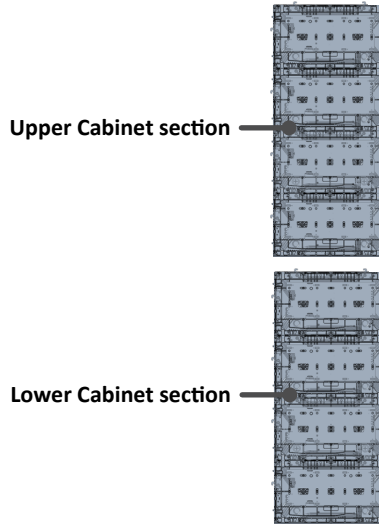

NOTE:

- One Cabinet is separated into two sections. Each Cabinet section weighs around 15.2 kg.
- You can identify Cabinets by the labels (-1 for Upper and -2 for Lower) on the package and Cabinets.
- The arrow marks should be pointing down.

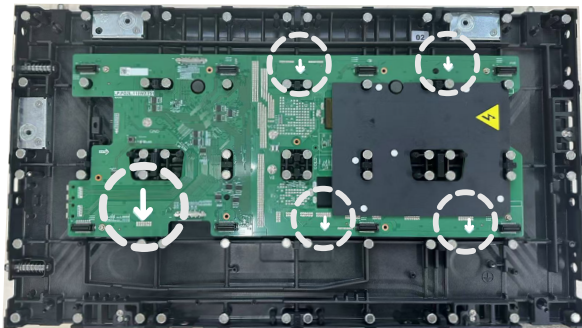

2. Push each locking hook with the provided wrench to connect the two sections of Cabinet "D" together.

NOTE: There are two locking hooks between each section.

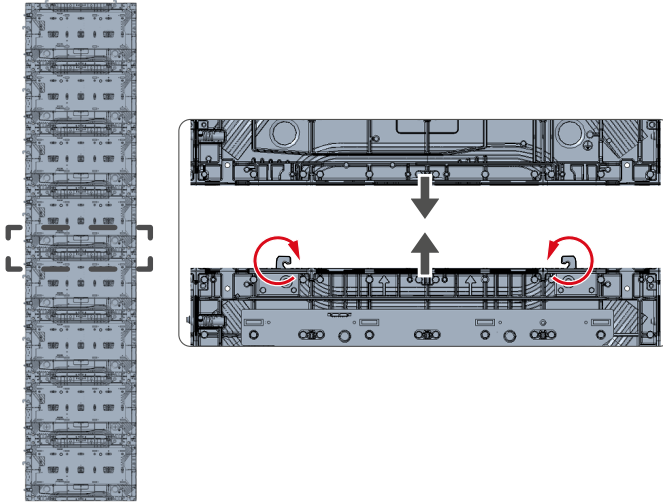

3. Further secure the two Cabinet sections with the Locking Plate and two provided screws (M8 x 12 mm).

NOTE: There are two Locking Plates and four screws between each Cabinet section.

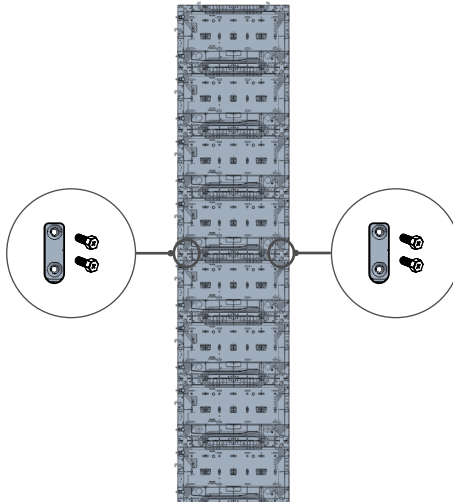

- Carefully lift the assembled Cabinet "D" onto the center of the Upper Wall Mount Brackets.

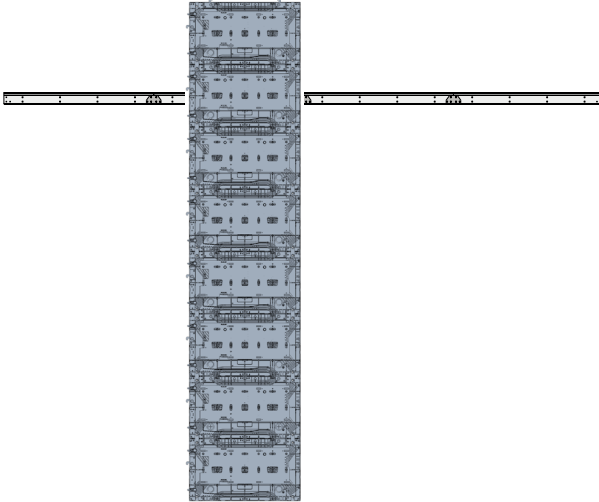

- Ensure the Mounting Brackets sit securely on the Wall Mount Brackets as shown below.

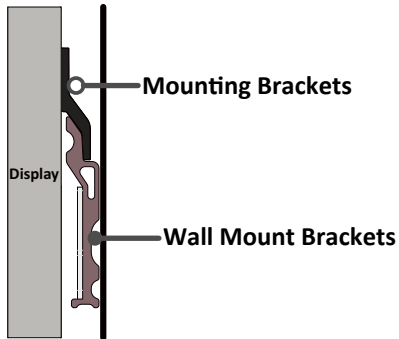

- Repeat **Step 1~3** for Cabinet "E".

7. Lift the assembled Cabinet "E" and install it on the right side of Cabinet "D". Push each locking hook with the provided wrench to securely connect the two Cabinets together.

NOTE: There are eight locking hooks between each Cabinet.

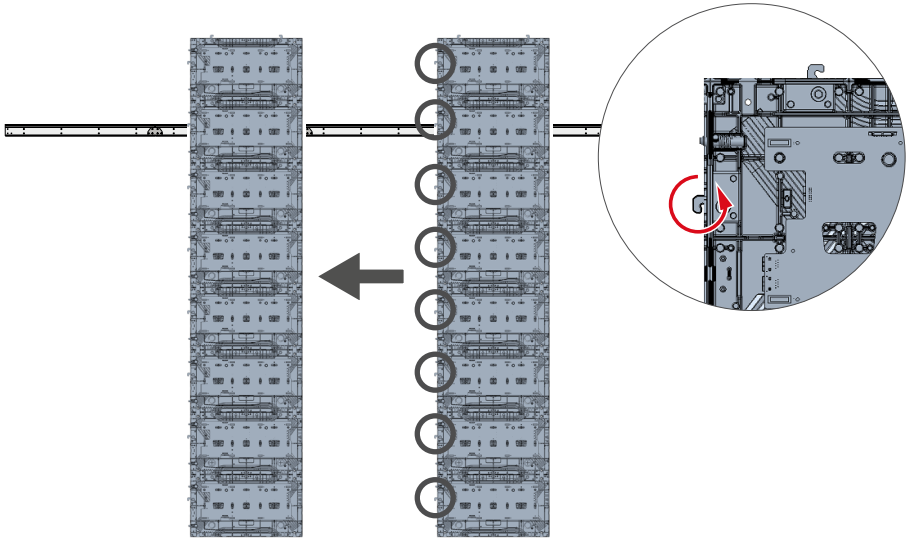

8. Check for unevenness of the Cabinets by rubbing the cross section between each Cabinet. If the cross section is not aligned, loosen the locking hook slightly and tap the Cabinets until the cross section is flat.

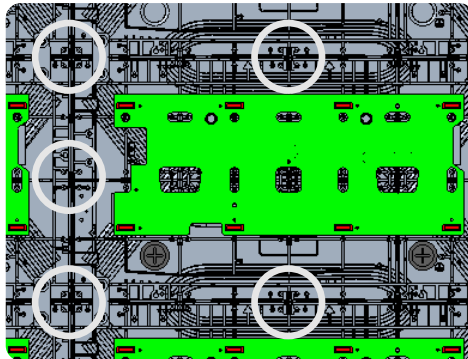

9. Repeat **Step 1~8** for the remaining Cabinets. Install from the center to the right and left sides of the Wall Mount Brackets.

NOTE: The installation sequence by Cabinet: D → E → C → F → B → G → A → H

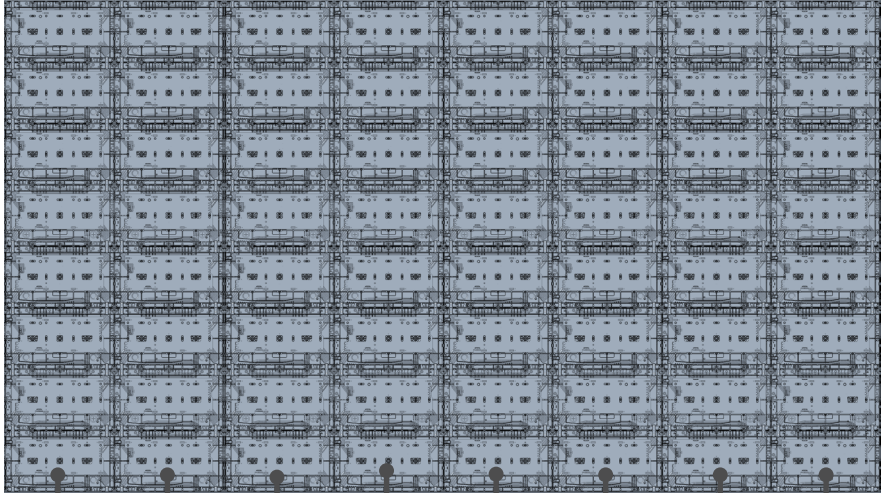

Cabinet A Cabinet B Cabinet C Cabinet D Cabinet E Cabinet F Cabinet G Cabinet H

After all Cabinets are installed, please go to page 31 for the System Control Box (Standard Installation).

Installing the Cabinets (Hidden Installation)

1. Prepare the following two items.

- 4 x Power Cables.
- 16 x Network Cables.

NOTE: Ensure the Cables prepared are of the correct length for your installation type.

2. Please follow **Step 1~3** on page 19 ~20 for Cabinets. Ensure the furniture used can safely support eight Cabinets or 245 kg.

3. Cut the rubber hole plugs installed on the second row of the Cabinets to size along the cross. The rubber hole plugs are used to protect the cables from rubbing against any pointed edges.

NOTE: The rubber hole plugs must always be placed in the holes.

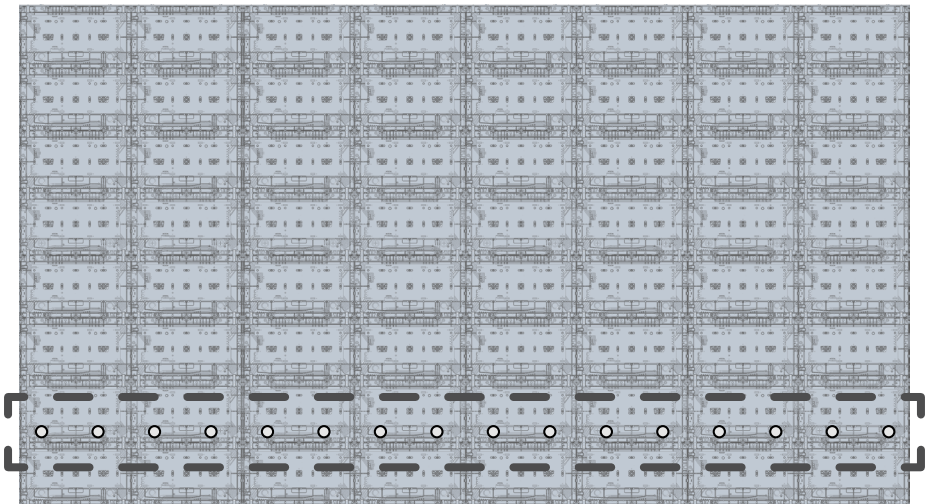

4. Place Cabinet "C" and Cabinet "E" facing down. Then, install the Upper System Control Box Mount Brackets to the side of the two Cabinets as shown below using the provided screws (M8 x 20 mm).

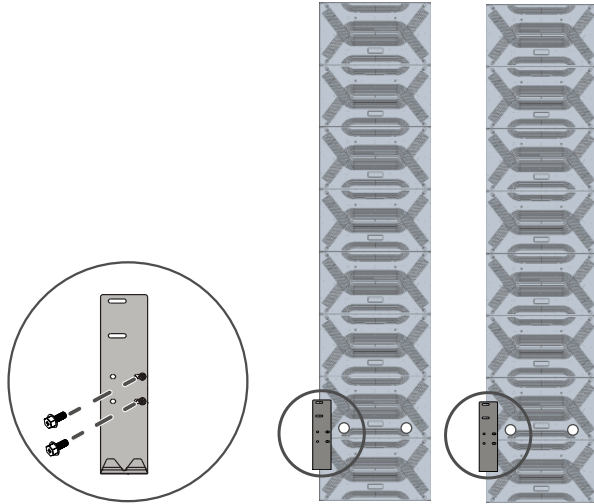

Rear View of Cabinet "C" (right) and Cabinet "E" (left)

5. Please follow **Step 4~9** on page 21~23 for Cabinet "C", Cabinet "D", Cabinet "E" and Cabinet "F". Set the other Cabinets aside ("A", "B", "G", and "H").

NOTE: Ensure the Mounting Brackets sit securely on the Wall Mount Brackets as shown below.

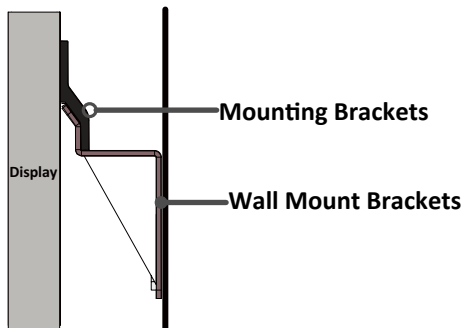

6. Follow the image below or the labels on the Power and Network Cables to thread them to the rear of the Cabinets.

NOTE: Avoid sharp bends or twists in the Cables.

- Thread the hardwire end of the Power Cable through the hole on every two Cabinets (Cabinet "D" and Cabinet "F"). Set the remaining Power Cables aside.
- Thread one end of the Network Cable of each Cabinet through the hole on the Cabinet to the rear. Ensure the corresponding letters on the Cables are matched to the Cabinets (C-1 and C-2 to C, D-1 and D-2 to D, and so on). Set the remaining Network Cables aside.

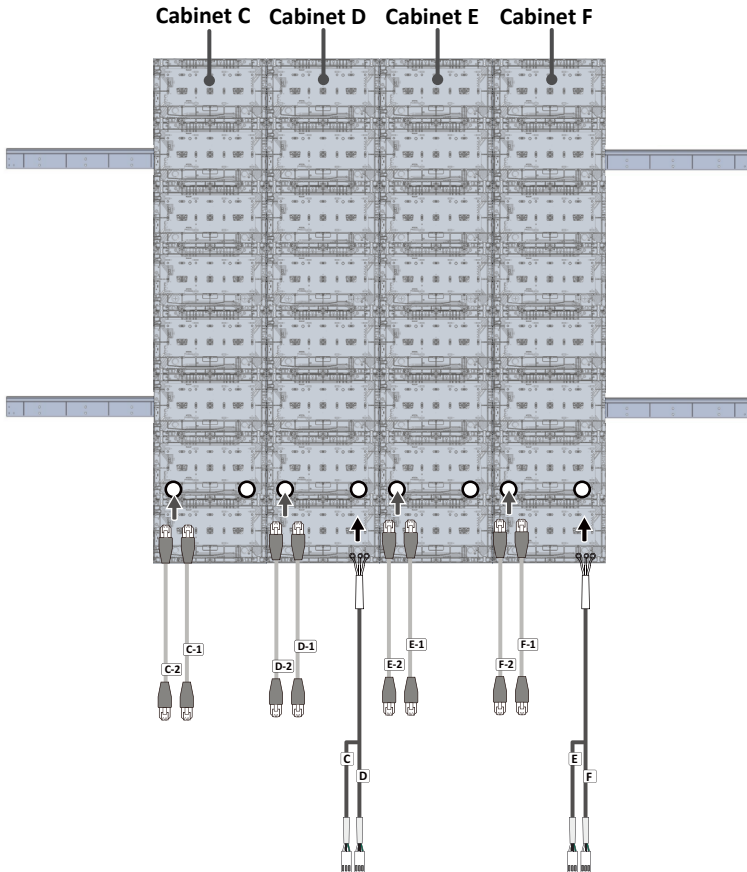

After the Cabinets are installed, please go to page 39 for the System Control Box (Hidden Installation).

Installing the Cabinets (Separate Installation)

1. Prepare the following two items.

- 4 x Power Cables.
- 16 x Network Cables.

NOTE: Ensure the Cables prepared are of the correct length for your installation type.

2. Please follow **Step 1~3** page 19~20 for Cabinets. Then, place each assembled Cabinet facing down on the furniture.

NOTE: Ensure the furniture used can safely support eight Cabinets or 245 kg.

3. Cut the rubber hole plugs installed on the second row of the Cabinets to size along the cross. The rubber hole plugs are used to protect the cables from rubbing against any pointed edges.

NOTE: The rubber hole plugs must always be placed in the holes.

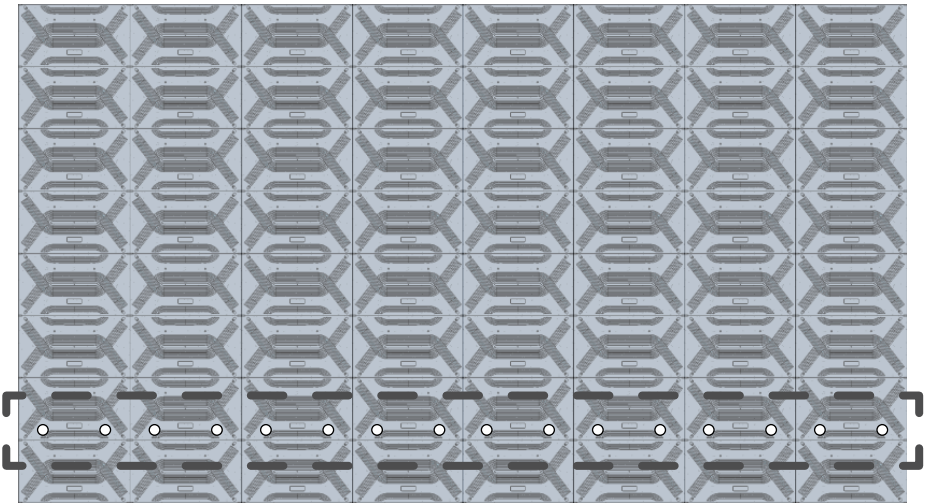

Rear View of the Cabinets

4. Follow the image below or the labels on the Power and Network Cables to thread them from behind the Cabinets to the front.

NOTE: Avoid sharp bends or twists in the Cables.

- Thread the connector end of the Power Cable fully through the hole on every two Cabinets (Cabinet "B", "D", "F", and "H"), leaving only the hardwire end behind.
- Thread one end of the Network Cable of each Cabinet through the hole on the Cabinet to the front. Ensure the corresponding letters on the Cables are matched to the Cabinets (A-1 and A-2 to A, B-1 and B-2 to B, and so on).

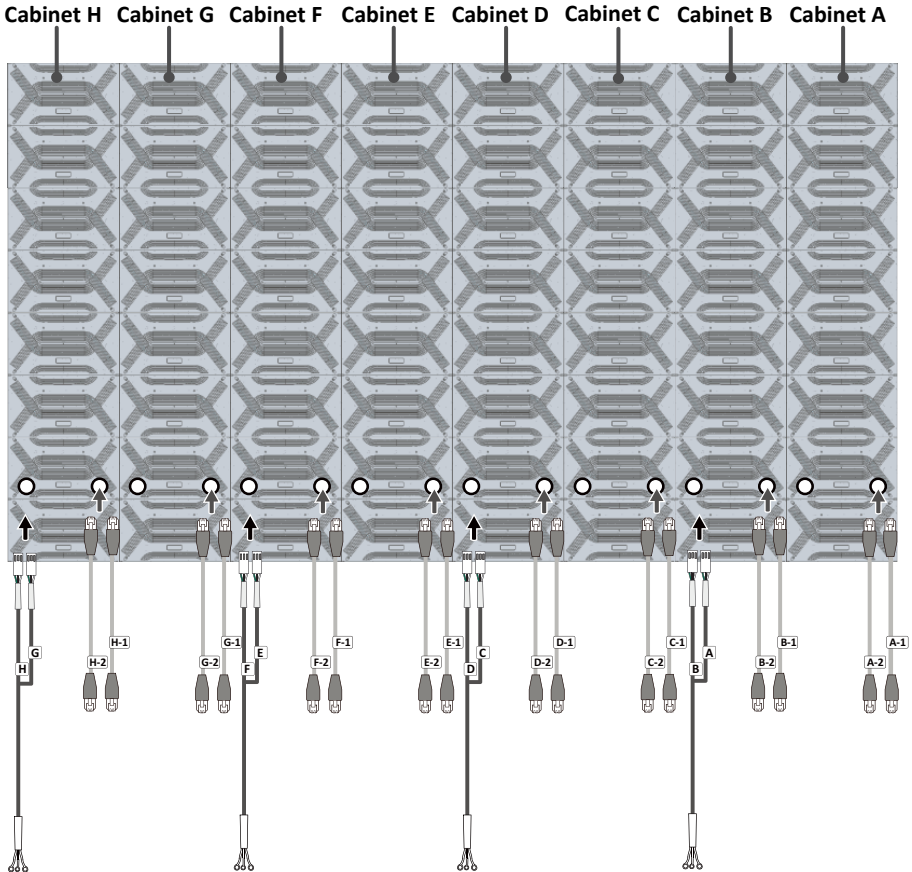

5. Carefully lift the assembled Cabinet "D" onto the center of the Upper Wall Mount Brackets, ensuring the Mounting Brackets sit securely on the Wall Mount Brackets.
6. Carefully thread the Power Cable of the Cabinets behind the Cabinets from the top cable access hole through the bottom cable access hole on the left.

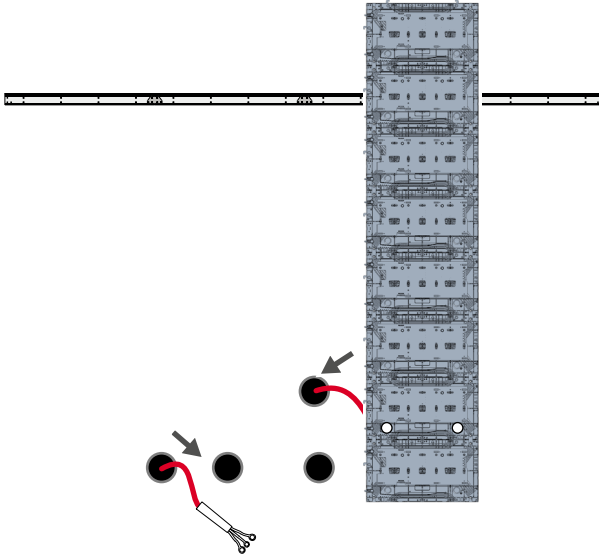

7. Carefully thread the other end of the Network Cable of the Cabinet "D" in the same manner as the Power Cable, but run the Network Cable through the bottom cable access hole on the right instead.

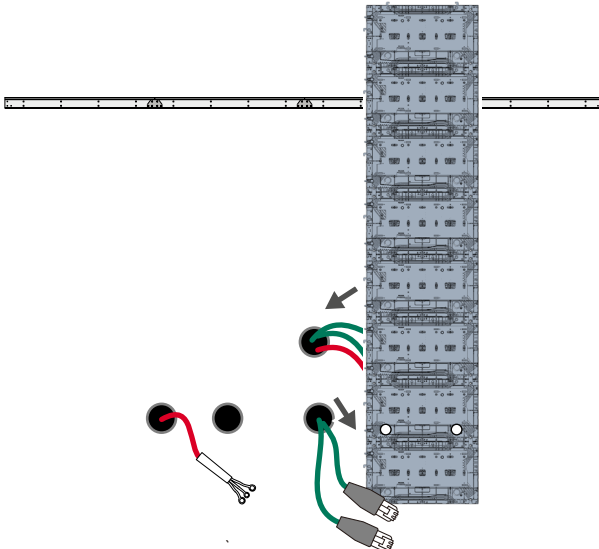

8. Please follow **Step 4~9** on page 21~23 for the other Cabinets and thread the Power (only applicable to Cabinet "B", Cabinet "F", and Cabinet "H") and Network Cables through the appropriate bottom cable access holes in the same manner as Cabinet "D".

NOTE:

- There are four Power and 16 Network (two per one Cabinet) Cables to thread.
- The installation sequence by Cabinet: D → E → C → F → B → G → A → H

After all Cabinets are installed, please go to page 46 for the System Control Box (Separate Installation).

Connecting the System Control Box (Standard Installation)

The left and right sides of the System Control Box are pre-installed with its Covers in the factory. The main system control board is on the right.

- ❗ The safety wires are used to prevent the Right Cover from falling when accessing the System Control Box. Please ensure that the safety wires are never removed.
- ❗ Use caution as the System Control Box panel is separated into two pieces with wires attached.

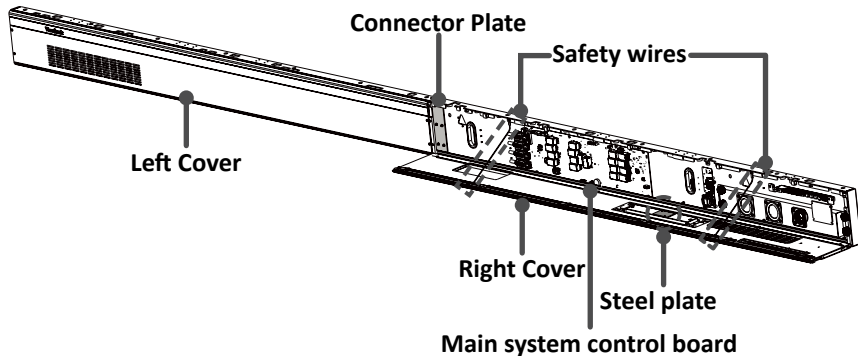

1. Carefully place the System Control Box on stable furniture that can safely support the System Control Box.
2. To open the Right Cover, slowly bring the supplied System Control Box Maintenance Tool near the surface of the Right Cover where the steel plate is located. Then, the Right Cover should detach from the System Control Box magnetically.

- ❗ DO NOT try to remove or disconnect the safety wires. Please ensure that the safety wires are never removed.

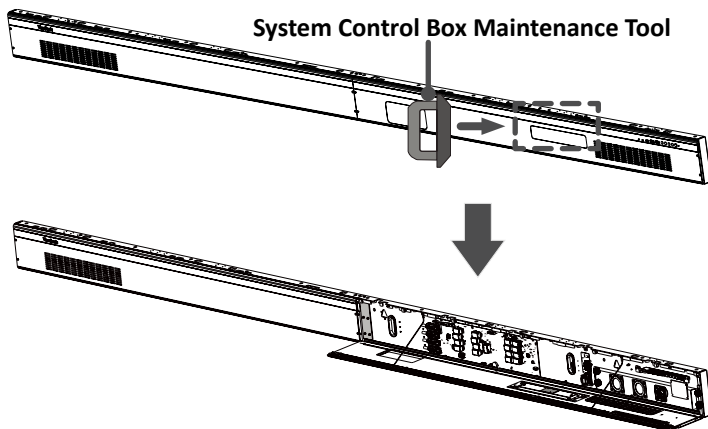

3. Remove the Left Cover by gripping the top edge of the Cover and pulling it toward you. The Left Cover should simply lift away.

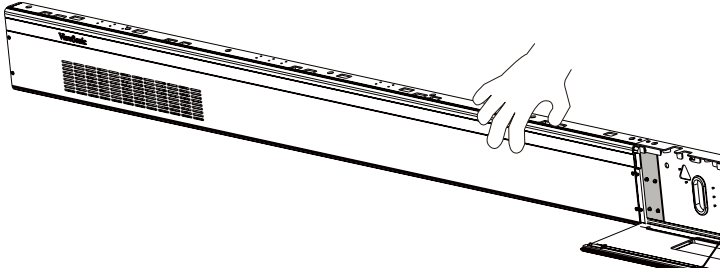

4. Secure the System Control Box panel with the Connector Plate using the provided screws (M3 x 6 mm).

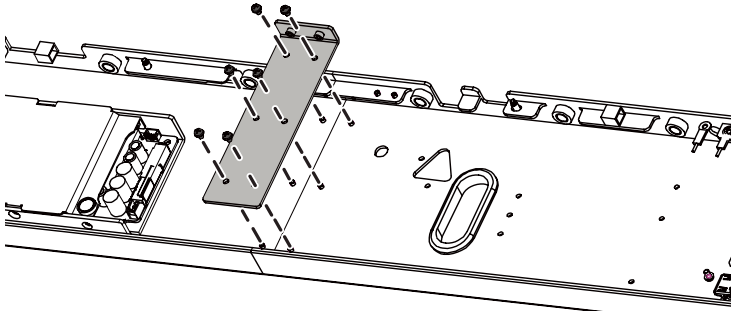

5. Further secure the Connector Plate with the two provided screws (M3 x 6 mm).

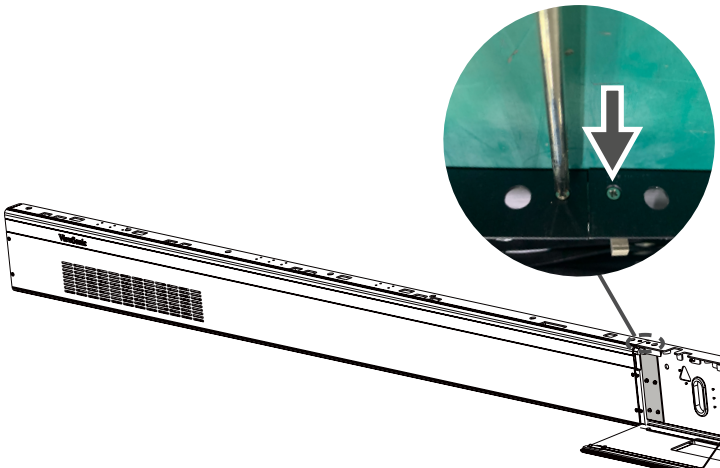

- Align the holes of the Cabinets with the System Control Box to attach.
- Carefully route the Power and Network Cables through the holes in each Cabinet.

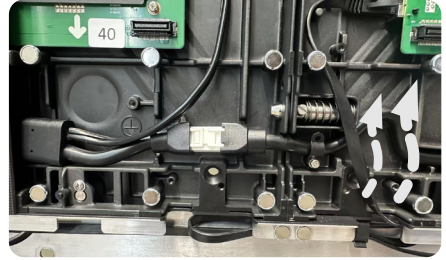
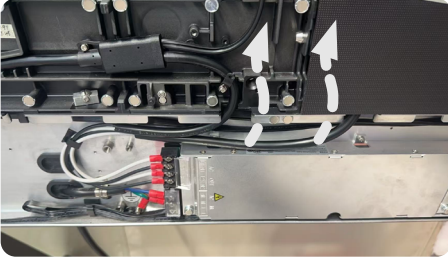

- Install the System Control Box to the bottom of the Cabinets with the provided screws (M8 x 20 mm).

NOTE: There are 10 threaded holes between the Cabinets and the System Control Box.

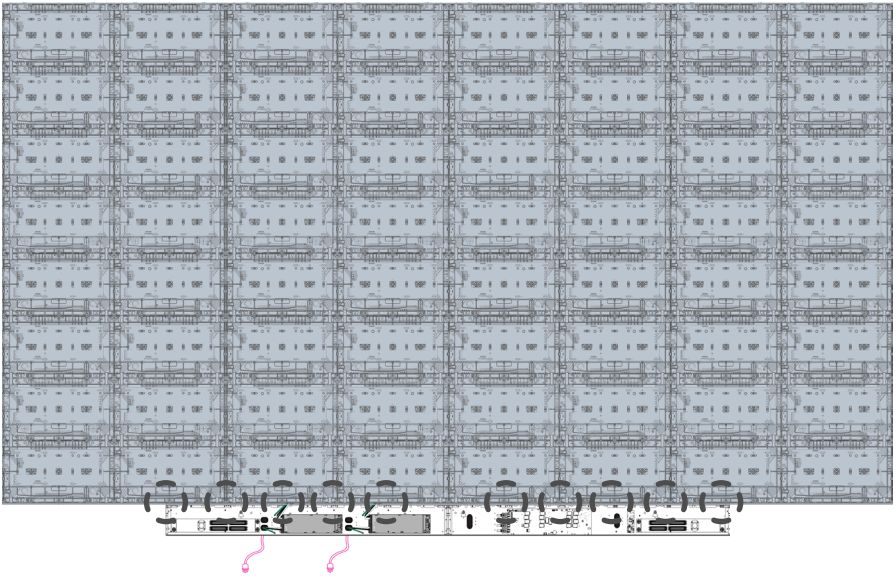

9. Slide a System Control Box Spacer on the M8 screw as shown below. Then, secure the Spacer with the provided screw (M3 x 8 mm) to connect the System Control Box with the Cabinets firmly.

NOTE: There are 10 System Control Box Spacers to install.

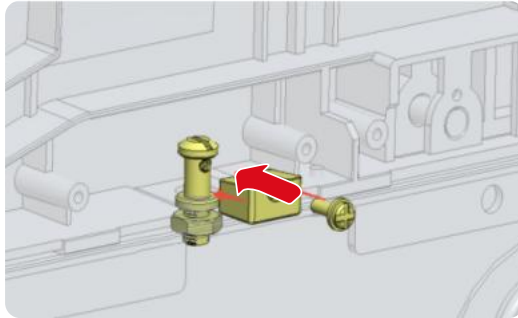

10. Connect the Network Cables from the System Control Box to each Cabinet. Ensure the corresponding letters on the Cables are matched to the Cabinets (A-1 and A-2 to A, B-1 and B-2 to B, C-1 and C-2 to C, and so on).

NOTE:

- There are 16 Network Cables (two per one Cabinet) to connect.
- Ensure the Network Cables labeled with "-1" connected to the fourth row of the Cabinets, while the Cables labeled with "-2" to the eighth row.

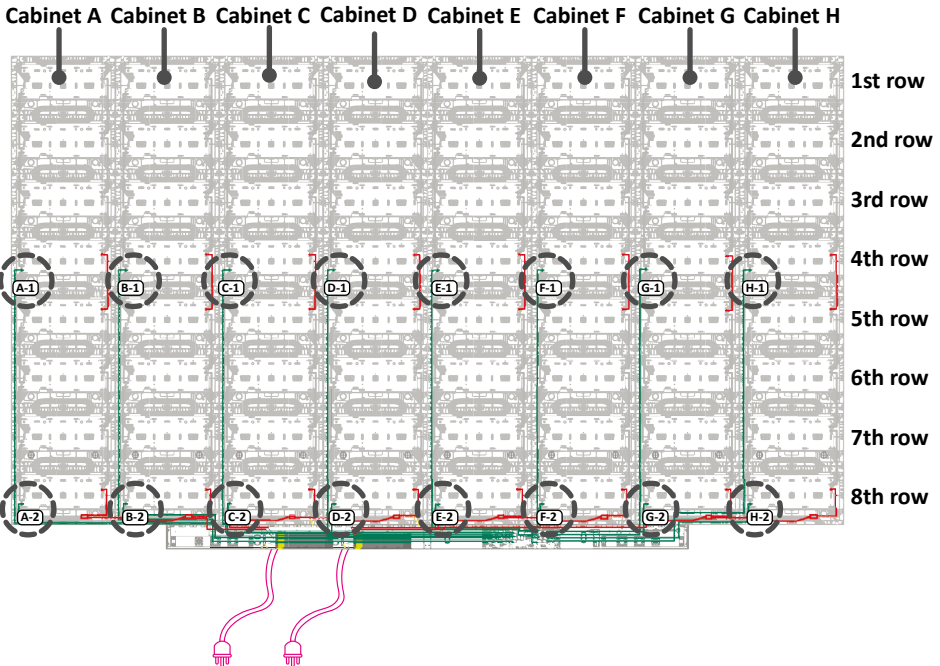

11. Connect the Power Cables between the Upper and Lower Cabinet sections and from the System Control Box to each Cabinet. Ensure the corresponding letters on the Cables are matched to the Cabinets (A to A, B to B, C to C, and so on).

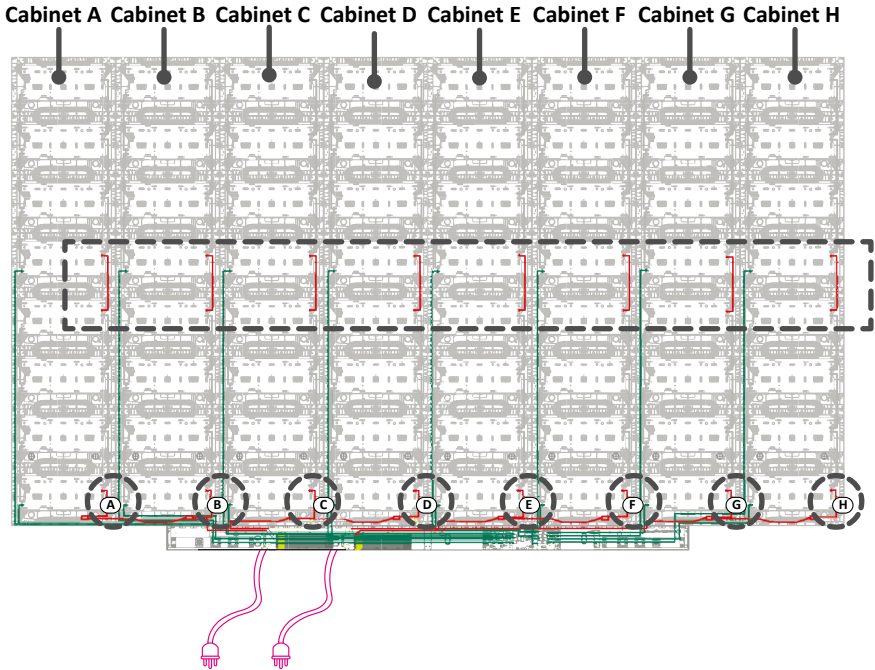

12. Connect the left system control board to the main system control board.

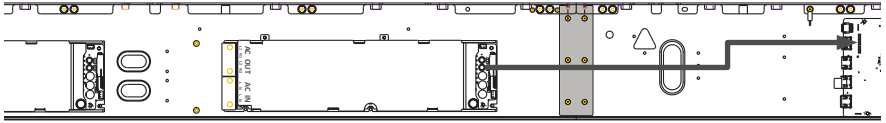

13. Connect the LED Display's left speaker to the Audio Out port of the system control board.



NOTE: Ensure the right speaker is properly connected to the other Audio Out port.

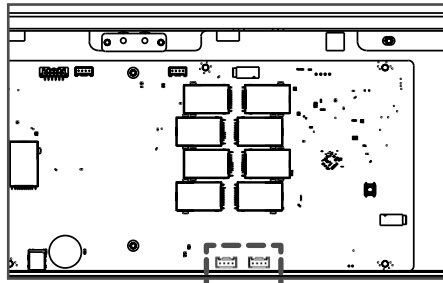

Audio Out ports

14. Ensure the two AC units of the System Control Box is properly connected.

! DO NOT connect the System Control Box Power Cables at this time.

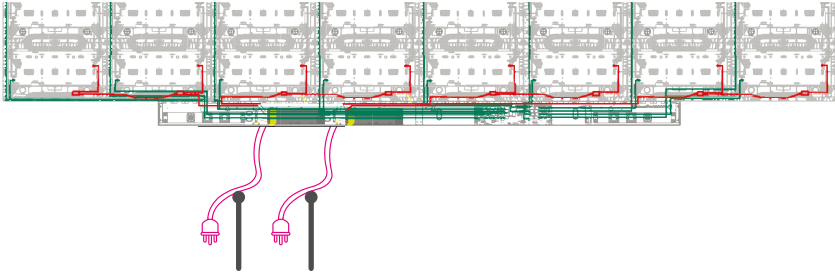

System Control Box Power Cables

- The neutral wires (usually white/blue) are connected to the "N1", "N2", and "N" terminals.
- The hot wires (usually black/brown) are connected to the "L1", "L2", and "L" terminals.
- The input and output terminals are properly grounded (2 x AC OUT and 1 x AC IN, usually green-yellow/green).

! The meaning of wiring color may vary by country.

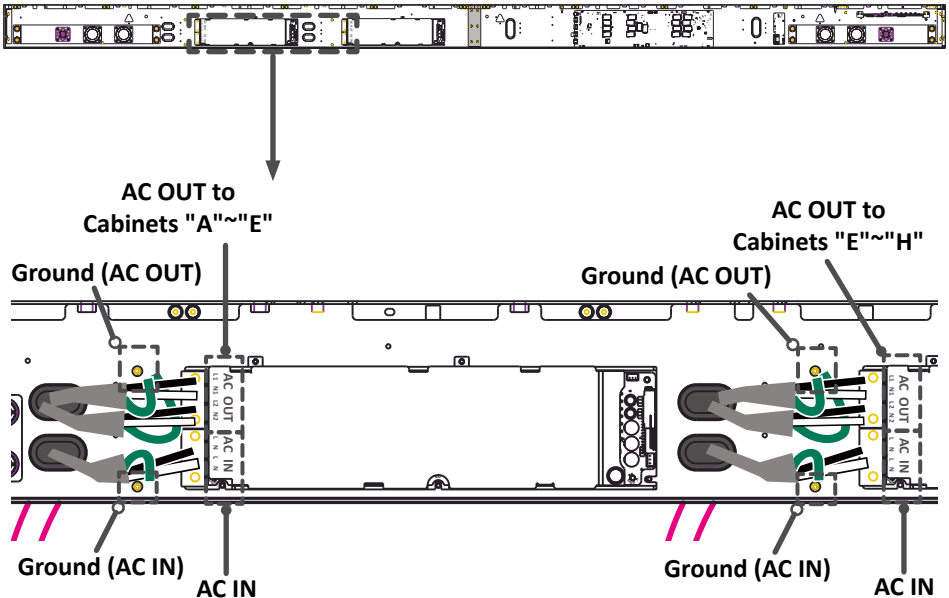

15. Locate and route the System Control Box's ground wire (usually in green-yellow/green) through the hole and into the Cabinet. Then, remove the pre-installed screw on the rod as shown below, connect the ground wires to the rod, and properly secure the wire with the screw.

NOTE: There are two System Control Box's ground wires to install.

Ground wires

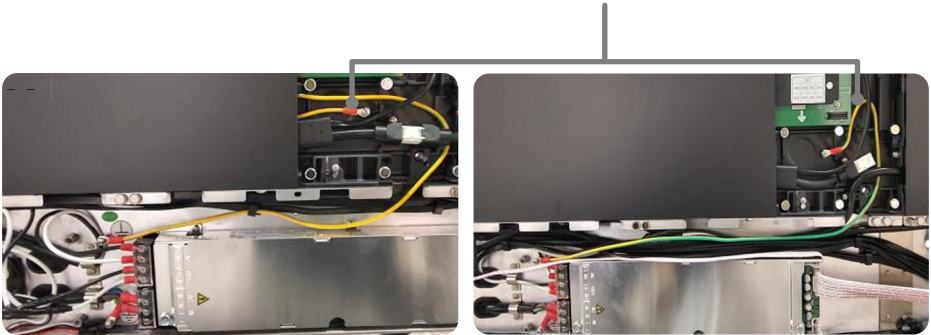

16. After connecting all cables and wires, hold the top edge of the Right Cover toward the System Control Box to replace it. Once the Right Cover is replaced, it will be held in place magnetically.

NOTE: Ensure the **Power** Button cable is connected before securing the Right Cover.

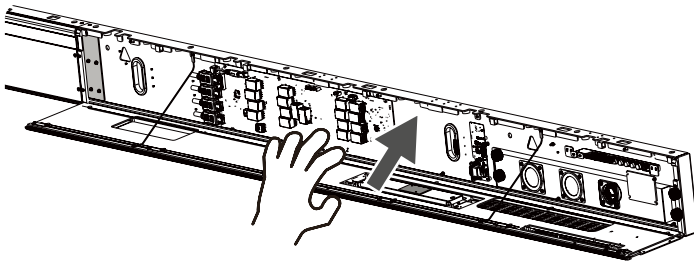

17. Replace the Left Cover by aligning it properly with the System Control Box; then the Left Cover should attach magnetically.

After the System Control Box is connected, please go to page 49 for the LED Modules.

Connecting the System Control Box (Hidden Installation)

The left and right sides of the System Control Box are pre-installed with its Covers in the factory. The main system control board is on the right.

- ❗ The safety wires are used to prevent the Right Cover from falling when accessing the System Control Box. Please ensure that the safety wires are never removed.
 - ❗ Use caution as the System Control Box panel is separated into two pieces with wires attached.
1. Please follow **Step 1~5** on page 31~32 for the System Control Box and the Connector Plate.
 - ❗ DO NOT try to remove or disconnect the safety wires. Please ensure that the safety wires are never removed.
 2. Install the short side of the Lower System Control Box Mount Bracket onto the top of the System Control Box with the provided screws (M3 x 6 mm).

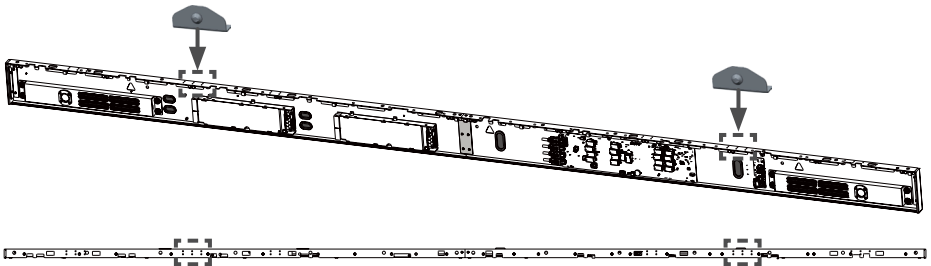

Installing the Lower System Control Box Mount Brackets onto the System Control Box (Front and Top Views)

3. Install the provided screw (M8 x 16 mm) on the Lower System Control Box Mount Bracket. Thread the provided M8 nut onto the screw and fully tighten the nut.

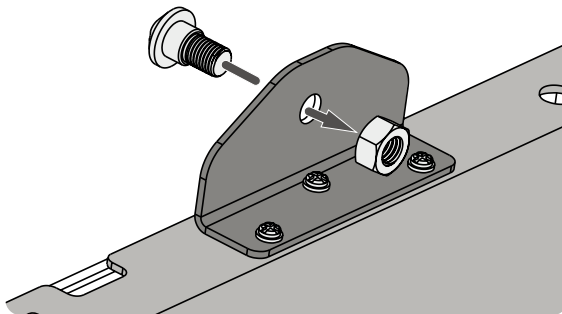

Installing the provided screw and nut to the Brackets (Rear View)

4. Repeat **Step 2~3** for the other Lower System Control Box Bracket.

5. Prepare the rubber hole plugs installed on the System Control Box by cutting the hole to size along the cross. The rubber hole plugs are used to protect the Cables from rubbing against any pointed edges.

NOTE: The rubber hole plugs must always be placed in the holes.

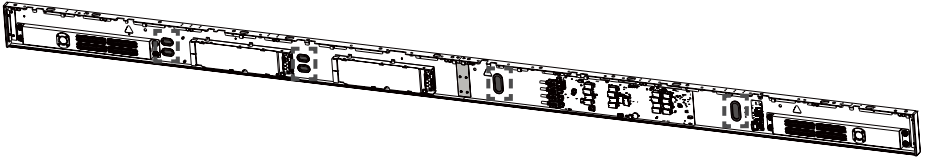

6. Remove the pre-installed Power and Network Cables of the Cabinets from the System Control Box.

NOTE:

- There are four Power and 16 Network Cables to remove.
- It is recommended to take photos of the completed wiring in the left and main system control boards before removing the Cables.

7. Carefully thread the Power and Network Cables through the holes provided in the System Control Box from behind. You may need to bring the System Control Box closer to the Cabinets.

NOTE:

- Ensure to use the correct cable holes for the Power and Network Cables.
- As you thread the new Cables, it is recommended to follow the existing pathways to keep everything organized.
- There are four Power and 16 Network Cables to thread.

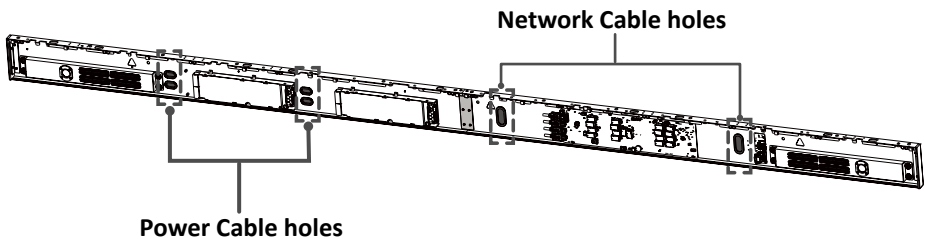

8. Connect one end of the Network Cable to the network port that was disconnected from the System Control Box in **Step 6**.

NOTE: There are 16 Network Cables to connect.

9. Follow the diagram below to connect the Power Cables of the Cabinets to the two AC units of the System Control Box.

❗ DO NOT connect the System Control Box Power Cable at this time.

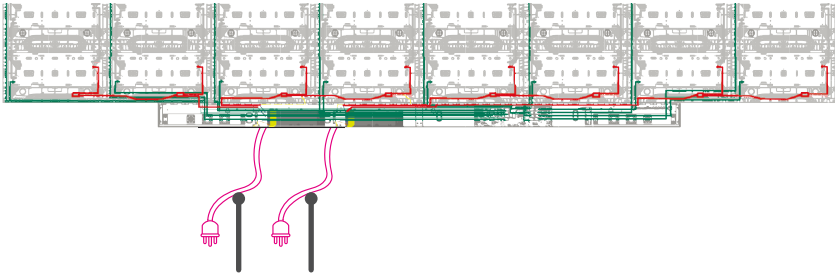

System Control Box Power Cables

- Connect the neutral wires (usually white/blue) to the "N1" and "N2" terminals.
 - Connect the hot wires (usually black/brown) to the "L1" and "L2" terminals.
 - Connect the ground wires (usually in green-yellow/green) to the ground terminals.
- ❗ The meaning of wiring color may vary by country.
- ❗ Use the provided wrench to tighten the neutral, hot, and ground conductors in the terminals properly.
- ❗ The Power Cable must be properly grounded. Follow the electrical codes in your area if additional grounding is required.

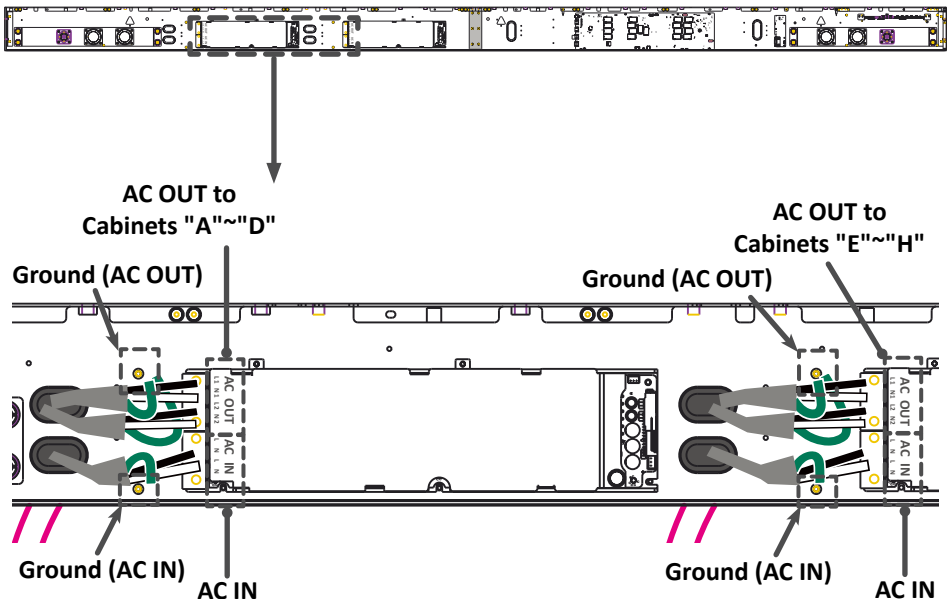

10. Remove the two System Control Box's ground wires (usually in green-yellow/green).

Ground wires

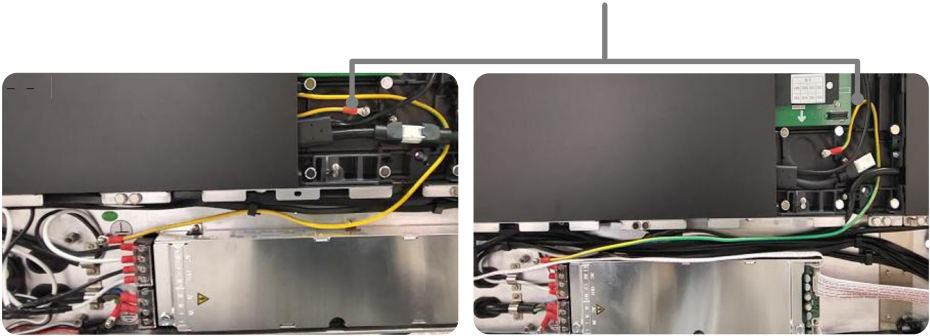

11. Please follow **Step 12~13** on page 36 for the system control board.

NOTE: After the IR Extension Cable is connected, route it through the adjacent cable hole as highlighted below to the rear.

Connection port
for IR Extension Cable

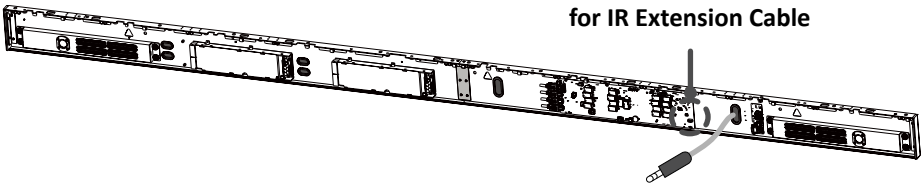

12. After connecting all Cables and wires, please follow **Step 16~17** on page 37 for the System Control Box Covers.

NOTE: Please ensure there are no sharp bends or twists in the Cables and wires.

13. Align the Lower System Control Box Mount Brackets with the Upper Mount Brackets to attach.

14. Carefully place the Lower System Control Box Mount Brackets onto the Upper System Control Box Mount Brackets.

NOTE: To avoid sharp bends or twists in the Cables, please pull them into the Cabinets and manage the Cables there.

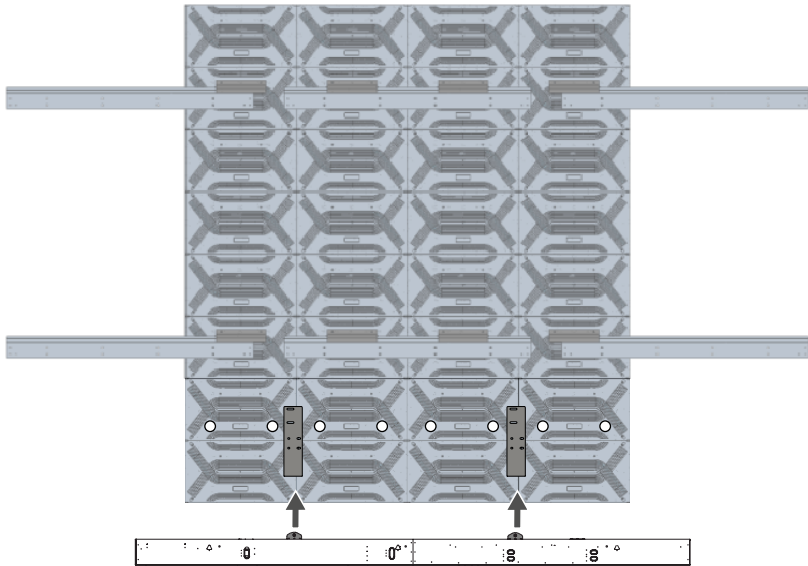

Placing the Lower System Control Box Mount Bracket onto the Upper (Rear View)

15. Ensure the Lower System Control Box Mount Brackets sit securely on the Upper.

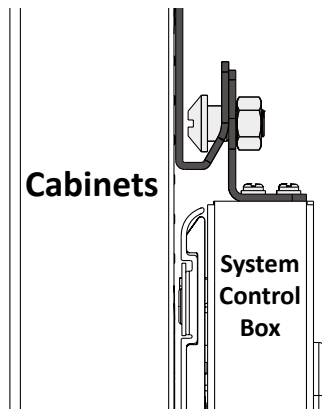

16. Please follow **Step 4~9** on page 21~23 for Cabinet "B".

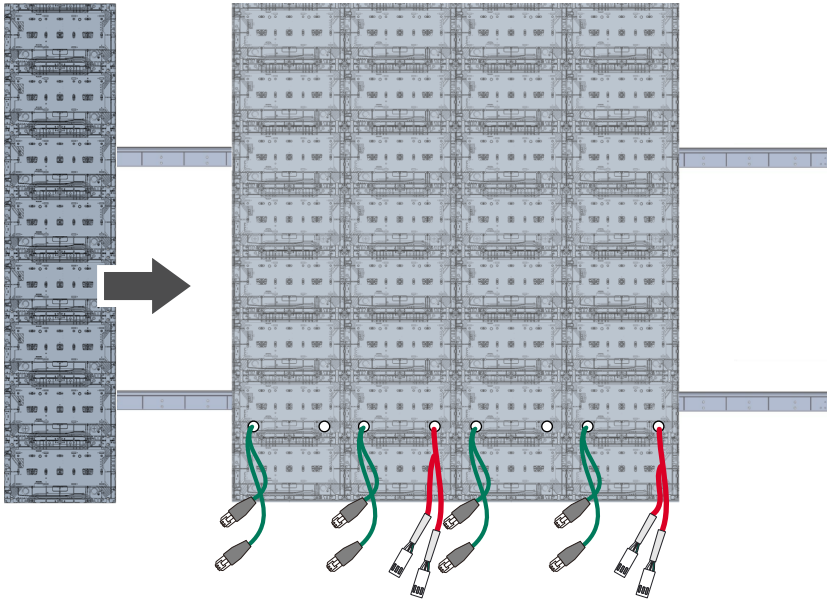

17. Thread the other end of the Power Cables of Cabinet "A" and Cabinet "B" and Network Cables of Cabinet "B" through the hole at the second row of the Cabinet "B" from behind to the front.

NOTE: There are one Power and two Network Cabinet to thread.

18. Install the remaining Cabinets and thread the Power (only applicable to Cabinet "H") and Network Cables for the remaining Cabinets in the same manner as Cabinet "B". Start from the middle and move to the left and right.

NOTE: There are one Power and six Network Cables (two per one Cabinet) to thread.

19. Connect the Power and Network Cables of the Cabinets.

- Connect the Power Cables between the Upper and Lower Cabinet sections and from the System Control Box to each Cabinet.
- Install the Power Cable's ground wire (usually in green-yellow/green) on a rod provided in the Cabinet with the provided screw (M3 x 6 mm). The route of the ground wire should be as short as possible.
- Connect the Network Cables labeled with "-1" connected to the fourth row of the Cabinets, while the Cables labeled with "-2" to the eighth row.

NOTE:

- There are eight ground wires, 16 Power Cables, and 16 Network Cables to connect.
- Ensure the corresponding letters on the Cables are matched to the Cabinets (A to A, B to B, C to C, and so on).

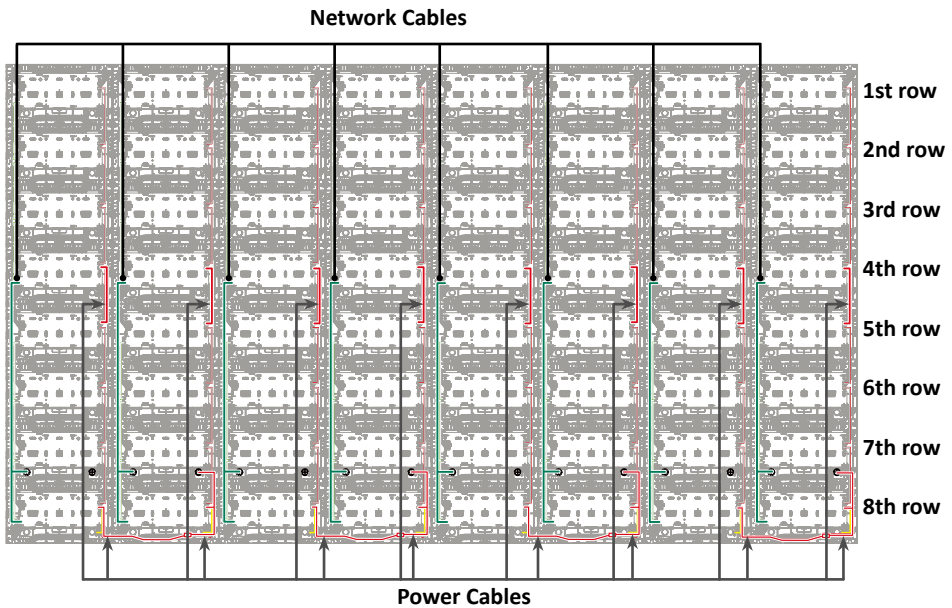

After the System Control Box is connected, please go to page 49 for the LED Modules.

Connecting the System Control Box (Separate Installation)

The left and right sides of the System Control Box are pre-installed with its Covers in the factory. The main system control board is on the right.

- ❗ The safety wires are used to prevent the Right Cover from falling when accessing the System Control Box. Please ensure that the safety wires are never removed.
- ❗ Use caution as the System Control Box panel is separated into two pieces with wires attached.

1. Please follow **Step 1~5** on page 31~32 for the System Control Box and the Connector Plate.
 - ❗ DO NOT try to remove or disconnect the safety wires. Please ensure that the safety wires are never removed.
2. Prepare the rubber hole plugs installed on the System Control Box by cutting the hole to size along the cross. The rubber hole plugs are used to protect the Cables from rubbing against any pointed edges.
3. Place the System Control Box accordingly over the drilled mounting holes to attach.
4. Carefully thread the Power and Network Cables through the holes provided in the System Control Box from behind.

NOTE:

- Ensure to use the correct cable holes for the Power and Network Cables.
- As you thread the new Cables, it is recommended to follow the existing pathways to keep everything organized.
- There are four Power and 16 Network Cables to thread.

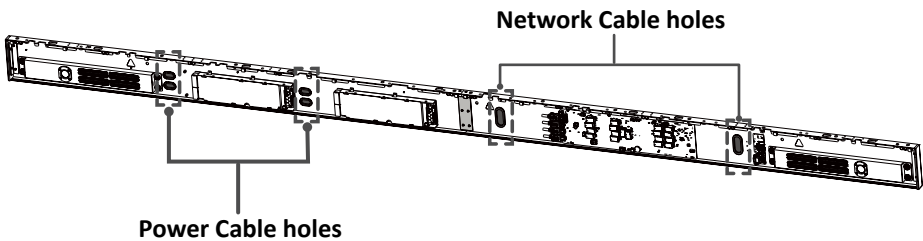

5. After threading the Power and Network Cables, install the System Control Box onto the wall with the provided screws (M8 x 80 mm Expansion for masonry; wood screws for load bearing wood).

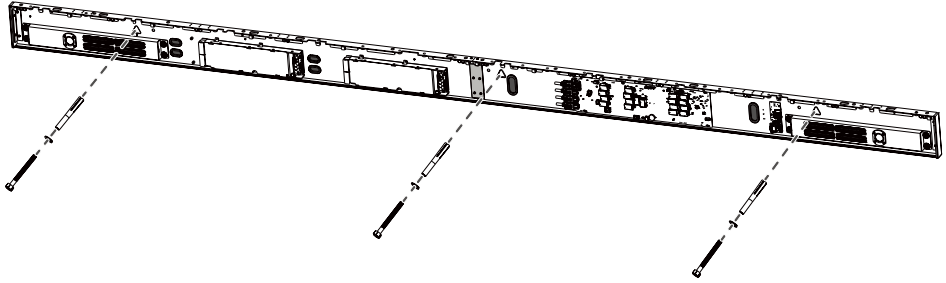

6. Remove the pre-installed Power and Network Cables of the Cabinets from the System Control Box.

NOTE:

- There are four Power and 16 Network Cables to remove.
- It is recommended to take photos of the completed wiring in the left and main system control boards before removing the Cables.

7. After removing the pre-installed Power and Network Cables of the Cabinets, connect the other end of the Network Cables to the network port that was disconnected from the System Control Box in **Step 6**.

NOTE: There are 16 Network Cables to connect.

8. Please follow **Step 12~13** on page 36 for the system control board.

NOTE: After the IR Extension Cable is connected, route it through the adjacent cable hole as highlighted below to the rear.

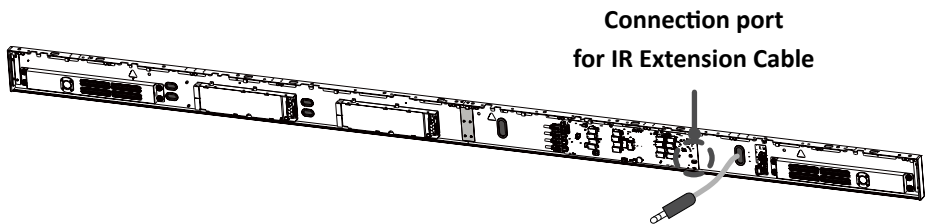

9. Remove the two System Control Box's ground wires (usually in green-yellow/green).

Ground wires

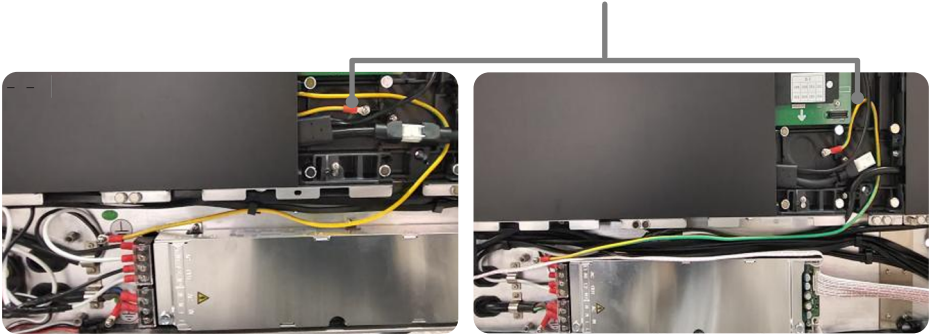

10. Please follow **Step 19** on page 44 for the Power and Network Cables on the Cabinets.

11. After connecting all cables and wires, please follow **Step 16~17** on page 38 for the System Control Box Covers.

⚠ Ensure there are no sharp bends or twists in the Cables and wires.

After the System Control Box is connected, please go to page 49 for the LED Modules.

Installing the LED Modules

- ❗ Please wear Anti-Static Gloves before handling the LED Modules.
- ❗ To avoid direct contact with the LED Modules, please remove watches, rings, bracelets, or other metal objects.
- ❗ Use caution when installing the LED Modules.

1. Starting from the LED Module labeled "1" in the top left corner, align each LED Module with the Cabinet, then carefully press the Module into place.

NOTE: The arrow mark on the back of the LED Modules should be pointing down.



2. Attach the remaining LED Modules onto the Cabinets. Install from top left and move to bottom right, ensuring to match the corresponding numbers on the Module to the Cabinet.

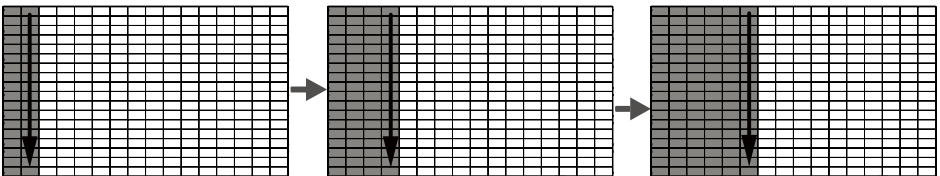

NOTE: Before installing the LED Module, ensure that each Module is flush and that there is little to no gap between each. It may be necessary to gently tap the module to make it flush.

After all LED Modules are installed, please go to page 50 (Standard Installation) or page 52 (Hidden and Separate Installation) for the Screen Bezels.

Installing the Screen Bezels (Standard Installation)

- ! The Screen Bezels' plastic tabs are pre-installed onto the Bezels. Ensure all plastic tabs are properly mounted before installing the Screen Bezels onto the screen.

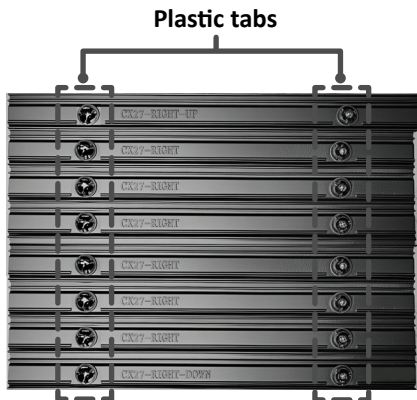

1. Place the Screen Bezels to the correct side of the screen to attach. It is easier to start with the top Bezels first then put on the sides. The top Screen Bezels (left and right) are around 2 mm longer than the others.

NOTE:

- Each Screen Bezel is marked, so you'll know which side to install.
 - If a Screen Bezel does not seem to fit, lift it up with caution and check if it is on the correct side to install. If the Bezel does not seem to fit at all, please contact your dealer. DO NOT force it into place.
2. Align the plastic tabs of the Screen Bezel with the holes provided in the screen.

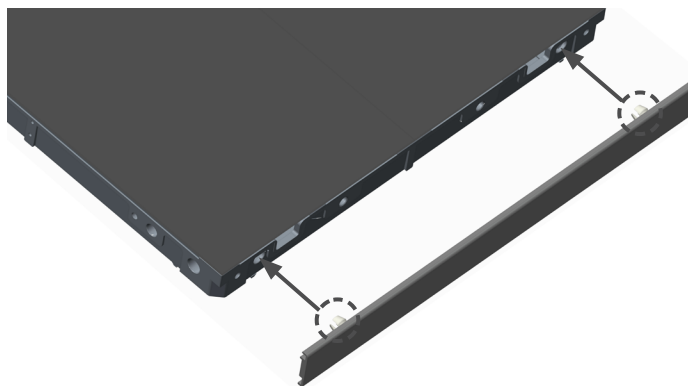

3. Press down on the Screen Bezel until you hear it click into place.
4. Place the remaining Screen Bezels onto the left and right sides of the screen.

NOTE: There are eight Screen Bezels on either left or right side of the screen to install.

After all Screen Bezels are installed, please go to page 54 to finish the installation.

Installing the Screen Bezels (Hidden and Separate Installation)

- ❗ The Screen Bezels' plastic tabs are pre-installed onto the Bezels. Ensure all plastic tabs are properly mounted before installing the Screen Bezels onto the screen.

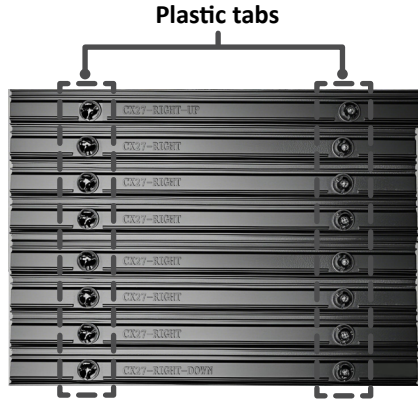

1. Please follow **Step 1~4** on page 50 for the left and right sides of the Screen Bezels.

NOTE:

- Each Screen Bezel is marked, so you'll know which side to install.
- If a Screen Bezel does not seem to fit, lift it up with caution and check if it is on the correct side to install. If the Bezel does not seem to fit at all, please contact your dealer. **DO NOT** force it into place.

2. At the bottom of the screen, loosen the screws securing the pre-installed Screen Bezel and remove it. This provides enough room to the bottom Screen Bezels.

NOTE: There are two pre-installed Screen Bezels to remove.

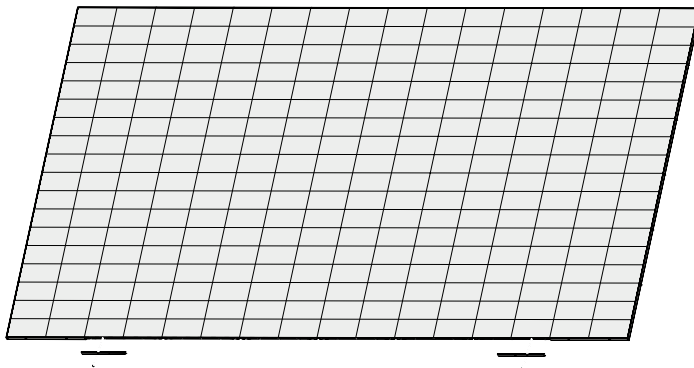

3. Install the bottom Screen Bezel to the screen with the four provided screws (M3 x 10 mm).

NOTE: There are eight bottom Screen Bezels to install.

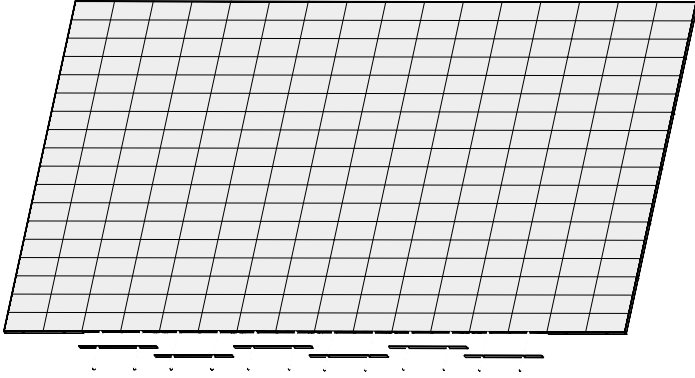

After all Screen Bezels are installed, please go to page 54 to finish the installation.

Turning On the LED Display

1. Make sure the System Control Box Power Cable is connected and plugged into a power outlet.

NOTE: When the System Control Box Power Cable is connected to a power outlet, the Power Indicator Light will be a steady red. This means the LED Display is in standby mode. Please refer to the User Guide for more details.



2. Your LED Display is now ready to power on.



ViewSonic®