



# **NVIDIA ConnectX-8 SuperNIC User Manual**

# Table of contents

Introduction	7
Supported Interfaces	15
Pinouts Description	24
Hardware Installation	34
ConnectX-8 PCIe x16 Installation Instructions	47
ConnectX-8 Extension Option (2x PCIe x16) Installation Instructions	52
Driver Installation	61
DOCA-Host for Linux Driver Installation	61
Windows Driver Installation	63
Firmware Upgrade	75
SuperNIC Configurations	77
Setting High-Speed-Port Link Type	77
PCIe Bifurcation Configuration Options	78
Port Splitting Configurations	79
Monitoring	91
Troubleshooting	93
Finding the GUID/MAC on the SuperNIC	96
Specifications	99
PCIe Auxiliary Card Kit	106
Channel Insertion Loss	107
MCIO Harness Pinouts	108
PCIe Auxiliary Kit Technical Specifications	111

General Cooling Recommendations for Partner-Cooled SuperNICs	114
Document Revision History	121

## About This Manual

This User Manual describes NVIDIA® ConnectX®-8 SuperNICs. It provides details as to the interfaces of the board, specifications, required software and firmware for operating the board, and relevant documentation.

## Intended Audience

This manual is intended for the installer and user of these cards. The manual assumes basic familiarity with InfiniBand and Ethernet network and architecture specifications.

## Ordering Part Numbers

Model	NVIDIA SKU	Port Type	Supported Speed	Form Factor	PCIe Express	Socket Direct Extension Option	Crypto	Secure Boot	ET
C8240	900-9X81Q-00CN-ST0	Dual-port QSFP112	InfiniBand: NDR IB (Default) Ethernet: 400GbE	Half-Height, Half-Length (HHHL)	PCIe 6 x16	☐	☐	☐	TE
C8180	900-9X81E-00EX-ST0	Single-cage OSFP	InfiniBand: 800Gbs XDR IB (Default) Ethernet: 2x400GbE	Half-Height, Half-Length (HHHL)	PCIe 6 x16	☐	☐	☐	TE
	900-9X81E-00EX-DT0	Single-cage OSFP	InfiniBand: 800Gbs XDR IB (Default) Ethernet: 2x400GbE	Half-Height, Half-Length (HHHL)	PCIe 6 x16	☐	☐	☐	TE
C8180L Partner Cooled	900-9X81E-00EX-SL0	Single-cage OSFP	InfiniBand: 800Gbs XDR IB (Default) Ethernet: 2x400GbE	Half-Height, Half-Length (HHHL)	PCIe 6 x16	☐	☐	☐	TE

## Technical Support

Customers who purchased NVIDIA products directly from NVIDIA are invited to contact us through the following methods:

- URL: <https://www.nvidia.com> > Support
- E-mail: [enterprisesupport@nvidia.com](mailto:enterprisesupport@nvidia.com)

Customers who purchased NVIDIA Global Support Services, please see your contract for details regarding Technical Support.

Customers who purchased NVIDIA products through an NVIDIA-approved reseller should first seek assistance through their reseller.

## Related Documentation

<a href="#">DOCA-Host</a>	User Manual describing DOCA Host features, performance, band diagnostic, tools content and configuration.
<a href="#">DOCA Documentation</a>	User Manual describing DOCA SDK platform development.
<a href="#">WinOF-2 for Windows Documentation</a>	User Manual describing WinOF-2 features, performance, Ethernet diagnostic, tools content and configuration.
<a href="#">MFT User Manual (NVIDIA Firmware Tools)</a>	User Manual describing the set of MFT firmware management tools for a single node.
<a href="#">InfiniBand Specifications</a>	InfiniBand Architecture Specification Release 1.2.1, Vol 2 - Release 1.4, Vol 2 - Release 1.5 and Vol 1 - Release 1.7.
<a href="#">IEEE Ethernet Specifications</a>	IEEE Std 802.3 Specification
<a href="#">PCI-SIG Specifications</a>	Industry Standard PCI Express Base and Card Electromechanical Specifications.
<a href="#">LinkX Interconnect Solutions</a>	LinkX cables and transceivers are designed to maximize the performance of High-Performance Computing networks, requiring high-bandwidth, low-latency connections between compute nodes and switch nodes. NVIDIA offers one of the industry's most complete line of 25, 100, 200, and 400GbE in Ethernet and EDR, HDR, NDR and XDR including Direct Attach Copper cables (DACs), copper splitter cables, Active Optical Cables (AOCs) and transceivers in a wide range of lengths from 0.5m to 10km. In addition to meeting Ethernet and IBTA standards, NVIDIA tests every product in an end-to-end environment ensuring a Bit Error Rate of less than 1E-15 .
NVIDIA ConnectX-8 Electrical and Thermal Specifications	You can access the "NVIDIA ConnectX-8 SuperNIC Product Specifications" document either by logging into NVOnline or by contacting your NVIDIA representative.

When discussing memory sizes, MB and MBytes are used in this document to mean size in MegaBytes. The use of Mb or Mbits (small b) indicates size in MegaBits. IB is used in this document to mean InfiniBand. In this document, PCIe is used to mean PCI Express.

## **Revision History**

A list of the changes made to this document is provided in [Document Revision History](#).

---

# Introduction

## Product Overview

The NVIDIA® ConnectX®-8 SuperNIC™ is optimized to supercharge hyperscale AI computing workloads. With support for both InfiniBand and Ethernet networking at up to 800 gigabits per second (Gb/s), ConnectX-8 SuperNIC delivers high-speed, efficient network connectivity, significantly enhancing system performance for AI factories and cloud data center environments.

## Powerful Networking for Generative AI

Central to NVIDIA's AI networking portfolio, ConnectX-8 SuperNICs fuel the next wave of innovation in forming accelerated, massive-scale AI compute fabrics. They seamlessly integrate with next-gen NVIDIA networking platforms, providing end-

to-end 800Gb/s connectivity. These platforms offer the robustness, feature sets, and scalability required for trillion-parameter GPU computing and generative AI applications.

With enhanced power efficiency, ConnectX-8 SuperNICs support the creation of sustainable AI data centers operating hundreds of thousands of GPUs, ensuring a future-ready infrastructure for AI advancements.

ConnectX-8 SuperNICs enable advanced routing and telemetry-based congestion control capabilities, achieving the highest network performance and peak AI workload efficiency. Additionally, ConnectX-8 InfiniBand SuperNICs extend the

capabilities of NVIDIA® Scalable Hierarchical Aggregation and Reduction Protocol (SHARP)™ to boost In-network computing in high-performance computing environments, further enhancing overall efficiency and performance.

## ConnectX-8 Extension Options

There are two available extension options:

1. For **900-9X81Q-00CN-ST0** and **900-9X81E-00EX-ST0**: Utilizing the Socket-Direct/Multi-Host capability, where the PCIe extension card is connected to the

SuperNIC, and is used as an end-point.

2. For **900-9X81E-00EX-DTO**: Utilizing the Down Stream Port (DSP) option, where the MCIO connector is used as a root complex for storage devices (GPUs or SSDs).

## Socket Direct SuperNICs

The Socket Direct™ technology offers improved performance to dual-socket servers by enabling direct access from each CPU in a dual-socket server to the network through its dedicated PCIe interface. Utilizing the Socket-Direct or the Multi-Host capability, the PCIe extension card is connected to the SuperNIC and is used as an end-point extension.

NVIDIA offers ConnectX-8 Socket Direct, which enables 800Gb/s or 400Gb/s connectivity for servers with PCIe Gen5 or Gen4 capability, respectively. The SuperNIC's 32-lane PCIe bus is split into two 16-lane buses, with one bus accessible through a PCIe x16 edge connector and the other bus through an x16 Auxiliary PCIe Connection card. The two cards should be installed into two PCIe x16 slots and connected using an MCIO harness.

Please order the additional PCIe Auxiliary Card kit to use the SuperNIC in the Socket-Direct configuration. SuperNICs that support Socket Direct can function as separate x16 PCIe cards.

For more information, please refer to the [PCIe Auxiliary Card Kit](#).

## Down Stream Port (DSP)

The ConnectX-8 SuperNIC with downstream port extension option provides connectivity to the server backplane or PCIe switch through the MCIO connector.

The default PCI interface is x4 x 4 to manage four SSD devices.

## System Requirements

Item	Description
<b>PCI Express Slot</b>	<b>In PCIe x16 Configuration</b> PCIe Gen6 @ 64GT/s through x16 edge connector <b>In PCIe x16 Extension Option (Socket Direct or Switch DSP)</b> <ul style="list-style-type: none"><li>• PCIe Gen5 SERDES @32GT/s through edge connector</li></ul>

Item	Description
	<ul style="list-style-type: none"> <li>• PCIe Gen5 SERDES @32GT/s through PCIe Auxiliary Connection Card or SFF-TA-1016 MCIO</li> </ul>
<b>System Power Supply</b>	Refer to <a href="#">Specifications</a>
<b>Operating System</b>	<ul style="list-style-type: none"> <li>• In-box drivers for major operating systems: <ul style="list-style-type: none"> <li>◦ Linux: RHEL, Ubuntu</li> <li>◦ Windows</li> </ul> </li> <li>• DOCA Host</li> <li>• OpenFabrics Windows Distribution (WinOF-2)</li> </ul>
<b>Connectivity</b>	<ul style="list-style-type: none"> <li>• Interoperable with 25/100/200/400 Gb/s Ethernet switches and SDR/EDR/HDR100/HDR/NDR/XDR InfiniBand switches</li> <li>• Passive copper cable with ESD protection</li> <li>• Powered connectors for optical and active cable support</li> </ul>

## Package Contents

Category	Qty	Item
Cards	1	ConnectX-8 SuperNIC
Accessories	1	Short bracket
	1	Tall bracket (shipped assembled on the SuperNIC)

**Optional Accessories, not included in the package, can be purchased separately:**

OPN	Description
<b>930-9XAX6-0025-000</b>	NVIDIA SocketDirect/MultiHost Auxiliary Kit for Additional PCIe Gen6x16 Connection, 250mm MCIO Harness
<b>930-9XCBL-000A-000</b>	NVIDIA ConnectX-8 200mm Cable Extender for Low-Speed Signals Over 30p Debug Connector

## Features and Benefits

### Note

Make sure to use a PCIe slot capable of supplying the required power and airflow to the ConnectX-8 SuperNICs as stated in the [Specifications](#) chapter.

### Note

This section describes hardware features and capabilities. Please refer to the relevant driver and firmware release notes for feature availability.

<b>PCI Express (PCIe)</b>	<p>According to the OPN you have purchased, the card uses the following PCIe express interfaces:</p> <ul style="list-style-type: none"><li>• <b>PCIe x16 configurations:</b> PCIe Gen6 (64GT/s) through x16 edge connector</li><li>• <b>2x PCIe x16 configurations (Socket-Direct/Mult-Host):</b> PCIe Gen6/5 ( SERDES @ 64GT/s / 32GT/s) through x16 edge connector PCIe Gen5 SERDES @ 32GT/s through PCIe Auxiliary Connection Card</li><li>• <b>2x PCIe x16 configurations (PCIe Down Stream Port Extension Option):</b> PCIe Gen5 ( SERDES @ 32GT/s ) through MCIO edge connector</li></ul>
<b>InfiniBand Architecture Specification v1.7 compliant</b>	<p>ConnectX-8 delivers low latency, high bandwidth, and computing efficiency for high-performance computing (HPC), artificial intelligence (AI), and hyperscale cloud data center applications. ConnectX-8 is InfiniBand Architecture Specification v1.7 compliant.</p> <b>InfiniBand Network Protocols and Rates</b>

**For 900-9X81E-00EX-ST0 and 900-9X81E-00EX-DT0:**

Protocol	Standard	Port Width Rate (Gb/s)			Encoding
		4x (4 lane) Port	2x (2 lane) Port	1x (1 lane) Port	
XDR	IBTA Vol1 1.7	--	425	212.5	PAM4
NDR	IBTA Vol2 1.5	425	212.5	--	PAM4
HDR	IBTA Vol2 1.4	212.5	106.25	53.125	PAM4

**For 900-9X81Q-00CN-ST0:**

Protocol	Standard	Port Width Rate (Gb/s)			Encoding
		4x (4 lane) Port	2x (2 lane) Port	1x (1 lane) Port	
NDR	IBTA Vol2 1.5	425	212.5	--	PAM4
HDR	IBTA Vol2 1.4	212.5	106.25	53.125	PAM4

**Up to 400 Gigabit Ethernet**

ConnectX-8 SuperNICs comply with the following IEEE 802.3 standards:  
400GbE / 200GbE / 100GbE / 25GbE / 10GbE

Protocol	Ethernet Network Rate
IEEE802.3ck	100/200/400Gb/s Gigabit Ethernet (Include ETC enhancement)
IEEE802.3cd IEEE802.3bs IEEE802.3cm IEEE802.3cn IEEE802.3cu	50/100/200/400Gb/s Gigabit Ethernet (Include ETC enhancement)
IEEE 802.3bj IEEE 802.3bm	100 Gigabit Ethernet
IEEE 802.3by	25/50 Gigabit Ethernet

	<b>Protocol</b>	<b>Ethernet Network Rate</b>
	Ethernet Technology Consortium	
	IEEE 802.3ba	40 Gigabit Ethernet
	IEEE 802.3ae	10 Gigabit Ethernet
	IEEE 802.3cb	2.5/5 Gigabit Ethernet (For 2.5: support only 2.5 x1000BASE-X)
	IEEE 802.3ap	Based on auto-negotiation and KR startup
	IEEE 802.3ad IEEE 802.1AX	Link Aggregation
	IEEE 802.1Q IEEE 802.1P VLAN tags and priority	
	IEEE 802.1Qau (QCN) Congestion Notification IEEE 802.1Qaz (ETS) IEEE 802.1Qbb (PFC) IEEE 802.1Qbg IEEE 1588v2 IEEE 802.1AE (MACSec) Jumbo frame support (9.6KB)	
<b>Memory Components</b>	<ul style="list-style-type: none"> <li>• SPI - includes 512Mbit SPI Quad Flash device.</li> <li>• FRU EEPROM - Stores the parameters and personality of the SuperNIC. The EEPROM capacity is 128Kbit. FRU I2C address is (0x50) and is accessible through the PCIe SMBus. (Note: Address 0x58 is reserved.)</li> </ul>	
<b>Overlay Networks</b>	<p>In order to better scale their networks, data center operators often create overlay networks that carry traffic from individual virtual machines over logical tunnels in encapsulated formats such as NVGRE and VXLAN. While this solves network scalability issues, it hides the TCP packet from the hardware offloading engines, placing higher loads on the host CPU. ConnectX-8 effectively addresses this by providing advanced NVGRE and VXLAN hardware offloading engines that encapsulate and de-encapsulate the overlay protocol.</p>	
<b>Quality of</b>	Support for port-based Quality of Service enabling various application	

<b>Service (QoS)</b>	requirements for latency and SLA.
<b>Hardware-based I/O Virtualization</b>	ConnectX-8 provides dedicated adapter resources and guaranteed isolation and protection for virtual machines within the server.
<b>SR-IOV</b>	ConnectX-8 SR-IOV technology provides dedicated adapter resources and guaranteed isolation and protection for virtual machines (VM) within the server.
<b>High-Performance Accelerations</b>	<ul style="list-style-type: none"> <li>• Vector collective operations offload</li> <li>• MPI_Alltoall offloads</li> <li>• Rendezvous protocol offload</li> </ul>
Secure Boot	The secure boot process assures the booting of authentic firmware/software that is intended to run on ConnectX-8. This is achieved using cryptographic primitives using asymmetric cryptography. ConnectX-8 supports several cryptographic functions in its HW Root-of-Trust (RoT) that has its key stored in on-chip FUSES.
Secure Firmware Update	The Secure firmware update feature enables a device to verify digital signatures of new firmware binaries to ensure that only officially approved versions can be installed from the host, the network, or a Board Management Controller (BMC). The firmware of devices with “secure firmware update” functionality (secure FW), restricts access to specific commands and registers that can be used to modify the firmware binary image on the flash, as well as commands that can jeopardize security in general. For further information, refer to the <a href="#">MFT User Manual</a> .
<b>Host Management</b>	<p>ConnectX-8 technology maintains support for host manageability through a BMC. ConnectX-8 PCIe stand-up adapter can be connected to a BMC using MCTP over SMBus or MCTP over PCIe protocols as if it is a standard NVIDIA PCIe stand-up SuperNIC. For configuring the adapter for the specific manageability solution in use by the server, please contact NVIDIA Support.</p> <ul style="list-style-type: none"> <li>• Protocols: PLDM, NCSI</li> <li>• Transport layer – RBT, MCTP over SMBus, and MCTP over PCIe</li> <li>• Physical layer: SMBus 2.0 / I2C interface for device control and configuration, PCIe</li> <li>• PLDM for Monitor and Control DSP0248</li> <li>• PLDM for Firmware Update DSP026</li> <li>• IEEE 1149.6</li> <li>• Secured FW update</li> <li>• FW Recovery</li> <li>• NIC reset</li> </ul>

	<ul style="list-style-type: none"> <li>• Monitoring and control</li> <li>• Network port settings</li> <li>• Boot setting</li> </ul>
<b>RDMA and RDMA over Converged Ethernet (RoCE)</b>	<p>ConnectX-8, utilizing IBTA RDMA (Remote Data Memory Access) and RoCE (RDMA over Converged Ethernet) technology, delivers low latency and high-performance over InfiniBand and Ethernet networks. Leveraging datacenter bridging (DCB) capabilities as well as ConnectX-8 advanced congestion control hardware mechanisms, RoCE provides efficient low-latency RDMA services over Layer 2 and Layer 3 networks.</p>
<b>NVIDIA PeerDirect™</b>	<p>PeerDirect™ communication provides high-efficiency RDMA access by eliminating unnecessary internal data copies between components on the PCIe bus (for example, from GPU to CPU), and therefore significantly reduces application run time. ConnectX-8 advanced acceleration technology enables higher cluster efficiency and scalability to tens of thousands of nodes.</p>
<b>CPU Offload</b>	<p>Adapter functionality enables reduced CPU overhead allowing more available CPU for computation tasks.</p> <ul style="list-style-type: none"> <li>• Flexible match-action flow tables</li> <li>• Open VSwitch (OVS) offload using ASAP<sup>2</sup>®</li> <li>• Tunneling encapsulation/decapsulation</li> </ul>
<b>Cryptography Accelerations</b>	<p>ConnectX-8 supports IPSec, MACSec, and PSP cryptography acceleration. Connectx-8 SuperNIC hardware-based accelerations offload the crypto operations and free up the CPU, reducing latency and enabling scalable crypto solutions.</p>

# Supported Interfaces

This section describes the ConnectX-8 SuperNIC supported interfaces. Each numbered interface referenced in the figures is described in the following table with a link to detailed information.

## **i** Note

The below figures are for illustration purposes only and might not reflect the current revision of the SuperNIC.

## ConnectX-8 Layout and Interface Information

ConnectX-8 Model	Front View	Back View
<b>C8240 SuperNICs</b> <ul style="list-style-type: none"> <li>900-9X81Q-00CN-ST0</li> </ul>	<p>The front view of the C8240 SuperNIC shows a brown PCB. Interface 1 is at the bottom center. Interface 2 is at the bottom left. Interface 3 is at the top left. Interface 4 is at the top right.</p>	<p>The back view of the C8240 SuperNIC shows a dark grey PCB. Interface 5 is located on the left side.</p>
<b>C8180 SuperNICs</b> <ul style="list-style-type: none"> <li>900-9X81E-00EX-ST0</li> <li>900-9X81E-00EX-DT0</li> </ul>	<p>The front view of the C8180 SuperNIC shows a brown PCB. Interface 1 is at the bottom center. Interface 2 is at the bottom left. Interface 3 is at the top left. Interface 4 is at the top right.</p>	<p>The back view of the C8180 SuperNIC shows a dark grey PCB. Interface 5 is located on the left side.</p>

ConnectX-8 Model	Front View	Back View
<b>C8180L Partner Cooled</b> <ul style="list-style-type: none"> <li>900-9X81E-00EX-SLO</li> </ul>		

Item	Interface	Description
	<a href="#">ConnectX-8 IC</a>	ConnectX-8 Integrated Circuit
1	<a href="#">Host Interface</a>	PCIe Gen6 through x16 edge connector
2	<a href="#">Networking Interfaces</a>	Network traffic is transmitted through the networking connectors. The networking connectors allow for the use of modules, optical and passive cable interconnect solutions
3	<a href="#">Networking Ports LEDs</a>	Two I/O LEDs per port to indicate speed and link status
4	<a href="#">MCIO Connector</a>	One MCIO connector is populated to allow connectivity to an additional PCIe x16 interface
5	<a href="#">Sideband Management Interface</a>	Allows for BMC connectivity for remote management

## Interfaces Detailed Description

### ConnectX-8 IC

The ConnectX-8 family of IC devices delivers InfiniBand and Ethernet connectivity paired with best-in-class hardware capabilities that accelerate and secure cloud and data-center workloads.

### Host Interface

ConnectX-8 SuperNIC supports PCI Express Gen6 (5.0 and 4.0 compatible) through an x16 edge connector. The following lists host interface features:

- PCIe Gen6 or Gen5
- NVIDIA Multi-Host™ (up to 4 hosts)
- PCIe switch downstream port containment (DPC) - Applies to 900-9X81E-00EX-DT0 only
- MSI/MSI-X

# Networking Interfaces

**Note**

The SuperNIC includes special circuits to protect the SuperNIC/server from ESD shocks when plugging copper cables.

Ethernet and InfiniBand traffic is transmitted through the networking connectors (QSFP112 or OSFP) on the SuperNIC.

Protocol	Specifications
Ethernet	The network ports comply with the IEEE 802.3 Ethernet standards in <a href="#">Features and Benefits</a> .
InfiniBand	The network ports are compliant with the <a href="#">InfiniBand Architecture Specification, Release 1.7</a> .

## Networking Ports LEDs Specifications

For the description of the networking ports LEDs, follow the table below, depending on the ConnectX-8 SuperNIC you have purchased.

SKU	LEDs Scheme
C8240 SuperNICs <ul style="list-style-type: none"><li>900-9X81Q-00CN-ST0</li></ul>	<a href="#">Scheme 1: One Bi-Color LED</a>

SKU	LEDs Scheme
C8180 SuperNICs <ul style="list-style-type: none"> <li>• 900-9X81E-00EX-ST0</li> <li>• 900-9X81E-00EX-DT0</li> <li>• 900-9X81E-00EX-SL0</li> </ul>	Scheme 2: Two LEDs

## Scheme 1: One Bi-Color LED

There is one bi-color (Yellow and Green) I/O LED per port that indicate port speed and link status.

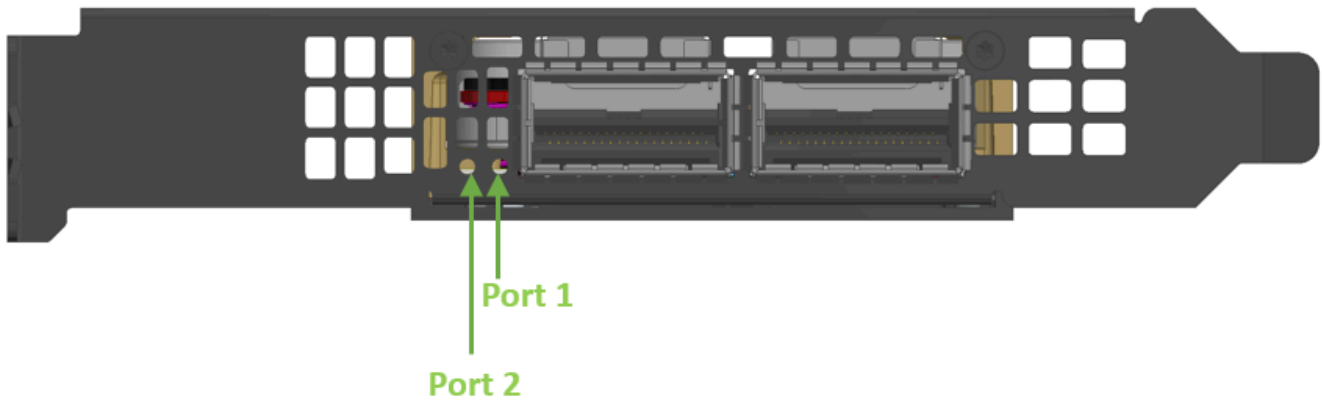

State	Bi-Color LED (Yellow/Green)									
Beacon command for locating the SuperNIC	1 Hz blinking Yellow									
Error	4Hz blinking Yellow Indicates an error with the link. The error can be one of the following:									
	<table border="1"> <thead> <tr> <th>Error Type</th> <th>Description</th> <th>LED Behavior</th> </tr> </thead> <tbody> <tr> <td>I<sup>2</sup>C</td> <td>I<sup>2</sup>C access to the networking ports fails</td> <td>Blinks until the error is fixed</td> </tr> <tr> <td>Over-current</td> <td>Over-current condition of the networking ports</td> <td>Blinks until the error is fixed</td> </tr> </tbody> </table>	Error Type	Description	LED Behavior	I <sup>2</sup> C	I <sup>2</sup> C access to the networking ports fails	Blinks until the error is fixed	Over-current	Over-current condition of the networking ports	Blinks until the error is fixed
	Error Type	Description	LED Behavior							
I <sup>2</sup> C	I <sup>2</sup> C access to the networking ports fails	Blinks until the error is fixed								
Over-current	Over-current condition of the networking ports	Blinks until the error is fixed								
Physical Activity	The Green LED will blink.									
Link Up	The Green LED will be solid.									

<b>State</b>	<b>Bi-Color LED (Yellow/Green)</b>
Physical Up (IB Only)	The Yellow LED will be solid.

## Scheme 2: Two LEDs

There are two I/O LEDs per port that indicate port speed and link status.

- LED1 is a bi-color LED (Yellow and Green)
- LED2 is a single-color LED (Green)

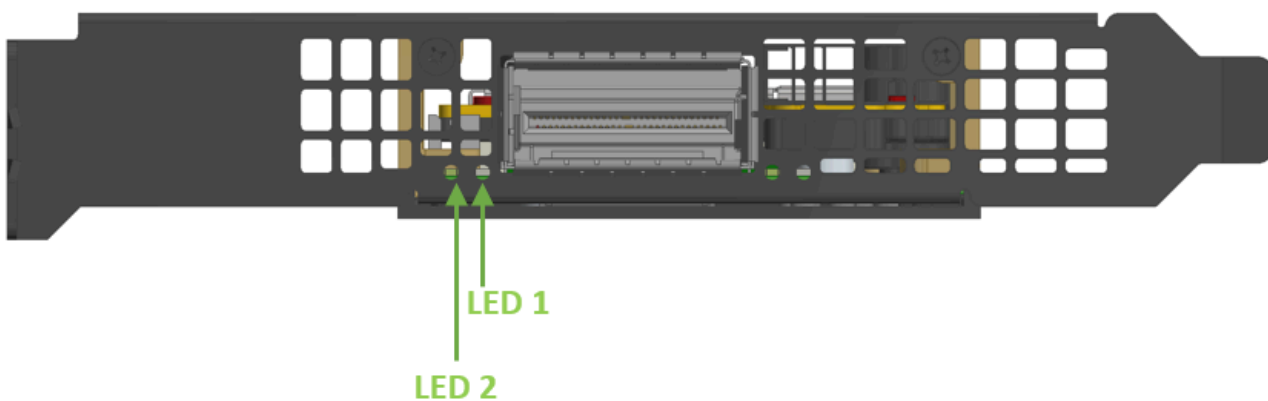

State	Bi-Color LED (Yellow/Green)	Single Color LED (Green)	
Beacon command for locating the SuperNIC	1 Hz blinking Yellow	OFF	
Error	4Hz blinking Yellow Indicates an error with the link. The error can be one of the following:		
	<b>Error Type</b>	<b>Description</b>	<b>LED Behavior</b>
	I <sup>2</sup> C	I <sup>2</sup> C access to the networking ports fails	Blinks until the error is fixed
	Over-current	Over-current condition of the networking ports	Blinks until the error is fixed
Physical Activity	In full port speed: the Green LED is solid	Blinking	

State	Bi-Color LED (Yellow/Green)	Single Color LED (Green)
	In less than full port speed: the Yellow LED is solid	
Link Up	In full port speed: the Green LED is solid In less than full port speed: the Yellow LED is solid	ON
Physical Up (IB Only)	The Yellow LED will be solid.	

## MCIO Connector

The MCIO (Multi-Channel I/O) connector in ConnectX-8 SuperNICs is a high-speed interface that provides efficient, scalable, and flexible connectivity for various data center applications. This connector supports multiple lanes of high-bandwidth data transfer, enabling faster and more efficient communication between the network card and the system or other connected components.

The 124 pins MCIO connector (SFF-TA-1016 by Amphenol) allows connectivity to an additional PCIe x16 interface or DSP devices (NVMe SSDs) via the MCIO cable. For pinouts, refer to the [MCIO Interface](#).

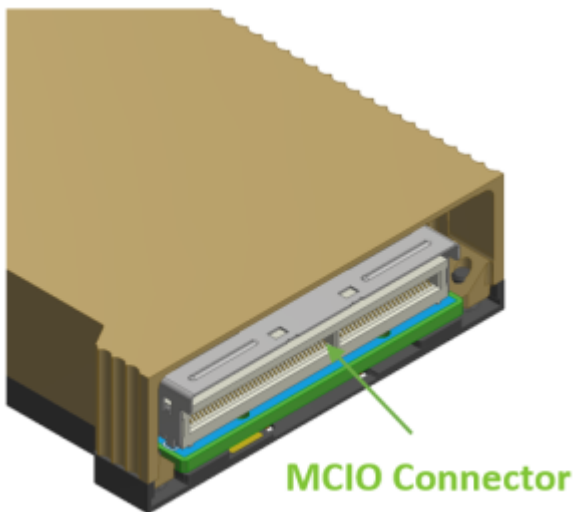

## Sideband Management Interface

The sideband management interface in ConnectX-8 SuperNICs enhances remote manageability, diagnostics, and maintenance capabilities, critical for high-availability

environments like data centers and cloud infrastructure.

The sideband management interface (a 30-pin IPEX connector) in ConnectX-8 SuperNICs enables out-of-band management, allowing administrators to monitor and control the network device independently of regular data traffic. It supports remote monitoring, even when the host system is unresponsive, by integrating with Baseboard Management Controllers (BMC) for tasks like firmware updates, diagnostics, and health monitoring. This interface ensures continuous management of the NIC's performance, security, and status without disrupting network operations, making it vital for maintaining uptime in data centers and cloud environments.

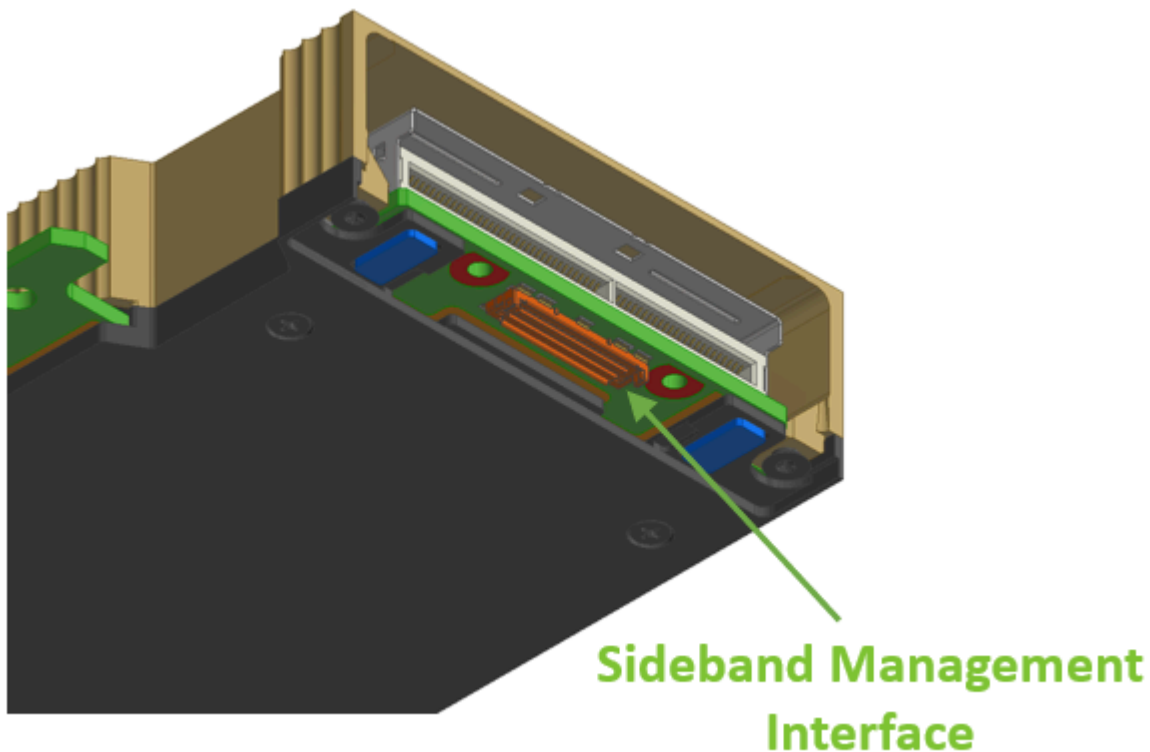

The table below specifies the maximum trace lengths per board type. Please consider the maximum trace length on the board in your design.

SKUs	Maximum Trace Length on the Board
<b>C8240 SuperNIC</b> 900-9X81Q-00CN-ST0	140mm (5.51 inch)
<b>C8180 SuperNICs</b> 900-9X81E-00EX-ST0 900-9X81E-00EX-DT0 900-9X81E-00EX-SL0	75mm (2.95 inch)

## ConnectX-8 Cable Extender Debugging Kit

An optional accessory is available for debugging purposes. The ConnectX-8 Cable Extender board provides access to the MTUSB, PPS, NCSI, EN\_INB\_REC, and FNP interfaces, enabling debugging.

The kit includes the extender board and a 200mm IPEX cable ( micro-coax, pin-to-pin, lock-to-lock ) that can be connected via the 30-pin connector on the ConnectX-8 SuperNIC.

OPN	Description
<b>930-9XCBL-000A-000</b>	NVIDIA ConnectX-8 200mm Cable Extender for Low-Speed Signals Over 30p Debug Connector

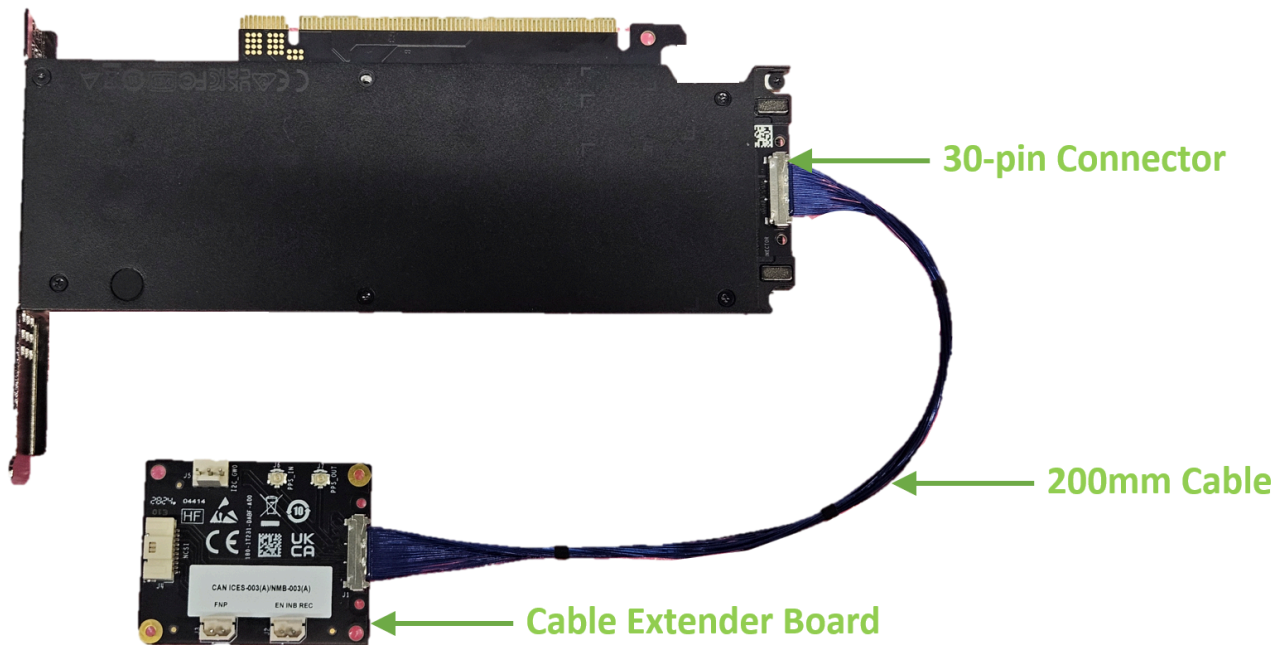

## Pinouts Description

### NC-SI Sideband Interface

The following table lists the NC-SI management interface pinout descriptions. For further details, please refer to [NC-SI Sideband Interface](#).

Pin Name	Pin Description
GND	Ground
RBT_RDX0	Receive data.
RBT_RDX1	Data signals from the network controller to the BMC.
RBT_CRSDV	Carrier sense/receive data validly
GND	Ground
RBT_TX0	Transmit data.
RBT_TX1	Data signals from the BMC to the network controller
RBT_TX_EN	Transmit enable
RBT_REF_CLK	RBT Reference clock
GND	Ground
ARB_OUT	NC-SI hardware arbitration output
ARB_IN	NC-SI hardware arbitration input
GND	Ground
I2C_CLK0	I2C clock (Debug)
I2C_SDA0	I2C Data (Debug)
PKG_ID0	NC-SI PKG_ID [0]
PKG_ID1	NC-SI PKG_ID [1]
RBT_ISOLATE_N	The signal used to indicate the board has powered and is ready for the NC-SI physical layer connection to be present
FNP	ConnectX Flash is NOT present
enable_inband_recovery	PCIe operatiin live fish mode
PPS IN	PPS input for timing applications
PPS OUT	PPS output for timing applications
RSVD3	Reserved
RSVD4	Reserved
RSVD5	Reserved
RSVD6	Reserved
RSVD7	Reserved

Pin Name	Pin Description
RSVD8	Reserved
RSVD9	Reserved
RSVD10	Reserved

## MCIO Interface

The tables below list the MCIO connector pinout descriptions, per SuperNIC OPN. For further details, please refer to [MCIO Connector](#).

### Default (Socket-Direct) Pinouts for 900-9X81Q-00CN-ST0 and 900-9X81E-00EX-ST0 SuperNICs

Additional Electrical Information	Description/Direction	Pin	Pin	Description/Direction	Additional Electrical Information
	GND	A1	B1	GND	
	PERp0	A2	B2	PETp0	
	PERn0	A3	B3	PETn0	
	GND	A4	B4	GND	
	PERp1	A5	B5	PETp1	
	PERn1	A6	B6	PETn1	
	GND	A7	B7	GND	
<b>Logic:</b> Open-drain <b>Voltage Level:</b> 3.3V <b>Presence of PU/PD:</b> PU 100k ohm	SMBUS_SCL (IN)	A8	B8	3V3_AUX (IN)	<b>Logic</b> power require as 3V in PCI <b>Voltage Level:</b>
<b>Logic:</b> Open-drain <b>Voltage Level:</b> 3.3V <b>Presence of PU/PD:</b> PU	SMBUS_SDA (BID)	A9	B9	FLEXIO0_A	<b>Presence of PU/PD:</b> PU termi 42.2 c

<b>Additional Electrical Information</b>	<b>Description/Direction</b>	<b>Pin</b>	<b>Pin</b>	<b>Description/Direction</b>	<b>Addit Electri Infor</b>
100k ohm					
	GND	A10	B10	GND	
<b>Logic:</b> Push-pull, active low <b>Voltage Level:</b> 3.3V	PERST_A_N (IN)	A11	B11	REFCLK_A_Dp (IN)	<b>Logic</b> REFCI
<b>Logic:</b> Active low <b>Voltage Level:</b> 3.3V <b>Presence of PU/PD:</b> PD 200 ohm <b>Recommended implementation on System level:</b> PU 100k ohm	CBL_PRES_A (OUT)	A12	B12	REFCLK_A_Dn (IN)	<b>Logic</b> REFCI
	GND	A13	B13	GND	
	PERp2	A14	B14	PETp2	
	PERn2	A15	B15	PETn2	
	GND	A16	B16	GND	
	PERp3	A17	B17	PETp3	
	PERn3	A18	B18	PETn3	
	GND	A19	B19	GND	
	PERp4	A20	B20	PETp4	
	PERn4	A21	B21	PETn4	
	GND	A22	B22	GND	
	PERp5	A23	B23	PETp5	
	PERn5	A24	B24	PETn5	
	GND	A25	B25	GND	

<b>Additional Electrical Information</b>	<b>Description/Direction</b>	<b>Pin</b>	<b>Pin</b>	<b>Description/Direction</b>	<b>Addit Electri Inforr</b>
<b>Presence of PU/PD:</b> PD termination 42.2 ohm	FLEXIO3_A/I2C_M_SDA_A (NC)	A26	B26	FLEXIO1_A/REFCLK_B_Dp	<b>Prese PU/PI</b> termi 42.2 c
<b>Presence of PU/PD:</b> PD termination 42.2 ohm	FLEXIO4_A/I2C_M_SCL_A (NC)	A27	B27	FLEXIO2_A/REFCLK_B_Dn	<b>Prese PU/PI</b> termi 42.2 c
	GND	A28	B28	GND	
<b>Presence of PU/PD:</b> PD termination 42.2 ohm	PERST_B_N (IN)	A29	B29	FLEXIO7_A	<b>Prese PU/PI</b> termi 42.2 c
<b>Presence of PU/PD:</b> PD termination 42.2 ohm	CBL_PRES_B (OUT)	A30	B30	FLEXIO8_A	<b>Prese PU/PI</b> termi 42.2 c
	GND	A31	B31	GND	
	PERp6	A32	B32	PETp6	
	PERn6	A33	B33	PETn6	
	GND	A34	B34	GND	
	PERp7	A35	B35	PETp7	
	PERn7	A36	B36	PETn7	
	GND	A37	B37	GND	
	<b>Key</b>				
	GND	A38	B38	GND	
	PERp8	A39	B39	PETp8	
	PERn8	A40	B40	PETn8	
	GND	A41	B41	GND	
	PERp9	A42	B42	PETp9	
	PERn9	A43	B43	PETn9	

<b>Additional Electrical Information</b>	<b>Description/Direction</b>	<b>Pin</b>	<b>Pin</b>	<b>Description/Direction</b>	<b>Addit Electr Inforr</b>
	GND	A44	B44	GND	
	PERp10	A45	B45	PETp10	
	PERn10	A46	B46	PETn10	
	GND	A47	B47	GND	
	PERp11	A48	B48	PETp11	
	PERn11	A49	B49	PETn11	
	GND	A50	B50	GND	
	PERp12	A51	B51	PETp12	
	PERn12	A52	B52	PETn12	
	GND	A53	B53	GND	
	PERp13	A54	B54	PETp13	
	PERn13	A55	B55	PETn13	
	GND	A56	B56	GND	
	PERp14	A57	B57	PETp14	
	PERn14	A58	B58	PETn14	
	GND	A59	B59	GND	
	PERp15	A60	B60	PETp15	
	PERn15	A61	B61	PETn15	
	GND	A62	B62	GND	

## Switch Mode Pinouts for 900-9X81E-00EX-DT0 SuperNICs

<b>Additional Electrical Information</b>	<b>Direction</b>	<b>Description/Direction</b>	<b>Pin</b>	<b>Pin</b>	<b>Description,</b>
		GND	A1	B1	GND
		PERp0	A2	B2	PETp0

Additional Electrical Information	Direction	Description/Direction	Pin	Pin	Description
		PERn0	A3	B3	PETn0
		GND	A4	B4	GND
		PERp1	A5	B5	PETp1
		PERn1	A6	B6	PETn1
		GND	A7	B7	GND
<b>Logic:</b> Same power requirements as 3V3_AUX in PCIe spec <b>Voltage Level:</b> 3.3V	OUT	3V3_AUX (OUT)	A8	B8	SMBUS_SCL
<b>Logic:</b> Open-drain <b>Voltage Level:</b> 3.3V <b>Recommended implementation on System level:</b> PU resistor	IN	VPP_INT_N (IN)	A9	B9	SMBUS_SDA
		GND	A10	B10	GND
<b>Logic:</b> PCIe REFCLK OUT	OUT	REFCLK_A_Dp (OUT)	A11	B11	PERST_A_N
<b>Logic:</b> PCIe REFCLK OUT	OUT	REFCLK_A_Dn (OUT)	A12	B12	CBL_PRESENCE

<b>Additional Electrical Information</b>	<b>Direction</b>	<b>Description/Direction</b>	<b>Pin</b>	<b>Pin</b>	<b>Description</b>
		GND	A13	B13	GND
		PERp2	A14	B14	PETp2
		PERn2	A15	B15	PETn2
		GND	A16	B16	GND
		PERp3	A17	B17	PETp3
		PERn3	A18	B18	PETn3
		GND	A19	B19	GND
		PERp4	A20	B20	PETp4
		PERn4	A21	B21	PETn4
		GND	A22	B22	GND
		PERp5	A23	B23	PETp5
		PERn5	A24	B24	PETn5
		GND	A25	B25	GND
<b>Logic:</b> Open-drain <b>Voltage Level:</b> 3.3V <b>Presence of PU/PD:</b> PU 1.5k ohm	BID	VPP_SDA_A	A26	B26	FLEXIO3_A /PWRBRK/SI
<b>Logic:</b> Open-drain <b>Voltage Level:</b> 3.3V <b>Presence of PU/PD:</b> PU 1.5k ohm	OUT	VPP_SCL_A	A27	B27	FLEXIO4_A /WAKE/SER_
		GND	A28	B28	GND
<b>Presence of PU/PD:</b> PD termination 42.2 ohm		FLEXIO7_A/USB2_A_Dp /SER_DO(NC)	A29	B29	PERST_B_N

Additional Electrical Information	Direction	Description/Direction	Pin	Pin	Description
<b>Presence of PU/PD:</b> PD termination 42.2 ohm		FLEXIO8_A/USB2_A_Dn/SER_DI(NC)	A30	B30	CBL_PRES_E
		GND	A31	B31	GND
		PERp6	A32	B32	PETp6
		PERn6	A33	B33	PETn6
		GND	A34	B34	GND
		PERp7	A35	B35	PETp7
		PERn7	A36	B36	PETn7
		GND	A37	B37	GND
		Key			
		GND	A38	B38	GND
		PERp8	A39	B39	PETp8
		PERn8	A40	B40	PETn8
		GND	A41	B41	GND
		PERp9	A42	B42	PETp9
		PERn9	A43	B43	PETn9
		GND	A44	B44	GND
		PERp10	A45	B45	PETp10
		PERn10	A46	B46	PETn10
		GND	A47	B47	GND
		PERp11	A48	B48	PETp11
		PERn11	A49	B49	PETn11
		GND	A50	B50	GND
		PERp12	A51	B51	PETp12
		PERn12	A52	B52	PETn12
		GND	A53	B53	GND

<b>Additional Electrical Information</b>	<b>Direction</b>	<b>Description/Direction</b>	<b>Pin</b>	<b>Pin</b>	<b>Description</b>
		PERp13	A54	B54	PETp13
		PERn13	A55	B55	PETn13
		GND	A56	B56	GND
		PERp14	A57	B57	PETp14
		PERn14	A58	B58	PETn14
		GND	A59	B59	GND
		PERp15	A60	B60	PETp15
		PERn15	A61	B61	PETn15
		GND	A62	B62	GND

---

# Hardware Installation

Installation and initialization of ConnectX-8 SuperNIC require attention to the mechanical attributes, power specification, and precautions for electronic equipment.

## Safety Warnings

### Info

Safety warnings are provided here in the English language. For safety warnings in other languages, refer to the [SuperNIC Installation Safety Instructions](#).

Please observe all safety warnings to avoid injury and prevent damage to system components. Note that not all warnings are relevant to all models.

Note that not all warnings are relevant to all models.

	<p><b>General Installation Instructions</b> Read all installation instructions before connecting the equipment to the power source.</p>
	<p><b>Jewelry Removal Warning</b> Before you install or remove equipment that is connected to power lines, remove jewelry such as bracelets, necklaces, rings, watches, and so</p>



on. Metal objects heat up when connected to power and ground and can meltdown, causing serious burns and/or welding the metal object to the terminals.



**Over-temperature**

This equipment should not be operated in an area with an ambient temperature exceeding the maximum recommended: 55°C (131°F). An airflow of 200LFM at this maximum ambient temperature is required for HCA cards and NICs. To guarantee proper airflow, allow at least 8cm (3 inches) of clearance around the ventilation openings.



**During Lightning - Electrical Hazard**

During periods of lightning activity, do not work on the equipment or connect or disconnect cables.

**Copper Cable Connecting/Disconnecting**

Some copper cables are heavy and not flexible, as such, they should be carefully attached to or detached from the connectors.



Refer to the cable manufacturer for special warnings and instructions.



**Equipment Installation**

This equipment should be installed, replaced, or serviced only by trained and qualified personnel.



**Equipment Disposal**

The disposal of this equipment should be in accordance to all national laws and regulations.

**Local and National Electrical Codes**

This equipment should be installed in compliance with local and national electrical codes.



### **Hazardous Radiation Exposure**

- Caution – Use of controls or adjustment or performance of procedures other than those specified herein may result in hazardous radiation exposure. For products with optical ports.
- CLASS 1 LASER PRODUCT and reference to the most recent laser standards: IEC 60 825-1:1993 + A1:1997 + A2:2001 and EN 60825-1:1994+A1:1996+ A2:20

## **Installation Procedure Overview**

The installation procedure of ConnectX-8 SuperNICs involves the following steps:

<b>Step</b>	<b>Procedure</b>	<b>Direct Link</b>
1	Check the system's requirements.	<a href="#">System Requirements</a>
2	Follow the safety precautions	<a href="#">Safety Precautions</a>
3	Unpack the package	<a href="#">Unpack the package</a>
5	Follow the pre-installation checklist	<a href="#">Pre-Installation Checklist</a>
6	(Optional) Replace the full-height mounting bracket with the supplied short bracket	<a href="#">Bracket Replacement Instructions</a>
7	Install the ConnectX-8 PCIe x16 SuperNIC	<a href="#">ConnectX-8 PCIe x16 Installation</a>

Step	Procedure	Direct Link
	in the chassis	<a href="#">Instructions</a>
	(Optional) Install the ConnectX-8 Extension Option (2x PCIe x16) in the chassis	<a href="#">ConnectX-8 Extension Option (2x PCIe x16) Installation Instructions</a>
8	Connect cables or modules to the cards	<a href="#">Cables and Modules</a>
9	Identify the SuperNIC in the system	<a href="#">Identifying Your SuperNIC</a>

## System Requirements

To successfully integrate the ConnectX-8 SuperNIC into a chassis, ensure that the following system requirements are met:

### Warning

Unless otherwise specified, NVIDIA products are designed to work in an environmentally controlled data center with low levels of gaseous and dust (particulate) contamination.

The operating environment should meet severity level G1 as per ISA 71.04 for gaseous contamination and ISO 14644-1 class 8 for cleanliness level.

### Hardware Requirements

- **Available PCIe Slot:**
  - Ensure the system has an available **PCIe Gen6 x16** slot or two **x16** slots for optimal performance. The ConnectX-8 SuperNIC requires a full-length PCIe slot for installation.
  - Ensure the chassis is compatible with the form factor of the ConnectX-8 SuperNIC (typically a **half-height, full-length** card).
- **Power Supply:**
  - Ensure the system's power supply unit (PSU) can provide sufficient power for the ConnectX-8 SuperNIC, typically requiring **75W** from the PSU.
- **Connectivity:**
  - The ConnectX-8 SuperNIC supports Ethernet and InfiniBand network connections. Ensure the chassis is connected to the appropriate network infrastructure (switches, routers, etc.).
- **MCIO Harness** (for dual-board setups):

- If connecting the PCIe auxiliary extension option in the chassis the system supports the necessary MCIO harnesses for board interconnects.

ConnectX-8 SuperNICs are offered with two airflow patterns: from the heatsink to the network ports, and vice versa, as shown below. Please refer to the [Specifications](#) section for airflow numbers for each SuperNIC model. The ConnectX-8 SuperNICs are available in two airflow configurations: from the heatsink to the network ports, or from the network ports to the heatsink illustrated below.

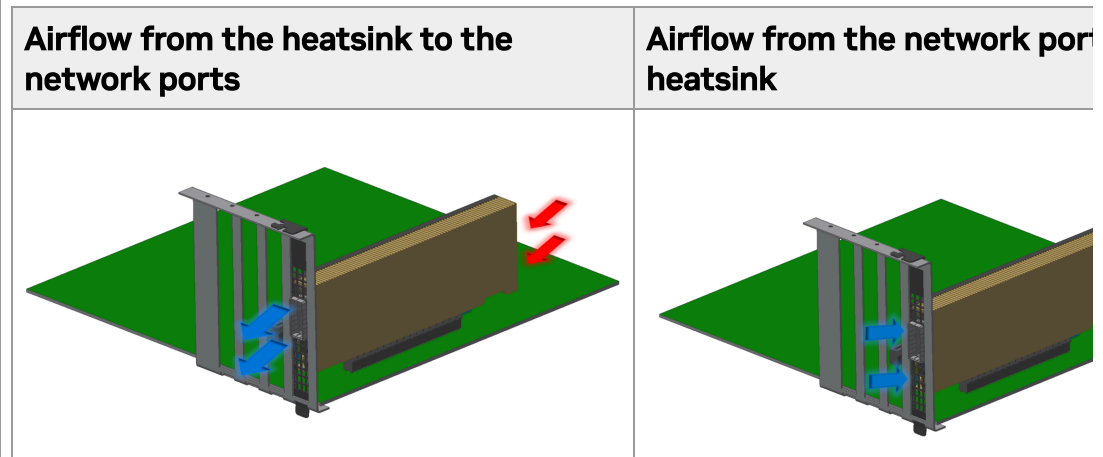

**Environmental Requirements**

- **Cooling and Ventilation:**
  - Adequate airflow is necessary to keep the ConnectX-8 SuperNIC. Ensure the chassis has sufficient cooling mechanisms, including or directed airflow near the PCIe slots. Refer to the [Specifications](#) section for the required airflow values.
  - The card may operate at high thermal loads during peak performance. Maintaining optimal ambient temperature is crucial to prevent overheating.
- **Chassis Size and Slot Availability:**
  - The chassis must have available PCIe slots of sufficient size (half height/full-length, depending on your configuration) and enough space for MCIO cable routing (if applicable).

**Software Requirements**

- **Operating System:**
  - Ensure the operating system supports the ConnectX-8 SuperNIC, including DOCA Host for Linux and Windows Server versions.
- **Firmware:**
  - Ensure that the firmware for the ConnectX-8 SuperNIC is up-to-date. Latest firmware versions may include critical bug fixes, performance improvements, and new features.

improvements, and support for new features.

- **Software:**
  - Ensure that the necessary network software and libraries are installed on the host, such as:
    - DOCA-Host for Linux
    - Windows Server drivers for Windows environments

## Safety Precautions Before Installing ConnectX-8 SuperNIC

### Pre-Installation Checklist

- Unpack the ConnectX-8 SuperNIC. Check against the package contents list that all the parts have been sent. Check the parts for visible damage that may have occurred during shipping. Please note that the cards must be placed on an antistatic surface. For package contents please refer to [Package Contents](#).

#### **Warning**

Please note that if the SuperNIC is removed hastily from the antistatic bag, the plastic ziplock may harm the EMI fingers on the networking connector. Carefully remove the SuperNIC from the antistatic bag to avoid damaging the EMI fingers.

- Shut down your system if active; Turn off the power to the system, and disconnect the power cord. Refer to the system documentation for instructions. Before you install the ConnectX-8 SuperNIC, make sure that the system is disconnected from power.
- (Optional) Check the mounting bracket on the ConnectX-8 or PCIe Auxiliary Connection Card; If required for your system, replace the full-height mounting bracket that is shipped mounted on the card with the supplied low-profile bracket. Refer to [Bracket Replacement Instructions](#).

### Bracket Replacement Instructions

The ConnectX-8 SuperNIC and PCIe Auxiliary Connection card are usually shipped with an assembled high-profile bracket. If this form factor is suitable for your requirements, you can skip the remainder of this section and move to [Installation Instructions](#). If you need to

replace the high-profile bracket with the short bracket that is included in the shipping box, please follow the instructions in this section.

### **Warning**

During the bracket replacement procedure, do not pull, bend, or damage the EMI fingers cage. It is recommended to limit bracket replacements to three times.

To replace the bracket you will need the following parts:

- The new brackets of the proper height
- The 2 screws saved from the removal of the bracket

### **Removing the Existing Bracket**

1. Using a torque driver, remove the two screws holding the bracket in place.
2. Separate the bracket from the ConnectX-8 SuperNIC.

### **Warning**

Be careful not to put stress on the LEDs on the SuperNIC.

3. Save the two screws.

### **Installing the New Bracket**

1. Place the bracket onto the SuperNIC until the screw holes line up.

### **Warning**

Do not force the bracket onto the SuperNIC.

2. Screw on the bracket using the screws saved from the bracket removal procedure above.

 **Warning**

Use a torque driver to apply up to 2 lbs-in torque on the screws.

## Installation Instructions

This section provides detailed instructions on how to install your SuperNIC in a system.

Choose the installation instructions according to the ConnectX-8 configuration you would like to use.

- [ConnectX-8 PCIe x16 Installation Instructions](#)
- [ConnectX-8 Extension Option \(2x PCIe x16\) Installation Instructions](#)

## Cables and Modules

### Networking Cable Installation and Uninstallation

Before connecting a cable to the SuperNIC, ensure that the bracket is fastened to the server chassis using a screw to prevent movement or unplugging of the SuperNIC when the cable is inserted or extracted.

1. All cables can be inserted or removed with the unit powered on.
2. To insert a cable, press the connector into the port receptacle until the connector is firmly seated.
  1. Support the weight of the cable before connecting the cable to the SuperNIC. Do this by using a cable holder or tying the cable to the rack.

2. Determine the correct orientation of the connector to the SuperNIC before inserting the connector. Do not try and insert the connector upside down. This may damage the SuperNIC.
3. Insert the connector into the SuperNIC. Be careful to insert the connector straight into the cage. Do not apply any torque, up or down, to the connector cage in the SuperNIC.
4. Make sure that the connector locks in place.

 **Note**

When installing cables make sure that the latches engage.

 **Warning**

Always install and remove cables by pushing or pulling the cable and connector in a straight line with the SuperNIC.

3. After inserting a cable into a port, the Green LED indicator will light when the physical connection is established (that is, when the unit is powered on and a cable is plugged into the port with the other end of the connector plugged into a functioning port). See [LED Interface](#) under the Interfaces section.
4. After plugging in a cable, lock the connector using the latching mechanism particular to the cable vendor. When data is being transferred the Green LED will blink. See [LED Interface](#) under the Interfaces section.
5. Care should be taken so as not to impede the air exhaust flow through the ventilation holes. Use cable lengths that allow for routing horizontally around to the side of the chassis before bending upward or downward in the rack.
6. To remove a cable, disengage the locks and slowly pull the connector away from the port receptacle. The LED indicator will turn off when the cable is unseated.

# Identifying the SuperNIC in Your System

## On Linux

Get the device location on the PCI bus by running `lspci` and locating lines with the string “Mellanox Technologies”:

ConnectX-8 Card Configuration	Output Example
Single-port Socket Direct Card/MultiHost (2x PCIe x16) OPN: 900-9X81Q-00CN-ST0	11:00.0 Infiniband controller: Mellanox Technologies CX8 Family [ConnectX-8] 59:00.0 Infiniband controller: Mellanox Technologies CX8 Family [ConnectX-8]
Dual-port Socket Direct Card/MultiHost (2x PCIe x16) OPN: 900-9X81Q-00CN-ST0	82:00.0 Ethernet controller: Mellanox Technologies CX8 Family [ConnectX-8] 82:00.1 Ethernet controller: Mellanox Technologies CX8 Family [ConnectX-8] 84:00.0 Ethernet controller: Mellanox Technologies CX8 Family [ConnectX-8] 84:00.1 Ethernet controller: Mellanox Technologies CX8 Family [ConnectX-8] <p>In the output example above, the first two rows indicate that one card is installed in a PCI slot with PCI Bus address 05 (hexadecimal), PCI Device number 00, and PCI Function numbers 0 and 1. The other card is installed in a PCI slot with PCI Bus address 82 (hexadecimal), PCI Device number 00, and PCI Function numbers 0 and 1.</p> <p>Since the two PCIe cards are installed in two PCIe slots, each card gets a unique PCI Bus and Device number. Each of the PCIe x16 busses sees two network ports; in effect, the two physical ports of the ConnectX-7 Socket Direct adapter are viewed as four net devices by the system.</p>
Single-port with x16 PCIe Down Stream Port Extension Option OPN: 900-9X81E-00EX-DT0	84:00.0 Ethernet controller: Mellanox Technologies CX8 Family [ConnectX-8]
Dual-port PCIe x16 Card OPN: 900-9X81Q-00CN-ST0	82:00.0 Ethernet controller: Mellanox Technologies CX8 Family [ConnectX-8]

ConnectX-8 Card Configuration	Output Example
	82:00.1 Ethernet controller: Mellanox Technologies CX8 Family [ConnectX-8]
Single-port PCIe x16 Card OPN: 900-9X81E-00EX-ST0	84:00.0 Ethernet controller: Mellanox Technologies CX8 Family [ConnectX-8]

## On Windows

1. Open Device Manager on the server. Click **Start => Run**, and then enter **devmgmt.msc**.
2. Expand **System Devices** and locate your ConnectX-8 SuperNIC.
3. Right-click the mouse on your SuperNIC's row and select **Properties** to display the SuperNIC properties window.
4. Click the **Details** tab and select **Hardware IDs** (Windows 2022/2019/2016/2012 R2) from the **Property** pull-down menu.

### PCI Device (Example)

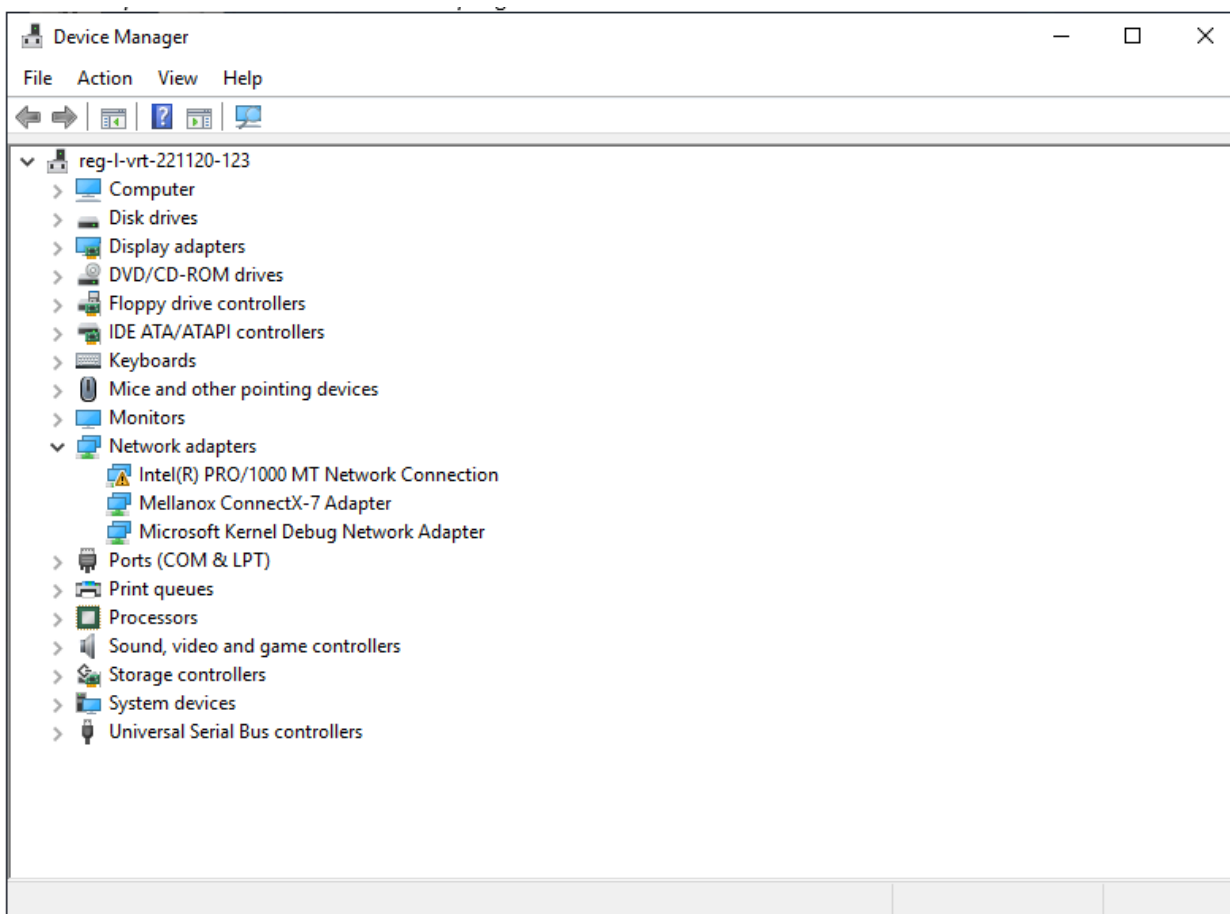

5. In the **Value** display box, check the fields VEN and DEV (fields are separated by '&'). In the display example above, notice the sub-string "PCI\VEN\_15B3&DEV\_1021": VEN is equal to 0x15B3 – this is the Vendor ID of Mellanox Technologies, and DEV is equal to 1023 (for ConnectX-8) – this is a valid NVIDIA PCI Device ID.

**Note**

If the PCI device does not have a SuperNIC ID, return to Step 2 to check another device.

**Note**

The list of NVIDIA PCI Device IDs can be found at the [PCI ID repository](#).

# ConnectX-8 PCIe x16 Installation Instructions

## Note

- This section applies to all SuperNICs. If you plan to utilize the Socket Direct/Multi-Host configuration (2x PCIe x16), please refer to the [ConnectX-8 Extension Option \(2x PCIe x16\) Installation Instructions](#).
- Ensure that the ConnectX-8 SuperNICs are installed in PCIe slots capable of supplying the required power and airflow, as specified in the product's specifications.
- The images provided below are for illustrative purposes only.

## Preparation

- **Power down the chassis:** Ensure the chassis is completely powered off. Disconnect it from any power source and remove all cables.
- **Discharge static electricity:** Put on an anti-static wrist strap or regularly touch a grounded metal surface to discharge any static electricity.
- Open the chassis:
  - Using the appropriate screwdriver, remove the screws securing the chassis side panel or top cover (depending on the chassis model). Set the screws aside in a safe place.
  - Locate an available PCIe slot that is compatible with the ConnectX-8 SuperNIC. Refer to the chassis and motherboard manual to ensure the PCIe slot supports

the NIC's specifications (PCIe Gen6 x16).

## Install the ConnectX-8 SuperNIC

- **Position the SuperNIC:** Carefully align the gold connector of the NIC with the PCIe slot. Ensure the card is lined up with the slot and the retention bracket aligns with the chassis screw holes.

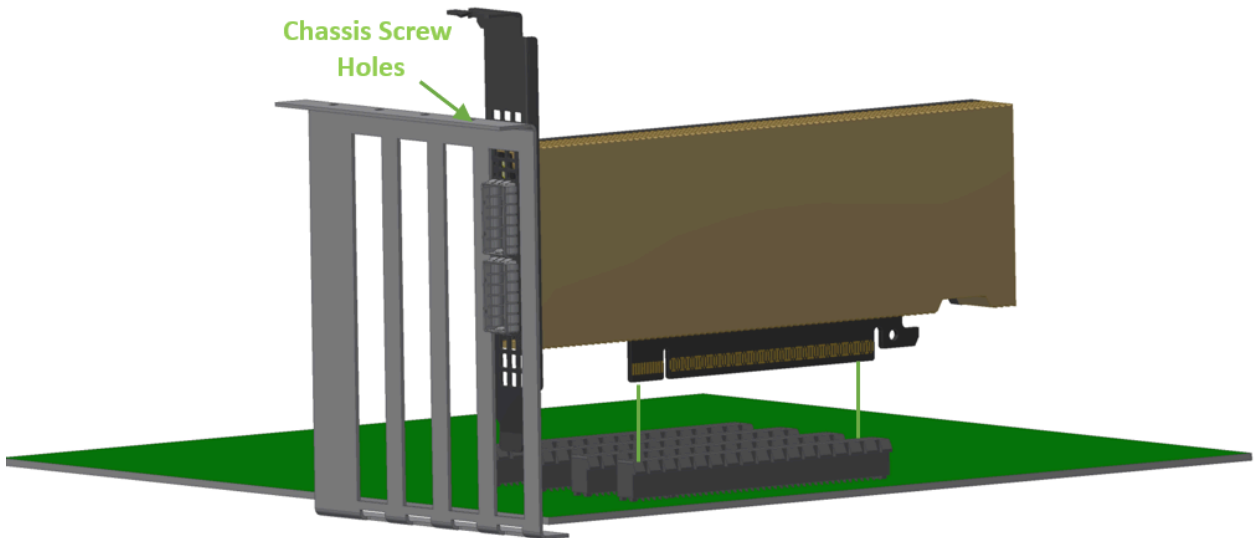

- **Insert the SuperNIC:** Gently but firmly push the NIC straight down into the PCIe slot until it is fully seated. Avoid excessive force.

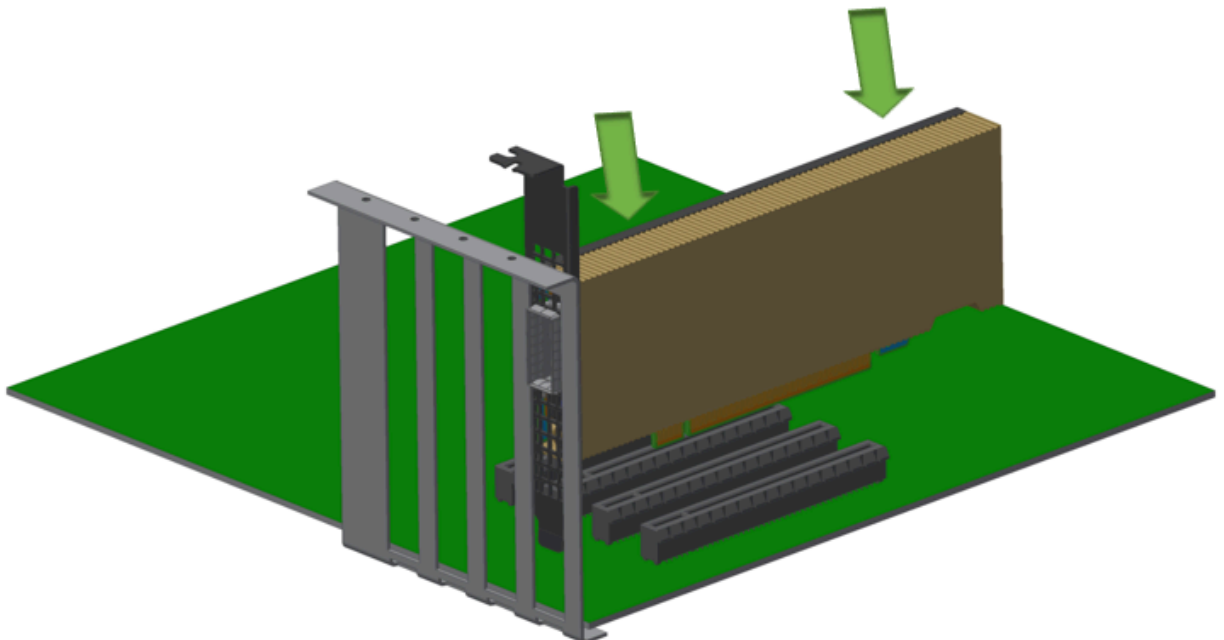

- **Secure the SuperNIC:** Use a screw (often provided with the chassis or card) to secure the card's metal bracket to the chassis. This prevents the card from moving and ensures a stable connection.

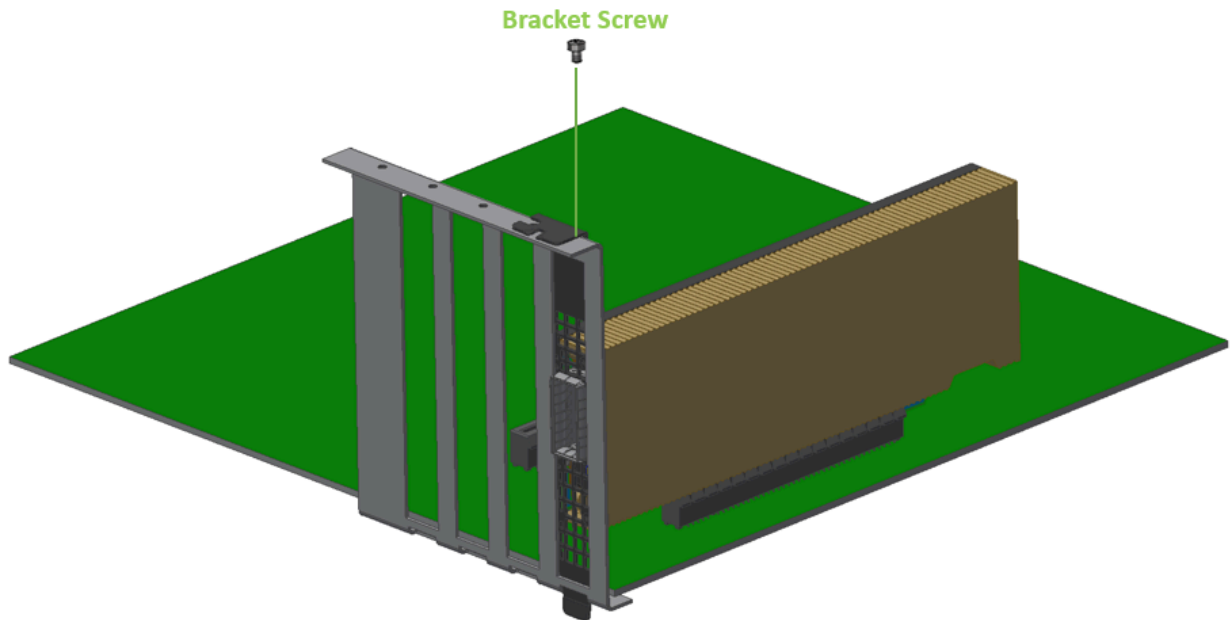

- Once the SuperNIC is securely installed, reattach the chassis side panel or top cover. Fasten the screws that were removed earlier.

## Connect Power and Cables

- Connect the power cable to the chassis.
- Install the network cables to the newly installed SuperNIC. For more information, refer to [Networking Cable Installation](#).
- Ensure the connections are secure before powering on the chassis.

## Power On and Verify the Installation

- Power on the chassis.
- Verify that the ConnectX-8 SuperNIC is properly recognized by the system. Depending on the operating system:
  - On **Linux**, run `lspci | grep Mellanox` to ensure the NIC is detected.

- On **Windows**, check the Device Manager under "Network Adapters" for the presence of the new NIC.

## Uninstallation Instructions

### Preparation

- Power down the chassis:
  - Shut down the system properly, then disconnect the power supply and all cables from the chassis to ensure it's completely powered off.
  - Wait 30 seconds.
- Discharge static electricity:
  - Use an anti-static wrist strap or touch a grounded metal object regularly to discharge any static electricity that could damage the components.

### Open the Chassis

- Using a screwdriver, unscrew and remove the chassis side panel (or top cover, depending on the chassis design). Keep the screws in a safe place for reassembly later.
- Identify the ConnectX-8 SuperNIC you wish to remove. It will be seated in one of the PCIe slots.

### Disconnect the Networking Cable

To remove the networking cable, disengage the locks and slowly pull the connector away from the port receptacle. The LED indicator will turn off when the cable is unseated. Note which cables go where if they will need to be reconnected later.

### Uninstall the ConnectX-8 SuperNIC

- Locate the screw that secures the SuperNIC's metal bracket to the chassis. Use a screwdriver to remove this screw, setting it aside safely.

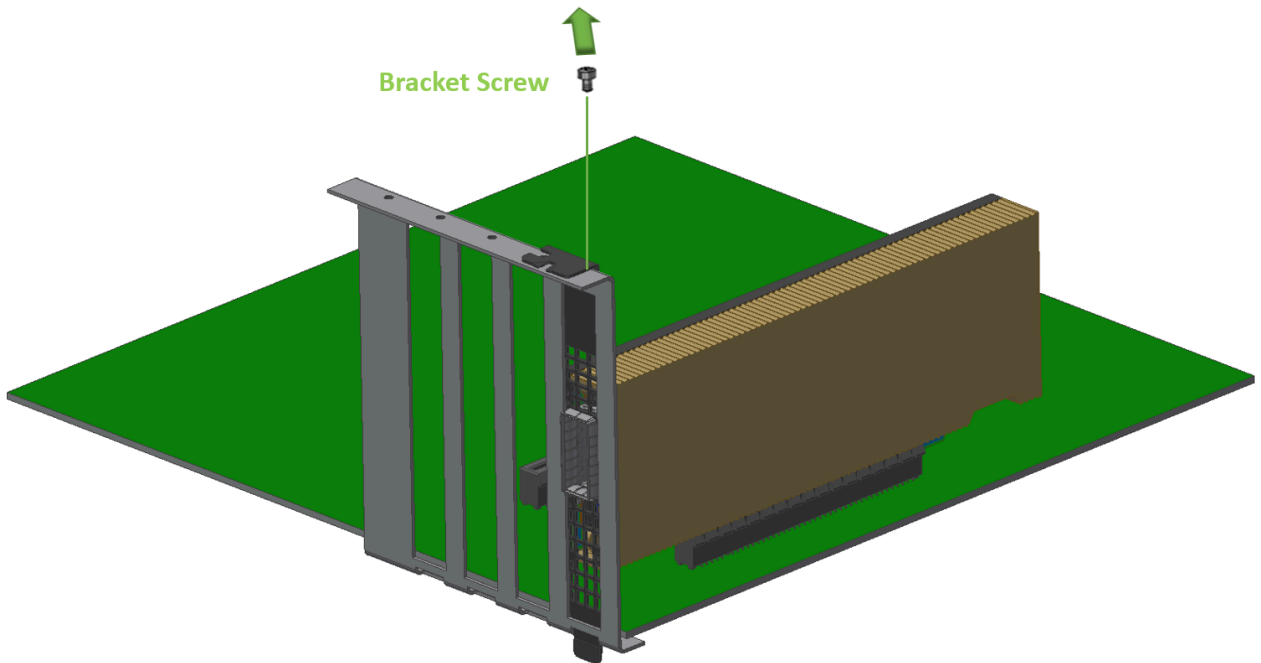

- Holding the edges of the SuperNIC, gently pull it upwards out of the PCIe slot. Apply even pressure to avoid damaging the slot or the card. Do not twist or force it out.

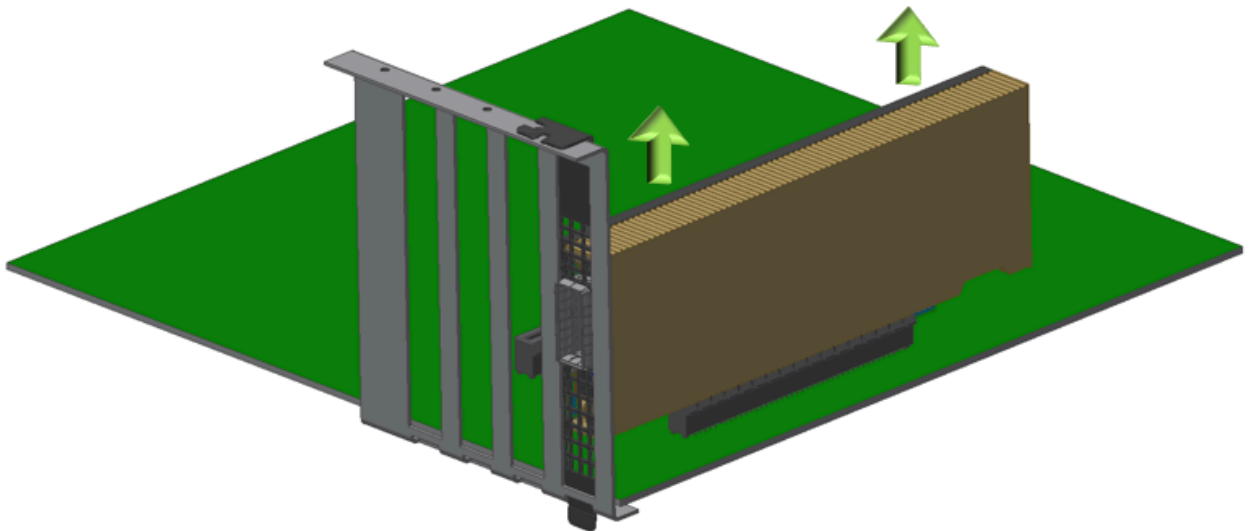

## **(Optional) Inspect and Clean the Components**

- If needed, inspect the PCIe slot and the NIC for dust or debris. Use compressed air to clean them, but avoid touching the connectors directly.

## Close the Chassis

- Once the SuperNIC is removed and any further maintenance is complete, replace the chassis side panel and secure it with the screws you removed earlier.

## Reconnect Power and Cables

- Reconnect the power cable and any necessary peripherals to the system.
- Ensure all connections are secure before powering the system back on.

## Power On and Verify

- Power on the system and verify that it operates correctly without the NIC.
- Depending on your operating system, you may need to check if the drivers for the NIC have been disabled or removed. On **Linux**, you can use `lspci` to verify the card is no longer detected, and on **Windows**, you can check the Device Manager under "Network Adapters."

# ConnectX-8 Extension Option (2x PCIe x16) Installation Instructions

### Note

- This section applies to SuperNICs when used with the extension option.

- The images below are for illustration purposes only.

## Installation Instructions

According to your server and your preferences, you may connect the SuperNIC to the supplied Auxiliary connection card using the harness before or after installing the SuperNIC into your chassis.

## Installing the SuperNIC in the Chassis

### Note

Please make sure to install the ConnectX-8 cards in a PCIe slot capable of supplying the required power and airflow as stated in the [Specifications](#).

Connect the ConnectX-8 SuperNIC in an available PCI Express x16 slot in the chassis. Refer to [ConnectX-8 PCIe x16 Installation Instructions](#).

## Connecting the MCIO Harness

- **Identify Connectors:** Locate the MCIO connectors on both the ConnectX-8 SuperNIC and the PCIe Auxiliary Board.
- **Connect the Harness:** Attach the MCIO harness to the connectors, ensuring a firm and secure connection. A click sound will be heard once the MCIO harness is properly installed on the cards.

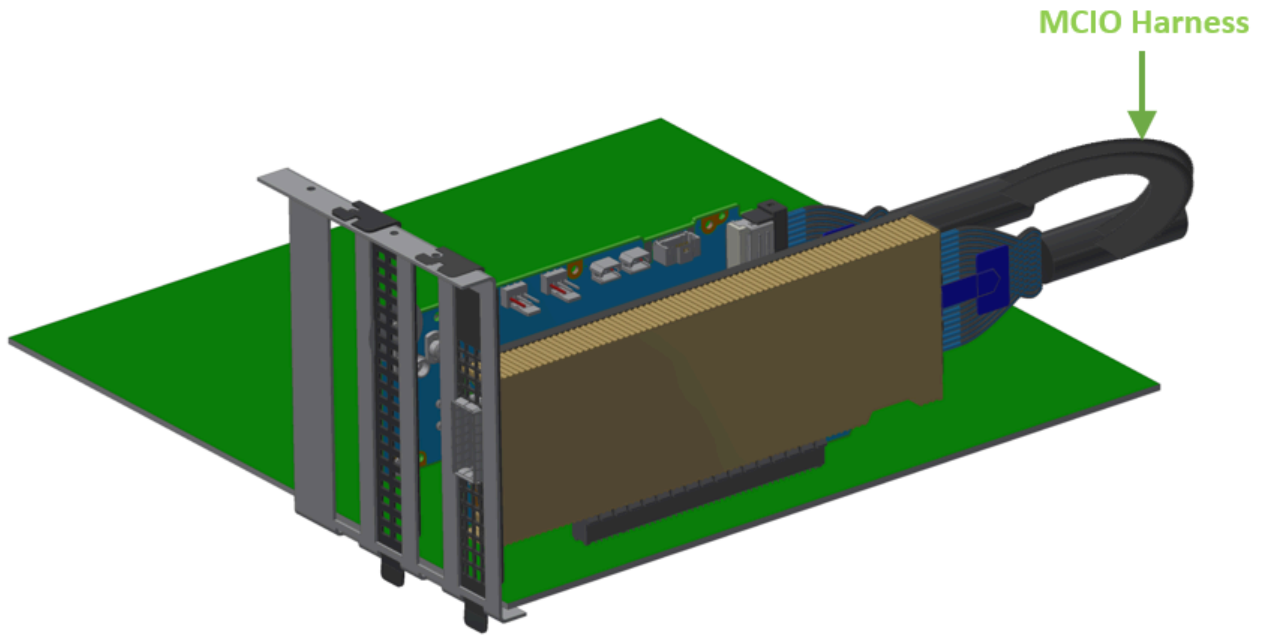

- **Route the Harness:** Carefully route the harness to avoid interference with other components and to maintain proper airflow.

## Installing the PCIe Auxiliary Card in the Chassis

Plan the installation of the PCIe Auxiliary card adjacent to the SuperNIC, ensuring that the MCIO harness length (250mm) is taken into account.

- **Position the PCIe Auxiliary Board:** Align the PCIe Auxiliary Board with an available PCIe slot.
- **Insert the Board:** Gently insert the board into the slot, applying even pressure until it is fully seated.

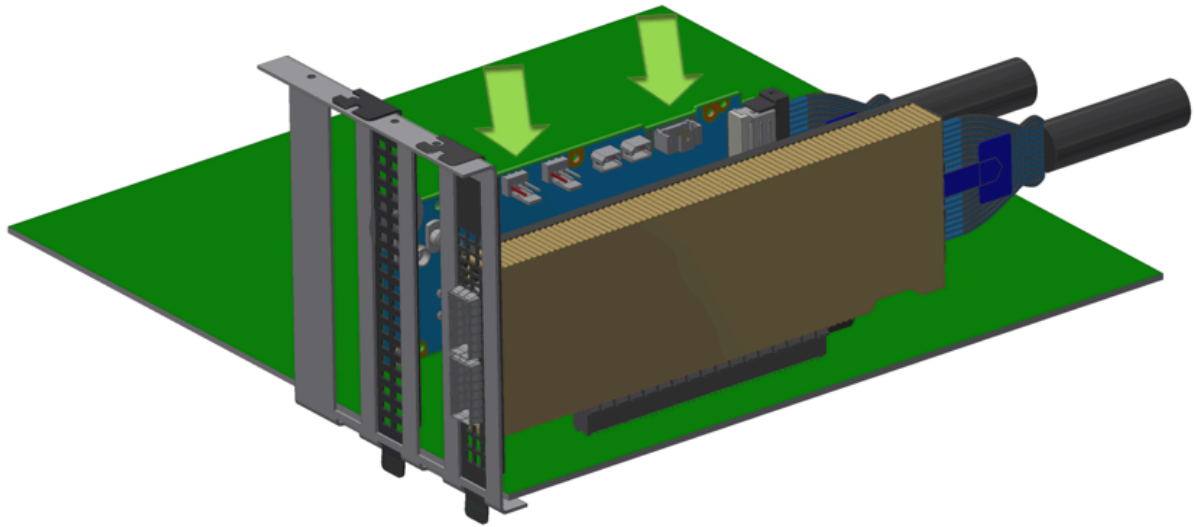

- **Secure the Board:** Use the chassis retention mechanisms (e.g., screws or latches) to secure the board in place.

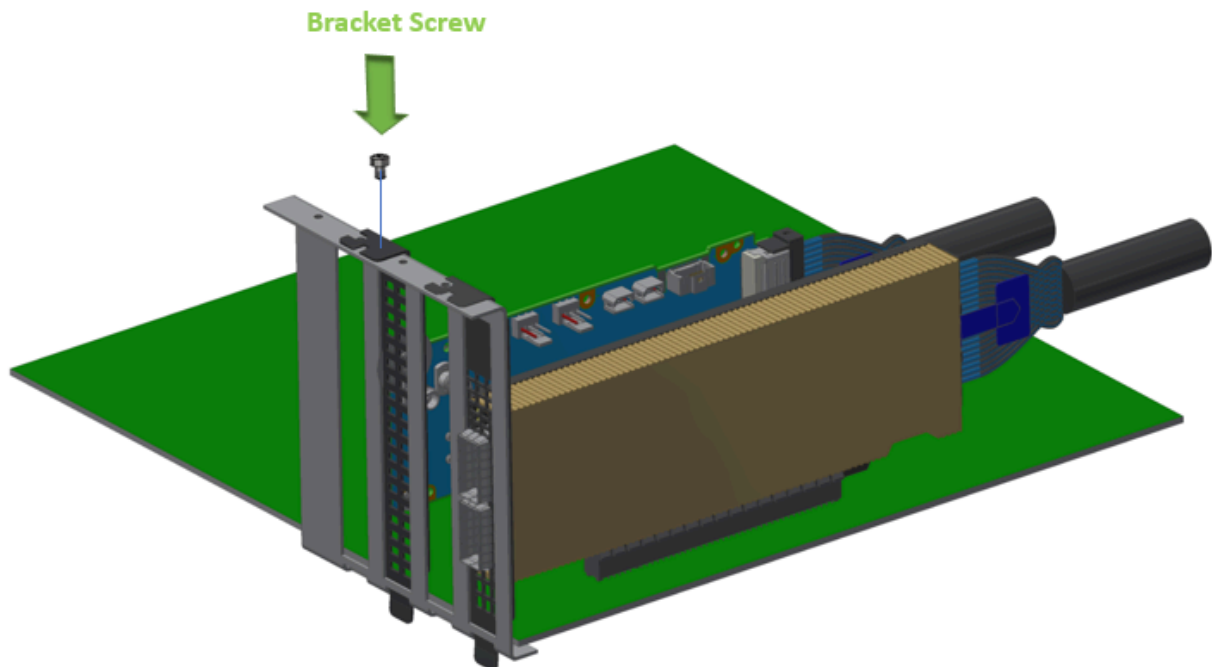

## Installing the Networking Cable

For more information, refer to [Networking Cable Installation](#).

# Uninstallation Instructions

## Preparation

- Power down the chassis:
  - Shut down the system properly, then disconnect the power supply and all cables from the chassis to ensure it's completely powered off.
  - Wait 30 seconds.
- Discharge static electricity:
  - Use an anti-static wrist strap or touch a grounded metal object regularly to discharge any static electricity that could damage the components.

## Open the Chassis

- Using a screwdriver, unscrew and remove the chassis side panel (or top cover, depending on the chassis design). Keep the screws in a safe place for reassembly later.
- Identify the ConnectX-8 SuperNIC you wish to remove. It will be seated in one of the PCIe slots.

## Disconnect the Networking Cable

To remove the networking cable, disengage the locks and slowly pull the connector away from the port receptacle. The LED indicator will turn off when the cable is unseated. Note which cables go where if they will need to be reconnected later.

## Uninstalling the PCIe Auxiliary Card

1. **Locate the PCIe Auxiliary Card:** Identify the PCIe Auxiliary card installed in the system, typically next to the SuperNIC.

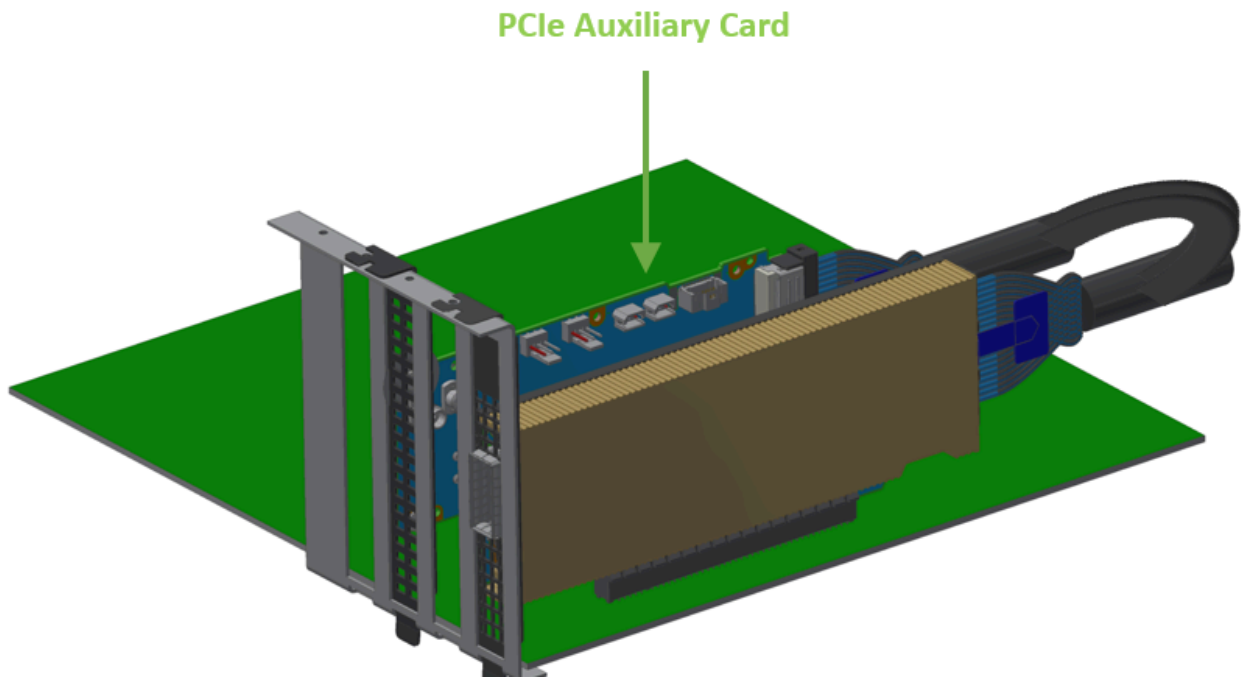

## 2. **Disconnect the MCI0 Cable:**

1. Identify the MCI0 harness that connects the PCIe Auxiliary card and the SuperNIC.
2. Gently disconnect the MCI0 harness from the SuperNIC MCI0 connector.
3. Similarly, disconnect the other end of the MCI0 harness from the PCIe Auxiliary card.
4. Once both ends are disconnected, carefully remove the MCI0 harness from the system.

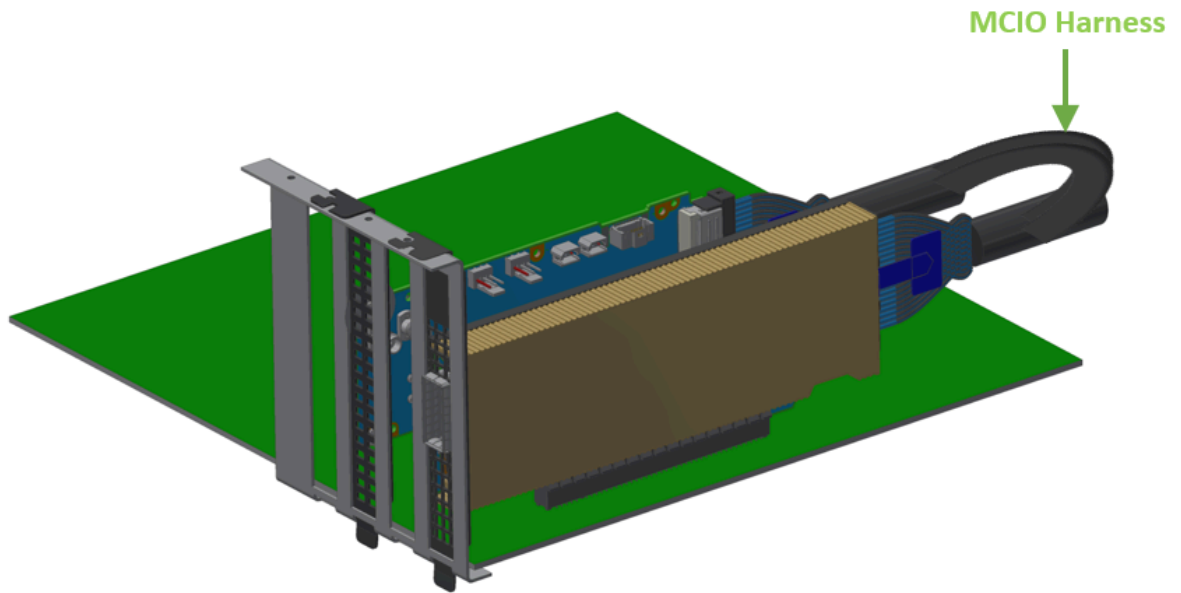

3. **Release the Retention Mechanism:** Disengage the hockey stick on the PCIe Auxiliary card bracket.

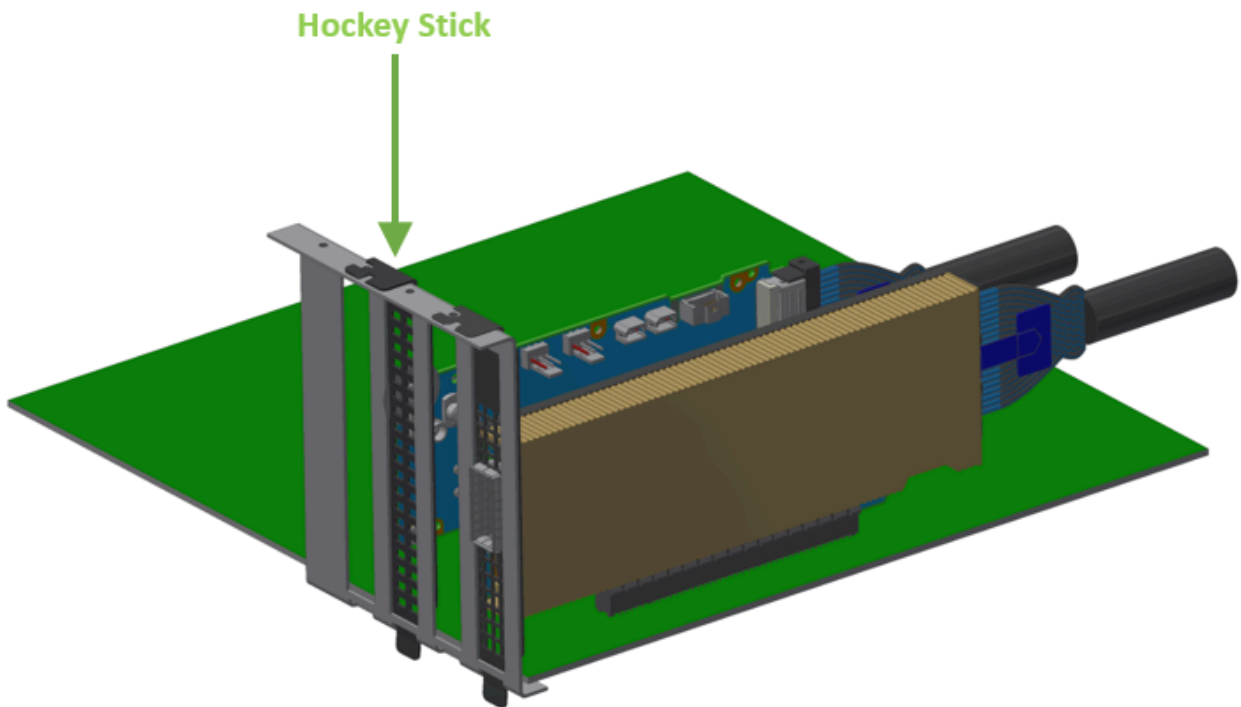

4. **Remove PCIe Card:** Carefully pull the PCIe Auxiliary card out of the PCIe slot, making sure to hold it by its edges. Avoid touching the connectors.

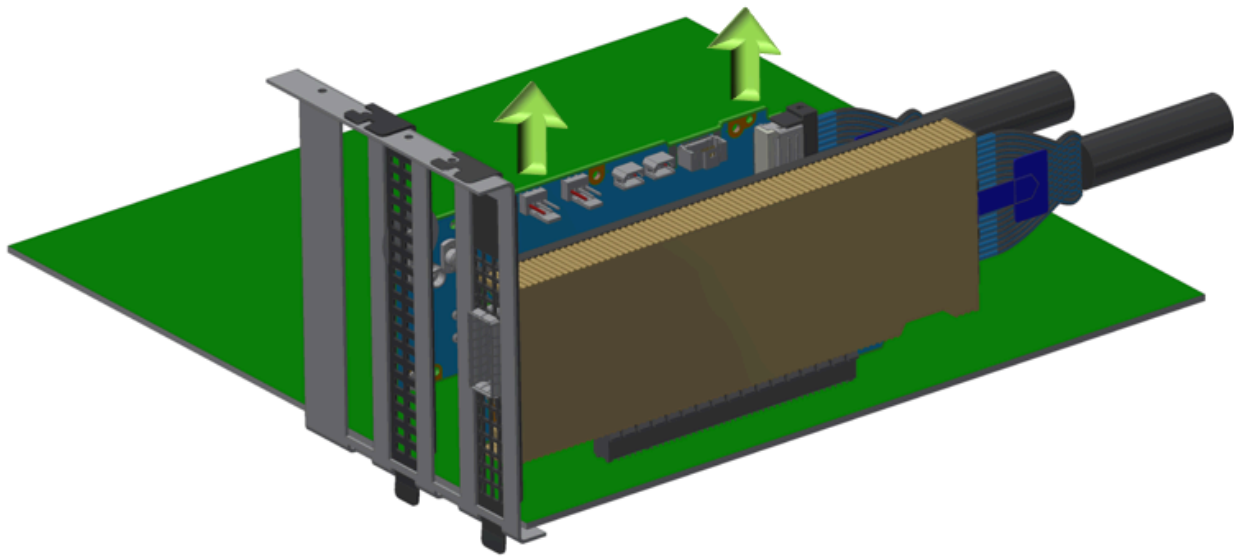

## Uninstalling the ConnectX-8 SuperNIC

1. **Disconnect Cables:** If there are any additional cables or connections to the SuperNIC (such as network cables), disconnect them.
2. **Release the SuperNIC from the Slot:** If the SuperNIC is secured in place with screws or latches (Hockey Stick), remove or release them.

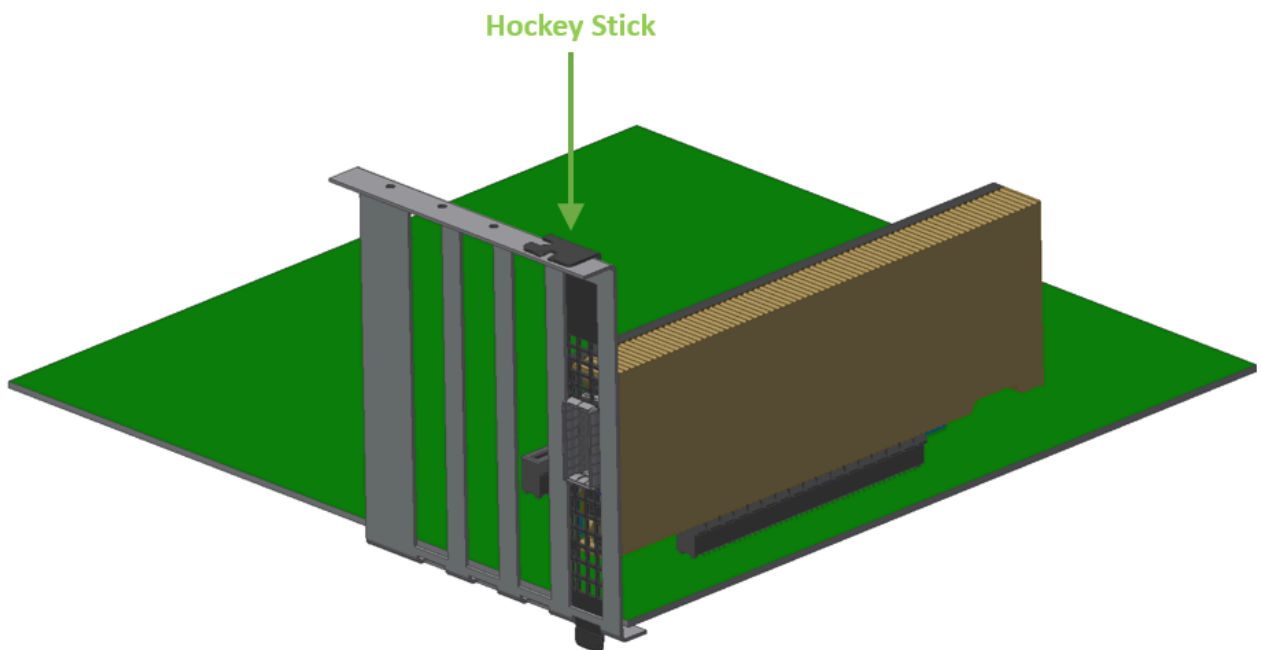

3. **Remove the SuperNIC:** Gently pull the SuperNIC from its PCIe slot, again holding it by the edges to avoid damage.

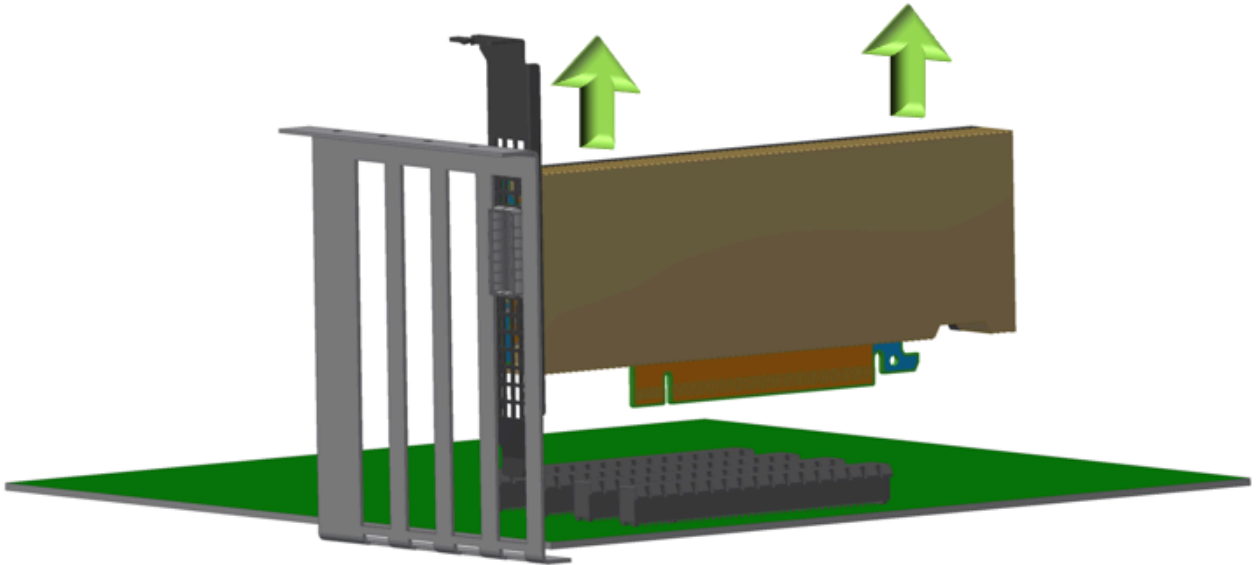

## Final Steps

1. **Check for Loose Components:** Ensure that all parts, such as screws, cables, or connectors, are safely stored and not left inside the system.
2. **Inspect for Damage:** Examine the components for any signs of physical damage that might have occurred during installation or removal.

## Dispose of Components Properly

If you plan on disposing of any of the hardware, make sure to follow your organization's disposal guidelines for electronic waste (e-waste).

---

# Driver Installation

Please refer to the relevant driver installation section.

- [DOCA-Host for Linux Driver Installation](#)
- [Windows Driver Installation](#)

## DOCA-Host for Linux Driver Installation

This section describes how to install and test the DOCA-Host for Linux package on a single server with a ConnectX-8 SuperNIC installed.

### Prerequisites

Requirements	Description
Platforms	A server platform with a ConnectX-8 SuperNIC installed.
Required Disk Space for Installation	1GB
Operating System	Linux operating system. For the list of supported operating system distributions and kernels, please refer to the <a href="#">DOCA-Host Release Notes</a> .
Installer Privileges	The installation requires administrator (root) privileges on the target machine.

### Downloading DOCA-Host

Verify that the system has a network adapter installed by running `lspci` command. The below table provides output examples per ConnectX-8 card configuration.

ConnectX-8 Card Configuration	Output Examples
<p><b>Single-port Socket Direct Card/MultiHost (2x PCIe x16)</b>            OPN: 900-9X81Q-00CN-ST0</p>	<pre>11:00.0 Infiniband controller: Mellanox Technologies CX8 Family [ConnectX-8] 59:00.0 Infiniband controller: Mellanox Technologies CX8 Family [ConnectX-8]</pre>
<p><b>Dual-port Socket Direct Card/MultiHost (2x PCIe x16)</b>            OPN: 900-9X81Q-00CN-ST0</p>	<pre>82:00.0 Ethernet controller: Mellanox Technologies CX8 Family [ConnectX-8] 82:00.1 Ethernet controller: Mellanox Technologies CX8 Family [ConnectX-8] 84:00.0 Ethernet controller: Mellanox Technologies CX8 Family [ConnectX-8] 84:00.1 Ethernet controller: Mellanox Technologies CX8 Family [ConnectX-8]</pre> <p>In the output example above, the first two rows indicate that one card is installed in a PCI slot with PCI Bus address 05 (hexadecimal), PCI Device number 00, and PCI Function numbers 0 and 1. The other card is installed in a PCI slot with PCI Bus address 82 (hexadecimal), PCI Device number 00, and PCI Function numbers 0 and 1.</p> <p>Since the two PCIe cards are installed in two PCIe slots, each card gets a unique PCI Bus and Device number. Each of the PCIe x16 busses sees two network ports; in effect, the two physical ports of the ConnectX-7 Socket Direct adapter are viewed as four net devices by the system.</p>
<p><b>Single-port with x16 PCIe Down Stream Port Extension Option</b>            OPN: 900-9X81E-00EX-DT0</p>	<pre>84:00.0 Ethernet controller: Mellanox Technologies CX8 Family [ConnectX-8]</pre>

ConnectX-8 Card Configuration	Output Examples
<b>Dual-port PCIe x16 Card</b> OPN: 900-9X81Q-00CN-ST0	<pre>82:00.0 Ethernet controller: Mellanox Technologies CX8 Family [ConnectX-8] 82:00.1 Ethernet controller: Mellanox Technologies CX8 Family [ConnectX-8]</pre>
<b>Single-port PCIe x16 Card</b> OPN: 900-9X81E-00EX-ST0	<pre>84:00.0 Ethernet controller: Mellanox Technologies CX8 Family [ConnectX-8]</pre>

For instructions on downloading DOCA-Host, refer to [NVIDIA DOCA Downloads](#).

## Installing DOCA-Host

For Linux driver installation, please refer to [NVIDIA DOCA Installation Guide for Linux](#).

# Windows Driver Installation

For Windows, download and install the latest WinOF-2 for Windows software package available via the NVIDIA website at: [WinOF-2 webpage](#). Follow the installation instructions included in the download package (also available from the download page).

The snapshots in the following sections are presented for illustration purposes only. The installation interface may slightly vary, depending on the operating system in use.

## Software Requirements

For the full list of supported operating systems, please refer to the [WinOF-2 Documentation](#) -> Release Notes.

## Downloading WinOF-2 Driver

 **To download the .exe file according to your Operating System, please follow the steps below:**

1. Obtain the machine architecture.

1. To go to the Start menu, position your mouse in the bottom-right corner of the Remote Desktop of your screen.
2. Open a CMD console (Click Task Manager-->File --> Run new task and enter CMD).
3. Enter the following command.

```
echo %PROCESSOR_ARCHITECTURE%
```

**Note**

On an x64 (64-bit) machine, the output will be “AMD64”.

2. Go to the WinOF-2 web page at: <https://www.nvidia.com/en-us/networking/> > Products > Software > InfiniBand Drivers (Learn More) > Nvidia WinOF-2.
3. Download the .exe image according to the architecture of your machine (see [Step 1](#)).

The name of the .exe is in the following format: MLNX\_WinOF2-  
<version>\_<arch>.exe.

**Note**

Installing the incorrect .exe file is prohibited. If you do so, an error message will be displayed.

For example, if you install a 64-bit .exe on a 32-bit machine, the wizard will display the following (or a similar) error message: “The installation package is not supported by this processor type. Contact your vendor”

# Installing WinOF-2 Driver

The snapshots in the following sections are for illustration purposes only. The installation interface may slightly vary, depending on the used operating system.

This section provides instructions for two types of installation procedures, and both require administrator privileges:

- [Attended Installation](#)

An installation procedure that requires frequent user intervention.

- [Unattended Installation](#)

An automated installation procedure that requires no user intervention.

## Attended Installation

The following is an example of an installation session.

1. Double click the .exe and follow the GUI instructions to install MLNX\_WinOF2.
2. **[Optional]** Manually configure your setup to contain the logs option (replace "LogFile" with the relevant directory).

```
MLNX_WinOF2_<revision_version>_All_Arch.exe /v"/l*vx  
[LogFile]"
```

3. **[Optional]** If you do not want to upgrade your firmware version (i.e., MT\_SKIPFWUPGRD default value is False).

```
MLNX_WinOF2_<revision_version>_All_Arch.exe /v" MT_SKIPFWUPGRD=1"
```

4. **[Optional]** If you do not want to install the Rshim driver, run.

```
MLNX_WinOF2_<revision_version>_All_Arch.exe /v"  
MT_DISABLE_RSHIM_INSTALL=1"
```

**Note**

The Rshim driver installation will fail if a prior Rshim driver is already installed. The following fail message will be displayed in the log:

```
"ERROR!!! Installation failed due to following errors: MlxRshim  
drivers installation disabled and MlxRshim drivers Installed,  
Please remove the following oem inf files from driver store:  
<oem inf list>"
```

5. **[Optional]** If you want to skip the check for unsupported devices, run.

```
MLNX_WinOF2_<revision_version>_All_Arch.exe /v"  
SKIPUNSUPPORTEDDEVCHECK=1"
```

6. Click Next in the Welcome screen.

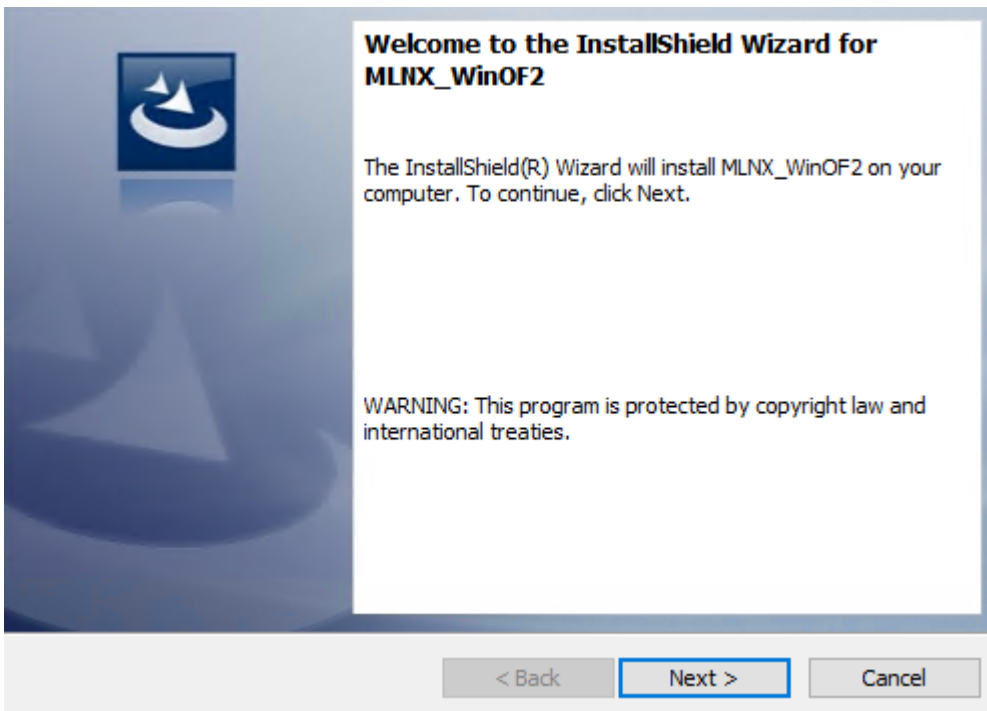

7. Read and accept the license agreement and click Next.

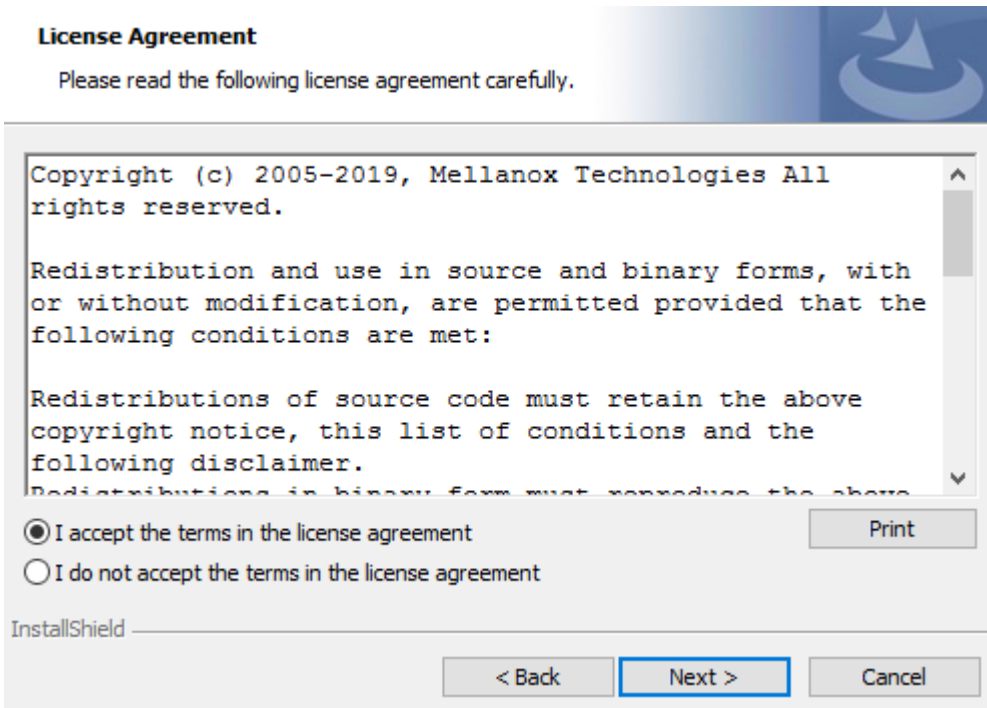

8. Select the target folder for the installation.

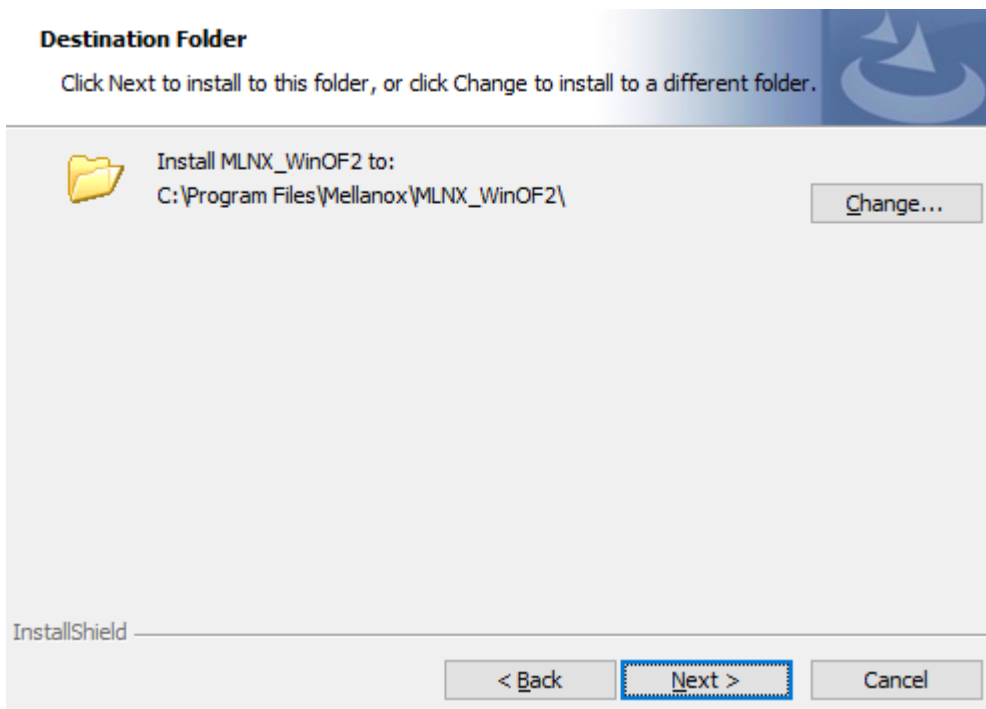

9. The firmware upgrade screen will be displayed in the following cases:

- If the user has an OEM card. In this case, the firmware will not be displayed.
- If the user has a standard NVIDIA® card with an older firmware version, the firmware will be updated accordingly. However, if the user has both an OEM card and a NVIDIA® card, only the NVIDIA® card will be updated.

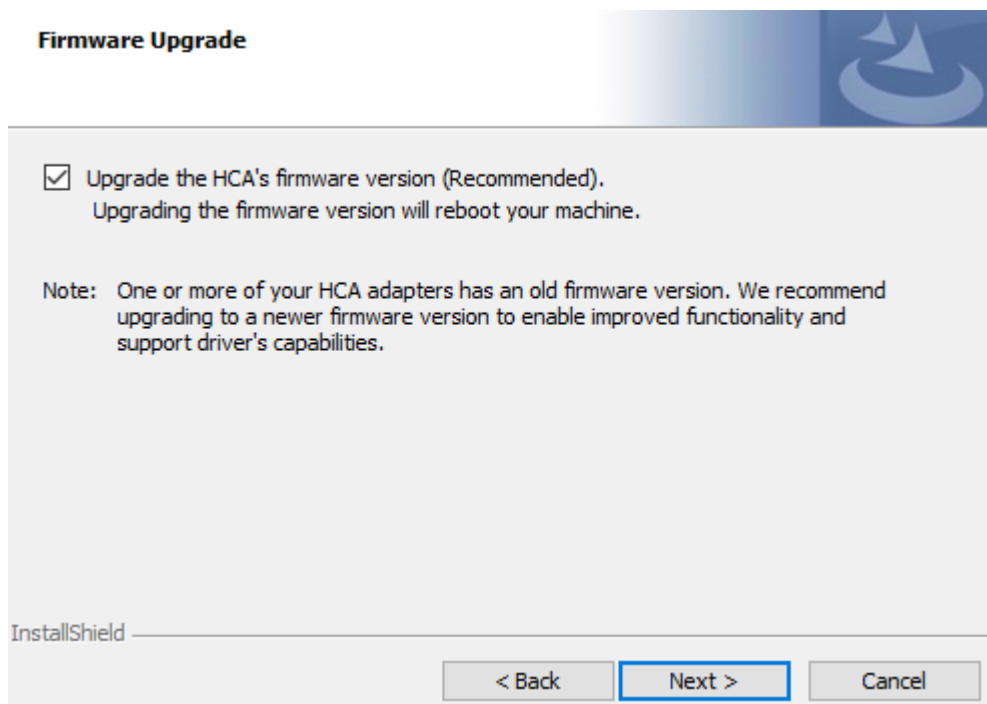

10. Select a Complete or Custom installation, follow [Step a](#) onward.

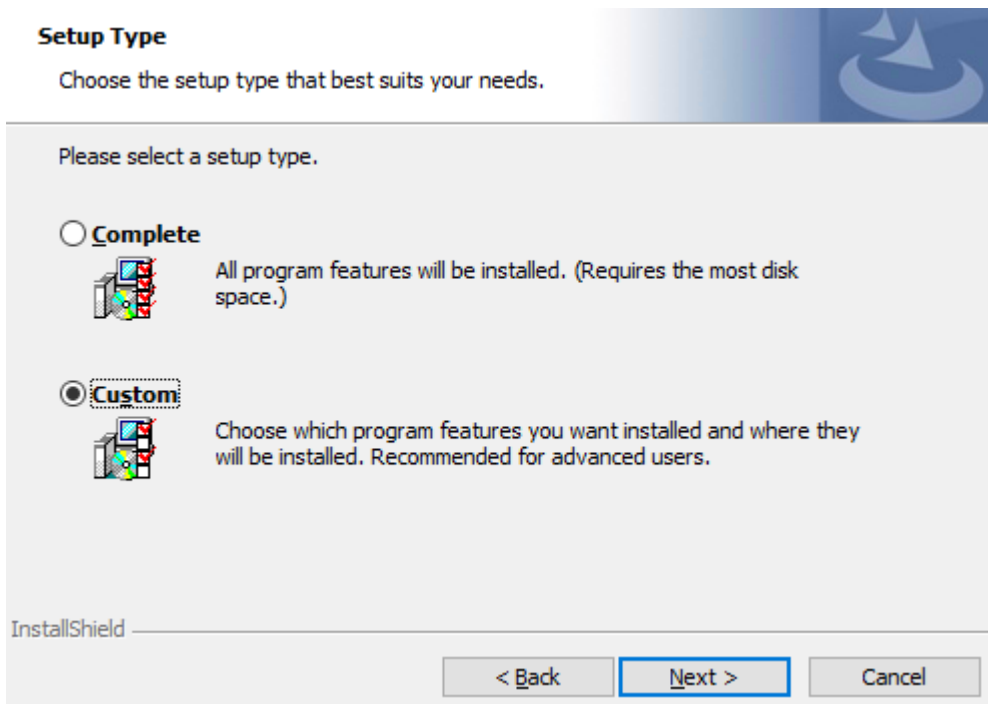

1. Select the desired feature to install:

- Performances tools - install the performance tools that are used to measure performance in user environment
- Documentation - contains the User Manual and Release Notes
- Management tools - installation tools used for management, such as mlxstat
- Diagnostic Tools - installation tools used for diagnostics, such as mlx5cmd

2. Click Next to install the desired tools.

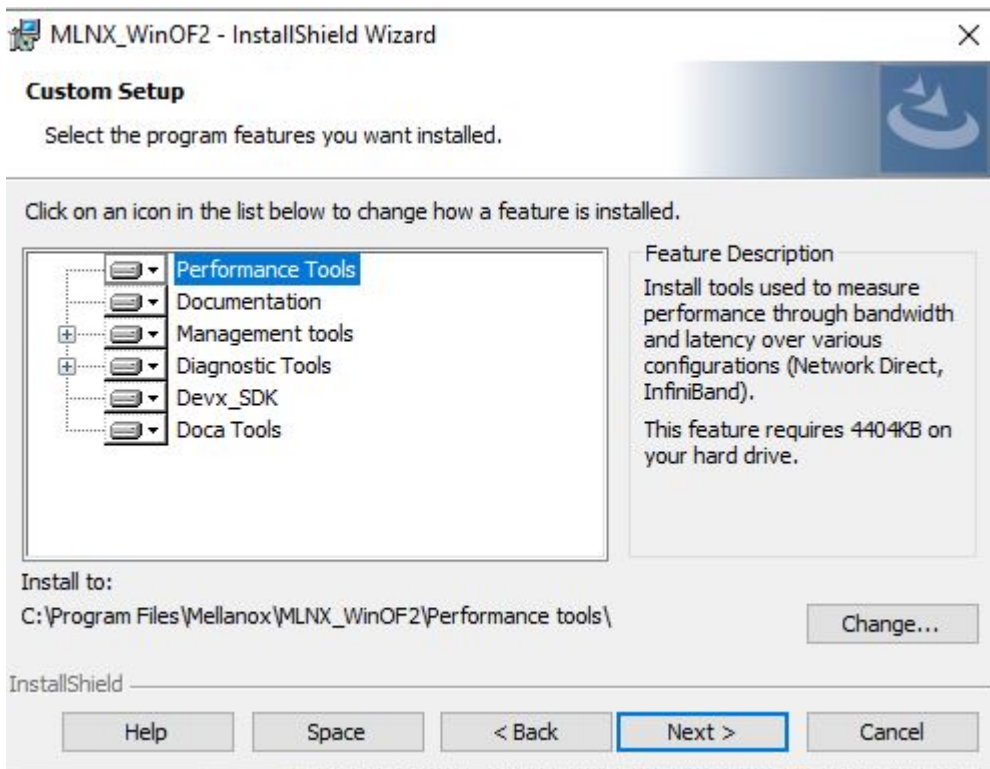

11. Click Install to start the installation.

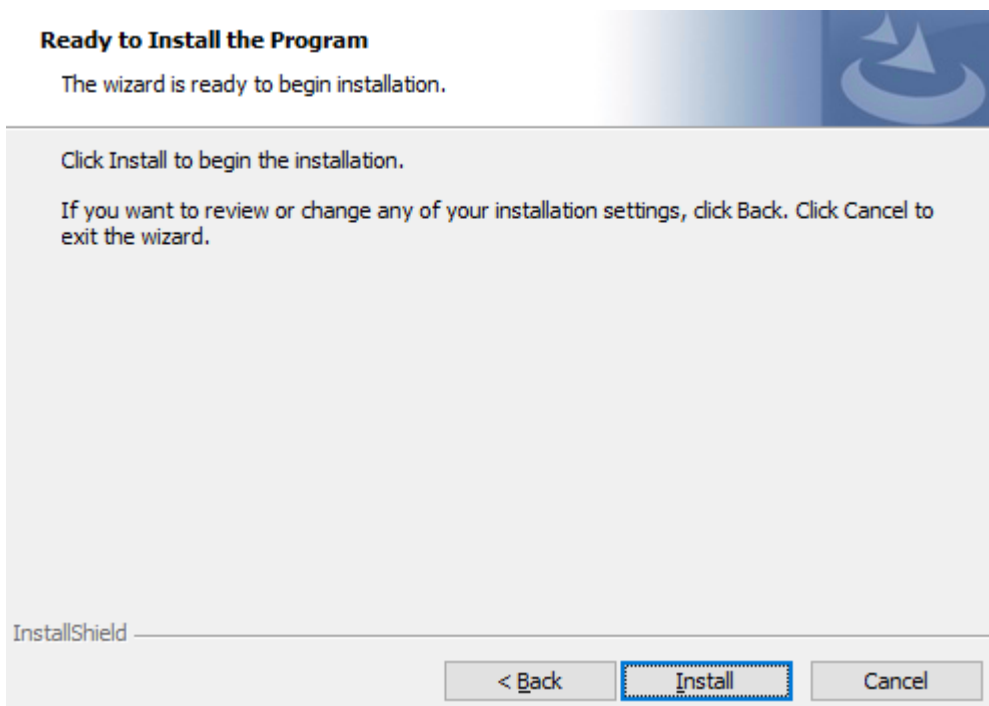

12. In case firmware upgrade option was checked in [Step 7](#), you will be notified if a firmware upgrade is required (see [images/download/thumbnails/2219580626/FW\\_upgrade\\_icon-version-1-modificationdate-1670524486073-api-v2.JPG](#)).

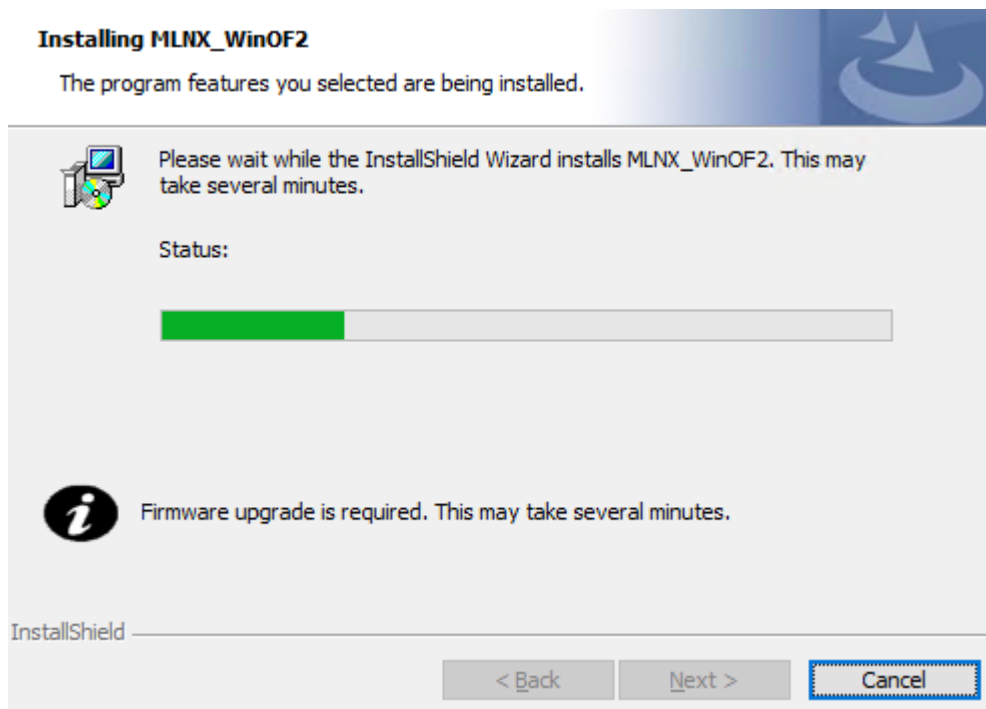

13. Click Finish to complete the installation.

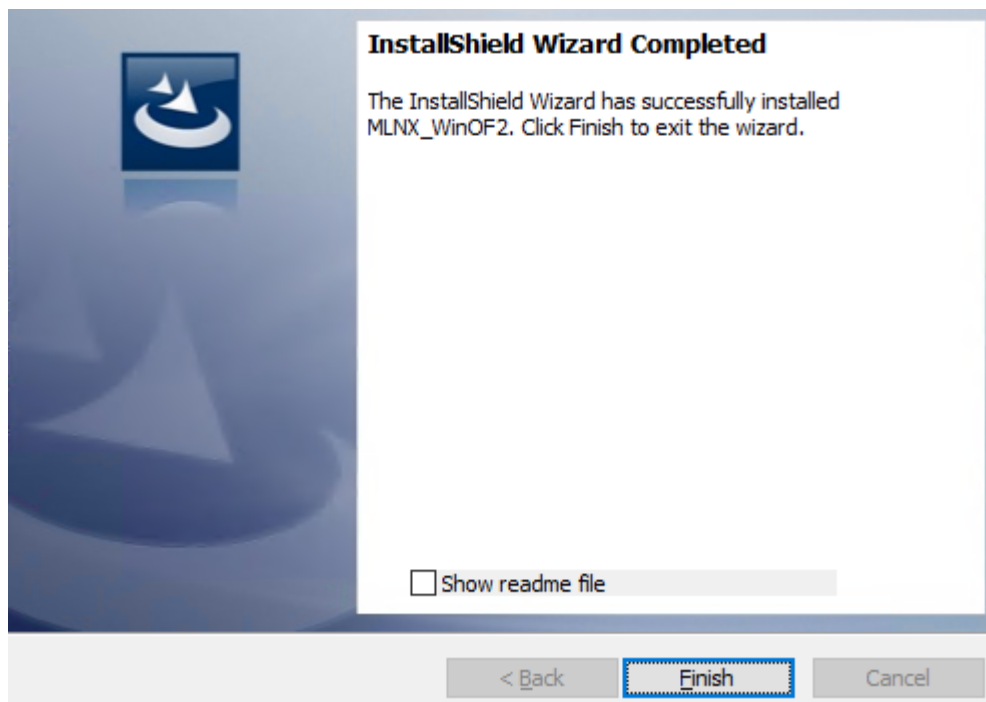

## Unattended Installation

## Note

If no reboot options are specified, the installer restarts the computer whenever necessary without displaying any prompt or warning to the user.

To control the reboots, use the */norestart* or */forcerestart* standard command-line options.

The following is an example of an unattended installation session.

1. Open a CMD console-> Click Start-> Task Manager File-> Run new task-> and enter CMD.
2. Install the driver. Run:

```
MLNX_WinOF2-[Driver/Version]_<revision_version>_All_-Arch.exe  
/S /v/qn
```

3. **[Optional]** Manually configure your setup to contain the logs option:

```
MLNX_WinOF2-[Driver/Version]_<revision_version>_All_-Arch.exe  
/S /v/qn /v"/l*v [LogFile]"
```

4. **[Optional]** if you wish to control whether to install ND provider or not (i.e., *MT\_NDPROPERTY* default value is *True*).

```
MLNX_WinOF2-[Driver/Version]_<revision_version>_All_-Arch.exe  
/vMT_NDPROPERTY=1
```

5. **[Optional]** If you do not wish to upgrade your firmware version (i.e., *MT\_SKIPFWUPGRD* default value is *False*).

```
MLNX_WinOF2-[Driver/Version]_<revision_version>_All_Arch.exe  
/vMT_SKIPFWUPGRD=1
```

6. **[Optional]** If you do not want to install the Rshim driver, run.

```
MLNX_WinOF2_<revision_version>_All_Arch.exe /v"  
MT_DISABLE_RSHIM_INSTALL=1"
```

**Note**

The Rshim driver installation will fail if a prior Rshim driver is already installed. The following fail message will be displayed in the log:

```
"ERROR!!! Installation failed due to following errors: MlxRshim  
drivers installation disabled and MlxRshim drivers Installed,  
Please remove the following oem inf files from driver store:  
<oem inf list>"
```

7. **[Optional]** If you want to enable the default configuration for Rivermax, run.

```
MLNX_WinOF2_<revision_version>_All_Arch.exe /v"MT_RIVERMAX=1 /!*vx  
C:\Users\<user>\log.txt "
```

8. **[Optional]** If you want to skip the check for unsupported devices, run/

```
MLNX_WinOF2_<revision_version>_All_Arch.exe /v"  
SKIPUNSUPPORTEDDEVCHECK=1"
```

## Firmware Upgrade

If the machine has a standard NVIDIA® card with an older firmware version, the firmware will be automatically updated as part of the NVIDIA® WinOF-2 package installation. For information on how to upgrade firmware manually, please refer to [MFT User Manual](#).

If the machine has a DDA (pass through) facility, firmware update is supported only in the Host. Therefore, to update the firmware, the following must be performed:

1. Return the network adapters to the Host.
2. Update the firmware according to the steps in the [MFT User Manual](#).
3. Attach the adapters back to VM with the DDA tools.

---

# Firmware Upgrade

Each SuperNIC is shipped with the latest version of qualified firmware at the time of manufacturing. However, NVIDIA issues firmware updates occasionally that provide new features and bug fixes. To check that your card is programmed with the latest available firmware version, download the mlxup firmware update and query utility. The utility can query for available SuperNICs and indicate which SuperNIC require a firmware update. If the user confirms, mlxup upgrades the firmware using embedded images. The latest mlxup executable and documentation are available in [mlxup - Update and Query Utility](#).

## Firmware Update Example

```
[server1]# ./mlxup
Querying Mellanox devices firmware ...
Device Type:      ConnectX-8
Part Number:      900-9X81E-00NX-ST0
Description:      NVIDIA ConnectX-8 C8180 HHL SuperNIC, 800Gbs
XDR IB (default mode) / 2x400GbE, Single-cage OSFP, PCIe 6 x16
with x16 PCIe extension option, Crypto Disabled, Secure Boot
Enabled, Tall bracket
PCI Device Name:  0b:00.0
Base MAC:         0000e41d2d5cf810
Versions:         Current      Available
FW                28.33.0800    28.33.1000
Status:           Update required

Device Type:      ConnectX-8
Part Number:      900-9X81E-00NX-ST0
Description:      NVIDIA ConnectX-8 C8180 HHL SuperNIC, 800Gbs
XDR IB (default mode) / 2x400GbE, Single-cage OSFP, PCIe 6 x16
with x16 PCIe extension option, Crypto Disabled, Secure Boot
Enabled, Tall bracket
Base MAC:         0000e41d2d5cf810
```

Versions:	Current	Available
FW	28.33.0800	28.33.1000
Status:	Up to date	

Perform FW update? [y/N]: y

Device #1: Up to date

Device #2: Updating FW ... Done

Restart needed for updates to take effect.

Log File: /var/log/mlxup/mlxup-yyyymmdd.log

---

# SuperNIC Configurations

- [Setting High-Speed-Port Link Type](#)
- [PCIe Bifurcation Configuration Options](#)
- [Port Splitting Configurations](#)
- [Monitoring](#)

## Setting High-Speed-Port Link Type

The following table lists the supported speeds per SuperNIC OPN, and their default networking port link type .

OPN	Data Transmission Rate	Default Protocol and Rate
900-9X81E-00EX-ST0	2x400GbE / 800Gbs XDR	InfiniBand XDR
900-9X81E-00EX-DT0	2x400GbE / 800Gbs XDR	InfiniBand XDR
900-9X81Q-00CN-ST0	400GbE / NDR	Ethernet 400GbE

You can use the [mlxconfig](#) or the [UEFI](#) tools to configure the networking high-speed ports mode.

Use the UEFI tool to configure the SuperNIC before the operating system is up. Use the [mlxconfig](#) tool to configure the SuperNIC once the operating system is up. According to your preference, use one of the below tools:

### mlxconfig

The [mlxconfig](#) tool allows users to change device configurations without burning the firmware. The configuration is also kept after reset. By default, [mlxconfig](#) shows the configurations that will be loaded in the next boot. For more information and instructions, refer to [Using mlxconfig to Set IB/ETH Parameters](#).

### UEFI

PreBoot drivers initialize the SuperNIC, check the port protocol type – Ethernet or InfiniBand - and bring up the port. Then, it connects to a DHCP server to obtain its assigned IP address and network parameters and the source location of the kernel/OS from which to boot. The DHCP server instructs the PreBoot drivers to access the kernel/OS through a TFTP server, an iSCSI target, or some other service. For more information and instructions, refer to [UEFI](#).

## PCIe Bifurcation Configuration Options

The ConnectX-8 SuperNICs provide a range of configuration scenarios to meet the demands of environments and deployments. This section describes the various connectivity options for peripherals on the PCIe, including scenarios where the SuperNIC acts as the PCIe switch with NVMe SSDs as PCIe endpoints. While this list of scenarios is not exhaustive, it highlights the tested and verified options. Customers seeking to support unlisted configurations should contact NVIDIA Support.

The SuperNIC exposes two x16 PCIe interfaces, with internal PCIe switch architecture. The first interface is exposed via the x16 PCIe Gen6 Goldfinger connector and serves as an endpoint to the host server by default. The additional PCIe x16 interface is exposed through the MCIO connector, featuring programmable bifurcation as a downstream port. The following figure demonstrates the SuperNIC block diagram with the PCIe interfaces.

The various configuration scenarios listed in this section include a diagram and instructions on how to bifurcate the PCIe interface using the `mlxconfig` tool. For more information on the `mlxconfig` tool, please refer to [mlxconfig – Changing Device Configuration Tool](#).

Before setting the desired configuration, take note of the following warnings:

- Any customer-set configuration overrides the previous configuration values.
- Misconfiguration may harm the system.
- It is recommended to establish out-of-band connectivity to the SuperNIC before setting any of these configurations for the first time. This enables you to reset the NVConfig parameters to their default values in case of misconfiguration.

The following summarizes the available configuration scenarios.

**The default configuration is Gen6 x16.**

**For the recommended configuration: 2x PCIe x16 supporting Gen5**

1. Execute the following commands to configure the PCIe interface:

```
mlxconfig -d /dev/mst/mt4131_pciconf0 set PCI_BUS00_WIDTH=5
mlxconfig -d /dev/mst/mt4131_pciconf0 set PCI_BUS00_SPEED=4
mlxconfig -d /dev/mst/mt4131_pciconf0 set
PCI_BUS00_HIERARCHY_TYPE=0
mlxconfig -d /dev/mst/mt4131_pciconf0 set PCI_BUS10_WIDTH=5
mlxconfig -d /dev/mst/mt4131_pciconf0 set PCI_BUS10_SPEED=4
mlxconfig -d /dev/mst/mt4131_pciconf0 set
PCI_BUS10_HIERARCHY_TYPE=0
```

2. Reboot or power cycle the system.

### **To change back to the INI default configuration: 1x PCIe x16 supporting Gen6**

1. Execute the following commands to configure the PCIe interface:

```
mlxconfig -d /dev/mst/mt4131_pciconf0 reset
```

2. Reboot or power cycle the system.

## **Port Splitting Configurations**

ConnectX-8 SuperNICs offer a variety of network port configurations designed to meet the demands of different environments and deployments. This section outlines the available connectivity options for network ports per product model. While the configurations listed here are not exhaustive, they represent the tested and verified options. Customers seeking to support unlisted configurations should contact NVIDIA Support.

The Port Splitting feature allows a single physical networking module (QSFP112 or OSFP) to be split into multiple network ports. This provides flexibility in optimizing port configurations for various network topology use cases.

### **Key Features**

- **Flexibility and Improved Traffic Segmentation:** Port splitting enables network administrators to align device ports with their network infrastructure, enabling traffic segmentation and isolation.
- **Increased Network Efficiency:** By optimizing traffic flow and reducing congestion, port splitting improves overall network efficiency. Specific physical ports can be assigned to handle certain traffic types or applications, allowing control and performance tuning.
- **Better Utilization of Resources:** Instead of needing separate SuperNICs for each logical connection or network interface, port splitting allows a single physical SuperNIC to handle multiple functions. This reduces hardware costs while maintaining high network flexibility.

## Use Cases

- **Load Balancing:** Distributing traffic across multiple physical ports can improve network load distribution and balance.
- **Resiliency :** Multiple physical ports can be used for redundancy, ensuring stable network connections even if one port encounters an issue.

Each configuration in this section includes a diagram and instructions on splitting the network port using the [mlxconfig](#) or the [UEFI](#) tools. The UEFI tool configures the device before the operating system is up, while [mlxconfig](#) configures the device once the operating system is up. Select the tool based on your preference; the configuration is saved across reboots.

**mlxconfig:** The [mlxconfig](#) tool allows users to change configurations without burning the firmware. The configuration is also kept after reset. By default, [mlxconfig](#) shows the configurations that will be loaded in the next boot. For more information and instructions, refer to [mlxconfig](#).

**UEFI:** PreBoot drivers initialize the adapter device, check the port protocol type – Ethernet or InfiniBand - and bring up the port. Then it connects to a DHCP server to obtain its assigned IP address and network parameters and obtain the source location of the kernel/OS to boot from. The DHCP server instructs the PreBoot drivers to access the kernel/OS through a TFTP server, an iSCSI target, or some other service. For more information and instructions, refer to [UEFI](#).

## **Warning**

Before setting the desired configuration, take note of the following warnings:

- Any new configuration set by the customer overwrites the previous configuration.
- Misconfiguration can potentially damage the system.
- It is recommended to establish out-of-band connectivity to the ConnectX-8 SuperNIC before setting any configuration for the first time. This allows resetting the NVConfig parameters to their default values in case of misconfiguration.
- When switching from one non-default configuration to another, it is advised to first reset the device to its default configuration. This action deletes all current NVConfig settings. For the reset command and further details, refer to the [mlxconfig – Changing Device Configuration Tool](#).

The following table summarizes the available port-splitting configurations.

Model	OPNs	Configuration	Configuration Description
C8180	900-9X81E-00NX-ST0 900-9X81E-00EX-ST0	<a href="#">Configuration #1 (Default)</a>	One InfiniBand port supporting XDR 800Gb/s
		<a href="#">Configuration #2</a>	Two Ethernet ports, each supporting 400GbE
		<a href="#">Configuration #3</a>	Eight Ethernet ports, each supporting 100GbE
C8240	900-9X81Q-00CN-ST0	<a href="#">Configuration #1 (Default)</a>	Two Ethernet ports, each supporting 400GbE
		<a href="#">Configuration #2</a>	Eight Ethernet ports, each supporting 100GbE

## **C8180 Port-Splitting Configurations**

The C8180 ConnectX-8 SuperNIC, featuring a single-port OSFP module, supports up to 800Gb/s. For the reconfiguration to take effect, please perform power cycle.

### **C8180 Configuration #1 (Default): One InfiniBand Port, Supporting XDR 800Gb/s**

As the default configuration, the device is configured with a single InfiniBand port, providing an InfiniBand XDR rate of 800Gb/s that operates as four times 200G/s . The configuration is illustrated in the diagram below.

# ConnectX-8 SuperNIC

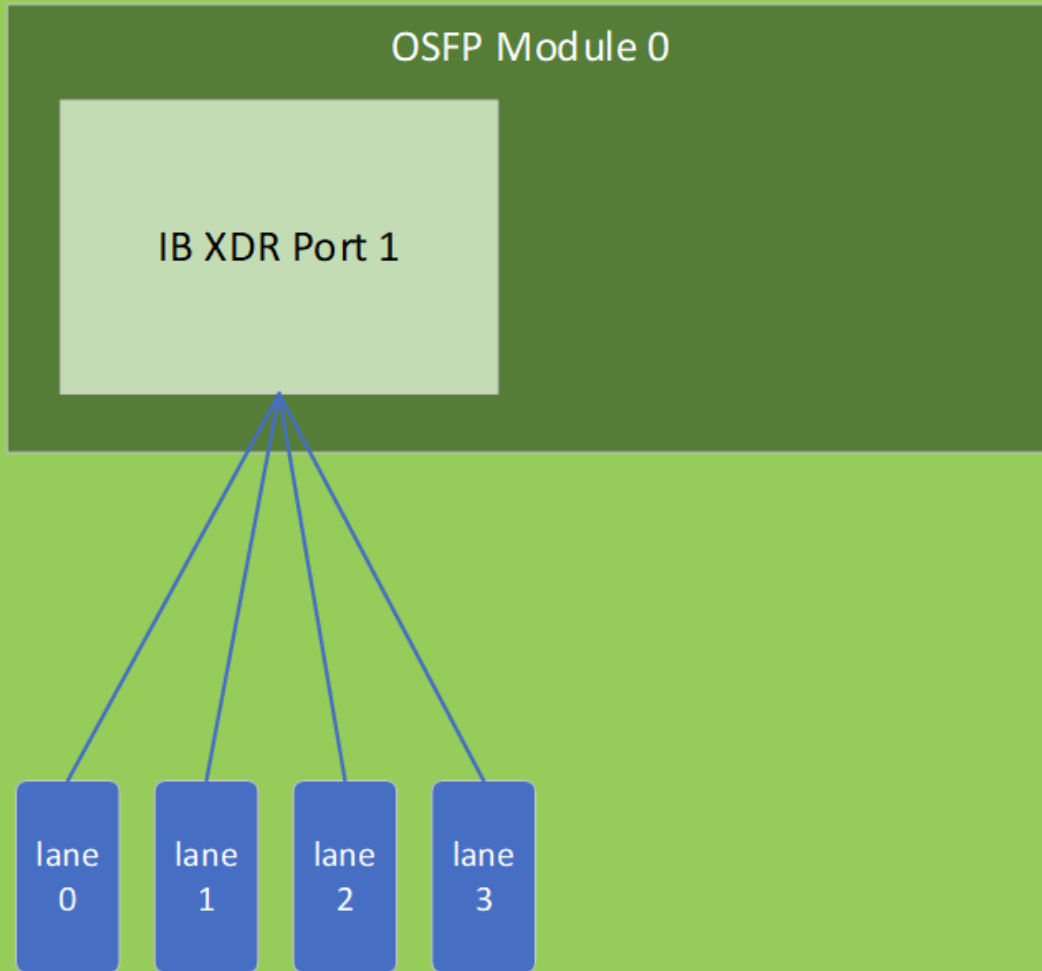

## C8180 Configuration #2: Two Ethernet Ports, Each Supporting 400GbE

In this configuration, the device can be reconfigured to support two 400GbE Ethernet ports. The configuration is illustrated in the diagram below.

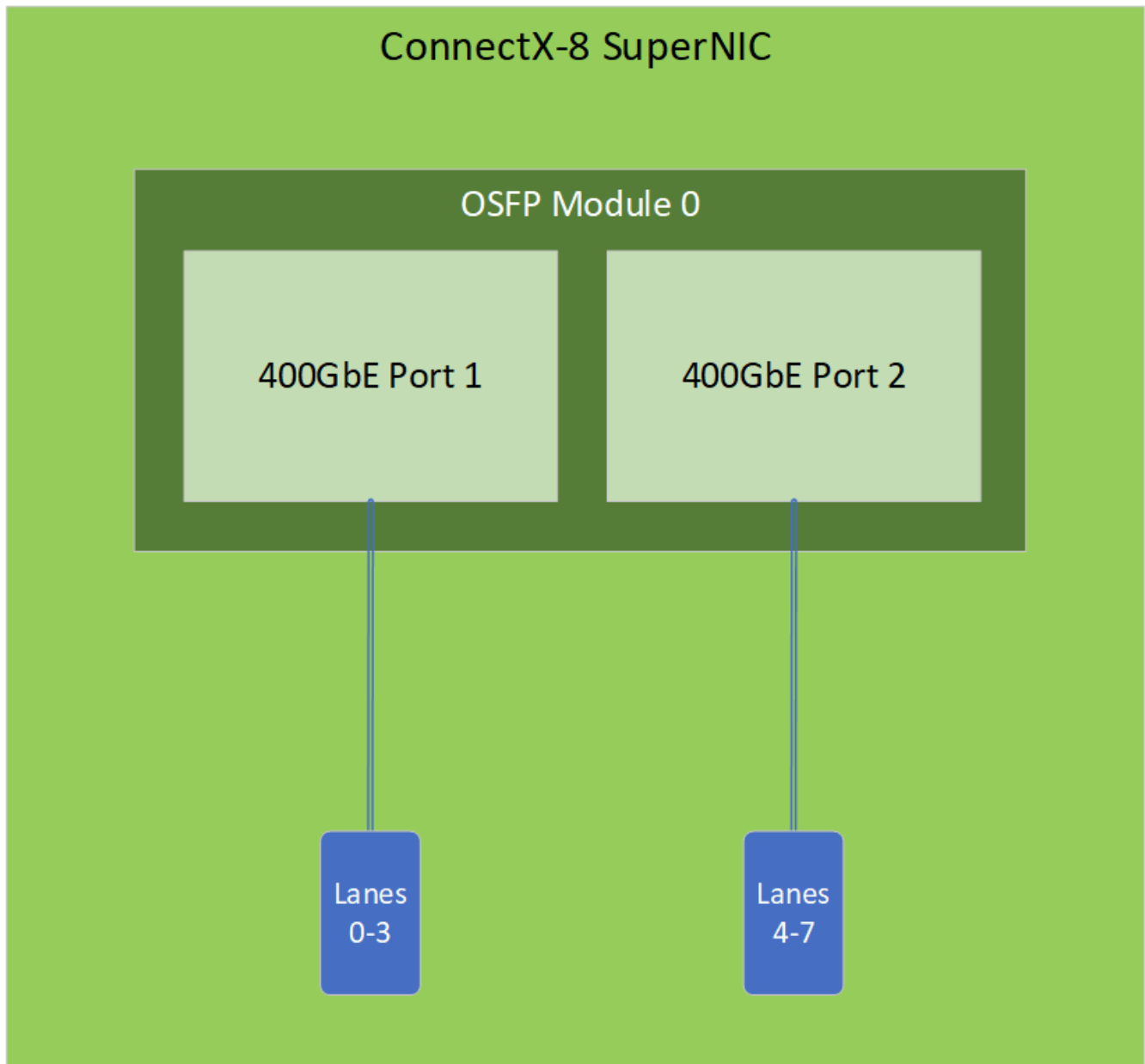

To apply this configuration, use the following mlxconfig commands:

```
mlxconfig -d <device> set LINK_TYPE_P1=2
mlxconfig -d <device> set NUM_OF_PLANES_P1 = 0
mlxconfig -d <device> set MODULE_SPLIT_M0[0..3]=1
MODULE_SPLIT_M0[4..7]=2 MODULE_SPLIT_M0[8..15]=FF
mlxconfig -d <device> set NUM_OF_PF = 2
```

## C8180 Configuration #3: Eight Ethernet Ports, Each Supporting 100GbE

In this configuration, the device can be configured to support eight 100GbE Ethernet ports. The configuration is illustrated in the diagram below.

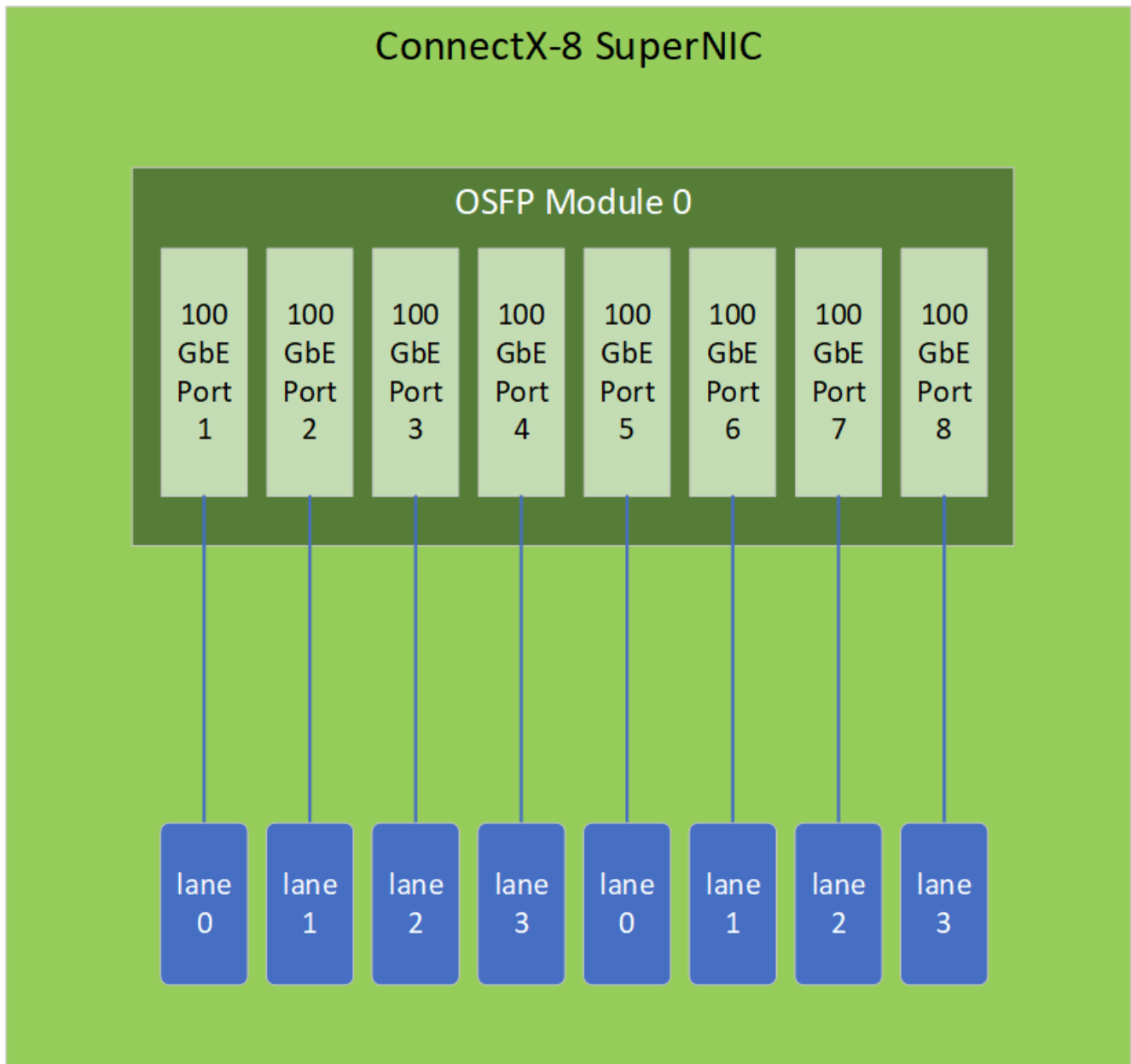

To enable this configuration, use the following mlxconfig commands:

```
mlxconfig -d <device> set LINK_TYPE_P1=2
mlxconfig -d <device> set NUM_OF_PLANES_P1 = 0
mlxconfig -d <device> set MODULE_SPLIT_M0[0]=1
MODULE_SPLIT_M0[1]=2 MODULE_SPLIT_M0[2]=3 MODULE_SPLIT_M0[3]=4
MODULE_SPLIT_M0[4]=5 MODULE_SPLIT_M0[5]=6 MODULE_SPLIT_M0[6]=7
MODULE_SPLIT_M0[7]=8 MODULE_SPLIT_M0[8..15]=FF
mlxconfig -d <device> set NUM_OF_PF = 8
```

## **C8240 Port-Splitting Configurations**

The C8240 ConnectX-8 SuperNIC, featuring dual QSFP modules, supports up to 400Gb/s per port. For the reconfiguration to take effect, please perform power cycle.

### **C8240 Configuration #1 (Default): Two Ethernet Ports, Each Supporting 400GbE**

By default, the device is configured with two Ethernet ports, each supporting a data rate of 400Gb/s. The configuration is illustrated in the diagram below.

## ConnectX-8 SuperNIC

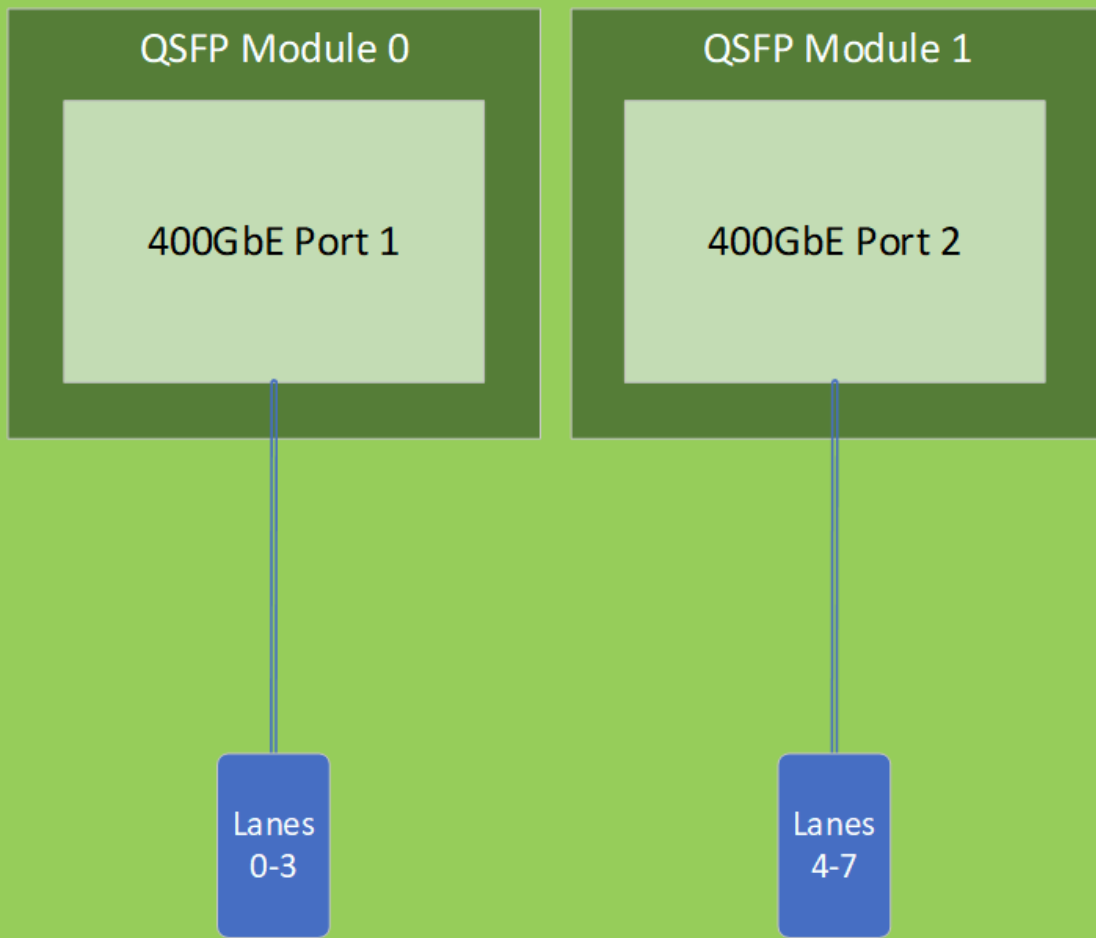

## C8240 Configuration #2: Eight Ethernet Ports, Each Supporting 100GbE

In this configuration, the device can be configured to support eight 100GbE Ethernet ports, with four ports per module. The configuration is illustrated in the diagram below.

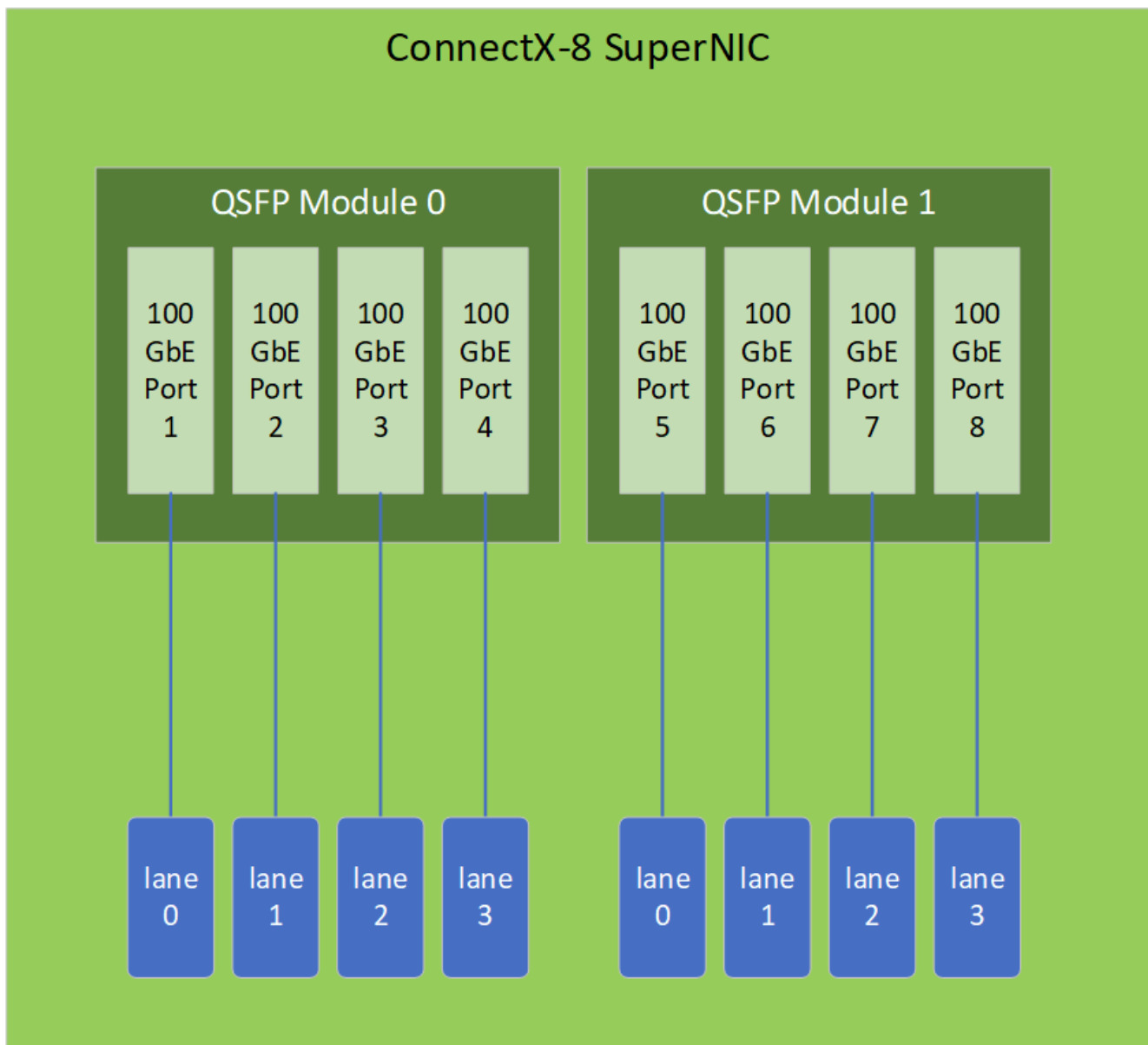

To apply this configuration, use the following mlxconfig commands:

```
m1xconfig -d <device> set MODULE_SPLIT_M0[0]=1
MODULE_SPLIT_M0[1]=2 MODULE_SPLIT_M0[2]=3 MODULE_SPLIT_M0[3]=4
MODULE_SPLIT_M0[4..15]=FF
m1xconfig -d <device> set MODULE_SPLIT_M1[0]=1
MODULE_SPLIT_M1[1]=2 MODULE_SPLIT_M1[2]=3 MODULE_SPLIT_M1[3]=4
MODULE_SPLIT_M1[4..15]=FF
```

# Monitoring

## Thermal Sensors

The adapter card incorporates the ConnectX IC, which operates in the range of temperatures between 0°C and 105°C.

Three thermal threshold definitions impact the overall system operation state and are designed to ensure timely application of server-level corrective actions, such as increased cooling, to keep the device temperature in the working range:

- **Warning** – 97°C (default) When the device crosses this threshold, an Over-Temperature Warning message is issued by the management SW. This may be used to increase the cooling of the system (e.g. - by increased Fans RPM). Note that this temperature threshold does not require nor lead to any action by hardware (such as adapter card shutdown).
- **Critical** – 102°C (default): When the device crosses this threshold, an Over-Temperature Critical message is issued by the management SW.
- **Fatal** – 110°C: Upon reaching this temperature, an Over-temperature Fatal message is issued. If the the device continues to heat-up, the FW will automatically shut down upon reaching 115°C threshold.

The card's thermal sensors can be read through the system's SMBus. The user can read these thermal sensors and adapt the system airflow following the readouts and the needs of the above-mentioned IC thermal requirements.

## SuperNIC Heatsink

The heatsink is attached to the SuperNIC IC to dissipate the heat from the IC. It is attached by spring-loaded screws.

The SuperNIC IC has a thermal shutdown safety mechanism that automatically shuts down the card in cases of high-temperature events, improper thermal coupling, or heatsink removal.

For the required airflow (LFM) per OPN, please refer to the [Specifications](#) chapter.

---

# Troubleshooting

When working with the ConnectX-8 SuperNIC, you may encounter various issues related to connectivity, performance, or configuration. This section outlines common problems, their possible causes, and steps to resolve them.

## General Troubleshooting

NIC Not Detected by the System	<ul style="list-style-type: none"><li>• Ensure that the SuperNIC is placed correctly</li><li>• Make sure the SuperNIC slot and the SuperNIC are compatible Install the SuperNIC in a different PCI Express slot</li><li>• Use the drivers that came with the SuperNIC or download the latest</li><li>• Make sure your motherboard has the latest BIOS</li><li>• Try to reboot the server</li></ul>
The SuperNIC no longer works	<ul style="list-style-type: none"><li>• Reseat the SuperNIC in its slot or a different slot, if necessary</li><li>• Try using another cable</li><li>• Reinstall the drivers for the network driver files may be damaged or deleted</li><li>• Reboot the server</li></ul>
SuperNICs stopped working after installing another SuperNIC	<ul style="list-style-type: none"><li>• Try removing and re-installing all SuperNICs</li><li>• Check that cables are connected properly</li><li>• Make sure your motherboard has the latest BIOS</li></ul>
Link indicator light is off	<ul style="list-style-type: none"><li>• Try another port on the switch</li><li>• Make sure the cable is securely attached</li><li>• Check you are using the proper cables that do not exceed the recommended lengths</li><li>• Verify that your switch and SuperNIC port are compatible</li></ul>

Link light is on, but with no communication established	<ul style="list-style-type: none"> <li>• Check that the latest driver is loaded</li> <li>• Check that both the SuperNIC and its link are set to the same speed and duplex settings</li> </ul>
---	---

## Linux Troubleshooting

Environment Information	<pre>cat /etc/issue uname -a cat /proc/cupinfo   grep 'model name'   uniq ofed_info -s ifconfig -a ip link show ethtool &lt;interface&gt; ethtool -i &lt;interface_of_Mellanox_port_num&gt; ibdev2netdev</pre>
SuperNIC Detection	<pre>lspci   grep -i Mellanox</pre>
Mellanox Firmware Tool (MFT)	<p>Download and install MFT: <a href="#">MFT Documentation</a>  Refer to the User Manual for installation instructions.  Once installed, run:</p> <pre>mst start mst status flint -d &lt;mst_device&gt; q</pre>
Ports Information	<pre>ibstat ibv_devinfo</pre>
Firmware Version Upgrade	<p>To download the latest firmware version, refer to the <a href="#">NVIDIA Update and Query Utility</a>.</p>
Collect Log File	<pre>cat /var/log/messages dmesg &gt;&gt; system.log journalctl (Applicable on new operating systems) cat /var/log/syslog</pre>

## Windows Troubleshooting

Environment Information	<p>From the Windows desktop choose the Start menu and run:</p> <pre>msinfo32</pre> <p>To export system information to a text file, choose the Export option from the File menu.  Assign a file name and save.</p>
-------------------------	---

Mellanox Firmware Tool (MFT)	<p>Download and install MFT: <a href="#">MFT Documentation</a>  Refer to the User Manual for installation instructions.  Once installed, open a CMD window and run:</p> <pre>WinMFT mst start mst status flint -d &lt;mst_device&gt; q</pre>
Ports Information	<pre>vstat</pre>
Firmware Version Upgrade	<p>Download the latest firmware version using the PSID/board ID from <a href="#">here</a>.</p> <pre>flint -d &lt;mst_device&gt; -i &lt;firmware_bin_file&gt; b</pre>
Collect Log File	<ul style="list-style-type: none"> <li>• Event log viewer</li> <li>• MST device logs: <ul style="list-style-type: none"> <li>◦ mst start</li> <li>◦ mst status</li> </ul> </li> <li>• <code>flint -d &lt;mst_device&gt; dc &gt; dump_configuration.log</code></li> <li>• <code>mstdump &lt;mst_device&gt; dc &gt; mstdump.log</code></li> </ul>

---

# Finding the GUID/MAC on the SuperNIC

Each SuperNIC is labeled with unique identifiers, including a serial number and specific protocol information; it includes a GUID (for InfiniBand protocols) and a MAC address (for Ethernet protocols, derived from the GUID).

## Note

The product revisions indicated on the labels in the following figures do not necessarily represent the latest revisions of the SuperNICs.

### Board Label Example





## Guidelines for Adding Customized Product Labels on NVIDIA Networking Products

If customers wish to add customized labels on NVIDIA generic products (in addition to the original labels), the following NVIDIA label placement guidelines should be observed. These guidelines are intended to prevent damaging the products, voiding the warranty, and/or creating safety hazards.

- **Preserve Existing Labels:** Do not cover, remove, or alter the existing labels. Doing so may impact the performance, safety, or warranty of the products.
- **Use Appropriate Labels:** Select labels that are easily removable, scannable and compatible with the material, shape, and size of the products. Do not use glue that may leave marks or damage the product.
- **Proper Label Placement:** Apply labels only to areas **without** existing labels and where they do not interfere with electronic components, cooling elements, or other features requiring ventilation, heat dissipation, or insulation. For example, avoid placing labels on fans, heatsinks, cages, mylar, batteries, power cords, switches, buttons, or connectors.
- **Careful Application:** Apply labels smoothly to avoid wrinkles, bubbles, or gaps. Do not use tools or force, as this may damage the products or labels.
- **Regular Inspection:** Regularly check the labels for signs of wear, tear, or peeling. Replace or remove any labels that are damaged, faded, or loose.

- **Adhere to Instructions:** Follow all instructions and warnings provided with the products and labels. Use the products and labels as intended, adhering to the specifications and safety precautions.
- **Return Merchandise Authorization (RMA):** If you need to return the product to NVIDIA and initiate an RMA process, please remove any customer-customized labels and return the product with its original labels. For more information, refer to [Checklist Before Submitting an RMA Request](#).

---

# Specifications

## **Warning**

The ConnectX-8 SuperNIC is designed and validated for operation in data-center servers and other large environments that guarantee proper power supply and airflow conditions.

The SuperNIC is not intended for installation on a desktop or a workstation. Moreover, installing the adapter card in any system without proper power and airflow levels can impact the SuperNIC's functionality and potentially damage it. Failure to meet the environmental requirements listed in this user manual may void the warranty.

## **Note**

Please install the ConnectX-8 SuperNIC in a PCIe slot capable of supplying the required power and airflow.

# C8180 SuperNICs Specifications

## Note

ConnectX-8 SuperNICs with OSFP form factor support RHS (Riding Heatsink) cage only

<b>Physical</b>	SuperNIC Dimensions: PCIe Half Height, Half Length 2.69 in. x 6.58 in. (68.50mm x 168.40mm)	
<b>Interfaces</b>	See <a href="#">Supported Interfaces</a>	
	PCI Express Interface	Gen6 SERDES @ 64GT/s, x16 lanes (Gen 5 compatible)
		<b>Optional:</b> Additional PCIe x16 Gen5 @ SERDES 32GT/s through the PCIe auxiliary card and MCIO harness
Networking Port: Single cage OSFP InfiniBand and Ethernet		
<b>Data Rate</b>	InfiniBand (Default)	XDR/NDR/HDR/HDR100/EDR/SDR
	Ethernet	400/200/100 Gb/s Ethernet
<b>Protocol Support</b>	InfiniBand: IBTA v1.7 <sup>a</sup> Auto-Negotiation: XDR (4 lanes x 200Gb/s per ) port, NDR (4 lanes x 100Gb/s per lane) port, NDR200 (2 lanes x 100Gb/s per lane) port, HDR (50Gb/s per lane) port, HDR100 (2 lane x 50Gb/s per lane) port, EDR (25Gb/s per lane) port, FDR (14.0625Gb/s per lane), 1X/2X/4X SDR (2.5Gb/s per lane).	
	Ethernet: 400GAUI-4 C2M, 400GBASE-CR4, 200GAUI-2 C2M, 200GAUI-4 C2M, 200GBASE-CR4, 100GAUI-2 C2M, 100GAUI-1 C2M, 100GBASE-CR4, 100GBASE-CR2, 100GBASE-CR1, 50GAUI-2 C2M, 50GAUI-1 C2M, 50GBASE-CR, 50GBASE-R2 , 40GBASE-CR4, 40GBASE-R2, 25GBASE-R, 10GBASE-R, 10GBASE-CX4, 1000BASE-CX, CAUI-4 C2M, 25GAUI C2M, XLAUI C2M , XLPPI, SFI	
<b>Capabilities</b>	900-9X81Q-00CN-STO	Secure Boot Enabled, Crypto Enabled with x16 PCIe extension option

	900-9X81E-00EX-DT0	Secure Boot Enabled, Crypto Enabled with x16 PCIe Down-Stream Port Extension Option	
Electrical and Thermal Specifications	Voltage: 12V, 3.3V, 3.3VAUX		
	The complete electrical and thermal specifications are provided in " <i>NVIDIA ConnectX-8 SuperNIC Product Specifications</i> " document. You can access the document either by logging into NVOnline or by contacting your NVIDIA representative.		
<b>Environmental</b>	Temperature	Operational	0°C to 55°C
		Non-operational	-40°C to 70°C <sup>b</sup>
	Humidity	Operational	10% to 85% relative humidity
		Non-operational	10% to 90% relative humidity
	Altitude (Operational)	3050m	
<b>Regulatory</b>	Safety: CB / cTUVus / CE		
	EMC: CE / FCC / VCCI / ICES / RCM / KC		
	RoHS: RoHS Compliant		
<p>Notes:</p> <p>a. The ConnectX-8 SuperNICs supplement the IBTA auto-negotiation specification to get better bit error rates and longer cable reaches. This supplemental feature only initiates when connected to another NVIDIA InfiniBand product.</p> <p>b. The non-operational storage temperature specifications apply to the product without its package.</p>			

## C8240 SuperNICs Specifications

<b>Physical</b>	SuperNIC Dimensions: PCIe Half Height, Half Length 2.61 in. x 6.62 in. (66.40mm x 168.40mm)		
Interfaces	See <a href="#">Supported Interfaces</a>		
	PCI Express Interface	Gen6 SERDES @ 64GT/s, x16 lanes (Gen5 compatible)	
		<b>Optional:</b> Additional PCIe x16 Gen5 @ SERDES 32GT/s through the PCIe auxiliary passive card and MCIO harness	
Networking Port: Dual-port QSFP112 InfiniBand and Ethernet			
<b>Data Rate</b>	InfiniBand	NDR/HDR/HDR100/EDR/SDR	
	Ethernet (Default)	400/200/100 Gb/s Ethernet	
<b>Protocol Support</b>	InfiniBand: IBTA v1.7 <sup>a</sup> Auto-Negotiation: NDR (4 lanes x 100Gb/s per lane) port, NDR200 (2 lanes x 100Gb/s per lane) port, HDR (50Gb/s per lane) port, HDR100 (2 lane x 50Gb/s per lane), EDR (25Gb/s per lane) port, FDR (14.0625Gb/s per lane), 1X/2X/4X SDR (2.5Gb/s per lane).		
	Ethernet: 400GAUI-4 C2M, 400GBASE-CR4, 200GAUI-2 C2M, 200GAUI-4 C2M, 200GBASE-CR4, 100GAUI-2 C2M, 100GAUI-1 C2M, 100GBASE-CR4, 100GBASE-CR2, 100GBASE-CR1, 50GAUI-2 C2M, 50GAUI-1 C2M, 50GBASE-CR, 50GBASE-R2 , 40GBASE-CR4, 40GBASE-R2, 25GBASE-R, 10GBASE-R, 10GBASE-CX4, 1000BASE-CX, CAUI-4 C2M, 25GAUI C2M, XLAUI C2M , XLPPI, SFI		
Capabilities	900-9X81Q-00CN-ST0	x16 PCIe SocketDirect/MultiHost extension option, Secure Boot Enabled, Crypto Enabled	
Electrical and Thermal Specifications	Voltage: 12V, 3.3V, 3.3VAUX		
	The complete electrical and thermal specifications are provided in " <i>NVIDIA ConnectX-8 SuperNIC Product Specifications</i> " document. You can access the document either by logging into NVOnline or by contacting your NVIDIA representative.		
<b>Environmental</b>	Temperature	Operational	0°C to 55°C
		Non-operational	-40°C to 70°C <sup>b</sup>
	Humidity	Operational	10% to 85% relative humidity

		Non-operational	10% to 90% relative humidity
	Altitude (Operational)	3050m	
<b>Regulatory</b>	Safety: CB / cTUVus / CE		
	EMC: CE / FCC / VCCI / ICES / RCM / KC		
	RoHS: RoHS Compliant		
<p>Notes:</p> <p>a. The ConnectX-8 SuperNICs supplement the IBTA auto-negotiation specification to get better bit error rates and longer cable reaches. This supplemental feature only initiates when connected to another NVIDIA InfiniBand product.</p> <p>b. The non-operational storage temperature specifications apply to the product without its package.</p>			

## Cards Mechanical Drawings and Dimensions

### **Note**

All dimensions are in millimeters. The PCB mechanical tolerance is +/- 0.13mm.

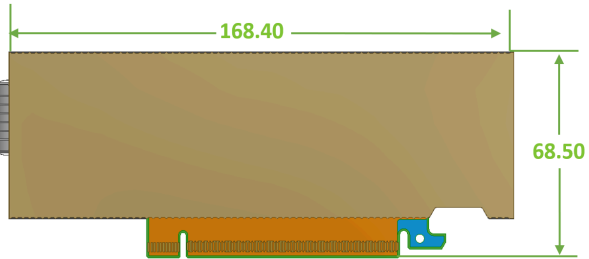
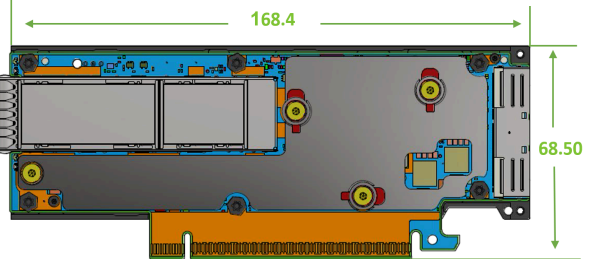
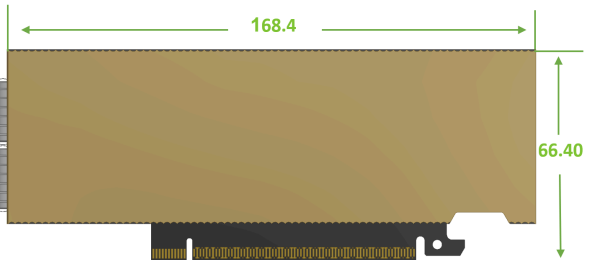
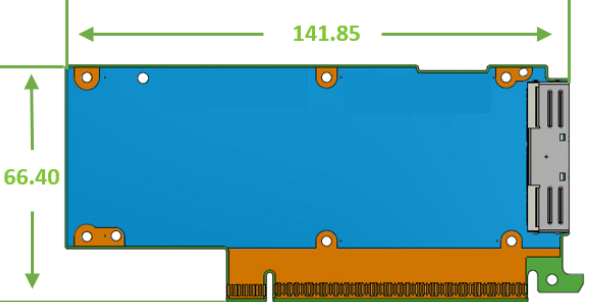
C8180 SuperNICs	C8180L SuperNICs
 <p>168.40</p> <p>68.50</p>	 <p>168.4</p> <p>68.50</p>
C8240 SuperNICs	Auxiliary PCIe Connection Card
 <p>168.4</p> <p>66.40</p>	 <p>141.85</p> <p>66.40</p>

# Brackets Mechanical Drawings and Dimensions

**Note**

All dimensions are in millimeters. The PCB mechanical tolerance is +/- 0.13mm.

OPNs	Tall Bracket	Short Bracket
C8180 SuperNICs <ul style="list-style-type: none"> <li>900-9X81E-00EX-ST0</li> <li>900-9X81E-00EX-DT0</li> </ul>		
C8240 SuperNICs 900-9X81Q-00CN-ST0		
Auxiliary PCIe Connection Card		

---

# PCIe Auxiliary Card Kit

Socket Direct or Multi-Host SuperNIC, which cost-effectively integrates a single SuperNIC and an auxiliary PCIe connection card and MCIO cable connecting the two. Socket Direct enables direct access from each CPU to the network through its dedicated PCIe interface as the card's 32-lane PCIe bus is split into two 16-lane buses, with one bus accessible through a PCIe x16 edge connector and the other bus through an x16 Auxiliary PCIe Connection card. The two cards should be installed into two PCIe x16 slots and connected using an MCIO cable.

The PCIe auxiliary kit can be purchased separately to operate in a dual-socket server. The below table lists the available PCIe auxiliary kit ordering part number.

Model	Ordering Part Number	Description
C8180X	930-9XAX6-0025-000	NVIDIA SocketDirect/MultiHost Auxiliary Kit for Additional PCIe Gen6x16 Connection, 250mm MCIO Harness

## PCIe Auxiliary Card Package Contents

Category	Qty	Item
<b>Cards</b>	1	PCIe x16 Gen5 Auxiliary Connection Card
<b>Cable</b>	1	250mm MCIO cable
<b>Accessories</b>	1	PCIe Auxiliary card short bracket
	1	PCIe Auxiliary card tall bracket (shipped assembled on the Auxiliary card)

### There are two available PCIe auxiliary kit functionalities:

1. Utilizing the Socket-Direct/Multi-Host capability, where the PCIe extension card is connected to the BlueField-3 DPU, used as an end-point.
2. Utilizing the Down Stream Port (DSP) extension option, where the PCIe extension card is connected to the BlueField-3 DPU, used as a root complex for storage devices.

## Socket Direct SuperNICs

The Socket Direct™ technology offers improved performance to dual-socket servers by enabling direct access from each CPU in a dual-socket server to the network through its dedicated PCIe interface. Utilizing the Socket-Direct or the Multi-Host capability, the PCIe extension card is connected to the SuperNIC and is used as an end-point extension.

NVIDIA offers ConnectX-8 Socket Direct, which enables 800Gb/s or 400Gb/s connectivity for servers with PCIe Gen5 or Gen4 capability, respectively. The SuperNIC's 32-lane PCIe bus is split into two 16-lane buses, with one bus accessible through a PCIe x16 edge connector and the other bus through an x16 Auxiliary PCIe Connection card. The two cards should be installed into two PCIe x16 slots and connected using an MCIO harness.

Please order the additional PCIe Auxiliary Card kit to use the SuperNIC in the Socket-Direct configuration. SuperNICs that support Socket Direct can function as separate x16 PCIe cards.

## Down Stream Port (DSP)

The ConnectX-8 SuperNIC with downstream port extension option provides connectivity to the server backplane or PCIe switch through the MCIO connector.

The default PCI interface is x4 x 4 to manage four SSD devices.

## Channel Insertion Loss

Channel insertion loss refers to the reduction in signal power due to the insertion of a device in a transmission line or optical fiber. It is typically measured in decibels (dB).

The table below outlines the channel insertion loss budget for the ConnectX-8 SuperNIC in a PCIe Gen5 architecture (32 GT/s).

The listed values are based on measured data. It is advisable to add a 0.5 dB margin to your system, as channel loss may vary.

Channel Loss at Gen5	Decibels
Total add-in card (bump to Goldfinger) Insertion loss approved by PCI-SIG Gen5	9.5 dB @16GHz
SuperNIC PCIe Lanes (PCORE1)	5 dB @16GHz

Channel Loss at Gen5	Decibels
Passive PCIe Auxiliary Card	2.5 dB @16GHz
MCIO harness (including connectors)	3.5 dB @16GHz
SuperNIC PCIe interface, PCIe Auxiliary Card, and MCIO harness	11 dB @16GHz

## MCIO Harness Pinouts

The table below lists the MCIO connector pinouts of the **MCIO harness** included in the PCIe Auxiliary Kit. For the MCIO connector pinouts on the ConnectX-8 SuperNIC, refer to [MCIO Interface](#).

Additional Electrical Information	Description/Direction	Pin	Pin	Description/Direction	Additional Electrical Information
	GND	A1	B1	GND	
	PETp0	A2	B2	PERp0	
	PETn0	A3	B3	PERn0	
	GND	A4	B4	GND	
	PETp1	A5	B5	PERp1	
	PETn1	A6	B6	PERn1	
	GND	A7	B7	GND	
<b>Logic:</b> Same power requirements as 3V3_AUX in PCIe spec <b>Voltage Level:</b> 3.3V	3V3_AUX (IN)	A8	B8	SMBUS_SCL (IN)	<b>Logic:</b> Open drain <b>Voltage:</b> 3.3V <b>Presence:</b> PU/PD: F 100k ohm
<b>Presence of PU/PD:</b> PD termination 42.2 ohm	FLEXIO0_A	A9	B9	SMBUS_SDA (BID)	<b>Logic:</b> Open drain <b>Voltage:</b> 3.3V

Additional Electrical Information	Description/Direction	Pin	Pin	Description/Direction	Additional Electrical Information
					<b>Presence:</b> PU/PD: F 100k ohm
	GND	A10	B10	GND	
<b>Logic:</b> PCIe REFCLK IN	REFCLK_A_Dp (IN)	A11	B11	PERST_A_N (IN)	<b>Logic:</b> Pull-up, active-low <b>Voltage:</b> 3.3V
<b>Logic:</b> PCIe REFCLK IN	REFCLK_A_Dn (IN)	A12	B12	CBL_PRES_A (OUT)	<b>Logic:</b> Active-low <b>Voltage:</b> 3.3V <b>Presence:</b> PU/PD: F 100k ohm <b>Recommendation:</b> Implement on System level: PU 100k ohm
	GND	A13	B13	GND	
	PETp2	A14	B14	PERp2	
	PETn2	A15	B15	PERn2	
	GND	A16	B16	GND	
	PETp3	A17	B17	PERp3	
	PETn3	A18	B18	PERn3	
	GND	A19	B19	GND	
	PETp4	A20	B20	PERp4	
	PETn4	A21	B21	PERn4	
	GND	A22	B22	GND	
	PETp5	A23	B23	PERp5	
	PETn5	A24	B24	PERn5	

Additional Electrical Information	Description/Direction	Pin	Pin	Description/Direction	Additional Electrical Information
	GND	A25	B25	GND	
<b>Presence of PU/PD:</b> PD termination 42.2 ohm	FLEXIO1_A/REFCLK_B_Dp	A26	B26	FLEXIO3_A/I2C_M_SDA_A (NC)	<b>Presence of PU/PD:</b> PD termination 42.2 ohm
<b>Presence of PU/PD:</b> PD termination 42.2 ohm	FLEXIO2_A/REFCLK_B_Dn	A27	B27	FLEXIO4_A/I2C_M_SCL_A (NC)	<b>Presence of PU/PD:</b> PD termination 42.2 ohm
	GND	A28	B28	GND	
<b>Presence of PU/PD:</b> PD termination 42.2 ohm	FLEXIO7_A	A29	B29	PERST_B_N (IN)	<b>Presence of PU/PD:</b> PD termination 42.2 ohm
<b>Presence of PU/PD:</b> PD termination 42.2 ohm	FLEXIO8_A	A30	B30	CBL_PRES_B (OUT)	<b>Presence of PU/PD:</b> PD termination 42.2 ohm
	GND	A31	B31	GND	
	PETp6	A32	B32	PERp6	
	PETn6	A33	B33	PERn6	
	GND	A34	B34	GND	
	PETp7	A35	B35	PERp7	
	PETn7	A36	B36	PERn7	
	GND	A37	B37	GND	
		<b>Key</b>			
	GND	A38	B38	GND	
	PETp8	A39	B39	PERp8	
	PETn8	A40	B40	PERn8	
	GND	A41	B41	GND	
	PETp9	A42	B42	PERp9	

<b>Additional Electrical Information</b>	<b>Description/Direction</b>	<b>Pin</b>	<b>Pin</b>	<b>Description/Direction</b>	<b>Additional Electrical Information</b>
	PETn9	A43	B43	PERn9	
	GND	A44	B44	GND	
	PETp10	A45	B45	PERp10	
	PETn10	A46	B46	PERn10	
	GND	A47	B47	GND	
	PETp11	A48	B48	PERp11	
	PETn11	A49	B49	PERn11	
	GND	A50	B50	GND	
	PETp12	A51	B51	PERp12	
	PETn12	A52	B52	PERn12	
	GND	A53	B53	GND	
	PETp13	A54	B54	PERp13	
	PETn13	A55	B55	PERn13	
	GND	A56	B56	GND	
	PETp14	A57	B57	PERp14	
	PETn14	A58	B58	PERn14	
	GND	A59	B59	GND	
	PETp15	A60	B60	PERp15	
	PETn15	A61	B61	PERn15	
	GND	A62	B62	GND	

# PCIe Auxiliary Kit Technical Specifications

## Technical Specifications

<b>Physical</b>	PCIe Auxiliary Card Size: 5.69 in. x 2.61 in. (144.75mm x 66.40mm) One MCIO cable: Length 250mm		
PCIe Connectivity	PCI Express Gen5: SERDES @ 16 GT/s, x16 lanes (Gen 3.0 compatible)		
Power Consumption	<b>Voltage:</b> 12V, 3.3V_PCIe, 3.3V_AUX		
<b>Environmental</b>	<b>Temperature</b>	<b>Operational</b>	0°C to 55°C
		<b>Non-operational</b>	-40°C to 70°C
	<b>Humidity</b>	<b>Operational</b>	10% to 85% relative humidity
		<b>Non-operational</b>	10% to 90% relative humidity
	<b>Altitude (Operational)</b>	3050m	
<b>Regulatory</b>	<b>Safety:</b> CB / cTUVus / CE		
	<b>EMC:</b> CE / FCC / VCCI / ICES / RCM / KC		
	<b>RoHS:</b> RoHS Compliant		

## PCIe Auxiliary Card Mechanical Drawings and Dimensions

### **Note**

All dimensions are in millimeters. The PCB mechanical tolerance is +/- 0.13mm.

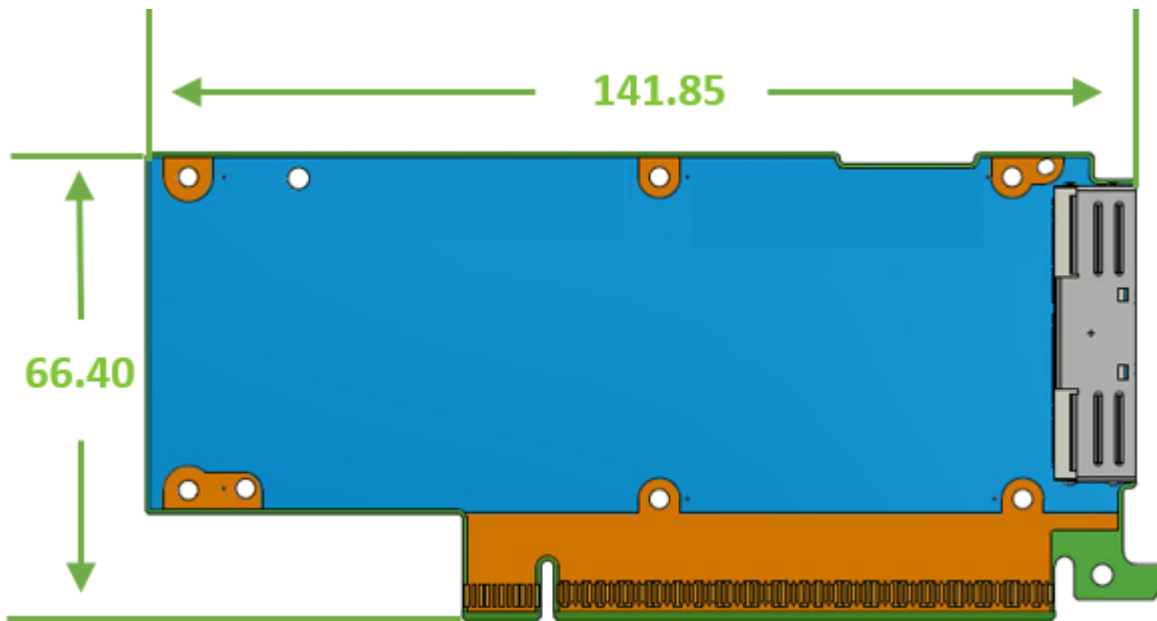

## Bracket Mechanical Drawings and Dimensions

Auxiliary PCIe Connection Card Tall Bracket	Auxiliary PCIe Connection Card Short Bracket

## MCIO Cable Mechanical Drawing

TBD

---

# General Cooling Recommendations for Partner-Cooled SuperNICs

## **Warning**

### IMPORTANT NOTES:

1. This section applies to 900-9X81E-00EX-SLO SuperNIC.
2. The customer holds exclusive responsibility for the thermal design and for ensuring all board components never exceed their designated thermal operating limits.
3. The recommendations provided in this section are based on NVIDIA reference thermal design. For further information, please refer to your NVIDIA representative.
4. If the customer's environment has low or no airflow (e.g., liquid cooling) where the SuperNIC is to be installed, the customer must ensure proper cooling for all the other board components that are not covered by the recommendations of this chapter or in the product's thermal model. The customer must guarantee those components do not exceed their thermal operating limits as well.
5. The partner-cooled thermal solution dimensions may exceed the PCIe size specifications.

## General Notes

- Recommended torque values for the bracket screws: M2: 0.21-0.23 Nm. Use tool with Torx #5 bit drive.
- Recommended torque values for the customer cooling solution interface: M2.5: 0.44~0.46 Nm.

## Components that Require Cooling

### **Warning**

It is the responsibility of the customer to ensure proper cooling and thermal regulation for all components on the board. The provided guidelines are minimal and are based on NVIDIA's reference thermal solution for partner-cooled solutions.

There are three components that require cooling, the assembled TTP (Areas A + B), the PCB (Area C) and networking port cage (Area D).

The maximum allowed force for NVIDIA's partner-cooled reference design is described below, per area. Different thermal pad placement and size may require different force values. Please contact NVIDIA support for further analysis.

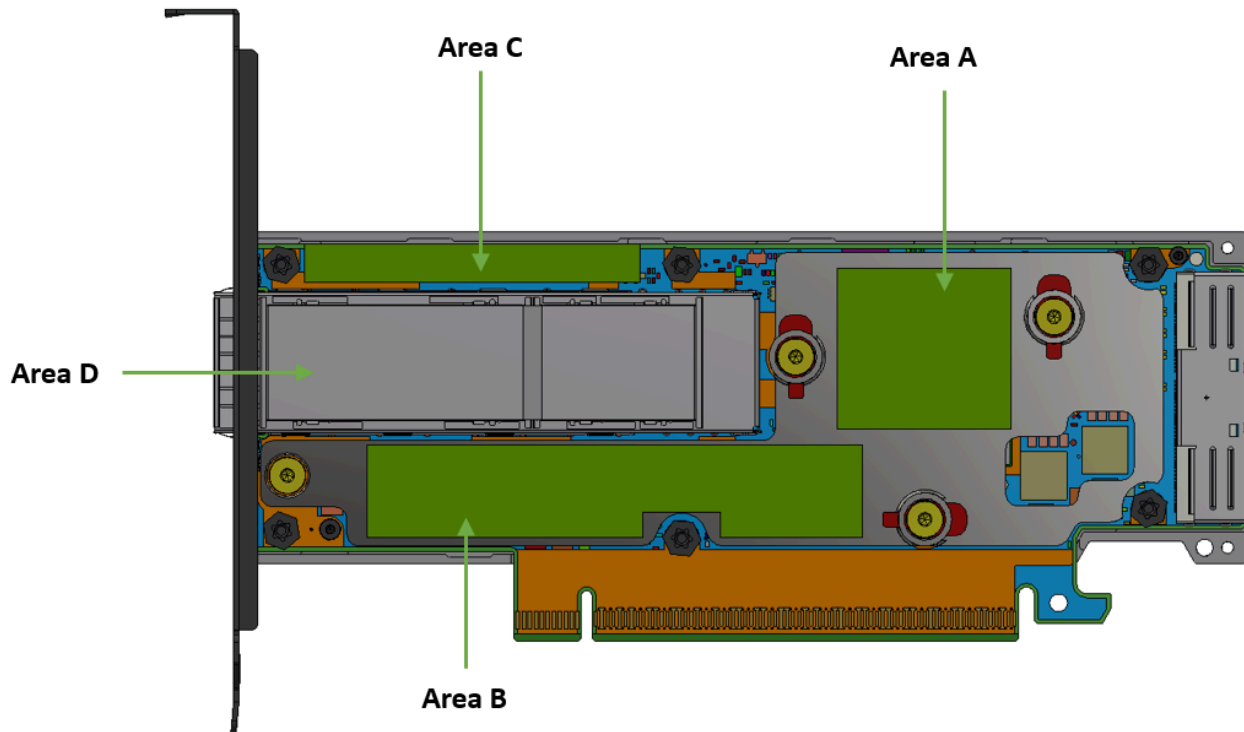

Related Component	Area in Drawing	Maximum Allowed Force
<b>TTP</b>	Area A	65 Newtons
	Area B	55 Newtons
<b>PCB</b>	Area C	25 Newtons
<b>Networking Cage</b>	Area D	The thermal grease the comes in contact with the networking cage thermal bridge. Recommended thermal grease for the cage's thermal bridge is DOWSIL TC-5622 0.1+-0.05 mm thickness. The customer partner-solution should protrude the OSFP thermal bridge by 0.2mm nominal.

- Thermal Pad minimum allowable conductivity is 2.5 W/mK.

## Suggested Server Connectivity Interfaces

**Note**

Six standoffs are provided on the card; their use is optional.

According to the customer design, the screws should be assembled from the customer cooling solution, through the standoffs on the ConnectX-8 SuperNIC (6 standoffs are available on the card, the use of these standoffs is optional).

The standoffs type is M2x0.4 thread and the maximum thread depth 2.0 mm.

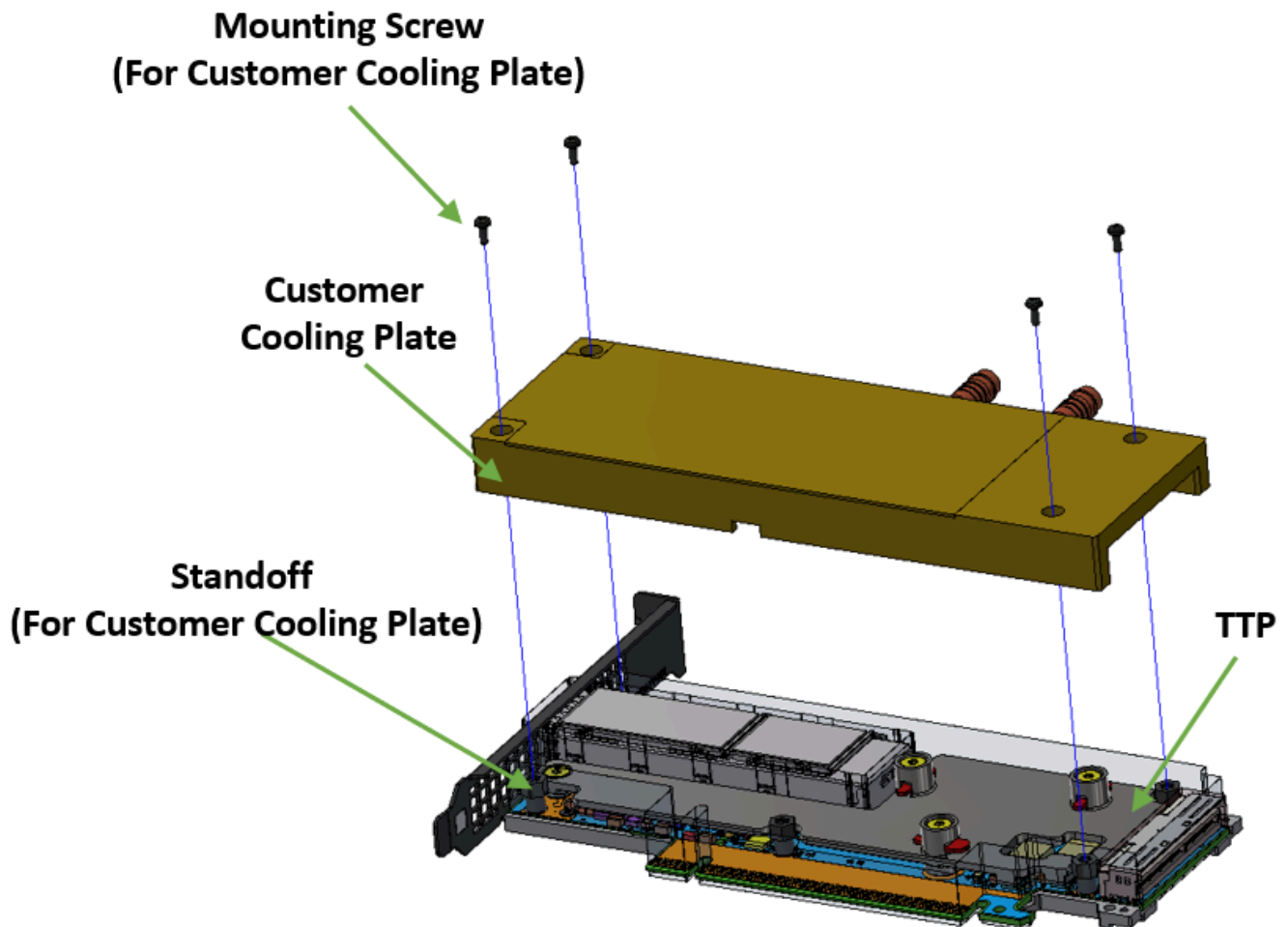

## Threads and Holes

To ensure proper SuperNIC connectivity to the server and TTP, the below figure displays the SuperNIC threads and holes and provides its size and tolerance.

# Bracket Replacement

## Bracket Replacement Instructions

The ConnectX-8 Partner-Cooled SuperNIC and PCIe Auxiliary card are shipped with an assembled high-profile bracket. If this form factor is suitable for your requirements, you can skip the remainder of this section and move to [Installation Instructions](#). If you need to replace the high-profile bracket with the short bracket that is included in the shipping box, please follow the instructions in this section.

### **Warning**

During the bracket replacement procedure, do not pull, bend, or damage the EMI fingers cage. It is recommended to limit bracket replacements to three times.

To replace the bracket you will need the following parts:

- The new brackets of the proper height
- The 2 screws and 2 standoffs saved from the removal of the bracket
- A customized jig. The jig design will be provided in a future version of this document.

### **Removing the Existing Bracket**

1. Using a torque driver, remove the two screws and two standoffs holding the bracket in place.
2. Separate the bracket from the ConnectX-8 SuperNIC.

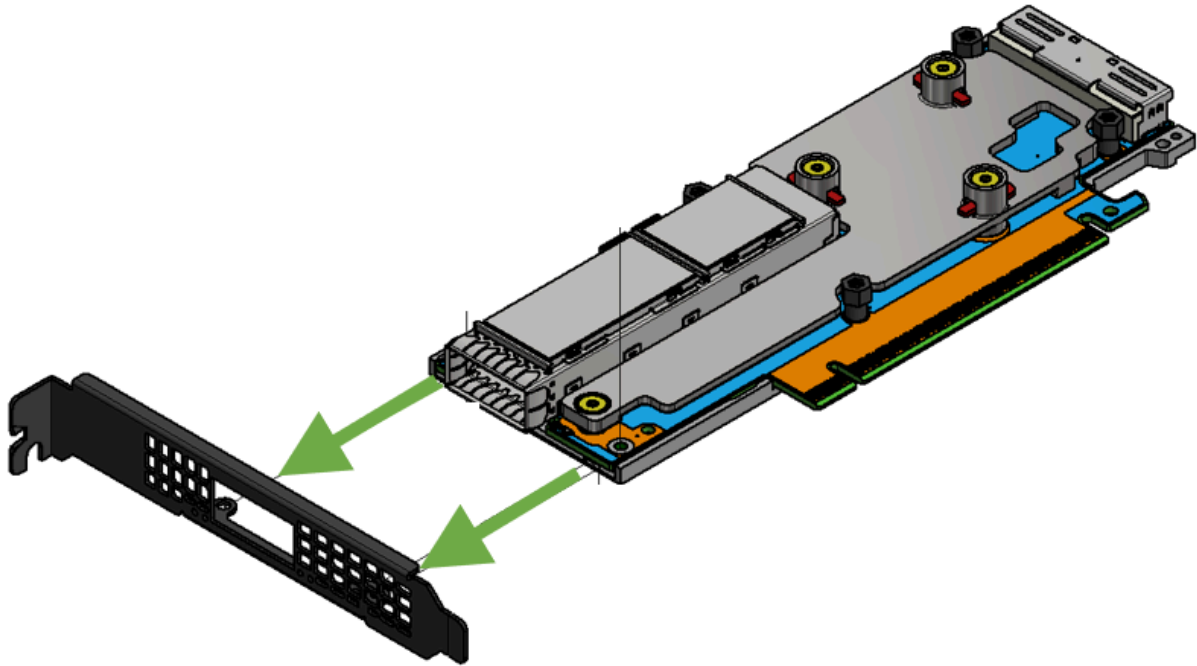

**⚠ Warning**

Be careful not to put stress on the LEDs on the SuperNIC.

3. Save the three screws and two standoffs, as shown below.

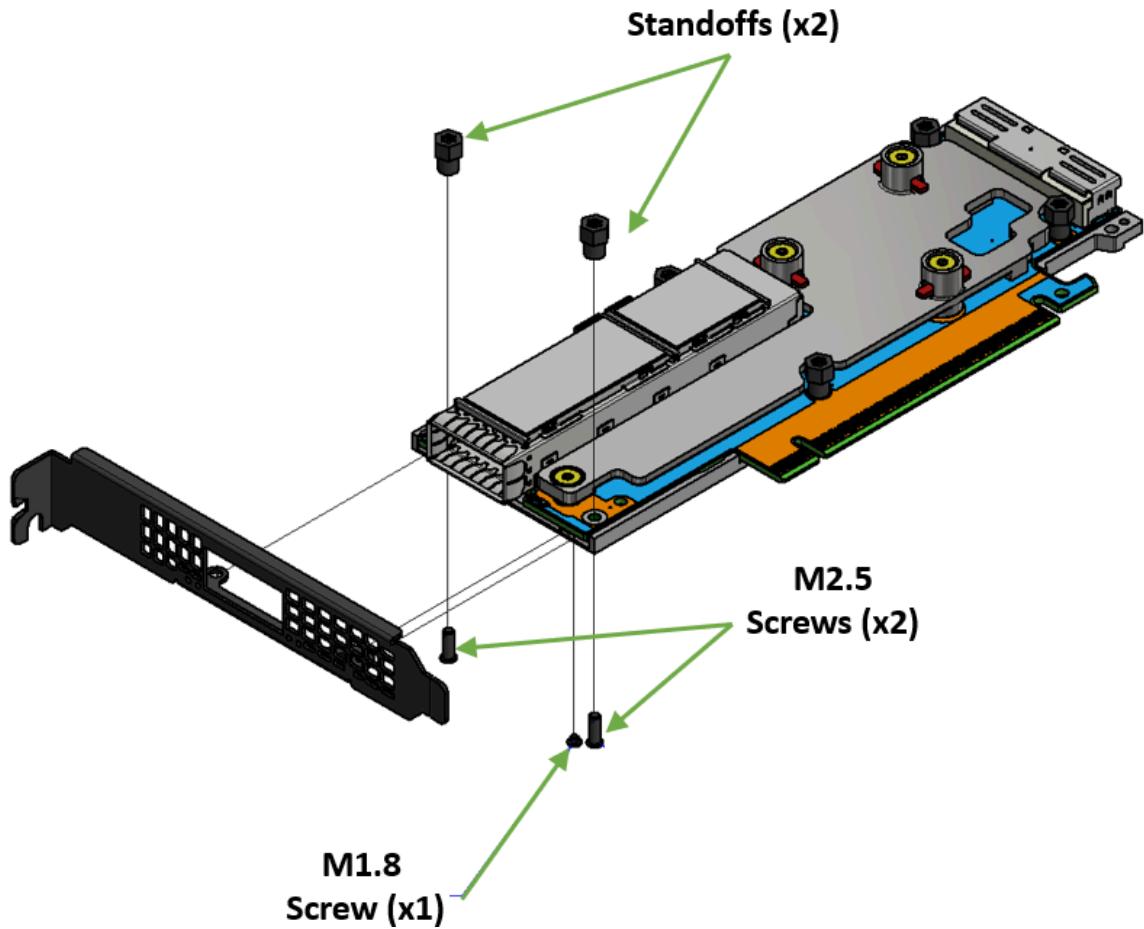

## Installing the New Bracket

1. Place the bracket onto the SuperNIC until the screw holes line up.

### **Warning**

Do not force the bracket onto the SuperNIC.

2. Screw on the bracket using the screws and standoffs saved from the bracket removal procedure above.

Use a torque driver to apply up torque on the screws and standoffs as described in the below.[images/download/attachments/3904725876/image-2025-5-13\\_14-51-14-version-1-modificationdate-1747650802390-api-v2.png](https://images/download/attachments/3904725876/image-2025-5-13_14-51-14-version-1-modificationdate-1747650802390-api-v2.png)

---

# Document Revision History

Date	Comments/Changes
July. 2023	<ul style="list-style-type: none"><li>• Updated OPNs' marketing description</li><li>• Added a note to <a href="#">General Cooling Recommendations for Partner-Cooled SuperNICs</a> about the optional use of the card's standoffs</li></ul>
May. 2025	<ul style="list-style-type: none"><li>• Added 900-9X81E-00EX-SL0 SuperNIC support across the document</li><li>• Added <a href="#">General Cooling Recommendations for Partner-Cooled SuperNICs</a></li><li>• Fixed a typo in <a href="#">Specifications</a></li><li>• Updated the InfiniBand supported protocols in <a href="#">Introduction</a></li></ul>
Mar. 2025	Updated: <ul style="list-style-type: none"><li>• <a href="#">Finding the GUID/MAC on the SuperNIC</a></li><li>• <a href="#">Port Splitting Configurations</a></li></ul>
Feb. 2025	Updated: <ul style="list-style-type: none"><li>• <a href="#">PCIe Bifurcation Configuration Options</a></li><li>• <a href="#">Driver Installation</a></li><li>• <a href="#">Specifications</a></li><li>• <a href="#">PCIe Auxiliary Card Kit</a></li></ul>
Jan. 2025	Updated <a href="#">Hardware Installation</a>
Dec. 2024	Added <a href="#">Port Splitting Configurations</a>
Aug. 2024	First release

## Notice

This document is provided for information purposes only and shall not be regarded as a warranty of a certain functionality, condition, or quality of a product. NVIDIA Corporation ("NVIDIA") makes no representations or warranties, expressed or implied, as to the accuracy or completeness of the information contained in this document and assumes no responsibility for any errors contained herein. NVIDIA shall have no liability for the consequences or use of such information or for any infringement of patents or other rights of third parties that may result from its use. This document is not a commitment to develop, release, or deliver any Material (defined below), code, or functionality.

NVIDIA reserves the right to make corrections, modifications, enhancements, improvements, and any other changes to this document, at any time without notice.

Customer should obtain the latest relevant information before placing orders and should verify that such information is current and complete.

NVIDIA products are sold subject to the NVIDIA standard terms and conditions of sale supplied at the time of order acknowledgement, unless otherwise agreed in an individual sales agreement signed by authorized representatives of NVIDIA and customer ("Terms of Sale"). NVIDIA hereby expressly objects to applying any customer general terms and conditions with regards to the purchase of the NVIDIA product referenced in this document. No contractual obligations are formed either directly or indirectly by this document.

NVIDIA products are not designed, authorized, or warranted to be suitable for use in medical, military, aircraft, space, or life support equipment, nor in applications where failure or malfunction of the NVIDIA product can reasonably be expected to result in personal injury, death, or property or environmental damage. NVIDIA accepts no liability for inclusion and/or use of NVIDIA products in such equipment or applications and therefore such inclusion and/or use is at customer's own risk.

NVIDIA makes no representation or warranty that products based on this document will be suitable for any specified use. Testing of all parameters of each product is not necessarily performed by NVIDIA. It is customer's sole responsibility to evaluate and determine the applicability of any information contained in this document, ensure the product is suitable and fit for the application planned by customer, and perform the necessary testing for the application in order to avoid a default of the application or the product. Weaknesses in customer's product designs may affect the quality and reliability of the NVIDIA product and may result in additional or different conditions and/or requirements beyond those contained in this document. NVIDIA accepts no liability related to any default, damage, costs, or problem which may be based on or attributable to: (i) the use of the NVIDIA product in any manner that is contrary to this document or (ii) customer product designs.

No license, either expressed or implied, is granted under any NVIDIA patent right, copyright, or other NVIDIA intellectual property right under this document. Information published by NVIDIA regarding third-party products or services does not constitute a license from NVIDIA to use such products or services or a warranty or endorsement thereof. Use of such information may require a license from a third party under the patents or other intellectual property rights of the third party, or a license from NVIDIA under the patents or other intellectual property rights of NVIDIA.

Reproduction of information in this document is permissible only if approved in advance by NVIDIA in writing, reproduced without alteration and in full compliance with all applicable export laws and regulations, and accompanied by all associated conditions, limitations, and notices.

THIS DOCUMENT AND ALL NVIDIA DESIGN SPECIFICATIONS, REFERENCE BOARDS, FILES, DRAWINGS, DIAGNOSTICS, LISTS, AND OTHER DOCUMENTS (TOGETHER AND SEPARATELY, "MATERIALS") ARE BEING PROVIDED "AS IS." NVIDIA MAKES NO WARRANTIES, EXPRESSED, IMPLIED, STATUTORY, OR OTHERWISE WITH RESPECT TO THE MATERIALS, AND EXPRESSLY DISCLAIMS ALL IMPLIED WARRANTIES OF NONINFRINGEMENT, MERCHANTABILITY, AND FITNESS FOR A PARTICULAR PURPOSE. TO THE EXTENT NOT PROHIBITED BY LAW, IN NO EVENT WILL NVIDIA BE LIABLE FOR ANY DAMAGES, INCLUDING WITHOUT LIMITATION ANY DIRECT, INDIRECT, SPECIAL, INCIDENTAL, PUNITIVE, OR CONSEQUENTIAL DAMAGES, HOWEVER CAUSED AND REGARDLESS OF THE THEORY OF LIABILITY, ARISING OUT OF ANY USE OF THIS DOCUMENT, EVEN IF NVIDIA HAS BEEN ADVISED OF THE POSSIBILITY OF SUCH DAMAGES. Notwithstanding any damages that customer might incur for any reason whatsoever, NVIDIA's aggregate and cumulative liability towards customer for the products described herein shall be limited in accordance with the Terms of Sale for the product.

## **Trademarks**

NVIDIA and the NVIDIA logo are trademarks and/or registered trademarks of NVIDIA Corporation in the U.S. and other countries. Other company and product names may be trademarks of the respective companies with which they are associated.

© Copyright 2025, NVIDIA. PDF Generated on 07/14/2025