

E23321

Revised Edition V2 / April 2024

IN SEARCH OF INCREDIBLE



Service Manual

ASUS

COPYRIGHT INFORMATION

No part of this manual, including the products and software described in it, may be reproduced, transmitted, transcribed, stored in a retrieval system, or translated into any language in any form or by any means, except documentation kept by the purchaser for backup purposes, without the express written permission of ASUSTeK COMPUTER INC. ("ASUS").

ASUS PROVIDES THIS MANUAL "AS IS" WITHOUT WARRANTY OF ANY KIND, EITHER EXPRESS OR IMPLIED, INCLUDING BUT NOT LIMITED TO THE IMPLIED WARRANTIES OR CONDITIONS OF MERCHANTABILITY OR FITNESS FOR A PARTICULAR PURPOSE. IN NO EVENT SHALL ASUS, ITS DIRECTORS, OFFICERS, EMPLOYEES OR AGENTS BE LIABLE FOR ANY INDIRECT, SPECIAL, INCIDENTAL, OR CONSEQUENTIAL DAMAGES (INCLUDING DAMAGES FOR LOSS OF PROFITS, LOSS OF BUSINESS, LOSS OF USE OR DATA, INTERRUPTION OF BUSINESS AND THE LIKE), EVEN IF ASUS HAS BEEN ADVISED OF THE POSSIBILITY OF SUCH DAMAGES ARISING FROM ANY DEFECT OR ERROR IN THIS MANUAL OR PRODUCT.

Products and corporate names appearing in this manual may or may not be registered trademarks or copyrights of their respective companies, and are used only for identification or explanation and to the owners' benefit, without intent to infringe.

SPECIFICATIONS AND INFORMATION CONTAINED IN THIS MANUAL ARE FURNISHED FOR INFORMATIONAL USE ONLY, AND ARE SUBJECT TO CHANGE AT ANY TIME WITHOUT NOTICE, AND SHOULD NOT BE CONSTRUED AS A COMMITMENT BY ASUS. ASUS ASSUMES NO RESPONSIBILITY OR LIABILITY FOR ANY ERRORS OR INACCURACIES THAT MAY APPEAR IN THIS MANUAL, INCLUDING THE PRODUCTS AND SOFTWARE DESCRIBED IN IT.

Copyright © 2024 ASUSTeK COMPUTER INC. All Rights Reserved.

LIMITATION OF LIABILITY

Circumstances may arise where because of a default on ASUS' part or other liability, you are entitled to recover damages from ASUS. In each such instance, regardless of the basis on which you are entitled to claim damages from ASUS, ASUS is liable for no more than damages for bodily injury (including death) and damage to real property and tangible personal property; or any other actual and direct damages resulted from omission or failure of performing legal duties under this Warranty Statement, up to the listed contract price of each product.

ASUS will only be responsible for or indemnify you for loss, damages or claims based in contract, tort or infringement under this Warranty Statement.

This limit also applies to ASUS' suppliers and its reseller. It is the maximum for which ASUS, its suppliers, and your reseller are collectively responsible.

UNDER NO CIRCUMSTANCES IS ASUS LIABLE FOR ANY OF THE FOLLOWING: (1) THIRD-PARTY CLAIMS AGAINST YOU FOR DAMAGES; (2) LOSS OF, OR DAMAGE TO, YOUR RECORDS OR DATA; OR (3) SPECIAL, INCIDENTAL, OR INDIRECT DAMAGES OR FOR ANY ECONOMIC CONSEQUENTIAL DAMAGES (INCLUDING LOST PROFITS OR SAVINGS), EVEN IF ASUS, ITS SUPPLIERS OR YOUR RESELLER IS INFORMED OF THEIR POSSIBILITY.

SERVICE AND SUPPORT

Visit our multi-language website at <https://www.asus.com/support/>.

Table of Contents

Chapter 1: Introduction

Disclaimer	8
Safety precautions.....	8
Pre-repair checklist	10
Installation tools.....	11
Accessories.....	11
Diagnostic tools	11
Major components.....	12

Chapter 2: Service Procedures

Bottom cover	16
Removal	17
Installation	20
Battery	23
Removal	24
Installation	28
M.2 SSD module.....	32
Removal	33
Installation	35
RAM module.....	37
Removal	38
Installation	39
WLAN module.....	40
Removal	41
Installation	42

Speakers.....	43
Removal	44
Installation	46
Fan module, heat sink and motherboard	48
Removal	50
Installation	60
I/O board.....	70
Removal	71
Installation	75
Touchpad.....	79
Removal	80
Installation	86
Display panel module	92
Removal	93
Installation	99
Display bezel	104
Removal	105
Installation	108
Display hinges.....	111
Removal	112
Installation	114
Display panel.....	116
Removal	117
Installation	119
Camera module.....	122
Removal	123
Installation	124

Top cover	125
Removal	126
Installation	127
Keyboard module	128
Removal	129
Installation	131

Appendices

Wiring and connection diagrams	134
--------------------------------------	-----

Chapter 1: ***Introduction***

Disclaimer

ASUS is not responsible for direct, indirect, intentional or unintentional damages resulting from improper installation and operation.

Safety precautions

- Before handling components, use a grounded wrist strap or touch a safely grounded object to avoid damaging them due to static electricity.
- Keep liquids or moisture away from your device to avoid short circuits.
- Remove rings, watches, and any other metal objects from your hands.
- Hold components by the edges to avoid touching the ICs.
- Properly install all components before connecting the AC power.
- Do not use power adapters or batteries from other devices to reduce the risk of injury to persons due to fire or explosion. Use only certified power adapters or batteries supplied by the manufacturer or authorized retailers.
- Detach all clips or flaps before removing cables to prevent damage.

- Disconnect cables, connectors, and power plugs by pulling the plug evenly to avoid damage.
- Use the correct screw models on your device to prevent damage.
- Confirm that the cable orientation is correct before connecting any cables.
- Fully remove all adhesive residue after removing and before installing any components.
- Photograph the appearance of cables, cable routing, connectors, and screws for later reference before proceeding with each step.

Pre-repair checklist

- Read the entire manual before starting any service procedures and follow all instructions.
 - Back up the data on your device.
 - Place your device on a clean and stable surface.
 - Turn off your device.
 - Disconnect all connected peripherals and cables.
 - Disconnect all power cables and remove the battery pack (if applicable).
-

IMPORTANT!

- If you are uncertain about performing the described service procedures, stop and contact an authorized service center for assistance.
 - Purchase replacement components from authorized retailers of this device to ensure maximum compatibility and reliability.
-

NOTE:

- The illustrations are for reference only.
 - The service procedures described in this manual depend on the model configuration and may not reflect the entire servicing process. To service components that are not covered in this manual, please visit an authorized service center for further assistance.
 - Keep all adhesive tape, insulating materials, screws, and other removable items in a safe place until the service procedure is completed, as they may be needed during installation.
-

Installation tools



Screwdriver



Plastic blade



Tweezers

Accessories



Power adapter

Diagnostic tools

Use ASUS System Diagnostics after completing any service procedures to ensure that all components are working properly.

For more information, visit www.asus.com/support/FAQ/1048490/.

Major components



Top cover

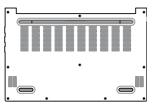

Bottom cover



Display bezel



Display panel



Keyboard module

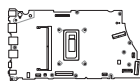

Motherboard



I/O board

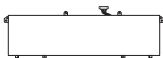

Battery



Camera module

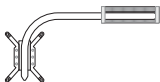

Heat sink



Fan



Touchpad

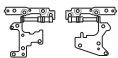

Display hinges



Speakers

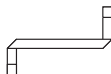

FFC cables



Antenna cables



eDP cable



RAM module

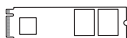

M.2 SSD module



WLAN module



Hinge cap

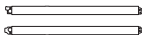

Display brackets



Battery power cable*

** On selected models*

Chapter 2: ***Service Procedures***

Bottom cover

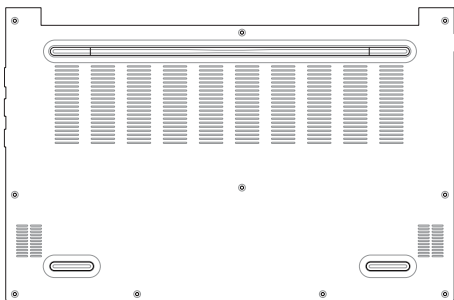

Before you begin

Read the **Safety Precautions** and complete the **Pre-repair Checklist**.

Screw list

14" model

- ⊕ M2.0 X 8.0L (1pc)
- ⊕ M2.0 X 6.0L (5pcs)
- ⊕ M2.0 X 3.5L (4pcs)

15" model

- ⊕ M2.0 X 8.0L (2pcs)
- ⊕ M2.0 X 6.5L (4pcs)
- ⊕ M2.0 X 3.5L (4pcs)

17" model

● ⊕ M2.0 X 7.0L (7pcs)

● ⊕ M2.0 X 3.5L (4pcs)

Removal

1. Remove the screw(s) from the bottom cover.

14" model

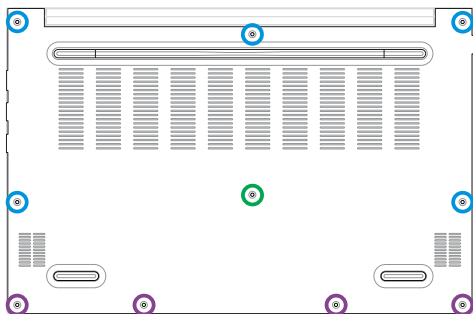

15" model

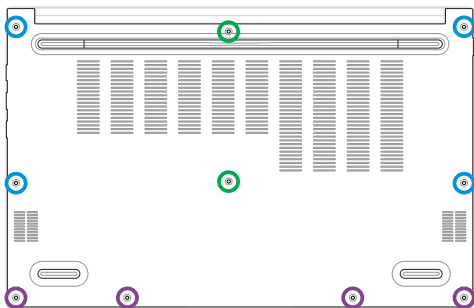

17" model

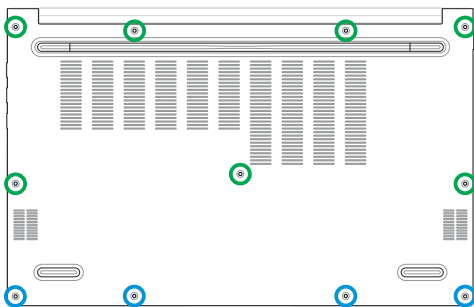

2. Use the plastic blade to pry open the indicated area of the bottom cover as shown in the illustration below.

IMPORTANT! Avoid sliding the plastic blade along the side of your device or air vents to prevent damage.

3. Remove the bottom cover.

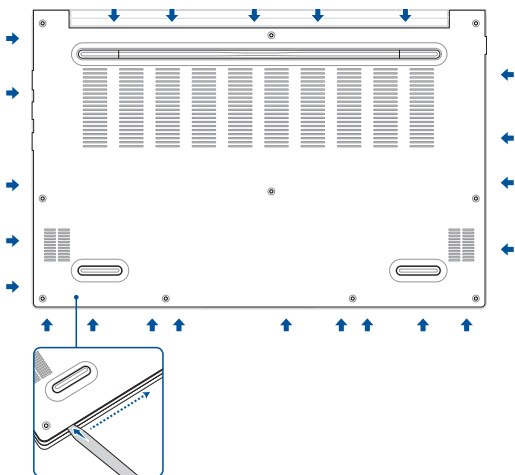

Installation

1. Install the bottom cover.
2. Gently press down on the bottom cover until it clicks into place.

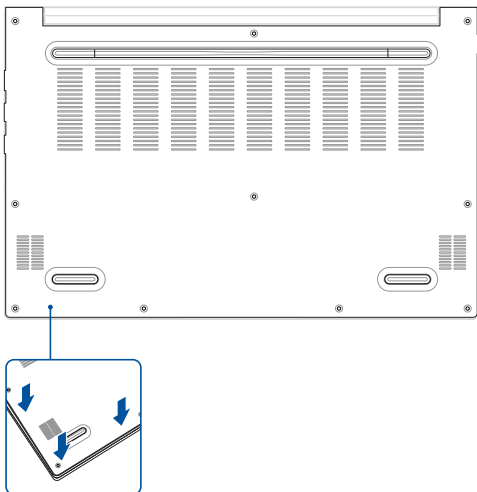

3. Secure the bottom cover using the screw(s) you removed earlier.

14" model

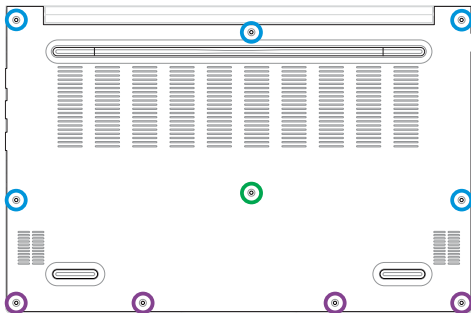

15" model

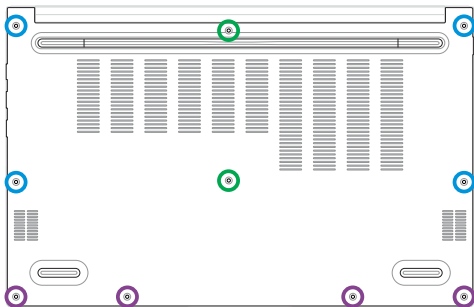

17" model

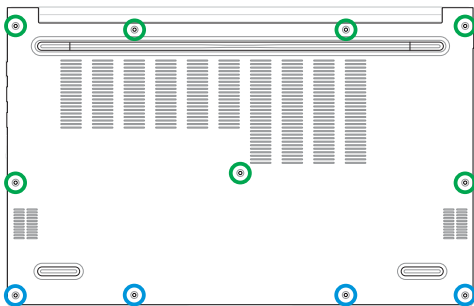

Battery

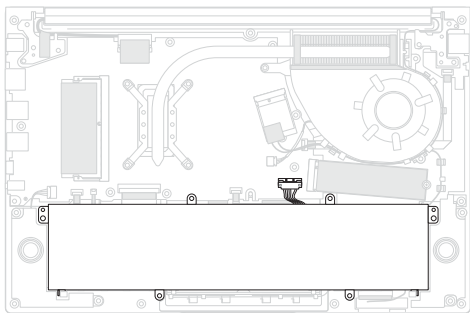

Before you begin

1. Read the **Safety Precautions** and **Pre-repair Checklist**.
2. Remove the following components:
 - Bottom cover

Screw list

14" model

- ⊕ M2.0 X 4.5L (3pcs)

15"/17" model

- ⊕ M2.0 X 3.5L (4pcs)

Removal

1. Disconnect the battery power cable.

IMPORTANT!

- Disconnect the battery power cable by lifting the side with the red wires first.
 - Serious risk of fire or explosion may occur if the battery is punctured. If you are uncertain about proceeding, stop and contact an authorized service center for assistance.
-

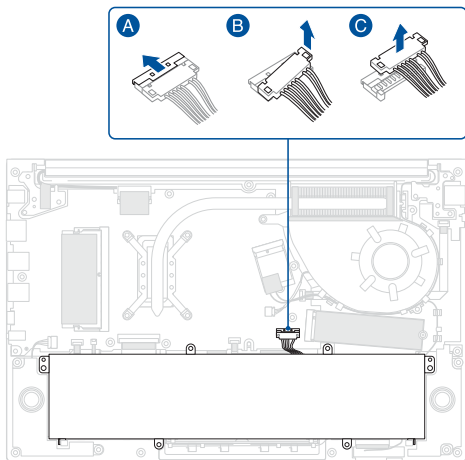

2. Remove the screw(s) from the battery.
3. Remove the battery.

14" model

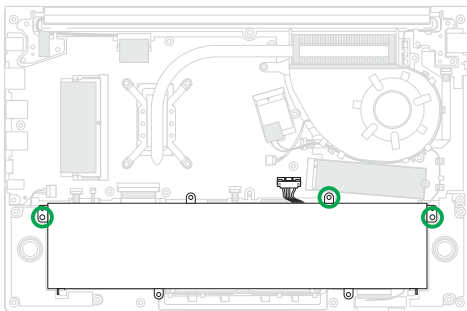

15" model

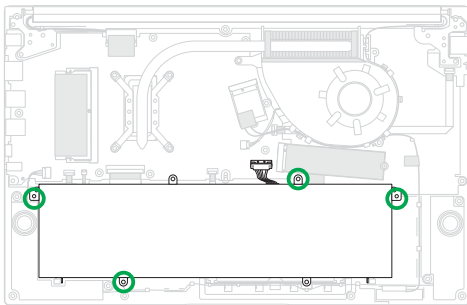

17" model

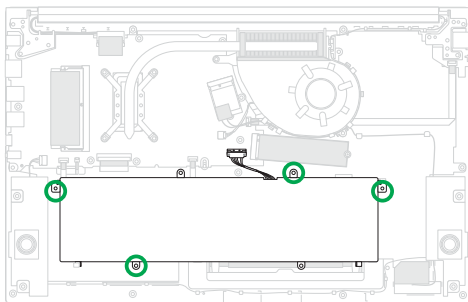

4. (On 15" model) Remove the battery power cable.

NOTE: This step is only required when you are replacing the existing component with a new one.

15" model

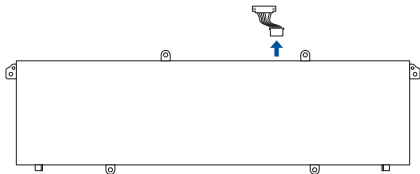

Installation

1. (On 15" model) Connect the battery power cable to the battery.

NOTE: This step is only required when you are replacing the existing component with a new one.

15" model

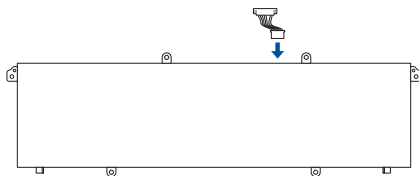

2. Install the battery.
3. Secure the battery using the screw(s) you removed earlier.

14" model

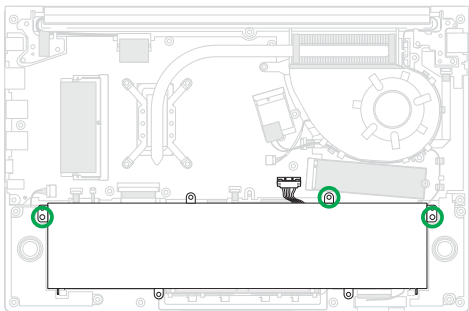

15" model

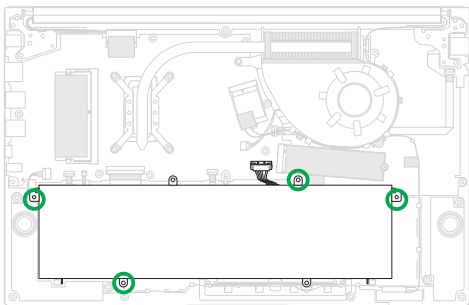

17" model

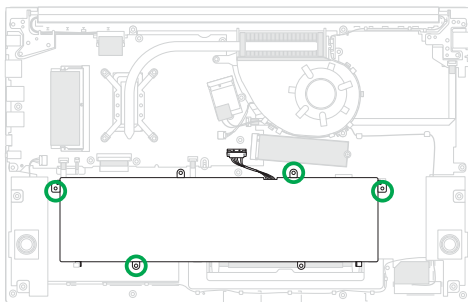

4. Reconnect the battery power cable.
5. Install the components you removed in the *Before you begin* section.

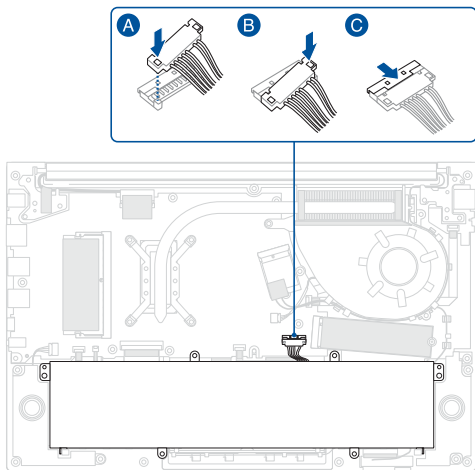

M.2 SSD module

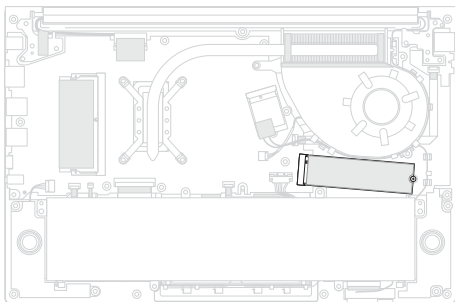

Before you begin

1. Read the **Safety Precautions** and **Pre-repair Checklist**.
2. Remove the following components:
 - Bottom cover
 - Battery

Screw list

14"/15" model

- ⊕ M2.0 X 2.0L (1pc)

17" model

- ⊕ M2.0 X 3.0L (1pc)

Removal

1. Remove the screw, then remove the M.2 SSD module from the motherboard.

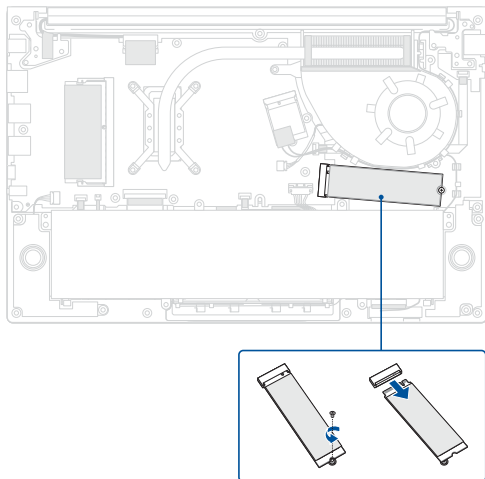

2. Remove the polyester film.

NOTE: This step is only required when you are replacing the existing component with a new one.

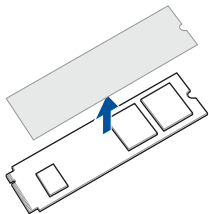

Installation

1. Reattach the polyester film.

NOTE: This step is only required when you are replacing the existing component with a new one.

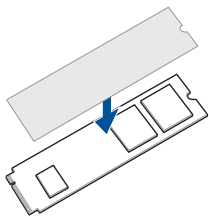

2. Align and insert the M.2 SSD module into the M.2 connector on the motherboard, then secure the M.2 SSD module using the screw you removed earlier.
3. Install the components you removed in the *Before you begin* section.

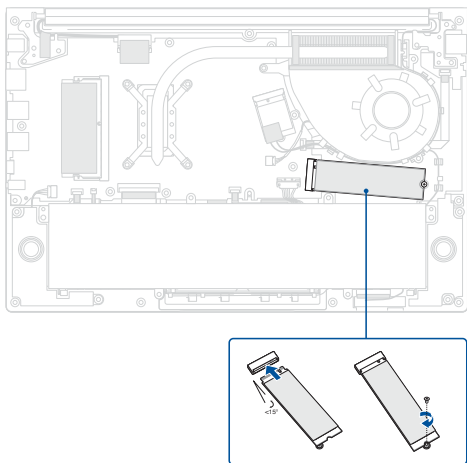

RAM module

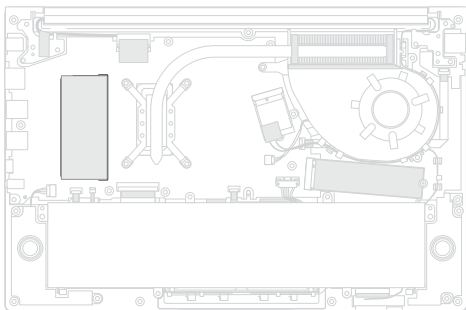

Before you begin

1. Read the **Safety Precautions** and **Pre-repair Checklist**.
2. Remove the following components:
 - Bottom cover
 - Battery

Removal

1. Remove the polyester film from the RAM module.
2. Push the clips outwards to remove the RAM module.

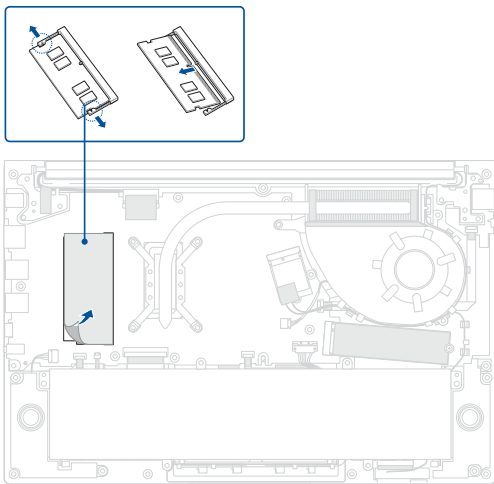

Installation

1. Align and insert the RAM module into the RAM module slot.
2. Reattach the polyester film.
3. Install the components you removed in the *Before you begin* section.

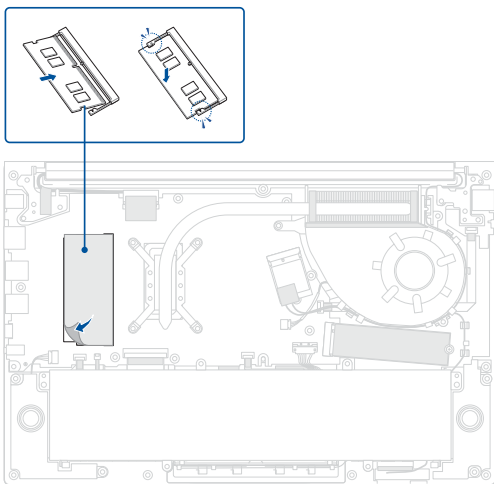

WLAN module

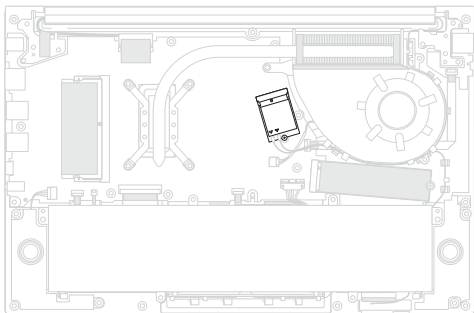

Before you begin

1. Read the **Safety Precautions** and **Pre-repair Checklist**.
2. Remove the following components:
 - Bottom cover
 - Battery

Screw list

14"/15" model

- ⊕ M2.0 X 2.0L (1pc)

17" model

- ⊕ M2.0 X 3.0L (1pc)

Removal

Disconnect the antenna cable(s), then remove the screw and remove the WLAN module.

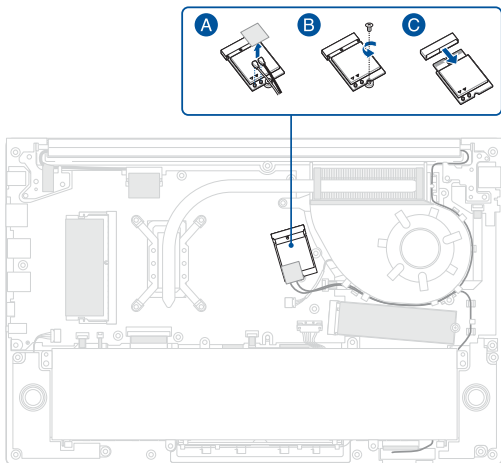

Installation

1. Install the WLAN module, then secure the WLAN module using the screw you removed earlier and reconnect the antenna cable(s).
2. Install the components you removed in the *Before you begin* section.

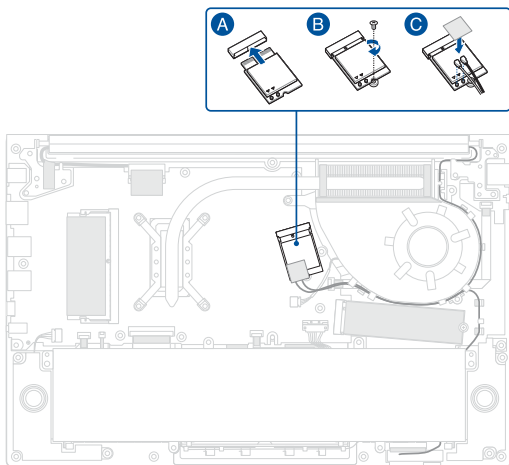

Speakers

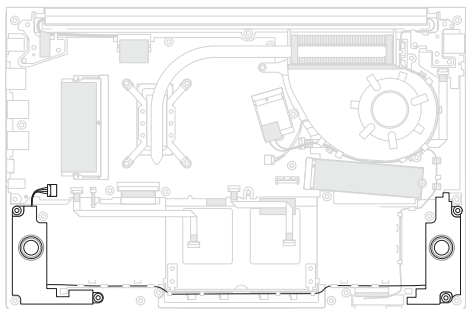

Before you begin

1. Read the **Safety Precautions** and **Pre-repair Checklist**.
2. Remove the following components:
 - Bottom cover
 - Battery

Removal

1. Disconnect the speaker connector.
2. Remove the speaker cable from the cable guide(s).
3. Remove the speakers.

14" model

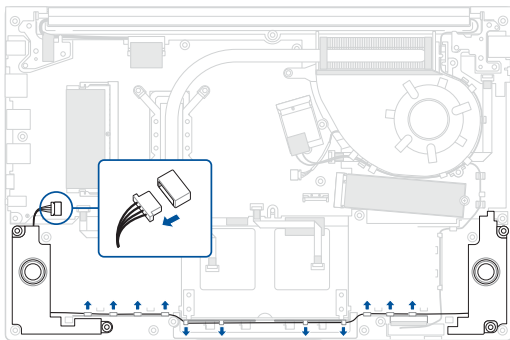

15" model

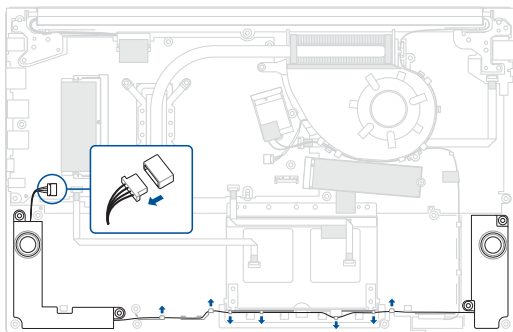

17" model

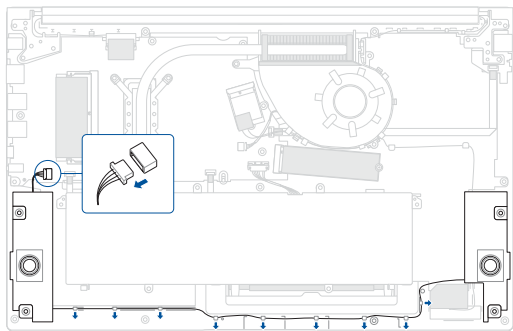

Installation

1. Install the speakers.
2. Route the speaker cable through the cable guide(s).

IMPORTANT! Damage may occur if cables are not properly routed through the cable guides. Confirm that all cables are routed through each of the indicated cable guides before proceeding.

3. Reconnect the speaker connector.
4. Install the components you removed in the *Before you begin* section.

14" model

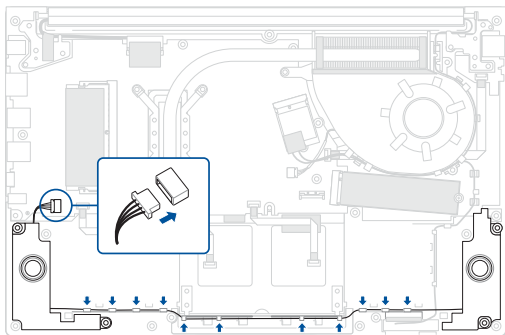

15" model

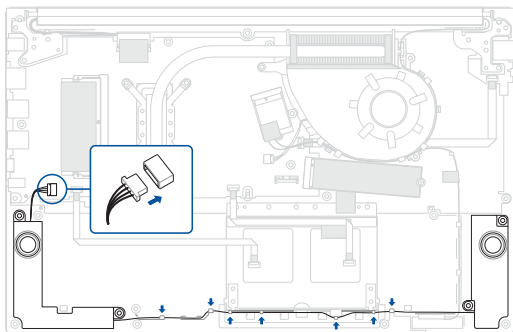

17" model

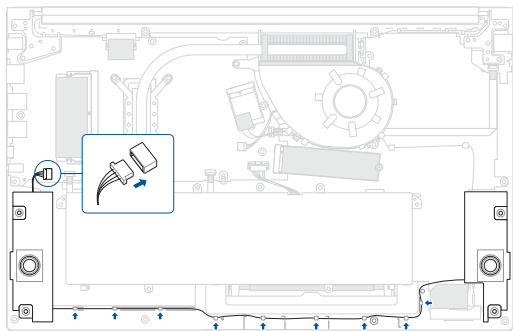

Fan module, heat sink and motherboard

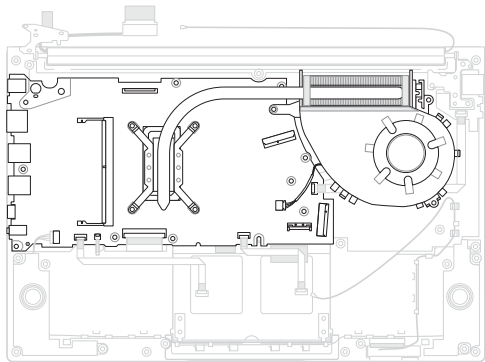

Before you begin

IMPORTANT! Thermal paste, thermal pads, liquid metal, or other thermal interface materials must be thoroughly removed and replaced if this component is removed. Ensure that replacement materials are available before proceeding, or contact an authorized service center for assistance.

1. Read the **Safety Precautions** and **Pre-repair Checklist**.

2. Remove the following components:

- Bottom cover
- Battery
- M.2 SSD module
- RAM module
- WLAN module

Screw list

14" model

- ⊕ M2.5 X 4.5L (2pcs)
- ⊕ M2.5 X 3.0L (2pcs)
- ⊕ M2.0 X 3.0L (5pcs)
- ⊕ M2.0 X 2.0L (6pcs)

15" model

- ⊕ M2.5 X 4.5L (2pcs)
- ⊕ M2.5 X 3.5L (2pcs)
- ⊕ M2.0 X 3.0L (4pcs)
- ⊕ M2.0 X 2.0L (7pcs)

17" model

- ⊕ M2.5 X 5.0L (2pcs)
- ⊕ M2.0 X 3.5L (2pcs)
- ⊕ M2.0 X 3.0L (3pcs)
- ⊕ M2.0 X 2.5L (1pc)
- ⊕ M2.0 X 2.0L (4pcs)

Removal

1. Disconnect the cable(s) and remove the cable(s) from the cable guide(s).

14" model

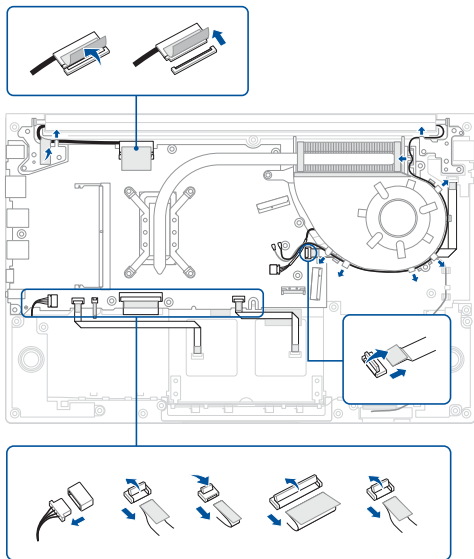

15" model

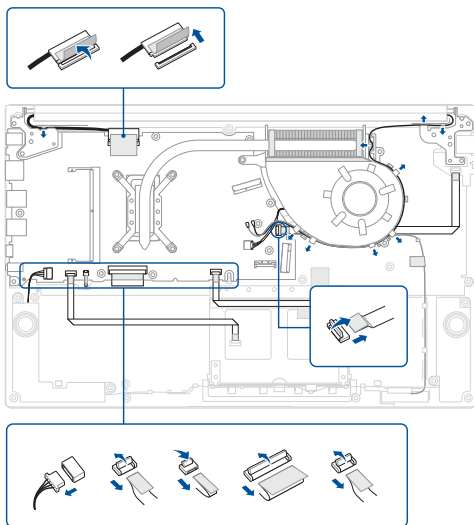

17" model

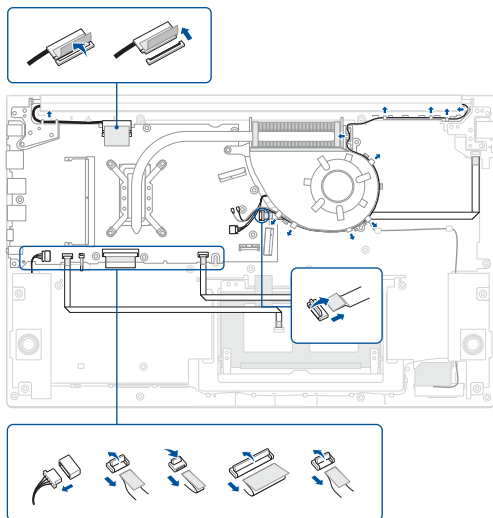

2. Remove the screw(s) from the hinge on the left side, then lift the hinge to a 90-degree position.

14" model

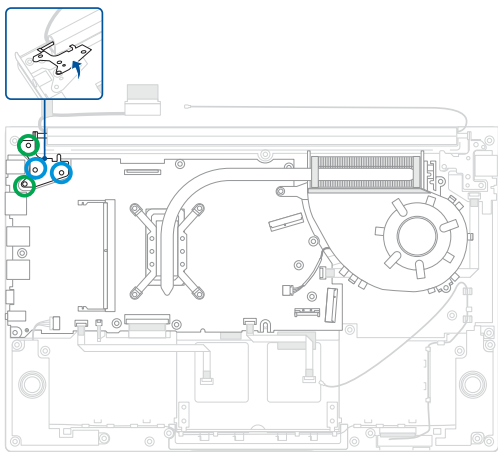

15" model

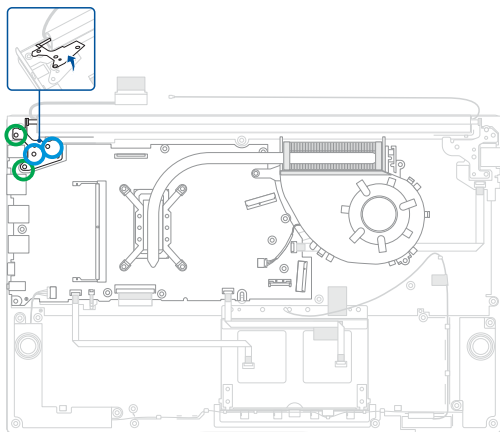

17" model

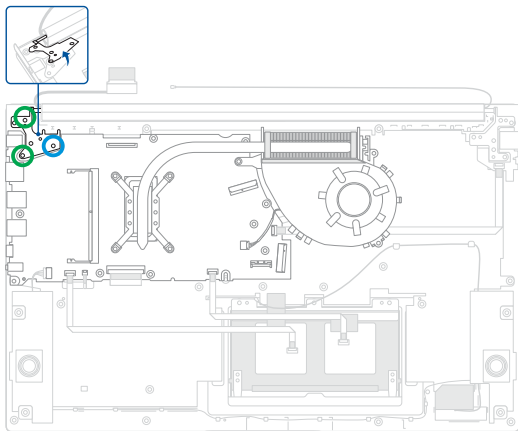

3. Remove the screw(s), then remove the motherboard with the heat sink and fan attached.

14" model

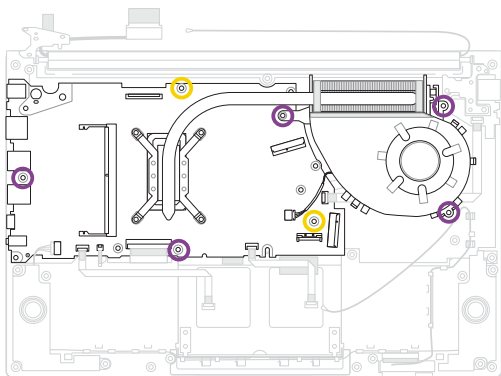

15" model

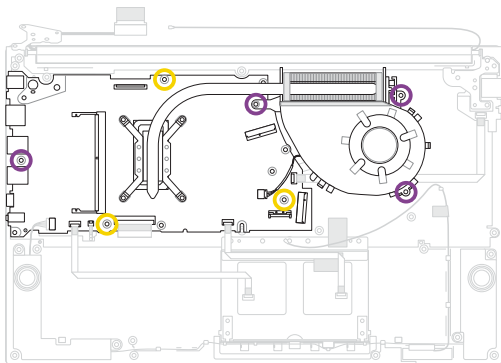

17" model

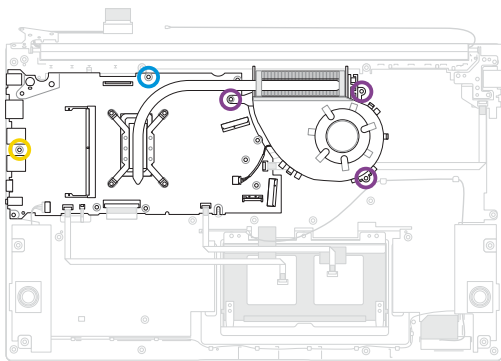

4. Disconnect the fan connector, then remove the fan.

NOTE: This step is only required when you are replacing the existing component with a new one.

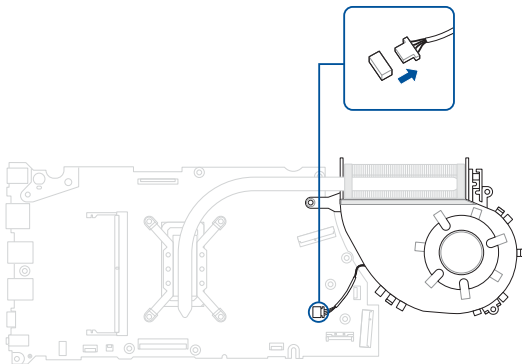

- Remove the heat sink screw(s) one by one in the sequence shown in the illustration below, then remove the heat sink.

IMPORTANT! Vertically lift the heat sink using the left side of the heat sink to prevent damage.

NOTE: This step is only required when you are replacing the existing component with a new one.

14"/15" model

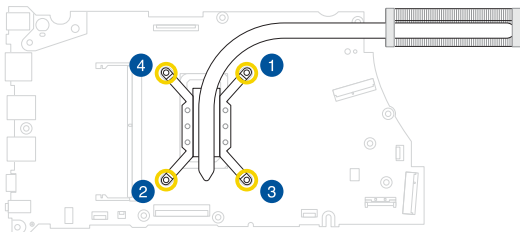

17" model

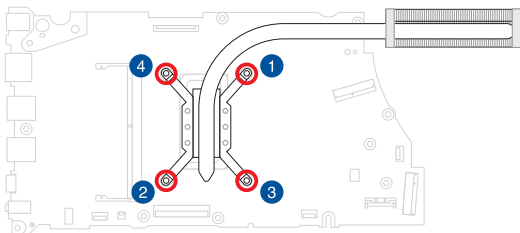

Installation

1. Install the heat sink on the motherboard, then secure the heat sink screw(s) one by one in the sequence shown in the illustration below.

NOTE: This step is only required when you are replacing the existing component with a new one.

14"/15" model

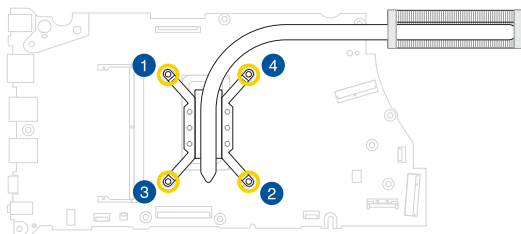

17" model

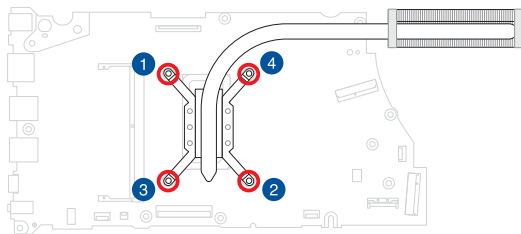

2. Install the fan, then reconnect the fan connector.

NOTE: This step is only required when you are replacing the existing component with a new one.

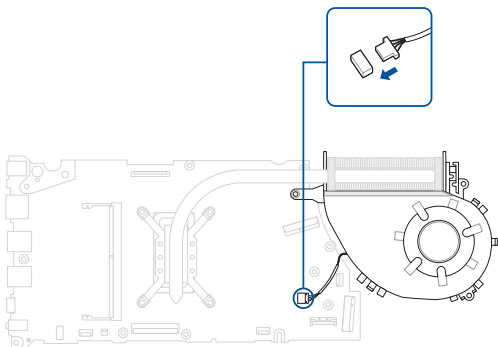

3. Align and install the motherboard with the heat sink and fan attached.
4. Secure the motherboard and fan using the screw(s) you removed earlier.

14" model

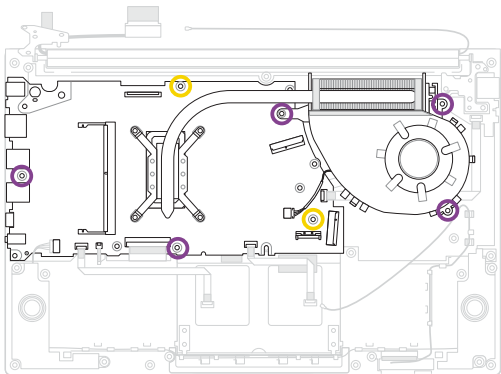

15" model

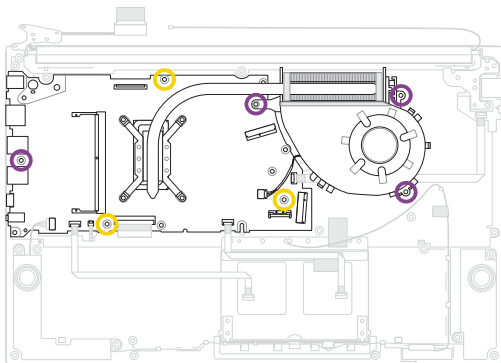

17" model

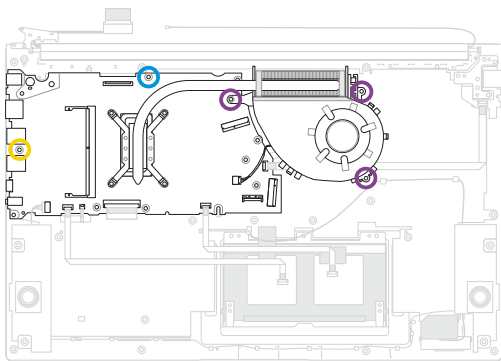

5. Place the hinge of the display panel module on the screw holes, then secure the hinge using the screw(s) you removed earlier.

14" model

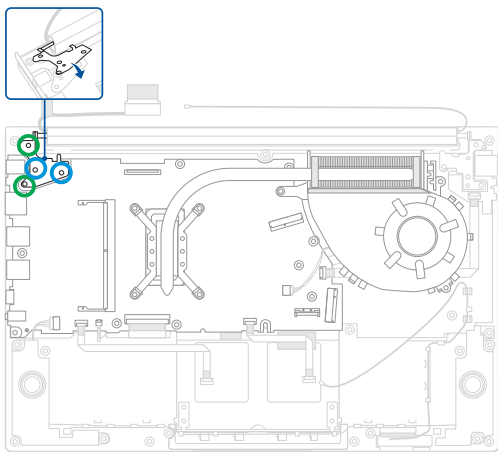

15" model

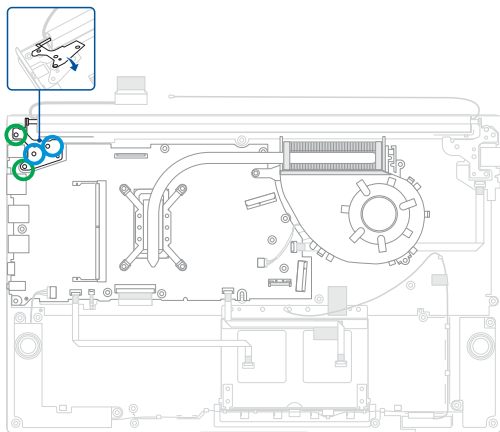

17" model

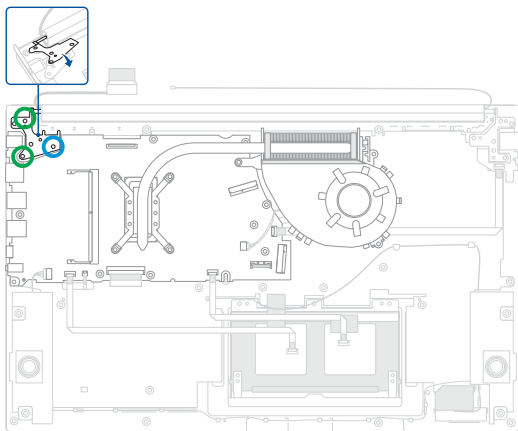

6. Route the cable(s) through the cable guide(s), then reconnect the cable(s) to the motherboard.

IMPORTANT! Damage may occur if cables are not properly routed through the cable guides. Confirm that all cables are routed through each of the indicated cable guides before proceeding.

7. Install the components you removed in the *Before you begin* section.

14" model

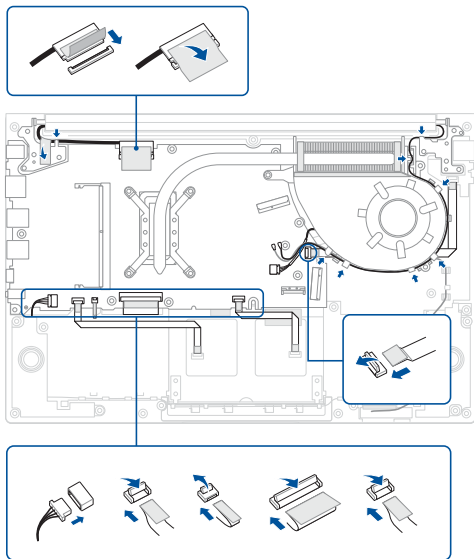

15" model

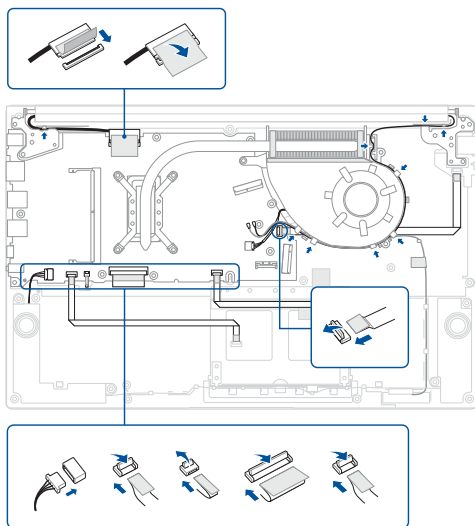

17" model

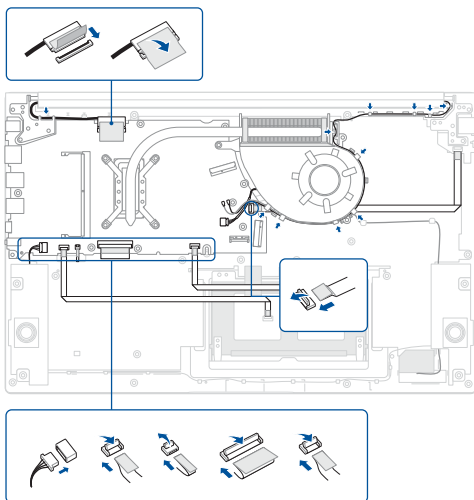

I/O board

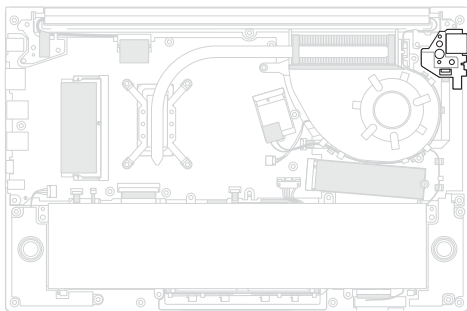

Before you begin

1. Read the **Safety Precautions** and **Pre-repair Checklist**.
2. Remove the following components:
 - Bottom cover
 - Battery

Screw list

14" model

- ⊕ M2.5 X 4.5L (2pcs)
- ⊕ M2.5 X 3.0L (2pcs)

15" model

● ⊕ M2.5 X 4.5L (2pcs)

● ⊕ M2.5 X 3.5L (2pcs)

17" model

● ⊕ M2.5 X 5.0L (2pcs)

● ⊕ M2.0 X 3.5L (1pc)

Removal

1. Disconnect the cable from the I/O board.

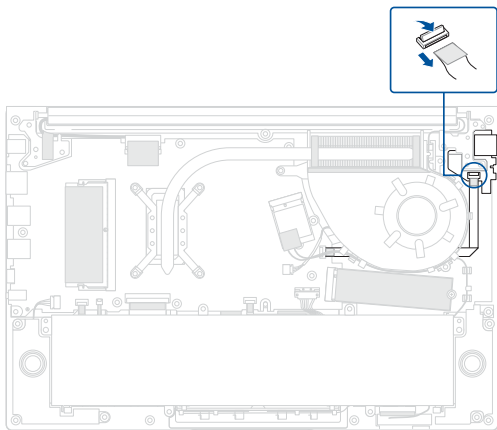

2. Remove the screw(s) from the hinge on the right side, then lift the hinge to a 90-degree position.
3. Remove the I/O board.

14" model

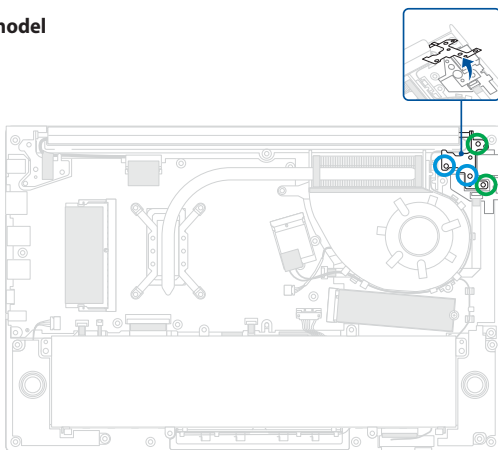

15" model

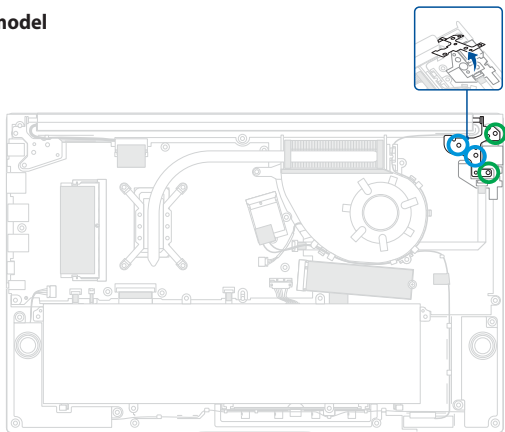

17" model

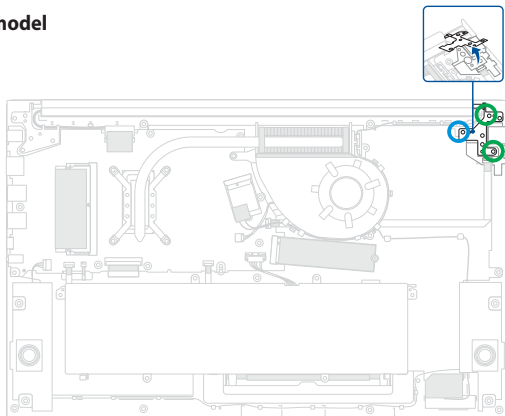

Installation

1. Install the I/O board.
2. Place the hinge of the display panel module on the screw holes, then secure the hinge using the screw(s) you removed earlier.

14" model

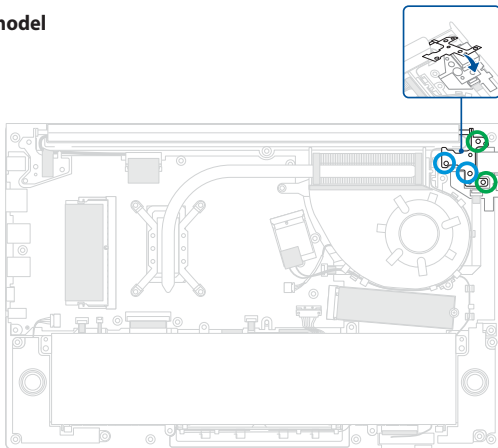

15" model

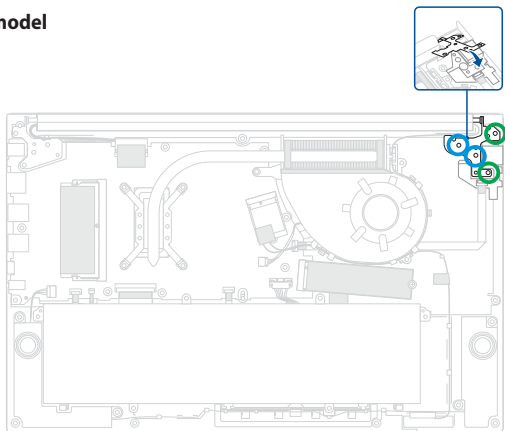

17" model

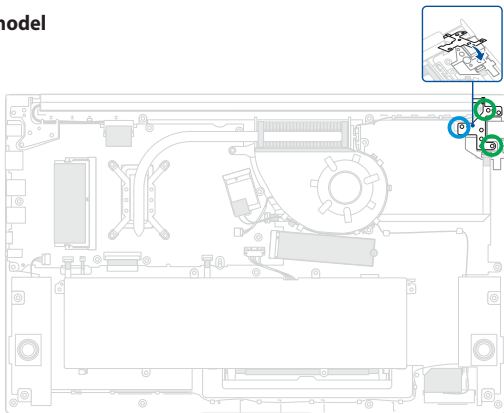

3. Reconnect the cable to the I/O board.
4. Install the components you removed in the *Before you begin* section.

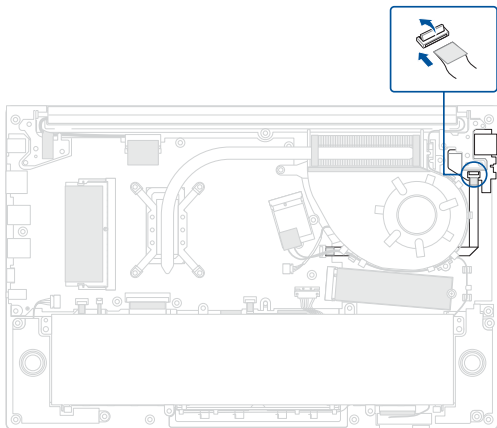

Touchpad

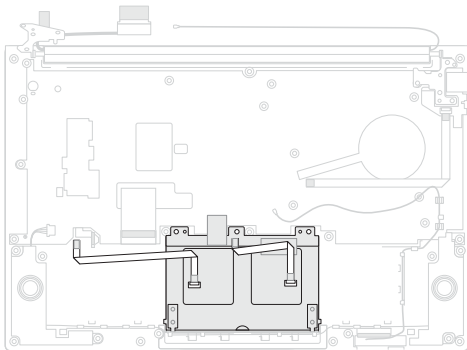

Before you begin

1. Read the **Safety Precautions** and **Pre-repair Checklist**.
2. Remove the following components:
 - Bottom cover
 - Battery
 - M.2 SSD module (on 14"/15" model)
 - WLAN module (on 14" model)
 - Fan module, heat sink and motherboard (on 14" model)

Screw list

- ⊕ M2.0 X 2.0L (3pcs)

Removal

1. Disconnect the cable(s) from the touchpad and remove the tape.

14" model

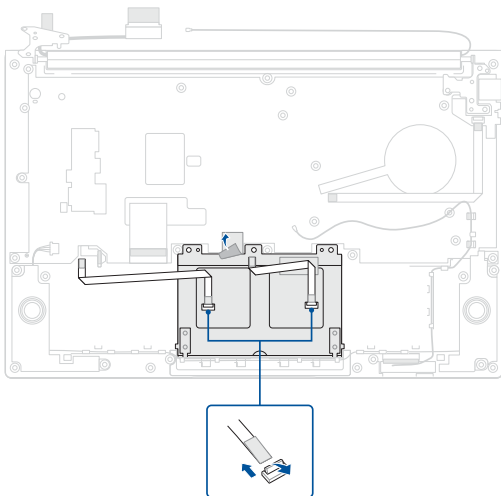

15" model

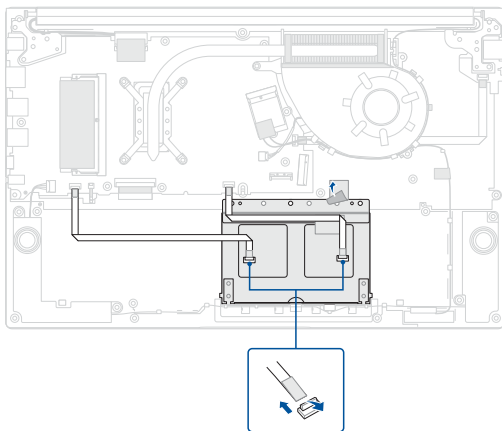

17" model

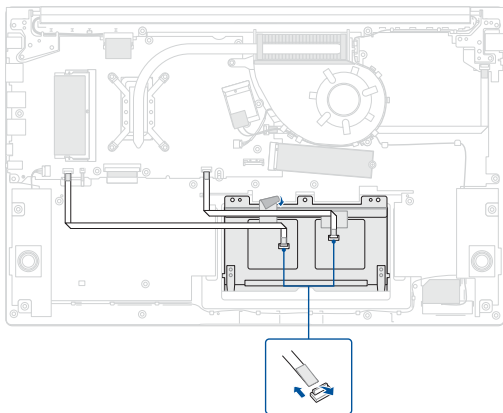

2. Remove the screw(s), then remove the touchpad.

14" model

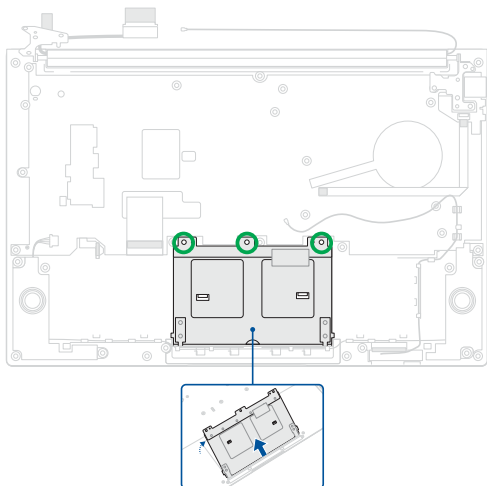

15" model

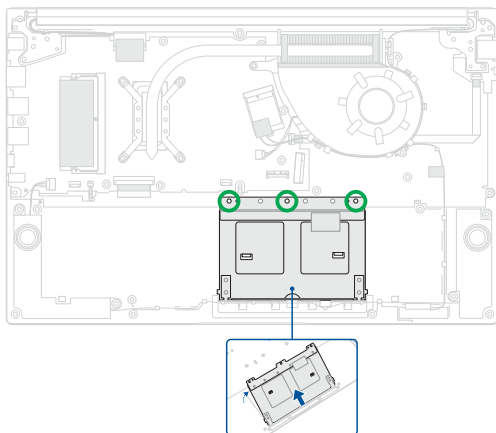

17" model

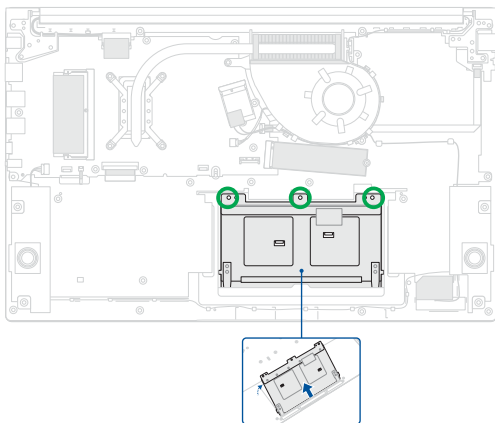

Installation

1. Install the touchpad, then secure the touchpad using the screw(s) you removed earlier.

14" model

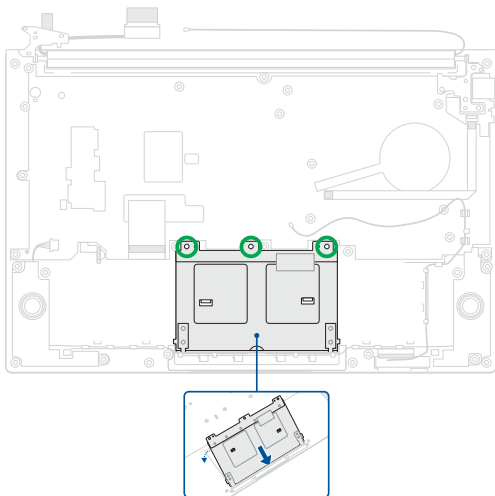

15" model

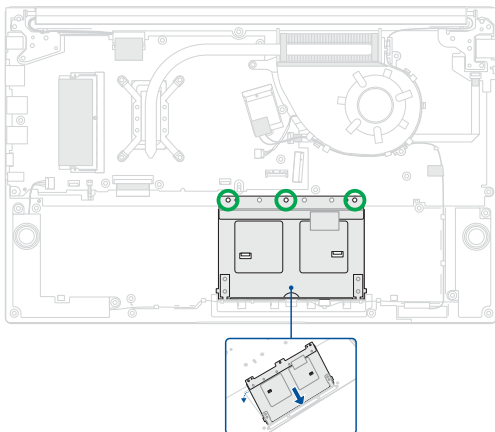

17" model

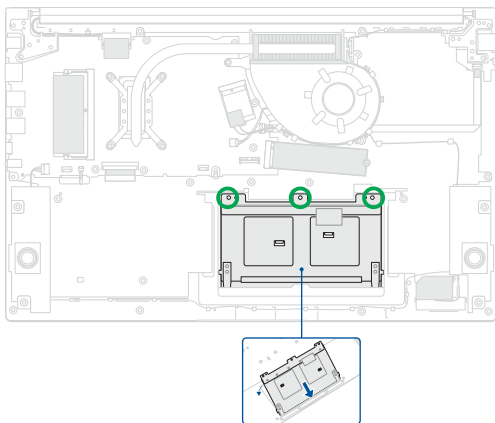

2. Reconnect the cable(s) to the touchpad and reattach the tape.
3. Install the components you removed in the *Before you begin* section.

14" model

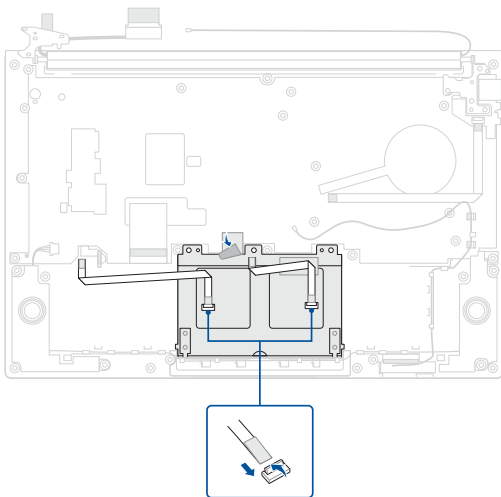

15" model

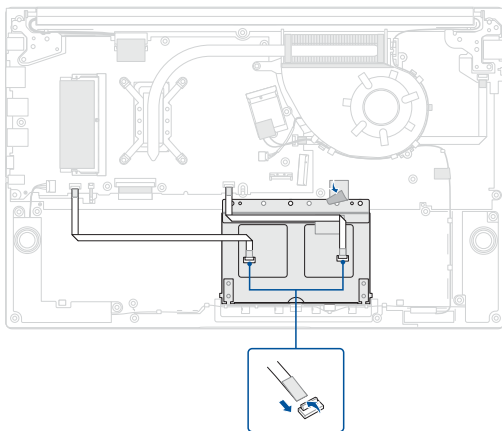

17" model

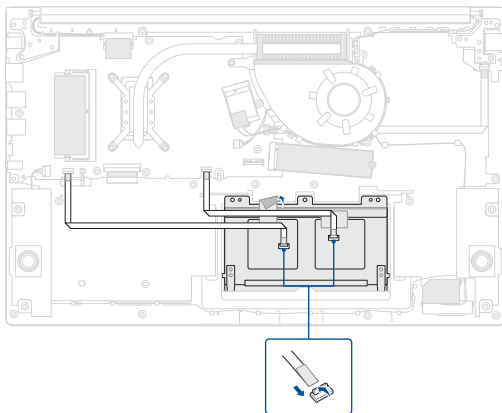

Display panel module

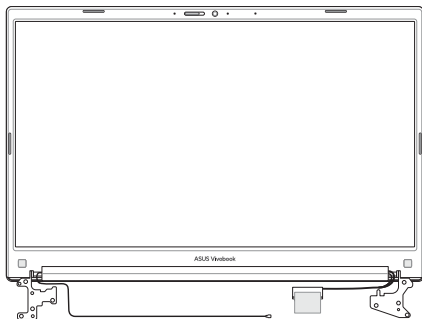

Before you begin

IMPORTANT! Do not bend the display panel in any way to avoid risk of display panel leakage.

1. Read the **Safety Precautions** and **Pre-repair Checklist**.
2. Remove the following components:
 - Bottom cover
 - Battery

Screw list

14" model

- ⊕ M2.5 X 4.5L (4pcs)
- ⊕ M2.5 X 3.0L (4pcs)

15" model

● ⊕ M2.5 X 4.5L (4pcs)

● ⊕ M2.5 X 3.5L (4pcs)

17" model

● ⊕ M2.5 X 5.0L (4pcs)

● ⊕ M2.0 X 3.5L (2pcs)

Removal

1. Place your device with the display panel hanging over the edge of the workspace as shown in the illustration below.

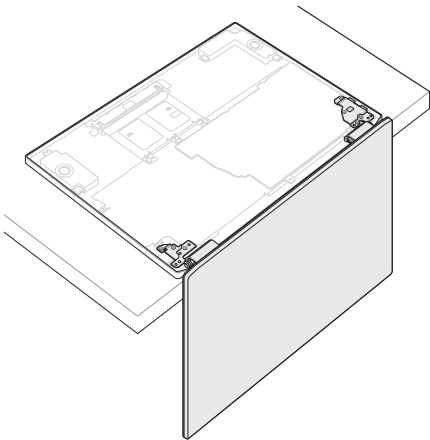

2. Disconnect the eDP cable and antenna cable, then remove the cable(s) from the cable guide(s).

14" model

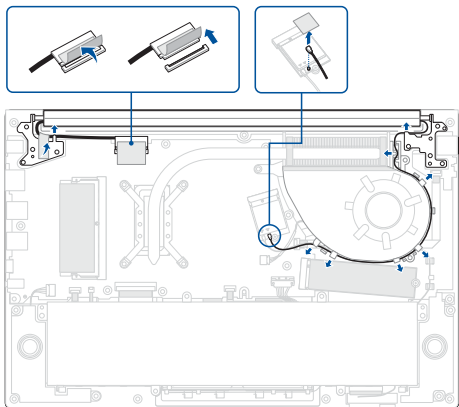

15" model

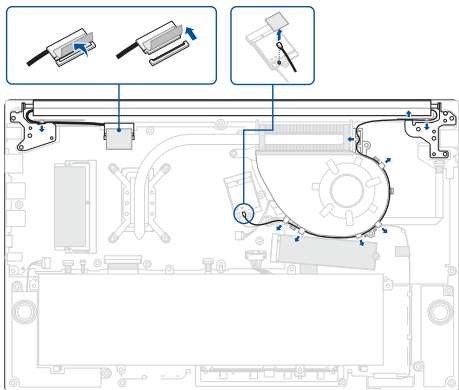

17" model

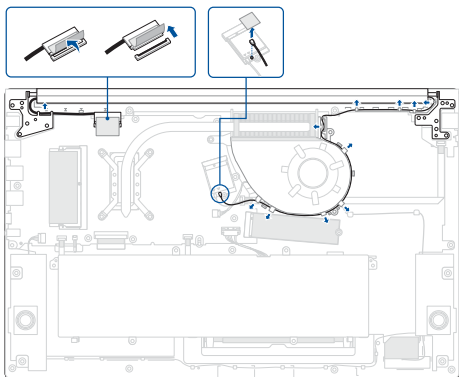

3. Remove the screw(s).

14" model

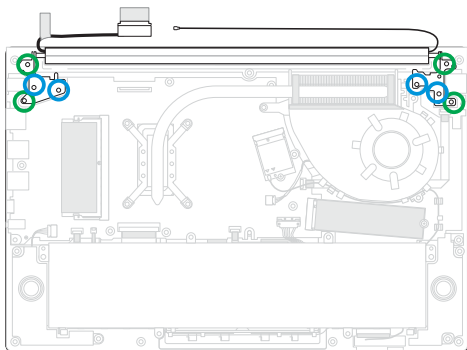

15" model

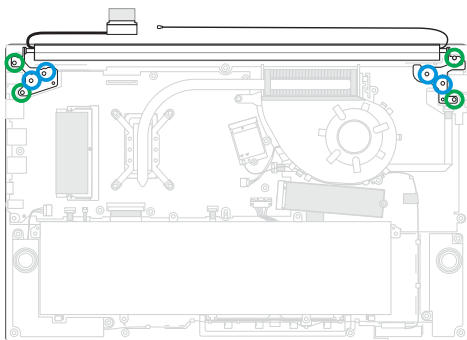

17" model

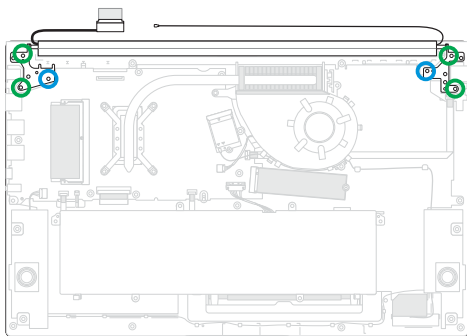

4. Remove the display panel module.

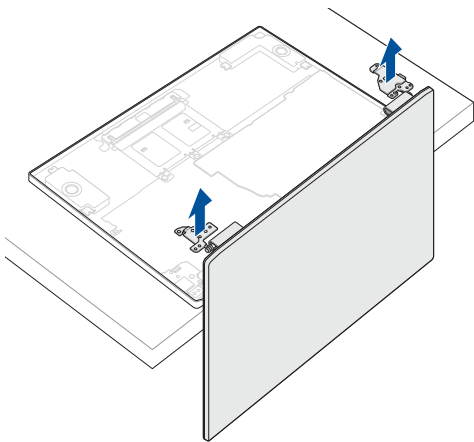

Installation

1. In the orientation shown, align and place the hinges of the display panel module on the screw holes.

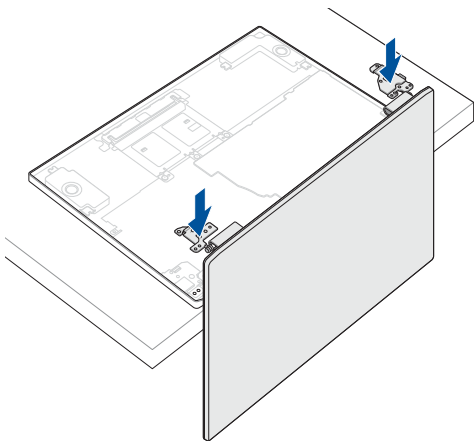

2. Secure the hinges using the screw(s) you removed earlier.

14" model

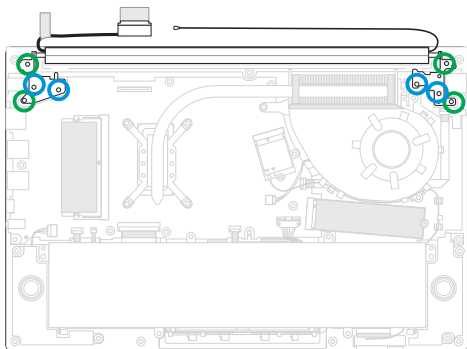

15" model

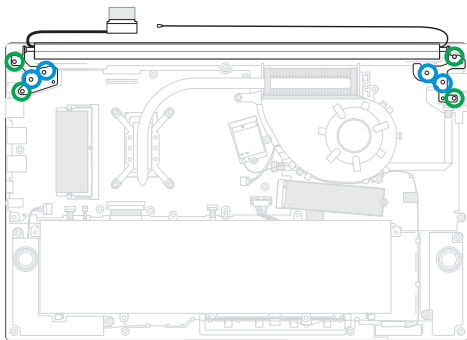

17" model

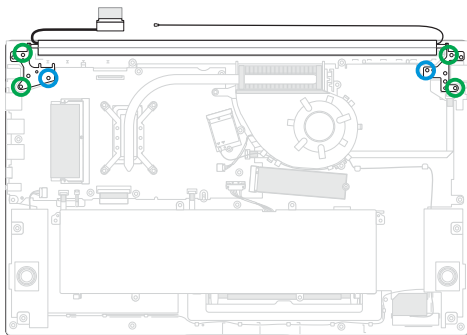

3. Route the eDP cable and antenna cable through the cable guide(s), then reconnect the cables.

IMPORTANT! Damage may occur if cables are not properly routed through the cable guides. Confirm that all cables are routed through each of the indicated cable guides before proceeding.

4. Install the components you removed in the *Before you begin* section.

14" model

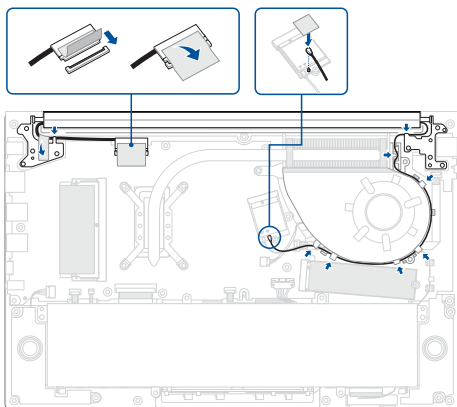

15" model

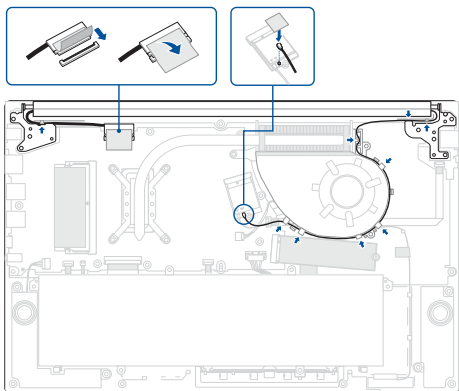

17" model

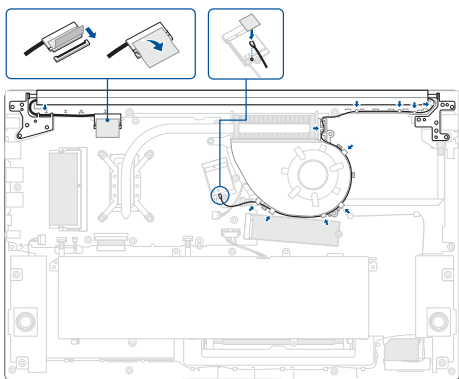

Display bezel

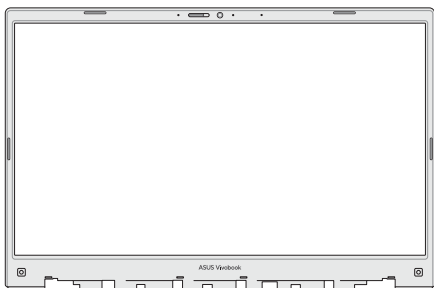

Before you begin

IMPORTANT! This component is fragile. Damage may occur if the service procedure is performed incorrectly. If you are uncertain about proceeding, stop and contact an authorized service center for assistance.

1. Read the **Safety Precautions** and **Pre-repair Checklist**.
2. Remove the following components:
 - Bottom cover
 - Battery
 - Display panel module

Screw list

14"/15" model

- ⊕ M2.5 X 3.5L (2pcs)

17" model

- ⊕ M2.5 X 3.0L (2pcs)

Removal

1. Remove the hinge cap as shown in the illustration below.

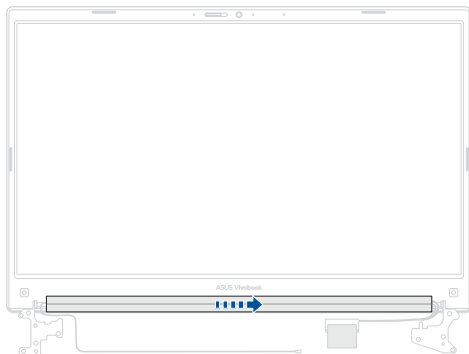

2. Remove the screw cover(s), then remove the screw(s).

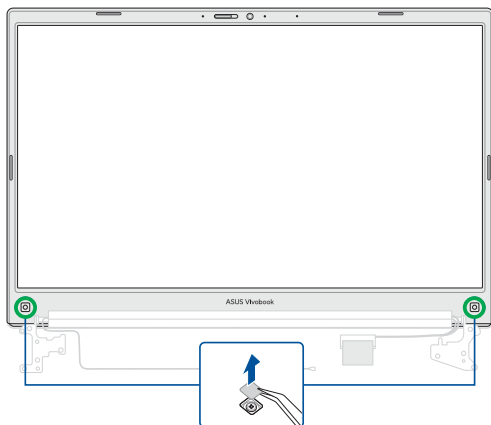

- Carefully pry the bezel loose, then remove the bezel.

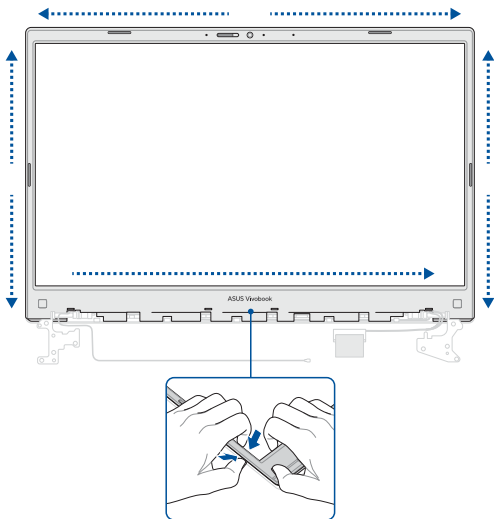

Installation

1. Remove the release liner(s) from the tape on the bezel.

NOTE: The tape cannot be reused. Remove any adhesive residue and use new tape when reinstalling components.

2. Align and install the bezel.

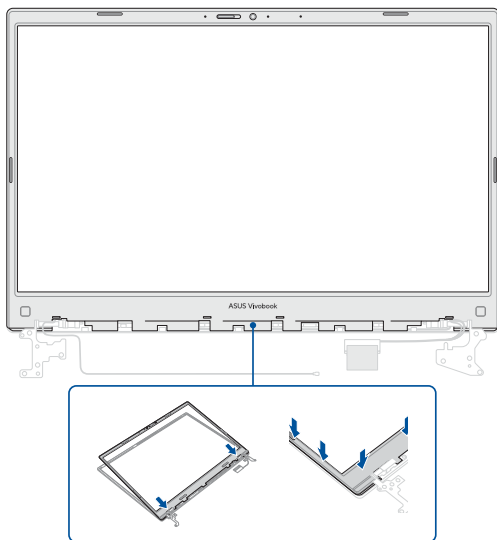

3. Secure the bezel using the screw(s) you removed earlier, then reattach the screw cover(s).

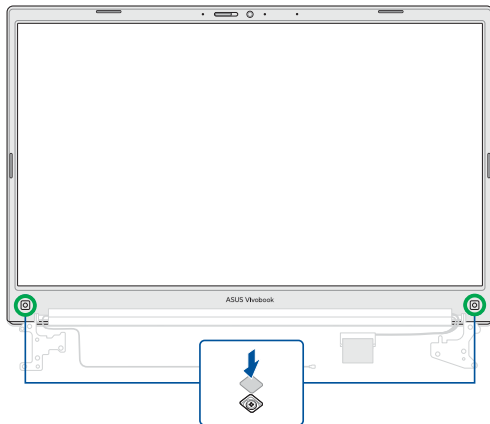

4. Install the hinge cap.
5. Install the components you removed in the *Before you begin* section.



Display hinges

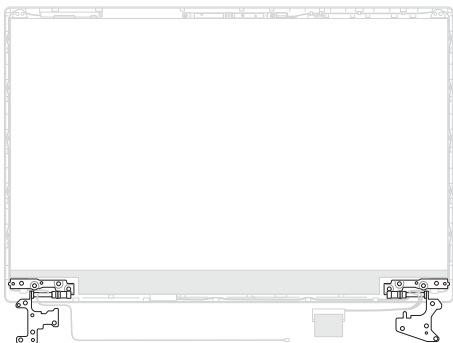

Before you begin

1. Read the **Safety Precautions** and **Pre-repair Checklist**.
2. Remove the following components:
 - Bottom cover
 - Battery
 - Display panel module
 - Display bezel

Screw list

14"/15" model

- ⊕ M2.5 X 3.0L (6pcs)

17" model

- ⊕ M2.5 X 3.0L (4pcs)

Removal

Remove the screw(s), then remove the hinges.

14" model

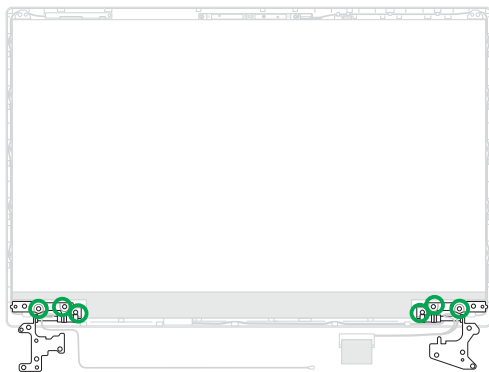

15" model



17" model



Installation

1. Install the hinges, then secure the hinges using the screw(s) you removed earlier.
2. Install the components you removed in the *Before you begin* section.

14" model

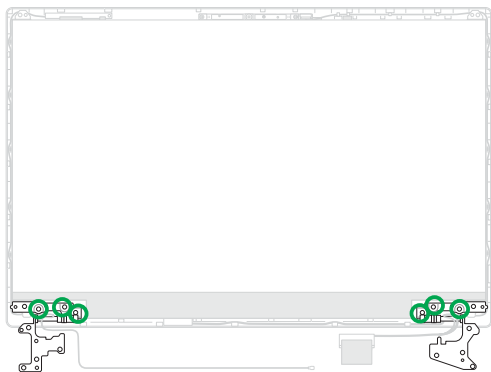

15" model



17" model



Display panel



Before you begin

IMPORTANT!

- This component is fragile. Damage may occur if the service procedure is performed incorrectly. If you are uncertain about proceeding, stop and contact an authorized service center for assistance.
 - Do not bend the display panel in any way to avoid risk of display panel leakage.
-

1. Read the **Safety Precautions** and **Pre-repair Checklist**.
2. Remove the following components:
 - Bottom cover
 - Battery
 - Display panel module
 - Display bezel
 - Display hinges

Screw list

14"model

- ⊕ M1.6 X 1.5L (2pcs)

15"/17"model

- ⊕ M2.0 X 2.5L (2pcs)

Removal

1. Remove the screw(s).



2. Lift the display panel, then disconnect the cable from the rear side of the display panel.

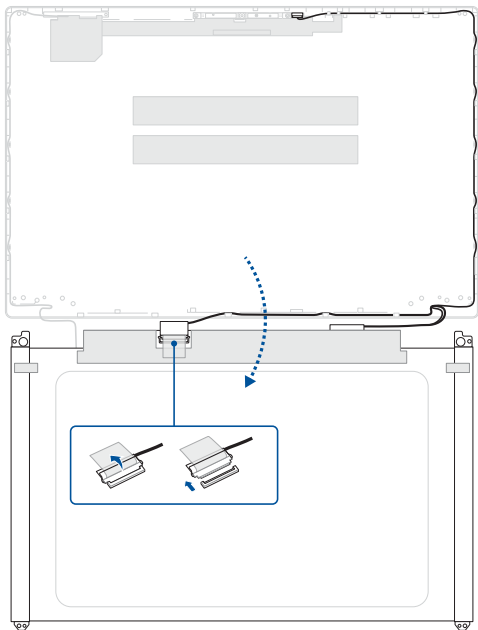

Installation

1. Place the display panel on a clean surface with the rear side facing upwards.
2. Remove the release liner(s) from the tape on the display panel brackets, then align and install the display panel brackets onto the rear side of display panel.

IMPORTANT! The display panel brackets are not removable and cannot be reused. Ensure that the display panel brackets are oriented correctly before installation.

3. Reattach the tape on the brackets.



4. Reconnect the cable to the rear side of the display panel.
5. Align and install the display panel.

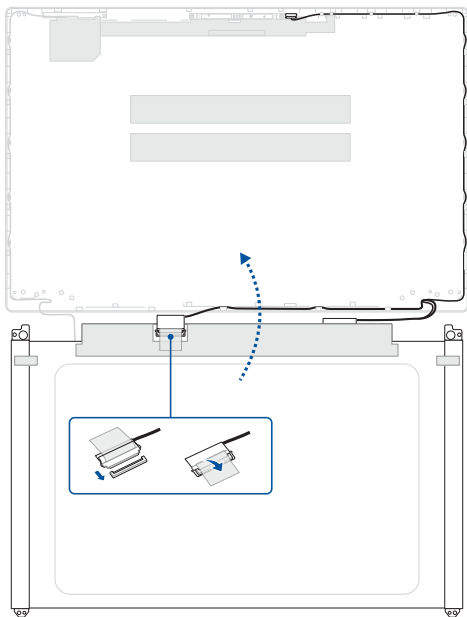

6. Secure the display panel using the screw(s) you removed earlier.
7. Install the components you removed in the *Before you begin* section.



Camera module

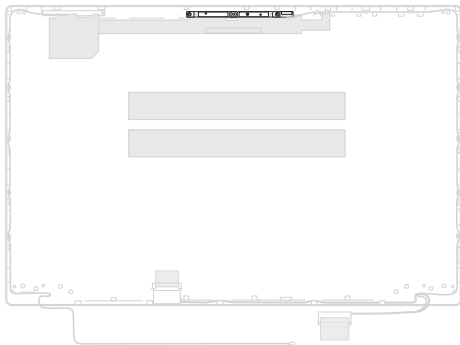

Before you begin

IMPORTANT! This component is fragile. Damage may occur if the service procedure is performed incorrectly. If you are uncertain about proceeding, stop and contact an authorized service center for assistance.

1. Read the **Safety Precautions** and **Pre-repair Checklist**.
2. Remove the following components:
 - Bottom cover
 - Battery
 - Display panel module
 - Display bezel
 - Display hinges
 - Display panel

Removal

Disconnect the cable and carefully remove the camera module, then remove the rubber caps from the camera module.

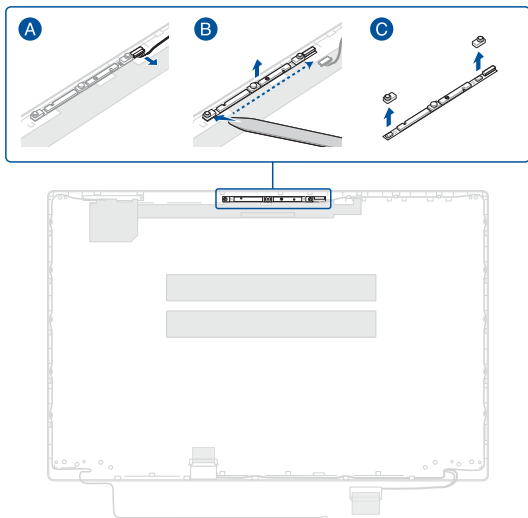

Installation

1. Attach the rubber caps to the camera module, then install the camera module and reconnect the cable to the camera module.
2. Install the components you removed in the *Before you begin* section.

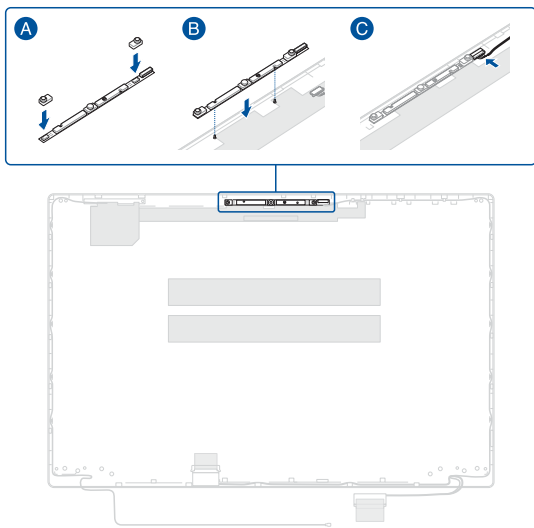

Top cover

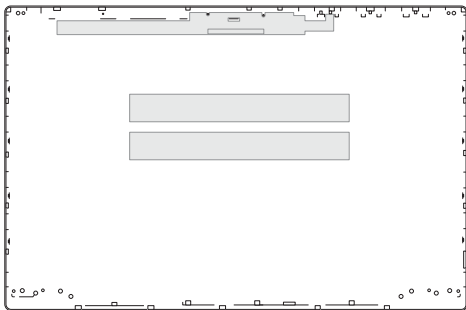

Before you begin

1. Read the **Safety Precautions** and **Pre-repair Checklist**.
2. Remove the following components:
 - Bottom cover
 - Battery
 - Display panel module
 - Display bezel
 - Display hinges
 - Display panel
 - Camera module

Removal

Remove the cable(s) as shown in the illustration below.

IMPORTANT! The antenna cable(s) cannot be reused once removed.

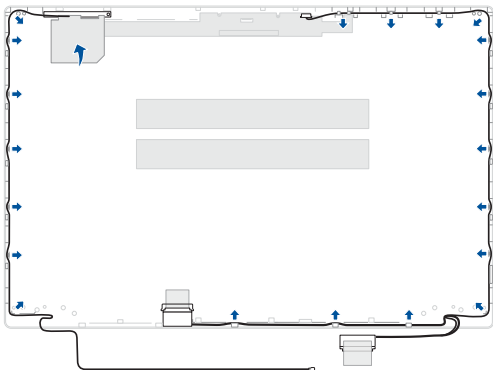

Installation

1. Install the cable(s) and route the cable(s) through the cable guide(s).

IMPORTANT! Damage may occur if cables are not properly routed through the cable guides. Confirm that all cables are routed through each of the indicated cable guides before proceeding.

2. Install the components you removed in the *Before you begin* section.

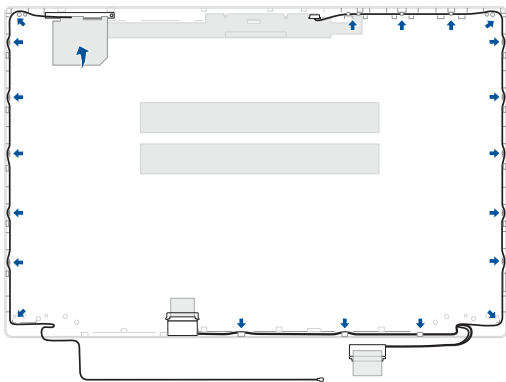

Keyboard module

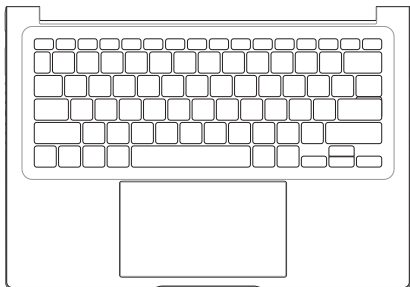

Before you begin

1. Read the **Safety Precautions** and **Pre-repair Checklist**.
2. Remove the following components:
 - Bottom cover
 - Battery
 - M.2 SSD module
 - WLAN module
 - Speakers
 - Fan module, heat sink and motherboard
 - I/O board
 - Touchpad
 - Display panel module

Removal

Remove the antenna cable(s) as shown in the illustration below.

IMPORTANT! The antenna cable(s) cannot be reused once removed.

14" model

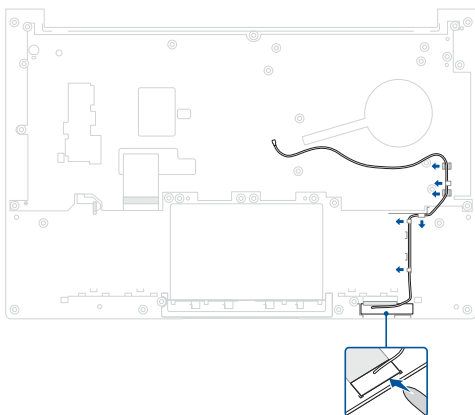

15" model

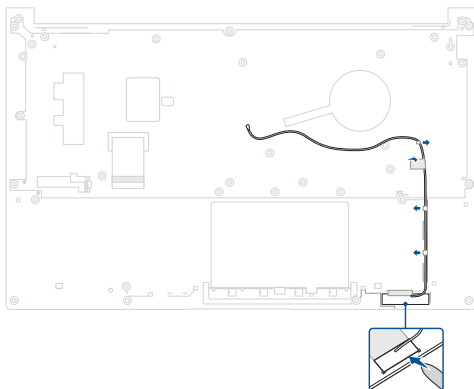

17" model

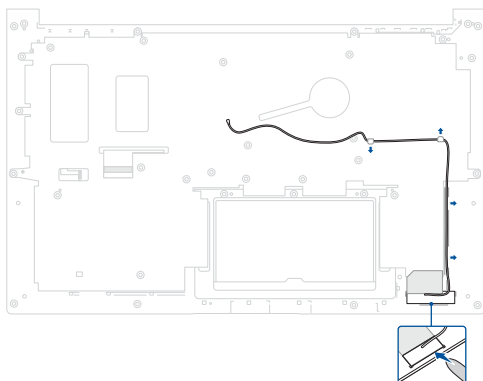

Installation

1. Install the antenna cable(s).
2. Route the cable(s) through the cable guide(s) and reattach the tape.

IMPORTANT! Damage may occur if cables are not properly routed through the cable guides. Confirm that all cables are routed through each of the indicated cable guides before proceeding.

3. Install the components you removed in the *Before you begin* section.

14" model

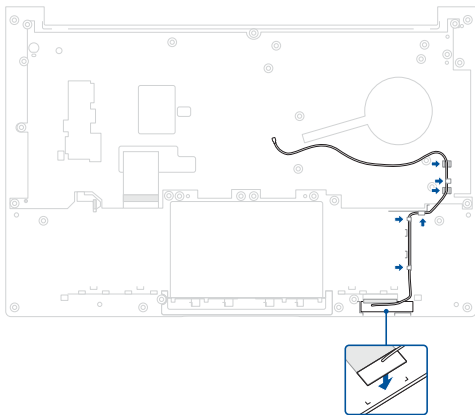

15" model

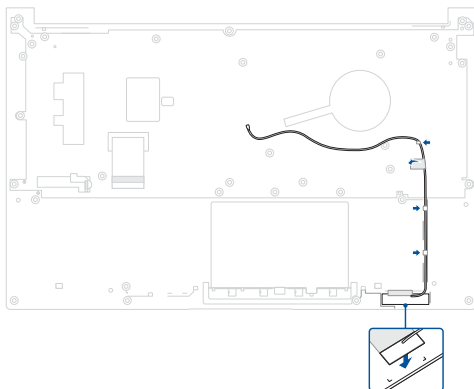

17" model

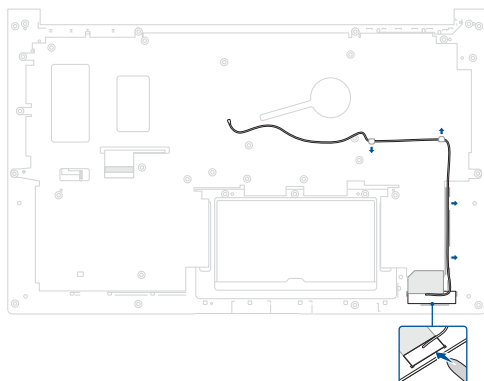

Appendices

Wiring and connection diagrams

Top View

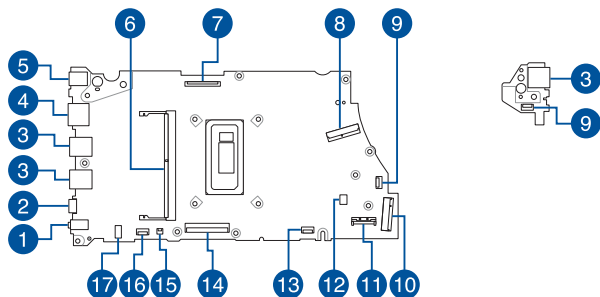

Bottom View

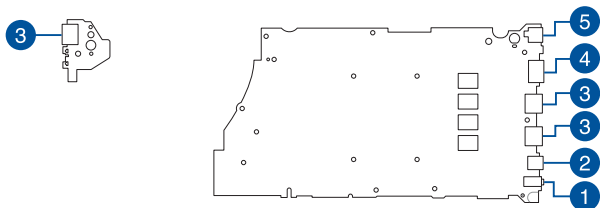

1. Audio connector
2. USB Type-C® connector
3. USB Type-A connector
4. HDMI connector
5. Power supply connector
6. RAM module slot
7. eDP connector
8. WLAN connector
9. I/O FFC connector
10. M.2 SSD connector
11. Battery connector
12. Fan connector
13. Touchpad connector
14. Keyboard connector
15. Keyboard backlight connector
16. Fingerprint sensor connector
17. Speaker connector

