

E23736

First Edition / December 2024

IN SEARCH OF INCREDIBLE



Service Manual

ASUS

COPYRIGHT INFORMATION

No part of this manual, including the products and software described in it, may be reproduced, transmitted, transcribed, stored in a retrieval system, or translated into any language in any form or by any means, except documentation kept by the purchaser for backup purposes, without the express written permission of ASUSTeK COMPUTER INC. ("ASUS").

ASUS PROVIDES THIS MANUAL "AS IS" WITHOUT WARRANTY OF ANY KIND, EITHER EXPRESS OR IMPLIED, INCLUDING BUT NOT LIMITED TO THE IMPLIED WARRANTIES OR CONDITIONS OF MERCHANTABILITY OR FITNESS FOR A PARTICULAR PURPOSE. IN NO EVENT SHALL ASUS, ITS DIRECTORS, OFFICERS, EMPLOYEES OR AGENTS BE LIABLE FOR ANY INDIRECT, SPECIAL, INCIDENTAL, OR CONSEQUENTIAL DAMAGES (INCLUDING DAMAGES FOR LOSS OF PROFITS, LOSS OF BUSINESS, LOSS OF USE OR DATA, INTERRUPTION OF BUSINESS AND THE LIKE), EVEN IF ASUS HAS BEEN ADVISED OF THE POSSIBILITY OF SUCH DAMAGES ARISING FROM ANY DEFECT OR ERROR IN THIS MANUAL OR PRODUCT.

Products and corporate names appearing in this manual may or may not be registered trademarks or copyrights of their respective companies, and are used only for identification or explanation and to the owners' benefit, without intent to infringe.

SPECIFICATIONS AND INFORMATION CONTAINED IN THIS MANUAL ARE FURNISHED FOR INFORMATIONAL USE ONLY, AND ARE SUBJECT TO CHANGE AT ANY TIME WITHOUT NOTICE, AND SHOULD NOT BE CONSTRUED AS A COMMITMENT BY ASUS. ASUS ASSUMES NO RESPONSIBILITY OR LIABILITY FOR ANY ERRORS OR INACCURACIES THAT MAY APPEAR IN THIS MANUAL, INCLUDING THE PRODUCTS AND SOFTWARE DESCRIBED IN IT.

Copyright © 2024 ASUSTeK COMPUTER INC. All Rights Reserved.

LIMITATION OF LIABILITY

Circumstances may arise where because of a default on ASUS' part or other liability, you are entitled to recover damages from ASUS. In each such instance, regardless of the basis on which you are entitled to claim damages from ASUS, ASUS is liable for no more than damages for bodily injury (including death) and damage to real property and tangible personal property; or any other actual and direct damages resulted from omission or failure of performing legal duties under this Warranty Statement, up to the listed contract price of each product.

ASUS will only be responsible for or indemnify you for loss, damages or claims based in contract, tort or infringement under this Warranty Statement.

This limit also applies to ASUS' suppliers and its reseller. It is the maximum for which ASUS, its suppliers, and your reseller are collectively responsible.

UNDER NO CIRCUMSTANCES IS ASUS LIABLE FOR ANY OF THE FOLLOWING: (1) THIRD-PARTY CLAIMS AGAINST YOU FOR DAMAGES; (2) LOSS OF, OR DAMAGE TO, YOUR RECORDS OR DATA; OR (3) SPECIAL, INCIDENTAL, OR INDIRECT DAMAGES OR FOR ANY ECONOMIC CONSEQUENTIAL DAMAGES (INCLUDING LOST PROFITS OR SAVINGS), EVEN IF ASUS, ITS SUPPLIERS OR YOUR RESELLER IS INFORMED OF THEIR POSSIBILITY.

SERVICE AND SUPPORT

Visit our multi-language website at <https://www.asus.com/support/>.

Table of Contents

Chapter 1: Introduction

Disclaimer	8
Safety precautions.....	8
Pre-repair checklist.....	10
Repair tools.....	11
Accessories	11
Diagnostic tools.....	11
Major components	12

Chapter 2: Service Procedures

Bottom cover	16
Removal.....	17
Installation.....	19
Battery	21
Removal.....	22
Installation.....	25
M.2 SSD module	29
Removal.....	30
Installation.....	32
RAM module	34
Removal.....	35
Installation.....	36
WLAN module.....	37
Removal.....	38
Installation.....	39

Speakers	40
Removal.....	41
Installation.....	43
Fan module	45
Removal.....	46
Installation.....	49
Heat sink and motherboard	52
Removal.....	54
Installation.....	59
I/O board	64
Removal.....	65
Installation.....	69
Touchpad	73
Removal.....	74
Installation.....	78
Display panel module	82
Removal.....	83
Installation.....	88
Display bezel	92
Removal.....	93
Installation.....	95
Display hinges.....	97
Removal.....	98
Installation.....	99

Display panel.....	100
Removal.....	101
Installation.....	103
Camera module	105
Removal.....	106
Installation.....	108
Top cover.....	110
Removal.....	111
Installation.....	112
Keyboard module.....	113
Removal.....	114
Installation.....	115

Appendices

Wiring and connection diagrams.....	118
-------------------------------------	-----

Chapter 1: ***Introduction***

Disclaimer

ASUS is not responsible for direct, indirect, intentional or unintentional damages resulting from improper installation and operation.

Safety precautions

- Before handling components, use a grounded wrist strap or touch a safely grounded object to avoid damaging them due to static electricity.
- Keep liquids or moisture away from your device to avoid short circuits.
- Remove rings, watches, and any other metal objects from your hands.
- Hold components by the edges to avoid touching the ICs.
- Properly install all components before connecting the AC power.
- Do not use power adapters or batteries from other devices to reduce the risk of injury to persons due to fire or explosion. Use only certified power adapters or batteries supplied by the manufacturer or authorized retailers.
- Detach all clips or flaps before removing cables to prevent damage.

- Disconnect cables, connectors, and power plugs by pulling the plug evenly to avoid damage.
- Use the correct screw models on your device to prevent damage.
- Confirm that the cable orientation is correct before connecting any cables.
- Fully remove all adhesive residue after removing and before installing any components.
- Photograph the appearance of cables, cable routing, connectors, and screws for later reference before proceeding with each step.

Pre-repair checklist

- Read the entire manual before starting any service procedures and follow all instructions.
- Back up the data on your device.
- Place your device on a clean and stable surface.
- Turn off your device.
- Disconnect all connected peripherals and cables.
- Disconnect all power cables and remove the battery pack (if applicable).

IMPORTANT!

- If you are uncertain about performing the described service procedures, stop and contact an authorized service center for assistance.
- Purchase replacement components from authorized retailers of this device to ensure maximum compatibility and reliability.

NOTE:

- The illustrations are for reference only.
 - The service procedures described in this manual depend on the model configuration and may not reflect the entire servicing process. To service components that are not covered in this manual, please visit an authorized service center for further assistance.
 - Keep all adhesive tape, insulating materials, screws, and other removable items in a safe place until the service procedure is completed, as they may be needed during installation.
-

Repair tools



Screwdriver



Plastic blade



Tweezers

Accessories



Power adapter

Diagnostic tools

Use ASUS System Diagnostics after completing any service procedures to ensure that all components are working properly.

For more information, visit www.asus.com/support/FAQ/1048490/.

Major components

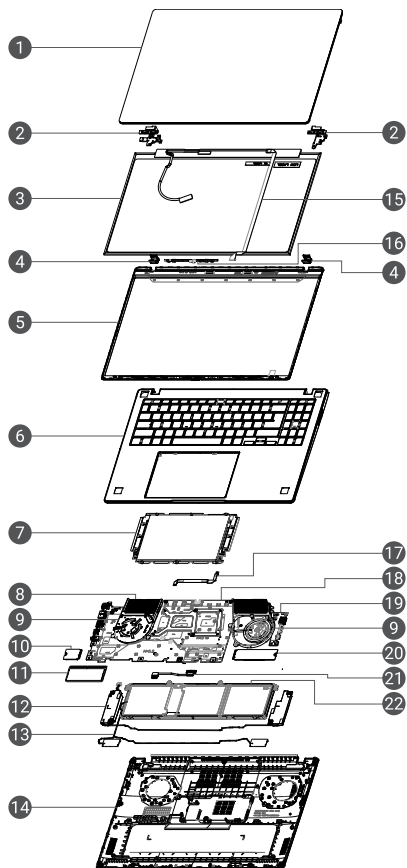

1. Top cover
2. Display hinges
3. Display panel
4. Hinge caps
5. Display bezel
6. Keyboard module
7. Touchpad
8. Heat sink
9. Fans
10. WLAN module
11. RAM module
12. Speakers
13. Antenna cables
14. Bottom cover
15. eDP cable
16. Camera module
17. Touchpad cable
18. Motherboard
19. I/O board
20. M.2 SSD module
21. Battery power cable
22. Battery

Chapter 2: ***Service Procedures***

Bottom cover

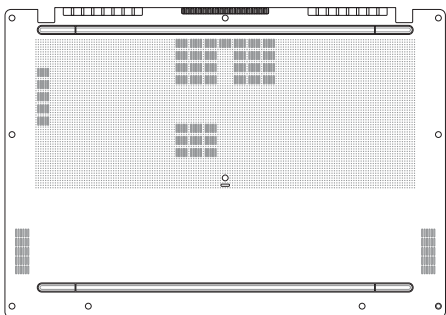

Before you begin

Read the **Safety Precautions** and complete the **Pre-repair Checklist**.

Screw list

- ⊕ M2.0 X 7.0L (6pcs)
- ⊕ M2.0 X 4.0L (3pcs)
- ⊕ M2.0 X 4.0L captive screw (1pc)

Removal

1. Remove the screw(s) from the bottom cover.
2. Loosen the captive screw located at the bottom right corner of the bottom cover.

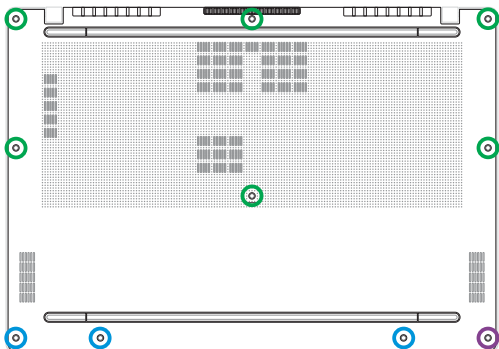

3. Use the plastic blade to pry open the indicated area of the bottom cover as shown in the illustration below.

IMPORTANT! Avoid sliding the plastic blade along the side of your device or air vents to prevent damage.

4. Remove the bottom cover.

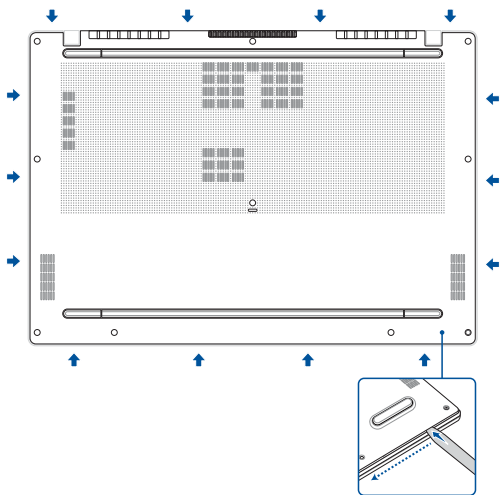

Installation

1. Install the bottom cover.

NOTE: When replacing the existing component with a new one, ensure you move the washer from the old component to the new bottom cover.

2. Gently press down on the bottom cover until it clicks into place.

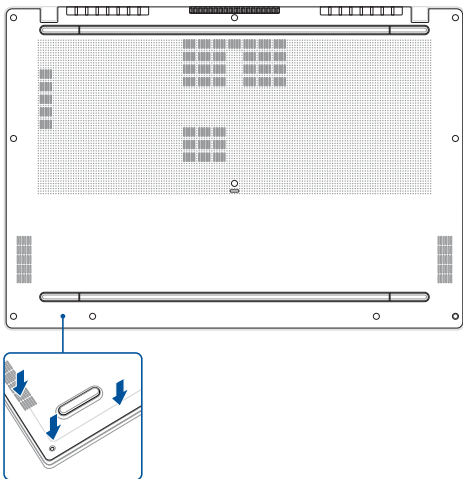

3. Tighten the captive screw located at the bottom right corner of the bottom cover.
4. Secure the bottom cover using the screw(s) you removed earlier.

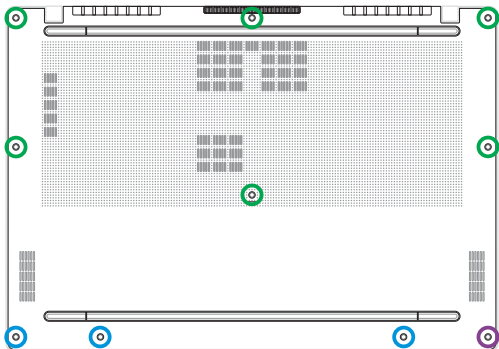

Battery

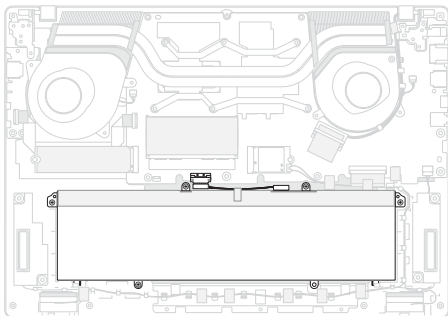

Before you begin

1. Read the **Safety Precautions** and **Pre-repair Checklist**.
2. Remove the bottom cover.

Screw list

- ⊕ M2.0 X 4.0L (5pcs)

Removal

1. Disconnect the battery power cable.

IMPORTANT!

- Disconnect the battery power cable by lifting the side with the red wires first.
 - Serious risk of fire or explosion may occur if the battery is punctured. If you are uncertain about proceeding, stop and contact an authorized service center for assistance.
-

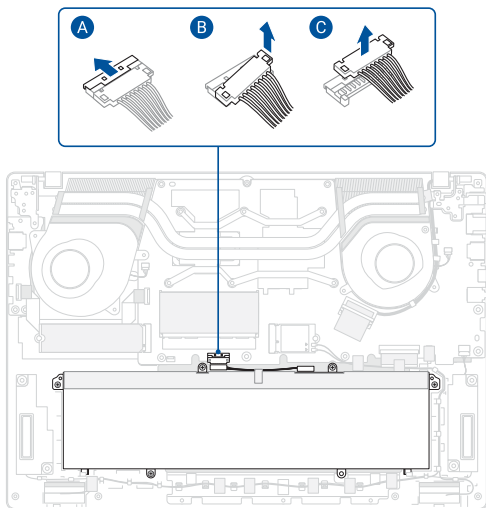

2. Remove the screw(s).
3. Remove the battery.

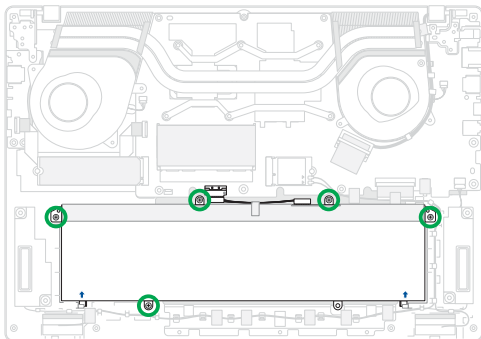

4. Remove the tape, then remove the battery power cable.

NOTE: This step is only required when you are replacing the existing component with a new one.

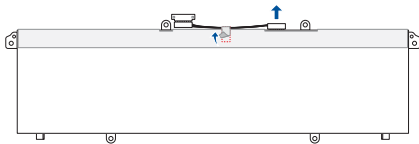

Installation

1. Align and attach the tape on the new battery as shown in the illustration below.

NOTE:

- This step is only required when you are replacing the existing component with a new one.
 - The tape cannot be reused. Use new tape when replacing the battery with a new one.
-

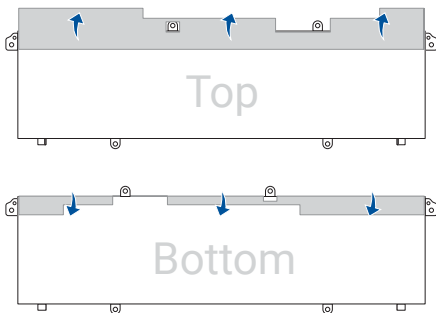

2. Connect the battery power cable to the battery, then reattach the tape.

NOTE: This step is only required when you are replacing the existing component with a new one.

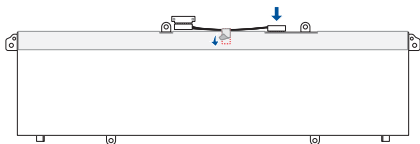

3. Install the battery.
4. Secure the battery using the screw(s) you removed earlier.

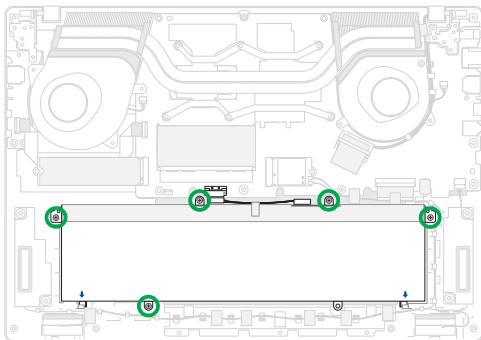

5. Reconnect the battery power cable.
6. Install the components you removed in the *Before you begin* section.

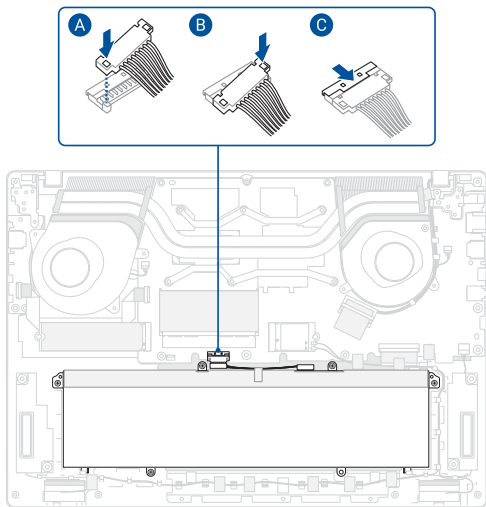

M.2 SSD module

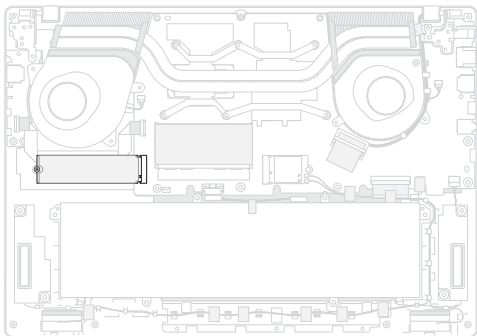

Before you begin

1. Read the **Safety Precautions** and **Pre-repair Checklist**.
2. Remove the bottom cover and disconnect the battery power cable.

Screw list

- ⊕ M2.0 X 3.5L (1pc)

Removal

1. Remove the screw, then remove the M.2 SSD module from the motherboard.

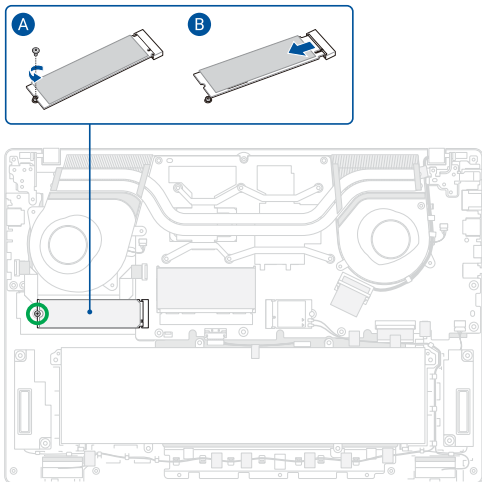

2. Remove the absorber sheet.

NOTE: This step is only required when you are replacing the existing component with a new one.

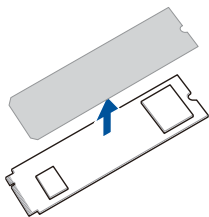

Installation

1. Attach the absorber sheet to the M.2 SSD module.

NOTE: This step is only required when you are replacing the existing component with a new one.

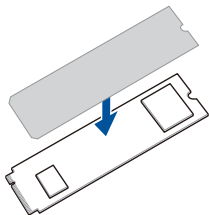

2. Align and insert the M.2 SSD module into the M.2 connector on the motherboard, then secure the M.2 SSD module using the screw you removed earlier.
3. Install the components you removed in the *Before you begin* section.

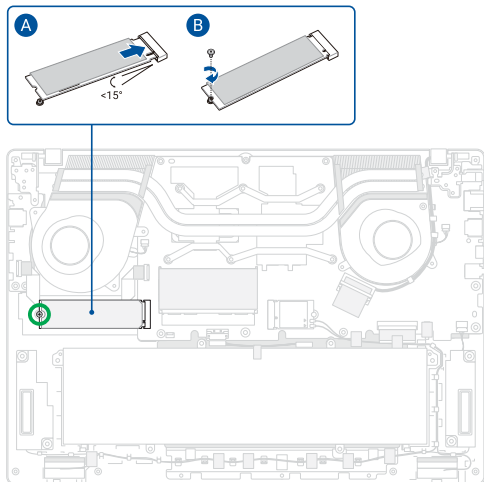

RAM module

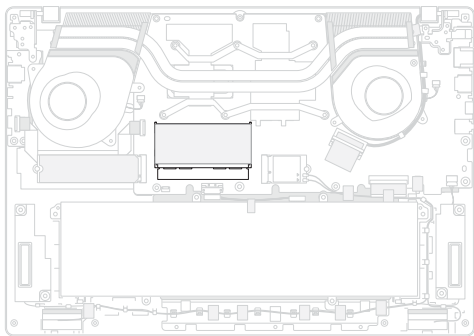

Before you begin

1. Read the **Safety Precautions** and **Pre-repair Checklist**.
2. Remove the bottom cover and disconnect the battery power cable.

Removal

Lift the absorber sheet, then push the clips outwards to remove the RAM module.

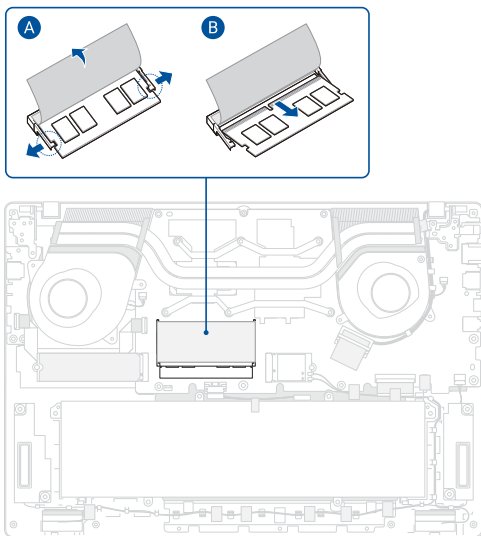

Installation

1. Align and insert the RAM module into the RAM module slot, then put the absorber sheet back.
2. Install the components you removed in the *Before you begin* section.

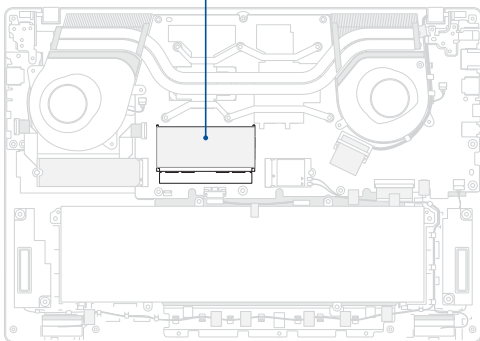
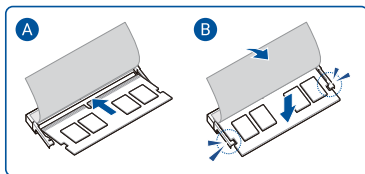

WLAN module

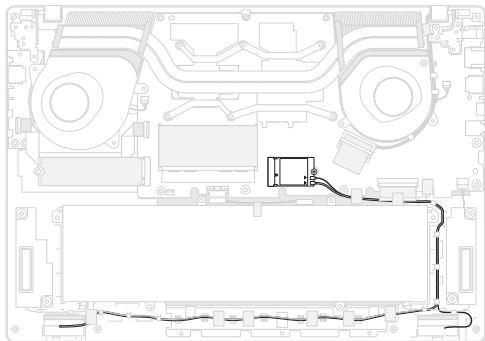

Before you begin

1. Read the **Safety Precautions** and **Pre-repair Checklist**.
2. Remove the bottom cover and disconnect the battery power cable.

Screw list

- ⊕ M2.0 X 3.5L (1pc)

Removal

Disconnect the antenna cable(s), then remove the screw and remove the WLAN module.

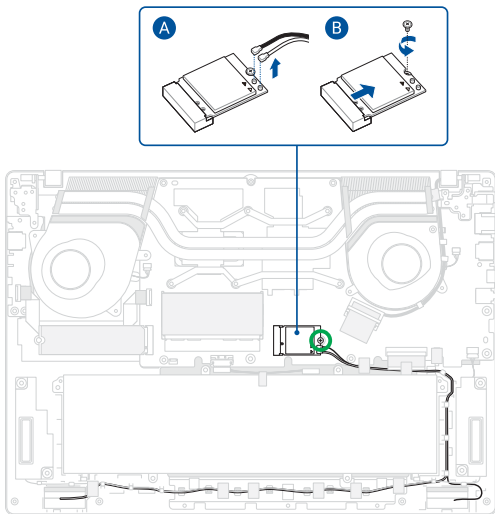

Installation

1. Install the WLAN module, then secure the WLAN module using the screw you removed earlier and reconnect the antenna cable(s).
2. Install the components you removed in the *Before you begin* section.

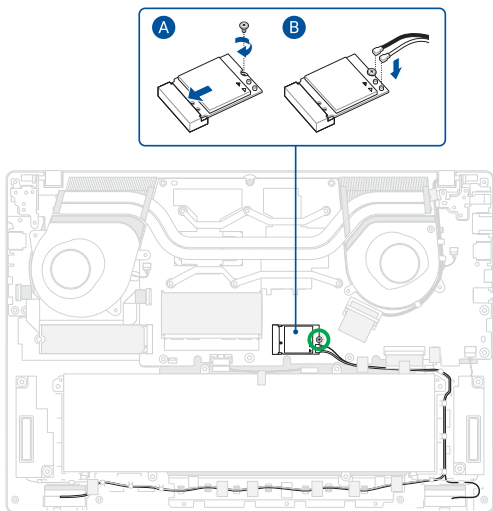

Speakers

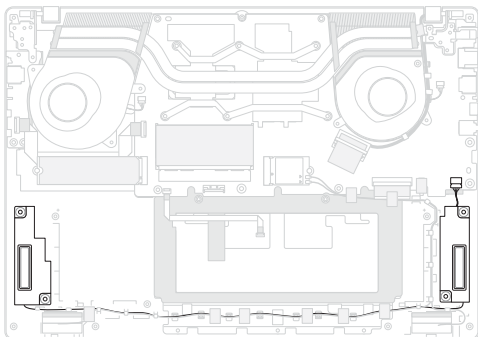

Before you begin

1. Read the **Safety Precautions** and **Pre-repair Checklist**.
2. Remove the bottom cover and disconnect the battery power cable.
3. Remove the following components:
 - Battery

Removal

1. Disconnect the antenna cable(s).
2. Remove the tape, then remove the cable(s) from the cable guide(s).

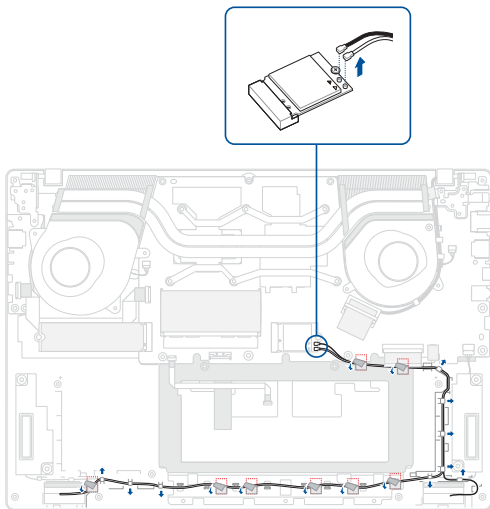

3. Disconnect the speaker connector.
4. Remove the speaker cable from the cable guide(s).
5. Remove the speakers.

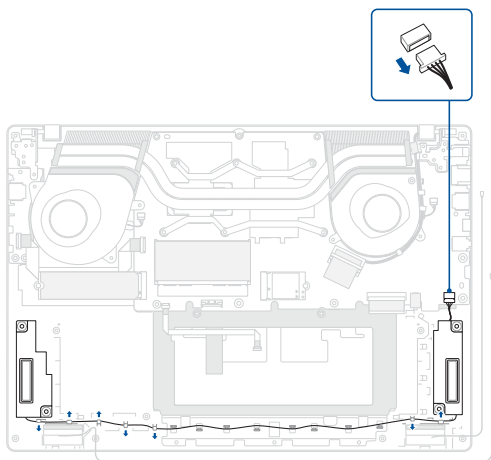

Installation

1. Install the speakers.
2. Route the speaker cable through the cable guide(s).

IMPORTANT! Damage may occur if cables are not properly routed through the cable guides. Confirm that all cables are routed through each of the indicated cable guides before proceeding.

3. Reconnect the speaker connector.

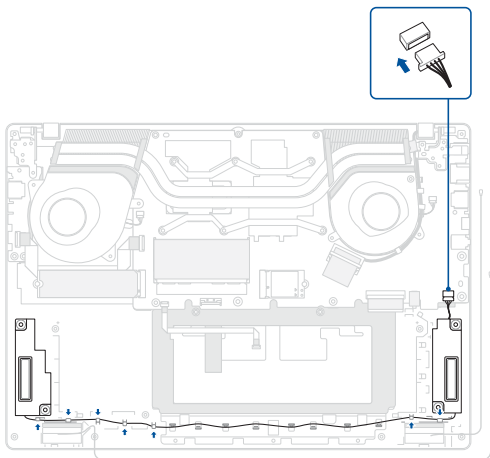

4. Route the antenna cable(s) through the cable guide(s) and reattach the tape.

IMPORTANT! Damage may occur if cables are not properly routed through the cable guides. Confirm that all cables are routed through each of the indicated cable guides before proceeding.

5. Reconnect the antenna cable(s).
6. Install the components you removed in the *Before you begin* section.

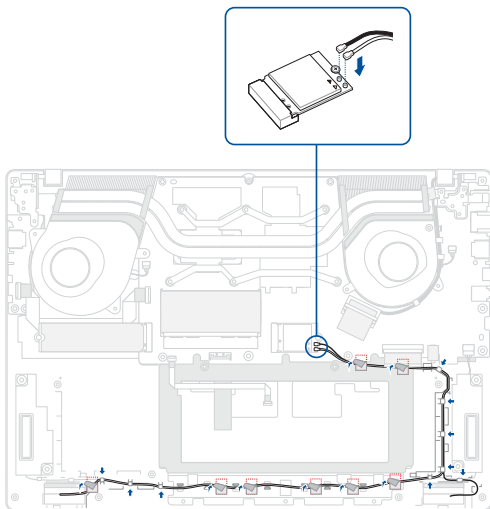

Fan module

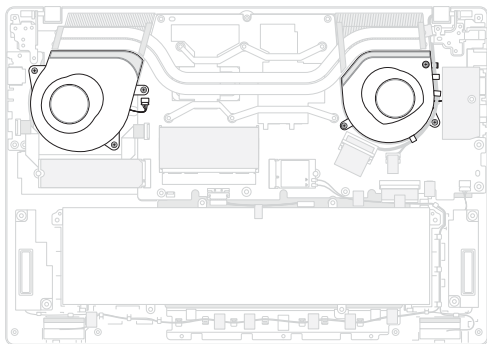

Before you begin

1. Read the **Safety Precautions** and **Pre-repair Checklist**.
2. Remove the bottom cover and disconnect the battery power cable.

Screw list

- ⊕ M2.0 X 4.0L (6pcs)

Removal

1. Disconnect the cable(s), then remove the cable(s) from the cable guide(s).

FHD camera model

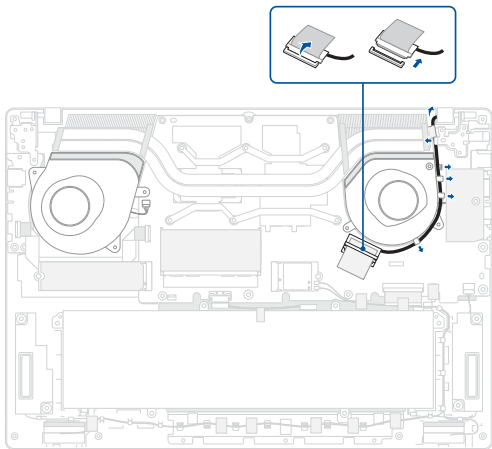

IR camera model

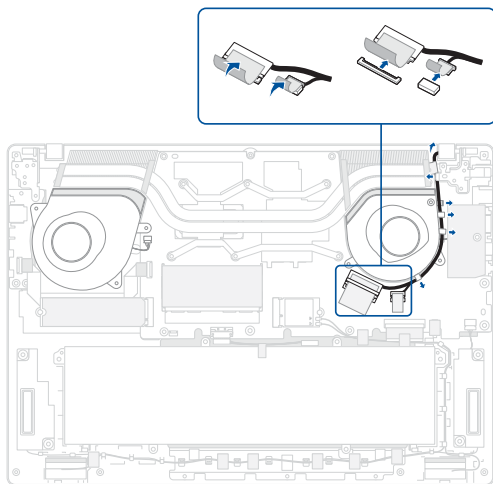

2. Remove the absorber sheet, then disconnect the fan connector(s).
3. Remove the screw(s).
4. Remove the fan(s).

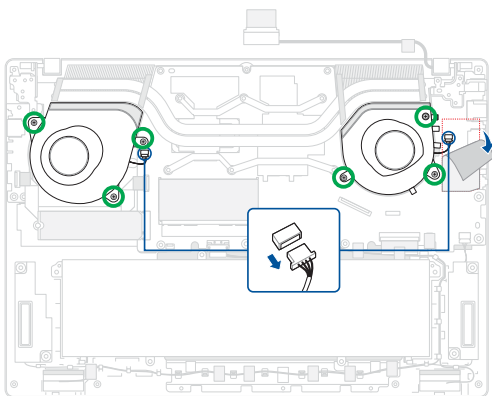

Installation

1. Install the fan(s).
2. Secure the fan(s) using the screw(s) you removed earlier.
3. Reconnect the fan connector(s), then reattach the absorber sheet.

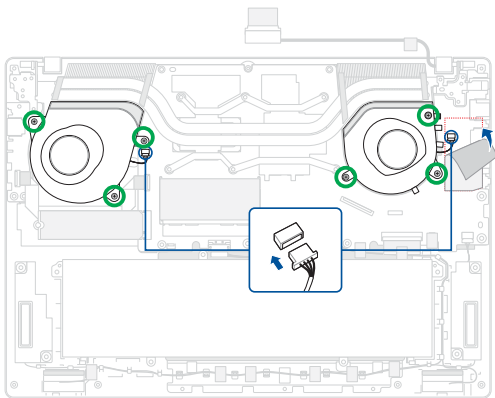

4. Route the cable(s) through the cable guide(s), then reconnect the cable(s).

IMPORTANT! Damage may occur if cables are not properly routed through the cable guides. Confirm that all cables are routed through each of the indicated cable guides before proceeding.

5. Install the components you removed in the *Before you begin* section.

FHD camera model

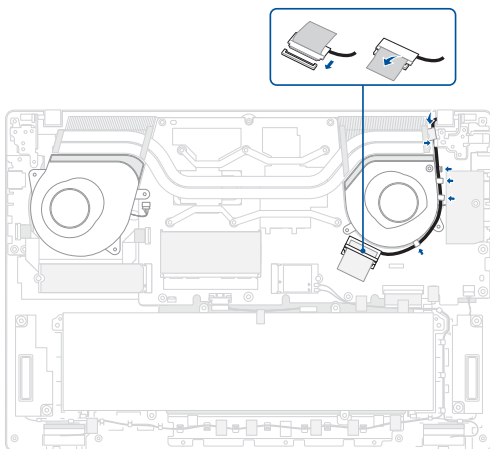

IR camera model

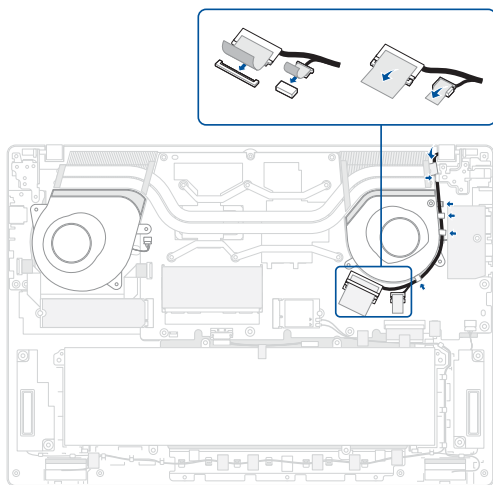

Heat sink and motherboard

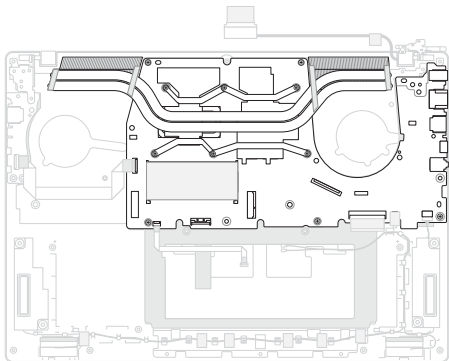

Before you begin

IMPORTANT! Thermal paste, thermal pads, liquid metal, or other thermal interface materials must be thoroughly removed and replaced if this component is removed. Ensure that replacement materials are available before proceeding, or contact an authorized service center for assistance.

1. Read the **Safety Precautions** and **Pre-repair Checklist**.

2. Remove the bottom cover and disconnect the battery power cable.
3. Remove the following components:
 - Battery
 - M.2 SSD module
 - RAM module
 - WLAN module
 - Fan module

Screw list

- ⊕ M2.0 X 4.0L (10pcs)
- ⊕ M2.0 X 3.0L (5pcs)

Removal

1. Remove the tape from the antenna cable(s).

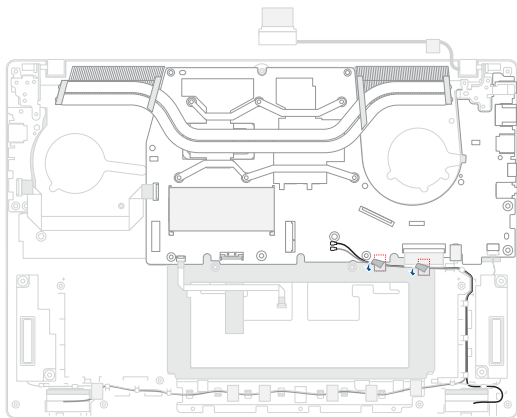

2. Remove and disconnect the cable(s) as shown in the illustration below.

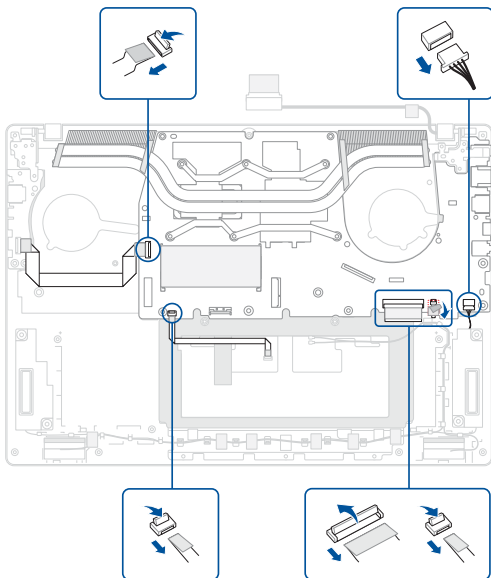

3. Remove the screw(s) from the hinge on the right side, then lift the hinge to a 90-degree position.

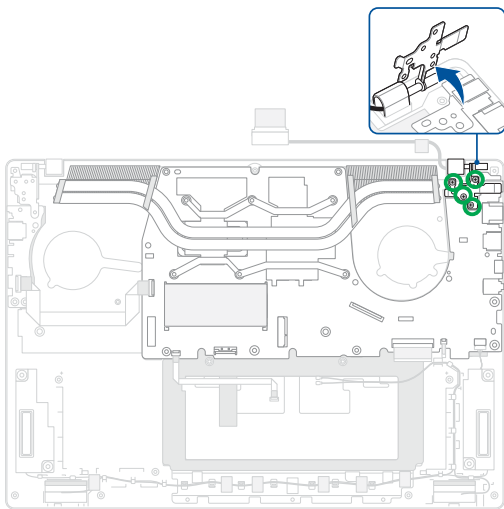

4. Remove the screw(s), then remove the motherboard with heat sink attached.

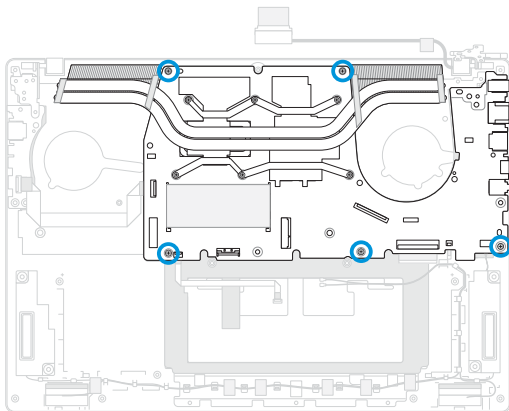

- Remove the heat sink screw(s) one by one in the sequence shown in the illustration below, then remove the heat sink from the motherboard.

IMPORTANT! Vertically lift the heat sink using the left side of the heat sink to prevent damage.

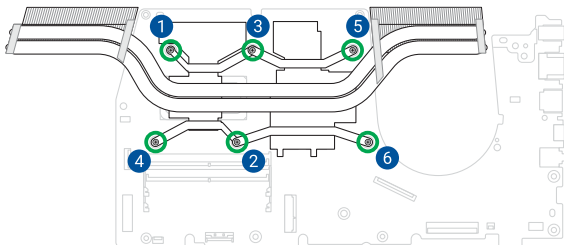

Installation

1. Install the heat sink, then secure the heat sink screw(s) one by one in the sequence shown in the illustration below.

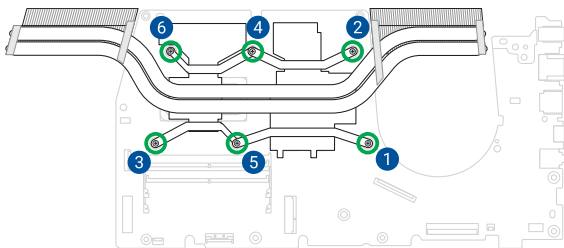

2. Install the motherboard with heat sink attached, then secure the motherboard and heat sink using the screw(s) you removed earlier.

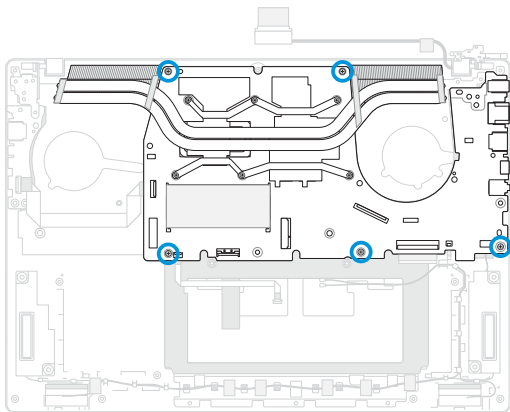

3. Place the hinge of the display panel module on the screw holes, then secure the hinge using the screw(s) you removed earlier.

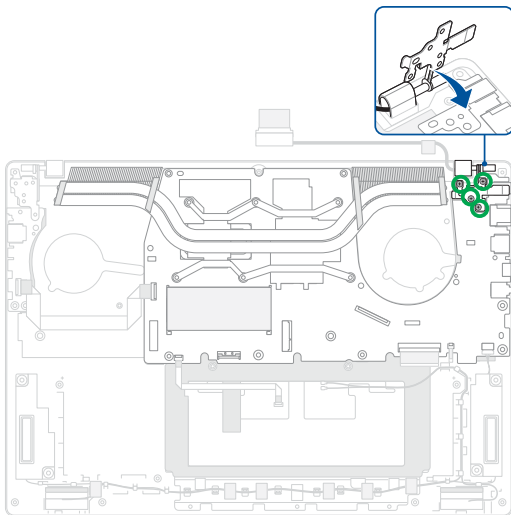

4. Reconnect the cable(s), then reattach the tape.

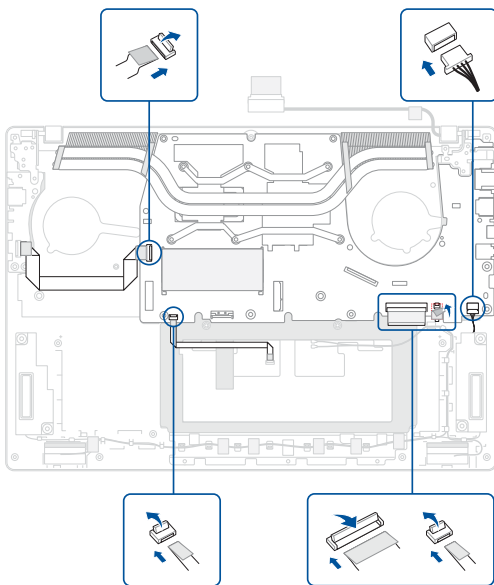

5. Route the antenna cable(s) as shown in the illustration below and reattach the tape.
6. Install the components you removed in the *Before you begin* section.

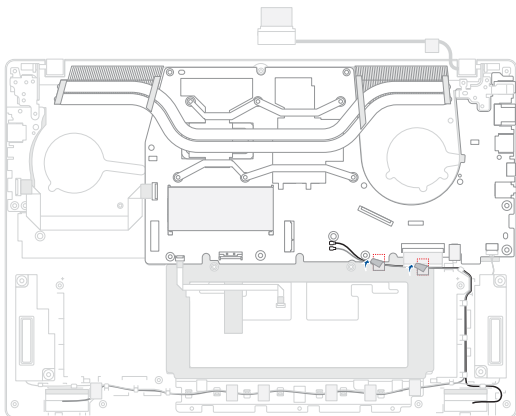

I/O board

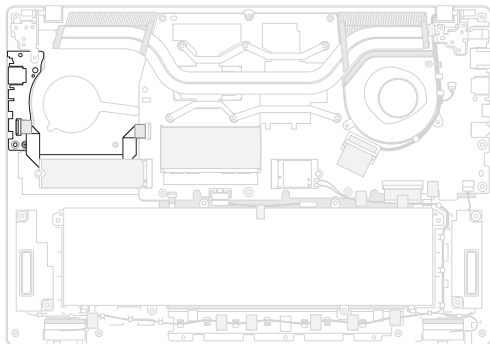

Before you begin

1. Read the **Safety Precautions** and **Pre-repair Checklist**.
2. Remove the bottom cover and disconnect the battery power cable.

Screw list

- ⊕ M2.0 X 4.0L (7pcs)
- ⊕ M2.0 X 3.0L (1pc)

Removal

1. Disconnect the fan connector.
2. Remove the screw(s), then remove the fan.

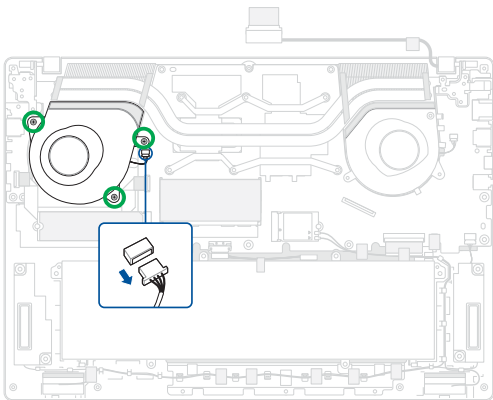

3. Disconnect the I/O board cable.

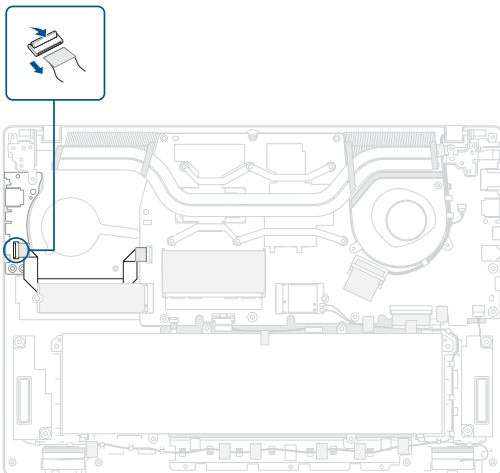

4. Remove the screw(s) from the hinge on the left side, then lift the hinge to a 90-degree position.

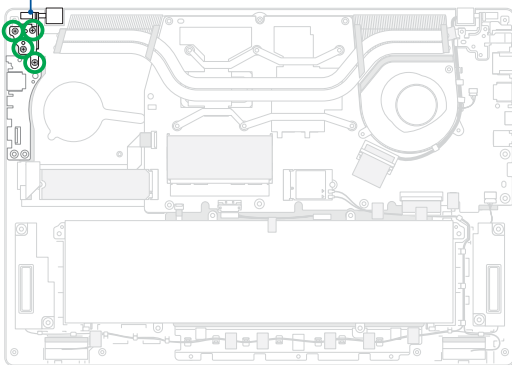
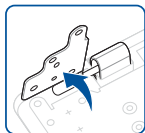

5. Remove the screw, then remove the I/O board.

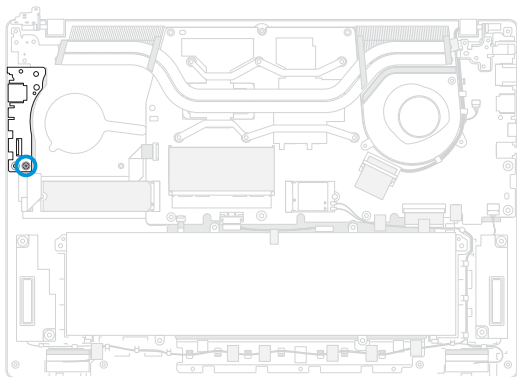

Installation

1. Install the I/O board, then secure the I/O board using the screw you removed earlier.

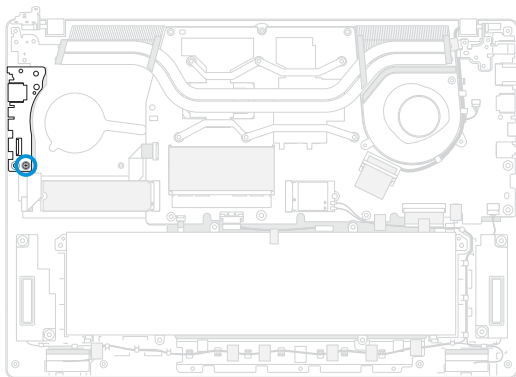

2. Place the hinge of the display panel module on the screw holes, then secure the hinge using the screw(s) you removed earlier.

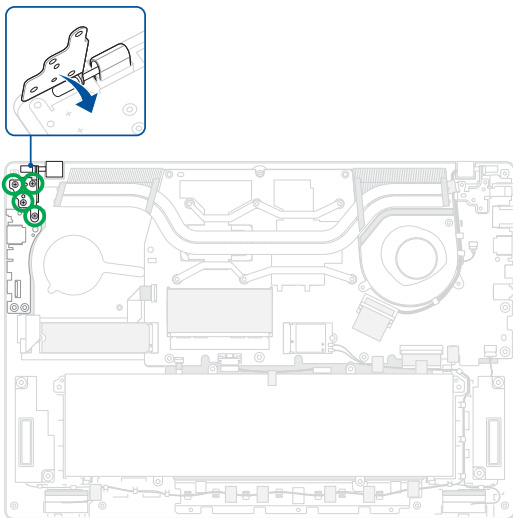

3. Reconnect the I/O board cable.

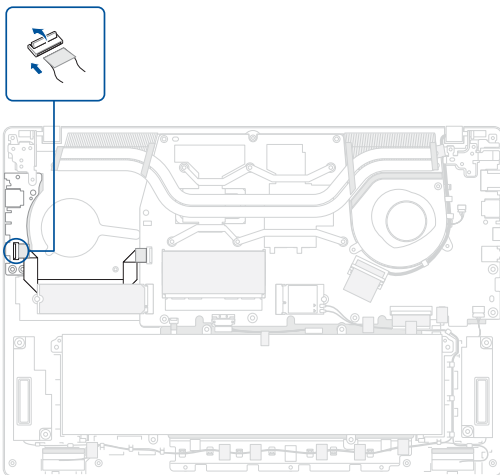

4. Install the fan, then secure the fan using the screw(s) you removed earlier.
5. Reconnect the fan connector.
6. Install the components you removed in the *Before you begin* section.

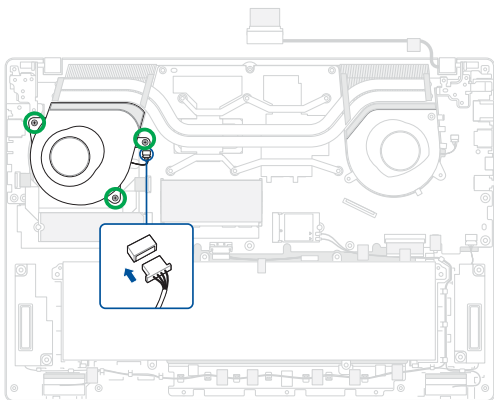

Touchpad

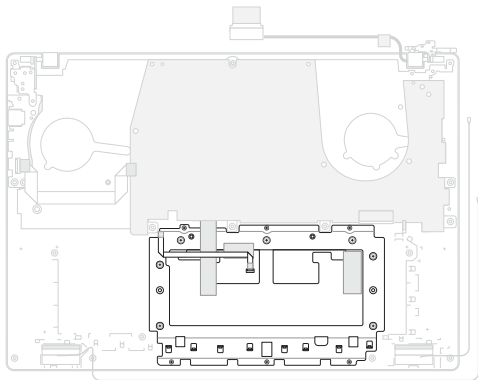

Before you begin

1. Read the **Safety Precautions** and **Pre-repair Checklist**.
2. Remove the bottom cover and disconnect the battery power cable.
3. Remove the following components:
 - Battery
 - M.2 SSD module
 - Speakers
 - Fan module
 - Heat sink and motherboard

Screw list

- ⊕ M2.0 X 3.0L (6pcs)
- ⊕ M2.0 X 2.0L (7pcs)

Removal

1. Disconnect the cable.

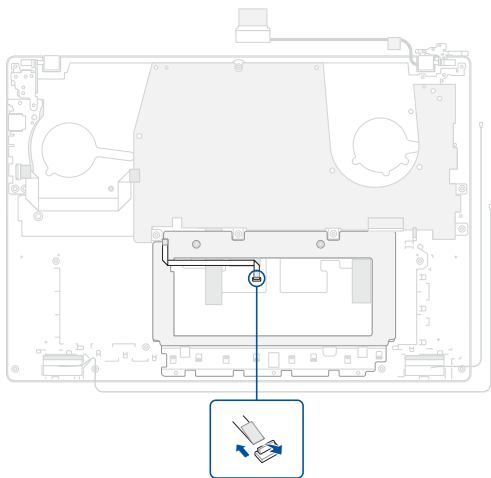

2. Partially peel off the polyester film as shown in the illustration below.

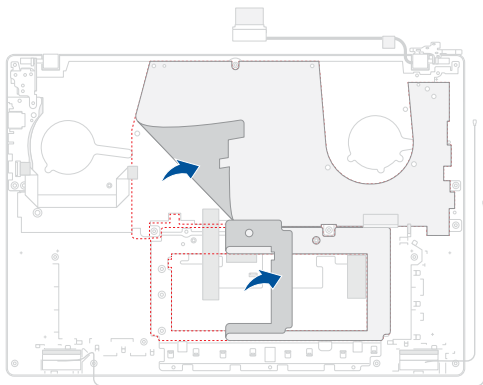

3. Remove the tape and sponge.
4. Remove the screw(s), then remove the touchpad module.

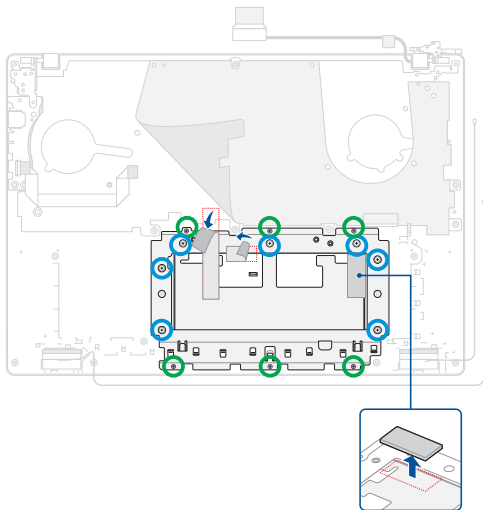

5. Remove the touchpad from the bracket as shown in the illustration below.

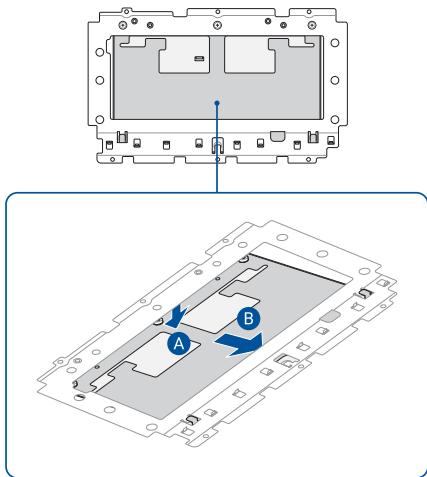

Installation

1. Align and install the touchpad to the bracket.

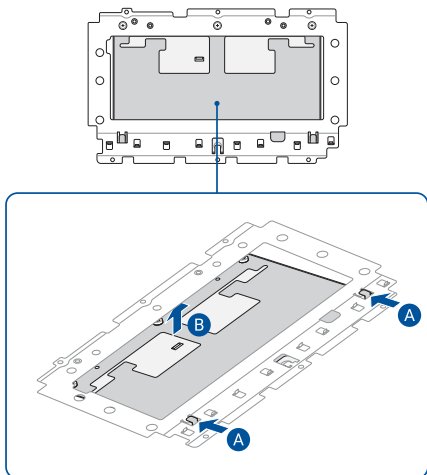

2. Install the touchpad module, then secure the touchpad module using the screw(s) you removed earlier.
3. Reattach the tape and sponge.

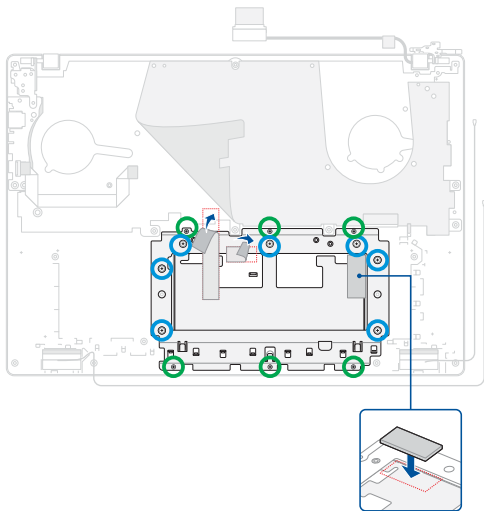

4. Reattach the polyester film.

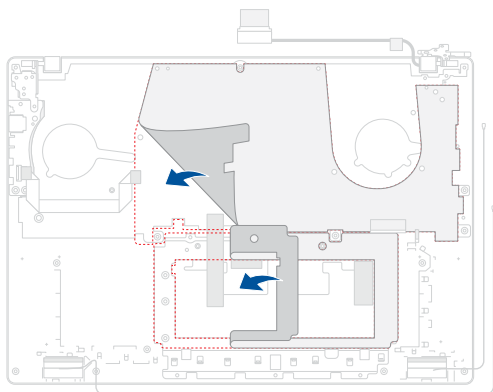

5. Reconnect the cable to the touchpad.
6. Install the components you removed in the *Before you begin* section.

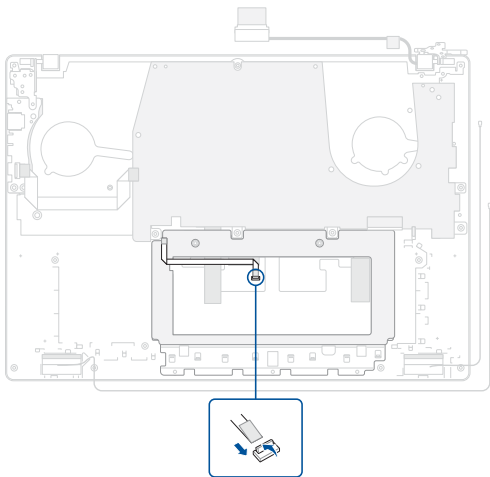

Display panel module

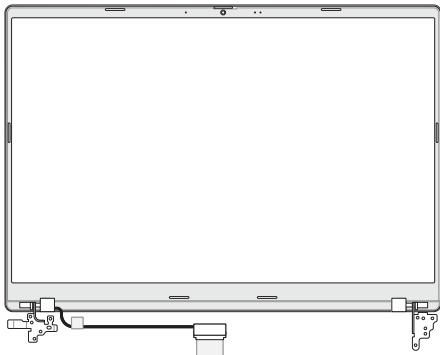

Before you begin

IMPORTANT! Do not bend the display panel in any way to avoid risk of display panel leakage.

1. Read the **Safety Precautions** and **Pre-repair Checklist**.
2. Remove the bottom cover and disconnect the battery power cable.

Screw list

- ⊕ M2.0 X 4.0L (8pcs)

Removal

1. Place your device with the display panel hanging over the edge of the workspace as shown in the illustration below.

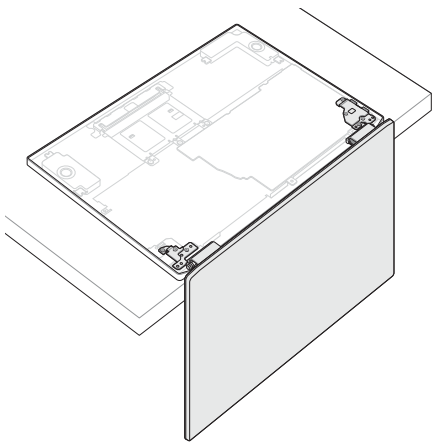

2. Disconnect the cable(s), then remove the cable(s) from the cable guide(s).

FHD camera model

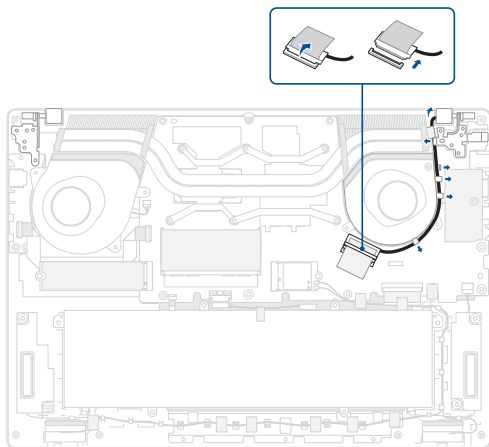

IR camera model

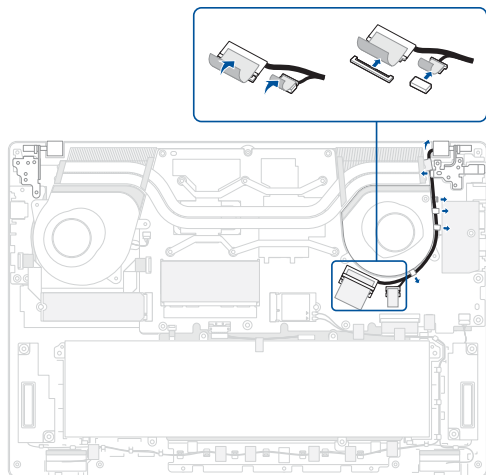

3. Remove the screw(s).

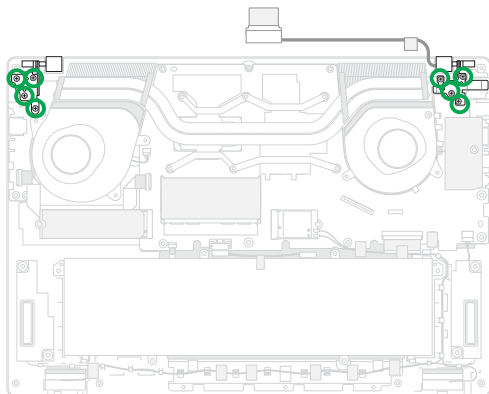

4. Remove the display panel module.

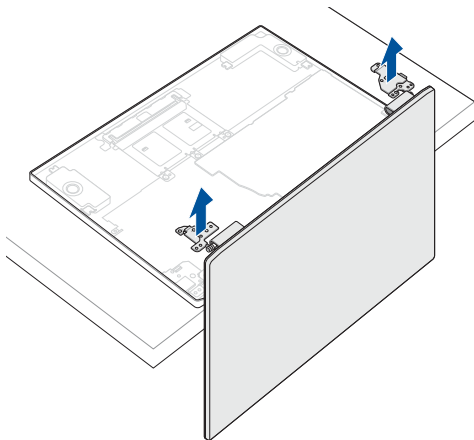

Installation

1. In the orientation shown, align and place the hinges of the display panel module on the screw holes.

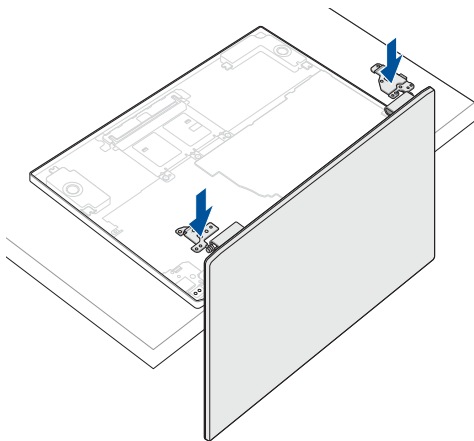

2. Secure the hinges using the screw(s) you removed earlier.

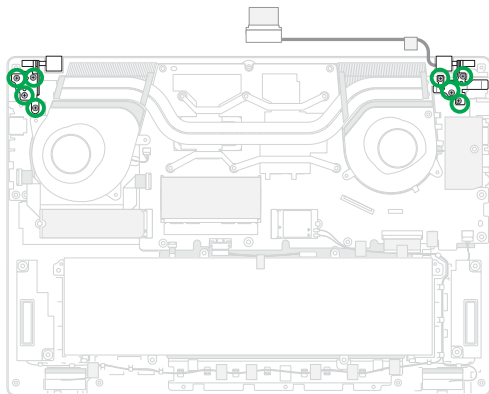

3. Route the cable(s) through the cable guide(s), then reconnect the cable(s).

IMPORTANT! Damage may occur if cables are not properly routed through the cable guides. Confirm that all cables are routed through each of the indicated cable guides before proceeding.

4. Install the components you removed in the *Before you begin* section.

FHD camera model

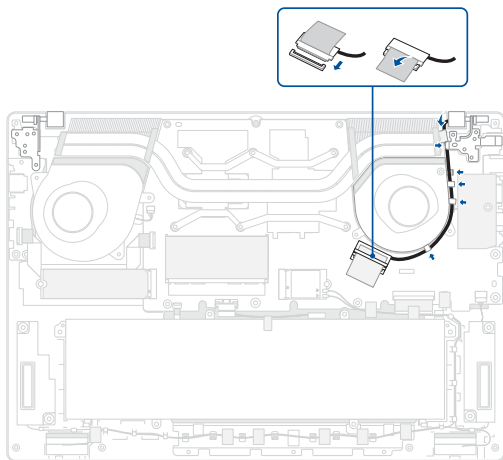

IR camera model

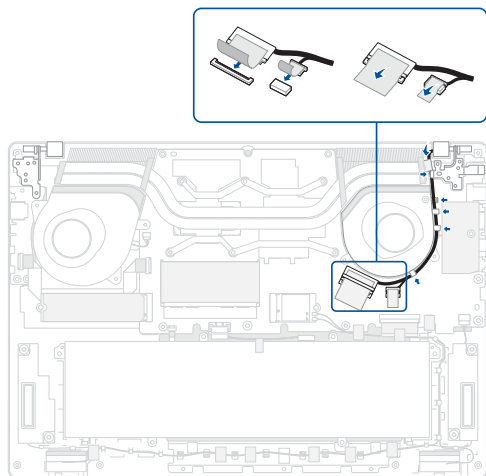

Display bezel

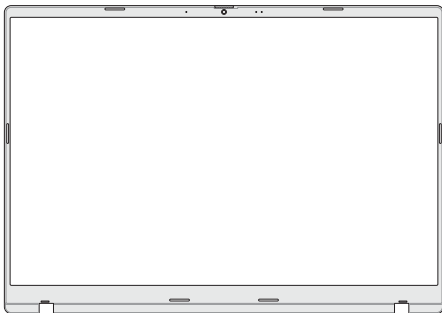

Before you begin

IMPORTANT! This component is fragile. Damage may occur if the service procedure is performed incorrectly. If you are uncertain about proceeding, stop and contact an authorized service center for assistance.

1. Read the **Safety Precautions** and **Pre-repair Checklist**.
2. Remove the bottom cover and disconnect the battery power cable.
3. Remove the following components:
 - Display panel module

Removal

1. Push the hinge caps in the orientation as shown to remove them.

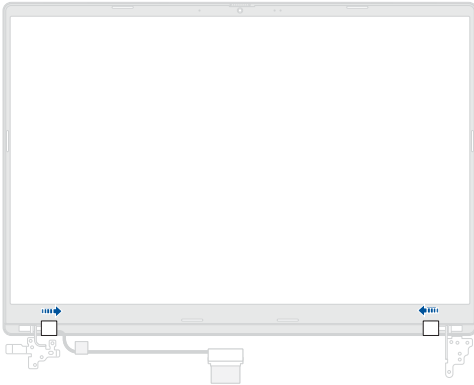

2. Carefully pry the bezel loose, then remove the bezel.

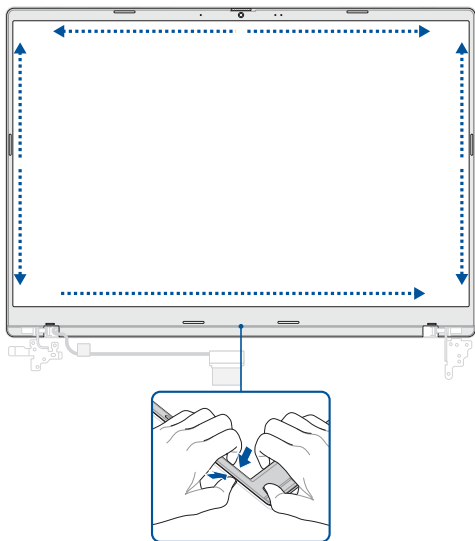

Installation

1. Remove the release liner(s) from the tape on the bezel.

NOTE: The tape cannot be reused. Remove any adhesive residue and use new tape when reinstalling components.

2. Align and install the bezel.

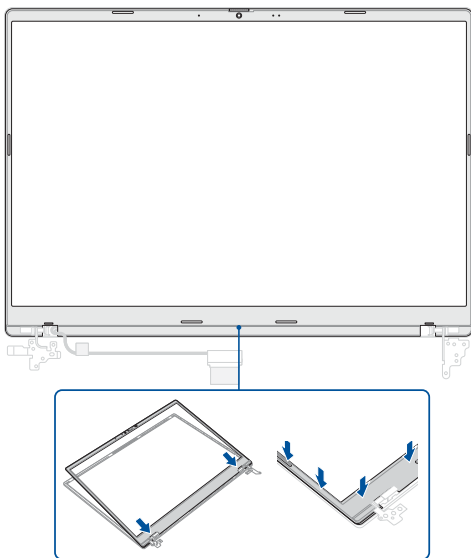

3. Align and install the hinge caps in the proper orientation as shown and ensure that the hinge caps are securely installed.
4. Install the components you removed in the *Before you begin* section.

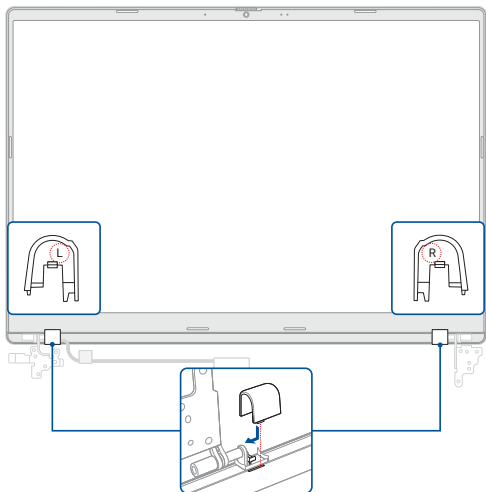

Display hinges



Before you begin

1. Read the **Safety Precautions** and **Pre-repair Checklist**.
2. Remove the bottom cover and disconnect the battery power cable.
3. Remove the following components:
 - Display panel module
 - Display bezel

Screw list

- ⊕ M2.5 X 3.0L (8pcs)

Removal

Remove the screw(s), then remove the hinges.

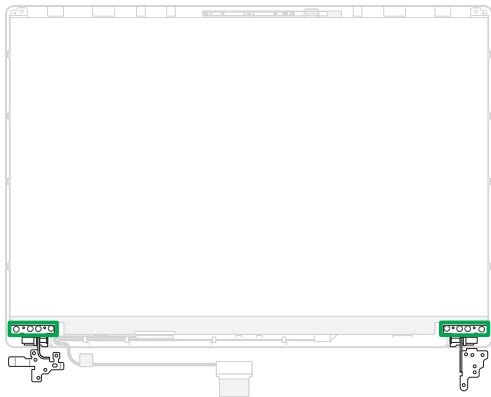

Installation

1. Install the hinges, then secure the hinges using the screw(s) you removed earlier.
2. Install the components you removed in the *Before you begin* section.

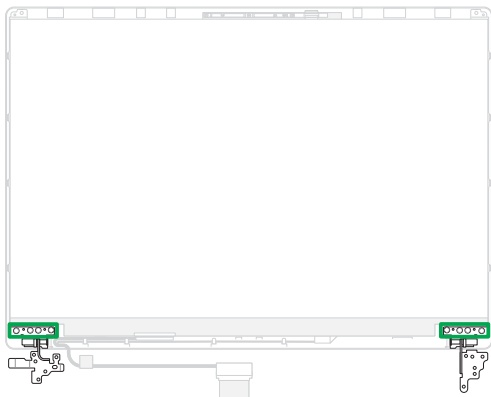

Display panel

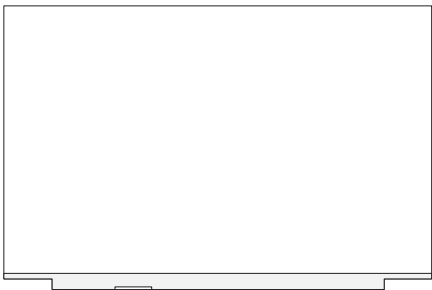

Before you begin

IMPORTANT!

- This component is fragile. Damage may occur if the service procedure is performed incorrectly. If you are uncertain about proceeding, stop and contact an authorized service center for assistance.
 - Do not bend the display panel in any way to avoid risk of display panel leakage.
-

1. Read the **Safety Precautions** and **Pre-repair Checklist**.
2. Remove the bottom cover and disconnect the battery power cable.
3. Remove the following components:
 - Display panel module
 - Display bezel
 - Display hinges

Screw list

- ⊕ M2.0 X 2.0L (2pcs)

Removal

1. Remove the screw(s).
2. Gently push the indicated hooks outwards on both sides of the top cover to remove the display panel.

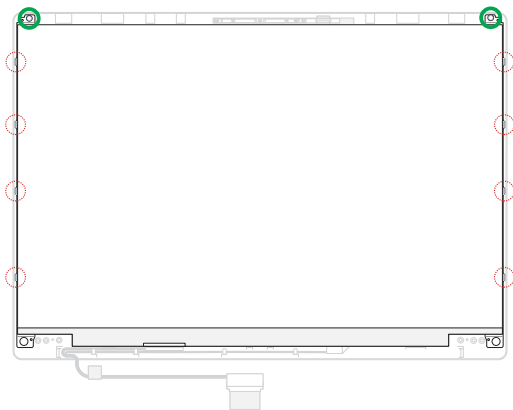

3. Lift the display panel, then disconnect the cable from the rear side of the display panel.

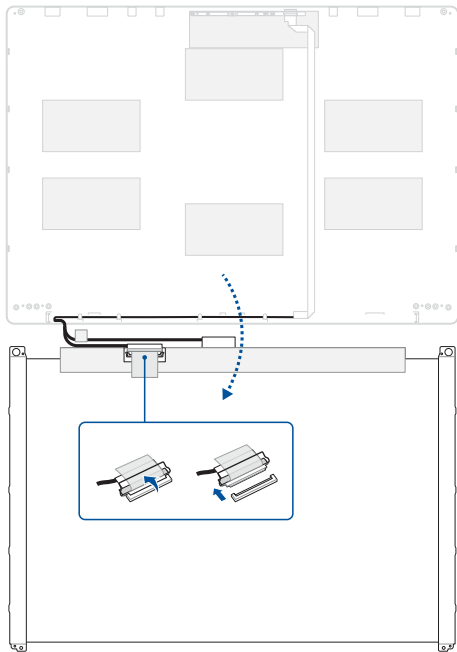

Installation

1. Place the top cover in the orientation shown in the illustration below.
2. Align and install the display brackets on the top cover, then secure the brackets using the screw(s) you removed earlier.

IMPORTANT! The display brackets are not removable and cannot be reused. Ensure that the display brackets are oriented correctly before installation.

3. Remove the release liner(s) from the tape on the display brackets

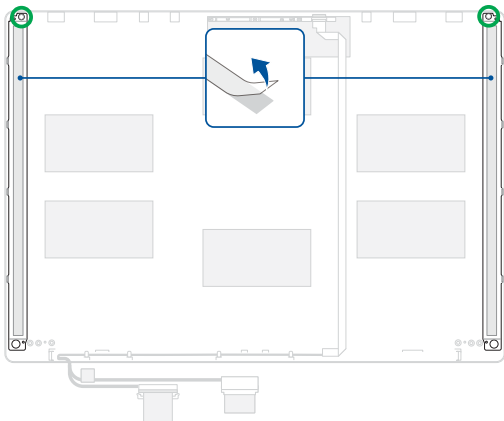

4. Reconnect the cable to the rear side of the display panel.
5. Align and install the display panel.
6. Install the components you removed in the *Before you begin* section.

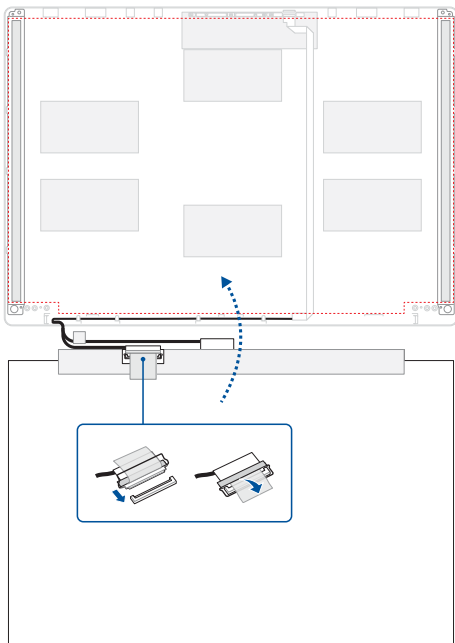

Camera module

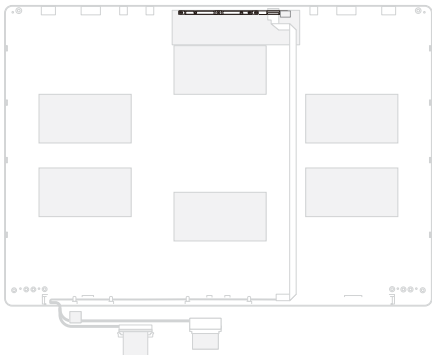

Before you begin

IMPORTANT! This component is fragile. Damage may occur if the service procedure is performed incorrectly. If you are uncertain about proceeding, stop and contact an authorized service center for assistance.

1. Read the **Safety Precautions** and **Pre-repair Checklist**.
2. Remove the bottom cover and disconnect the battery power cable.
3. Remove the following components:
 - Display panel module
 - Display bezel
 - Display hinges
 - Display panel

Removal

FHD camera model

1. Remove the tape from the camera module.
2. Carefully pry up the camera module and disconnect the cable, then remove the rubber caps from the camera module.

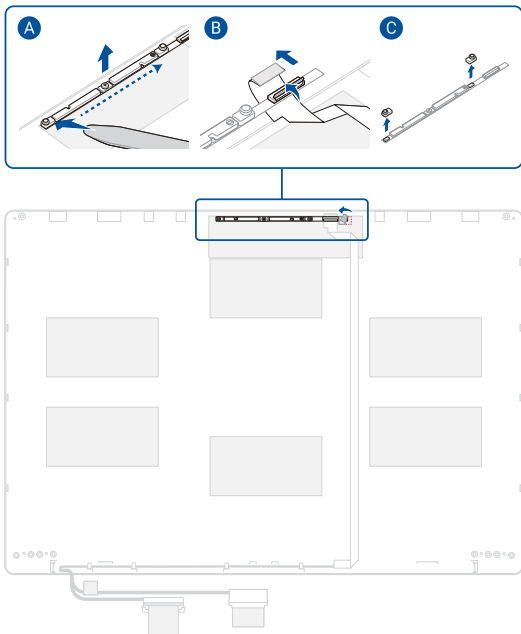

IR camera model

Disconnect the cable and carefully pry up the camera module, then remove the rubber caps from the camera module.

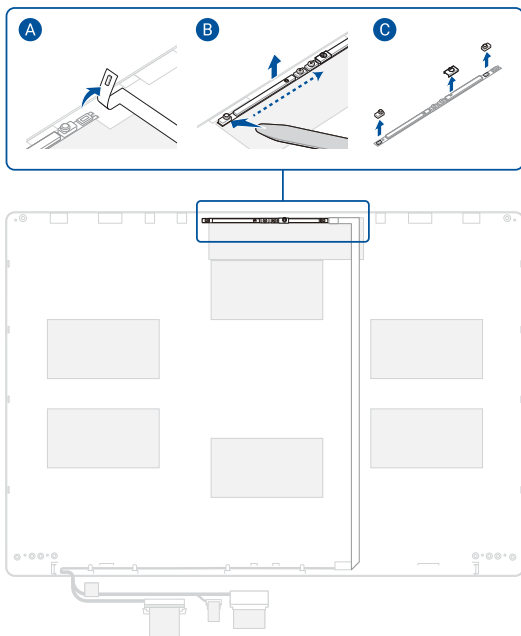

Installation

FHD camera model

1. Attach the rubber caps to the camera module and reconnect the cable, then install the camera module.
2. Reattach the tape.
3. Install the components you removed in the *Before you begin* section.

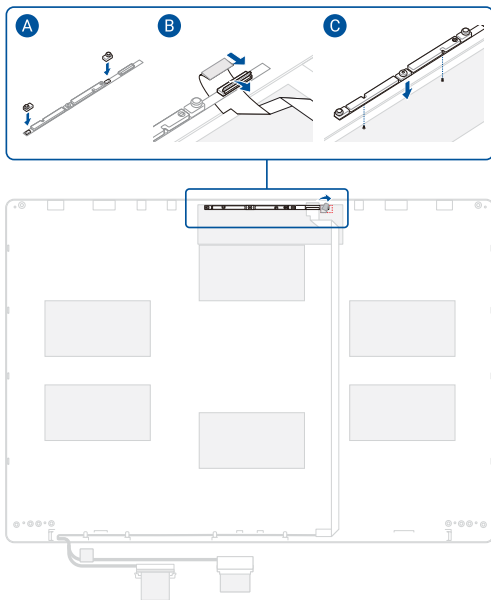

IR camera model

1. Attach the rubber caps to the camera module, then install the camera module and reconnect the cable to the camera module.
2. Install the components you removed in the *Before you begin* section.

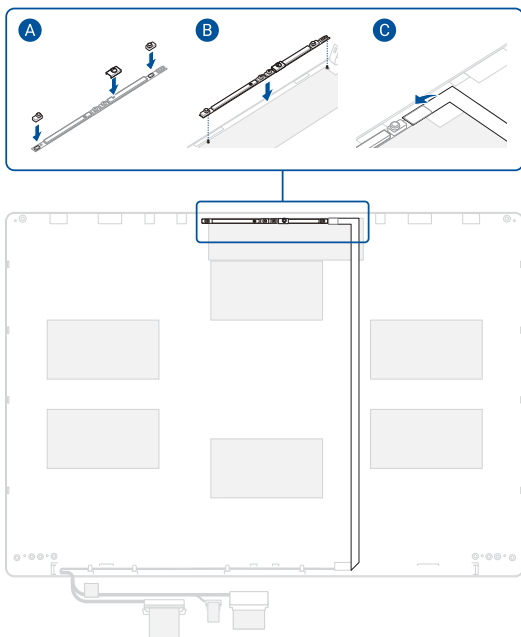

Top cover

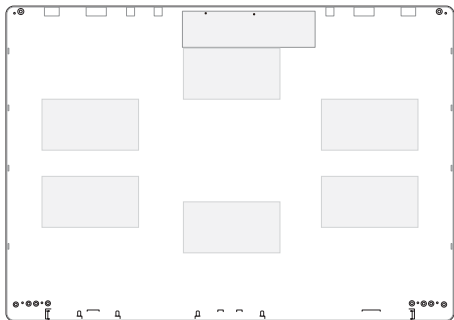

Before you begin

1. Read the **Safety Precautions** and **Pre-repair Checklist**.
2. Remove the bottom cover and disconnect the battery power cable.
3. Remove the following components:
 - Display panel module
 - Display bezel
 - Display hinges
 - Display panel
 - Camera module

Removal

Remove the cable as shown in the illustration below.

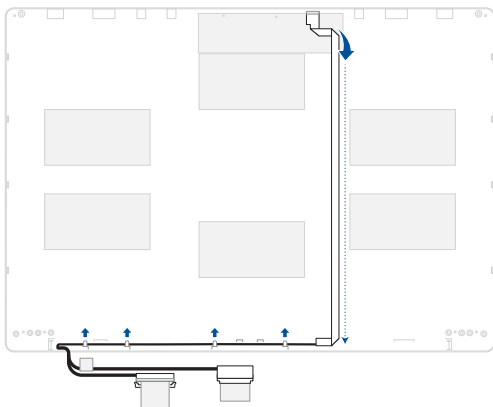

Installation

1. Install the cable and route the cable through the cable guide(s).

IMPORTANT! Damage may occur if cables are not properly routed through the cable guides. Confirm that all cables are routed through each of the indicated cable guides before proceeding.

2. Install the components you removed in the *Before you begin* section.

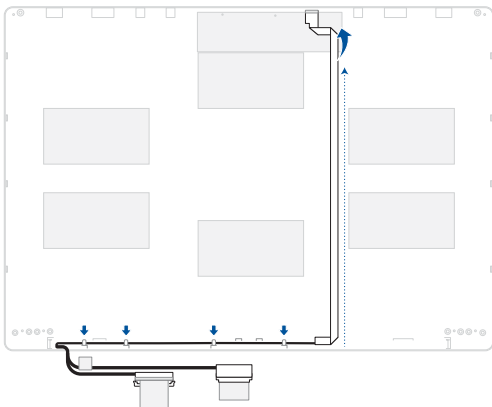

Keyboard module

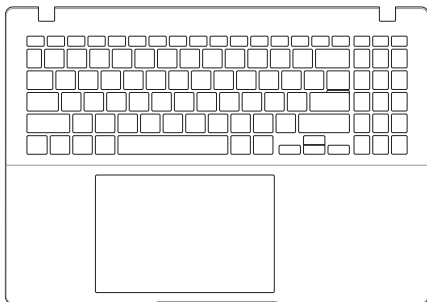

Before you begin

1. Read the **Safety Precautions** and **Pre-repair Checklist**.
2. Remove the bottom cover and disconnect the battery power cable.
3. Remove the following components:
 - Battery
 - M.2 SSD module
 - Speakers
 - Fan module
 - Heat sink and motherboard
 - I/O board
 - Touchpad
 - Display panel module

Screw list

- ⊕ M2.0 X 3.0L (1pc)

Removal

1. Remove the I/O board cable.
2. Remove the antenna cable(s) as shown in the illustration below.

IMPORTANT! The antenna cable(s) cannot be reused once removed.

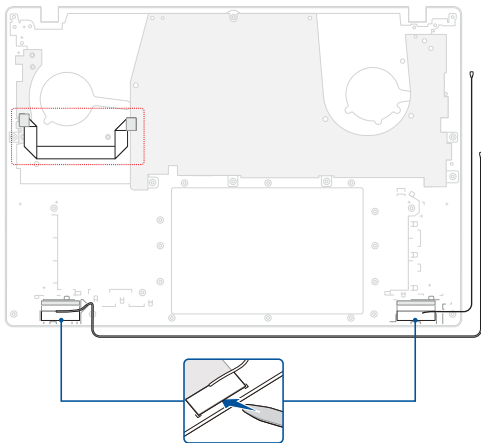

Installation

1. Install the I/O board, then secure the I/O board using the screw you removed earlier.

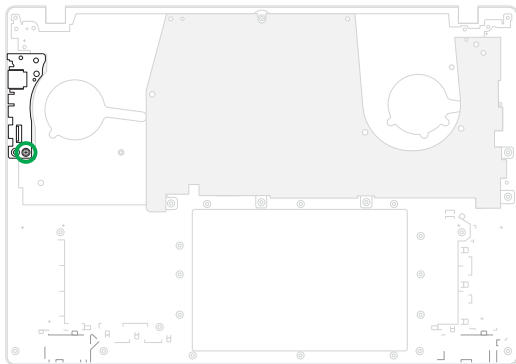

2. Install and reconnect the I/O board cable.
3. Install the antenna cable(s), then route the cable(s) through the cable guide(s).

IMPORTANT! Damage may occur if cables are not properly routed through the cable guides. Confirm that all cables are routed through each of the indicated cable guides before proceeding.

4. Install the components you removed in the *Before you begin* section.

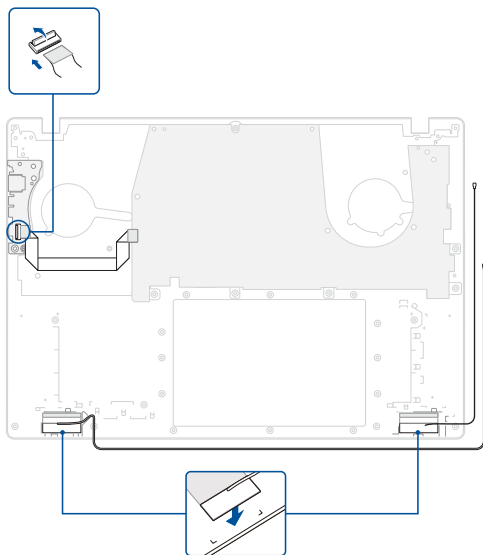

Appendices

Wiring and connection diagrams

Top View

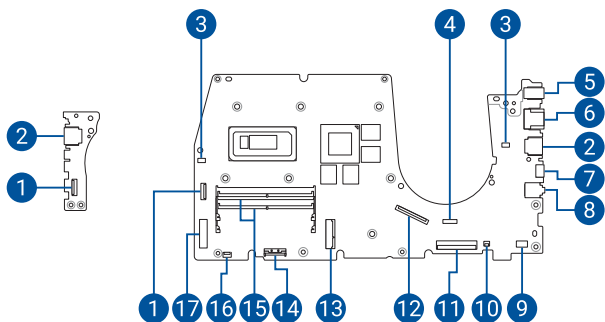

Bottom View

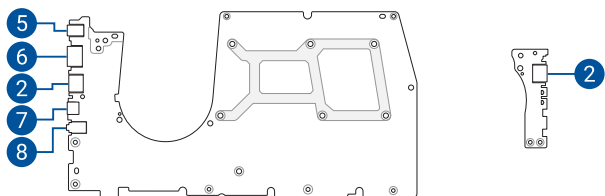

1. I/O board connector
2. USB Type-A connector
3. Fan connector
4. IR camera connector
5. Power supply connector
6. HDMI connector
7. USB Type-C® connector
8. Audio connector
9. Speaker connector
10. Keyboard backlight connector
11. Keyboard connector
12. eDP/camera connector
13. WLAN connector
14. Battery connector
15. RAM module slot
16. Touchpad connector
17. M.2 SSD connector

