

E24206

First Edition / May 2025



ROG STRIX

GAMING NOTEBOOK PC

SERVICE MANUAL

MORE INFO:



COPYRIGHT INFORMATION

No part of this manual, including the products and software described in it, may be reproduced, transmitted, transcribed, stored in a retrieval system, or translated into any language in any form or by any means, except documentation kept by the purchaser for backup purposes, without the express written permission of ASUSTeK COMPUTER INC. ("ASUS").

ASUS PROVIDES THIS MANUAL "AS IS" WITHOUT WARRANTY OF ANY KIND, EITHER EXPRESS OR IMPLIED, INCLUDING BUT NOT LIMITED TO THE IMPLIED WARRANTIES OR CONDITIONS OF MERCHANTABILITY OR FITNESS FOR A PARTICULAR PURPOSE. IN NO EVENT SHALL ASUS, ITS DIRECTORS, OFFICERS, EMPLOYEES OR AGENTS BE LIABLE FOR ANY INDIRECT, SPECIAL, INCIDENTAL, OR CONSEQUENTIAL DAMAGES (INCLUDING DAMAGES FOR LOSS OF PROFITS, LOSS OF BUSINESS, LOSS OF USE OR DATA, INTERRUPTION OF BUSINESS AND THE LIKE), EVEN IF ASUS HAS BEEN ADVISED OF THE POSSIBILITY OF SUCH DAMAGES ARISING FROM ANY DEFECT OR ERROR IN THIS MANUAL OR PRODUCT.

Products and corporate names appearing in this manual may or may not be registered trademarks or copyrights of their respective companies, and are used only for identification or explanation and to the owners' benefit, without intent to infringe.

SPECIFICATIONS AND INFORMATION CONTAINED IN THIS MANUAL ARE FURNISHED FOR INFORMATIONAL USE ONLY, AND ARE SUBJECT TO CHANGE AT ANY TIME WITHOUT NOTICE, AND SHOULD NOT BE CONSTRUED AS A COMMITMENT BY ASUS. ASUS ASSUMES NO RESPONSIBILITY OR LIABILITY FOR ANY ERRORS OR INACCURACIES THAT MAY APPEAR IN THIS MANUAL, INCLUDING THE PRODUCTS AND SOFTWARE DESCRIBED IN IT.

Copyright © 2025 ASUSTeK COMPUTER INC. All Rights Reserved.

LIMITATION OF LIABILITY

Circumstances may arise where because of a default on ASUS' part or other liability, you are entitled to recover damages from ASUS. In each such instance, regardless of the basis on which you are entitled to claim damages from ASUS, ASUS is liable for no more than damages for bodily injury (including death) and damage to real property and tangible personal property; or any other actual and direct damages resulted from omission or failure of performing legal duties under this Warranty Statement, up to the listed contract price of each product.

ASUS will only be responsible for or indemnify you for loss, damages or claims based in contract, tort or infringement under this Warranty Statement.

This limit also applies to ASUS' suppliers and its reseller. It is the maximum for which ASUS, its suppliers, and your reseller are collectively responsible.

UNDER NO CIRCUMSTANCES IS ASUS LIABLE FOR ANY OF THE FOLLOWING: (1) THIRD-PARTY CLAIMS AGAINST YOU FOR DAMAGES; (2) LOSS OF, OR DAMAGE TO, YOUR RECORDS OR DATA; OR (3) SPECIAL, INCIDENTAL, OR INDIRECT DAMAGES OR FOR ANY ECONOMIC CONSEQUENTIAL DAMAGES (INCLUDING LOST PROFITS OR SAVINGS), EVEN IF ASUS, ITS SUPPLIERS OR YOUR RESELLER IS INFORMED OF THEIR POSSIBILITY.

SERVICE AND SUPPORT

Visit our multi-language website at <https://www.asus.com/support/>

Table of Contents

Chapter 1: Introduction

Disclaimer	8
Safety precautions.....	8
Pre-repair checklist.....	10
Repair tools.....	11
Diagnostic tools.....	11
Major components	12

Chapter 2: Service Procedures

Bottom cover	16
Removal.....	17
Installation.....	19
M.2 SSD module	20
Removal.....	21
Installation.....	23
RAM module	25
Removal.....	26
Installation.....	28
Compartment cover	30
Removal.....	31
Installation.....	34
WLAN module.....	37
Removal.....	38
Installation.....	39
Woofer speakers.....	40
Removal.....	41
Installation.....	42

I/O board	43
Removal	44
Installation	48
Fan module	52
Removal	53
Installation	56
Battery	59
Removal	60
Installation	63
Vapor chamber heat sink and motherboard	66
Removal	68
Installation	70
Tweeter speakers (on selected models)	72
Removal	73
Installation	78
Display panel module	83
Removal	84
Installation	88
Touchpad	92
Removal	93
Installation	96
Antenna cable	99
Removal	101
Installation	102
Keyboard module	103
Removal	104
Installation	105
Display bezel	106
Removal	107
Installation	111

Display panel.....	113
Removal.....	114
Installation.....	117
eDP cable.....	120
Removal.....	121
Installation.....	122
Camera module.....	123
Removal.....	124
Installation.....	125
Logo backlight module (on selected models).....	126
Removal.....	127
Installation.....	129
Camera cable.....	131
Removal.....	132
Installation.....	133
Appendices	
Wiring and connection diagrams.....	136

Chapter 1: ***Introduction***

Disclaimer

ASUS is not responsible for direct, indirect, intentional or unintentional damages resulting from improper installation and operation.

Safety precautions

- Before handling components, use a grounded wrist strap or touch a safely grounded object to avoid damaging them due to static electricity.
- Keep liquids or moisture away from your device to avoid short circuits.
- Remove rings, watches, and any other metal objects from your hands.
- Hold components by the edges to avoid touching the ICs.
- Properly install all components before connecting the AC power.
- Do not use power adapters or batteries from other devices to reduce the risk of injury to persons due to fire or explosion. Use only certified power adapters or batteries supplied by the manufacturer or authorized retailers.
- Detach all clips or flaps before removing cables to prevent damage.

- Disconnect cables, connectors, and power plugs by pulling the plug evenly to avoid damage.
- Use the correct screw models on your device to prevent damage.
- Confirm that the cable orientation is correct before connecting any cables.
- Fully remove all adhesive residue after removing and before installing any components.
- Photograph the appearance of cables, cable routing, connectors, and screws for later reference before proceeding with each step.

Pre-repair checklist

- Read the entire manual before starting any service procedures and follow all instructions.
 - Back up the data on your device.
 - Place your device on a clean and stable surface.
 - Turn off your device.
 - Disconnect all connected peripherals and cables.
 - Disconnect all power cables and remove the battery pack (if applicable).
-

IMPORTANT!

- If you are uncertain about performing the described service procedures, stop and contact an authorized service center for assistance.
 - Purchase replacement components from authorized retailers of this device to ensure maximum compatibility and reliability.
-

NOTE:

- The illustrations are for reference only.
 - The service procedures described in this manual depend on the model configuration and may not reflect the entire servicing process. To service components that are not covered in this manual, please visit an authorized service center for further assistance.
 - Keep all adhesive tape, insulating materials, screws, and other removable items in a safe place until the service procedure is completed, as they may be needed during installation.
-

Repair tools



Screwdriver



Plastic blade



Tweezers

Diagnostic tools

Use ASUS System Diagnostics after completing any service procedures to ensure that all components are working properly.

For more information, visit www.asus.com/support/FAQ/1048490/.

Major components

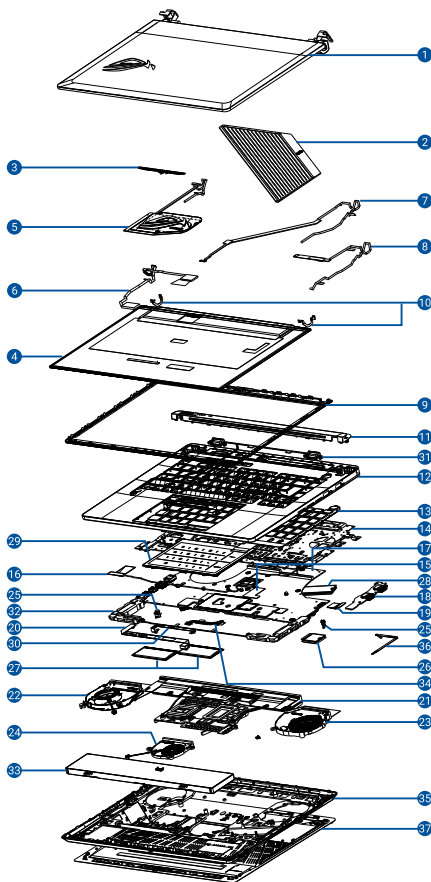

1. Top cover
2. Matrix*
3. Camera module
4. Display panel
5. Logo backlight module*
6. eDP cable
7. Camera cable
8. Matrix cable*
9. Display bezel
10. Hinge cap
11. Hinge cover
12. Keyboard frame
13. Keyboard module
14. Keyboard shielding
15. Antenna (right)
16. Antenna (left)
17. Motherboard
18. I/O board
19. I/O board cable
20. Keyboard backlight cable
21. Vapor chamber heat sink
22. CPU fan (left)
23. CPU fan (right)
24. VRAM fan
25. SSD latch
26. WLAN module
27. RAM module
28. M.2 SSD module
29. Touchpad module
30. Touchpad cable
31. Tweeter Speakers*
32. Woofer speakers
33. Battery
34. Battery cable
35. Compartment cover
36. Compartment cover cable
37. Bottom cover

** On selected models*

Chapter 2: ***Service Procedures***

Bottom cover



Before you begin

Read the **Safety Precautions** and complete the **Pre-repair Checklist**.

Removal

IMPORTANT! System power will be cut off automatically upon removal of the bottom cover. To restore power, reattach the bottom cover securely and connect the AC power adapter to your Notebook PC after the servicing is complete.

1. Push the slide lock to the left to release the bottom cover.



2. Ensure the bottom cover is unlocked, then use both hands to slide out the bottom cover until you hear a click.
3. Lift and remove the bottom cover.

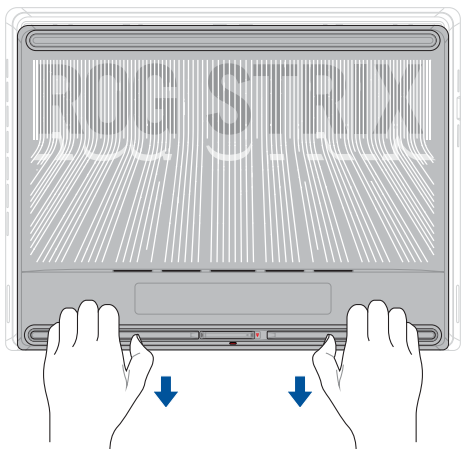

Installation

IMPORTANT! System power will be cut off automatically upon removal of the bottom cover. To restore power, reattach the bottom cover securely and connect the AC power adapter to your Notebook PC after the servicing is complete.

Align and slide the bottom cover back in place until you hear a click.



M.2 SSD module

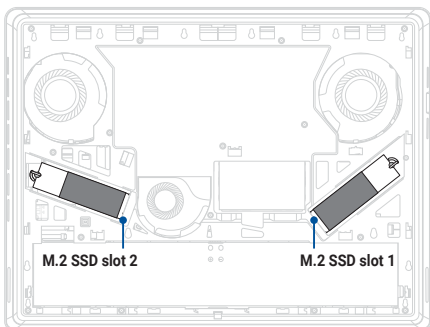

Before you begin

IMPORTANT! Thermal paste, thermal pads, liquid metal, or other thermal interface materials must be thoroughly removed and replaced if this component is removed. Ensure that replacement materials are available before proceeding, or contact an authorized service center for assistance.

NOTE: (For models G615JHR, G615JH, G615JMR, G615JM and G615JPR) The M.2 SSD slot 1 supports PCIe 5.0. Ensure your PCIe 5.0 M.2 SSD is installed in M.2 SSD slot 1 for optimal performance.

1. Read the **Safety Precautions** and **Pre-repair Checklist**.
2. Remove the bottom cover.

Removal

1. Partially peel off the polyester film as shown in the illustration below.

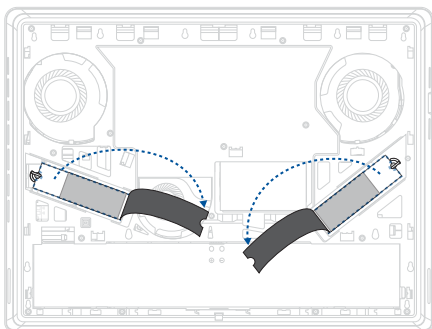

2. Turn the latch knob(s) counterclockwise to release the M.2 SSD module(s).
3. Remove the M.2 SSD module(s) from the motherboard, then remove the tape.

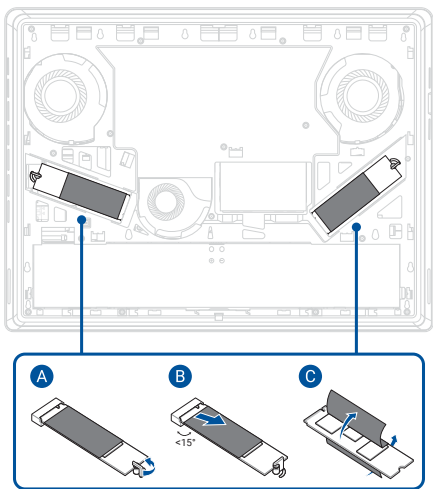

Installation

1. Reattach the tape, then align and insert the M.2 SSD module(s) into the M.2 connector(s).
2. Hold the M.2 SSD module(s) down, then turn the latch knob(s) clockwise to secure the M.2 SSD module(s).

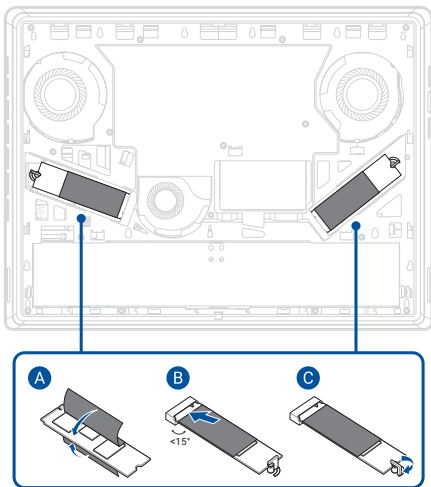

3. Reattach the polyester film.
4. Install the components you removed in the *Before you begin* section.

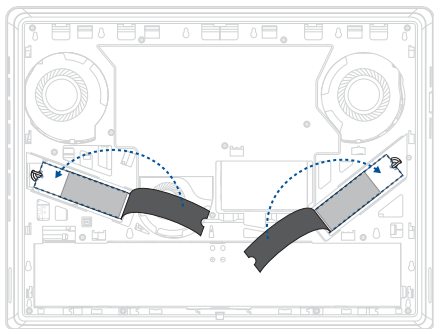

RAM module

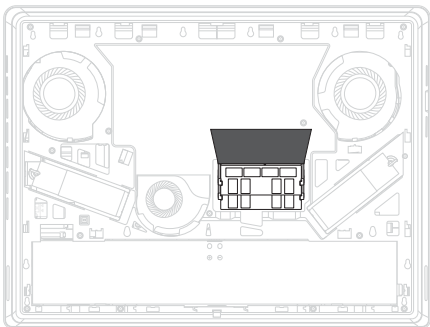

Before you begin

1. Read the **Safety Precautions** and **Pre-repair Checklist**.
2. Remove the bottom cover.

Removal

1. Lift the absorber sheet.

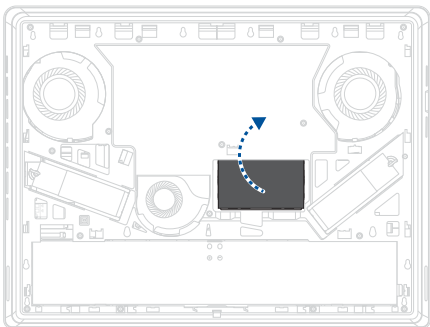

2. Push the clips outwards to remove the RAM module(s).

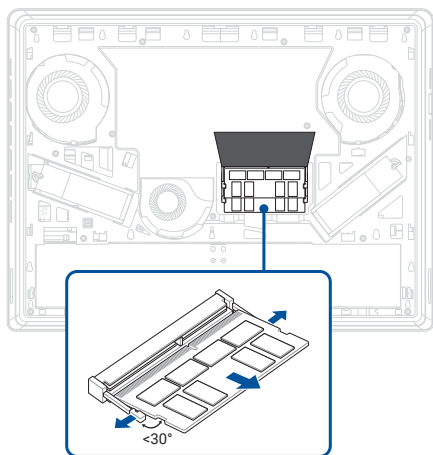

Installation

1. Align and insert the RAM module(s) into the RAM module slot(s).

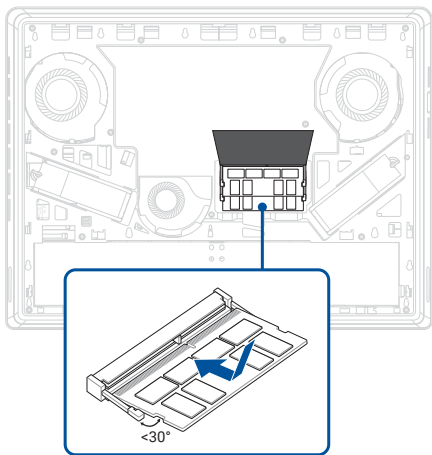

2. Put the absorber sheet back.
3. Install the components you removed in the *Before you begin* section.

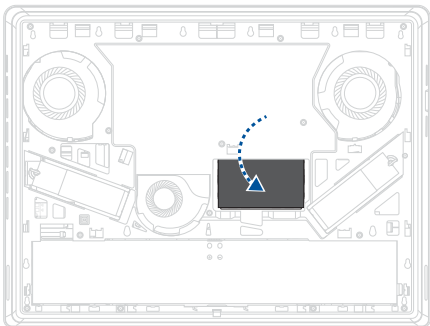

Compartment cover

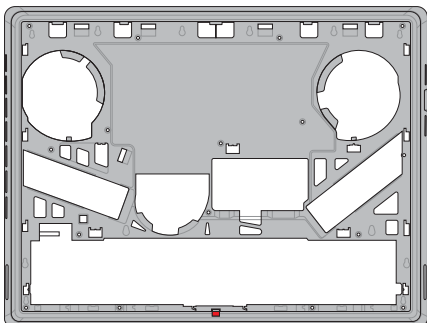

Before you begin

1. Read the **Safety Precautions** and **Pre-repair Checklist**.
2. Remove the bottom cover.

Screw list

- ⊕ M2.0 X 10.0L (14pcs)
- ⊕ M2.0 X 5.5L (2pcs)

Removal

1. Disconnect the cable from the motherboard.

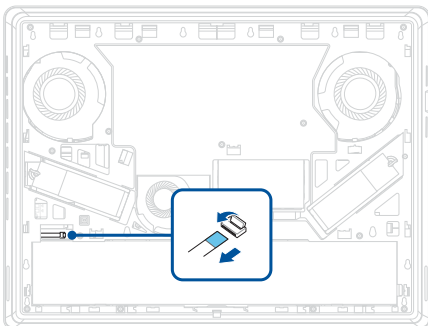

2. Remove the screw(s) from the compartment cover.
3. Use the plastic blade to pry open the indicated area of the bottom cover as shown in the illustration below.
4. Remove the bottom cover.

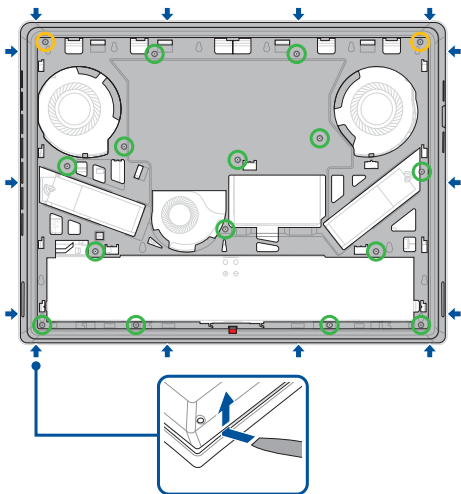

5. Turn the compartment cover over, then disconnect and remove the cable from the back of the compartment cover.

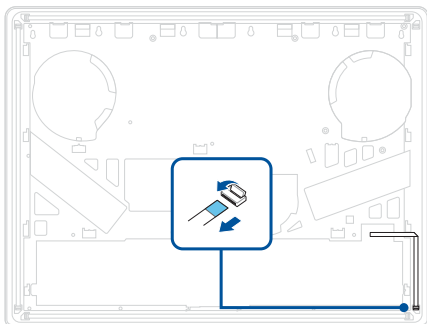

Installation

1. Reconnect the cable to the back of the compartment cover.

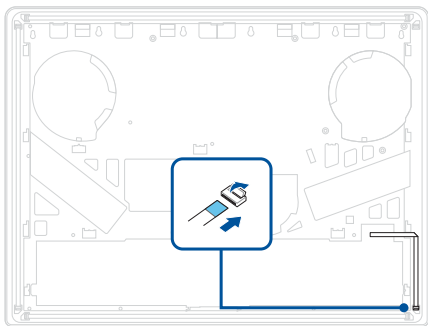

2. Turn the compartment cover over, then install the compartment cover.
3. Gently press down on the compartment cover until it clicks into place.
4. Secure the compartment cover using the screw(s) you removed earlier.

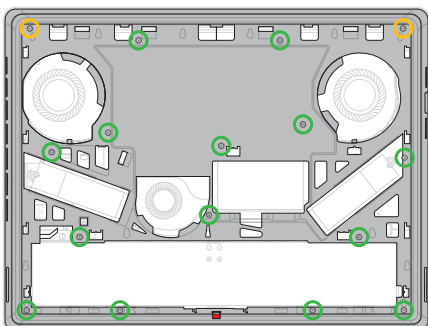

5. Reconnect the cable to the motherboard.
6. Install the components you removed in the *Before you begin* section.

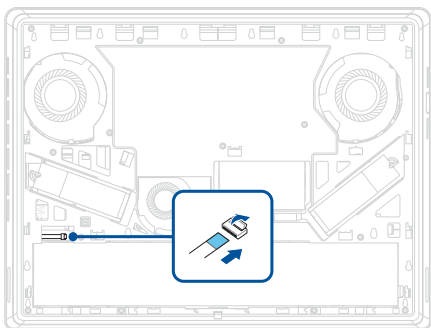

WLAN module

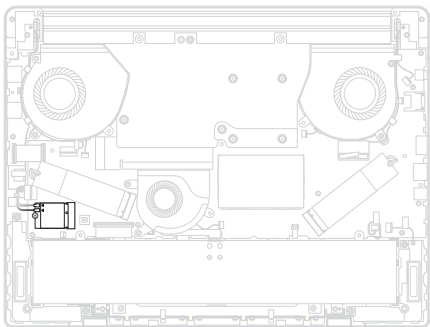

Before you begin

1. Read the **Safety Precautions** and **Pre-repair Checklist**.
2. Remove the bottom cover.
3. Remove the following components:
 - Compartment cover

Screw list

- ⊕ M2.0 X 2.5L (1pc)

Removal

1. Remove the polyester film.
2. Disconnect the antenna cable(s), then remove the screw and remove the WLAN module.

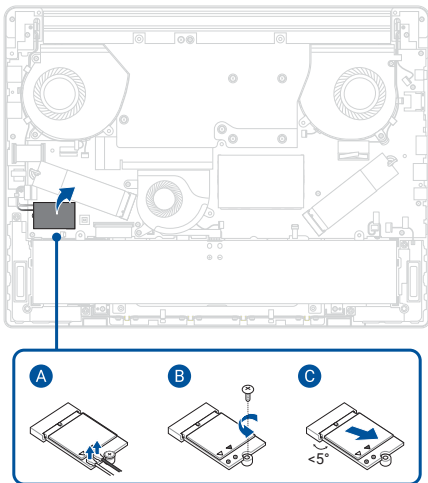

Installation

1. Install the WLAN module, then secure the WLAN module using the screw you removed earlier and reconnect the antenna cable(s).
2. Install the components you removed in the *Before you begin* section.

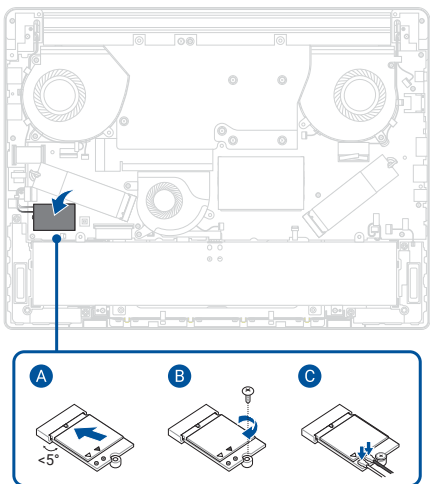

Woofer speakers

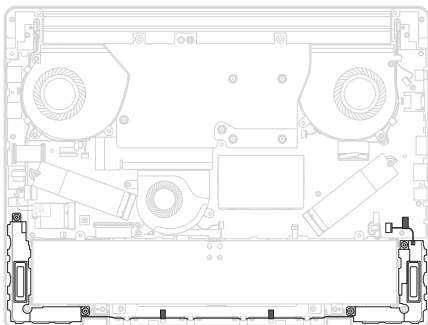

Before you begin

1. Read the **Safety Precautions** and **Pre-repair Checklist**.
2. Remove the bottom cover.
3. Remove the following components:
 - Compartment cover

Removal

1. Disconnect the cable.
2. Remove the tape, then remove the woofer speaker cable from the cable guide(s).
3. Remove the woofer speakers.

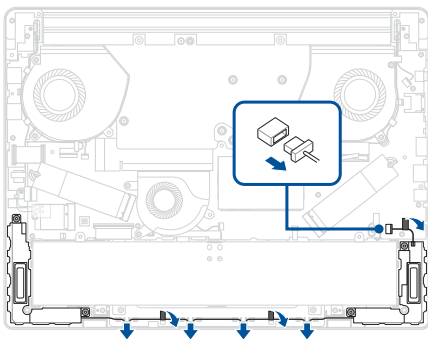

Installation

1. Install the woofer speakers.
2. Route the speaker cable through the cable guide(s).

IMPORTANT! Damage may occur if cables are not properly routed through the cable guides. Confirm that all cables are routed through each of the indicated cable guides before proceeding.

3. Reattach the tape.
4. Install the components you removed in the *Before you begin* section.

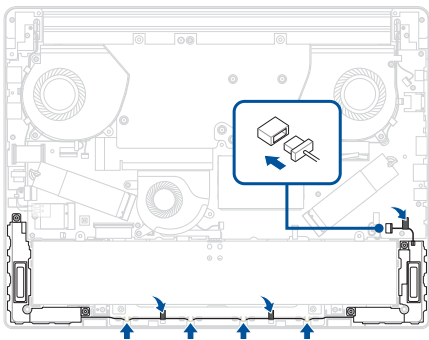

I/O board

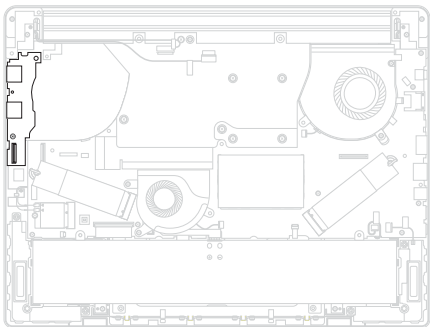

Before you begin

1. Read the **Safety Precautions** and **Pre-repair Checklist**.
2. Remove the bottom cover.
3. Remove the following components:
 - Compartment cover

Screw list

- ⊕ M2.0 X 5.5L (2pcs)
- ⊕ M2.0 X 2.5L (1pc)

Removal

1. Remove the tape.
2. Disconnect the I/O board cable from the motherboard and the I/O board, then remove the cable.

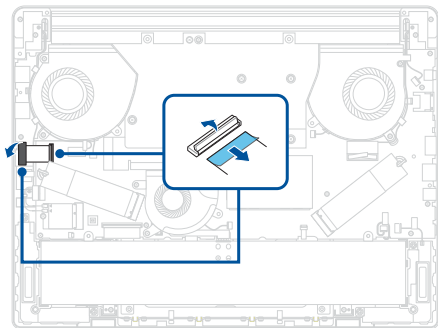

3. Disconnect the cable, then remove the cable from the cable guide(s).

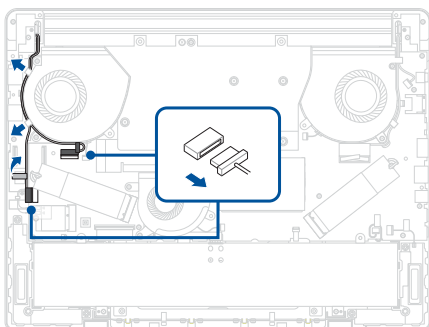

4. Disconnect the cable.
5. Remove the screw(s), then remove the fan.

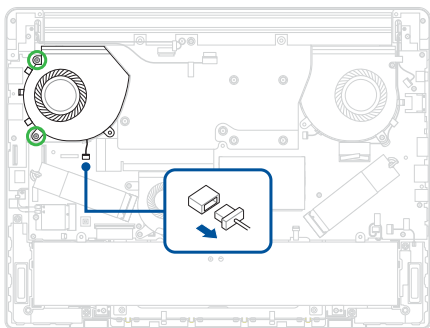

6. Remove the screw, then remove the I/O board.

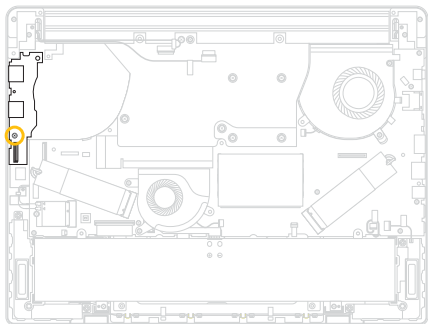

Installation

1. Install the I/O board, then secure the I/O board using the screw you removed earlier.

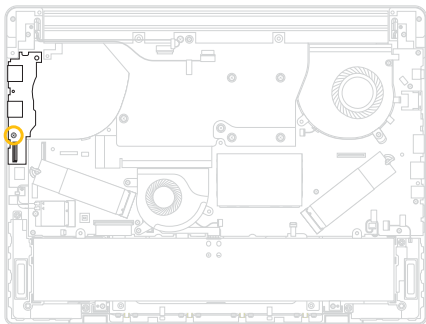

2. Install the fan, then secure the fan using the screw(s) you removed earlier.
3. Reconnect the cable.

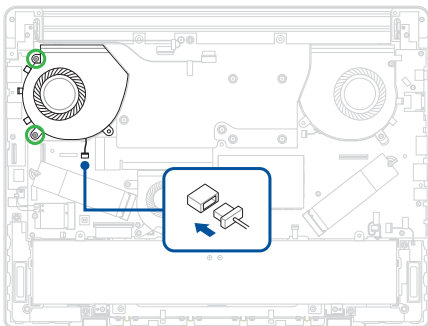

4. Route the cable through the cable guide(s).

IMPORTANT! Damage may occur if cables are not properly routed through the cable guides. Confirm that all cables are routed through each of the indicated cable guides before proceeding.

5. Reconnect the cable.

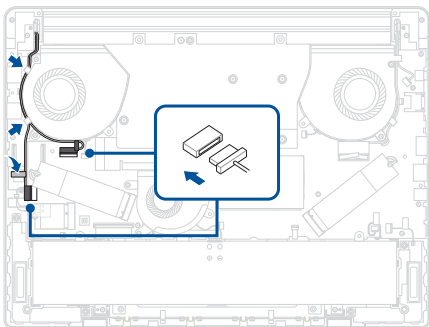

6. Reconnect the I/O board cable to the motherboard and the I/O board.
7. Reattach the tape.
8. Install the components you removed in the *Before you begin* section.

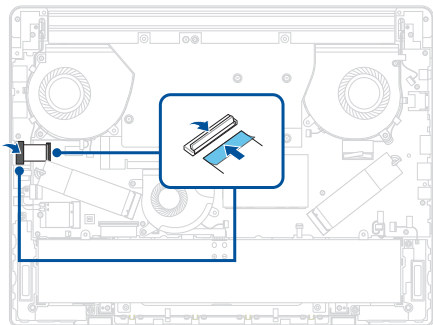

Fan module

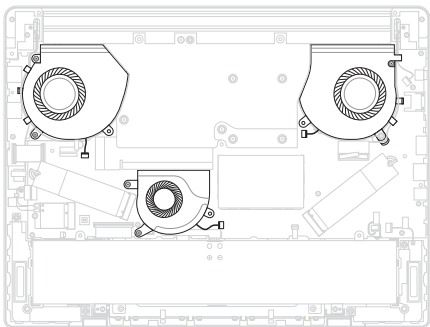

Before you begin

1. Read the **Safety Precautions** and **Pre-repair Checklist**.
2. Remove the bottom cover.
3. Remove the following components:
 - Compartment cover

Screw list

- ⊕ M2.0 X 5.5L (6pcs)

Removal

1. Remove the tape.
2. Disconnect the I/O board cable from the motherboard and the I/O board, then remove the cable.

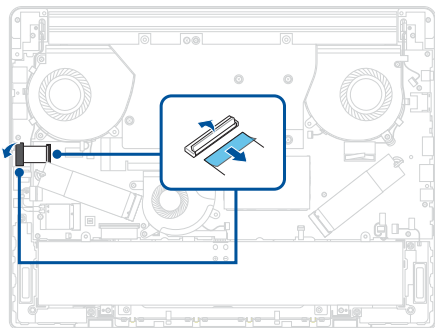

3. Remove the screw.
4. Disconnect the cable, then remove the cable from the cable guide(s).

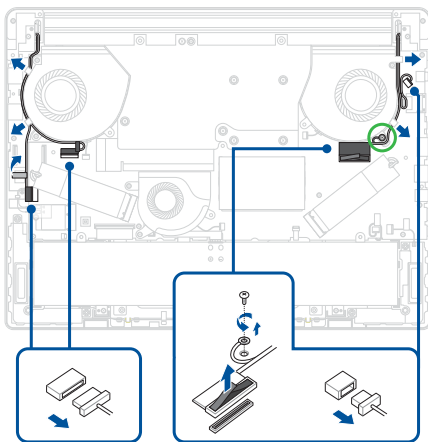

5. Remove the rest of the screw(s) from the fan module(s), then remove the fan module(s).

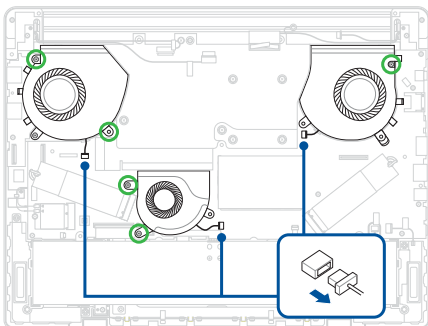

Installation

1. Align and install the fan module(s).
2. Secure the fan module(s) using the screw(s) you removed earlier, then reconnect the fan cable(s).

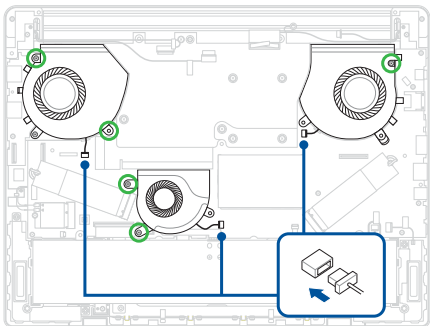

3. Route the cable(s) through the cable guide(s).

IMPORTANT! Damage may occur if cables are not properly routed through the cable guides. Confirm that all cables are routed through each of the indicated cable guides before proceeding.

4. Secure the cable using the screw you removed earlier.
5. Reconnect the cable(s).

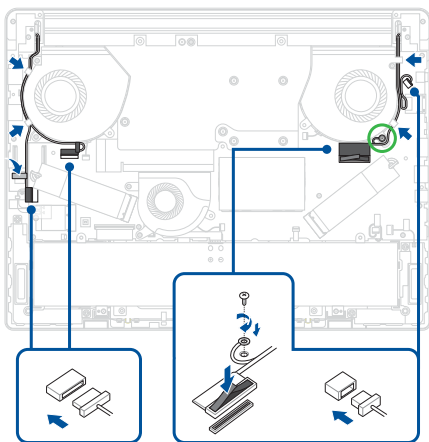

6. Reconnect the I/O board cable to the motherboard and the I/O board.
7. Reattach the tape.
8. Install the components you removed in the *Before you begin* section.

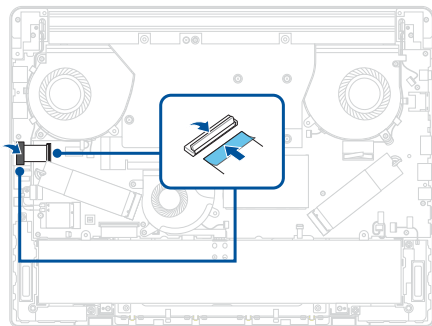

Battery

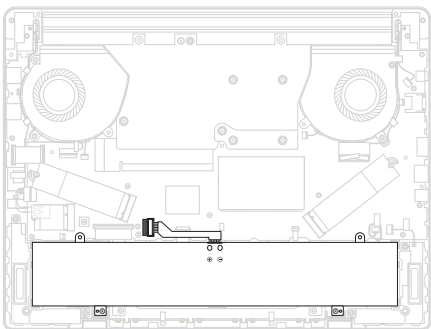

Before you begin

1. Read the **Safety Precautions** and **Pre-repair Checklist**.
2. Remove the bottom cover.
3. Remove the following components:
 - Compartment cover

Screw list

- ⊕ M2.0 X 5.5L (2pcs)
- ⊕ M2.0 X 4.0L (2pcs)

Removal

1. Remove the screw(s) from the fan module, then remove the fan module.

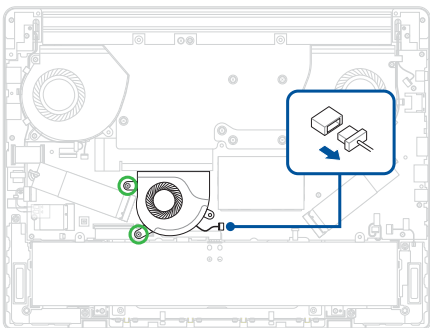

2. Disconnect the battery power cable.

IMPORTANT!

- Disconnect the battery power cable by lifting the side with the red wires first.
 - Serious risk of fire or explosion may occur if the battery is punctured. If you are uncertain about proceeding, stop and contact an authorized service center for assistance.
-

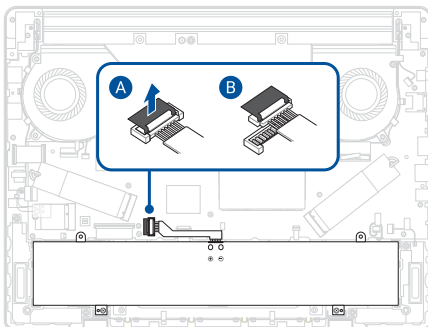

3. Remove the screw(s) from the battery.
4. Remove the battery.

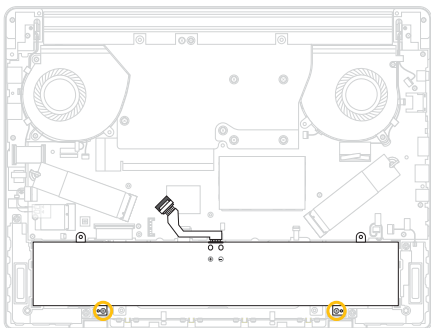

5. Remove the battery power cable from the battery.

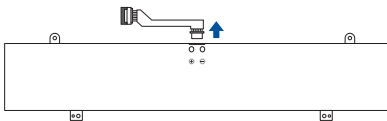

Installation

1. Connect the battery power cable to the battery.

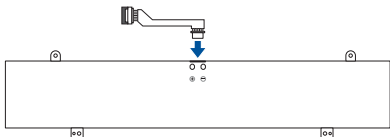

2. Install the battery.
3. Secure the battery using the screw(s) you removed earlier.

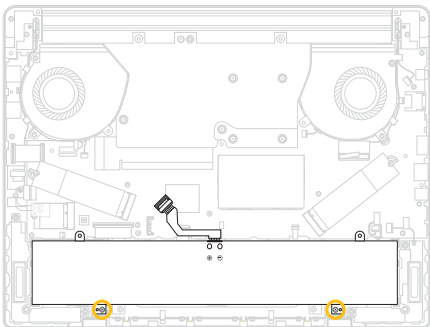

4. Reconnect the battery power cable.

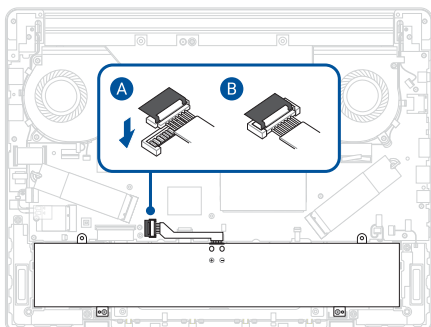

5. Install the fan module.
6. Secure the fan module using the screw(s) you removed earlier, then reconnect the fan cable.
7. Install the components you removed in the *Before you begin* section.

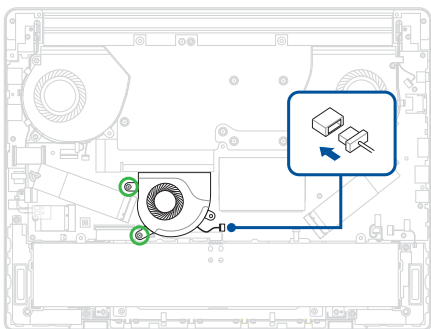

Vapor chamber heat sink and motherboard

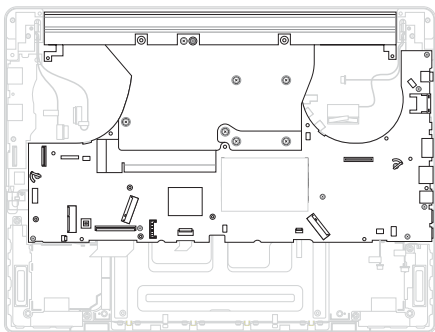

Before you begin

WARNING! The heat sink contains liquid metal and should only be removed by authorized service personnel. Significant damage may occur to motherboard components if the heat sink is improperly removed.

IMPORTANT! Thermal paste, thermal pads, liquid metal, or other thermal interface materials must be thoroughly removed and replaced if this component is removed. Ensure that replacement materials are available before proceeding, or contact an authorized service center for assistance.

1. Read the **Safety Precautions** and **Pre-repair Checklist**.
2. Remove the bottom cover.

3. Remove the following components:
- Compartment cover
 - Fan module
 - Battery

Screw list

- ⊕ M2.0 X 5.5L (1pc)
- ⊕ M2.0 X 4.0L (7pcs)

Removal

1. Disconnect the cable(s) from the motherboard as shown in the illustration below.

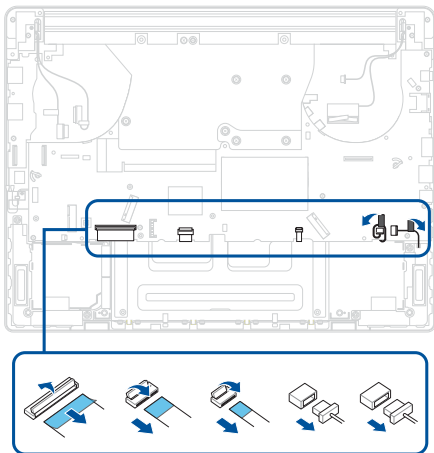

2. Remove the screw(s) from the motherboard.
3. Carefully remove the motherboard with the heat sink installed on top.

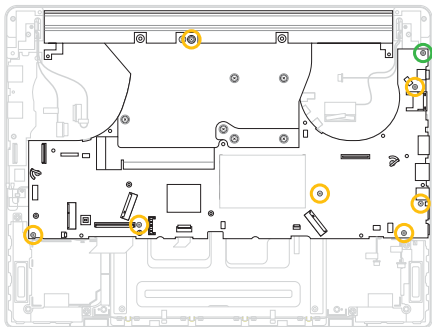

Installation

1. Align and install the motherboard with the heat sink installed on top.
2. Secure the motherboard using the screw(s) you removed earlier.

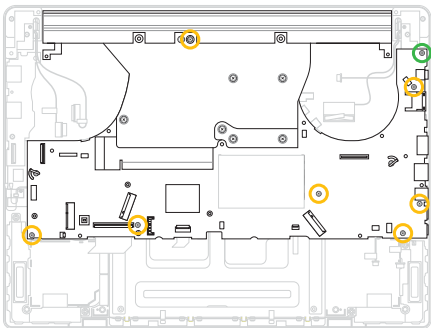

3. Reconnect the cable(s) as shown in the illustration below.
4. Install the components you removed in the *Before you begin* section.

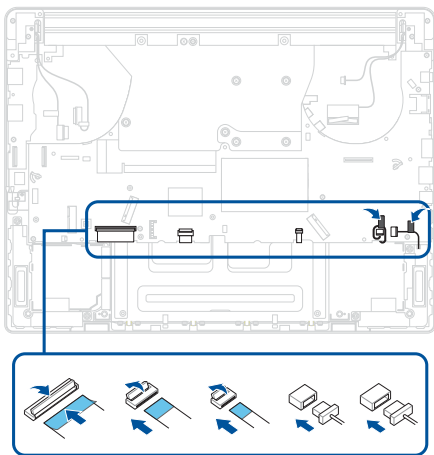

Tweeter speakers (on selected models)

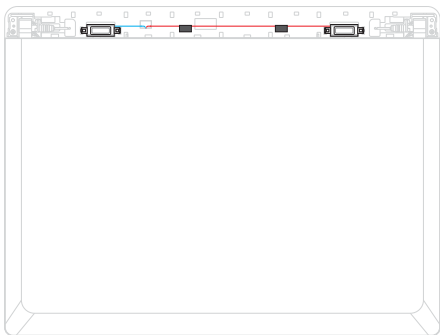

Before you begin

1. Read the **Safety Precautions** and **Pre-repair Checklist**.
2. Remove the bottom cover.
3. Remove the following components:
 - Compartment cover
 - Fan module
 - Battery
 - Vapor chamber heat sink and motherboard

Screw list

- ⊕ M2.0 X 5.5L (2pcs)

Removal

1. Remove the tape to release the cable.

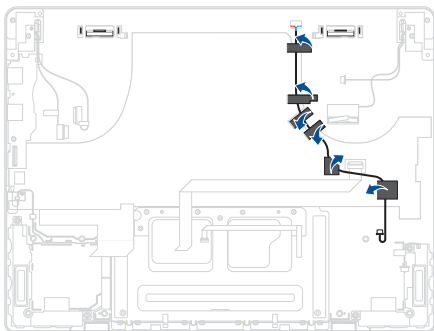

2. Remove the screw(s).

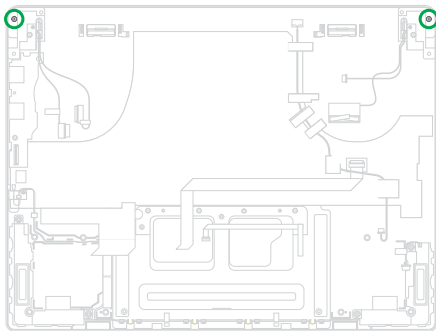

3. Turn the device over, then remove the hinge cover.



4. Remove the tape.

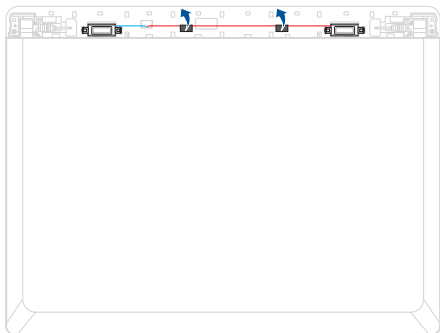

5. Carefully remove the tweeter speaker cable through the opening.

IMPORTANT! Handle the cable(s) carefully through the opening to avoid damage.

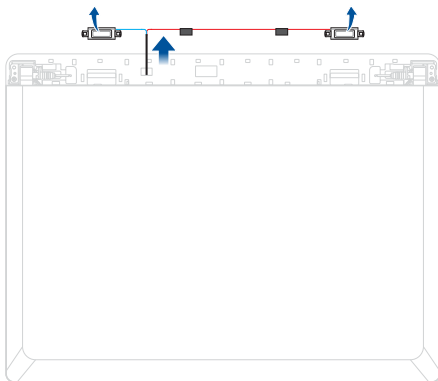

Installation

1. Carefully thread the tweeter speaker cable through the opening as shown in the illustration below.

IMPORTANT! Handle the cable(s) carefully through the opening to avoid damage.

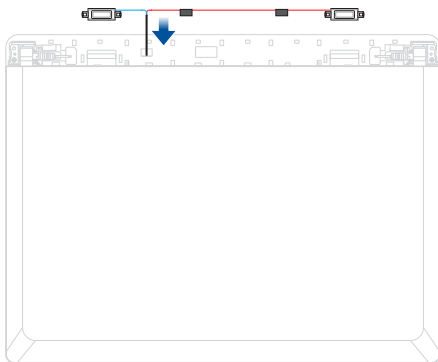

2. Align and install the tweeter speakers.

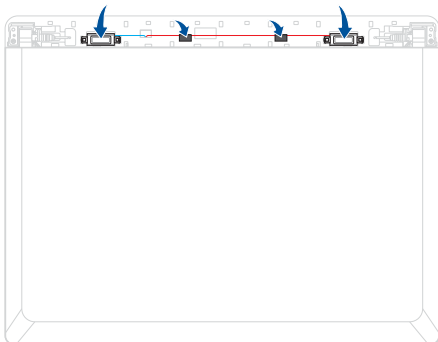

3. Turn the device over, then install the hinge cover.



4. Turn the device over again, then secure the hinge cover using the screw(s) you removed earlier.

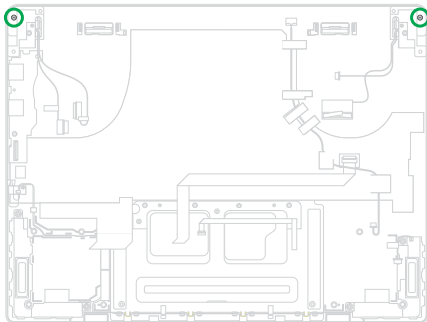

5. Reattach the tape.
6. Install the components you removed in the Before you begin section.

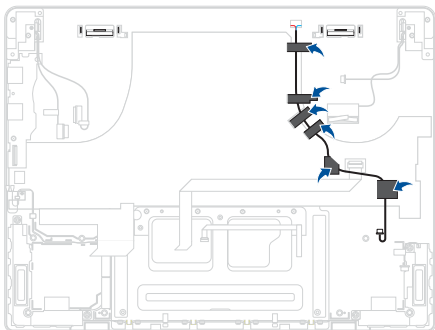

Display panel module

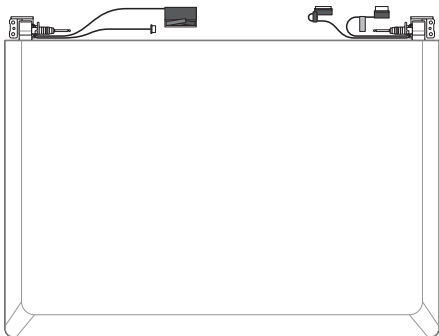

Before you begin

1. Read the **Safety Precautions** and **Pre-repair Checklist**.
2. Remove the bottom cover.
3. Remove the following components:
 - Compartment cover

Screw list

- ⊕ M2.0 X 5.5L (3pcs)
- ⊕ M2.0 X 4.0L (4pcs)

Removal

1. Remove the screw.
2. Disconnect the cable(s), then remove the cable(s) from the cable guide(s).

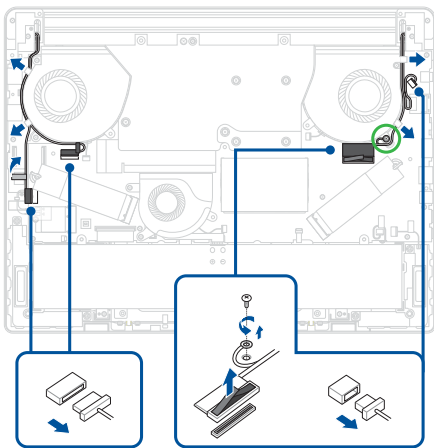

3. Remove the screw(s).

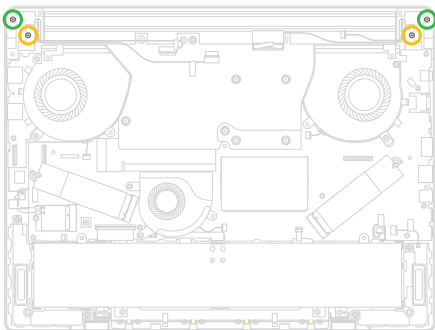

4. Turn the device over, then remove the hinge cover.



5. Remove the screw(s).
6. Grasp the left side and the right side of the display panel module with both hands near the hinges, then lift to remove the display panel module.

IMPORTANT! Handle the cable(s) carefully through the opening to avoid damage.

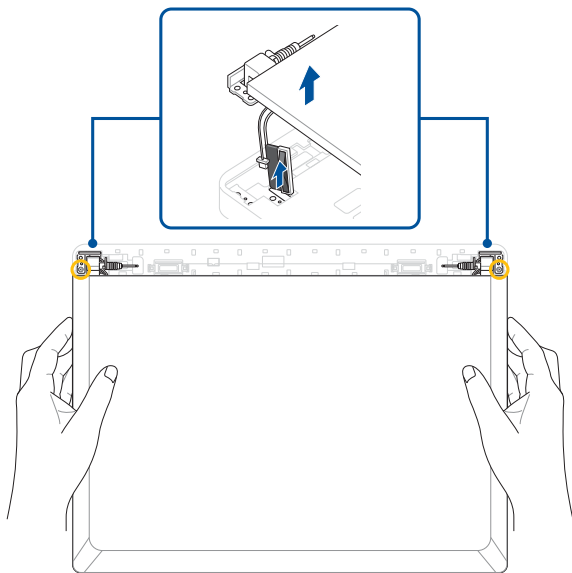

Installation

1. Align and install the display panel module.

IMPORTANT! Handle the cable(s) carefully through the opening to avoid damage.

2. Secure the display panel module using the screw(s) you removed earlier.

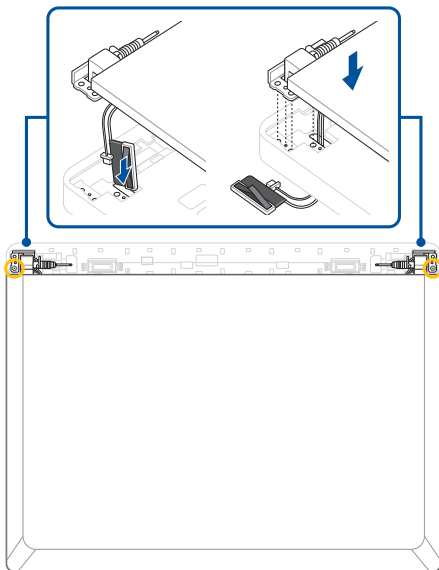

3. Install the hinge cover.



4. Turn the device over, then secure the hinge cover using the screw(s) you removed earlier.

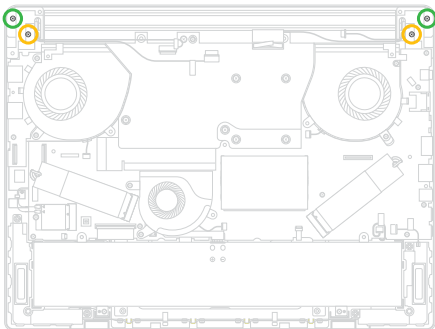

5. Route the cable(s) through the cable guide(s).

IMPORTANT! Damage may occur if cables are not properly routed through the cable guides. Confirm that all cables are routed through each of the indicated cable guides before proceeding.

6. Secure the cable using the screw you removed earlier, then reconnect the rest of the cable(s).
7. Install the components you removed in the Before you begin section.

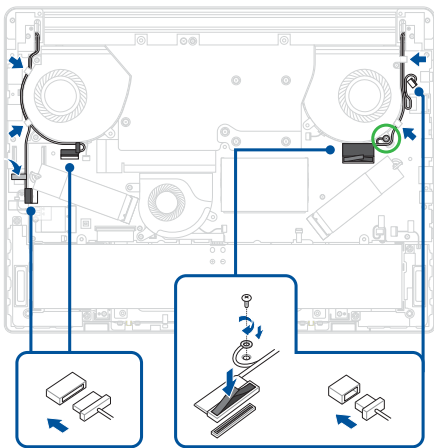

Touchpad

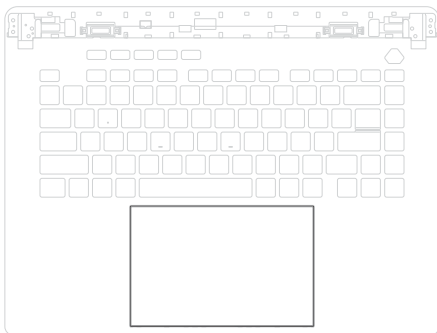

Before you begin

1. Read the **Safety Precautions** and **Pre-repair Checklist**.
2. Remove the bottom cover.
3. Remove the following components:
 - Compartment cover
 - Fan module
 - Battery
 - Vapor chamber heat sink and motherboard
 - Display panel module

Screw list

- ⊕ M2.0 X 2.5L (4pcs)

Removal

1. Disconnect and remove the touchpad FFC cable from the touchpad.
2. Remove the screw(s).

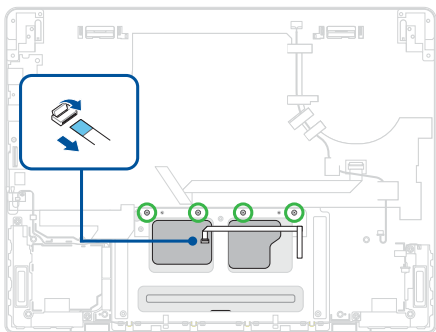

3. Turn over the keyboard module, then remove the touchpad module at the angle as shown in the illustration below.

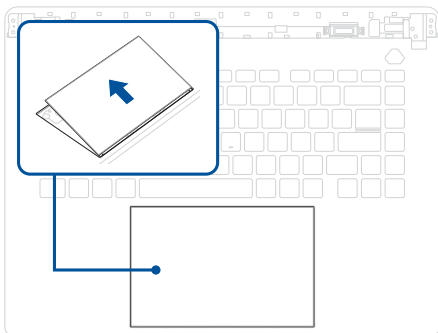

4. Remove the tape.

Standard touchpad models

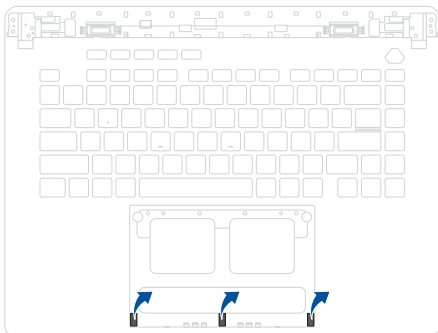

Touchpad with NumberPad models

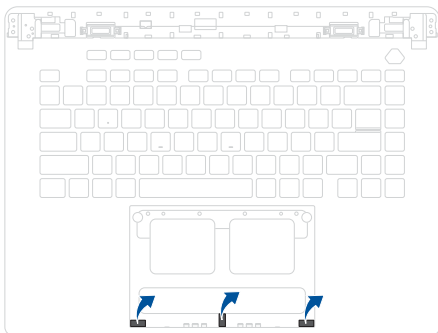

Installation

1. Align and reattach the tape.

Standard touchpad models

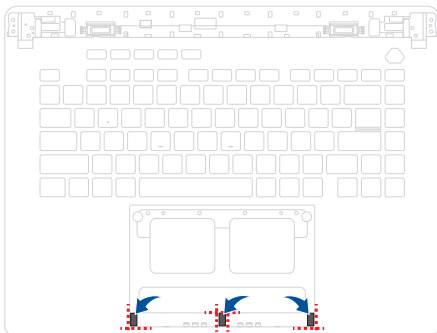

Touchpad with NumberPad models

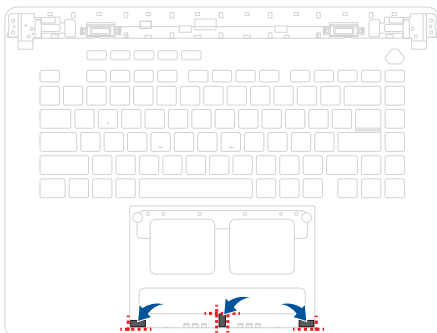

2. Align and install the touchpad at the angle as shown in the illustration below.

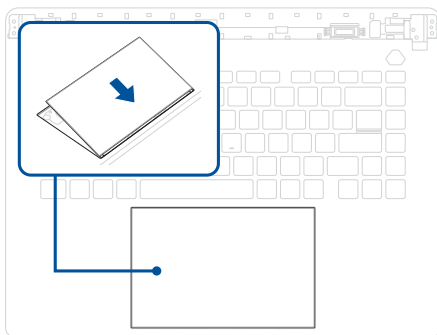

3. Turn over the keyboard module, then secure the touchpad using the screw(s) you removed earlier.
4. Reconnect the cable.
5. Install the components you removed in the *Before you begin* section.

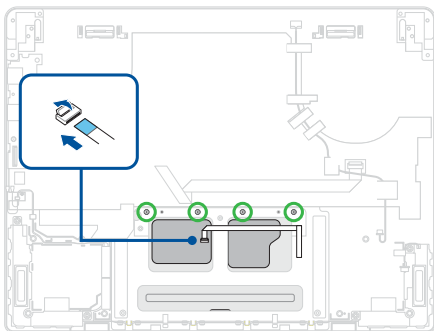

Antenna cable

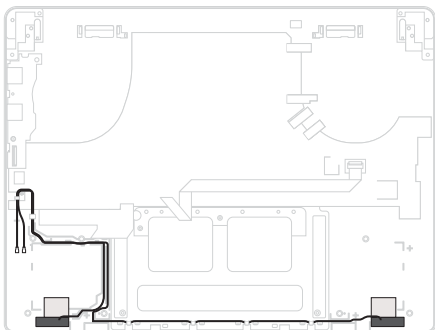

Before you begin

1. Read the **Safety Precautions** and **Pre-repair Checklist**.
2. Remove the bottom cover.
3. Remove the following components:
 - M.2 SSD module
 - RAM module
 - Compartment cover
 - WLAN module
 - Woofer speakers
 - I/O board

- Fan module
- Battery
- Vapor chamber heat sink and motherboard
- Tweeter speakers (on selected models)
- Display panel module
- Touchpad

Removal

1. Remove the antenna cable(s) from the cable guide(s) as shown in the illustration below.

IMPORTANT! The antenna cable(s) cannot be reused once removed.

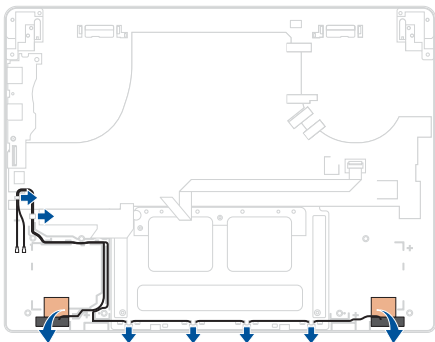

Installation

1. Align and install the antenna cable(s).
2. Route the cable(s) through the cable guide(s).

IMPORTANT! Damage may occur if cables are not properly routed through the cable guides. Confirm that all cables are routed through each of the indicated cable guides before proceeding.

3. Install the components you removed in the *Before you begin* section.

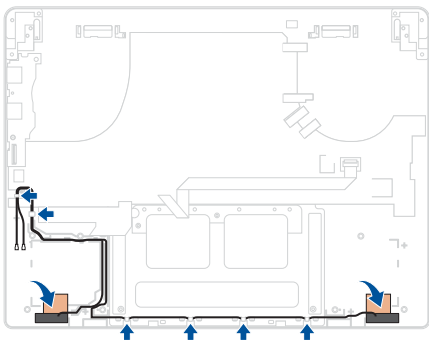

Keyboard module

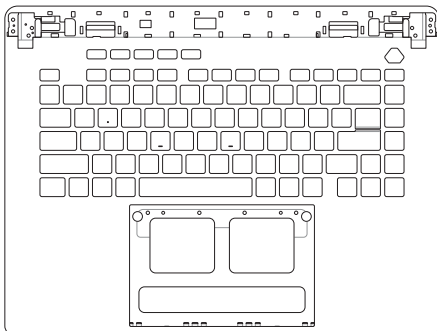

Before you begin

1. Read the **Safety Precautions** and **Pre-repair Checklist**.
2. Remove the bottom cover.
3. Remove the following components:
 - M.2 SSD module
 - RAM module
 - Compartment cover
 - WLAN module
 - Woofer speakers
 - I/O board

- Fan module
- Battery
- Vapor chamber heat sink and motherboard
- Tweeter speakers (on selected models)
- Display panel module
- Touchpad
- Antenna cable

Removal

Disconnect and remove the cable.

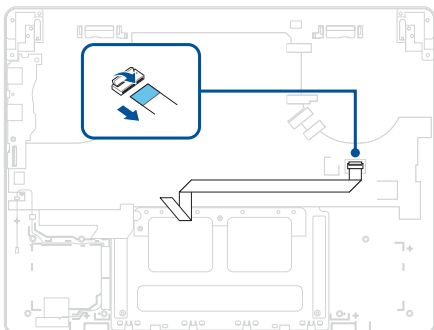

Installation

1. Reconnect the FFC cable.
2. Install the components you removed in the *Before you begin* section.

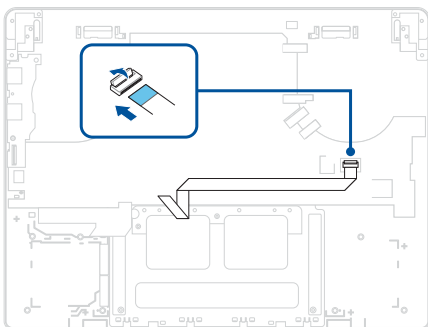

Display bezel

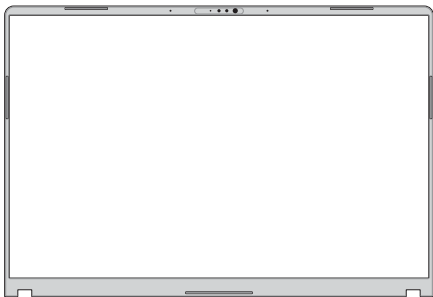

Before you begin

IMPORTANT! This component is fragile. Damage may occur if the service procedure is performed incorrectly. If you are uncertain about proceeding, stop and contact an authorized service center for assistance.

1. Read the **Safety Precautions** and **Pre-repair Checklist**.
2. Remove the bottom cover.
3. Remove the following components:
 - Compartment cover
 - Display panel module

Removal

1. From the inside of the top-left or top-right corner of the display bezel, use a plastic blade to carefully pry the bezel loose and create a gap between the display bezel and the top cover.

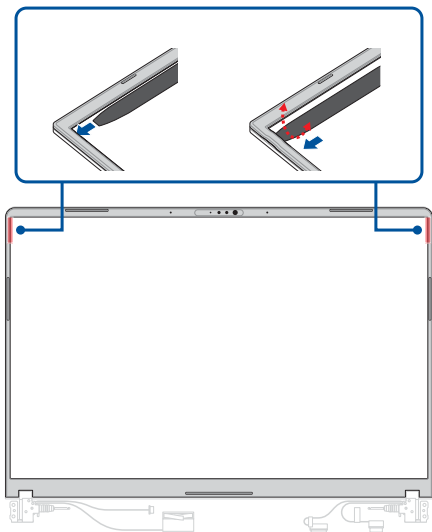

2. Ensure the gap is sufficient for your fingers to grip, then begin to gently separate the display bezel from the top cover following the direction indicated by the dotted arrows.

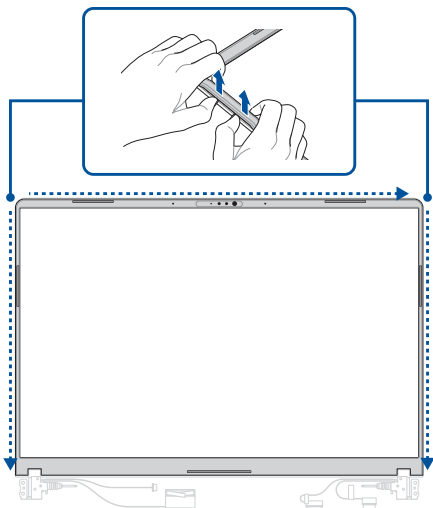

3. Carefully pry the bottom side of the bezel loose without removing the display bezel.

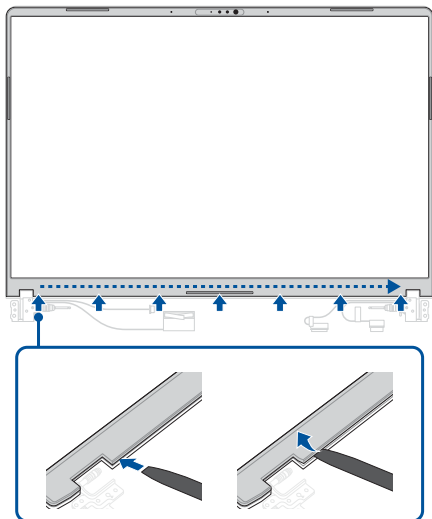

4. Gently slide a plastic opening card under the bottom edge of the display bezel to separate the adhered part, then carefully remove the bezel.

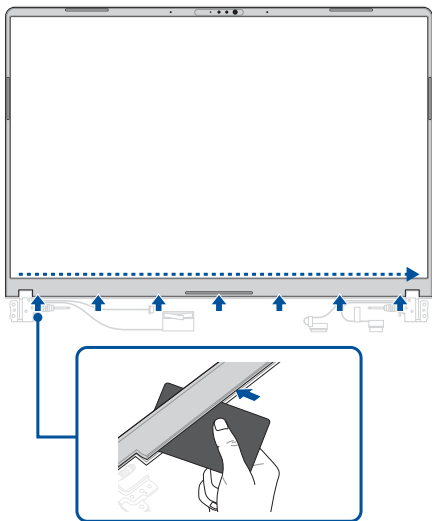

Installation

1. Remove the release liner(s) from the tape on the bezel.

NOTE: The tape cannot be reused. Remove any adhesive residue and use new tape when reinstalling components.

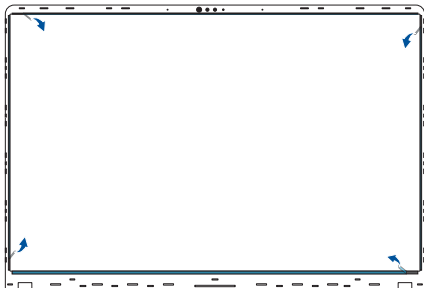

2. Align and install the bezel.
3. Install the components you removed in the *Before you begin* section.

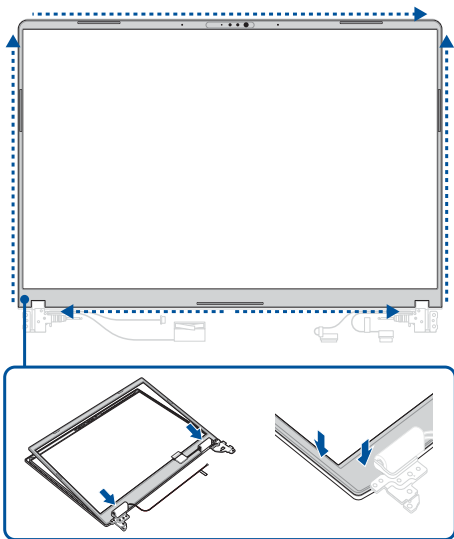

Display panel

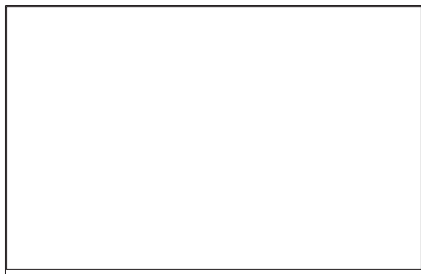

Before you begin

IMPORTANT!

- This component is fragile. Damage may occur if the service procedure is performed incorrectly. If you are uncertain about proceeding, stop and contact an authorized service center for assistance.
 - Do not bend the display panel in any way to avoid risk of display panel leakage.
-

1. Read the **Safety Precautions** and **Pre-repair Checklist**.
2. Remove the bottom cover.
3. Remove the following components:
 - Compartment cover
 - Display panel module
 - Display panel bezel

Removal

1. Locate the tip of the stretch release tape, then carefully pull out the stretch release tape as shown in the illustration below.

IMPORTANT! Maintain a flat angle and constant speed when pulling the stretch release tape. Excessive force may damage the stretch release tape and prevent removal of the display panel.

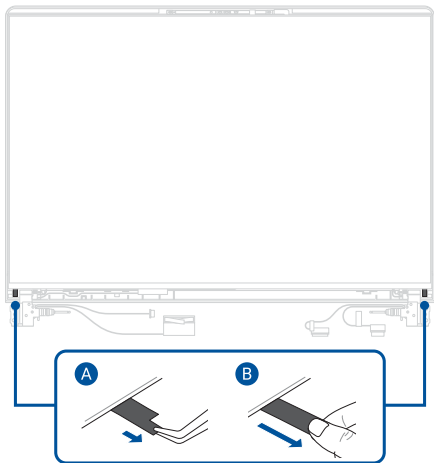

2. Lift the display panel as shown in the illustration below.
3. Release the cable from the cable guide.

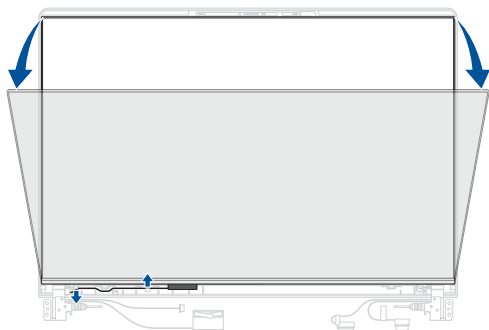

4. Disconnect the cable from the rear side of the display panel.

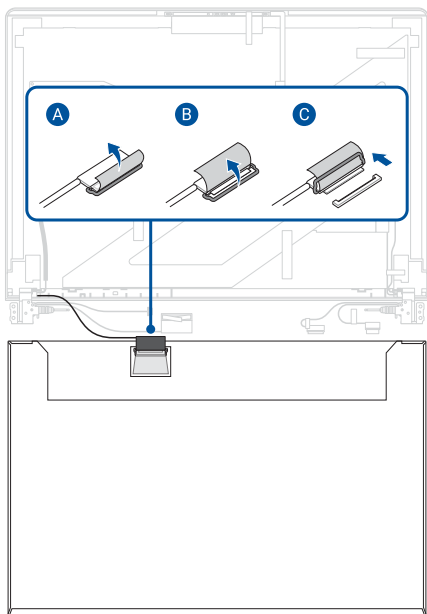

Installation

1. Reconnect the cable to the rear side of the display panel.

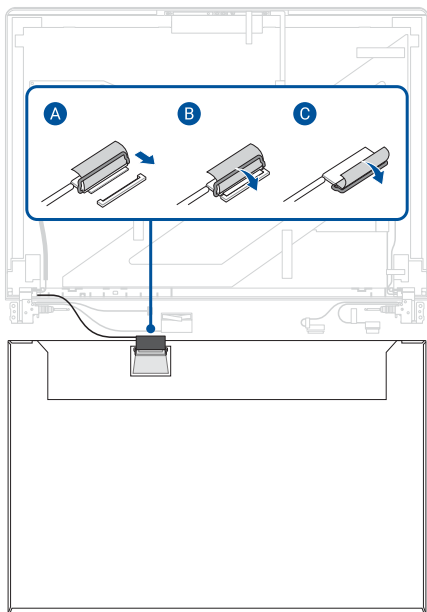

2. Remove the release liner(s) from the bottom side of the stretch release tape.
3. Align and attach the stretch release tape to the top cover.
4. Remove the release liner(s) from the top side of the stretch release tape.

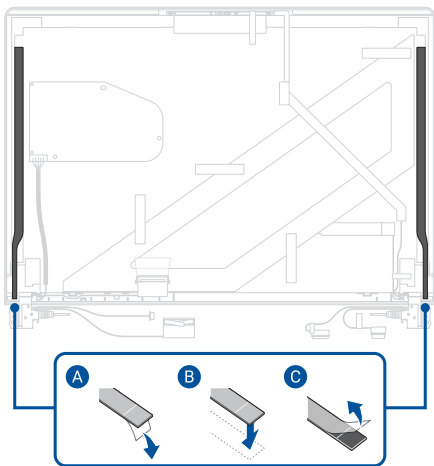

5. Align and install the display panel.
6. Route the cable through the cable guide.

IMPORTANT! Damage may occur if cables are not properly routed through the cable guides. Confirm that all cables are routed through each of the indicated cable guides before proceeding.

7. Install the components you removed in the *Before you begin* section.

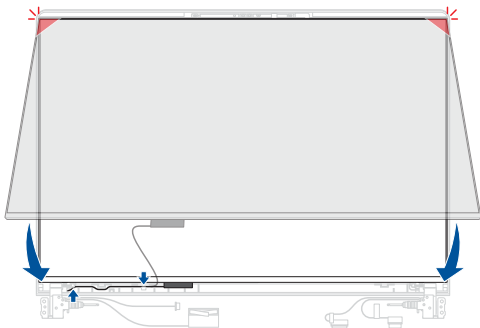

eDP cable

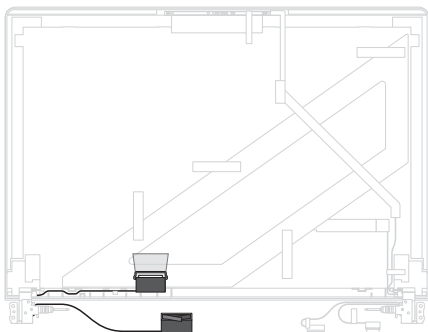

Before you begin

1. Read the **Safety Precautions** and **Pre-repair Checklist**.
2. Remove the bottom cover.
3. Remove the following components:
 - Compartment cover
 - Display panel module
 - Display bezel
 - Display panel

Removal

1. Turn the hinge on the left to the angle as shown in the illustration below.
2. Remove the hinge cap.
3. Carefully remove the eDP cable.

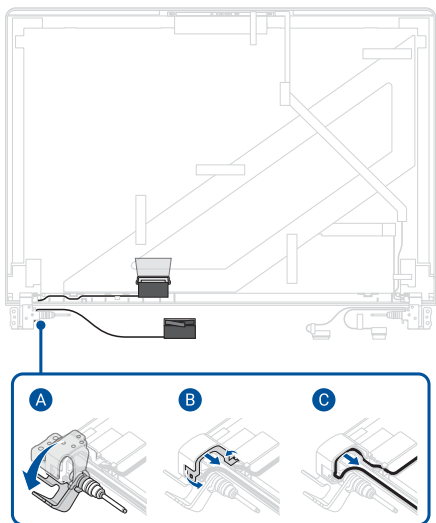

Installation

1. Position and press a part of the eDP cable within the left hinge cap as shown in the illustration below.
2. Install the left hinge cap.
3. Turn the hinge to the angle as shown in the illustration below.
4. Install the components you removed in the *Before you begin* section.

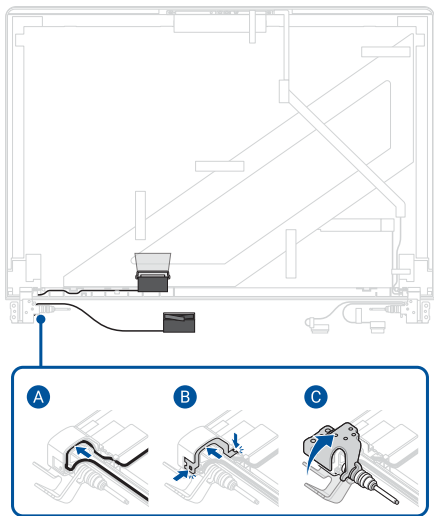

Camera module

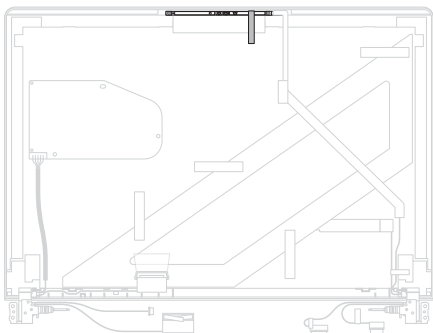

Before you begin

IMPORTANT! This component is fragile. Damage may occur if the service procedure is performed incorrectly. If you are uncertain about proceeding, stop and contact an authorized service center for assistance.

1. Read the **Safety Precautions** and **Pre-repair Checklist**.
2. Remove the bottom cover.
3. Remove the following components:
 - Compartment cover
 - Display panel module
 - Display panel

Removal

1. Disconnect the cable from the camera module.
2. Carefully remove the camera module, then remove the rubber caps from the camera module.

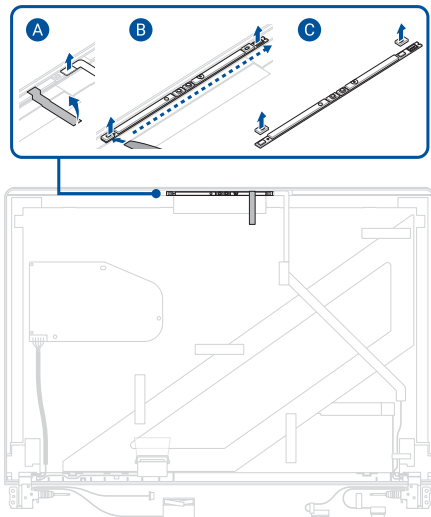

Installation

1. Attach the rubber caps to the camera module, then install the camera module.
2. Reconnect the cable to the camera module.
3. Install the components you removed in the *Before you begin* section.

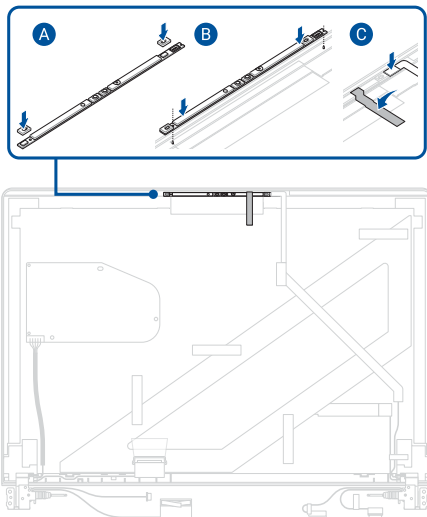

Logo backlight module (on selected models)

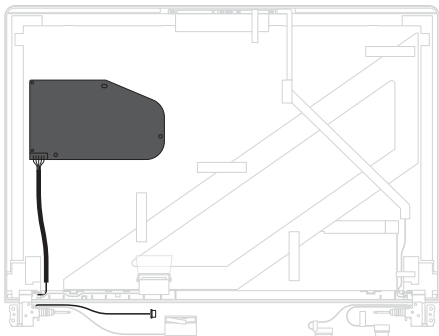

1. Read the **Safety Precautions** and **Pre-repair Checklist**.
2. Remove the bottom cover.
3. Remove the following components:
 - Compartment cover
 - Display panel module
 - Display panel

Removal

1. Turn the hinge on the left to the angle as shown in the illustration below.
2. Remove the hinge cap.
3. Carefully pull out the cable.

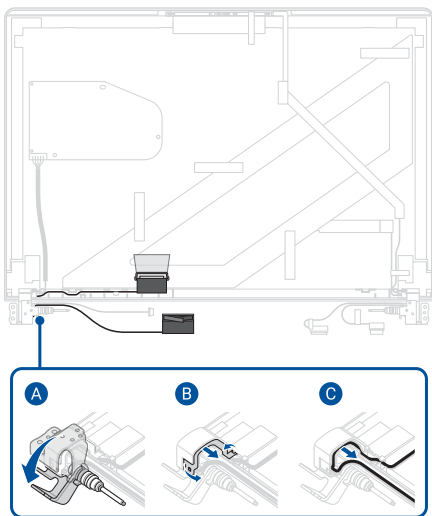

4. Remove the cable from the inside.
5. Remove the logo backlight module.

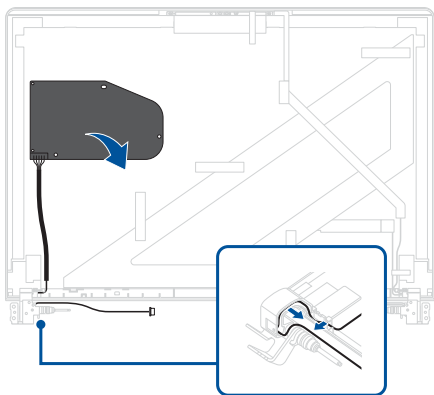

Installation

1. Align and attach the logo backlight module.
2. Route the cable and position a part of the cable within the left hinge cap as shown in the illustration below.

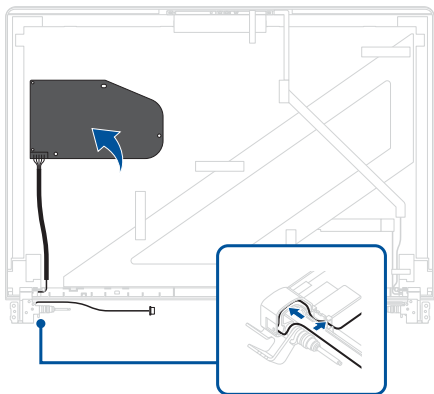

3. Position and press a part of the cable within the hinge cap as shown in the illustration below.
4. Install the left hinge cap.
5. Turn the hinge to the angle as shown in the illustration below.
6. Install the components you removed in the *Before you begin* section.

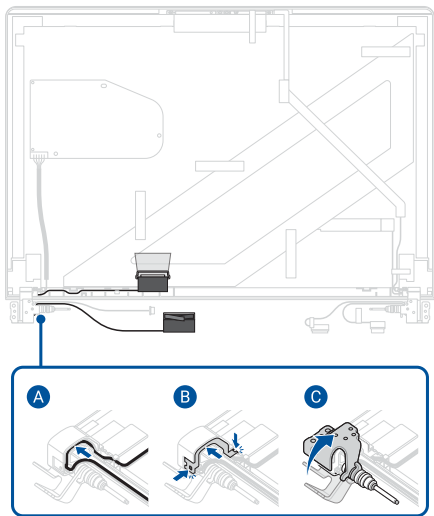

Camera cable

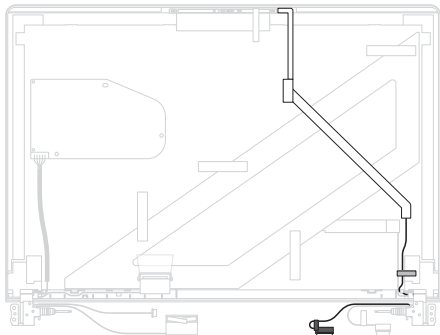

1. Read the **Safety Precautions** and **Pre-repair Checklist**.
2. Remove the bottom cover.
3. Remove the following components:
 - Compartment cover
 - Display panel module
 - Display panel

Removal

1. Remove the tape and disconnect the cable.
2. Turn the hinge on the right to the angle as shown in the illustration below.
3. Remove the hinge cap.
4. Carefully pull out the cable.

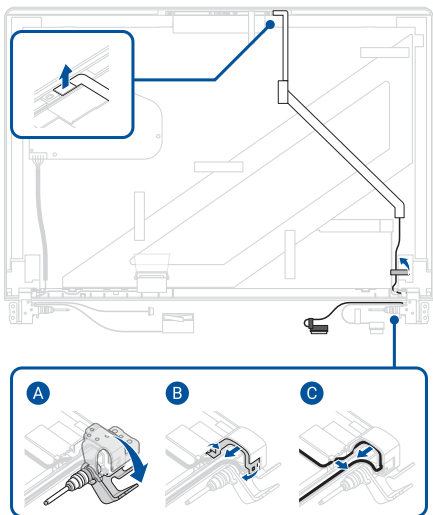

Installation

1. Reconnect the cable.
2. Position and press a part of the cable within the hinge cap as shown in the illustration below, then reattach the tape.
3. Install the hinge cap.
4. Turn the hinge to the angle as shown in the illustration below.
5. Install the components you removed in the *Before you begin* section.

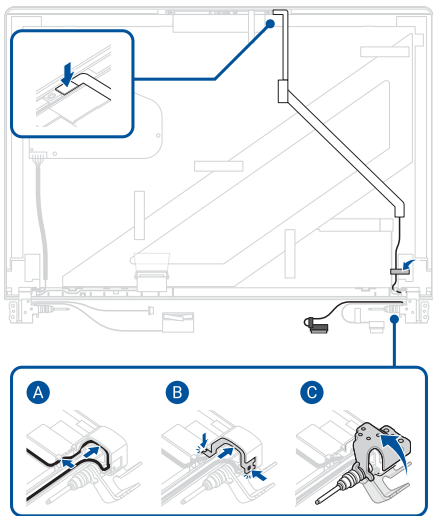

Appendices

Wiring and connection diagrams

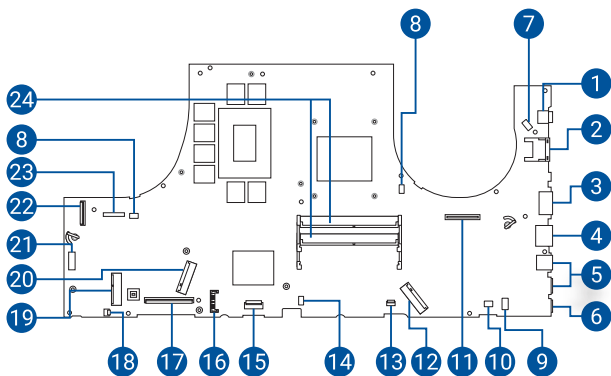

1. Power supply connector
2. LAN connector
3. HDMI connector
4. USB Type-A connector
5. USB Type-C® connector
6. Audio connector
7. Logo backlight connector*
8. Fan connector
9. Woofer speaker connector
10. Tweeter speaker connector*
11. LVDS connector
12. Main SSD connector
13. Touchpad connector
14. VRAM fan connector
15. Keyboard backlight connector
16. Battery connector
17. Keyboard membrane connector
18. O-Lens connector
19. WLAN module connector
20. Second SSD connector
21. Matrix connector*
22. I/O board connector
23. Camera connector
24. RAM module slot

* On selected models

