

QSFP112-400GB-DR4-AO

MSA and TAA 400GBase-DR4 QSFP112 Transceiver (SMF, 1310nm, 500m, MPO, DOM) CMIS 5.0

Features

- Compliant with IEEE Std 802.3bs and 802.3ck on 400Gbps Optical and Electrical Interfaces
- 4x53.125GBd PAM4 Electrical Interface
- Compliant with 400G-DR4 Optical Specifications
- CMIS 5.0 Interface
- Transmission Distance: Up to 500m SMF
- MPO-12 Receptacles
- Single 3.3V Power Supply
- Compliant with QSFP112 MSA
- RoHS Compliant and Lead-Free
- Operating Temperature: 0 to 70 Celsius

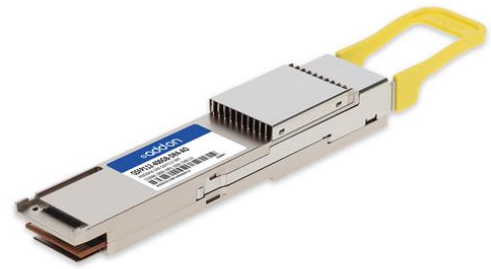

Applications

- 400GBase Ethernet
- Access and Enterprise

Product Description

This MSA Compliant QSFP112 transceiver provides 400GBase-DR4 throughput up to 500m over single-mode fiber (SMF) using a wavelength of 1310nm via an MPO connector. It is built to MSA standards and is uniquely serialized and data-traffic and application tested to ensure that they will integrate into your network seamlessly. Digital optical monitoring (DOM) support is also present to allow access to real-time operating parameters. This transceiver is Trade Agreements Act (TAA) compliant. We stand behind the quality of our products and proudly offer a limited lifetime warranty.

AddOn's transceivers are RoHS compliant and lead-free.

TAA refers to the Trade Agreements Act (19 U.S.C. & 2501-2581), which is intended to foster fair and open international trade. TAA requires that the U.S. Government may acquire only "U.S. – made or designated country end products."



Absolute Maximum Ratings

Parameter	Symbol	Min.	Typ.	Max.	Unit	Notes
Storage Temperature	Tstg	-40		85	°C	
Operating Case Temperature	Tc	0	25	70	°C	
Relative Humidity	RH	15		85	%	
Supply Voltage	Vcc	-0.5		3.6	V	
Data Rate	DR		53.125			
Modulation Format			PAM4			

Electrical Characteristics

Parameter	Symbol	Min.	Typ.	Max.	Unit	Notes
Power Supply Voltage	Vcc	3.135	3.3	3.465	V	
Power Supply Current	Icc			2.55	A	
Power Dissipation	P _{DISS}			8	W	
Transmitter						
Input Differential Impedance	ZIN		100		Ω	
Differential Data Input Swing	VIN,pp	180		900	mVp-p	
Receiver						
Output Differential Impedance	ZOUT		100		Ω	
Differential Data Input Swing	VOUT,pp	300		850	mVp-p	1

Notes:

1. Internally AC coupled but requires a external 100Ω differential load termination.

Optical Characteristics

Parameter	Symbol	Min.	Typ.	Max.	Unit	Notes
Transmitter						
Center Wavelength Range	λ_C	1304.5		1317.5	nm	
Side-Mode Suppression Ratio	SMSR	30			dB	
Average Launch Power Per Lane	P	-2.9		4	dBm	
Outer Optical Modulation Amplitude Per Lane	OMA _{outer}	-0.8		4.2	dBm	
Transmitter and Dispersion Penalty Eye Closure for PAM4 Per Lane	TDECQ			3.4	dB	
Launch Power in OMA _{outer} Minus TDECQ Per Lane (Minimum)		-2.2			dBm	
Extinction Ratio	ER	3.5			dB	
Average Launch Power of Off Transmitter	P _{off}			-15	dBm	
Optical Return Loss Tolerance	ORLT			21.4	dB	
Transmitter Reflectance				-26	dB	
Receiver						
Lane Wavelengths	Λ	1304.5		1317.5	nm	
Receiver Sensitivity Per Lane (OMA _{outer})				-4.4	dBm	1
Stressed Receiver Sensitivity (OMA _{outer}) Per Lane	OMA			-1.9	dBm	1
Receiver Overload (P _{avg})	POL	4			dBm	
Damage Threshold	POL	5			dBm	
Receive Power Per Lane (OMA _{outer})	OMA			4.2	dBm	
Receiver Reflectance	ORL			-26	dB	
LOS De-Assert	LOSD			-10	dBm	
LOS Assert	LOSA	-16			dBm	
LOS Hysteresis		0.5			dB	

Notes:

1. Measured with PRBS31Q test pattern @53.125GBd with PAM4 modulation and BER<2.4E⁻⁴.

Pin Descriptions

Pin	Symbol	Name/Description	Plug Sequence	Notes
1	GND	Transmitter Ground (Common with Receiver Ground).	1	1
2	Tx2-	Transmitter Inverted Data Input.	3	
3	Tx2+	Transmitter Non-Inverted Data Output.	3	
4	GND	Transmitter Ground (Common with Receiver Ground).	1	1
5	Tx4-	Transmitter Inverted Data Input.	3	
6	Tx4+	Transmitter Non-Inverted Data Output.	3	
7	GND	Transmitter Ground (Common with Receiver Ground).	1	1
8	ModSelL	Module Select.	3	
9	ResetL	Module Reset.	3	
10	VccRx	+3.3V Receiver Power Supply.	2	3
11	SCL	2-Wire Serial Interface Clock.	3	
12	SDA	2-Wire Serial Interface Data.	3	
13	GND	Transmitter Ground (Common with Receiver Ground).	1	1
14	Rx3+	Receiver Non-Inverted Data Output.	3	
15	Rx3-	Receiver Inverted Data Output.	3	
16	GND	Transmitter Ground (Common with Receiver Ground).	1	1
17	Rx1+	Receiver Non-Inverted Data Output.	3	
18	Rx1-	Receiver Inverted Data Output.	3	
19	GND	Transmitter Ground (Common with Receiver Ground).	1	1
20	GND	Transmitter Ground (Common with Receiver Ground).	1	1
21	Rx2-	Receiver Inverted Data Output.	3	
22	Rx2+	Receiver Non-Inverted Data Output.	3	
23	GND	Transmitter Ground (Common with Receiver Ground).	1	1
24	Rx4-	Receiver Inverted Data Output.	3	
25	Rx4+	Receiver Non-Inverted Data Output.	3	
26	GND	Transmitter Ground (Common with Receiver Ground).	1	1
27	ModPrsL	Module Present.	3	
28	IntL/RxLOS	Interrupt.	3	2
29	VccTx	+3.3V Transmitter Power Supply.	2	3
30	Vcc1	+3.3V Power Supply.	2	3
31	LPMoDe/TxDiS	Low-Power Mode.	3	
32	GND	Transmitter Ground (Common with Receiver Ground).	1	1
33	Tx3+	Transmitter Non-Inverted Data Input.	3	
34	Tx3-	Transmitter Inverted Data Output.	3	
35	GND	Transmitter Ground (Common with Receiver Ground).	1	1
36	Tx1+	Transmitter Non-Inverted Data Input.	3	
37	Tx1-	Transmitter Inverted Data Output.	3	
38	GND	Transmitter Ground (Common with Receiver Ground).	1	1

Notes:

1. QSFP112 uses common ground (GND) for all signals and supply (power). All are common within the QSFP DD module, and all module voltages are referenced to this potential unless otherwise noted. Connect these directly to the host board signal common ground plane. Each connector GND contact is rated for a maximum current of 500mA.
2. This is an open collector/drain output that, on the host board, requires a 4.7kΩ to 10kΩ pull-up resistor to the Host_Vcc.
3. VccRx, Vcc1, and VccTx shall be applied concurrently. For power classes 4 and above, the module differential loading of input voltage pads must not result in exceeding contact current limits. Each connector Vcc contact is rated for a maximum current of 1500mA.

Module Pad Layout

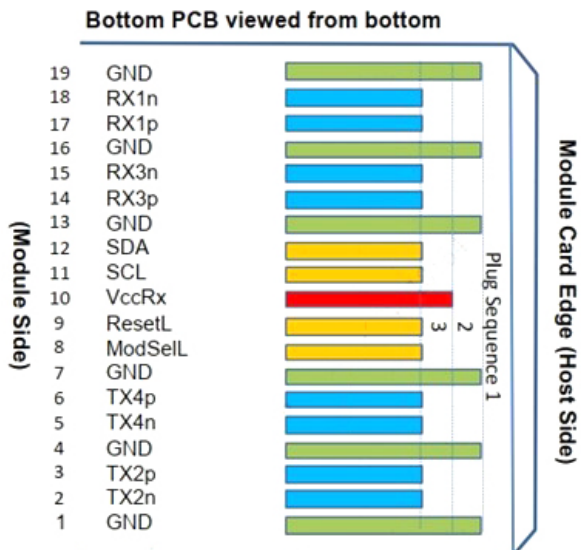
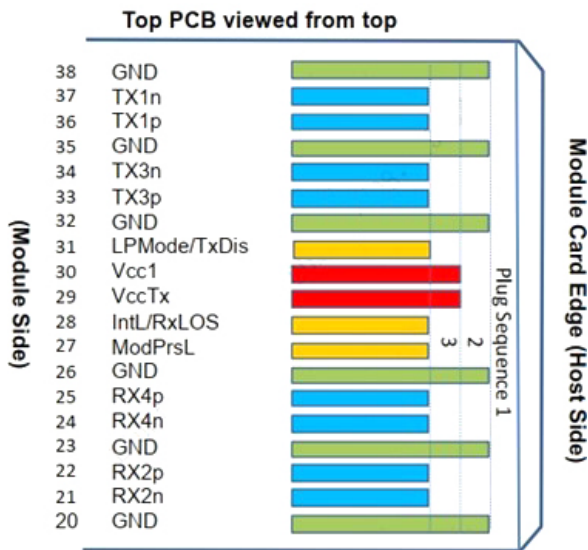

Recommended Host Board Power Supply Filter Network

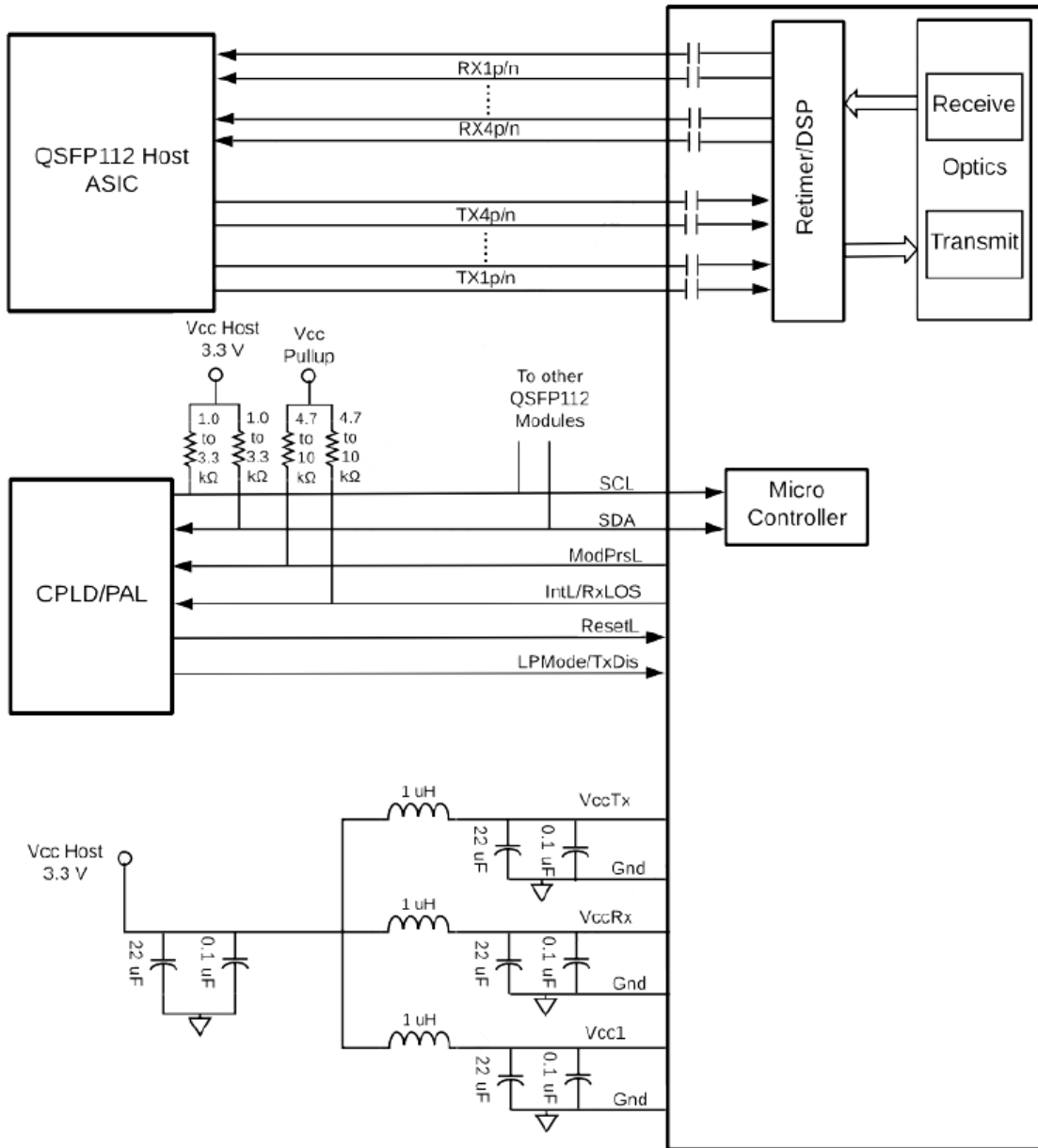

Mechanical Specifications

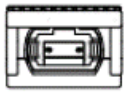

Unit:mm

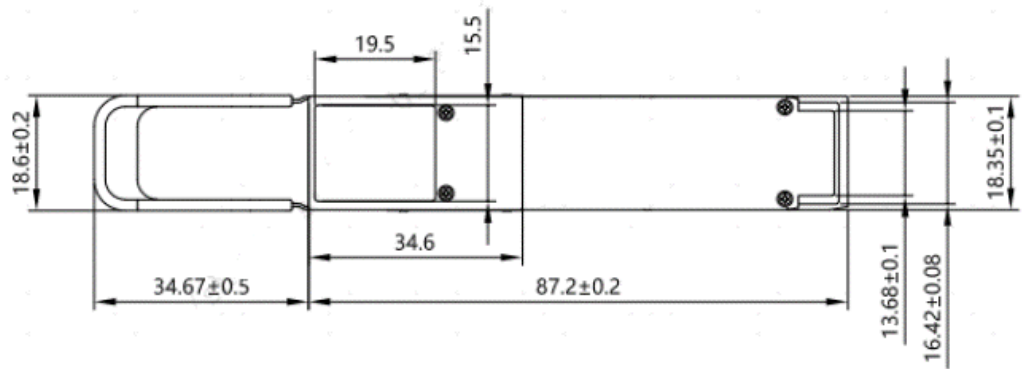
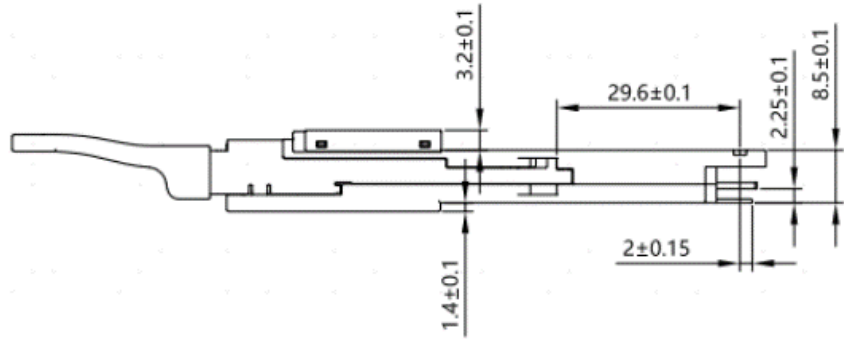
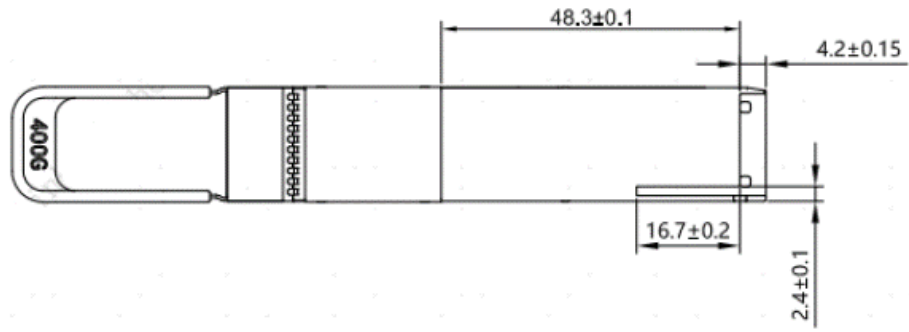

About AddOn Networks

In 1999, AddOn Networks entered the market with a single product. Our founders fulfilled a severe shortage for compatible, cost-effective optical transceivers that compete at the same performance levels as leading OEM manufacturers. Adhering to the idea of redefining service and product quality not previously had in the fiber optic networking industry, AddOn invested resources in solution design, production, fulfillment, and global support.

Combining one of the most extensive and stringent testing processes in the industry, an exceptional free tech support center, and a consistent roll-out of innovative technologies, AddOn has continually set industry standards of quality and reliability throughout its history.

Reliability is the cornerstone of any optical fiber network and is engrained in AddOn's DNA. It has played a key role in nurturing the long-term relationships developed over the years with customers. AddOn remains committed to exceeding industry standards with certifications from ranging from NEBS Level 3 to ISO 9001:2005 with every new development while maintaining the signature reliability of its products.



U.S. Headquarters

Email: sales@addonnetworks.com

Telephone: +1 877.292.1701

Fax: 949.266.9273

Europe Headquarters

Email: salesupportemea@addonnetworks.com

Telephone: +44 1285 842070