



# **SPEAKERS** FOR **COMMERCIAL INSTALLATIONS**

April 2022



1. High quality, richly musical sound
2. Visual design that harmonizes with any interior décor
3. Installation-friendly smart mechanical features

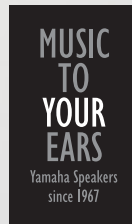

VXS, VXC, VC, VXL and VXH series speakers have been optimized specifically for commercial sound applications, with accurate sound inspired by our long history of musical instrument production plus visual design that blends easily with any décor. Choose the models that best suit your needs from our ample lineup.

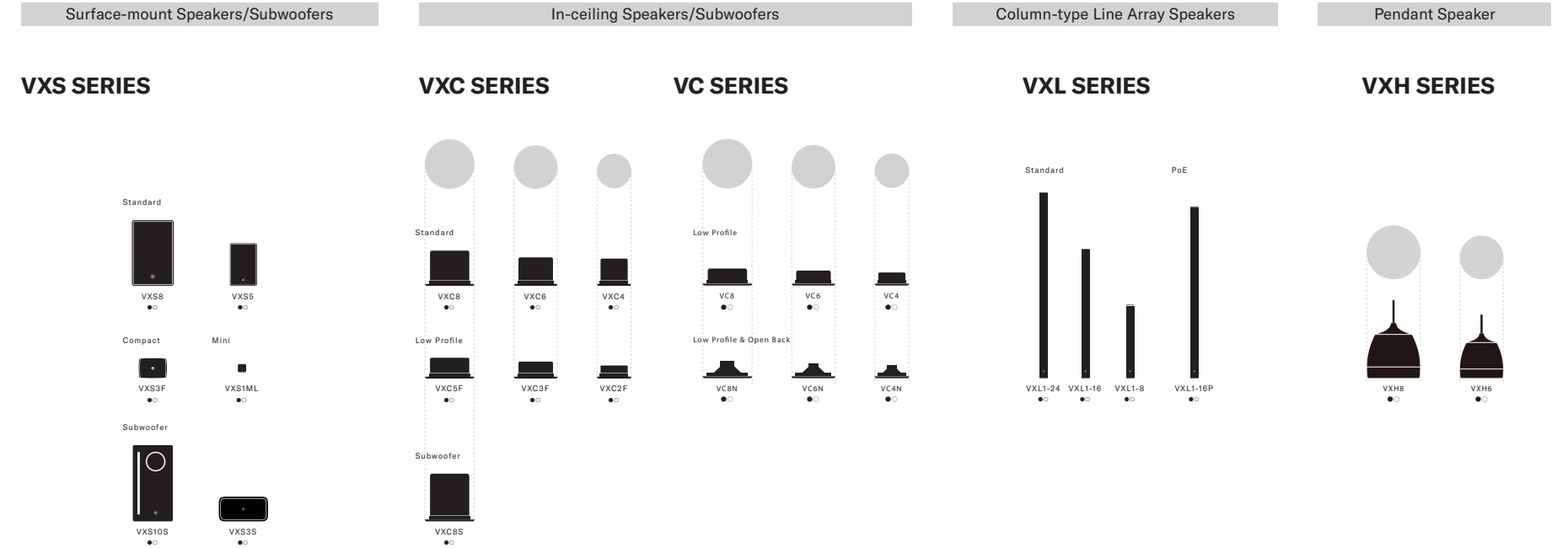

### Recommended Combinations

#### For Simple Sound Systems

- MA/PA Series

#### Recommended applications:

Cafes, restaurants, bars, retail stores, classrooms, presentation rooms, etc.



#### For Advanced Sound Systems

- MTX/MRX/XMV Series
- Controllers
- Peripherals

#### Recommended applications:

Conference rooms, lecture halls, restaurants, hotels, banquet halls, office complexes, multi-purpose facilities, shopping malls, etc.





# WHAT MAKES US APART

With such a prolific history of instrument manufacture comes a unique musical sensibility that deeply influences all our speaker lineups. We won't settle for anything less than truly authentic, superior sound that satisfies the most discriminating tastes.



# SOUND

We've adopted a uniquely utilitarian approach to speaker design that derives its aesthetic from the functionality of the speaker's construction so that every curve and corner serves a purpose that will ultimately benefit our customers and their clientele— with style.

# DESIGN



Our meticulous parts and material selection process and innovative proprietary technologies ensure the same level of durability and reliability as our acclaimed professional audio gear and masterfully crafted musical instruments.

# QUALITY





**“It** is very important for us to put the focus beyond fantastic food and great service. We do a lot of planning of the details, even for the people who just want to come down to the bar for a drink and a game of shuffleboard after work,” says Usine Group booking manager Emilia Tuomela.

“To make you feel at home and in the right mood for good food and good company whenever you visit, we vary the music according to the time of day.

“If you are ever in Södermalm, whether it is sunny or snowing, we will give you a warm welcome.”



**Restaurant “Usine,” in Stockholm, Sweden**

# M A K E

# I M P R E S S I O N S

Just like lighting, aroma, and interior design, the sounds a customer is initially exposed to can have a significant impact on their comfort and enthusiasm for your business.

Creating an inviting, high-quality sonic environment will not only complement your other stylistic choices, but influence per-customer spending and repeat business.

Yamaha is invested in the creative choices you make with your space by providing state-of-the-art products with superb musicality that ensure your vision resonates with everyone who enters.



**“We** don’t aim to be high class and exclusive, my vision of the restaurant is of a tavern in a fishing village. My passion is for good, tasty food, good wine and good company,” says Gaku Takahashi at St Pierre.

“As soon as we tried them, it was clear that just two of the tiny VXS1MLs would provide plenty of volume and the audio quality was outstanding!”

**Restaurant “St Pierre,” in Tokyo, Japan**



**“We’re** not just a reseller, we consider ourselves part of a community. We hold camping events around the world to inspire people to enjoy the outdoors and anyone is welcome to drop in here for a chat with the staff or a snack in our cafe without feeling obliged to buy anything,” says General Manager Gunnar Björling.

“Through the architecture, the soundtrack, our products and our team of outdoor enthusiasts at Snow Peak St James’s, we want to inspire a new type of outdoor adventure and help people to reconnect with the natural world and the rest of mankind. Because to us there’s no greater luxury than spending time in nature.”

**Retail Store “Snow Peak St. James” in London, the United Kingdom**



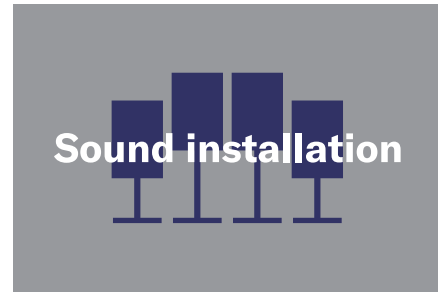

Photograph by Alta Lumina / Moment Factory  
ALTA LUMINA (Installation, FR)



Team Lab Borderless (Installation, JP)



ACMI (Installation, AU)



ITOKI (Office, JP)



Young Capital (Office, Netherlands)



Airbus learning center (Office, FR)



Photograph by Grand Plaza Movenpick Media City Dubai  
Grand Plaza Movenpick Media City (Hospitality, UAE)



Mitsui Garden Hotel (Hotel, Japan)



InterContinental Hotel (Hotel, Switzerland)



INHA (Education, Uzbekistan)



Photograph by Laith Al-Badareen  
Qatar University Event & Sports Center (Education, Qatar)



Royal Academy of Music (Education, UK)



La Maison du Sake (Restaurant, France)



Pizza 800 degree (Hospitality, JP)

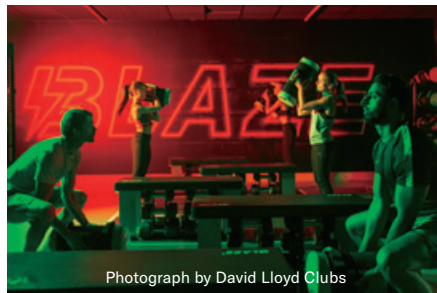

Photograph by David Lloyd Clubs  
Fitness Blaze (Fitness, UK)



Thermes Marins Monte-Carlo (Spa, Monaco)



Eglise Saint-Denis-Sainte-Foy (Church, France)



Moscow church (HOW, RU)



Saint Panteleimon Monastery (HOW, Greek)



Volvo Studio Aoyama (Showroom, Japan)



Shang Xia (Boutique, China)



Hill's Avenue (Retail, JP)



Billund Airport (Airport, Denmark)



Stone Harbor Municipal Courthouse (Courthouse, USA)

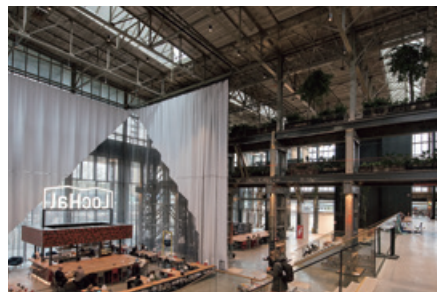

Lachal community center (Government, Netherlands)



### Attractive, Discreet Design for Elegant Spaces

It is our goal to offer the most pleasing environments possible, both sonically and visually. The sleek curves and attractive, minimalist design of VXS series make them easily adaptable to any commercial environment seeking a unique, subtle complement to the overall aesthetic.



### Safe and Efficient Installation

The brackets supplied with the VXS series are all you need for smooth, streamlined wall or ceiling mounting. The bracket itself is a compact design that facilitates mounting in tight spaces, while incorporating features for safe, efficient installation.

#### VXS8/VXS5



A press-in bracket design leaves both hands free for easy wiring and angle adjustment.



Reverse-thread screws and safety pin prevent damage or injury due to the speaker accidentally falling during installation.



A design that prevents lateral movement during ceiling installation simplifies vertical angle adjustment.

#### VXS1ML

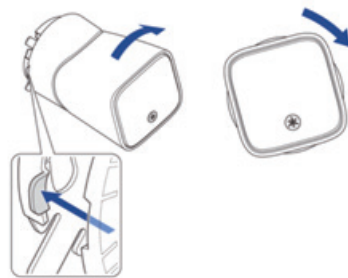

Align the speaker to the notch on the mounting bracket, and then attach the speaker. Secure the speaker by turning it clockwise.

### Featured Model



Bigger isn't always better, and for more intimate commercial environments in particular, a subtle approach to the sights and sounds your customers experience can often leave a stronger impression. Yamaha's ultra-compact VXS1ML provides an attractive interior accent, while filling your space with music that helps shape your overall aesthetic and inspires your clientele.

#### Blending into Any Décor

A remarkably small cube with elegantly flowing lines and surfaces.



#### Room-filling Sound Experience

Carefully selected and tuned 1.5" driver with neodymium magnet, realizing wide coverage.



#### Installation Friendly

Wall-mount, ceiling mount, In-ceiling\*, or hanging from lighting rail\*.

\*with optional accessories

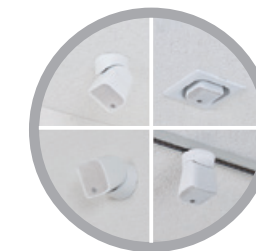

### Recommended Subwoofer: VXS3S

In situations where more substantial low end is required, the compact VXS3S subwoofer is a perfect match for the VXS1ML. Featuring unique SR-Bass™ technology, the VXS3S delivers impactful bass performance while reducing the enclosure size.



+



VXS3S

### Tips for System Design & Installation

#### Speaker Layout

The coverage area of surface-mount speakers will depend on the mounting height rather than ceiling height. With surface-mount speakers installed at a height of around 3 meters, the coverage area will be somewhere between 5 and 7 meters, as shown in the below figure.

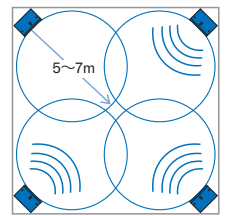

Speaker mounting position: around 3m height

Higher speaker mounting positions will result in larger coverage circles: between 1 and 2 meters increase in diameter for every 1 meter in height, approximately.

Uniform sound pressure level can easily be achieved throughout the listening plane with speakers that include by aligning the speaker's axis with the head of the most distant target (listener). This works because of the relationship between distance and coverage angle. When the perpendicular axis is aligned with the last row, the natural distance attenuation at the last row and the off-axis attenuation at closer rows tend to result in uniform SPL distribution.

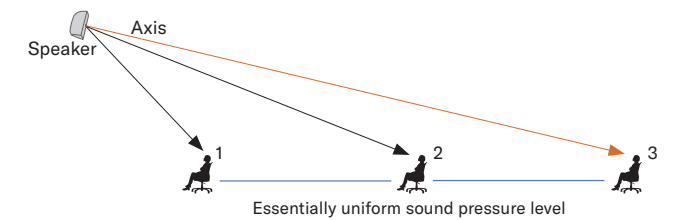

\*Yamaha provides dedicated speaker software application CISSCA for designing simple installation such as in-store background music system. Please see page 12 for the details.

#### Satellite Connection

The VXS10S/VXS3S subwoofers have satellite connectors on the rear panel, minimizing the number of amplifier channels required to get a system up and running. And since the subwoofers support high-impedance connections, it is possible to connect low-impedance satellite speakers while the subwoofer is connected to a high-impedance system. A built-in high-pass filter is automatically applied to the satellite speakers, providing exceptionally smooth, natural frequency crossover from subwoofer to satellites.

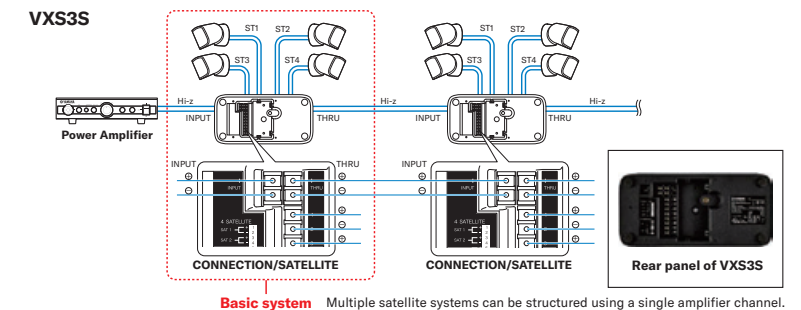

Surface-mount Speakers/Subwoofers

# VXS SERIES

Standard



VXS8



VXS5

Compact



VXS3F

Mini



VXS1ML

Subwoofer



VXS10S



VXS3S

Recommended for  
**Background Music System**

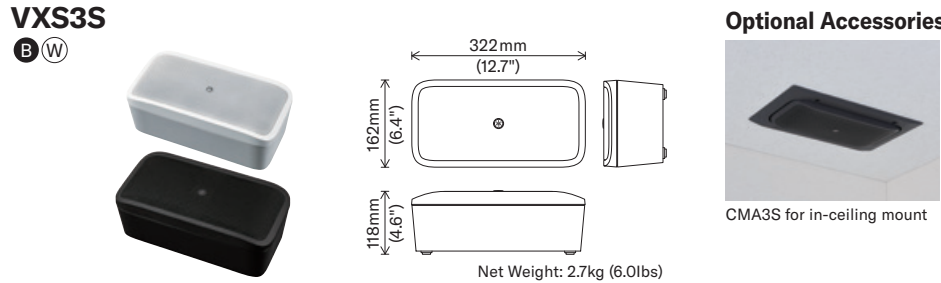
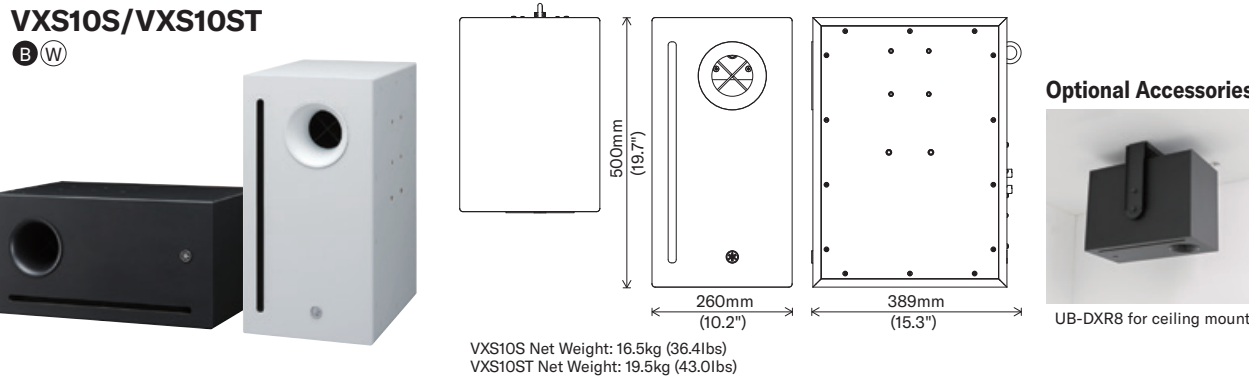
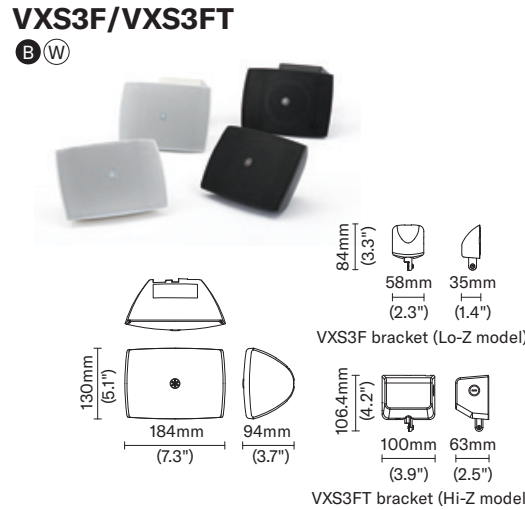
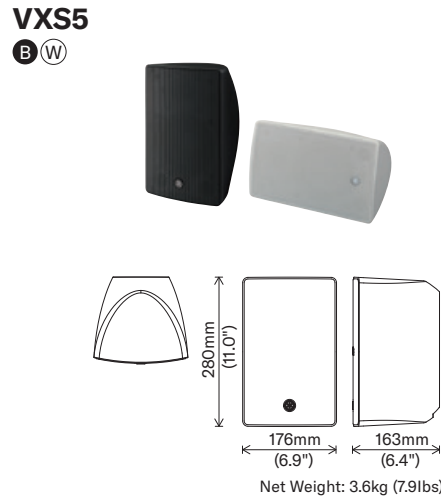
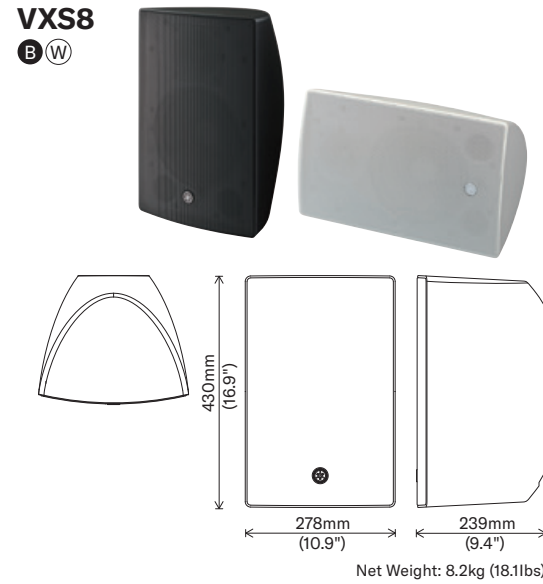

\*Dedicated mounting bracket is included in each model.

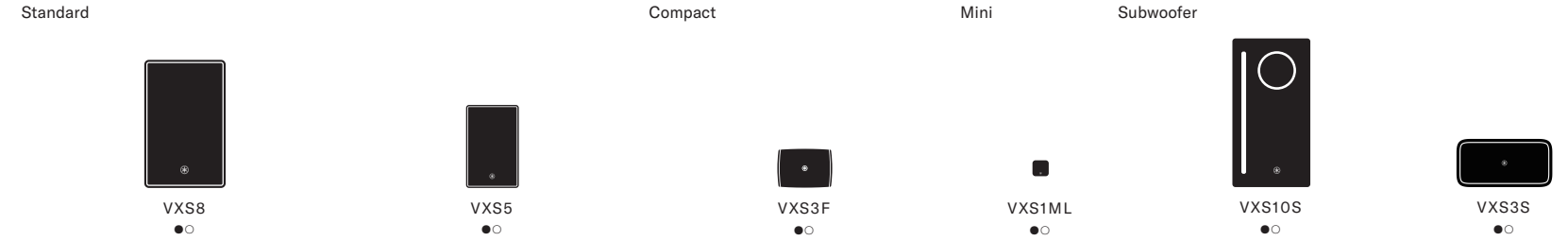

VXS series	VXS8/VXS8W	VA version* (EN54-24 model)	VXS5/VXS5W	VA version* (EN54-24 model)	VXS3F/VXS3FW	VXS3FT/VXS3FTW	VXS1MLB/VXS1MLW	VXS10S/VXS10SW	VXS10ST/VXS10STW	VXS3SB/VXS3SW	
Speaker type	2-way, Bass reflex		2-way, Bass reflex		Full-range, Acoustic suspension		Full-range, Acoustic suspension		Subwoofer, Bass reflex		
Components	LF 8", HF 1"		5.25", 0.75"		3.5"		1.5"		10" Dual Voice Coil		
Crossover frequency	2.8kHz		3kHz		-		-		-		
Frequency range (-10dB)	51Hz - 20kHz		62Hz - 20kHz		130Hz - 20kHz		180Hz - 20kHz		45Hz - 250Hz		
Nominal coverage (Horizontal x Vertical)	H100° x V100°		H120° x V120°		H150° x V160°		H170° x V170°		-		
Power rating	NOISE	90W	75W	75W	20W	-	5W	100W + 100W	-	20W	
	PGM	180W	150W	150W	40W	-	10W	200W + 200W	-	40W	
	PEAK	360W	300W	300W	80W	-	20W	400W + 400W	-	80W	
Nominal impedance	8Ω		8Ω		8Ω		8Ω		8Ω + 8Ω		
Transformer taps	100V	60W, 30W, 15W	30W, 15W, 7.5W	30W, 15W, 7.5W	-	15W, 7.5W, 3.8W	-	-	200W, 100W, 50W	15W, 7.5W, 3.8W	
	70V	60W, 30W, 15W, 7.5W	30W, 15W, 7.5W, 3.8W	30W, 15W, 7.5W, 3.8W	-	15W, 7.5W, 3.8W, 1.9W	-	-	200W, 100W, 50W, 25W	15W, 7.5W, 3.8W, 1.9W	
SPL	Sensitivity (1W, 1m)	91dB SPL (Half-space)	89dB SPL (Full-space)	89dB SPL (Half-space)	88dB SPL (Full-space)	86dB SPL (Full-space)		79dB SPL (Full-space)	96dB SPL (Half-space)		
	Peak (Calculated, 1m)	117dB SPL	115dB SPL	114dB SPL	113dB SPL	105dB SPL	-	92dB SPL	125dB SPL	98dB SPL	
Satellite filter	-	-	-	-	-	-	-	-	Network filter: HPF 200Hz, 6dB/OCT		
Satellite impedance	-	-	-	-	-	-	-	-	8Ω load per satellite output recommended		
I/O connectors	Euroblock (4 pin)		Ceramic terminal block	Euroblock (4 pin)	Ceramic terminal block	Euroblock (4 pin)	Barrier strip	Euroblock (2 pin)	Input: Euroblock (4 pin)	Input: Barrier strip	
									Satellite out: Euroblock (4 pin)	Satellite out: Barrier strip	
Magnetically shielded	No										
Overload protection	Full-range power limiting to protect network and transducers										
Enclosure material	Cabinet	ABS (UL94 V-0)	ABS (UL94 5VB)	ABS (UL94 V-0)	ABS (UL94 5VB)	ABS (UL94 5VB)	ABS (UL94 V-0)	MDF	ABS (UL94 V-0)	ABS (UL94 V-0)	
	Baffle	PC/ASA	ABS (UL94 5VB)	PC/ASA	ABS (UL94 5VB)	ABS (UL94 5VB)	ABS (UL94 V-0)	-	ABS (UL94 V-0)	ABS (UL94 V-0)	
Grille material	Powder coated perforated aluminum					Powder coated perforated steel					
Finish	Black model	Munsell N3/RAL 9017 (approx.)					Munsell N3/RAL 9017 (approx.)				
	White model	Munsell N9.3/RAL9010 (approx.)					Munsell N9/RAL9010 (approx.)				
Dust and water resistance (IP rating)	IP35**		IP35**		-		-		-		
Dimensions	W278mm (10.9") x H430mm (16.9") x D239mm (9.4")		W176mm (6.9") x H280mm (11.0") x D163mm (6.4")		W184mm (7.3") x H130mm (5.1") x D94mm (3.7")		W62mm (2.4") x H82mm (3.2") x D62mm (2.4")		W260mm (10.2") x H500mm (19.7") x D389mm (15.3")		
Net weight	8.2kg (18.1lbs)		3.6kg (7.9lbs)		1.1kg (2.4lbs)		1.7kg (3.7lbs)		0.17kg (0.37lbs)		
Packaging	Pair	Pair	Pair	Pair	Pair	Pair	Single	Single	Single	Single	
Certificate	UL1480, NFPA70, CE, EAC, RoHS	EN54-24, CE, RoHS	UL1480, NFPA70, CE, EAC, RoHS	EN54-24, CE, RoHS	UL1480, NFPA70, CE, EAC, RoHS	UL1480, NFPA70, CE, EAC, RoHS	UL1480, NFPA70, CE, EAC, RoHS	CE, EAC, RoHS	CE, EAC, RoHS	UL1480, NFPA70, CE, EAC, RoHS	
EN54-24 DoP number	-	0359-CPR-00406	-	0359-CPR-00406	-	-	-	-	-	-	

\* VA versions are not available in some regions.  
\*\* IP34 when installing the speaker to the ceiling vertically.

In-ceiling Speakers/Subwoofers

# VXC SERIES

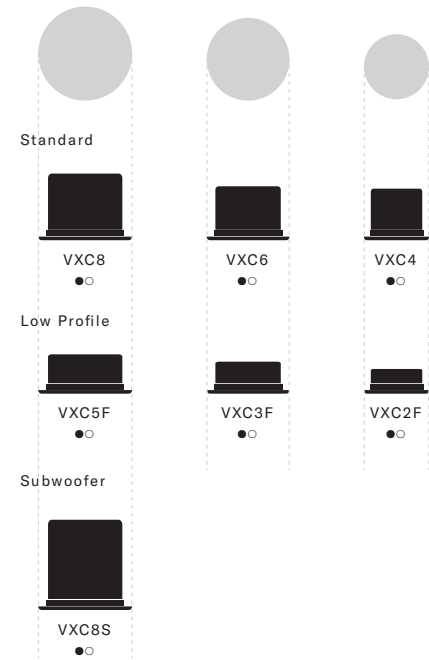

Recommended for  
**Background Music System**

## Smart Design for Safer, Faster Installation

The VXC ceiling speakers come with smart mechanical features that contribute to significantly safer, faster installation. And since these models support both low-impedance and high-impedance connection, the need for extra stock is minimized and systems can be designed to ideally meet the requirements of any application.

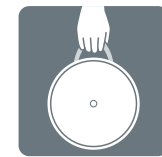

**Portable**  
A built-in "Carrying Band" not only makes the speaker easy to carry around, but also increases safety when working on a stepladder.



**Fast**  
Double threaded screws used for the speaker clamp mechanism allow the clamps to be tightened twice as fast as conventional screws.

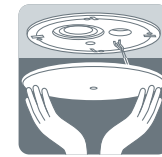

**Streamlined**  
The supplied speaker grilles are firmly and elegantly held in place by powerful magnets. An anti-drop wire is also included.



**Secure**  
An "Anti-Drop Tab" mechanism securely holds the speaker in place so that the installation can proceed safely and efficiently. There's also a release lever that allows the speaker to be smoothly removed from the ceiling as required.

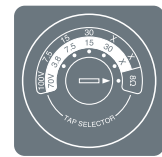

**Hi-Z or Lo-Z**  
Both high-impedance and low-impedance connections are supported, and speaker wattage can be easily switched even after installation.



**Paintable**  
The supplied grilles can be painted any color to match interior decor.

### Carrying Band



### Anti-Drop Tab



## Featured Model

### Style and Substance.

Low-profile In-ceiling Speaker  
**VXC2F** (VXC Series F)

Featuring a newly designed speaker driver unit, optimally tuned for music playback, the VXC2F's super slim, lightweight construction and flexible design can easily adapt to the strictest installation limitations, ensuring superb audio performance wherever they're placed. It allows you to streamline the installation process and seamlessly integrate high-quality audio into a restaurant, retail, or professional environment, which proves that style and substance aren't always mutually exclusive.

### Super Slim Back Can

A back can less than 76.2mm/3 inches deep, which directly contributes to flexible installation.

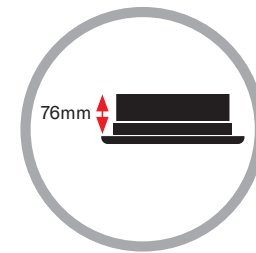

### Recommended Subwoofer: VXC8S

Yamaha also offers an in-ceiling subwoofer that ideally matches for VXC series speakers, smoothly extending the low frequency range with superb sonic quality without spoiling interior design.



### Streamlined Design

Grilles with minimum rim width, available in black or white, and removable logo.



### Pendant-mount Option

Suspension hardware and loudspeaker cosmetic cover designed for hanging from open ceilings.



## Tips for System Design & Installation

### Speaker Layout

It is important to note that the nominal coverage angle listed in ceiling speaker specifications is not the same as the speaker's actual effective coverage angle. SPL at the nominal coverage angle is 6dB lower than the on-axis SPL, measured at a constant distance from the speaker. The effective coverage angle is defined as the angle at which the SPL is 6dB lower than the on-axis SPL at the listening plane. The effective coverage angle is usually about 70~80% of the nominal coverage angle.

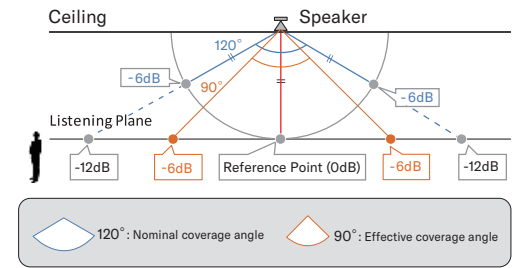

A number of methods can be employed when laying out speaker coverage areas. The "Edge to Edge" method is normally used for background music systems. The chart lists approximate coverage areas at a number of ceiling heights for standing listeners (listener ear height = around 1.5 meters). If the ceiling height is 3 meters, the coverage area will be approximately 4 meters. In this case a ceiling speaker spacing of 4 meters will provide uniform coverage with minimal volume variation.

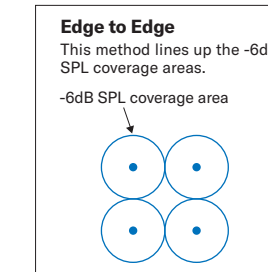

Ceiling height	2.5m	3.0m	3.5m	4.0m	4.5m
Ceiling speaker spacing	3.0m	4.0m	5.0m	6.0m	7.0m

### CISSCA

CISSCA, the Commercial Installation Solutions Speaker Calculator, is a Yamaha's dedicated software application that rapidly calculates the number of speakers required for optimum performance in installations, based on the size of the room, type of system, type of speakers, and speaker layout pattern. Output also includes an estimate of effective sound pressure level. CISSCA also has a "Report" function that makes it easy to create documentation. Downloadable from Yamaha website for free.

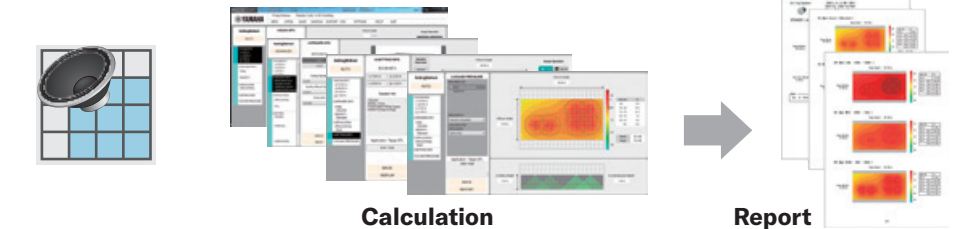

Calculation

Report



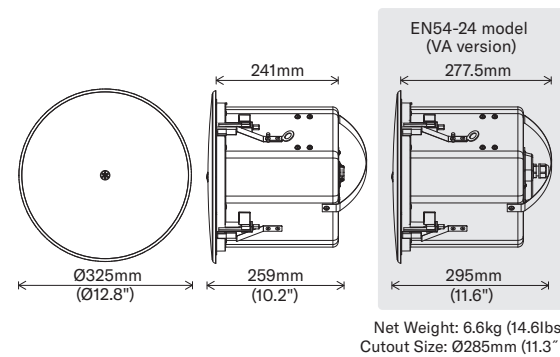

Net Weight: 6.6kg (14.6lbs)  
Cutout Size: Ø285mm (11.3")

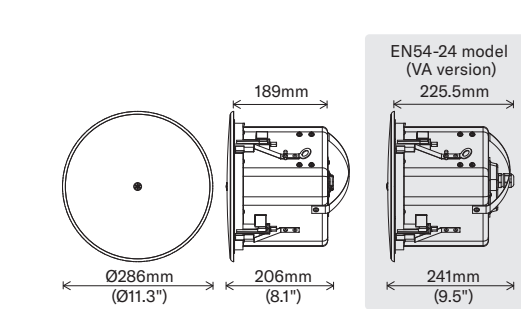

Net Weight: 4.4kg (9.7lbs)  
Cutout Size: Ø247mm (9.8")

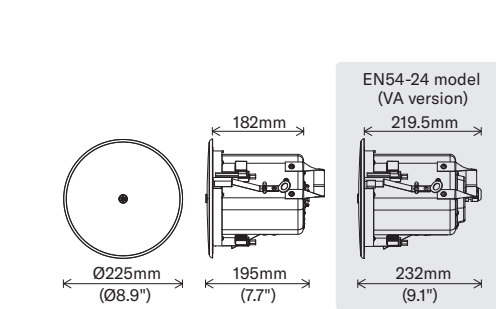

Net Weight: 2.6kg (5.7lbs)  
Cutout Size: Ø186mm (7.3")

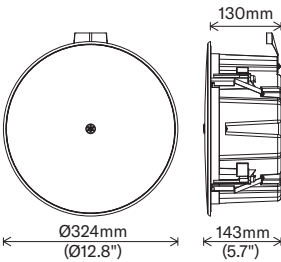

Weight: 3.1kg (6.8lbs)  
Cutout Size: Ø285mm (11.3")

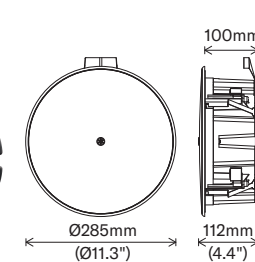

Net Weight: 2.5kg (5.5lbs)  
Cutout Size: Ø247mm (9.8")

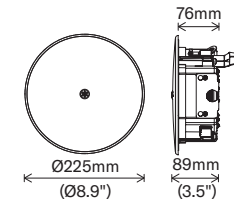

Net Weight: 1.7kg (3.7lbs)  
Cutout Size: Ø186mm (7.3")

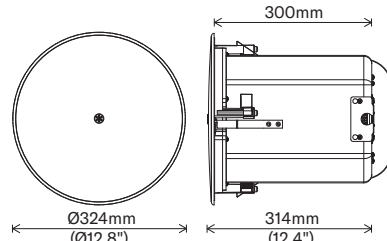

Net Weight: 8.7kg (19.2lbs)  
Cutout Size: Ø285mm (11.3")

### Optional Accessories

#### PK-C4

Pendant-mount kit for VXC4/VXC2F



#### AB-C2 / AB-C8S\*

Tile rail kit for VXC2F/VXC8S



\*Tile rail kit is included in all models except VXC2F/VXC8S.

Standard

Low Profile

Subwoofer



VXC series	VXC8/VXC8W		VXC6/VXC6W		VXC4/VXC4W		VXC5F/VXC5FW		VXC3F/VXC3FW		VXC2FB/VXC2FW	VXC8SB/VXC8SW
	VA version* (EN54-24 model)		VA version* (EN54-24 model)		VA version* (EN54-24 model)		VA version* (EN54-24 model)		VA version* (EN54-24 model)			
Speaker type	2-way, Acoustic suspension		2-way, Acoustic suspension		Full-range, Bass reflex		Full-range, Bass reflex		Full-range, Bass reflex		Full-range, Bass reflex	Subwoofer, Band pass
Components	LF 8", HF 1"		LF 6.5", HF 0.75"		4"		4.5"		3.5"		2.5"	8"
Crossover frequency	3kHz		3.2kHz		-		-		-		-	-
Frequency range (-10dB)	55Hz - 20kHz		56Hz - 20kHz		80Hz - 20kHz		60Hz - 20kHz		71Hz - 20kHz		67Hz - 20kHz	44Hz - 200Hz
Nominal coverage (Conical)	100°		110°		130°		130°		140°		160°	-
Power rating	NOISE 90W, PGM 180W, PEAK 360W		NOISE 75W, PGM 150W, PEAK 300W		NOISE 30W, PGM 60W, PEAK 120W		NOISE 40W, PGM 80W, PEAK 160W		NOISE 20W, PGM 40W, PEAK 80W		NOISE 15W, PGM 30W, PEAK 60W	NOISE 15W, PGM 30W, PEAK 60W
Nominal impedance	8Ω		8Ω		8Ω		8Ω		8Ω		8Ω	8Ω
Transformer taps	100V: 60W, 30W, 15W; 70V: 60W, 30W, 15W, 7.5W		100V: 60W, 30W, 15W; 70V: 60W, 30W, 15W, 7.5W		100V: 30W, 15W, 7.5W; 70V: 30W, 15W, 7.5W, 3.8W		100V: 30W, 15W, 7.5W; 70V: 30W, 15W, 7.5W, 3.8W		100V: 15W, 7.5W, 3.8W; 70V: 15W, 7.5W, 3.8W, 1.9W		100V: 15W, 7.5W, 3.8W, 1.9W; 70V: 15W, 7.5W, 3.8W, 1.9W, 1W	100V: 60W, 30W, 15W, 7.5W; 70V: 60W, 30W, 15W, 7.5W, 3.8W
SPL	Sensitivity (1W, 1m): 90dB SPL (Half-space), Peak (Calculated, 1m): 116dB SPL		Sensitivity (1W, 1m): 89dB SPL (Half-space), Peak (Calculated, 1m): 114dB SPL		Sensitivity (1W, 1m): 86dB SPL (Half-space), Peak (Calculated, 1m): 111dB SPL		Sensitivity (1W, 1m): 87dB SPL (Half-space), Peak (Calculated, 1m): 108dB SPL		Sensitivity (1W, 1m): 89dB SPL (Half-space), Peak (Calculated, 1m): 111dB SPL		Sensitivity (1W, 1m): 87dB SPL (Half-space), Peak (Calculated, 1m): 106dB SPL	Sensitivity (1W, 1m): 86dB SPL (Half-space), Peak (Calculated, 1m): 105dB SPL
I/O connectors	Euroblock (4 pin), Ceramic terminal block		Euroblock (4 pin), Ceramic terminal block		Euroblock (4 pin), Ceramic terminal block		Euroblock (4 pin), Ceramic terminal block		Euroblock (4 pin), Ceramic terminal block		Euroblock (4 pin)	Euroblock (4 pin)
Magnetically shielded	No											
Overload protection	Full-range power limiting to protect network and transducers											
Enclosure material	Cabinet (Back Can): Steel, Baffle: HIPS		Cabinet (Back Can): Steel, Baffle: HIPS		Cabinet (Back Can): Steel, Baffle: HIPS		Cabinet (Back Can): ABS (UL94 V-0), Baffle: ABS (UL94 V-0)		Cabinet (Back Can): ABS (UL94 V-0), Baffle: ABS (UL94 V-0)		Cabinet (Back Can): Steel, Baffle: ABS (UL94 V-0)	Cabinet (Back Can): Steel, Baffle: ABS (UL94 V-0)
Grille material	Powder coated perforated steel/Trim-ring: ABS (UL94 V-0)											
Finish	Black model: Munsell N3/RAL 9017 (approx.), White model: Munsell N9.3/RAL9010 (approx.)		Black model: Munsell N3/RAL 9017 (approx.), White model: Munsell N9.3/RAL9010 (approx.)		Black model: Munsell N3/RAL 9017 (approx.), White model: Munsell N9.3/RAL9010 (approx.)		Black model: Munsell N3/RAL 9017 (approx.), White model: Munsell N9.3/RAL9010 (approx.)		Black model: Munsell N3/RAL 9017 (approx.), White model: Munsell N9.3/RAL9010 (approx.)		Black model: Munsell N3/RAL 9017 (approx.), White model: Munsell N9.3/RAL9010 (approx.)	Black model: Munsell N3/RAL 9017 (approx.), White model: Munsell N9.3/RAL9010 (approx.)
Dust and water resistance (IP rating)	-		IP32		-		IP32		-		IP32	
Dimensions	Ø325mm (12.8") x D259mm (10.2")		Ø286mm (11.3") x D206mm (8.1")		Ø225mm (8.9") x D195mm (7.7")		Ø225mm (8.9") x D232mm (9.1")		Ø324mm (12.8") x D143mm (5.7")		Ø285mm (11.3") x D112mm (4.4")	Ø225mm (8.9") x D89mm (3.5")
Net weight	6.6kg (14.6lbs)		4.4kg (9.7lbs)		2.6kg (5.7lbs)		2.6kg (5.7lbs)		3.1kg (6.8lbs)		2.5kg (5.5lbs)	1.7kg (3.7lbs)
Packaging	Pair		Pair		Pair		Pair		Pair		Pair	Single
Certificate	UL1480, UL2043, NFPA70, CE, EAC, RoHS		EN54-24, CE, RoHS		UL1480, UL2043, NFPA70, CE, EAC, RoHS		EN54-24, CE, RoHS		UL1480, UL2043, NFPA70, CE, EAC, RoHS		EN54-24, CE, RoHS	UL1480, UL2043, NFPA70, CE, EAC, RoHS
EN54-24 DoP number	-		0359-CPR-00405		-		0359-CPR-00405		-		0560-CPR-152190027	0560-CPR-152190028

\* VA versions are not available in some regions.  
\*\* Specifications of the VXC2F and VXC8S are tentative.



Column-type Line Array Speakers

# VXL SERIES

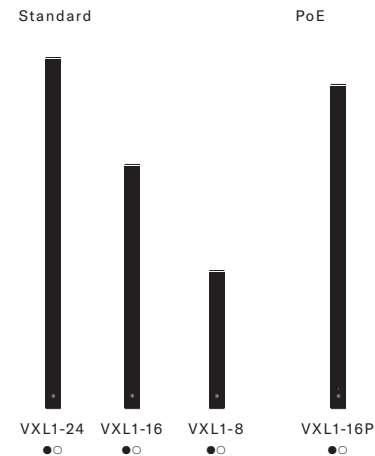

Recommended for  
**Speech / Presentation System**



**Sleek. Smart. Sound.**

## Blending Quality Sound with Visual Elegance

Ultra slim 54mm width appearance thanks to the small 1.5" driver shared with VXS1ML yet redesigned with a large voice coil, delivering distortion-free sound over a broad band of playback frequencies.

54mm



## Outstanding Projection and Clear Sound Reinforcement

A line-array configuration significantly reduces the amount of reflection at the ceiling and floor surfaces, which means sound pressure is affected less by distance. As a result, clearer, more consistent sound can be delivered to back-of-house without making front-of-stage excessively loud.

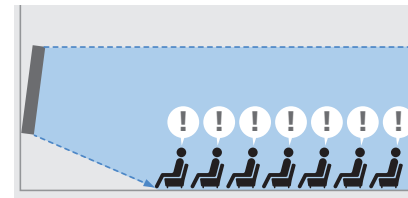

## Less Feedback Noise

With line-array speakers the per-unit output is smaller than with point-source speakers, meaning that a microphone positioned nearby picks up less sound energy.



## Tips for System Design & Installation

### Vertical Coverage Expansion

The VXL1-16 and VXL1-24 feature special rear-panel switches that allow the lower vertical dispersion of the array to be easily expanded without having the angled speakers. This improves coverage at the front of the listening area in situations where the speakers are installed at a high location.

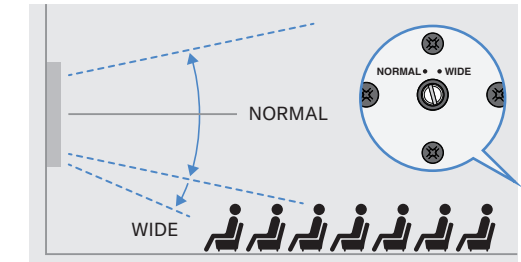

\*VXL1-8's vertical dispersion is fixed

### Double Speakers

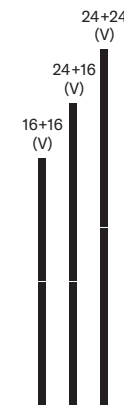

#### Vertical Coupling

For increased SPL and extra projection.

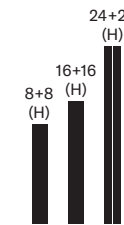

#### Horizontal Coupling

For increased SPL and more focused coverage that can minimize unwanted reflections from nearby surfaces.

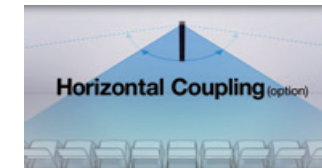

### Dante + PoE Solution (VXL1-16P)

With audio distributed via a Dante network and PoE power supplied from a PoE compliant L2 switch, the speaker system can be constructed as a network. Simple wiring via LAN cables, easy installation, and no need for a power amp contribute to the flexibility of installation, allowing you to construct an elegant space-saving sound system.

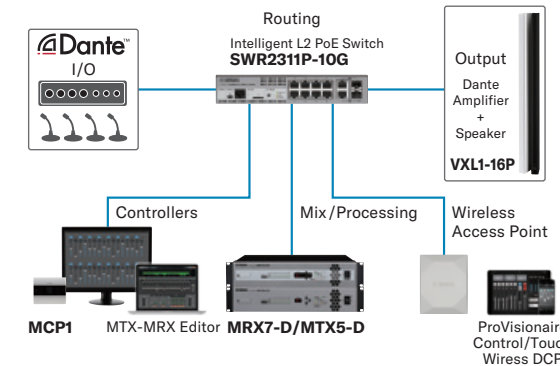

### VXL Selection Assistant

VXL Selection Assistant is a dedicated app available for free on Yamaha website, which is intended to assist the selection of the most appropriate VXL speaker model for speech reproduction applications. The App will provide an indication of whether good amplified sound can be provided across the audience area by calculating the difference in SPL between the nearest and furthest audience members. Good amplified sound can be expected if the SPL range across the audience area is within 10 dB.

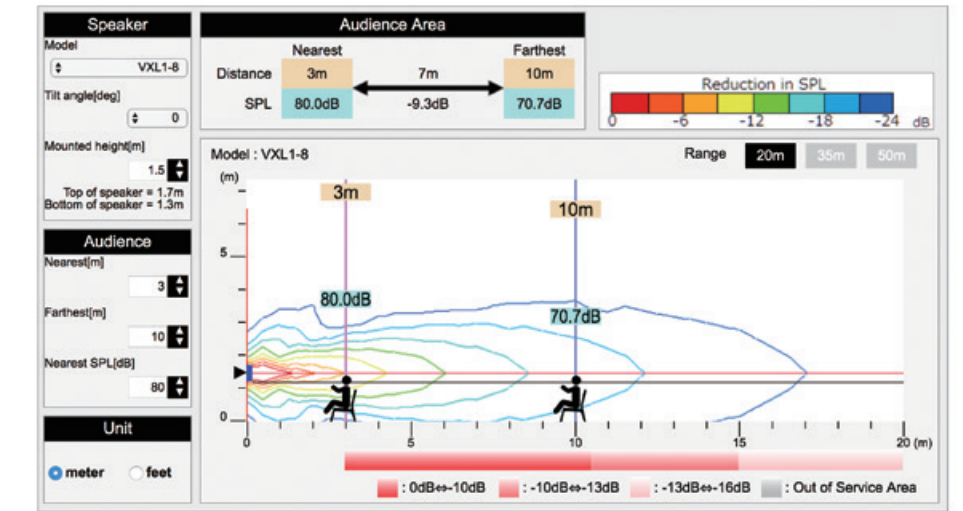

The following shows a quick reference guide for appropriate selection of the VXL series.

	Distance D
VXL1-8	9.5m (31 feet)
VXL1-16	13.5m (44 feet)
VXL1-24	25m (82 feet)

\*Distance from the speaker to the nearest audience: 3m  
\*Distance from the floor to the bottom of the speaker: 1.1m

For much larger space, the use of double speakers in vertical coupling is recommended.

	Distance D
VXL1-16 + VXL1-16	33m (108 feet)
VXL1-24 + VXL1-16	42m (138 feet)
VXL1-24 + VXL1-24	46m (151 feet)

\*Distance from the speaker to the nearest audience: 4m  
\*Distance from the floor to the bottom of the speaker: 1.1m

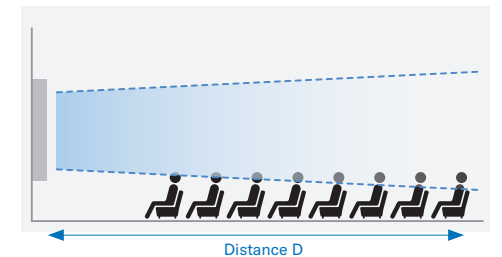

D: Distance from the speaker to the farthest audience\*

\*The SPL difference between the nearest and the farthest is within 10dB SPL.



**VXLI-24**  
B W

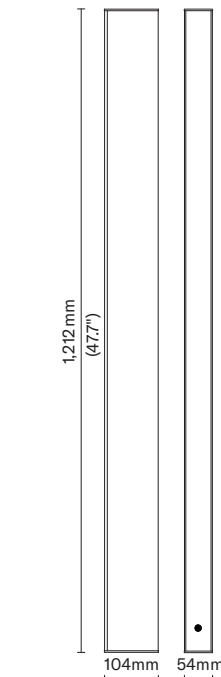

Net Weight: 5.5kg (12.1lbs)

**VXLI-16**  
B W



Net Weight: 3.9kg (8.6lbs)

**VXLI-8**  
B W

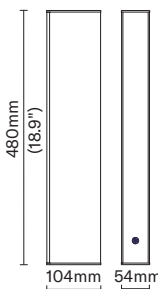

Net Weight: 2.1kg (4.6lbs)

\*Dedicated mounting bracket is included in each model.

**VXLI-16P**  
B W

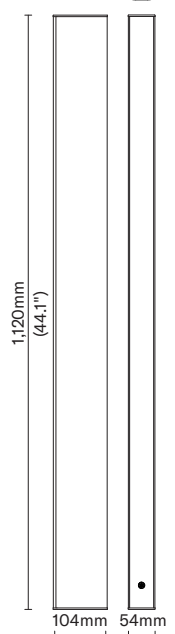

Net Weight: 5kg (11.0lbs)

### Optional Accessories

Accessories	Installation	VXLI-24	VXLI-16	VXLI-8	VXLI-16P	Description
Default (Supplied bracket) B W		✓	✓	✓	✓	For seamless wall mounting. This bracket does not allow angle adjustment.
WMB-L1 B W		✓	✓	✓	✓	Bracket for 2-axis adjustment of a single array.
VCB-L1 B		✓	✓	N/A	N/A	Bracket for vertical mounting of two arrays, for increased SPL and extra projection.
VCSB-L1 B W		✓	✓	N/A	N/A	Bracket for 2-axis adjustment of two vertically linked arrays. The VCB-L1 and WMB-L1 are used together.
HCB-L1 B		✓ with VXLI-24	✓ with VXLI-16	✓ with VXLI-8	✓	Bracket for side-by-side mounting of two arrays, for increased SPL and more focused horizontal dispersion that can minimize unwanted reflections from nearby surfaces.
PA-L1 B		✓	✓	✓	✓	Bracket for pole mounting. Suitable pole size Ø35 mm.
ST-L1 B W		✓	✓	✓	N/A	Transformer box for high-impedance connections. Ideal for multiple speaker layouts.



VXLI-16 with supplied bracket



VXLI-16s in vertical coupling with WMB-L1, VCB-L1, VCSB-L1



VXLI-16s in horizontal coupling with WMB-L1, HCB-L1

Standard



VXLI-24



VXLI-16



VXLI-8

PoE



VXLI-16P

VXL series	VXL1B-24/VXL1W-24	VXL1B-16/VXL1W-16	VXL1B-8/VXL1W-8	VXL1B-16P/VXL1W-16P
Speaker type	Full-range, Bass reflex	Full-range, Bass reflex	Full-range, Bass reflex	Full-range, Bass reflex Powered speaker (PoE)
Components	LF HF	1.5" x 24	1.5" x 16	1.5" x 8
Frequency range (-10dB)	Without port cover With port cover	77Hz - 20kHz 98Hz - 20kHz	81Hz - 20kHz 108Hz - 20kHz	70Hz - 20kHz 110Hz - 20kHz
Nominal coverage (Horizontal x Vertical)	Normal mode Wide mode	H170° x V15° (+7.5 / -7.5) H170° x V20° (+7.5 / -12.5)	H170° x V25° (+12.5 / -12.5) H170° x V30° (+12.5 / -17.5)	H170° x V40° (+20 / -20) -
Power rating	NOISE PGM PEAK	110W 220W 440W	80W 160W 320W	40W 80W 160W
Nominal impedance		8Ω	12Ω	16Ω
Transformer taps	100V 70V	With an optional transformer box (ST-L1): 60W, 30W, 15W With an optional transformer box (ST-L1): 60W, 30W, 15W, 7.5W		
Amplifier type		-	-	Class-D
Power rating (Amp)	Dynamic Continuous	-	-	15W (PoE + (IEEE 802.3 at)), 6W (PoE (IEEE 802.3 af)) 15W (PoE + (IEEE 802.3 at)), 6W (PoE (IEEE 802.3 af))
SPL	Sensitivity (1W, 1m) Peak (Calculated, 1m)	91dB SPL (Half-space) 117dB SPL	91dB SPL (Half-space) 116dB SPL	89dB SPL (Half-space) 111dB SPL 102dB SPL**
I/O connectors		Euroblock (2 pin)	Euroblock (2 pin)	Euroblock (2 pin) RJ45 (Dante)
Magnetically shielded		No		
Protection	Overload protection Speaker processing Amplifier protection Power supply protection	Full-range power limiting to protect network and transducers		
Cooling		-	-	Clip limiting, Integral power protection
Power requirements		-	-	Over current protection, Over temperature protection, Under voltage lock out, DC detection, Clock detection
Power consumption		-	-	Over load protection, Over voltage protection, Under voltage lock out Natural convection
Enclosure material	Cabinet Bottom board	Aluminum extrusion cabinet ABS (UL94 5VB)		
Grille material		Powder coated perforated aluminum Munsell N3 / RAL 9017 (approx.) Munsell N9 / RAL9010 (approx.)		
Finish	Black model White model			
Dust and water resistance (IP rating)		IP34*	IP34*	IP33*
Dimensions		W54mm (2.1") x H1212mm (47.7") x D104mm (4.1")	W54mm (2.1") x H846mm (33.3") x D104mm (4.1")	W54mm (2.1") x H480mm (18.9") x D104mm (4.1")
Net weight		5.5kg (12.1lbs)	3.9kg (8.6lbs)	2.1kg (4.6lbs)
Packaging		Single	Single	Single
Certificate		CE, RoHS	CE, RoHS	CE, RoHS

\* IP35 with port cover

\*\* Measured at 2 m; value converted to 1 m is shown (frequency range: 100Hz - 10kHz) ; IEC noise

In-ceiling Speakers

# VC SERIES

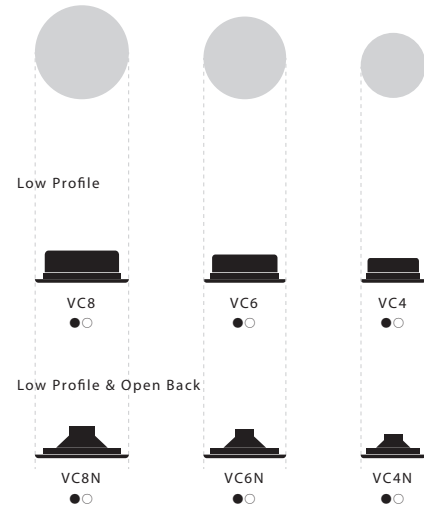

Recommended for  
**Speech / Background Music System**

## Premium Sounding Compact Ceiling Speakers at a Non-Premium Price.

VC series ceiling speakers for commercial installations deliver excellent sound quality at a price point traditionally reserved for economy speakers. A total of six models, three with back cans and three without, feature elegant low-profile designs that can be install easily even in limited ceiling or wall spaces. Large mounting clamps with non-slip treads ensure secure mounting.



**Fast**  
Double threaded screws used for the speaker clamp mechanism allow the clamps to be tightened twice as fast as conventional screws.

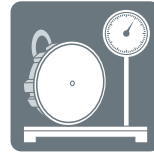

**Lightweight**  
Reduced weight increases installation flexibility while lessening the burden on installation personnel.



**Paintable**  
The supplied grilles can be painted any color to match interior decor.



**Hi-Z or Lo-Z**  
Both high-impedance and low-impedance connections are supported, and speaker wattage can be easily switched even after installation.



**Portable**  
A built-in "carrying band" not only makes the speaker easy to carry around, but also increases safety when working on a stepladder.  
\* VC8B, VC8W, VC6B, VC6W, VC4B, VC4W only

Versatile lineup for a variety of requirements

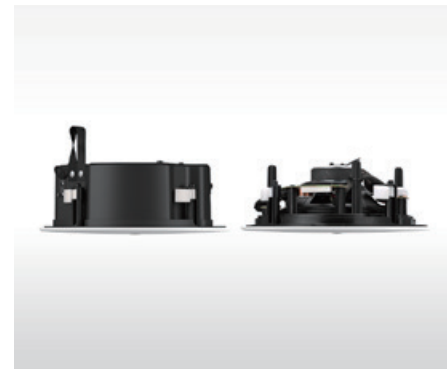

Extremely Low-profile



Pendant Speaker

# VXH SERIES

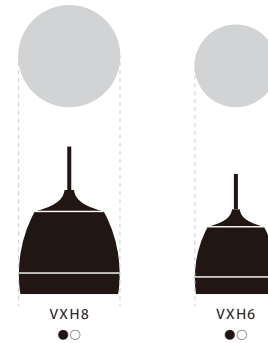

Recommended for  
**Background Music System**

## Stunning sound from any ceiling

VXH series pendant speakers are an ideal choice for open-structure or sloped ceilings, adding versatility for a variety of environments and sonic needs.

Two models are available: the wide-dispersion 6.5-inch VXH6 for use where the speakers are to be suspended at a relatively low position, and the high-power 8-inch VXH8 with narrower dispersion for higher suspension positions. You can select or mix and match models to achieve the best sound and coverage in any application.

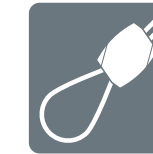

**Secure Installation**  
A suspension hardware and wire kit from Grippler, the world standard in suspension products, ensure, safe height adjustment during installation.

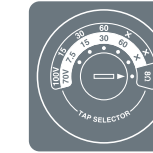

**Hi-Z or Lo-Z**  
Both high-impedance and low-impedance connections are supported, and speaker wattage can be easily switched even after installation.

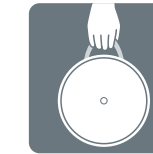

**Portable**  
A built-in "carrying band" not only makes the speaker easy to carry around, but also increases safety when working on a stepladder.



**Dust and Water Protection**  
VXH Series speakers are IP45 rated for use in a wide range of environments, including outdoors.  
\* Not for use in humid places.



**Paintable**  
The supplied grilles can be painted any color to match interior decor.

Models for a wide range of applications



World-class Installation Ease and Safety



### VC8

B W

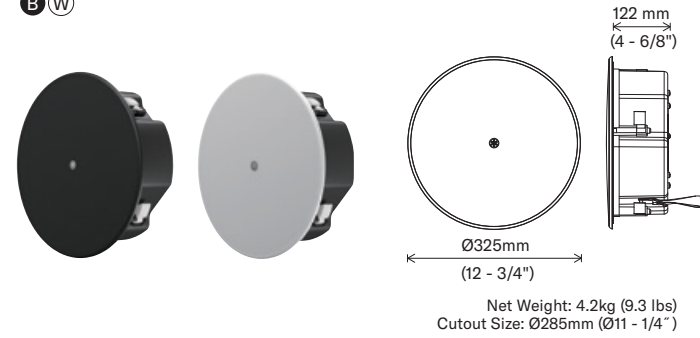

### VC6

B W

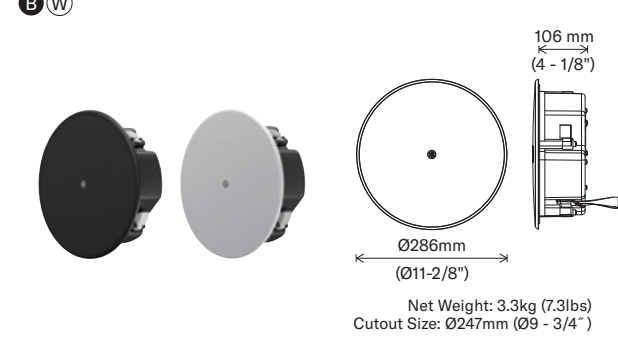

### VC4

B W

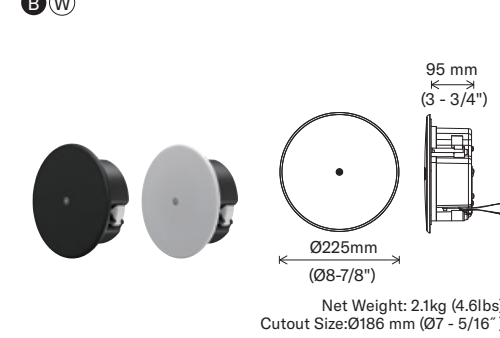

### VC8N

B W

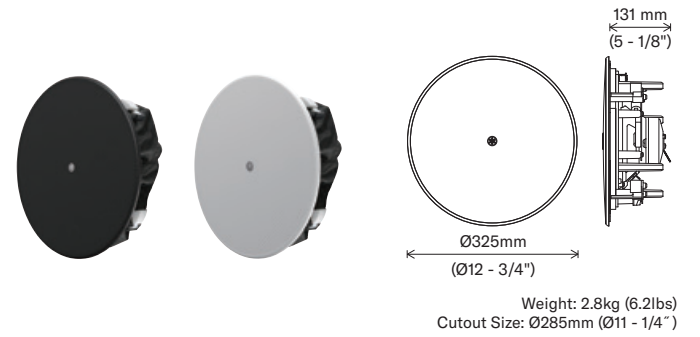

### VC6N

B W

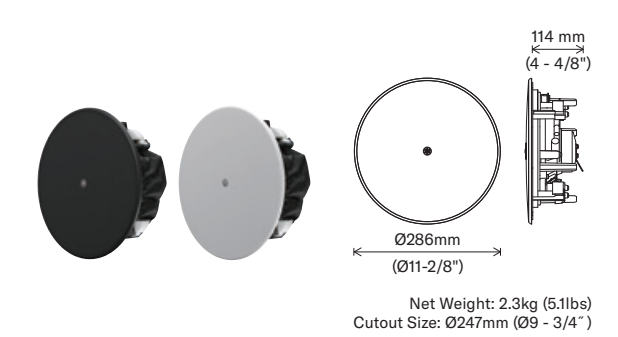

### VC4N

B W

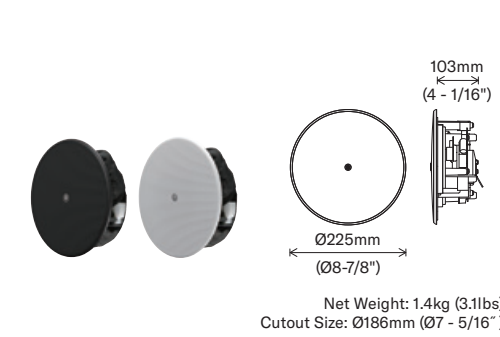

### Optional Accessories

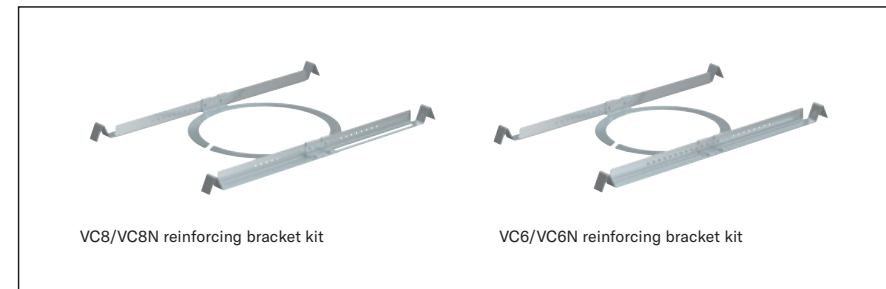

Low Profile

Low Profile & Open Back



VC/VCN series	VC8B / VC8W	VC6B / VC6W	VC4B / VC4W	VC8NB / VC8NW	VC6NB / VC6NW	VC4NB / VC4NW
Speaker type	2way Coaxial type, Acoustic Suspension					
Frequency range (-10dB)	96Hz - 20kHz (Half-space : 2π)	104Hz - 20kHz (Half-space : 2π)	121Hz - 20kHz (Half-space : 2π)	52Hz - 20kHz (Half-space : 2π)	63Hz - 20kHz (Half-space : 2π)	85Hz - 20kHz (Half-space : 2π)
Nominal coverage (Conical)	110° conical (Half-space : 2π)	120° conical (Half-space : 2π)	160° conical (Half-space : 2π)	110° conical (Half-space : 2π)	120° conical (Half-space : 2π)	160° conical (Half-space : 2π)
Components	LF 8" Cone HF 1" Soft dome	6.5" Cone 0.8" Soft dome	4" Cone 0.8" Film dome	8" Cone 1" Soft dome	6.5" Cone 0.8" Soft dome	4" Cone 0.8" Film dome
Power rating	NOISE PGM PEAK	25W 50W 100W	15W 30W 60W	25W 50W 100 W	15W 30W 60W	15W 30W 60W
Nominal impedance	16Ω					
Transformer taps	100V 70V	12W, 6W, 3W 12W, 6W, 3W, 1.5W	6W, 3W, 1.5W 6W, 3W, 1.5W, 0.8W	12W, 6W, 3W 12W, 6W, 3W, 1.5W	6W, 3W, 1.5W 6W, 3W, 1.5W, 0.8W	6W, 3W, 1.5W 6W, 3W, 1.5W, 0.8W
SPL	Sensitivity (1W, 1m) Peak (Calculated, 1m)	91dB SPL (Half-space : 2π) 111dB SPL (Calculated, 1m)	89dB SPL (Half-space : 2π) 109dB SPL (Calculated, 1m)	88dB SPL (Half-space : 2π) 106dB SPL (Calculated, 1m)	91dB SPL (Half-space : 2π) 111dB SPL (Calculated, 1 m)	89dB SPL (Half-space : 2π) 109dB SPL (Calculated, 1 m) 106dB SPL (Calculated, 1 m)
I/O connectors	Euroblock (4 pin) x1 (input: +/-, loop - thru: +/-), Wire size : Min. AWG24 (0.2 sq), Max. AWG12 (3.5 sq)			Push terminal (WAGO 294 /2 pin) x 1, Wire size : Solid conductor Min. AWG18 (0.75 sq) / Max. AWG12 (3.5 sq), Standard conductor Min. AWG18 (0.75 sq) / Max. AWG14 (2 sq)		
Protection circuit	Load protection	Full-range power limiting to protect network and transducers			Full-range power limiting to protect network and transducers	
Finish	Black model White model	Munsell N3 (approx.) Munsell N9.3 (approx.)				
Dimensions	325mm (12 - 3/4") x D122mm (4 - 6/8")	286mm (11 - 2/8") x 106mm (4 - 1/8")	225mm (8 - 7/8") x 95mm (3 - 3/4")	325mm (12 - 3/4") x 131mm (5 - 1/8")	286mm (11 - 2/8") x 114mm (4 - 4/8")	225mm (8 - 7/8") x 103mm (4 - 1/16")
Net weight	4.2kg (9.3 lbs)	3.3kg (7.3 lbs)	2.1kg (4.6 lbs)	2.8kg (6.2 lbs)	2.3kg (5.1 lbs)	1.4kg (3.1 lbs)
Cutout size	Ø285mm (Ø11-1/4")	Ø247mm (Ø9-3/4")	Ø186mm (Ø7-5/16")	Ø285mm (Ø11 - 1/4")	Ø247mm (Ø9 - 3/4")	Ø186mm (Ø7 - 5/16")
Required ceiling board thickness	2 mm - 37 mm					
Accessories	C-Ring, Tile Rails x 2, Grille, Safety wire, Cutout template, Owner's Manual		Grille, Safety wire, Cutout template, Owner's Manual	C-Ring, Tile Rails x 2, Grille, Safety wire, Cutout template, Owner's Manual		Grille, Safety wire, Cutout template, Owner's Manual
Packaging	Single package					
Certificate	UL1480A, UL2043, NFPA70, CE, RoHS			CE, RoHS		
Options	-	-	AB-C2: C-ring + Tile Rail kit	-	-	AB-C2: C-ring + Tile Rail kit

## VXH8

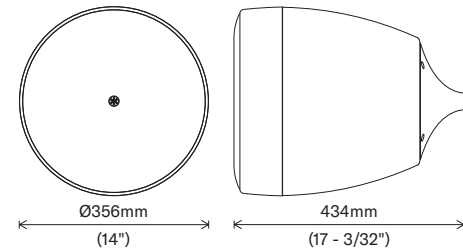

Weight: 7.2kg

## VXH6

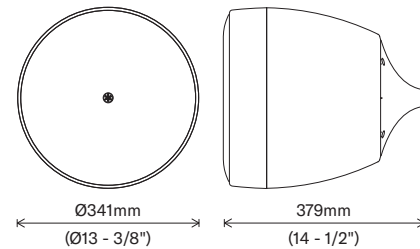

Weight: 5.7kg



VXH8



VXH6

VXH series	VXH8B/VXH8W	VXH6B/VXH6W	
Speaker type	Coaxial 2 way, Bass reflex type		
Frequency range (-10dB)	57Hz - 20kHz (Full-space : 4π)	55Hz - 20kHz (Full-space : 4π)	
Nominal coverage (Conical)	75° conical (Full-space : 4π)	120° conical (Full-space : 4π)	
Crossover Frequencies	3kHz		
Components	8" Cone	6.5" Cone	
	1" Soft Dome		
Power rating	NOISE	90W	75W
	PGM	180W	150W
	PEAK	360W	300W
Nominal impedance	8 Ω		
Transformer tap	100V	60W, 30W, 15W	60W, 30W, 15W
	70V	60W, 30W, 15W, 7.5W	60W, 30W, 15W, 7.5W
SPL	Sensitivity (1W; 1m on axis)	94dB (Full-space : 4π)	93dB (Full-space : 4π)
	Peak (Calculated, 1m)	120dB (Calculated, 1 m)	118dB (Calculated, 1 m)
I/O connectors	Euroblock (4 pin) × 1 (input: +/-, loop-thru: +/-): Min. wire size AWG 24 (0.2 sq), Max. wire size AWG 12 (3.5 sq)		
Protection circuit	Load protection	Full-range power limiting to protect network and transducers	
Finish	Black model	Munsell N3 (approx.)	
	White model	Munsell N9.3 (approx.)	
Dimensions	Diameter	Ø356mm (14")	Ø341mm (13 - 3/8")
	D	434mm (17 - 3/32")	379mm (14 - 1/2")
Net weight		7.2kg (15.9 lbs)	5.7kg (12.6 lbs)
Accessories	Grippler Kit x1, Euro Block (4 pin) x1, Cushion Seal x1, Back Cover Set x1, Owner's Manual x1, GRIPPLE Kit Installation Guide x1		
Dust and water resistant	IP45 (when waterproofing the cover hole)		
Packaging	Single package		
Certificate	UL1480A, NFPA70, CE, RoHS		

## System Example

### Large Shopping Mall

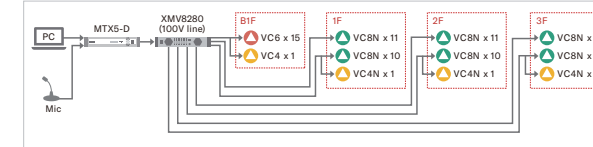

### Amusement Facility (Aquarium)

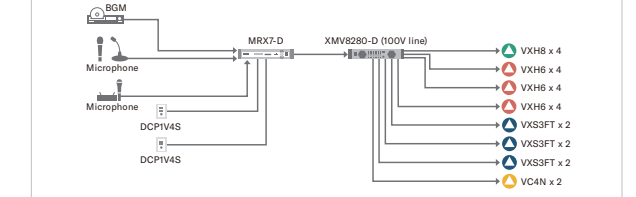
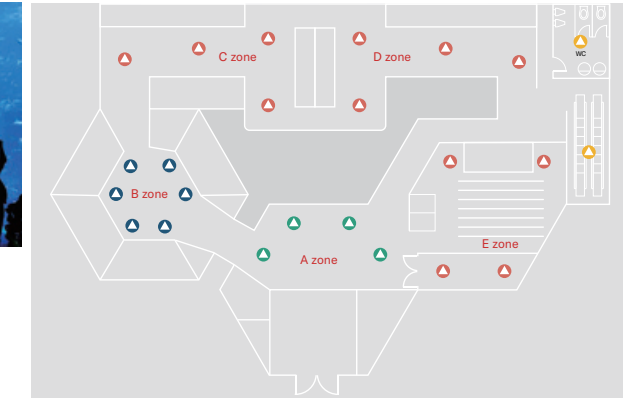

### Meeting space

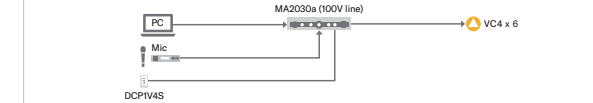
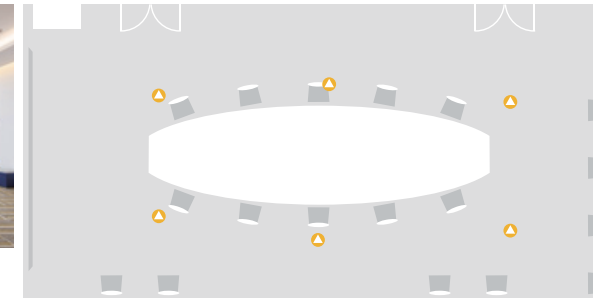

### Restaurant

