

***msi***<sup>®</sup>

**S1205 (1U12)**

**MS-S321**

Server System  
User Guide

# Contents

Regulatory Notices.....	4
Safety Information.....	6
System Specifications.....	7
System Overview.....	9
Block Diagram.....	12
System Storage Topology.....	13
System LED Indicators.....	14
Motherboard Overview.....	15
Motherboard Connectors.....	16
Storage Connectors.....	16
Expansion Slots.....	19
Power Connectors.....	20
Cooling Connectors.....	21
USB Connectors.....	22
Motherboard Jumpers.....	30
Motherboard LEDs.....	31
Getting Started.....	32
Necessary Tools.....	32
Safety Precautions.....	32
System Setup.....	33
Drive Bay.....	33
Installing 2.5" HDD/ SSD.....	33
System Cover.....	34
Removing System Cover.....	34

## Revision

V1.3, 2024/04

CPU & Heatsink.....	35
Assembly Overview.....	36
Installing CPU & Heatsink.....	37
Memory .....	39
Recommended Memory Population.....	40
Installing Memory Modules.....	42
M.2 M Key.....	43
Installing M.2 M Key .....	43
PCIe Add-in Card.....	44
Installing PCIe Add-in Card.....	44
Installing Riser Card Assembly.....	45
System Fan .....	46
Installing 1U Fan.....	46
Power Supply Unit (PSU) .....	47
Installing PSU .....	47
Cable Routing .....	48
Slide Rail .....	50
Disassembling Slide Rail.....	50
Installing Inner Rail to System.....	51
Retracting Outer Rail Bracket.....	52
Attaching Outer Rail Bracket to Rack Frame .....	52
Installing System into Rack.....	53
Detaching Outer Rail Bracket from Rack Frame.....	54
Detaching Inner Rail from System.....	54

# Regulatory Notices

## WEEE Statement

Under the European Union (“EU”) Directive on Waste Electrical and Electronic Equipment, Directive 2012/19/EU, products of “electrical and electronic equipment” cannot be discarded as municipal waste anymore and manufacturers of covered electronic equipment will be obligated to take back such products at the end of their useful life.



## Chemical Substances Information

In compliance with chemical substances regulations, such as the EU REACH Regulation (Regulation EC No. 1907/2006 of the European Parliament and the Council), MSI provides the information of chemical substances in products at:

<https://csr.msi.com/global/index>

## CE Conformity

Hereby, Micro-Star International CO., LTD declares that this device is in compliance with the essential safety requirements and other relevant provisions set out in the European Directive.



## FCC-A Radio Frequency Interference Statement

This equipment has been tested and found to comply with the limits for a Class A digital device, pursuant to Part 15 of the FCC Rules. These limits are designed to provide reasonable protection against harmful interference when the equipment is operated in a commercial environment. This equipment generates, uses and can radiate radio frequency energy and, if not installed and used in accordance with the instruction manual, may cause harmful interference to radio communications. Operation of this equipment in a residential area is likely to cause harmful interference, in which case the user will be required to correct the interference at his own expense.



### Notice 1

The changes or modifications not expressly approved by the party responsible for compliance could void the user’s authority to operate the equipment.

### Notice 2

Shielded interface cables and AC power cord, if any, must be used in order to comply with the emission limits.

This device complies with Part 15 of the FCC Rules. Operation is subject to the following two conditions:

- This device may not cause harmful interference, and
- This device must accept any interference received, including interference that may cause undesired operation.

## Battery Information

Please take special precautions if this product comes with a battery.

- Danger of explosion if battery is incorrectly replaced. Replace only with the same or equivalent type recommended by the manufacturer.
- Avoid disposal of a battery into fire or a hot oven, or mechanically crushing or cutting of a battery, which can result in an explosion.
- Avoid leaving a battery in an extremely high temperature or extremely low air pressure environment that can result in an explosion or the leakage of flammable liquid or gas.
- Do not ingest battery. If the coin/button cell battery is swallowed, it can cause severe internal burns and can lead to death. Keep new and used batteries away from children.

### European Union:



Batteries, battery packs, and accumulators should not be disposed of as unsorted household waste. Please use the public collection system to return, recycle, or treat them in compliance with the local regulations.

### BSMI:



廢電池請回收

For better environmental protection, waste batteries should be collected separately for recycling or special disposal.

### California, USA:



The button cell battery may contain perchlorate material and requires special handling when recycled or disposed of in California.

For further information please visit:

<http://www.dtsc.ca.gov/hazardouswaste/perchlorate/>

## Copyright and Trademarks Notice

**msi**

**MSI**

**微星**

**微星科技**  
MICRO-STAR INTERNATIONAL



Copyright © Micro-Star Int'l Co., Ltd. All rights reserved. The MSI logo used is a registered trademark of Micro-Star Int'l Co., Ltd. All other marks and names mentioned may be trademarks of their respective owners. No warranty as to accuracy or completeness is expressed or implied. MSI reserves the right to make changes to this document without prior notice.

## Technical Support

If a problem arises with your product and no solution can be obtained from the user's manual, please contact your place of purchase or local distributor. Alternatively, please visit <https://eps.msi.com/support> for further guidance.

# Safety Information

- Always read the safety instructions carefully.
- Keep this User's Manual for future reference.
- Keep this equipment away from humidity.
- Lay this equipment on a reliable flat surface before setting it up.
- The openings on the enclosure are for air convection hence protects the equipment from overheating. **Do not cover the openings.**
- Make sure the voltage of the power source and adjust properly before connecting the equipment to the power inlet.
- Place the power cord such a way that people can not step on it. Do not place anything over the power cord.
- Always unplug the power cord before inserting any add-on card or module.
- All cautions and warnings on the equipment should be noted.
- Never pour any liquid into the opening that could damage or cause electrical shock.
- If any of the following situations arises, get the equipment checked by service personnel:
  - The power cord or plug is damaged.
  - Liquid has penetrated into the equipment.
  - The equipment has been exposed to moisture.
  - The equipment does not work well or you can not get it work according to User's Manual.
  - The equipment has dropped and damaged.
  - The equipment has obvious sign of breakage.
- **Do not leave this equipment in an environment unconditioned, storage temperature above 60°C (140°F), it may damage the equipment.**

# System Specifications

SKUs	S1205-01	S1205-01-10G
Form factor	1U	
Dimensions	438mm(17.2") W x 43.2mm(1.7")H x 770mm(30.3")D	
Processor	Dual 4th/5th Gen Intel® Xeon® Scalable processors, TDP up to 350W	
Socket	2 x Intel LGA 4677 (Socket E)	
Chipset	Intel® C741 Chipset	
Networking	<ul style="list-style-type: none"> <li>• <b>No onboard LAN</b></li> <li>• <b>2 x GbE RJ45 ports</b> <ul style="list-style-type: none"> <li>- Through M.2 LAN module NAD-101 (optional)</li> </ul> </li> </ul>	<ul style="list-style-type: none"> <li>• <b>2 x 10GSFP+ LAN ports</b> <ul style="list-style-type: none"> <li>- Intel® LAN controller X710-AT2</li> <li>- Through OCP NIC 3.0 LAN adapter OCP-321</li> </ul> </li> <li>• <b>2 x GbE RJ45 ports</b> <ul style="list-style-type: none"> <li>- Through M.2 LAN module NAD-101 (optional)</li> </ul> </li> </ul>
RAID	Intel® SATA RAID 0/1/10/5	
Memory	<ul style="list-style-type: none"> <li>• 32 x DDR5 DIMM slots, 16 channels (2DPC), RDIMM/ 3DS-RDIMM</li> <li>- Max Frequency:           <ul style="list-style-type: none"> <li>» 5th Gen Intel® Xeon®: 5600 MT/s (1DPC), 4400 MT/s (2DPC)</li> <li>» 4th Gen Intel® Xeon®: 4800 MT/s (1DPC), 4400 MT/s (2DPC)</li> </ul> </li> <li>- Max Capacity per DIMM:           <ul style="list-style-type: none"> <li>» RDIMM: 96GB</li> <li>» 3DS-RDIMM: 256GB</li> </ul> </li> </ul>	
Drive Bays	<ul style="list-style-type: none"> <li>• 12 x 2.5" hot-swap drive bays</li> <li>- Supports U.2 PCIe 4.0 NVMe signals</li> </ul>	
Internal Storage	2 x M.2 M-key (PCIe 3.0 x2, 2280/ 22110) (from PCH)	
Expansion Slots	<ul style="list-style-type: none"> <li>• 3 x PCIe slots           <ul style="list-style-type: none"> <li>- RISER1:               <ul style="list-style-type: none"> <li>» 1 x PCIe 4.0 x16 slot (PCIe 4.0 x16 signal, from CPU0, supporting LP PCIe card)</li> </ul> </li> <li>- RISER2:               <ul style="list-style-type: none"> <li>» 1 x PCIe 4.0 x16 slot (PCIe 4.0 x16 signal, from CPU1, supporting LP PCIe card)</li> </ul> </li> <li>- RISER4:               <ul style="list-style-type: none"> <li>» 1 x PCIe 3.0 x16 slot (PCIe 3.0 x16 signal, from CPU1, supporting LP PCIe card)</li> </ul> </li> </ul> </li> <li>• 1 x OCP 3.0 Mezzanine card slot (PCIe 4.0 x16 signal, from CPU0)           <ul style="list-style-type: none"> <li>- Supports NCSI</li> </ul> </li> </ul>	
Front Panel	<ul style="list-style-type: none"> <li>• 2 x USB 2.0 Type-A ports</li> <li>• 1 x System power LED button</li> <li>• 1 x UID LED button</li> <li>• 1 x Reset button</li> <li>• 4 x Status LEDs (M.2/ Alarm/ 2 x LANs)</li> </ul>	

Continued on next column

SKUs	S1205-01	S1205-01-10G
Rear Panel	<ul style="list-style-type: none"> <li>• 1 x GbE RJ45 Port (mgmt.)</li> <li>• 2 x USB 2.0 Type-A ports</li> <li>• 1 x COM RJ45 port</li> <li>• 1 x VGA port</li> <li>• 1 x UID LED button*</li> </ul> <p>*The UID LED button can also function as a <b>BMC reset button</b> by configuring <a href="#">jumper: J1_1</a>.</p>	
TPM	1 x TPM header (with SPI interface)	
Security	TPM 2.0	
Server Management	<ul style="list-style-type: none"> <li>• 1 x GbE RJ45 Port (mgmt.) (Realtek® RTL8211FD-CG)</li> <li>• 1 x MicroSD card slot (for BMC log)</li> <li>• ASPEED AST2600 with AMI MegaRAC based firmware <ul style="list-style-type: none"> <li>- Supports IPMI 2.0 and DMTF Redfish® API</li> </ul> </li> <li>• Dual BIOS and BMC supported</li> </ul>	
Cooling	<ul style="list-style-type: none"> <li>• 2 x Passive air cooling modules (for max 205W CPU)</li> <li>• 8 x 4056 easy-swap system fans</li> </ul>	
Environment	<ul style="list-style-type: none"> <li>• Operating Temperature: 0°C ~ 35°C</li> <li>• Non-operating Temperature: -20°C ~ 70°C</li> <li>• Non-operating Relative Humidity: 5% ~ 85% (non-condensing)</li> </ul>	
Power Supply	(1+1) 1300W CRPS, 80 PLUS® Platinum	
Certification	CE, FCC (Class A)	

# System Overview

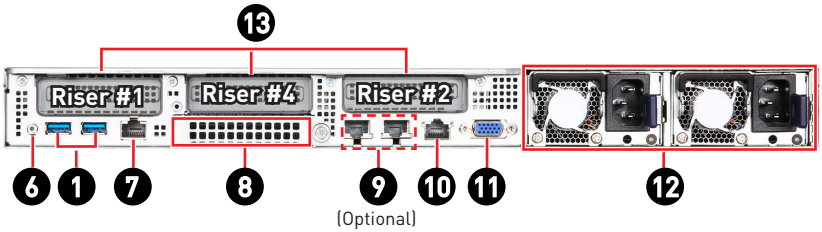
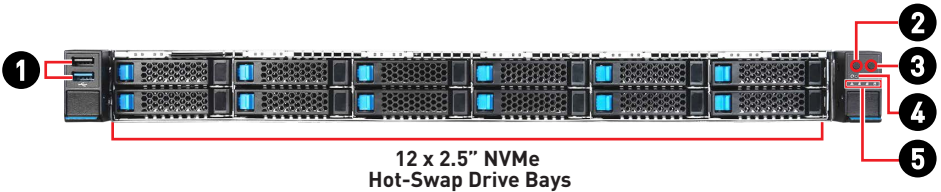

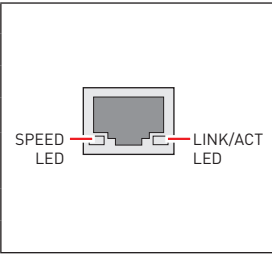
<p><b>1</b></p>	<p><b>USB 2.0 Type-A Port</b></p> <p>This connector is provided for USB peripheral devices. (Speed up to 480 Mbps)</p> <p><b>! Important</b></p> <p><i>High-speed devices are recommended for USB 3.2 ports whereas low-speed devices, such as mouse or keyboard, are suggested to be plugged into the USB 2.0 ports.</i></p>																	
<p><b>2</b></p>	<p><b>System Power Button/ LED</b></p>																	
<p><b>3</b></p>	<p><b>UID Button/ LED</b></p>																	
<p><b>4</b></p>	<p><b>System Reset Button</b></p>																	
<p><b>5</b></p>	<p><b>System Alarm LED</b></p> <p><b>NIC Link LEDs</b></p> <p><b>M.2 Activity LED</b></p>																	
<p><b>6</b></p>	<p><b>UID LED Button (or BMC Reset Button, configured using jumper: J1_1)</b></p>																	
<p><b>7</b></p>	<p><b>COM RJ45 Port</b></p>																	
<p><b>8</b></p>	<p><b>OCP Mezzanine card slot</b></p>																	
<p><b>9</b></p>	<p><b>GbE RJ45 Port (Optional)</b></p> <p>The standard RJ45 LAN jack is provided for connection to the Local Area Network (LAN). You can connect a network cable to it.</p> <table border="1" data-bbox="200 1061 931 1316"> <thead> <tr> <th>LED</th> <th>Status</th> <th>Description</th> </tr> </thead> <tbody> <tr> <td rowspan="3">Link/ Activity LED</td> <td>Off</td> <td>No link</td> </tr> <tr> <td>Green</td> <td>Linked</td> </tr> <tr> <td>Blinking</td> <td>Data activity</td> </tr> <tr> <td rowspan="3">Speed LED</td> <td>Off</td> <td>10 Mbps/ No LAN linked</td> </tr> <tr> <td>Orange</td> <td>100 Mbps</td> </tr> <tr> <td>Green</td> <td>1 Gbps</td> </tr> </tbody> </table> 	LED	Status	Description	Link/ Activity LED	Off	No link	Green	Linked	Blinking	Data activity	Speed LED	Off	10 Mbps/ No LAN linked	Orange	100 Mbps	Green	1 Gbps
LED	Status	Description																
Link/ Activity LED	Off	No link																
	Green	Linked																
	Blinking	Data activity																
Speed LED	Off	10 Mbps/ No LAN linked																
	Orange	100 Mbps																
	Green	1 Gbps																

Continued on next column

### 10 GbE RJ45 Port (mgmt.)

The standard RJ45 LAN jack is provided for connection to the Local Area Network (LAN). You can connect a network cable to it.

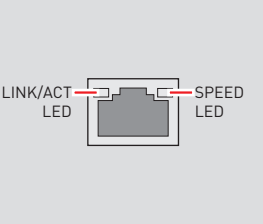
	LED	Status	Description
	Link/ Activity LED	<input type="radio"/> Off	No link
		<input checked="" type="radio"/> Green	Linked
		<input type="radio"/> Blinking	Data activity
	Speed LED	<input type="radio"/> Off	10 Mbps
		<input type="radio"/> Orange	100 Mbps
		<input checked="" type="radio"/> Green	1 Gbps

### 11 VGA Port

### 12 Power Supply Unit

### 13 PCIe Add-in Card Area

# Block Diagram

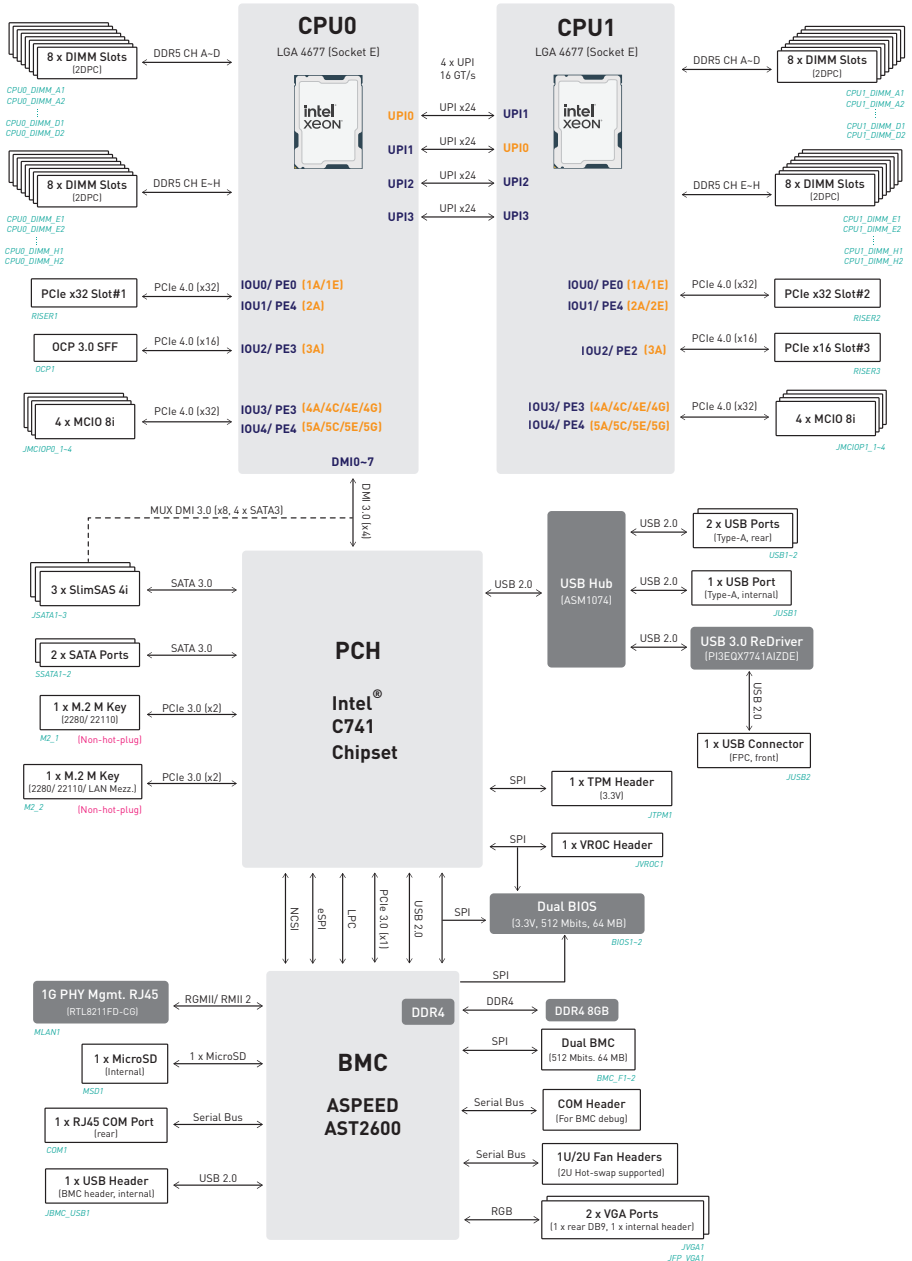

# System Storage Topology



12 x NVMe Signal					
#11	#9	#7	#5	#3	#1
<b>NVMe</b>	<b>NVMe</b>	<b>NVMe</b>	<b>NVMe</b>	<b>NVMe</b>	<b>NVMe</b>
CPU1 PE3	CPU1 PE3	CPU0 PE4	CPU0 PE4	CPU0 PE3	CPU0 PE3
Port 4E	Port 4A	Port 5E	Port 5A	Port 4E	Port 4A
Lanes 8:11	Lanes 0:3	Lanes 8:11	Lanes 0:3	Lanes 8:11	Lanes 0:3
#12	#10	#8	#6	#4	#2
<b>NVMe</b>	<b>NVMe</b>	<b>NVMe</b>	<b>NVMe</b>	<b>NVMe</b>	<b>NVMe</b>
CPU1 PE3	CPU1 PE3	CPU1 PE3	CPU0 PE4	CPU0 PE3	CPU0 PE3
Port 4G	Port 4C	Port 5G	Port 5C	Port 4G	Port 4C
Lanes 12:15	Lanes 4:7	Lanes 12:15	Lanes 4:7	Lanes 12:15	Lanes 4:7

# System LED Indicators

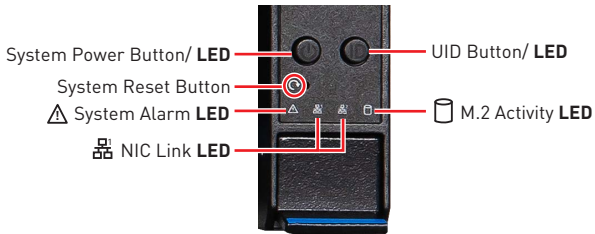

LED	LED State	Description
System Power LED	● Blue	System power is on System power is on ACPI S0 state
	◐ Blinking	System is sleeping
	○ Off	System power is off System power is on ACPI S4, S5 state
UID LED	● Blue	Identify active via command or button
	○ Off	No identification
⚠ System Alarm LED	● Green	BMC initialization
	● Red	System has failed
	○ Off	System is running/ normal operation
📶 NIC Link LED	◐ Blinking	NIC activity is occurring
	○ Off	NIC link is not established
📀 M.2 Activity LED	● Amber	M.2 present, no activity
	◐ Blinking	M.2 accessing
	○ Off	No M.2 activity

# Motherboard Overview

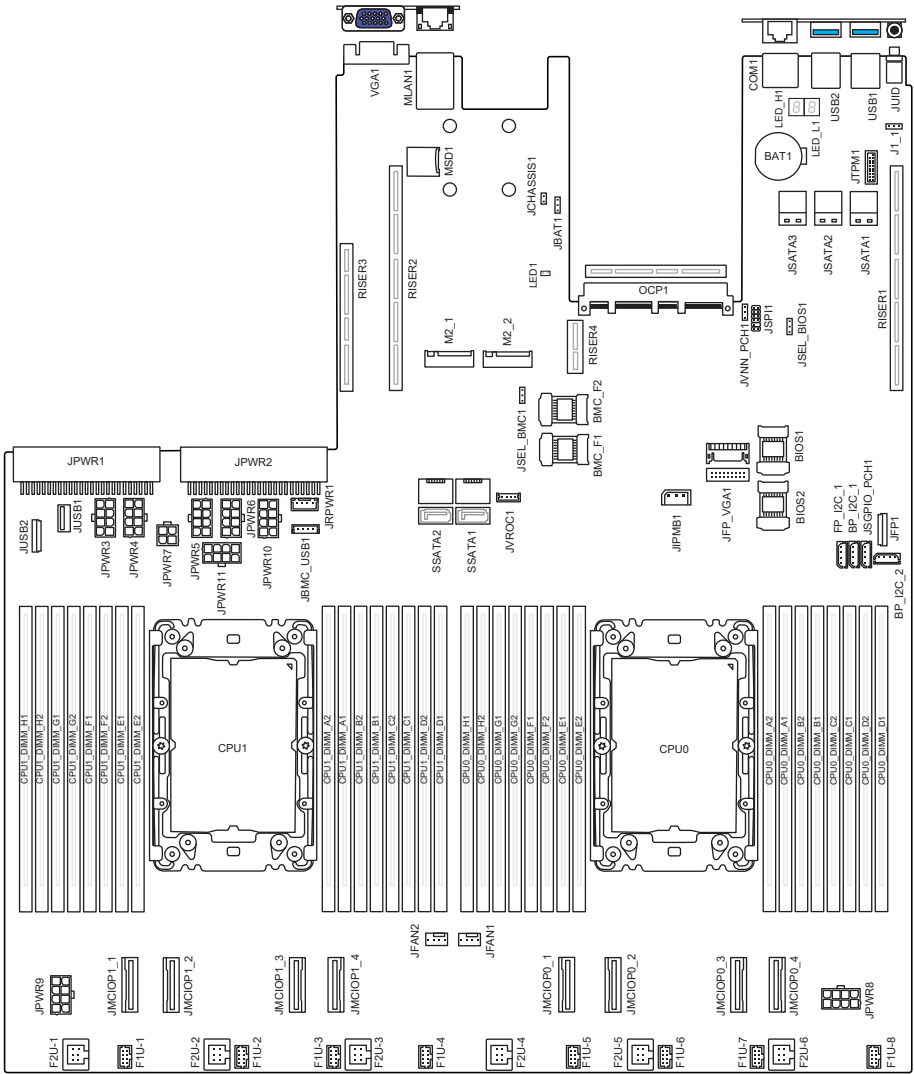

# Motherboard Connectors

## Storage Connectors

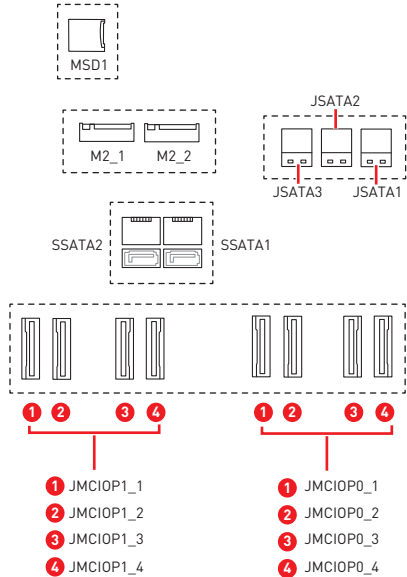
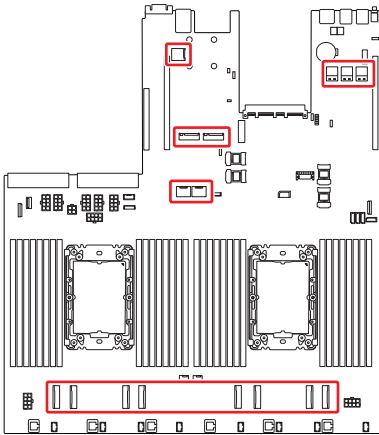

Name	Description
SSATA1~2	SATA 3.0, 6Gb/s
JSATA1~3	SATA 3.0, 6Gb/s
M2_1~2	PCIe 3.0 x2, 8GT/s
JMCIOP0_1~4	PCIe 4.0 x8, 16GT/s
JMCIOP1_1~4	

### M2\_1, M2\_2: M.2 Slot (M Key, PCIe 3.0 x2, 22110/ 2280)

The M.2 slot supports solid-state drive (SSD). For installation procedure, please refer to **"System Setup > M.2 M Key"**.

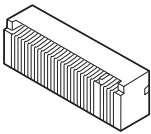

### MSD1: Micro SD Card Slot

This slot is for inserting the micro SD card.

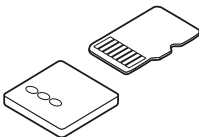

## JSATA1~3: Slimline SAS 4i Connectors

These connectors provide storage support for SATA devices.

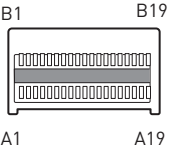
<p>JSATA1~3</p> 	A1	GND	B1	GND
	A2	JSATA_P0_RX+	B2	JSATA_P0_TX+
	A3	JSATA_P0_RX-	B3	JSATA_P0_TX-
	A4	GND	B4	GND
	A5	JSATA_P1_RX+	B5	JSATA_P1_TX+
	A6	JSATA_P1_RX-	B6	JSATA_P1_TX-
	A7	GND	B7	GND
	A8	BP TYPE	B8	SGPIO_SATA_CLOCK_R
	A9	SGPIO_SATA_DATAOUT_R	B9	SGPIO_SATA_LOAD_R
	A10	GND	B10	GND
	A11	NC	B11	P3V3
	A12	NC	B12	NC
	A13	GND	B13	GND
	A14	JSATA_P2_RX+	B14	JSATA_P2_TX+
	A15	JSATA_P2_RX-	B15	JSATA_P2_TX-
	A16	GND	B16	GND
	A17	JSATA_P3_RX+	B17	JSATA_P3_TX+
	A18	JSATA_P3_RX-	B18	JSATA_P3_TX-
	A19	GND	B19	GND

## SSATA1~2: SATA 3.0 DOM Ports (6Gb/s)

These connectors are SATA 6Gb/s interface ports. Each connector can connect to one SATA device.

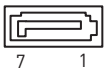
<p>SSATA1~2</p> 	1	GND	5	TX_DN
	2	RX_DP	6	TX_DP
	3	RX_DN	7	GND
	4	GND		



### Important

- Please do not fold the SATA cable at a 90-degree angle. Data loss may result during transmission otherwise.
- SATA cables have identical plugs on either sides of the cable. However, it is recommended that the flat connector be connected to the motherboard for space saving purposes.

## JMCIOP0\_1~4, JMCIOP1\_1~4: MCI0 8i Connectors

These are vertical 74-pin Mini Cool Edge IO (MCI0) connectors, which support PCIe 4.0 x8 16GT/s interface.

	A1	GND	B1	GND
	A2	SSD_RX+	B2	SSD_TX+
	A3	SSD_RX-	B3	SSD_TX-
	A4	GND	B4	GND
	A5	SSD_RX+	B5	SSD_TX+
	A6	SSD_RX-	B6	SSD_TX-
	A7	GND	B7	GND
	A8	NC	B8	SMB_PEHPCPU_LV3_SCL
	A9	FM_SMB_CPU_ALERT_N	B9	SMB_PEHPCPU_LV3_SDA
	A10	GND	B10	GND
	A11	CLK_100M_SSD_DP	B11	RST_PCIE_CPU_PERST_N
	A12	CLK_100M_SSD_DN	B12	FM_PCIE_SSD_PRSNNT_N
	A13	GND	B13	GND
	A14	SSD_RX+	B14	SSD_TX+
	A15	SSD_RX-	B15	SSD_TX-
	A16	GND	B16	GND
	A17	SSD_RX+	B17	SSD_TX+
	A18	SSD_RX-	B18	SSD_TX-
	A19	GND	B19	GND
	A20	SSD_RX+	B20	SSD_TX+
	A21	SSD_RX-	B21	SSD_TX-
	A22	GND	B22	GND
	A23	SSD_RX+	B23	SSD_TX+
	A24	SSD_RX-	B24	SSD_TX-
	A25	GND	B25	GND
	A26	NC	B26	SMB_PEHPCPU_LV3_SCL
	A27	FM_SMB_CPU_ALERT_N	B27	SMB_PEHPCPU_LV3_SDA
	A28	GND	B28	GND
	A29	CLK_100M_SSD_DP	B29	RST_PCIE_CPU_PESSET_N
	A30	CLK_100M_SSD_DN	B30	FM_PCIE_SSD_PRSNNT_N
	A31	GND	B31	GND
	A32	SSD_RX+	B32	SSD_TX+
	A33	SSD_RX-	B33	SSD_TX-
	A34	GND	B34	GND
	A35	SSD_RX+	B35	SSD_TX+
	A36	SSD_RX-	B36	SSD_TX-
	A37	GND	B37	GND

JMCIOP0\_1~4  
JMCIOP1\_1~4

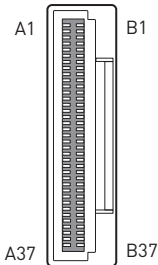

# Expansion Slots

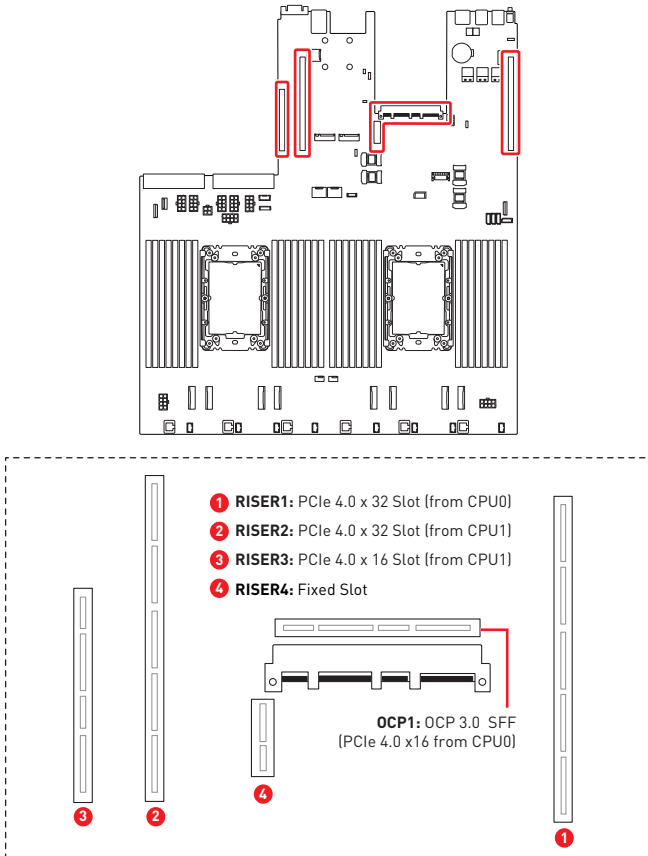

## RISER1~4: PCIe Expansion Slots

The PCI Express(Peripheral Component Interconnect Express) slots support PCIe interface expansion cards.

## OCP1: OCP (Open Compute Project) LAN Mezzanine Slot

The slots allows the deployment of a wide variety of additional networking options through OCP Mezzanine Ethernet cards.



### Important

When adding or removing expansion cards, make sure that you unplug the power supply first. Meanwhile, read the documentation for the expansion card to configure any necessary hardware or software settings for the expansion card, such as jumpers, switches or BIOS configuration.

# Power Connectors

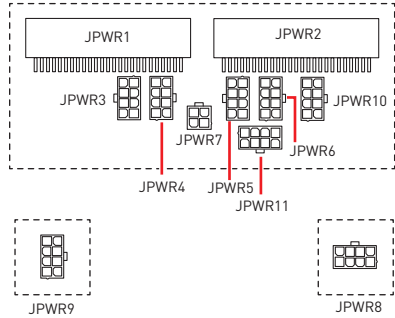
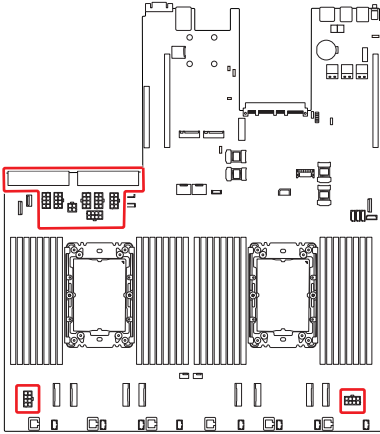

## JPWR1~2: CRPS Power Connectors

These CRPS (Common Redundant Power Supplies) connectors allow you to connect a power supply. To connect the power supply, ensure that the plug is inserted in the proper orientation and that the pins are aligned. Then firmly push down the power supply into the connector.

## JPWR3~6, JPWR10~11: 8-Pin GPU Power Connectors

These connectors provide power output to GPUs.

## JPWR8~9: 8-Pin HDD BP Power Connectors

These connectors provide power output to HDDs.

JPWR3	JPWR8		1	GND	2	GND
JPWR4	JPWR9		3	GND	4	GND
JPWR5	JPWR10		5	+12V	6	+12V
JPWR6	JPWR11		7	+12V	8	+12V

## JPWR7: 4-Pin Rear BP Power Connector

This connector provides power output to HDDs on rear side.

JPWR7	1		2	GND
	3		4	P12V

### Important

Make sure that all power connectors are securely connected to the power supply to ensure stable operation of the motherboard.

# Cooling Connectors

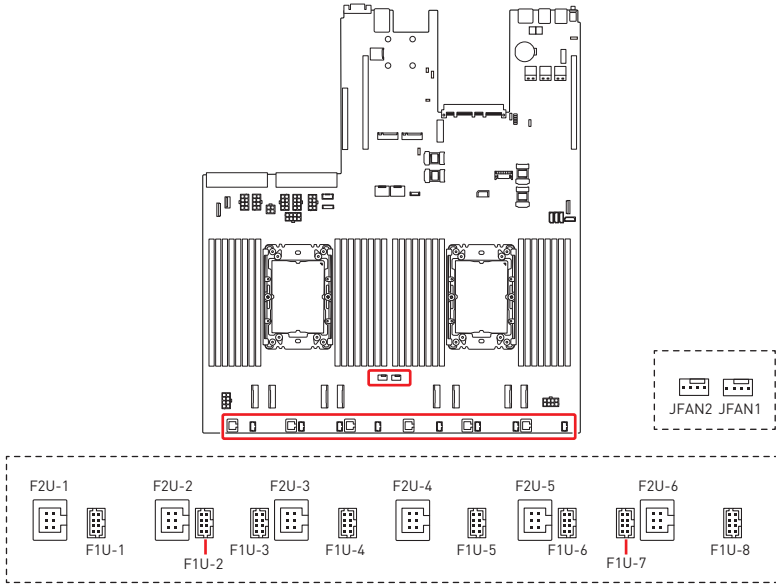

## F2U1~6: 2U System Fan Connectors

The fan power connectors support 2U system cooling fans.

	1	GND	2	P12V
	3	FAN_TACH	4	BMC_PWM
	5	FAN_PRSENT	6	FAN_FAULT

## F1U1~8: 1U System Fan Connectors

The fan power connectors support 1U system cooling fans.

	1	FAN_TACH	2	FAN_PWM
	3	P12V	4	P12V
	5	FAN_TACH	6	GND
	7	GND	8	FAN_PRSENT

## JFAN1~2: CPU Fan Connectors

The fan power connectors support CPU cooling fans.

	1	GND	3	FAN SENSE
	2	P12V	4	FAN_PWM

# USB Connectors

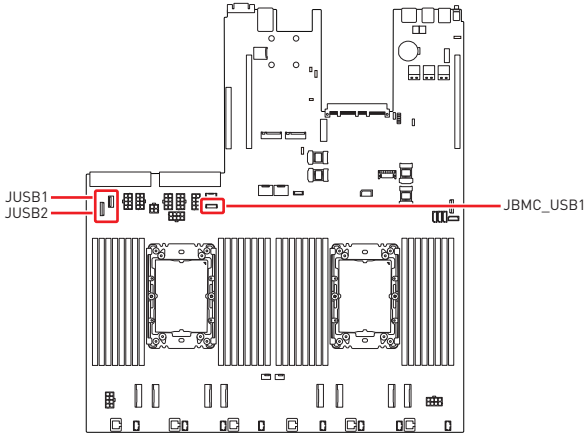

## JUSB1: USB 2.0 Type-A Port

The USB (Universal Serial Bus) port is for attaching USB devices such as keyboard, mouse, or other USB-compatible devices. It supports up to **480 Mbps** data transfer rate.

JUSB1



## JUSB2: USB 2.0 FPC Connector

This port supports USB 2.0 devices with data transfer rate up to **480 Mbps**.

	1	USB_VCC1	2	USB_VCC1
	3	USB_VCC1	4	USB_VCC1
	5	USB_VCC1	6	USB_VCC1
	7	GND	8	GND
	9	GND	10	GND
	11	GND	12	GND
	13	GND	14	GND
	15	USB3_P04_ESD_RXN	16	USB3_P04_ESD_RXP
	17	GND	18	USB3_P04_ESD_TXN
	19	USB3_P04_ESD_TXP	20	GND
	21	PCH_USB2_P02_ESD_DN	22	PCH_USB2_P02_ESD_DP
	23	GND	24	PCH_USB2_P03_ESD_DN
	25	PCH_USB2_P03_ESD_DP	26	GND

## JBMC\_USB1: BMC USB 2.0 Header

This connector is used to connect USB devices and link to BMC for applications.

JBMC_USB1	1		4	1	P5V_AUX	3	BMC_USB2B_HOST_DN
				2	BMC_USB2B_HOST_DP	4	GND

# Other Connectors and Components

## JFP1: Front Panel FPC Connector

The front panel connector is provided for electrical connection to the front panel switches and LEDs.

 <p>JFP1</p>	1	P3V3_AUX	2	P3V3_AUX
	3	N/A	4	FP ID LED+
	5	PWR_LED-	6	FP ID LED-
	7	P3V3	8	SYS_FLT_LED-
	9	SYS_ERR_LED-	10	M.2 SSD_ACT_LED-
	11	PWR_ON_BTN-	12	NIC1_LED+
	13	GND	14	NIC1_LED-
	15	SYS_RST_BTN-	16	SMB_DAT
	17	SMB_CLK	18	GND
	19	FP_ID_BTN-	20	N/A
	21	N/A	22	N/A
	23	NIC2_LED+	24	NIC2_LED-
	25	GND	26	GND

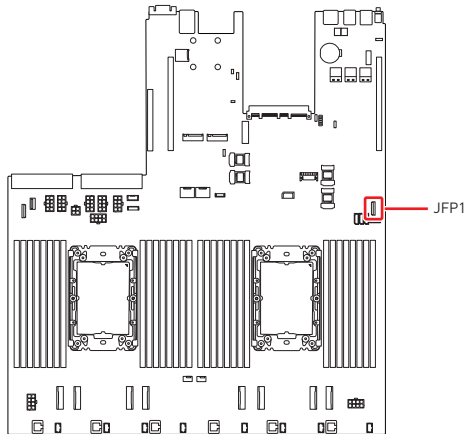

## JTPM1: SPI TPM Header

This header connects to a TPM (Trusted Platform Module) module (optional). Please refer to the TPM security platform manual for more details.

 <p>JTPM1</p>	1	N/A	2	SPI_PCH_CS0_N
	3	RST_RSMRST_N	4	N/A
	5	GND	6	P3V3_AUX
	7	SPI_PCH_CLK	8	SPI_PCH_IO2
	9	SPI_PCH_IO3	10	SPI_PCH_MISO
	11	N/A	12	SPI_PCH_MOSI
	13	SPI_PCH_TPM_DEDIPROG_CS_N	14	GND
	15	P3V3_AUX	16	N/A
	17	IRQ_TPM_SPI_N	18	P3V3_AUX
	19	RST_PLTRST_B_N	20	P3V3_AUX

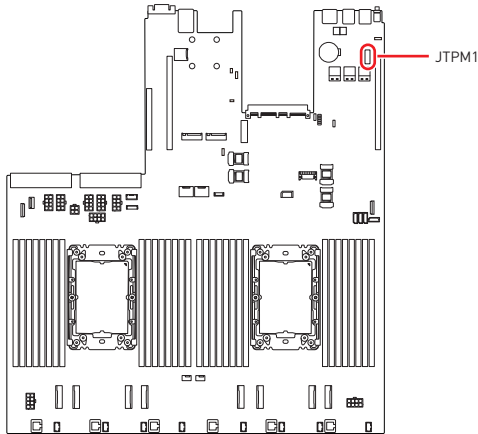

## JFP\_VGA1: Front VGA Header

The VGA header is provided for monitors.

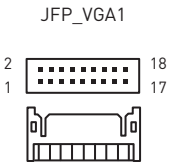
	1	N/A	2	N/A
	3	F_RED	4	GND
	5	F_GRN	6	GND
	7	F_BLU	8	GND
	9	F_VS	10	GND
	11	F_HS	12	GND
	13	F_DDCDAT	14	SEL_FP_N
	15	F_DDCCLK	16	F_VGA_5V
	17	N/A	18	N/A

## JIPMB1: IPMB Header

This header is used to connect the Intelligent Platform Management Bus.

	1	SMBUS_DATA
	2	GND
	3	SMBUS_CLK

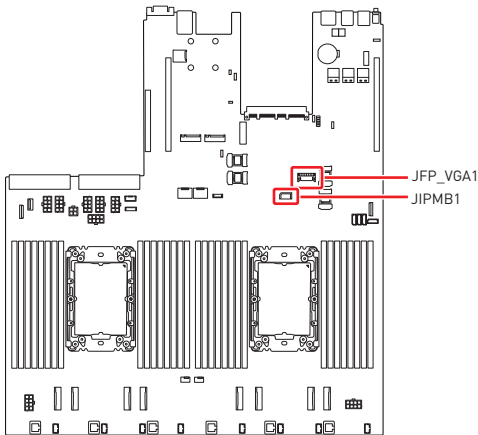

## JVROC1: VROC Header

Intel® Virtual RAID on CPU (Intel® VROC) is a RAID solution specifically designed for NVMe SSDs connected directly to the CPU.

JVROC1		1	GND	3	GND
		2	PU_KEY_CONN_PIN2_R	4	FM_PCH_SATA_RAID_KEY_R

## FP\_I2C\_1, BP\_I2C\_1~2: I2C Headers

These headers, known as I2C, are provided for users to connect System Management Bus (SMBus) interface.

FP_I2C_1 BP_I2C_1 BP_I2C_2		1	NC	3	GND
		2	SMB_CLK	4	SMB_DAT

## JSGPIO\_PCH1: Rear BP SGPIO Header

JSGPIO_PCH1		1	SGPIO_SATA_CLOCK_RBP	3	GND
		2	SGPIO_SATA_LOAD_RBP	4	SGPIO_SATA_DATAOUT_RBP

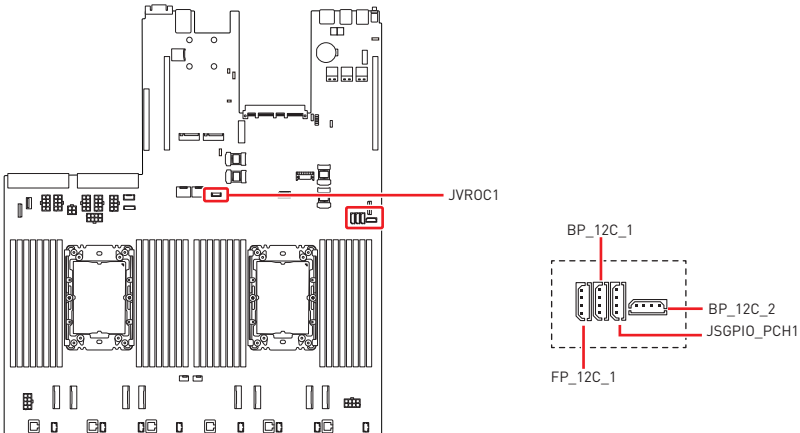

## JCHASSIS1: Chassis Intrusion Header

This header connects to the chassis intrusion switch cable. If the chassis is opened, the chassis intrusion mechanism will be activated. The system will record this status and show a warning message on the screen. To clear the warning, you must enter the BIOS utility and clear the record.

JCHASSIS1



Trigger the  
chassis intrusion  
event



Normal  
(default)

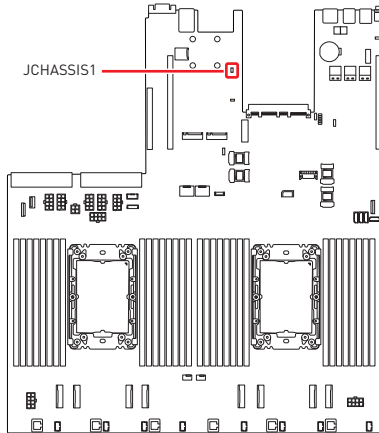

## BAT1: CMOS Battery

If the CMOS battery is out of charge, the time in the BIOS will be reset and the data of system configuration will be lost. In this case, you need to replace the CMOS battery.

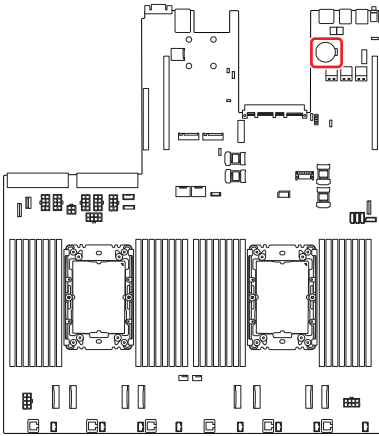

### Replacing CMOS battery

1. Push the retainer clip to free the battery.
2. Remove the battery from the socket.
3. Install the new CR2032 coin-cell battery with the + sign facing up. Ensure that the retainer holds the battery securely.

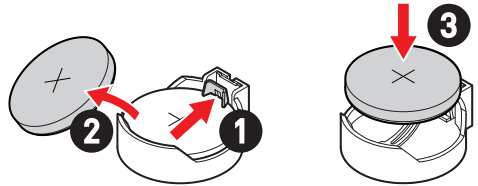

#### **WARNING**

#### **KEEP OUT OF REACH OF CHILDREN**

- Swallowing can lead to chemical burns, perforation of soft tissue, can death.
- Severe burns can occur within 2 hours of ingestion.
- If you think batteries might have been swallowed or placed inside any part of the body, seek immediate medical attention.





# Motherboard Jumpers

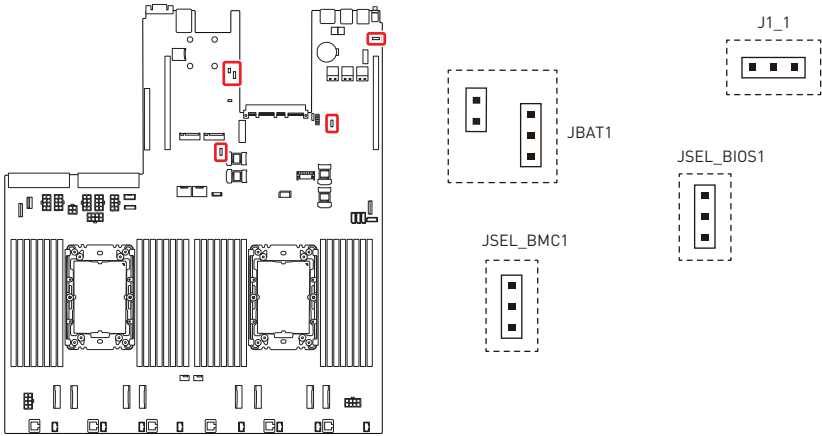

**Important**

Avoid adjusting jumpers when the system is on; it will damage the motherboard.



Jumper Name	Default Setting	Description
JSEL_BIOS1	 1	1-2: BIOS1 & allows BMC to switch (default) 2-3: BIOS2 (backup only, use when BIOS1 flash crashes)
JSEL_BMC1	 1	1-2: BMC1 (default) 2-3: BMC2
JBAT1	 1	1-2: Normal (default) 2-3: CMOS Clear
J1_1	 1	1-2: UID Button (default) 2-3: BMC Reset Button

# Motherboard LEDs

## LED1: BMC Heartbeat LED

This LED indicates the BMC (Baseboard Management Controller) status.

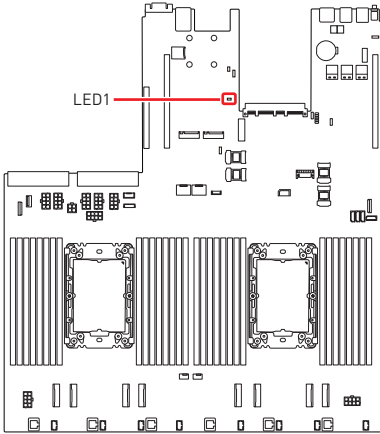

Status	Description
○ Off	BMC is not activated
● Blinking	BMC is functioning normally

## LED\_H1, LED\_L1: Port 80 Debug LEDs

The Port 80 debug LEDs display progress and error codes during and after POST (Power-On Self Test).

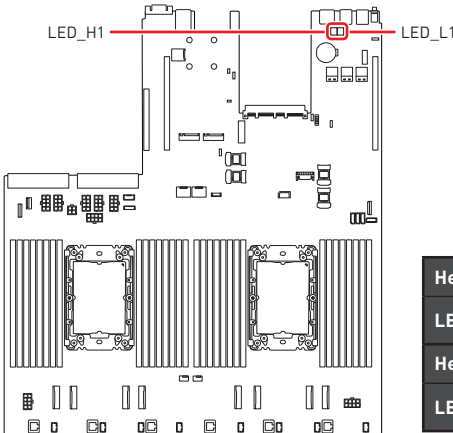

Hexadecimal Character Table

Hexadecimal	0	1	2	3	4	5	6	7
LED display	0	1	2	3	4	5	6	7
Hexadecimal	8	9	A	B	C	D	E	F
LED display	8	9	A	b	c	d	E	F

# Getting Started



- All information is subject to change without prior notice.
- The system photos are provided for demonstration purposes only. The appearance and internal view of your system may vary depending on the model you purchased.

## Necessary Tools

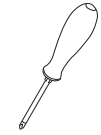

Screwdriver



Pliers



Tweezers



Anti-Static Gloves

## Safety Precautions

The following precautions should be observed while handling the system:

- Place the system on a flat and stable surface.
- Do not place the system in environments subject to mist, smoke, vibration, excessive dust, salty or greasy air, or other corrosive gases and fumes.
- Do not drop or jolt the system.
- Do not use a power adapter other than the one enclosed with the system.
- Disconnect the power cord before performing any installation procedures on the system.
- Do not perform any maintenance with wet hands.
- Prevent foreign substances, such as water, other liquids or chemicals, from entering the system while performing installation procedures.
- Use a grounded wrist strap before handling system components such as CPU, Memory, HDD, expansion cards, etc.
- Place system components on a grounded anti-static pad or on the bed that came with the components whenever the components are separated from the system.

# System Setup

## Important

Before removing or installing any components, make sure the system is not turned on or connected to the power.

## Drive Bay

### Installing 2.5" HDD/ SSD

1. Press the tray button to release the lever.
2. Pull the HDD/ SSD assembly out of the drive bay.
3. Insert the HDD/ SSD horizontally.

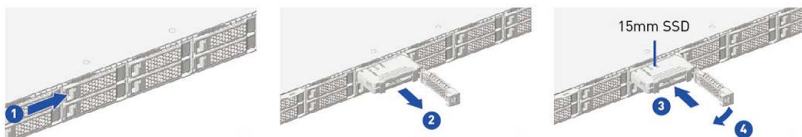

- The interposer BKT act as dummy HDD/ SSD when no drive inside.
- The interposer BKT act as spacer to support 7mm HDD/ SSD.

# System Cover

## Removing System Cover

1. Remove the **screws** securing the system on both sides.
2. To remove the top cover panels, press down on the **release latches** on both sides and then slide them to the front or back side of the system.

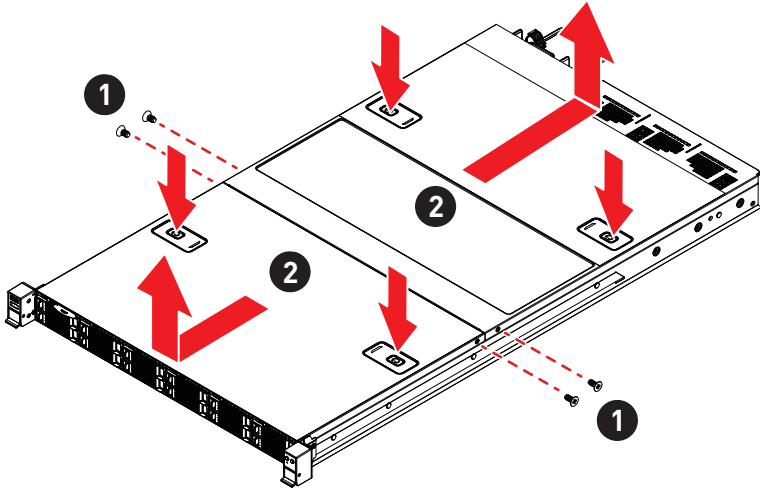

# CPU & Heatsink

Use appropriate ground straps, gloves and ESD mats to protect yourself from electrostatic discharge (ESD) while installing the processor.

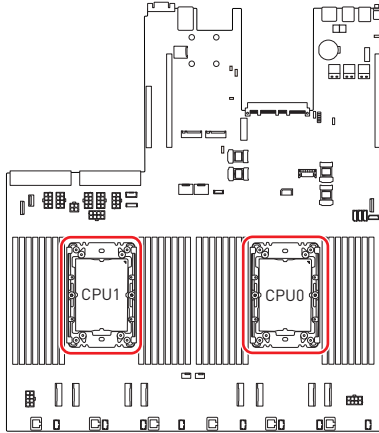

## **Important**

- While **replacing the CPU**, always turn off the power supply or unplug the power supply's power cord from the grounded outlet first to ensure the safety of CPU.
- **Overheating** will seriously damage the CPU and system. Always make sure the cooling fan can work properly to protect the CPU from overheating. Make sure to apply an even layer of thermal paste (or thermal tape) between the CPU and the heatsink to enhance heat dissipation.
- Please check the instruction that come with your heatsink and thermal paste for more details before starting.

## Assembly Overview

### Important

Images are for illustration purposes only; actual parts may vary.

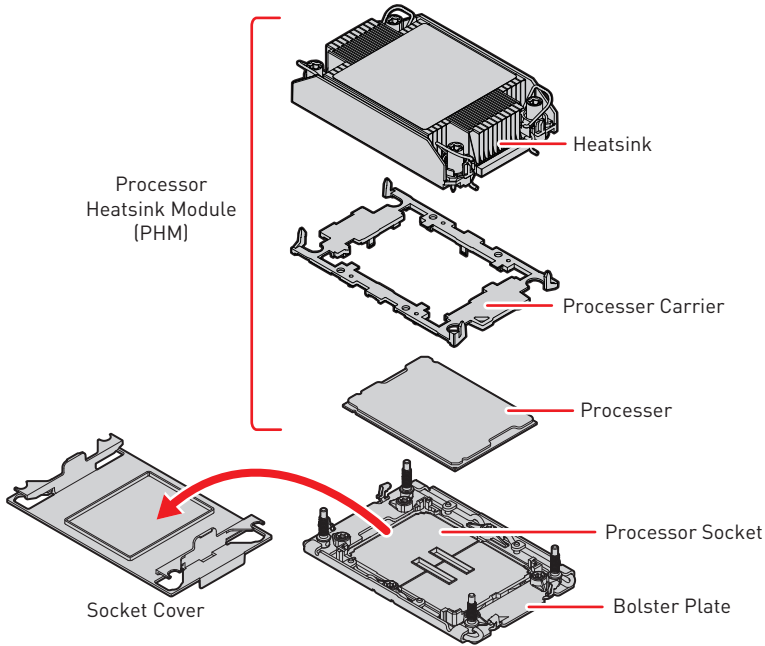

### Important

- Confirm if your heatsink is firmly installed before turning on your system.
- Whenever CPU is not installed, always protect your CPU socket pins with the plastic cap covered.
- Do not touch the CPU socket pins to avoid damage.
- Read the CPU status in BIOS.

## Installing CPU & Heatsink

1. Place the processor carrier on top of the processor in the tray with their **pin 1 indicators aligned**. If installed properly, the CPU will snap into the carrier's side latches and the carrier will latch firmly to it.

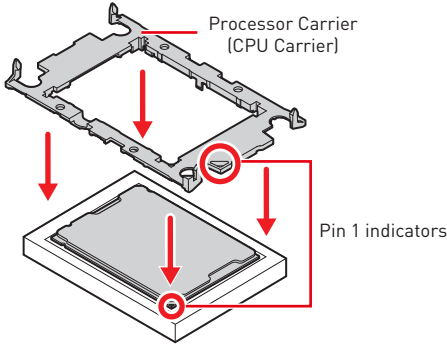

### **Important**

Please refer to the following table for the corresponding CPU carrier.

CPU Package Type	CPU Carrier Code
Sapphire Rapids- SP XCC Emerald Rapids- SP XCC	E1A
Sapphire Rapids- SP MCC Emerald Rapids- SP MCC Sapphire Rapids EE	E1B
Sapphire Rapids + HBM	E1C

2. Remove the **protective film** at the bottom of the heatsink if any.
  - To avoid damaging the fins of the heatsink, always grip the heatsink along the axis of the fins. Holding a heatsink along the side might damage its fins or solder.
3. Make sure the heatsink has pre-applied thermal paste. If there isn't, you'll need to apply thermal paste to the bottom center of the heatsink.

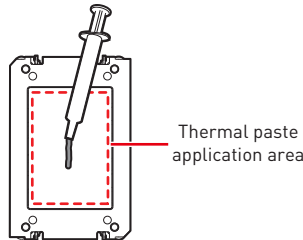

4. Check the heatsink for a diagonally cut corner or the #1 clip on the heatsink label if present. Align the **processor Carrier's Pin 1 indicator** with the **heatsink's cut corner (#1 clip)**, then gently press the heatsink down to engage the carrier's latching mechanism to the heatsink at four corners.

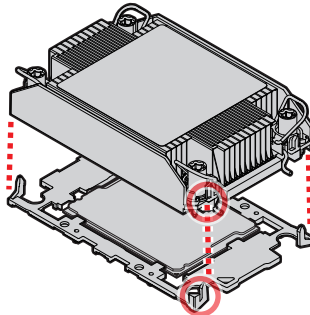

5. Make sure the attached clips on the carrier grab onto the heatsink and firmly secure the carrier, CPU and heatsink as one **Processor Heatsink Module (PHM)**.
6. Remove the socket cover by squeezing the finger grips in, then flip **4 anti-tilt wires** on the heatsink to the **unlocked position (inward)** and place the PHM on top of the bolster plate with the Pin 1 indicators aligned. Hold the PHM horizontally, carefully lower down to engage PHM to bolster the plate's alignment pin.

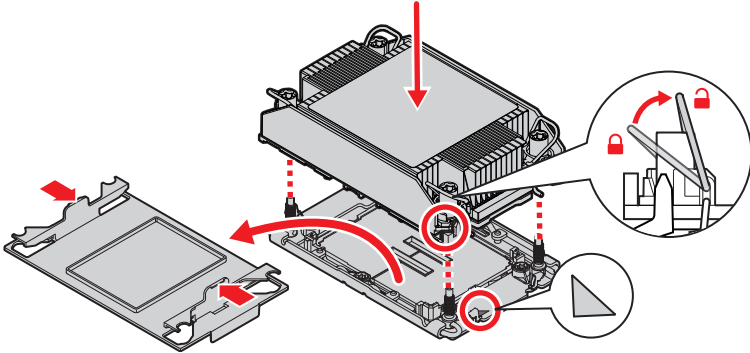

7. Flip 4 anti-tilt wires to the **locked position (outward)** and make sure the latches of the wires are firmly secure.

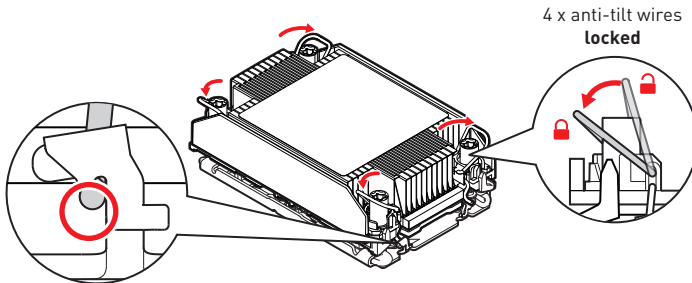

8. Tighten all screws on the PHM in diagonal sequences to secure the PHM to the motherboard. [Torque: 0.904 N·m, 0.904 N·m = 9.2208 kgf·cm = 8 lbf·in ]
  - To avoid distributing uneven pressure on the CPU, it is recommended to secure the PHM in two steps: first, loosely attach the screws at four points and then gradually tighten them.

# Memory

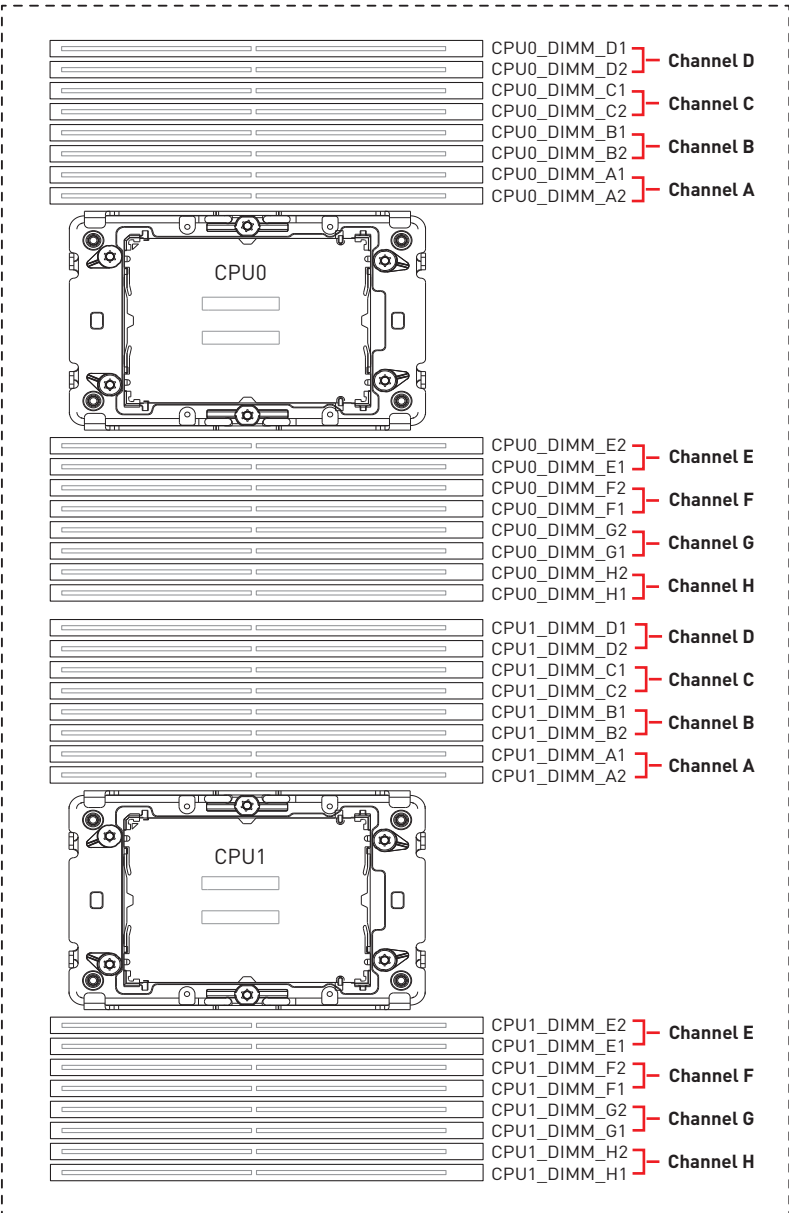

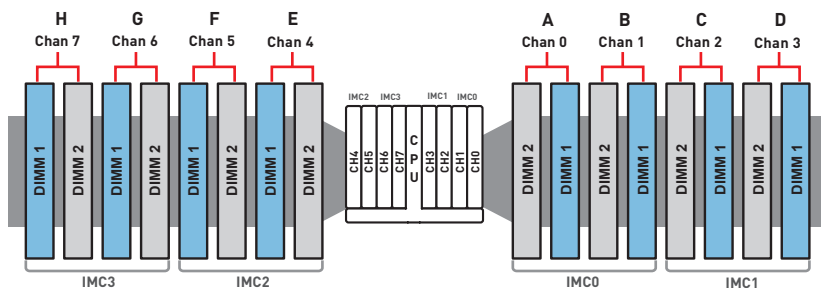

## Recommended Memory Population

### Key Parameters for DIMM Configurations

Parameter	Possible Values		
# of Channels Per Socket	1, 2, 4, 6, 8		
# of DIMMs Populated Per Channel	1DPC or 2DPC		
DIMM Type	RDIMM, 3DS RDIMM, 9x4 RDIMMs		
DIMM Construction	Non-3DS RDIMM Raw Cards	A	2Rx4
		C	1Rx4
		D	1Rx8
		E	2Rx8
	3DS RDIMM Raw Cards	A	4Rx4
			8Rx4
9x4 RDIMM Raw Cards	B	2Rx4	
		F	1Rx4

## DDR5 Only DIMM Configuration

SPR IMC#	IMC3				IMC2				IMC0				IMC1			
Channel	H		G		F		E		A	B		C		D		
	Chan 7		Chan 6		Chan 5		Chan 4		Chan 0		Chan 1		Chan 2		Chan 3	
DDR5	H1	H2	G1	G2	F1	F2	E1	E2	A2	A1	B2	B1	C2	C1	D2	D1
1+0							V		V							
					V						V					
								V								
2+0			V						V							
								V								
4+0			V					V								
									V							
6+0	V		V		V		V		V				V		V	
	V		V		V		V		V		V		V		V	
	V		V		V		V		V		V		V		V	
	V		V		V		V		V		V		V		V	
8+0	V		V		V		V		V		V		V		V	
	V		V		V		V		V		V		V		V	
12+0	V	V	V	V	V	V	V	V	V	V	V	V	V	V	V	V
	V	V	V	V	V	V	V	V	V	V	V	V	V	V	V	V
16+0	V	V	V	V	V	V	V	V	V	V	V	V	V	V	V	V
	V	V	V	V	V	V	V	V	V	V	V	V	V	V	V	V

"V" indicates DIMMs are populated with DDR5.



### Note

1. There should be at least one DDR5 DIMM per socket.
2. Interleaving way limitations: 3-way Channel and 3-Way Rank interleaving are not supported. A 2-Way + A 1-Way would be implemented instead of A 3-Way for those channel DIMM configurations. A 2-way interleave method is implemented across 3 ranks in a channel.
3. Sapphire Rapids processor erratum prevents using 6-way Hemisphere mode, 6-way All-to-All mode would be the default for 6 channel configurations.
4. If the system detects a DIMM fails at boot time, BIOS takes map-out actions for a fallback to the nearest reduced POR config in the table.
5. Rank sparing, ADDDC, channel mirroring, and Hemisphere/quad modes are not supported with SGX.
6. SPR+HBM does not support Hemisphere/SNC2 modes.
7. UMA default - see 6-DIMM configurations, x6 interleaving for All-to-All mode.

## Installing Memory Modules

1. Open the side clips to unlock the DIMM slot.
2. Insert the DIMM vertically into the slot, ensuring that the off-center notch at the bottom aligns with the slot.
3. Push the DIMM firmly into the slot until it clicks and the side clips automatically close.
4. Verify that the side clips have securely locked the DIMM in place.

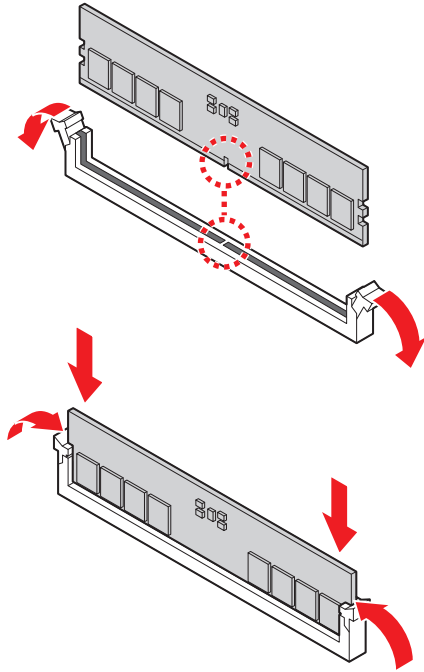

### **Important**

*You can barely see the golden finger if the memory module is properly inserted in the DIMM slot.*

# M.2 M Key

## Installing M.2 M Key



### Video Demonstration

Watch the video to learn how to install M.2 SSD.



1. Loosen the M.2 riser screw from the motherboard.
2. Move and fasten the M.2 riser screw to the appropriate location according to your M.2 SSD size.
3. Insert your M.2 SSD into the M.2 slot at a 30-degree angle.
4. Secure the M.2 SSD in place with the supplied M.2 screw.

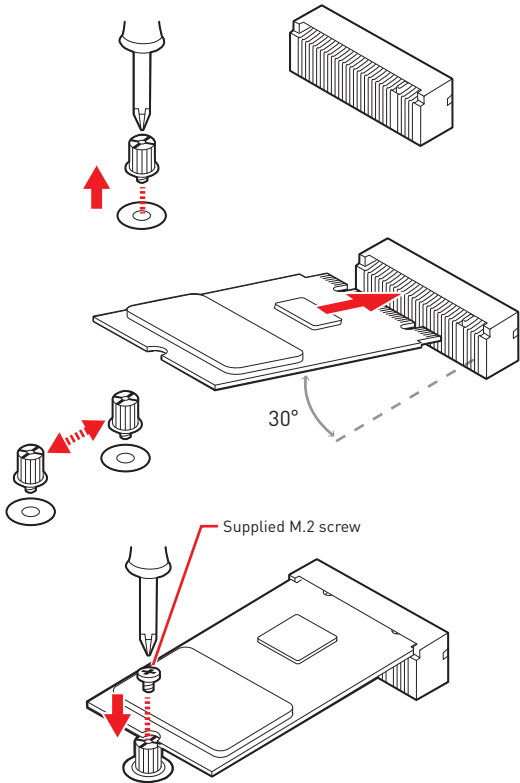

# PCIe Add-in Card

## Installing PCIe Add-in Card

1. Loosen the screws on the riser bracket to remove the filler panels.
2. Align the PCIe add-in card with the connector on the riser card, and insert it until it is fully seated.
3. Tighten the screws to securely fix the PCIe add-in card in place.



The procedure for installing PCIe add-in cards are the same for all riser slots.

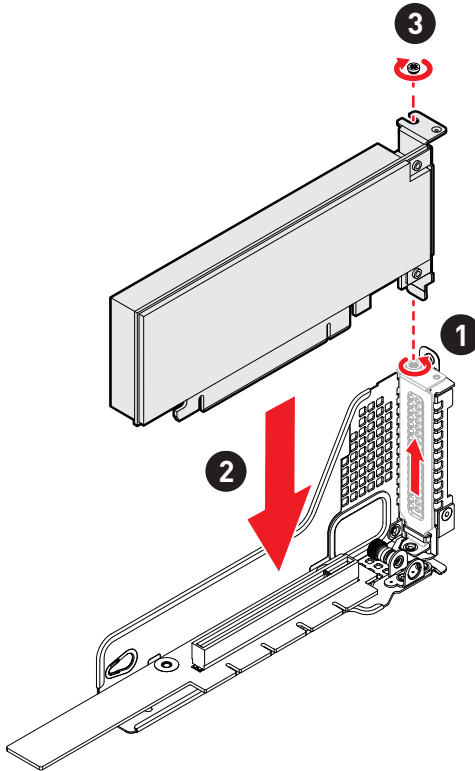

## Installing Riser Card Assembly

1. Make sure the **key slots on the rear edge of the riser card** assembly are aligned with the **mounting pins on the rear edge of the system** (indicated by the red circle in the image below).
2. Insert the riser card assembly into the PCIe slot on the system board.
3. Tighten the screws on the rear side of the system to secure the riser card assembly.

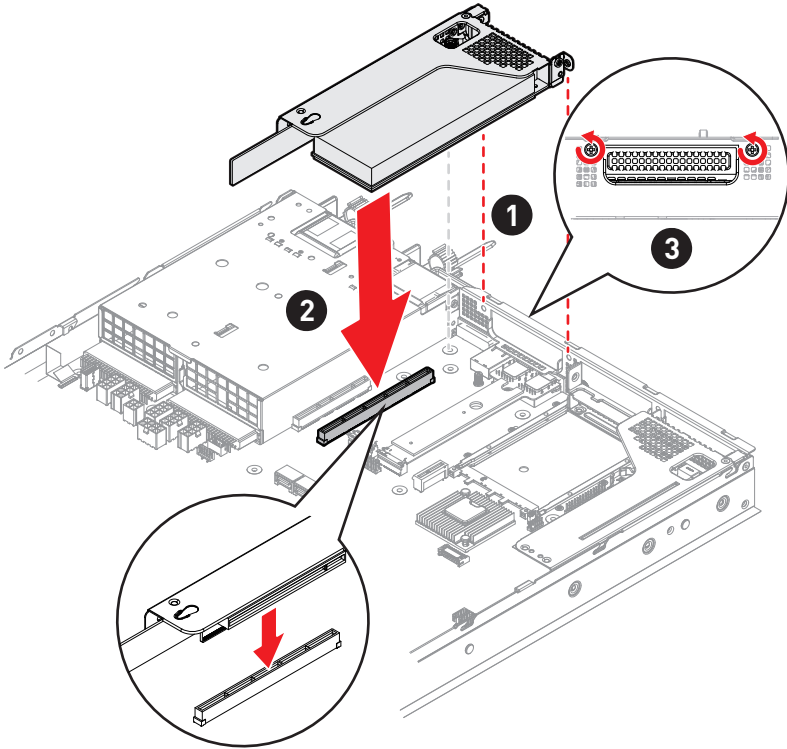

# System Fan

The server system is equipped with **8 non-hot swappable system fans** that measure **40 x 40 x 56mm**, which provide primary airflow to maintain optimal cooling and prevent overheating.

## The fan features include:

- Tachometer on each fan allows BMC to monitor the system's status in real-time.
- An integrated BMC firmware automatically adjusts fan speed based on the system's thermal status to maintain optimal performance.

## Installing 1U Fan

1. Lower the system fan until it seated firmly.
  2. Connect the fan cable to the system board.
- *Note the fool-proof design on the connector before docking it.*

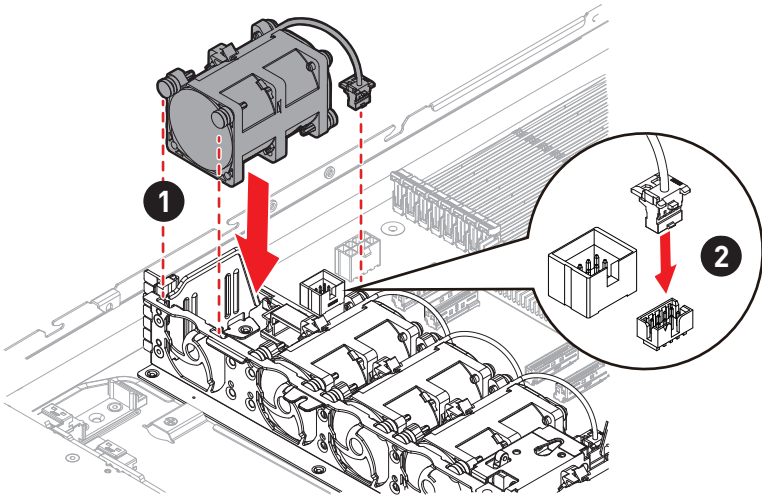

# Power Supply Unit (PSU)

The server system supports two power supplies that can be easily inserted and removed from the rear side of the system without the need for tools.

## Important

- Both power supplies must be identical and both power cords should be connected.
- Failing to connect both power supplies could result in CPU throttling.

## Installing PSU

1. Remove the PSU blank.
2. Slide the PSU into the chassis bay until the release latch snaps into place.
3. Connect the power cable to the PSU power outlet.

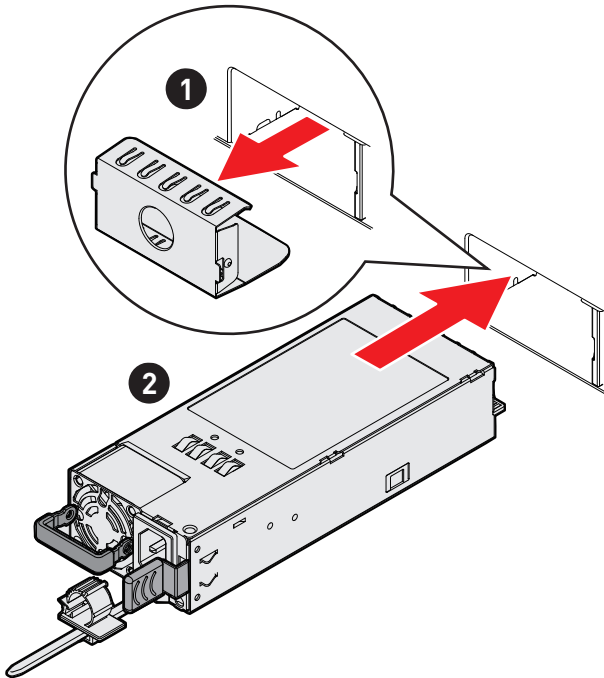

# Cable Routing



**Important**

Please remove the **fan cage** before routing cables.

## I2C Cable

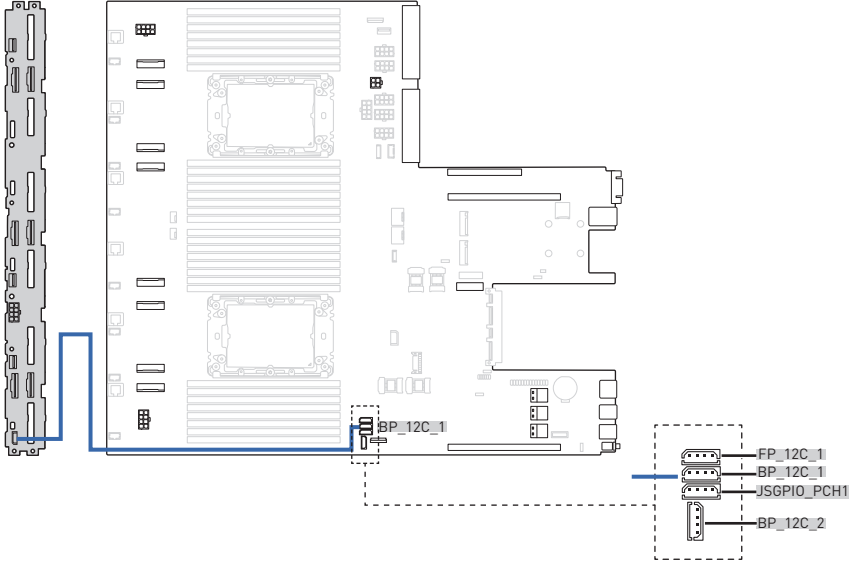

## 8-pin to 8-pin Power Cable



## MCIO 8i to SlimlineSAS 8i Cable

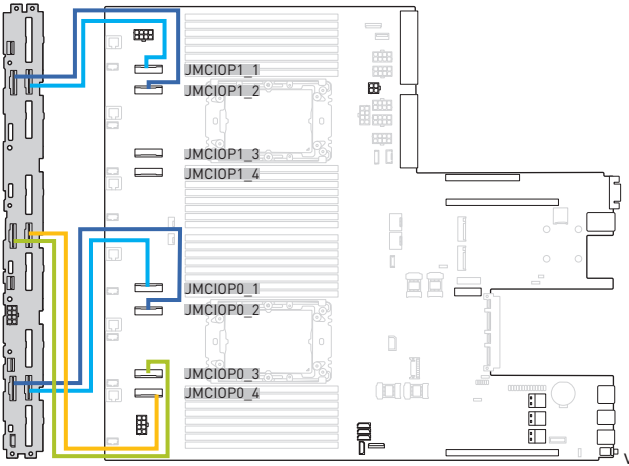

## SlimlineSAS 8i to SlimlineSAS 8i Cable

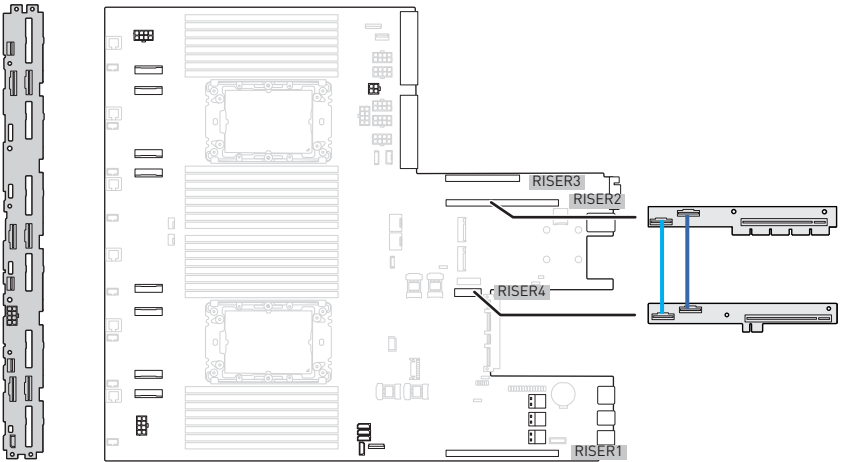

# Slide Rail



**Important**

The pre-installed screws on the outer rail bracket are intended only for square rack holes. For round holes, please switch to the "7.1 round hole screw".

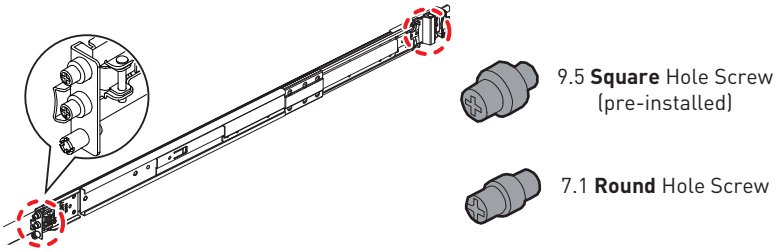

## Disassembling Slide Rail

Slide the **release tab** forward to separate the inner rail from the bracket.

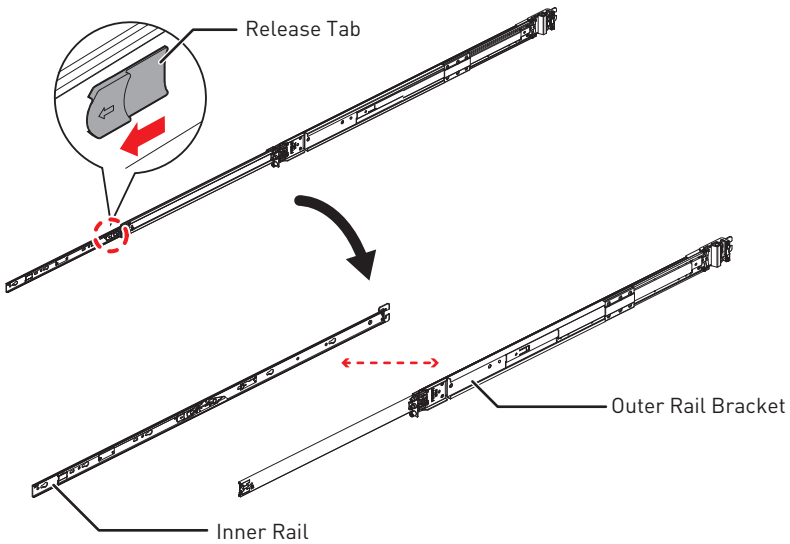

## Installing Inner Rail to System

1. Align the standoffs on the side of the system with the hole on the inner rail, then **pull the inner rail backwards** till it locks into place.
2. Tighten the screw to secure the inner rail.
3. Repeat the same procedure to install the inner rail on the other side of the system.

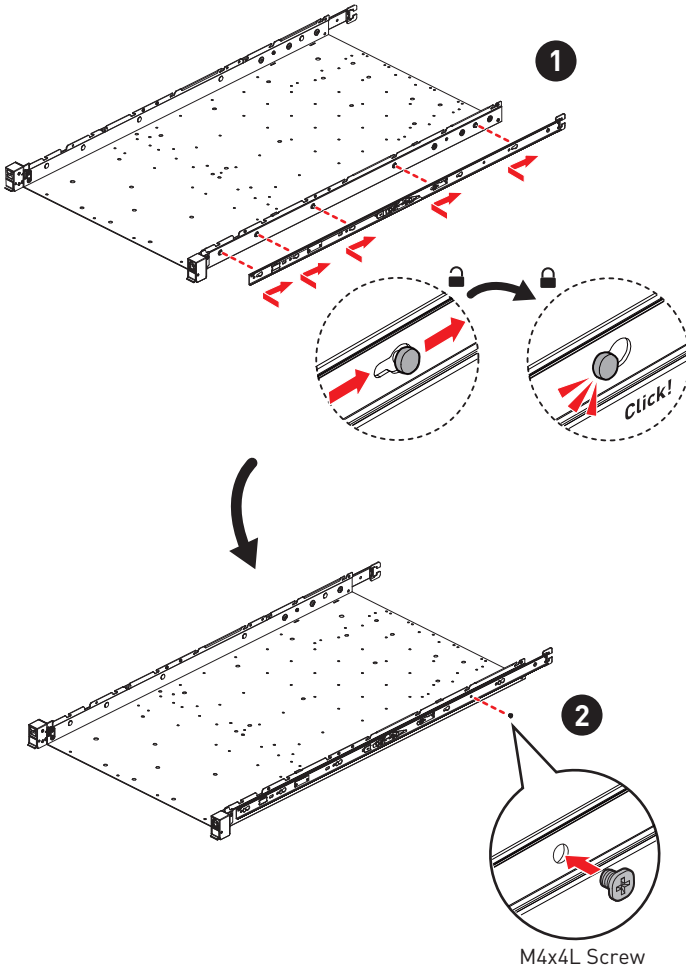

## Retracting Outer Rail Bracket

Pull the latch downward to slide the middle rail back to the outer rail bracket.

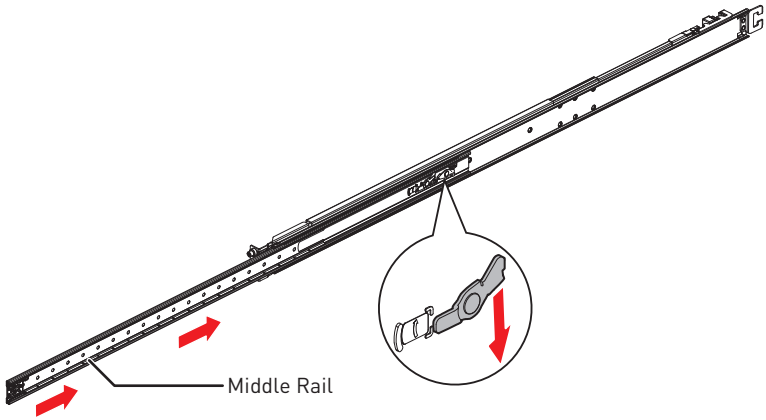

## Attaching Outer Rail Bracket to Rack Frame

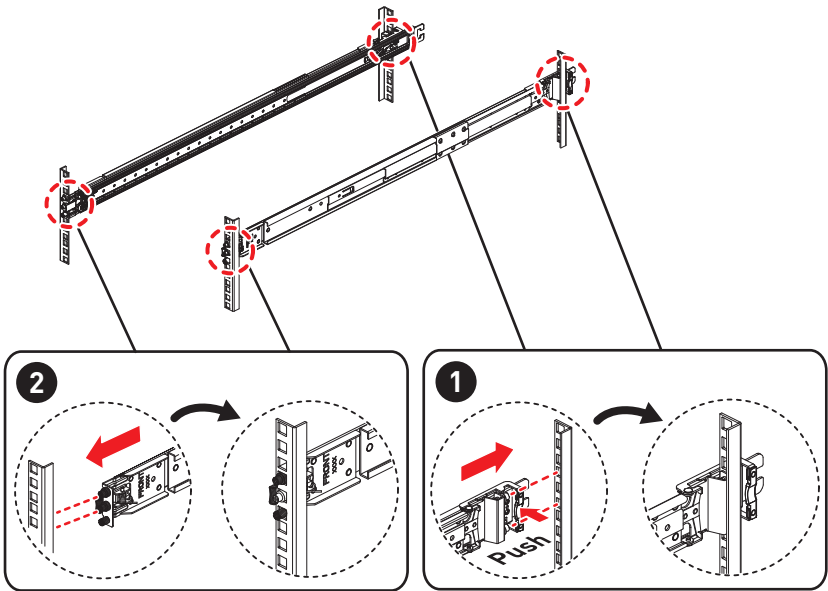

## Installing System into Rack

1. Pull out the middle rails till it fully extended.
2. Engage the inner rails of the system to the middle rails, then push the system forward until it stops.
3. Push the system into the rack by sliding the **two-way release tabs** forward or backward.
4. Tighten the screws to secure the system.



**Important**

Ensure the ball bearing retainers are locked forward on each middle rail.

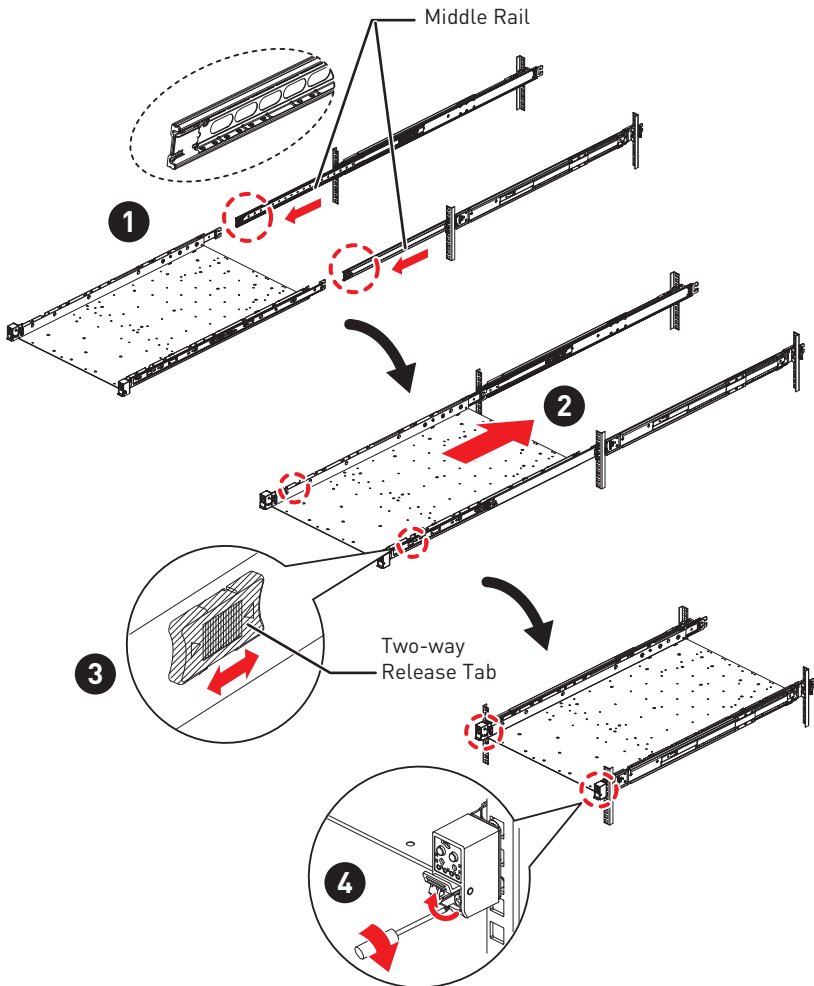

## Detaching Outer Rail Bracket from Rack Frame

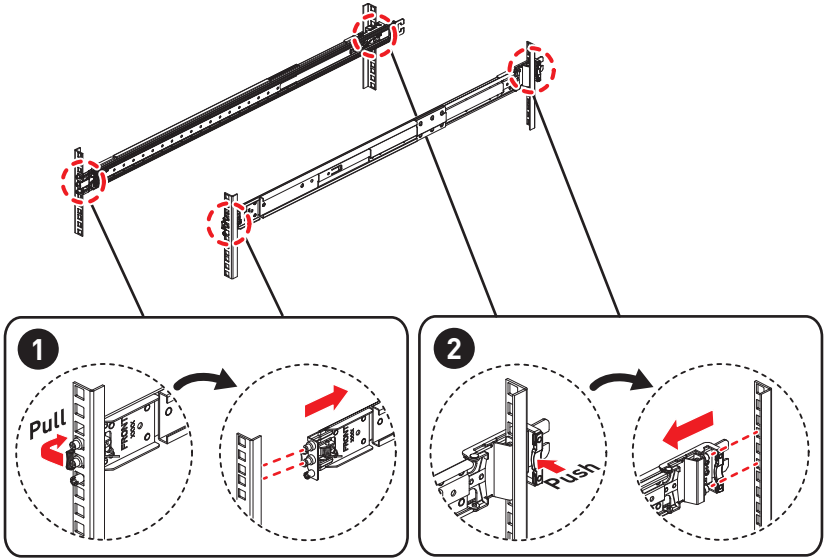

## Detaching Inner Rail from System

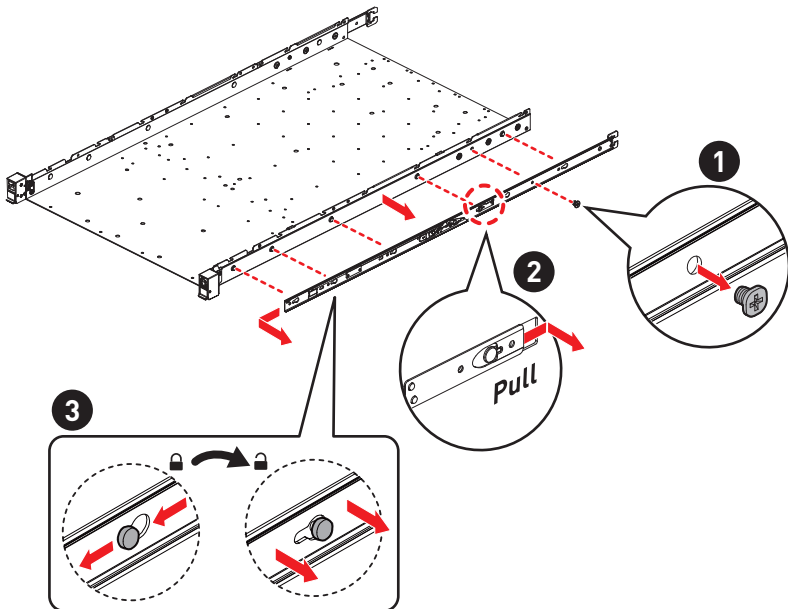



[MSI.COM](https://www.msi.com)



[EPS.MSI.COM](https://www.msi.com/eps)