

H310I-IM-A R3.0



Industrial Motherboard

Copyright © 2024 ASUSTeK COMPUTER INC. All Rights Reserved.

No part of this manual, including the products and software described in it, may be reproduced, transmitted, transcribed, stored in a retrieval system, or translated into any language in any form or by any means, except documentation kept by the purchaser for backup purposes, without the express written permission of ASUSTeK COMPUTER INC. ("ASUS").

Product warranty or service will not be extended if: (1) the product is repaired, modified or altered, unless such repair, modification or alteration is authorized in writing by ASUS; or (2) the serial number of the product is defaced or missing.

ASUS PROVIDES THIS MANUAL "AS IS" WITHOUT WARRANTY OF ANY KIND, EITHER EXPRESS OR IMPLIED, INCLUDING BUT NOT LIMITED TO THE IMPLIED WARRANTIES OR CONDITIONS OF MERCHANTABILITY OR FITNESS FOR A PARTICULAR PURPOSE. IN NO EVENT SHALL ASUS, ITS DIRECTORS, OFFICERS, EMPLOYEES OR AGENTS BE LIABLE FOR ANY INDIRECT, SPECIAL, INCIDENTAL, OR CONSEQUENTIAL DAMAGES (INCLUDING DAMAGES FOR LOSS OF PROFITS, LOSS OF BUSINESS, LOSS OF USE OR DATA, INTERRUPTION OF BUSINESS AND THE LIKE), EVEN IF ASUS HAS BEEN ADVISED OF THE POSSIBILITY OF SUCH DAMAGES ARISING FROM ANY DEFECT OR ERROR IN THIS MANUAL OR PRODUCT.

SPECIFICATIONS AND INFORMATION CONTAINED IN THIS MANUAL ARE FURNISHED FOR INFORMATIONAL USE ONLY, AND ARE SUBJECT TO CHANGE AT ANY TIME WITHOUT NOTICE, AND SHOULD NOT BE CONSTRUED AS A COMMITMENT BY ASUS. ASUS ASSUMES NO RESPONSIBILITY OR LIABILITY FOR ANY ERRORS OR INACCURACIES THAT MAY APPEAR IN THIS MANUAL, INCLUDING THE PRODUCTS AND SOFTWARE DESCRIBED IN IT.

Products and corporate names appearing in this manual may or may not be registered trademarks or copyrights of their respective companies, and are used only for identification or explanation and to the owners' benefit, without intent to infringe.

Contents

Chapter 1 Product overview

| | | |
|-----|-----------------------|-----|
| 1.1 | Package contents..... | 1-1 |
| 1.2 | Features | 1-1 |
| 1.3 | Specifications..... | 1-2 |

Chapter 2 Motherboard information

| | | |
|-------|---|------|
| 2.1 | Before you proceed | 2-1 |
| 2.2 | Motherboard layout..... | 2-2 |
| 2.3 | Central Processing Unit (CPU) | 2-4 |
| 2.3.1 | CPU installation | 2-5 |
| 2.3.2 | CPU heatsink and fan assembly installation..... | 2-7 |
| 2.4 | System memory | 2-9 |
| 2.5 | Jumpers | 2-10 |
| 2.6 | Connectors | 2-12 |
| 2.6.1 | Rear panel connectors..... | 2-12 |
| 2.6.2 | Internal connectors | 2-15 |
| 2.7 | Slot | 2-24 |

Chapter 3 BIOS setup

| | | |
|--------|------------------------------------|------|
| 3.1 | BIOS Setup program..... | 3-1 |
| 3.2 | Main menu | 3-2 |
| 3.2.1 | System Date [Day MM/DD/YYYY] | 3-2 |
| 3.2.2 | System Time [HH:MM:SS] | 3-2 |
| 3.3 | Advanced menu | 3-2 |
| 3.3.1 | LVDS Configuration | 3-2 |
| 3.3.2 | PCH-FW Configuration | 3-4 |
| 3.3.3 | Trusted Computing | 3-4 |
| 3.3.4 | CPU Configuration | 3-5 |
| 3.3.5 | Graphics Configuration | 3-5 |
| 3.3.6 | PCI Express Configuration..... | 3-6 |
| 3.3.7 | CSM Configuration..... | 3-6 |
| 3.3.8 | Supper IO Configuration | 3-6 |
| 3.3.9 | Serial Console Redirection | 3-7 |
| 3.3.10 | SATA Configuration | 3-9 |
| 3.3.11 | USB Configuration | 3-10 |
| 3.3.12 | Onboard Devices Configuration..... | 3-11 |

| | | |
|---------------------|-----------------------------------|-------------|
| 3.3.13 | NVMe Configuration..... | 3-11 |
| 3.3.14 | APM Configuration..... | 3-12 |
| 3.3.15 | EZ-Flash | 3-12 |
| 3.3.16 | Watchdog Timer..... | 3-12 |
| 3.3.17 | Miscellaneous | 3-12 |
| 3.4 | Hardware Monitor menu..... | 3-13 |
| 3.5 | Security menu | 3-14 |
| 3.5.1 | Administrator Password..... | 3-14 |
| 3.5.2 | User Password..... | 3-14 |
| 3.5.3 | Secure Boot | 3-15 |
| 3.6 | Boot menu | 3-15 |
| 3.7 | Exit menu..... | 3-16 |
| Appendix | | |
| | Notices..... | A-1 |
| | Service and Support..... | A-5 |

Chapter 1

Product overview

1.1 Package contents

Check your industrial motherboard package for the following items.

- 1 x ASUS H310I-IM-A R3.0 Motherboard
- 2 x Serial ATA 6.0 Gb/s cables
- 2 x M.2 screw packages
- 1 x ASUS I/O Shield



NOTE: If any of the above items is damaged or missing, contact your distributor or sales representative immediately.

1.2 Features

- Intel® socket 1151 for 9th/8th Gen Intel® Core™ i7/ i5/ i3, Pentium®, and Celeron® processors supports 14nm CPU, Max. 65W TDP
- Two Dual Channel DDR4 2666/2400/2133MHz SO-DIMMs up to 32GB
- 2 x SATA 6.0 Gb/s, 6 x USB 3.2 Gen 1, 4 x USB 2.0, 6 x COM headers
- 1 x PCIe x16 slot, 1 x MiniPCIe, 1 x M.2 Socket 1 (Key E, 2230) for WIFI/ BT device, 1 x M.2 Socket 3 (Key M, 2242/2260/2280) with PCIe and SATA modes for SSD
- Multi-display: 2 x DisplayPort, 1 x HDMI, LVDS

1.3 Specifications

| | |
|-----------------------------|--|
| CPU | <p>Intel® socket 1151 for 9th/8th Gen Intel® Core™ i7/ i5/ i3, Pentium®, and Celeron® processors, Max.65 TDP</p> <p>Supports Intel® 14nm CPU</p> <p>* Refer to www.asus.com for Intel® CPU support list.</p> |
| Chipset | Intel® H310 Chipset |
| Memory | <p>2 x SO-DIMM, max.32GB, DDR4 2666/2400/2133 MHz</p> <p>* Refer to www.asus.com for the latest Memory QVL (Qualified Vendors List).</p> |
| Graphics | <p>Integrated graphics processor - Intel® HD Graphics support</p> <p>Multi-VGA output support: DP/HDMI/LVDS ports</p> <ul style="list-style-type: none"> - Supports HDMI1.4b output with a max. resolution of 4096 x 2160 @ 24Hz - Supports 2 x DisplayPort 1.2a outputs with a max. resolution of 4096 x 2160 @ 60 Hz - Supports LVDS 1.4b output with a max. resolution of 1920 x 1200 @ 60Hz |
| Expansion slots | <p>1 x PCI Express 3.0/2.0 x16 slot</p> <p>1 x Full/Half mini-PCIe with SATA</p> <p>1 x M.2 Socket 1 (Key E, 2230) for WIFI/BT device</p> <p>1 x M.2 Socket 3 (Key M, 2242/2260/2280) with PCIe and SATA modes for SSD</p> |
| Storage | <p>2 x SATA 6.0 Gb/s ports</p> <p>1 x M.2 Socket 3 (Key M, 2242/2260/2280) with PCIe and SATA modes for SSD</p> <p>1 x full/half mini-PCIe with SATA</p> |
| LAN | Dual Intel® Lan: 1 x Intel® I219V, 1 x Intel® I210AT |
| Audio | <p>Realtek® ALC897 8-channel High Definition Audio CODEC*</p> <ul style="list-style-type: none"> - Supports Jack-Detection, Multi-recording, and Audio Re-tasking <p>* The audio codec may vary between motherboards, please consult your sales window for the motherboard's exact codec type.</p> |
| USB | <p>4 x USB 3.2 Gen 1 ports (4 ports at the rear panel)</p> <p>1 x USB 3.2 Gen 1 header (2 USB 3.2 Gen 1 ports at mid-board)</p> <p>2 x USB 2.0 headers (for 4 USB 2.0 ports at mid-board)</p> |
| Rear panel I/O ports | <p>1 x HDMI port</p> <p>2 x DisplayPorts</p> <p>2 x COM ports (2 x RS232/422/485)</p> <p>2 x LAN (RJ45) ports</p> <p>4 x USB 3.2 Gen 1 ports</p> <p>2 x Audio jacks</p> |

(continued on the next page)

| | |
|----------------------------------|--|
| Front panel I/O ports | <p>2 x USB 2.0 2-port connectors support additional 4 USB 2.0 ports</p> <p>1 x USB 3.2 Gen 1 2-port connector supports additional 2 USB 3.2 Gen 1 ports</p> <p>2 x SATA 6.0Gb/s connectors</p> <p>1 x M.2 Socket 1 (Key E, 2230) for WIFI/BT device</p> <p>1 x M.2 Socket 3 (Key M, 2242/2260/2280) for SSD</p> <p>1 x Full/Half mini-PCIe with SATA</p> <p>1 x CPU Fan connector</p> <p>1 x Chassis Fan connector</p> <p>1 x Front panel audio connector (AAFP)</p> <p>1 x System panel connector</p> <p>1 x Clear CMOS header</p> <p>4 x COM headers (4 x RS232)</p> <p>1 x SPI TPM header</p> <p>1 x LPC Debug header</p> <p>1 x Speaker connector</p> <p>1 x 24-pin ATX power connector</p> <p>1 x 4-pin ATX power connector</p> <p>1 x LVDS connector</p> <p>1 x LCD panel monitor switch header</p> <p>1 x Display panel VCC power selector</p> <p>1 x Flat panel display brightness connector</p> <p>1 x AT/ATX mode selection header</p> |
| GPIO | 1 x 8-bit GPIO header |
| BIOS features | 128 Mb Flash ROM, UEFI AMI BIOS, PnP, DMI 3.0, WfM 2.0, SM BIOS 3.1, ACPI 6.1, Multi-language BIOS, ASUS EZ Flash 3, Last Modified Log, ErP Ready, ASUS Self-Recovering BIOS, ASUS Commercial Kit |
| Manageability | WfM 2.0, DMI 2.0, WOL by PME |
| Watch dog timer | Yes |
| Power requirement | AT/ATX |
| Operation Temperature | 0~60°C |
| Non-Operation Temperature | -40~85°C |
| Relative Humidity | 0%~85% |

(continued on the next page)

| | |
|--------------------|--|
| OS support | Windows® 10 (64-bit) |
| | Win10 IoT Enterprise |
| | Ubuntu |
| | RedHat Enterprise |
| | Fedora Workstation |
| | OpenSUSE |
| Form Factor | Mini-ITX Form Factor, 6.7"x 6.7" (17.0cm x 17.0cm) |



NOTE: Specifications are subject to change without notice. Please refer to the ASUS website for the latest specifications.

Chapter 2

Motherboard information

2.1 Before you proceed

Take note of the following precautions before you install motherboard components or change any motherboard settings.



CAUTION!

- Unplug the power cord from the wall socket before touching any component.
 - Before handling components, use a grounded wrist strap or touch a safely grounded object or a metal object, such as the power supply case, to avoid damaging them due to static electricity.
 - Hold components by the edges to avoid touching the ICs on them.
 - Whenever you uninstall any component, place it on a grounded antistatic pad or in the bag that came with the component.
 - Before you install or remove any component, always remove the AC power by unplugging the power cord from the power outlet. Failure to do so may cause severe damage to the motherboard, peripherals, or components.
-

| Connectors/Jumpers/Slots | | Page |
|---------------------------------|---|-------------|
| 1. | COM1 Ring/+5V/+12V selection jumpers (6-pin COM1_ESL, COM2_ESL) | 2-11 |
| 2. | LCD panel monitor switch header (2-pin PANEL_SW) | 2-15 |
| 3. | USB 3.2 Gen 1 connector (20-pin U32G1_12) | 2-15 |
| 4. | USB 2.0 connectors (10-pin USB56, USB78) | 2-16 |
| 5. | General purpose input/output connector (GPIO_CON) | 2-16 |
| 6. | Serial port connectors (10-1 pin COM3, COM4, COM5, COM6) | 2-22 |
| 7. | TPM connector (14-1 pin TPM) | 2-17 |
| 8. | Display panel backlight power selection (3-pin BLKT_PWR_SEL) | 2-10 |
| 9. | LVDS connector (40-pin LVDS) | 2-19 |
| 10. | DDR4 SO-DIMM slots | 2-9 |
| 11. | Display panel VCC power selection (6-pin VCC_PWR_SEL) | 2-11 |
| 12. | ATX power connectors (24-pin EATXPWR, 4-pin ATX12V) | 2-22 |
| 13. | Flat panel display brightness connector (8-pin LCD_BLKT_PANEL) | 2-23 |
| 14. | Serial ATA 6.0Gb/s connectors (7-pin SATA6G_1/2) | 2-18 |
| 15. | System panel connector (10-1 pin F_PANEL) | 2-18 |
| 16. | Speaker connector (4-pin SPEAKER) | 2-19 |
| 17. | CPU and chassis fan connectors (4-pin CPU_FAN, 4-pin CHA_FAN) | 2-17 |
| 18. | AT/ATX mode selection (3-pin AT_ATX_SEL) | 2-12 |
| 19. | PCI Express 3.0/2.0 x16 slot | 2-24 |
| 20. | Clear RTC RAM (2-pin CLRRTC) | 2-10 |
| 21. | Front panel audio connector (10-1 pin AAFP) | 2-23 |
| 22. | Intel® LGA1151 CPU socket | 2-4 |
| 23. | M.2 socket 3 | 2-20 |
| 24. | mSATA/mPCIe combo slot (MSATA_MPCIE) | 2-21 |
| 25. | M.2 Wi-Fi | 2-20 |
| 26. | LPC debug header | 2-21 |

2.3 Central Processing Unit (CPU)

The motherboard comes with a surface mount LGA1151 socket designed for the Intel® 9th/8th Generation Core™ i7 / Core™ i5 / Core™ i3, Pentium®, and Celeron® processors.

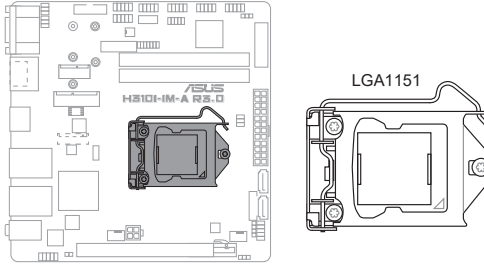

IMPORTANT! Unplug all power cables before installing the CPU.



CAUTION!

- Upon purchase of the motherboard, ensure that the PnP cap is on the socket and the socket contacts are not bent. Contact your retailer immediately if the PnP cap is missing, or if you see any damage to the PnP cap/socket contacts/motherboard components. The manufacturer will shoulder the cost of repair only if the damage is shipment/transit-related.
 - Keep the cap after installing the motherboard. The manufacturer will process Return Merchandise Authorization (RMA) requests only if the motherboard comes with the cap on the LGA1151 socket.
 - The product warranty does not cover damage to the socket contacts resulting from incorrect CPU installation/removal, or misplacement/loss/incorrect removal of the PnP cap.
-

2.3.1 CPU installation

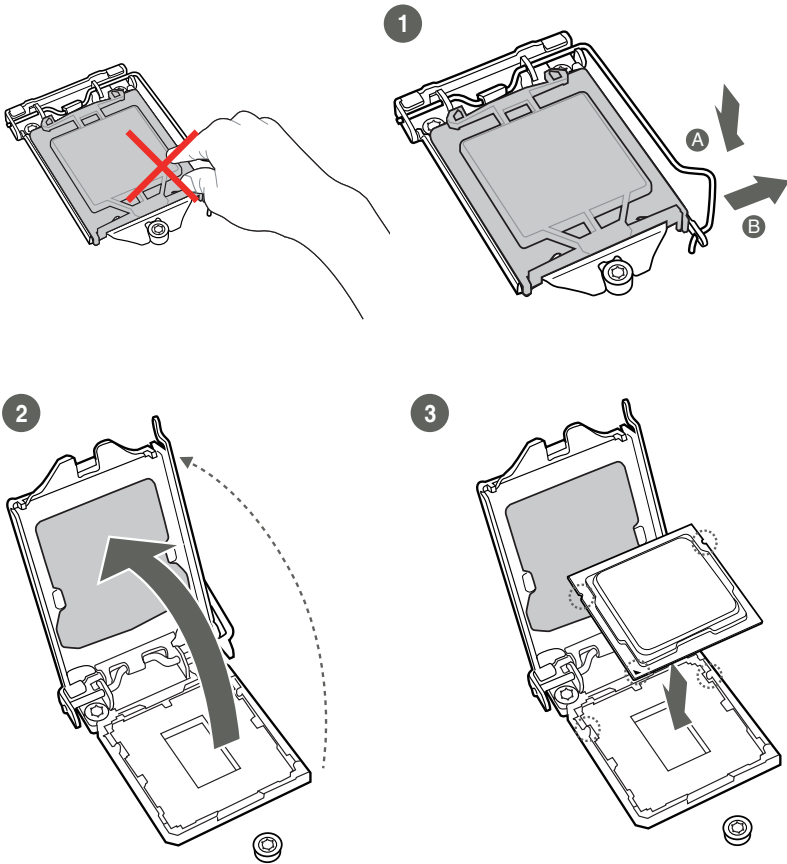

CAUTION! LGA1156 CPU is not compatible with the LGA1151 socket. DO NOT install an LGA1156 CPU on the LGA1151 socket.

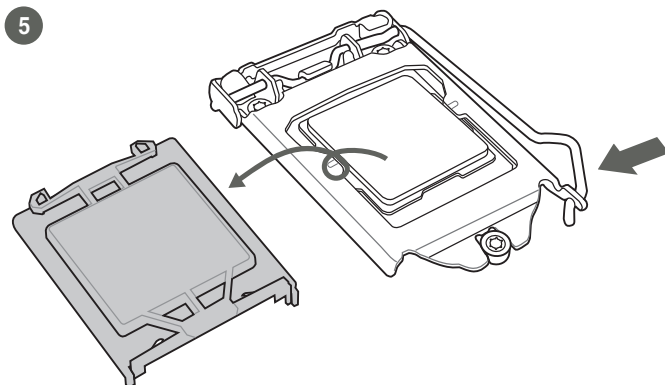
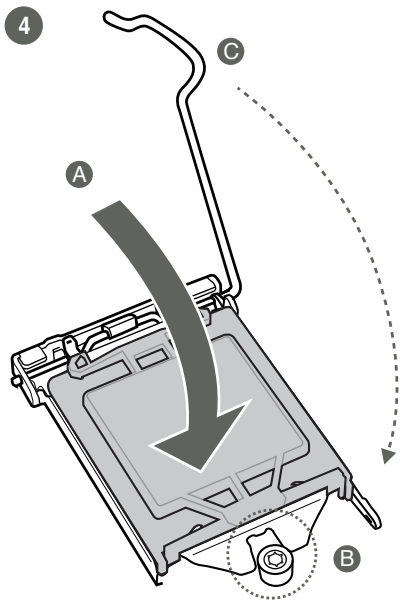

2.3.2 CPU heatsink and fan assembly installation

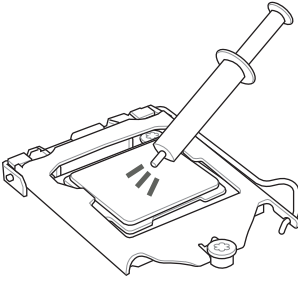

CAUTION! Apply the Thermal Interface Material to the CPU heatsink and CPU before you install the heatsink and fan if necessary.

To install the CPU heatsink and fan assembly

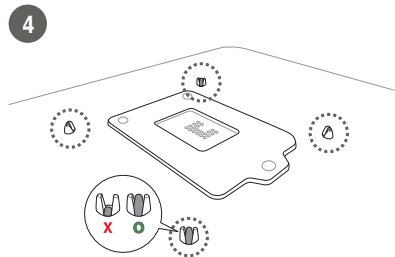
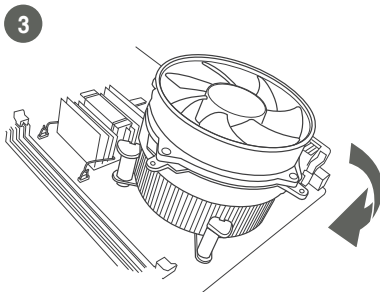
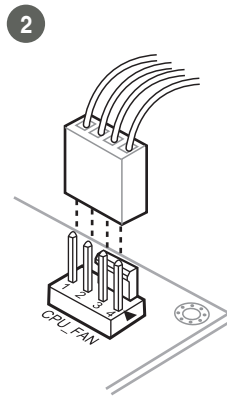
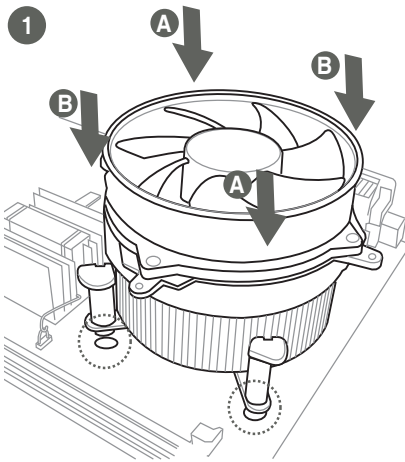

To uninstall the CPU heatsink and fan assembly

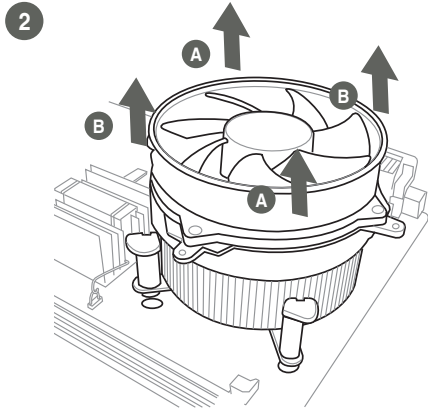
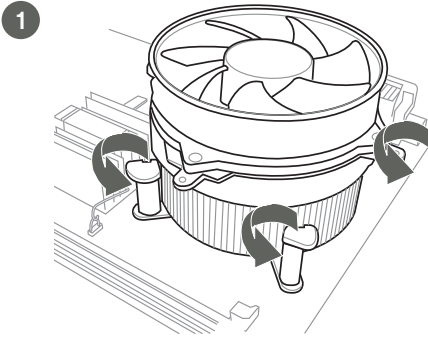

2.4 System memory

This motherboard comes with two Double Data Rate 4 (DDR4) Small Outline Dual Inline Memory Module (SO-DIMM) sockets. The figure below illustrates the location of the DDR4 SO-DIMM sockets:

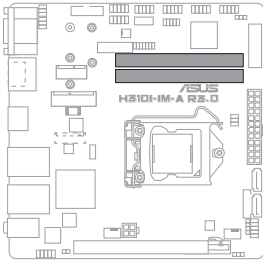

| Channel | Sockets |
|-----------|------------|
| Channel A | SO-DIMM_A1 |
| Channel B | SO-DIMM_B1 |

Recommended memory configuration

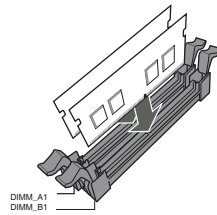
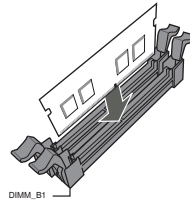
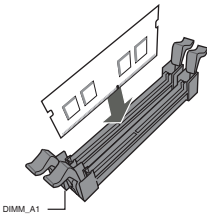

Installing a DIMM

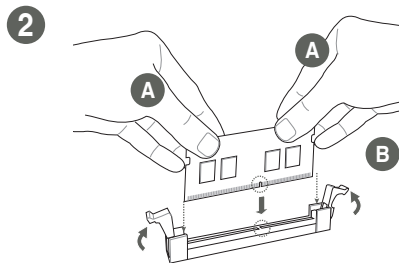
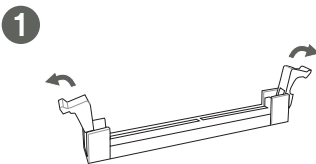

To remove a DIMM

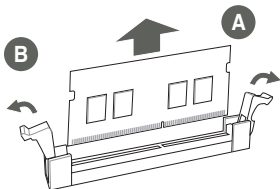

2.5 Jumpers

1. Clear RTC RAM (2-pin CLRRTC)

This header allows you to clear the CMOS RTC RAM data of the system setup information such as date, time, and system passwords.

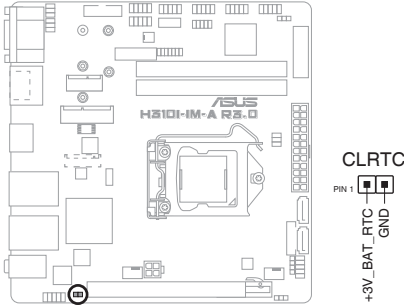

To erase the RTC RAM:

1. Turn OFF the computer and unplug the power cord.
2. Use a metal object such as a screwdriver to short the two pins.
3. Plug the power cord and turn ON the computer.
4. Hold down the key during the boot process and enter BIOS setup to re-enter data.



NOTE: If the steps above do not help, remove the onboard battery and move the jumper again to clear the CMOS RTC RAM data. After clearing the CMOS, reinstall the battery.

2. Display panel backlight power selection (3-pin BLKT_PWR_SEL)

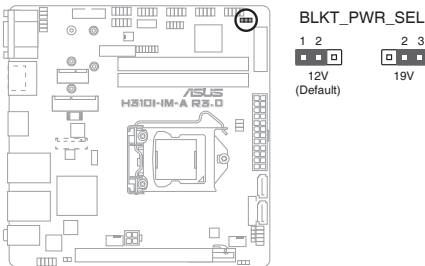

| | Pins |
|---------------|------|
| 12V (Default) | 1-2 |
| 19V | 2-3 |

3. COM1/2 Ring/+5V/+12V selection (6-pin COM1_SEL, COM2_SEL)

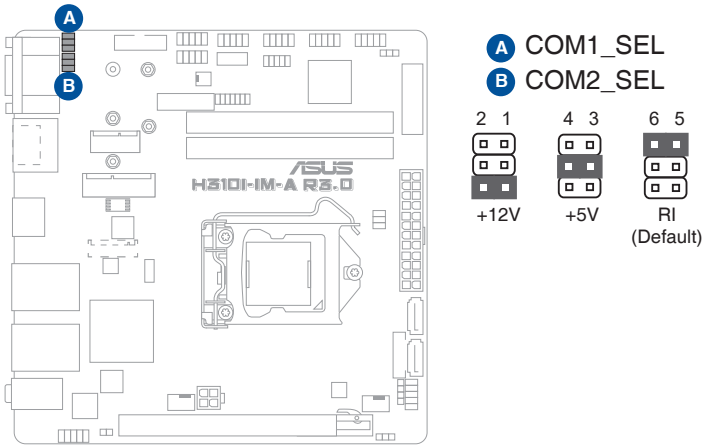

| Setting | Pins |
|----------------|------|
| +12V | 1-2 |
| +5V | 3-4 |
| Ring (Default) | 5-6 |

4. Display panel VCC power selection (6-pin VCC_PWR_SEL)

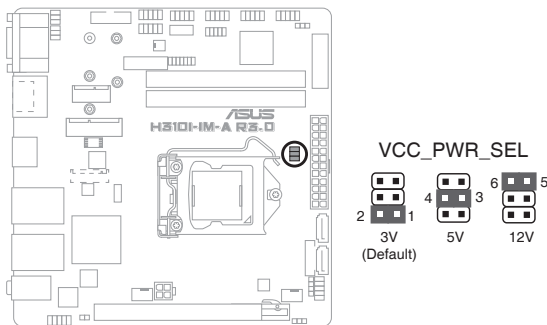

| Setting | Pins |
|--------------|------|
| 3V (Default) | 1-2 |
| 5V | 3-4 |
| 12V | 5-6 |

5. AT/ATX mode selection (3-pin AT_ATX_SEL)

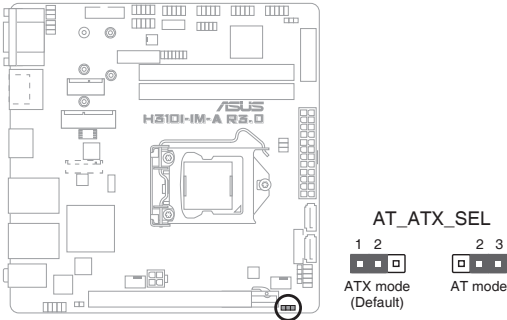

| Pins | |
|---------------|----------|
| 1-2 (Default) | ATX mode |
| 2-3 | AT mode |

2.6 Connectors

2.6.1 Rear panel connectors

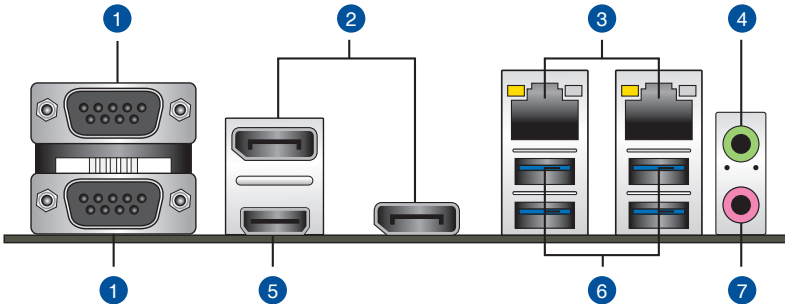

1. **Serial ports (COM).** These ports connect a modem, and other devices that conform with serial specification.
2. **DisplayPorts.** These ports are for DisplayPort-compatible devices.

3. **LAN (RJ-45) ports.** These ports allow Gigabit connection to a Local Area Network (LAN) through a network hub.

LAN port LED indications

| Activity/Link LED | | Speed LED | |
|-------------------------------|-------------------------------|-----------|--------------------|
| Status | Description | Status | Description |
| Off | No link | OFF | 10Mbps connection |
| Orange | Linked | ORANGE | 100Mbps connection |
| Orange (Blinking) | Data activity | GREEN | 1Gbps connection |
| Orange (Blinking then steady) | Ready to wake up from S5 mode | | |

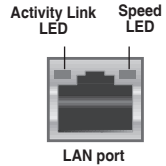

4. **Line Out port (lime).** This port connects to a headphone or a speaker. In the 4, 5.1 and 7.1-channel configurations, the function of this port becomes Front Speaker Out.
5. **HDMI® port.** This port is for a High-Definition Multimedia Interface (HDMI®) connector, and is HDCP compliant allowing playback of HD DVD, Blu-ray, and other protected content.
6. **USB 3.2 Gen 1 (up to 5Gbps) ports.** These 9-pin Universal Serial Bus (USB) ports are for USB 3.2 Gen 1 devices.



- USB 3.2 Gen 1 devices can only be used for data storage.
- We strongly recommend that you connect USB 3.2 Gen 1 devices to USB 3.2 Gen 1 ports for faster and better performance from your USB 3.2 Gen 1 devices.
- Due to the design of the Intel® 300 series chipset, all USB devices connected to the USB 2.0 and USB 3.2 Gen 1 ports are controlled by the xHCI controller. Some legacy USB devices must update their firmware for better compatibility.
- Due to chipset limitations, U31G1_E12 and U31G1_E34 ports share the same 5Gbps bandwidth.

7. Microphone port (pink). This port connects to a microphone.



Refer to the audio configuration table for the function of the audio ports in 2, 4, 5.1, or 7.1-channel configuration.

Audio 2, 4, 5.1 or 7.1-channel configuration

| Port | Headset 2-channel | 4-channel | 5.1-channel | 7.1-channel |
|-------------------------|-------------------|-------------------|------------------------------|------------------------------|
| Line Out (Rear panel) | Front Speaker Out | Front Speaker Out | Front Speaker Out | Front Speaker Out |
| MIC(Rear panel) | MIC | Rear Speaker Out | Rear Speaker Out | Rear Speaker Out |
| Headphone (Front panel) | Headphone | Headphone | Center/Subwoofer Speaker Out | Center/Subwoofer Speaker Out |
| MIC (Front panel) | MIC | MIC | MIC | Side Speaker Out |



To configure a 7.1-channel audio output:

Use a chassis with HD audio module in the front panel to support a 7.1-channel audio output.

2.6.2 Internal connectors

1. LCD panel monitor switch header (2-pin PANEL_SW)

This 2-pin header is for connecting a monitor switch that can turn off the LCD panel display backlight.

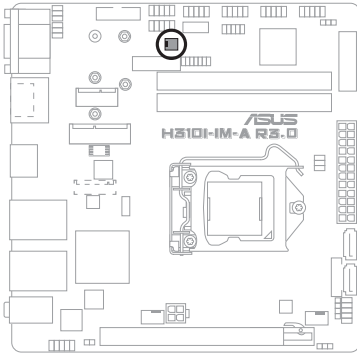

PANEL_SW

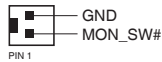

2. USB 3.2 Gen 1 connector (20-pin U32G1_12)

Connect a USB 3.2 Gen 1 module to this connector for additional USB 3.2 Gen 1 front or rear panel ports. This connector complies with USB 3.2 Gen 1 specifications and provides faster data transfer speeds of up to 5 Gbps, faster charging time for USB-chargeable devices, optimized power efficiency, and backward compatibility with USB 2.0.

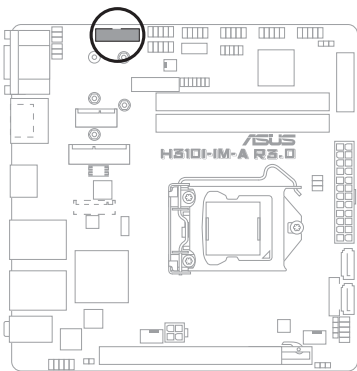

U32G1_12

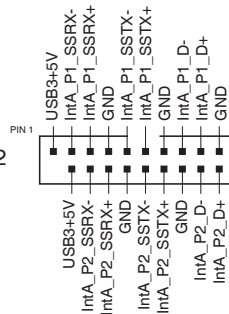

3. USB 2.0 connectors (10-pin USB56, USB78)

These connectors are for USB 2.0 ports. Connect the USB cable to these connectors. These USB connectors comply with USB 2.0 specification that supports up to 480 Mbps connection speed.

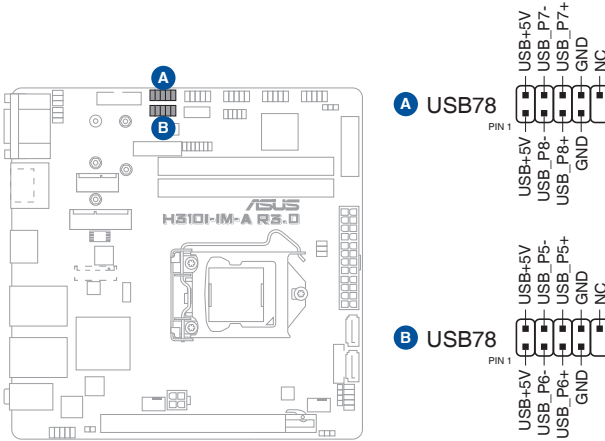

CAUTION! Never connect a 1394 cable to the USB connector. Doing so will damage the motherboard.



NOTE: The USB cable is purchased separately.

4. General purpose input/output connector (GPIO_CON)

This connector is for a general purpose input/output module which allows you to customize the digital signal input/output.

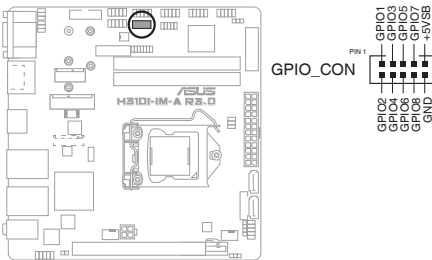

5. CPU and chassis fan connectors (4-pin CPU_FAN, 4-pin CHA_FAN)

Connect the fan cables to the fan connectors on the motherboard, ensuring that the black wire of each cable matches the ground pin of the connector.

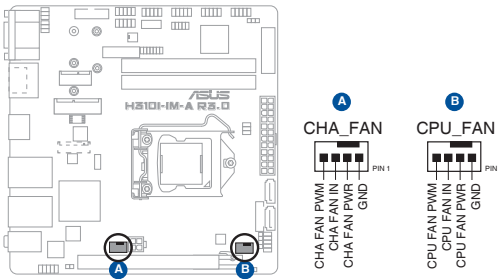

CAUTION! Do not forget to connect the fan cables to the fan connectors. Insufficient air flow inside the system may damage the motherboard components. These are not jumpers! Do not place jumper caps on the fan connectors!

6. TPM connector (14-1 pin TPM)

This connector supports a Trusted Platform Module (TPM) system, which can securely store keys, digital certificates, passwords, and data. A TPM system also helps enhance network security, protects digital identities, and ensures platform integrity.

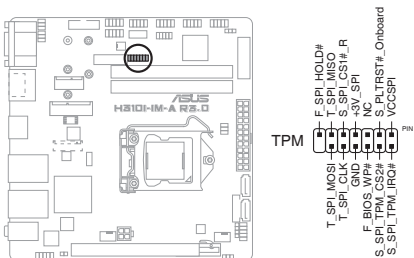

7. Front panel system panel connector (10-1 pin F_PANEL)

This connector supports several chassis-mounted functions.

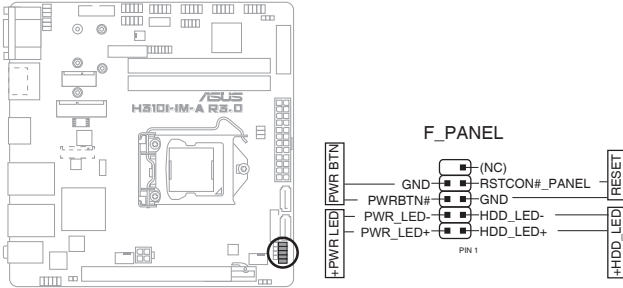

- **System power LED (2-pin +PWR_LED)**

This 2-pin connector is for the system power LED. Connect the chassis power LED cable to this connector. The system power LED lights up when you turn on the system power, and blinks when the system is in sleep mode.

- **Hard disk drive activity LED (2-pin +HDD_LED)**

This 2-pin connector is for the HDD Activity LED. Connect the HDD Activity LED cable to this connector. The IDE LED lights up or flashes when data is read from or written to the HDD.

- **ATX power button/soft-off button (2-pin PWR_BTN)**

This 2-pin connector is for the system power button.

- **Reset button (2-pin RESET)**

This 2-pin connector is for the chassis-mounted reset button for system reboot without turning off the system power.

8. Serial ATA 6.0Gb/s connectors (7-pin SATA6G_1/2)

These connectors connect to Serial ATA 6.0 Gb/s hard disk drives or optical drives via Serial ATA 6.0 Gb/s signal cables.

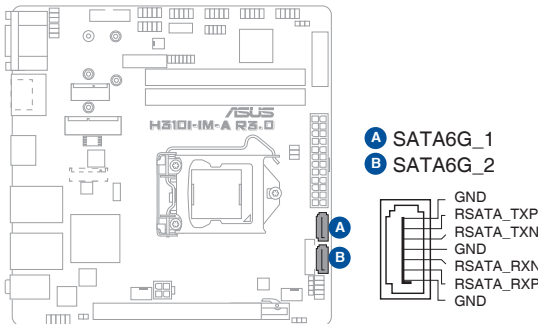

9. LVDS connector (40-pin LVDS)

This connector is for an LCD monitor that supports Low Voltage Differential Signalling (LVDS) interface.

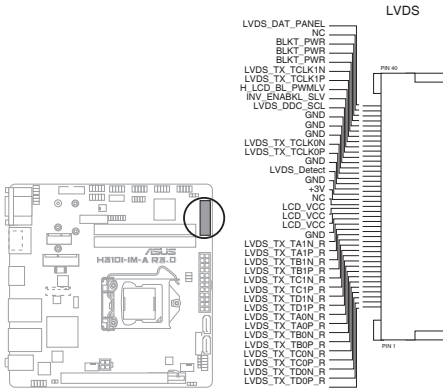

10. Speaker connector (4-pin SPEAKER)

The 4-pin connector is for the chassis-mounted system warning speaker. The speaker allows you to hear system beeps and warnings.

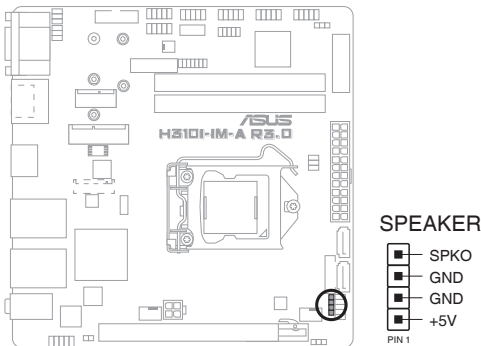

11. M.2 socket 3

This socket allows you to install an M.2 SSD module.

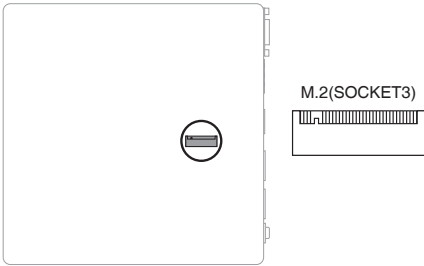

NOTES:

- The M.2 SSD module is purchased separately.
 - This slot support M Key and 2242/2260/2280 storage devices.
 - We recommend using a PH1 screwdriver with a torque of 2.0+/-0.2 kgf.cm when tightening the screw.
-

12. M.2 Wi-Fi

This socket connects to an M.2 Wi-Fi device.

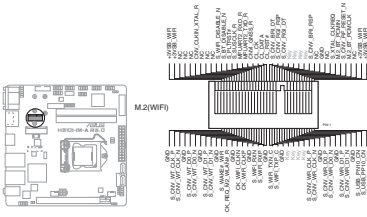

NOTES:

- The M.2 Wi-Fi module is purchased separately.
 - We recommend using a PH1 screwdriver with a torque of 2.0+/-0.2 kgf.cm when tightening the screw.
-

13. mSATA/mPCIe combo slot (MSATA_MPCIE)

This slot allows you to install a full/half length mSATA or mini-PCIe card, providing you with expandability and connectivity solutions for an optimal system performance.

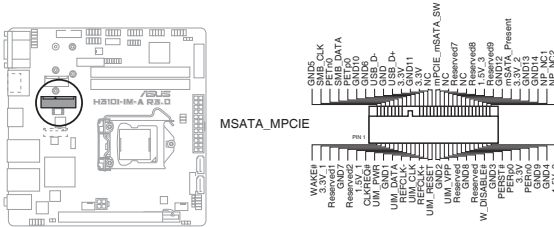

NOTE: We recommend using a PH1 screwdriver with a torque of 2.0+/-0.2 kgf·cm when tightening the screw.

14. LPC Debug header

This header allows connection to a LPC debug card.

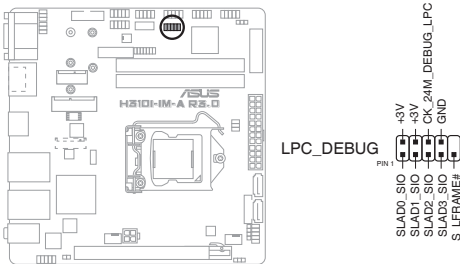

15. Serial port connectors (10-pin COM3, COM4, COM5, COM6)

These connectors are for serial (COM) modules. Connect the serial port cables to these connectors, then install the module to a slot opening at the back of the system chassis.

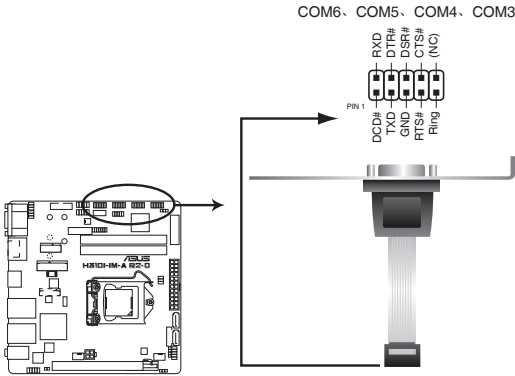

H310I-IM-A R2.0 Serial port (COM) connectors



NOTE: The serial port cables are purchased separately.

16. ATX power connectors (24-pin EATXPWR, 4-pin ATX12V)

Correctly orient the ATX power supply plugs into these connectors and push down firmly until the connectors completely fit.

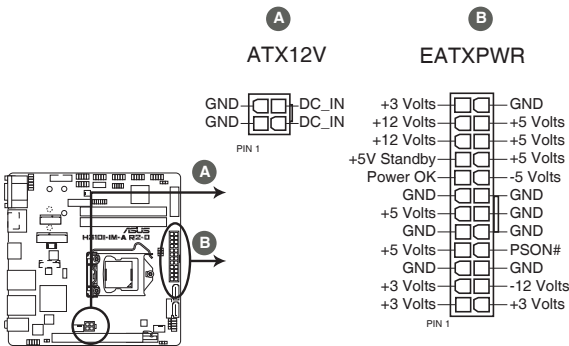

H310I-IM-A R2.0 ATX power connectors

17. Front panel audio connector (10-1 pin AAFP)

This connector is for a chassis-mounted front panel audio I/O module that supports HD Audio standard. Connect one end of the front panel audio I/O module cable to this connector.

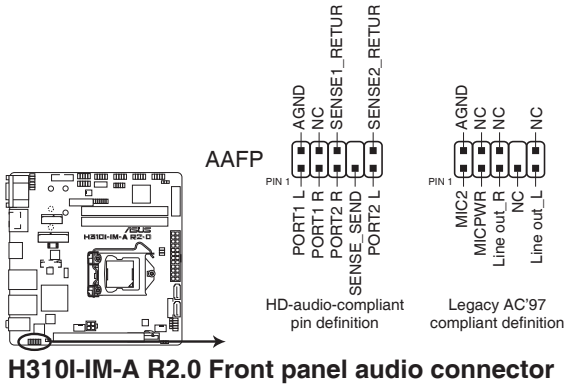

H310I-IM-A R2.0 Front panel audio connector



IMPORTANT!

- We recommend that you connect a high-definition front panel audio module to this connector to avail of the motherboard's high-definition audio capability.
- If you want to connect a high-definition front panel audio module to this connector, set the HD Audio Controller item in the BIOS setup to [Enabled].

18. Flat panel display brightness connector (8-pin LCD_BLKT_PANEL)

This connector is for the LCD panel brightness controls.

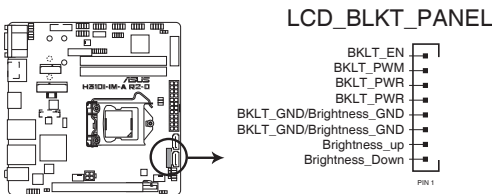

H310I-IM-A R2.0 Flat panel display brightness

2.7 Slot

1. PCI Express slot

This slot supports a PCIe x16 graphics card that complies with the PCI Express specification.

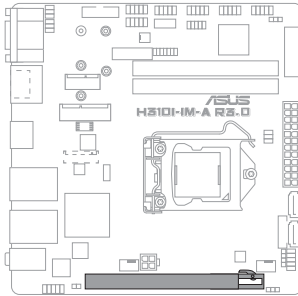

Chapter 3

BIOS setup



Scan the QR code to view the BIOS update guide.



3.1 BIOS Setup program

Use the BIOS Setup program to configure its parameters. The BIOS screens include navigation keys and brief online help to guide you in using the BIOS Setup program.

Entering BIOS Setup at startup

To enter BIOS Setup at startup:

Press <Delete> or <ECS> during the Power-On Self Test (POST). If you do not press <Delete> or <ECS>, POST continues with its routines.

Entering BIOS Setup after POST

To enter BIOS Setup after POST:

- Press <Ctrl>+<Alt>+ simultaneously.
- Press the reset button on the system chassis.
- Press the power button to turn the system off then back on. Do this option only if you failed to enter BIOS Setup using the first two options.



NOTE: Using the power button, reset button, or the <Ctrl>+<Alt>+ keys to reboot a running operating system can cause damage to your data or system. Always shut down the system properly from the operating system.



IMPORTANT!

- Visit the ASUS website at www.asus.com to download the latest BIOS file for this motherboard.
- The default BIOS settings for this motherboard apply to most working conditions and ensures optimal performance. If the system becomes unstable after changing any BIOS settings, load the default settings to regain system stability. Select the option **Restore Defaults** under the Exit menu or press hotkey <F3>.
- The BIOS Setup screens shown in this section are for reference purposes only, and may not exactly match what you see on your screen.

BIOS menu screen

The menu bar on top of the screen has the following main items:

| | |
|-------------------------|--|
| Main | For changing the basic system configuration. |
| Advanced | For changing the advanced system settings. |
| Hardware Monitor | For displaying the system temperatures, fan and power status, and changing smart fan settings. |
| Security | For configuring the system security settings. |
| Boot | For changing the system boot configuration. |
| Exit | For selecting the save options and default options. |

To select an item on the menu bar, press the right or left arrow key on the keyboard until the desired item is highlighted.

3.2 Main menu

The Main menu provides you with an overview of the basic system information, and allows you to set the system date and the system time.

3.2.1 System Date [Day MM/DD/YYYY]

Allows you to set the system date.

3.2.2 System Time [HH:MM:SS]

Allows you to set the system time.

3.3 Advanced menu

The Advanced menu items allow you to change the settings for the CPU and other system devices.



Be cautious when changing the settings of the Advanced menu items. Incorrect field values can cause the system to malfunction.

3.3.1 LVDS Configuration

Switch to LVDS

Configuration options: [Disable] [Enable]



The following item appears when you set **Switch to LVDS** to [Enable].

All-in-One Chassis

Allows you to select All-in-One (AiO) Chassis (if applicable) for simplified AiO configuration. Configuration options: [None] [1920*1080 LVDS1] [1920*1080 LVDS2] [1920*1080 LVDS3] [1600*900 LVDS4]



- Be cautious when selecting AiO chassis. Incorrect selection of AiO chassis can cause incorrect operation or potential damage to AiO chassis hardware.
- The following items appear only when you set **All-in-One Chassis** to **[None]**.

EDID Data Source

Configuration options: [Pre-Defined] [Flat Panel Display]



The following item appears when you set **EDID Data Source** to **[Pre-Defined]**.

LFP Panel Type

Allows you to select LFP panel used by Internal Graphics Device.

Configuration options: [VBIOS Default] [640x480] [800x600] [1024x768] [1280x1024] [1400x1050 LVDS1] [1400x1050 LVDS2] [1600x1200] [1366x768] [1680x1050] [1920x1200] [1440x900] [1600x900] [1024x768] [1280x800] [1920x1080] [2048x1536]

Inverter Polarity

Configuration options: [Normal] [Inverted]

Channel Select

Configuration options: [Dual Channel] [Single Channel]

Mode Select

Configuration options: [JEIDA] [VESA 6bit] [VESA 8bit] [VESA 10bit]

DIGON enable to LVDS_ON enable(T2)

Configuration options: [0] ~[50]

LVDS_ON enable to BLON enable (T3)

Configuration options: [0] ~[1023]

BLON disable to LVDS_ON disable (T4)

Configuration options: [0] ~[1023]

LVDS_ON disable to DIGON disable (T5)

Configuration options: [0] ~[50]

Completion of power down to power up (T7)

Configuration options: [0] ~[1023]

VARY_BL enable to BL_EN enable (T9)

Configuration options: [0] ~[1023]

BL_EN disable to VARY_BL disable (T10)

Configuration options: [0] ~[1023]

3.3.2 PCH-FW Configuration

This item allows you to configure Management Engine Technology parameters.

TPM Device Selection

Allows you to select TPM device.

[PTT] Enables PTT in SkuMgr.

[dTPM] Disables PTT in SkuMgr.



When PTT is disabled, all data saved on it will be lost.

3.3.3 Trusted Computing

Security Device Support

Allows you to enable or disable BIOS support for security device.

Configuration options: [Disable] [Enable]



The following items appear when a TPM device is installed on your motherboard.

SHA1 PCR Bank

Configuration options: [Disabled] [Enabled]

SHA256 PCR Bank

Configuration options: [Disabled] [Enabled]

Pending operation

Allows you to schedule an operation for security device.

Configuration options: [None] [TPM Clear]



Your computer will reboot during restart in order to change the state of security device.

Platform Hierarchy

Configuration options: [Disabled] [Enabled]

Storage Hierarchy

Configuration options: [Disabled] [Enabled]

Endorsement Hierarchy

Configuration options: [Disabled] [Enabled]

TPM 2.0 UEFI Spec Version

Configuration options: [TCG_2] [TCG_1_2]

Physical Presence Spec Version

Allows you to select to tell O.S. to support PPI Spec Version 1.2 or 1.3.

Configuration options: [1.2] [1.3]



Some HCK tests might not support 1.3.

3.3.4 CPU Configuration

The items in this menu show CPU-related information the BIOS automatically detects.

Intel (VMX) Virtualization Technology

This item, when set to [enabled], will allow a VMM to utilize the additional hardware capacities provided by Vanderpool Technology.

Configuration options: [Disabled] [Enabled]

Intel Trusted Execution Technology

Configuration options: [Disabled] [Enabled]

VT-d

Configuration options: [Disabled] [Enabled]

CPU - Power Management Control

This item allows you to manage and configure the CPU's power.

Intel® SpeedStep™

Allows your system to support more than two frequency ranges.

Configuration options: [Disabled] [Enabled]

Intel® Speed Shift Technology

Allows you to enable or disable Intel® Speed Shift Technology support.

When enabled, CPPC v2 interface allows hardware controlled P-state.

Configuration options: [Disabled] [Enabled]



The following item appears only when **Intel® SpeedStep** or **Intel® Speed Shift** is available and enabled.

Turbo Mode

Configuration options: [Disabled] [Enabled]

C states

Allows you to enable or disable CPU Power Management. Configuration

options: [Disabled] [Enabled]



The following item appears only when you set **C states** to **[Enabled]**.

Enhanced C-states

Allows you to enable or disable C1E. CPU will switch to minimum speed when all cores enter C-state. Configuration options: [Disabled] [Enabled]

3.3.5 Graphics Configuration

This item allows you to select a primary display from IGFX and PEG graphical devices.

Primary Display

Allows you to select which of the IGFX/PEG/PCI Graphics devices should be the primary display or select SG for switchable Gfx.

Configuration options: [Auto] [IGFX] [PEG]

Internal Graphics

Configuration options: [Auto] [Disabled] [Enabled]

[Auto] Keeps IGFX enabled base on the setup options.

[Disabled] Disables internal graphics.

[Enabled] Enables internal graphics.

RC6 (Render Standby)

Allows you to enable or disable render standby support.

Configuration options: [Disabled] [Enabled]

3.3.6 PCI Express Configuration

This item allows you to configure PCI Express settings.

PCIEX16 Slot

Allows you to configure the PCI Express Root Port settings.

Enable Root Port

Allows you to enable or disable the Root Port.

Configuration options: [Disabled] [Enabled]

Max Link Speed

Configuration options: [Auto] [Gen1] [Gen2] [Gen3]

Max Link Width

Configuration options: [Auto] [Force x1] [Force x2] [Force x4] [Force x8]

ASPM

Allows you to set the ASPM Level.

Configuration options: [Disabled] [Auto] [ASPM L0s] [ASPM L1] [ASPM L0sL1]

Detect Non-Compliance Device

Configuration options: [Disabled] [Enabled]

3.3.7 CSM Configuration

CSM Support

The item allows you to enable or disable CSM Support.

3.3.8 Supper IO Configuration

NCT6116D Super IO Configuration

Serial Port 1 Configuration

This item allows you to set parameters of Serial Port 1 (COMA).

Serial Port

Allows you to enable or disable the serial port (COM).
Configuration options: [Disabled] [Enabled]

COM1 Control

Allows you to select COM1 mode.
Configuration options: [RS232] [RS422] [RS485]

Serial Port 2 Configuration

This item allows you to set parameters of Serial Port 2 (COMB).

Serial Port

Allows you to enable or disable the serial port (COM).
Configuration options: [Disabled] [Enabled]

COM2 Control

Allows you to select COM2 mode.
Configuration options: [RS232] [RS422] [RS485]

Serial Port 3 Configuration

This item allows you to set parameters of Serial Port 3 (COMC).

Serial Port

Allows you to enable or disable the serial port (COM). Configuration options:
[Disabled] [Enabled]

Serial Port 4 Configuration

This item allows you to set parameters of Serial Port 4 (COMD).

Serial Port

Allows you to enable or disable the serial port (COM). Configuration options:
[Disabled] [Enabled]

Serial Port 5 Configuration

This item allows you to set parameters of Serial Port 5 (COME).

Serial Port

Allows you to enable or disable the serial port (COM). Configuration options:
[Disabled] [Enabled]

Serial Port 6 Configuration

This item allows you to set parameters of Serial Port 6 (COMF).

Serial Port

Allows you to enable or disable the serial port (COM). Configuration options:
[Disabled] [Enabled]

3.3.9 Serial Console Redirection**COM1(~6)****Console Redirection**

Allows you enable or disable the console redirection feature.

Configuration options: [Enabled] [Disabled]



The following item is accessible when you set **Console Redirection** to [Enabled].

Console Redirection Settings

The settings specify how the host computer and the remote computer (which the user is using) will exchange data. Both computers should have the same or compatible settings.

Terminal Type

Configuration options: [VT100] [VT100Plus] [VT-UTF8] [ANSI]

[VT100] ASCII char set.

[VT100Plus] Extends VT100 to support color, function keys, etc.

[VT-UTF8] Uses UTF8 encoding to map Unicode chars onto 1 or more bytes.

[ANSI] Extended ASCII char set.

Bits per second

Allows you to select serial port transmission speed. The speed must be matched on the other side. Long or noisy lines may require lower speeds.

Configuration options: [9600] [19200] [38400] [57600] [115200]

Data Bits

Configuration options: [7] [8]

Parity

A parity bit can be sent with the data bits to detect some transmission errors.

Configuration options: [None] [Even] [Odd] [Mark] [Space]

[None] Disables parity check.

[Even] Parity bit is 0 if the num of 1's in the data bits is even.

[Odd] Parity bit is 0 if the num of 1's in the data bits is odd.

[Mark] Parity bit is always 1.

[Space] Parity bit is always 0.



Mark and Space Parity do not allow for error detection.

Stop Bits

Stop bits indicate the end of a serial data packet. The standard setting is 1 stop bit. Communication with slow devices may require more than 1 stop bit.

Configuration options: [1] [2]

Flow Control

Flow control can prevent data loss from buffer overflow. When sending data, if the receiving buffers are full, a “stop” signal can be sent to stop the data flow. Once the buffers are empty, a “start” signal can be sent to re-start the flow. Hardware flow control uses two wires to send start/stop signals.

Configuration options: [None] [Hardware RTS/CTS]

VT-UTF8 Combo Key Support

Allows you to enable or disable VT-UTF8 Combination Key Support for ANSI/VT100 terminals. Configuration options: [Disabled] [Enabled]

Recorder Mode

With this mode enabled only text will be sent. This is to capture Terminal data. Configuration options: [Disabled] [Enabled]

Resolution 100x31

Allows you to enable or disable extended terminal resolution. Configuration options: [Disabled] [Enabled]

Putty KeyPad

Allows you to select FunctionKey and KeyPad on Putty.

Configuration options: [VT100] [LINUX] [XTERMR6] [SCO] [ESCN] [VT400]

3.3.10 SATA Configuration

This item allows you to configure SATA device options settings.

SATA Controller(s)

Allows you to enable or disable the onboard SATA device.

Configuration options: [Disabled] [Enabled]



The following item appears only when you set **SATA Controller(s)** to **[Enabled]**.

SATA Mode Selection

Allows you to determine how SATA controller(s) operate. Configuration options: [AHCI]

SATA6G_ 1(~2)

Port 1(~2)

Allows you to enable or disable SATA Port.

Configuration options: [Disabled] [Enabled]

Hot Plug

Allows you to designate this port as Hot Pluggable.

Configuration options: [Disabled] [Enabled]

M.2

Configuration options: [Disabled] [Enabled]

MSATA_MPCIE

Configuration options: [Disabled] [Enabled]

3.3.11 USB Configuration

Legacy USB Support

| | |
|------------|---|
| [Enabled] | Enables the support for USB devices on legacy OS. |
| [Disabled] | USB devices are only available when running BIOS Setup. |
| [Auto] | Allows the system to detect the presence of USB devices at startup. If detected, the USB controller legacy mode is enabled. If no USB device is detected, the legacy USB support is disabled. |

XHCI Hand-off

This item functions as a workaround for OSES without XHCI hand-off support. The XHCI ownership change should be claimed by XHCI driver.

Configuration options: [Enabled] [Disabled]

USB Mass Storage Driver Support

Allows you to enable or disable USB Mass Storage Driver Support.

Configuration options: [Disabled] [Enabled]

LAN1_U31G1_E1

Allows you to enable or disable USB port. Once set to [Disabled], any USB devices plugged into the connector will not be detected by BIOS or OS.

Configuration options: [Disabled] [Enabled]

LAN1_U31G1_E2

Allows you to enable or disable USB port. Once set to [Disabled], any USB devices plugged into the connector will not be detected by BIOS or OS.

Configuration options: [Disabled] [Enabled]

LAN2_U31G1_E3

Allows you to enable or disable USB port. Once set to [Disabled], any USB devices plugged into the connector will not be detected by BIOS or OS.

Configuration options: [Disabled] [Enabled]

LAN2_U31G1_E4

Allows you to enable or disable USB port. Once set to [Disabled], any USB devices plugged into the connector will not be detected by BIOS or OS.

Configuration options: [Disabled] [Enabled]

U31G1_1(~2)

Allows you to enable or disable USB port. Once set to [Disabled], any USB devices plugged into the connector will not be detected by BIOS or OS.

Configuration options: [Disabled] [Enabled]

USB_5(~8)

Allows you to enable or disable USB port. Once set to [Disabled], any USB devices plugged into the connector will not be detected by BIOS or OS.

Configuration options: [Disabled] [Enabled]

3.3.12 Onboard Devices Configuration

Audio Controller

Allows you to control detection of the HD-Audio device.

Configuration options: [Enabled] [Disabled]

[Enabled] Enables the HD Audio Device unconditionally.

[Disabled] Disables the HD Audio Device unconditionally.

Intel LAN1 Controller

[Enabled] Enables the Intel LAN controller 1.

[Disabled] Disables the controller.

Intel LAN1 PXE OPROM

This item appears only when you set the previous item to [Enabled] and allows you to enable or disable the PXE Option ROM of the Intel LAN controller 1.

Configuration options: [Disabled] [Enabled]

Intel LAN2 Controller

[Enabled] Enables the Intel LAN controller 2.

[Disabled] Disables the controller.

Intel LAN2 PXE OPROM

This item appears only when you set the previous item to [Enabled] and allows you to enable or disable the PXE Option ROM of the Intel LAN controller 2.

Configuration options: [Disabled] [Enabled]

Wi-Fi Controller

[Enabled] Enables the Wi-Fi controller.

[Disabled] Disables the controller.

Bluetooth Controller

[Enabled] Enables the Bluetooth controller.

[Disabled] Disables the controller.

M.2 Configuration

[Auto] Auto-detects the M.2 device mode.

[SATA Mode] Only supports M.2 SATA devices.

[PCIe Mode] Only supports M.2 PCIe devices.

MSATA_MPCIe Configuration

[Auto] Auto-detects the M.2 device mode.

[MSATA Mode] Only supports MSATA devices.

[MPCIe Mode] Only supports MPCIe devices.

3.3.13 NVMe Configuration

The NVMe Configuration menu displays the NVMe controller and drive information of the devices connected and allows you to configure NVMe device options settings.

3.3.14 APM Configuration

ErP Ready

Allows BIOS to switch off some power at S5 to get the system ready for ErP requirement. When set to [Enabled], all other PME options will be switched off.
Configuration options: [Enable] [Disabled]

Restore AC Power Loss

Allows you to select AC power state when power is re-applied after a power failure.
Configuration options: [S5 State] [S0 State]

Power On By PCIE

Allows you to enable or disable the Wake-on-LAN function of the onboard LAN controller or other installed PCIe LAN cards.
Configuration options: [Disabled] [Enabled]

Power On By RTC

Allows you to enable or disable the RTC (Real-Time Clock) to generate a wake event and configure the RTC alarm date. When enabled, you can set the days, hours, minutes, or seconds to schedule an RTC alarm date. Configuration options: [Disabled] [Single event] [Daily event] [Weekly event] [Monthly event]

3.3.15 EZ-Flash

This item allows you to enter EZ-Flash mode. After you press <Enter>, a confirmation message appears. Use the left/right arrow key to select between [Yes] or [No], then press <Enter> to confirm your choice.

3.3.16 Watchdog Timer

Watchdog Support

Configuration options: [Disabled] [Enabled]



The following items appear when you set **Watchdog Support** to [Enable].

Watchdog Count mode

Allows you to select Watchdog Timer I count mode.
Configuration options: [Second Mode] [Minute Mode]

Watchdog Timer

Allows you to set the Watchdog Timer I Time-out value.

3.3.17 Miscellaneous

DMI/OPI Configuration

PCI Express Configuration

DMI Link ASPM Control

Allows you to disable or control Active State Power Management on SA side of the DMI link. Configuration options: [Disabled] [L0s] [L1] [L0sL1][Auto]

3.3.18 Network Stack Configuration

Network Stack

This item allows user to disable or enable the UEFI network stack. Configuration options: [Disabled] [Enabled]



The following two items appear only when you set the previous item to [Enabled].

Ipv4 PXE Support

This item allows user to disable or enable the Ipv4 PXE Boot support. Configuration options: [Disabled] [Enabled]

Ipv6 PXE Support

This item allows user to disable or enable the Ipv6 PXE Boot support. Configuration options: [Disabled] [Enabled]

3.4 Hardware Monitor menu

The Hardware Monitor menu displays the system temperature/power status, and allows you to change the fan settings.

CPU / MotherBoard Temperature

The onboard hardware monitor automatically detects and displays the CPU / motherboard temperatures.

CPU / Chassis Fan Speed

The onboard hardware monitor automatically detects and displays the CPU / chassis fan speeds in rotations per minute (RPM). If the fan is not connected to the motherboard, the field shows N/A. Select Ignore if you do not wish to display the detected speed.

CPU Core Voltage, 3.3V Voltage, 5V Voltage, 12V Voltage

The onboard hardware monitor automatically detects the voltage output through the onboard voltage regulators. Select Ignore if you do not want to detect this item.

Smart Fan Mode

Allows you to select the Smart Fan mode. Configuration options: [Disabled] [Normal] [Manual Mode]



The following items appear when you set **Smart Fan Mode** to [Manual Mode].

Chassis Fan Setting

Temperature 1(~4)

Allows you to set the value of temperature1(~4).

FD/RPM 1(~4)

Allows you to set the value of Fan Duty/PRM 1(~4) when temperature is T1(~4).

CPU Fan Setting

Temperature 1(~4)

Allows you to set the value of temperature1(~4).

FD/RPM 1(~4)

Allows you to set the value of Fan Duty/PRM 1(~4) when temperature is T1(~4).

3.5 Security menu

The Security menu allows a new password to be created or a current password to be changed. The menu also enables or disables the Secure Boot state and lets the user configure the System Mode state.

3.5.1 Administrator Password

If you have set an administrator password, we recommend that you enter the administrator password for accessing the system.

To set an administrator password:

1. Select the **Administrator Password** item and press <Enter>.
2. From the **Create New Password** box, key in a password, then press <Enter>.

To change an administrator password:

1. Select the **Administrator Password** item and press <Enter>.
2. From the **Enter Current Password** box, key in the current password, then press <Enter>.
3. From the **Create New Password box**, key in a new password, then press <Enter>.
4. Confirm the password when prompted.



To clear the administrator password, follow the same steps as in changing an administrator password, but press <Enter> when prompted to create/confirm the password.

3.5.2 User Password

If you have set a user password, you must enter the user password for accessing the system.

To set a user password:

1. Select the **User Password** item and press <Enter>.
2. From the **Create New Password** box, key in a password, then press <Enter>.
3. Confirm the password when prompted.

To change a user password:

1. Select the **User Password** item and press <Enter>.
2. From the **Enter Current Password** box, key in the current password, then press <Enter>.
3. From the **Create New Password** box, key in a new password, then press <Enter>.
4. Confirm the password when prompted.

3.5.3 Secure Boot

Secure Boot feature is active when Secure Boot is set to [Enabled], Platform Key (PK) is enrolled and the system is running in User mode. Changing the mode requires platform reset. Configuration options: [Disabled] [Enabled]

Secure Boot Mode

Allows you to select Secure Boot Mode. When set to [Custom], Secure Boot Policy variables can be configured by a physically present user without full authentication. Configuration options: [Standard] [Custom]

Key Management

Allows you to modify Secure Boot Policy variables without full authentication.

Platform Key (PK)

Configuration options: [Update]

Key Exchange Keys / Authorized Signatures

Configuration options: [Update] [Append]

Forbidden Signatures

Configuration options: [Details] [Export][Update] [Append] [Delete]

3.6 Boot menu

The Boot menu items allow you to change the system boot options.

Boot Configuration

Setup Prompt Timeout

Allows you to set the number of seconds to wait for setup activation key. 65535(0xFFFF) means indefinite waiting.

Bootup NumLock State

Allows you to select the keyboard NumLock state. Configuration options: [On] [Off]

Quiet Boot

Configuration options: [Disabled] [Enabled]

Fast Boot

Allows you to enable or disable boot with initialization of a minimal set of devices required to launch active boot option. This has no effect for BBS boot options. Configuration options: [Disabled] [Enabled]

Boot mode select

Configuration options: [UEFI] [LEGACY]

FIXED BOOT ORDER Priorities

Boot Option #1(~5)

Allows you to set the system boot order. Configuration options: [Hard Disk] [NVME] [CD/DVD] [USB Device] [Network] [Disabled]

3.7 Exit menu

The Exit menu items allow you to load the optimal default values for the BIOS items, and save or discard your changes to the BIOS items. You can access the EZ Mode from the Exit menu.

Save Changes and Exit

Allows you to exit the system setup program after saving the changes.

Discard Changes and Exit

Allows you to exit the system setup program without saving the changes you made. When you select this option or if you press <Esc>, a confirmation window appears. Select **Yes** to discard changes and exit.

Save Changes and Reset

Allows you to reset the system setup after saving the changes.
from one of the available filesystem devices.

Discard Changes and Reset

Allows you to reset the system setup without saving the changes you made.

Save Options

Save Changes

Allows you to save changes done so far to any of the setup options.

Discard Changes

Allows you to discard changes done so far to any of the setup options.

Restore Defaults

Allows you to restore or load default values for all the setup options.

Save as User Defaults

Allows you to save the changes done so far as User Defaults.

Restore User Defaults

Allows you to restore the User Defaults to all the setup options.

Appendix

Notices

FCC Compliance Information

Responsible Party: Asus Computer International

Address: 48720 Kato Rd., Fremont, CA 94538, USA

Phone / Fax No: (510)739-3777 / (510)608-4555

This device complies with part 15 of the FCC Rules. Operation is subject to the following two conditions: (1) This device may not cause harmful interference, and (2) this device must accept any interference received, including interference that may cause undesired operation.

This equipment has been tested and found to comply with the limits for a Class B digital device, pursuant to part 15 of the FCC Rules. These limits are designed to provide reasonable protection against harmful interference in a residential installation. This equipment generates, uses and can radiate radio frequency energy and, if not installed and used in accordance with the instructions, may cause harmful interference to radio communications. However, there is no guarantee that interference will not occur in a particular installation. If this equipment does cause harmful interference to radio or television reception, which can be determined by turning the equipment off and on, the user is encouraged to try to correct the interference by one or more of the following measures:

- Reorient or relocate the receiving antenna.
- Increase the separation between the equipment and receiver.
- Connect the equipment into an outlet on a circuit different from that to which the receiver is connected.
- Consult the dealer or an experienced radio/TV technician for help.

Compliance Statement of Innovation, Science and Economic Development Canada (ISED)

This device complies with Innovation, Science and Economic Development Canada licence exempt RSS standard(s). Operation is subject to the following two conditions: (1) this device may not cause interference, and (2) this device must accept any interference, including interference that may cause undesired operation of the device.

CAN ICES-003(B)/NMB-003(B)

Déclaration de conformité de Innovation, Sciences et Développement économique Canada (ISED)

Le présent appareil est conforme aux CNR d'Innovation, Sciences et Développement économique Canada applicables aux appareils radio exempts de licence. L'exploitation est autorisée aux deux conditions suivantes : (1) l'appareil ne doit pas produire de brouillage, et (2) l'utilisateur de l'appareil doit accepter tout brouillage radioélectrique subi, même si le brouillage est susceptible d'en compromettre le fonctionnement.

CAN ICES-003(B)/NMB-003(B)

VCCI: Japan Compliance Statement

Class B ITE

この装置は、クラスB情報技術装置です。この装置は、家庭環境で使用することを目的としています。この装置がラジオやテレビジョン受信機に近接して使用されると、受信障害を引き起こすことがあります。

取扱説明書に従って正しい取り扱いをして下さい。

VCCI-B

KC: Korea Warning Statement

B급 기기 (가정용 방송통신기자재)

이 기기는 가정용(B급) 전자파적합기기로서 주로 가정에서 사용하는 것을 목적으로 하며, 모든 지역에서 사용할 수 있습니다.

HDMI Compliance Statement

The terms HDMI, HDMI High-Definition Multimedia Interface, and the HDMI Logo are trademarks or registered trademarks of HDMI Licensing Administrator, Inc.

Google™ License Terms

Copyright© 2022 Google Inc. All Rights Reserved.

Licensed under the Apache License, Version 2.0 (the “License”); you may not use this file except in compliance with the License. You may obtain a copy of the License at:

<http://www.apache.org/licenses/LICENSE-2.0>

Unless required by applicable law or agreed to in writing, software distributed under the License is distributed on an “AS IS” BASIS, WITHOUT WARRANTIES OR CONDITIONS OF ANY KIND, either express or implied.

See the License for the specific language governing permissions and limitations under the License.

Declaration of compliance for product environmental regulation

ASUS follows the green design concept to design and manufacture our products, and makes sure that each stage of the product life cycle of ASUS product is in line with global environmental regulations. In addition, ASUS disclose the relevant information based on regulation requirements.

Please refer to <http://csr.asus.com/Compliance.htm> for information disclosure based on regulation requirements ASUS is complied with:

EU REACH and Article 33

Complying with the REACH (Registration, Evaluation, Authorisation, and Restriction of Chemicals) regulatory framework, we published the chemical substances in our products at ASUS REACH website at <http://csr.asus.com/english/REACH.htm>.

EU RoHS

This product complies with the EU RoHS Directive. For more details, see <http://csr.asus.com/english/article.aspx?id=35>

India RoHS

This product complies with the “India E-Waste (Management) Rules, 2016” and prohibits use of lead, mercury, hexavalent chromium, polybrominated biphenyls (PBBs) and polybrominated diphenyl ethers (PBDEs) in concentrations exceeding 0.1% by weight in homogenous materials and 0.01% by weight in homogenous materials for cadmium, except for the exemptions listed in Schedule II of the Rule.

Vietnam RoHS

ASUS products sold in Vietnam, on or after September 23, 2011, meet the requirements of the Vietnam Circular 30/2011/TT-BCT.

Các sản phẩm ASUS bán tại Việt Nam, vào ngày 23 tháng 9 năm 2011 trở về sau, đều phải đáp ứng các yêu cầu của Thông tư 30/2011/TT-BCT của Việt Nam.

Türkiye RoHS

AEEE Yönetmeliğine Uygundur

ASUS Recycling/Takeback Services

ASUS recycling and takeback programs come from our commitment to the highest standards for protecting our environment. We believe in providing solutions for you to be able to responsibly recycle our products, batteries, other components as well as the packaging materials. Please go to <http://csr.asus.com/english/Takeback.htm> for detailed recycling information in different regions.



DO NOT throw the motherboard in municipal waste. This product has been designed to enable proper reuse of parts and recycling. This symbol of the crossed out wheeled bin indicates that the product (electrical and electronic equipment) should not be placed in municipal waste. Check local regulations for disposal of electronic products.



DO NOT throw the mercury-containing button cell battery in municipal waste. This symbol of the crossed out wheeled bin indicates that the battery should not be placed in municipal waste.

Service and Support

Visit our multi-language website at <https://www.asus.com/support/>



| | |
|--|---|
| Manufacturer | ASUSTek COMPUTER INC. |
| Address, City | 1F, No. 15, Lide Rd., Beitou Dist., Taipei City 112, Taiwan |
| Authorized Representative in Europe | ASUS COMPUTER GmbH |
| Address | Harkortstrasse 21-23, 40880 Ratingen |
| Country | Germany |
| Authorized Representative in United Kingdom | ASUSTEK (UK) LIMITED |
| Address | 1st Floor, Sackville House, 143-149 Fenchurch Street, London, EC3M 6BL, England |
| Country | United Kingdom |