



FortiADC 2200F

QuickStart Guide

Product Registration

Thank you for purchasing a Fortinet FortiADC. To access:

- Cloud Management
- FortiGuard Updates
- Firmware Upgrades
- Technical Support
- Warranty Coverage

Please register your Fortinet FortiADC:

Vous devez enregistrer le produit:

Debe registrar el producto:

登録のお願い:

请马上注册:

<http://support.fortinet.com>



This guide covers: FAD-2200F, FAD-2200F-DC

November 19, 2024

Copyright © 2024 Fortinet, Inc. All rights reserved. Fortinet®, FortiGate®, FortiCare® and FortiGuard®, and certain other marks are registered trademarks of Fortinet, Inc., and other Fortinet names herein may also be registered and/or common law trademarks of Fortinet. All other product or company names may be trademarks of their respective owners. Performance and other metrics contained herein were attained in internal lab tests under ideal conditions, and actual performance and other results may vary. Network variables, different network environments and other conditions may affect performance results. Nothing herein represents any binding commitment by Fortinet, and Fortinet disclaims all warranties, whether express or implied, except to the extent Fortinet enters a binding written contract, signed by Fortinet's SVP Legal and above, with a purchaser that expressly warrants that the identified product will perform according to certain expressly-identified performance metrics and, in such event, only the specific performance metrics expressly identified in such binding written contract shall be binding on Fortinet. For absolute clarity, any such warranty will be limited to performance in the same ideal conditions as in Fortinet's internal lab tests. Fortinet disclaims in full any covenants, representations, and guarantees pursuant hereto, whether express or implied. Fortinet reserves the right to change, modify, transfer, or otherwise revise this publication without notice, and the most current version of the publication shall be applicable.

For Product License Agreement / EULA and Warranty Terms, visit <https://www.fortinet.com/content/dam/fortinet/assets/legal/EULA.pdf>

Contents - FAD 2200F

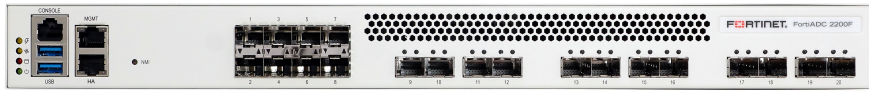

FortiADC 2200F



QuickStart Guide



2x Power Cables
(AC models only)



1x Console Cable
(USB to RJ45)



1x Ethernet Cable



2x DC Connectors
(DC Models only)

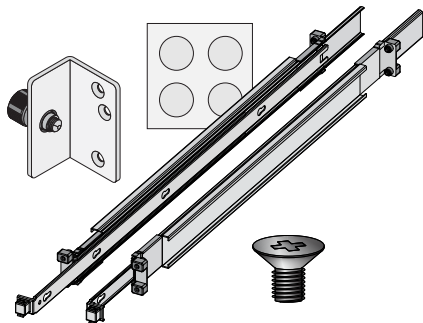

1x Accessory Kit
(2x Rails, 2x Rail Screws,
4x Rubber Feet, 2x Rackmount Ears)

Optional SFP Transceiver Modules

FN-TRAN-SFP+SR, 10 GE SFP+ transceiver module, short range with SFP+ and SFP/SFP+ slots

FN-TRAN-SFP+LR, 10 GE SFP+ transceiver module, long range with SFP+ and SFP/SFP+ slots

Front Panel - FAD 2200F

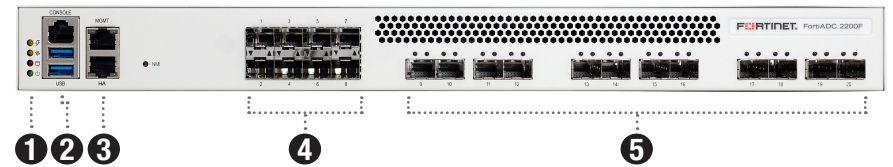

- 1 System LED Indicators**

Power Supply Alarm Amber: Power supply failure Off: Normal operation	Power Supply Fan Alarm Amber: Fan failure Off: Normal operation
Hard Disk Alarm Flashing Red: Data activity Off: Normal operation	System Power Indicator Green: Power on Off: Power off
- 2 CONSOLE (RJ45) port** for serial port management
 USB (USB A x2) USB 3.0 server port
- 3 Management Port (RJ45)** GE device management, default IP is 192.168.1.99
 HA (RJ45) GE high availability port
- 4 Ports 1 to 8 (SFP)** GE SFP slots
 - Green:** Link established at 1 Gbps
 - Flashing Green:** Transmitting data at 1 Gbps
 - Amber:** Link established at 100 Mbps
 - Flashing Amber:** Transmitting data at 100 Mbps
 - Off:** No link established
- 5 Ports 9 to 20 (SFP+)** 10 GE SFP+ slots
 - Green:** Link established at 10Gbps
 - Flashing Green:** Transmitting data
 - Off:** No link established

Rear Panel - FAD 2200F

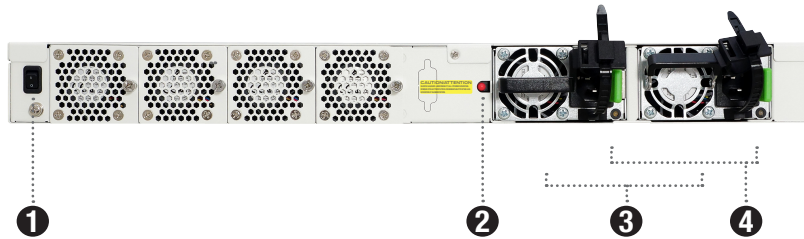

- 1 Power Switch** turns the power ON/OFF
- 2 Power Alarm Button** resets a power supply error
- 3 Redundant Power Supplies (x2)** 100 to 240V AC, 7-3.5A, 50/60Hz
- 4 Power Supply Indicator**
 - **Green:** Power supply operating normally
 - ⊗ **Flashing Green (1 sec):** AC input but in Active-Standby mode
 - **Amber:** AC input power failure; second power supply operating normally
 - **Off:** No AC input

Rear Panel - FAD 2200F-DC

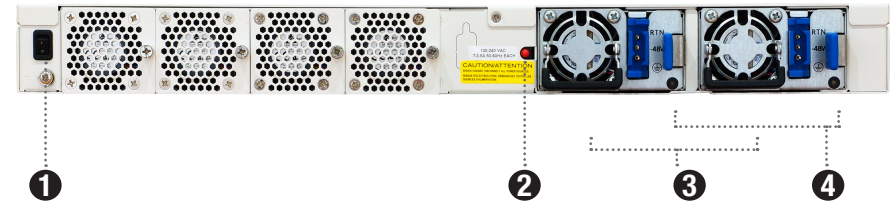

- 1 Power Switch** turns the power ON/OFF
- 2 Power Alarm Button** resets a power supply error
- 3 Redundant Power Supplies (x2)** -48V DC to -60V DC, 20A
- 4 DC Power Supply Indicator**
 - **Green:** PSU operating normally
 - ⊗ **Flashing Green (1 sec):** DC power present but in Active-Standby mode
 - **Amber:** DC input power failure; second power supply operating normally
 - ⊗ **Flashing Amber:** PSU warning event
 - **Off:** No DC input

AC Installation

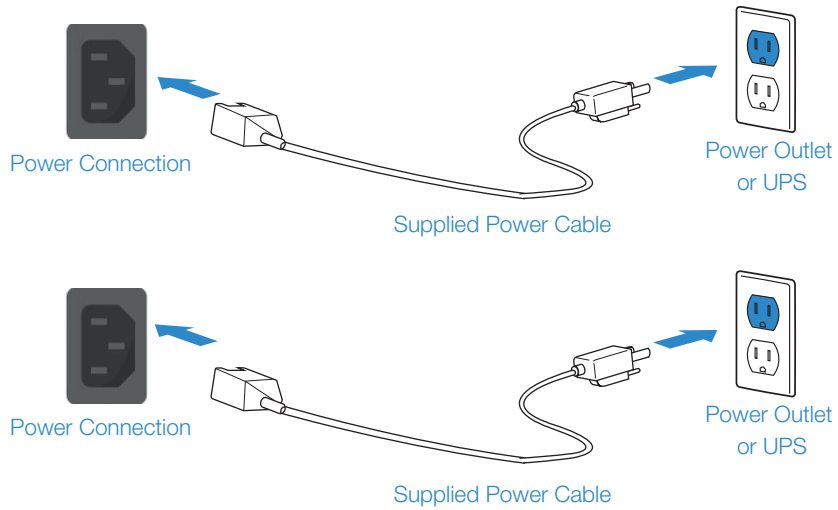

Plug in your device to a power outlet using the provided power cables.

Note: We recommend connecting your FortiADC to an [uninterruptible power supply \(UPS\)](#) in case of a power outage

DC Cable Installation

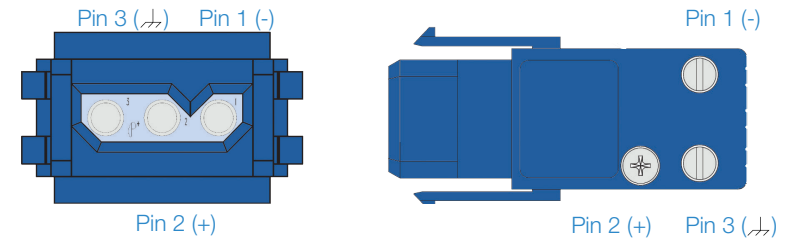

Assemble the power cables using the [supplied power connector](#).

Note: Pin 1 is Negative. Pin 2 is Positive. Pin 3 is Ground. Cables and terminal lugs are not included. The wires are rated at least 14 AWG.

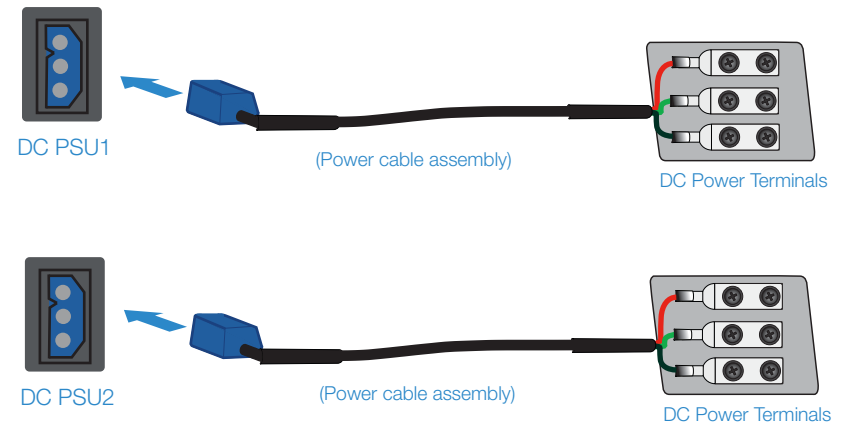

Plug in your device to a power outlet using the provided DC power cables.

Note: We recommend connecting your FortiADC to an [uninterruptible power supply \(UPS\)](#) in case of a power outage

Rack Installation

The supplied equipment is designed for standard 19inch racks. The rails provided are specially designed for this model.

Rack Stability

Ensure the rack is stable before installing the slide rails and appliance.

- Check that the leveling jacks on the bottom of the rack are fully extended to the floor with the full weight of the rack resting on the jacks
- For single rack installation, stabilizers should be attached to the rack; for multiple rack installations, the racks should be coupled together

Appliance Installation

- To avoid personal injury or equipment damage, use a lifting device
- Do not pick up the appliance by the front handles
- Each inner rail has a system lock out tab to prevent the appliance from sliding out, ensure that it is locked when installing the appliance
- Prevent Electrostatic discharge (ESD) damage by wearing antistatic devices
- Do not place heavy objects on the appliance

What You Will Need

- Philips screwdriver, level & tape measure
- Rack-provided cage nuts and screws
- A lifting device or additional support
- ESD antistatic gear

Support

For video support on installing these slide rails, please visit:

<https://video.fortinet.com>

For additional support, please visit:

<http://support.fortinet.com>

Rail Assembly

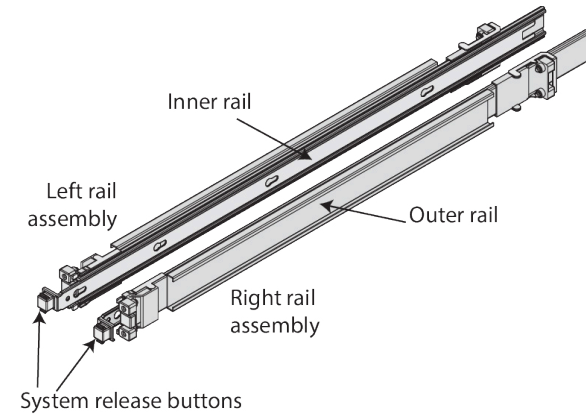

- The rail kit includes a left and a right rail assembly
- Each rail assembly includes an inner rail, a middle rail, and an outer rail
- The inner rail has locking keyholes used to secure the rail to the appliance
- The inner rail rear end has a lock out tab which slides into the middle rail
- The middle rail is in the outer rail and used to guide the inner rail into the outer rail
- The outer rail has front and rear mounting pins that push into to the rack holes
- The outer rail also has front and rear locking latches to secure the rail to the rack

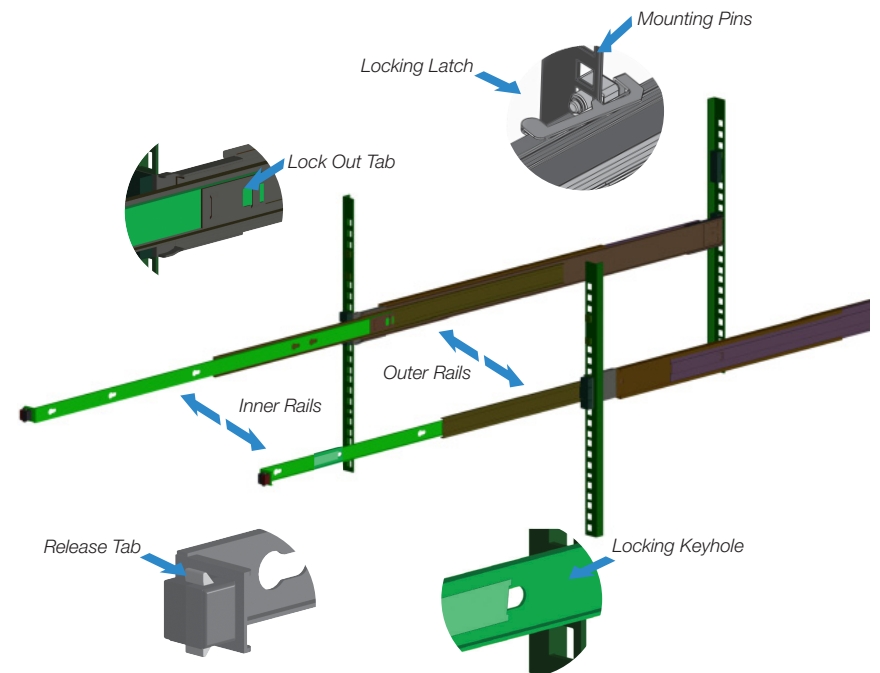

Attach the Inner Rails to the Appliance

1. Detach the inner rail from the rail assembly by pressing the lock out tab
2. Place an inner rail against a side of the appliance
3. Align the inner rail keyholes with the appliance pins
4. Slide the rail towards the front of the appliance until the metal clip locks into place
5. For inner rails with 5 keyholes and a chassis with 3 pins and a thread hole, use the provided M4 shoulder screw to secure the rail to the appliance
6. Repeat steps 1 to 5 for the remaining inner rail

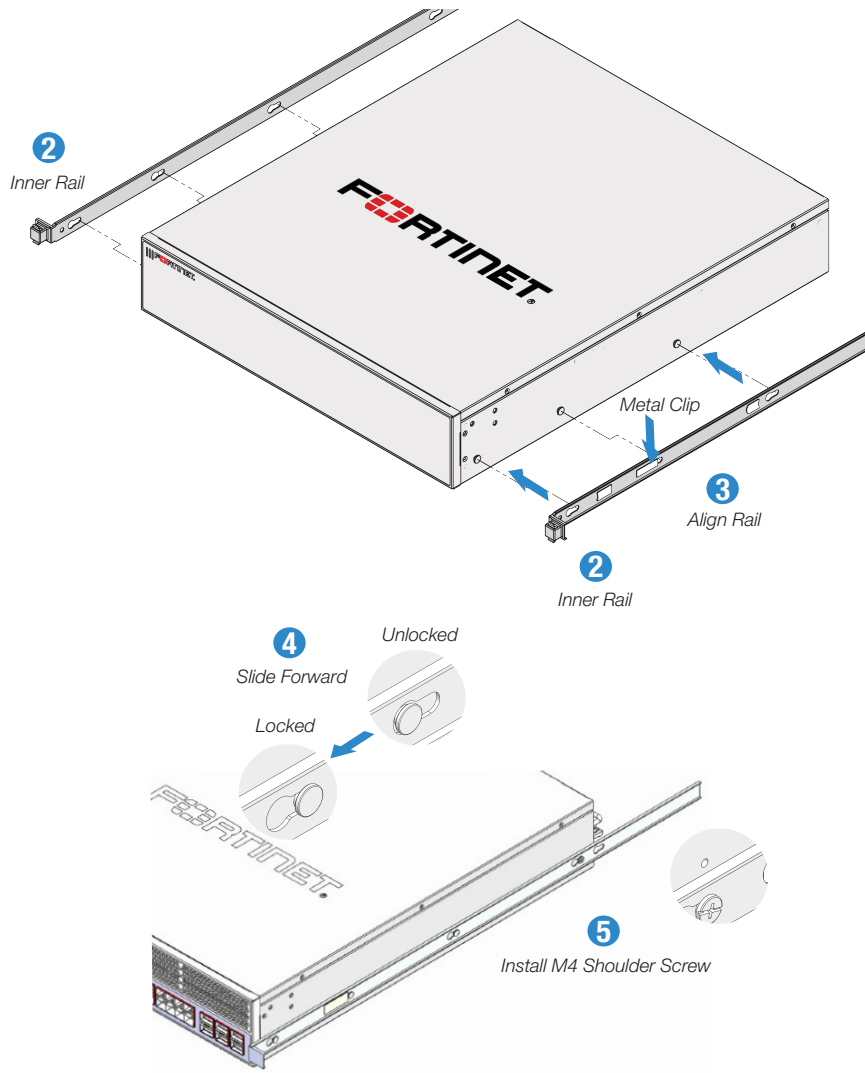

Attach the Outer Rails to the Rack

Front Outer Rail

1. Place an outer rail against a side of the rack
2. Align the front outer rail with the front of the rack
3. Push the front outer rail mounting pins into the rack post holes
4. Lock the locking latch to safely secure the front outer rail to the post

Rear Outer Rail

5. Extend the rear outer rail just past the rack post
6. Level the rail and align the mounting pins
7. Push the rear mounting pins into the rack post holes
8. Lock the locking latch to safely secure the rear outer rail to the post
9. Repeat steps 1 to 8 for the remaining outer rail

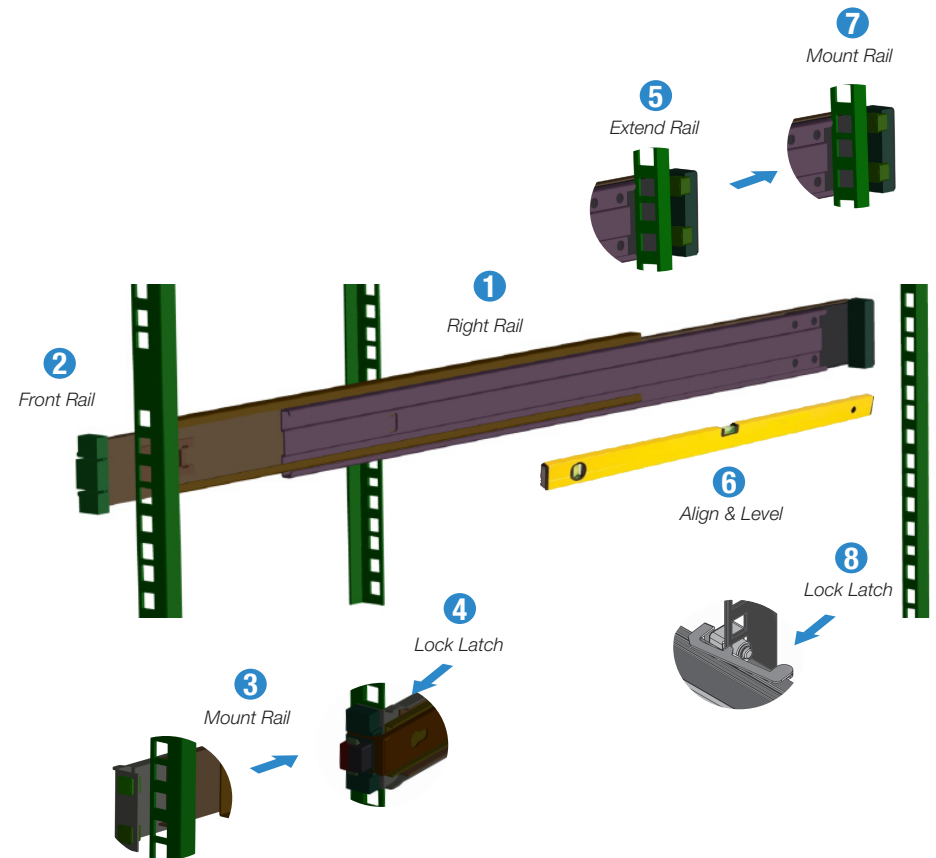

Install the Appliance

Safety Precautions

1. Check that the inner rails are secured to the appliance
2. Inspect that the rack posts and outer rails are secured and level

Rail Installation

3. Slide the middle outer rails forward until they fully extend and lock into place
4. Using a lifting device, lift the appliance and align the inner rails with the middle rails
5. Slide the appliance and inner rails into the middle rails until there is a stop

System Lock

6. Apply even pressure and slide the release tabs outward while sliding the appliance all the way into the rack until the system release tabs click and lock into position
7. Use four rack screws (not provided) to secure the appliance to the rack

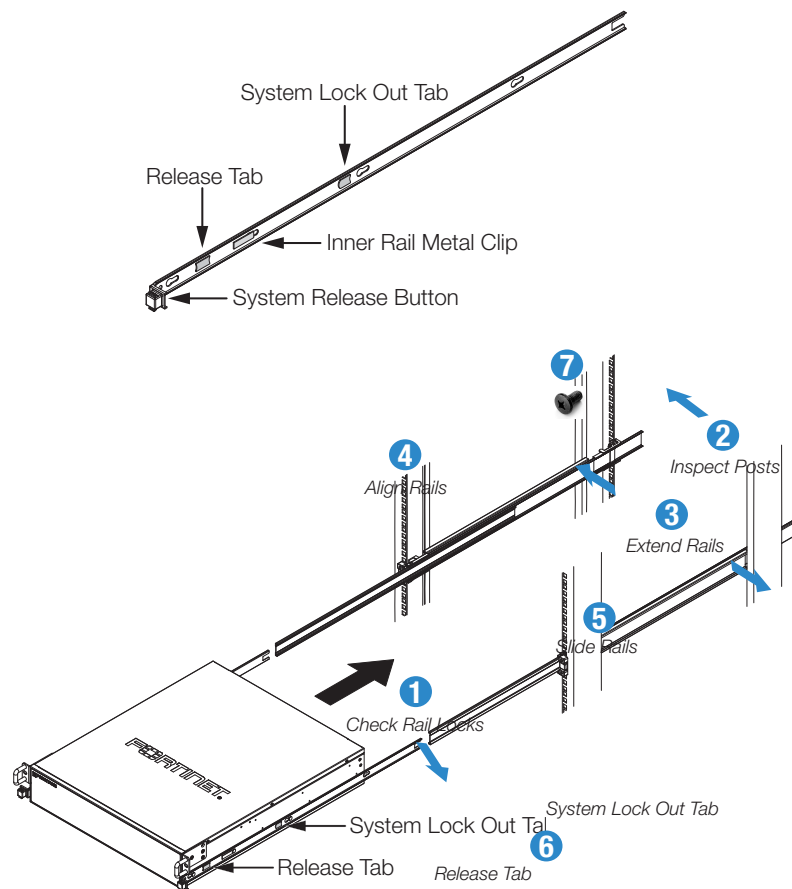

Deployment

Fully integrate with Fortinet's Security Fabric to optimize network visibility, load balancing, and user authentication with your new FortiADC.

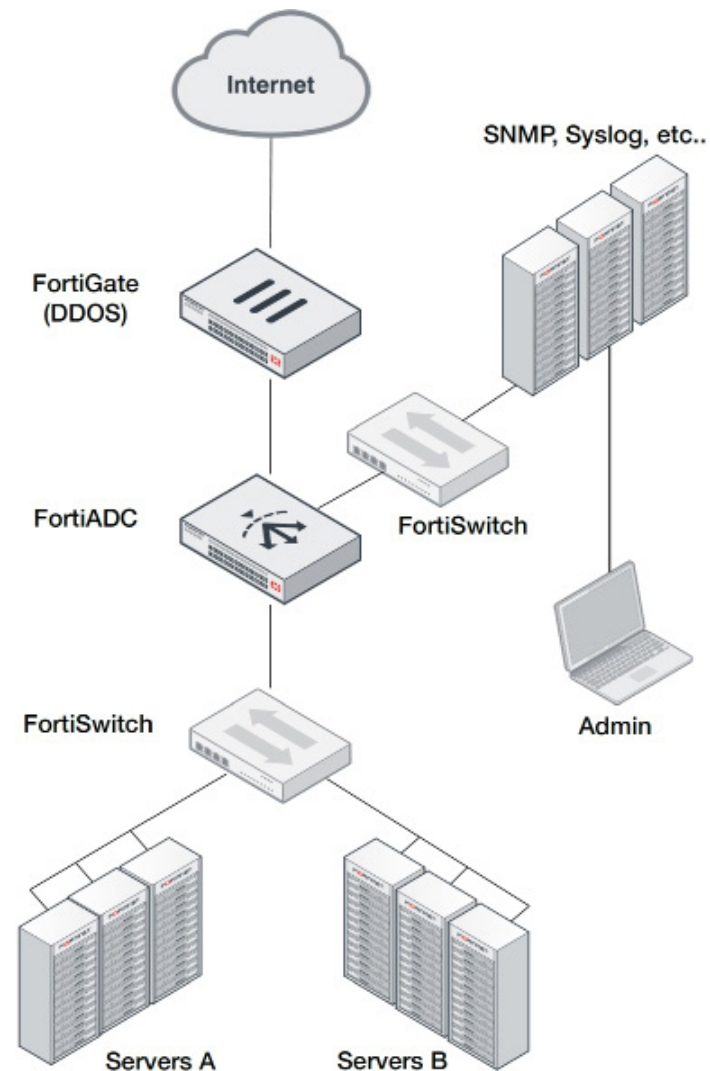

Setup Options

Set up your device locally using the GUI or CLI. Choose an option to complete your setup, then configure your device.



Local Setup

A GUI

An [easy-to-use GUI](#), compatible with most web browsers. To minimize scrolling, the screen resolution should be at least 1280 x 1024 pixels.



Local Setup

B Command Line Interface (CLI)

An alternate configuration tool from the web-based manager that uses a [terminal emulation](#) application to [type commands](#) or upload batches of commands from a text file or [configuration script](#).

A GUI

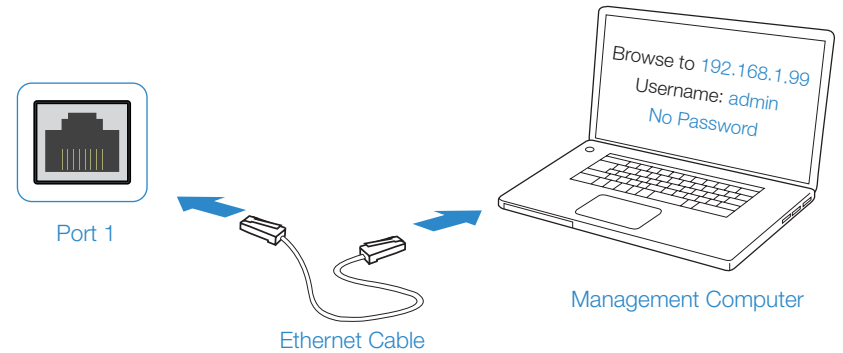

1. Connect [Port 1](#) to the [Management Computer](#) using the supplied [Ethernet cable](#)
2. Enable [DHCP](#) or set the Management Computer's [IP](#) and [subnet](#) to:

Static IP Address: [192.168.1.1](#)
Subnet Mask: [255.255.255.0](#)

3. Visit [192.168.1.99](#) in a web browser
4. Log in with username [admin](#) and [no password](#)
5. You can now configure your FortiADC

B CLI

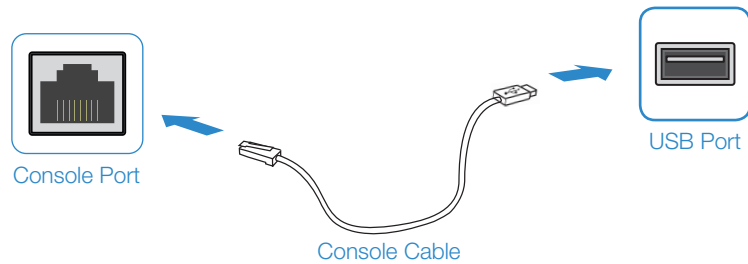

1. Connect the [Console Port](#) with a [console cable](#) to the [Serial Port](#) on the [Management Computer](#)
2. Start a [terminal program](#) on the [Management Computer](#) and select an available [COM Port](#) using the following default settings:

Baud rate: 9600
Data bits: 8
Parity: None
Stop bits: 1
Flow control: None

3. Log in using username [admin](#) and [no password](#)
4. You can now configure your FortiADC

Basic Settings

Please refer to the admin guide found on docs.fortinet.com for detailed instruction on configuring your FortiADC.

Basic Network Settings

1. Once you have installed your FortiADC and configured your management interface, we recommend setting the following:

- ✓ [Administrative password](#)
- ✓ [System time and date](#)
- ✓ [Network interfaces](#)
- ✓ [DNS](#)

2. Test the [connectivity](#) between devices
3. [Register](#) your product, if you haven't already
4. Install your [license](#) and update the [firmware](#)
5. Configure a basic [load balancing policy](#)
6. [Test the deployment](#) with a load to verify the system behavior
7. [Back up](#) your configuration to have as a restore point

Resources

Refer to the following resources to continue your FortiADC setup.

Fortinet Customer Service & Support

Create a support account, register and manage your products, download updates, firmware images and release notes, and create technical support tickets.

<https://support.fortinet.com>

Fortinet Document Library

Up-to-date versions of Fortinet publications for the entire family of Fortinet products.

<https://docs.fortinet.com>

Training Services

Course descriptions, availability, schedules, and location of training programs in your area.

<https://www.fortinet.com/support-and-training/training.html>

Technical Discussion Forums

Communicate with other customers and Fortinet partners about Fortinet products, services, and configuration issues.

<https://support.fortinet.com/forum>

FortiGuard Threat Research and Response

Up-to-date information on vulnerabilities and threats, includes a virus scanner, IP signature look-up, and web filtering tools.

<https://fortiguard.com>

Cautions and Warnings

Environmental Specifications

Ambient operating temperature: 0°C to 40°C

Rack Mount Instructions - The following or similar rack-mount instructions are included with the installation instructions:
Instructions de montage en rack - Les instructions de montage en rack suivantes ou similaires sont incluses avec les instructions d'installation:

Elevated Operating Ambient - If installed in a closed or multi-unit rack assembly, the operating ambient temperature of the rack environment may be greater than room ambient. Therefore, consideration should be given to installing the equipment in an environment compatible with the maximum ambient temperature (T_{ma}) specified by the manufacturer.

Température ambiante élevée - S'il est installé dans un rack fermé ou à unités multiples, la température ambiante de fonctionnement de l'environnement du rack peut être supérieure à la température ambiante de la pièce. Par conséquent, il est important d'installer le matériel dans un environnement respectant la température ambiante maximale (T_{ma}) stipulée par le fabricant.

Reduced Air Flow - Installation of the equipment in a rack should be such that the amount of air flow required for safe operation of the equipment is not compromised.

Ventilation réduite - Installation de l'équipement dans un rack doit être telle que la quantité de flux d'air nécessaire au bon fonctionnement de l'équipement n'est pas compromise.

Mechanical Loading - Mounting of the equipment in the rack should be such that a hazardous condition is not achieved due to uneven mechanical loading.

Chargement Mécanique - Montage de l'équipement dans le rack doit être telle qu'une situation dangereuse n'est pas liée à un chargement mécanique inégal.

Circuit Overloading - Consideration should be given to the connection of the equipment to the supply circuit and the effect that overloading of the circuits might have on overcurrent protection and supply wiring. Appropriate consideration of equipment nameplate ratings should be used when addressing this concern.

Surtenion - Il convient de prendre l'ensemble des précautions nécessaires lors du branchement de l'équipement au circuit d'alimentation et être particulièrement attentif aux effets de la suralimentation sur le dispositif assurant une protection contre les courts-circuits et le câblage. Ainsi, il est recommandé de tenir compte du numéro d'identification de l'équipement.

Reliable Earthing - Reliable earthing of rack-mounted equipment should be maintained. Particular attention should be given to supply connections other than direct connections to the branch circuit (e.g. use of power strips).

Fiabilité de la mise à la terre - Fiabilité de la mise à la terre de l'équipement monté en rack doit être maintenue. Une attention particulière devrait être accordée aux connexions d'alimentation autres que les connexions directes au circuit de dérivation (par exemple de l'utilisation de bandes de puissance).

Refer to specific Product Model Data Sheet for Environmental Specifications (Operating Temperature, Storage Temperature, Humidity, and Altitude)

Référez à la Fiche Technique de ce produit pour les caractéristiques environnementales (Température de fonctionnement, température de stockage, humidité et l'altitude).

Safety

Moving parts - Hazardous moving parts. Keep away from moving fan blades.

Pièces mobiles - Pièces mobiles dangereuses. Se tenir éloigné des lames mobiles du ventilateur.

Warning: Equipment intended for installation in Restricted Access Location.

Avertissement: Le matériel est conçu pour être installé dans un endroit où l'accès est restreint.

Warning: A readily accessible disconnect device shall be incorporated in the building installation wiring.

Avertissement: Un dispositif de déconnexion facilement accessible doit être incorporé dans l'installation électrique du bâtiment.

Warning: A UL Listed external disconnect device, i.e. circuit breaker or other, with over current protection suitable for local code (rated 25A recommended) shall be installed with this equipment

Avertissement: Un dispositif de déconnexion externe homologué UL, exemple d'un disjoncteur ou autre, avec des protections de surintensité appropriées (nominal 25A recommandé) à l'installation de ce matériel.

Battery - Risk of explosion if the battery is replaced by an incorrect type. Do not dispose of batteries in a fire. They may explode. Dispose of used batteries according to your local regulations. IMPORTANT: Switzerland: Annex 4.10 of SR814.013 applies to batteries.

Batterie - Risque d'explosion si la batterie est remplacée par un type incorrect. Ne jetez pas les batteries au feu. Ils peuvent exploser. Jetez les piles usagées conformément aux réglementations locales. IMPORTANT: Suisse: l'annexe 4.10 de SR814.013 s'appliquent aux batteries.

警告

本電池如果更換不正確會有爆炸的危險

請依製造商說明書處理用過之電池

CAUTION:

There is a danger of explosion if a battery is incorrect replaced. Replace only with the same or equivalent type.

Dispose batteries of according to the manufacturer's instructions.

Disposing a battery into fire, a hot oven, mechanically crushing, or cutting it can result in an explosion.

Leaving a battery in an extremely hot environment can result in leakage of flammable liquid, gas, or an explosion.

If a battery is subjected to extremely low air pressure, it may result in leakage of flammable liquid, gas, or an explosion.

WARNUNG:

Lithium-Batterie Achtung: Explosionsgefahr bei fehlerhafter Batteriewechsel. Ersetzen Sie nur den gleichen oder gleichwertigen Typ. Batterien gemäß den Anweisungen des Herstellers entsorgen.

Beseitigung einer BATTERIE in Feuer oder einen heißen Ofen oder mechanisches Zerkleinern oder Schneiden einer BATTERIE, die zu einer EXPLOSION führen kann

Verlassen einer BATTERIE in einer extrem hohen Umgebungstemperatur, die zu einer EXPLOSION oder zum Austreten von brennbarer Flüssigkeit oder Gas führen kann

Eine BATTERIE, die einem extrem niedrigen Luftdruck ausgesetzt ist, der zu einer EXPLOSION oder zum Austreten von brennbarer Flüssigkeit oder Gas führen kann.

CAUTION: Shock Hazard. Disconnect all power sources.
ATTENTION: Risque d'électrocution. Débranchez toutes les sources d'alimentation.

Caution: Slide/rail mounted equipment is not to be used as a shelf or a work space.

Attention: Un équipement monté sur bâti ne doit pas être utilisé sur une étagère ou dans un espace de travail.

Warning: Stability hazard.
Aviso: Perigo de estabilidade.

The rack may tip over causing serious personal injury.
O rack pode tombar causando ferimentos graves.

Before extending the rack to the installation position, read the installation instructions.
Antes de estender o rack para a posição de instalação, leia as instruções de instalação.

Do not put any load on the slide-rail mounted equipment in the installation position.
Não coloque nenhuma carga no equipamento montado em trilho deslizando na posição de instalação.

Do not put any load on the slide-rail mounted equipment in the installation position.
Não coloque nenhuma carga no equipamento montado em trilho deslizando na posição de instalação.

Do not leave the slide-rail mounted equipment in the installation position.
Não deixe o equipamento montado em trilho deslizando na posição de instalação.

Regulatory Compliance

Federal Communication Commission (FCC) – USA

This device complies with Part 15 of the FCC Rules. Operation is subject to the following two conditions:
(1) this device may not cause harmful interference, and
(2) this device must accept any interference received, including interference that may cause undesired operation.

This equipment has been tested and found to comply with the limits for a Class A digital device, pursuant to Part 15 of the FCC Rules. These limits are designed to provide reasonable protection against harmful interference when the equipment is operated in a commercial environment. This equipment generates, uses, and can radiate radio frequency energy, and if it is not installed and used in accordance with the instruction manual, it may cause harmful interference to radio communications. Operation of this equipment in a residential area is likely to cause harmful interference, in which case the user will be required to correct the interference at his own expense.

WARNING: Any changes or modifications to this product not expressly approved by the party responsible for compliance could void the user's authority to operate the equipment.

Industry Canada Equipment Standard for Digital Equipment (ICES) – Canada

CAN ICES-003 (A) / NMB-003 (A)

This digital apparatus does not exceed the Class A limits for radio noise emissions from digital apparatus set out in the Radio Interference Regulations of the Canadian Department of Communications.

Cet appareil numérique n'émet pas de bruits radioélectriques dépassant les limites applicables aux appareils numériques de la classe A prescrites dans le Règlement sur le brouillage radioélectrique édicté par le ministère des Communications du Canada.

European Conformity (CE) - EU

This is a Class A product. In a domestic environment, this product may cause radio interference, in which case the user may be required to take adequate measures.



Voluntary Control Council for Interference (VCCI) – Japan

この装置は、クラスA 機器です。この装置を住宅環境で使用すると電波妨害を引き起こすことがあります。この場合には使用者が適切な対策を講ずるよう要求されることがあります

V C C I – A

Product Safety Electrical Appliance & Material (PSE) – Japan

日本では電気用品安全法(PSE)の規定により、同梱している電源コードは本製品の専用電源コードとして利用し、他の製品に使用しないでください。

Bureau of Standards Metrology and Inspection (BSMI) – Taiwan

The presence conditions of the restricted substance (BSMI RoHS table) are available at the link below:
限用物質含有情況表 (RoHS Table) 請到以下 網址下載:
<https://www.fortinet.com/bsmi>

警告： 為避免電磁干擾，本產品不應安裝或使用於住宅環境。

請仔細閱讀以下說明
本設備勿置於潮濕處。
連接至電源前，請先檢查電壓。
當設備不用時，請將所有電源線拔除，避免電壓不穩而造成傷害。

勿將任何液體澆入設備中，避免線路短路。
基於安全理由，只有受到專業訓練的從業人員，才可以打開本設備。
請勿自行調整或修理已通電的設備，以確保您的安全。
如不小心受傷，請立刻找急救人員給予您適當的救護，千萬別因傷勢輕微而忽略自己的傷勢。

請依照台灣法規處置電池。
若不正確替換電池可能導致爆炸危險，替換電池時，請使用設備生產商推薦使用的電池。
請勿拆卸、刺穿或以其他方式損壞電池。

雷射設備非用戶維修設備，請與生產商聯繫維修事宜。

注意：要斷開電源，請將所有電源線從本機上拔下

英屬蓋曼群島商防特網股份有限公司台灣分公司
地址：台北市內湖區行愛路176號2樓
電話：(02) 27961666

China

此为A级产品，在生活环境中，该产品可能会造成无线电干扰。这种情况下，可能需要用户对其采取切实可行的措施。

FORTINET®

[Fortinet.com](https://www.fortinet.com)