



Model Number

Q11

4U Active Cooler

PRODUCT SPECIFICATIONS

Rev_4.0_July 27, 2023

Table of Contents

1.	REVISION HISTORY	3
2.	PRODUCT DESCRIPTION	4
3.	THERMAL PERFORMANCE CURVE.....	5 ~ 6
4.	ASSEMBLY DRAWING	7
5.	DIMENSION DRAWING	8
6.	COOLING FAN SPECIFICATION	9 ~ 16
7.	RoHS CERTIFICATION	17

Document History List

Rev 0.0, Dec. 06, 2022: Initial release

Rev 1.0, Jan. 25, 2023: Update Thermal Performance Chart, Page 6

Rev 2.0, Jan. 30, 2023: Update Cooling Fan Specification, Page 9

Rev 3.0, Mar.21, 2023: Update Noise Level Specification, Page 4,6,10

Rev 4.0, July 27, 2023: Update thermal performance, Page 6

Model Number: Q11

- Recommend for Intel® CPU as following
 - Support Intel Core 12th -15th Gen, Socket LGA1700/1851
- Active Cooler for 4U Server & Up

Overall Specification

Dimension (LWH)	95 x 95 x 130 mm
Weight	710 g
Material	Heatpipes with Aluminum Base and Aluminum Fin Stack
Fan	103 x 30 Side-blow fan with PWM Function
Mounting Method	Intel LGA1700 standard Mounting with Screw Sets
Backing Plate	Included
Thermal Grease	SHIT-ETSU 7762 or Equivalent
TDP	Support CPU Power 170 Watts Heat Dissipation at 30°C ambient temperature

Cooling Fan Specification

Model Number	DF10330BL - PWM
Dimension	103 x 103 x 30 mm
Bearing	Double Ball
Rated Voltage	12V
Rated Speed	At Duty Cycle 0~20%: 800± 200 RPM At Duty Cycle 50%: 1300± 10% RPM At Duty Cycle 100%: 1800±10% RPM
Input Power	At Duty Cycle 0~20%: 0.30W At Duty Cycle 50%: 0.48W At Duty Cycle 100%: 0.96W
Maximum Airflow	At Duty Cycle 0~20%: 14.88 CFM At Duty Cycle 50%: 25.26 CFM At Duty Cycle 100%: 35.03 CFM
Rated Static Pressure	At Duty Cycle 0~20%: 0.44 mm-H2O At Duty Cycle 50%: 1.16 mm-H2O At Duty Cycle 100%: 2.06 mm-H2O
Acoustical Noise	At Duty Cycle 0~20%: 10.8 dBA At Duty Cycle 50%: 15.2 dBA At Duty Cycle 100%: 21.3 dBA
Lead Wire Pin Out	Pin#1- Black (-) Pin#2- Black (+) Pin#3- Black (Tachometer/ Signal Output) Pin#4- Black (PWM Control)

Q11 | Socket LGA1700

Lead Wire Pin Out Diagram :

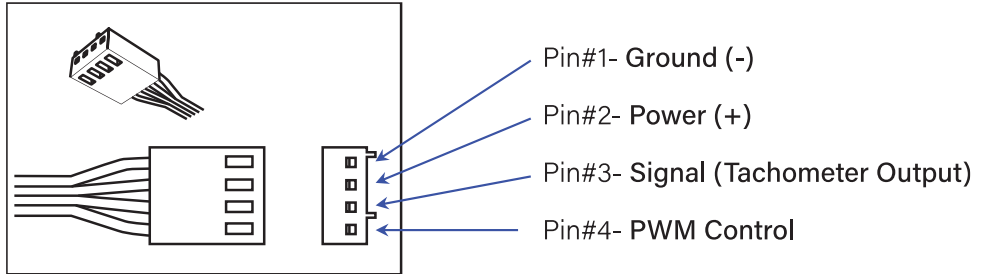

Cooling Fan P-Q Curve at 1800 RPM

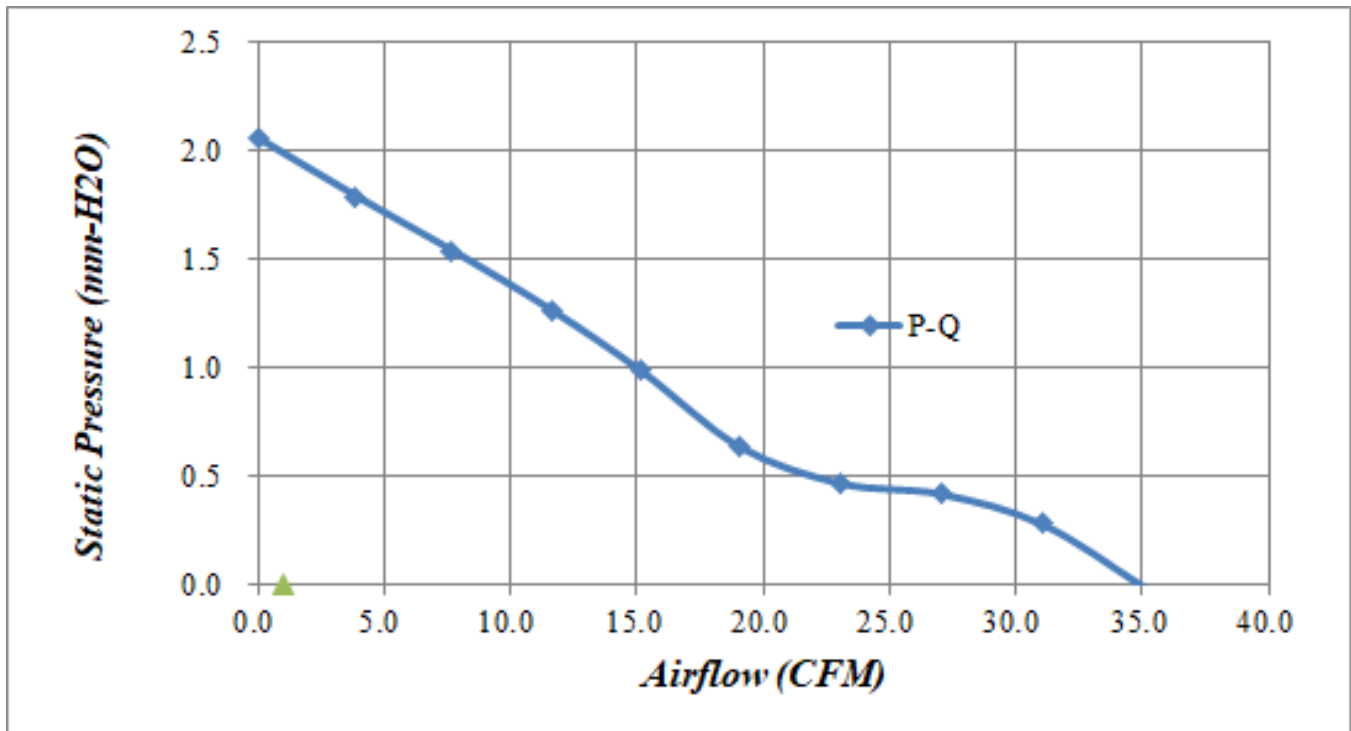

Performance Chart: Active Cooler Q11 Thermal Resistance Thermal Resistance vs. Fan Speed (Duty Cycle and RPM)

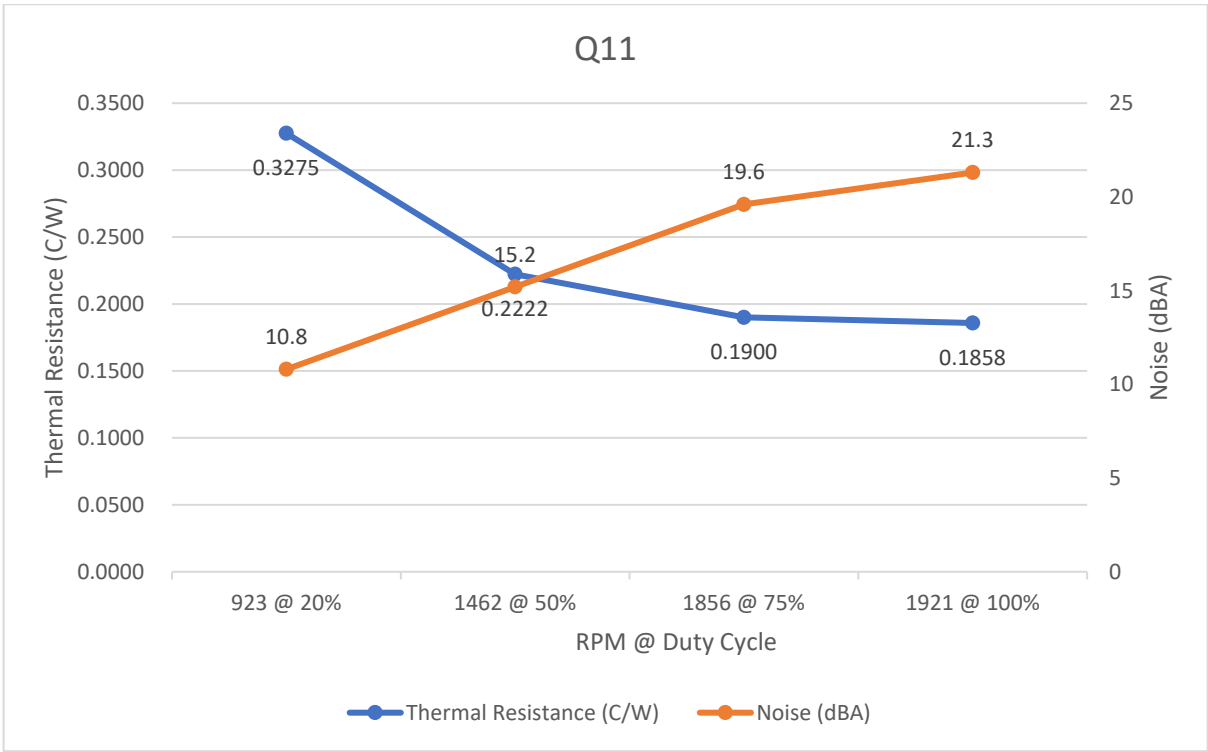

REV#	DESCRIPTION	CHECKER	DATE
0.0	Initial Release	LANG	12/06/2022

ASSEMBLY PARTS

WHOLE SET OF HEATSINK

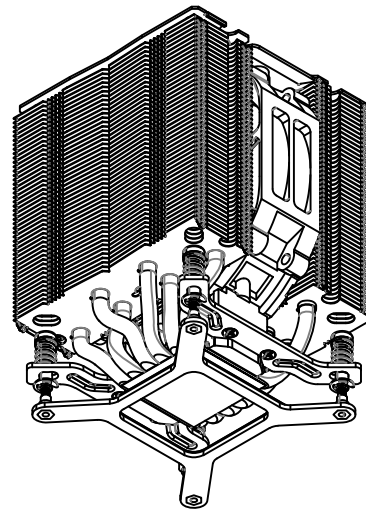
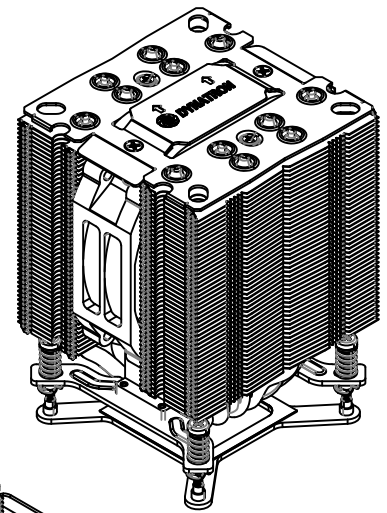
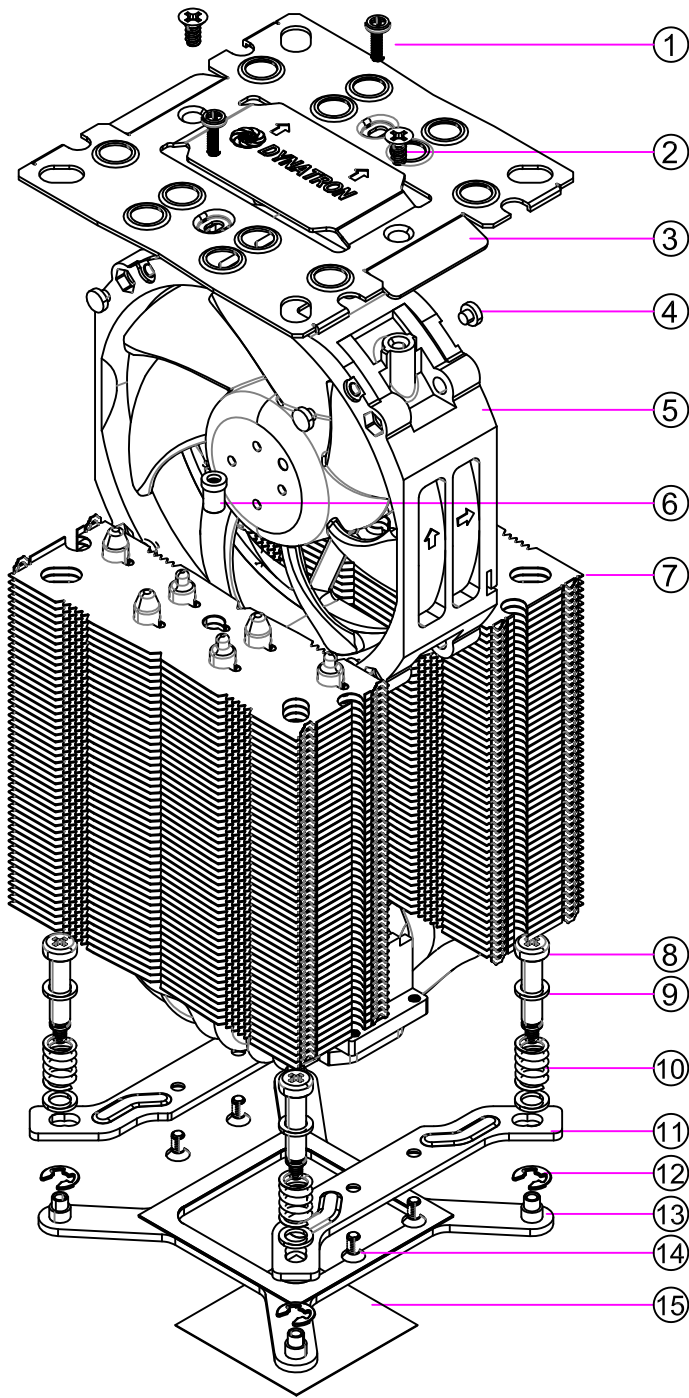

15	THERMAL GREASE, PRE-PRINT, 38*38* THK 0.2 mm	SHIN-ETSU 7762	1
14	SCREW, HEATSINK RETENTION MOUNTING (1920)	STEEL	4
13	BACKPLATE, FOR SOCKET LGA1700	SPCC	1
12	C-CLIP	STEEL	4
11	RETENTION, FOR INTEL SOCKET LGA1700	SK7	2
10	SPRING (0960)	SUS304	4
9	WASHER	STEEL	8
8	SCREW, HEATSINK MOUNTING (1200)	STEEL	4
7	HEATSINK, STACKED FIN	ALUMINUM BASE ALUMINUM FINS (6x) HEATPIPE	1
6	STUD, TOP COVER MOUNTING, M3*0.5 THREADED	ALUMINUM	2
5	COOLING FAN, 103mm x 103mm x 30mm	PBT	1
4	ANTI-VIBRATION BOOT	RUBBER PLASTIC	4
3	TOP COVER, THK 1.0 mm, BLACK NICKEL PLATED	SPCC	1
2	SCREW, COOLING FAN MOUNTING Ø3.5 mm SELF-TAPPING THREADS	STEEL	2
1	SCREW, COVER MOUNTING, M3*0.5 x 9 mm L	STEEL	2
ITEM#	DESCRIPTION	MATERIAL	QTY.

	NAME	DATE
DRAWN BY	engr	12/06/2022
CHECKED BY	LANG	12/06/2022
ENG.APPROVED		
MFG.APPROVED	-	-



DYNATRON CORPORATION

TOP MOTOR

TITLE: 4U Active Cooler Model **Q11**
(sample LG802)
for Intel Socket LGA1700
Overall Dimension Drawing

CONFIDENTIAL DOCUMENT

THIS DRAWING CONTAINS INFORMATION PROPRIETARY TO DYNATRON CORPORATION AND DYNAEON INDUSTRIAL CO., LTD. ANY REPRODUCTION, DISCLOSURE, OR USE OF THIS DRAWING IS EXPRESSLY PROHIBITED EXCEPT AS DYNATRON CORPORATION AND DYNAEON INDUSTRIAL CO., LTD. MAY OTHERWISE AGREE TO IN WRITING.

VIEW		DWG. No:	REV.
UNITS	MM	DYN - EP - Q11	0.0

REV#	DESCRIPTION	CHECKER	DATE
0.0	Initial Release	LANG	12/06/2022

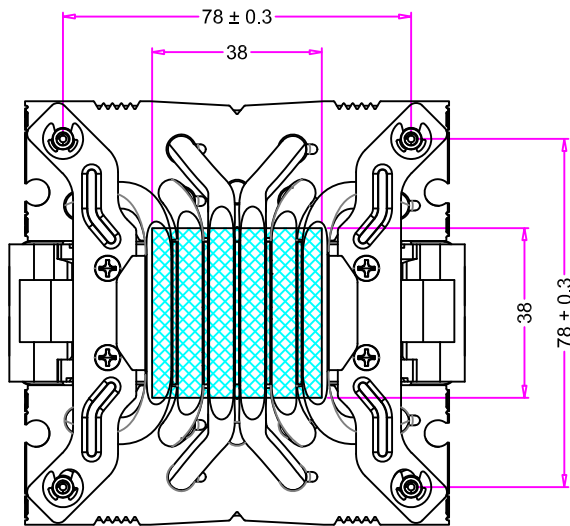
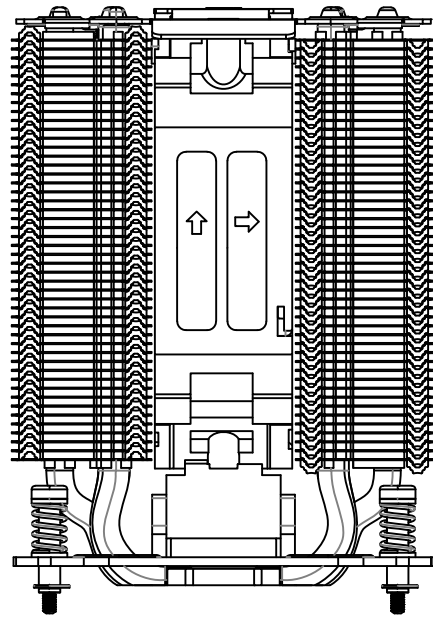
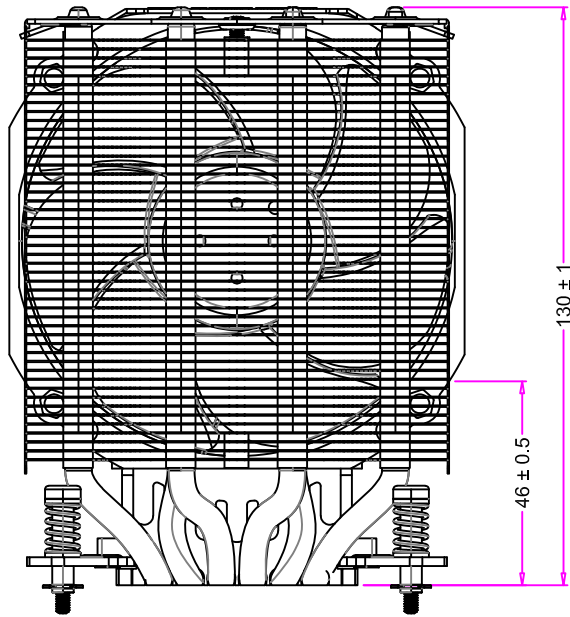
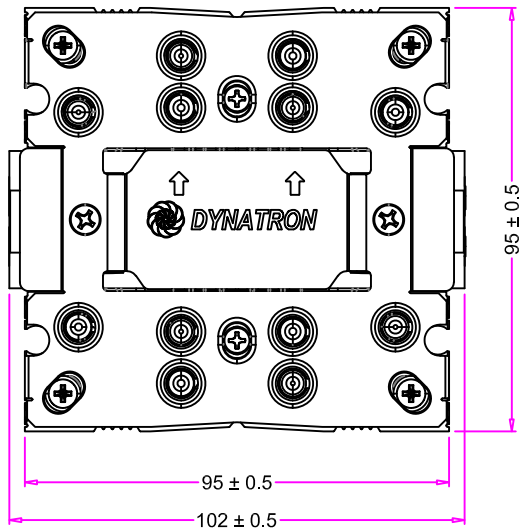

	NAME	DATE
DRAWN BY	engr	12/06/2022
CHECKED BY	LANG	12/06/2022
ENG.APPROVED		
MFG.APPROVED	-	-

DYNATRON CORPORATION
 TOP MOTOR

TITLE: 4U Active Cooler Model **Q11**
(sample LG802)
Overall Dimension Drawing

CONFIDENTIAL DOCUMENT
 THIS DRAWING CONTAINS INFORMATION PROPRIETARY TO DYNATRON CORPORATION AND DYNAEON INDUSTRIAL CO., LTD. ANY REPRODUCTION, DISCLOSURE, OR USE OF THIS DRAWING IS EXPRESSLY PROHIBITED EXCEPT AS DYNATRON CORPORATION AND DYNAEON INDUSTRIAL CO., LTD. MAY OTHERWISE AGREE TO IN WRITING.

VIEW		DWG. No:	REV.
UNITS	MM	DYN - DM - Q11	0.0



DYNATRON CORPORATION

TOP MOTOR TECHNOLOGY (HUIZHOU) CO, LTD

Specification for Approval

Customer:		
Model Number:	DF10330BL (103*103*30mm)	
Part Number:		
Issued Date:	Monday, January 30, 2023	
Version:	A	
Customer Approval		
Approval:	Check:	
Corporate Headquarters Dynatron Corporation 33200 Western Avenue Union City, CA 94587 U.S.A. Tel: 510-498-8888 Fax: 510-498-8488	<i>Taipei Office</i> (Taiwan, R.O.C.) 8F, No. 35, Lane:221 Gang Cian. Road, Taipei, Taiwan, R.O.C. Tel: 886-2-27995799 (Rep.) Fax: 886-2-2799-9577	Manufactory TOP MOTOR TECHNOLOGY(HUI ZHOU)CO,LTD Baishi Village, QiuchangTown, Huiyang Dist, HuizhouCity, Guangdong Province, P.R. China Tel: 86-752-822-8000 (Rep.) Fax: 86-752-822-8999
Approval:	Check:	Handler:
GLEN	-	MARTIN



DYNATRON CORPORATION

TOP MOTOR TECHNOLOGY (HUIZHOU) CO, LTD

1. SCOPE

This specification defines the electrical and mechanical characteristics of the
 ■ DC Brush less(■2-Balls Bearing)axial flow fan, which is carefully designed and manufactured for your special needs by Dynatron Corporation.

2. ELECTRICAL CHARACTERISTICS

Items		Description		
1.	Rated Voltage	DC 12 V		
2.	Operating Voltage	DC 10.9 V ~ 13.2 V		
3.	PWM Frequency 25KHz	Duty Cycle D=0%-20%	Duty Cycle D=50%	Duty Cycle D=100%
4.	Start Voltage	DC 7V		
5.	Air Flow – At rated voltage zero static pressure (minimal value)	0.421m ³ /min (14.88CFM)	0.715m ³ / min (25.26CFM)	0.992m ³ / min (35.03CFM)
6.	Static Pressure – At rated voltage At zero air flow	0.44mm-H2O (0.017inch-H2O)	1.16mm-H2O (0.046inch-H2O)	2.06mm-H2O (0.081inch-H2O)
7.	Input Current (Max.)	0.025A	0.04A	0.08A
8.	Input Power (Max.)	0.30W	0.48W	0.96W
9.	Speed	800 RPM ±200	1300 RPM ±10%	1800 RPM ±10%
10.	Acoustical Noise	10.8dBA	15.2dBA	21.3dBA
11.	Insulation Resistance – Between Frame and Terminal	10 M ohm at DC 500 V		
12.	Dielectric Strength – Between Frame and Terminal	5 mA (Max.) @ AC 500 V 60 Hz 1 min.		
13.	Life – Continuous operating under normal temperature (40 °C or 104°F)	70,000 hours		
14.	Rotation	Clockwise Air Discharged		
15.	Lead Wires	UL 1061, AWG 26 or Equivalent “-”: Black; “+”: Black “s”: Black. “PWM”: Black.		



DYNATRON CORPORATION

TOP MOTOR TECHNOLOGY (HUIZHOU) CO, LTD

3. MECHANICAL CHARACTERISTICS

Items		Description
1.	Dimension	Display as Drawing
2.	Frame	PBT UL94V-0 (Black GP)
3.	Impeller	PBT UL94V-0 (Black GP)
4.	Bearing System	2-Balls Bearing
5.	Weight	136 ±10grams

4. ENVIRONMENTAL

Items		Description
1.	Operating Temperature	- 10 °C ~ + 65 °C (65 %RH)
2.	Storage Temperature	- 30 °C ~ + 70 °C (65 %RH)
3.	Vibration Test	Motor withstands 1000 rpm vibrating with 2 mm amplitude for 30 minutes up and down, right and left, back and forth directions.
4.	Drop Test	Motor withstands one free body drop from 30 cm in high onto 10 mm thickness of wooden board for each of the three faces in minimum packing condition.
5.	Acoustic Noise	Measuring Condition – Under rated voltage in semi-anechoic chamber equipment sound level meter. (Figure A.)

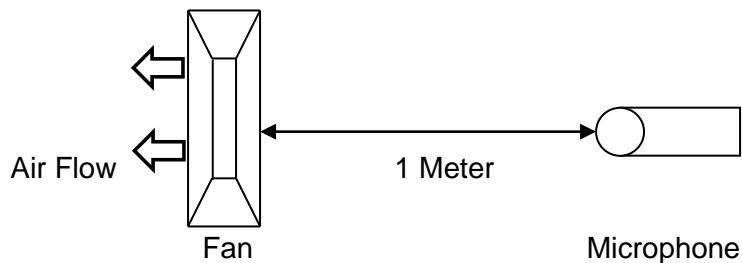

Figure A – Noise Level is measure at rated voltage in anechoic chamber in free air as above.



DYNATRON CORPORATION

TOP MOTOR TECHNOLOGY (HUIZHOU) CO, LTD

5. PROTECTION

Items		Description
1.	Polarity Protection	For polarity error connection to power, the circuit withstands reversed connection between positive and negative leads.
2.	Locked Rotor Protection	Motor winding protects the motor from damage in 72 hours of locked rotor condition at rated voltage.

6. ATTACHMENTS

- 6.1. Product Dimension
- 6.2. Frequency Generator Output
- 6.3. Electrical specifications for pwm production



DYNATRON CORPORATION

TOP MOTOR TECHNOLOGY (HUIZHOU) CO, LTD

6.1. Product Dimension

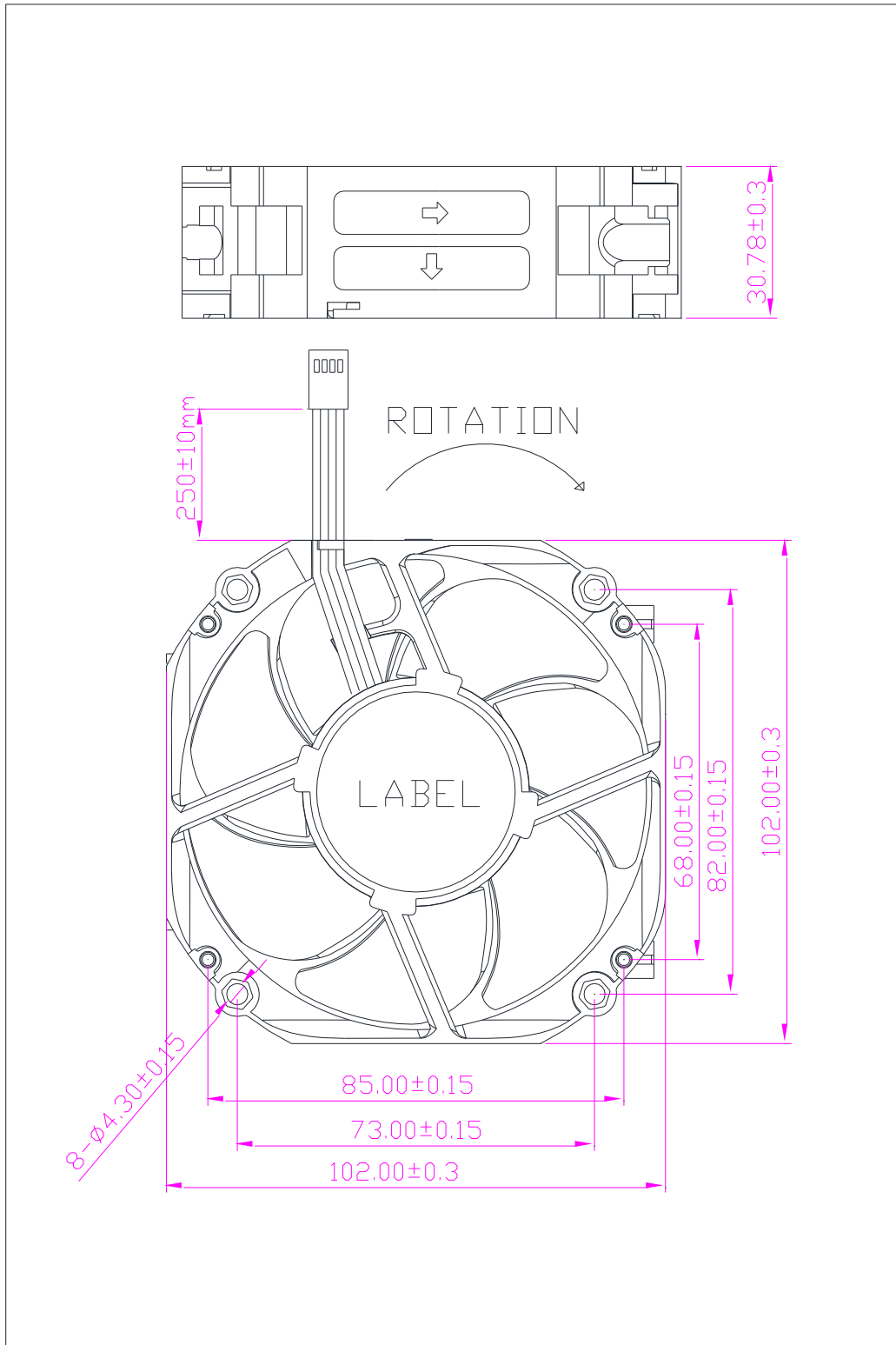



DYNATRON CORPORATION

TOP MOTOR TECHNOLOGY (HUIZHOU) CO, LTD

6.2. Frequency Generator Output

FREQUENCY GENERATOR O/P:

Frequency generator function is activated by an internal IC for customer's application.
Electrical schematic:

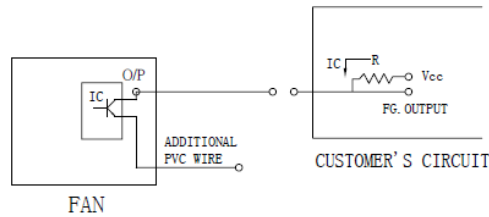

CUSTOMER'S CIRCUIT

V_{cc} = From +5 To +28 VDC (Generally using +12 or +24 VDC)

I_c = 5 mA max.

$R = V/I$ (Output "R" value calculation)

● SUPPLY A WAVEFORM:

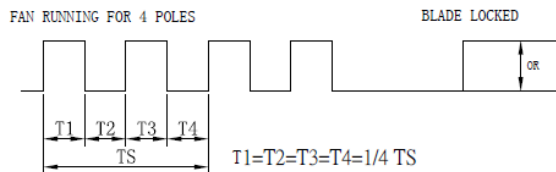

$N=R.P.M.$ (Rotation speed will be different for various models
L/M/H/HH/VH/SH)

$TS=60/N$ (Sec)

* Voltage level after blade locked

● OUTPUT LEVEL:

High = V_{cc} 10%

Low = 0~0.5V

I_c = 5 mA max.

● APPLICATION:

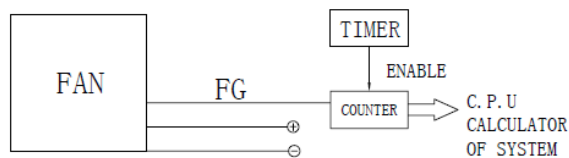

● FUNCTIONS:

. By means of waveform & customer's design, schematic can reach alarm function, either in the form of buzzing or LED flashing.
Adjust rotation speed.

. When power supply output voltage level decreases, it will result in the lowering of fan rotation speed. The irregular situation will be controlled by using FG. O/P through P/S circuit to increase the output voltage and result in a stable rotation speed.



DYNATRON CORPORATION

TOP MOTOR TECHNOLOGY (HUIZHOU) CO, LTD

6.3. Electrical specifications for pwm production

USA Dynatron Corp.

Electrical Specifications for PWM production

Voltage

Fan operating voltage shall be within the range 12V \pm 1.2V.

Current

Peak fan current draw during start-up operation(with 13.2V applied,with fan operating in the free stream condition)shall not exceed 2.0 A.

Fan current spike during start-up operation(with 13.2V applied with fan operating in the free stream condition)shall be allowed to exceed 1.0 A for a duration of no greater than 1.0 sec.

Tachometer Output Signal

Fan shall provide tachometer output signal with the following characteristics:

- * Two pulses per revolution
- * Open-collector or open-drain type output
- * Motherboard will have a pull up to 12V, maximum 13.2V

PWM Control Input Signal

The following requirements are measured at the PWM(control) pin of the fan cable connector: PWM Frequency: Target frequency 25kHz,

acceptable operational range 21 kHz to 28 KHz

Maximum voltage for logic low: VIL=0.8V

Absolute maximum current sourced: I_{max}=5mA(short circuit current)

Absolute maximum voltage level: V_{max}=5.25V(open circuit voltage)

Fan Speed Control

1.1 Maximum Fan Speed Requirements

The maximum fan speed shall be specified for the fan model by the vendor and correspond to 100% duty cycle PWM signal input.

1.2 Minimum Fan Speed Requirements

The vendor shall specify the minimum RPM and the corresponding PWM duty cycle. This specified minimum RPM shall be 30% of maximum RPM or less. The fan shall be able to start and run at this RPM. To allow a lower specified minimum RPM, it is acceptable to provide a higher PWM duty cycle to the fan motor for a short period of time for startup conditions. This pulse should not exceed 30% maximum RPM and should last no longer than 2 seconds.



DYNATRON CORPORATION

TOP MOTOR TECHNOLOGY (HUIZHOU) CO, LTD

USA Dynatron Corp.

1.3 Fan Speed Response PWM Control Input Signal

The PWM input shall be delivered to the fan through the control signal on Pin4. Fan speed response to this signal shall be a continuous and monotonic of the duty cycle of the signal, from 100% to the minimum specified RPM. The fan RPM (as a percentage of maximum RPM) should match the PWM duty cycle within $\pm 10\%$. If no control signal is present the fan shall operate at maximum RPM.

Figure 1 Fan speed Response to PWM Control input Signal

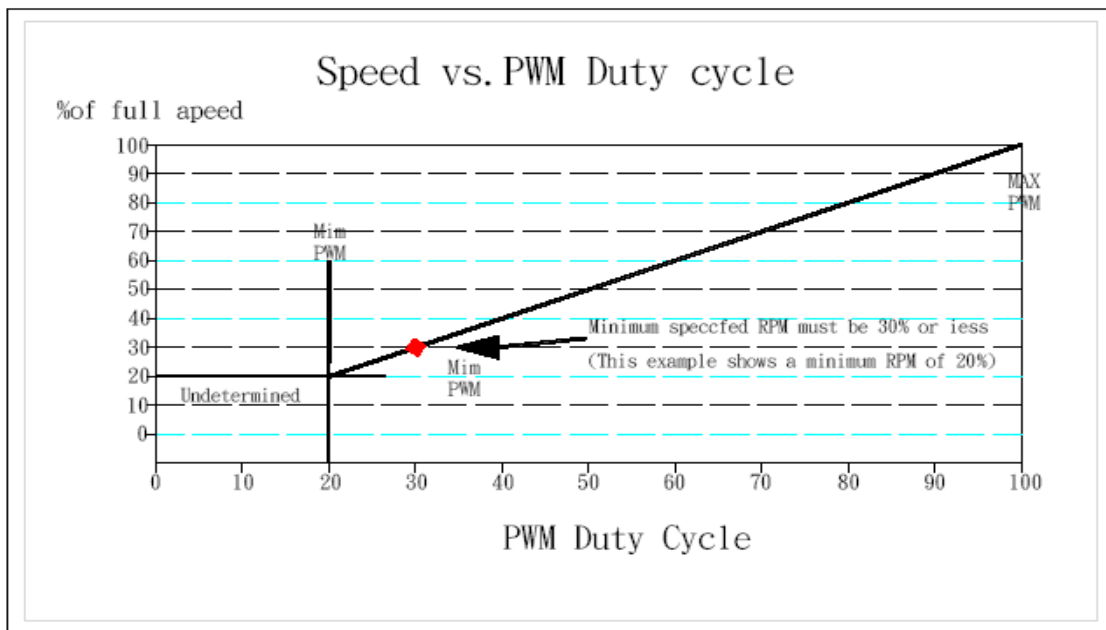

1.4 Operation Below Minimum RPM

For all duty cycles less than the minimum duty cycle, the RPM shall not be greater than the minimum RPM. The following graphs and definitions show three recommended solutions to handle PWM duty cycles that are less than the minimum operational PWM, as a percentage of maximum.

Reference resource by Intel's 4-wire PWM Fan controlled specification.



Certificate of Environment Protection

環保證明書

Document Number: RH-Q11-R0

Customer: 客戶名稱:	Company: Address: _____ Phone Number: _____ - _____ - _____
Issue Date: 發行日期:	12 / 06 / 2022
Product Model Number: 產品號碼:	Q11

Dynatron Corporation / Dynaeon Industrial Co., Ltd hereby declares and certifies that all components manufactured are RoHS, ROHS2 & ROHS3 compliant according to the definitions and restrictions given by the European Union's Restriction (Directive 2002/95/EC) (Directive 2011/65/EU) & (Directive (EU) 2015/863) as known as RoHS 3, on the restriction of the use of certain Hazardous Substances in the electrical and electronic equipment.

No exemptions are claimed in order for the part to be compliant with the RoHS directive.

Dynatron Corporation / 政久興業股份有限公司證明所有產品,零件 (包括附屬品,包裝類) 之環境管理物質完全符合 RoHS, WEEE, 及該環保標準之規定, 並承諾遵循以上之證明.

Dynatron Corporation / Dynaeon Industrial Co., Ltd.

Title (職務): _____ ASSISTANT-MANAGER / 副理 _____

Signature (簽字): _____

Date: 12 / 06 / 2022