

NTTP61CA-AO

Ciena® NTTP61CA Compatible TAA 10/100/1000Base-TX SFP Transceiver (Copper, 100m, RJ-45, Rugged)

Features

- INF-8074 Compliance
- RJ-45 Connector
- Industrial Temperature -40 to 85 Celsius
- Copper Media Type
- Hot Pluggable
- Excellent ESD Protection
- Metal with Lower EMI
- RoHS Compliant and Lead Free



Applications

- 1000Base Ethernet
- Access and Enterprise

Product Description

This Ciena® NTTP61CA compatible SFP transceiver provides 10/100/1000Base-TX throughput up to 100m over a copper connection via a RJ-45 connector. This TX module supports 10/100/1000Base auto-negotiation and can be configured to fit your needs. It is guaranteed to be 100% compatible with the equivalent Ciena® transceiver. This easy to install, hot swappable transceiver has been programmed, uniquely serialized and data-traffic and application tested to ensure that it will initialize and perform identically. It is built to meet or exceed the specifications of Ciena®, as well as to comply with MSA (Multi-Source Agreement) standards to ensure seamless network integration. This transceiver is Trade Agreements Act (TAA) compliant. We stand behind the quality of our products and proudly offer a limited lifetime warranty.

AddOn's transceivers are RoHS compliant and lead-free.

TAA refers to the Trade Agreements Act (19 U.S.C. & 2501-2581), which is intended to foster fair and open international trade. TAA requires that the U.S. Government may acquire only "U.S. – made or designated country end products."



Absolute Maximum Ratings

Parameter	Symbol	Min.	Typ.	Max.	Unit	Notes
Data Rate	DR	10		1000	Mb/sec	2
Cable Length	CL			100	m	3
Bit Error Rate	BER			10		
Operating Temperature	TOP	-40		85	°C	4
Storage Temperature	TSTO	-40		85	°C	5
Supply Current	IS		320	375	mA	6
Input Voltage	VCC	3.14	3.3	3.46	V	7
Maximum Voltage	VMAX			4	V	6

Notes:

1. IEEE 802.3 compatible
2. Category 5 UTP
3. Case Temperature
4. Ambient Temperature
5. For electrical power interface
6. Referenced to GND. For electrical power interface

Electrical Characteristics

Parameter	Symbol	Min.	Typ.	Max.	Unit	Notes	
High Speed Electrical Interface Host-SFP							
Single ended Input Swing	V _{IN}	250		1200	mV	1	
Single ended output Swing	V _{OUT}	275		800	mV	1	
Rise time (20%-80%)	T _R		175		ps		
Fall Time (20%-80%)	T _F		175		ps		
Tx Input Impedance	Z _{IN}		50		ohm	1	
Rx Output Impedance	Z _{OUT}		50		ohm	1	
High Speed Electrical Interface Transmission Line-SFP							
Line Frequency	F _L		125		MHz	2	
Tx Output Impedance Differential	Z _{OUT_TX}		100		Ohm	3	
Rx Input Impedance Differential	Z _{IN_RX}		100		Ohm	3	
Low Speed Electrical Signal							
SFP Output	Low	V _{OL}	0		0.5	V	4
	High	V _{OH}	Host_Vcc -0.5		Host_Vcc +0.3	V	4
SFP Input	Low	V _{IL}	0		0.8	V	4
	High	V _{IH}	2		VCC + 0.3	V	4

Notes:

1. Single ended
2. 5-level encoding
3. For all frequencies between 1MHz and 125MHz
4. External 4.7-10k ohm pull-up resistor required

Pin Descriptions

Pin	Symbol	Name/Descriptions	Ref.
1	VEET	Transmitter ground (common with receiver ground)	1
2	TX_FAULT	Transmitter Fault. Not supported	
3	TX_DISABLE	Transmitter Disable. PHY disabled on high or open	2
4	MOD_DEF (2)	Module Definition 2. Data line for serial ID	3
5	MOD_DEF (1)	Module Definition 1. Clock line for serial ID	3
6	MOD_DEF (0)	Module Definition 0. Grounded within the module	3
7	Rate Select	No connection required	
8	RX_LOS	Loss of Signal	
9	VEER	Receiver ground (common with transmitter ground)	1
10	VEER	Receiver ground (common with transmitter ground)	1
11	VEER	Receiver ground (common with transmitter ground)	1
12	RD-	Receiver Inverted DATA out. AC coupled	
13	RD+	Receiver Non-inverted DATA out. AC coupled	
14	VEER	Receiver ground (common with transmitter ground)	1
15	VCCR	Receiver power supply	
16	VCCT	Transmitter power supply	
17	VEET	Transmitter ground (common with receiver ground)	1
18	TD+	Transmitter Non-Inverted DATA in. AC coupled	
19	TD-	Transmitter Inverted DATA in. AC coupled	
20	VEET	Transmitter ground (common with receiver ground)	1

Notes:

1. Circuit ground is connected to chassis ground
2. Disabled: TX_DISABLE > 2V or open, Enabled: TX_DISABLE < 0.8V
3. Should be pulled up with 4.7k-10k ohm on host board to a voltage between 2V and 3.6V

Electrical Pad Layout

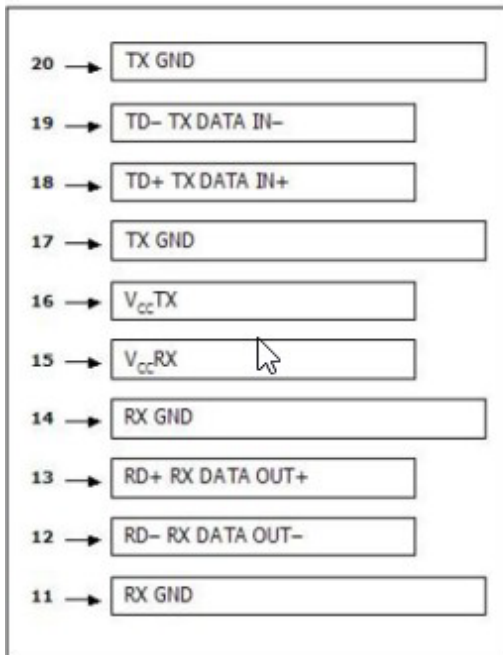
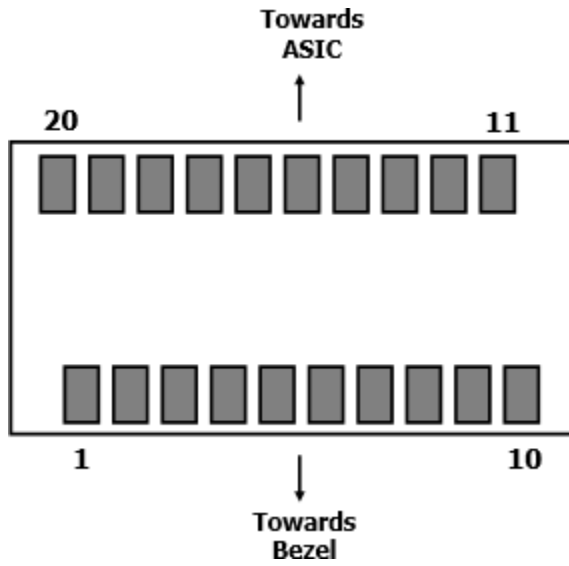

Top of Board

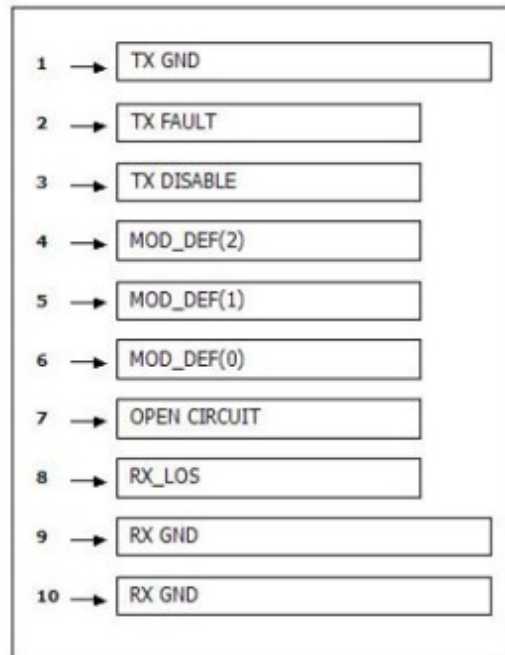

Bottom of Board

Mechanical Specifications

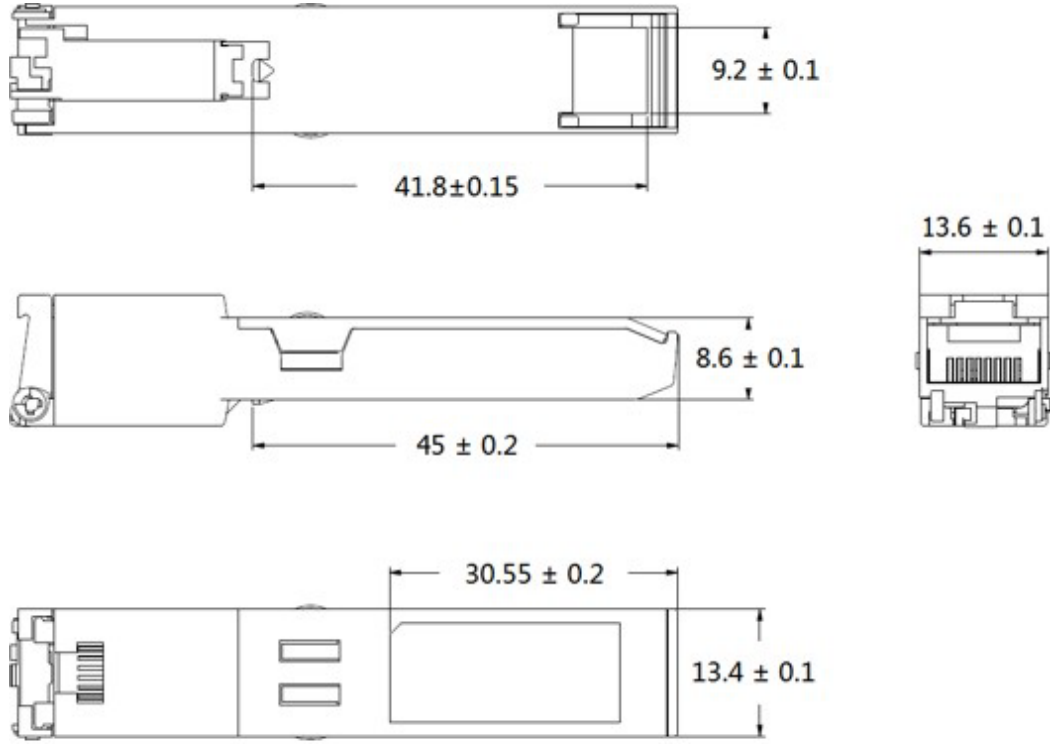

UNIT: mm

About AddOn Networks

In 1999, AddOn Networks entered the market with a single product. Our founders fulfilled a severe shortage for compatible, cost-effective optical transceivers that compete at the same performance levels as leading OEM manufacturers. Adhering to the idea of redefining service and product quality not previously had in the fiber optic networking industry, AddOn invested resources in solution design, production, fulfillment, and global support.

Combining one of the most extensive and stringent testing processes in the industry, an exceptional free tech support center, and a consistent roll-out of innovative technologies, AddOn has continually set industry standards of quality and reliability throughout its history.

Reliability is the cornerstone of any optical fiber network and is engrained in AddOn's DNA. It has played a key role in nurturing the long-term relationships developed over the years with customers. AddOn remains committed to exceeding industry standards with certifications from ranging from NEBS Level 3 to ISO 9001:2005 with every new development while maintaining the signature reliability of its products.



U.S. Headquarters

Email: sales@addonnetworks.com

Telephone: +1 877.292.1701

Fax: 949.266.9273

Europe Headquarters

Email: salesupportemea@addonnetworks.com

Telephone: +44 1285 842070