

E21569

First Edition / March 2023

IN SEARCH OF INCREDIBLE



Service Manual

ASUS

COPYRIGHT INFORMATION

No part of this manual, including the products and software described in it, may be reproduced, transmitted, transcribed, stored in a retrieval system, or translated into any language in any form or by any means, except documentation kept by the purchaser for backup purposes, without the express written permission of ASUSTeK COMPUTER INC. ("ASUS").

ASUS PROVIDES THIS MANUAL "AS IS" WITHOUT WARRANTY OF ANY KIND, EITHER EXPRESS OR IMPLIED, INCLUDING BUT NOT LIMITED TO THE IMPLIED WARRANTIES OR CONDITIONS OF MERCHANTABILITY OR FITNESS FOR A PARTICULAR PURPOSE. IN NO EVENT SHALL ASUS, ITS DIRECTORS, OFFICERS, EMPLOYEES OR AGENTS BE LIABLE FOR ANY INDIRECT, SPECIAL, INCIDENTAL, OR CONSEQUENTIAL DAMAGES (INCLUDING DAMAGES FOR LOSS OF PROFITS, LOSS OF BUSINESS, LOSS OF USE OR DATA, INTERRUPTION OF BUSINESS AND THE LIKE), EVEN IF ASUS HAS BEEN ADVISED OF THE POSSIBILITY OF SUCH DAMAGES ARISING FROM ANY DEFECT OR ERROR IN THIS MANUAL OR PRODUCT.

Products and corporate names appearing in this manual may or may not be registered trademarks or copyrights of their respective companies, and are used only for identification or explanation and to the owners' benefit, without intent to infringe.

SPECIFICATIONS AND INFORMATION CONTAINED IN THIS MANUAL ARE FURNISHED FOR INFORMATIONAL USE ONLY, AND ARE SUBJECT TO CHANGE AT ANY TIME WITHOUT NOTICE, AND SHOULD NOT BE CONSTRUED AS A COMMITMENT BY ASUS. ASUS ASSUMES NO RESPONSIBILITY OR LIABILITY FOR ANY ERRORS OR INACCURACIES THAT MAY APPEAR IN THIS MANUAL, INCLUDING THE PRODUCTS AND SOFTWARE DESCRIBED IN IT.

Copyright © 2023 ASUSTeK COMPUTER INC. All Rights Reserved.

LIMITATION OF LIABILITY

Circumstances may arise where because of a default on ASUS' part or other liability, you are entitled to recover damages from ASUS. In each such instance, regardless of the basis on which you are entitled to claim damages from ASUS, ASUS is liable for no more than damages for bodily injury (including death) and damage to real property and tangible personal property; or any other actual and direct damages resulted from omission or failure of performing legal duties under this Warranty Statement, up to the listed contract price of each product.

ASUS will only be responsible for or indemnify you for loss, damages or claims based in contract, tort or infringement under this Warranty Statement.

This limit also applies to ASUS' suppliers and its reseller. It is the maximum for which ASUS, its suppliers, and your reseller are collectively responsible.

UNDER NO CIRCUMSTANCES IS ASUS LIABLE FOR ANY OF THE FOLLOWING: (1) THIRD-PARTY CLAIMS AGAINST YOU FOR DAMAGES; (2) LOSS OF, OR DAMAGE TO, YOUR RECORDS OR DATA; OR (3) SPECIAL, INCIDENTAL, OR INDIRECT DAMAGES OR FOR ANY ECONOMIC CONSEQUENTIAL DAMAGES (INCLUDING LOST PROFITS OR SAVINGS), EVEN IF ASUS, ITS SUPPLIERS OR YOUR RESELLER IS INFORMED OF THEIR POSSIBILITY.

SERVICE AND SUPPORT

Visit our multi-language website at <https://www.asus.com/support/>

Table of Contents

Disclaimer	4
Safety precautions.....	4
Major components.....	6
Installation tools.....	7
Removing the compartment cover.....	8
Replacing the battery.....	14
Replacing the display panel module.....	17
Replacing the motherboard	26
Wiring and connection diagrams	37

Disclaimer

ASUS is not responsible for direct, indirect, intentional or unintentional damages resulting from improper installation and operation.

Safety precautions

- Keep liquids or moisture away from your Notebook PC before installing or removing any components.
- Ensure to place your Notebook PC on a stable surface before installing or removing any components.
- Detach the clip or flap before removing the signal cables to prevent damage.
- Disconnect the power plug by pulling the plug evenly to avoid damage. Ensure to connect the signal cables in the correct orientation.
- Disconnect all power cables and remove the battery pack (if applicable) before cleaning your Notebook PC with liquid detergent to avoid risk of electric shock.
- Disconnect all power cables and remove the battery pack (if applicable) before installing or removing any components. Ensure to read and follow the instructions in the manual.

- Before handling components, use a grounded wrist strap or touch a safely grounded object to avoid damaging them due to static electricity.
- Keep liquids or moisture away from your Notebook PC to avoid short circuits.
- Hold components by the edges to avoid touching the ICs.
- Ensure to properly install all the components before connecting the AC power.
- Do not use power adapters or batteries from other devices to reduce the risk of injury to persons due to fire or explosion. Use only certified power adapters or batteries supplied by the manufacturer or authorized retailers.
- Ensure to install the correct screw models on your Notebook PC to prevent damage.

Major components

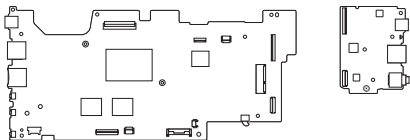

Motherboard with ports and connectors

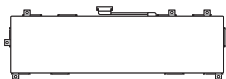

Battery and power connector

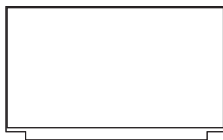

Display panel module

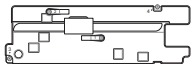

Thermal module

NOTE:

- The illustrations are for reference only.
 - The maintenance procedures described in this manual depend on the model configuration and may not reflect the entire servicing process. For servicing those components that are not covered in this manual, please visit an authorized service center for further assistance.
-

Installation tools



Screwdriver



Plastic blade



Tweezers

Removing the compartment cover

NOTE: The appearance of your Notebook PC's bottom view may vary per model.

- A. Loosen the pop-open screw(s) without removing the screw(s) from the Notebook PC's bottom cover.

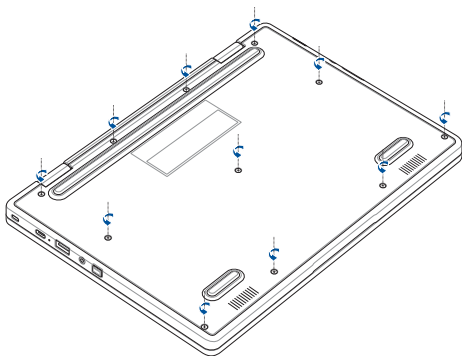

- B. Place your Notebook PC in the orientation shown in the illustration below.
- C. Use the plastic blade to pry open the indicated area of the compartment cover as shown in the illustration below.

IMPORTANT! Avoid sliding the plastic blade along the side of your Notebook PC to prevent damage.

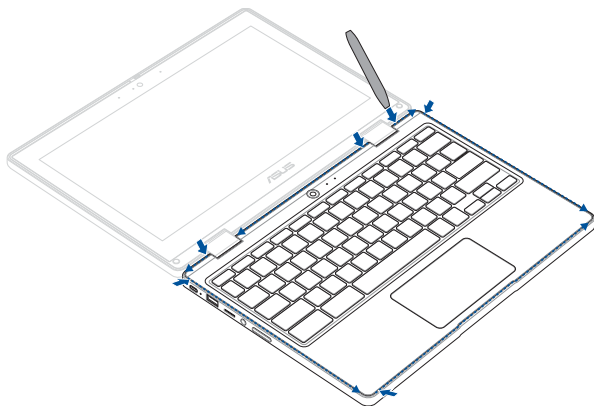

- D. Lift the compartment cover without removing it completely, then hold it in place above the chassis.

IMPORTANT! Lift the compartment cover carefully to avoid damaging the connected cable(s) or connector(s).

- E. Locate and disconnect the battery power cable.
F. Disconnect the cable(s) as shown in the illustration below.
G. Remove the compartment cover.

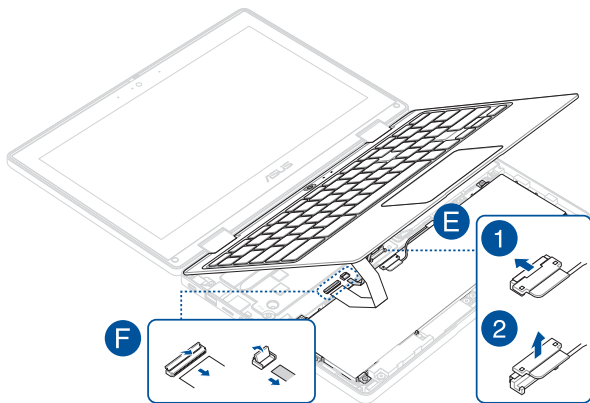

To reattach the compartment cover:

- A. Align the compartment cover with the chassis, then hold it in place above the chassis.
- B. Reconnect the cable(s) as shown in the illustration below.
- C. Reconnect the battery power cable.
- D. Lower the compartment cover into place.

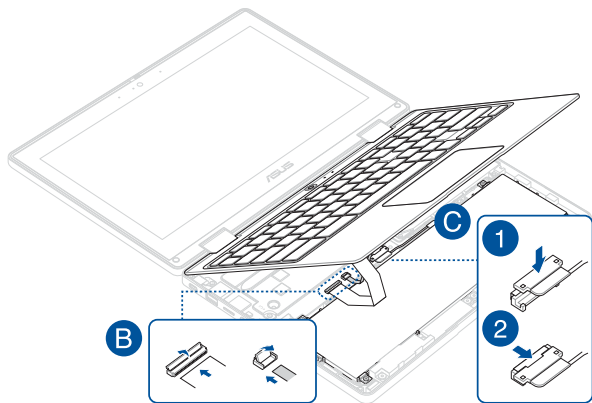

- E. Reattach the compartment cover to the chassis.

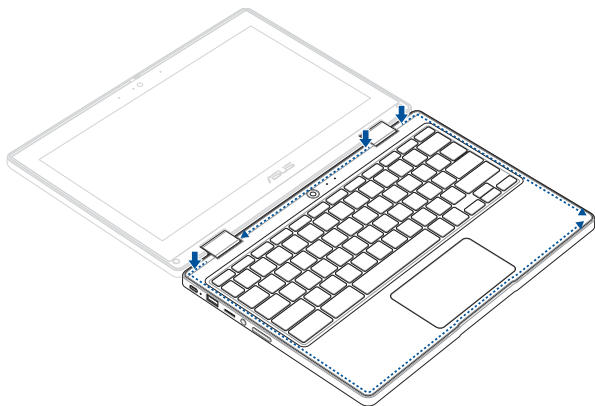

- F. Place your Notebook PC in the orientation shown in the illustration below.
- G. Secure the bottom cover by tightening the pop-open screw(s).

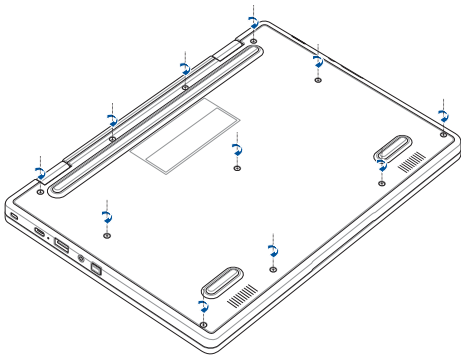

Replacing the battery

Refer to the following steps when installing a compatible battery in your Notebook PC:

IMPORTANT! Purchase your battery from authorized retailers of this Notebook PC to ensure maximum compatibility and reliability.

WARNING! Disconnect all the connected peripherals, any telephone or telecommunication lines and power connector (such as external power supply, battery pack, etc.) before removing the compartment cover.

NOTE:

- The appearance of your Notebook PC's bottom view and battery may vary per model but the module installation remains the same.
 - It is recommended that you install the battery under professional supervision. You may also visit an authorized service center for further assistance.
-

- A. Remove the compartment cover and disconnect the battery.

NOTE: For more details, refer to the *Removing the compartment cover* section in this manual.

- B. Remove the screw(s) from the battery.

- C. Remove the battery.

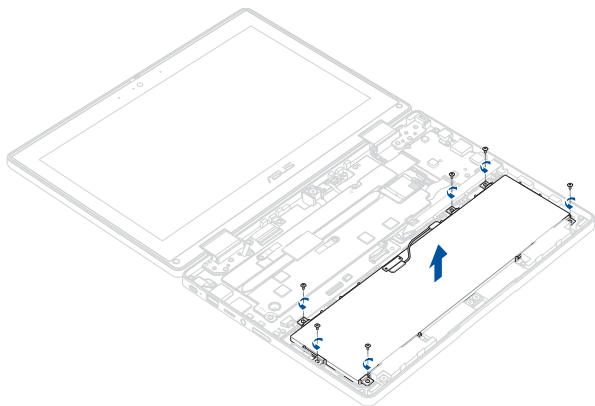

To install the battery:

- A. Prepare the battery.
- B. Align and reinstall the battery.
- C. Secure the battery using the screw(s) you removed earlier.
- D. Reattach the compartment cover.

NOTE: For more details, refer to the *Removing the compartment cover* section in this manual.

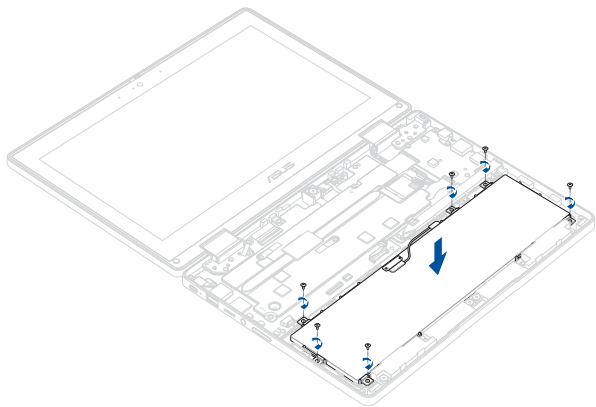

Replacing the display panel module

IMPORTANT! Do not bend the display panel in any way to avoid risk of display panel leakage.

NOTE: The illustrations are for reference only.

- A. Remove the compartment cover and disconnect the battery.
-

NOTE: For more details, refer to the *Removing the compartment cover* section in this manual.

- B. Remove the thermal module screw(s) one by one in the sequence shown in the illustration below.
- C. Remove the thermal module from the motherboard.

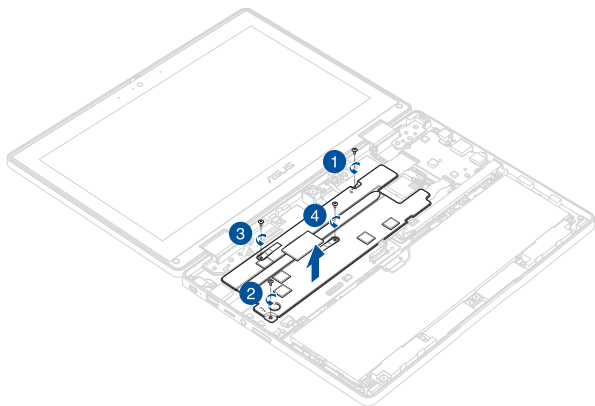

- D. Disconnect the cable(s) as shown in the illustration below.

IMPORTANT! Hold the cable with both hands to avoid bending the cable.

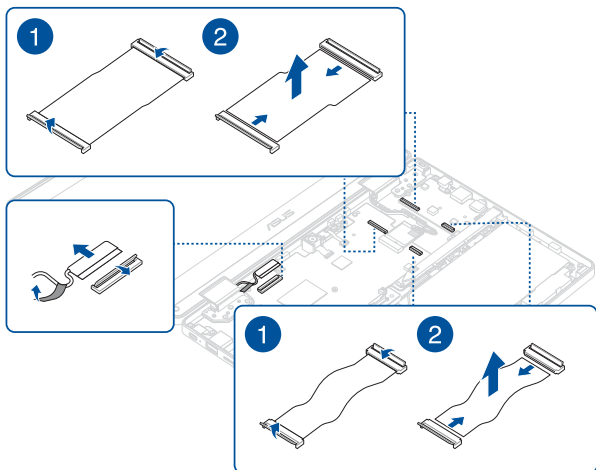

- E. Locate and disconnect the antenna cable(s).
- F. Remove the screw, then remove the Wi-Fi module.
- G. Remove the antenna cable(s) from the cable guide

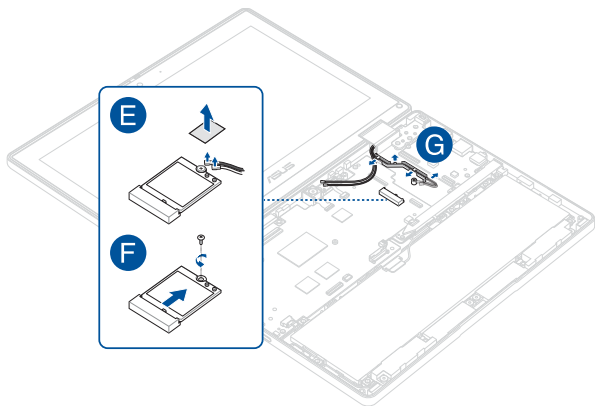

- H. Place your Notebook PC in the orientation shown in the illustration below.
- I. Remove the screw(s) from the hinges.
- J. Remove the display panel module.

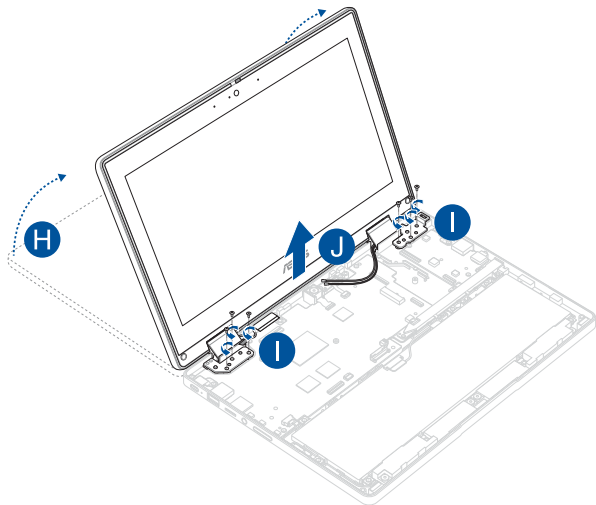

To install the display panel module:

- A. In the orientation shown, align and place the hinges of the display panel module on the screw holes of the chassis.
- B. Secure the hinges using the screw(s) you removed earlier.

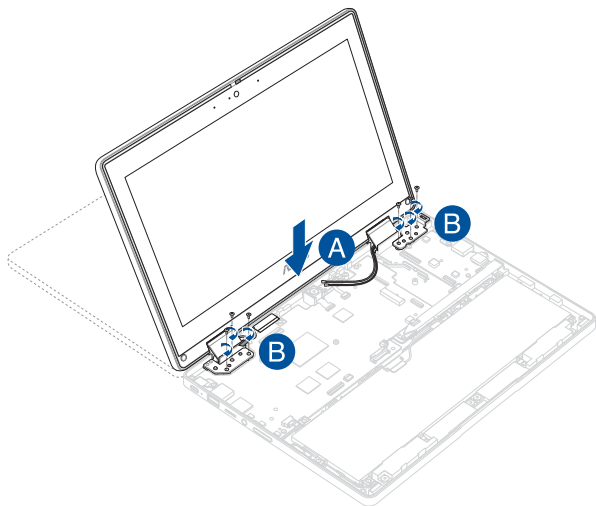

- C. Route the antenna cables through the cable guides.
- D. Align and reinstall the Wi-Fi module, then secure the Wi-Fi module using the screw you removed earlier.
- E. Reconnect the antenna cable(s).

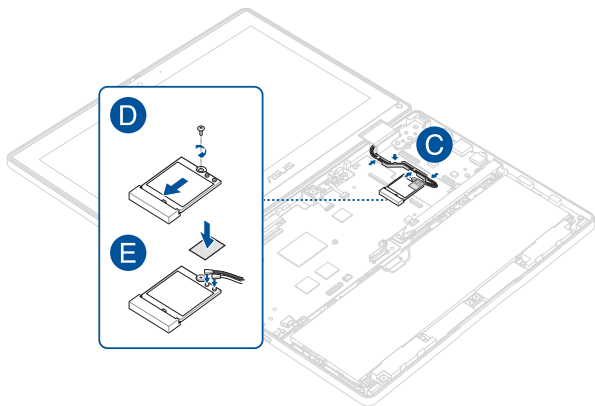

- F. Reconnect the cable(s) as shown in the illustration below.

IMPORTANT! Hold the cable with both hands to avoid bending the cable.

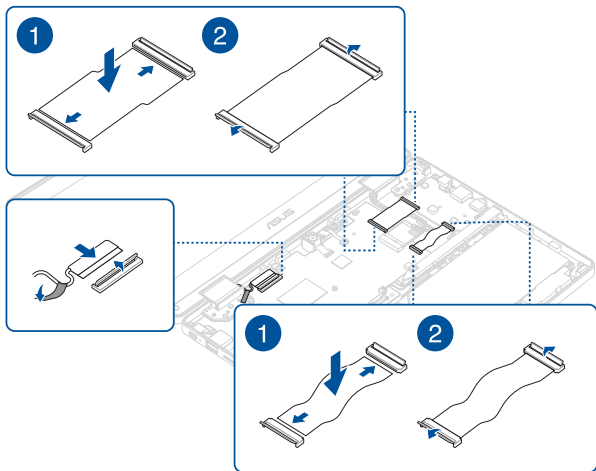

- G. Align and place the thermal module on the screw holes of the motherboard.
- H. Secure the thermal module screw(s) one by one in the sequence shown in the illustration below.

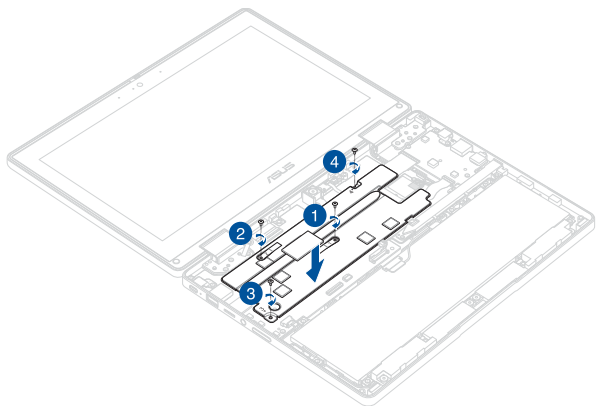

Replacing the motherboard

Refer to the following steps when installing the motherboard to your Notebook PC:

IMPORTANT! Purchase your motherboard from authorized retailers of this Notebook PC to ensure maximum compatibility and reliability.

WARNING! Disconnect all the connected peripherals, any telephone or telecommunication lines and power connector (such as external power supply, battery pack, etc.) before removing the compartment cover.

NOTE:

- The appearance of your Notebook PC's bottom view and motherboard may vary per model but the module installation remains the same.
 - It is recommended that you install the motherboard under professional supervision. You may also visit an authorized service center for further assistance.
-

A. Remove the compartment cover and disconnect the battery.

NOTE: For more details, refer to the *Removing the compartment cover* section in this manual.

- B. Remove the thermal module screw(s) one by one in the sequence shown in the illustration below.
- C. Remove the thermal module from the motherboard.

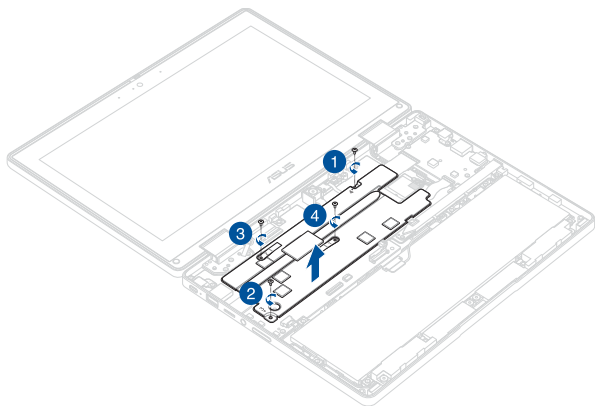

- D. Disconnect the cable(s) as shown in the illustration below.

IMPORTANT! Hold the cable with both hands to avoid bending the cable.

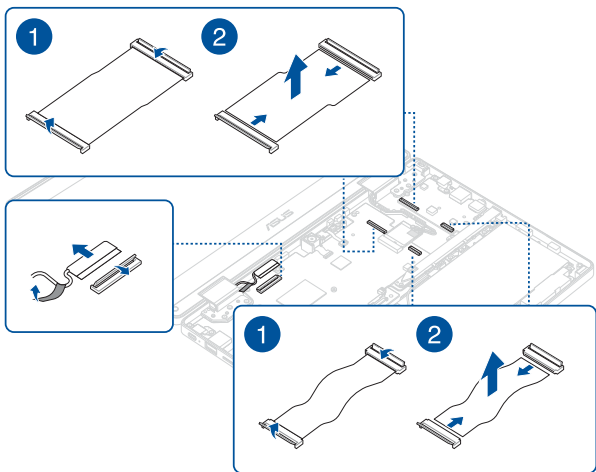

- E. Locate and disconnect the antenna cable(s).
- F. Remove the screw, then remove the Wi-Fi module.
- G. Remove the antenna cable(s) from the cable guide

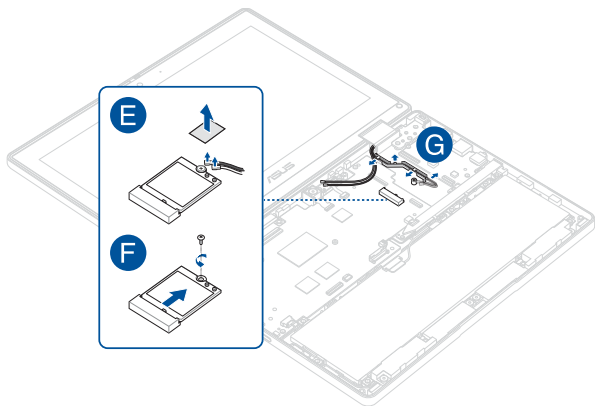

H. Disconnect the cable(s) as shown in the illustration below.

CR1102CGA

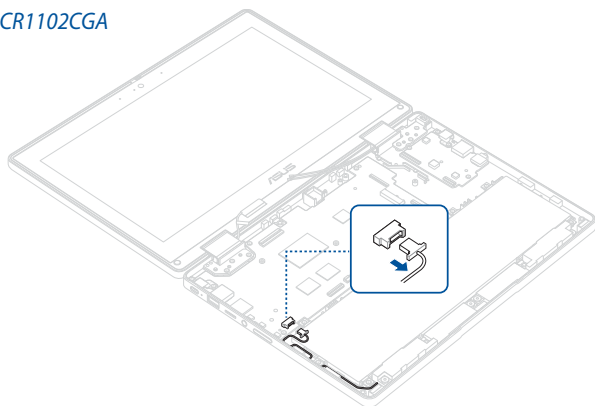

CR1102FGA

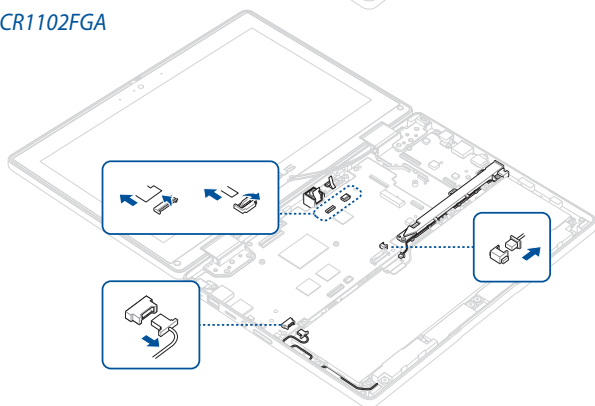

- I. Remove the screw(s).
- J. Remove the bracket.
- K. Remove the motherboard from the chassis.

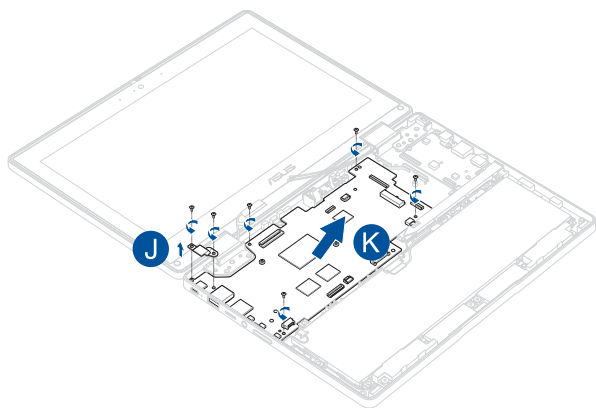

To install the motherboard:

- A. Prepare the motherboard.
- B. Align and place the motherboard in the chassis.
- C. Secure the bracket using the screw(s) you removed earlier.
- D. Secure the motherboard using the screw(s) you removed earlier.

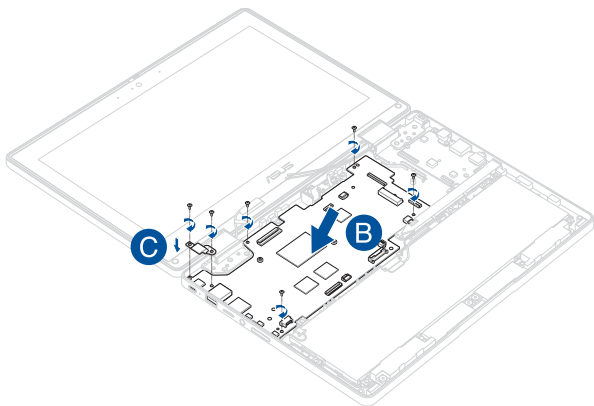

E. Reconnect the cable(s) as shown in the illustration below.

CR1102CGA

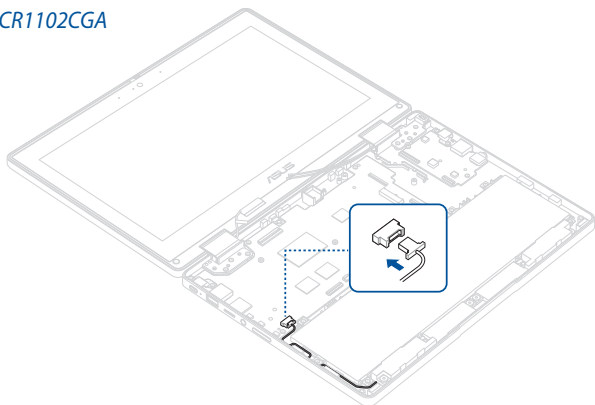

CR1102FGA

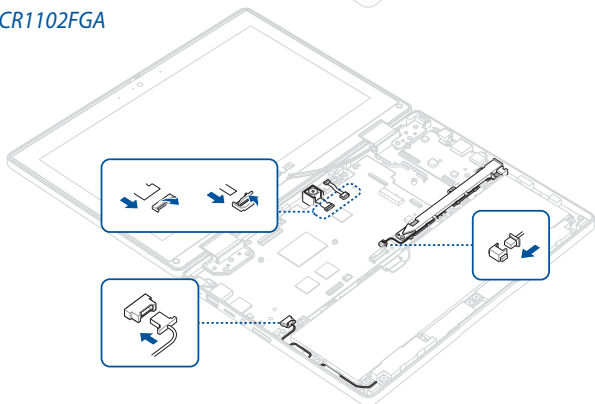

- F. Route the antenna cables through the cable guides.
- G. Align and reinstall the Wi-Fi module, then secure the Wi-Fi module using the screw you removed earlier.
- H. Reconnect the antenna cable(s).

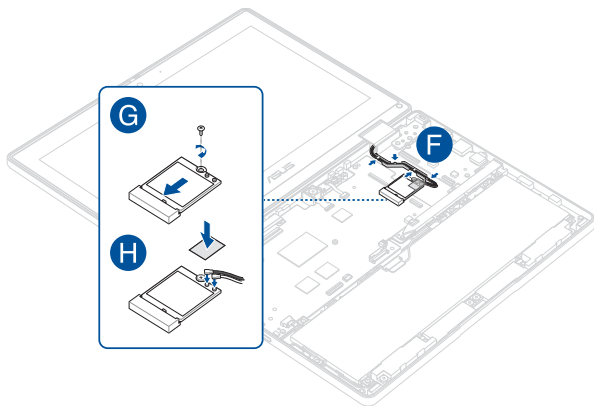

- I. Reconnect the cable(s) as shown in the illustration below.

IMPORTANT! Hold the cable with both hands to avoid bending the cable.

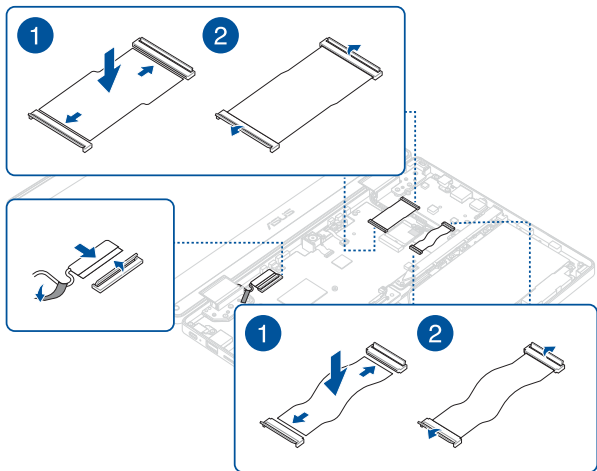

- J. Align and place the thermal module on the screw holes of the motherboard.
- K. Secure the thermal module screw(s) one by one in the sequence shown in the illustration below.

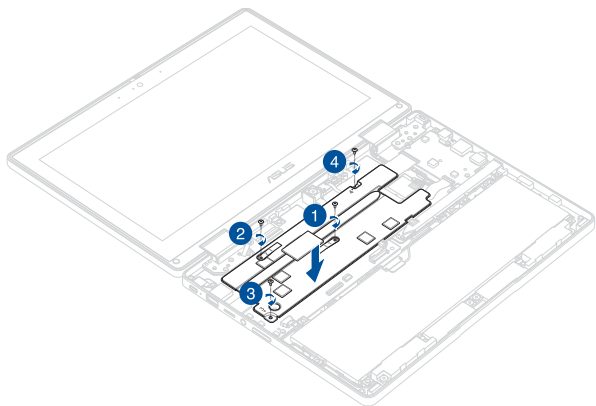

Wiring and connection diagrams

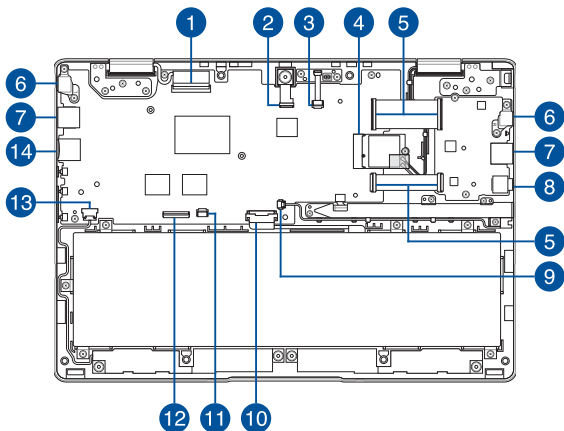

Top View

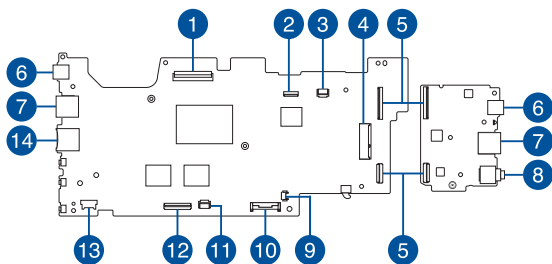

Bottom View

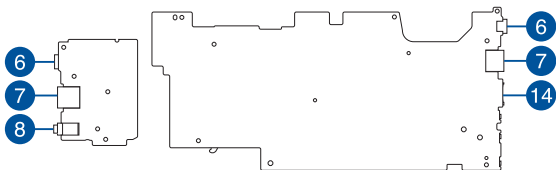

- | | |
|----------------------------|------------------------------|
| 1. eDP connector | 8. Audio connector |
| 2. Camera connector* | 9. Stylus charger connector* |
| 3. Microphone connector* | 10. Battery connector |
| 4. Wi-Fi module connector | 11. Touchpad connector |
| 5. I/O board FFC connector | 12. Keyboard connector |
| 6. USB Type-C® connector | 13. Speaker connector |
| 7. USB Type-A connector | 14. MicroSD card slot |

*On selected models