

1442535F3-AO

ADTRAN® 1442535F3 Compatible TAA GPON ONU 1.2Gbs/2.4Gbs SFP Transceiver (SMF, 1310nmTx/1490nmRx, 20km, ASC, -40 to 85C)

Features

- SC Connector
- Industrial Temperature -40 to 85 Celsius
- Single-mode Fiber
- Hot Pluggable
- Excellent ESD Protection
- Metal with Lower EMI
- RoHS Compliant and Lead Free



Applications

- GPON
- Access and Enterprise

Product Description

This ADTRAN® 1442535F3 compatible SFP transceiver provides 2.4Gbs/1.2Gbs-B+ throughput up to 20km over single-mode fiber (SMF) using a wavelength of 1310nmTx/1490nmRx via an ASC connector. It is guaranteed to be 100% compatible with the equivalent ADTRAN® transceiver. This easy to install, hot swappable transceiver has been programmed, uniquely serialized and data-traffic and application tested to ensure that it will initialize and perform identically. It is built to meet or exceed the specifications of ADTRAN®, as well as to comply with MSA (Multi-Source Agreement) standards to ensure seamless network integration. This transceiver is Trade Agreements Act (TAA) compliant. We stand behind the quality of our products and proudly offer a limited lifetime warranty.

AddOn's transceivers are RoHS compliant and lead-free.

TAA refers to the Trade Agreements Act (19 U.S.C. & 2501-2581), which is intended to foster fair and open international trade. TAA requires that the U.S. Government may acquire only "U.S. – made or designated country end products."



Absolute Maximum Ratings

Parameter	Symbol	Min.	Typ.	Max.	Unit	Notes
Maximum Supply Voltage	V _{cc}	0		3.6	V	1
Storage Ambient Temperature	T _{stg}	-40		+85	°C	1
Relative Humidity - Storage	RH _s	0		95	%	1
Operating Case Temperature	T _{CASE}	-40	25	85	°C	1
Relative Humidity - Operating	RH _o	0		85	%	1
Downstream Signaling Speed +/- 100 ppm	S _{down}		2488		Mb/s	
Upstream Signaling Speed +/- 100 ppm	S _{up}		1244		Mb/s	
Control Function Logic Levels						
Transmit Burst Enable Logic HIGH State	Tx_Burst	0		V _{cc} +0.5	V	LVTTTL
Transmit FAULT Logic HIGH State	Tx_Fault	0		V _{cc} +0.5	V	2
Receiver Loss of Signal High Logic	Rx_Los	0		V _{cc} +0.5	V	LVTTTL
I ² C Serial Data Logic HIGH State	SDA	-		V _{cc} +0.5	V	LVTTTL
I ² C Serial Clock HIGH State	SCL	-		V _{cc} +0.5	V	LVTTTL

Notes:

1. Exceeding the Absolute Maximum Ratings may cause irreversible damage to the device. The device is not intended to be operated under the condition of simultaneous Absolute Maximum Ratings, a condition which may cause irreversible damage to the unit.
2. LVTTTL (Laser is OFF / FAULT)

Electrical Characteristics

Parameter	Symbol	Min.	Typ.	Max.	Unit	Notes
Module Supply Voltage	VCC	3.135	3.3	3.465	V	
Module Supply Current	IIN			400	mA	
Transmitter						
Tx_Data Differential Input Voltage	VIN	400		1600	mV	1
Tx_Burst = HIGH (Transmitter OFF / DISABLED)	VIH	2.0		V _{CC} +0.3	V	2, 3
Tx_Burst = LOW (Transmitter ON / ENABLED)	VIL	0		0.8	V	2, 3
Tx_FAULT = HIGH (FAULT Condition)	VOH	V _{CC} - 0.5		V _{CC} +0.3	V	4
Tx_FAULT = LOW (NORMAL)	VOL	0		0.8	V	4
Tx_SD = HIGH (Transmitter ON)	VIH	2.0		V _{CC} +0.3	V	
Tx_SD= LOW (Transmitter OFF)	VIL	0		0.8	V	
Receiver						
Rx_Data Differential Output Voltage	VOUT	200		1600	mV	5
Rx_Los = LOW (Receiver ON / NORMAL)	VOH	0		0.8	V	
Rx_Los = HIGH (Receiver OFF / Loss of Signal)	VOL	V _{CC} -0.5		V _{CC} +0.3	V	

Notes:

1. LVPECL Tx_DATA Electrical Signal
2. LVTTTL (Control INPUT)
3. Transmitter Enable Control Level can be chosen, High Enable and Low enable are compatible.
4. LVTTTL (Monitor OUTPUT)
5. CML Rx_DATA Electrical Signal

Optical Characteristics

Parameter	Symbol	Min.	Typ.	Max.	Unit	Notes
Transmitter						
Transmitter Type		1310nm DFB Burst Mode				
Transmitter Control		Burst Mode ON/OFF				1
Upstream Signaling Speed	Sup		1244		Mb/s	
Average Output Power (9/125 μ m SMF)	P _{out}	0.5		5	dBm	
Optical Output with Tx OFF	POFF			-45	dBm	
Optical Center Wavelength	λ	1290	1310	1330	nm	
Spectral Line Width @ -20 dB	$\Delta\lambda$			1.0	nm	
Side Mode Suppression Ratio	SMSR	30			dB	
Extinction Ratio	ER	10			dB	
Transmitter Turn ON / Turn OFF Time	t _{ON} / t _{OFF}			12.8	ns	
Peak to Peak Jitter	JP-P			0.2	UI	
Receiver						
Receiver Type		1490nm CW Mode				
Optical Signal Monitor		Loss of Signal				2
Optical Center Wavelength	λ	1480	1490	1500	nm	
Downstream Signaling Speed	S _{down}		2488		Mb/s	
Receiver Sensitivity	P _{iN}			-28	dBm	3
Receiver Optical Overload	P _{IN(SAT)}	-8			dBm	3
Rx_Los Assert	P _a	-45			dBm	
Rx_Los Deassert	P _d			-28.5	dBm	
Optical Isolation from External Source	ISO	25			dB	

Notes:

1. Tx_Burst = Burst Mode Control
2. Rx_Los Monitors Rx ON / OFF state
3. BER < 10⁻¹⁰, 2488 Mb/s, PRBS 2²³- 1

Pin Description

PIN	Symbol	Name / Description	Notes
1	VEET	Transmitter Ground	
2	Tx_FAULT	Transmitter Fault, LOW = Normal Operation, HIGH = Fault Indication	1
3	Tx_DIS	Transmit Disable, LOW = Normal Operation, HIGH = Disables Module	1
4	MOD_DEF 2	Module Definition 2 - Two-Wire Interface - Serial Data	1
5	MOD_DEF 1	Module Definition 1 - Two-Wire Interface - Clock Signal	1
6	MOD_DEF 0	Module Definition 0 - Presence Pin, the MOD_DEF0 Signal set to low level after initialization of μ C and power up the I2C interface	
7	Dying Gasp	Dying Gasp Indication, when high indicates normal operation, low indicates power fail	4
8	LOS	Loss of Signal, When high indicates no optical power; Low indicates normal operation	1
9	VEER	Receiver Ground	
10	VEER	Receiver Ground	
11	VEER	Receiver Ground	
12	RD-	Rx_Data Output (Inverted)	2
13	RD+	Rx_Data Output (Non Inverted)	2
14	VEER	Receiver Ground	
15	VCCR	Receiver DC Power	3.3 V +/- 5%
16	VCCT	Transmitter DC Power	3.3 V +/- 5%
17	VEET	Transmitter Ground	
18	TD+	Tx_Data Input (Non Inverted)	3
19	TD-	Tx_Data Input (Inverted)	3
20	VEET	Transmitter Ground	

Notes:

1. The uncommitted Tx_FAULT, Tx_DIS, MOD_DEF2 ,MOD_DEF1 and LOS monitor and control pins each require a pull up resistor of 4.7k to 10k Ohms. The pull-up voltage must be 3.3V.
2. The 100Ohms differential Rx Data output is internally AC coupled. Supporting both 1000BASE-X/SGMII interface
3. The 100Ohms differential Tx Data input is internally AC coupled. Supporting both 1000BASE-X/SGMII interface
4. Voltage Detect Input for Dying Gasp. When the voltage on this pin is lower than 1.23V+/-5%, a dying gasp event is triggered. A 4.7k Ohm resistor is used to pull up to DC Power in the module.

TOP VIEW
OF BOARD

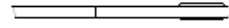
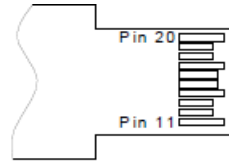

BOTTOM VIEW
OF BOARD

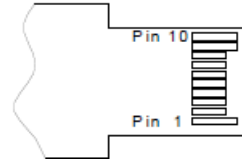

Pin-out of connector Block on Host board

WBF Isolation Characteristics

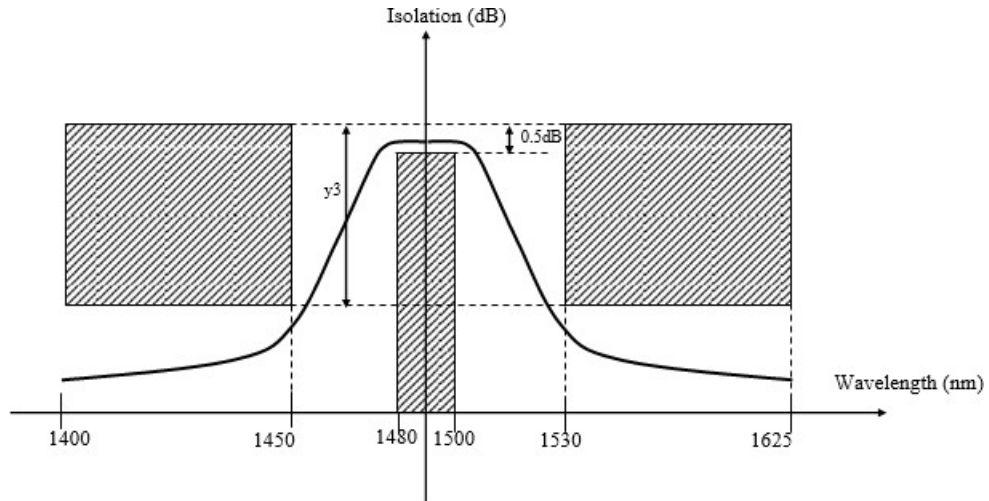

WBF Isolation Characteristics				
Wavelength (nm)	1400~1441	1450	1530	1539~1625
Isolation (dB)	y_3	y_3	y_3	y_3
	>35	>25	>25	>35

Timing Diagram

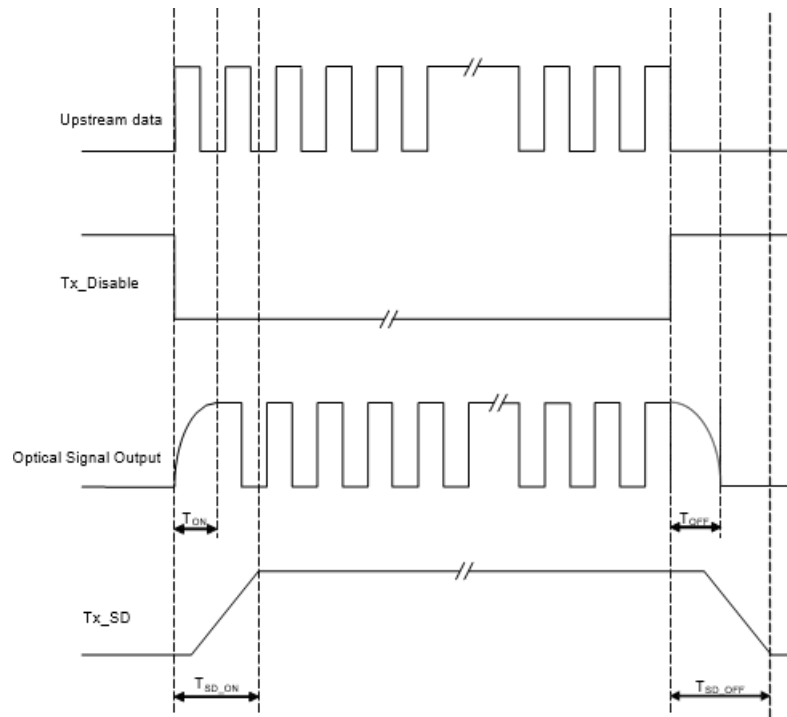

Timing Diagram Characteristics

Parameter	Symbol	Min	Typ	Max	Units
Transmitter Turn ON Time	T_{ON}			12.8	ns
Transmitter Turn OFF Time	T_{OFF}			12.8	ns
Tx_SD Assert Time	T_{SD_ON}			350	ns
Tx_SD Deassert Time	T_{SD_OFF}			350	ns

Electrical Interface

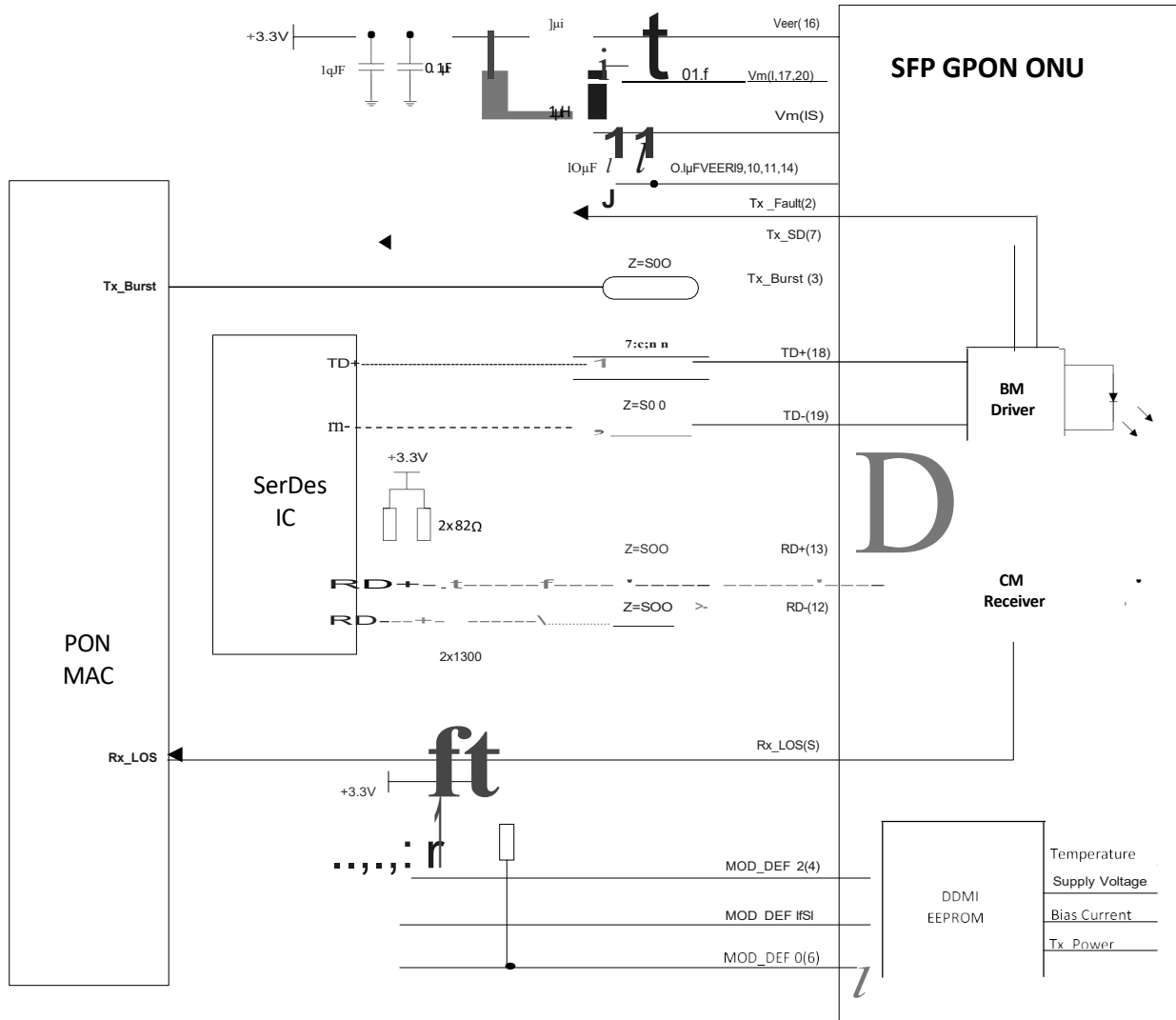

Mechanical Specifications

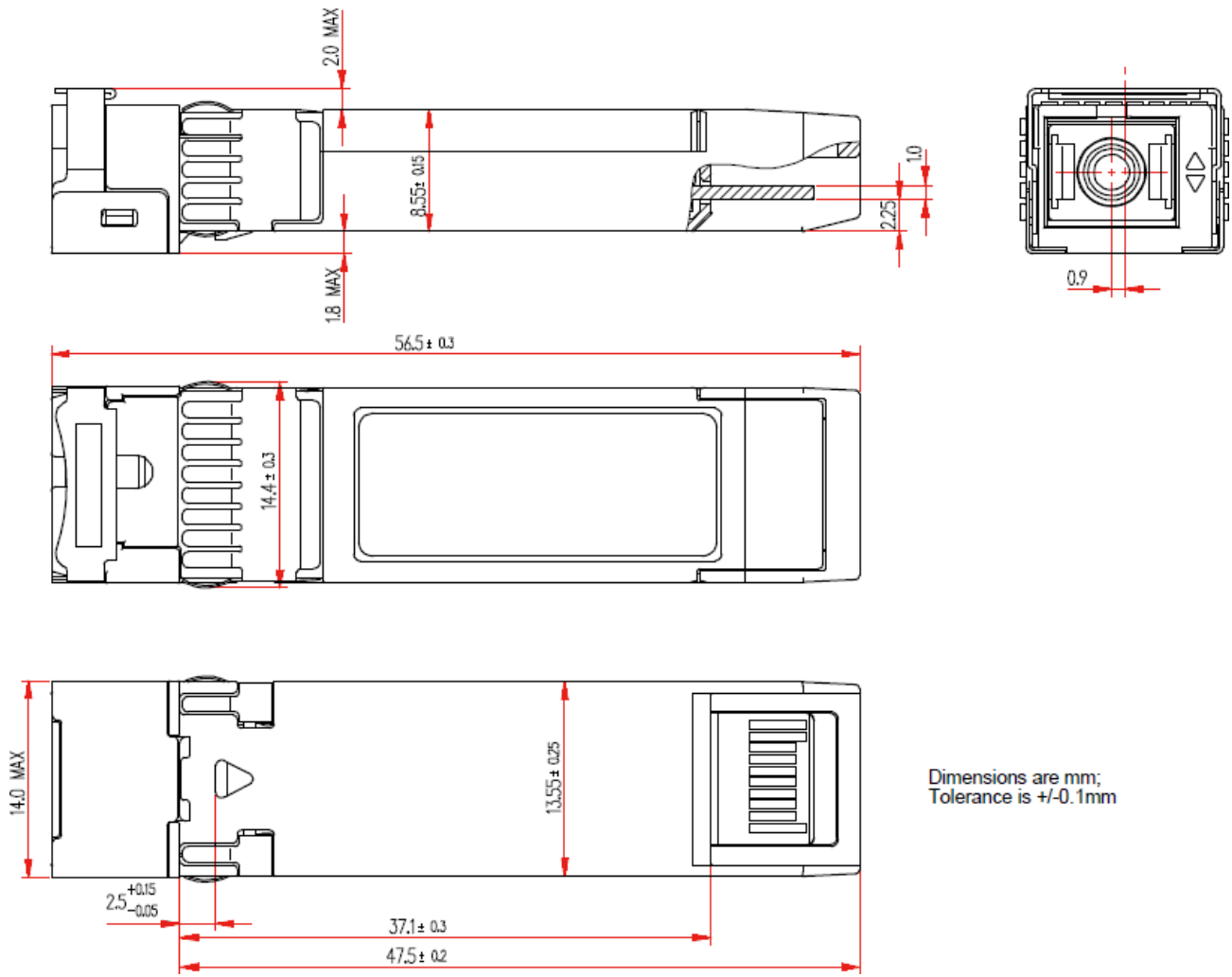

Dimensions are mm;
Tolerance is +/-0.1mm

About AddOn Networks

In 1999, AddOn Networks entered the market with a single product. Our founders fulfilled a severe shortage for compatible, cost-effective optical transceivers that compete at the same performance levels as leading OEM manufacturers. Adhering to the idea of redefining service and product quality not previously had in the fiber optic networking industry, AddOn invested resources in solution design, production, fulfillment, and global support.

Combining one of the most extensive and stringent testing processes in the industry, an exceptional free tech support center, and a consistent roll-out of innovative technologies, AddOn has continually set industry standards of quality and reliability throughout its history.

Reliability is the cornerstone of any optical fiber network and is engrained in AddOn's DNA. It has played a key role in nurturing the long-term relationships developed over the years with customers. AddOn remains committed to exceeding industry standards with certifications from ranging from NEBS Level 3 to ISO 9001:2005 with every new development while maintaining the signature reliability of its products.



U.S. Headquarters

Email: sales@addonnetworks.com

Telephone: +1 877.292.1701

Fax: 949.266.9273

Europe Headquarters

Email: salesupportemea@addonnetworks.com

Telephone: +44 1285 842070