

MMA1T00-VS-AO

Mellanox® MMA1T00-VS Compatible 200GBase-SR4 QSFP56 Transceiver (MMF, 850nm, 100m, MPO, DOM)

Features

- Supports SFF-8636 management interface
- Multi-mode Fiber
- MPO Connector
- Hot Pluggable
- Metal with Lower EMI
- Commercial Temperature 0 to 70 Celsius
- RoHS Compliant and Lead-Free
- Excellent ESD Protection

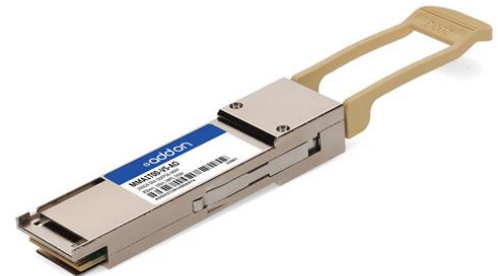

Applications

- Ethernet
- 200GBase
- Access and Enterprise

Product Description

This Mellanox® QSFP56 transceiver provides 200GBase-SR4 throughput up to 100m over multi-mode fiber (MMF) using a wavelength of 850nm via an MPO connector. It is guaranteed to be 100% compatible with the equivalent Mellanox® transceiver. This easy to install, hot swappable transceiver has been programmed, uniquely serialized and data-traffic and application tested to ensure that it will initialize and perform identically. Digital optical monitoring (DOM) support is also present to allow access to real-time operating parameters. This transceiver is Trade Agreements Act (TAA) compliant. We stand behind the quality of our products and proudly offer a limited lifetime warranty.

AddOn's transceivers are RoHS compliant and lead-free.

TAA refers to the Trade Agreements Act (19 U.S.C. & 2501-2581), which is intended to foster fair and open international trade. TAA requires that the U.S. Government may acquire only "U.S. – made or designated country end products."



Absolute Maximum Ratings

Parameter	Symbol	Min.	Typ.	Max.	Unit	Notes
Maximum Supply Voltage	V _{cc}	0		3.63	V	
Storage Temperature	T _{stg}	-40		85	°C	
Relative Humidity	RH	5		85	%	1
Operating Case Temperature	T _c	0		70	°C	
Bit Error Ratio	BER			2.4E-4		2

Notes:

1. Non-condensing.
2. The typical BER is better than 1E-6 when measured with a transmitter to produce SECCQ up to 3dB.

Electrical Characteristics

Parameter	Symbol	Min.	Typ.	Max.	Unit	Notes
Module Supply Voltage	V _{cc}	3.135	3.3	3.465	V	
Module Supply Current	I _{cc}			1600	mA	
Module Power Dissipation	P _D			5	W	
Transmitter						
Differential Data Input Voltage Peak-to-Peak Swing	V _{IN,pp}			900	mV	
Receiver						
Differential Data Output Voltage Peak-to-Peak Swing	V _{OUT,pp}			900	mV	

Optical Characteristics

Parameter	Symbol	Min.	Typ.	Max.	Unit	Notes
Transmitter						
Signaling Rate Per Lane	Rate		26.5625		GBd	
Modulation Format	MF		PAM4			
Signaling Speed Accuracy	SSA	-100		100	ppm	
Center Wavelength	λ		850		nm	
RMS Spectral Width	$\Delta\lambda$			0.6	nm	
Optical Return Loss Tolerance	ORLT			12	dB	
Average Optical Power	Pavg	-6.5		+4	dBm	
Extinction Ratio	ER	3			dB	
Optical Modulation Amplitude Per Lane	OMA	-4.5		+3	dBm	
Launch Power in OMA Outer Minus TDECQ Per Lane		-5.9			dBm	
Transmitter and Dispersion Eye Closure for PAM4 (TDECQ) Per Lane	TDECQ			4.5	dB	
TDECQ – 10*log ₁₀ (Ceq) Per Lane				4.5	dB	
Relative Intensity Noise	RIN			-128	dB/Hz	
Transmitter Transition Time Per Lane				34	ps	
Laser Off Power				-30	dBm	
Encircled Flux	EF		≥86% at 19μm ≤ 30% at 4.5μm			
Receiver						
Signaling Rate Per Lane	Rate		26.5625		GBd	
Modulation Format	MF		PAM4			
Signaling Speed Accuracy	SSA	-100		+100	ppm	
Center Wavelength	λ		850		nm	
Average Receive Power Per Lane	Pavg	-8.4		+4	dBm	
Receive Power Per Lane OMA	Po			3	dBm	
Receiver Reflectance	RL			-12	dB	
Receiver Sensitivity OMA Per Lane	S			Max = (-6.5, SECQ-7.9)	dBm	1
Damage Threshold	THd	5			dBm	

Notes:

1. Receiver sensitivity is informative and defined for a transmitter with a value of SECQ up to 4.5dB.

Pin Descriptions

Pin	Symbol	Description	Notes
1	GND	Ground.	1
2	Tx2-	Transmitter Inverted Data Input.	
3	Tx2+	Transmitter Non-Inverted Data Input.	
4	GND	Ground.	1
5	Tx4-	Transmitter Inverted Data Input.	
6	Tx4+	Transmitter Non-Inverted Data Input.	
7	GND	Ground.	
8	ModSelL	Module Select.	
9	ResetL	Module Reset.	
10	VccRx	+3.3V Power Supply Receiver.	2
11	SCL	2-Wire Serial Interface Clock.	
12	SDA	2-Wire Serial Interface Data.	
13	GND	Ground.	
14	Rx3+	Receiver Non-Inverted Data Output.	
15	Rx3-	Receiver Inverted Data Output.	
16	GND	Ground.	1
17	Rx1+	Receiver Non-Inverted Data Output.	
18	Rx1-	Receiver Inverted Data Output.	1
19	GND	Ground.	1
20	GND	Ground.	
21	Rx2-	Receiver Inverted Data Output.	
22	Rx2+	Receiver Non-Inverted Data Output.	
23	GND	Ground.	
24	Rx4-	Receiver Inverted Data Output.	
25	Rx4+	Receiver Non-Inverted Data Output.	
26	GND	Ground.	1
27	ModPrsL	Module Present.	
28	IntL/RxLOSL	Interrupt. Optionally configurable as RxLOSL via the management interface (SFF-8636).	
29	VccTx	+3.3V Power Supply Transmitter.	2
30	Vcc1	+3.3V Power Supply.	2
31	LPMode/TxDis	Low-Power Mode. Optionally configurable as TxDis via the management interface (SFF-8636).	
32	GND	Ground.	1
33	Tx3+	Transmitter Non-Inverted Data Input.	
34	Tx3-	Transmitter Inverted Data Input.	
35	GND	Ground.	1
36	Tx1+	Transmitter Non-Inverted Data Input.	
37	Tx1-	Transmitter Inverted Data Input.	
38	GND	Ground.	1

Notes:

1. GND is the symbol for signal and supply (power) common for the module. All are common within the module and all module voltages are referenced to this potential unless otherwise noted. Connect these directly to the host board signal-common ground plane.
2. VccRx, Vcc1, and VccTx are applied concurrently and may be internally connected within the module in any combination.

Block Diagram of Transceiver

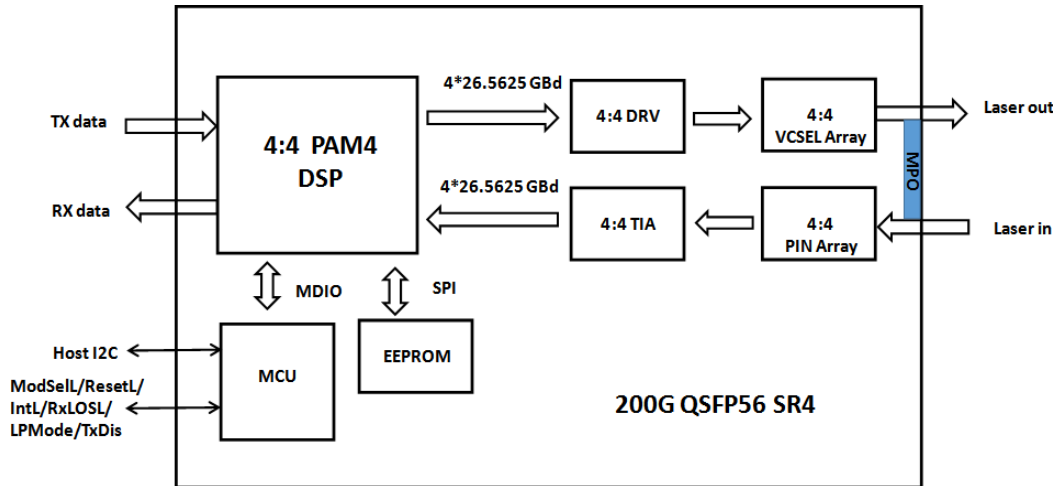

Transmitter Section: This module converts 4-channel 53.125Gbps electrical data to 4-channel 850nm 53.125Gbps optical signals for 212Gbps optical transmission.

Receiver Section: Similarly, this module optically converts 4-channel 850nm 53.125Gbps optical signals to 4-channel electrical data output on the receiver side.

Recommended Interface Circuit

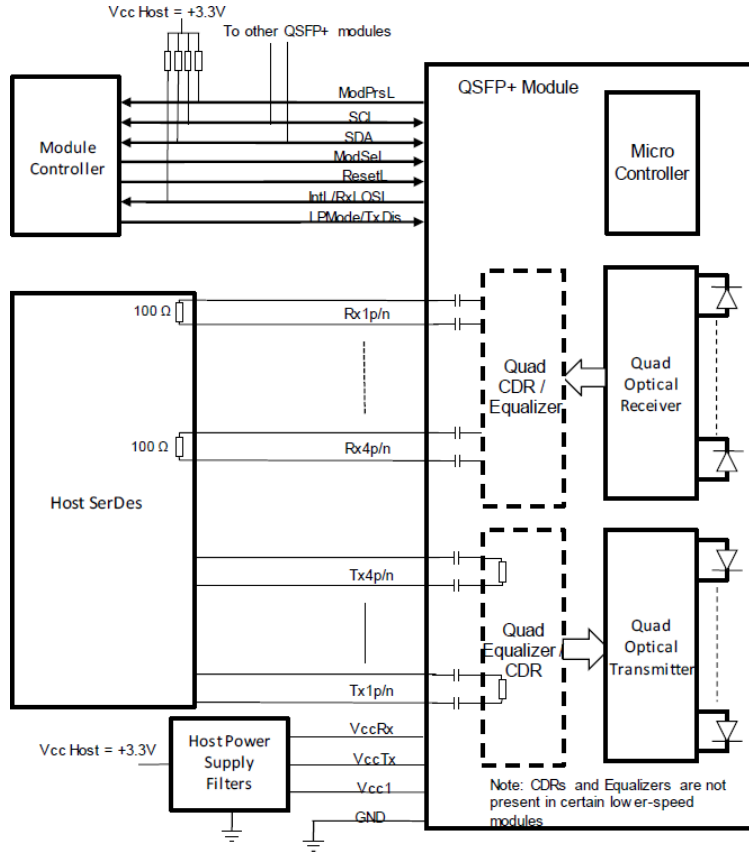

Mechanical Specifications

Unit is millimeter. All dimensions are $\pm 0.1\text{mm}$ unless otherwise specified.

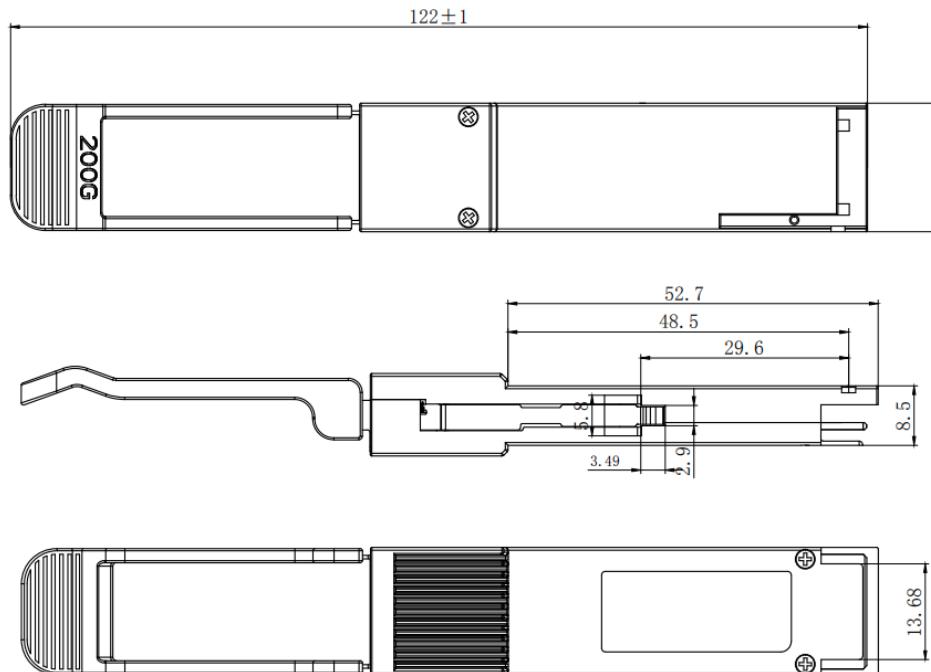

About AddOn Networks

In 1999, AddOn Networks entered the market with a single product. Our founders fulfilled a severe shortage for compatible, cost-effective optical transceivers that compete at the same performance levels as leading OEM manufacturers. Adhering to the idea of redefining service and product quality not previously had in the fiber optic networking industry, AddOn invested resources in solution design, production, fulfillment, and global support.

Combining one of the most extensive and stringent testing processes in the industry, an exceptional free tech support center, and a consistent roll-out of innovative technologies, AddOn has continually set industry standards of quality and reliability throughout its history.

Reliability is the cornerstone of any optical fiber network and is engrained in AddOn's DNA. It has played a key role in nurturing the long-term relationships developed over the years with customers. AddOn remains committed to exceeding industry standards with certifications from ranging from NEBS Level 3 to ISO 9001:2005 with every new development while maintaining the signature reliability of its products.



U.S. Headquarters

Email: sales@addonnetworks.com

Telephone: +1 877.292.1701

Fax: 949.266.9273

Europe Headquarters

Email: salesupportemea@addonnetworks.com

Telephone: +44 1285 842070