

 MONOPRICE™

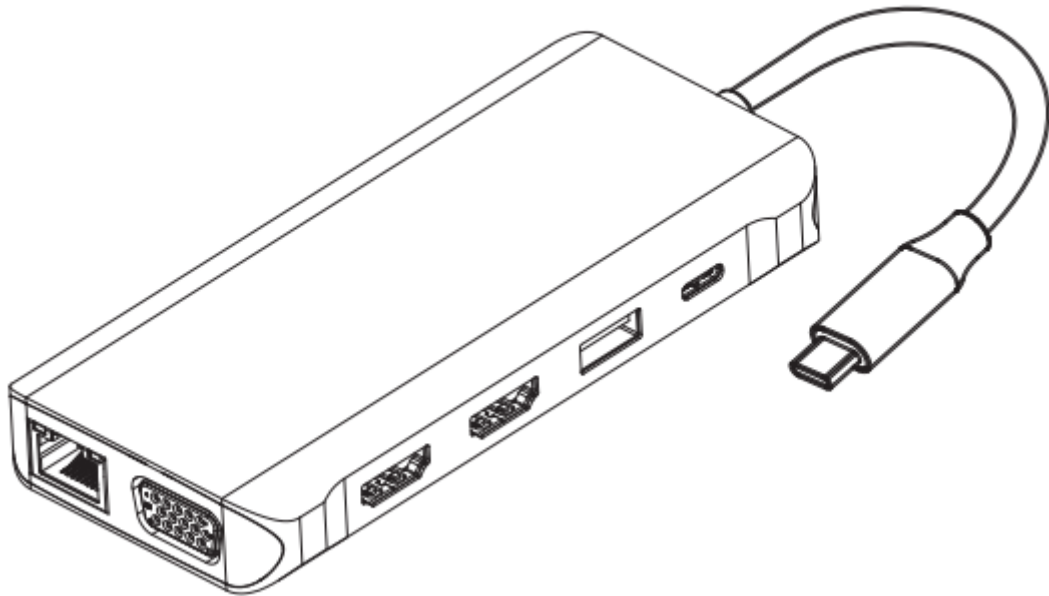

12-in-1 Dual-HDMI + VGA MST
DOCK

P/N **44466**
User's Manual

Thank you for purchasing this product

To ensure optimum performance and safety, read the following instructions before connecting, operating, or adjusting the product. Keep this manual for future reference.

Surge protection device recommended

This product contains sensitive electrical components that may have been damaged by electrical spikes, surges, electric shocks, lightning strikes, etc. The use of surge protection systems is highly recommended in order to protect and extend the life of your equipment.

Table of Contents

| | |
|-----------------------------|---|
| Introduction..... | 3 |
| Features..... | 3 |
| Package Contents..... | 3 |
| Diagram & Connection..... | 4 |
| Graphic Settings..... | 5 |
| Problems and Solutions..... | 7 |
| Remarks..... | 7 |
| Storage Conditions..... | 7 |

Introduction

The Monoprice 12-in-1 Dual-HDMI + VGA MST Dock provides a stable connection. Expand the female USB-C port to multiple connections, increasing your productivity. Also, keep your laptop charging while it still provides power to each attached external device. Extensive compatibility meets every need of almost all USB-C devices to unlock the best convenience.

Features

- USB-C Power Delivery
- HDMI Output Adapter
- VGA Adapter
- RJ45 Gigabit Ethernet Adapter
- USB-A 3.0 Data Transfer
- USB-A 2.0 Data Transfer
- SD/TF Card Reader
- Mic/Audio
- HDMI & VGA

Package Contents

- 1x Monoprice 12-in-1 Dual-HDMI + VGA MST Dock
- 1x User Manual

Diagram & Connection

DIAGRAM

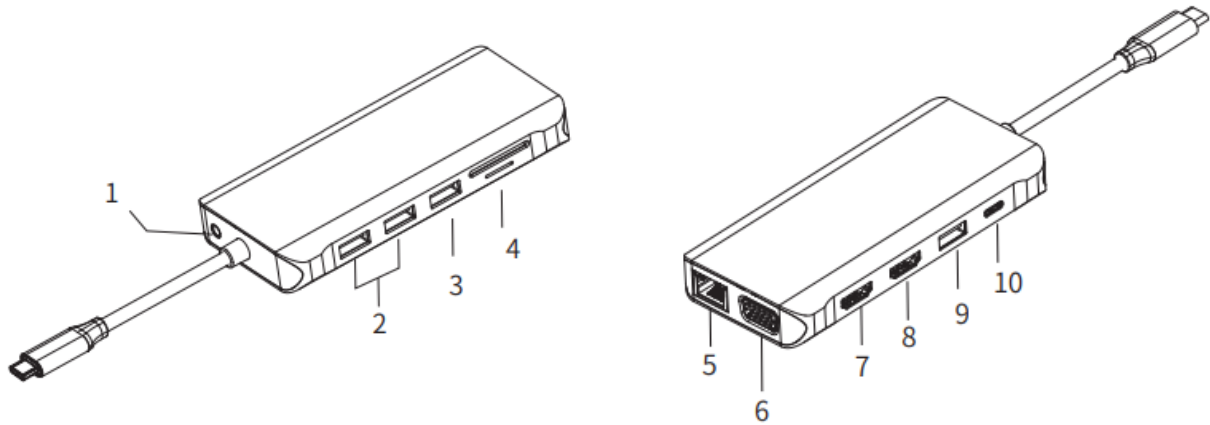

- 1. Audio/mic
- 2. USB 3.0
- 3. USB 2.0
- 4. SD & TF
- 5. RJ45 Gigabit Ethernet
- 6. VGA
- 7. HDMI 2
- 8. HDMI 1
- 9. USB 2.0
- 10. PD 3.0

CONNECTION

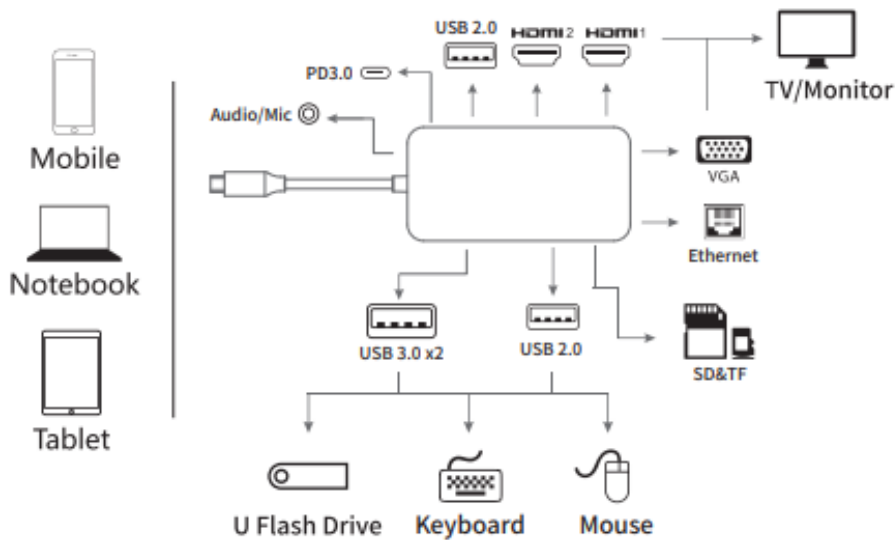

Graphic Settings

FOR WINDOWS 10

1. Clone Mode

Right click desktop > Graphic Settings > Display > Clone Display

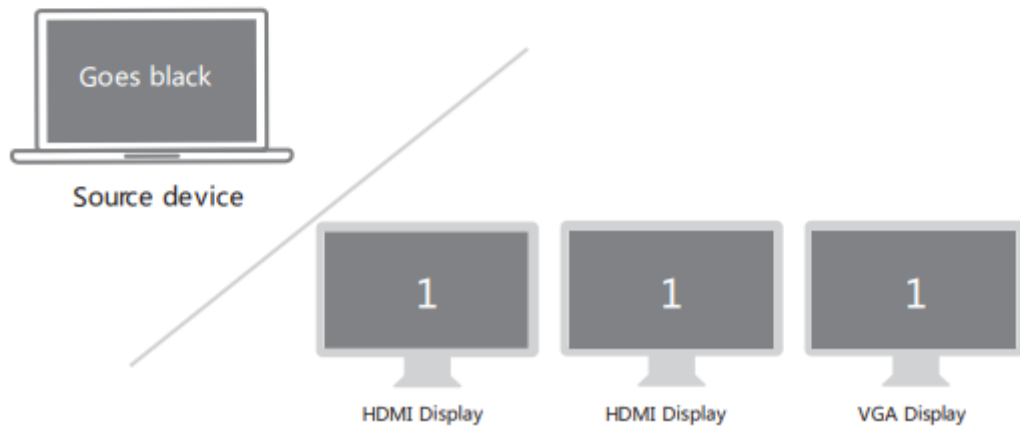
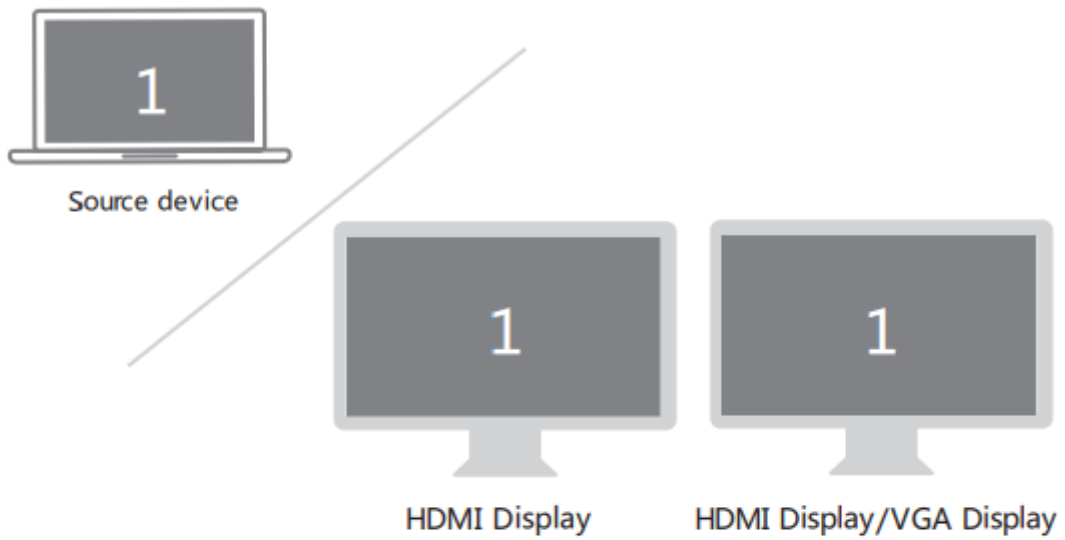

2. Extended Desktop (NOT supported by Apple)

Right click desktop > Graphic Settings > Display > Extended Desktop

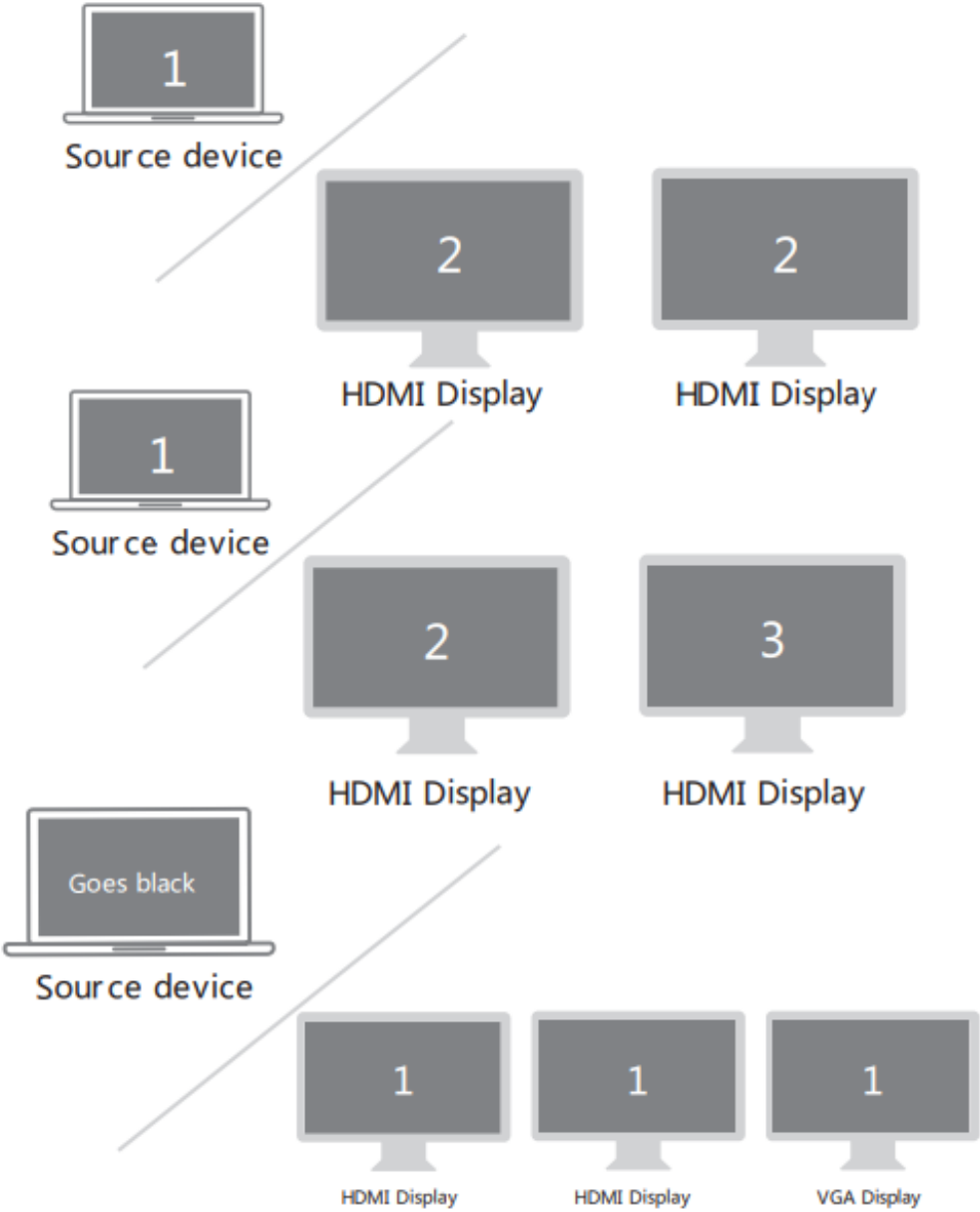

3. Collage

Right click desktop > Graphics Settings > Display > Collage > Check Enable

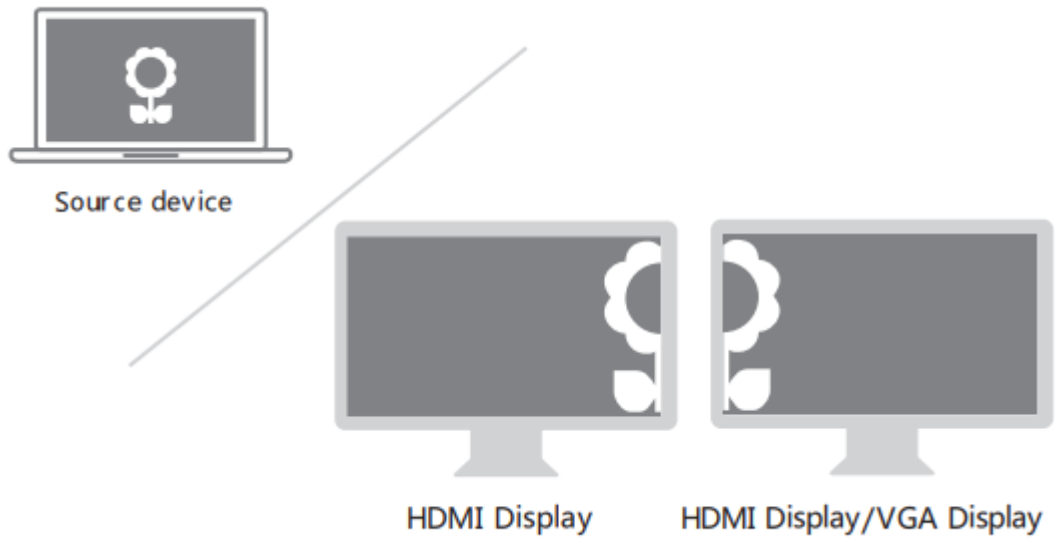

FOR MAC

1. Mirror Display

Apple logo > System Preference > Displays > Check Mirror Displays

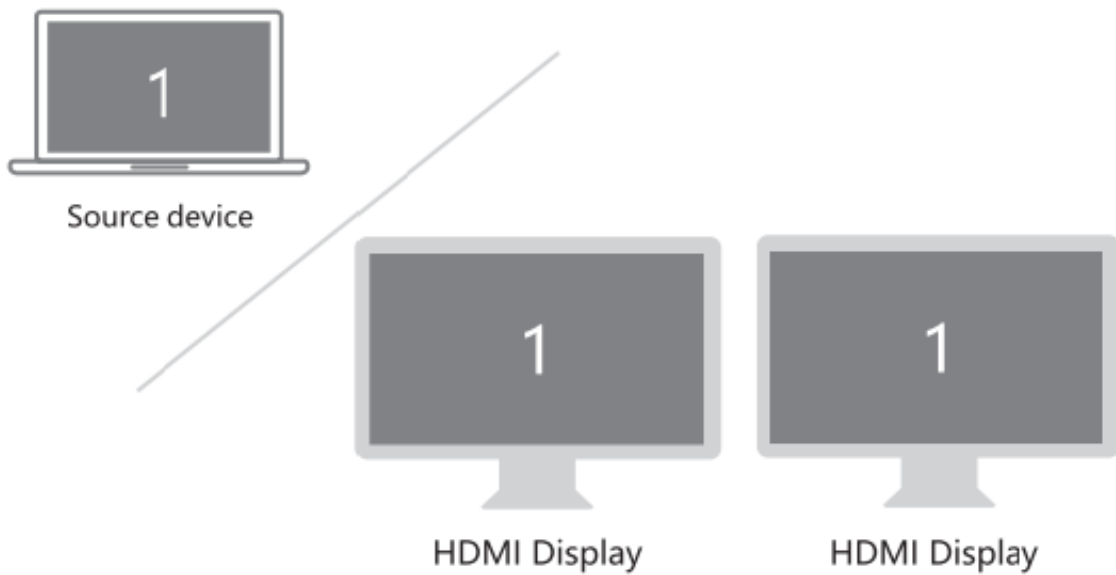

2. Extend Display

Apple logo > System Preferences > Displays > Uncheck Mirror Displays

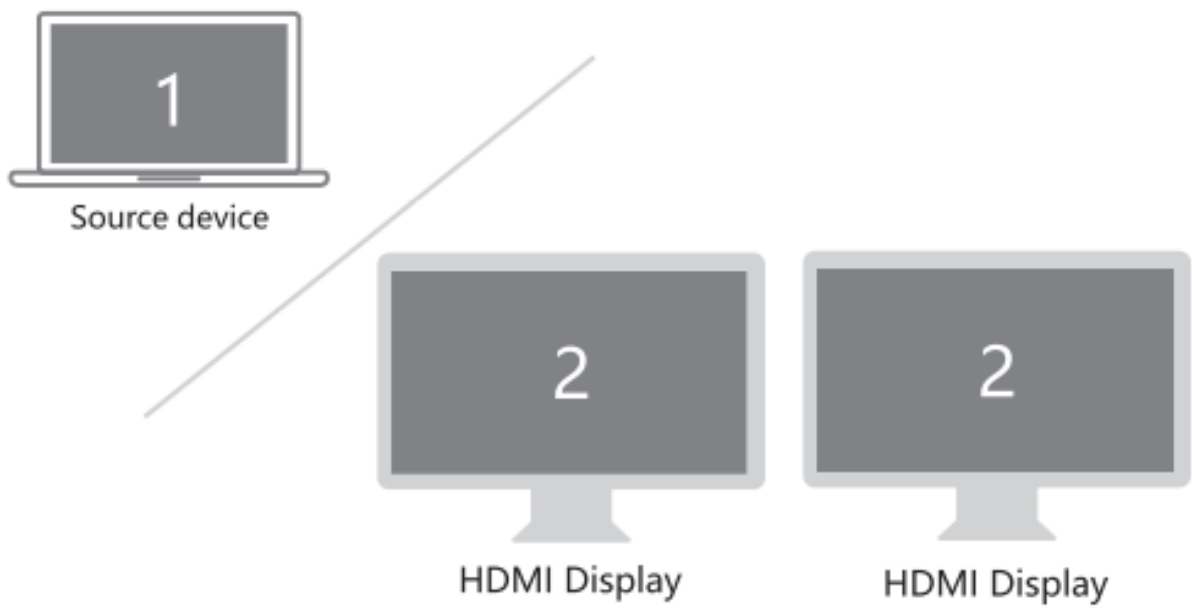

Other Settings

| | For Windows | For MacOS |
|---------------------|---|---|
| Resolution Settings | Right-click desktop > Display Settings > Select a display or resolution | Click Apple logo > System Preferences > Display > Click Scaled and choose a resolution |
| Sound Settings | Right-click desktop > Sound settings > Select a playback device | Click Apple logo > System Preferences > Sound > Select a device for sound output |

Problems and Solutions

| Problem Encountered | Solution |
|--|---|
| There is no video output. | Make sure your USB-C devices support video output. Make sure the connection is good. Use standard HDMI cable. |
| No audio output coming from HDMI. | Make sure there is audio output on the Monitor. Set the external monitor as the default audio output device. |
| The WIFI connection disappears when the hard drive is connected. | 2.4G easily interferes, try switching to a 5G network. Move the hard drive to a suitable place. |
| The monitors don't display under Windows 10 | Try right clicking desktop > Graphic settings > select one or more active display. |
| USB driver can't be identified. | Restart the device and connect to the hub again. |
| The display screen drops after connecting to a large hard drive. | Connect your charger. |

Other Remarks

1. The USB-C female port of this product is only for charging devices that support USB Power Delivery (PD).
2. The device supports VGA and HDMI simultaneous output; however, the maximum resolution is 1080P when using them simultaneously.
3. This product DOES NOT support replication or extended displays when connecting to a gaming device.
4. When a device with a large power consumption cannot be connected normally, please connect the charger to the USB-C female port of the product to power the computer, hard disk, etc.

Storage Conditions

| | |
|-------------------------------|---------------|
| Ambient Operating Temperature | 32°F - 158°F |
| Storage Temperature | -22°F - 248°F |
| Ambient Operating Humidity | 20% - 80% RH |
| Storage Humidity | 20% - 90% RH |

Specifications

| | |
|-------------------------------------|---|
| PN | 44466 |
| Connector | USB 3.1 Type-C Connector |
| Dimension | 4.8x2.13x0.65 inches |
| Cord Length | 6 inches |
| Weight | 0.37 lb |
| USB-C Female Charging Port (PD 3.0) | Only for USB-C laptop or USB-C smartphone charging. The charging power you view is the actual power provided by the PD adapter minus the power consumed by all connected devices. |
| HDMI Output Port | Resolution up to 4K/30Hz if two of them play simultaneously. When dual or triple display with VGA, they will be 1080P/60Hz. If your source is DP 1.4, HDMI 2 can reach up to 4K/60Hz during single play. |
| VGA Output Port | Resolution up to 1920x1080P/60Hz |
| RJ45 Gigabit Ethernet | Speed up to 1000Mbps max |
| USB-A 3.0 | Speed up to 5Gbps, 5V/0.9A at 4.5W |
| USB-A 2.0 | Speed up to 480Mbps, 5V/0.5A at 2.5W |
| SD/TF Card Reader | Support memory card capacity: up to 512 GB Read/write speed" up to 104MB/s |
| Mic/Audio | Support Mic and Stereo Audio 2-in-1 Jack Standard: CTIA |
| Requirements | Device with available and fully functional USB-C port |
| Plug and Play Supported | Yes |

CUSTOMER SERVICE

The Monoprice Customer Service department is dedicated to ensuring that your ordering, purchasing, and delivery experience is second to none. If you have any problems with your order, please give us an opportunity to make it right. You can contact a Monoprice Customer Service representative through the Live Chat link on our website www.monoprice.com or via email at support@monoprice.com. Check the website for support times and links.

TECHNICAL SUPPORT

Monoprice™ is pleased to provide free, live, online technical support to assist you with any questions you may have about installation, setup, troubleshooting, or product recommendations. If you ever need assistance with your new product, please come online to talk to one of our friendly and knowledgeable Tech Support Associates. Technical support is available through the online chat button on our website www.monoprice.com or through email by sending a message to tech@monoprice.com. Check the website for support times and links.

To download the latest drivers, firmware, manuals, etc., go to www.monoprice.com and type **44466** into the search bar. If available, support files are linked at the bottom of the product page.

REGULATORY COMPLIANCE

Notice for FCC



This device complies with Part 15 of the FCC rules. Operation is subject to the following two conditions: (1) this device may not cause harmful interference, and (2) this device must accept any interference received, including interference that may cause undesired operation.

Modifying the equipment without Monoprice's authorization may result in the equipment no longer complying with FCC requirements for Class B digital devices. In that event, your right to use the equipment may be limited by FCC regulations, and you may be required to correct any interference to radio or television communications at your own expense.

This equipment has been tested and found to comply with the limits for a Class B digital device, pursuant to Part 15 of the FCC Rules. These limits are designed to provide reasonable protection against harmful interference in a residential installation. This equipment generates, uses and can radiate radio frequency energy and, if not installed and used in accordance with the instructions, may cause harmful interference to radio communications. However, there is no guarantee that interference will not occur in a particular installation. If this equipment does cause harmful interference to radio or television reception, which can be determined by turning the equipment off and on, the user is encouraged to try to correct the interference by one or more of the following measures:

- Reorient or relocate the receiving antenna.
- Increase the separation between the equipment and receiver.
- Connect the equipment into an outlet on a circuit different from that to which the receiver is connected.
- Consult the dealer or an experienced radio/TV technician for help.

Notice for ISED Canada

This Class B digital apparatus complies with Canadian ICES-003.

Cet appareil numérique de la classe B est conforme à la norme NMB-003 du Canada.



HDMI, HDMI High-Definition Multimedia Interface, and the HDMI logo are registered trademarks of HDMI Licensing Administrator, Inc. in the United States and other countries.

Monoprice™ and all Monoprice logos are trademarks of Monoprice I



TECHNOLOGY AT PRICES THAT MAKE SENSE

www.monoprice.com

Need Help? We're here for you!

Contact us: www.monoprice.com/contactus

Product pictures are for reference only.

Specifications described herein are subject to change without prior notification.

Monoprice™ and all Monoprice logos are trademarks of Monoprice Inc.

Copyright © 2022 Monoprice, Inc. All rights reserved.

Monoprice, Inc.

1 Pointe Drive, Suite 400

Brea, CA 92821 – USA

www.monoprice.com