

Dismantling Information for Use by Professional Recyclers

ORIGINAL MANUAL ISSUE DATE: 2023.06

Model:

FW-55BZ35L	FW-65BZ35L	FW-75BZ35L	FW-85BZ35L
FW-55BZ40L	FW-65BZ40L	FW-75BZ40L	FW-85BZ40L

9-888-916-42

LCD MONITOR

SONY®

Sony EMCS (Malaysia) Sdn. Bhd., HES-M

© 2023.07

Conditions of Use:

- (1) Please use this information only for the purpose of performing repair and recycling Sony products. Using this information for any purpose other than the purpose described foregoing is forbidden.
- (2) Do not copy, replicate, reproduce, alter, translate, transmit, sell, lease, or distribute this information in whole or in part without the prior written permission of the author.

Revision of Information:

This information may be changed or updated at any time without any prior notice. Please confirm that this information is up-to-date before using it.

MODEL LISTS

Self Diagnosis
Supported model

MODEL REMOTE DESTINATION

[TKB Model]

FW-55BZ35L RMT-TB400U CEI

FW-65BZ35L RMT-TB400U CEI

FW-75BZ35L RMT-TB400U CEI

FW-85BZ35L RMT-TB400U CEI

[TXB Model]

FW-55BZ40L RMT-TB400U CEI

FW-65BZ40L RMT-TB400U CEI

FW-75BZ40L RMT-TB400U CEI

FW-85BZ40L RMT-TB400U CEI

RMT-TB400U



TOOLS & EQUIPMENTS

1 LIST OF ITEMS TO BRING

- i. Screwdriver (e.g., #2 Phillips Screwdriver).
- ii. Multimeter.
- iii. ESD Wrist Straps.
- iv. Metal Washer (Flat) or Coin - to remove Rear Cover.

Thickness: approx. 1.5 mm
Diameter: 20~25 mm (wrap in tape (L=50 mm))

- v. Ruler - to remove Rear Cover.

Plastic or Metal Ruler (In case of Metal ruler,
wrap in tape (L=50 mm) for prevent scratches)

- vi. Service Manual

2 OPTIONAL EQUIPMENTS

- i. Screwdriver (e.g., #0 Phillips Screwdriver).
- ii. Parts Tray for loose screws and small items.
- iii. Flashlight.
- iv. Service Manual

For Surface Mounted Parts / Connector

Hot-Air type soldering iron is needed

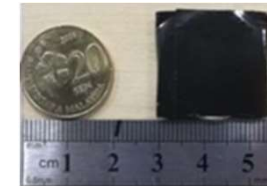

SAFETY NOTES

1-1. Warnings and Caution.

- 1) CAUTION :These servicing instructions are for use by qualified service personnel only.
- 2) To reduce the risk of electric shock, do not perform any servicing other than that stated in the operating instructions unless you are qualified to do so.
- 3) WARNING!!: An isolation transformer should be used during any service to avoid possible shock hazard, because of live chassis. The chassis of this receiver is directly connected to the ac power line. The replaceable fuse should be in the neutral of the mains supply. When replacing the fuse, the mains must be disconnected to de-energize the phase conductors. (*Except AC ADAPTOR, because it does not carry out replacing an internal fuse.)
- 4) CARRYING THE TV: be sure to follow these guidelines to protect your property and avoid causing serious injury:
 - Carry the TV with an adequate number of people; larger size TVs require two or more people.
 - Correct hand placement while carrying the TV is very important for safety and to avoid damages.
- 5) SAFETY-RELATED COMPONENT WARNING!!: Components identified by shading and  mark on the exploded views, and in the parts list are critical for safe operations. Replace these components with Sony parts whose part numbers appear as shown in this manual or in supplements published by Sony. Circuit adjustments that are critical for safe operations are identified in this manual. Follow these procedures whenever critical components are replaced, or improper operation is suspected.

6) IMPORTANT REMINDER FOR TV MAIN BOARD REPLACEMENT:

It is mandatory for service centers to confirm the TV's system information after each repair is carried out with Main board replacement. Whenever a TV Main board is replaced, the correct TV Model and Serial number must be reinserted into memory. This is a MANDATORY procedure that each service center must apply. Please refer to the chapter of ADJUSTMENT in this service manual to find out how to set the model number and serial number in service mode.

1-2. Caution Handling of LCD Panel.

When repairing the LCD Panel, make sure you are grounded with a wrist band.

When repairing the LCD Panel on the wall, the panel must be secured using the 4 mounting holes on the rear cover.

- 1) Do not press the panel or frame edge to avoid the risk of electric shock.
- 2) Do not scratch or press on the panel with any sharp objects.
- 3) Do not leave the module in high temperature or in areas of high humidity for an extended period.
- 4) Do not expose the LCD panel to direct sunlight.
- 5) Avoid contact with water. It may cause short circuit within the module.
- 6) Disconnect the AC power when replacing the backlight.
- 7) Always clean the LCD panel with a soft cloth material.
- 8) Handle the wires or connectors of the backlight circuit with care. Damaging the wires may cause a short circuit.
- 9) Protect the panel from ESD to avoid damaging the electronic circuit (C-MOS).

SAFETY NOTES

10) During the repair, DO NOT leave the POWER ON or Burn-in period for more than 1 hour while the TV is facing down on a cloth. Refer Figure 1.

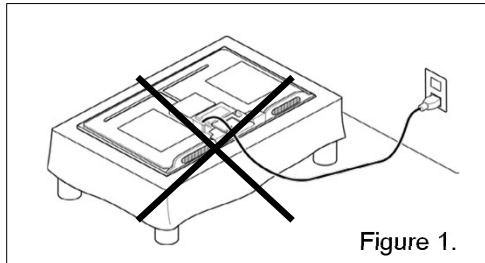

1-3. Caution_for_Board_handling.

The following problems will occur due to handling of the IC mounted on the board

- Solder crack due to substrate handling (stress).
- IC breakdown due to static electricity (ESD).

When repairing the TV at the customer's home or service station or Repair of defect board, please pay attention to the handling of the board.

Substrate that needs attention for handling :

- Main Board (B** Board)
- Backend Board (D** Board)

※ Things to prepare in advance.



※ Caution: ESD wrist-strap to be checked daily.

Use Multi-meter to make sure resistance of ESD wrist-strap is OK.
(R=750K Ohms to 35Mega Ohms)

SAFETY NOTES

ESD cushion / sheet
Please use a bag containing the board or a special seat



1) Caution for Board handling(Stress).Be sure to observe the following contents.

① Hold the board with both hands



② Do not hold/push Heat-Sink



③ Handle with care. Do not swing

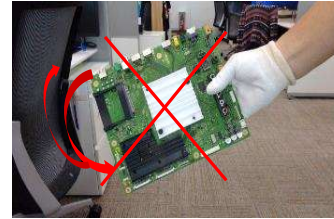

④ Regardless of Good board or Defective board, always put it on ESD cushion / sheet slowly.



⑤ Do not stack up



SAFETY NOTES

- ⑥ Keep vertical position and put in/take out from Box.
Always put into ESD bag then place into Box/Container Box



- ⑦ After take defective board out from TV, put it into ESD bag. Do not place on floor mat/carpet direct and always put it on ESD cushion

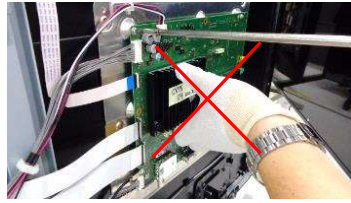
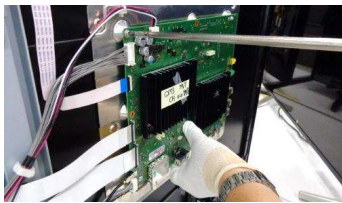

2) Caution for Board handling (ESD). Be sure to observe the following contents

- ① When take off Rear-Cover, do not touch to board



- ② Use ESD wrist-strap



※Installation example of wrist-strap.

Please connect the clip to the metal part of the chassis of the TV with the wristband grounded. Below is a grounding example of each model.

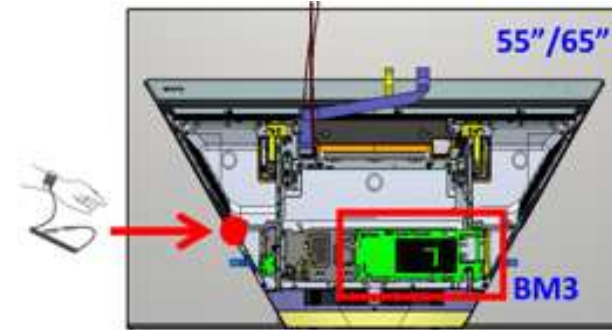

<K*-65Z9F>

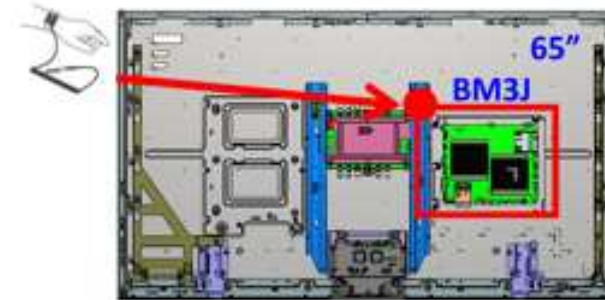

※Caution : ESD wrist-strap to be checked daily.

Use Multi-meter to make sure resistance of ESD wrist-strap is OK.

(R=750K Ohms to 35Mega Ohms)

SAFETY NOTES

- ③ When holding board, do not hit or touch to Plastic part(s)



- ④ After take defective board out from TV, put it into ESD bag.
Do not place on floor mat/carpet direct. And, always put it on ESD cushion



1-4. Caution About the Lithium Battery.

- 1) Danger of explosion if battery is incorrectly replaced.
Replace only with the same or equivalent type.
- 2) Outer case broken battery should not contact to water.

SAFETY NOTES

1-5. Safety Check-Out

After correcting the original service problem, perform the following safety checks before releasing the set to the customer:-

- 1) Check the area of your repair for unsoldered or poorly soldered connections. Check the entire board surface for solder splashes and bridges.
- 2) Check the inter board wiring to ensure that no wires are pinched or contact high-wattage resistors.
- 3) Check all control knobs, shields, covers, ground straps and mounting hardware have been replaced. Be certain you have replaced all the insulators.
- 4) Look for unauthorized replacement parts, particularly transistors that were installed during a previous repair. Point them out to the customer and recommend their replacement.
- 5) Look for parts which show obvious signs of deterioration even though functioning. Point them to the customer and recommend for replacement.
- 6) Check the line cords for cracks and abrasion. Recommend the replacement of any such line cord to the customer.
- 7) Check the antenna terminals, metal trim, metalized knobs, screws and all other exposed metal parts for AC leakage. Check leakage test as described next.
- 8) For safety reasons, repairing the Power board and/or Inverter board is prohibited.

1-6. Leakage Test.

(To protect electric shock when customer touch the terminal.). Leakage current can be measured by V: Voltmeter or oscilloscope (r.m.s or peak reading).

Stabilized power supply instrument and isolated voltage transformer:

Use too much current capacity and isolated voltage transformer does not need to use stabilized power supply equipment.

Specification of RMS voltmeter: Input resistance > 1 Mohm, Input capacitance < 200 pF, Frequency range: 15 Hz – 1MHz . Refer Figure 2. Isolated type voltmeter (FLUKE 8921A etc *1).

*1 Not use FLUKE 8920A that connected to protective earth by diode.

Leakage current of measurement instrument is less than 10µArms when under test equipment AC plug is opened.

Set up the following condition and turn on the set. Applied voltage: Nominal input voltage (Description on Nameplate).

Measure the leakage current between one phase conductor and neutral for terminal A and terminal B.

Read rms value, and then calculate to peak value PEAK VALUE = $\sqrt{2}$ RMS VALUE.

Comply with the following requirement.

Class II equipment (2-pin plug): for each terminal, the worst value of measurement must not exceed AC 350µA peak).

Note: including AC adaptor, AC adaptor/DC operated unit combination.

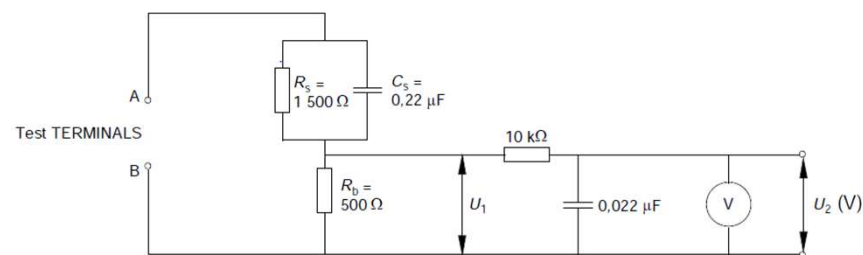

Figure 2 – Measuring network for Leakage Current

IEC 802/98

SAFETY NOTES

1-7. How to Find a Good Earth Ground.

- 1) A cold-water pipe is a guaranteed earth ground; the cover-plate retaining screw on most AC outlet boxes is also at earth ground.
- 2) If the retaining screw is to be used as your earth ground, verify that it is at ground by measuring the resistance between it and a cold-water pipe with an ohmmeter. The reading should be zero ohms.
- 3) If a cold-water pipe is not accessible, connect a 60- to 100-watt trouble-light (not a neon lamp) between the hot side of the receptacle and the retaining screw. Try both slots, if necessary, to locate the hot side on the line; the lamp should light at normal brilliance if the screw is at ground potential (see Figure 3).

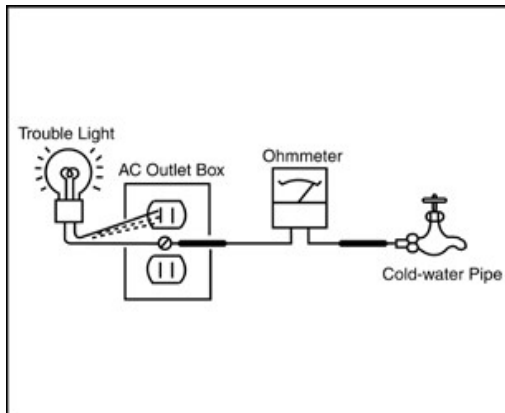

Figure 3. Checking for earth ground.

1-8. Lead Free Information

The circuit boards used in these models have been processed using Lead Free Solder. The boards are identified by the LF logo located close to the board designation.



Figure 4: LF Logo

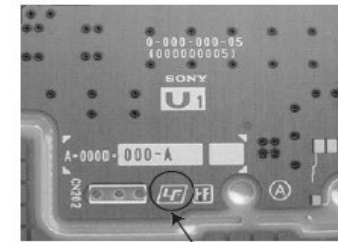

Figure 5: LF logo on circuit board

The servicing of these boards requires special precautions. It is strongly recommended to use Lead Free Solder material in order to guarantee optimal quality of new solder joints.

DISASSEMBLY AND REMOVAL CAUTION 55"

REAR COVER

1. Remove screw from Rear & Ac cover. (Qty: 5)

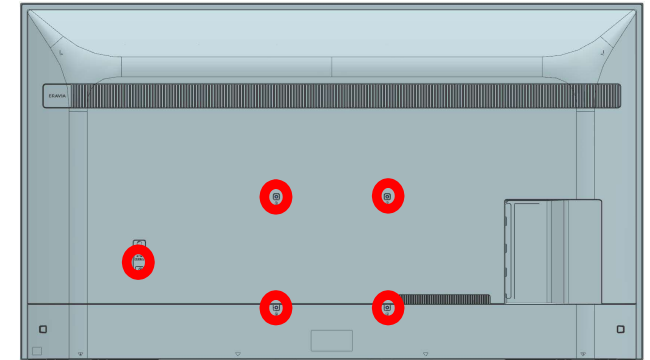

2. Release bottom hook (Qty: 6)

① Unhook two hooks which is closest to center simultaneously to prevent lock back.

② Locate both hooks and use coin or jig to unhook.

③ Can use mirror to assist locating the hook position.

④ Wrap coin in tape. (55mm x 25mm)

⑤ Thickness of coin approximately 2mm.

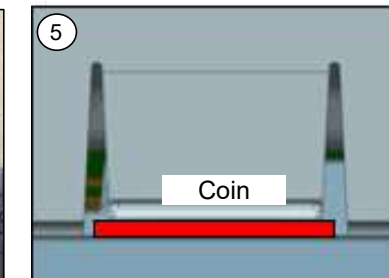
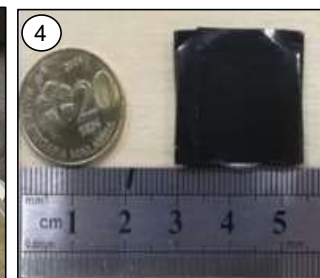
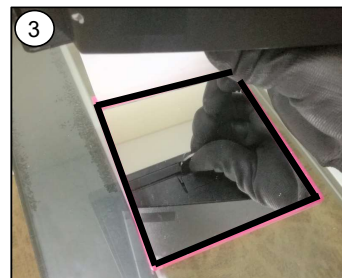
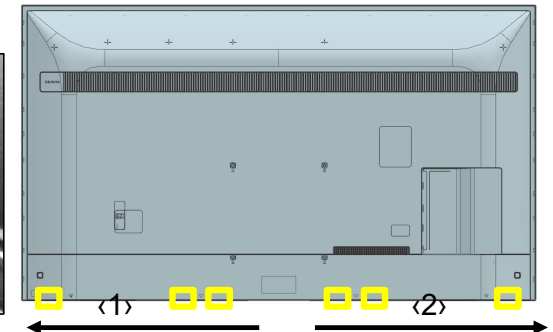
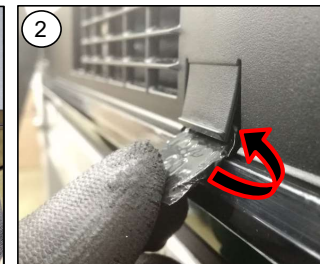

Note:
Refer to next page for the location of hooks
□ = Btm Back Chassis-Bezel Hook

DISASSEMBLY AND REMOVAL CAUTION 55"

REAR COVER

2. Bottom hook position.

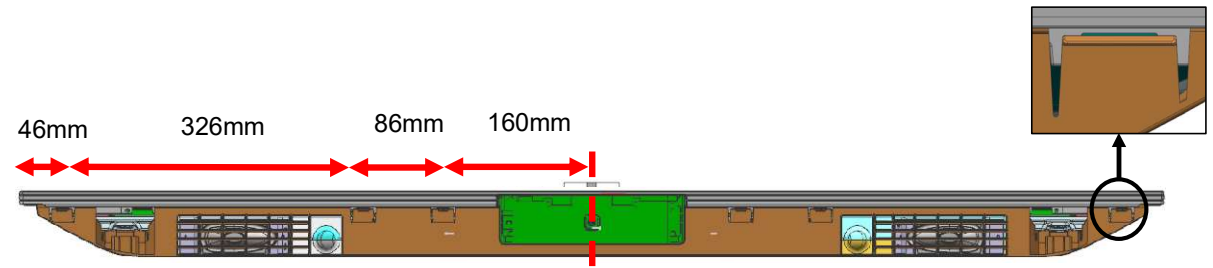

3. Release corner hook (Qty: 2)

- ① When releasing hook, pull the Rear Cover corner and insert jig.
- ② Ensure that the jig is pulled backward.
- ③ DO NOT pivot on Bezel when inserting jig.

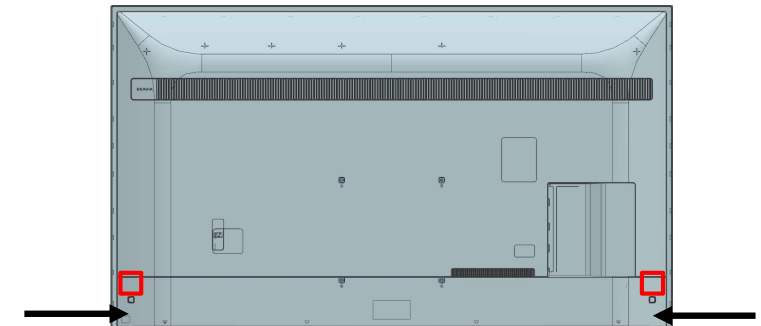

Note:

- 1) Ruler or jig to release corner hook.
- 2) Wrap ruler with tape to prevent scratch

□ =Back Chassis-Rear Cover Hook

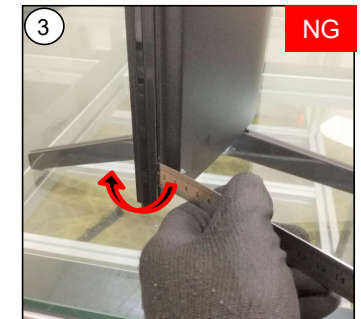
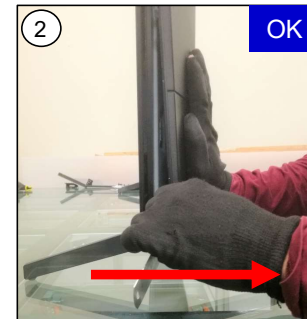



DISASSEMBLY AND REMOVAL CAUTION 55"

REAR COVER

4. Remove left side hook. (Qty: 3)

- ① Grip Rear Cover with hand and unhook Rear Cover – Bezel hook using ruler or jig
- ② Flex the Rear cover outwards to unhook. Support set with arm.

Note:

-  Back Chassis-Rear Cover Hook
-  Rear Cover-Bezel Hook

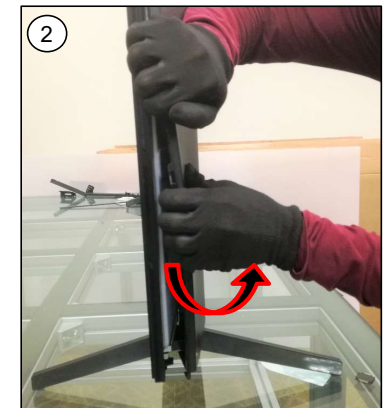
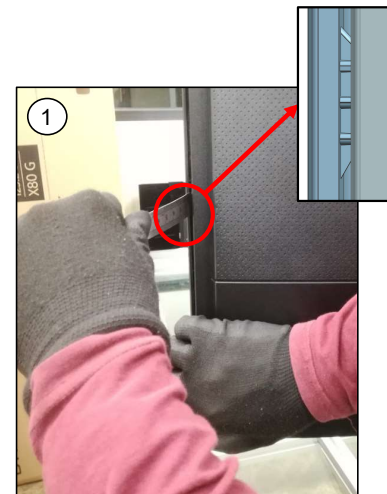
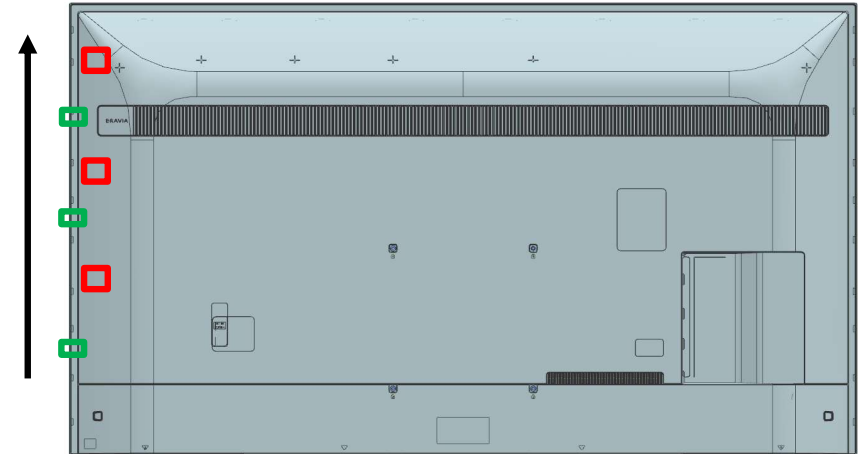



DISASSEMBLY AND REMOVAL CAUTION 55"

REAR COVER

5. Remove right side hook. (Qty: 3)

- ① Unhook side hooks ①
- ② Pull Rear Cover below the Side Jack to release the hooks ②
- ③ Proceed to unhook remaining side hooks ③

Note:

-  Back Chassis-Rear Cover Hook
-  Rear Cover-Bezel Hook
-  SJB hook

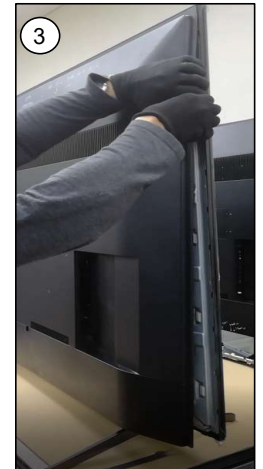
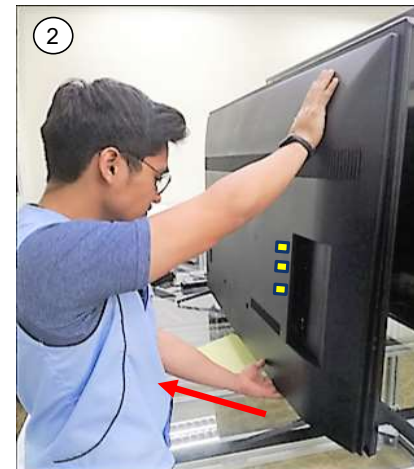
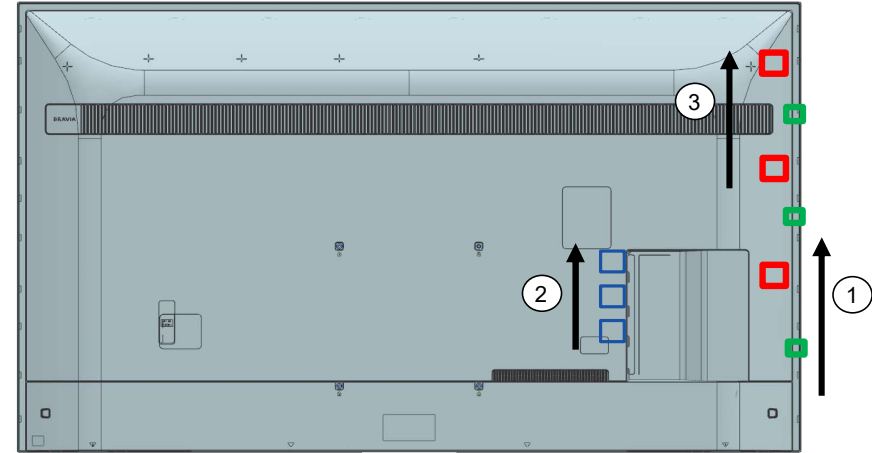

DISASSEMBLY AND REMOVAL CAUTION 55"

REAR COVER

6. Release top row hooks. (Qty: 6)

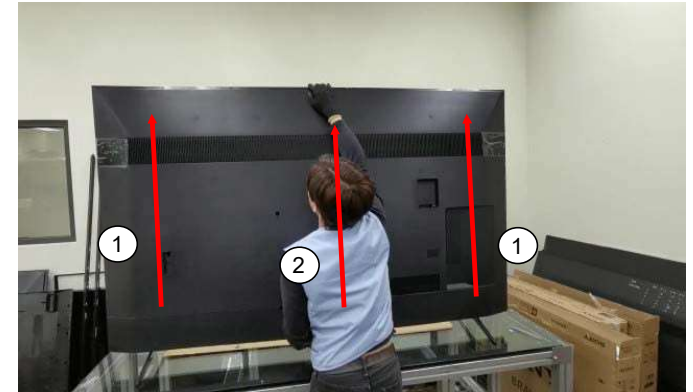

- ① Tilt the Rear Cover and push upwards on the left or right side.
- ② Lift the Rear Cover off from the center.

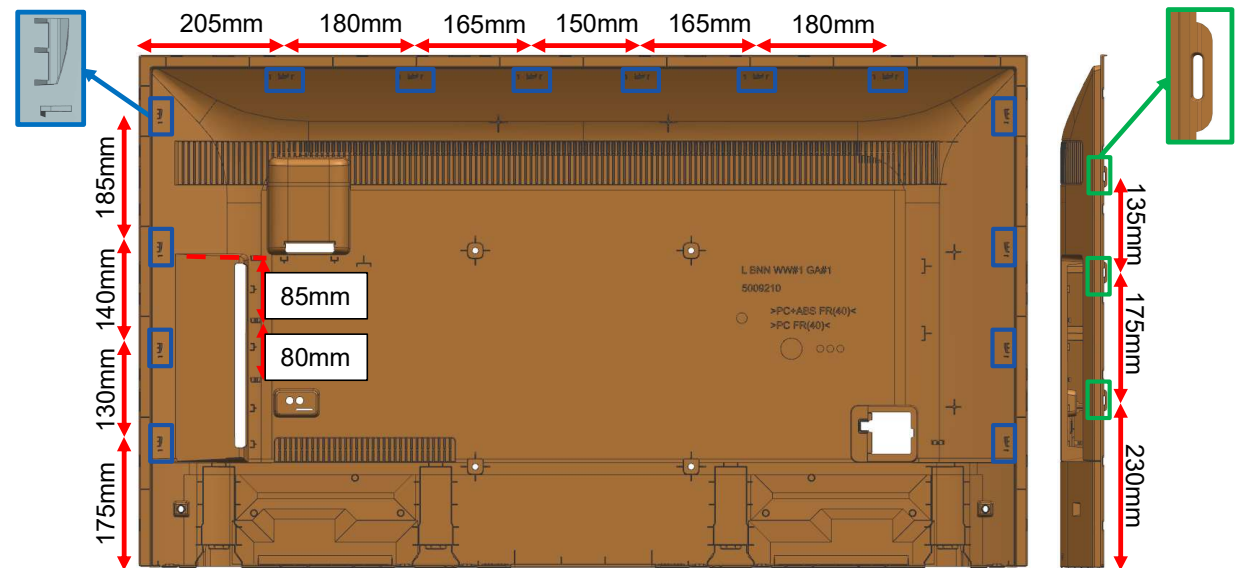

Hook positioning.



EXPLODED VIEW AND PART LIST 55"



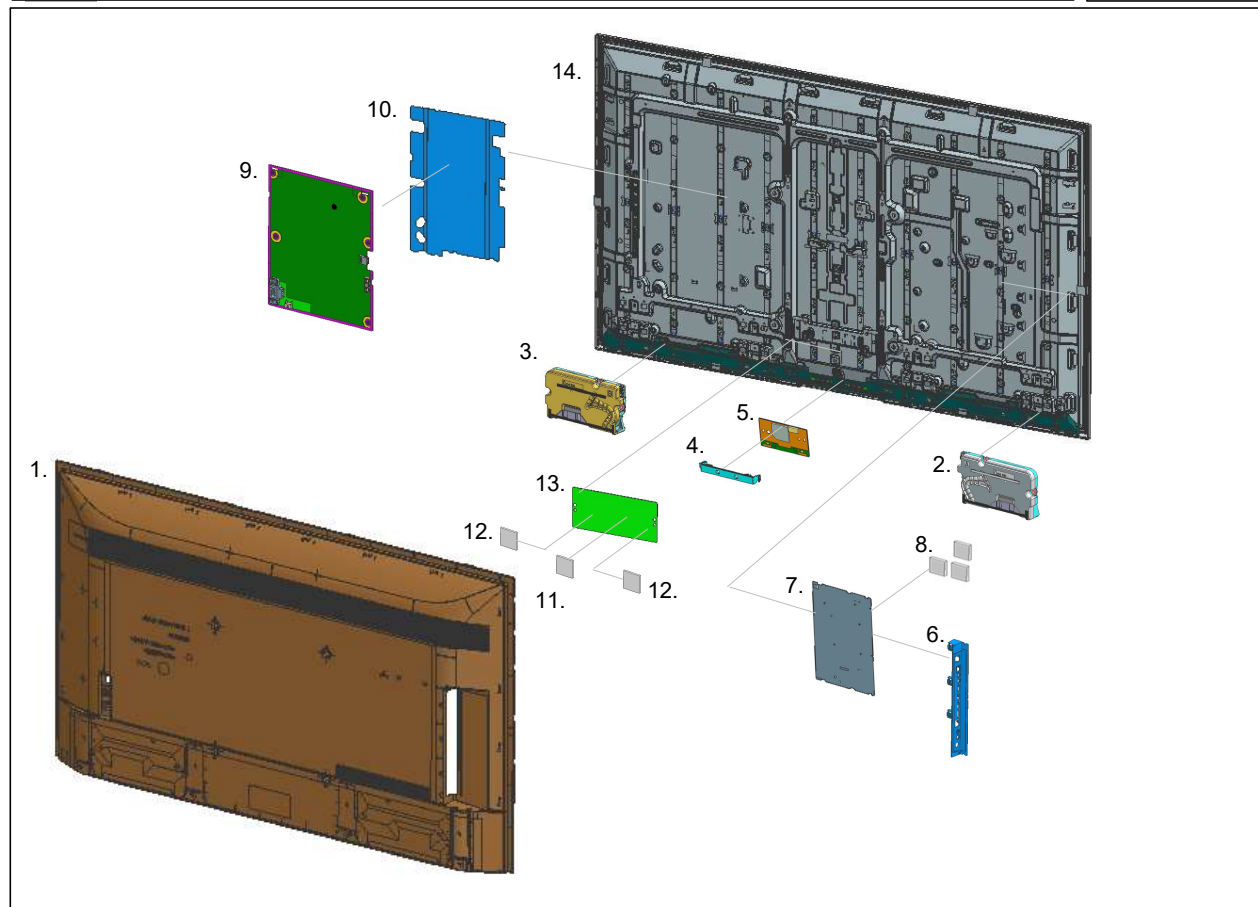

- Place the TV set facing downwards on a stable, level surface before disassembly and assembly of parts.
-  and shaded parts are critical for safety. Replace only with part number specified.
-  Parts contain confidential information. Strictly follow the instruction whenever the components are repaired and/or replaced

- \ (*) Parts are not stocked since they are seldom required for routine service. Some delays should be anticipated when ordering these components.
- \ Picture provided in this section might have slight difference from the actual sets.
- \ The reference number beside the part indicates the disassembly sequence.
- \ Remove screws before disassembly. Unplug connectors before disassembly





EXPLODED VIEW AND PART LIST 55”

SET PART LIST

REF. NO	PART NO.	DESCRIPTION	REMARKS
 7	A-5057-156-A	COMPL_SVC_BM5A23_TKB_TXB_WW	Printed Circuit Board, incl. capacitors
 9	1-004-422-22	GL01B-STATIC CONVERTER (TV)	Internal Power Supply
 14	A-5061-766-A	P-MOD (YS DM055EN001)(SVC)	35L (Liquid Crystal Display)
 14	A-5061-768-A	P-MOD (YS DM055IN001)(SVC)	40L (Liquid Crystal Display)

OTHER PART

 1-005-634-21	C7L AC POWER CORD SETS (EU)	Cable
 1-005-641-12	C7L AC POWER CORD SETS (UK)	Cable

EXPLODED VIEW AND PART LIST 55"

CONNECTOR

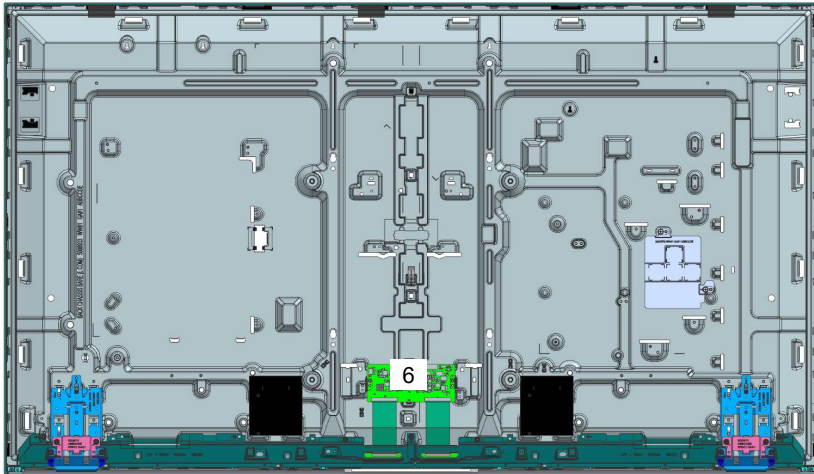
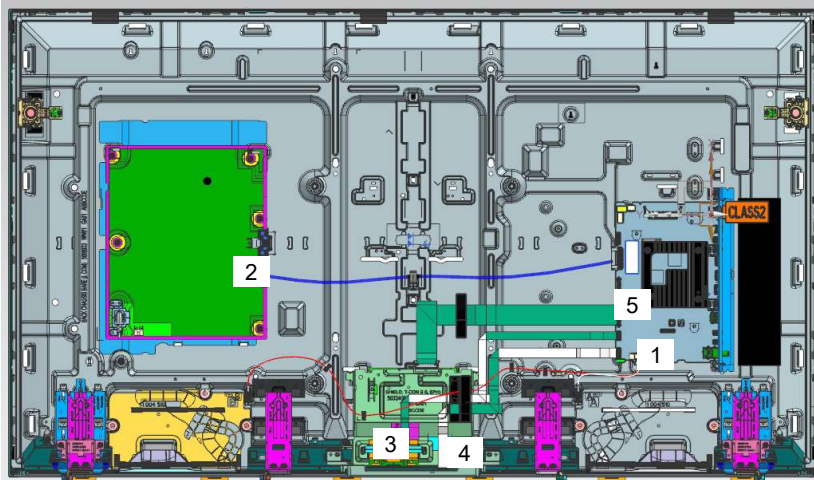

REF. NO	PART NO.	DESCRIPTION	REMARKS
1	1-006-501-43	CONNECTOR ASSY 4P (SP)	CN3550(B)-SP(1)
2	1-006-502-23	CONNECTOR ASSY 30P	CN1701(B)-CN6401(G)(1)
3	1-006-506-11	FLEXIBLE FLAT CABLE 20P	CN3801(B)-J1(WIFI/BT)(1)
4	1-006-509-12	FLEXIBLE FLAT CABLE 25P	CN1200(B)-CN102(H)(1)
5	1-010-543-21	FLEXIBLE FLAT CABLE 51P	CN4200(B)-U1(T-CON)(1)
6	1-014-423-11	FLEXIBLE FLAT CABLE 68P	SOURCE BOARD- T-CON(2)

DISASSEMBLY AND REMOVAL CAUTION 65”

REAR COVER

1. Remove screw from Rear & Ac cover. (Qty: 5)

○ SCREW, +PSW M5X14

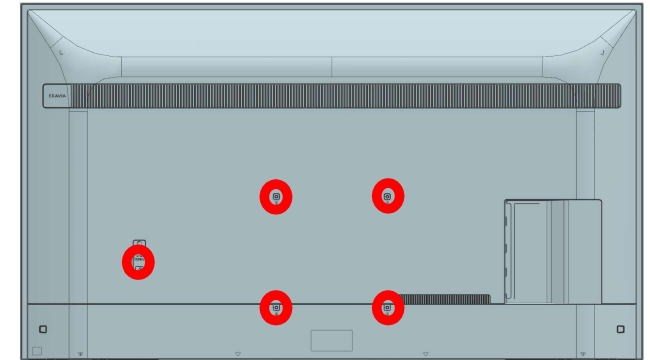

2. Release bottom hook (Qty: 8)

① Unhook two hooks which is closest to center simultaneously to prevent lock back.

② Locate both hooks and use coin or jig to unhook.

③ Can use mirror to assist locating the hook position.

④ Wrap coin in tape. (55mm x 25mm)

⑤ Thickness of coin approximately 2mm.

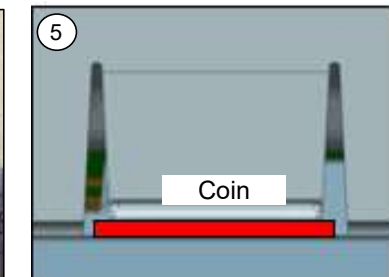
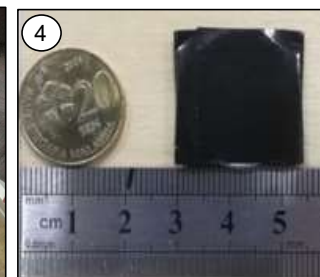
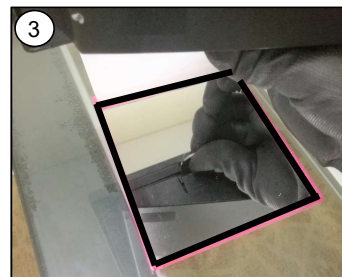
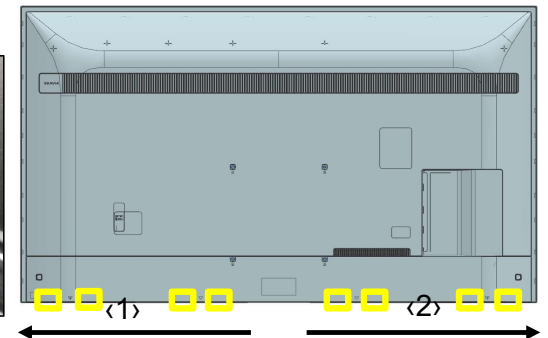
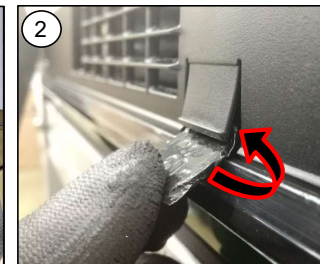

Note:
Refer to next page for the location of hooks
□ = Btm Back Chassis-Bezel Hook

DISASSEMBLY AND REMOVAL CAUTION 65"

REAR COVER

2. Bottom hook position.

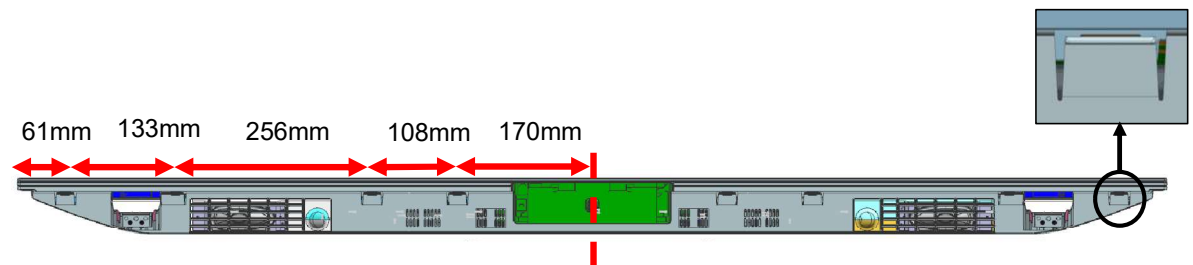

3. Release corner hook (Qty: 2)

- ① When releasing hook, pull the Rear Cover corner and insert jig.
- ② Ensure that the jig is pulled backward.
- ③ DO NOT pivot on Bezel when inserting jig.

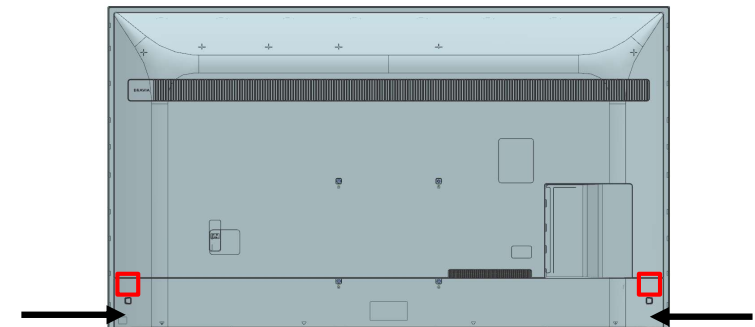

Note:

- 1) Ruler or jig to release corner hook.
- 2) Wrap ruler with tape to prevent scratch

□ =Back Chassis-Rear Cover Hook

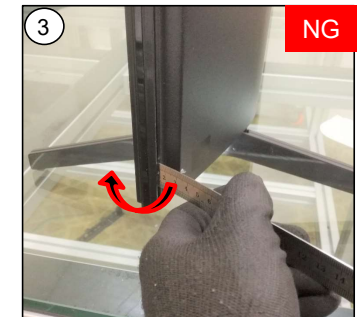
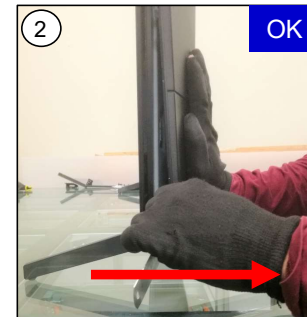



REAR COVER

4. Remove left side hook. (Qty: 4)

- ① Grip Rear Cover with hand and unhook Rear Cover – Bezel hook using ruler or jig
- ② Flex the Rear cover outwards to unhook. Support set with arm.

Note:

-  Back Chassis-Rear Cover Hook
-  Rear Cover-Bezel Hook

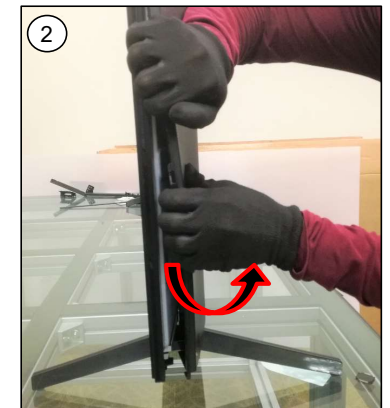
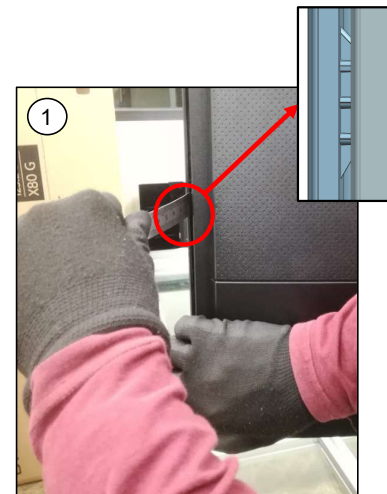
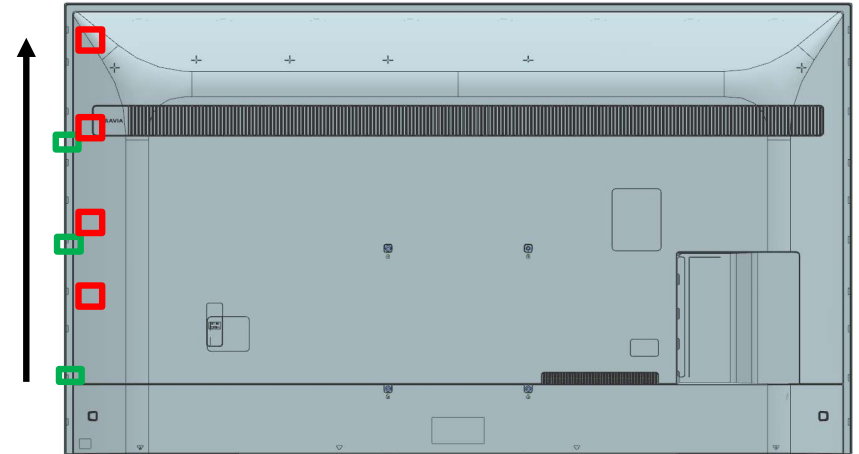



DISASSEMBLY AND REMOVAL CAUTION 65"

REAR COVER

5. Remove right side hook. (Qty: 4)

- ① Unhook side hooks ①
- ② Pull Rear Cover below the Side Jack to release the hooks ②
- ③ Proceed to unhook remaining side hooks ③

Note:

-  Back Chassis-Rear Cover Hook
-  Rear Cover-Bezel Hook
-  SJB hook

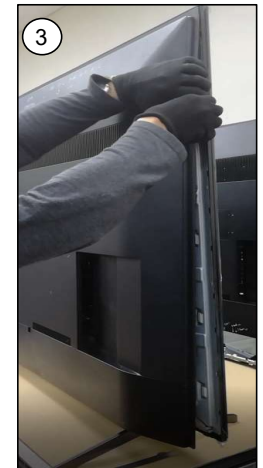
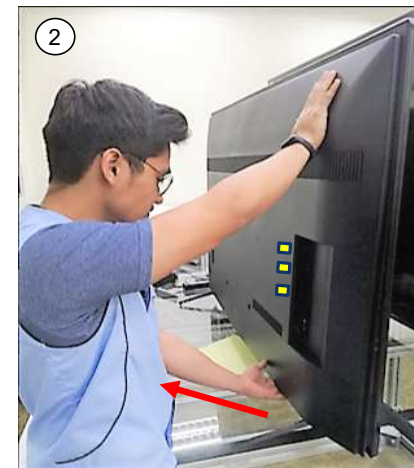
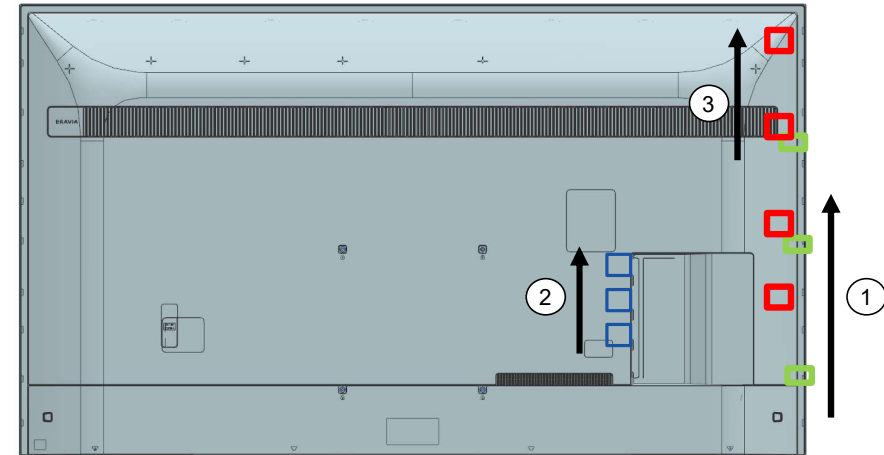

DISASSEMBLY AND REMOVAL CAUTION 65"

REAR COVER

6. Release top row hooks. (Qty: 7)

- ① Tilt the Rear Cover and push upwards on the left or right side.
- ② Lift the Rear Cover off from the center.

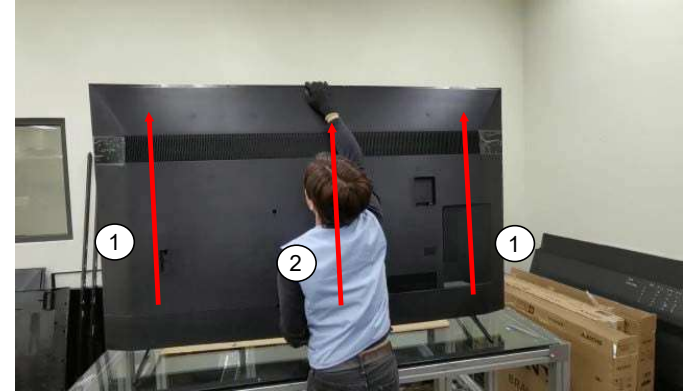

Hook positioning.

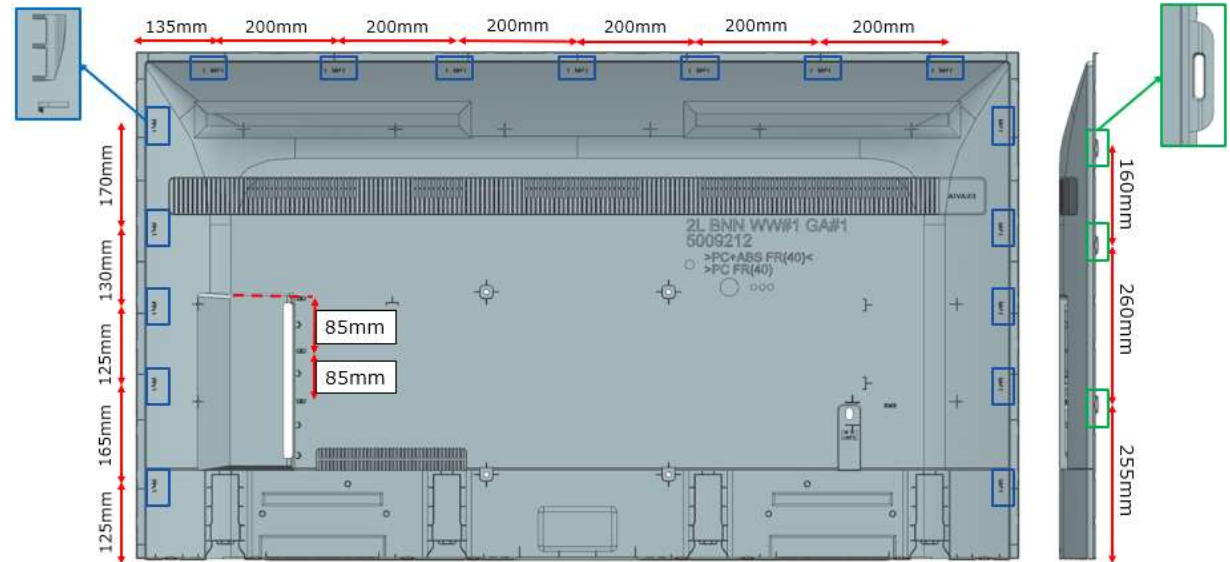

EXPLODED VIEW AND PART LIST 65"

• Place the TV set facing downwards on a stable, level surface before disassembly and assembly of parts.

•  and shaded parts are critical for safety. Replace only with part number specified.

•  Parts contain confidential information. Strictly follow the instruction whenever the components are repaired and/or replaced

\ (*) Parts are not stocked since they are seldom required for routine service. Some delays should be anticipated when ordering these components.

\ Picture provided in this section might have slight difference from the actual sets.



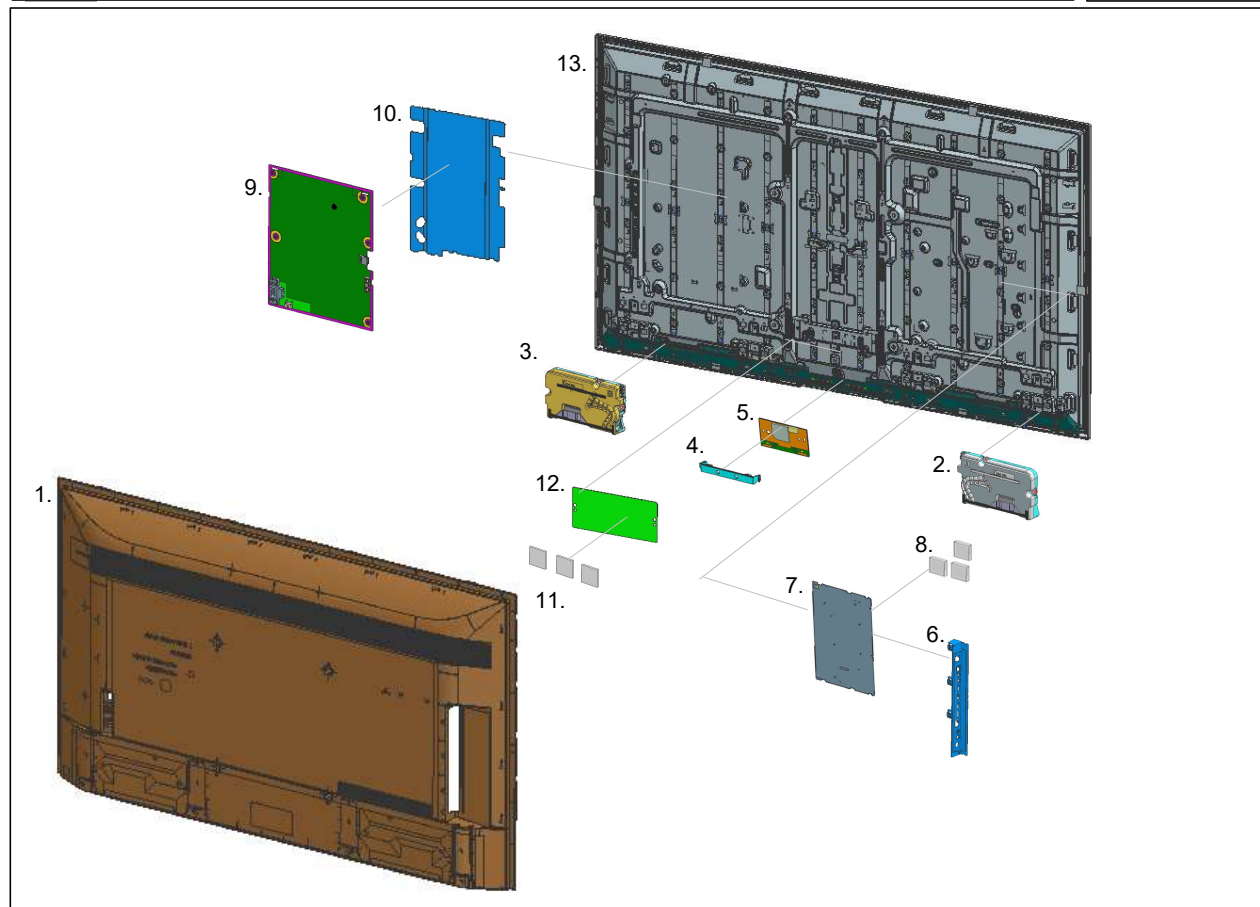

\ The reference number beside the part indicates the disassembly sequence.

\ Remove screws before disassembly. Unplug connectors before disassembly





EXPLODED VIEW AND PART LIST 65”

SET PART LIST

REF. NO	PART NO.	DESCRIPTION	REMARKS
 7	A-5057-156-A	COMPL_SVC_BM5A23_TKB_TXB_WW	Printed Circuit Board, incl. capacitors
 9	1-010-150-21	GL15P-STATIC CONVERTER (TV)	35L (Internal Power Supply)
 9	1-013-509-22	GL24P-STATIC CONVERTER (TV)	40L (Internal Power Supply)
 13	A-5061-765-A	P-MOD (YS DM065ENO01)(SVC)	35L (Liquid Crystal Display)
 13	A-5061-767-A	P-MOD (YS DM065INO01) (SVC)	40L (Liquid Crystal Display)

OTHERS PART

 1-005-634-21	C7L AC POWER CORD SETS (EU)	Cable
 1-005-641-12	C7L AC POWER CORD SETS (UK)	Cable

EXPLODED VIEW AND PART LIST 65"

CONNECTOR

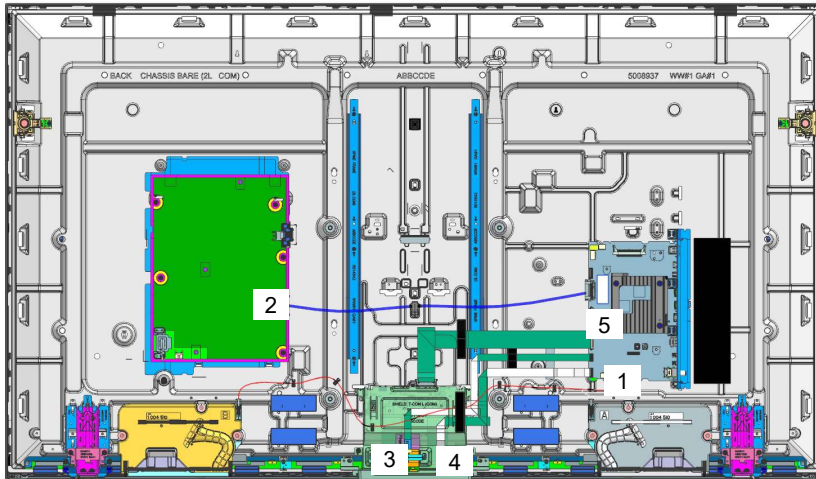

REF. NO	PART NO.	DESCRIPTION	REMARKS
1	1-006-513-44	CONNECTOR ASSY 4P (SP)	CN3550(B)-SP(1)
2	1-006-502-23	CONNECTOR ASSY 30P	CN1701(B)-CN6401(G)(1)
3	1-006-506-11	FLEXIBLE FLAT CABLE 20P	CN3801(B)-J1(WIFI/BT)(1)
4	1-006-509-12	FLEXIBLE FLAT CABLE 25P	CN1200(B)-CN102(H)(1)
5	1-010-543-21	FLEXIBLE FLAT CABLE 51P	CN4200(B)-U1(T-CON)(1)
6	1-014-423-11	FLEXIBLE FLAT CABLE 68P	SOURCE BOARD- T-CON(2)

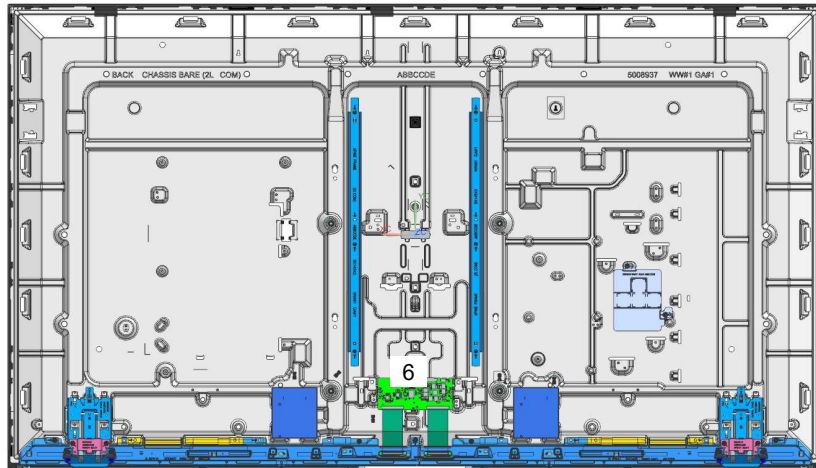

DISASSEMBLY AND REMOVAL CAUTION 75"

REAR COVER

1. Remove screw from Rear & Ac cover. (Qty: 5)

○ SCREW, +PSW M5X14

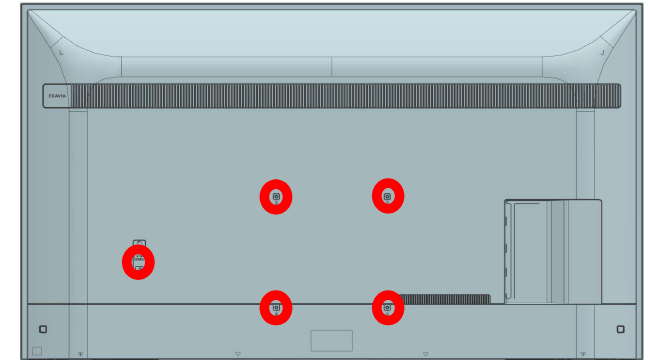

2. Release bottom hook (Qty: 8)

① Unhook two hooks which is closest to center simultaneously to prevent lock back.

② Locate both hooks and use coin or jig to unhook.

③ Can use mirror to assist locating the hook position.

④ Wrap coin in tape. (55mm x 25mm)

⑤ Thickness of coin approximately 2mm.

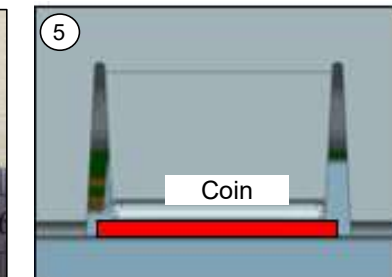
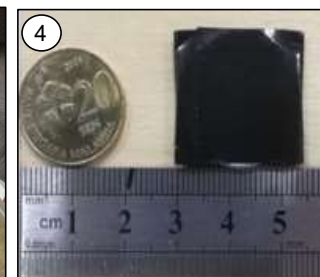
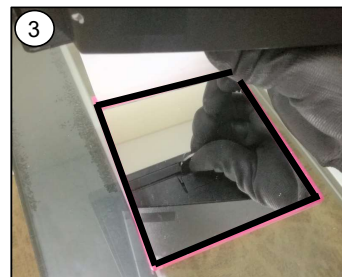
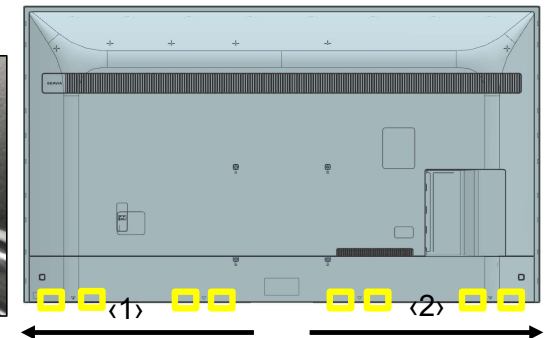
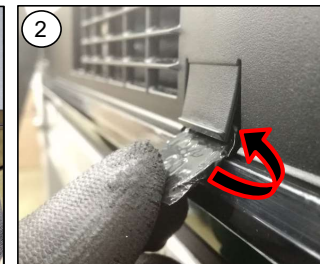

Note:
Refer to next page for the location of hooks
□ = Btm Back Chassis-Bezel Hook

DISASSEMBLY AND REMOVAL CAUTION 75"

REAR COVER

2. Bottom hook position.

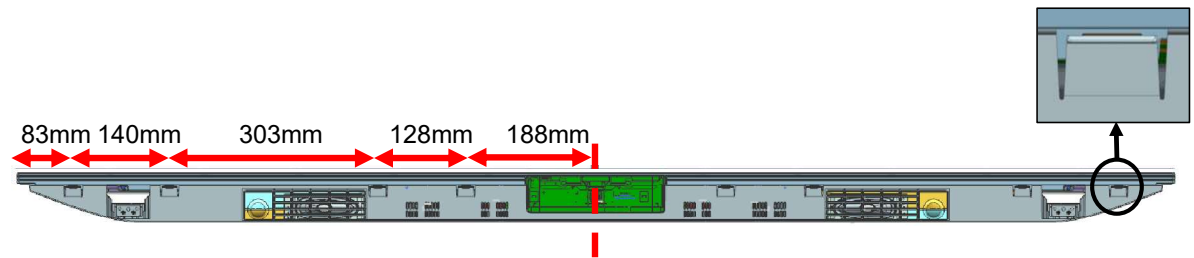

3. Release corner hook (Qty: 2)

- ① When releasing hook, pull the Rear Cover corner and insert jig.
- ② Ensure that the jig is pulled backward.
- ③ DO NOT pivot on Bezel when inserting jig.

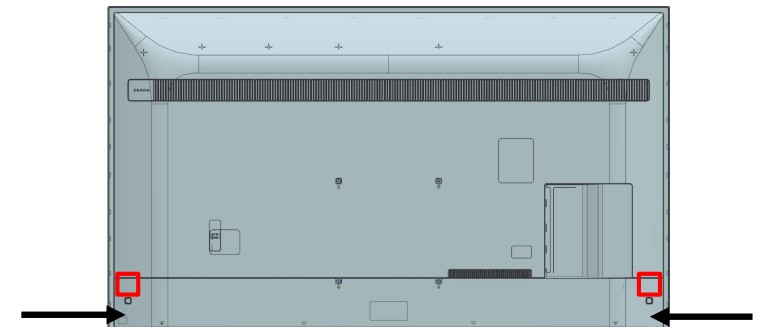

Note:

- 1) Ruler or jig to release corner hook.
- 2) Wrap ruler with tape to prevent scratch

□ =Back Chassis-Rear Cover Hook

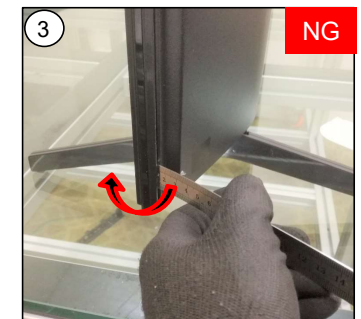
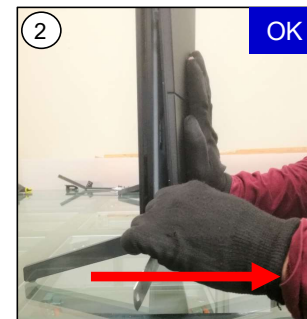



DISASSEMBLY AND REMOVAL CAUTION 75"

REAR COVER

4. Remove left side hook. (Qty: 2)

- ① Grip Rear Cover with hand and unhook Rear Cover – Bezel hook using ruler or jig
- ② Flex the Rear cover outwards to unhook. Support set with arm.

Note:

-  Back Chassis-Rear Cover Hook
-  Rear Cover-Bezel Hook

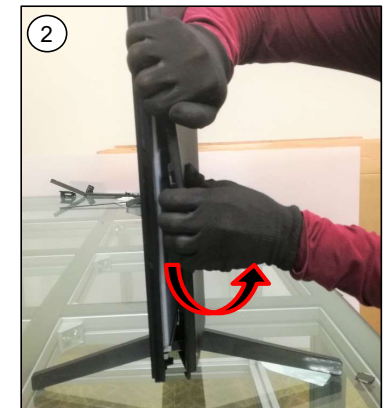
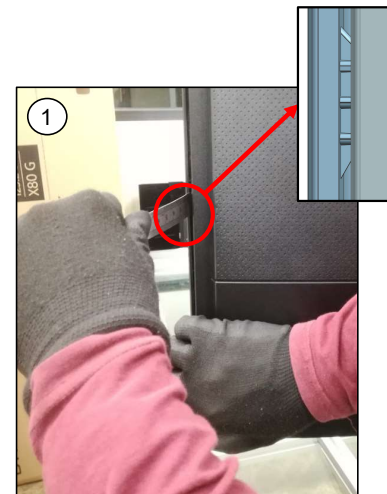
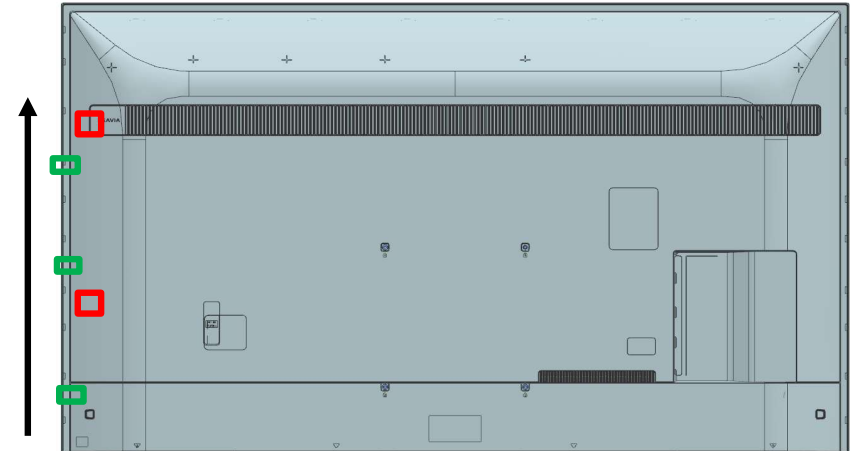



DISASSEMBLY AND REMOVAL CAUTION 75"

REAR COVER

5. Remove right side hook. (Qty: 2)

- ① Unhook side hooks ①
- ② Pull Rear Cover below the Side Jack to release the hooks ②
- ③ Proceed to unhook remaining side hooks ③

Note:

-  Back Chassis-Rear Cover Hook
-  Rear Cover-Bezel Hook
-  SJB hook

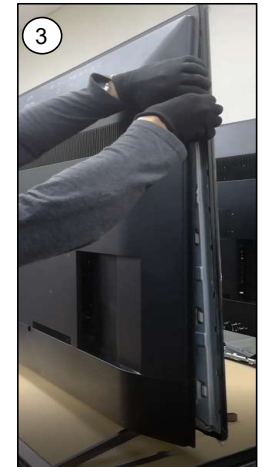
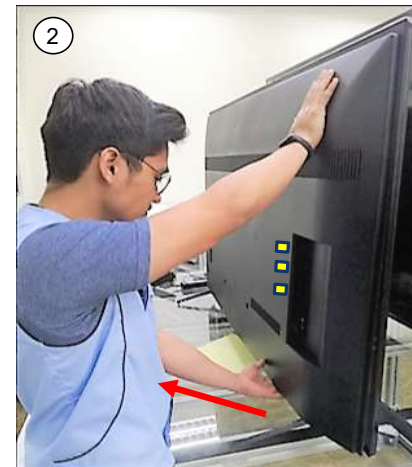
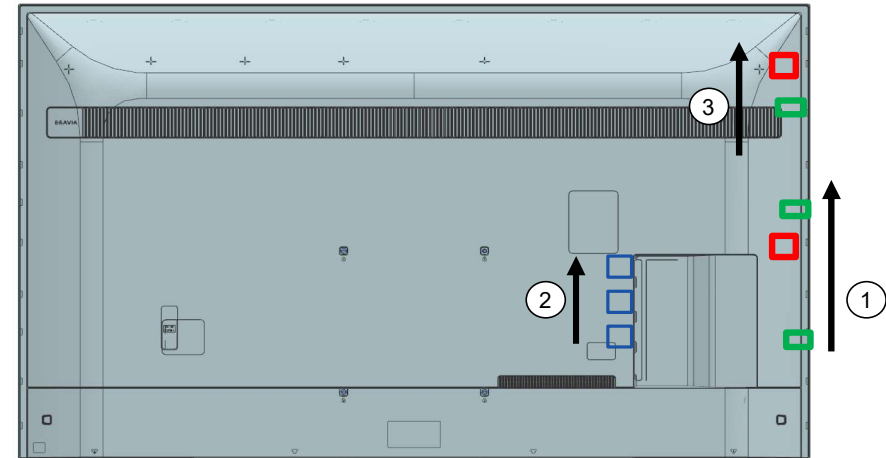

DISASSEMBLY AND REMOVAL CAUTION 75"

REAR COVER

6. Release top row hooks. (Qty: 8)

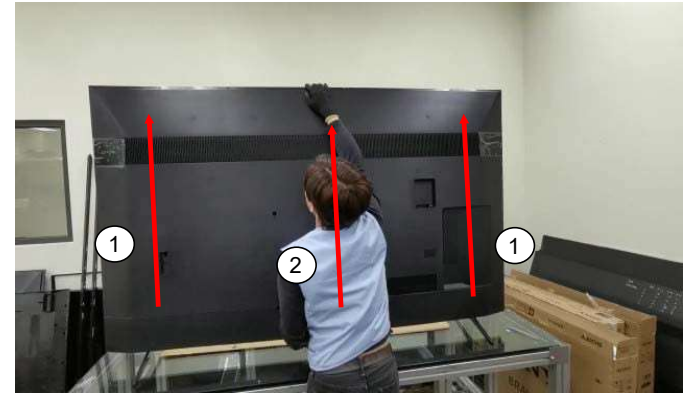

- ① Tilt the Rear Cover and push upwards on the left or right side.
- ② Lift the Rear Cover off from the center.



Hook positioning.



EXPLODED VIEW AND PART LIST 75"



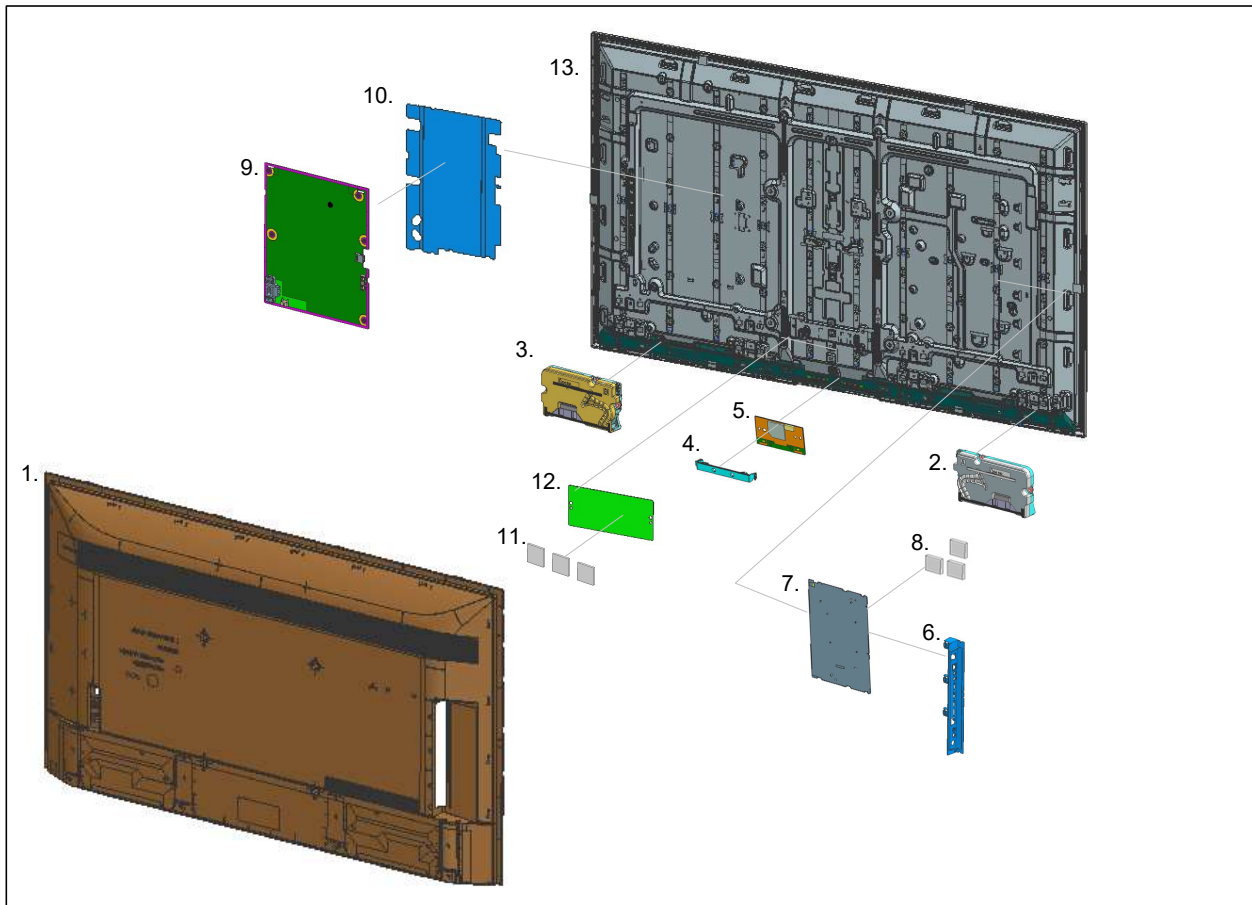

- Place the TV set facing downwards on a stable, level surface before disassembly and assembly of parts.
-  and shaded parts are critical for safety. Replace only with part number specified.
-  Parts contain confidential information. Strictly follow the instruction whenever the components are repaired and/or replaced

- \ (*) Parts are not stocked since they are seldom required for routine service. Some delays should be anticipated when ordering these components.
- \ Picture provided in this section might have slight difference from the actual sets.
- \ The reference number beside the part indicates the disassembly sequence.
- \ Remove screws before disassembly. Unplug connectors before disassembly



EXPLODED VIEW AND PART LIST 75”

SET PART LIST

REF. NO	PART NO.	DESCRIPTION	REMARKS
 7	A-5057-156-A	COMPL_SVC_BM5A23_TKB_TXB_WW	Printed Circuit Board, incl. capacitors
 9	1-009-802-41	GL14BP-STATIC CONVERTER (TV)	Internal Power Supply
 13	A-5061-749-A	P-MOD (YS DM075ENO02)	35L (Liquid Crystal Display)
 13	A-5060-075-A	P-MOD (YS DM075INO02)	40L (Liquid Crystal Display)

OTHERS PART

 1-005-621-21	C7L AC POWER CORD SETS (EU)	Cable
 1-005-628-13	C7L AC POWER CORD SETS (UK)	Cable

EXPLODED VIEW AND PART LIST 75"

CONNECTOR

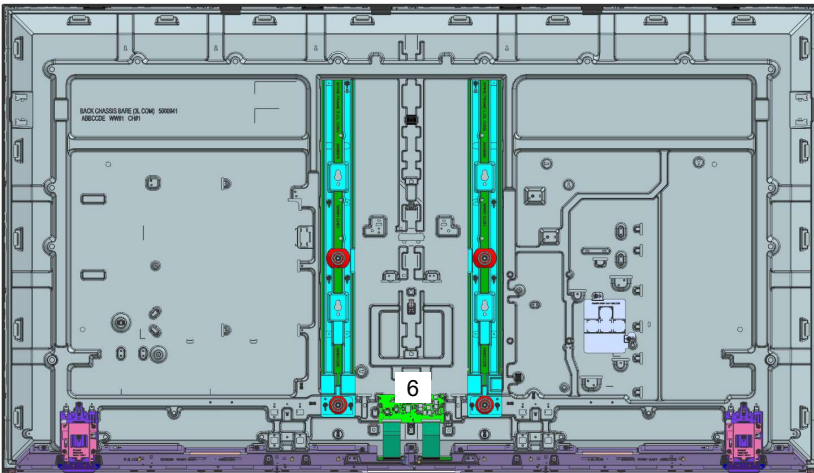
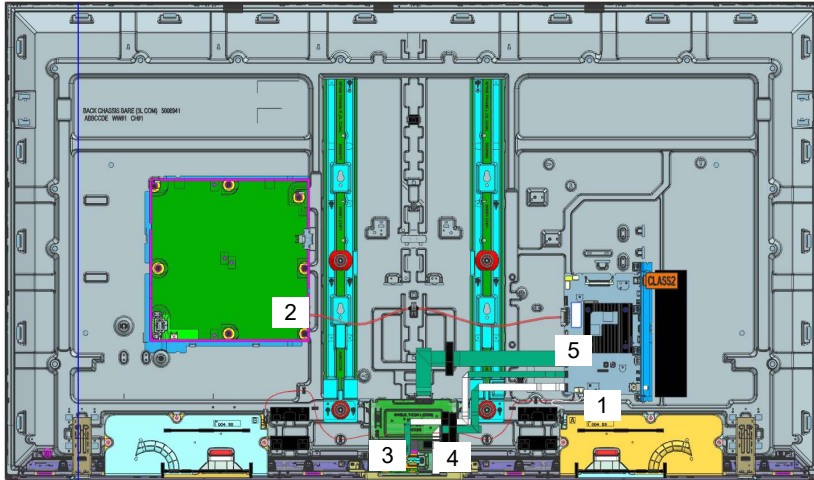

REF. NO	PART NO.	DESCRIPTION	REMARKS
1	1-006-514-13	CONNECTOR ASSY 4P (SP)	CN3550(B)-SP(1)
2	1-006-502-11	CONNECTOR ASSY 30P	CN1701(B)-CN6401(G)(1)
3	1-006-505-12	FLEXIBLE FLAT CABLE 20P	CN3801(B)-J1(WIFI/BT)(1)
4	1-006-510-12	FLEXIBLE FLAT CABLE 25P	CN1200(B)-CN102(H)(1)
5	1-010-543-21	FLEXIBLE FLAT CABLE 51P	CN4200(B)-U1(T-CON)(1)
6	1-014-427-11	FLEXIBLE FLAT CABLE 68P	SOURCE BOARD- T-CON(2)

DISASSEMBLY AND REMOVAL CAUTION 85"

REAR COVER

1. Remove screw from Rear & Ac cover. (Qty: 5)

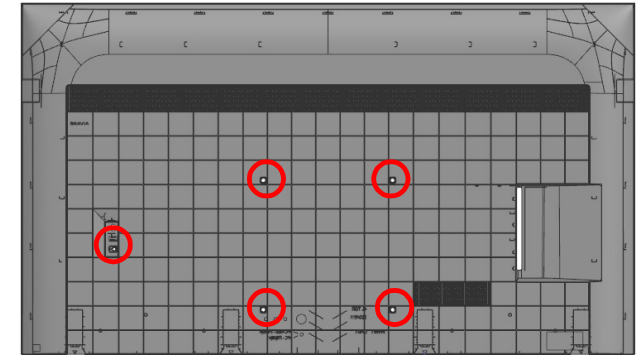

2. Release bottom hook (Qty: 8)

① Unhook two hooks which is closest to center simultaneously to prevent lock back.

② Locate both hooks and use coin or jig to unhook.

③ Can use mirror to assist locating the hook position.

④ Wrap coin in tape. (55mm x 25mm)

⑤ Thickness of coin approximately 2mm.

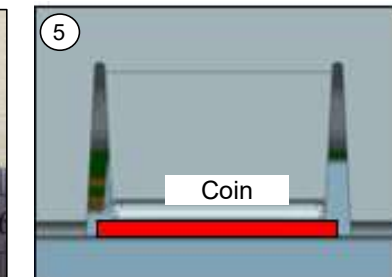
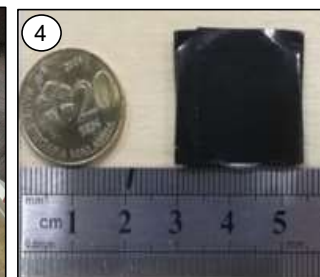
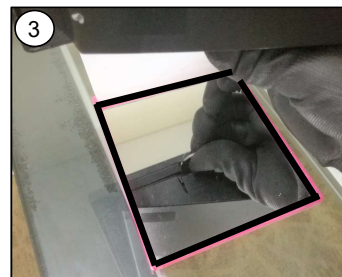
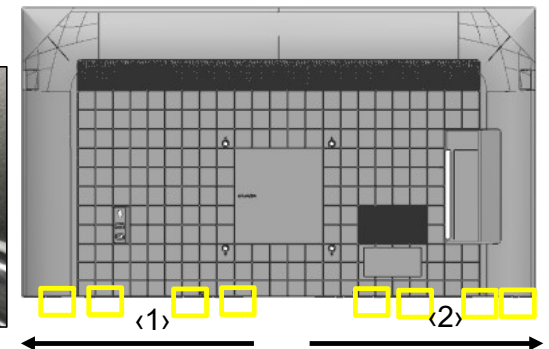
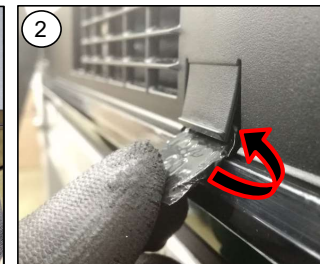

Note:
Refer to next page for the location of hooks
☐ = Btm Back Chassis-Bezel Hook

DISASSEMBLY AND REMOVAL CAUTION 85"

REAR COVER

2. Bottom hook position.

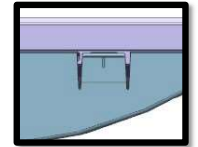

3. Release corner hook (Qty: 2)

- ① When releasing hook, pull the Rear Cover corner and insert jig.
- ② Ensure that the jig is pulled backward.
- ③ DO NOT pivot on Bezel when inserting jig.

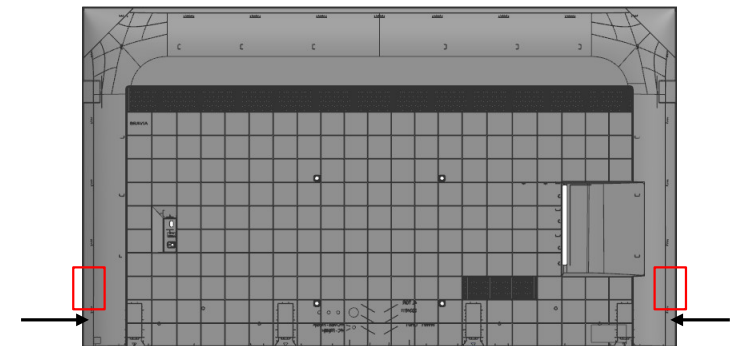

Note:

- 1) Ruler or jig to release corner hook.
- 2) Wrap ruler with tape to prevent scratch

☐ =Back Chassis-Rear Cover Hook

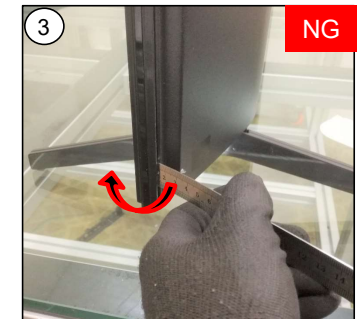
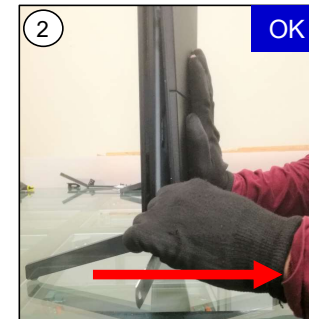



DISASSEMBLY AND REMOVAL CAUTION 85"

REAR COVER

4. Remove left side hook. (Qty: 5)

- ① Grip Rear Cover with hand and unhook Rear Cover – Bezel hook using ruler or jig
- ② Flex the Rear cover outwards to unhook. Support set with arm.

Note:

-  Back Chassis-Rear Cover Hook
-  Rear Cover-Bezel Hook

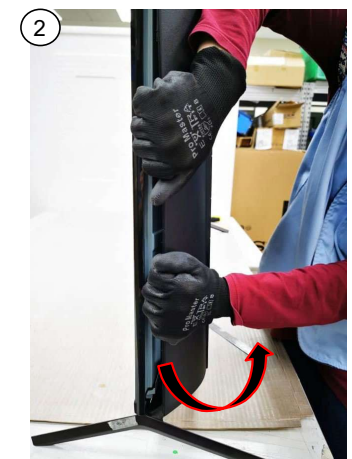
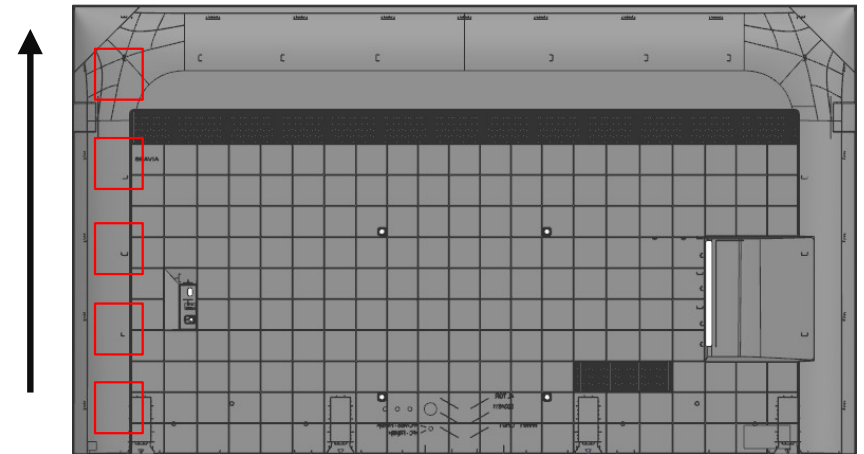



DISASSEMBLY AND REMOVAL CAUTION 85"

REAR COVER

5. Remove right side hook. (Qty: 5)

- ① Unhook side hooks ①
- ② Pull Rear Cover below the Side Jack to release the hooks ②
- ③ Proceed to unhook remaining side hooks ③

Note:

-  Back Chassis-Rear Cover Hook
-  Rear Cover-Bezel Hook
-  SJB hook

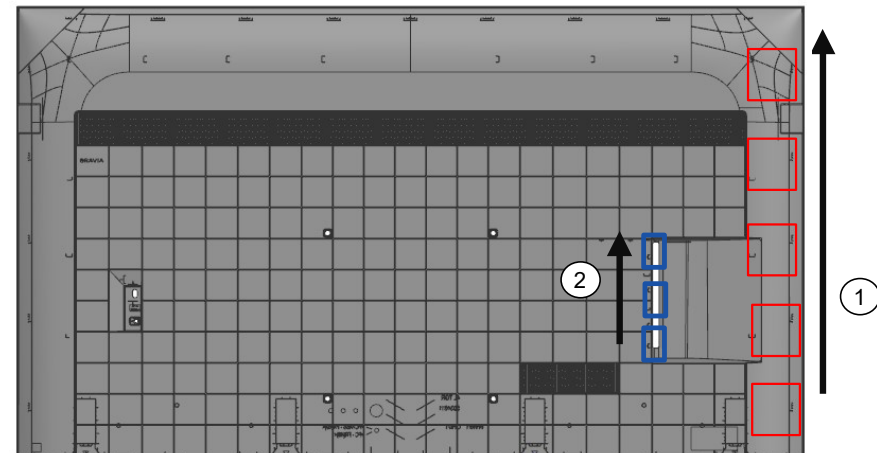

DISASSEMBLY AND REMOVAL CAUTION 85"

REAR COVER

6. Release top row hooks. (Qty: 9)

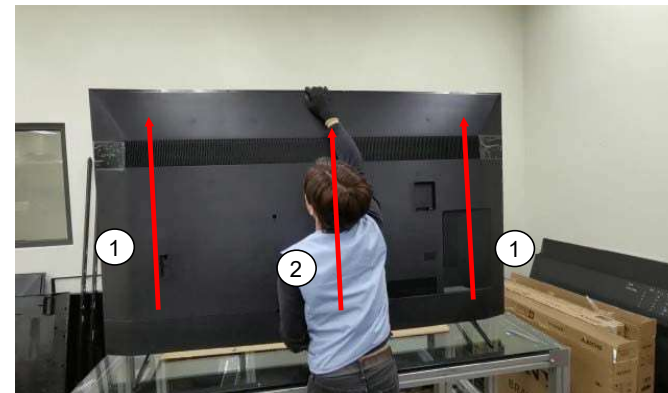

- ① Tilt the Rear Cover and push upwards on the left or right side.
- ② Lift the Rear Cover off from the center.

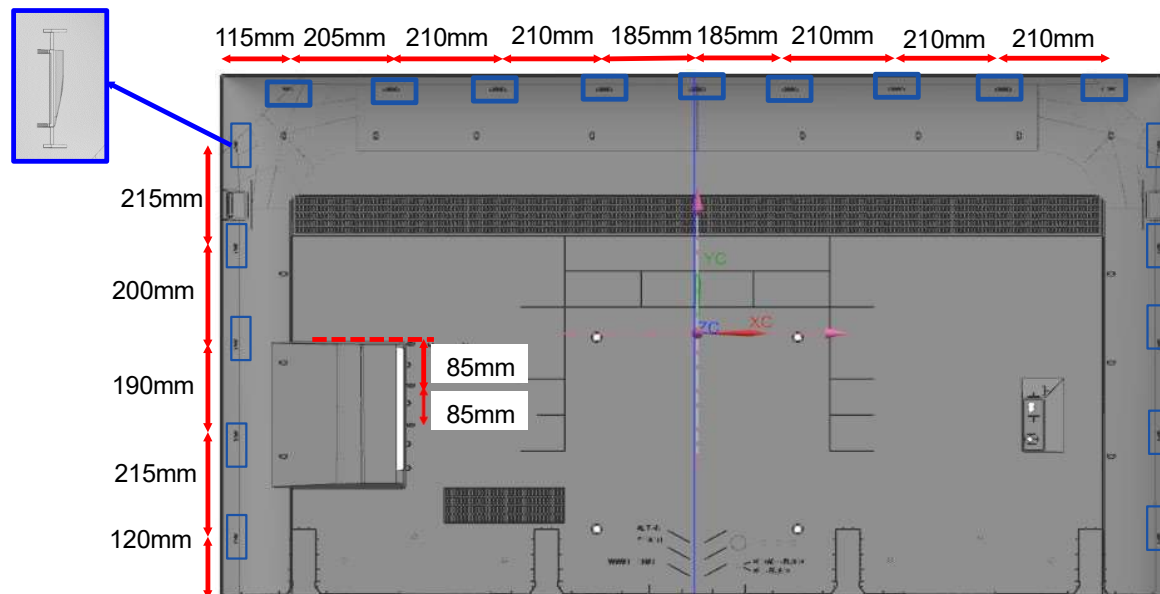

Hook positioning.



EXPLODED VIEW AND PART LIST 85"

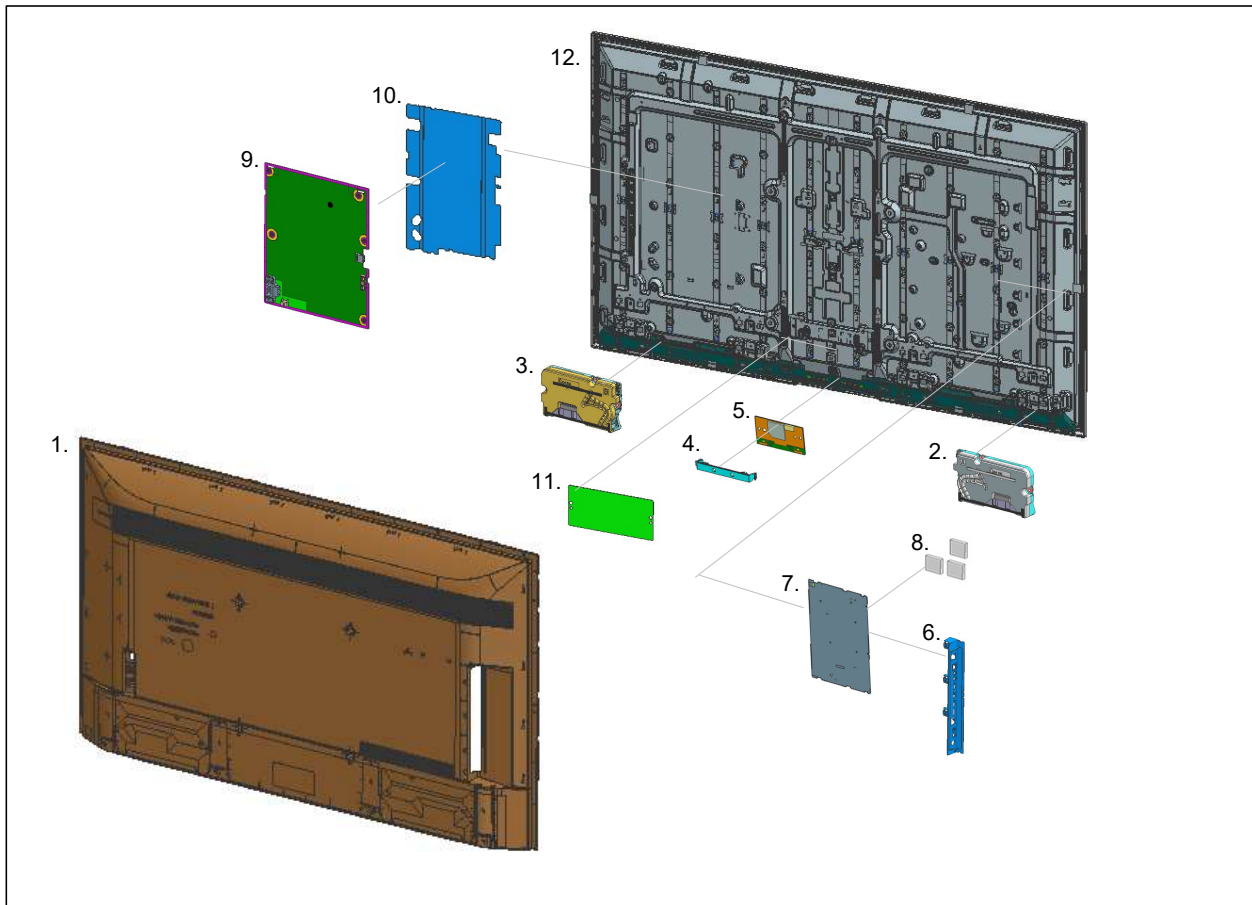

- Place the TV set facing downwards on a stable, level surface before disassembly and assembly of parts.
-  and shaded parts are critical for safety. Replace only with part number specified.
-  Parts contain confidential information. Strictly follow the instruction whenever the components are repaired and/or replaced

- \ (*) Parts are not stocked since they are seldom required for routine service. Some delays should be anticipated when ordering these components.
- \ Picture provided in this section might have slight difference from the actual sets.
- \ The reference number beside the part indicates the disassembly sequence.
- \ Remove screws before disassembly. Unplug connectors before disassembly



EXPLODED VIEW AND PART LIST 85”

SET PART LIST

REF. NO	PART NO.	DESCRIPTION	REMARKS
 7	A-5057-156-A	COMPL_SVC_BM5A23_TKB_TXB_WW	Printed Circuit Board, incl. capacitors
 9	1-004-424-61	GL03CP-STATIC CONVERTER (TV)	Internal Power Supply
 12	A-5061-769-A	P-MOD (YS DM085ENU02)	35L (Liquid Crystal Display)
12	A-5060-073-A	P-MOD (YS DM085INU02)	40L (Liquid Crystal Display)

OTHERS PART

 1-005-621-21	C7L AC POWER CORD SETS (EU)	Cable
 1-005-628-13	C7L AC POWER CORD SETS (UK)	Cable

EXPLODED VIEW AND PART LIST 85"

CONNECTOR

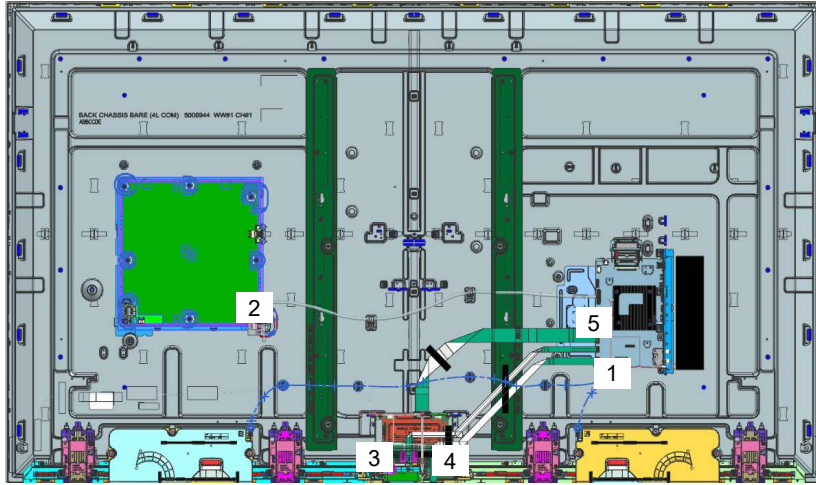

REF. NO	PART NO.	DESCRIPTION	REMARKS
1	1-006-517-11	CONNECTOR ASSY 4P (SP)	CN3550(B)-SP(1)
2	1-006-518-11	CONNECTOR ASSY 30P	CN1701(B)-CN6401(G)(1)
3	1-006-522-11	FLEXIBLE FLAT CABLE 20P	CN3801(B)-J1(WIFI/BT)(1)
4	1-011-605-11	FLEXIBLE FLAT CABLE 25P	CN1200(B)-CN102(H)(1)
5	1-006-519-11	FLEXIBLE FLAT CABLE 51P	CN4200(B)-U1(T-CON)(1)
6	1-017-273-11	FLEXIBLE FLAT CABLE 96P	SOURCE BOARD- T-CON(1)

