

Precision 3260 Compact

Service Manual

Notes, cautions, and warnings

 **NOTE:** A NOTE indicates important information that helps you make better use of your product.

 **CAUTION:** A CAUTION indicates either potential damage to hardware or loss of data and tells you how to avoid the problem.

 **WARNING:** A WARNING indicates a potential for property damage, personal injury, or death.

Chapter 1: Working inside your computer	6
Safety instructions.....	6
Before working inside your computer.....	6
Safety precautions.....	7
Electrostatic discharge—ESD protection.....	7
ESD field service kit	8
Transporting sensitive components.....	9
After working inside your computer.....	9
BitLocker.....	9
Chapter 2: Removing and installing components	10
Recommended tools.....	10
Screw list.....	10
Major components of Precision 3260 Compact.....	11
Side cover.....	13
Removing the side cover.....	13
Installing the side cover.....	15
2.5-inch hard drive.....	17
Removing the 2.5-inch hard-drive assembly.....	17
Removing the 2.5-inch hard-drive caddy.....	18
Installing the 2.5-inch hard-drive caddy.....	19
Installing the 2.5-inch hard-drive assembly.....	20
Riser card.....	21
Removing the riser card.....	21
Installing the riser card.....	23
Wireless card.....	24
Removing the wireless card.....	24
Installing the wireless card.....	26
Speaker.....	27
Removing the speaker.....	27
Installing the speaker.....	28
Processor fan.....	29
Removing the processor fan.....	29
Installing the processor fan.....	30
Memory module.....	32
Removing the memory modules.....	32
Installing the memory modules.....	33
M.2 solid-state drive.....	34
Removing the M.2 2230 PCIe solid-state drive (slot-1).....	34
Installing the M.2 2230 PCIe solid-state drive (slot-1).....	35
Removing the M.2 2280 PCIe solid-state drive (slot-1).....	36
Installing the M.2 2280 PCIe solid-state drive (slot-1).....	37
Removing the M.2 2230 PCIe solid-state drive (slot-0).....	38
Installing the M.2 2230 PCIe solid-state drive (slot-0).....	38











Removing the M.2 2280 PCIe solid-state drive (slot-0).....	39
Installing the M.2 2280 PCIe solid-state drive (slot-0).....	40
Expansion card.....	41
Removing the serial port PCIe card.....	41
Installing the serial port PCIe card.....	42
Removing the graphics card.....	43
Installing the graphics card.....	44
Optional I/O module.....	46
Removing the optional I/O module.....	46
Installing the optional I/O module.....	47
Coin-cell battery.....	48
Removing the coin-cell battery.....	48
Installing the coin-cell battery.....	49
Heat sink.....	50
Removing the heat sink.....	50
Installing the heat sink.....	52
SATA FFC module.....	54
Removing the SATA FFC module.....	54
Installing the SATA FFC module.....	54
Processor.....	55
Removing the processor.....	55
Installing the processor.....	57
System board.....	58
Removing the system board.....	58
Installing the system board.....	61
Internal antennae.....	65
Removing the internal antenna—location 1.....	65
Installing the internal antenna—location 1.....	66
Removing the internal antenna—location 2.....	67
Installing the internal antenna—location 2.....	68
Removing the SMA antenna—Location 3.....	69
Installing the SMA antenna—Location 3.....	71
Chapter 3: Drivers and downloads.....	73
Chapter 4: BIOS setup.....	74
Entering BIOS setup program.....	74
Navigation keys.....	74
One time boot menu.....	74
System setup options.....	75
Updating the BIOS.....	84
Updating the BIOS in Windows.....	84
Updating the BIOS in Linux and Ubuntu.....	84
Updating the BIOS using the USB drive in Windows.....	84
Updating the BIOS from the F12 One-Time boot menu.....	85
System and setup password.....	85
Assigning a system setup password.....	86
Deleting or changing an existing system setup password.....	86
Clearing CMOS settings.....	87

Clearing BIOS (System Setup) and System passwords.....	87
Chapter 5: Troubleshooting.....	88
Dell SupportAssist Pre-boot System Performance Check diagnostics.....	88
Running the SupportAssist Pre-Boot System Performance Check.....	88
System-diagnostic lights.....	88
Recovering the operating system.....	90
Real Time Clock—RTC reset.....	90
Backup media and recovery options.....	91
WiFi power cycle.....	91
System limitations.....	91
Chapter 6: Getting help and contacting Dell.....	93

Working inside your computer

Safety instructions

Use the following safety guidelines to protect your computer from potential damage and to ensure your personal safety. Unless otherwise noted, each procedure included in this document assumes that you have read the safety information that shipped with your computer.

-  **WARNING:** Before working inside your computer, read the safety information that is shipped with your computer. For more safety best practices, see the Regulatory Compliance home page at www.dell.com/regulatory_compliance.
-  **WARNING:** Disconnect your computer from all power sources before opening the computer cover or panels. After you finish working inside the computer, replace all covers, panels, and screws before connecting your computer to an electrical outlet.
-  **CAUTION:** To avoid damaging the computer, ensure that the work surface is flat, dry, and clean.
-  **CAUTION:** To avoid damaging the components and cards, handle them by their edges, and avoid touching the pins and the contacts.
-  **CAUTION:** You should only perform troubleshooting and repairs as authorized or directed by the Dell technical assistance team. Damage due to servicing that is not authorized by Dell is not covered by your warranty. See the safety instructions that is shipped with the product or at www.dell.com/regulatory_compliance.
-  **CAUTION:** Before touching anything inside your computer, ground yourself by touching an unpainted metal surface, such as the metal at the back of the computer. While you work, periodically touch an unpainted metal surface to dissipate static electricity which could harm internal components.
-  **CAUTION:** When you disconnect a cable, pull it by its connector or its pull tab, not the cable itself. Some cables have connectors with locking tabs or thumbscrews that you must disengage before disconnecting the cable. When disconnecting cables, keep them evenly aligned to avoid bending the connector pins. When connecting cables, ensure that the ports and the connectors are correctly oriented and aligned.
-  **CAUTION:** Press and eject any installed card from the media-card reader.
-  **CAUTION:** Exercise caution when handling Lithium-ion batteries in laptops. Swollen batteries should not be used and should be replaced and disposed properly.
-  **NOTE:** The color of your computer and certain components may appear differently than shown in this document.

Before working inside your computer

About this task

-  **NOTE:** The images in this document may differ from your computer depending on the configuration you ordered.

Steps

1. Save and close all open files and exit all open applications.
2. Shut down your computer. Click **Start** >  **Power** > **Shut down**.

 **NOTE:** If you are using a different operating system, see the documentation of your operating system for shut-down instructions.

3. Disconnect your computer and all attached devices from their electrical outlets.
4. Disconnect all attached network devices and peripherals, such as keyboard, mouse, and monitor from your computer.

 **CAUTION:** To disconnect a network cable, first unplug the cable from your computer and then unplug the cable from the network device.

5. Remove any media card and optical disc from your computer, if applicable.

Safety precautions

The safety precautions chapter details the primary steps to be taken before performing any disassembly instructions.

Observe the following safety precautions before you perform any installation or break/fix procedures involving disassembly or reassembly:

- Turn off the system and all attached peripherals.
- Disconnect the system and all attached peripherals from AC power.
- Disconnect all network cables, telephone, and telecommunications lines from the system.
- Use an ESD field service kit when working inside any tablet/notebook/desktop to avoid electrostatic discharge (ESD) damage.
- After removing any system component, carefully place the removed component on an anti-static mat.
- Wear shoes with non-conductive rubber soles to reduce the chance of getting electrocuted.

Standby power

Dell products with standby power must be unplugged before you open the case. Systems that incorporate standby power are essentially powered while turned off. The internal power enables the system to be remotely turned on (wake on LAN) and suspended into a sleep mode and has other advanced power management features.

Unplugging, pressing and holding the power button for 15 seconds should discharge residual power in the system board.

Bonding

Bonding is a method for connecting two or more grounding conductors to the same electrical potential. This is done through the use of a field service electrostatic discharge (ESD) kit. When connecting a bonding wire, ensure that it is connected to bare metal and never to a painted or non-metal surface. The wrist strap should be secure and in full contact with your skin, and ensure that you remove all jewelry such as watches, bracelets, or rings prior to bonding yourself and the equipment.

Electrostatic discharge—ESD protection

ESD is a major concern when you handle electronic components, especially sensitive components such as expansion cards, processors, memory DIMMs, and system boards. Very slight charges can damage circuits in ways that may not be obvious, such as intermittent problems or a shortened product life span. As the industry pushes for lower power requirements and increased density, ESD protection is an increasing concern.

Due to the increased density of semiconductors used in recent Dell products, the sensitivity to static damage is now higher than in previous Dell products. For this reason, some previously approved methods of handling parts are no longer applicable.

Two recognized types of ESD damage are catastrophic and intermittent failures.

- **Catastrophic** – Catastrophic failures represent approximately 20 percent of ESD-related failures. The damage causes an immediate and complete loss of device functionality. An example of catastrophic failure is a memory DIMM that has received a static shock and immediately generates a "No POST/No Video" symptom with a beep code emitted for missing or nonfunctional memory.
- **Intermittent** – Intermittent failures represent approximately 80 percent of ESD-related failures. The high rate of intermittent failures means that most of the time when damage occurs, it is not immediately recognizable. The DIMM receives a static shock, but the tracing is merely weakened and does not immediately produce outward symptoms related to the damage. The weakened trace may take weeks or months to melt, and in the meantime may cause degradation of memory integrity, intermittent memory errors, etc.

The more difficult type of damage to recognize and troubleshoot is the intermittent (also called latent or "walking wounded") failure.

Perform the following steps to prevent ESD damage:

- Use a wired ESD wrist strap that is properly grounded. The use of wireless anti-static straps is no longer allowed; they do not provide adequate protection. Touching the chassis before handling parts does not ensure adequate ESD protection on parts with increased sensitivity to ESD damage.
- Handle all static-sensitive components in a static-safe area. If possible, use anti-static floor pads and workbench pads.
- When unpacking a static-sensitive component from its shipping carton, do not remove the component from the anti-static packing material until you are ready to install the component. Before unwrapping the anti-static packaging, ensure that you discharge static electricity from your body.
- Before transporting a static-sensitive component, place it in an anti-static container or packaging.

ESD field service kit

The unmonitored Field Service kit is the most commonly used service kit. Each Field Service kit includes three main components: anti-static mat, wrist strap, and bonding wire.

Components of an ESD field service kit

The components of an ESD field service kit are:

- **Anti-Static Mat** – The anti-static mat is dissipative and parts can be placed on it during service procedures. When using an anti-static mat, your wrist strap should be snug and the bonding wire should be connected to the mat and to any bare metal on the system being worked on. Once deployed properly, service parts can be removed from the ESD bag and placed directly on the mat. ESD-sensitive items are safe in your hand, on the ESD mat, in the system, or inside a bag.
- **Wrist Strap and Bonding Wire** – The wrist strap and bonding wire can be either directly connected between your wrist and bare metal on the hardware if the ESD mat is not required, or connected to the anti-static mat to protect hardware that is temporarily placed on the mat. The physical connection of the wrist strap and bonding wire between your skin, the ESD mat, and the hardware is known as bonding. Use only Field Service kits with a wrist strap, mat, and bonding wire. Never use wireless wrist straps. Always be aware that the internal wires of a wrist strap are prone to damage from normal wear and tear, and must be checked regularly with a wrist strap tester in order to avoid accidental ESD hardware damage. It is recommended to test the wrist strap and bonding wire at least once per week.
- **ESD Wrist Strap Tester** – The wires inside of an ESD strap are prone to damage over time. When using an unmonitored kit, it is a best practice to regularly test the strap prior to each service call, and at a minimum, test once per week. A wrist strap tester is the best method for doing this test. If you do not have your own wrist strap tester, check with your regional office to find out if they have one. To perform the test, plug the wrist-strap's bonding-wire into the tester while it is strapped to your wrist and push the button to test. A green LED is lit if the test is successful; a red LED is lit and an alarm sounds if the test fails.
- **Insulator Elements** – It is critical to keep ESD sensitive devices, such as plastic heat sink casings, away from internal parts that are insulators and often highly charged.
- **Working Environment** – Before deploying the ESD Field Service kit, assess the situation at the customer location. For example, deploying the kit for a server environment is different than for a desktop or portable environment. Servers are typically installed in a rack within a data center; desktops or portables are typically placed on office desks or cubicles. Always look for a large open flat work area that is free of clutter and large enough to deploy the ESD kit with additional space to accommodate the type of system that is being repaired. The workspace should also be free of insulators that can cause an ESD event. On the work area, insulators such as Styrofoam and other plastics should always be moved at least 12 inches or 30 centimeters away from sensitive parts before physically handling any hardware components.
- **ESD Packaging** – All ESD-sensitive devices must be shipped and received in static-safe packaging. Metal, static-shielded bags are preferred. However, you should always return the damaged part using the same ESD bag and packaging that the new part arrived in. The ESD bag should be folded over and taped shut and all the same foam packing material should be used in the original box that the new part arrived in. ESD-sensitive devices should be removed from packaging only at an ESD-protected work surface, and parts should never be placed on top of the ESD bag because only the inside of the bag is shielded. Always place parts in your hand, on the ESD mat, in the system, or inside an anti-static bag.
- **Transporting Sensitive Components** – When transporting ESD sensitive components such as replacement parts or parts to be returned to Dell, it is critical to place these parts in anti-static bags for safe transport.

ESD protection summary

It is recommended that all field service technicians use the traditional wired ESD grounding wrist strap and protective anti-static mat at all times when servicing Dell products. In addition, it is critical that technicians keep sensitive parts separate from all insulator parts while performing service and that they use anti-static bags for transporting sensitive components.

Transporting sensitive components

When transporting ESD sensitive components such as replacement parts or parts to be returned to Dell, it is critical to place these parts in anti-static bags for safe transport.

Lifting equipment

Adhere to the following guidelines when lifting heavy weight equipment:

 **CAUTION: Do not lift greater than 50 pounds. Always obtain additional resources or use a mechanical lifting device.**

1. Get a firm balanced footing. Keep your feet apart for a stable base, and point your toes out.
2. Tighten stomach muscles. Abdominal muscles support your spine when you lift, offsetting the force of the load.
3. Lift with your legs, not your back.
4. Keep the load close. The closer it is to your spine, the less force it exerts on your back.
5. Keep your back upright, whether lifting or setting down the load. Do not add the weight of your body to the load. Avoid twisting your body and back.
6. Follow the same techniques in reverse to set the load down.

After working inside your computer

About this task

 **CAUTION: Leaving stray or loose screws inside your computer may severely damage your computer.**

Steps

1. Replace all screws and ensure that no stray screws remain inside your computer.
2. Connect any external devices, peripherals, or cables you removed before working on your computer.
3. Replace any media cards, discs, or any other parts that you removed before working on your computer.
4. Connect your computer and all attached devices to their electrical outlets.
5. Turn on your computer.

BitLocker

 **CAUTION: If BitLocker is not suspended before updating the BIOS, the next time you reboot the system it will not recognize the BitLocker key. You will then be prompted to enter the recovery key to progress, and the system will ask for this on each reboot. If the recovery key is not known this can result in data loss or an unnecessary operating system reinstall. For more information about this subject, see Knowledge Article: [updating the BIOS on Dell systems with BitLocker enabled](#).**

The installation of the following components triggers BitLocker:

- Hard disk drive or solid state drive
- System board

Removing and installing components

NOTE: The images in this document may differ from your computer depending on the configuration you ordered.

Recommended tools

The procedures in this document may require the following tools:

- Phillips # 1 screwdriver
- Small flat blade screwdriver

Screw list

NOTE: When removing screws from a component, it is recommended to note the screw type, the quantity of screws, and then place them in a screw storage box. This is to ensure that the correct number of screws and correct screw type is restored when the component is replaced.

NOTE: Some computers have magnetic surfaces. Ensure that the screws are not left attached to such surfaces when replacing a component.

NOTE: Screw color may vary with the configuration ordered.

Table 1. Screw list









Component	Screw type	Quantity	Screw image
Side cover	#6-32 (Thumbscrew)	1	
Wireless card	M2x3	2	
M.2 2230/2280 Solid-state drive	M2x3.5	1+1 (for slot1 and slot2)	
Riser card bracket	M3x5	2	
Optional I/O modules	M3x3	2	
Heat sink	Captive screws	3	
System board	M3x4	5	

Table 1. Screw list (continued)

Component	Screw type	Quantity	Screw image
	M2x4	3	
Speaker holder	M3x4		
Internal antenna - Location 1 and Location 2	M3x3	2	
SATA FFC module	M3x5	1	

Major components of Precision 3260 Compact

The following image shows the major components of Precision 3260 Compact.

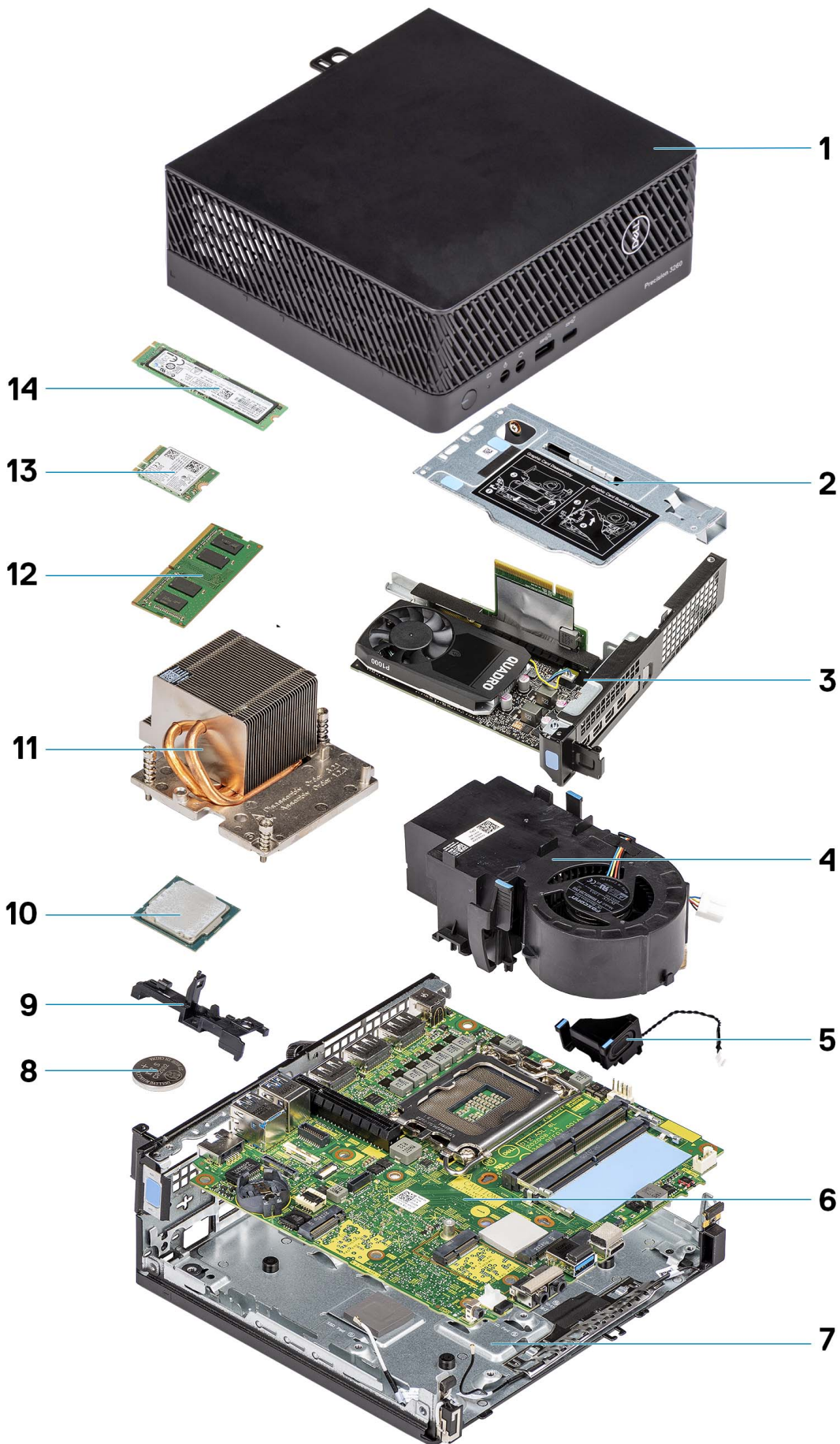

1. Side cover
2. Riser-card bracket
3. Graphics card
4. Processor fan
5. Speaker
6. System board
7. Bottom chassis
8. Coin-cell battery
9. Speaker holder
10. Processor
11. Heat sink
12. Memory module
13. Wireless card
14. solid-state drive

i **NOTE:** Dell provides a list of components and their part numbers for the original system configuration purchased. These parts are available according to warranty coverages purchased by the customer. Contact your Dell sales representative for purchase options.

Side cover

Removing the side cover

Prerequisites

1. Follow the procedure in [before working inside your computer](#).

i **NOTE:** Ensure that you remove the security cable from the security-cable slot (if applicable).

About this task

The following images indicate the location of the side cover and provide a visual representation of the removal procedure.



1x
#6-32

1



2



Steps

1. Loosen the thumbscrew (#6-32) that secures the side cover to the computer.
2. Slide the side cover towards the front of the computer and remove the side cover from the computer.

Installing the side cover

Prerequisites

If you are replacing a component, remove the existing component before performing the installation procedure.

About this task

The following image indicates the location of the side cover and provides a visual representation of the installation procedure.



1x
#6-32

1





Steps

1. Align the side cover with the grooves on the computer.
2. Slide the side cover into the chassis towards the front of the computer.
3. Tighten the thumbscrew (#6-32) to secure the side cover to the computer.

Next steps

1. Follow the procedure in [after working inside your computer](#).

2.5-inch hard drive

Removing the 2.5-inch hard-drive assembly

Prerequisites

1. Follow the procedure in [before working inside your computer](#).
2. Remove the [side cover](#).

About this task

The following image(s) indicate the location of the 2.5-inch hard-drive assembly and provides a visual representation of the removal procedure.

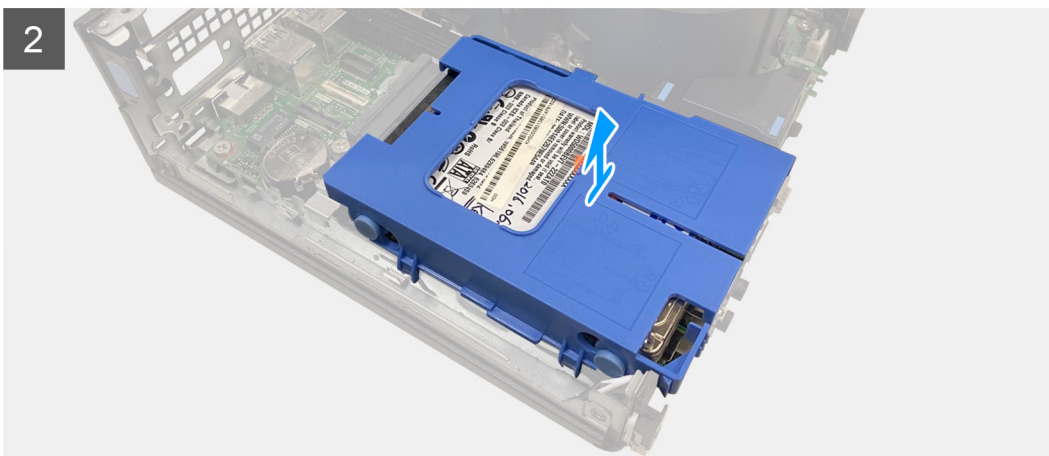
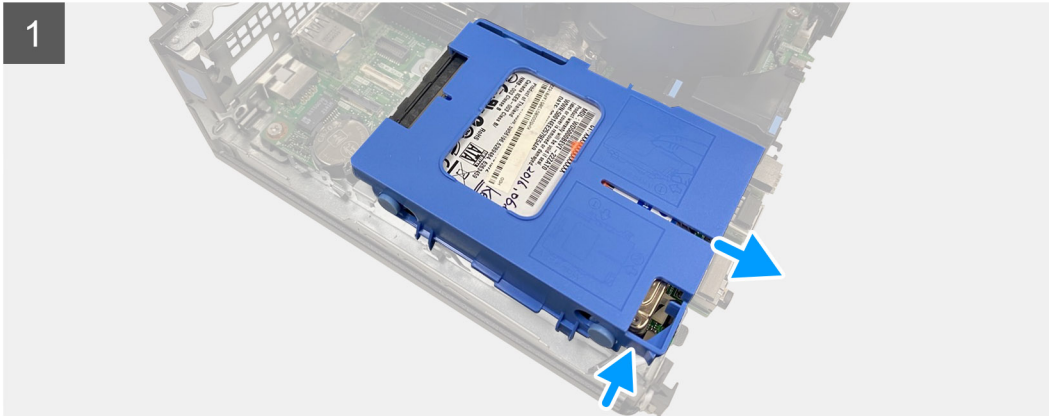
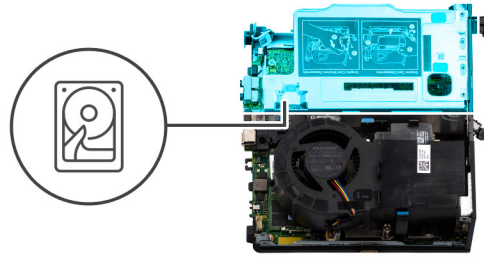

Steps

1. Place the computer on its side with the left side facing up.
2. Press the release tabs on the hard-drive caddy and slide the hard-drive caddy out to disconnect from the connector on the system board.
3. Lift the hard-drive assembly from the computer.

NOTE: Note the orientation of the hard drive so that you can replace it correctly.

Removing the 2.5-inch hard-drive caddy

Prerequisites

1. Follow the procedure in [before working inside your computer](#).
2. Remove the [side cover](#).

About this task

The following image(s) provides a visual representation of the 2.5-inch hard-drive caddy removal procedure.



Steps

1. Pry the hard-drive caddy to release the tabs on the caddy from the slots on the 2.5-inch hard drive.
2. Lift the 2.5-inch hard drive off the hard-drive caddy.

Installing the 2.5-inch hard-drive caddy

Prerequisites

If you are replacing a component, remove the existing component before performing the installation procedure.

About this task

The following image(s) provide a visual representation of the 2.5-inch hard-drive caddy installation procedure.

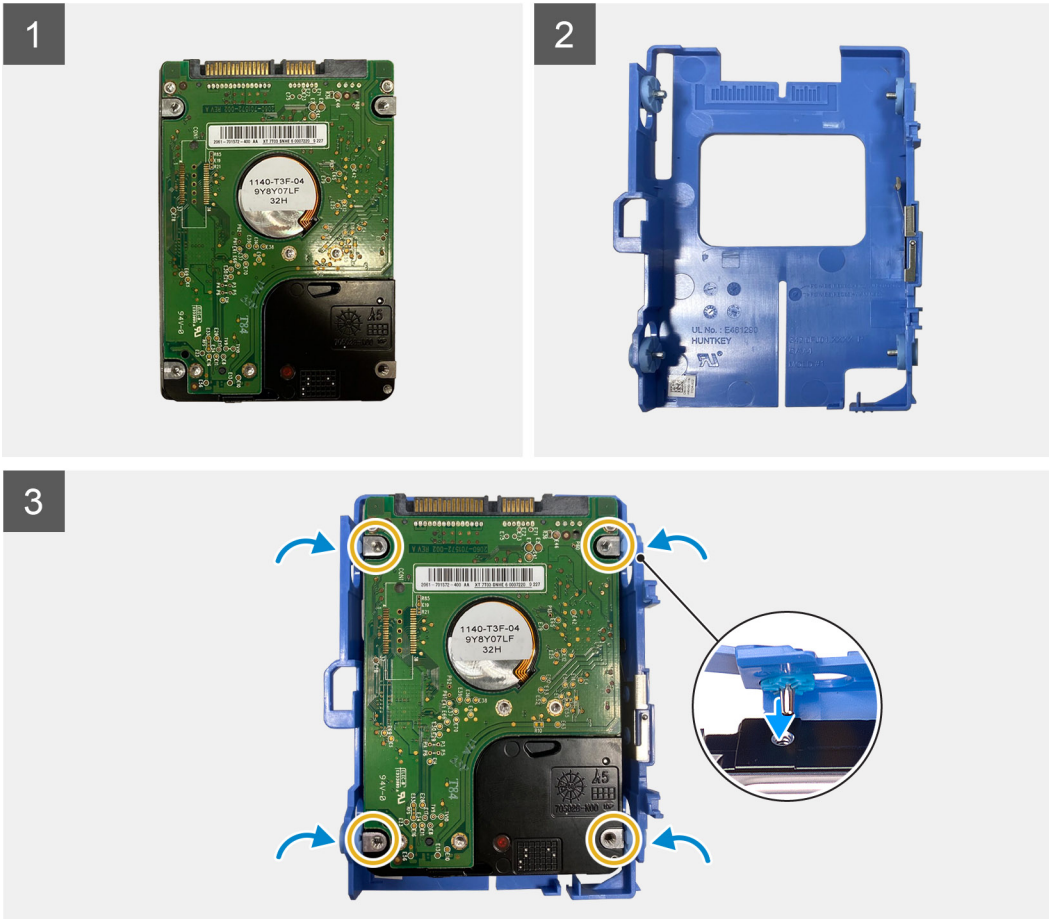

Steps

1. Place the 2.5-inch hard drive into the hard-drive caddy and align the tabs on the caddy with the slots on the hard drive.
2. Snap the hard-drive caddy onto the 2.5-inch hard drive.

Next steps

1. Install the [side cover](#).
2. Follow the procedure in [after working inside your computer](#).

Installing the 2.5-inch hard-drive assembly

Prerequisites

If you are replacing a component, remove the existing component before performing the installation procedure.

About this task

The following image(s) indicate the location of the 2.5-inch hard-drive assembly and provide a visual representation of the installation procedure.

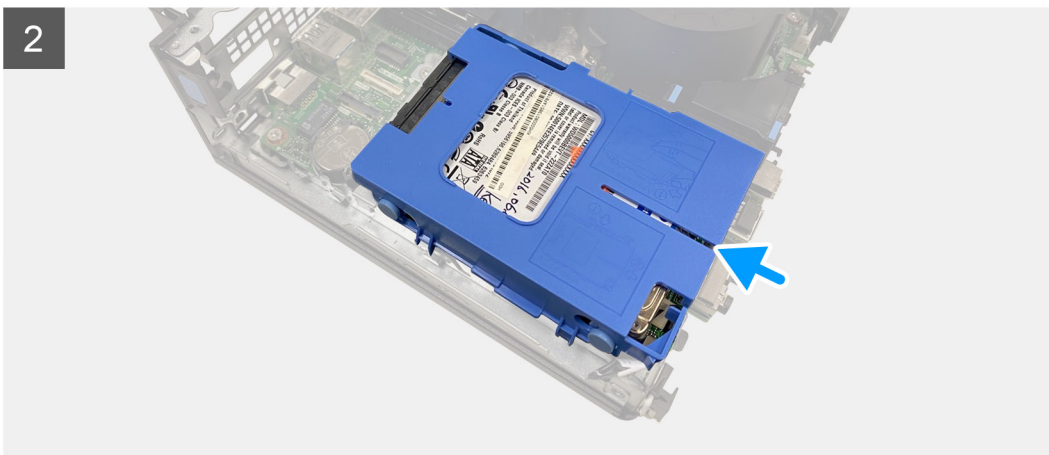
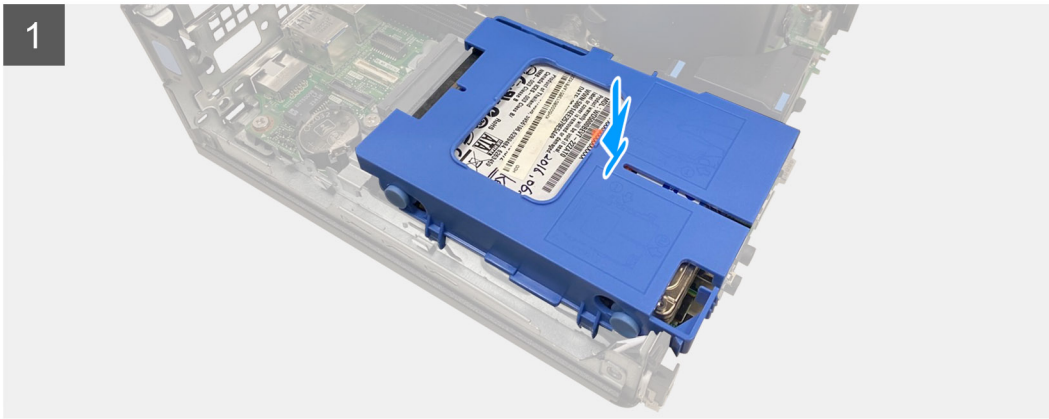
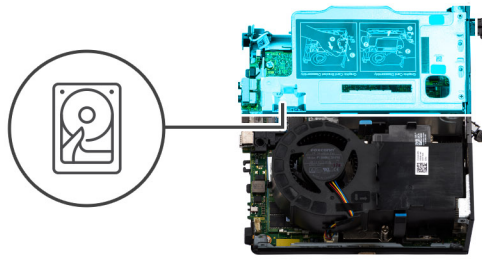

Steps

1. Align and place the hard-drive assembly into the slot on the computer.
2. Slide the hard-drive assembly towards the connector on the system board until it snaps into place.

Next steps

1. Install the [side cover](#).
2. Follow the procedure in [after working inside your computer](#).

Riser card

Removing the riser card

Prerequisites

1. Follow the procedure in [before working inside your computer](#).
2. Remove the [side cover](#).

About this task

The following image(s) indicate the location of the riser card and provide a visual representation of the removal procedure.



2x
M3x5

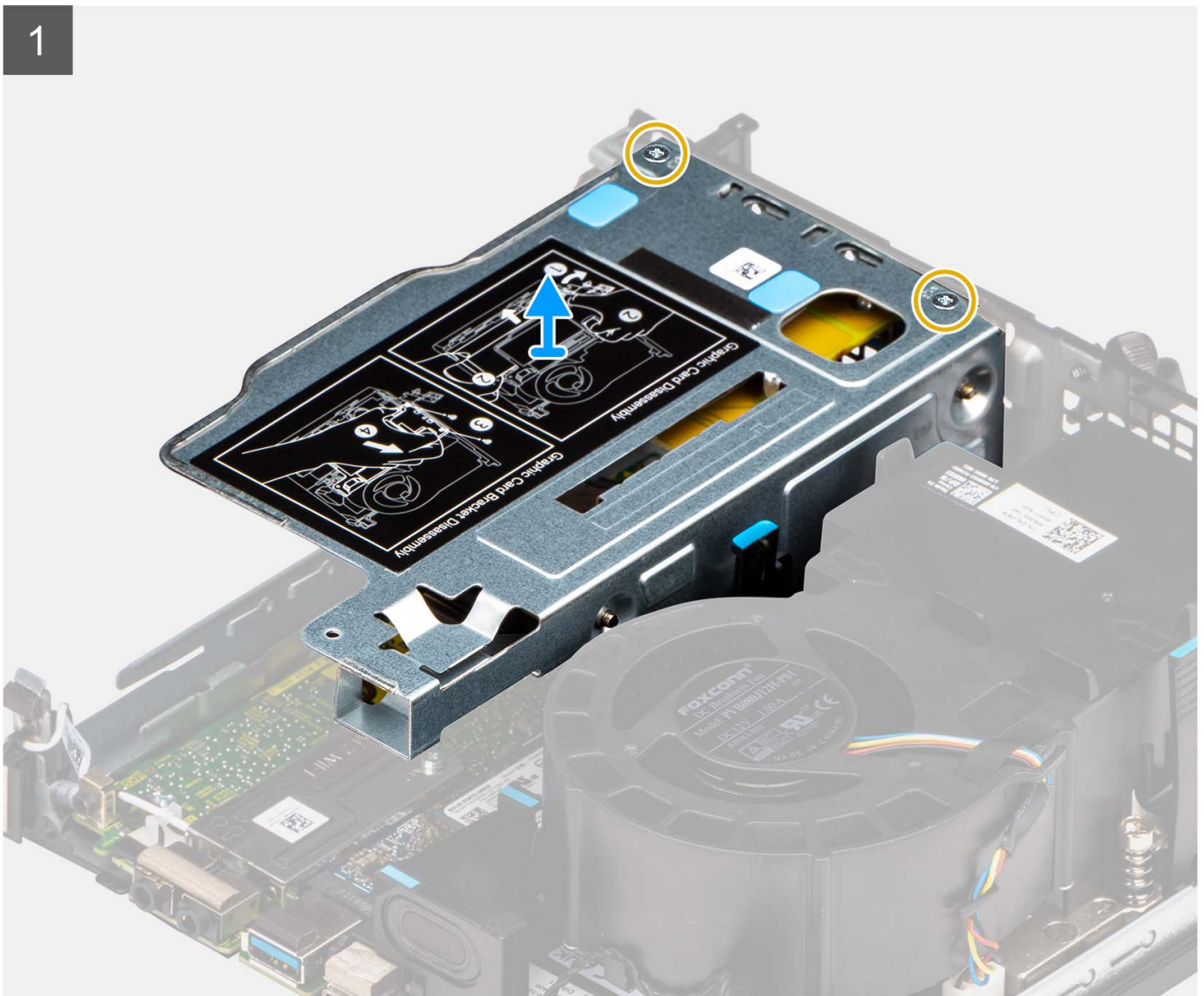

Steps

1. Place the computer on its side with the left side facing up.
2. Remove the two (M3x5) screws that secure the riser card to the chassis.
3. Lift the riser card away from the computer.

Installing the riser card

Prerequisites

If you are replacing a component, remove the existing component before performing the installation procedure.

About this task

The following image(s) indicate the location of the riser card and provide a visual representation of the installation procedure.



2x
M3x5

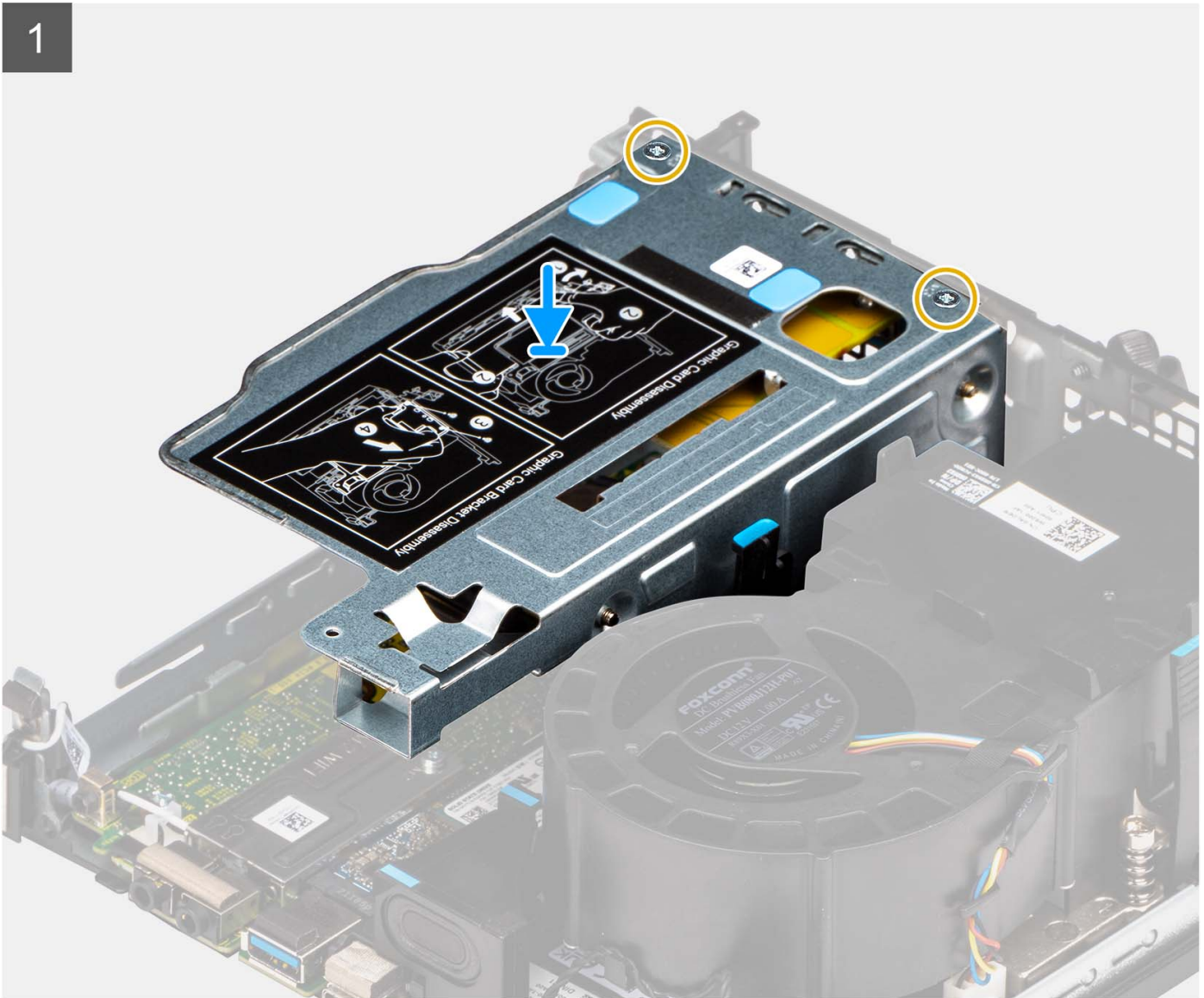

Steps

1. Align the screw holes on the riser card with the screw holes on the chassis.
2. Replace the two (M3x5) screws to secure the riser card to the chassis.

Next steps

1. Install the [side cover](#).
2. Follow the procedure in [after working inside your computer](#).

Wireless card

Removing the wireless card

Prerequisites

1. Follow the procedure in [before working inside your computer](#).
2. Remove the [side cover](#).
3. Remove the [hard-drive assembly](#).

About this task

The following image(s) indicate the location of the wireless card and provide a visual representation of the removal procedure.



2x
M2x3

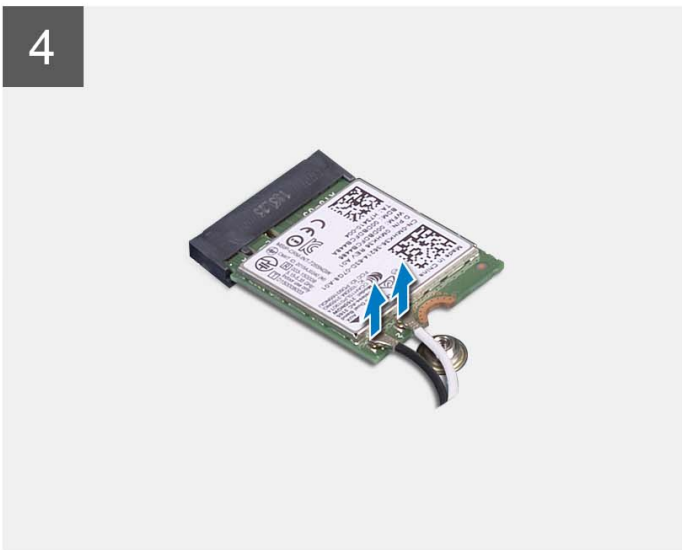
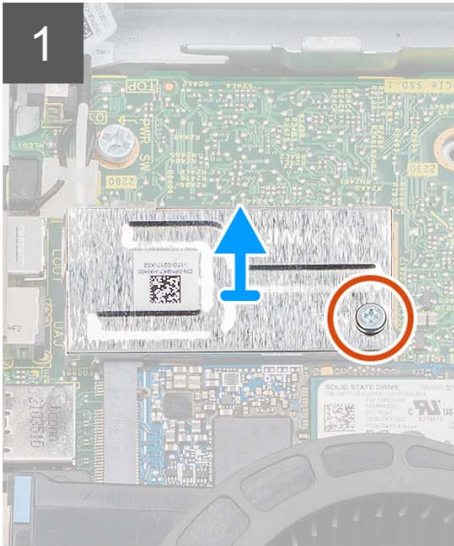
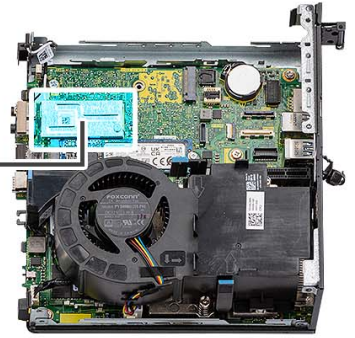

Steps

1. Place the computer on its side with the left side facing up.
2. Remove the screw (M2x3) that secure the wireless-card shield to the system board.
3. Lift the wireless-card shield out of the computer.
4. Remove the screw (M2x3) that secure the Wireless-card bracket to the wireless card.
5. Slide and remove the wireless-card bracket off the wireless card.
6. Disconnect the antenna cables from the wireless card.
7. Slide and remove the wireless card from the wireless-card slot.

Installing the wireless card

Prerequisites

If you are replacing a component, remove the existing component before performing the installation procedure.

About this task

The following image(s) indicates the location of the wireless card and provides a visual representation of the installation procedure.



2x
M2x3

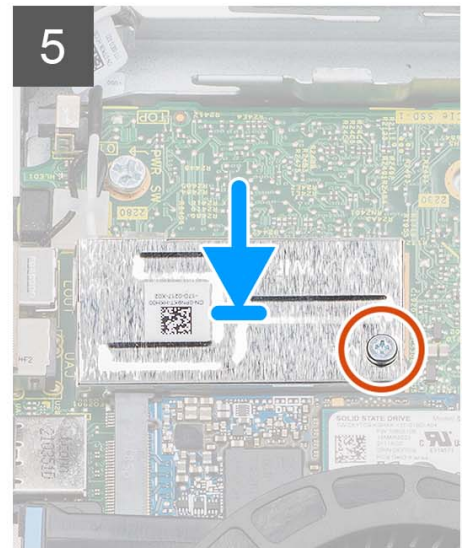
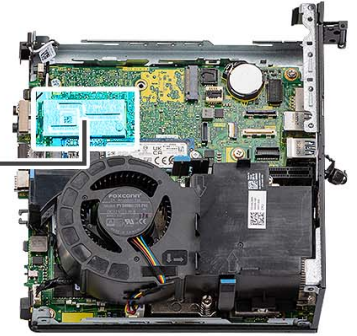

Steps

1. Connect the antenna cables to the wireless card.

The following table provides the antenna-cable color scheme for the WLAN card of your computer.

Table 2. Antenna-cable color scheme

Connectors on the wireless card	Antenna-cable color	Silkscreen marking	
Main	White	MAIN	△ (white triangle)
Auxiliary	Black	AUX	▲ (black triangle)

2. Place the wireless-card bracket on the wireless card.
3. Align the notch on the wireless card with the tab on the wireless-card slot.
4. Slide the wireless card at an angle into the wireless-card slot.
5. Replace the screw (M2x3) to secure the wireless card and wireless-card bracket to the system board.
6. Align and place the wireless-card shield on the system board and wireless card.
7. Replace the screw (M2x3) to secure the wireless-card shield to the system board.

Next steps

1. Install the [hard-drive assembly](#).
2. Install the [side cover](#).
3. Follow the procedure in [after working inside your computer](#).

Speaker

Removing the speaker

Prerequisites

1. Follow the procedure in [before working inside your computer](#).
2. Remove the [side cover](#).

About this task

The following image(s) indicate the location of the speaker and provide a visual representation of the removal procedure.

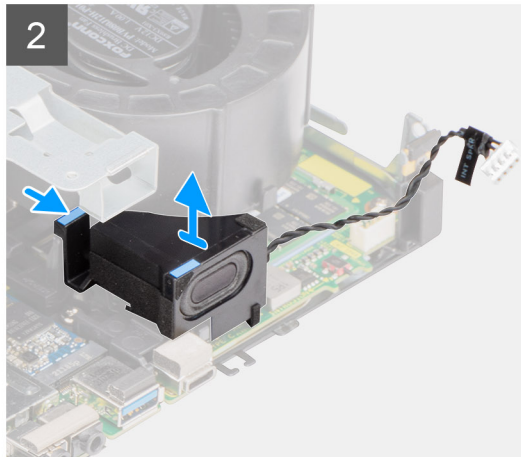
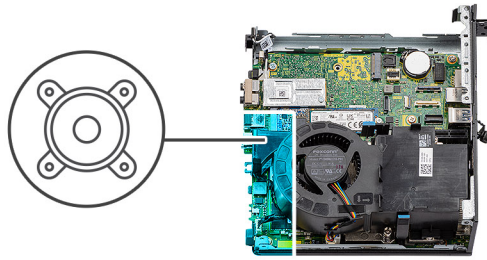

Steps

1. Disconnect the speaker cable from the connector on the system board.
2. Unroute the speaker cable from the routing guide on the fan assembly.
3. Press the release tab and lift the speaker along with the cable from the system board.

Installing the speaker

Prerequisites

If you are replacing a component, remove the existing component before performing the installation procedure.

About this task

The following image(s) indicate the location of the speaker and provide a visual representation of the installation procedure.

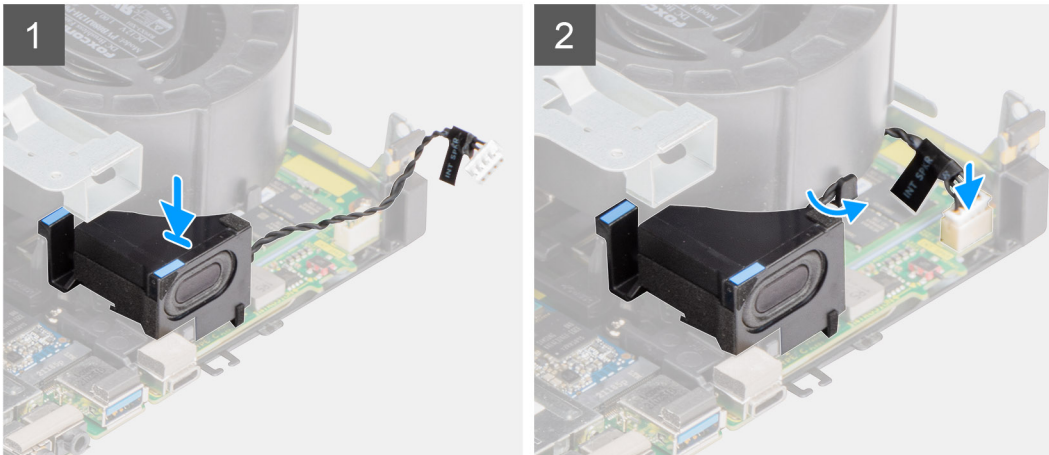
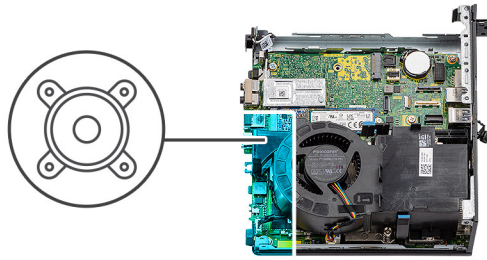

Steps

1. Align and insert the speaker into the slot and press it until the release tab clicks.
2. Route the speaker cable through the routing guide on the fan assembly.
3. Connect the speaker cable to the connector on the system board.

Next steps

1. Install the [side cover](#).
2. Follow the procedure in [after working inside your computer](#).

Processor fan

Removing the processor fan

Prerequisites

1. Follow the procedure in [before working inside your computer](#).
2. Remove the [side cover](#).
3. Remove the [speaker](#).

About this task

The following image(s) indicate the location of the processor fan and provide a visual representation of the removal procedure.

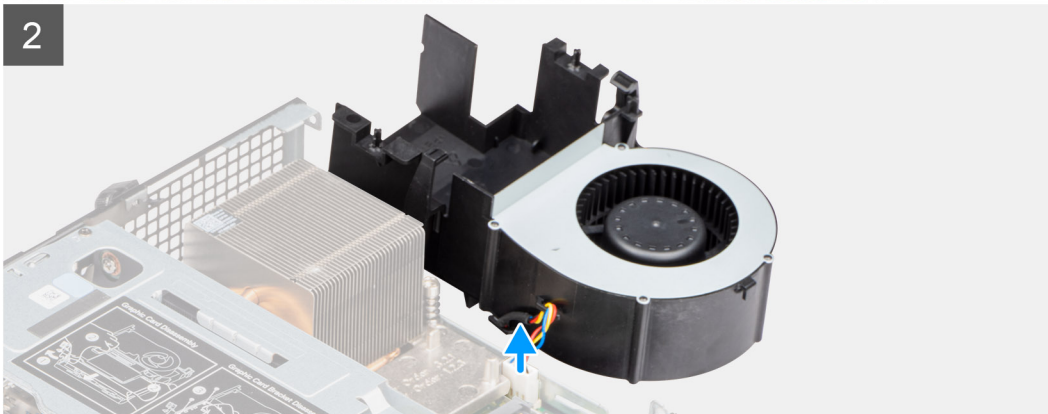
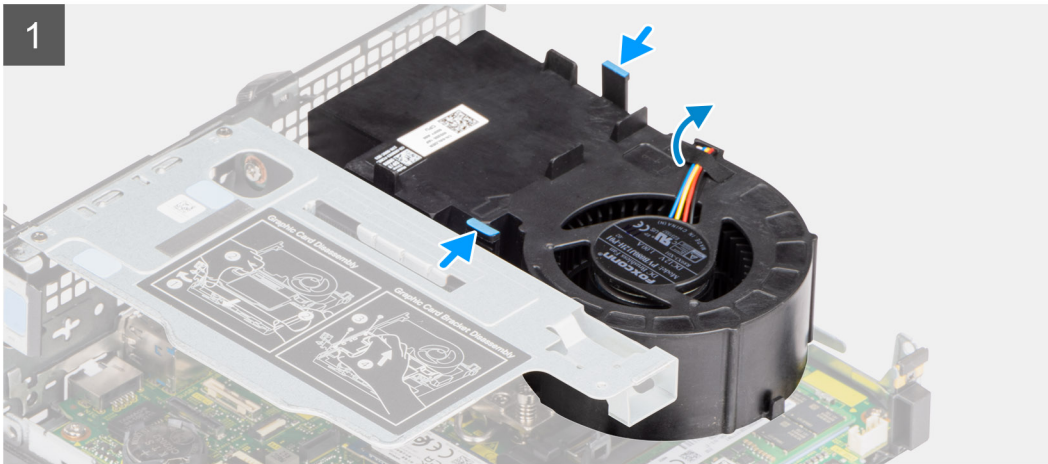
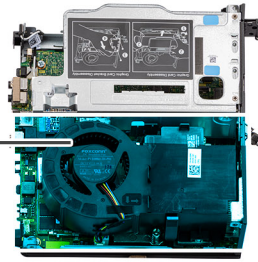
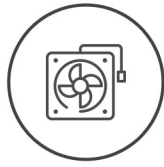

Steps

1.  **NOTE:** Unroute the speaker cable from the routing guide on the processor fan.

Press the blue tabs on both sides of the processor fan, and lift the fan to release it from the computer and turn it over.

2. Disconnect the fan cable from the connector on the system board.
3. Lift the processor fan out of the computer.

Installing the processor fan

Prerequisites

If you are replacing a component, remove the existing component before performing the installation procedure.

About this task

The following image(s) indicate the location of the processor fan and provide a visual representation of the installation procedure.

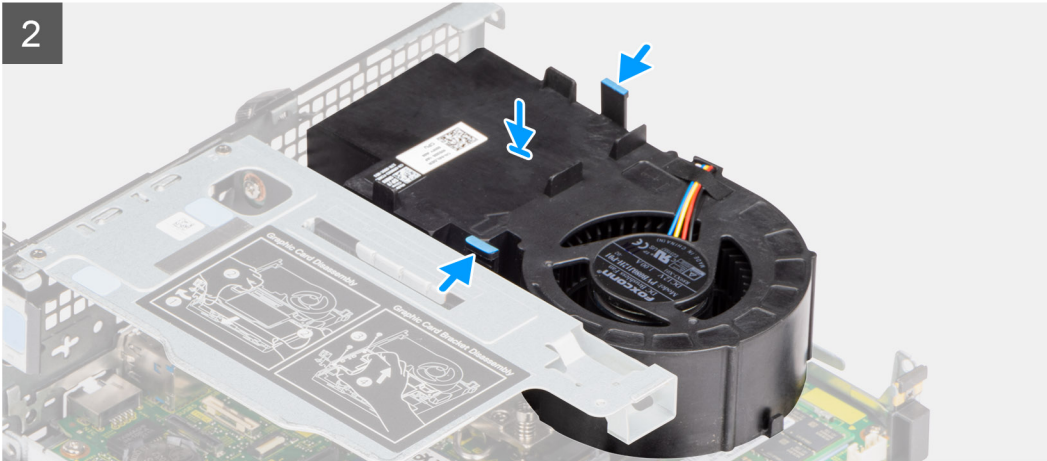
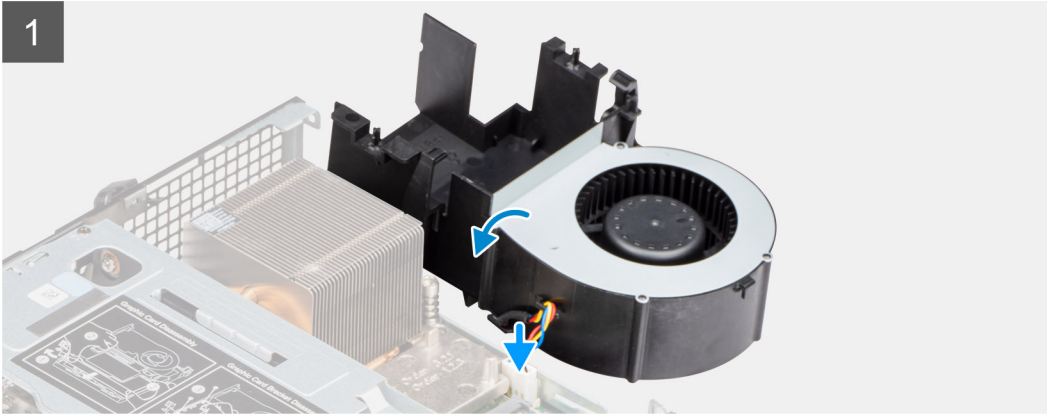
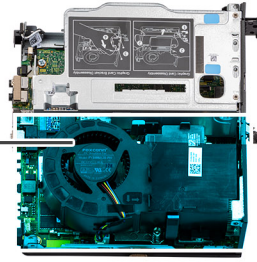
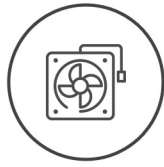

Steps

1. Connect the fan cable to the connector on the system board, and turn up-side down.
2. Press the release tab on the processor fan and place it on the computer until it clicks into place.

i **NOTE:** Route the speaker cable through the routing guides on the fan assembly.

Next steps

1. Install the [speaker](#).
2. Install the [side cover](#).
3. Follow the procedure in [after working inside your computer](#).

Memory module

Removing the memory modules

Prerequisites

1. Follow the procedure in [before working inside your computer](#).
2. Remove the [side cover](#).
3. Remove the [processor fan](#).

About this task

The following image(s) indicate the location of the memory modules and provide a visual representation of the removal procedure.

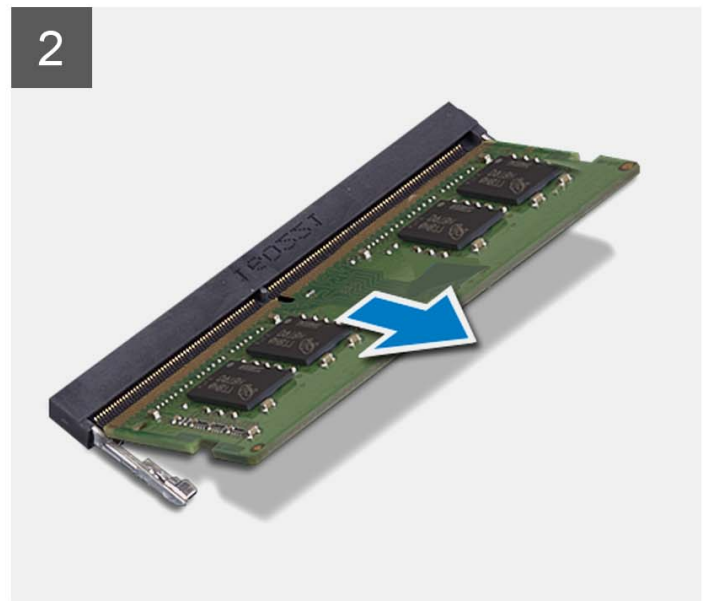
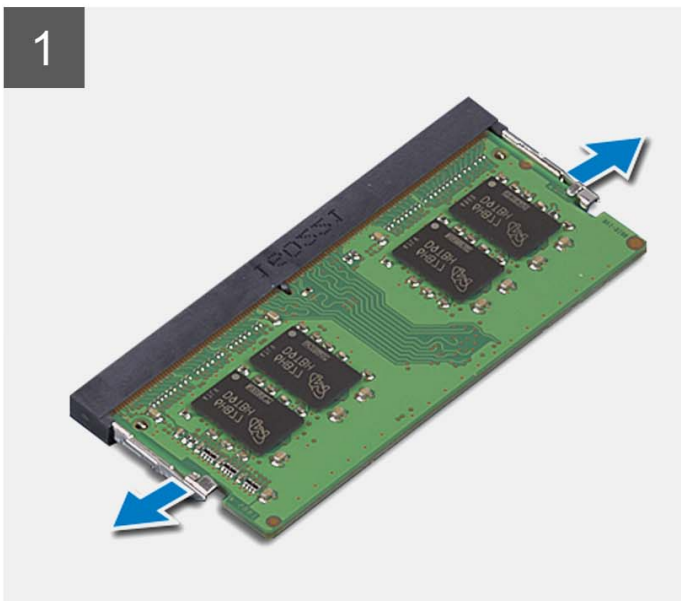
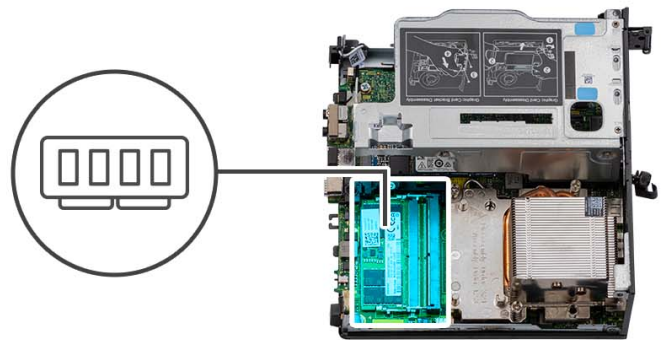

Steps

1. Place the computer on its side with the left side facing up.
2. Carefully spread apart the securing-clips on each end of the memory-module slot.
3. Grasp the memory module near the securing clip, and then gently ease the memory module out of the memory-module slot.

CAUTION: To prevent damage to the memory module, hold the memory module by the edges. Do not touch the components on the memory module.

NOTE: Repeat step 2 to step 3 to remove any other memory modules installed in your computer.

NOTE: Note the slot and the orientation of the memory module in order to replace it in the correct slot.

NOTE: If the memory module is difficult to remove, gently ease the memory module back and forth to remove it from the slot.

Installing the memory modules

Prerequisites

If you are replacing a component, remove the existing component before performing the installation procedure.

About this task

The following image(s) indicate the location of the memory modules and provide a visual representation of the installation procedure.

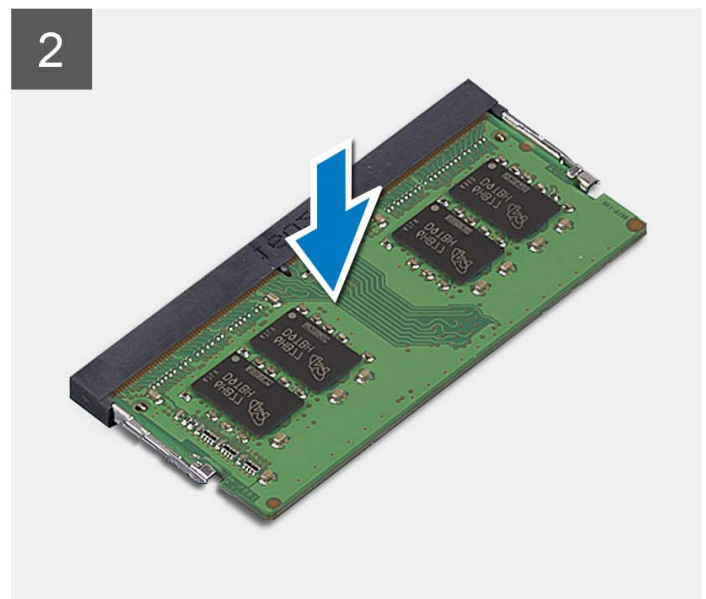
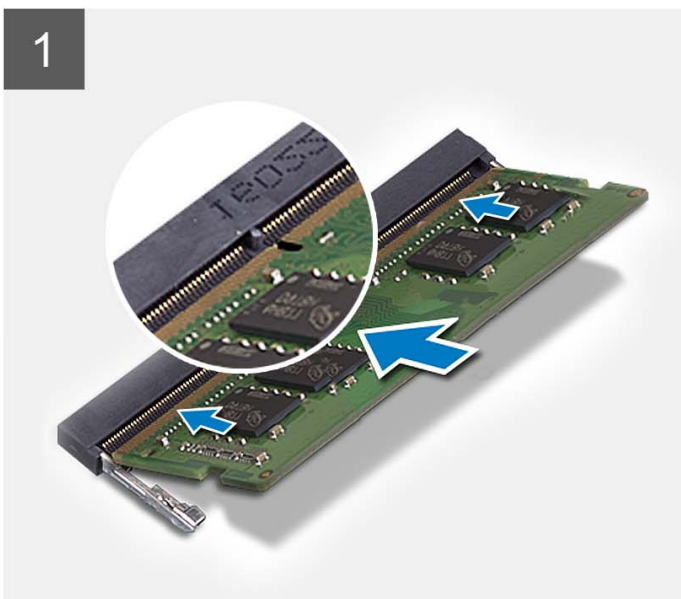
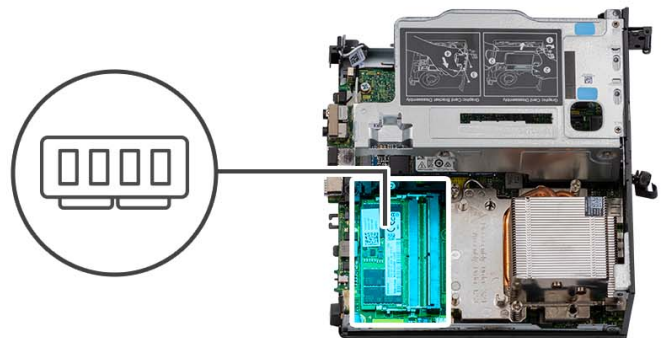

Steps

1. **NOTE:** The thermal pad is applicable only for computers with 32 GB x 2 configuration, install the thermal pad before installing the 32 GB x 2 memory module.

Align the notch on the memory module with the tab on the memory-module slot.

2. Insert the memory module into the memory-module slot.
3. Press down on the memory module until the memory module snaps into position and the securing clip locks in place.

CAUTION: To prevent damage to the memory module, hold the memory module by the edges. Do not touch the components on the memory module.

1. **NOTE:** The securing clips return to the locked position. If you do not hear the click, remove the memory module and reinstall it.

NOTE: If the memory module is difficult to remove, gently ease the memory module back and forth to remove it from the slot.

Next steps

1. Install the [processor fan](#).
2. Install the [side cover](#).
3. Follow the procedure in [after working inside your computer](#).

M.2 solid-state drive

Removing the M.2 2230 PCIe solid-state drive (slot-1)

Prerequisites

1. Follow the procedure in [before working inside your computer](#).
2. Remove the [side cover](#).
3. Remove the [processor fan](#).
4. Remove the [riser card—optional](#).
5. Remove the [hard-drive assembly](#).

About this task

The following image(s) indicate the location of the solid-state drive and provide a visual representation of the removal procedure.



1x
M2x3.5

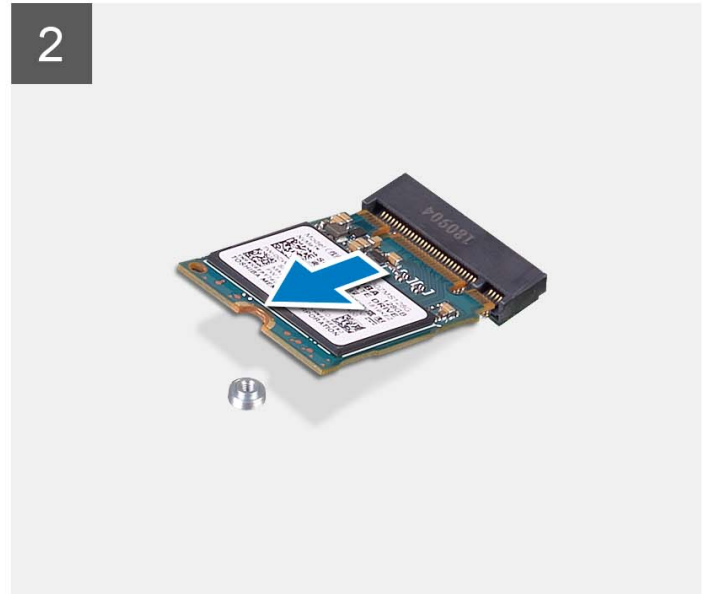
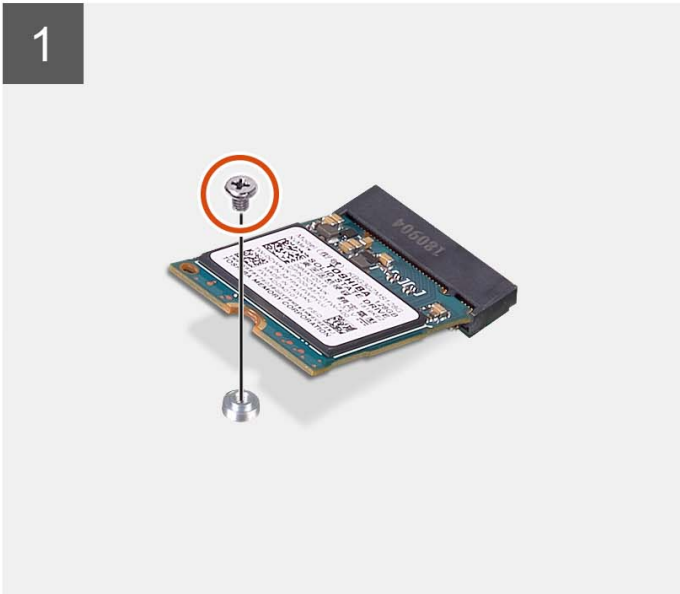
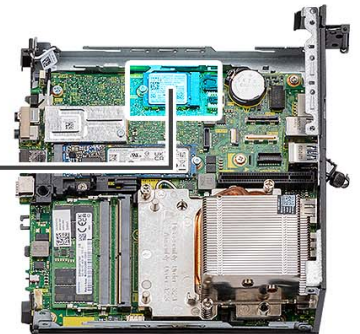

Steps

1. Place the computer on its side with the left side facing up.
2. Remove the screw (M2x3.5) that secures the 2230 solid-state drive to the system board.
3. Slide and lift the 2230 solid-state drive from the M.2 card slot on the system board.

Installing the M.2 2230 PCIe solid-state drive (slot-1)

Prerequisites

If you are replacing a component, remove the existing component before performing the installation procedure.

About this task

The following image(s) indicate the location of the solid-state drive and provides a visual representation of the installation procedure.



1x
M2x3.5

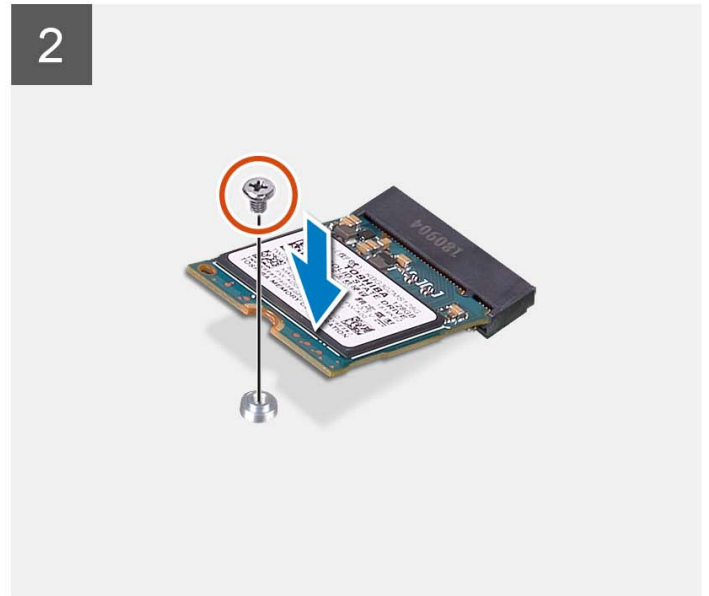
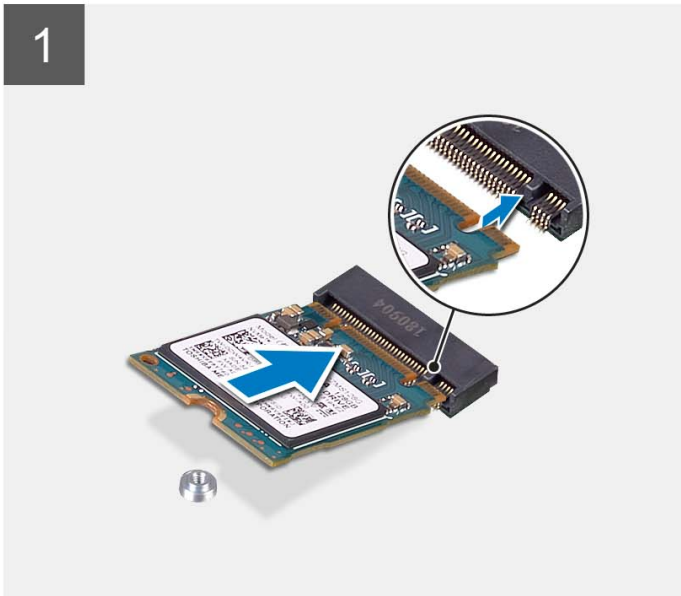
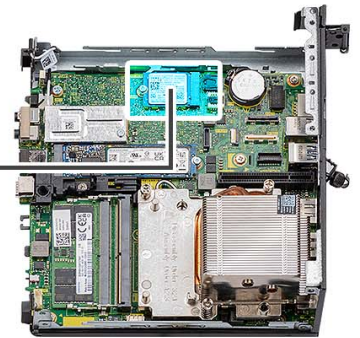

Steps

1. Align the notch on the 2230 solid-state drive with the tab on the M.2 card slot on the system board.
2. Slide the 2230 solid-state drive into the M.2 card slot on the system board.
3. Replace the screw (M2x3.5) that secures the 2230 solid-state drive to the system board.
4. Place the computer in an upright position.

Next steps

1. Install the [hard-drive assembly](#).
2. Install the [riser card](#)—optional.

3. Install the [processor fan](#).
4. Install the [side cover](#).
5. Follow the procedure in [after working inside your computer](#).

Removing the M.2 2280 PCIe solid-state drive (slot-1)

Prerequisites

1. Follow the procedure in [before working inside your computer](#).
2. Remove the [side cover](#).
3. Remove the [processor fan](#).
4. Remove the [riser card](#)—optional.
5. Remove the [hard-drive assembly](#).

About this task

The following image(s) indicate the location of the solid-state drive and provide a visual representation of the removal procedure.



1x
M2x3.5

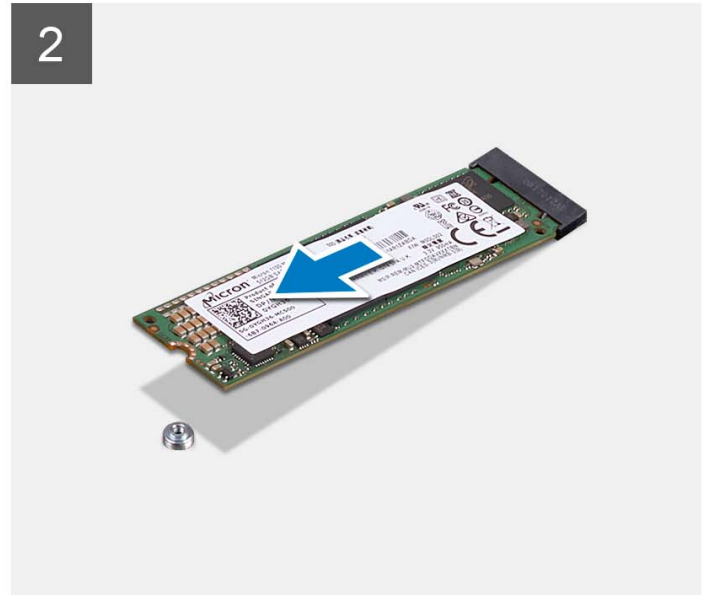
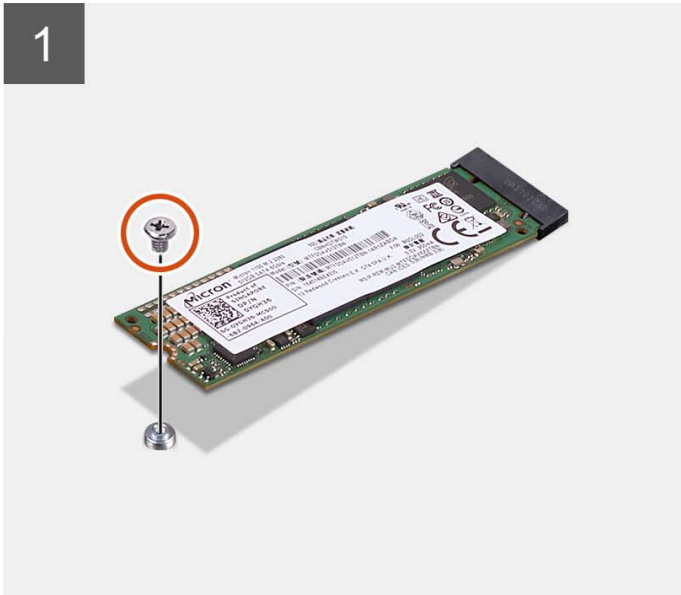
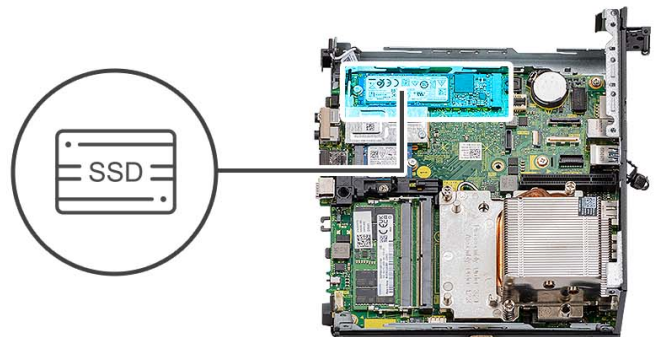

Steps

1. Place the computer on its side with the left side facing up.
2. Remove the screw (M2x3.5) that secures the 2280 solid-state drive to the system board.
3. Slide and lift the 2280 solid-state drive from the M.2 card slot on the system board.

Installing the M.2 2280 PCIe solid-state drive (slot-1)

Prerequisites

If you are replacing a component, remove the existing component before performing the installation procedure.

About this task

The following image(s) indicate the location of the solid-state drive and provides a visual representation of the installation procedure.



1x
M2x3.5

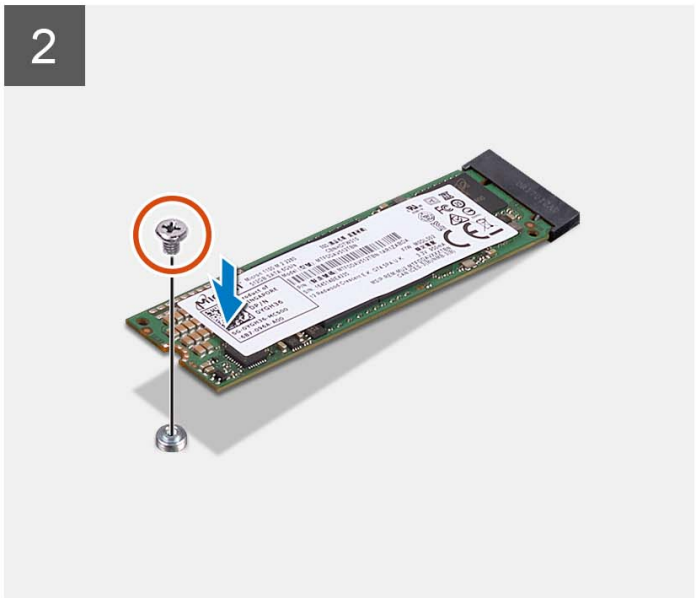
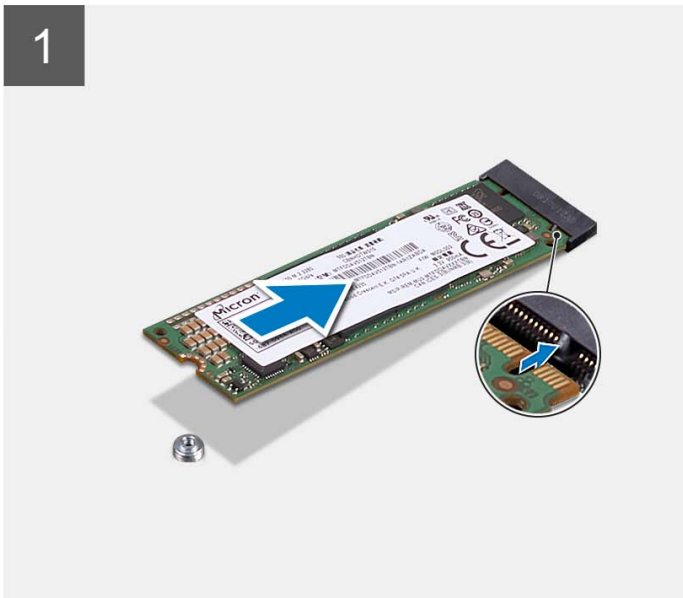
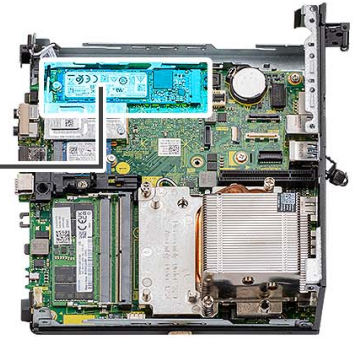

Steps

1. Align the notch on the 2280 solid-state drive with the tab on the M.2 card slot on the system board.
2. Slide the 2280 solid-state drive into the M.2 card slot on the system board.
3. Replace the screw (M2x3.5) that secures the 2280 solid-state drive to the system board.
4. Place the computer in an upright position.

Next steps

1. Install the [hard-drive assembly](#).
2. Install the [riser card—optional](#).
3. Install the [processor fan](#).
4. Install the [side cover](#).
5. Follow the procedure in [after working inside your computer](#).

Removing the M.2 2230 PCIe solid-state drive (slot-0)

Prerequisites

1. Follow the procedure in [before working inside your computer](#).
2. Remove the [side cover](#).
3. Remove the [processor fan](#).
4. Remove the [riser card](#)—optional.
5. Remove the [hard-drive assembly](#).

About this task

The following image(s) indicate the location of the solid-state drive and provide a visual representation of the removal procedure.



1x
M2x3.5

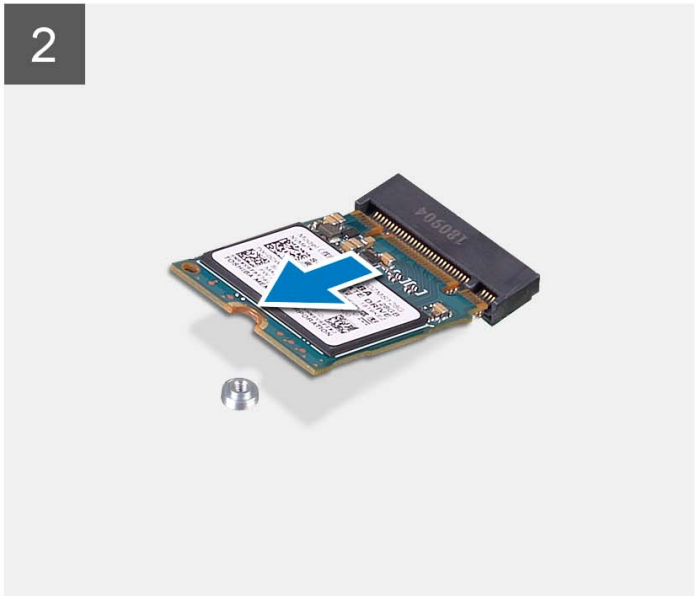
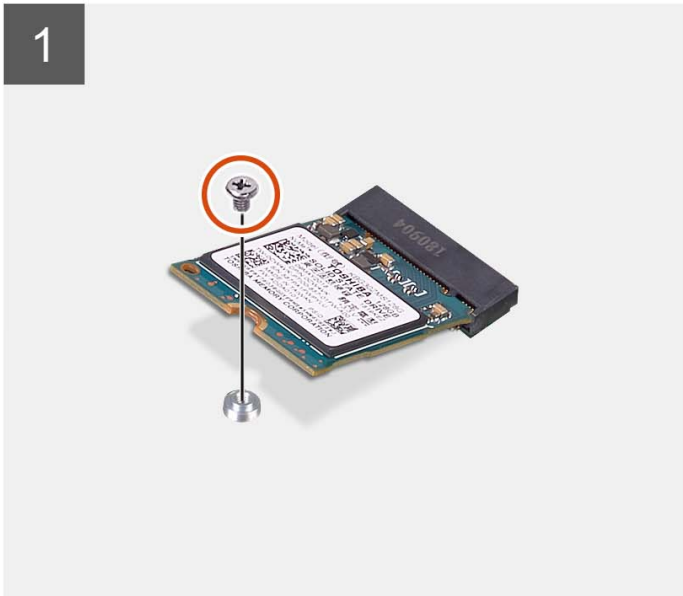
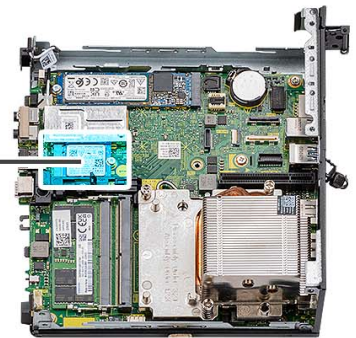

Steps

1. Place the computer on its side with the left side facing up.
2. Remove the screw (M2x3.5) that secures the 2230 solid-state drive to the system board.
3. Slide and lift the 2230 solid-state drive from the M.2 card slot on the system board.

Installing the M.2 2230 PCIe solid-state drive (slot-0)

Prerequisites

If you are replacing a component, remove the existing component before performing the installation procedure.

About this task

The following image(s) indicate the location of the solid-state drive and provides a visual representation of the installation procedure.



1x
M2x3.5

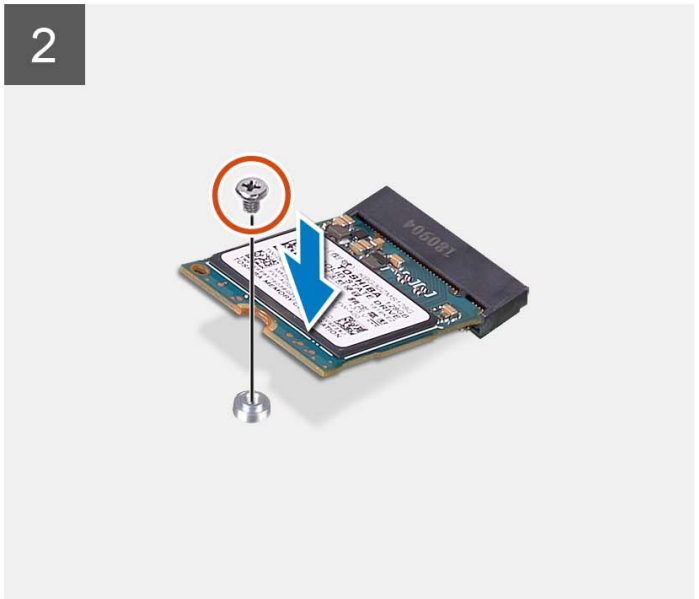
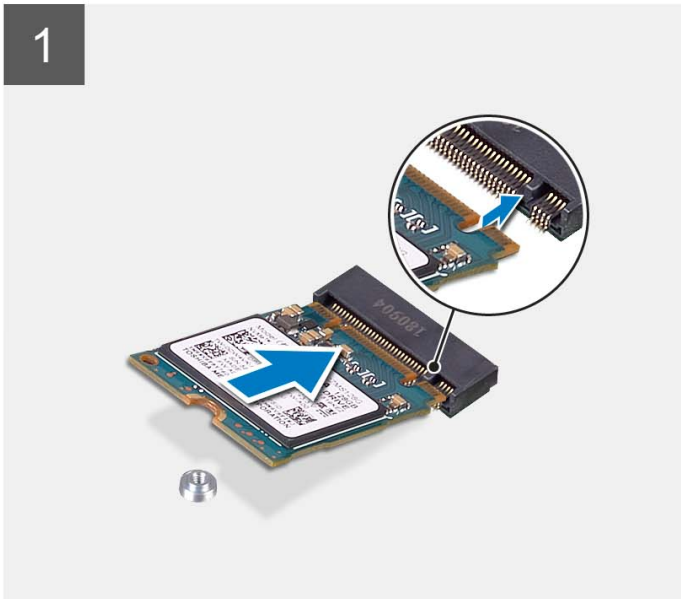
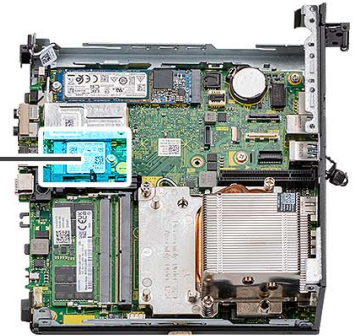
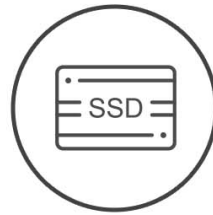

Steps

1. Align the notch on the 2230 solid-state drive with the tab on the M.2 card slot on the system board.
2. Slide the 2230 solid-state drive into the M.2 card slot on the system board.
3. Replace the screw (M2x3.5) that secures the 2230 solid-state drive to the system board.
4. Place the computer in an upright position.

Next steps

1. Install the [hard-drive assembly](#).
2. Install the [riser card](#)—optional.
3. Install the [processor fan](#).
4. Install the [side cover](#).
5. Follow the procedure in [after working inside your computer](#).

Removing the M.2 2280 PCIe solid-state drive (slot-0)

Prerequisites

1. Follow the procedure in [before working inside your computer](#).
2. Remove the [side cover](#).
3. Remove the [processor fan](#).
4. Remove the [riser card](#)—optional.

5. Remove the [hard-drive assembly](#).

About this task

The following image(s) indicate the location of the solid-state drive and provide a visual representation of the removal procedure.



1x
M2x3.5

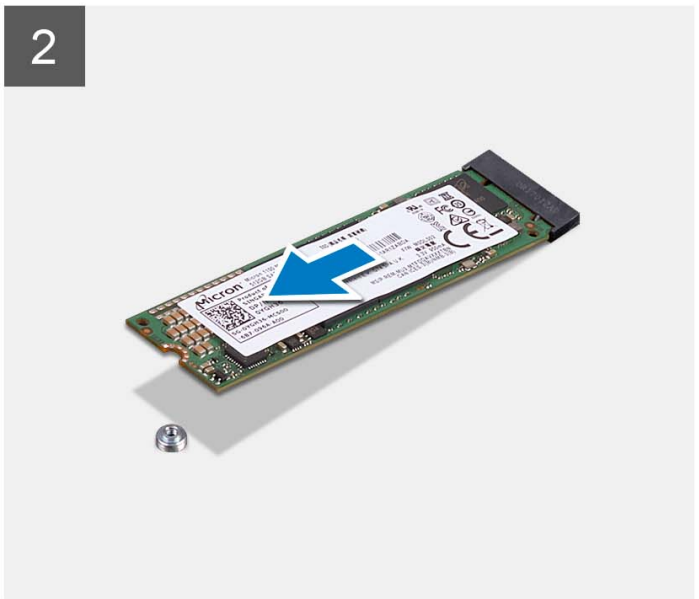
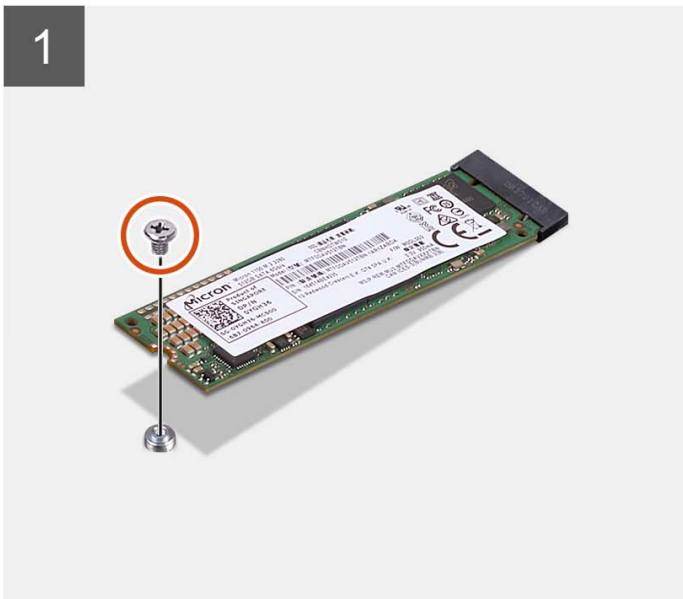
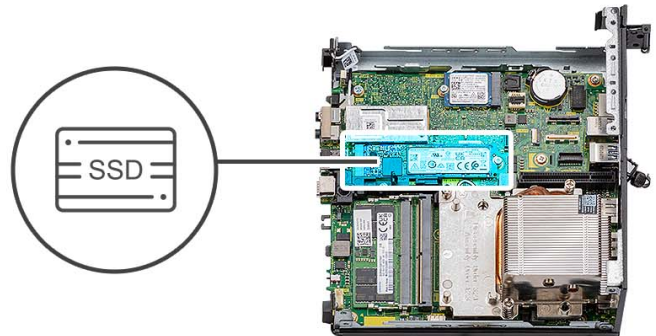

Steps

1. Place the computer on its side with the left side facing up.
2. Remove the screw (M2x3.5) that secures the 2280 solid-state drive to the system board.
3. Slide and lift the 2280 solid-state drive from the M.2 card slot on the system board.

Installing the M.2 2280 PCIe solid-state drive (slot-0)

Prerequisites

If you are replacing a component, remove the existing component before performing the installation procedure.

About this task

The following image(s) indicate the location of the solid-state drive and provides a visual representation of the installation procedure.



1x
M2x3.5

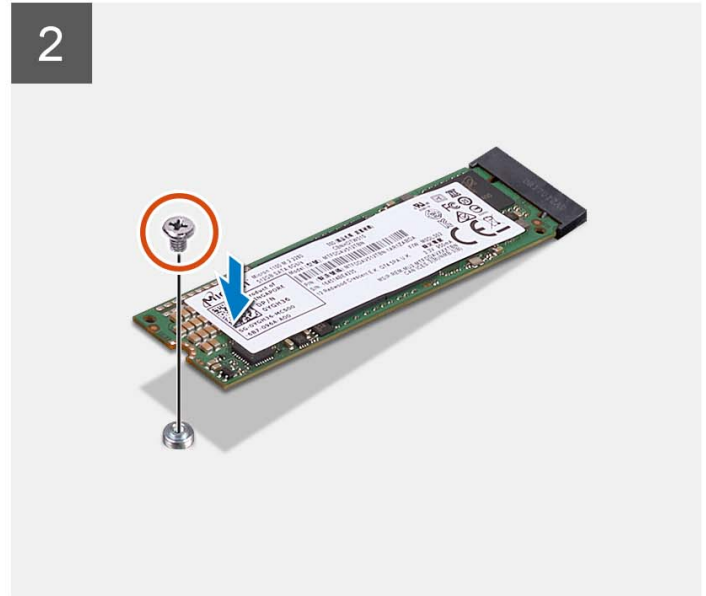
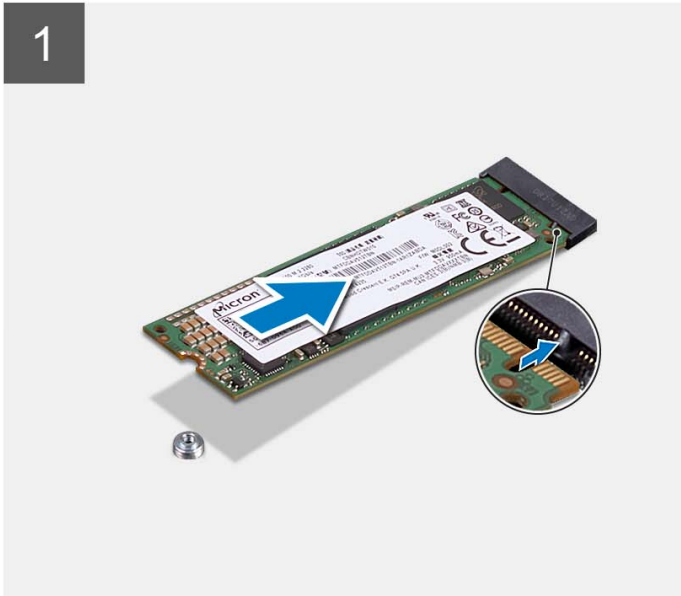
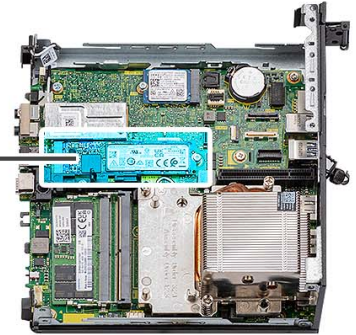

Steps

1. Align the notch on the 2280 solid-state drive with the tab on the M.2 card slot on the system board.
2. Slide the 2280 solid-state drive into the M.2 card slot on the system board.
3. Replace the screw (M2x3.5) that secures the 2280 solid-state drive to the system board.
4. Place the computer in an upright position.

Next steps

1. Install the [hard-drive assembly](#).
2. Install the [riser card](#)—optional.
3. Install the [processor fan](#).
4. Install the [side cover](#).
5. Follow the procedure in [after working inside your computer](#).

Expansion card

Removing the serial port PCIe card

Prerequisites

1. Follow the procedure in [before working inside your computer](#).
2. Remove the [side cover](#).

About this task

The following image(s) indicate the location of the serial port PCIe card and provide a visual representation of the removal procedure.

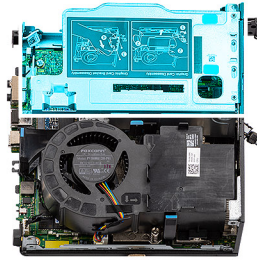

Steps

1. Place the computer on its side with the left side facing up.
2. Open the PCI retainer latch.
3. Slide and remove the serial port PCIe card out of the computer.
4. Insert the PCIe bracket and close the PCI retainer latch.

Installing the serial port PCIe card

Prerequisites

If you are replacing a component, remove the existing component before performing the installation procedure.

About this task

The following image indicates the location of the serial port PCIe card and provides a visual representation of the installation procedure.

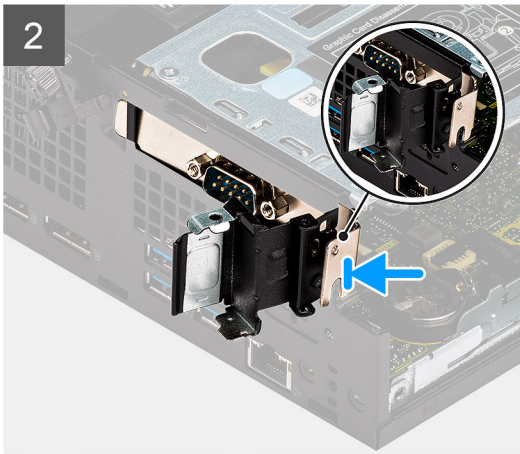
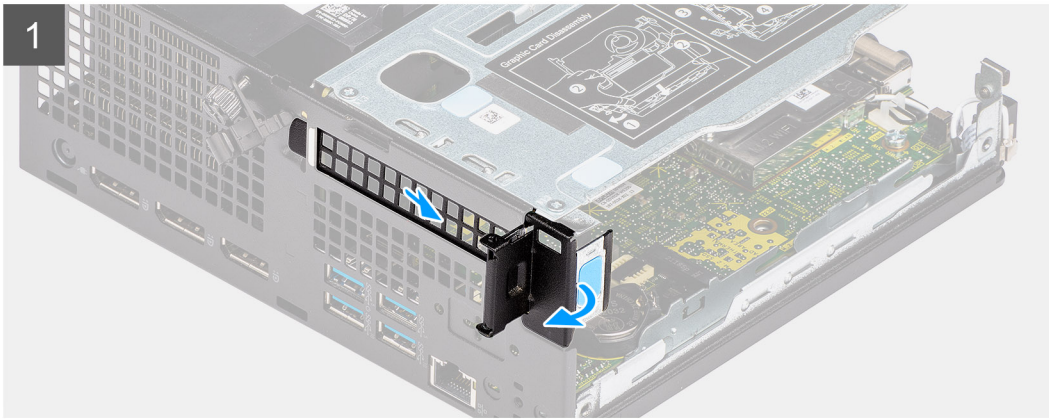
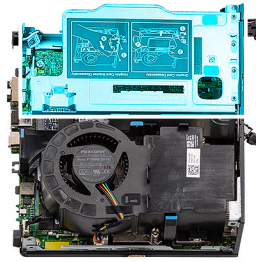

Steps

1. Open the PCI retainer latch and slide the PCIe bracket out of the computer.
2. Align the serial port PCIe card and slide it into the slot on the computer.
3. Ensure to check the serial port PCIe card assembly is placed within the structure limit.
4. Close the PCI retainer latch.

Next steps

1. Install the [side cover](#).
2. Follow the procedure in [after working inside your computer](#).

Removing the graphics card

Prerequisites

1. Follow the procedure in [before working inside your computer](#).
2. Remove the [side cover](#).

About this task

The following image(s) indicate the location of the graphics card and provide a visual representation of the removal procedure.

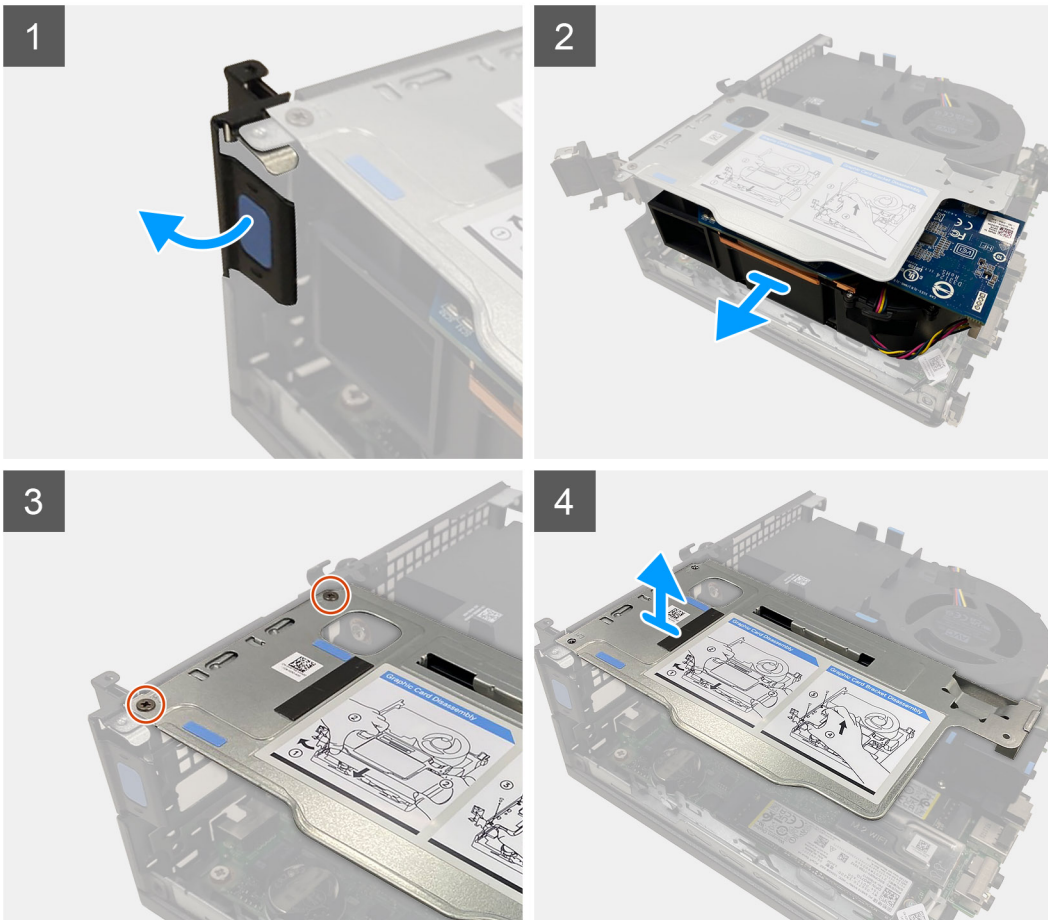
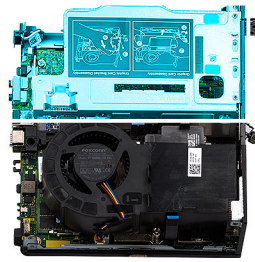

Steps

1. Pull and open the PCI retainer latch.
2. Slide the graphics card along the edges of the riser card to release it from the riser card.
3. Remove the two (M3x5) screws that secure the riser card to the chassis.
4. Lift the riser card away from the computer.

Installing the graphics card

Prerequisites

If you are replacing a component, remove the existing component before performing the installation procedure.

About this task

The following image(s) indicate the location of the graphics card and provide a visual representation of the installation procedure.

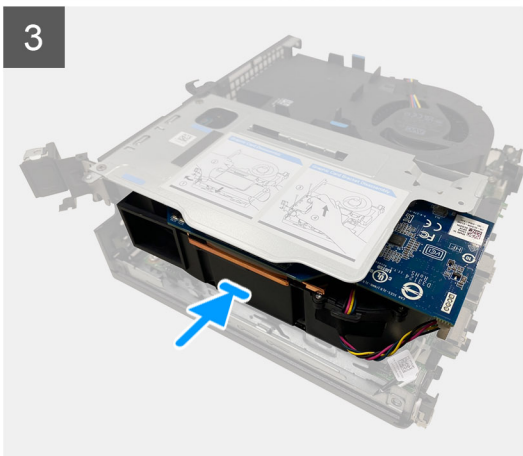
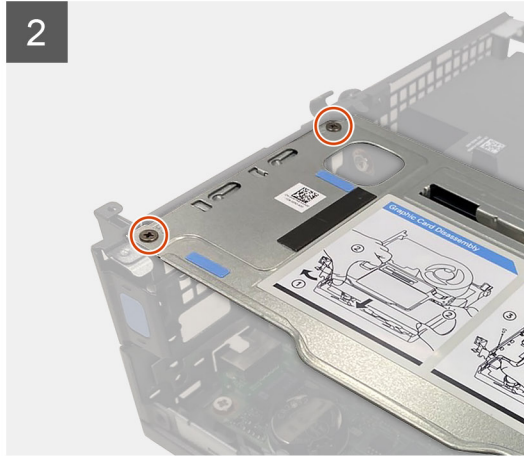
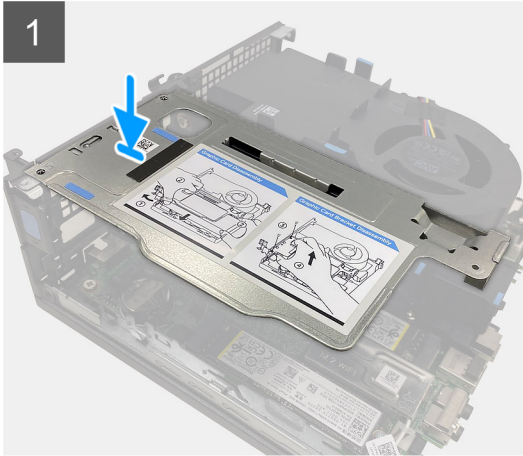
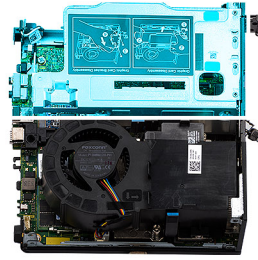

Steps

1. Align the screw holes on the riser card with the screw holes on the chassis.
2. Replace the two (M3x5) screws to secure the riser card to the chassis.
3. Slide the graphics card into the slot on the riser card until it clicks into place.
4. Close the PCI retainer latch and press until it clicks into place.

Next steps

1. Install the [side cover](#).
2. Follow the procedure in [after working inside your computer](#).

Optional I/O module

Removing the optional I/O module

Prerequisites

1. Follow the procedure in [before working inside your computer](#).
2. Remove the [side cover](#).
3. Remove the [hard-drive assembly](#).
4. Remove the [riser card](#).

About this task

The following image(s) indicate the location of the optional I/O module and provide a visual representation of the removal procedure.



2x
M3x3

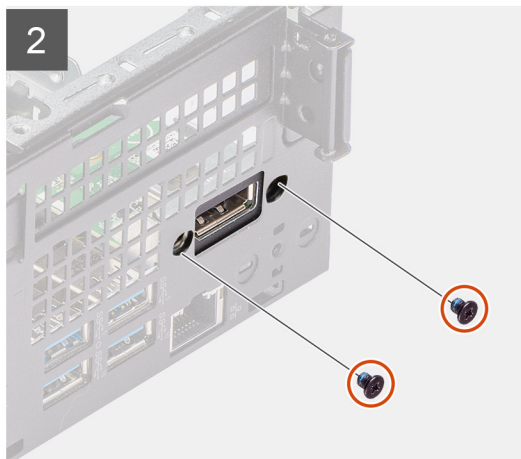
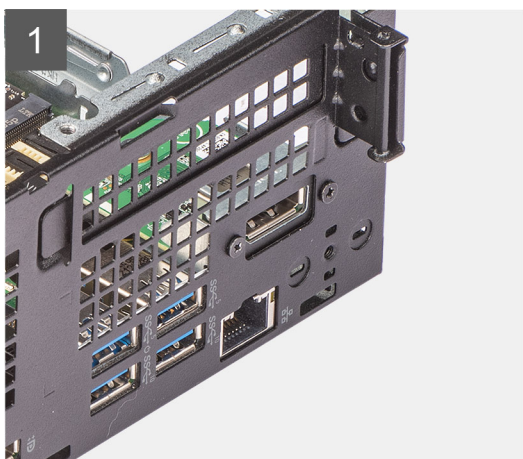
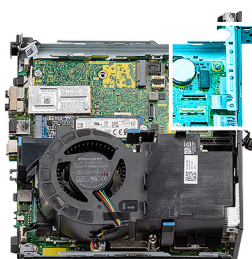

Steps

1. Place the computer on its side with the left side facing up.

2. Remove the two screws (M3x3) that secure the optional I/O module to the chassis.

NOTE: The screw type differs with the kind of I/O module used.

3. Slide and remove the optional I/O module from its slot in the chassis.

4. Disconnect the cable that connects the optional I/O module to the system board.

5. Remove the I/O module from the computer.

Installing the optional I/O module

Prerequisites

If you are replacing a component, remove the existing component before performing the installation procedure.

About this task

The following image indicates the location of the optional I/O module and provides a visual representation of the installation procedure.



2x
M3x3

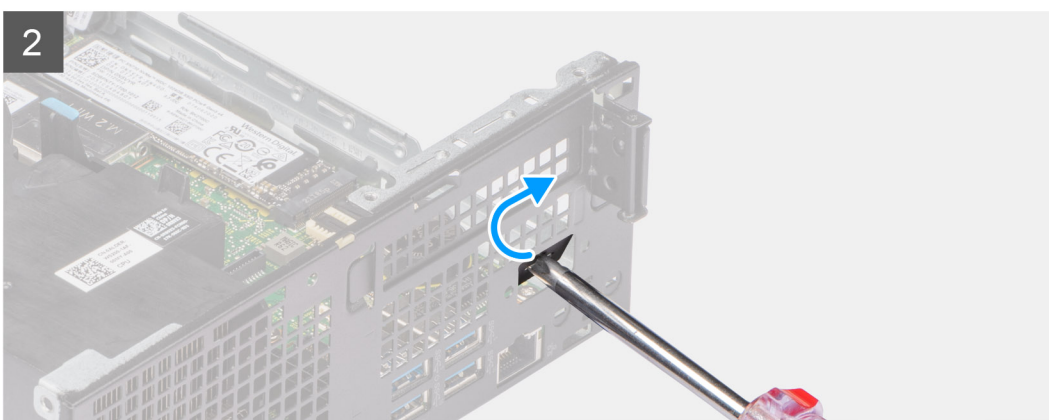
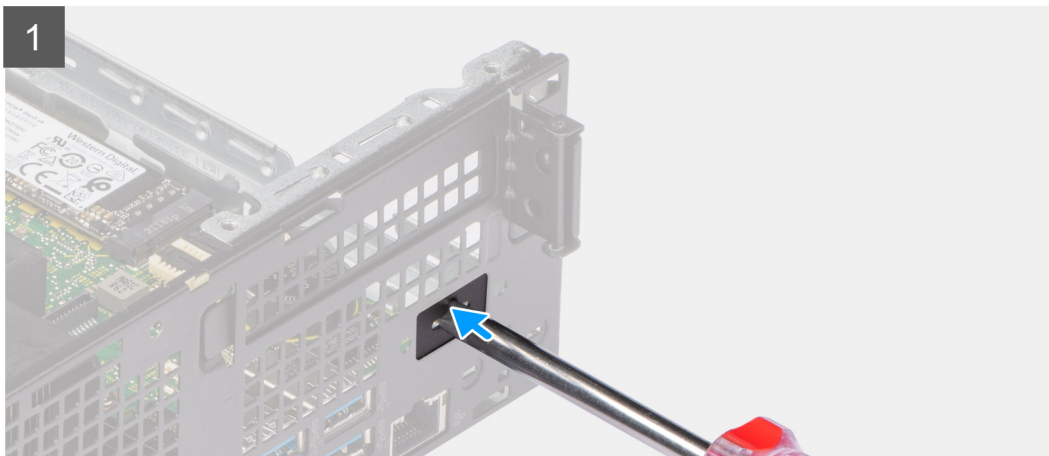
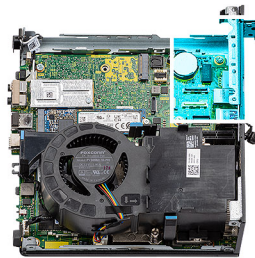

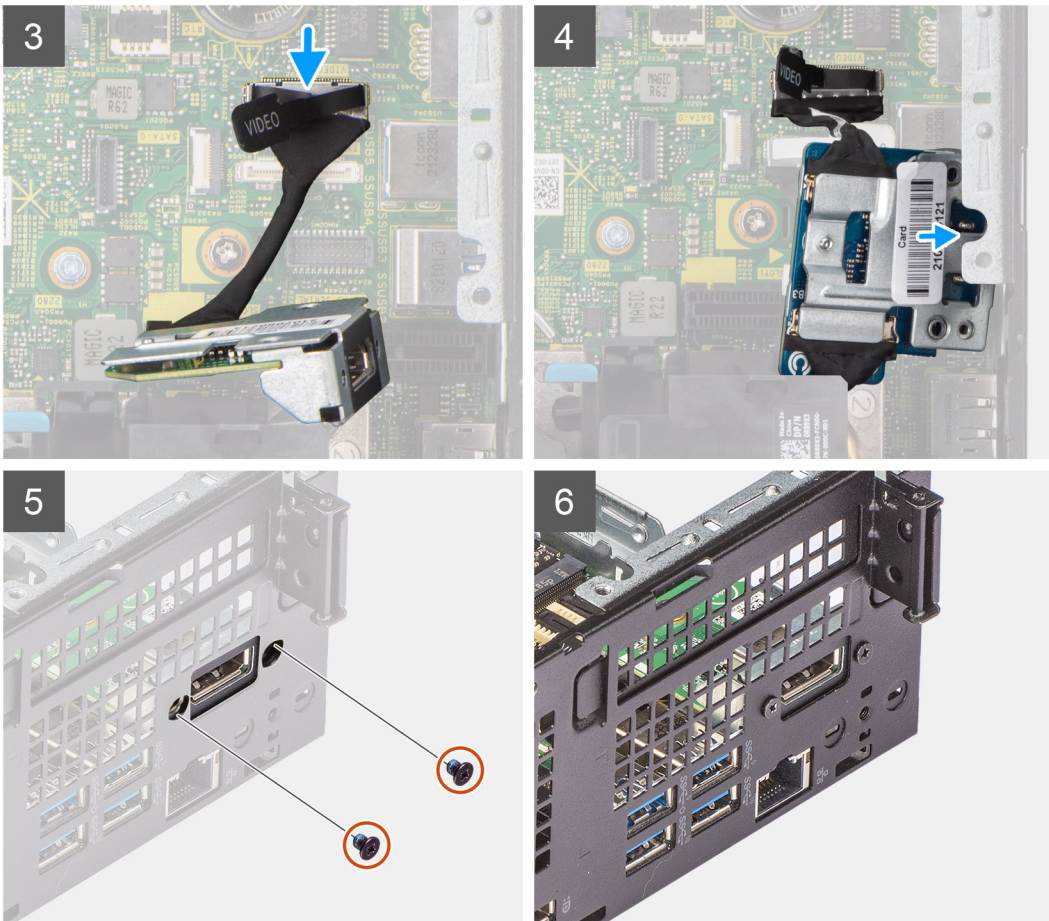

Steps

1. Insert a flat-head screwdriver in the dummy optional-I/O module bracket.
2. Push the bracket to release the bracket from the chassis.
3. Connect the I/O-module cable to the connector on the system board.
4. Insert the I/O module into the slot from the inside your computer.
5. Replace the two screws (M3x3) to secure the optional I/O module to the chassis.

i **NOTE:** The screw type differs with the kind of I/O module used.

6. Place the computer in an upright position.

Next steps

1. Install the [riser card](#).
2. Install the [hard-drive assembly](#).
3. Install the [side cover](#).
4. Follow the procedure in [after working inside your computer](#).

Coin-cell battery

Removing the coin-cell battery

Prerequisites

1. Follow the procedure in [before working inside your computer](#).
2. Remove the [side cover](#).

3. Remove the [riser card](#).
4. Remove the [optional I/O module](#).

NOTE: Removing the coin-cell battery resets the BIOS setup program settings to default. It is recommended that you note the BIOS setup program settings before removing the coin-cell battery.

About this task

The following image(s) indicate the location of the coin-cell battery and provide a visual representation of the removal procedure.

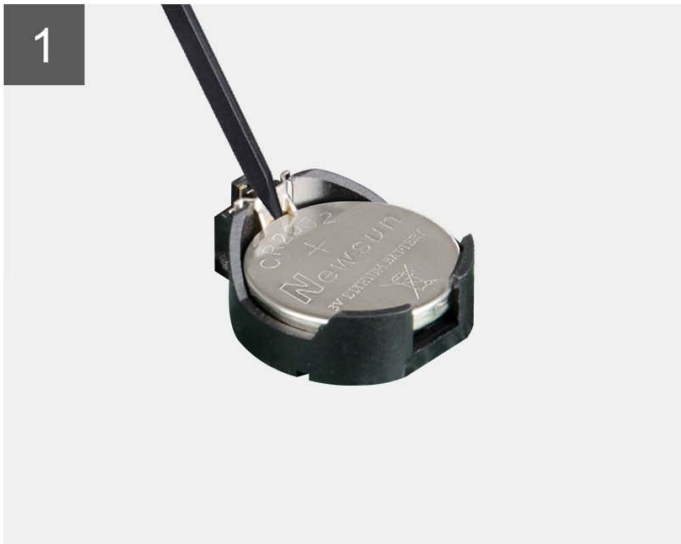
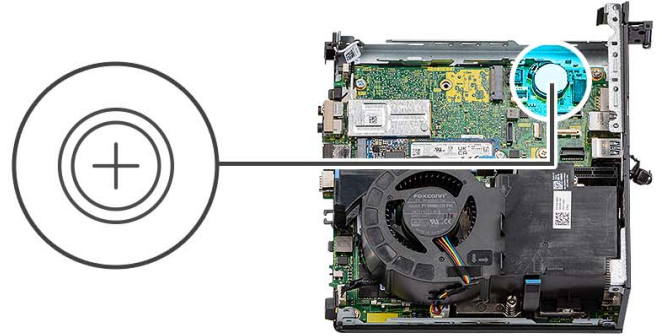

Steps

1. Place the computer on its side with the left side facing up.
2. Using a plastic scribe, push the coin-cell battery securing-clip on the coin-cell battery socket to release the coin-cell battery.
3. Remove the coin-cell battery from the computer.

Installing the coin-cell battery

Prerequisites

If you are replacing a component, remove the existing component before performing the installation procedure.

About this task

The following image(s) indicate the location of the coin-cell battery and provides a visual representation of the installation procedure.

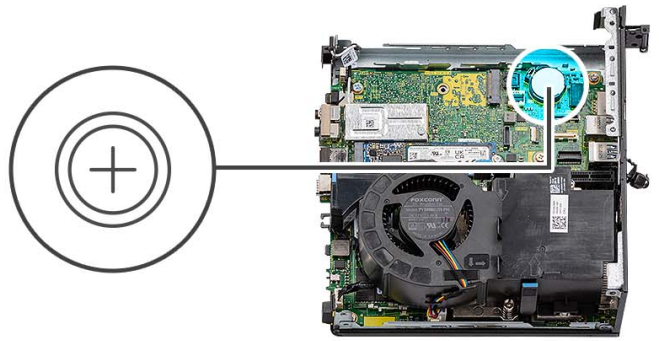

Steps

1. Insert the coin-cell battery into the socket with the positive side (+) label facing up and snap the battery in the socket.
2. Place the computer in an upright position.

Next steps

1. Install the [optional I/O module](#).
2. Install the [riser card](#).
3. Install the [side cover](#).
4. Follow the procedure in [after working inside your computer](#).

Heat sink

Removing the heat sink

Prerequisites

1. Follow the procedure in [before working inside your computer](#).
2. Remove the [side cover](#).
3. Remove the [processor fan](#).

About this task

 **NOTE:** The heat sink may become hot during normal operation. Allow sufficient time for the heat sink to cool before you touch it.

NOTE: For maximum cooling of the processor, do not touch the heat transfer areas on the heat sink. The oils in your skin can reduce the heat transfer capability of the thermal grease.

The following image(s) indicate the location of the heat sink and provide a visual representation of the removal procedure.

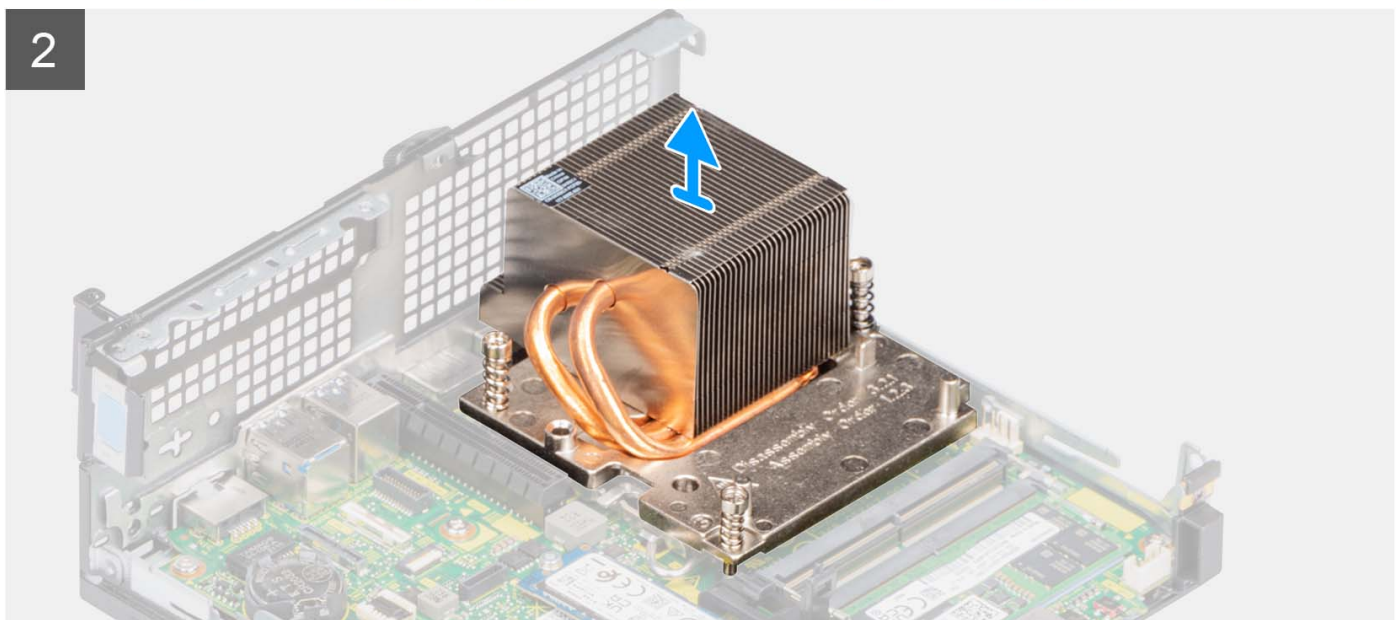
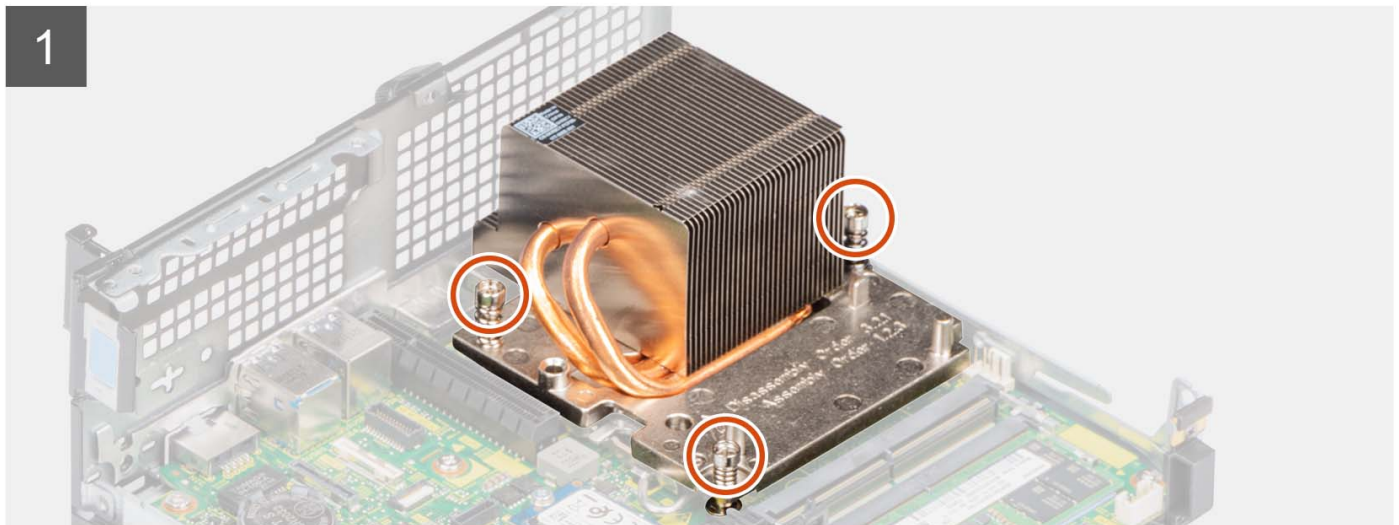
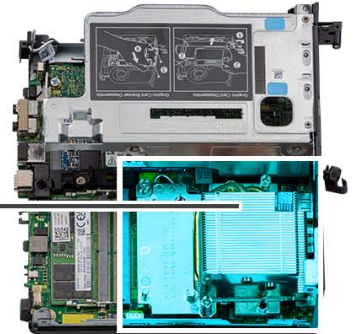
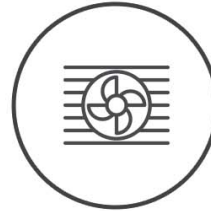

Steps

1. Place the computer on its side with the left side facing up.
2. Loosen the three captive screws in the sequential order (1->3->2) that secure the heat sink to the computer.
3. Lift the heat sink from the system board.

Installing the heat sink

Prerequisites

If you are replacing a component, remove the existing component before performing the installation procedure.

About this task

 **NOTE:** If either the processor or the fan and heat-sink assembly is replaced, use the thermal grease provided in the kit to ensure that thermal conductivity is achieved.

The following image indicates the location of the heat sink and provides a visual representation of the installation procedure.

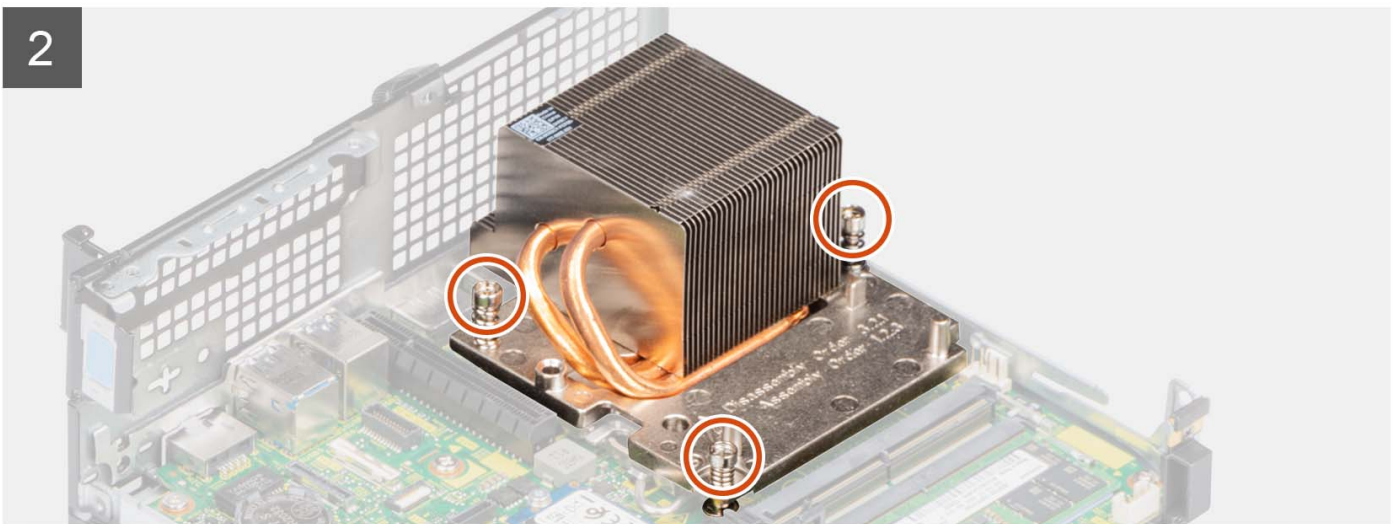
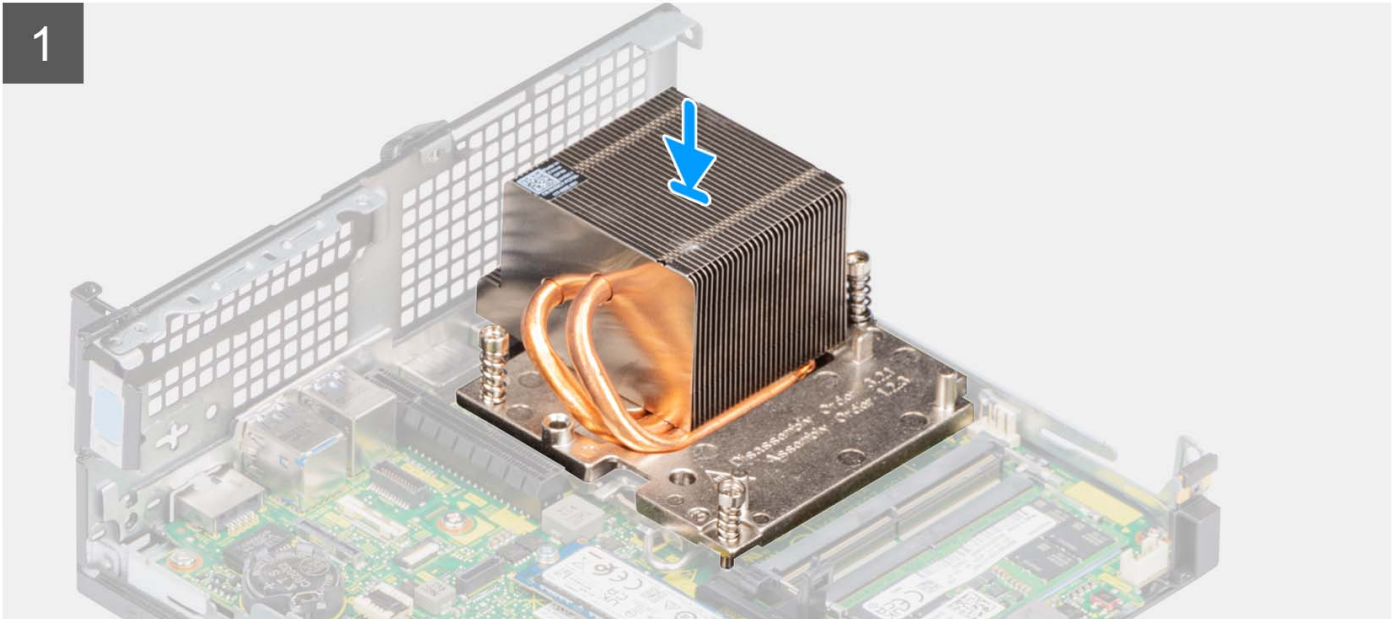
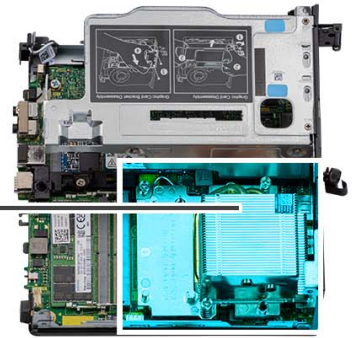
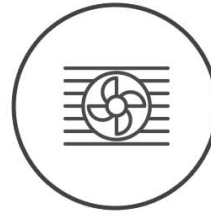

Steps

1. Align the screw holes on the heat sink with the screw holes on the system board.
2. Tighten the three captive screws in a sequential order (1->2->3) to secure the heat sink to the system board.
3. Place the computer in an upright position.

Next steps

1. Install the [processor fan](#).
2. Install the [side cover](#).

3. Follow the procedure in [after working inside your computer](#).

SATA FFC module

Removing the SATA FFC module

Prerequisites

1. Follow the procedure in [before working inside your computer](#).
2. Remove the [side cover](#).
3. Remove the [processor fan](#).
4. Remove the [hard drive](#).

About this task

The following image(s) indicate the location of the SATA FFC module and provide a visual representation of the removal procedure.



1x
M3x5

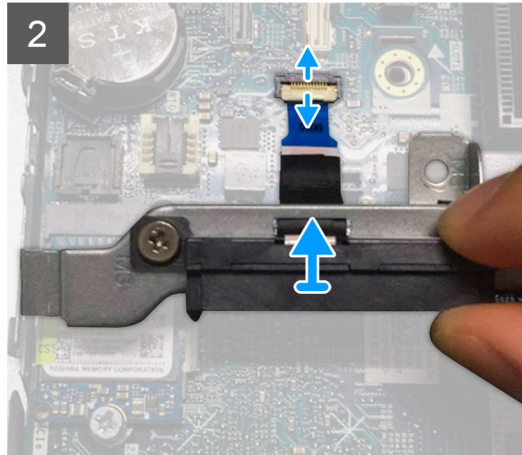
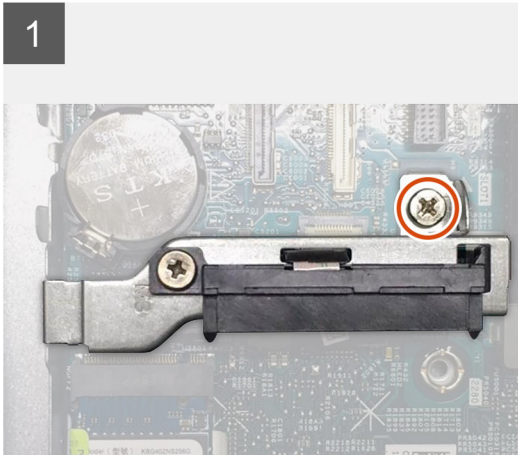

Steps

1. Remove the single screw (M3x5) that secures the SATA interposer module to the system board.
2. Open the latch and disconnect the SATA FFC from the connector on the system board.
3. Lift the SATA FFC module along with the SATA FFC out of the computer.

Installing the SATA FFC module

Prerequisites

If you are replacing a component, remove the existing component before performing the installation procedure.

About this task

The following image(s) indicate the location of the SATA FFC module and provide a visual representation of the installation procedure.



1x
M3x5

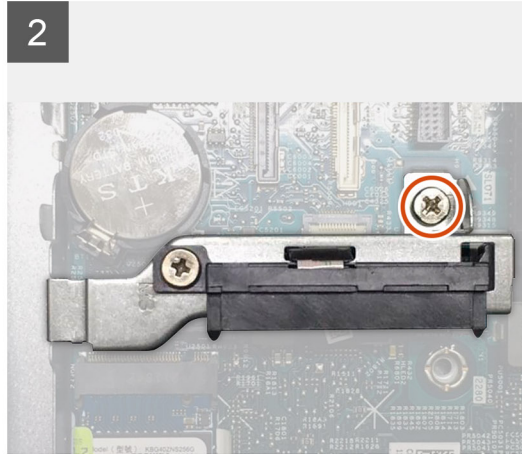
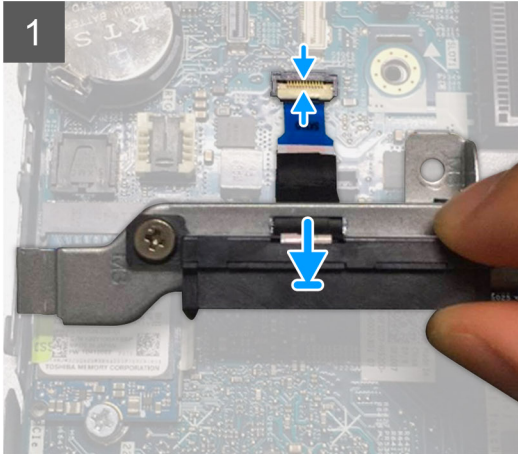

Steps

1. Align the screw hole on the SATA FFC module with the screw hole on the system board.
2. Replace the single screw (M3x5) that secures the SATA FFC module to the system board.
3. Connect the SATA FFC to the connector on the system board and close the latch.

Next steps

1. Install the [hard drive](#).
2. Install the [processor fan](#).
3. Install the [side cover](#).
4. Follow the procedure in [after working inside your computer](#).

Processor

Removing the processor

Prerequisites

1. Follow the procedure in [before working inside your computer](#).
2. Remove the [side cover](#).
3. Remove the [processor fan](#).
4. Remove the [heat sink](#).

About this task

The following image(s) indicate the location of the processor and provide a visual representation of the removal procedure.

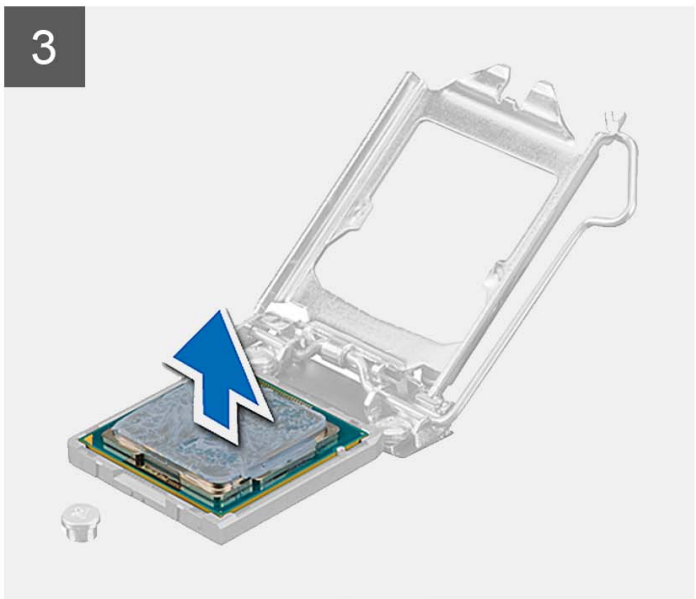
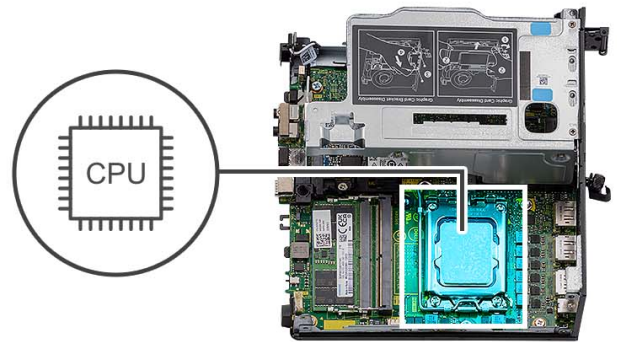

Steps

1. Press the release lever down and then push it away from the processor to release it from the securing tab.
2. Extend the release lever completely and open the processor cover.

 **CAUTION:** When removing the processor, do not touch any of the pins inside the socket or allow any objects to fall on the pins in the socket.

3. Gently lift the processor from the processor socket.

Installing the processor

Prerequisites

If you are replacing a component, remove the existing component before performing the installation procedure.

About this task

The following image(s) indicate the location of the processor and provides a visual representation of the installation procedure.

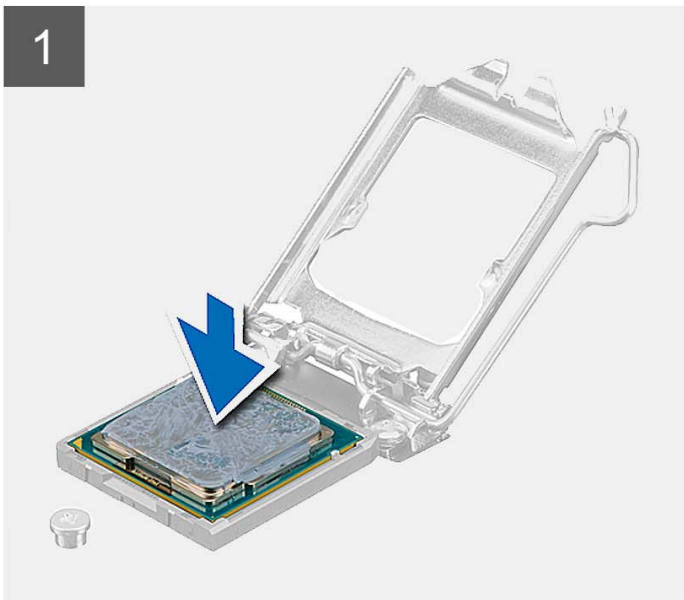
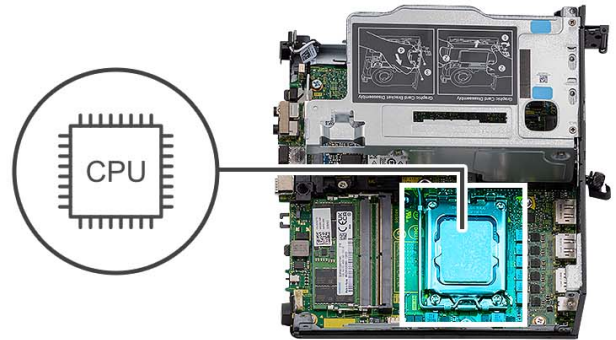

Steps

1. Ensure that the release lever on the processor socket is fully extended in the open position.

i **NOTE:** The pin-1 corner of the processor has a triangle that aligns with the triangle on the pin-1 corner on the processor socket. When the processor is properly seated, all four corners are aligned at the same height. If one or more corners of the processor are higher than the others, the processor is not seated properly.

2. Align the notches on the processor with the tabs on the processor socket and place the processor in the processor socket.

⚠ **CAUTION:** Ensure that the processor-cover notch is positioned underneath the alignment post.

3. When the processor is fully seated in the socket, pivot the release-lever down and place it under the tab on the processor cover.

Next steps

1. Install the [heat sink](#).
2. Install the [processor fan](#).
3. Install the [side cover](#).
4. Follow the procedure in [after working inside your computer](#).

System board

Removing the system board

Prerequisites

1. Follow the procedure in [before working inside your computer](#).
2. Remove the [side cover](#).
3. Remove the [hard-drive assembly](#).
4. Remove the [wireless card](#).
5. Remove the [speaker](#).
6. Remove the [processor fan](#).
7. Remove the [processor](#).
8. Remove the [memory modules](#).
9. Remove the [riser card](#).
10. Remove the [solid-state drive](#).
11. Remove the [optional I/O module](#).
12. Remove the [heat sink](#).
13. Remove the [interposer module](#).
14. Remove the [internal antenna](#).

About this task

The following image indicates the connectors on your system board.

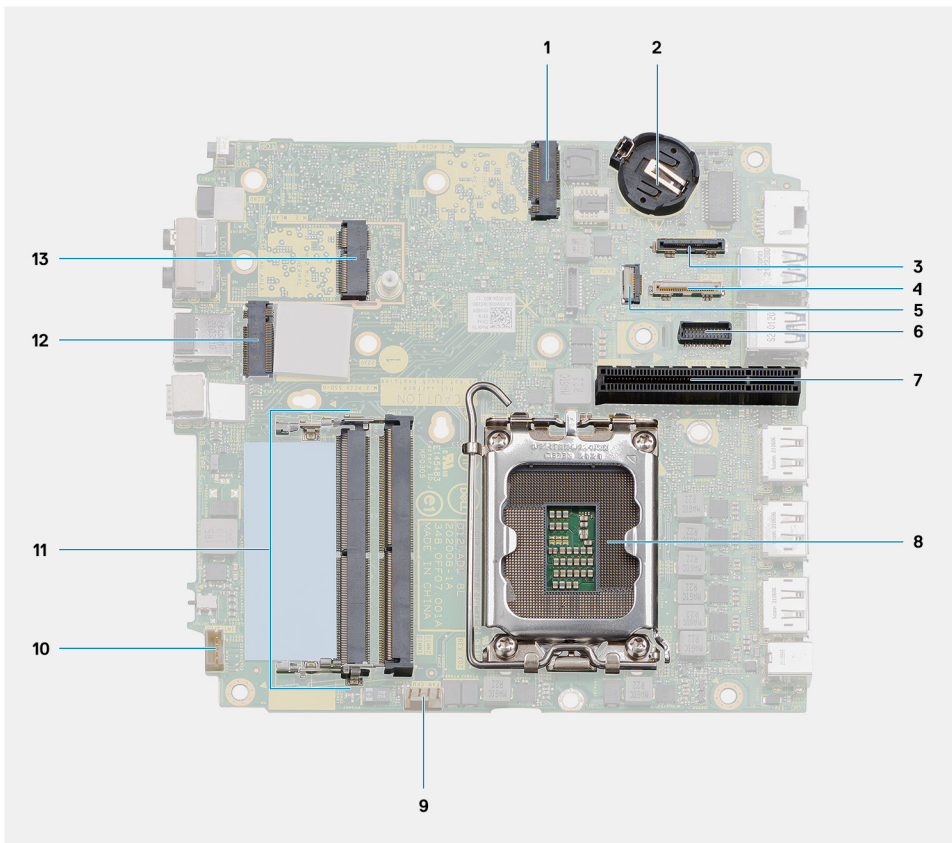

- | | |
|--|---|
| 1. M.2 2230/2280 solid-state drive PCIe connector (SSD-1 slot) | 2. Coin-cell battery |
| 3. Optional video port connector | 4. USB Type-C connector |
| 5. SATA FFC connector | 6. Keyboard and mouse serial port connector |
| 7. PCIe x8 Gen4 slot | 8. Processor |
| 9. Processor fan connector | 10. Internal speaker connector |
| 11. Memory modules | 12. M.2 2230/2280 solid-state drive PCIe connector (SSD-0 slot) |
| 13. M.2 WLAN connector | |

The following image(s) indicate the location of the system board and provide a visual representation of the removal procedure.

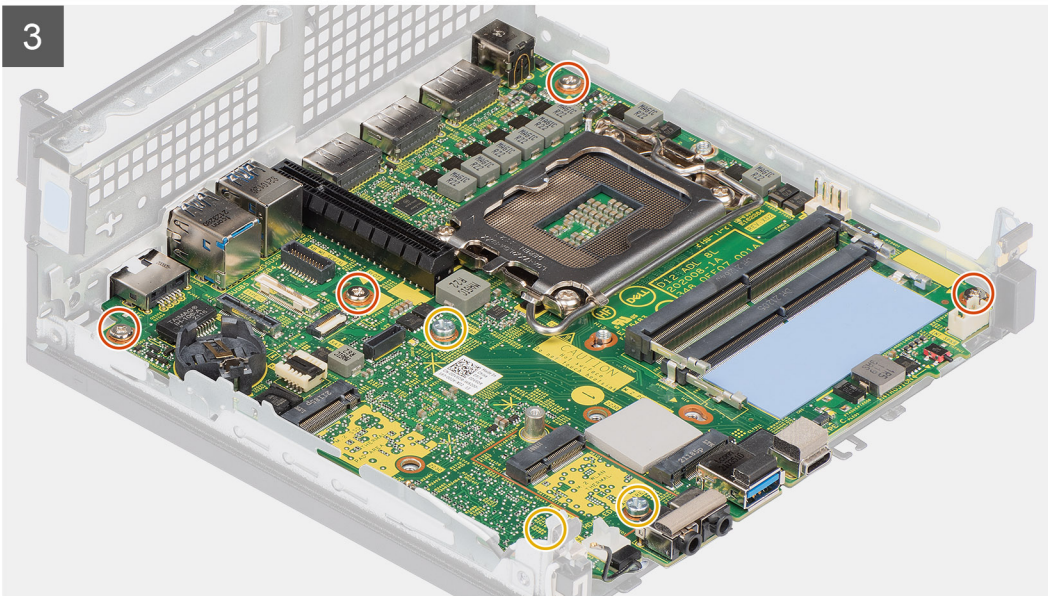
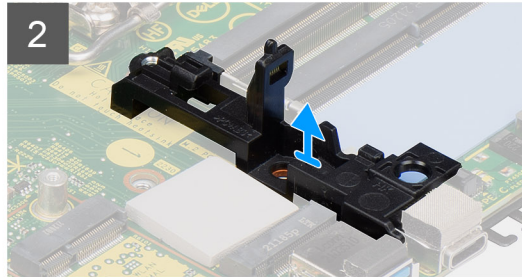
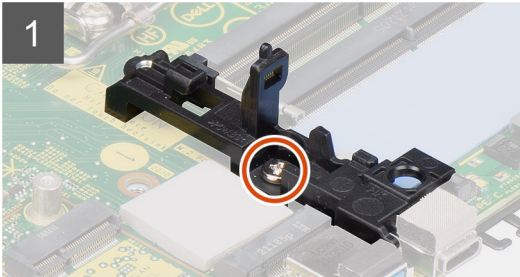
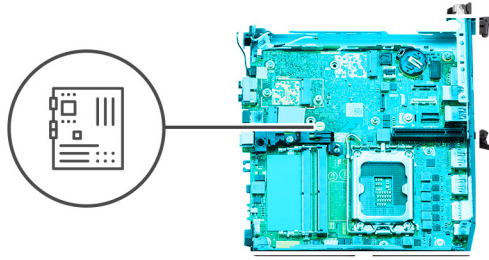
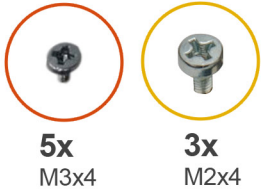

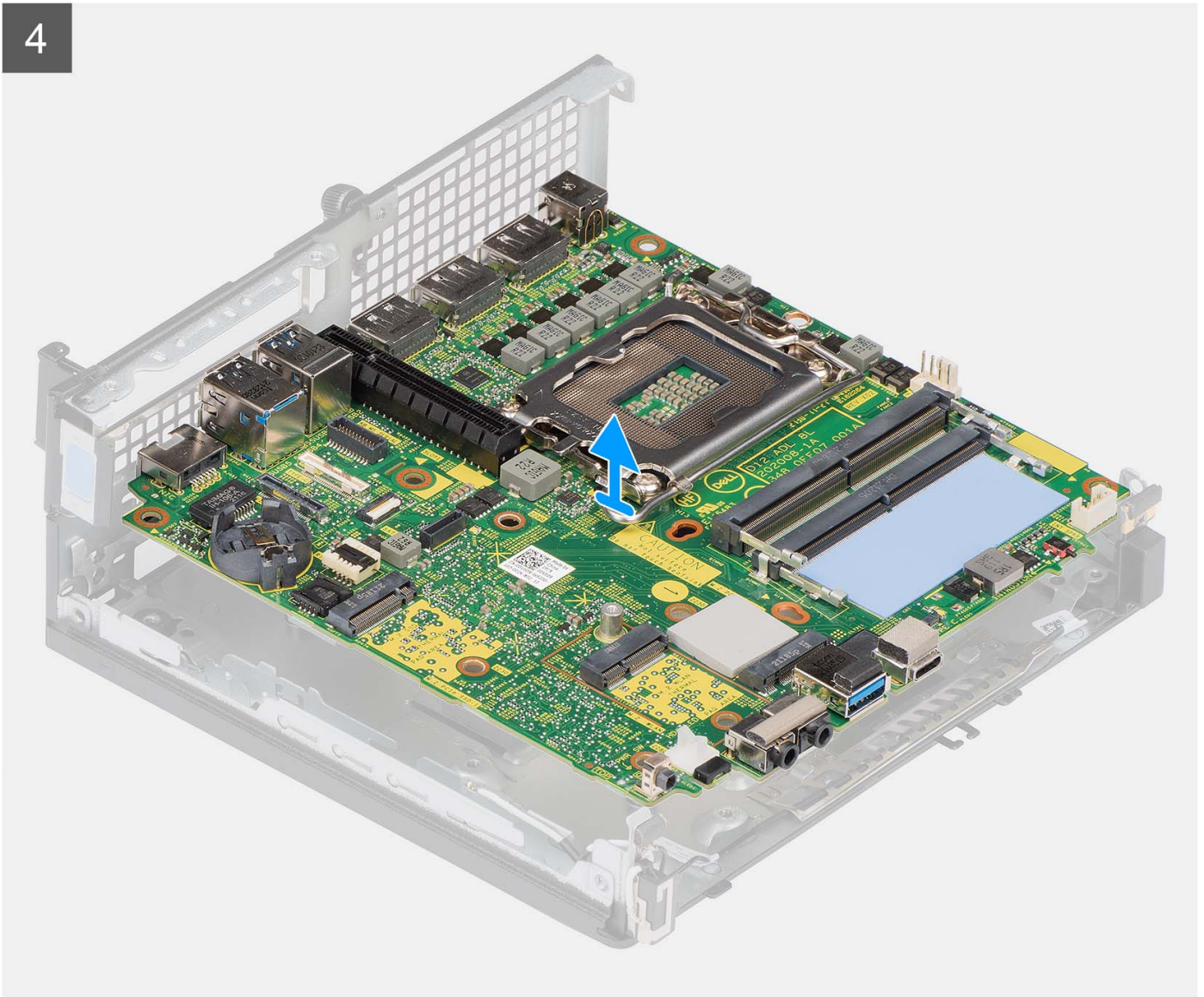

Steps

1. Remove the single screw (M3x4) that secures the speaker holder to the system board.
2. Lift and remove the speaker holder away from the system board.
3. Remove the four screws (M3x4) that secure the system board to the chassis.
4. Remove the three screws (M2x4) that secure the system board to the chassis.
5. Slide and lift the system board away from the chassis.

Installing the system board

Prerequisites

If you are replacing a component, remove the existing component before performing the installation procedure.

About this task

The following image indicates the connectors on your system board.

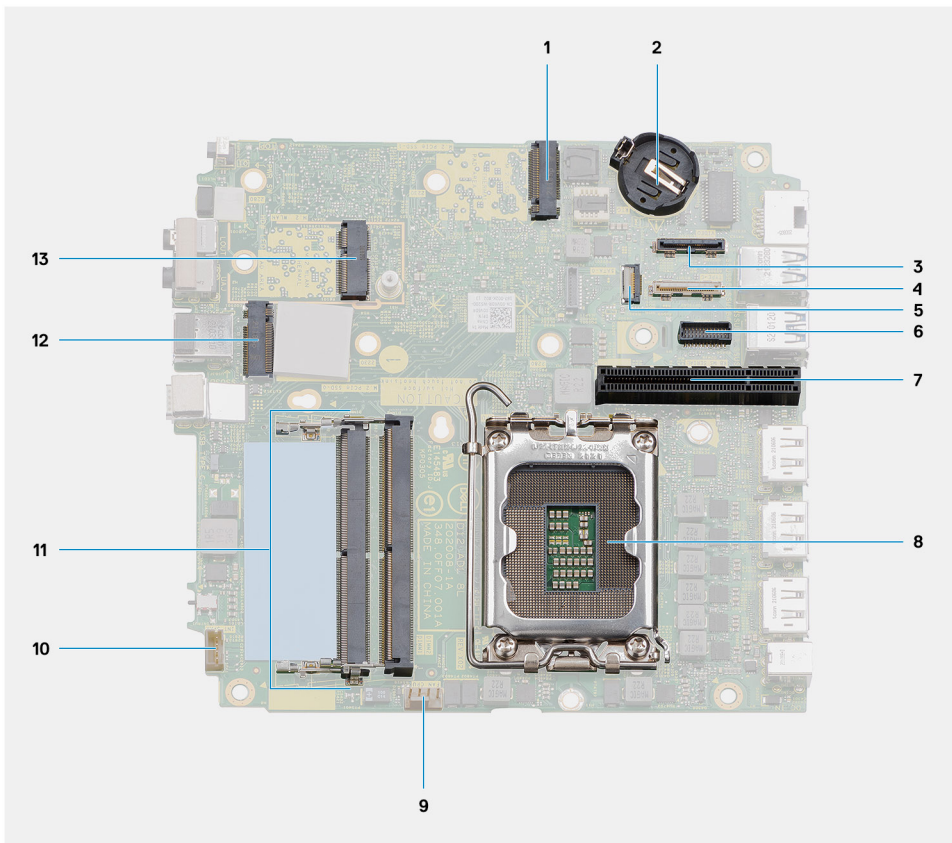

- | | |
|--|---|
| 1. M.2 2230/2280 solid-state drive PCIe connector (SSD-1 slot) | 2. Coin-cell battery |
| 3. Optional video port connector | 4. USB Type-C connector |
| 5. SATA FFC connector | 6. Keyboard and mouse serial port connector |
| 7. PCIe x8 Gen4 slot | 8. Processor |
| 9. Processor fan connector | 10. Internal speaker connector |
| 11. Memory modules | 12. M.2 2230/2280 solid-state drive PCIe connector (SSD-0 slot) |
| 13. M.2 WLAN connector | |

The following image(s) indicate the location of the system board and provide a visual representation of the installation procedure.



5x
M3x4



3x
M2x4

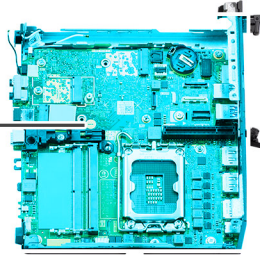

1

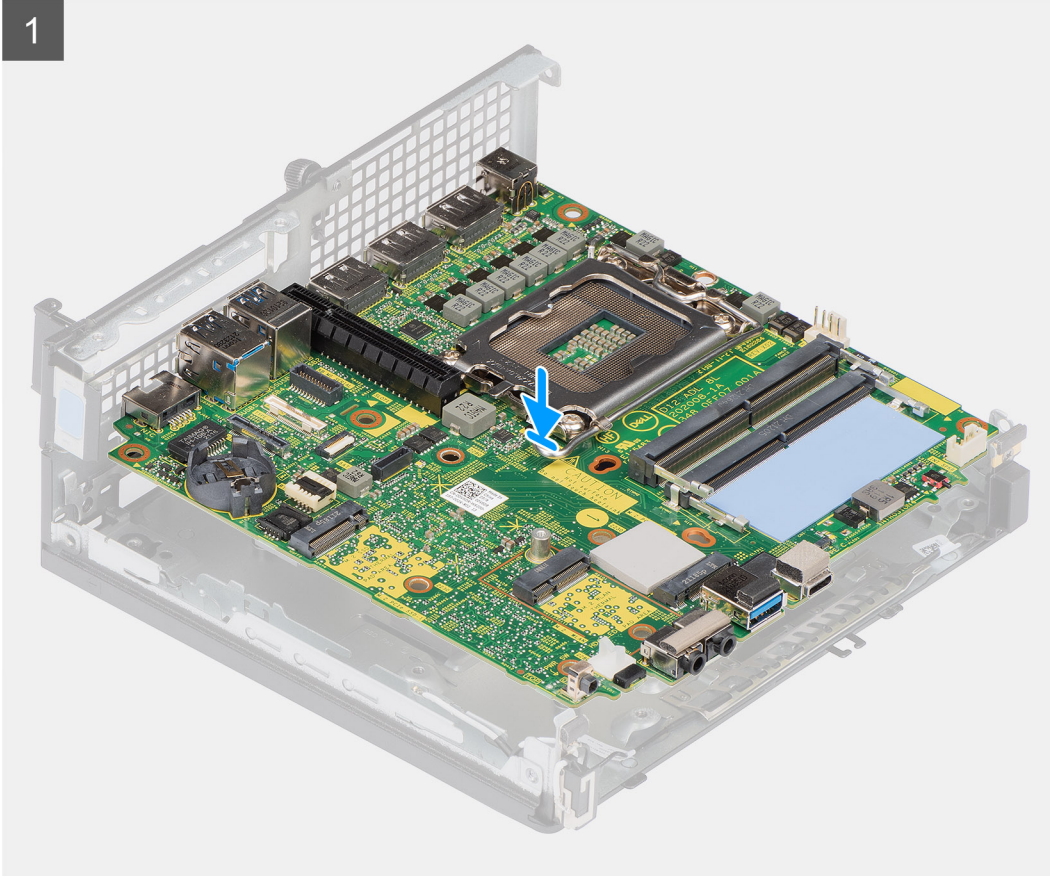

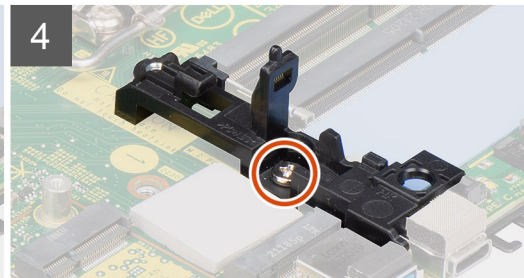
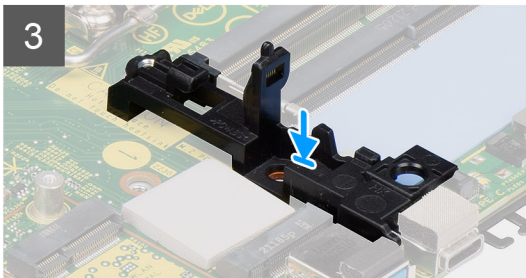
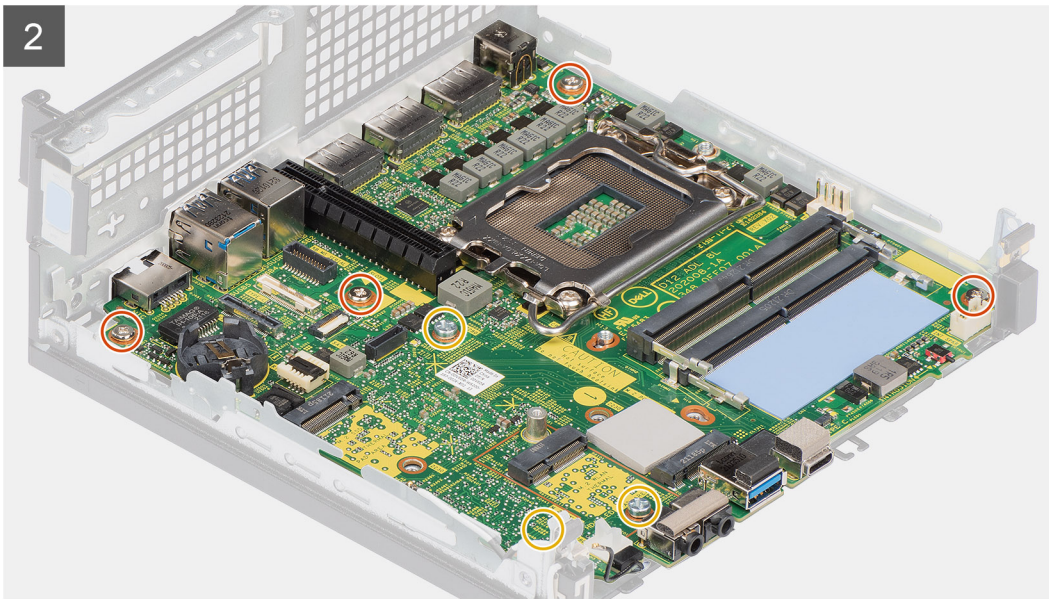

Steps

1. Align the screw holes on the system board with screw holes on the chassis.
2. Replace the three screws (M2x4) to secure the system board to the chassis.
3. Replace the three screws (M3x4) to secure the system board to the chassis.
4. Align the screw hole on the speaker holder with the screw hole on the system board.
5. Replace the single screw (M3x4) to secure the speaker holder to the system board.

Next steps

1. Install the [internal antenna](#)
2. Install the [interposer module](#).
3. Install the [heat sink](#).
4. Install the [optional I/O module](#).
5. Install the [solid-state drive](#).
6. Install the [riser card](#).
7. Install the [memory modules](#).
8. Install the [processor fan](#).
9. Install the [processor](#).
10. Install the [speaker](#).
11. Install the [wireless card](#).
12. Install the [hard-drive assembly](#).
13. Install the [side cover](#).
14. Follow the procedure in [after working inside your computer](#).

Internal antennae

Removing the internal antenna—location 1

Prerequisites

1. Follow the procedure in [before working inside your computer](#).
2. Remove the [side cover](#).
3. Remove the [hard-drive assembly—optional](#).
4. Remove the [riser card—optional](#).
5. Remove the [wireless card](#).

About this task

The following image(s) indicate the location of the internal antenna and provide a visual representation of the removal procedure.



1x
M3x3

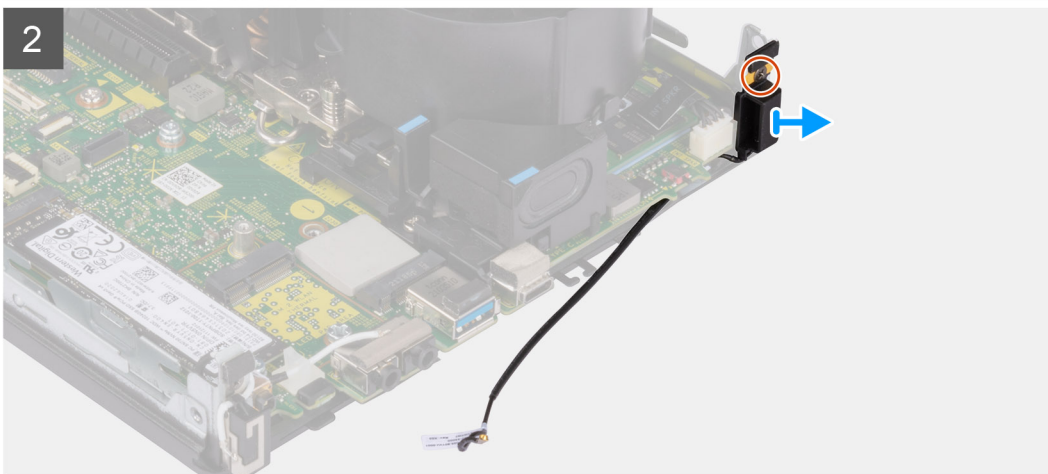
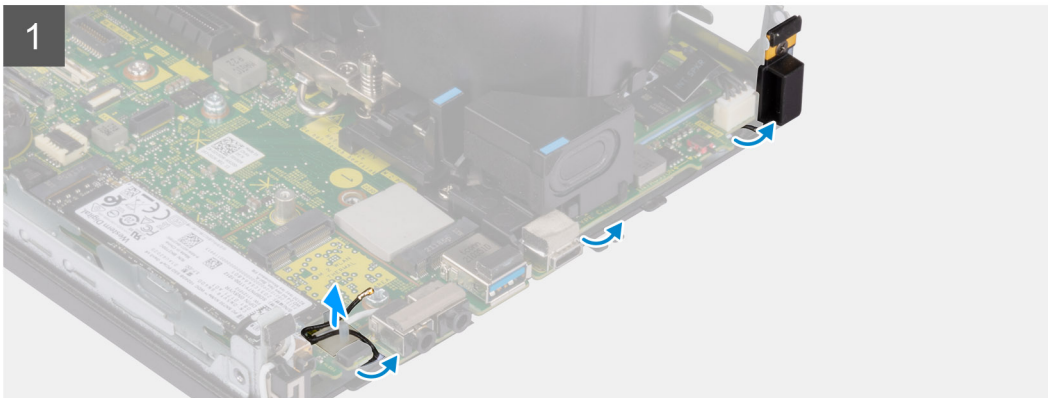
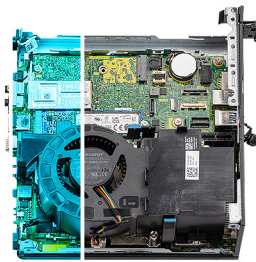

Steps

1. Unroute the antenna cable from the routing guides under the EMI shielding along with the chassis using a plastic scribe.

2. Remove the antenna cable from the securing clip on the computer.
3. Remove the single (M3x3) screw that secures the internal antenna to the chassis.
4. Remove the antenna holder ribs from the holes on the chassis.
5. Lift the internal antenna module away from the chassis.

Installing the internal antenna—location 1

Prerequisites

If you are replacing a component, remove the existing component before performing the installation procedure.

About this task

The following image indicates the location of the Internal antenna and provides a visual representation of the installation procedure.



1x
M3x3

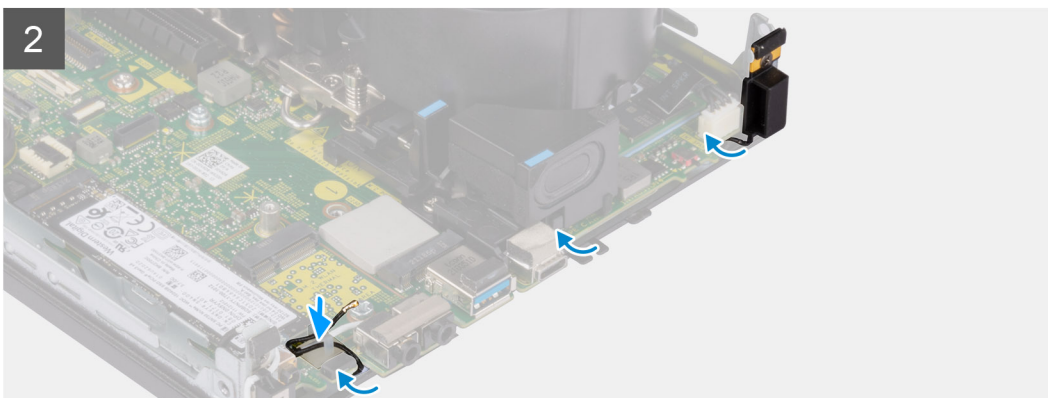
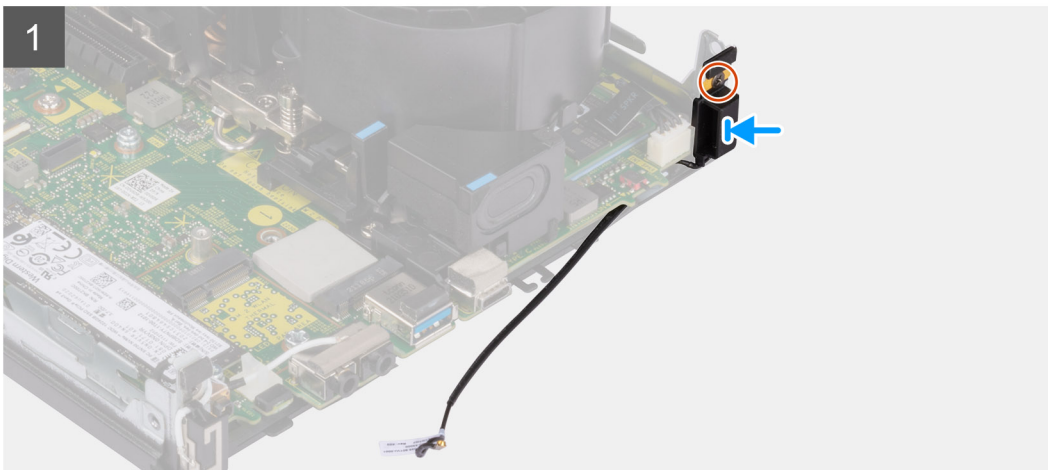
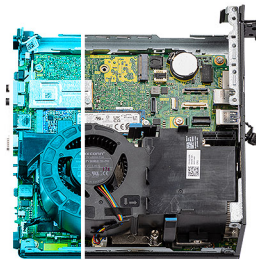

Steps

1. Remove the Aux antenna-cable adhesive tape.
2. Align the screw holes on the chassis with screw hole on the internal antenna module.
3. Insert the antenna holder ribs into the holes on the chassis.

4. Replace the single (M3x3) screw to secure the internal antennae to the chassis.
5. Replace the antenna cable into securing clip on the computer.
6. Route the antenna cable through the metallic routing guides under the EMI shielding along with the chassis using a plastic scribe.

Next steps

1. Install the [wireless card](#).
2. Install the [riser card—optional](#).
3. Install the [hard-drive assembly—optional](#).
4. Install the [side cover](#).
5. Follow the procedure in [after working inside your computer](#).

Removing the internal antenna—location 2

Prerequisites

1. Follow the procedure in [before working inside your computer](#).
2. Remove the [side cover](#).
3. Remove the [hard-drive assembly—optional](#).
4. Remove the [riser card—optional](#).
5. Remove the [wireless card](#).

About this task

The following image(s) indicate the location of the internal antenna and provide a visual representation of the removal procedure.



1x
M3x3

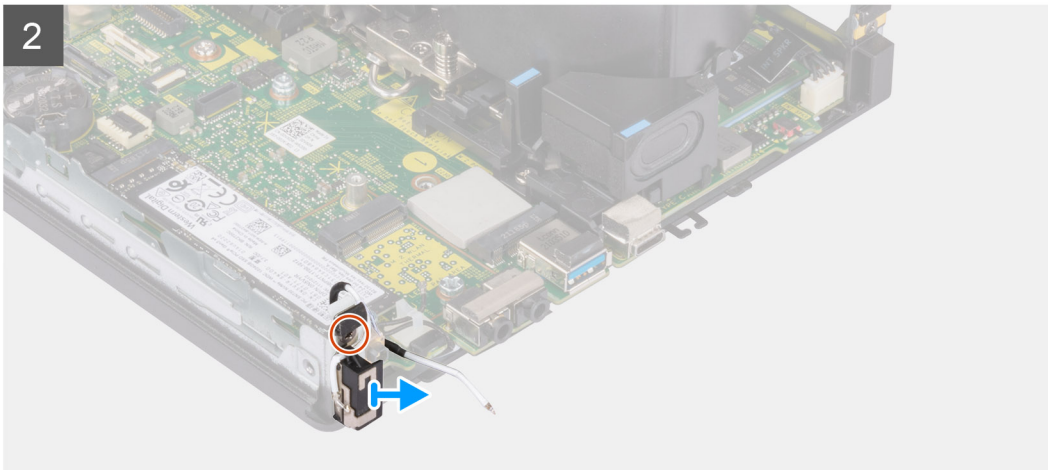
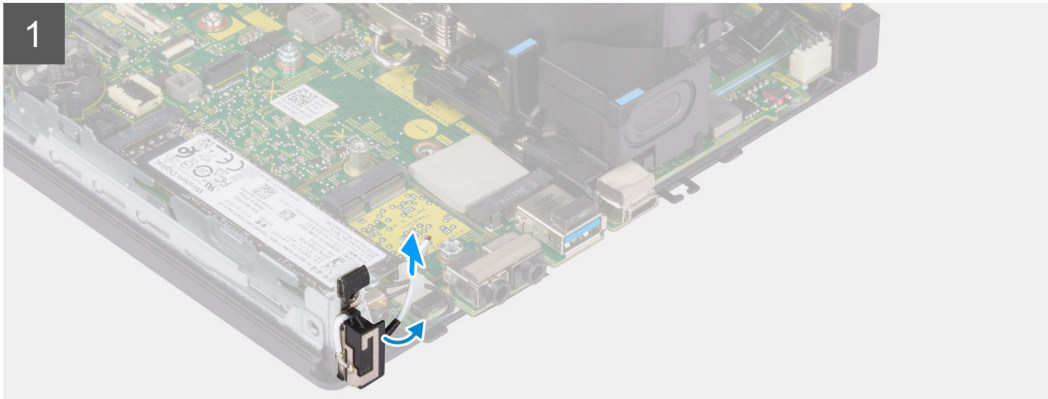
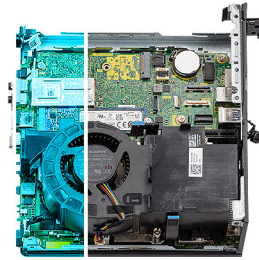

Steps

1. Pry the metallic routing guide and unroute the antenna cables from the chassis.
2. Remove the single screw (M3x3) that secures the internal antennae to the chassis.
3. Lift and remove the internal antennae away from the computer.

Installing the internal antenna—location 2

Prerequisites

If you are replacing a component, remove the existing component before performing the installation procedure.

About this task

The following image indicates the location of the Internal antenna and provides a visual representation of the installation procedure.



1x
M3x3

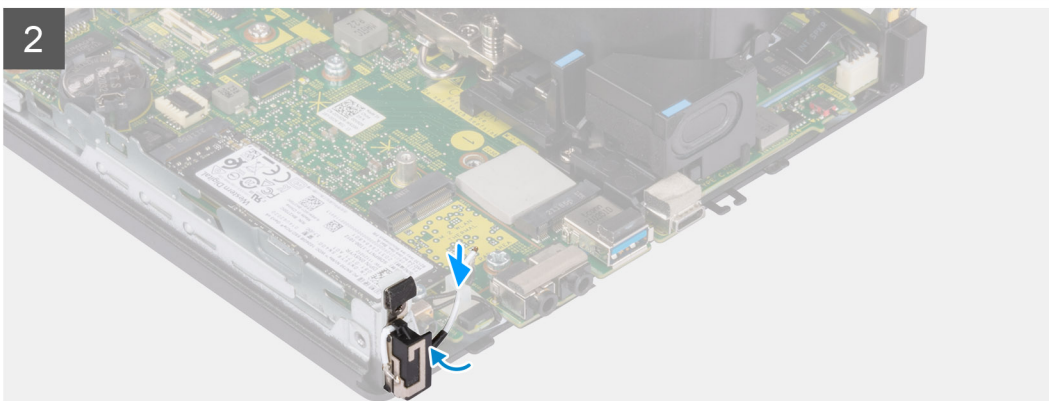
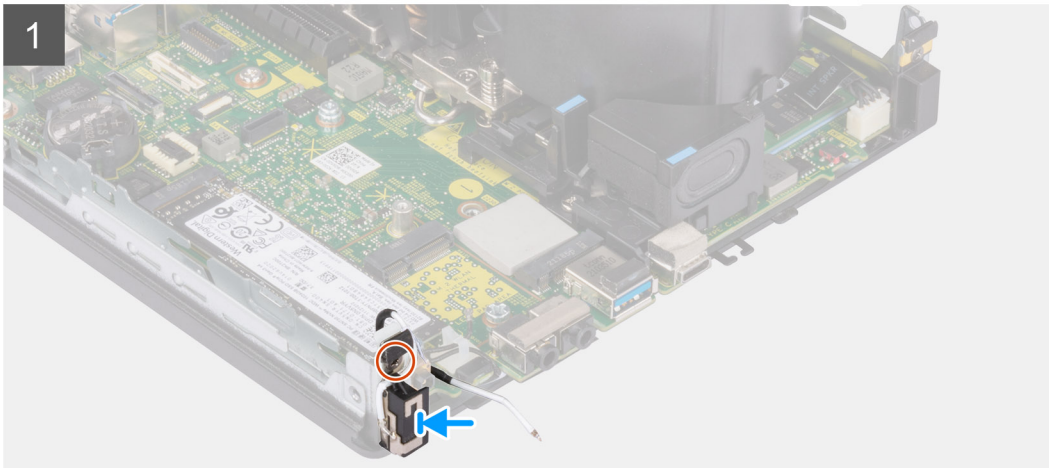
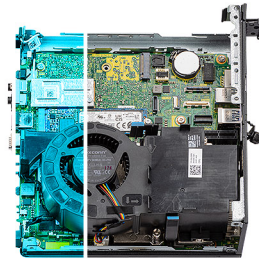

Steps

1. Remove adhesive tape and place the Aux antenna stand off into the hole on the chassis.
2. Align the antenna module screw hole with the screw hole on the chassis.
3. Replace the single screw (M3x3) to secure the internal antennae to the chassis.
4. Route the antenna cable through the metallic routing guide on the computer.

Next steps

1. Install the [wireless card](#).
2. Install the [riser card](#)—optional.
3. Install the [hard-drive assembly](#)—optional.
4. Install the [side cover](#).
5. Follow the procedure in [after working inside your computer](#).

Removing the SMA antenna—Location 3

Prerequisites

1. Follow the procedure in [before working inside your computer](#).
2. Remove the [side cover](#).

3. Remove the [hard-drive assembly](#)—optional.
4. Remove the [riser card](#)—optional.

About this task

The following images indicate the location of the SMA antenna and provide a visual representation of the removal procedure.

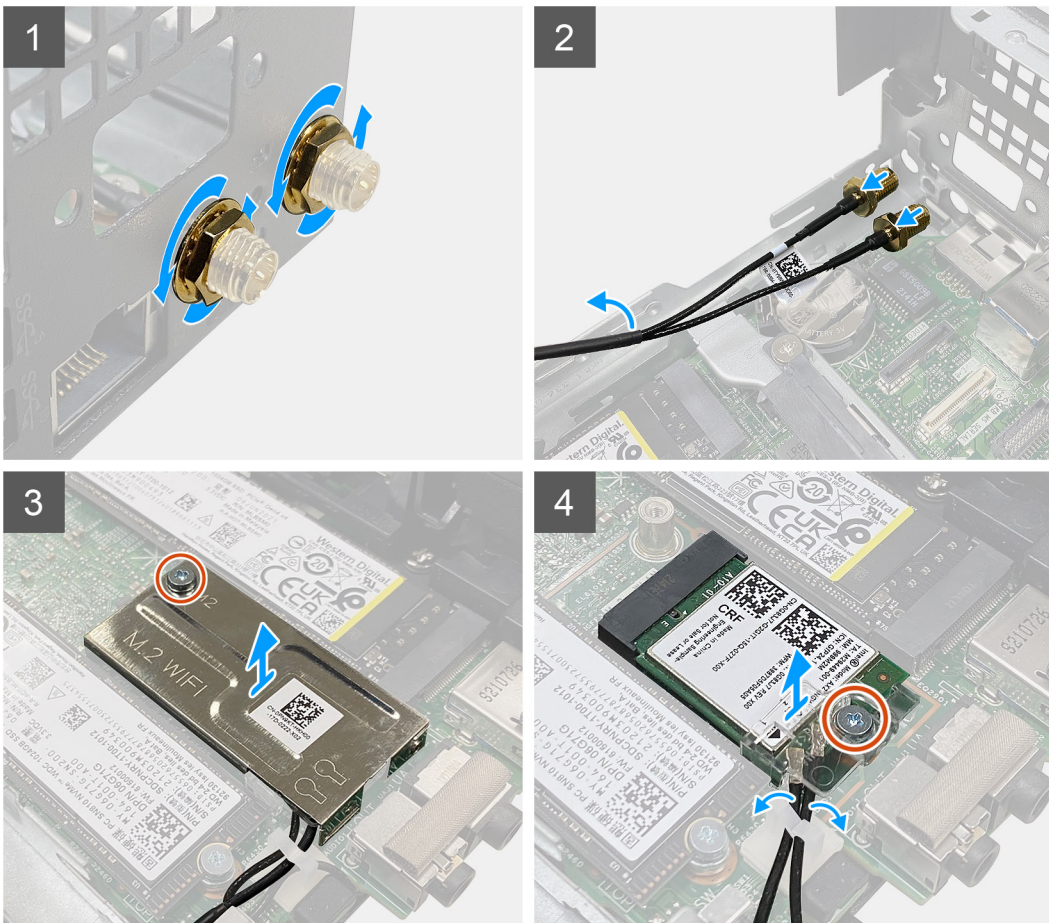
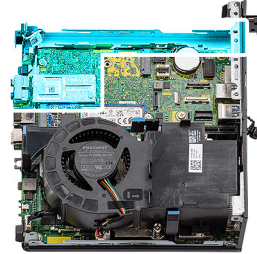

Steps

1. Remove the cable-protective cover from the SMA antenna.
2. Loosen the nut using the 8 mm wrench or with automatic screw driver.
3. Remove the SMA antenna module out of the chassis.
4. Remove the single (M2x3.5) screw that secures the wireless-card shield to the system board.
5. Remove the wireless-card shield away from the wireless card.
6. Unroute the antenna cables from the routing guides on the sides of the system board.
7. Remove the (M2x3.5) screw that secures the wireless-card bracket to the wireless card.
8. Disconnect the antenna cables from the connectors on the wireless card.
9. Slide and remove the wireless card away from the system board.
10. Unroute the location 1 and location 2 internal antenna cables from the securing clip on the chassis.

Installing the SMA antenna—Location 3

Prerequisites

If you are replacing a component, remove the existing component before performing the installation procedure.

About this task

The following image indicates the location of the SMA antenna and provides a visual representation of the installation procedure.

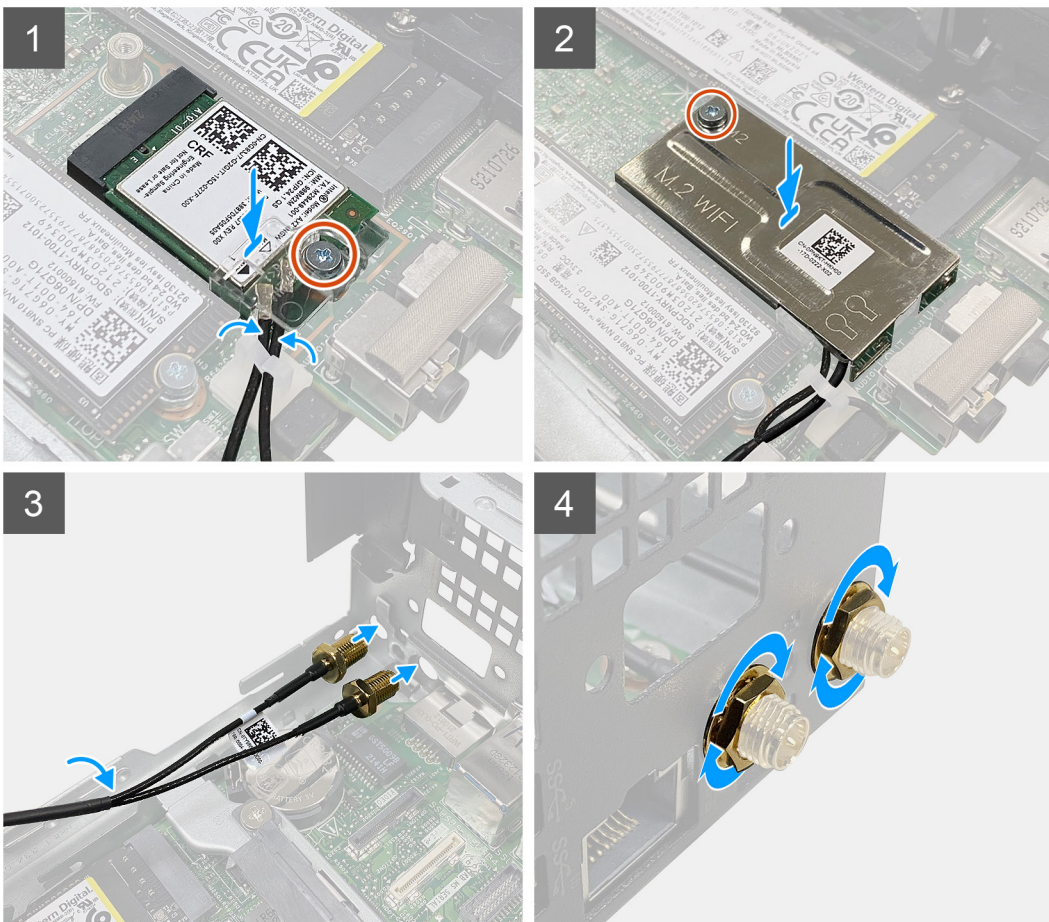
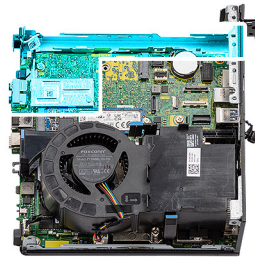

Steps

1. Route the location1 and location 2 internal antenna cables through the securing clip on the chassis.
2. Connect the antenna cables to the wireless card.
3. Place the wireless-card bracket to secure the antenna cables.
4. Align the notch on the wireless card with the tab on the wireless-card slot. Insert the wireless card into the connector on the system board.
5. Replace the (M2x3.5) screw to secure the wireless-card bracket to the wireless card.
6. Align and place the wireless-card shield on the wireless card.
7. Replace the single (M2x3.5) screw to secure the wireless-card shield to the system board.

8. Route the antenna cables through the routing guides on the sides of the system board.
9. Remove the cable-protective cover from the SMA antenna.
10. Use a screwdriver to remove the upper filler in the SMA antenna holes on the chassis.
11. Insert the SMA antenna module through the bottom cover inside the chassis.
12. Tighten the nut using the 8 mm wrench or with automatic screw driver.
13. Replace the cable-protective cover to the SMA antenna.

Next steps

1. Install the [riser card—optional](#).
2. Install the [hard-drive assembly—optional](#).
3. Install the [side cover](#).
4. Follow the procedure in [after working inside your computer](#).

Drivers and downloads

When troubleshooting, downloading or installing drivers it is recommended that you read the Dell Knowledge Based article, Drivers and Downloads FAQ [000123347](#).

BIOS setup

CAUTION: Unless you are an expert computer user, do not change the settings in the BIOS Setup program. Certain changes can make your computer work incorrectly.

NOTE: Depending on the computer and its installed devices, the items listed in this section may or may not be displayed.

NOTE: Before you change BIOS Setup program, it is recommended that you write down the BIOS Setup program screen information for future reference.

Use the BIOS Setup program for the following purposes:

- Get information about the hardware installed in your computer, such as the amount of RAM and the size of the hard drive.
- Change the system configuration information.
- Set or change a user-selectable option, such as the user password, type of hard drive installed, and enabling or disabling base devices.

Entering BIOS setup program

About this task

Turn on (or restart) your computer and press F2 immediately.

Navigation keys

NOTE: For most of the System Setup options, changes that you make are recorded but do not take effect until you restart the system.

Table 3. Navigation keys

Keys	Navigation
Up arrow	Moves to the previous field.
Down arrow	Moves to the next field.
Enter	Selects a value in the selected field (if applicable) or follow the link in the field.
Spacebar	Expands or collapses a drop-down list, if applicable.
Tab	Moves to the next focus area. NOTE: For the standard graphics browser only.
Esc	Moves to the previous page until you view the main screen. Pressing Esc in the main screen displays a message that prompts you to save any unsaved changes and restarts the system.

One time boot menu

To enter **one time boot menu**, turn on your computer, and then press F12 immediately.

NOTE: It is recommended to shutdown the computer if it is on.

The one-time boot menu displays the devices that you can boot from including the diagnostic option. The boot menu options are:

- Removable Drive (if available)
- STXXXX Drive (if available)
- **i** **NOTE:** XXX denotes the SATA drive number.
- Optical Drive (if available)
- SATA Hard Drive (if available)
- Diagnostics

The boot sequence screen also displays the option to access the System Setup screen.

System setup options

i **NOTE:** Depending on your system and its installed devices, the items that are listed in this section may or may not appear.

Table 4. System setup options—System information menu

Overview	
Latitude 3320	
BIOS Version	Displays the BIOS version number.
Service Tag	Displays the Service Tag of the system.
Asset Tag	Displays the Asset Tag of the system.
Manufacture Date	Displays the manufacture date of the system.
Ownership Date	Displays the ownership date of the system.
Express Service Code	Displays the express service code of the system.
Ownership Tag	Displays the Ownership Tag of the system.
Signed Firmware Update	Displays whether the Signed Firmware Update is enabled on your system.
Battery Information	
Primary	Displays that battery is primary.
Battery Level	Displays the battery level of the system.
Battery State	Displays the battery state of the system.
Health	Displays the battery health of the system.
AC Adapter	Displays whether the AC adapter is connected or not.
Processor Information	
Processor Type	Displays the processor type.
Maximum Clock Speed	Displays the maximum processor clock speed.
Minimum Clock Speed	Displays the minimum processor clock speed.
Current Clock Speed	Displays the current processor clock speed.
Core Count	Displays the number of cores on the processor.
Processor ID	Displays the processor identification code.
Processor L2 Cache	Displays the processor L2 Cache size.
Processor L3 Cache	Displays the processor L3 Cache size.
Microcode Version	Displays the microcode version.
Intel Hyper-Threading Capable	Displays whether the processor is Hyper-Threading (HT) capable.
64-Bit Technology	Displays whether 64-bit technology is used.

Table 4. System setup options—System information menu (continued)

Overview	
Memory Information	
Memory Installed	Displays the total system memory installed.
Memory Available	Displays the total system memory available.
Memory Speed	Displays the memory speed.
Memory Channel Mode	Displays single or dual channel mode.
Memory Technology	Displays the technology that is used for the memory.
Devices Information	
Panel Type	Displays the Panel Type of the system.
Video Controller	Displays the video controller type of the system.
Video Memory	Displays the video memory information of the system.
Wi-Fi Device	Displays the wireless device information of the system.
Native Resolution	Displays the native resolution of the system.
Video BIOS Version	Displays the video BIOS version of the system.
Audio Controller	Displays the audio controller information of the system.
Bluetooth Device	Displays the Bluetooth device information of the system.

Table 5. System setup options—Boot Configuration menu

Boot Configuration	
Boot Sequence	
Boot mode	Displays the boot mode.
Boot Sequence	Displays the boot sequence.
Secure Digital (SD) Card Boot	Enable or disable the SD card read-only boot. By default, the Secure Digital (SD) Card Boot option is not enabled.
Secure Boot	
Enable Secure Boot	Enable or disable the secure boot feature. By default, the option is not enabled.
Secure Boot Mode	Enable or disable to change the secure boot mode options. By default, the Deployed Mode is enabled.
Expert Key Management	
Enable Custom Mode	Enable or disable custom mode. By default, the custom mode option is not enabled.
Custom Mode Key Management	Select the custom values for expert key management.

Table 6. System setup options—Integrated Devices menu

Integrated Devices	
Date/Time	Displays the current date in MM/DD/YYYY format and current time in HH:MM:SS AM/PM format.
Camera	Enables or disable the camera. By default, the Enable Camera option is selected
Audio	

Table 6. System setup options—Integrated Devices menu (continued)

Integrated Devices	
Enable Audio	Enable or disable the integrated audio controller. By default, all the options are enabled.
USB Configuration	<ul style="list-style-type: none"> Enable or disable booting from USB mass storage devices that are connected to external USB ports. By default, the Enable External USB Ports option is enabled. Enable or disable booting from USB mass storage devices such as external hard drive, optical drive, and USB drive. By default, the Enable USB Boot Support option is enabled.
Disable USB4 PCIE Tunneling	Disable the USB4 PCIE Tunneling option. By default, the option is disabled.
Video/Power only on Type-C Ports	Enable or disable the Type-C port functionality to video or power only. By default, the Video/Power only on Type-C Ports option is disabled.

Table 7. System setup options—Storage menu

Storage	
SATA/NVMe Operation	
SATA/NVMe Operation	Set the operating mode of the integrated storage device controller. By default, the RAID On option is enabled.
Storage interface	
Port Enablement	This page allows you to enable the onboard drives. By default, the M.2 PCIe SSD option is enabled.
SMART Reporting	
Enable SMART Reporting	Enable or disable Self-Monitoring, Analysis, and Reporting Technology (SMART) during system startup. By default, the Enable SMART Reporting option is not enabled.
Drive Information	
M.2 PCIe SSD	
Type	Displays the M.2 PCIe SSD type information of the system.
Device	Displays the M.2 PCIe SSD device information of the system.
Enable MediaCard	
Secure Digital (SD) Card	Enable or disable the SD card. By default, the Secure Digital (SD) Card option is enabled.
Secure Digital (SD) Card Read-Only Mode	Enable or disable the SD card read-only mode. By default, the Secure Digital (SD) Card Read-Only Mode option is not enabled.

Table 8. System setup options—Display menu

Display	
Display Brightness	
Brightness on battery power	Enable to set screen brightness when the system is running on battery power.
Brightness on AC power	Enable to set screen brightness when the system is running on AC power.

Table 8. System setup options—Display menu (continued)

Display	
EcoPower	<p>Enable or disable EcoPower Feature in your panel. EcoPower can increase the battery life of your system by reducing the display brightness when appropriate.</p> <p>By default, Enable EcoPower option is enabled.</p>
Full Screen Logo	<p>Enable or disable full screen logo.</p> <p>By default, the option is not enabled.</p>

Table 9. System setup options—Connection menu

Connection	
Wireless Device Enable	
WLAN	<p>Enable or disable the internal WLAN device.</p> <p>By default, the option enabled.</p>
Bluetooth	<p>Enable or disable the internal Bluetooth device</p> <p>By default, the option enabled.</p>
Enable UEFI Network Stack	<p>Enable or disable UEFI Network Stack and controls the on-board LAN Controller.</p> <p>By default, the Enable UEFI Network Stack option is enabled.</p>
HTTPs Boot Feature	
HTTPs Boot	<p>Enable or disable the HTTPs Boot feature.</p> <p>By default, the HTTPs Boot option is disabled.</p>

Table 10. System setup options—Power menu

Power	
Battery configuration	<p>Enables the system to run on battery during peak power usage hours. Use the table Custom Charge Start and Custom Charge Stop, to prevent AC power usage between certain times of each day.</p> <p>By default, the Adaptive option is enabled.</p>
Advanced Configuration	
Enable Advanced Battery Charge Configuration	<p>Enable or disable the advanced battery charge configuration.</p> <p>By default, the Enable Advanced Battery Charge Configuration option is disabled.</p>
Peak Shift	
Enable Peak Shift	<p>Enables the system to run on battery during peak power usage hours.</p> <p>By default, the Enable Peak Shift option is disabled.</p>
Thermal Management	
	<p>Enables to cool the fan and processor heat management to adjust the system performance, noise, and temperature.</p> <p>By default, the Optimized option is enabled.</p>
USB Wake Support	
Enable USB Wake Support	<p>When enabled, the USB devices like a mouse or keyboard can be used to wake the system from Standby, Hibernate, and Power Off.</p> <p> NOTE: This feature requires Deep Sleep Control to be disabled.</p>

Table 10. System setup options—Power menu (continued)

Power	
	<p>NOTE: This feature is only functional when the AC power adapter is connected. If the AC power adapter is removed before Standby, the BIOS will remove power from all of the USB ports to conserve battery power.</p> <p>By default, the Enable USB Wake Support option is disabled.</p>
Wake on Dell USB-C Dock	<p>When enabled, connecting a Dell USB-C Dock will wake the system from Standby, Hibernate, and Power Off.</p> <p>By default, the Wake on Dell USB-C Dock option is enabled.</p>
Block Sleep	<p>Enables to block entering sleep (S3) mode in the operating system.</p> <p>By default, the Block Sleep option is disabled.</p>
Lid Switch	
Enabled Lid Switch	<p>Enable or disable the lid switch.</p> <p>By default, the Enable Lid Switch option is enabled.</p>
Power On Lid Open	<p>When enabled, allows the system to power up from the off state whenever the lid is opened.</p> <p>By default, the Power On Lid Open option is enabled.</p>
Intel Speed Shift Technology	<p>Enable or disable the Intel speed shift technology support.</p> <p>By default, the Intel Speed Shift Technology option is enabled.</p>

Table 11. System setup options—Security menu

Security	
TPM 2.0 Security	
TPM 2.0 Security On	<p>Allows you to enable or disable TPM visibility to operating system.</p> <p>By default, the TPM 2.0 Security On option is enabled.</p>
Attestation Enable	<p>Enables to control whether the Trusted Platform Module (TPM) Endorsement Hierarchy is available to the operating system.</p> <p>By default, the Attestation Enable option is enabled.</p>
Key Storage Enable	<p>Enables to control whether the Trusted Platform Module (TPM) Storage Hierarchy is available to the operating system.</p> <p>By default, the Key Storage Enable option is enabled.</p>
SHA-256	<p>When enabled, the BIOS and TPM will use the SHA-256 hash algorithm to extend measurements into the TPM PCRs during BIOS boot.</p> <p>By default, the SHA-256 option is enabled.</p>
Clear	<p>Enables to clear the TPM owner information and returns the TPM to the default state.</p> <p>By default, the Clear option is disabled.</p>
PPI Bypass for Clear Commands	<p>Controls the TPM Physical Presence Interface (PPI).</p> <p>By default, the PPI ByPass for clear Commands option is disabled.</p>
SMM Security Mitigation	<p>Enable or disable additional UEFI SMM Security Mitigation protections.</p> <p>By default, the option is enabled.</p>
Data Wipe on Next Boot	
Start Data Wipe	<p>Enable or disable the data wipe on next boot.</p>

Table 11. System setup options—Security menu (continued)

Security	
Absolute	<p>By default, the Start Data Wipe option is disabled.</p> <p>Enable or disable or permanently disable the BIOS module interface of the optional Absolute Persistence Module service from Absolute software.</p> <p>By default, the option is enabled.</p> <p>⚠ WARNING: The 'Permanently Disabled' option can only be selected once. When 'Permanently Disabled' is selected, Absolute Persistence cannot be re-enabled. No further changes to the Enable/Disable states are allowed.</p> <p>i NOTE: The Enable/Disable options will be unavailable while Computrace is in the activated state.</p>
UEFI Boot Path Security	<p>Controls whether the system will prompt the user to enter the admin password (if set) when booting to a UEFI boot path device from the F12 boot menu.</p> <p>By default, the Always Except Internal HDD option is enabled.</p>

Table 12. System setup options—Passwords menu

Passwords	
Admin Password	Set, change, or delete the administrator password.
System Password	Set, change, or delete the system password.
NVMe SSD0	Set, change, or delete the NVMe SSD0 password.
Password Configuration	
Upper Case Letter	<p>Reinforces password must have at least one upper case letter.</p> <p>By default, the option is disabled.</p>
Lower Case Letter	<p>Reinforces password must have at least one lower case letter.</p> <p>By default, the option is disabled.</p>
Digit	<p>Reinforces password must have at least one digit number.</p> <p>By default, the option is disabled.</p>
Special Character	<p>Reinforces password must have at least one special character.</p> <p>By default, the option is disabled.</p>
Minimum Characters	Set the minimum characters allowed for password.
Password Bypass	<p>When enabled, this always prompts for system and internal hard drive passwords when powered on from the off state.</p> <p>By default, the Disabled option is selected.</p>
Password Changes	
Enable Non-Admin Password Changes	<p>Enable or disable to change system and hard drive password without the need for admin password.</p> <p>By default, the option is enabled.</p>
Admin Setup Lockout	
Enable Admin Setup Lockout	<p>Enables administrators control over how their users can or cannot access BIOS setup.</p> <p>By default, the option is disabled.</p>
Master Password Lockout	

Table 12. System setup options—Passwords menu (continued)

Passwords	
Enable Master Password Lockout	When enabled, this disables the master password support. By default, the option is disabled.
Allow Non-Admin PSID Revert	
Enable Allow Non-Admin PSID Revert	Controls access to the Physical Security ID (PSID) revert of NVMe hard-drives from the Dell Security Manager prompt. By default, the option is disabled.

Table 13. System setup options—Update, Recovery menu

Update, Recovery	
UEFI Capsule Firmware Updates	Enable or disable BIOS updates through UEFI capsule update packages. i NOTE: Disabling this option will block BIOS updates from services such as Microsoft Windows Update and Linux Vendor Firmware Service (LVFS). By default, the option is enabled.
BIOS Recovery from Hard Drive	Enables the user to recover from certain corrupted BIOS conditions from a recovery file on the user primary hard drive or an external USB key. By default, the option is enabled. i NOTE: BIOS Recovery from Hard Drive is not available for self-encrypting drives (SED).
BIOS Downgrade	
Allow BIOS Downgrade	This field controls the flashing of the system firmware to previous revisions. By default, the option is enabled.
SupportAssist OS Recovery	Enable or disable the boot flow for SupportAssist OS Recovery tool in the event of certain system errors. By default, the option is enabled.
BIOSConnect	Enable or disable cloud Service operating system recovery if the main operating system fails to boot with the number of failures equal to or greater than the value specified by the Auto operating system Recovery Threshold setup option and local Service operating system does not boot or is not installed. By default, the option is enabled.
Dell Auto operating system Recovery Threshold	Controls the automatic boot flow for SupportAssist System Resolution Console and for Dell operating system Recovery Tool. By default, the threshold value is set to 2.

Table 14. System setup options—System Management menu

System Management	
Service Tag	Displays the Service Tag of the system.
Asset Tag	Create a system Asset Tag.
AC Behavior	
Wake on AC	Enable or disable the wake on AC option. By default, the option is disabled.
Auto on Time	Enable to set the system to turn on automatically every day or on a preselected date and time. This option can be configured only if the Auto On Time is set to Everyday, Weekdays, or Selected Days.

Table 14. System setup options—System Management menu (continued)

System Management	
	By default, the option is disabled.

Table 15. System setup options—Keyboard menu

Keyboard	
Numlock Enable	Allows you to enable or disable the Numlock function when the system boots. By default, the option Fn Lock Options is enabled.
Fn Lock Options	By default, the Fn lock option is enabled.
Lock Mode	By default, the Lock Mode Secondary option is enabled. With this option, the F1-F2 keys scan the code for their secondary functions.

Table 16. System setup options—Pre-boot Behavior menu

Pre-boot Behavior	
Adapter Warnings	
Enable Adapter Warnings	Enable or disable the warning messages during boot when the adapters with less power capacity are detected. By default, the option is enabled.
Warning and Errors	
	Enable or disable the action to be done when a warning or error is encountered. By default, the Prompt on Warnings and Errors option is enabled.
USB-C Warnings	
Enable Dock Warning Messages	By default, the option is enabled.
Fastboot	
	Allows you to configure the speed of the UEFI boot process. By default, the Minimal option is enabled.
Extend BIOS POST Time	
	Set the BIOS POST load time. By default, the 0 seconds option is enabled.

Table 17. System setup options—Virtualization menu

Virtualization	
Intel Virtualization Technology	
Enable Intel Virtualization Technology (VT)	When enabled, the system will be able to run a Virtual Machine Monitor (VMM). By default, the option is enabled.
VT for Direct I/O	
	When enabled, the system will be able to perform Virtualization Technology for Direct I/O (VT-d). By default, the option is enabled.
Intel Trusted Execution Technology (TXT)	
Enable Intel Trusted Execution Technology (TXT)	Specifies whether a measured Virtual Machine Monitor (MVMM) can use the additional hardware capabilities that are provided by Intel Trusted Execution Technology. The following must be enabled in order to enable Intel TXT. <ul style="list-style-type: none"> • Trusted Platform Module (TPM) • Intel Hyper-Threading • All CPU cores (Multi-Core Support) • Intel Virtualization Technology

Table 17. System setup options—Virtualization menu (continued)

Virtualization	
	<ul style="list-style-type: none"> • Intel VT for Direct I/O By default, the option is disabled.

Table 18. System setup options—Performance menu

Performance	
Multi Core Support	
Active Cores	Enables to change the number of CPU cores available to the operating system. By default, the All Cores option is enabled.
Intel SpeedStep	
Enable Intel SpeedStep Technology	Enables the system to dynamically adjust processor voltage and core frequency, decreasing average power consumption and heat production. By default, the option is enabled.
C-States Control	
Enable C-State Control	Enable the ability of the CPU to enter and exit low power state. When disabled, it disabled all C-states. When enabled, it enabled all C-states that the chipset or platform allows. By default, the option is enabled.
Intel Turbo Boost Technology	
Enable Intel Turbo Boost Technology	Enable or disable the Intel TurboBoost mode of the processor. By default, the option is enabled.
Intel Hyper-Threading Technology	
Enable Intel Hyper-Threading Technology	Enable or disable Hyper-Threading in the processor. By default, the option is enabled.
Dynamic Tuning:Machine Learning	
Enable Dynamic Tuning:Machine Learning	Enables the operating system capability to enhance dynamic power tuning capabilities based on detected workloads. By default, the option is disabled.

Table 19. System setup options—System Logs menu

System Logs	
BIOS Event Log	
Clear Bios Event Log	Displays BIOS events. By default, the Keep Log option is enabled.
Thermal Event Log	
Clear Thermal Event Log	Displays Thermal events. By default, the Keep Log option is enabled.
Power Event Log	
Clear Power Event Log	Displays power events. By default, the Keep Log option is enabled.
License Information	Displays the license information of the system.

Updating the BIOS

Updating the BIOS in Windows

About this task

 **CAUTION:** If BitLocker is not suspended before updating the BIOS, the next time you reboot the system it will not recognize the BitLocker key. You will then be prompted to enter the recovery key to progress and the system will ask for this on each reboot. If the recovery key is not known this can result in data loss or an unnecessary operating system re-install. For more information on this subject, see Knowledge Article: <https://www.dell.com/support/article/sln153694>

Steps

1. Go to www.dell.com/support.
2. Click **Product support**. In the **Search support** box, enter the Service Tag of your computer, and then click **Search**.
 **NOTE:** If you do not have the Service Tag, use the SupportAssist feature to automatically identify your computer. You can also use the product ID or manually browse for your computer model.
3. Click **Drivers & Downloads**. Expand **Find drivers**.
4. Select the operating system installed on your computer.
5. In the **Category** drop-down list, select **BIOS**.
6. Select the latest version of BIOS, and click **Download** to download the BIOS file for your computer.
7. After the download is complete, browse the folder where you saved the BIOS update file.
8. Double-click the BIOS update file icon and follow the on-screen instructions.
For more information, see knowledge base article [000124211](https://www.dell.com/support/article/000124211) at www.dell.com/support.

Updating the BIOS in Linux and Ubuntu

To update the system BIOS on a computer that is installed with Linux or Ubuntu, see the knowledge base article [000131486](https://www.dell.com/support/article/000131486) at www.dell.com/support.

Updating the BIOS using the USB drive in Windows

About this task

 **CAUTION:** If BitLocker is not suspended before updating the BIOS, the next time you reboot the system it will not recognize the BitLocker key. You will then be prompted to enter the recovery key to progress and the system will ask for this on each reboot. If the recovery key is not known this can result in data loss or an unnecessary operating system re-install. For more information on this subject, see Knowledge Article: <https://www.dell.com/support/article/sln153694>

Steps

1. Follow the procedure from step 1 to step 6 in [Updating the BIOS in Windows](#) to download the latest BIOS setup program file.
2. Create a bootable USB drive. For more information, see the knowledge base article [000145519](https://www.dell.com/support/article/000145519) at www.dell.com/support.
3. Copy the BIOS setup program file to the bootable USB drive.
4. Connect the bootable USB drive to the computer that needs the BIOS update.
5. Restart the computer and press **F12**.
6. Select the USB drive from the **One Time Boot Menu**.
7. Type the BIOS setup program filename and press **Enter**.
The **BIOS Update Utility** appears.
8. Follow the on-screen instructions to complete the BIOS update.

Updating the BIOS from the F12 One-Time boot menu

Update your computer BIOS using the BIOS update.exe file that is copied to a FAT32 USB drive and booting from the F12 One-Time boot menu.

About this task

CAUTION: If BitLocker is not suspended before updating the BIOS, the next time you reboot the system it will not recognize the BitLocker key. You will then be prompted to enter the recovery key to progress and the system will ask for this on each reboot. If the recovery key is not known this can result in data loss or an unnecessary operating system re-install. For more information on this subject, see Knowledge Article: <https://www.dell.com/support/article/sln153694>

BIOS Update

You can run the BIOS update file from Windows using a bootable USB drive or you can also update the BIOS from the F12 One-Time boot menu on the computer.

Most of the Dell computers built after 2012 have this capability, and you can confirm by booting your computer to the F12 One-Time Boot Menu to see if BIOS FLASH UPDATE is listed as a boot option for your computer. If the option is listed, then the BIOS supports this BIOS update option.

NOTE: Only computers with BIOS Flash Update option in the F12 One-Time boot menu can use this function.

Updating from the One-Time boot menu

To update your BIOS from the F12 One-Time boot menu, you need the following:

- USB drive formatted to the FAT32 file system (key does not have to be bootable)
- BIOS executable file that you downloaded from the Dell Support website and copied to the root of the USB drive
- AC power adapter that is connected to the computer
- Functional computer battery to flash the BIOS

Perform the following steps to perform the BIOS update flash process from the F12 menu:

CAUTION: Do not turn off the computer during the BIOS update process. The computer may not boot if you turn off your computer.

Steps

1. From a turn off state, insert the USB drive where you copied the flash into a USB port of the computer.
2. Turn on the computer and press F12 to access the One-Time Boot Menu, select BIOS Update using the mouse or arrow keys then press Enter.
The flash BIOS menu is displayed.
3. Click **Flash from file**.
4. Select external USB device.
5. Select the file and double-click the flash target file, and then click **Submit**.
6. Click **Update BIOS**. The computer restarts to flash the BIOS.
7. The computer will restart after the BIOS update is completed.

System and setup password

Table 20. System and setup password

Password type	Description
System password	Password that you must enter to log in to your system.
Setup password	Password that you must enter to access and make changes to the BIOS settings of your computer.

You can create a system password and a setup password to secure your computer.

 **CAUTION:** The password features provide a basic level of security for the data on your computer.

 **CAUTION:** Anyone can access the data that is stored on your computer if it is not locked and left unattended.

 **NOTE:** System and setup password feature is disabled.

Assigning a system setup password

Prerequisites

You can assign a new **System or Admin Password** only when the status is in **Not Set**.

About this task

To enter the system setup, press F12 immediately after a power-on or reboot.

Steps

1. In the **System BIOS** or **System Setup** screen, select **Security** and press Enter.
The **Security** screen is displayed.
2. Select **System/Admin Password** and create a password in the **Enter the new password** field.
Use the following guidelines to assign the system password:
 - A password can have up to 32 characters.
 - At least one special character: ! " # \$ % & ' () * + , - . / : ; < = > ? @ [\] ^ _ ` { | }
 - Numbers 0 through 9.
 - Upper case letters from A to Z.
 - Lower case letters from a to z.
3. Type the system password that you entered earlier in the **Confirm new password** field and click **OK**.
4. Press Esc and save the changes as prompted by the pop-up message.
5. Press Y to save the changes.
The computer restarts.

Deleting or changing an existing system setup password

Prerequisites

Ensure that the **Password Status** is Unlocked (in the System Setup) before attempting to delete or change the existing System and/or Setup password. You cannot delete or change an existing System or Setup password, if the **Password Status** is Locked.

About this task

To enter the System Setup, press F12 immediately after a power-on or reboot.

Steps

1. In the **System BIOS** or **System Setup** screen, select **System Security** and press Enter.
The **System Security** screen is displayed.
2. In the **System Security** screen, verify that **Password Status** is **Unlocked**.
3. Select **System Password**, update, or delete the existing system password, and press Enter or Tab.
4. Select **Setup Password**, update, or delete the existing setup password, and press Enter or Tab.
 **NOTE:** If you change the System and/or Setup password, reenter the new password when prompted. If you delete the System and/or Setup password, confirm the deletion when prompted.
5. Press Esc and a message prompts you to save the changes.
6. Press Y to save the changes and exit from System Setup.
The computer restarts.

Clearing CMOS settings

About this task

 **CAUTION:** Clearing CMOS settings will reset the BIOS settings on your computer.

Steps

1. Remove the [side cover](#).
2. Remove the [riser card](#).
3. Remove the [coin-cell battery](#).
4. Wait for one minute.
5. Replace the [coin-cell battery](#).
6. Replace the [riser card](#).
7. Replace the [side cover](#).

Clearing BIOS (System Setup) and System passwords

About this task

To clear the system or BIOS passwords, contact Dell technical support as described at www.dell.com/contactdell.

 **NOTE:** For information on how to reset Windows or application passwords, refer to the documentation accompanying Windows or your application.

Troubleshooting

Dell SupportAssist Pre-boot System Performance Check diagnostics

About this task

SupportAssist diagnostics (also known as system diagnostics) performs a complete check of your hardware. The Dell SupportAssist Pre-boot System Performance Check diagnostics is embedded with the BIOS and is launched by the BIOS internally. The embedded system diagnostics provides a set of options for particular devices or device groups allowing you to:

- Run tests automatically or in an interactive mode
- Repeat tests
- Display or save test results
- Run thorough tests to introduce additional test options to provide extra information about the failed device(s)
- View status messages that inform you if tests are completed successfully
- View error messages that inform you of problems encountered during testing

NOTE: Some tests for specific devices require user interaction. Always ensure that you are present at the computer terminal when the diagnostic tests are performed.

For more information, see <https://www.dell.com/support/kbdoc/000180971>.

Running the SupportAssist Pre-Boot System Performance Check

Steps

1. Turn on your computer.
2. As the computer boots, press the F12 key as the Dell logo appears.
3. On the boot menu screen, select the **Diagnostics** option.
4. Click the arrow at the bottom left corner.
Diagnostics front page is displayed.
5. Click the arrow in the lower-right corner to go to the page listing.
The items detected are listed.
6. To run a diagnostic test on a specific device, press Esc and click **Yes** to stop the diagnostic test.
7. Select the device from the left pane and click **Run Tests**.
8. If there are any issues, error codes are displayed.
Note the error code and validation number and contact Dell.

System-diagnostic lights

This section lists the system-diagnostic lights of your Precision 3260 Compact.

Table 21. System-diagnostic lights

Blinking pattern		Problem description	Suggested resolution
Amber	White		
1	2	Unrecoverable SPI Flash Failure	Replace the system board.

Table 21. System-diagnostic lights (continued)

Blinking pattern		Problem description	Suggested resolution
Amber	White		
2	1	CPU failure	<ul style="list-style-type: none"> • Run the Dell Support Assist/Dell Diagnostics tool. • If problem persists, replace the system board.
2	2	System board failure (included BIOS corruption or ROM error)	<ul style="list-style-type: none"> • Flash latest BIOS version • If problem persists, replace the system board.
2	3	No memory/RAM detected	<ul style="list-style-type: none"> • Confirm that the memory module is installed properly. • If problem persists, replace the memory module.
2	4	Memory/RAM failure	<ul style="list-style-type: none"> • Reset and swap memory modules among the slots. • If problem persists, replace the memory module.
2	5	Invalid memory installed	<ul style="list-style-type: none"> • Reset and swap memory modules among the slots. • If problem persists, replace the memory module.
2	6	System board/Chipset Error	Replace the system board.
3	1	CMOS battery failure	<ul style="list-style-type: none"> • Reset the main battery connection. • If problem persists, replace the main battery.
3	2	PCI or Video card/chip failure	Replace the system board.
3	3	BIOS Recovery image not found	<ul style="list-style-type: none"> • Flash latest BIOS version • If problem persists, replace the system board.
3	4	BIOS Recovery image found but invalid	<ul style="list-style-type: none"> • Flash latest BIOS version • If problem persists, replace the system board.
3	5	Power rail failure	<ul style="list-style-type: none"> • EC ran into power sequencing failure. • If problem persists, replace the system board.
3	6	Flash corruption detected by SBIOS.	<ul style="list-style-type: none"> • Press power button for over 25 seconds to do RTC reset. If problem persists, replace the system board. • Disconnect all power source (AC, battery, coin cell) and drain flea power by pressing and holding down power button 3~5

Table 21. System-diagnostic lights (continued)

Blinking pattern		Problem description	Suggested resolution
Amber	White		
			<p>seconds to ensure all power are drained.</p> <ul style="list-style-type: none"> • Run "BIOS recovery from USB", and the instructions are in the website Dell support. • If problem persists, replace the system board.
3	7	Timeout waiting on ME to reply to HECI message.	<ul style="list-style-type: none"> • Timeout waiting on ME to reply to HECI message • If problem persists, replace the system board.
4	2	CPU Power Cable Connection Issue	

Recovering the operating system

When your computer is unable to boot to the operating system even after repeated attempts, it automatically starts Dell SupportAssist OS Recovery.

Dell SupportAssist OS Recovery is a standalone tool that is preinstalled in all Dell computers installed with Windows operating system. It consists of tools to diagnose and troubleshoot issues that may occur before your computer boots to the operating system. It enables you to diagnose hardware issues, repair your computer, back up your files, or restore your computer to its factory state.

You can also download it from the Dell Support website to troubleshoot and fix your computer when it fails to boot into their primary operating system due to software or hardware failures.

For more information about the Dell SupportAssist OS Recovery, see *Dell SupportAssist OS Recovery User's Guide* at www.dell.com/serviceabilitytools. Click **SupportAssist** and then, click **SupportAssist OS Recovery**.

Real Time Clock—RTC reset

The Real Time Clock (RTC) reset function allows you or the service technician to recover the recently launched model Dell Latitude and Precision systems from **No POST/No Boot/No Power** situations. You can initiate the RTC reset on the system from a power-off state only if it is connected to AC power. Press and hold the power button for 25 seconds. The system RTC reset occurs after you release the power button.

i **NOTE:** If AC power is disconnected from the system during the process or the power button is held longer than 40 seconds, the RTC reset process gets aborted.

The RTC reset will reset the BIOS to Defaults, un-provision Intel vPro and reset the system date and time. The following items are unaffected by the RTC reset:

- Service Tag
- Asset Tag
- Ownership Tag
- Admin Password
- System Password
- HDD Password
- Key Databases
- System Logs

i **NOTE:** The IT administrator's vPro account and password on the system will be un-provisioned. The system needs to go through the setup and configuration process again to reconnect it to the vPro server.

The below items may or may not reset based on your custom BIOS setting selections:

- Boot List
- Enable Legacy Option ROMs
- Secure Boot Enable
- Allow BIOS Downgrade

Backup media and recovery options

It is recommended to create a recovery drive to troubleshoot and fix problems that may occur with Windows. Dell proposes multiple options for recovering Windows operating system on your Dell PC. For more information, see [Dell Windows Backup Media and Recovery Options](#).

WiFi power cycle

About this task

If your computer is unable to access the internet due to WiFi connectivity issues a WiFi power cycle procedure may be performed. The following procedure provides the instructions on how to conduct a WiFi power cycle:

 **NOTE:** Some ISPs (Internet Service Providers) provide a modem/router combo device.

Steps

1. Turn off your computer.
2. Turn off the modem.
3. Turn off the wireless router.
4. Wait for 30 seconds.
5. Turn on the wireless router.
6. Turn on the modem.
7. Turn on your computer.

System limitations

This section contains information about some limitations of this computer.

- [Modern standby support limitation](#)
- [Intel System Agent Enhanced Speed Step \(SAGV\) always disabled](#)
- [TPM setting through SMMM](#)

Modern standby support limitation

- Computers with 2.5-inch hard drives take longer to enter Modern Standby for the first time. Computer will enter Modern Standby normally from the second time onwards.
- Computers with Add-in cards and Graphic cards which are not Dell factory installed may not enter Modern Standby as these cards may not be compliant with Modern Standby.

Table 22. Computer behavior with hard drives and add-in cards which do not support modern standby

System behavior	Screen	dGfx fan	Hard drive LED	PWR LED	Processor fan
MODS "Should be"	Off	Off	Off	Off	Off
MODS first entry on SATA hard drive	Off	Off/On (Up to dGfx)	On	Off	On

Table 22. Computer behavior with hard drives and add-in cards which do not support modern standby (continued)

System behavior	Screen	dGfx fan	Hard drive LED	PWR LED	Processor fan
MODS "Should be"	Off	Off	Off	Off	Off
MODS normal after second entry on SATA hard drive	Off	Off	Off	Off	Off

Intel System Agent Enhanced Speed Step (SAGV) always disabled

For Precision 3260 Compact, the SAGV option is disabled by default. If enabled, your computer will incur additional boot time when memory is added or swapped.

TPM setting through SMMM

When the system board is replaced, by default the TPM is enabled and this is applicable for most of the computers in the rest of the world. Select the **Enable Firmware/Integrated TPM - For Regional Restrictions** option, this option permanently disables the Discrete Hardware TPM and applicable for China region.

Service Menu

AMT Selection

(1) AMT_DASH_VPRO_or_SBA

(3) MANAGEABILITY ENGINE (ME) DISABLED

Service Tag (required)

Asset Tag (optional)

BlueTooth

Enabled

TPM Configuration (For Regional Restrictions)

Enable Discrete TPM- Most Common



Enable Firmware/Integrated TPM - For Regional Restrictions

Getting help and contacting Dell

Self-help resources

You can get information and help on Dell products and services using these self-help resources:

Table 23. Self-help resources

Self-help resources	Resource location
Information about Dell products and services	www.dell.com
My Dell app	
Tips	
Contact Support	In Windows search, type <code>Contact Support</code> , and press Enter.
Online help for operating system	www.dell.com/support/windows www.dell.com/support/linux
Access top solutions, diagnostics, drivers and downloads, and learn more about your computer through videos, manuals and documents.	Your Dell computer is uniquely identified by a Service Tag or Express Service Code. To view relevant support resources for your Dell computer, enter the Service Tag or Express Service Code at www.dell.com/support . For more information on how to find the Service Tag for your computer, see Locate the Service Tag on your computer .
Dell knowledge base articles for a variety of computer concerns	<ol style="list-style-type: none"> 1. Go to www.dell.com/support. 2. On the menu bar at the top of the Support page, select Support > Knowledge Base. 3. In the Search field on the Knowledge Base page, type the keyword, topic, or model number, and then click or tap the search icon to view the related articles.

Contacting Dell

To contact Dell for sales, technical support, or customer service issues, see www.dell.com/contactdell.

 **NOTE:** Availability varies by country/region and product, and some services may not be available in your country/region.

 **NOTE:** If you do not have an active Internet connection, you can find contact information about your purchase invoice, packing slip, bill, or Dell product catalog.