

# Color Video Camera

VISCA Command List  
CGI Command List  
Software Version 1.0

SRG-A40/A12

# Table of Contents

<b>Overview .....</b>	<b>3</b>
About This Document .....	3
<b>VISCA .....</b>	<b>3</b>
Overview of VISCA .....	3
VISCA Communication Specifications .....	4
VISCA Device Setting Command .....	6
VISCA Command/ACK Protocol .....	7
VISCA Camera-Issued Messages .....	8
<b>VISCA over IP .....</b>	<b>9</b>
Overview of VISCA over IP .....	9
Communication Method of VISCA over IP .....	10
<b>VISCA Command List .....</b>	<b>14</b>
Command List .....	14
Inquiry Command List .....	20
Block Inquiry Command .....	24
<b>Camera IP Setting Command .....</b>	<b>29</b>
<b>CGI .....</b>	<b>30</b>
Advance Preparation .....	30
IP Address Settings by RM-IP Setup Tool .....	30
Setting the Initial Password .....	30
Changing the Setting of Referer Check .....	31
About Authentication .....	31
<b>Setting/Inquiring by CGI Commands .....</b>	<b>31</b>
Setting by Commands .....	31
Inquiring by Commands .....	31
<b>CGI Command List .....</b>	<b>33</b>
<b>Supported Codecs .....</b>	<b>73</b>
<b>RTSP Request URL .....</b>	<b>73</b>
<b>RTSP Methods .....</b>	<b>74</b>
Supported Methods .....	74
Typical Sequence of RTSP Communication .....	75
<b>Stream Acquisition .....</b>	<b>76</b>
Video Stream Acquisition .....	77
<b>RTP/RTCP .....</b>	<b>86</b>
RTP Header Fields .....	86
SR: Sender Report RTCP Packet .....	87
<b>Userdata Information in Video</b>	
<b>Bitstream .....</b>	<b>88</b>
Userdata Information Under H.264 Video Codec .....	88
Userdata Information Under H.265 Video Codec .....	89
<b>VISCA/CGI Command Setting Values .....</b>	<b>90</b>

Use of control software based upon this command list may cause malfunction or damage to hardware and software. We are not liable for any such damage.

# Overview

## About This Document

This document describes the specifications of the VISCA command, CGI command, and RTSP streaming of Sony color video camera SRG-A40, SRG-A12. In this document, the product is referred to as "the cameras."

# VISCA

VISCA<sup>1)</sup> is a protocol developed by Sony for controlling a consumer's camcorder.

## Overview of VISCA

In VISCA, the side outputting commands, such as a computer, is called the controller, while the side receiving the commands, such as a SRG-A40/A12<sup>2)</sup>, is called the peripheral device. In VISCA, up to seven peripheral devices including this camera can be connected to a single controller using communication conforming to the RS-422 standard. The parameters of RS-422 are as follows.

- Communication speed: 9600 bps/38400 bps
- Data bits : 8
- Start bit : 1
- Stop bit : 1
- Non parity

Flow control using XON/XOFF and RTS/CTS, etc., is not supported.

Peripheral devices are connected in a daisy chain. As shown in Fig. 1, the actual internal connection is a one-direction ring, so that messages return to the controller via the peripheral devices. The devices on the network are assigned addresses. The address of the controller is fixed at 0. The peripheral devices are assigned to the addresses, 1, 2, 3... in the connected order, starting from the one connected nearest to the controller. These addresses are set when the controller sends address commands during initialization of the network.

### Note

Each VISCA equipment has VISCA IN and VISCA OUT connectors. Set the DTR input (the S output of the controller) of VISCA IN to H when controlling VISCA equipment from the controller.

Fig. 1 VISCA network configuration

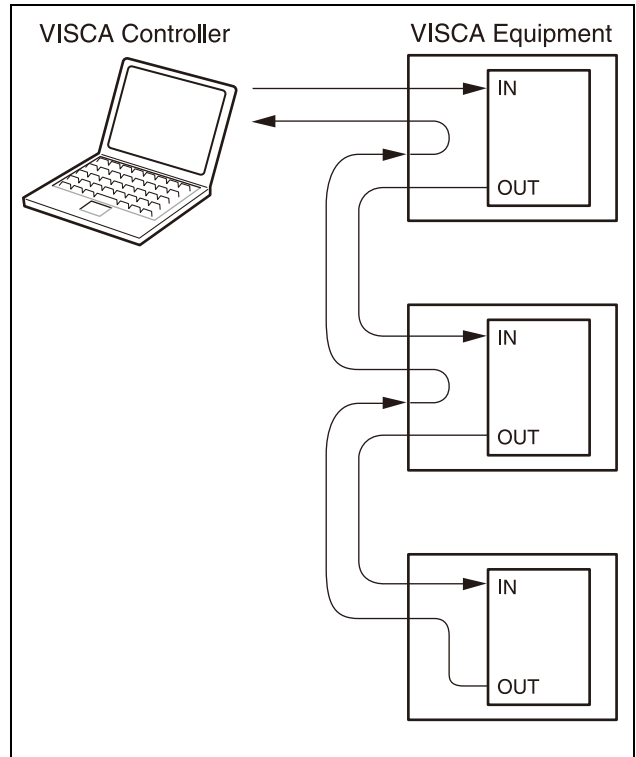

1) "VISCA" is a trademark of Sony Corporation.

2) The product name of this camera, "Color video camera SRG-A40/A12" is referred to as "the camera" in this document.

# VISCA Communication Specifications

## VISCA packet structure

The basic unit of VISCA communication is called a packet (Fig. 2). The first byte of the packet is called the header and the packet comprises the sender's and receiver's addresses. For example, the header of the packet sent to the camera (address 1) from the controller (address 0) is 81H in hexadecimal. Packet sent to the camera (address 2) is 82H.

In the command list, as the header is 8X, input the address of the camera to X. The header of the reply packet from the camera assigned to address 1 is 90H. The packet from the camera assigned to address 2 is A0H.

Some of the setting commands can be sent to all devices at one time (broadcast) \*.

In the case of broadcast, the header should be 88H in hexadecimal.

When the terminator is FFH, it signifies the end of the packet.

\* The broadcast function is not available for VISCA over IP.

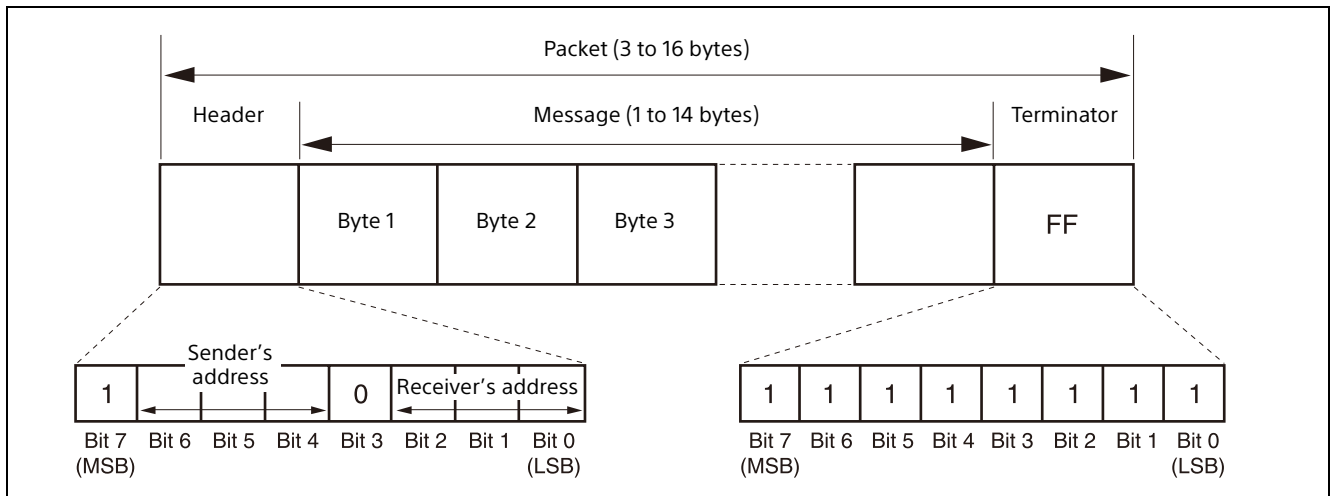

Fig. 2 Packet structure

### Note

Fig. 2 shows the packet structure, while Fig. 3 shows the actual waveform. Data flow will take place with the LSB first.

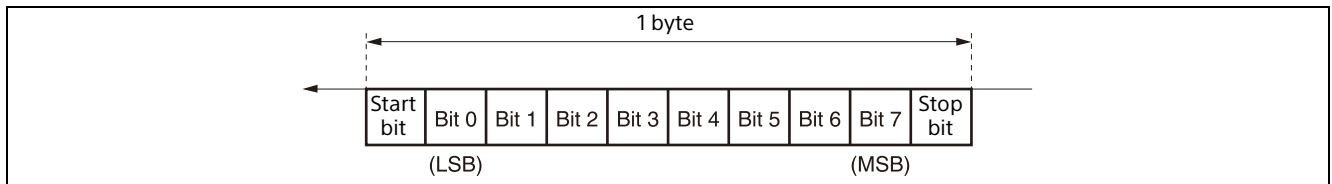

Fig. 3 Actual waveform for 1 byte

## Timing Chart

As VISCA command processing can only be carried out a maximum of one time in a Vertical (V) cycle, it takes maximum 4V-cycle time for an ACK/Completion to be returned.

If the Command and ACK/Completion communication time is shorter than 1V-cycle time, a command can be received at every 1V cycle.

From this point, if two or more commands are to be sent successively, wait for a reply command (an ACK or error message for a general command, and an inquiry packet for an inquiry command) of the previous command to be received before sending the next command.

1V= 16.7 msec (1080/59.94p, 1080/59.94i, 720/59.94p),  
 20 msec (1080/50p, 1080/50i, 720/50p),  
 33.4 msec (2160/29.97p),  
 40 msec (2160/25p),  
 41.7 msec (1080/23.98p, 2160/23.98p)

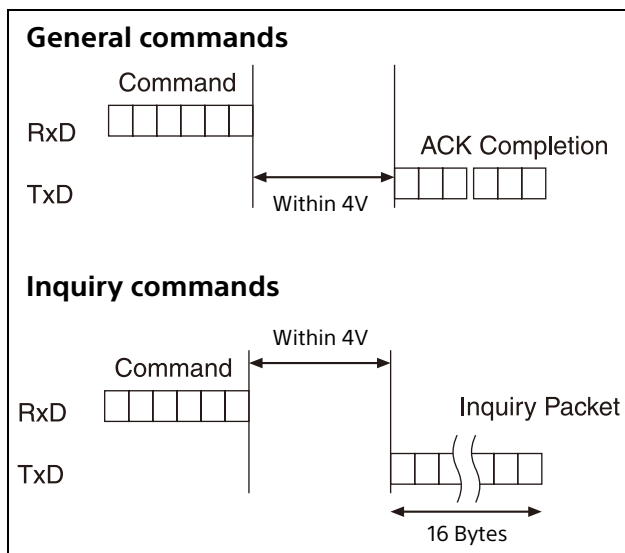

## Command and inquiry

### • Command

Sends operational commands to the camera.

### • Inquiry

Used for inquiring about the current state of the camera.

### Command/Inquiry Packet

8X QQ RR ... FF

QQ: Command/Inquiry (01=Command, 09=Inquiry)

RR: Category Code (00=Interface, 04=camera, 06=Pan/Tilter)

X = 1 to 7: Address of the camera (Locked to "X = 1" for VISCA over IP)

For actual values to be sent, see Command Lists or Inquiry Command Lists.

## Responses for commands and inquiries

### • ACK message

Returned by the camera when it receives a command. No ACK message is returned for an inquiry.

### • Completion message

Returned by the camera when execution of commands or inquiries is completed. In the case of inquiry commands, reply data for the inquiry is contained after the 3rd byte of the packet. In the case of commands or inquiries that do not use sockets, the socket number will contain 0.

#### Reply Packet

ACK	Y0 4Z FF
Completion (Commands)	Y0 5Z FF
Completion (Inquiries)	Y0 5Z ... FF

Y = 9 to F: Address of the camera + 8 (Locked to "Y = 9" for VISCA over IP)  
 Z = socket number

### • Error message

When a command or inquiry command could not be executed or failed, an error message is returned instead of a completion message.

#### Error Packet

Message length error	Y0 6Z 01 FF
Syntax Error	Y0 6Z 02 FF
Command buffer full	Y0 6Z 03 FF
Command canceled	Y0 6Z 04 FF
No socket (to be canceled)	Y0 6Z 05 FF
Command not executable	Y0 6Z 41 FF

Y = 9 to F: Address of the camera + 8 (Locked to "Y = 9" for VISCA over IP)  
 Z = socket number

## Socket number

When command messages are sent to the camera, it is normal to send the next command message after receiving the completion message or error message. However, to deal with advanced uses, the camera has two sets of buffers (memories) for commands, so that up to two commands including the commands currently being executed can be received. (There is a wait longer than a 1V cycle between commands.) However, depending on the command, it may be necessary to wait until the first command is completed due to system reasons. When the camera receives commands, it notifies which command buffer was used using the socket number of ACK message. As the completion message or error message also has a socket number, it indicates which command has ended. Even when two command buffers are being used, the camera management command and inquiry messages can be executed.

The ACK message is not returned for these commands and inquiries, and only the completion message of socket number 0 is returned.

### Command execution cancel

To cancel a command which has already been sent, send a Cancel command as the next command. To cancel one of two commands which have been sent, use the cancel message.

	<b>Cancel Packet</b>
Cancel	8X 2Z FF
	X = 1 to 7: Address of the camera (Locked to "X = 1" for VISCA over IP)
	Z = socket number

Error message "Command Canceled" will be returned for this command, but this is not a fault. It indicates that the command has been cancelled.

#### Note

To cancel a command when VISCA PAN-TILT Drive (page 18) is being executed, wait at least 200 msec after executing. Then send a cancel command to ensure that PAN-TILT Drive stops effectively.

To execute a PAN-TILT Drive command again, wait at least 200 msec after the message "Command Canceled" has appeared.

## VISCA Device Setting Command

Before starting control of the camera, make sure to send the Address Set command and IF\_Clear command using the broadcast.

### For VISCA network administration

- **Address Set\***  
Sets an address of a peripheral device. Use when initializing the network, and receiving the following network change message.

\* Not available for VISCA over IP.

- **Network Change\***  
Sent from the peripheral device to the controller when a device is removed from or added to the network. The address must be re-set when this message is received.

\* Not available for VISCA over IP.

	<b>Packet</b>
Address Set	88 30 01 FF
Network Change	Y0 38 FF
	Y = 9 to F: Address of the camera + 8

## VISCA interface command

- **IF\_Clear**  
Clears the command buffer in the camera. When cleared, the operation currently being executed is not guaranteed.

	<b>Command Packet</b>	<b>Reply Packet</b>
IF_Clear	8X 01 00 01 FF	Y0 50 FF
IF_Clear (broadcast)*	88 01 00 01 FF	88 01 00 01 FF
	X = 1 to 7: Address of the camera (Locked to "X = 1" for VISCA over IP)	
	Y = 9 to F: Address of the camera +8 (Locked to "Y = 9" for VISCA over IP)	
	* Not available for VISCA over IP.	

## VISCA interface and inquiry

- **CAM\_VersionInq**  
Returns information on the VISCA interface.

	<b>Inquiry Packet</b>	<b>Reply Packet</b>
CAM_VersionInq	8X 09 00 02 FF	Y0 50 GG GG HH HH JJ JJ KK FF
	X = 1 to 7: Address of the camera (Locked to "X = 1" for VISCA over IP)	
	Y = 9 to F: Address of the camera +8 (Locked to "Y = 9" for VISCA over IP)	
	GGGG = Vender ID	
	0001: Sony	
	HHHH = Model ID	
	0621:SRG-A40	
	0622:SRG-A12	
	JJJJ = ROM revision	
	KK = Maximum socket # (02)	

## VISCA Command/ACK Protocol

Command	Command Message	Reply Message	Comments
General Command	81 01 04 38 02 FF (Example)	90 4z FF (ACK) , 90 5z FF (Completion) (z: Socket No.)	Returns ACK when a command has been accepted, then returns Completion when a command has been executed.
	81 01 04 38 FF (Example)	90 60 02 FF (Syntax Error)	Accepted a command which is not supported or a command lacking parameters.
	81 01 04 38 02 FF (Example)	90 60 03 FF (Command Buffer Full)	Could not accept the command as there are two commands currently being executed.
	81 01 04 08 02 FF (Example)	90 6z 41 FF (Command Not Executable) (z: Socket No.)	Could not execute the command in the current mode.
Inquiry Command	81 09 04 38 FF (Example)	90 50 02 FF (Completion)	Does not return ACK for the Inquiry Command.
	81 09 05 38 FF (Example)	90 60 02 FF (Syntax Error)	Accepted an incompatible command.
Address Set*	88 30 01 FF	88 30 02 FF	Always broadcasted. The device address number plus 1 is returned.
IF_Clear (Broadcast)*	88 01 00 01 FF	88 01 00 01 FF	The same command is returned.
IF_Clear (For x)	8x 01 00 01 FF	y0 50 FF (Completion)	ACK is not returned for this command.
Command Cancel	8x 2p FF	y0 6p 04 FF (Command Canceled)	Returned when the command of the specified socket is cancelled. Completion for the command cancelled is not returned.
		y0 6p 05 FF (No Socket)	Returned when the command of the specified socket has already been completed or when the specified socket number is wrong.

\* Not available for VISCA over IP.

Do not transmit the command (except Address Set, IF\_Clear, Command Cancel and POWER (page 19)) when any menu is displayed on the screen. If displayed, clear the menu first using MENU (page 19) Command, and then proceed.

# VISCA Camera-Issued Messages

## ACK/Completion Messages

Command	Command Message	Comments
ACK	y0 4z FF (z: Socket No.)	Returned when the command is accepted.
Completion	y0 5z FF (z: Socket No.)	Returned when the command has been executed.

y = Device address + 8 (Locked to "y = 9" for VISCA over IP.)

## Error Messages

Command	Command Message	Comments
Syntax Error	y0 60 02 FF	Returned when the command format is different or when a command with illegal command parameters is received.
Command Buffer Full	y0 60 03 FF	Could not accept a command that is received while two commands are currently being executed (two sockets have been used).
Command Canceled	y0 6z 04 FF (z: Socket No.)	Returned when a command which is being executed in a socket specified by the cancel command is cancelled. The completion message for the command is not returned.
No Socket	y0 6z 05 FF (z: Socket No.)	Returned when no command is executed in a socket specified by the cancel command, or when an invalid socket number is specified.
Command Not Executable	y0 6z 41 FF (z: Socket No.)	Returned when a command cannot be executed due to current conditions. For example, when a command for controlling the manual focus is received during the auto focus mode.

y = Device address + 8 (Locked to "y = 9" for VISCA over IP.)

## Network Change Message

Command	Command Message	Comments
Network Change*	y0 38 FF	Issued when power is supplied to the camera.

\* Not available for VISCA over IP.

y = Device address + 8

# VISCA over IP

## Overview of VISCA over IP

With VISCA over IP function, you can control the camera using VISCA on a controller equipped with IP communication capabilities via LAN. You can connect up to 5 controllers simultaneously on the network.

The communication specifications of VISCA over IP are as follows:

- **Interface**  
RJ-45 10BASE-T/100BASE-TX/1000BASE-T (automatically identifying)
- **Internet protocol**  
IPv4
- **Transport protocol**  
UDP
- **IP address**  
Set by the IP setting command (page 29)
- **Port address**  
52381
- **Delivery confirmation/Retransmission control**  
Depends on the application

In these instructions, the device outputting commands, such as a computer, is called the controller, and the device receiving the command, such as an SRG series camera, is called a peripheral device. The controllers and peripheral devices are connected like a one-direction ring on the RS-422 connection, but on the IP communication connection, the controllers and peripheral devices are connected by bus through a LAN.

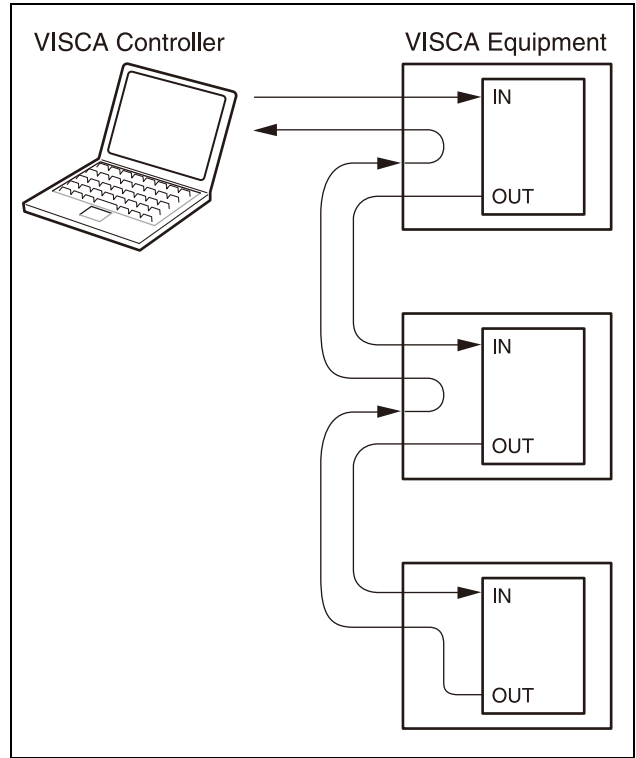

RS422 connection

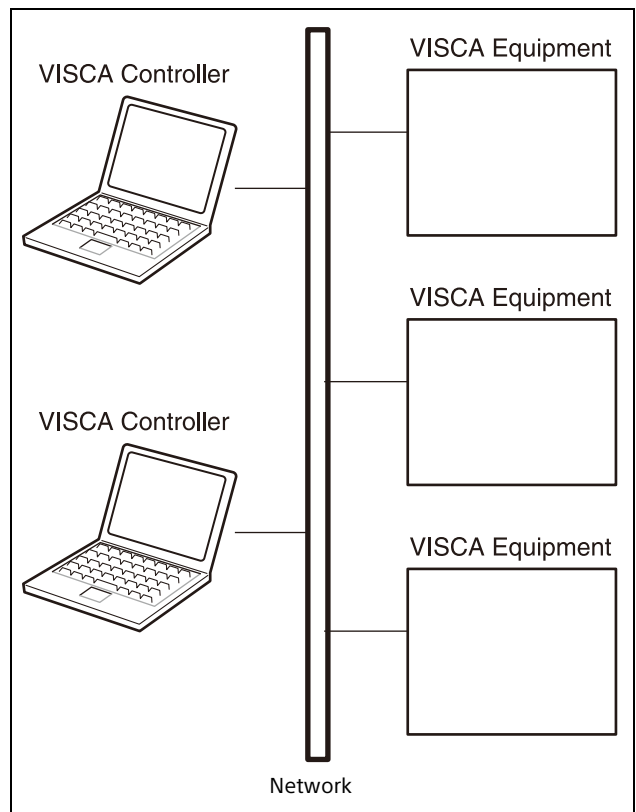

IP communication connection

While the IP communication connection, the address of each device cannot be set in the VISCA message as the controllers and peripheral devices that are connected simultaneously are increased. In this case, addresses of the controllers and peripheral devices that are set in the VISCA message are locked to 0 (for the controller) or 1 (for the peripheral device).

Due to the nature of the IP communication, the use of some VISCA functions are limited. For details, see "Limitation" on page 13.

For how to set an IP address of the camera, see "Camera IP Setting Command" on page 29.

## Communication Method of VISCA over IP

### Communication method

VISCA over IP can process the VISCA communication between the controllers and peripheral devices into the messages that can be identified on the LAN, and sends/receives them. Because of this, VISCA over IP is not concerned about the contents of the communication between the controllers and peripheral devices. However, the VISCA communication sequence is different, depending on the types, as follows.

### VISCA command

This is a command from the controller to the peripheral device.

When the peripheral device receives this command, ACK is returned. After completing command processing, a completion notice is returned. This command uses the socket of VISCA. The order of completion notices may be changed if the multiple commands are sent to the same peripheral device.

### VISCA inquiry

This is an inquiry from the controller to the peripheral device.

When the peripheral device receives this type of command, the reply for the inquiry is returned. This command does not use the socket of VISCA. The order of the replies is not changed if a multiple commands are sent.

### VISCA reply

This is an ACK, completion notice, reply, or error reply from the peripheral device to the controller. The classification for sending messages from the peripheral device to the controller is common.

### VISCA device setting command

This is the device setting command from the controller to the peripheral device as follows.

- **Address Set**

Sets the address of the peripheral device, and does not return a reply to the controller. While using VISCA over IP, the Address Set command is not sent from the controller because a Network Change command from the peripheral device that triggers sending command is not issued.

- **IF\_Clear**

Sends the reply message to the controller after clearing, without using VISCA socket.

- **CAM\_VersionInq**

Sends the reply message to the controller, without using VISCA socket.

### Format

These are the specifications of the message header (8 bytes) and payload (1 to 16 bytes).

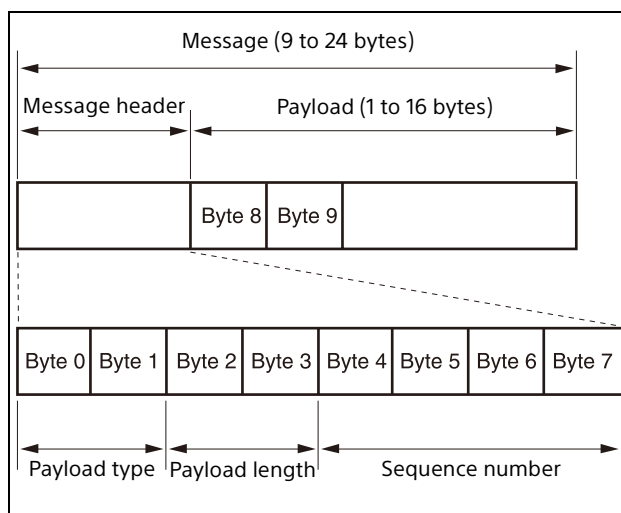

Message structure

### Note

The actual LAN out method is big-endian, LSB first.

### Payload type

Stores the value (Byte 0 and Byte 1) of the following table on the payload division.

Name	Value (Byte 0)	Value (Byte 1)	Description
VISCA command	0x01	0x00	Stores the VISCA command.
VISCA inquiry	0x01	0x10	Stores the VISCA inquiry.
VISCA reply	0x01	0x11	Stores the reply for the VISCA command and VISCA inquiry, or VISCA device setting command.
VISCA device setting command	0x01	0x20	Stores the VISCA device setting command.
Control command	0x02	0x00	Stores the control command.
Control reply	0x02	0x01	Stores the reply for the control command.

### Payload length

Stores the number of bytes (1 to 16) of data that is stored on the payload.

Example: When the payload length is 16 bytes.

Byte 2: 0x00

Byte 3: 0x10

### Sequence number

The controller stores the sequence number that is added every time a message is sent. If the sequence number reaches the limit, next value will be 0. The peripheral device saves the sequence number in the message from the controller, and stores the sequence number of the received message corresponding to the message sent to the controller.

### Payload

Depending on the payload type, the following are stored.

- **VISCA command**  
Stores the packet of the VISCA command.
- **VISCA inquiry**  
Stores the packet of VISCA message.
- **VISCA reply**  
Stores the reply for the command or inquiry (ACK message, completion message, or error message).
- **VISCA device setting command**  
Stores the packet of the VISCA device setting command.
- **Control command**  
The following are stored on the payload division of the control command.

Name	Value	Description
RESET	0x01	Resets the sequence number to 0. The value that was set as the sequence number is ignored.
ERROR	0x0Fpp	pp=01: Abnormality in the sequence number pp=02: Abnormality in the message (message type)

- **Controlled reply**

The following are stored on the payload division of the reply for the control command.

Message	Value	Description
ACK	0x01	Reply for RESET.

## Delivery confirmation

VISCA over IP uses UDP as a communications protocol of the transport layer. Delivery of messages is not guaranteed for the UDP communication. Delivery confirmation and retransmission should be performed on the application.

Normally, when the controller sends a message to the peripheral device, the controller sends the new message after receiving the reply for the last message. You can confirm delivery of messages by managing the time-out waiting for a reply message sent.

If time out occurs on the controller, loss of one of the following messages is considered:

- Command
- ACK message
- Completion message for the command
- Inquiry
- Reply message for the inquiry
- Error message
- Inquiry of the VISCA device setting command
- Reply message of the VISCA device setting command

If time out occurs on the controller, you can infer the lost message and state of the peripheral device by retransmitting the message using the same sequence number. The following table shows the received message and status by retransmission of the lost message, and the reference of correspondence after retransmission for each case. (Except for the case that a time out occurs for reasons other than loss of message.)

Lost message	Received message for retransmission	Status after retransmission	Correspondence after retransmission (Reference)
Command	ACK message	Command is performed by retransmission.	Continue processing.
ACK message	ERROR (Abnormality in the sequence number)	Command has been performed. If only the ACK message is lost, the completion message returns.	If the result by the completion message is needed, retransmit by updating the sequence number.
Completion message for the command	ERROR (Abnormality in the sequence number)	Command has been performed.	If the result by the completion message is needed, retransmit by updating the sequence number.
Inquiry	Reply message	Inquiry is performed by retransmission.	Continue processing.
Reply message for the inquiry	ERROR (Abnormality in the sequence number)	Inquiry has been performed.	If the result by the reply message is needed, retransmit by updating the sequence number.
Error message	Error message	Command is not performed. If the error cause eliminates, normal reply returns (ACK, reply message).	Eliminate the error cause. If normal reply returns, continue processing.
Inquiry of the VISCA device setting command	Reply message of the VISCA device setting command	Inquiry has been performed by retransmission.	Continue processing.
Reply message of the VISCA device setting command	ERROR (Abnormality in the sequence number)	Inquiry has been performed.	If the result by the reply message is needed, retransmit by updating the sequence number.

The SRG series camera has 2 buffers (memories) for the command to deal with advanced uses. When using VISCA over IP, up to 2 commands (including the current command) can be received. Depending on the message from the controller to the peripheral device, there are some messages that do not need to guarantee delivery. However, the peripheral device receives commands from multiple controllers while connected to VISCA over IP. If the multiple commands are send without waiting for the reply, the possibility of non-execution of the command and errors due to buffer overflow become high, because

of limitations of order to receive commands or execution interval of command. It may cause efficiency to be reduced substantially.

## Timing chart

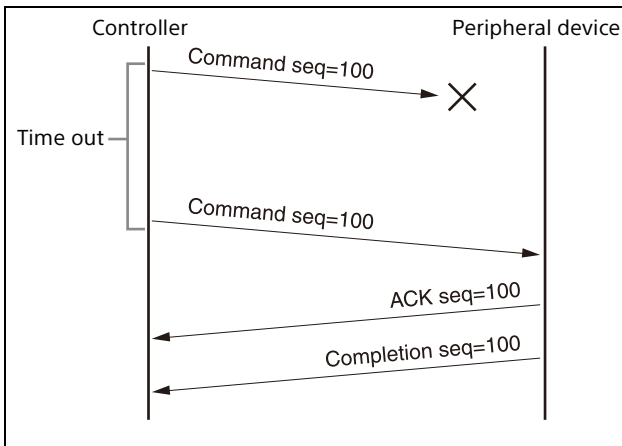

Timing chart (loss of command)

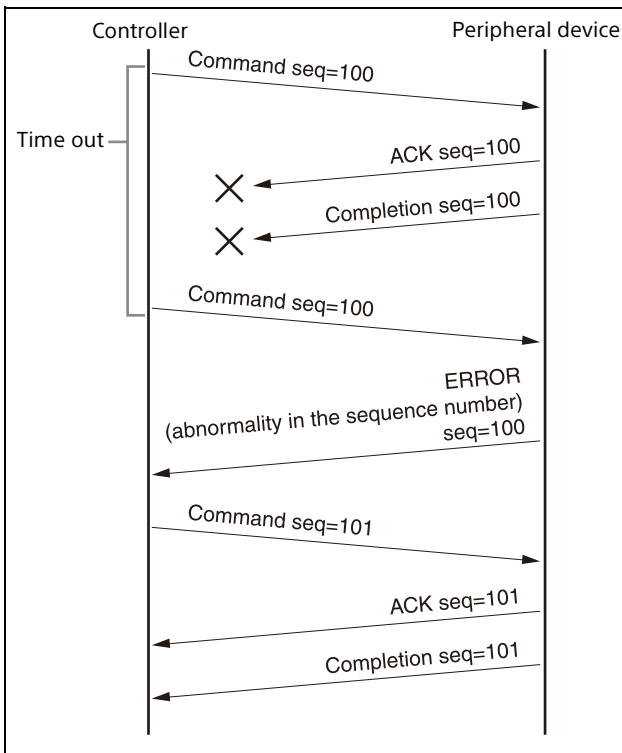

Timing chart (loss of ACK or completion message)

## Limitation

The following are limitations for VISCA over IP as compared with the VISCA specifications.

### Locking the peripheral device's address of the VISCA message to 1

VISCA over IP cannot reflect each address to the address of the VISCA message because up to 112 peripheral devices and 5 controllers are connected. Because of this, the peripheral device's address of VISCA command is locked to 1 when using VISCA over IP. If the peripheral device's address is set to other than 1 for the VISCA command, the peripheral device works

without hindrance since the peripheral device recognizes that its address is set to 1.

### Locking the controller's address of the VISCA message to 0

For the same reason as the peripheral device's address, the controller's address of VISCA command is locked to 0. If the controller's address is set to other than 0, the peripheral device works without hindrance, and the reply address from the peripheral device is always set to 0.

### Prohibition of specifying the broadcast address for the VISCA message

Do not use the broadcast address because it requires the serial communication. Operations under the broadcast address is set to the command are not guaranteed.

### Prohibition of the Address Set for VISCA device setting command

Do not use this command because it requires the serial communication. Operations under the Address Set command is sent are not guaranteed.

### VISCA Network Change command is not supported

Command cannot be issued because it requires the serial communication.

### Expiration time for an ON status of the tally lamp

The tally lamp is turned off if not receiving an ON command from any controller for 15 seconds after receiving an ON command of TALLY ON/OFF.

# VISCA Command List

## Command List

Number in ( ) is MENU display values.

Command Set	Command	Command Packet	Comments	
EXPOSURE	MODE	-	8x 01 04 39 0p FF p: 0=Full Auto, 3=Manual, A=Shutter Priority, B=Iris Priority	
	IRIS	Reset	8x 01 04 0B 00 FF	To return to 19 (F2.0) value
		Up	8x 01 04 0B 02 FF	Open
		Down	8x 01 04 0B 03 FF	Close
		Direct	8x 01 04 4B 00 00 0p FF	pp: Refer to the VISCA Command Setting Values (IRIS) section
	GAIN	Reset	8x 01 04 0C 00 FF	To return to 01 (0 dB) value
		Up	8x 01 04 0C 02 FF	
		Down	8x 01 04 0C 03 FF	
		Direct	8x 01 04 4C 00 00 0p FF	pp: Refer to the VISCA Command Setting Values (GAIN) section
	GAIN LIMIT	Direct	8x 01 04 2C 0p FF	p: Refer to the VISCA Command Setting Values (Gain limit) section
	GAIN POINT	On/Off	8x 01 05 0C 0p FF	p: 2=On, 3=Off
		Position	8x 01 05 4C 0p 0p FF	pp: Refer to the VISCA Command Setting Values (GAIN) section
	HIGH SENSITIVITY	On/Off	8x 01 04 5E 0p FF	p: 2=high-sensitivity mode On, 3=high-sensitivity mode Off
	SHUTTER	Reset	8x 01 04 0A 00 FF	Return to the default value depending on the frame rate of video output
		Up	8x 01 04 0A 02 FF	Fast
		Down	8x 01 04 0A 03 FF	Slow
		Direct	8x 01 04 4A 00 00 0p FF	pp: Refer to the VISCA Command Setting Values (SHUTTER/MIN SHUTTER) section
	MAX SHUTTER	Direct	8x 01 05 2A 00 0p 0p FF	pp: Refer to the VISCA Command Setting Values (MAX SHUTTER) section
	MIN SHUTTER	Direct	8x 01 05 2A 01 0p 0p FF	pp: Refer to the VISCA Command Setting Values (SHUTTER/MIN SHUTTER) section
	AUTO SLOW SHUTTER	Direct	8x 01 04 5A 0p FF	p: 2=On, 3=Off
	AE SPEED	Direct	8x 01 04 5D pp FF	pp: 01 - 30
	EXP COMP	On/Off	8x 01 04 3E 0p FF	p: 2=On, 3=Off
		Reset	8x 01 04 0E 00 FF	To return to 07 (Correction Level 0) value
		Up	8x 01 04 0E 02 FF	
		Down	8x 01 04 0E 03 FF	
		Direct	8x 01 04 4E 00 00 0p 0p FF	pp: 00 - 0E
BACKLIGHT	On/Off	8x 01 04 33 0p FF	p: 2=On, 3=Off	
SPOTLIGHT	On/Off	8x 01 04 3A 0p FF	p: 2=On, 3=Off	

Number in ( ) is MENU display values

Command Set	Command		Command Packet	Comments
EXPOSURE	VISIBILITY ENHANCER	On/Off	8x 01 04 3D 0p FF	p: 6=On, 3=Off
		-	8x 01 04 2D 00 0p 0q 0r 00 00 00 00 FF	p: Effect Level 0 (Dark) - 6 (Bright) q: Brightness compensation selection (0=Very dark, 1=Dark, 2=Standard, 3=Bright) r: Compensation Level (0=Low, 1=Mid, 2=High)
	LOW LIGHT BASIS BRIGHTNESS	On/Off	8x 01 05 39 0p FF	p: 2=On, 3=Off
		Level	8x 01 05 49 0p FF	p: 4 - A
COLOR	WHITE BALANCE MODE	-	8x 01 04 35 0p FF	p: 0=Auto1, 1=Indoor, 2=Outdoor, 3=One Push WB, 4=Auto2, 5=Manual
	ONE PUSH TRIGGER	-	8x 01 04 10 05 FF	One Push WB Trigger
	R.GAIN	Reset	8x 01 04 03 00 FF	To return to 80 (0) value
		Up	8x 01 04 03 02 FF	
		Down	8x 01 04 03 03 FF	
		Direct	8x 01 04 43 00 00 0p 0p FF	pp: 00 (-128) - 80 (0) - FF (127)
	B.GAIN	Reset	8x 01 04 04 00 FF	To return to 80 (0) value
		Up	8x 01 04 04 02 FF	
		Down	8x 01 04 04 03 FF	
		Direct	8x 01 04 44 00 00 0p 0p FF	pp: 00 (-128) - 80 (0) - FF (127)
	SPEED	-	8x 01 04 56 0p FF	p: 1 (Slow) - 5 (Fast)
	OFFSET	Reset	8x 01 7E 01 2E 00 00 FF	To return to 7 (0) value
		Up	8x 01 7E 01 2E 00 02 FF	
		Down	8x 01 7E 01 2E 00 03 FF	
		Direct	8x 01 7E 01 2E 01 0p FF	p: 0 (-7) - 7 (0) - E (+7)
	CHROMA SUPPRESS	-	8x 01 04 5F 0p FF	p: 0 (Off), 1 (Weak) - 3 (Strong)
DETAIL	LEVEL	Reset	8x 01 04 02 00 FF	To return to 7 value
		Up	8x 01 04 02 02 FF	
		Down	8x 01 04 02 03 FF	
		Direct	8x 01 04 42 00 00 0p 0p FF	pp: 00 - 0F
	MODE	Direct	8x 01 05 42 01 0p FF	p: 0=Auto, 1=Manual
	BANDWIDTH	Direct	8x 01 05 42 02 0p FF	p: 0 - 4
	CRISPENING	Direct	8x 01 05 42 03 0p FF	p: 0 - 7
	HV BALANCE	Direct	8x 01 05 42 04 0p FF	p: 5 - 9
	BW BALANCE	Direct	8x 01 05 42 05 0p FF	p: 0 - 4
	LIMIT	Direct	8x 01 05 42 06 0p FF	p: 0 - 7
	HIGHLIGHT DETAIL	Direct	8x 01 05 42 07 0p FF	p: 0 - 4
	SUPER LOW	Direct	8x 01 05 42 08 0p FF	p: 0 - 7
FLICKER CANCEL	-	-	8x 01 04 32 0p FF	p: 2=On, 3=Off
IMAGE STABILIZER	-	-	8x 01 04 34 0p FF	p: 2=On, 3=Off

Number in ( ) is MENU display values.

Command Set	Command		Command Packet	Comments
DEFOG	-	-	8x 01 04 37 0p 0q FF	p: 2=On, 3=Off q: Defog Level 0 (same as 2), 1 (Weak) - 3 (Strong)
HIGH RESOLUTION	-	-	8x 01 04 52 0p FF	p: 2=On, 3=Off
NOISE REDUCTION	LEVEL	-	8x 01 04 53 pp FF	pp: NR Setting 00 (Off), 01 (Weak) - 05 (Strong), 7F (Enables 2D NR/3D NR)
	2D NR/3D NR	-	8x 01 05 53 0p 0q FF	p: 2D NR Level 0 (Off), 1 (Weak) - 5 (Strong) q: 3D NR Level 0 (Off), 1 (Weak) - 5 (Strong)
PICTURE EFFECT	-	-	8x 01 04 63 0p FF	p: 0=Off, 4=Black&White
ZOOM	STOP	-	8x 01 04 07 00 FF	
	TELE	Standard speed	8x 01 04 07 02 FF	
	WIDE	Standard speed	8x 01 04 07 03 FF	
	TELE	Variable speed	8x 01 04 07 2p FF	p: 0 (Low) - 7 (High)
	WIDE	Variable speed	8x 01 04 07 3p FF	p: 0 (Low) - 7 (High)
	DIRECT	-	8x 01 04 47 0z 0z 0z 0z FF	zzzz: Refer to the section of the Zoom Magnification of VISCA Command Setting Values
	MODE <sup>*1</sup>	-	8x 01 04 06 0p FF	p: 3=Optical only, 4=Clear Image Zoom, 2=Digital
	TELE CONVERT <sup>*2</sup>	-	8x 01 7E 04 36 0p FF	p: 2=On, 3=Off

<sup>\*1</sup> Clear Image Zoom and Digital are not available for SRG-A12.

<sup>\*2</sup> TELE CONVERT can be set to On only for the following signal formats.

- 1920×1080/59.94p, 1920×1080/59.94i, 1920×1080/29.97p
- 1920×1080/50p, 1920×1080/50i, 1920×1080/25p
- 1920×1080/23.98p

Number in ( ) is MENU display values.

Command Set	Command		Command Packet	Comments	
FOCUS	MODE	Auto/Manual	8x 01 04 38 pp FF	pp: 02=Auto Focus, 03=Manual Focus, 10=Toggle	
	STOP	-	8x 01 04 08 00 FF		
	FAR	Standard speed	8x 01 04 08 02 FF		
	NEAR	Standard speed	8x 01 04 08 03 FF		
	FAR	Variable speed	8x 01 04 08 2p FF	p: 0 (Low) - 7 (High)	
	NEAR	Variable speed	8x 01 04 08 3p FF	p: 0 (Low) - 7 (High)	
	DIRECT	-	8x 01 04 48 0p 0p 0p 0p FF	pppp: Refer to the section of the Focus Distance of VISCA Command Setting Values	
	ONE PUSH TRIGGER	-	8x 01 04 18 01 FF	One Push AF Trigger	
	FOCUS ∞	-	8x 01 04 18 02 FF		
	NEAR LIMIT	-	8x 01 04 28 0p 0p 0p 0p FF	pppp: Refer to the section of the Focus Distance of VISCA Command Setting Values	
	AF MODE	Mode		8x 01 04 57 0p FF	p: 0=Normal AF, 1=Interval AF, 2=Zoom Trigger AF
		Interval		8x 01 04 27 0p 0p 0q 0q FF	pp: AF operating time 00 (no operation), 01 (1 second) - FF (255 seconds) qq: AF staying time 00 (no suspension), 01 (1 second) - FF (255 seconds)
	AF SENSITIVITY	-	8x 01 04 58 0p FF	p: 2=Normal, 3=Low	
	IR CORRECTION	-	8x 01 04 11 0p FF	p: 0=Standard, 1=IR Light	

Number in ( ) is MENU display values.

Command Set	Command	Command Packet	Comments	
PAN TILT	PAN TILT DRIVE	Up	8x 01 06 01 vv ww 03 01 FF vv: Pan speed 01 (Slow) - 18 (Fast) ww: Tilt speed 01 (Slow) - 17 (Fast)	
		Down	8x 01 06 01 vv ww 03 02 FF vv: Pan speed 01 (Slow) - 18 (Fast) ww: Tilt speed 01 (Slow) - 17 (Fast)	
		Left	8x 01 06 01 vv ww 01 03 FF vv: Pan speed 01 (Slow) - 18 (Fast) ww: Tilt speed 01 (Slow) - 17 (Fast)	
		Right	8x 01 06 01 vv ww 02 03 FF vv: Pan speed 01 (Slow) - 18 (Fast) ww: Tilt speed 01 (Slow) - 17 (Fast)	
		UpLeft	8x 01 06 01 vv ww 01 01 FF vv: Pan speed 01 (Slow) - 18 (Fast) ww: Tilt speed 01 (Slow) - 17 (Fast)	
		UpRight	8x 01 06 01 vv ww 02 01 FF vv: Pan speed 01 (Slow) - 18 (Fast) ww: Tilt speed 01 (Slow) - 17 (Fast)	
		DownLeft	8x 01 06 01 vv ww 01 02 FF vv: Pan speed 01 (Slow) - 18 (Fast) ww: Tilt speed 01 (Slow) - 17 (Fast)	
		DownRight	8x 01 06 01 vv ww 02 02 FF vv: Pan speed 01 (Slow) - 18 (Fast) ww: Tilt speed 01 (Slow) - 17 (Fast)	
		Stop	8x 01 06 01 vv ww 03 03 FF vv: Pan speed 01 (Slow) - 18 (Fast) ww: Tilt speed 01 (Slow) - 17 (Fast)	
		ABS (Absolute Position)	8x 01 06 02 vv 00 0p 0p 0p 0p 0t 0t 0t 0t FF vv: Pan-Tilt speed 01 (Slow) - 18 (Fast) pppp: Pan-coordinate* tttt: Tilt-coordinate*	
		REL (Relative Position)	8x 01 06 03 vv 00 0p 0p 0p 0p 0t 0t 0t 0t FF vv: Pan-Tilt speed 01 (Slow) - 18 (Fast) pppp: Pan-shift amount* tttt: Tilt-shift amount*	
		Home	8x 01 06 04 FF	
	Reset	8x 01 06 05 FF		
	RAMP CURVE	-	8x 01 06 31 0p FF	p: Acceleration and deceleration curve 1=Sharpness
	PAN-TILT SLOW	On/Off	8x 01 06 44 0p FF	p: 2=On, 3=Off
PAN TILT LIMIT	Limit Set	8x 01 06 07 00 0q 0p 0p 0p 0p 0t 0t 0t 0t FF q: Position (1=UpRight, 0=DownLeft) For pppp and tttt, refer to the section of the Pan/Tilt Position of VISCA Command Setting Values		
	Limit Clear	8x 01 06 07 01 0q 07 0F 0F 0F 07 0F 0F 0F FF q: Position (1=UpRight, 0=DownLeft)		
PRESET	RESET	Reset	8x 01 04 3F 00 pp FF pp: PRESET No. to reset - 1 (00 - 63)	
	SET	Set	8x 01 04 3F 01 pp FF pp: PRESET No. to set - 1 (00 - 63)	
	RECALL	Recall	8x 01 04 3F 02 pp FF pp: PRESET No. to recall - 1 (00 - 63)	
	SPEED	Select	8x 01 7E 04 1B 0p FF p: 0=Compatible (specify the speed with the same command as Separate for VISCA, and with an argument of the Preset Recall command for CGI), 1=Separate (operation with individual speed by a preset), 2=Common (operation with common speed to all presets)	
		Separate	8x 01 7E 01 0B pp qq FF pp: PRESET No. -1 (00 - 63) qq: Positioning speed (01 - 19)	
		Common	8x 01 7E 04 1C 0p 0p FF pp: Common Speed (01-19)	
CALL MODE	-	8x 01 7E 04 3B 0p FF p: 2=Freeze (Freeze the image from a camera during recalling), 3=Normal		
PTZ Auto Framing	START/STOP	-	8x 01 7E 04 3A 0p FF p: 1=Start, 0=Stop	

\* Refer to the section of the Pan/Tilt Position of VISCA Command Setting Values.

Number in ( ) is MENU display values.

Command Set	Command		Command Packet	Comments
SYSTEM	VIDEO FORMAT	Select	8x 01 7E 04 32 0p 0p FF	pp: Video Format For pp, refer to the section of the Video output method (video format) of VISCA Command Setting Values
	IR RECEIVE	-	8x 01 06 08 pp FF	pp: 02=On, 03=Off, 10=Toggle
	IMG FLIP	-	8x 01 04 66 0p FF	p: 2=On, 3=Off
	CAMERA ID	-	8x 01 04 22 0p 0p 0p 0p FF	pppp: Camera ID (0000 - FFFF)
MENU	ON/OFF	-	8x 01 06 06 pp FF	p: 2=On, 3=Off, 10=Toggle
	ENTER	-	8x 01 7E 01 02 00 01 FF	
	OSD	-	8x 01 7E 04 76 0p 0q FF	p: 0=SDI, 1=HDMI q: 2=OSD On, 3=OSD Off
IR CUT FILTER	ICR	On/Off	8x 01 04 01 0p FF	p: 2=On (Night), 3=Off (Day)
	AUTO ICR	On/Off	8x 01 04 51 0p FF	p: 2=Auto ICR On, 3=Auto ICR Off
		Threshold	8x 01 04 21 00 00 0p 0p FF	pp: 00 - FF (Threshold) <sup>*1</sup>
TALLY	ON/OFF	-	8x 01 7E 01 0A 00 0p FF	p: 2=On, 3=Off
	LEVEL	-	8x 01 7E 01 0A 01 0p FF	p: 0=OFF, 4=ON (LOW), 5=ON (HIGH)
HDMI	COLOR SPACE	-	8x 01 7E 01 03 00 0p FF	p: 0=YCbCr, 1=RGB
POWER	ON/STANDBY	-	8x 01 04 00 0p FF	p: 2=On, 3=Standby
	STANDBY MODE	-	8x 01 7E 04 50 0p FF	p: 2=Side (When transferring to Standby, move the Pan to the end point <sup>*2</sup> and the Tilt to 0°), 3=Neutral

<sup>\*1</sup> When the value is large, even if the subject is bright, the camera cannot be changed to Day mode. In this case, use the camera by decreasing the value.

<sup>\*2</sup> Aligned to the right end when IMAGE FLIP is Off, and aligned to the left end when IMAGE FLIP is On.

## Inquiry Command List

Number in ( ) is MENU display values.

Inquiry Command	Inquiry Packet	Reply Packet	Comments
EXPOSURE	MODE	8x 09 04 39 FF	y0 50 0p FF p: 0=Full Auto, 3=Manual, A=Shutter Priority, B=Iris Priority
	IRIS	8x 09 04 4B FF	y0 50 00 00 0p 0p FF pp: Refer to the VISCA Command Setting Values (IRIS) section
	GAIN	8x 09 04 4C FF	y0 50 00 00 0p 0p FF pp: Refer to the VISCA Command Setting Values (GAIN) section
	GAIN LIMIT	8x 09 04 2C FF	y0 50 0p FF p: Gain Limit
	GAIN POINT	8x 09 05 0C FF	y0 50 0p FF p: 2=On, 3=Off
		8x 09 05 4C FF	y0 50 0p 0p FF pp: Gain Point Position
	HIGH SENSITIVITY	8x 09 04 5E FF	y0 50 0p FF pp: High Sensitivity
	SHUTTER	8x 09 04 4A FF	y0 50 00 00 0p 0p FF pp: Refer to the VISCA Command Setting Values (SHUTTER/MIN SHUTTER) section
	MAX SHUTTER	8x 09 05 2A 00 FF	y0 50 0p 0p FF pp: Refer to the VISCA Command Setting Values (MAX SHUTTER) section
	MIN SHUTTER	8x 09 05 2A 01 FF	y0 50 0p 0p FF pp: Refer to the VISCA Command Setting Values (SHUTTER/MIN SHUTTER) section
	AUTO SLOW SHUTTER	8x 09 04 5A FF	y0 50 0p FF p: 2=On, 3=Off
	AE SPEED	8x 09 04 5D FF	y0 50 pp FF pp: 01 - 30
	EXP COMP	8x 09 04 3E FF	y0 50 0p FF p: 2=On, 3=Off
		8x 09 04 4E FF	y0 50 00 00 0p 0p FF pp: 00 - 0E
	BACKLIGHT	8x 09 04 33 FF	y0 50 0p FF p: 2=On, 3=Off
	SPOTLIGHT	8x 09 04 3A FF	y0 50 0p FF p: 2=On, 3=Off
	VISIBILITY ENHANCER	8x 09 04 3D FF	y0 50 0p FF p: 6=On, 3=Off
8x 09 04 2D FF		y0 50 00 0p 0q 0r 00 00 00 00 FF p: Effect Level 0 (Dark) - 6 (Bright) q: Brightness compensation selection (0=Very dark, 1=Dark, 2=Standard, 3=Bright) r: Compensation Level (0=Low, 1=Mid, 2=High)	
LOW LIGHT BASIS BRIGHTNESS	8x 09 05 39 FF	y0 50 0p FF p: 2=On, 3=Off	
	8x 09 05 49 FF	y0 50 0p FF p: 4 - A	
COLOR	WHITE BALANCE MODE	8x 09 04 35 FF	y0 50 0p FF p: 0=Auto1, 1=Indoor, 2=Outdoor, 3=One Push WB, 4=Auto2, 5=Manual
	R.GAIN	8x 09 04 43 FF	y0 50 00 00 0p 0p FF pp: 00 (-128) - 80 (0) - FF (127)
	B.GAIN	8x 09 04 44 FF	y0 50 00 00 0p 0p FF pp: 00 (-128) - 80 (0) - FF (127)
	SPEED	8x 09 04 56 FF	y0 50 0p FF p: 1 (Slow) - 5 (Fast)
	OFFSET	8x 09 7E 01 2E FF	y0 50 00 00 00 0p FF p: 0 (-7) - 7 (0) - E (+7)
	CHROMA SUPPRESS	8x 09 04 5F FF	y0 50 0p FF p: 0 (Off), 1 (Weak) - 3 (Strong)

Number in ( ) is MENU display values.

Inquiry Command		Inquiry Packet	Reply Packet	Comments
DETAIL	LEVEL	8x 09 04 42 FF	y0 50 00 00 0p 0p FF	pp: 00 - 0F
	MODE	8x 09 05 42 01 FF	y0 50 0p FF	p: 0=Auto, 1=Manual
	BANDWIDTH	8x 09 05 42 02 FF	y0 50 0p FF	p: 0 - 4
	CRISPENING	8x 09 05 42 03 FF	y0 50 0p FF	p: 0 - 7
	HV BALANCE	8x 09 05 42 04 FF	y0 50 0p FF	p: 5 - 9
	BW BALANCE	8x 09 05 42 05 FF	y0 50 0p FF	p: 0 - 4
	LIMIT	8x 09 05 42 06 FF	y0 50 0p FF	p: 0 - 7
	HIGHLIGHT DETAIL	8x 09 05 42 07 FF	y0 50 0p FF	p: 0 - 4
	SUPER LOW	8x 09 05 42 08 FF	y0 50 0p FF	p: 0 - 7
FLICKER CANCEL	-	8x 09 04 32 FF	y0 50 0p FF	p: 2=On, 3=Off
IMAGE STABILIZER	-	8x 09 04 34 FF	y0 50 0p FF	p: 2=On, 3=Off
DEFOG	-	8x 09 04 37 FF	y0 50 0p 0q FF	p: 2=On, 3=Off q: Defog Level 0 (Min) - 3 (Max)
HIGH RESOLUTION	-	8x 09 04 52 FF	y0 50 0p FF	p: 2=On, 3=Off
NOISE REDUCTION	LEVEL	8x 09 04 53 FF	y0 50 pp FF	pp: NR Setting 00 (Off), 01 (Weak) - 05 (Strong), 7F (Enables 2D NR/3D NR)
	2D NR/3D NR	8x 09 05 53 FF	y0 50 0p 0q FF	p: 2D NR Level 0 (Off), 1 (Weak) - 5 (Strong) q: 3D NR Level 0 (Off), 1 (Weak) - 5 (Strong)
PICTURE EFFECT	-	8x 09 04 63 FF	y0 50 0p FF	p: 0=Off, 4=Black&White
ZOOM	MODE*	8x 09 04 06 FF	y0 50 0p FF	p: 3=Optical only, 4=Clear Image Zoom, 2=Digital
	TELE CONVERT	8x 09 7E 04 36 FF	y0 50 0p FF	p: 2=On, 3=Off
	ZOOM POSITION	8x 09 04 47 FF	y0 50 0z 0z 0z 0z FF	zzzz: Refer to the section of the Zoom Magnification of VISCA Command Setting Values
FOCUS	MODE	8x 09 04 38 FF	y0 50 0p FF	p: 2=Auto Focus, 3=Manual Focus
	FOCUS POSITION	8x 09 04 48 FF	y0 50 0p 0p 0p 0p FF	pppp: Refer to the section of the Focus Distance of VISCA Command Setting Values
	AF MODE	8x 09 04 57 FF	y0 50 0p FF	p: 0=Normal AF, 1=Interval AF, 2=Zoom Trigger AF
	AF MODE INTERVAL	8x 09 04 27 FF	y0 50 0p 0p 0q 0q FF	pp: AF operating time 00 (no operation), 01 (1 second) - FF (255 seconds) qq: AF staying time 00 (no suspension), 01 (1 second) - FF (255 seconds)
	AF SENSITIVITY	8x 09 04 58 FF	y0 50 0p FF	p: 2 (Normal), 3 (Low)
	NEAR LIMIT	8x 09 04 28 FF	y0 50 0p 0p 0p 0p FF	pppp: Refer to the section of the Focus Distance of VISCA Command Setting Values
	IR CORRECTION	8x 09 04 11 FF	y0 50 0p FF	p: 0 (Standard), 1 (IR Light)

\* Clear Image Zoom and Digital are not available for SRG-A12.

Number in ( ) is MENU display values.

Inquiry Command	Inquiry Packet	Reply Packet	Comments	
PAN TILT	POSITION	8x 09 06 12 FF	y0 50 0p 0p 0p 0p 0t 0t 0t 0t FF	Refer to the section of the Pan/ Tilt Position of VISCA Command Setting Values for pppp and tttt
	STATUS	8x 09 06 10 FF	y0 50 pp pp FF	pppp: Refer to the section of the Pan-Tilt status code list
	RAMP CURVE	8x 09 06 31 FF	y0 50 0p FF	p: Acceleration and deceleration curve 1=Sharpness
	PAN-TILT SLOW	8x 09 06 44 FF	y0 50 0p FF	p: 2=On, 3=Off
	PAN TILT LIMIT	8x 09 06 07 0q FF	y0 50 0p 0p 0p 0p 0t 0t 0t 0t FF	q: Position (1=UpRight, 0=DownLeft) Refer to the section of the Pan/ Tilt Position of VISCA Command Setting Values for pppp and tttt
	PAN TILT MAX SPEED	8x 09 06 11 FF	y0 50 pp qq FF	pp: Pan Max Speed fixed value (18) qq: Tilt Max Speed fixed value (17)
PRESET	SPEED SELECT	8x 09 7E 04 1B FF	y0 50 0p FF	p: 0=Compatible (specify the speed with the same command as Separate for VISCA, and with an argument of the Preset Recall command for CGI), 1=Separate (operation with individual speed by a preset), 2=Common (operation with common speed to all presets)
	SPEED SEPARATE	8x 09 7E 01 0B pp FF	y0 50 qq FF	pp: PRESET No. to confirm the speed - 1 (00 - 63) qq: Positioning speed (01 - 19)
	SPEED COMMON	8x 09 7E 04 1C FF	y0 50 0p 0p FF	pp: Common Speed (01 - 19)
	CALL MODE	8x 09 7E 04 3B FF	y0 50 0p FF	p: 2=Freeze (Freeze the image from a camera during recalling), 3=Normal
	LAST RECALL	8x 09 04 3F FF	y0 50 pp FF	pp: PRESET No. last recalled - 1 (00 - 63, 7F)
PTZ Auto Framing	START/STOP	8x 09 7E 04 3A FF	y0 50 0p FF	p: 1=Start, 0=Stop
IR CUT FILTER	STATUS	8x 09 04 01 FF	y0 50 0p FF	p: 2=On (Night), 3=Off (Day)
	AUTO ICR	8x 09 04 51 FF	y0 50 0p FF	p: 2=Auto ICR On, 3=Auto ICR Off
	AUTO ICR THRESHOLD	8x 09 04 21 FF	y0 50 00 00 0p 0p FF	pp: 00 - FF (Threshold)
TALLY	-	8x 09 7E 01 0A FF	y0 50 0p FF	p: 2=On, 3=Off

Number in ( ) is MENU display values.

Inquiry Command		Inquiry Packet	Reply Packet	Comments
SYSTEM	VIDEO FORMAT SELECTABLE	8x 09 7E 04 31 FF	y0 50 0p FF	Whether the setting can be changed by the command of the Video output method (video format) or not. p: 2=Available, 3=Not available
	VIDEO FORMAT SELECT	8x 09 7E 04 32 FF	y0 50 0p 0p FF	pp: Video Format For pp, refer to the section of the Video output method (video format) of VISCA Command Setting Values
	VIDEO FORMAT STATUS	8x 09 7E 04 33 FF	y0 50 0p 0p FF	Current status of the Video output method (video format) pp: Video Format For pp, refer to the section of the Video output method (video format) of VISCA Command Setting Values
	IR RECEIVE	8x 09 06 08 FF	y0 50 0p FF	p: 2=On, 3=Off
	IMG FLIP	8x 09 04 66 FF	y0 50 0p FF	p: 2=On, 3=Off
	CAMERA ID	8x 09 04 22 FF	y0 50 0p 0p 0p 0p FF	pppp: Camera ID (0000 - FFFF)
	CAMERA GENERATION	8x 09 7E 04 30 FF	y0 50 0h 0k 0m 0n 0p 0q 0r 0s 0t 0u uu 0v vv FF	h: Number of camera generation k-t: 0 fixed Ouuu: Model ID 0vvv: Model ID of the similar model when operating with a remote controller
HDMI	COLOR SPACE	8x 09 7E 01 03 FF	y0 50 0p FF	p: 0=YCbCr, 1=RGB
MENU	ON/OFF	8x 09 06 06 FF	y0 50 0p FF	p: 2=On, 3=Off
	OSD	8x 09 7E 04 76 0p FF	y0 50 0q FF	p: 0=SDI, 1=HDMI q: 2=OSD On, 3=OSD Off
POWER	ON/STANDBY	8x 09 04 00 FF	y0 50 0p FF	p: 2=On, 3=Standby
	STANDBY MODE	8x 09 7E 04 50 FF	y0 50 0p FF	p: 2=Side (When Standby is executed, move the Pan to the end point* and the Tilt to 0°), 3=Neutral
SOFTWARE VERSION (CAM_VersionInq)	-	8x 09 00 02 FF	y0 50 pp pp qq qq rr rr 0s FF	pppp: Vendor ID qqqq: Model Code rrrr: ROM version s: Socket Number

\* Aligned to the right end when IMAGE FLIP is Off, and aligned to the left end when IMAGE FLIP is On.

# Block Inquiry Command

## Lens control system inquiry commands.....Inquiry Packet 8x 09 7E 7E 00 FF

Byte	Bit	Comments
0	7	Destination Address
	6	
	5	
	4	
	3	Source Address
	2	
	1	
	0	
1	7	0
	6	1
	5	0
	4	1
	3	0
	2	0
	1	0
	0	0
2	7	0
	6	0
	5	0
	4	0
	3	Zoom Position (HH)
	2	
	1	
	0	
3	7	0
	6	0
	5	0
	4	0
	3	Zoom Position (HL)
	2	
	1	
	0	
4	7	0
	6	0
	5	0
	4	0
	3	Zoom Position (LH)
	2	
	1	
	0	
5	7	0
	6	0
	5	0
	4	0
	3	Zoom Position (LL)
	2	
	1	
	0	

Byte	Bit	Comments
6	7	0
	6	0
	5	0
	4	0
	3	Focus Near Limit (H)
	2	
	1	
	0	
7	7	0
	6	0
	5	0
	4	0
	3	Focus Near Limit (L)
	2	
	1	
	0	
8	7	0
	6	0
	5	0
	4	0
	3	Focus Position (HH)
	2	
	1	
	0	
9	7	0
	6	0
	5	0
	4	0
	3	Focus Position (HL)
	2	
	1	
	0	
10	7	0
	6	0
	5	0
	4	0
	3	Focus Position (LH)
	2	
	1	
	0	
11	7	0
	6	0
	5	0
	4	0
	3	Focus Position (LL)
	2	
	1	
	0	

Byte	Bit	Comments
12	7	0
	6	0
	5	0
	4	0
	3	0
	2	0
	1	0
	0	0
13	7	0
	6	Zoom Mode (H)*
	5	0
	4	AF Mode
	3	
	2	AF Sensitivity
	1	Zoom Mode (L)*
	0	Focus Mode
14	7	0
	6	0
	5	0
	4	0
	3	Low Contrast detection
	2	Preset Recall Executing
	1	Focus Command Executing
	0	Zoom Command Executing
15	7	1
	6	1
	5	1
	4	1
	3	1
	2	1
	1	1
	0	1

\* Fixed at 00 for SRG-A12

**Camera control system inquiry commands.....Inquiry Packet 8x 09 7E 7E 01 FF**

Byte	Bit	Comments
0	7	Destination Address
	6	
	5	
	4	
	3	Source Address
	2	
	1	
	0	
1	7	0
	6	1
	5	0
	4	1
	3	0
	2	0
	1	0
	0	0
2	7	0
	6	0
	5	0
	4	0
	3	R Gain (H)
	2	
	1	
	0	
3	7	0
	6	0
	5	0
	4	0
	3	R Gain (L)
	2	
	1	
	0	
4	7	0
	6	0
	5	0
	4	0
	3	B Gain (H)
	2	
	1	
	0	
5	7	0
	6	0
	5	0
	4	0
	3	B Gain (L)
	2	
	1	
	0	

Byte	Bit	Comments
6	7	0
	6	0
	5	N/A
	4	
	3	White Balance Mode
	2	
	1	
	0	
7	7	0
	6	White Balance Speed
	5	
	4	
	3	Detail Level
	2	
	1	
	0	
8	7	0
	6	0
	5	0
	4	0
	3	Exposure Mode
	2	
	1	
	0	
9	7	0
	6	0
	5	High Sensitivity
	4	Visibility Enhancer
	3	N/A
	2	Backlight
	1	Exp Comp On/Off
	0	Auto Slow Shutter
10	7	0
	6	0
	5	Shutter Position
	4	
	3	
	2	
	1	Iris Position
	0	
0		
11	7	0
	6	0
	5	0
	4	Iris Position
	3	
	2	
	1	
	0	

Byte	Bit	Comments
12	7	0
	6	0
	5	0
	4	Gain Position
	3	
	2	
	1	
	0	
13	7	0
	6	0
	5	N/A
	4	
	3	
	2	
	1	
	0	
14	7	0
	6	0
	5	0
	4	0
	3	Exp Comp Level
	2	
	1	
	0	
15	7	1
	6	1
	5	1
	4	1
	3	1
	2	1
	1	1
	0	1

**Other block inquiry commands.....Inquiry Packet 8x 09 7E 7E 02 FF**

Byte	Bit	Comments
0	7	Destination Address
	6	
	5	
	4	
	3	Source Address
	2	
	1	
	0	
1	7	0
	6	1
	5	0
	4	1
	3	0
	2	0
	1	0
	0	0
2	7	0
	6	0
	5	Spotlight
	4	Flicker Cancel
	3	N/A
	2	Auto ICR
	1	0
	0	Power
3	7	0
	6	Image Stabilizer
	5	0
	4	IR Cut Filter
	3	N/A
	2	
	1	0
	0	0
4	7	0
	6	0
	5	N/A
	4	
	3	
	2	0
	1	
	0	
5	7	0
	6	0
	5	0
	4	0
	3	Picture Effect
	2	
	1	
	0	

Byte	Bit	Comments
6	7	0
	6	0
	5	0
	4	0
	3	0
	2	0
	1	0
	0	0
7	7	0
	6	0
	5	0
	4	0
	3	White Balance Offset
	2	
	1	
	0	
8	7	0
	6	0
	5	0
	4	0
	3	Camera ID (HH)
	2	
	1	
	0	
9	7	0
	6	0
	5	0
	4	0
	3	Camera ID (HL)
	2	
	1	
	0	
10	7	0
	6	0
	5	0
	4	0
	3	Camera ID (LH)
	2	
	1	
	0	
11	7	0
	6	0
	5	0
	4	0
	3	Camera ID (LL)
	2	
	1	
	0	

Byte	Bit	Comments
12	7	0
	6	0
	5	0
	4	1
	3	0
	2	1
	1	1
	0	N/A
13	7	0
	6	0
	5	0
	4	0
	3	0
	2	0
	1	0
	0	0
14	7	0
	6	0
	5	0
	4	0
	3	0
	2	0
	1	0
	0	0
15	7	1
	6	1
	5	1
	4	1
	3	1
	2	1
	1	1
	0	1

**Other enlargement inquiry commands (1/2) ..... Inquiry Packet 8x 09 7E 7E 03 FF**

Byte	Bit	Comments
0	7	Destination Address
	6	
	5	
	4	
	3	Source Address
	2	
	1	
	0	
1	7	0
	6	1
	5	0
	4	1
	3	0
	2	0
	1	0
	0	0
2	7	0
	6	0
	5	0
	4	0
	3	N/A
	2	
	1	
	0	
3	7	0
	6	0
	5	0
	4	0
	3	N/A
	2	
	1	
	0	
4	7	0
	6	0
	5	0
	4	0
	3	AF operating time (H)
	2	
	1	
	0	
5	7	0
	6	0
	5	0
	4	0
	3	AF operating time (L)
	2	
	1	
	0	

Byte	Bit	Comments
6	7	0
	6	0
	5	0
	4	0
	3	AF staying time (H)
	2	
	1	
	0	
7	7	0
	6	0
	5	0
	4	0
	3	AF staying time (L)
	2	
	1	
	0	
8	7	0
	6	Noise Reduction 2D NR Level
	5	
	4	
	3	
	2	
	1	
	0	
9	7	0
	6	Noise Reduction 3D NR Level
	5	
	4	
	3	
	2	
	1	
	0	
10	7	0
	6	0
	5	0
	4	0
	3	0
	2	N/A
	1	0
	0	Image Flip Status
11	7	0
	6	0
	5	0
	4	0
	3	0
	2	N/A
	1	
	0	Image Flip

Byte	Bit	Comments
12	7	0
	6	0
	5	AE Speed
	4	
	3	
	2	
	1	Noise Reduction Level
	0	
13	7	0
	6	0
	5	0
	4	0
	3	High Sensitivity
	2	Noise Reduction Level
	1	
	0	
14	7	0
	6	Chroma Suppress
	5	
	4	
	3	
	2	
	1	
	0	
15	7	1
	6	1
	5	1
	4	1
	3	1
	2	1
	1	1
	0	1

**Other enlargement inquiry commands (2/2) ..... Inquiry Packet 8x 09 7E 7E 04 FF**

Byte	Bit	Comments
0	7	Destination Address
	6	
	5	
	4	
	3	Source Address
	2	
	1	
	0	
1	7	0
	6	1
	5	0
	4	1
	3	0
	2	0
	1	0
	0	0
2	7	0
	6	0
	5	0
	4	0
	3	0
	2	0
	1	Visibility Enhancer
	0	
3	7	0
	6	0
	5	0
	4	0
	3	0
	2	0
	1	0
	0	0
4	7	0
	6	0
	5	0
	4	0
	3	0
	2	VE Effect Level
	1	
	0	
5	7	
	6	0
	5	0
	4	0
	3	0
	2	0
	1	VE Brightness Compensation Selection
	0	

Byte	Bit	Comments
6	7	0
	6	0
	5	0
	4	0
	3	0
	2	0
	1	VE Compensation Level
	0	
7	7	0
	6	0
	5	0
	4	0
	3	0
	2	0
	1	0
	0	Defog
8	7	0
	6	0
	5	0
	4	0
	3	0
	2	0
	1	Defog Level
	0	
9	7	0
	6	0
	5	Min Shutter
	4	
	3	
	2	
	1	
	0	
10	7	0
	6	0
	5	Max Shutter
	4	
	3	
	2	
	1	
	0	
11	7	0
	6	0
	5	Detail HV Balance
	4	
	3	
	2	Detail Crispening
	1	
	0	

Byte	Bit	Comments
12	7	0
	6	0
	5	Detail Limit
	4	
	3	
	2	Detail BW Balance
	1	
	0	
13	7	0
	6	0
	5	Detail Highlight Detail
	4	
	3	
	2	Detail Super Low
	1	
	0	
14	7	0
	6	0
	5	0
	4	0
	3	Detail Mode
	2	Detail Bandwidth
	1	
	0	
15	7	1
	6	1
	5	1
	4	1
	3	1
	2	1
	1	1
	0	1



## Notes

- The camera name (NAME) is to be up to 8 characters of alphanumeric characters and spaces.
- The camera's IP address of the network setting and camera name cannot be changed when WRITE of Inquiry reply is set to off.
- WRITE turns to off automatically when 20 minutes have passed after turning on the camera and does not accept the network setting.
- Turning WRITE to off using the CGI command is also possible. When turning to off with the CGI command, the camera does not accept the network setting soon after turning on the camera. Improper changes can be prevented by turning WRITE to off after setting the IP address of the camera.

---

# CGI

---

## Advance Preparation

This document provides information about how to control this camera remotely via network and stream video/audio by using CGI commands supported by this camera and RTSP function. To use CGI commands and RTSP streaming function, some pre-configurations are required. These pre-configurations are described below.

## IP Address Settings by RM-IP Setup Tool

To enable the device to communicate with the camera appropriately, IP address settings is required. Set IP address based on your network environment using RM-IP Setup Tool. For details, refer to "RM-IP Setup Tool Guide."

## Note

To set IP address via Admin menu on Web browser, refer to "Network tab" under "Network menu" in Operating Instructions.

## Setting the Initial Password

Setting the administrator's password is required when operating this camera for the first time. Access to the cameras using Web browser. To access, enter the IP address of the cameras to the address bar in the Web browser, then press Enter.

Entering the user name and password is required. Enter the administrator's user name and leave the password blank for the first login.

Admin username: admin  
Password: blank space

When you log in, setting of the administrator's password is required. The following letters are available for passwords. Set 8 to 64 characters for the password including alphabetical capital letters, lower case letters, and numbers.

- Alphanumeric
- Symbol (!\$%`\*+-. /<=>?@[ ]^\_{ }~)

When you press "OK," the user setting will be changed. Once the setting is changed, you will be requested to enter admin username and password again. Enter the admin username and password you changed in the previous step.

## Changing the Setting of Referer Check

As default, HTTP CGI command delivery checks the requests by checking Referer field in HTTP header to make sure that they are available only via Web page built in the cameras. You can change the setting to prevent CGI requests from being denied by this Referer check function.

For more information on how to change the setting of Referer check function via Admin setting menu on Web browser, refer to "Referer check tab" under "Security menu" in Operating Instructions.

If you use CGI commands with Referer check enabled, you can do so by adding Referer header like below when you create CGI request.

```
Referer: http://<camera_address>/\r\n
```

Where <camera\_address> is the IP address of the cameras (when HTTP port number is 80).

## About Authentication

The camera supports HTTP/RTSP Digest authentication defined by IETF RFC 2617. To use CGI commands on the camera, authentication at the necessary level is required. When you build software to achieve CGI command communication with the camera, build HTTP header to authenticate appropriately for HTTP 401 Unauthorized response as the response of command request.

To use RTSP streaming function supported by the camera, authentication at the necessary level should be performed based on the RTSP authentication setting. When you build software to achieve RTSP streaming function between the cameras build RTSP header to authenticate appropriately for RTSP 401 Unauthorized response as the response of command request. For more information to change RTSP authentication function settings via Admin settings menu using Web browser, refer to [RTSP] - [Authentication] under "Stream Menu" in Operating Instructions.

### Note

If authentication errors are repeated from the same computer, the subsequent request may be regarded as Brute-force attack. Build the software to add credential information with appropriate user/password in case of HTTP 401 response reception. For more information on how to change the setting of Brute-force attack protection function via Admin setting menu on Web browser, refer to "Brute-force attack protection tab" under "Security menu" in Operating Instructions.

# Setting/Inquiring by CGI Commands

## Setting by Commands

Set the camera by describing the CGI commands following the syntax below. It is possible to transmit several parameters at one time if the parameter has the same CGI name (part of <cgi> of Syntax). In this case, it is necessary to insert "&" between each <parameter>=<value>.

### Method

GET/POST

### Syntax

```
http://<camera_address>/command/  
<cgi>?<parameter>=<value>[&<parameter>=<value>...]  
or  
http://<camera_address>/command/  
<cgi>?<parameter>=<value1,value2,...,valueN>
```

When <cgi> is ptzautoframing.cgi or ptzautoframingexe.cgi, /command/ becomes /analytics/.

### Parameters

Refer to "CGI Commands" for details. Note that angle brackets in the table "CGI Commands," "<" and ">," mean that a string between one pair of angle brackets is just a symbol for numbers, but not parameter name itself. For example, if a parameter name is described as SampleParam<n>, for actual usage, SampleParam1, SampleParam2, ... are valid expressions.

## Inquiring by Commands

The following Inquiry command is used to get current status of the camera. The item which has an inquiry parameter in "CGI Commands" can be inquired as its current settings. As a response format, "standard format" and "JS (Java Script) parameter format" which are selectable arbitrarily are supported.

### Method

GET/POST

## Syntax1 (standard format)

```
http://<camera_address>/command/inquiry.cgi?inq=
<Inquiry>[&inq=<Inquiry>...]
```

When <inquiry> is ptzautoframing, /commmand/ becomes /analytics/.

The response is as follows in the case of standard format.

```
HTTP/1.0 200 OK\r\n
Content-Type: text/plain\r\n
Content-Length: <len>\r\n
\r\n
<parameter>=<value>[&<parameter>=<value>&<para
meter>=<value>...]
```

## Syntax2 (JS parameter format)

```
http://<camera_address>/command/
inquiry.cgi?inqjs=<Inquiry>[&inqjs=<Inquiry>...]
```

When <inquiry> is ptzautoframing, /commmand/ becomes /analytics/.

The response is as follows in the case of JS parameter format.

```
HTTP/1.0 200 OK\r\n
Content-Type: text/plain\r\n
Content-Length: <len>\r\n
\r\n
var <parameter>="<value>"\r\n
var <parameter>="<value>"\r\n
var <parameter>="<value>"\r\n
:
```

# CGI Command List

## audio.cgi

Setting (Set): command/audio.cgi?<Parameter>=<Value>

Inquiry (Inq): command/inquiry.cgi?inq=audio

Parameter	Set Inq	Value	Description
MicLineSelect	Set Inq	mic, <b>line</b>	Sets the level of the audio input signal.  mic : MIC input line : LINE input
AudioInVolume	Set Inq	<b>0</b> -10 to 10	Sets the audio volume of the audio input when MicLineSelect is set to mic.
AutoLevelControl	Set Inq	<b>on</b> , off	Turns on/off the function for setting the audio input level to an appropriate volume automatically.
AudioEqualizer	Set Inq	<b>off</b> , 1, 2	Sets the processing of frequency characteristics of the input audio.  off : Does not change the frequency characteristics. 1 : Reduces the low-pass, diminishes the noise of the air conditioning equipment, etc. 2 : Reduces the low-pass and high-pass, emphasizes the human voice clearer.

## codeconfig.cgi

Setting (Set): command/codeconfig.cgi?<Parameter>=<Value>

Inquiry (Inq): command/inquiry.cgi?inq=codeconfig

Parameter	Set Inq	Value	Description
MotionJpegAvailability	Inq	0, 1	Returns whether getting Motion Jpeg of Image 3 is possible or not.  0 : Not possible. 1 : Possible.
ImageCodec1	Set Inq	<b>h264</b> , h265	Sets the video codec of Image 1.  h264 : H.264 h265 : H.265  * When StreamMode is set to srt-caller or srt-listener, the value returns to the initial one.
ImageCodec2	Set Inq	h264, h265, <b>off</b>	Sets the video codec of Image 2.  h264 : H.264 h265 : H.265 off : Off  * When StreamMode is set to srt-caller or srt-listener, the value returns to the initial one.
ImageCodec3	Set Inq	<b>jpeg</b>	Sets the video codec of Image 3.  jpeg : Fixing to Motion Jpeg

Parameter	Set Inq	Value	Description
ImageSize1	Set Inq	<b>3840,2160</b> , 1920,1080, 1280,720, 640,360	Sets the image size of the video stream corresponding to Image 1.  * The available setting values are limited by the video output format. * Refer to the item "IMAGE SIZE" of CGI Command Setting Values. * When StreamMode is set to srt-caller or srt-listener, the value returns to the initial one.
ImageSize2	Set Inq	<b>3840,2160</b> , 1920,1080, 1280,720, 640,360	Sets the image size of the video stream corresponding to Image 2.  * The available setting values are limited by the video output format. * Refer to the item "IMAGE SIZE" of CGI Command Setting Values. * When StreamMode is set to srt-caller or srt-listener, the value returns to the initial one.
ImageSize3	Set Inq	<b>1280,720</b> , 640,360	Sets the image size of the video stream corresponding to Image 3.  * Refer to the item "IMAGE SIZE" of CGI Command Setting Values.
FrameRate1	Set Inq	The available setting values depend on the video output format.  5, 15, 30, <b>60</b> (59.94p, 59.94i) 5, 15, <b>30</b> (29.97p) 5, 12.5, 25, <b>50</b> (50p, 50i) 5, 12.5, <b>25</b> (25p) 6, 12, <b>24</b> (23.98p)	Sets the frame rate (frame/second) of the video stream corresponding to image 1.  * When StreamMode is set to srt-caller or srt-listener, the value returns to the initial one.
FrameRate2	Set Inq	The available setting values depend on the video output format.  5, 15, 30, <b>60</b> (59.94p, 59.94i) 5, 15, <b>30</b> (29.97p) 5, 12.5, 25, <b>50</b> (50p, 50i) 5, 12.5, <b>25</b> (25p) 6, 12, <b>24</b> (23.98p)	Sets the frame rate (frame/second) of the video stream corresponding to image 2.  * When StreamMode is set to srt-caller or srt-listener, the value returns to the initial one.
FrameRate3	Set Inq	The available setting values depend on the video output format.  5, 15, 30, <b>60</b> (59.94p, 59.94i) 5, 15, <b>30</b> (29.97p) 5, 12.5, 25, <b>50</b> (50p, 50i) 5, 12.5, <b>25</b> (25p) 6, 12, <b>24</b> (23.98p)	Sets the frame rate (frame/second) of the video stream corresponding to image 3.
H264Profile1	Set Inq	<b>high</b> , main, baseline	Sets the H.264 profile of Image 1.  high : High profile main : Main profile baseline : Baseline profile
H264Profile2	Set Inq	<b>high</b> , main, baseline	Sets the H.264 profile of Image 2.  high : High profile main : Main profile baseline : Baseline profile

Parameter	Set Inq	Value	Description
H265Profile1	Set Inq	<b>main</b>	Sets the H.265 profile of Image 1. main : Fixing to main profile.
H265Profile2	Set Inq	<b>main</b>	Sets the H.265 profile of Image 2. main : Fixing to main profile.
CBR1	Set Inq	on, <b>off</b>	Sets the bit rate restriction mode of Image 1.  on : Performs the bit rate restriction by CBR off : Performs the bit rate restriction by VBR  * When StreamMode is set to srt-caller or srt-listener, the value returns to the initial one. * When StreamMode is set to srt-caller or srt-listener, cannot change to VBR.
CBR2	Set Inq	on, <b>off</b>	Sets the bit rate restriction mode of Image 2.  on : Performs the bit rate restriction by CBR off : Performs the bit rate restriction by VBR  * When StreamMode is set to srt-caller or srt-listener, the value returns to the initial one. * When StreamMode is set to srt-caller or srt-listener, cannot change to VBR.
BitRate1	Set Inq	<b>16000</b> 512 to 50000	Sets the bit rate of Image 1. (unit: kbps) When CBR1 is set to on, this parameter is valid.
BitRate2	Set Inq	<b>8000</b> 512 to 50000	Sets the bit rate of Image 2. (unit: kbps) When CBR2 is set to on, this parameter is valid.
H264Quality1	Set Inq	<b>6</b> 1 to 10	Sets the H.264 VBR (variable bit rate) picture quality of Image 1. When CBR1 is set to off, this parameter is valid.  * The higher the value, the quality is improved. However, the amount of the generated data increases.
H264Quality2	Set Inq	<b>6</b> 1 to 10	Sets the H.264 VBR (variable bit rate) picture quality of Image 2. When CBR2 is set to off, this parameter is valid.  * The higher the value, the quality is improved. However, the amount of the generated data increases.
H265Quality1	Set Inq	<b>6</b> 1 to 10	Sets the H.265 VBR (variable bit rate) picture quality of Image 1. When CBR1 is set to off, this parameter is valid.  * The higher the value, the quality is improved. However, the amount of the generated data increases.

Parameter	Set Inq	Value	Description
H265Quality2	Set Inq	<b>6</b> 1 to 10	Sets the H.265 VBR (variable bit rate) picture quality of Image 2. When CBR2 is set to off, this parameter is valid.  * The higher the value, the quality is improved. However, the amount of the generated data increases.
JpegQuality3	Set Inq	<b>6</b> 1 to 10	Sets the Motion Jpeg's picture quality of Image 3.  * The higher the value, the quality is improved. However, the amount of the generated data increases.
IFrameInterval1	Set Inq	<b>1</b> 0 to 5	Sets the I picture interval of Image 1. (unit: second)  * When setting to 0, the IFrameRatio1 setting is valid.
IFrameInterval2	Set Inq	<b>1</b> 0 to 5	Sets the I picture interval of Image 2. (unit: second)  * When setting to 0, the IFrameRatio2 setting is valid.
IFrameRatio1	Set Inq	<b>30</b> 15 to 300	Sets the interval to which I picture of Image 1 is inserted. (unit: frame)  * When IFrameInterval1 is set to 0, operates in the IFrameRatio1 setting.
IFrameRatio2	Set Inq	<b>30</b> 15 to 300	Sets the interval to which I picture of Image 2 is inserted. (unit: frame)  * When IFrameInterval2 is set to 0, operates in the IFrameRatio2 setting.
InsertIFrame1	Set	on	Inserts I picture to the video stream of Image 1.
InsertIFrame2	Set	on	Inserts I picture to the video stream of Image 2.
ImageCodecMaxNum	Inq	3	Returns the maximum number of the available video output.
ImageCodecNum	Inq	3	Returns the number of the video output which can be enabled.
AudiIn	Set Inq	on, <b>off</b>	Sets whether the audio input is valid or not.  on : Valid off : Invalid
AudInCodec	Set Inq	<b>aac48_128</b> , aac48_256	Sets the audio codec mode and bitrate of audio input.  aac48_128 : AAC 48 kHz (128 kbps) aac48_256 : AAC 48 kHz (256 kbps)

## datetime.cgi

Setting (Set): command/datetime.cgi?<Parameter>=<Value>

Inquiry (Inq): command/inquiry.cgi?inq=datetime

Parameter	Set Inq	Value	Description
GmTime	Set Inq	YYMMDDhhmmssW	Sets or inquires the date and time by Coordinate Universal Time (UTC).  YYMMDD : Year, Month, Day [000101 - 380119] (Defined by DateFormat.) hhmmss : Hour, minute, second (24 hours) W : Week (Sunday=0, Monday=1, ....., Saturday=6) When you enter the wrong value on W, the value is corrected automatically.
Time	Set Inq	YYMMDDhhmmssW	Sets or inquires the date and time by your local time.  YYMMDD : Year, Month, Day [000101 - 380119] (Defined by DateFormat.) hhmmss : Hour, minute, second (24 hours) W : Week (Sunday=0, Monday=1, ....., Saturday=6) When you enter the wrong value on W, the value is corrected automatically.
DateFormat	Set Inq	<b>ymd</b> , mdy, dmy	Sets the display format of time and day.  ymd: YY-MM-DD mdy: MM-DD-YY dmy: DD-MM-YY
TimeZone	Set Inq	* Refer to the item "TIME ZONE" of CGI Command Setting Values.	Sets the timezone.
NtpService	Set Inq	<b>on</b> , <b>off</b>	Sets whether to synchronize the NTP server or not.  on : Synchronizes. off : Does not synchronize.
NtpAuto	Set Inq	<b>on</b> , <b>off</b>	Sets whether to get the IP address of the NTP (Network Time Protocol) server from DHCP (Dynamic Host Configuration Protocol) server or not.  on : Gets the IP address. off : Does not get the IP address.
NtpServer	Set Inq	0 to 63 characters	Sets NTP server by IPv4 address or host name style. Allows 63 or less alphanumeric characters to be set.

## project.cgi

Setting (Set): command/project.cgi?<Parameter>=<Value>

Inquiry (Inq): command/inquiry.cgi?inq=project

Parameter	Set Inq	Value	Description
VideoFormatSelectable	Inq	0, 1	Returns whether the video output format can be changed by SelectVideoFormat or not.  0 : Cannot be changed. 1 : Can be changed.
SelectVideoFormat	Set Inq	* Refer to the item "VIDEO OUTPUT FORMAT" of CGI Command Setting Values.	Sets the video output format.
VideoFormat	Inq	* Refer to the item "VIDEO OUTPUT FORMAT" of CGI Command Setting Values.	Returns the selected video output format using the SYSTEM SELECT switch and SDI level setting switch.
HdmiColor	Set Inq	<b>ycbcr</b> , rgb	Sets the color space of HDMI output video.  ycbcr: YCbCr rgb : RGB

## property.cgi

Setting (Set): command/property.cgi?<Parameter>=<Value>

Inquiry (Inq): command/inquiry.cgi?inq=property

Parameter	Set Inq	Value	Description
StandbyMode	Set Inq	side, <b>neutral</b>	Sets whether the pan is moved to the end position or not when changing to the standby status.  side : Moves to the end position. neutral : Does not move to the end position.
IRReceive	Set Inq	<b>on</b> , off	Sets whether the signal from the infrared remote control commander is received or not.  on : Receives the signal. off : Does not receive the signal.
SdiOsd	Set Inq	<b>on</b> , off	Sets whether OSD is displayed in SDI OUT output video or not.  on : Displays OSD. off : Does not display OSD.
HdmiOsd	Set Inq	<b>on</b> , off	Sets whether OSD is displayed in HDMI output video or not.  on : Displays OSD. off : Does not display OSD.

## ptzautoframing.cgi

Setting (Set): analytics/ptzautoframing.cgi?<Parameter>=<Value>

Inquiry (Inq): analytics/inquiry.cgi?inq=ptzautoframing

Parameter	Set Inq	Value	Description
PtzAutoFraming	Set Inq	on, <b>off</b>	Starts or finishes tracking of PTZ Auto Framing.  on : Starts tracking of PTZ Auto Framing. off : Finishes tracking of PTZ Auto Framing.
PtzAutoFramingAutoStartEnable	Set Inq	on, <b>off</b>	Starts PTZ Auto Framing automatically when the camera's Power turns on.  on : Automatically starts tracking of PTZ Auto Framing. off : Automatically finishes tracking of PTZ Auto Framing.
PtzAutoFramingInitialSetup	Set Inq	<b>uninitialized</b> , initialized	Confirms whether the initial setting of PTZ Auto Framing is complete or not.  uninitialized : The initial setting of PTZ Auto Framing is not complete. initialized : The initial setting of PTZ Auto Framing is complete.
PtzAutoFramingObjectPosition	Set	[Value1] 0 to 10000  [Value2] 0 to 10000	Tracks the person near the area you tapped as a tracking subject.  [Value1] Abscissa [Value2] Ordinate  The value is a coordinate inside the camera's angle of view. A coordinate in which the screen's vertical and horizontal zones of the upper right (0,0) and lower right (10000,10000) are divided by a fraction per 10000.
PtzAutoFramingFaceIndicatorEnable3	Set Inq	<b>on</b> , off	Performs the superimposing setting of the face indicator for the streaming video output.  on : Perform superimposing. off : Does not perform superimposing.
PtzAutoFramingShotMode	Set Inq	closeup, waist, <b>fullbody</b>	Sets the object size of PTZ Auto Framing.  closeup : Closeup waist : Upper half of the body fullbody : Fullbody
PtzAutoFramingAdjustObjectVertical	Set Inq	height1, height2, height3, height4	Sets the height of the object's face for PTZ Auto Framing.  The height of the object's face of "height1" is the lowest and "height4" is the highest. The item differs depending on the PtzAutoFramingShotMode setting.  The setting, the setting item, and the choice of PtzAutoFramingShotMode (closeup) <b>height1</b> (waist) height1, height2, height3, <b>height4</b> (fullbody) height1, height2, <b>height3</b> , height4

Parameter	Set Inq	Value	Description
PtzAutoFramingAdjustObjectSize	Set Inq	size1, size2, size3, size4	<p>Sets the object size of PTZ Auto Framing.</p> <p>The object size of "size1" is the smallest and "size4" is the biggest. The item differs depending on the PtzAutoFramingShotMode setting.</p> <p>The setting, the setting item, and the choice of PtzAutoFramingShotMode (closeup) size1, <b>size2</b>, size3 (waist) size1, <b>size2</b>, size3 (fullbody) size1, <b>size2</b>, size3, size4</p>
PtzAutoFramingAdjustObject Horizontal	Set Inq	left2, left1, <b>center</b> , right1, right2	<p>Sets the object's horizontal position for PTZ Auto Framing.</p> <p>The object is positioned at the left end while selecting "left2", at the center while "center", and at the right end while "right2".</p>
PtzAutoFramingDetectionArea	Set Inq	<p>[Value1] 0 to 8000</p> <p>[Value2] 0 to 8000</p> <p>[Value3] 2000 to <b>10000</b></p> <p>[Value4] 2000 to <b>10000</b></p>	<p>Sets the detection area of PTZ Auto Framing.</p> <p>Specifies the rectangle inside the camera's angle of view by the top left coordinate, width, and height.</p> <p>[Value1] Abscissa of the detection area's top left [Value2] Ordinate of the detection area's top left [Value3] Width of the detection area [Value4] Height of the detection area</p>
PtzAutoFramingTriggerType	Set Inq	<b>auto</b> , manual	<p>Sets the tracking object's selection type for PTZ Auto Framing.</p> <p>auto : Automatic specification manual: Manual specification</p>
PtzAutoFramingFaceLostWaitTime	Set Inq	0 to 60	<p>Sets the tracking time-out interval of PTZ Auto Framing.</p> <p>[Wait Time] is the lost time of human detection and [Tracking Timeout] is the interval from when the face detection cannot be performed. The setting between 0 to 60 seconds can be configured.</p>
PtzAutoFramingDetectionRestartTime	Set Inq	0 to 600	<p>Sets the tracking enforcement restart time for PTZ Auto Framing.</p> <p>The setting between 0 to 600 seconds can be configured.</p>
PtzAutoFramingLostWaitTime	Set Inq	<b>6</b> 1 to 60	<p>Sets the tracking lost waiting time for PTZ Auto Framing.</p> <p>The setting between 1 to 60 seconds can be configured.</p>

Parameter	Set Inq	Value	Description
PtzAutoFramingTrackingStatus	Inq	idle, missing, preparing, searching, tracking, waiting	Gets the operating status of PTZ Auto Framing.  idle : Under suspension missing : While tracking lost preparing : While preparing the tracking searching : While searching tracking : While tracking waiting : Waiting for the tracking object to be selected
PtzAutoFramingMinDetectionArea	Inq	[Value1] 2000  [Value2] 2000	Returns the detection area's minimum size of PTZ Auto Framing.  [Value1] The minimum value of the detection area's width  [Value2] The minimum value of the detection area's height

### ptzautoframingexe.cgi

Setting (Set): analytics/ptzautoframingexe.cgi?<Parameter>=<Value>

Parameter	Set Inq	Value	Description
PtzAutoFramingRestart	Set	on	Forces the status to "While searching the tracking object" while performing PTZ AutoFraming.
PtzAutoFramingDecideStartPosition	Set	on	Preserves the tracking start position of PTZ AutoFraming.
PtzAutoFramingMoveStartPosition	Set	on	Moves to the tracking start position of PTZ AutoFraming.

### pullinquiry.cgi

Setting (Set): command/pullinquiry.cgi?<Parameter>=<Value>

Parameter	Set Inq	Value	Description
SubscriptionId	Set	-	Displays for Web App. Do not set this.

### rtspconfig.cgi

Setting (Set): command/rtspconfig.cgi?<Parameter>=<Value>

Inquiry (Inq): command/inquiry.cgi?inq=rtspconfig

Parameter	Set Inq	Value	Description
RTSPPort	Set Inq	<b>554</b> , 1024 to 65534	Sets the port number to use for RTSP streaming. *1
RTSPTimeout	Set Inq	<b>60</b> 0 to 600	Sets the time-out period by Keep Alive command of RTSP streaming (unit: second).  When setting to 0, the camera does not regard that RTSP session is cut off if not receiving the Keep Alive command (RTSP GET_PARAMETER/SET_PARAMETER, etc.).

Parameter	Set Inq	Value	Description
AuthenRTSP	Set Inq	on, off	Sets whether the RTSP authentication is set to on or off.
RTSPUcVideoPort1	Set Inq	51000 1024 to 65534	Sets the port to use for RTSP/RTP(UDP) unicast streaming of image 1. *1 *2
RTSPUcVideoPort2	Set Inq	53000 1024 to 65534	Sets the port to use for RTSP/RTP(UDP) unicast streaming of image 2. *1 *2
RTSPUcAudioPort	Set Inq	57000 1024 to 65534	Sets the port to use for RTSP/RTP(UDP) unicast streaming of Audio. *1 *2

\*1: The reserved port cannot be used or used together with the other setting port. Refer to CGI command setting values (Reserved port).

\*2: Only even numbers can be assigned. The odd number with 1 added to the specified number is used for the RTCP port.

### subscribe.cgi

Setting (Set): command/subscribe.cgi?<Parameter>=<Value>

Parameter	Set Inq	Value	Description
inqjson	Set	-	Displays for Web App. Do not set this.
SubscriptionDuration	Set	-	Displays for Web App. Do not set this.

### status.cgi

Inquiry (Inq): command/inquiry.cgi?inq=status

Parameter	Set Inq	Value	Description
TemperatureWarning	Inq	1, 0	When a temperature anomaly occurs inside the camera, a notification is sent to the users who use the Web UI.  1 : Temperature anomaly status 0 : Normal status

### system.cgi

Inquiry (Inq): command/inquiry.cgi?inq=system

Parameter	Set Inq	Value	Description
ModelName	Inq	"SRG-A40" (SRG-A40) "SRG-A12" (SRG-A12)	Returns the camera name.
Serial	Inq	00000000 to 99999999	Returns the camera serial number.

## unsubscribe.cgi

Setting (Set): command/unsubscribe.cgi?<Parameter>=<Value>

Parameter	Set Inq	Value	Description
SubscriptionId	Set	-	Displays for Web App. Do not set this.

## imaging.cgi

Setting (Set): command/imaging.cgi?<Parameter>=<Value>

Inquiry (Inq): command/inquiry.cgi?inq=imaging

Parameter	Set Inq	Value	Description
AEspeed	Set Inq	<b>1</b> to 48	Sets the response speed of exposure. Camera operates according to this setting when ExposureMode is set to auto, shutter, or iris.  1 : About 1 sec. 48 : About 10 min.  * The time for response speed varies depending on the shutter speed.
AutoSlowShutterMode	Set Inq	on, <b>off</b>	Sets the Auto Slow shutter function to on or off.
BacklightCompensationMode	Set Inq	on, <b>off</b>	Sets the Backlight Compensation function to on or off. The Backlight Compensation function operates when ExposureMode is set to auto, shutter, or iris.
ChromaSuppressLevel	Set Inq	<b>1</b> 0 to 3	Sets suppression level of the color density when low lighting. Larger the number, greater the effect.
Defog	Set Inq	[Value1] on, <b>off</b>  [Value2] <b>0</b> to 3	Sets the Defog function to on or off. Defog=Value1,Value2  [Value1]  [Value2] 0 : Middle effect 1 : Weak effect 2 : Middle effect 3 : Maximum effect
DetailBandWidth	Set Inq	<b>standard</b> , low, mid, high, wide	Sets the bandwidth for signals undergoing contour emphasis. Setting is applied when DetailMode is set to Manual.  standard : Standard low : Low mid : Middle high : High wide : Wide
DetailBWBalance	Set Inq	<b>2</b> 0 to 4	Sets the balance between contours in black on the low brightness side of the spectrum and contours in white on the high brightness side. Smaller the number, larger the black contour ratio. Larger the number, larger the white contour ratio. * Setting is applied when DetailMode is set to manual.

Parameter	Set Inq	Value	Description
DetailCrispening	Set Inq	<b>3</b> 0 to 7	Sets the Crispening function of contour emphasis. Setting is applied when DetailMode is set to manual.
DetailHighlightDetail	Set Inq	<b>0</b> to 4	Sets the level of contour added to brightly-lit objects. Larger the number, larger the emphasis volume of the contour. Setting is applied when DetailMode is set to manual.
DetailHVBalance	Set Inq	<b>7</b> 5 to 9	Sets the ratio for horizontal and vertical contour correction signal elements. Setting is applied when DetailMode is set to manual. Smaller the number, larger the vertical contour correction. Larger the number, larger the horizontal contour correction.
DetailLevel	Set Inq	<b>7</b> 0 to 15	Sets the levels for contour emphasis.  0 : Small contour emphasis 15: Large contour emphasis
DetailLimit	Set Inq	<b>3</b> 0 to 7	Sets the maximum value for the amount of contour emphasis in black on the low brightness side of the spectrum and in white on the high brightness side. Setting is applied when DetailMode is set to manual.  0 : The maximum value of emphasis is limited lower 7 : The maximum value of emphasis is unlimited
DetailMode	Set Inq	<b>auto</b> , manual	Sets the contour emphasis.  auto : Sets the contour emphasis automatically manual: Sets the contour emphasis by setting DetailBandWidth, DetailBWBalance, DetailCrispening, DetailHighlightDetail, or DetailHVBalance
DetailSuperLow	Set Inq	<b>3</b> 0 to 7	Sets contour emphasis level of the super low range of the image. Setting is applied when DetailMode is set to manual.  0 : The amount of contour emphasis becomes lower 7 : The amount of contour emphasis becomes higher
ExposureCompensation	Set Inq	<b>7</b> 0 to 14	Sets the target brightness level of the exposure when ExposureMode is set to auto, shutter, or iris.  * Refer to the item "EXPOSURE COMPENSATION" of CGI Command Setting Values.

Parameter	Set Inq	Value	Description
ExposureExposureTime	Set Inq	The available values depend on the video output format.  <b>18</b> 6 to 33 (59.94p, 59.94i, 50p, 50i, 23.98p)  <b>16</b> 6 to 33 (29.97p, 29.97i, 25p, 25i)	Sets the shutter speed when ExposureMode is set to shutter or manual.  * Refer to the item "SHUTTER" of CGI Command Setting Values.
ExposureGain	Set Inq	The available values depend on the setting of the high sensitivity mode.  <b>1</b> to 13 (The high sensitivity mode is off.) <b>1</b> to 17 (The high sensitivity mode is on.)	Sets the gain value when ExposureMode is set to manual.  * Refer to the item "GAIN" of CGI Command Setting Values.
ExposureGainPoint	Set Inq	The available values depend on the setting of the high sensitivity mode.  <b>1</b> to 13 (The high sensitivity mode is off.) <b>1</b> to 17 (The high sensitivity mode is on.)	Sets the GainPoint position.  * The value can be set to ExposureMaxGain and under. * Refer to the item "GAIN" of CGI Command Setting Values.
ExposureGainPointEnable	Set Inq	on, <b>off</b>	Sets GainPoint function to on or off.
ExposureIris	Set Inq	0 to <b>25</b>	Sets iris while ExposureMode is set to iris or manual.  * Refer to the item "IRIS" of CGI Command Setting Values.
ExposureMaxExposureTime	Set Inq	The available values depend on the video output format.  <b>29</b> 16 to 33 (59.94p, 59.94i, 29.97p, 50p, 50i, 25p)  <b>30</b> 15 to 33 (23.98p)	Sets the limit for slow shutter speed when ExposureMode is set to auto or iris.  * Larger the number, faster the shutter speed. * Refer to the item "SHUTTER" of CGI Command Setting Values.
ExposureMaxGain	Set Inq	4 to <b>13</b>	Sets the maximum gain value automatically adjusted when ExposureMode is set to auto, shutter, or iris.  * Refer to the item "AUTO GAIN MAX. VALUE" of CGI Command Setting Values.
ExposureMinExposureTime	Set Inq	The available values depend on the video output format.  <b>18</b> 6 to 33 (59.94p, 59.94i, 50p, 50i, 23.98p)  <b>16</b> 6 to 33 (29.97p, 25p)	Sets the limit for fast shutter speed when ExposureMode is set to auto or iris.  * Larger the number, faster the shutter speed. * Refer to the item "SHUTTER" of CGI Command Setting Values.

Parameter	Set Inq	Value	Description
ExposureMode	Set Inq	<b>auto</b> , shutter, iris, manual	Sets the exposure control mode.  auto : Automatically adjust iris, gain, and shutter speed. shutter : Automatically adjust gain and iris according to set shutter speed. iris : Automatically adjust gain and shutter speed according to set iris. manual: Sets iris, gain, and shutter speed independently.
FlickerReduction	Set Inq	on, <b>off</b>	Sets the Flicker cancel function to on or off.
HighResolutionMode	Set Inq	on, <b>off</b>	Sets the high resolution mode to on or off. Setting this to on emphasizes the edge of the image. * When DetailMode is set to manual, the function is disabled.
HighSensitivityMode	Set Inq	on, <b>off</b>	Sets the high sensitivity mode to on or off.
LowLightBasisBrightness	Set Inq	<b>on</b> , off	Sets the AE Ref Low Light Basis Brightness function to on or off.
LowLightBasisBrightnessLevel	Set Inq	<b>7</b> 4 to 10	Sets the adjustment level of the AE Ref Low Light Basis Brightness function.  4 : Level -3 7 : Level 0 10 : Level +3
NoiseReduction	Set Inq	<b>3</b> 0 to 5	Sets the strength level for Noise Reduction. When NoiseReductionMode is set to simple, the setting is applied.
NoiseReduction2DLevel	Set Inq	<b>3</b> 0 to 5	Sets 2D NR. Setting is applied when NoiseReductionMode is set to advanced.
NoiseReduction3DLevel	Set Inq	<b>3</b> 0 to 5	Sets 3D NR. Setting is applied when NoiseReductionMode is set to advanced.
NoiseReductionMode	Set Inq	<b>simple</b> , advanced	Sets the Noise Reduction function operation mode.  simple : Adjusts 2D NR and 3D NR simultaneously advanced : Adjusts each 2D NR and 3D NR
SpotlightCompensationMode	Set Inq	on, <b>off</b>	Sets the Spotlight compensation function to on or off. The Spotlight Compensation function operates when ExposureMode is set to auto, shutter, or iris. * When BacklightCompensationMode is on, this is disabled.
Stabilizer	Set Inq	on, <b>off</b>	Sets the image stabilization function to on or off.
VisibilityEnhancer	Set Inq	on, <b>off</b>	Sets the Visibility Enhancer function to on or off.

Parameter	Set Inq	Value	Description
VisibilityEnhancerLevel	Set Inq	[Value1] <b>3</b> 0 to 6 [Value2] <b>2</b> 0 to 3 [Value3] <b>1</b> 0 to 2	Sets the parameter for Visibility Enhancer function.  VisibilityEnhancerLevel=Value1,Value2, Value3  [Value1] Brightness level  [Value2] Brightness correction  [Value3] Strength correction
WhiteBalanceCbGain	Set Inq	<b>128</b> 0 to 255	Sets the B gain when WhiteBalanceMode is set to manual.
WhiteBalanceCrGain	Set Inq	<b>128</b> 0 to 255	Sets the R gain when WhiteBalanceMode is set to manual.
WhiteBalanceMode	Set Inq	<b>auto</b> , indoor, outdoor, onepushwb, atw, manual	Sets the White Balance mode.  auto : Automatically adjusts the color to be closest to the image you are viewing (approx. 2500K to 7500K). indoor : Adjusts the white balance for shooting indoors (approx. 3200K). outdoor : Adjusts the white balance for shooting outdoors (approx. 5800K). onepushwb : Adjust the white balance when the white balance one push trigger command is received. Keep the white balance after adjusting. atw : Adjusts the white balance automatically to reproduce original colors of the objects while eliminating the influences caused by environmental illumination or lights. manual : Adjusts the white balance by specifying R gain (WhiteBalanceCrGain) and B gain (WhiteBalanceCbGain).
WhiteBalanceOffset	Set Inq	<b>7</b> 0 to 14	Sets the adjustment value for the white convergence point of White balance. The lower the value of WhiteBalanceOffset it is shifted toward blue, and the higher the value it is shifted toward red. WhiteBalanceOffset is applied when WhiteBalanceMode is set to auto, atw, or manual.
WhiteBalanceOnePushTrg	Set	on	Start adjusting the white balance when WhiteBalanceMode is set to onepushwb.
WhiteBalanceSpeed	Set Inq	<b>3</b> 1 to 5	Sets the speed at which the camera reaches the white convergence point of White balance when WhiteBalanceMode is set to auto or atw.  * Larger the number, faster.
PictureEffect	Set Inq	<b>off</b> , bw	Sets whether to output the image as a 2 color video of black and white or not.  off : Normal bw : Outputs the image in black and white.

## ptzf.cgi

Setting (Set): command/ptzf.cgi?<Parameter>=<Value>

Inquiry (Inq): command/inquiry.cgi?inq=ptzf

Parameter	Set Inq	Value	Description
AbsolutePanTilt	Set	<p>[Value1] de00 to 2200</p> <p>[Value2] The available values depend on the Eflip settings. fc00 to 1200 (Off) ee00 to 0400 (On)</p> <p>[Value3] 1 to 24</p>	<p>Executes the pan/tilt movement by specifying coordinate. AbsolutePanTilt=Value1,Value2,Value3</p> <p>[Value1] Sets the pan position by coordinate</p> <p>de00 : Counterclockwise 170 deg. 0000 : Home Position 2200 : Clockwise 170 deg.</p> <p>[Value2] Sets the tilt position by coordinate</p> <p>When Eflip is set to off fc00 : -20 deg. to the lower direction 0000 : Home Position 1200 : +90 deg. to the upper direction When Eflip is set to on ee00 : -90 deg. to the lower direction 0000 : Home Position 0400 : +20 deg. to the upper direction</p> <p>* Refer to the item "PAN/TILT POSITION" of CGI Command Setting Values.</p> <p>[Value3] Sets the movement speed</p> <p>* Larger the number, faster. * Refer to the item "PAN/TILT POSITION" of CGI Command Setting Values.</p>

Parameter	Set Inq	Value	Description
AbsolutePTZF	Set Inq	<p>[Value1] de00 to 2200</p> <p>[Value2] The available values depend on the Eflip settings. fc00 to 1200 (Off) ee00 to 0400 (On)</p> <p>[Value3] The available values depend on the Zoom Mode status and the video size of the output signal format. 0000 to 4000 (optical) 0000 to 5556 (clearimage, 4K) 0000 to 6000 (clearimage, except 4K) 0000 to 7ac0 (full)</p> <p>[Value4] 0000 to f000</p>	<p>Executes the pan/tilt/zoom/focus movement by specifying coordinate, or returns the current coordinate. AbsolutePTZF=Value1,Value2,Value3,Value4</p> <p>[Value1] Sets the pan position by coordinate</p> <p>de00 : Counterclockwise 170 deg. 0000 : Home Position 2200 : Clockwise 170 deg.</p> <p>* Refer to the item "PAN/TILT POSITION" of CGI Command Setting Values.</p> <p>[Value2] Sets the tilt position by coordinate</p> <p>When Eflip is set to off fc00 : -20 deg. to the lower direction 0000 : Home Position 1200 : +90 deg. to the upper direction When Eflip is set to on ee00 : -90 deg. to the lower direction 0000 : Home Position 0400 : +20 deg. to the upper direction</p> <p>* Refer to the item "PAN/TILT POSITION" of CGI Command Setting Values.</p> <p>[Value3] Sets the zoom position by coordinate 0000 : Wide end 4000 : Optical tele end 5556 : Clear Image Zoom tele end *1 (4K) 6000 : Clear Image Zoom tele end *1 (except 4K) 7ac0 : Digital Zoom tele end *1</p> <p>* Refer to the item "ZOOM POSITION" of CGI Command Setting Values.</p> <p>* 1 Clear Image Zoom function and digital zoom function are not available for SRG-A12.</p> <p>[Value4] Sets the focus position by coordinate</p> <p>0000 : Near end f000 : Far end</p> <p>* Refer to the item "FOCUS" of CGI Command Setting Values.</p>

Parameter	Set Inq	Value	Description
AbsoluteZoom	Set	The available values depend on the Zoom Mode status and the video size of the output signal format.  0000 to 4000 (optical) 0000 to 5556 (clearimage, 4K) 0000 to 6000 (clearimage, except 4K) 0000 to 7ac0 (full)	Moves the zoom by specifying the absolute position.  0000 : Wide end 4000 : Optical tele end 5556 : Clear Image Zoom tele end *1 (4K) 6000 : Clear Image Zoom tele end *1 (except 4K) 7ac0 : Digital Zoom tele end *1  * Refer to the item "ZOOM POSITION" of CGI Command Setting Values.  * 1 Clear Image Zoom function and digital zoom function are not available for SRG-A12.
AFInterval	Set Inq	[Value1] 0 to 5 to 255  [Value2] 0 to 5 to 255	Sets the operation time and the stop time when AFMode is set to interval or zoomtrigger. (unit: second)  AFInterval=Value1,Value2  [Value1] Operation time * When setting to 0, Focus is fixed.  [Value2] Stop time * When setting to 0, Focus is fixed.
AFMode	Set Inq	<b>normal</b> , interval, zoomtrigger	Sets the auto focus mode.  normal : Always adjusts the focus automatically. interval : Adjust the focus automatically with the specified operation time and stop time. zoomtrigger : When changing the zoom position, adjust the focus automatically only for the specified operation interval.
AFSensitivity	Set Inq	<b>normal</b> , low	Sets the auto focus sensitivity.  normal : Speeds up the focus follow speed. low : Improves the focus stability.
Cancel	Set	on	Cancels the running PTZ command.  Cancel=on
FocusMode	Set Inq	<b>auto</b> , manual	Sets the focus control.  auto : Automatic adjustment by the camera. manual : Manual adjustment by the user.
FocusNearLimit	Set Inq	1000 to <b>b000</b> to f000	Sets the limit position of the Near side focus.  * Refer to the item of the CGI command setting value (FOCUS).

Parameter	Set Inq	Value	Description
Move	Set	[Value1] left, right, up, down, up-left, up-right, down-left, down-right  [Value2] 0 to 24	Moves Pan-Tilt by specifying direction.  Move=Value1,Value2  [Value1] Sets the direction  left : Left right : Right up : Up down : Down up-left : Up left up-right : Up right down-left : Down left down-right: Down right  [Value2] Sets the speed for Pan-Tilt  * Larger the number, faster. When set to 0, the speed changes depending on the zoom position. * Refer to the item "PAN/TILT SPEED" of CGI Command Setting Values.
Move	Set	[Value1] tele, wide  [Value2] 0 to 8	Moves Zoom by specifying direction.  [Value1] Sets the direction  tele : Tele wide : Wide  [Value2] Sets the speed  * Larger the number, faster.
Move	Set	[Value1] near, far, onepushaf  [Value2] 0 to 8	Moves Focus by specifying direction.  [Value1] Sets the direction  near : Near far : Far onepushaf : Perform one push auto focus.  [Value2] Sets the speed  * Larger the number, faster. * The speed of performing onepushaf is same at all values.
Move	Set	[Value1] stop  [Value2] pantilt, motor, zoom, focus	Stops the moving for Pan, Tilt, Zoom, and Focus.  [Value1] Stops  [Value2] pantilt : Stops Pan-Tilt moving motor : Stops Pan-Tilt moving zoom : Stops Zoom moving focus : Stops Focus moving
OpticalZoomMaxMagnification	Inq	X20 (SRG-A40)  X12 (SRG-A12)	Returns the maximum optical zoom ratio.

Parameter	Set Inq	Value	Description
PanLimitMode	Set Inq	<b>unlimited</b> , limited	Sets the limit mode of the pan's movement range.  unlimited : A limit does not exist. limited : Limits in the range which is set on PanLimit.
PanMovementRange	Inq	[Value1] de00  [Value2] 2200	Returns the possible movement range of pan. PanMovementRange=Value1,Value2  [Value1] de00 : (Left end)  [Value2] 2200 : (Right end)  * Refer to the item "PAN/TILT POSITION" of CGI Command Setting Values.
PanTiltMaxVelocity	Inq	24	Returns the maximum speed of Pan/Tilt movement.
PanTiltReset	Set	on	Resets the Pan-Tilt position for the camera to recognize the position correctly and to control Pan-Tilt.
PtzfStatus	Inq	[Value1] idle, moving, unknown  [Value2] idle, moving, unknown  [Value3] idle, moving, unknown  [Value4] idle, moving, unknown	Returns the current status of pan / tilt / zoom / focus movement.  PtzfStatus=Value1,Value2,Value3,Value4  [Value1] Returns the current status of pan.  idle : Idle moving : Moving unknown : Abnormal status  [Value2] Returns the current status of tilt.  idle : Idle moving : Moving unknown : Abnormal status  [Value3] Returns the current status of zoom.  idle : Idle moving : Moving unknown : Abnormal status  [Value4] Returns the current status of Focus.  idle : Idle moving : Moving unknown : Abnormal status
RampCurve	Set Inq	<b>1</b>	Sets the pan/tilt's acceleration and deceleration curve.

Parameter	Set Inq	Value	Description
RelativeFocus	Set	ffff1000 to 0000f000	Moves the focus position by specifying relative position from the current position. This command is only valid when FocusMode is set to manual. Actual movement range is also affected by the value of FocusNearLimit parameter.  ffff1000 : The maximum amount to focus far direction 0000f000 : The maximum amount to focus near direction  * Refer to the item "FOCUS" of CGI Command Setting Values.
RelativePanTilt	Set	[Value1] bc00 to 4400  [Value2] ea00 to 1600  [Value3] 1 to 24	Moves pan/tilt by specifying relative coordinate from the current position.  RelativePanTilt=Value1,Value2,Value3  [Value1] Sets the pan coordinate  [Value2] Sets the tilt coordinate  * Refer to the item "PAN/TILT POSITION" of CGI Command Setting Values.  [Value3] Sets the speed  * Refer to the item "PAN/TILT SPEED" of CGI Command Setting Values.
RelativeZoom	Set	The available values depend on the Zoom Mode status and the video size of the output signal format.  ffffc000 to 00004000 (optical) ffffa000 to 00005556 (clearimage, 4K) ffffa000 to 00006000 (clearimage, except 4K) ffff8540 to 00007ac0 (full)	Moves the zoom position by specifying relative position from the current position.  ffffc000 to 00004000 : Optical zoom Range ffffa000 to 00005556 : Clear Image Zoom Range *1 (4K) ffffa000 to 00006000 : Clear Image Zoom Range *1 (except 4K) ffff8540 to 00007ac0 : Digital zoom Range *1  * Refer to the item "ZOOM POSITION" of CGI Command Setting Values.  *1 Clear Image Zoom function and digital zoom function are not available for SRG-A12.
SlowPanTiltMode	Set Inq	on, off	Sets the slow speed mode of pan/tilt to on or off.  on : Slow speed mode off : Normal mode
TeleConvertMode	Set Inq	on, off	Sets the teleconvert function to on or off.
TiltLimitMode	Set Inq	unlimited, limited	Sets the limit mode of the tilt's movement range.  unlimited : Limit does not exist. limited : Limits in the range which is set on TiltLimit.

Parameter	Set Inq	Value	Description
TiltMovementRange	Inq	[Value1] Depends on the Eflip settings. fc00 (Off) ee00 (On)  [Value2] Depends on the Eflip settings. 1200 (Off) 0400 (On)	Returns the coordinate of the possible movement range of tilt. TiltMovementRange=Value1,Value2  [Value1] Lower end  [Value2] Upper end  * Refer to the item "PAN/TILT POSITION" of CGI Command Setting Values.
ZoomMaxVelocity	Inq	8	Returns the maximum speed of zoom movement.
ZoomMovementRange	Inq	SRG-A40  [Value1] 0000  [Value2] 4000  [Value3] 5556 (4K) 6000 (except 4K)  [Value4] 7ac0  SRG-A12  [Value1] 0000  [Value2] 4000  [Value3] 4000  [Value4] 4000	Returns the possible movement range of zoom.  ZoomMovementRange=Value1,Value2, Value3,Value4  [Value1] Wide end  [Value2] Optical Zoom Tele end  [Value3] Clear Image Zoom Tele end  [Value4] Digital Zoom Tele end  * Refer to the item "ZOOM POSITION" of CGI Command Setting Values.
ZoomMode	Set Inq	<b>optical</b> , clearimage, full	Sets the operation range of the zoom function.  optical : Optical zoom clearimage : Optical and Clear Image Zoom *1 full : Optical, Clear Image Zoom *1, and Digital zoom. *1  *1 Clear Image Zoom function and Digital zoom function are not available for SRG- A12.

Parameter	Set Inq	Value	Description
ZoomMove	Set	[Value1] tele, wide, stop  [Value2] 0 to 32766	The command for operating with the Zoom slider of the Web UI.  [Value1] Direction  [Value2] Speed  The speed range is 0 to 32766. However, the operation is divided into 8 steps.  0 to 4095 : 0 (slow) 4096 to 8191 : 1 8192 to 12287 : 2 12288 to 16383 : 3 16384 to 20479 : 4 20480 to 24575 : 5 24576 to 28671 : 6 28672 to 32766 : 7 (fast)
ZoomSpeedScale	Set Inq	10 to <b>100</b>	Sets the coefficient for the operation amounts by the Zoom slider of the Web UI.  10 (slow) to 100 (fast)
AbsoluteFocus	Set Inq	<b>1000</b> 0000 to f000	Adjust the focus using the absolute value.
PanTiltMove	Set	[Value1] left, right, up, down, up- left, up-right, down-left, down-right, stop  [Value2] 0 to 24  [Value3] 0 to 23	Performs the direction drive of the camera's Pan-Tilt.  Specifies the speed of Pan, Tilt to the specified direction.  [Value1] Direction  [Value2] Pan speed  [Value3] Tilt speed
PanTiltSpeedScale	Set Inq	<b>25</b> 10 to 100	Sets the coefficient for the operation amounts by the joystick operation of the Web UI.  10 (slow) to 100 (fast)

## presetposition.cgi

Setting (Set): command/presetposition.cgi?<Parameter>=<Value>

Inquiry (Inq): command/inquiry.cgi?inq=presetposition

Parameter	Set Inq	Value	Description
CallMode	Set Inq	freeze, <b>normal</b>	Sets the video output during preset recalling.  freeze : Outputs frozen images during running the recalling. (Pict Freeze Preset function) normal : Does not freeze the camera images during recalling.
CommonSpeed	Set Inq	1 to <b>25</b>	Sets the pan/tilt speed when SpeedSelect is set to Common.  * Refer to the item "PRESET RUN SPEED" of CGI Command Setting Values.

Parameter	Set Inq	Value	Description
HomePos	Set	recall	Moves the Pan-Tilt of the camera to the Home Position.  * Coordinate of the home position is Pan : 0000, Tilt : 0000. This coordinate cannot be changed.
PresetCall	Set	[Value1] 1 to 256	Recalls a registered preset.  PresetCall=Value1  [Value1] The preset number to recall  * Refer to the item "PRESET RUN SPEED" of CGI Command Setting Values. * Larger the number, faster.
PresetClear	Set	1 to 256	Clears the preset corresponding to the specified number.
PresetImagingSet	Set	1	Registers the parameter setting which belongs to imaging.cgi to Preset 1.
PresetName	Set Inq	[Value1] 1 to 256  [Value2] 0 to 32 characters	Sets the name of registered preset. Specifies one of the registered preset number on setting. PresetName=Value1,Value2 Returns all the registered preset name to the inquiry. PresetName=Value11,Value21[,Value12, Value22, ...]  [Value1n] Preset number  [Value2n] Preset name The 32 and less alphanumeric characters can be set.
PresetNum	Inq	256	Returns the maximum number of preset that can be registered.
PresetSet	Set	[Value1] 1 to 256  [Value2] 0 to 32 characters  [Value3] on, off	Registers the current pan/tilt/focus/zoom position and camera settings as a preset position.  PresetSet=Value1,Value2,Value3  [Value1] Preset number to register  [Value2] Name Preset name to register The 32 and less alphanumeric characters can be set.  [Value3] Thumbnail Sets whether to use the current camera image as a thumbnail on : Use off : Not use
PresetThumbnailClear	Set	1 to 256	Deletes the thumbnail of a registered preset.

Parameter	Set Inq	Value	Description
SeparateSpeed	Set Inq	[Value1] 1 to 256  [Value2] 1 to 25	Sets the pan/tilt speed corresponding to each preset when SpeedSelect is set to separate.  [Value1] Preset number to be set  [Value2] Speed to be set  * Refer to the item "PRESET RUN SPEED" of CGI Command Setting Values.
SpeedSelect	Set Inq	separate, <b>common</b>	Sets the pan/tilt speed during recalling the preset.  separate : Uses the speed set for each preset number with the SeparateSpeed command  common : Uses the common speed for all preset numbers set with the CommonSpeed command

### put\_presetimg.cgi

Save the Thumbnail of the specified preset number.

- The camera accepts the following image.
  - Format: JPEG, PNG
  - Size: 64×36 to 1920×1080 Pixel (Width × Height)

<Syntax>

http://<camera\_address>/command/put\_presetimg.cgi  
form-data; name="presetimg<No.>"

- <No.>: Preset number

### /preset/presetimg<No.>.jpg

Get the Thumbnail of the specified preset number.

<Syntax>

http://<camera\_address>/preset/presetimg<No.>.jpg

- <No.>: Preset number

### tally.cgi

Setting (Set): command/tally.cgi?<Parameter>=<Value>

Inquiry (Inq): command/inquiry.cgi?inq=tally

Parameter	Set Inq	Value	Description
TallyControl	Set Inq	on, <b>off</b>	Sets the Tally Lamp to on or off.  on : Turns on off : Turns off
TallyLevel	Set Inq	off, <b>low</b> , high	Sets the lighting level for the Tally Lamp.  off : Always turned off regardless of TallyControl on or off setting. low : Dark high: Bright

Parameter	Set Inq	Value	Description
RTallyStatus	Inq	0, 1	Outputs Tally Control status. 0 : Turns off the light. 1 : Turns on the light.
TallyIndicationPtzAutoFraming	Set Inq	on, off	Sets the Green Tally movement while tracking PTZ Auto Framing. on : Controls the Tally lamp depending on the Analytics status. off : Does not control the Tally lamp depending on the Analytics status.

## ircf.cgi

Setting (Set): command/ircf.cgi?<Parameter>=<Value>

Inquiry (Inq): command/inquiry.cgi?inq=ircf

Parameter	Set Inq	Value	Description
IrCutFilterLevel	Set Inq	<b>14</b> 0 to 255	Sets the threshold value for the change from the night mode to the day mode when IrCutFilterMode is set to auto.  * Smaller the number, more switchable from the night mode to the day mode. * This might not switch to the day mode even the target is blight, in case the value here is big. In this case, use the camera by setting the value smaller.
IrCutFilterManual	Set Inq	on, <b>off</b>	Sets Day/Night mode. When IrCutFilterMode is set to auto, IrCutFilterManual cannot set to on.  on : Night mode off : Day mode
IrCutFilterMode	Set Inq	<b>manual</b> , auto	Sets whether to change the day/night mode automatically or not.  manual: Sets the mode by IrCutFilterManual auto : Sets the mode automatically
IrCutFilterStatus	Inq	night, day	Returns the status of Day/Night mode.  night : The camera is in Night mode. day : The camera is in Day mode.
NearIRFocusCorrection	Set Inq	on, <b>off</b>	Sets whether to enable/disable focus correction when used under IR (near infrared) light.  on : Enable correction off : Disable correction

## sysinfo.cgi

Setting (Set): command/sysinfo.cgi?<Parameter>=<Value>

Inquiry (Inq): command/inquiry.cgi?inq=sysinfo

Parameter	Set Inq	Value	Description
AudiInFunc	Inq	1	Returns whether the audio input function is supported or not.  1 : Supported
ContinuousPanTiltZoomFunc	Inq	0	Returns whether ContinuousPanTiltZoom CGI command is supported or not.  0 : Not supported
ContinuousPanTiltZoomInterval	Inq	" "	No value for this model, as it does not support ContinuousPanTiltZoom function.  " " : no value
DefogFunc	Inq	1	Returns whether the Defog function is supported or not.  1 : Supported
DiagDataDownloadFunc	Inq	1	Returns whether the function of the analysis data download is supported or not.  1 : Supported
EflipFunc	Inq	1	Returns whether the picture inversion function is supported or not.  1 : Supported
EncryptionCapability	Inq	1	Returns whether the HTTPS function is supported or not.  1 : Supported
HdmiOutFunc	Inq	1	Returns whether the HDMI output is supported or not.  1 : Supported
HPoEFunc	Inq	1	Returns whether PoE++ (IEEE802.3bt) is supported or not.  1 : Supported
IrCutFilterFunc	Inq	1	Returns whether the Day/Night function is supported or not.  1 : Supported
IrCutFilterTimeFunc	Inq	0	Returns whether the function to specify the time to switch is supported or not, when you switch day/night mode automatically.  0 : Not supported
MicLineSelectFunc	Inq	1	Returns whether the function to switch the audio input level is supported or not.  1 : Supported
PanTiltFunc	Inq	1	Returns whether the Pan/Tilt function is supported or not.  1 : Supported
PasswordChanged	Inq	0, 1	Returns whether the admin password has been changed or not.  0 : Not changed 1 : Changed

Parameter	Set Inq	Value	Description
Power	Inq	on, standby	Returns the status of the camera power.  on : Starting status standby : Standby status
PtzTraceFunc	Inq	0	Returns whether the PTZ trace function is supported or not.  0: Not supported
QfhdFunc	Inq	1	Returns whether to support 4K in video output format setting.  1 : Supported
S700pFunc	Inq	0	Returns whether the S700PTP protocol is supported or not.  0 : Not supported
Serial	Inq	00000000 to 99999999	Returns the serial number of the camera.
SoftVersion	Inq	0 to 32 characters	Returns the software version.
SuperImposeFunc	Inq	0	Returns whether the superimpose function is supported or not.  0 : Not supported
TallyLampFunc	Inq	1	Returns whether Tally Lamp is available or not.  1 : Available
TeleConvertFunc	Inq	1	Returns whether the teleconversion function is supported or not.  1 : Supported
ThumbnailFunc	Inq	0	Returns whether thumbnail of the Preset function is supported or not.  0 : Not supported
WhiteBalanceOffsetFunc	Inq	0	Returns whether setting for the offset value of White Balance B gain and R gain can be individually changed or not.  0 : Not supported
WideDynamicRangeLevelFunc	Inq	0	Returns whether the Wide Dynamic Range function (View-DR) is supported or not.  0 : Not supported
WideDynamicRangeLevelList	Inq	" "	No value for this model, as it does not support WideDynamicRangeLevel function.  " " : no value
NetworkCameraName	Inq	[Fixed value] SRG-A40 : A40 SRG-A12 : A12	Returns the camera name.  NetworkCameraName can only be inquired. Can be changed in CameraName of network.cgi.
FreeDFunc	Inq	0	Returns the presence/absence of the Free-D (Tracking data output) correspondence.  0 : Does not correspond.
VersionupStatus	Inq	-	For display of Web App.
VersionupProgress	Inq	-	For display of Web App.

## main.cgi

Setting (Set): command/main.cgi?<Parameter>=<Value>

Parameter	Set Inq	Value	Description
FactoryDefault	Set	hard, soft	Resets the camera to the default settings.  hard: Hard reset (returns all settings to the factory default) soft: Soft reset (retain the network and security settings)
System	Set	on, reboot, standby	Sets the camera power status.  on : Sets to the starting status. reboot : Reboots the camera. standby: Sets to the standby status.  * The status can be acquired on "Power" of system.cgi.

## logconfig.cgi

Setting (Set): command/logconfig.cgi?<Parameter>=<Value>

Inquiry (Inq): command/inquiry.cgi?inq=logconfig

Parameter	Set Inq	Value	Description
AccessLogLevel	Set Inq	info, warning, critical	Setting of the log level of the access log.  info : Saves all logs of abnormal levels. warning : Saves logs of critical and warning levels. critical : Saves only logs of critical level.
AccessLogSize	Set Inq	200 to <b>1024</b>	Setting of the maximum log size of the access log. (Unit: line)
EnableDiagDataDownload	Set Inq	on, <b>off</b>	Sets whether the analysis data is allowed to download or not.  on : Allowed off : Not allowed
SystemLogLevel	Set Inq	info, warning, critical	Setting of the log level of the system log.  info : Saves all logs of abnormal levels. warning : Saves logs of critical and warning levels. critical : Saves only logs of critical level.
SystemLogSize	Set Inq	200 to <b>1024</b>	Setting of the maximum log size of the system log. (Unit: line)

## user.cgi

Setting (Set): command/user.cgi?<Parameter>=<Value>

Inquiry (Inq): command/inquiry.cgi?inq=user

<n> of the parameter tail is the number between 1 to 9.

Parameter	Set Inq	Value	Description
AdminInfo	Inq	admin	Returns the administrator name.
Administrator	Set	-	Use from Admin menu. Do not use directly.

Parameter	Set Inq	Value	Description
DigestAuthNonceDuration	Set Inq	<b>300</b> 1 to 3600	Setting of the effective duration of the Nonce value in Digest Access Authentication. (Unit: second)
User<n>	Set	-	Use from Admin menu. Do not use directly.
UserInfo<n>	Inq	-	Returns user name.
UserNum	Inq	9	Returns the maximum number of registrable users.

## viewermode.cgi

Inquiry (Inq): command/inquiry.cgi?inq=viewermode

Parameter	Set Inq	Value	Description
ViewerMode	Inq	0000083f, 00000fff, ffffff	Returns the access authority of the users accessing to the camera.  0000083f : Light (when accessed via Web browser, the image can be displayed on the viewer screen.) 00000fff : Full (when accessed via Web browser, viewer screen except for the power can be operated.) ffffff : Administrator (when accessed via Web browser, all the functions of this camera including the camera setting can be used.)  * For details, refer to "Administrator and User" of "Operating Instructions."

## network.cgi

Setting (Set): command/network.cgi?<Parameter>=<Value>

Inquiry (Inq): command/inquiry.cgi?inq=network

Parameter	Set Inq	Value	Description
Autolpv6	Set Inq	<b>on, off</b>	Setting whether acquires the IPv6 IP address automatically or not.  on : Acquires automatically off : Does not acquire automatically
CameraName	Set Inq	0 to 8 characters [Default] SRG-A40 : A40 SRG-A12 : A12	Setting of the camera name. The 8 and less alphanumerical characters can be set.
CurrentGateway	Inq	IPv4 address	Returns the current IPv4 address of the default gateway.
CurrentGatewayv6	Inq	IPv6 address	Returns the current address of the IPv6 default gateway.
CurrentIp	Inq	IPv4 address	Returns the current IPv4 address.
CurrentIpv6Address1	Inq	IPv6 address	Returns the current IPv6 address1.
CurrentIpv6Address2	Inq	IPv6 address	Returns the current IPv6 address2.
CurrentPrefix1	Inq	0 to 128	Returns the current IPv6 prefix value.
CurrentPrefix2	Inq	0 to 128	Returns the current IPv6 prefix2 value.

Parameter	Set Inq	Value	Description
CurrentPrimaryDns	Inq	IPv4 or IPv6 address	Returns the current IP address of the primary DNS server.
CurrentSecondaryDns	Inq	IPv4 or IPv6 address	Returns the current IP address of the secondary DNS server.
CurrentSubnetmask	Inq	IPv4 address	Returns the current IPv4 subnet mask.
Dhcp	Set Inq	<b>on, off</b>	On/Off setting of DHCP client function.
DnsAuto	Set Inq	<b>on, off</b>	Setting to enable/disable the function that the IP address of DNS server is acquired from the DHCP server. This setting is common for IPv4 and IPv6.  on : Enable off : Disable
Gateway	Set Inq	IPv4 address	Setting of the IPv4 address of the default Gateway.
Gatewayv6	Set Inq	IPv6 address	Setting of the address of IPv6 default Gateway.
HttpMaxKeepAliveIdle	Set Inq	<b>70</b> 0 to 7200	Setting of the time to terminate the session by judging as Idle. (Unit: second)  * When set to 0, the session is not terminated.
HttpPort	Set Inq	<b>80</b> , 1024 to 65534	Setting of the port number to use in HTTP protocol. This setting is common for IPv4 and IPv6.  * Reserved port cannot be used and overlapped with other setting ports. Refer to the item "RESERVED PORT" of CGI Command Setting Values.
Ip	Set Inq	IPv4 address	Setting of IPv4 address.
IPsetupSetEnable	Set Inq	<b>off, on</b>	Setting whether to accept the setting made by the RM-IP Setup Tool or not.  off : Does not accept on : Accepts  * Setting to off prevents the unintentional change by the RM-IP Setup Tool.
Ipv6	Set Inq	IPv6 address	Setting of IPv6 address.
LinkLocalIPv6	Inq	IPv6 address	Returns the link local IPv6 address.
MacAddress	Inq	-	Returns MAC Address of the camera.
PhyStat	Inq	10half, 10full, 100half, 100full, 1000half, 1000full	Returns the connection status of the Ethernet.  10half : 10Mbps, half-duplex communication 10full : 10Mbps, full-duplex communication 100half : 100Mbps, half-duplex communication 100full : 100Mbps, full-duplex communication 1000half : 1000Mbps, half-duplex communication 1000full : 1000Mbps, full-duplex communication
Prefix	Set Inq	<b>64</b> 1 to 128	Setting of the IPv6 prefix length value.

Parameter	Set Inq	Value	Description
PrimaryDns	Set Inq	IPv4 or IPv6 address	Setting of the static IP address of Primary DNS server.
SecondaryDns	Set Inq	IPv4 or IPv6 address	Setting of the static IP address of Secondary DNS server.
Subnetmask	Set Inq	IPv4 address	Setting of the IPv4 subnet mask.
Hostname	Inq	Device specific	Returns the camera Hostname.

## auth.cgi

Setting (Set): command/auth.cgi?<Parameter>=<Value>

Inquiry (Inq): command/inquiry.cgi?inq=auth

<n> of the parameter tail is the number between 1 to 10. Corresponds to the exception 1 to 10 of the Referer check which can be registered to the camera.

Parameter	Set Inq	Value	Description
BruteForceAttackCount	Set Inq	<b>8</b> 3 to 100	Setting of number of authentication failure to judge as brute-force attack.
BruteForceAttackProtection	Set Inq	<b>on, off</b>	On/Off setting of brute-force attack protection function.
BruteForceAttackReleaseMode	Set Inq	always, <b>timer</b>	Setting of condition to release brute-force attack judgment.  always : Does not release after judging as attack timer : After the judgment as attack, wait for the time period set on BruteForceAttackReleaseTimer, then release
BruteForceAttackReleaseTimer	Set Inq	<b>60</b> 30 to 86400	Setting of time period to release attacker judgment, when BruteForceAttackReleaseMode is set to "timer". (Unit: second)
RcExceptionHostname<n>	Set Inq	0 to 63 characters	Setting of exception host name or IP address which will be excluded from Referer check to register as number set in <n>.
RcExceptionNum	Inq	10	Returns the maximum number of registrable hosts that are not targeted for the Referrer check.
RcExceptionPort<n>	Set Inq	<b>80</b> 0 to 65535	Setting of exception port number which will be excluded from Referer check to register as number set in <n>.
RefererCheck	Set Inq	<b>on, off</b>	On/Off setting of Referer check function.

## filtering.cgi

Setting (Set): command/filtering.cgi?<Parameter>=<Value>

Inquiry (Inq): command/inquiry.cgi?inq=filtering

<n> of the parameter tail is the number between 1 to 3. Corresponds to the IPv4 filter 1 to 3 or IPv6 filter 1 to 3 which can be registered to the camera.

### Note

If you set V4FilterDefaultRule or V6FilterDefaultRule to reject with setting IP address to grant access unregistered, even the Admin cannot access with CGI command. In this case, revert to the default status using Reset switch on the Camera.

Parameter	Set Inq	Value	Description
DosDefenseRuleNum	Inq	3	Returns possible numbers for DoS Protection setting.
FragmentDeny	Set Inq	on, <b>off</b>	Setting whether the Fragment packet is denial or not.  on : Denies Fragment packet off : Does not deny Fragment packet
V4DosDefenseBurst<n>	Set Inq	<b>3</b> 2 to 600	Setting of consecutive access numbers to be judged as being attacked by IPv4 DoS attack protection function.
V4DosDefenseEnable<n>	Set Inq	on, <b>off</b>	On/Off Setting of IPv4 DoS attack protection function.
V4DosDefenseExpire<n>	Set Inq	<b>60</b> 1 to 86400	Setting of the predetermined time to discard the results judged as a DoS attack by IPv4 DoS attack protection function. (Unit: second)
V4DosDefenseLimit<n>	Set Inq	<b>5</b> 1 to 100	Setting of the possible request times per minute after limiting the upper limit of access with the IPv4 DoS attack protection function.
V4DosDefensePort<n>	Set Inq	<b>80</b> 0 to 65535	Setting of the port number to defend against requests with the IPv4 DoS attack protection function.
V4FilterDefaultRule	Set Inq	<b>allow, reject</b>	Setting of the basic policy for IPv4 IP Filter.  allow : All the other accesses whose settings are not specified by V4FilterRule parameter will be allowed. reject : All the other accesses whose settings are not specified by V4FilterRule parameter will be denied.
V4FilterFunc	Set Inq	on, <b>off</b>	On/Off setting of IPv4 IP Filter function.

Parameter	Set Inq	Value	Description
V4FilterRule	Set Inq	[Value1] <b>0</b> to 9  [Value2] IPv4 address  [Value3] <b>0</b> to 32  [Value4] <b>tcp, udp, icmp, all</b>  [Value5] <b>0</b> to 65535  [Value6] allow, reject	Setting of IPv4 Filter function rules. Up to 10 rules can be set.  V4FilterRule=Value11,Value21,Value31,Value41,Value51,Value61,Value12,Value22,Value32,Value42,Value52,Value62[,...,Value110,Value210,Value310,Value410,Value510,Value610]  [Value1] Setting of rule number Smaller value means higher priorities  [Value2] Setting of supported network address  [Value3] Setting of subnet mask value QoS supports (bit number from the left side of network address)  [Value4] Setting of supported protocol tcp : TCP udp : UDP icmp : ICMP In this case, port number (Value5) will be discarded, but it is still necessary. Filter will be applied for all ICMP messages. all : TCP, UDP, ICMP The port number (Value5) designation only works for TCP and UDP.  [Value5] Setting of supported port numbers When set to 0, all the Port numbers are supported.  [Value6] Setting of policy allow : Specified accesses to the camera will be allowed. reject : Specified accesses to the camera will be denied.
V4SynFloodBurst	Set Inq	<b>3</b> 2 to 60	Setting of continuing numbers of SYN Packet to be judged as attacks by IPv4 SYN Flood attack protection function.
V4SynFloodExpire	Set Inq	<b>60</b> 10 to 86400	Setting of the predetermined time to discard the results judged as an attack with IPv4 SYN Flood attack protection function. (Unit: second)
V4SynFloodLimit	Set Inq	<b>5</b> 1 to 1000	Setting of the possible access times per minute after limiting with the SYN Flood Attack Protection function of IPv4.
V4SynFloodProtection	Set Inq	on, <b>off</b>	On/Off Setting of the SYN Flood Attack Protection function of IPv4.
V6DosDefenseBurst<n>	Set Inq	<b>3</b> 2 to 600	Setting of consecutive access numbers to be judged as being attacked by IPv6 DoS Attack Protection function.
V6DosDefenseEnable<n>	Set Inq	on, <b>off</b>	On/Off Setting of the IPv6 DoS Attack Protection function.
V6DosDefenseExpire<n>	Set Inq	<b>60</b> 1 to 86400	Setting of the predetermined time to discard the results judged as a DoS attack by IPv6 DoS attack protection function. (Unit: second)

Parameter	Set Inq	Value	Description
V6DosDefenseLimit<n>	Set Inq	<b>5</b> 1 to 100	Setting of the number of times to defend against requests with IPv6 DoS Attack Protection function.
V6DosDefensePort<n>	Set Inq	<b>80</b> 0 to 65535	Setting of the port number to defend against requests with IPv6 DoS Attack Protection function.
V6FilterDefaultRule	Set Inq	<b>allow, reject</b>	Setting of the basic policy for IPv6 IP Filter.  allow : All the other accesses whose settings are not specified by V6FilterRule parameter will be allowed. reject : All the other accesses whose settings are not specified by V6FilterRule parameter will be denied.
V6FilterFunc	Set Inq	<b>on, off</b>	On/Off setting of IPv6 IP Filter function.
V6FilterRule	Set Inq	[Value1] <b>0</b> to 9  [Value2] IPv6 address  [Value3] <b>0</b> to 128  [Value4] <b>tcp, udp, icmp, all</b>  [Value5] <b>0</b> to 65535  [Value6] <b>allow, reject</b>	Setting of IPv6 Filter function rules. Up to 10 rules can be set.  V6FilterRule=Value1,Value21,Value31,Value41,Value51,Value61,Value12,Value22,Value32,Value42,Value52,Value62[,...,Value110,Value210,Value310,Value410,Value510,Value610]  [Value1] Setting of rule number Smaller value means higher priorities  [Value2] Setting of supported network address  [Value3] Setting of subnet mask value QoS supports (bit number from the left side of network address)  [Value4] Setting of supported protocol tcp : TCP udp : UDP icmp : ICMP In this case, port number (Value5) will be discarded, but it is still necessary. Filter will be applied for all ICMP messages. all : TCP, UDP, ICMP The port number (Value5) designation only works for TCP and UDP.  [Value5] Setting of supported port numbers When set to 0, all the Port numbers are supported.  [Value6] Setting of policy allow : Specified accesses to the camera will be allowed. reject : Specified accesses to the camera will be denied.
V6SynFloodBurst	Set Inq	<b>3</b> 2 to 60	Setting of continuing numbers of SYN Packet to be judged as attacks by IPv6 SYN Flood Attack Protection function.

Parameter	Set Inq	Value	Description
V6SynFloodExpire	Set Inq	<b>60</b> 10 to 86400	Setting of the predetermined time to discard the results judged as an attack with IPv6 SYN Flood Attack Protection function. (unit: second)
V6SynFloodLimit	Set Inq	<b>5</b> 1 to 1000	Setting of the possible access times per minute after limiting with IPv6 SYN Flood Attack Protection function.
V6SynFloodProtection	Set Inq	on, <b>off</b>	On/Off setting of IPv6 SYN Flood Attack Protection function.

### iplimit.cgi

Setting (Set): command/iplimit.cgi?<Parameter>=<Value>

Inquiry (Inq): command/inquiry.cgi?inq=iplimit

<n> of the parameter tail is the number between 1 to 10. Corresponds to the IP Limit 1 to 10 which can be registered to the camera.

The admin can access from even IP address whose access is denied by IP Limit.

Parameter (<n>: 1 to 10)	Set Inq	Value	Description
IpLimit<n>	Set Inq	[Value1] IPv4 or IPv6 address  [Value2] <b>8</b> to 128  [Value3] <b>allow</b> , deny	Setting that to be registered on numbers specified in <n>.  IpLimit<n>=Value1,Value2,Value3  [Value1] Setting of IP address  [Value2] Setting of subnet mask The numbers from 8 to 32 can be used for IPv4, and the ones from 8 to 128 for IPv6.  [Value3] Policy Setting of access policy  allow : Client with IP address specified in Value1 and Value2 will be allowed to access to the cameras deny : Client with IP address specified in Value1 and Value2 will be denied access to the cameras
IpLimitFunc	Set Inq	on, <b>off</b>	On/Off setting of IP Limit function.
IpLimitNum	Inq	10	IP Limit function returns the maximum numbers of IP addresses that can be registered.
IpLimitPolicy	Set Inq	allow, <b>deny</b>	Setting of IP Limit function policy.  allow : All the other accesses whose settings are not specified by IpLimit<n> parameter will be allowed. deny : All the other accesses whose settings are not specified by IpLimit<n> parameter will be denied.

## ssl.cgi

Setting (Set): command/ssl.cgi?<Parameter>=<Value>

Inquiry (Inq): command/inquiry.cgi?inq=ssl

Parameter	Set Inq	Value	Description
HttpsPort	Set Inq	<b>443</b> , 1024 to 65534	Setting of the port number used in HTTPS protocol.
SSLCertAvailability	Inq	1, 0	Returns the SSL certificates status. 1 : Certificates are enabled 0 : Certificates are disabled
SSLCertExtendedKeyUsage	Inq	0 to 128 characters	Returns the extended key usage of the SSL server certificates. Returns "<Put correct private key password>" if the private key password is not set correctly.
SSLCertInstalled	Inq	1, 0	Returns the SSL server certificates status. 1 : With certificates 0 : Without certificates
SSLCertIssuerDn	Inq	0 to 128 characters	Returns the issuer distinguished name of the SSL server certificates. Returns "<Put correct private key password>" if the private key password is not set correctly.
SSLCertMode	Set Inq	auto, <b>user</b>	Setting of server certificates mode to be used in HTTPS function. auto : Uses the self-signed certificates generated in the camera user : Uses imported external certificates
SSLCertSubjectDn	Inq	0 to 128 characters	Returns the subject distinguished name of the SSL server certificates.
SSLCertValidity	Inq	0 to 128 characters	Returns the validity period of the SSL server certificates. Returns "<Put correct private key password>" if the private key password is not set correctly.
SSLMode	Set Inq	<b>Plain</b> , SSL, Plain-SSL, SSL-Plain	Setting of the HTTPS function mode.  Plain : Works on HTTP only, disabled on HTTPS. SSL : Works on HTTPS only, disabled on HTTP. Plain-SSL : Works on both HTTP and HTTPS. SSL-Plain : Works on both HTTPS and HTTP. Works on HTTPS if it is not specified on access.
SSLPrivPassword	Set	0 to 50 characters	Setting of the server certificates private key. 50 or less alphanumeric characters can be set.
SSLPrivPasswordUsed	Inq	0, 1	Returns the status of server certificates private key to be used in HTTPS function.  0 : Not set 1 : Already set

## ssl-cert.cgi

Setting (Set): command/ssl-cert.cgi?<Parameter>=<Value>

Parameter	Set Inq	Value	Description
DeleteCert	Set	sslcert	Deletes certificates stored in the cameras. sslcert : Deletes CA certificates for SSL.
GenerateCert	Set	selfsignedcert	Generates a self-signed certificate for SSL.

## license.cgi

Inquiry (Inq): command/inquiry.cgi?inq=license

Parameter	Set Inq	Value	Description
QfhdLicenseSupport	Inq	0	Returns whether it corresponds with the license function or not.  0 : Does not correspond.

## ndi.cgi

Setting (Set): command/ndi.cgi?<Parameter>=<Value>

Inquiry (Inq): command/inquiry.cgi?inq=ndi

Parameter	Set Inq	Value	Description
NdiCameraName	Inq	0 to 8 characters [Default] SRG-A40 : A40 SRG-A12 : A12	Returns the camera name.
NdiRegistKey	Set Inq	0 to 32 characters	Used for NDI connection. Do not use directly.
NdiLicenseKeyValid	Inq	invalid, valid	Confirms the presence/absence of the NDI license.  invalid : Not installed. valid : Installed.
NdiSourceName	Set Inq	0 to 64 bytes	Sets the NDI Source Name.
NdiGroupEnable	Set Inq	on, <b>off</b>	Sets enable/disable for the NDI grouping function.  on : Enable off : Disable
NdiGroupName	Set Inq	0 to 128 bytes	Sets the NDI grouping function's group name.  Multiple group names can be specified separated by a comma.
NdiDiscoveryServer1	Set Inq	IPv4 Address	Sets the NDI discovery server.  This can be registered to both NdiDiscoveryServer1 and NdiDiscoveryServer2.
NdiDiscoveryServer2	Set Inq	IPv4 Address	Sets the NDI discovery server.  This can be registered to both NdiDiscoveryServer1 and NdiDiscoveryServer2.

Parameter	Set Inq	Value	Description
NdiTransferModeMulticastUdp	Set Inq	on, off	Sets enable/disable for the NDI Multicast streaming.  on : Enable off : Disable
NdiTransferMulticastPrefix	Set Inq	<b>239.255.0.0</b> IPv4 Address	Sets the Prefix of Multicast Address during NDI Multicast streaming.
NdiTransferMulticastNetmask	Set Inq	<b>255.255.0.0</b> IPv4 Address	Sets the Netmask which decides the range of Multicast Address during NDI Multicast streaming.
NdiTransferMulticastTTL	Set Inq	<b>3</b> 1 to 255	Sets the TTL during NDI Multicast streaming.
NdiTransferModeMultiTcp	Set Inq	on, off	Sets enable/disable for the NDI Multi-TCP mode.  on : Enable off : Disable
NdiTransferModeUnicastUdp	Set Inq	on, off	Sets enable/disable for the NDI Unicast UDP mode.  on : Enable off : Disable

### stream.cgi

Setting (Set): command/stream.cgi?<Parameter>=<Value>

Inquiry (Inq): command/inquiry.cgi?inq=stream

Parameter	Set Inq	Value	Description
StreamMode	Set Inq	rtsp, srt-caller, srt-listener, ndi_hx, off	Selects the streaming protocol. srt-caller and srt-listener can be set only when Audioln is on.
StreamStatus	Inq	invalid, off, streaming	Returns the status of SRT streaming. Shows the same status of UserData streaming. invalid: No status off: SRT-Caller Streaming not connected streaming: SRT-Caller Streaming being delivered

### srt.cgi

Setting (Set): command/srt.cgi?<Parameter>=<Value>

Inquiry (Inq): command/inquiry.cgi?inq=srt

Parameter	Set Inq	Value	Description
SrtTtl	Set Inq	<b>64</b> 1 to 255	Sets TTL value.
SrtPeerLatency	Set Inq	<b>120</b> 20 to 8000	Sets latency.
SrtArc	Set Inq	on, off	On/Off setting of the automatic rate control function.
SrtLastEvent	Inq	<b>0</b> to 9999	Returns the value corresponding to the event that has occurred for SRT.
SrtServerUrl1	Set Inq	<b>0</b> to 512 characters	A string starting with "srt://" (case without distinction) or an empty character (0 characters).

Parameter	Set Inq	Value	Description
SrtListenPort	Set Inq	<b>4201</b> 1024 to 65534	Sets the standby port number when working with the SRT-Listener.
SrtEncryption	Set Inq	<b>none</b> , aes-128, aes-256	Sets encryption settings.
SrtPassphrase	Set	<b>0</b> 10 to 79 characters	Sets the passphrase for encryption.
SrtPassphraseUsed	Inq	<b>0, 1</b>	0 : Not set 1 : Already set

### srtexe.cgi

Setting (Set): command/srtexe.cgi?<Parameter>=<Value>

Inquiry (Inq): None

Parameter	Set Inq	Value	Description
SrtStreaming	Set	on, off	Controls SRT streaming (start/stop). on: Start off: Stop

---

## Supported Codecs

The following codecs are supported with the RTSP streaming function of the cameras.

Video	Audio
H.264 H.265	AAC LC

---

## RTSP Request URL

RTSP request URLs of the cameras to achieve live streams are as follows.

Request URL	Description
rtsp://<camera_address>/video1	Requests video* bitstreams from codecs corresponding to the CGI parameter "ImageCodec1"** and its related parameters. * Audio bitstream can be transmitted together with this video stream depending on the situation. See "Stream Acquisition" (page 76). ** ImageCodec1 corresponds to Codec 1 setting of Image 1 in the administrator setting menu of the cameras.
rtsp://<camera_address>/video2	Requests video* bitstreams from codecs corresponding to the CGI parameter "ImageCodec2"** and its related parameters. * Audio bitstream can be transmitted together with this video stream depending on the situation. See "Stream Acquisition" (page 76). ** ImageCodec2 corresponds to Codec 2 setting of Image 2 in the administrator setting menu of the cameras.
rtsp://<camera_address>/audio	Requests audio bitstreams from codecs corresponding to the CGI parameter "AudInCodec"* and its related parameters. * AudInCodec corresponds to Audio codec setting in the administrator setting menu of the cameras.

RTSP port of the camera (RTSP server) is 554 by factory default. The port can be changed by using the "camera.cgi" CGI command with the "RTSPPort" CGI parameter.

### Note

RTSP Streaming is enabled when StreamMode is rtsp and RTSPServer is on.

---

# RTSP Methods

---

## Supported Methods

The cameras support the following RTSP methods.

Supported Method
OPTIONS
DESCRIBE
SETUP
PLAY
TEARDOWN
GET_PARAMETER
SET_PARAMETER
PAUSE

For details about the RTSP methods listed above, refer to IETF RFC 2326.

## Typical Sequence of RTSP Communication

Overview of a typical RTSP communication sequence between the camera (RTSP server) and a client is as shown below.

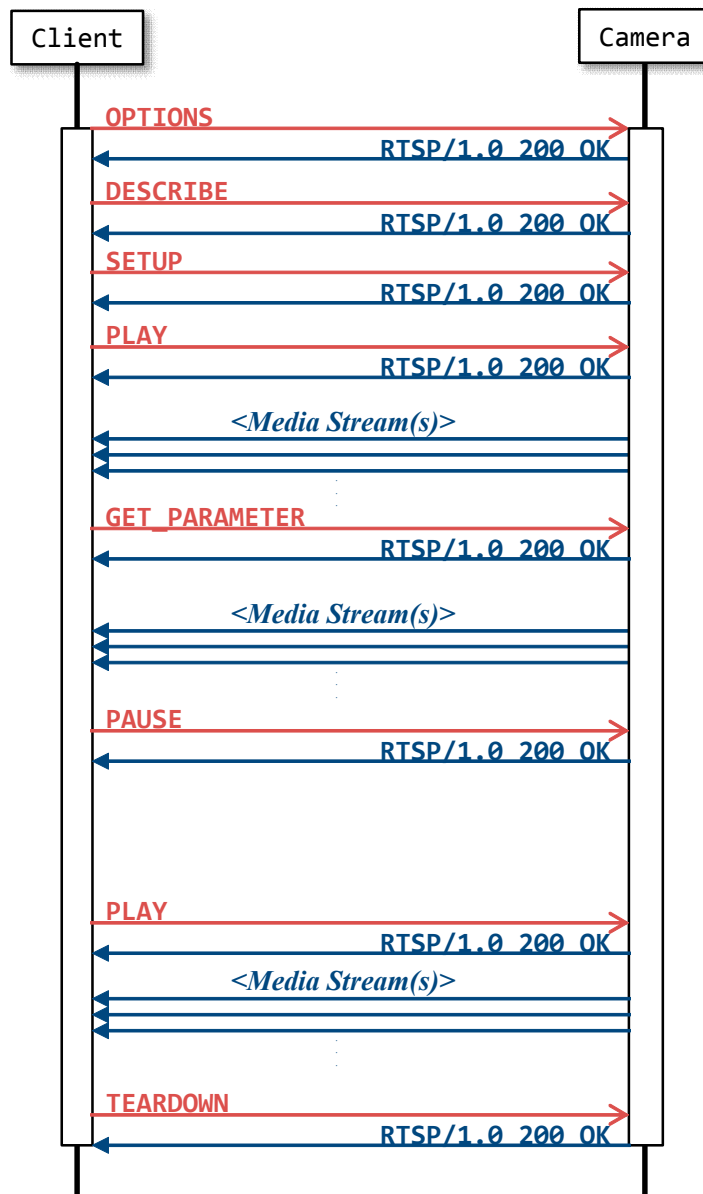

The RTSP "GET\_PARAMETER" method in the sequence above is used to keep the RTSP streaming alive. You can pause the streaming by using PAUSE command after starting live streaming by using PLAY command. To resume, send PLAY command again. The cameras resume video streaming at the current point by forcing IDR frame insertion at the point of reception of PLAY resume request. Videos before the pause and after the resume are not in sequence. For details on this topic, refer to "Stream Acquisition" (page 76).

---

# Stream Acquisition

## <Transfer Protocols>

The RTSP function of the cameras supports the following transfer protocols to stream video and/or audio from the camera to client(s).

- a) TCP bitstream
- b) UDP unicast bitstream

Details of each case above are described in the following sections.

## <Number of Media Streams>

The cameras support multiple codec simultaneously as mentioned in the previous "RTSP Request URL" (page 73). The number of media streams in an RTSP session of the camera is up to 5.

## <RTSP Session Timeout>

Time-out period of RTSP session on the cameras can be set with "RTSPTimeout" of CGI parameter. Default setting is 60 (unit: second). When the value is set to 0, RTSP session will not time-out.

For more information to change the setting of Time-out period of RTSP from Admin menu via Web browser, refer to "Streaming" tab in "Streaming" menu in Operating Instructions.

The RTSP session timeout value of the camera is indicated to a client as a "timeout" parameter (in seconds) in RTSP response to the "SETUP" request. However, when the timeout value is set to 0, the timeout parameter does not exist in the response.

To keep an RTSP stream alive, examples in this document use the RTSP "GET\_PARAMETER" method before the camera automatically closes the RTSP session in accordance with the timeout parameter.

## <Closing RTSP Session>

To close UDP port linked to RTSP session and this session safely, use RTSP method "TEARDOWN."

# Video Stream Acquisition

## TCP Bitstream (Video)

The following diagram and captured packets show an example of a client acquiring a video bitstream via TCP in a situation where AudioIn is off.

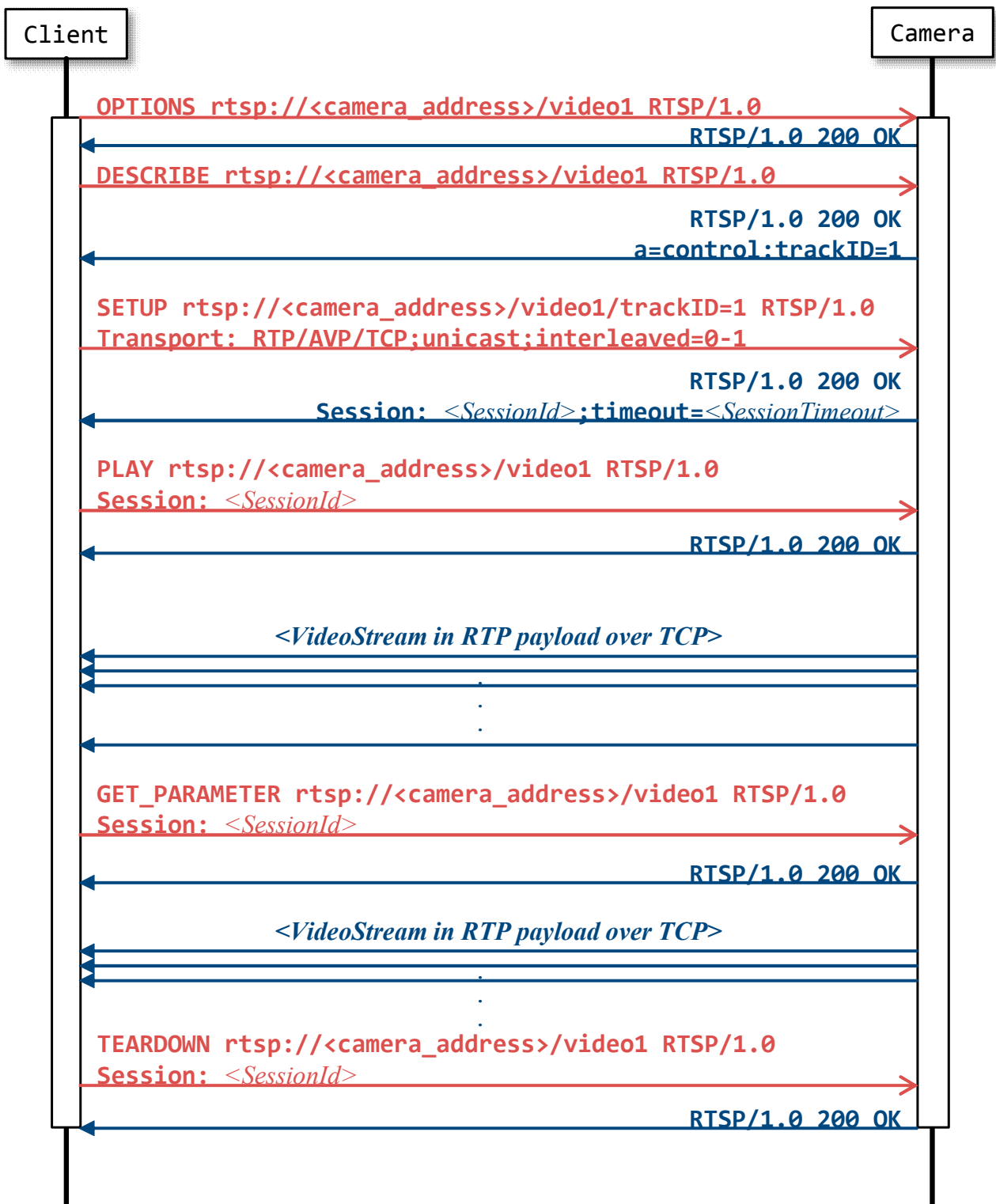

```
OPTIONS rtsp://<camera_address>/video1 RTSP/1.0\r\n
CSeq: 1\r\n
User-Agent: <UserAgent>\r\n
\r\n
RTSP/1.0 200 OK\r\n
Server: <ServerName>\r\n
CSeq: 1\r\n
Public: DESCRIBE, SETUP, TEARDOWN, PLAY, OPTIONS, SET_PARAMETER, GET_PARAMETER\r\n
\r\n
DESCRIBE rtsp://<camera_address>/video1 RTSP/1.0\r\n
CSeq: 2\r\n
User-Agent <UserAgent>\r\n
\r\n
RTSP/1.0 200 OK\r\n
Server: <ServerName>\r\n
CSeq: 2\r\n
Content-Length: <Length>\r\n
Content-Type: application/sdp\r\n
Content-Base: rtsp://<camera_address>/video1/\r\n
\r\n
v=<ProtocolVersion>\r\n
o=- <SessionIdForOrigin> 1 IN IP4 <camera_address>\r\n
s=<SessionName>\r\n
t=0 0\r\n
a=range:npt=now-\r\n
c=IN IP4 <ConnectionAddress>\r\n
m=<MediaNameAndTransportAddress>\r\n
a=rtpmap:<PayloadType> <EncodingName> /<ClockRate> \r\n
a=control:trackID=1\r\n
a=framerate:<FrameRate>\r\n
a=fmtp:<Format> <FormatSpecificParameters>\r\n
SETUP rtsp://<camera_address>/video1/trackID=1 RTSP/1.0\r\n
CSeq: 3\r\n
Transport: RTP/AVP/TCP;unicast;interleaved=0-1\r\n
User-Agent: <UserAgent>\r\n
\r\n
RTSP/1.0 200 OK\r\n
Server: <ServerName>\r\n
CSeq: 3\r\n
```

```
Session: <SessionId>[;timeout=<SessionTimeout>]\r\n
Cache-Control: must-revalidate\r\n
Transport: RTP/AVP/TCP;interleaved=0-1;ssrc=<SSRC>\r\n
\r\n
```

```
PLAY rtsp://<camera_address>/video1 RTSP/1.0\r\n
```

```
CSeq: 4\r\n
Session: <SessionId>\r\n
Range: npt=0.000-\r\n
User-Agent: <UserAgent>\r\n
\r\n
```

```
RTSP/1.0 200 OK\r\n
Server: <ServerName>\r\n
CSeq: 4\r\n
Session: <SessionId>\r\n
RTP-Info: url=trackID=1;seq=<SequenceNumber>;rtptime=...\r\n
\r\n
```

```
<Video stream in RTP payload over TCP>
```

```
GET_PARAMETER rtsp://<camera_address>/video1 RTSP/1.0\r\n
```

```
CSeq: 5\r\n
Session: <SessionId>\r\n
User-Agent: <UserAgent>\r\n
\r\n
```

```
<Video stream in RTP payload over TCP>
```

```
TEARDOWN rtsp://<camera_address>/video1 RTSP/1.0\r\n
```

```
CSeq: 6\r\n
Session: <SessionId>\r\n
User-Agent: <UserAgent>\r\n
\r\n
```

```
RTSP/1.0 200 OK\r\n
Server: <ServerName>\r\n
CSeq: 6\r\n
Session: <SessionId>\r\n
\r\n
```

## UDP Unicast Bitstream (Video)

The following diagram (page 81) and captured packets (page 82 to 83) show an example of a client acquiring a video bitstream via UDP unicast in a situation where AudioIn is off.

As for the UDP port numbers to be used for sending RTP/RTCP packets, "Client\_port" parameter value which is added to RTSP SETUP request will be used for the client port. As for the server port (port number at the cameras side), CGI parameters shown in the table below will be applied.

For more information to set these values from Admin menu via Web browser, refer to "Unicast streaming" of "Streaming" tab in "Streaming" menu in Operating Instructions.

CGI Parameter	Corresponding to
RTSPUcVideoPort1	UDP unicast ports for "ImageCodec1" live stream.
RTSPUcVideoPort2	UDP unicast ports for "ImageCodec2" live stream.
RTSPUcAudioPort	UDP unicast ports for "AudInCodec" live stream.

If the UDP port number specified in the parameter above is already used, the cameras assign the number close to the port number specified by the parameter. For the software implementation at the client side, implement to accept RTP/RTCP data using port number described in "server\_port" which is included in SETUP response (Do not refer to the CGI parameter setting above).

# UDP Unicast Bitstream (Video) Diagram

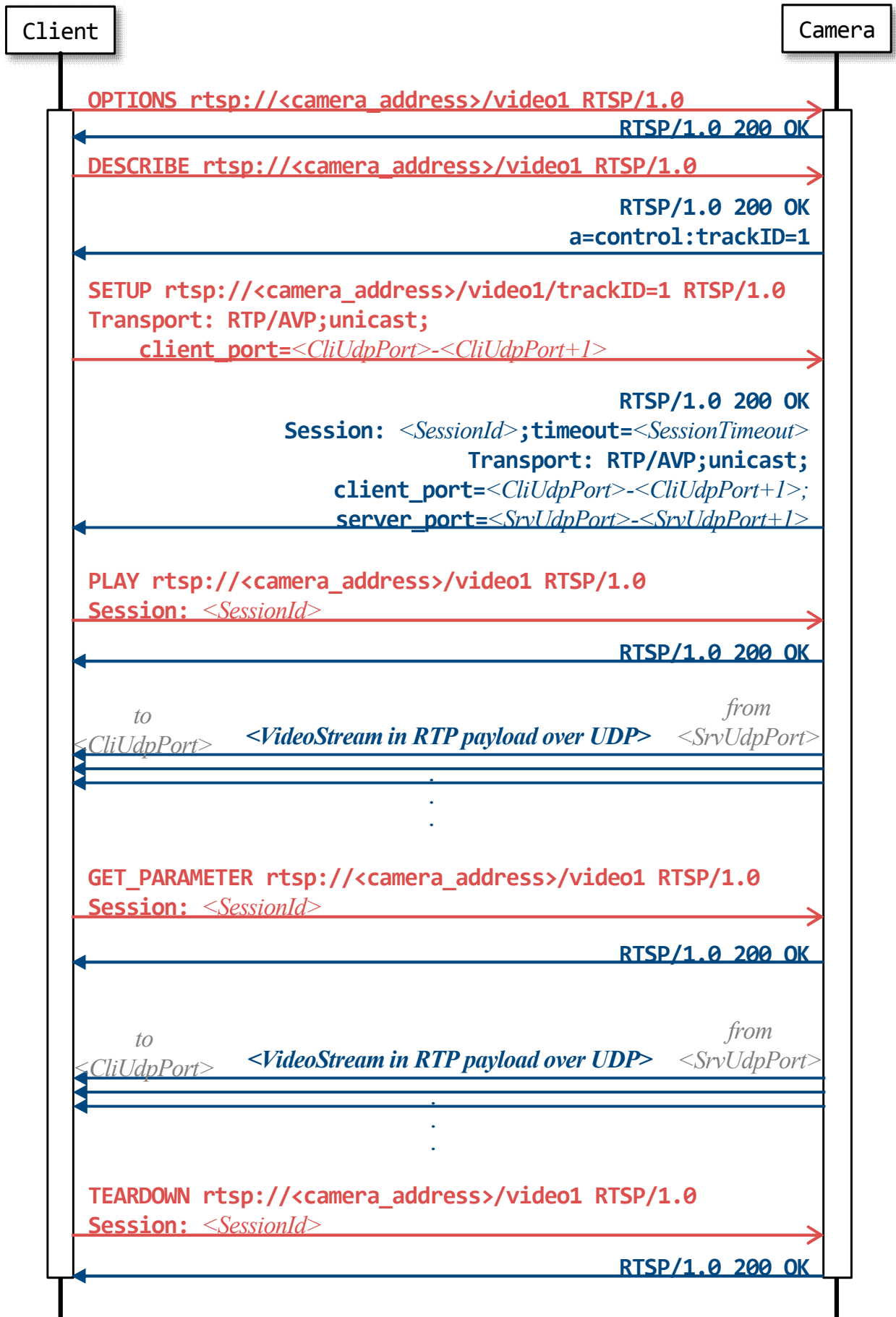

## UDP Unicast Bitstream (Video) Packet Capture

```
OPTIONS rtsp:// <camera_address>/video1 RTSP/1.0\r\n
CSeq: 1\r\n
User-Agent: <UserAgent>\r\n
\r\n
RTSP/1.0 200 OK\r\n
Server: <ServerName>\r\n
CSeq: 1\r\n
Public: DESCRIBE, SETUP, TEARDOWN, PLAY, OPTIONS, SET_PARAMETER, GET_PARAMETER\r\n
\r\n
DESCRIBE rtsp:// <camera_address>/video1 RTSP/1.0\r\n
CSeq: 2\r\n
User-Agent: <UserAgent>\r\n
\r\n
RTSP/1.0 200 OK\r\n
Server: <ServerName>\r\n
CSeq: 2\r\n
Content-Length: <Length>\r\n
Content-Type: application/sdp\r\n
Content-Base: rtsp:// <Address>/video1/\r\n
\r\n
v=0\r\n
o=- <SessionIdForOrigin> 1 IN IP4 <camera_address>\r\n
s=<SessionName>\r\n
t=0 0\r\n
a=range:npt=now-\r\n
c=IN IP4 <ConnectionAddress>\r\n
m=<MediaNameAndTransportAddress>\r\n
a=rtpmap: <PayloadType> <EncodingName> / <ClockRate> \r\n
a=control:trackID=1\r\n
a=framerate: <FrameRate>\r\n
a=fmtp: <Format> <FormatSpecificParameters>\r\n
SETUP rtsp:// <camera_address>/video1/trackID=1 RTSP/1.0\r\n
CSeq: 3\r\n
Transport: RTP/AVP;unicast;client_port=<CliUdpPort>-<CliUdpPort+1>\r\n
User-Agent: <UserAgent>\r\n
\r\n
RTSP/1.0 200 OK\r\n
Server: <ServerName>\r\n
CSeq: 3\r\n
Session: <SessionId> [ ;timeout=<SessionTimeout> ]\r\n
Cache-Control: must-revalidate\r\n
Transport: RTP/AVP;unicast;client_port=<CliUdpPort>-<CliUdpPort+1>;source=<SourceAddress>;server_port=<SrvUdpPort>-<SrvUdpPort+1>;ssrc=<SSRC>\r\n
\r\n
```

```
PLAY rtsp:// <camera_address>/video1 RTSP/1.0\r\n
CSeq: 4\r\n
Session: <SessionId>\r\n
Range: npt=0.000-\r\n
User-Agent: <UserAgent>\r\n
\r\n

RTSP/1.0 200 OK\r\n
Server: <ServerName>\r\n
CSeq: 4\r\n
Session: <SessionId>\r\n
RTP-Info: url=trackID=1;seq= <SequenceNumber>;rtptime=...\r\n
\r\n

<Video stream in RTP payload over UDP unicast>

GET_PARAMETER rtsp:// <camera_address>/video1 RTSP/1.0\r\n
CSeq: 5\r\n
Session: <SessionId>\r\n
User-Agent: <UserAgent>\r\n
\r\n

<Video stream in RTP payload over UDP unicast>

TEARDOWN rtsp:// <camera_address>/video1 RTSP/1.0\r\n
CSeq: 6\r\n
Session: <SessionId>\r\n
User-Agent: <UserAgent>\r\n
\r\n

RTSP/1.0 200 OK\r\n
Server: <ServerName>\r\n
CSeq: 6\r\n
Session: <SessionId>\r\n
\r\n
```

## Acquiring Both Video and Audio Bitstreams

In case Audioln is on and a client requests a video stream, the camera simultaneously transmits the video stream and an audio stream in an RTSP session. The following captured packets show an example of simultaneous video bitstream and audio bitstream acquisition from the camera.

As you can see in the example, session descriptions in RTSP response to "DESCRIBE" request contains two media descriptions — the first one is for video, the second one is for audio.

```
DESCRIBE rtsp://<camera_address>/video1 RTSP/1.0\r\n
CSeq: 3\r\n
User-Agent: <UserAgent>\r\n
\r\n
RTSP/1.0 200 OK\r\n
Server: <ServerName>\r\n
CSeq: 3\r\n
Content-Length: <Length>\r\n
Content-Type: application/sdp\r\n
Content-Base: rtsp://<camera_address>/video1/\r\n
\r\n
v=0\r\n
o=- <SessionIdForOrigin> 1 IN IP4 <camera_address>\r\n
s=<SessionName>\r\n
t=0 0\r\n
a=range:npt=now- \r\n
c=IN IP4 <ConnectionAddress>\r\n
\r\n
m=video 0 RTP/AVP 105\r\n
a=rtpmap:105 H264/90000\r\n
a=control:trackID=1\r\n
a=framerate:30.0\r\n
a=fmtp:105 packetization-mode=1; profile-level-id=640002a; sprop-parameter-sets=Z2QAkqsaoHgCJ+XAWiAAAH0gAB1MEI=,a048sA==\r\n
\r\n
m=audio 0 RTP/AVP 103\r\n
a=rtpmap:101 mpeg4-generic/48000/2\r\n
a=control:trackID=2\r\n
a=fmtp:103 profile-level-id=2; streamtype=5; mode=AAC-hbr; config=1190; SizeLength=13; IndexLength=3; IndexDeltaLength=3; Profile=1; bitrate=256000;\r\n
\r\n
SETUP rtsp://<camera_address>/video1/trackID=1 RTSP/1.0\r\n
CSeq: 4\r\n
User-Agent: <UserAgent>\r\n
Transport: RTP/AVP;unicast;client_port=<CliUdpPrt>-<CliUdpPort+1>\r\n
```

```

\r\n
RTSP/1.0 200 OK
Server: <ServerName>\r\n
CSeq: 4\r\n
Session: <SessionId>;timeout=<SessionTimeout>\r\n
Cache-Control: must-revalidate\r\n
Transport: RTP/AVP;unicast;client_port=<CliUdpPrt>-<CliUdpPrt+1>;source=<SrcIpAdd
ress>;server_port=<ServerPort>;ssrc=<SSRC>\r\n
SETUP rtsp://<camera_address>/video1/trackID=2 RTSP/1.0\r\n
CSeq: 5\r\n
User-Agent: <UserAgent>\r\n
Transport: RTP/AVP;unicast;client_port=<CliUdpPrt>-<CliUdpPrt+1>\r\n
Session: <SessionId>\r\n
\r\n
RTSP/1.0 200 OK\r\n
Server: <ServerName>\r\n
CSeq: 5\r\n
Session: <SessionId>;timeout=<SessionTimeout>\r\n
Cache-Control: must-revalidate\r\n
Transport: RTP/AVP;unicast;client_port=<CliUdpPrt>-<CliUdpPrt+1>;source=<SrcIpAdd
ress>;server_port=<ServerPort>;ssrc=<SSRC>\r\n
PLAY rtsp://<camera_address>/video1/ RTSP/1.0\r\n
CSeq: 6\r\n
User-Agent: <UserAgent>\r\n
Session: <SessionId>\r\n
Range: npt=0.000- \r\n
\r\n
RTSP/1.0 200 OK\r\n
Server: <ServerName>\r\n
CSeq: 6\r\n
Session: <SessionId>\r\n
RTP-Info: url=trackID=1;seq=<SeqNoTrackId1>;rtptime=0,url=trackID=2;seq=<SeqNum
TrackId2>;rtptime=0\r\n

```

## rtpmap Attribute

rtpmap attribute values in RTSP response to “DESCRIBE” request vary depending on the codec of media streams. Here are some examples.

Codec	rtpmap Attribute Value
H.264	a=rtpmap:105 H264/90000\r\n
H.265	a=rtpmap:96 H265/90000\r\n
AAC (128 kbps)	a=rtpmap:102 mpeg4-generic/48000/2\r\n
AAC (256 kbps)	a=rtpmap:103 mpeg4-generic/48000/2\r\n

# RTP/RTCP

## RTP Header Fields

The RTP header has the following format.

0	1	2	3	4	5	6	7	8	9	A	B	C	D	E	F	0	1	2	3	4	5	6	7	8	9	A	B	C	D	E	F
V			P	X	CC				M	PT						Sequence Number															
Timestamp																															
Synchronization Source (SSRC) Identifier																															
Contributing Source (CSRC) Identifier																															
Payload data																															

Field	Bit Length	Description
Version	2	This field identifies the version of RTP. The version defined by this specification is two (2).
Padding	1	If the padding bit is set, the packet contains one or more additional padding octets at the end which are not part of the payload. The last octet of the padding contains a count of how many padding octets should be ignored.
Extension	1	If the extension bit is set, the fixed header is followed by exactly one extension header.
CSRC Count	4	The CSRC count contains the number of CSRC identifiers that follow the fixed header.
Marker	1	The interpretation of the marker is defined by a profile. It is intended to allow significant events such as frame boundaries to be marked in the packet stream.
Payload Type	7	This field identifies the format of the RTP payload and determines its interpretation by the application.
Sequence Number	16	The sequence number increments by one for each RTP data packet sent, and may be used by the receiver which detects packet loss and restores packet sequence.
Timestamp	32	The timestamp reflects the sampling instant of the first octet in the RTP data packet. The sampling instant must be derived from a clock that increments monotonically and linearly in time to allow synchronization and jitter calculations.
Synchronization Source (SSRC) Identifier	32	The SSRC field identifies the synchronization source. This identifier is chosen randomly, with the intent that no two synchronization sources within the same RTP session will have the same SSRC identifier.
Contributing Source (CSRC) Identifier	32	The CSRC list identifies the contributing sources for the payload contained in this packet. The number of identifiers is given by the CC field.

## SR: Sender Report RTCP Packet

The RTCP Sender report's header has the following format.

0	1	2	3	4	5	6	7	8	9	A	B	C	D	E	F	0	1	2	3	4	5	6	7	8	9	A	B	C	D	E	F
V		P	RC					PT								Length															
Synchronization Source (SSRC) Identifier																															
NTP Timestamp (32bit x 2)																															
RTP Timestamp																															
Sender's Packet Count																															
Sender's Octet Count																															
Report Block 1st																															
Report Block 2nd																															

Field	Bit Length	Description
Version	2	Identifies the version of RTP, which is the same in RTCP packets as in RTP data packets. The version defined by this specification is two (2).
Padding	1	If the padding bit is set, the packet contains one or more additional padding octets at the end which are not part of the payload. The last octet of the padding contains a count of how many padding octets should be ignored.
Reception Report Count	5	The number of reception report blocks contained in this packet. A value of zero is valid.
Packet Type	8	Contains the constant 200 to identify this as an RTCP SR packet.
Length	16	The length of this RTCP packet in 32-bit words minus one, including the header and any padding.
Synchronization Source (SSRC) Identifier	32	The synchronization source identifies the originator of this SR packet.
NTP Timestamp	64	Indicates the wallclock time when this report was sent. In combination with timestamps returned in reception reports from other receivers, round-trip propagation to those receivers can be measured.
RTP Timestamp	32	Corresponds to the same time as the NTP timestamp (above), but in the same units and with the same random offset as the RTP timestamps in data packets.
Sender's Packet Count	32	The total number of RTP data packets transmitted by the sender since starting transmission up until the time this SR packet was generated.
Sender's Octet Count	32	The total number of payload octets (i.e., not including header or padding) transmitted in RTP data packets by the sender since starting transmission up until the time this SR packet was generated. The count is reset if the sender changes its SSRC identifier.

# Userdata Information in Video Bitstream

Userdata field (supplemental information) is added to the video bitstream delivered by RTSP streaming function. This chapter describes the data structure of Userdata field this camera supports.

## Userdata Information Under H.264 Video Codec

The data structure of Userdata field where the video codec is set to H.264 is described. The format of the data is like below, when H.264 Userdata is sent from the cameras as RTP Packet.

RTP Header	NAL Unit Octet							Payload Type	Size	UUID	User Data	End Code	
	0	1	2	3	4	5	6						7
	F	NRI		NAL Unit Type									
	0	0	6										

In the format above, the data details except RTP Header is described in the table below.

Field		Byte Length	Offset	Description
NAL Unit Octet		1	0	This field is 0x06.
Payload Type		1	1	This field is 0x05.
Size		1	2	This field shows the total byte length of UUID and "user data."
UUID		16	3	This field shows the MAC address of the camera.
User Data	Date Time	33	19	This field shows the local time. [example] CamTim: _2020-01-01_Wed_15:15:15\r\n
	Frame Rate	15	52	This field shows the current frame rate of the video bitstream. [example] FrmRate: _60.0\r\n
	Time Stamp	22	67	This field shows the value which is incremented by 90kHz timer (about 11 milliseconds per one increment). [example] TimeStamp: _0000000001\r\n
	PTZ Position	26	89	This field shows the pan, tilt and zoom position. [example] CamPos: _111ppppptttzzzzm\r\n If a camera supports PTZ, first 3 digits are 111. Next "pppp", "tttt" and "zzzz" show the pan, tilt and zoom position respectively. "m" at the bottom represents the status below. "M" : Camera is working "S" : Camera is paused
	Tally	10	115	This field shows the Tally lamp status. 0: off / 1: on [example] Tally: _0\r\n
Stream	14	125	This field shows the streaming status. [example] Stream: _xxxx\r\n "IVLD" : No status "OFF_" : Streaming not connected "STM_" : Streaming	
End Code		1	139	This field is 0x80.

## Userdata Information Under H.265 Video Codec

The data structure of Userdata field where the video codec is set to H.265 is described. The format of the data is like below, when H.265 Userdata is sent from the cameras as RTP Packet.

RTP Header	NAL Unit Header														Payload Type	Size	UUID	User Data	End Code		
	0	1	2	3	4	5	6	7	0	1	2	3	4	5						6	7
	Type							Layer ID												TID	
	0	0x27						0							1	0x05					

In the format above, the data details except RTP Header is described in the table below.

Field	Byte Length	Offset	Description	
NAL Unit Header	2	0	This field is 0x4e01.	
Payload Type	1	2	This field is 0x05.	
Size	1	3	This field shows the total byte length of UUID and "user data."	
UUID	16	4	This field shows the MAC address of the camera.	
User Data	Date Time	33	20	This field shows the local time. [example] CamTim: _2020-01-01_Wed_15:15:15\r\n
	Frame Rate	15	53	This field shows the current frame rate of the video bitstream. [example] FrmRate: _60.0\r\n
	Time Stamp	22	68	This field shows the value which is incremented by 90kHz timer (about 11 milliseconds per one increment). [example] TimeStamp: _0000000001\r\n
	PTZ Position	26	90	This field shows the pan, tilt and zoom position. [example] CamPos: _111pppptttzzzm\r\n If a camera supports PTZ, first 3 digits are 111. Next "pppp," "tttt" and "zzzz" show the pan, tilt and zoom position respectively. "m" at the bottom represents the status below. "M" : Camera is working "S" : Camera is paused
	Tally	10	116	This field shows the Tally lamp status. 0: off / 1: on [example] Tally: _0\r\n
	Stream	14	126	This field shows the streaming status. [example] Stream: _xxx\r\n "IVLD" : No status "OFF_" : Streaming not connected "STM_" : Streaming
End Code	1	140	This field is 0x80.	

# VISCA/CGI Command Setting Values

## SHUTTER/MIN SHUTTER/SHUTTER

VISCA Parameter*	CGI Value	Video output format		
		2160/29.97p 1080/59.94p 1080/59.94i 720/59.94p	2160/25p 1080/50p 1080/50i 720/50p	2160/23.98p 1080/23.98p
SHUTTER MIN SHUTTER	SHUTTER			
21	33	1/10000	1/10000	1/10000
20	32	1/6000	1/6000	1/4800
1F	31	1/4000	1/3500	1/2400
1E	30	1/3000	1/2500	1/1200
1D	29	1/2000	1/1750	1/576
1C	28	1/1500	1/1250	1/400
1B	27	1/1000	1/1000	1/288
1A	26	1/725	1/600	1/200
19	25	1/500	1/425	1/192
18	24	1/350	1/300	1/144
17	23	1/250	1/215	1/120
16	22	1/180	1/150	1/100
15	21	1/125	1/120	1/96
14	20	1/100	1/100	1/60
13	19	1/90	1/60	1/50
12	18	1/60	1/50	1/48
11	17	1/50	1/30	1/40
10	16	1/30	1/25	1/25
0F	15	1/20	1/20	1/24
0E	14	1/15	1/15	1/20
0D	13	1/10	1/12	1/12
0C	12	1/8	1/8	1/8
0B	11	1/6	1/6	1/6
0A	10	1/4	1/4	1/4
09	9	1/3	1/3	1/3
08	8	1/2	1/2	1/2
07	7	2/3	2/3	2/3
06	6	1/1	1/1	1/1

\* VISCA parameter uses hexadecimal digits.

## MAX SHUTTER

VISCA Parameter*	Video output format		
	2160/29.97p 1080/59.94p 1080/59.94i 720/59.94p	2160/25p 1080/50p 1080/50i 720/50p	2160/23.98p 1080/23.98p
SHUTTER MIN SHUTTER			
21	1/10000	1/10000	1/10000
20	1/6000	1/6000	1/4800
1F	1/4000	1/3500	1/2400
1E	1/3000	1/2500	1/1200
1D	1/2000	1/1750	1/576
1C	1/1500	1/1250	1/400
1B	1/1000	1/1000	1/288
1A	1/725	1/600	1/200
19	1/500	1/425	1/192
18	1/350	1/300	1/144
17	1/250	1/215	1/120
16	1/180	1/150	1/100
15	1/125	1/120	1/96
14	1/100	1/100	1/60
13	1/90	1/60	1/50
12	1/60	1/50	1/48
11	1/50	1/30	1/40
10	1/30	1/25	1/25
0F	-	-	1/24

\* VISCA parameter uses hexadecimal digits.

## IRIS/IRIS

VISCA Parameter*	CGI Value	F value
IRIS	IRIS	
19	25	F2.0(OOPEN)
18	24	F2.2
17	23	F2.4
16	22	F2.6
15	21	F2.8
14	20	F3.1
13	19	F3.4
12	18	F3.7
11	17	F4.0
10	16	F4.4
0F	15	F4.8
0E	14	F5.2
0D	13	F5.6
0C	12	F6.2
0B	11	F6.8
0A	10	F7.3
09	9	F8.0
08	8	F8.7
07	7	F9.6
06	6	F10
05	5	F11
00	0	CLOSE

\* VISCA parameter uses hexadecimal digits.

## GAIN/GAIN

VISCA Parameter* <sup>1</sup>	CGI Value	Gain value
GAIN	GAIN	
11* <sup>2</sup>	17* <sup>2</sup>	48 dB
10* <sup>2</sup>	16* <sup>2</sup>	45 dB
0F* <sup>2</sup>	15* <sup>2</sup>	42 dB
0E* <sup>2</sup>	14* <sup>2</sup>	39 dB
0D	13	36 dB
0C	12	33 dB
0B	11	30 dB
0A	10	27 dB
09	9	24 dB
08	8	21 dB
07	7	18 dB
06	6	15 dB
05	5	12 dB
04	4	9 dB
03	3	6 dB
02	2	3 dB
01	1	0 dB

\*1 VISCA parameter uses hexadecimal digits.

\*2 Can be set only when the high-sensitivity mode is on.

## GAIN LIMIT/AUTO GAIN MAX. VALUE

VISCA Parameter*	CGI Value	High-sensitivity mode	High-sensitivity mode
		Off	On
Gain Limit	Auto Gain MAX. Value		
D	13	36 dB	48 dB
C	12	33 dB	45 dB
B	11	30 dB	42 dB
A	10	27 dB	39 dB
9	9	24 dB	36 dB
8	8	21 dB	33 dB
7	7	18 dB	30 dB
6	6	15 dB	27 dB
5	5	12 dB	24 dB
4	4	9 dB	21 dB

\* VISCA parameter uses hexadecimal digits.

## EXPOSURE COMPENSATION

VISCA Parameter*	CGI Value	Gain value
Exposure Compensation	Exposure Compensation	
0E	14	+ 10.5 dB
0D	13	+ 9.0 dB
0C	12	+ 7.5 dB
0B	11	+ 6.0 dB
0A	10	+ 4.5 dB
09	9	+ 3.0 dB
08	8	+ 1.5 dB
07	7	0.0 dB
06	6	- 1.5 dB
05	5	- 3.0 dB
04	4	- 4.5 dB
03	3	- 6.0 dB
02	2	- 7.5 dB
01	1	- 9.0 dB
00	0	- 10.5 dB

\* VISCA parameter uses hexadecimal digits.

## IMAGE SIZE

CGI Value			Image Size
ImageSize1	ImageSize2	ImageSize3	
3840,2160	-	-	3840×2160
1920,1080	1920,1080	-	1920×1080
1280,720	1280,720	1280,720	1280×720
640,360	640,360	640,360	640×360

# PAN/TILT POSITION

	VISCA Parameter*	CGI Value*	Position
Pan	DE00	de00	- 170 degrees
	0000	0000	0 degrees
	2200	2200	+ 170 degrees
Tilt (Image Flip: OFF) (Eflip: Off)	FC00	fc00	- 20 degrees
	0000	0000	0 degrees
	1200	1200	+ 90 degrees
Tilt (Image Flip: ON) (Eflip: On)	EE00	ee00	- 90 degrees
	0000	0000	0 degrees
	0400	0400	+ 20 degrees

\* Parameters and Values use hexadecimal digits.

**Image Flip: OFF / Eflip: Off** \* The values inside [ ] is described as [VISCA Parameter/CGI Value].

## Top

+170 degrees [2200/2200]: Right end  
-170 degrees [DE00/de00]: Left end

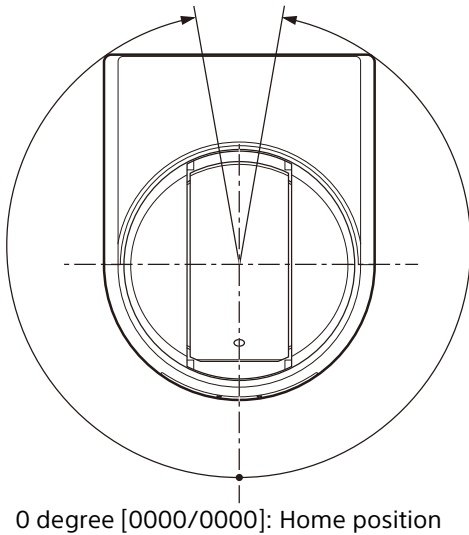

## Side

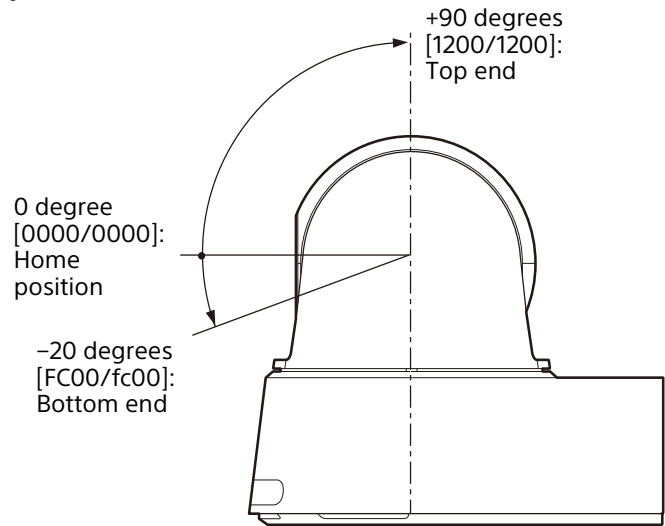

**Image Flip: ON / Eflip: On**

## Top

+170 degrees [2200/2200]: Right end  
-170 degrees [DE00/de00]: Left end

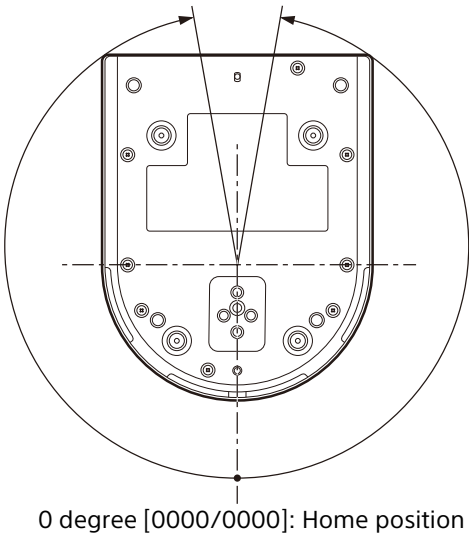

## Side

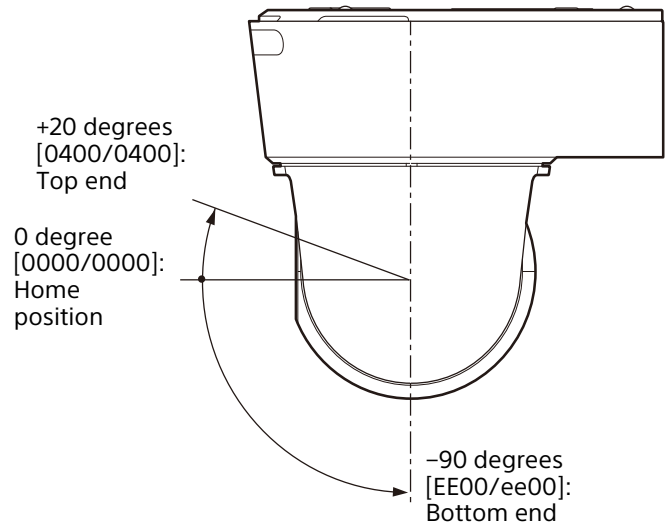

## PAN/TILT SPEED

VISCA Parameter*	CGI Value	Rotation speed (for reference)	
Pan/Tilt Speed (PAN/TILT SLOW=OFF)	Pan/Tilt Speed (SlowPanTiltMode : off)	Pan (deg/sec)	Tilt (deg/sec)
18	24	101	-
17	23	91	91
16	22	84	84
15	21	80	80
14	20	72	72
13	19	69	69
12	18	64	64
11	17	62	62
10	16	57	57
0F	15	54	54
0E	14	49	49
0D	13	47	47
0C	12	43	43
0B	11	41	41
0A	10	27	27
09	9	24	24
08	8	23	23
07	7	11	11
06	6	6.7	6.7
05	5	2.9	2.9
04	4	2.2	2.2
03	3	1.6	1.6
02	2	1.3	1.3
01	1	1.1	1.1

\* VISCA parameter uses hexadecimal digits.

VISCA Parameter *1*2	CGI Value *3	Rotation speed (for reference)	
Pan/Tilt Speed (PAN/TILT SLOW=ON)	Pan/Tilt Speed (SlowPanTiltMode : on)	Pan (deg/sec)	Tilt (deg/sec)
18	24	60	-
17	23	26.4	91
16	22	13.2	84
15	21	10.8	80
14	20	9.6	72
13	19	8.9	69
12	18	8.1	64
11	17	7.3	62
10	16	6.5	57
0F	15	5.9	54
0E	14	5.3	49
0D	13	4.7	47
0C	12	4.1	43
0B	11	3.5	41
0A	10	3.1	27
09	9	2.7	24
08	8	2.3	23
07	7	1.9	11
06	6	1.5	6.7
05	5	1.3	2.9
04	4	1.1	2.2
03	3	0.9	1.6
02	2	0.7	1.3
01	1	0.5	1.1

\*1 VISCA parameter uses hexadecimal digits.

\*2 Up to 7F can be specified by VISCA, however 19 to 7F are for the maintenance.

\*3 Up to 128 can be specified by CGI, however 25 to 128 are for the maintenance.

## PRESET RUN SPEED

VISCA Parameter*	CGI Value	Rotation speed (for reference)	
Preset run speed	Preset run speed	Pan (deg/sec)	Tilt (deg/sec)
19	25	300	126
18	24	101	91
17	23	91	91
16	22	84	84
15	21	80	80
14	20	72	72
13	19	69	69
12	18	64	64
11	17	62	62
10	16	57	57
0F	15	54	54
0E	14	49	49
0D	13	47	47
0C	12	43	43
0B	11	41	41
0A	10	27	27
09	9	24	24
08	8	23	23
07	7	11	11
06	6	6.7	6.7
05	5	2.9	2.9
04	4	2.2	2.2
03	3	1.6	1.6
02	2	1.3	1.3
01	1	1.1	1.1

\* VISCA parameter uses hexadecimal digits.

## FOCUS DISTANCE

VISCA Parameter*	CGI Value*	Focus distance (for reference)
F000	F000	0.08 m
E000	E000	0.1 m
D000	D000	0.17 m
C000	C000	0.26 m
B000	B000	0.35 m
A000	A000	0.47 m
9000	9000	0.6 m
8000	8000	0.8 m
7000	7000	1.0 m
6000	6000	1.2 m
5000	5000	1.5 m
4000	4000	2 m
3000	3000	3 m
2000	2000	5 m
1000	1000	Inf

\* VISCA Parameters and CGI Values use hexadecimal digits.

## ZOOM MAGNIFICATION (SRG-A40)

VISCA Parameter*	CGI Value*	Focus distance (for reference)
0000	0000	×1
0DC1	0DC1	×2
186C	186C	×3
2015	2015	×4
2594	2594	×5
29B7	29B7	×6
2CFB	2CFB	×7
2FB0	2FB0	×8
320C	320C	×9
342D	342D	×10
3608	3608	×11
37AA	37AA	×12
391C	391C	×13
3A66	3A66	×14
3B90	3B90	×15
3C9C	3C9C	×16
3D91	3D91	×17
3E72	3E72	×18
3F40	3F40	×19
4000	4000	×20
5556	5556	×30 (When Clear Image Zoom is used)
6000	6000	×40 (When Clear Image Zoom is used)
6AAB	6AAB	×60 (When the digital zoom is used)
7000	7000	×80 (When the digital zoom is used)
7334	7334	×100 (When the digital zoom is used)
7556	7556	×120 (When the digital zoom is used)
76DC	76DC	×140 (When the digital zoom is used)
7800	7800	×160 (When the digital zoom is used)
78E4	78E4	×180 (When the digital zoom is used)
799A	799A	×200 (When the digital zoom is used)
7A2F	7A2F	×220 (When the digital zoom is used)
7AC0	7AC0	×240 (When the digital zoom is used)

\* VISCA Parameters and CGI Values use hexadecimal digits.

## ZOOM MAGNIFICATION (SRG-A12)

VISCA Parameter*	CGI Value*	Focus distance (for reference)
0000	0000	×1
0FB4	0FB4	×2
1BF0	1BF0	×3
24C5	24C5	×4
2B1E	2B1E	×5
2FE4	2FE4	×6
33A9	33A9	×7
36C9	36C9	×8
3983	3983	×9
3BF7	3BF7	×10
3E1C	3E1C	×11
4000	4000	×12

\* VISCA Parameters and CGI Values use hexadecimal digits.

## VIDEO OUTPUT FORMAT

VISCA Parameter*	CGI Value	Video output format
00	720p_5994_VGA	1280x720/59.94p (HDMI:640x480/59.94p)
01	720p_5994	1280x720/59.94p
02	1080p_2997	1920x1080/29.97p
03	1080i_5994	1920x1080/59.94i
04	1080p_5994_ModeA	1920x1080/59.94p (Level A)
05	1080p_5994_ModeB	1920x1080/59.94p (Level B)
06	2160p_2997	3840x2160/29.97p
11	720p_50	1280x720/50p
12	1080p_25	1920x1080/25p
13	1080i_50	1920x1080/50i
14	1080p_50_ModeA	1920x1080/50p (Level A)
15	1080p_50_ModeB	1920x1080/50p (Level B)
16	2160p_25	3840x2160/25p
21	1080p_2398	1920x1080/23.98p
22	2160p_2398	3840x2160/23.98p

\* VISCA Parameters use hexadecimal digits.

## LENS CONTROL

Zoom Position* <sup>1</sup>	0000 - 4000 - 7AC0 Wide end    Optical    Digital Tele end    Tele end	
Focus Position	1000 - F000 Far end    Near end	
Focus Near Limit	1000: Inf	Use the distance shown as a guide value as it may vary depending on the temperature characteristics. * The lower 1 byte is fixed at 00.
	2000: 5 m	
	3000: 3 m	
	4000: 2 m	
	5000: 1.5 m	
	6000: 1.2 m	
	7000: 1.0 m	
	8000: 0.8 m	
	9000: 0.6 m	
	A000: 47 cm	
	B000: 35 cm (initial value)	
	C000: 26 cm	
D000: 17 cm		
E000: 10 cm		
F000: 8 cm		

\*<sup>1</sup> The range for SRG-A12 is 0000-4000.

## PAN-TILT STATUS CODE

<b>p</b>	<b>p</b>	<b>p</b>	<b>p</b>	<b>Status</b>
- - - -	- - - -	- - - -	- - - 1	Panning reaches the end of the left.
- - - -	- - - -	- - - -	- - 1 -	Panning reaches the end of the right.
- - - -	- - - -	- - - -	- 1 - -	Tilting reaches the upper limit.
- - - -	- - - -	- - - -	1 - - -	Tilting reaches the lower limit.
- - - -	- - - -	- - 0 0	- - - -	Pan functions normally.
- - - -	- - - -	- - - 1	- - - -	Pan position cannot be detected.
- - - -	- - - -	- - 1 -	- - - -	Pan mechanism is defective.
- - - -	- - 0 0	- - - -	- - - -	Tilt functions normally.
- - - -	- - - 1	- - - -	- - - -	Tilt position cannot be detected.
- - - -	- - 1 -	- - - -	- - - -	Tilt mechanism is defective.
- - - -	0 0 - -	- - - -	- - - -	No movement instruction
- - - -	0 1 - -	- - - -	- - - -	Pan/Tilt operating
- - - -	1 0 - -	- - - -	- - - -	Pan/Tilt operations complete.
- - - -	1 1 - -	- - - -	- - - -	Pan/Tilt operations failed.
- - 0 0	- - - -	- - - -	- - - -	Not initialized
- - 0 1	- - - -	- - - -	- - - -	Initializing
- - 1 0	- - - -	- - - -	- - - -	Initialization completes.
- - 1 1	- - - -	- - - -	- - - -	Initialization failed.

( - : optional)

## TIME ZONE

No.	CGI	Time Zone
1	utc+1400	UTC +14:00
2	utc+1330	UTC +13:30
3	utc+1300	UTC +13:00 Nukualofa
4	utc+1230	UTC +12:30
5	utc+1200	UTC +12:00 Wellington
6	utc+1130	UTC +11:30
7	utc+1100	UTC +11:00 Solomon
8	utc+1030	UTC +10:30 Lord Howe
9	utc+1000	UTC +10:00 Sydney
10	utc+0930	UTC +09:30 Adelaide
11	utc+0900	UTC +09:00 Tokyo
12	utc+0830	UTC +08:30
13	utc+0800	UTC +08:00 Beijing
14	utc+0730	UTC +07:30
15	utc+0700	UTC +07:00 Bangkok
16	utc+0630	UTC +06:30 Yangon
17	utc+0600	UTC +06:00 Dhaka
18	utc+0530	UTC +05:30 Mumbai
19	utc+0500	UTC +05:00 Islamabad
20	utc+0430	UTC +04:30 Kabul
21	utc+0400	UTC +04:00 Abu Dhabi
22	utc+0330	UTC +03:30 Tehran
23	utc+0300	UTC +03:00 Moscow
24	utc+0230	UTC +02:30
25	utc+0200	UTC +02:00 E-Europe
26	utc+0130	UTC +01:30
27	utc+0100	UTC +01:00 C-Europe
28	utc+0030	UTC +00:30
29	utc+0000	UTC Greenwich
30	utc-0030	UTC -00:30
31	utc-0100	UTC -01:00 Azores
32	utc-0130	UTC -01:30
33	utc-0200	UTC -02:00 M-Atlantic
34	utc-0230	UTC -02:30
35	utc-0300	UTC -03:00 Sao Paulo
36	utc-0330	UTC -03:30
37	utc-0400	UTC -04:00 Halifax
38	utc-0430	UTC -04:30
39	utc-0500	UTC -05:00 New York
40	utc-0530	UTC -05:30
41	utc-0600	UTC -06:00 Chicago
42	utc-0630	UTC -06:30
43	utc-0700	UTC -07:00 Denver
44	utc-0730	UTC -07:30
45	utc-0800	UTC -08:00 LA
46	utc-0830	UTC -08:30
47	utc-0900	UTC -09:00 Anchorage

No.	CGI	Time Zone
48	utc-0930	UTC -09:30
49	utc-1000	UTC -10:00 Honolulu
50	utc-1030	UTC -10:30
51	utc-1100	UTC -11:00 M-Island
52	utc-1130	UTC -11:30
53	utc-1200	UTC -12:00