



Slim NanoSaver® 2.0 Dual Headed Lock

Part Number: K65023WW | UPC Code: 0 85896 65023 2

Two locks, one key.

The latest laptops from HP, Lenovo, and Asus increasingly feature the Kensington Nano Security Slot, offering all the security and benefits of the standard Kensington Security Slot™, yet 70% smaller.

However, these ultra-thin devices may be so slim that while a standard cable lock will fit, the thickness of the lock can be greater than the laptop itself. This prevents the device from lying flat on a surface, making the keyboard and trackpad uncomfortable to use.

With connectivity ports placed closer and closer together, a standard lock can also block adjacent ports, compromising functionality.

A re-designed version of the innovative Slim NanoSaver® Laptop Lock, the Slim NanoSaver® 2.0 Dual Headed Lock features a smaller lock head, with the locking cleat positioned low, and the key cylinder up high and out of the way. This careful sizing and positioning of components has created a premium locking solution that won't block ports and allows ultra-thin and 2-in-1 laptops with nano lock slots to lie flat and stable.

A secondary lock secures peripheral accessories such as a monitor, hard drive, printer, or docking station — all in one solution.

Strength tested and verified for industry-leading standards in torque/pull, foreign implements, lock lifecycle, corrosion, and other environmental conditions, the lock is backed by a five-year limited warranty, so you can rest assured knowing you're covered by Kensington, inventor and a worldwide leader in laptop security locks.

Features include:

- Locks two devices with a single solution
- Slim profile won't block ports and allows laptop to lie flat and stable
- Cut-resistant carbon steel cable
- Verified and tested
- 5mm keying system
- Register & Retrieve™
- Five-year limited warranty

Slim NanoSaver® 2.0 Dual Headed Lock

Part Number: K65023WW | UPC Code: 0 85896 65023 2

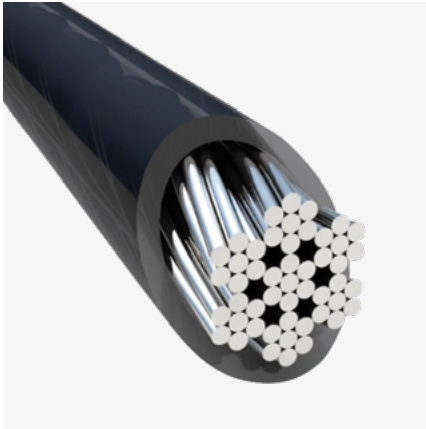

Dual Lockheads with Carbon Steel Cable

A NanoSaver® primary lock secures laptops and other devices with Kensington's NanoSaver slot. A MicroSaver® 2.0 secondary lock secures peripheral accessories featuring the standard size Kensington security slot. Cut-resistant carbon steel cable includes a protective sheathing to help keep attachment points such as desks and tables free from scratches.



Won't Block Ports, Allows Ultra-Thin & 2-in-1 Laptops to Lie Flat and Stable

Slim nano lock head design won't interfere with I/O ports or raise the device off its surface.



Verified and Tested

Each Kensington lock is precision engineered to meet or exceed rigorous industry standards for strength, physical endurance, and mechanical resilience.



5mm Keying System

Common across all of Kensington's latest locks, so there's only one keying system to manage. Smaller key opening helps thwart picking attempts.



Register & Retrieve™

Register & Retrieve™

Kensington's online key registration program that allows for quick, secure, and free key replacement if ever lost or stolen.



Five-Year Limited Warranty

Rest assured knowing you're covered by Kensington, inventor and a worldwide leader in laptop security locks.

Strength Features – Standard Cable Locks

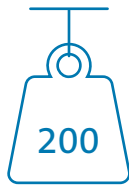

Locks designed and tested to withstand a minimum straight pull force of 200lb.



Locks designed and tested to withstand a minimum side pull force of 400lb.

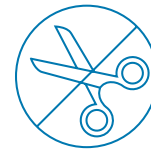

Carbon steel cable resists minimum cutting forces of 1,000 lbf. Sheathing cover offers security, and greater mobility while protecting surfaces from scratches.



Cable rotation, lock attachment, and lock tip rotation tested to 8,000 cycles.



Lock heads designed and tested to withstand extreme temperatures ranging from -22° to 149° Fahrenheit (-30° to 65° Celsius)



Lock body tested for materials structural integrity. (Drop damage, hard impact, vibrations, and corrosion)



Slim NanoSaver® 2.0 Dual Headed Lock

Part Number: K65023WW | UPC Code: 0 85896 65023 2

Material Specifications

| | |
|---------------|----------------------------------|
| Lock Head | Zinc Die Cast |
| Keys | Zinc Die Cast + Plastic Cover |
| Cable Lock | Carbon Steel with Plastic Sheath |
| Product Color | Silver |

Product Dimensions

| | |
|----------------------|---|
| Lock Head Dimensions | Slim NanoSaver Keyed Lock only: 0.44 x 0.80 x 1.56in (11.1 x 20.26 x 39.55mm) |
| Cable Dimensions | Standard Cable: Diameter 0.20in (5.0mm) |
| Unit Weight | 8.3oz (236g) |

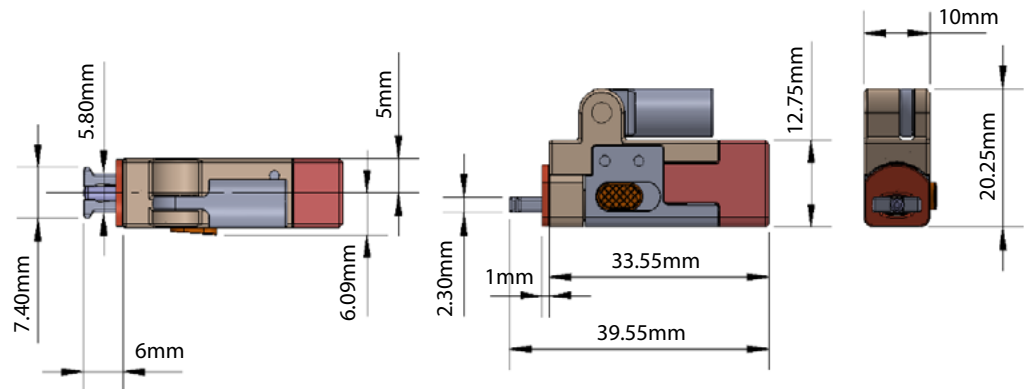

Packaging Dimensions

| | |
|----------------------|--|
| Packaging Style | Polybag |
| Packaging Dimensions | 0.83 x 7.87 x 13.39in (21 x 200 x 340mm) |
| Packaging Weight | 9.1oz (258g) |
| Packaging Content | 1x Slim NanoSaver Keyed Lock + 1x MS2.0 Lock in Dual/Twin Cable Configuration 2x User Keys 1x Instruction Guide 1x Warranty Card |
| Master Carton | 25 units |

Country of Origin, Regulatory, and Warranty

| | |
|-----------------------------|------------------------------------|
| Country of Origin | China |
| Certifications & Compliance | RSL compliant. CA Prop65 compliant |
| Warranty | 5-Years |

Slim NanoSaver® 2.0 Dual Headed Lock

Part Number: K65023WW | UPC Code: 0 85896 65023 2

Multiple SKUs

Slim NanoSaver® 2.0 Dual Headed Lock

K65023WW

K65024M - Master Keyed

K65024L - Like Keyed

K65024S - Supervisor Keyed



All specifications are subject to change without notice. Products may not be available in all markets. Kensington and the ACCO name and design are registered trademarks of ACCO Brands. Kensington The Professionals' Choice is a trademark of ACCO Brands. All other registered and unregistered trademarks are the property of their respective owners. © 2022 Kensington Computer Products Group, a division of ACCO Brands. All rights reserved. k22-21018p

FOR MORE INFORMATION CONTACT: 1-855-692-0054 | sales@kensington.com

Kensington

The Professionals' Choice™